



Diamond Shamrock

June 10, 1983

Michael Catania
Office of Regulatory Services
Department of Environmental Protection CN402
John Fitch Plaza
Labor and Industry Building - 8th Floor
Trenton, New Jersey 08625

Re: Former Diamond Shamrock Premises
80 Lister Avenue, Newark, New Jersey

Dear Mr. Catania:

Enclosed is the information Diamond Shamrock Corporation agreed on June 3 to provide on the Lister Avenue facility. On June 6, we provided the legal and technical contacts you requested. On June 7 we sent the list of employees and a NIOSH report on the facility derived from information we had previously submitted to NIOSH.

We have prepared an overview of the history and operations at the site. Our submittal represents our best effort in the time available to us and represents a reconstruction of the operations to the best of our knowledge. The corrections to the NIOSH report were deferred in order to answer the issues raised in Mr. Hughey's letter. We will provide further information on the NIOSH report as soon as practical. As indicated we ceased production in August 1969 and sold the property in March 1971. We are not knowledgeable as to changes that have occurred on site since we sold the property.

After your review of this information, we are ready to meet at your earliest convenience to discuss site remediations. We wish to express again our commitment to work with the State of New Jersey on the expeditious and proper containment of the site.

Very truly yours,

James B. Worthington

James B. Worthington
Director, Environmental Affairs

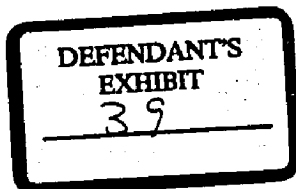

/lkx

RECEIVED
JUN 14 1983
U.S. DEPARTMENT OF JUSTICE
ENVIRONMENTAL PROTECTION AGENCY

REPORT ON LISTER AVENUE FACILITY

JUNE 10, 1983

PLANT LOCATION AND HISTORY

Diamond Alkali purchased from Kolker Chemical a 1.8 acre tract of land located at 80 Lister Avenue, Newark, New Jersey in March of 1951. The plant (as shown in Table 1) was operated as an agricultural chemicals manufacturing facility by Diamond Shamrock until August 1969 when the plant was shut down. Records reflect that all of the manufacturing took place on the 1.8 acre site. In January of 1956, an easement was acquired for the construction of a 10" sewer line under the railroad tracks on the east side of the property. Additional 1.6 acres of property were leased from Triplex Oil and Refining Company (subsequently Walter Ray Holding Company and eventually William Leckie) in April 1960 and this property accommodated storage facilities and warehouses (outlined by dashed areas in Figure 1). The only other major property associated with the plant appeared to be a parking lot leased in 1963 from Sergeant Chemical Company (Figure 2, dashed line, Site D.A.C.O. L2).

In March 1971, the 1.8 acre site was sold and the 1.6 acre site lease was assigned to Chemicaland Corporation. Principals of Chemicaland were George W. Mitchell and Raymond A. Guidi (a former plant manager of the facility). It appears the plant was involved in the production of benzoic acid, with a small amount of 2,4-D being manufactured for Diamond Shamrock for a limited time. In 1980, the 1.8 acre site was purchased in a tax sale by Mr. William Leckie (Ray Holding Company) and was subsequently sold to Marisol Company in early 1981.

GENERAL PROCESS DESCRIPTION

The production of 2,4,5-trichlorophenoxyacetic acid esters involves several process steps. The initial step is the production of sodium trichlorophenate followed by reaction with sodium monochloroacetate to yield the sodium salt of trichlorophenoxyacetic acid. This salt was, in turn, reacted with sulfuric acid to yield the 2,4,5-trichlorophenoxyacetic acid (2,4,5-T) with a suitable alcohol at the proper reaction conditions to give the corresponding ester or with a suitable amine to give the corresponding amine salt.

CONFIDENTIAL

Page Two

Over the period 1951-1969 when the Newark facility was operated, the process was altered several times to improve operability and to increase capacity. These changes and the dates made are outlined in Table 2. The total 2,4,5-T production capacity of the Lister Avenue facility accounted for less than 10% of the total U. S. manufacturing capacity in 1969.

Production capacity changes are summarized in Table 3.

PROCESS LOCATION - SITE PLAN AND WASTES GENERATED

Dioxin formation has been identified as inherent in the process for manufacturing sodium 2,4,5-trichlorophenate by the caustic hydrolysis of 1,2,4,5-tetrachlorobenzene. Consequently, the following discussion relates specifically to this process. The primary chemical reaction in this process is shown in Figure 3.

Period 1951 - 1960

Manufacture of starting and intermediate chemicals was conducted in a five story, 50 year old building which occupied 29,000 square feet of a 1.8 acre plant site. The building was located adjacent to the Passaic River and is shown in outline form on Figure 4 dated February 14, 1959. This building also housed the offices, laboratory maintenance facilities and first aid dispensary for the plant.

The phenoxy acids, esters, amine salts and formulations thereof were prepared in a separate smaller building located to the east of the main manufacturing building.

All processing equipment for the manufacture of sodium 2,4,5-bichlorophenate (NaTCP) and other primary chemicals were located within the main building. Little information is available as to the exact location of the NaTCP equipment within the building because the records were destroyed in the explosion which occurred in 1960. A block flow diagram of the process used from 1951 to 1954 is included as Figure 5.

Wastes produced in this process included a filter cake which contained water insoluble materials, such as 1,2,4,5 tetrachlorobenzene (T_4CB), 2,4,5-trichloroanisole (TCA), and would likely trap any dioxin present in the reaction product. This process was replaced in 1954 (see Figure 6) with a steam distillation to remove T_4CB and TCA. Any dioxin present, because of its volatility, would also be removed either partially or totally. The distillate (organics) from this process step were stored for

CONFIDENTIAL

D

5036

MAXUS036797

Page Three

recycle in the future, subject to development of a process for their use. The first recycle of recovered organics from the steam distillation was made in December 1956 and was henceforth made a routine operation.

Liquid wastes from the process consisted of aqueous solutions of sodium chloride and sodium sulfate. Prior to October 1954, the aqueous solutions of sodium chloride and sodium sulfate were separate. After this date, the process was modified such that the sodium chloride and sodium sulfate were discharged as a single solution from the 2,4,5-T acid process.

Condensate (aqueous layer) from the steam distillation was the other liquid waste from the process.

Muriatic acid was also produced as a by-product in the main process building from the hydrogen chloride produced in the chlorination of acetic acid/anhydride to monochloroacetic acid and the chlorination of phenol to 2,4-dichlorophenol. This acid was produced in processes not related to the production of 2,4,5-trichlorophenol. The acid was generally sold to reclaimers.

Period 1961 - 1969

After the explosion in February 1960, the main process building was completely replaced with a new three story structure devoted exclusively to manufacture of NaTCP, 2,4-dichlorophenol (2,4-DCP), monochloroacetic acid (MCA) and by-product muriatic acid.

Two additional buildings separate from the process building were also provided. The largest of these housed the maintenance shop, production and shipping offices, and an area for materials storage. The smaller building housed the general plant offices, the quality control laboratory, and the dressing room. The site plan (Figure 7) shows the location of each of these new buildings.

Other improvements related to bulk materials storage were also made at this time.

The new process building was designed to have all drainage trenches discharge through a sump into the industrial sewer.

The plant was expanded in 1967 by the addition of a new 2,4-D acid unit and conversion of the old 2,4-D acid unit to 2,4,5-T acid manufacture. The warehouse was expanded and an extension added to the Process Building to house the NaTCP purification process. These changes are outlined on site plan (Figure 8).

CONFIDENTIAL

The basic process for preparation of NaTCP was not changed but provision was made for the removal of sodium chloride by filtration from the stream stripped solution of NaTCP and the removal of dioxin (2,3,7,8-TCDD) by adsorption on activated carbon (Figure 9). The sodium chloride recovered in the filter was dissolved in water for disposal by the industrial sewer.

The activated carbon in the adsorption column was treated with muriatic acid and hot water washes to remove iron hydroxide. These treatment solutions were then disposed of to the industrial sewer. Spent carbon was removed from the unit and handled by a disposal firm.

The basic processes for manufacturing the 2,4,5-T acid, esters or amine salts were not changed.

Production operations were terminated in August 1969.

OTHER MANUFACTURING ACTIVITIES

Several other products as listed in the following table were manufactured during the period 1951-1960, but were discontinued for economic reasons and not produced after the explosion in February 1960. It is believed that the records of these products were also in the explosion.

<u>Product</u>	<u>Chemical Name</u>
HCB	Hexachlorobenzene
DDT	dichlorodiphenyl trichloroethane Ovex, Multicide
K101	p-chlorophenyl-p-chlorobenzene sulfonate
Compound 923	2,5-dichlorophenyl-p-chlorobenzene sulfonate
Chloral	1,1,1-trichloroacetaldehyde
BSC	benzenesulfonyl chloride
BCBSC	p-chlorobenzene sulfonyl chloride
BCBSA	p-chlorobenzene sulfonamide
44-DDS	4,4-dichlorodiphenylsulfone
PAABSC	p-acetylamino benzene sulfonyl chloride
PMESC	p-methoxy benzenesulfonyl chloride

CONFIDENTIAL

ENVIRONMENTAL MANAGEMENT

Information about environmental activities at the Lister Avenue plant is limited, particularly in the pre-1960 period. The relationship of the levels of dioxin in the water, air, and solid waste by-products is based upon process evaluations and projections.

Information about wastewater practices indicate that in 1956, process wastewaters were discharged through a 10" industrial sewer to the Passaic Valley Sewerage Commission. In the fifties and sixties, there are indications of acid discharges to the Passaic River, but these releases were likely muriatic acid and sulfuric acid. The only acid discharges appeared to be amounts that were not sent to acid reclaimers. Both the muriatic acid and sulfuric acid should not have been contaminated with dioxins since they were not directly associated with the TCP processes. It is believed that the TCP acid waste streams were routed to a sump before the over-flow was discharged to the industrial sewer. Since the dioxins are relatively insoluble in water and adsorb readily to suspended particles, it is believed that the sump could have eliminated some of the waste before discharge to the sewer. The sump was in operation in 1965 and perhaps earlier. Process wastewaters including acid wastes were estimated to be 30,000 gallons per day in 1960, and approximately one-third could have contained some dioxins. Since the process areas were under a roof, storm run-off exposure to process wastes were limited. All run-off from tank storage areas after 1961 was discharged to the industrial sewer system.

Information on air emissions indicated that all vents were inside the process buildings until the late 1960's. Emissions of dioxins would likely be in the form of a particulate and not a gas. This likely reduced the level of emissions going off-site. A 20,000 SCFM, 7' diameter Peabody caustic scrubber was in operation in 1963. This scrubber emitted through a 20 foot high stack and cleaned the process vent emissions from the plant. In 1966, a construction permit was filed with the State for a plant modification. The application cited the controlled emissions to be:

	<u>lb/hr</u>	<u>ppm</u>
Sodium salt of 2,4-D	0.18	2
Sodium salt of DCP	0.12	1.4
Sodium salt of MCA	0.12	1.3
Sodium salt of 2,4,5-T	0.06	0.8
Sodium salt of TCP	0.06	0.8

CONFIDENTIAL

All process vent emissions were controlled by the scrubber from 1967 to the plant shut-down in 1969. In 1969, emissions were controlled by the scrubber to a level of 10 pounds per day of organic particulates.

Solid wastes generated at the site consisted of non-combustible process wastes, miscellaneous combustible and non-combustible containers and trash. All wastes were hauled off-site by a contractor, Mr. Nick Toscano.

The process wastes were filter cake from product filtration, spent carbon from the carbon column and sludge removed from the process area waste sump. In 1967, these wastes totaled eight (8) tons per year. In 1969, the wastes totaled three and a half (3.5) tons per year.

A carbon column was installed to remove dioxin from the TCP production in September 1967. The first column was a "pilot" unit 12" diameter. This unit was used from September 8, 1967, until the installation of a full-scale column in July of 1968 during the plant's annual shut-down. In January, 1969, the carbon in the "new" column was replaced. This carbon was in use when production of 2,4,5-T was discontinued in July, 1969.

The carbon bed was washed with acid when the dioxin level of the TCP could not be maintained at an acceptable level, or the column plugged. The dioxin was bonded firmly to the carbon. Although the spent acid was severed, it is unlikely that the dioxin desorbed from the carbon. The spent carbon was drummed and disposed of off-site by waste disposal contractor. This appeared to be done in January, 1969. After the process was shut down, the column was reportedly included in the sale to Chemicalund Corporation. The management of Chemicalund was informed of the contents of column.

The water-related upsets are limited to acid releases to the Passaic River largely during the fifties and early sixties. In 1964, an acid release was corrected by the relocation of a process over-flow. A citation in 1968 resulted from a sulfuric and hydrochloric acid discharge.

An explosion occurred in the trichlorophenol unit in February 1960. The vessel which ruptured was the 1,000 gallon reactor used to hydrolyze 1,2,4,5-tetrachlorobenzene to sodium 2,4,5-trichlorophenolate. Although the reason for the failure was unknown, it was postulated that a runaway reaction which produced a large volume of gaseous products was responsible for the failure. The dispersal of this material discharge was partially contained by the building structure and directed away from the adjacent property.

CONFIDENTIAL

Table 1
Ownership History

<u>Date</u>	<u>Event</u>
3/51	1.8 acres purchased from Kolker Chemical Works, Inc. by Diamond Alkali (as shown by Figure 2).
1/56	Acquisition of easement and construction of 10" clay sewer pipe in 36" reinforced concrete casing 355' East of Brown Street under tracks (See Figure 1).
4/60	DSC lease of 1.6 acres of adjacent property owned by Triplex Oil Company.
11/63	Lease of parking lot from Sergeant Chemical Company.
8/69	DSC production ceased.
3/70	Production of 2,4-D by former employee.
3/71	Sale of 1.8 acres tract and manufacturing facilities to Chemicaland Corporation; assignment of Triplex 1.6 acre lease to Chemicaland Corporation.
1980	Property purchased in tax sale by William Leckie (Ray Holding; formerly Triplex Oil Company).
1981	Property sold to Marisol Company.

CONFIDENTIAL

Table 2

Process and Plant Changes

<u>Date</u>	<u>Change</u>
Early 1951	Initiated production of 2,4,5-TCP and 1,2,4,5 tetrachlorobenzene in a 500 gallon reactor. Used a dilution process with filtration to remove water insoluble organics from reaction mix.
January 1952	Initiated the use of purchased 1,2,4,5 tetra-chlorobenzene because time was not available to make our own.
May 1952	Decision to increase capacity from 40,000 lb/mo to 120,000 lb/mo by installation of an additional 1,000 gallon reactor.
Feb/March 1953	Probable time for start-up of the new 1,000 gallon reactor.
September 1954	Steam stripping substituted for dilution process for the removal of organics on a routine basis.
December 1954	Do not remove salt (sodium chloride) from the NaTCP reaction mass but carry it through to the 2,4,5-T process and then separate all the salts at one time.
January 1955 to November 1956	No major process changes were made during this time frame.
December 1956	Initiated recycle of recovered organics.
January 1956 to February 1960	No major process changes during this period.
February 20, 1960	Explosion in NaTCP autoclave. Process building destroyed. Production of all materials ceased.
June 1960	Approval to reconstruct the plant. Reconstruction included complete replacement of the old process building.
February 1961	Rebuilt plant start-up. NaTCP now involved two 1,000 gallon reactors. Salt to be removed from NaTCP after steam stripper.
August 1967	2,4,5-T acid facility (old 2,4-D unit) was completed to produce a capacity of 3 MM lbs/yr of 2,4,5-T.

CONFIDENTIAL

0

50070

MAXUS036803

Page Two

September 1967	2,4,5-TCP purification facility completed for removal of p-dioxin (2,3,7,8-TCDD).
November 1967	New 2,4-D acid facility completed with a capacity of 12 MM lb/yr.
August 1969	All production terminated.

CONFIDENTIAL

Table 3
Production Capacity Changes

	<u>TCP</u>	<u>2,4,5-T Acid</u>
January 1951	- 0.5 MM lb/yr	- 0.65 MM lb/yr
February to March 1953	- 1.5 MM lb/yr	- 2.0 MM lb/yr
February 1961	- 1.9 MM lb/yr	- 2.5 MM lb/yr
November 1967	- 2.3 MM lb/yr	- 3.0 MM lb/yr

* Production by the capacity of the 2,4,5-T acid unit.

CONFIDENTIAL

COPIED

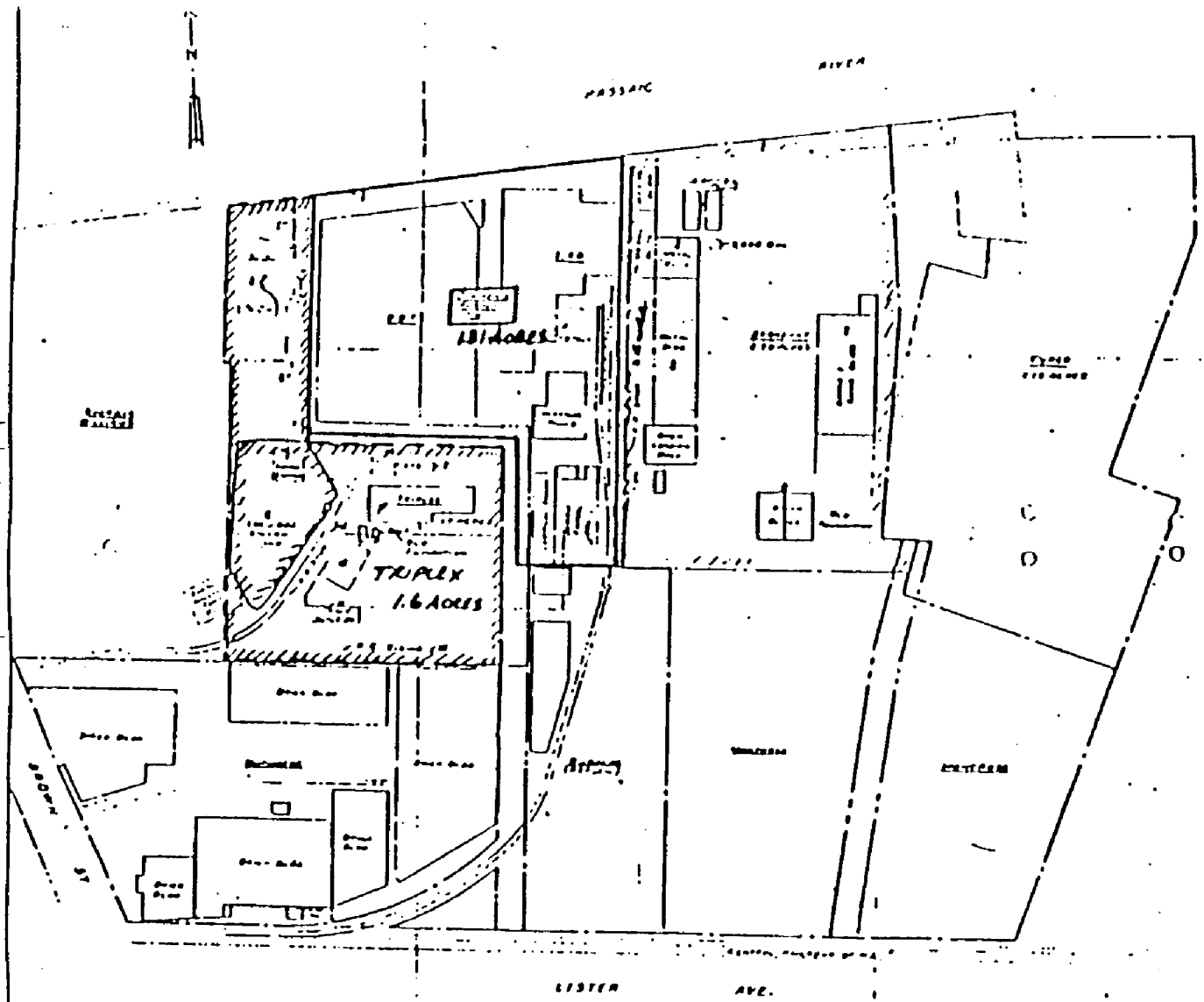

FIGURE

REVISION DESCRIPTION		REVISION DESCRIPTION		REVISION DESCRIPTION		REVISION DESCRIPTION	
1		1		1		1	
2		2		2		2	
3		3		3		3	
4		4		4		4	
5		5		5		5	
6		6		6		6	
7		7		7		7	
8		8		8		8	
9		9		9		9	
10		10		10		10	
11		11		11		11	
12		12		12		12	
13		13		13		13	
14		14		14		14	
15		15		15		15	
16		16		16		16	
17		17		17		17	
18		18		18		18	
19		19		19		19	
20		20		20		20	

NEWARK PLANNING
 PLAT OF NEIGHBORHOOD
 AND ADJACENT
 PROPERTIES

NF-98

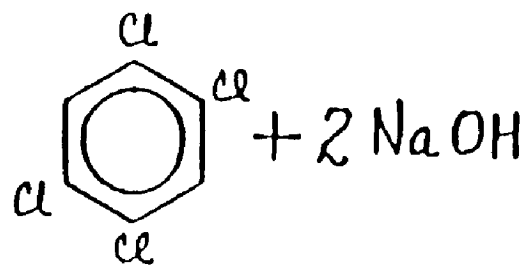

1,2,4,5-Tetrachlorobenzene
(T₄CB)

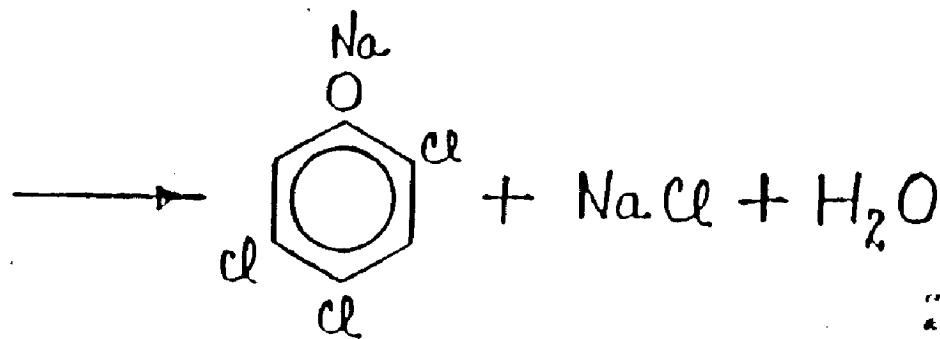

Sodium 2,4,5-trichlorophenolate
(NaTCP)



Diamond Shamrock
Gulf Coast Area
Environmental Control

PRIMARY CHEMICAL REACT

Dr. By	Date	Scale	Drawing No.
Appr. By	Date		1004-0000

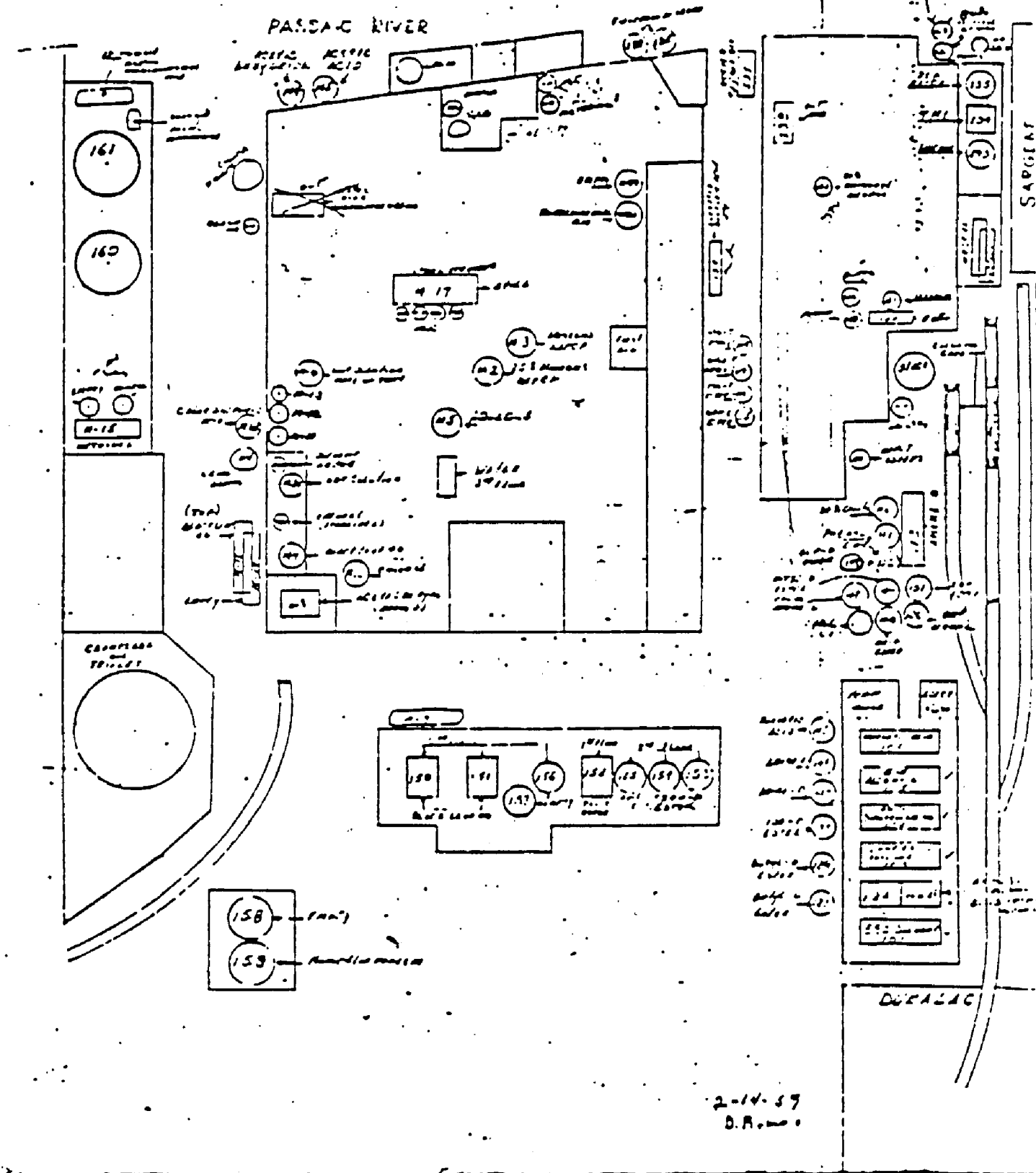

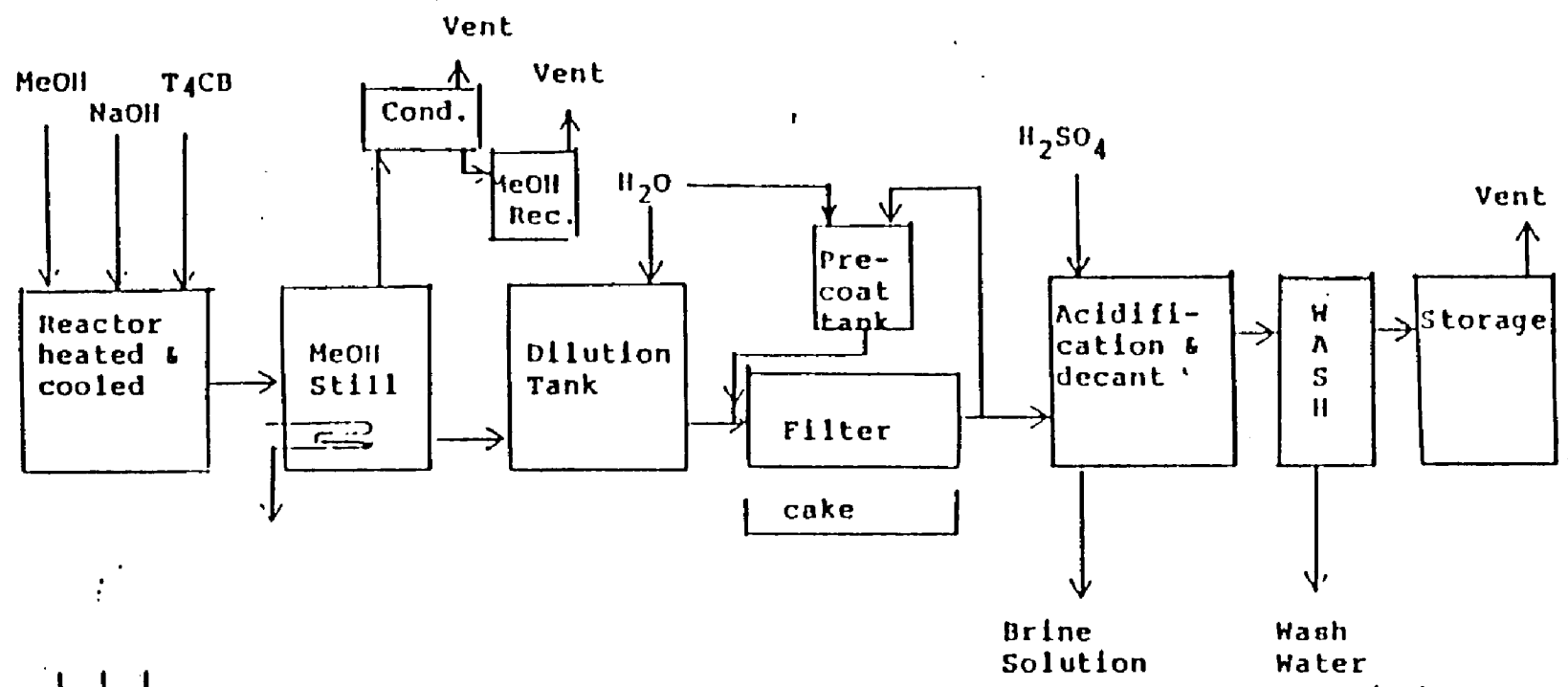

CONFIDENTIAL

FIGURE 4 OF 52070

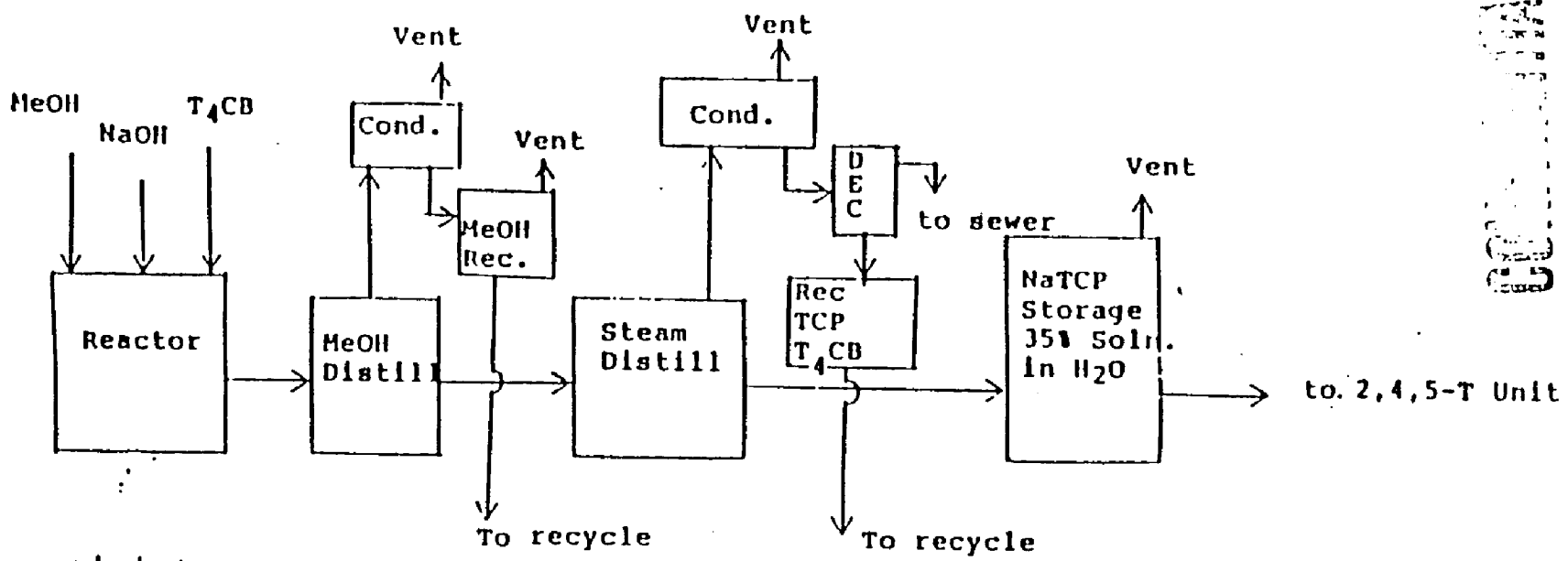

 Diamond Shamrock Environmental Control			
Na 2,4,5- TCP Flowsheet 1951 - 1954 Dilution Process			
Dr. By _____	Date 4/1/23	Scale	Drawing No. E1610 E
Appr. By _____	Date		



		Diamond Shamrock	
Environmental Control			
Na 2,4,5-TCP Flowsheet 1954 - 1960 Steam Distillation Process			
Dr. By	Date 4/1/63	Scale	Drawing No.
Appr. By	Date	FIGURE 6	

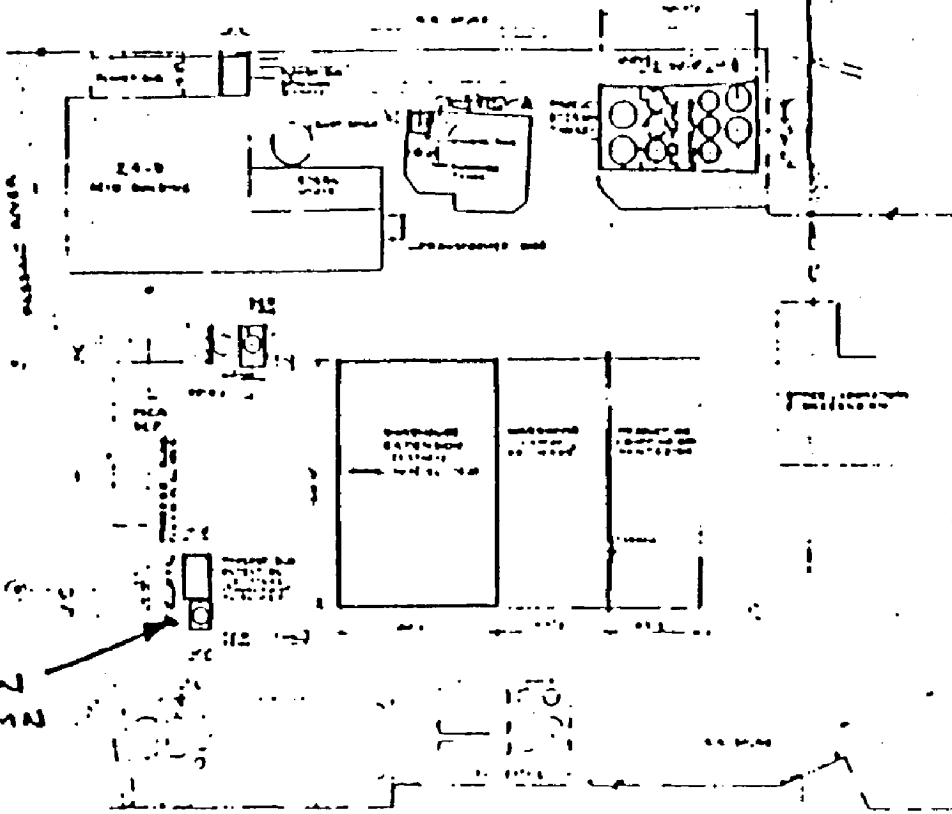
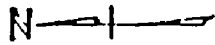



CARBON COLUMN

CONFIDENTIAL

FIGURE E

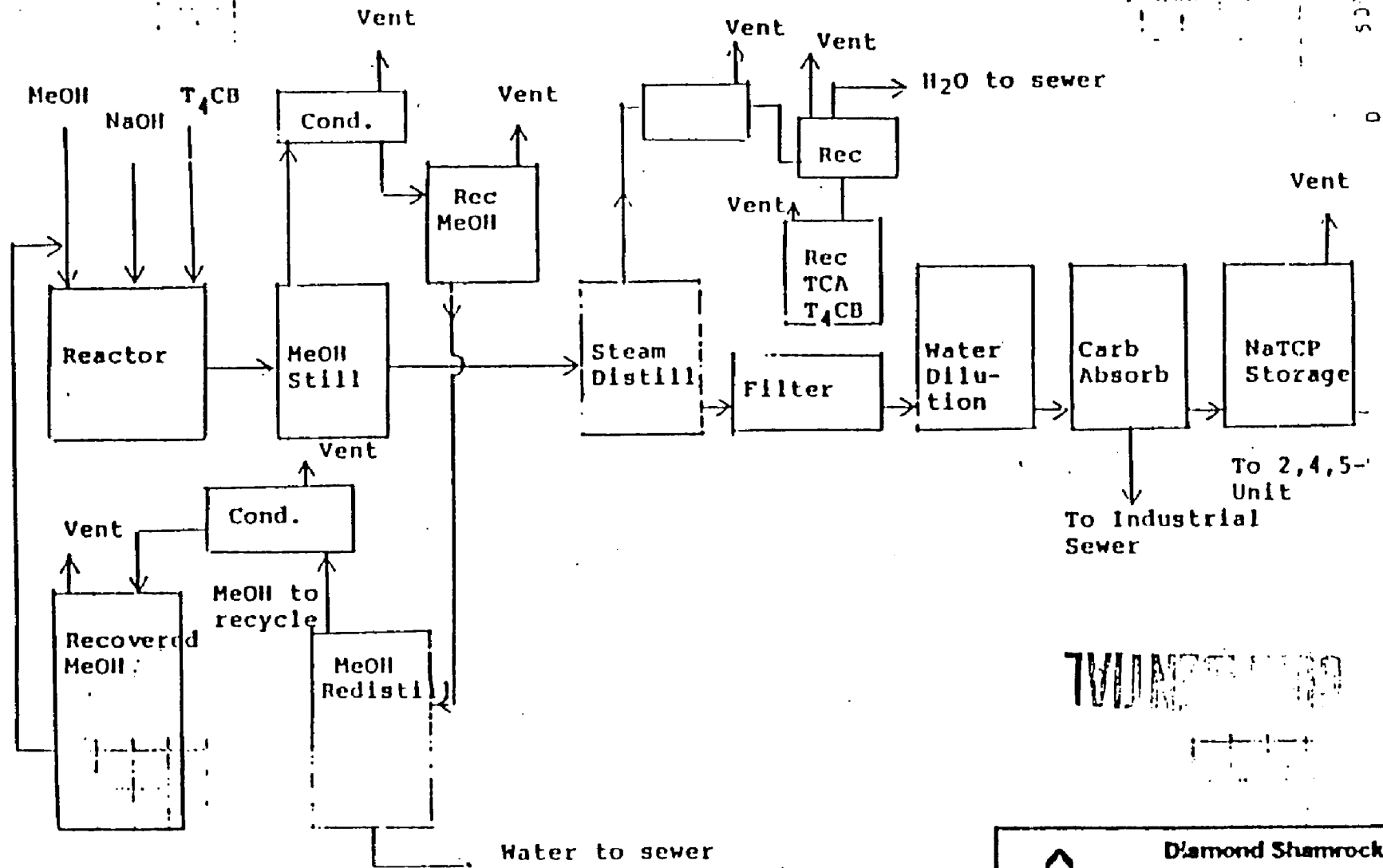
OPERATIONAL SECURITY	
CLASSIFICATION AND CONTROL	
PROHIBITION ON DISSEMINATION	
EXEMPTION FROM AUTOMATIC DOWNGRADING AND DECLASSIFICATION	
EXEMPTION CODE	EXEMPTION AUTHORITY
EXEMPTION DATE	EXEMPTION REVIEW DATE
DIAMOND ALUMINUM CO.	
EAST LANSING, MICHIGAN	
SITE PLAN	
2NS-581-4	



 Diamond Shamrock <small>Off Coast Area Environmental Control</small>			
Na 2,4,5- TCP Flowsheet 1960 - 1969 Steam Distillation Process			
Dr. By	Date	Scale	Drawing No
Appr. By	Date		FIGURE 1