

TRANSFER OF CREDIT ANNUAL REPORT TO GOVERNOR & LEGISLATURE

Introduction

There are numerous routes to obtaining a bachelor's degree. Students can begin their education at a community college, a state college or university, a private college or university, or a proprietary school. Students in the course of obtaining their degree may move from one institution to another. In 2007, there were 10,249 new transfers into senior public colleges and universities in New Jersey. That number has grown from 9,853 in 2003. The report focuses on the transfer of credit process for students who pursue their bachelor's degrees at a New Jersey senior public institution of higher education after having attended a New Jersey community college.

Assemblywoman Pamela Lampitt introduced legislation in the fall of 2006 to create a seamless transfer path for community college students. The duplication of courses was both a financial problem and a serious impediment to completing a baccalaureate degree. The bill was reviewed by the Assembly Higher Education Committee and the Senate Education Committee and received final passage in June 2007.

In September 2007, Governor Jon Corzine signed the legislation and the implementation process began. The statute, (N.J.S.A. 18A: 62-46), describes the establishment of the Comprehensive State-wide Transfer Agreement (attached), which simplifies the course-by-course review process of transfer student transcripts into a block acceptance of the associate's degree as creditable as the first two years of a baccalaureate degree program at a senior public institution of higher education in New Jersey. The agreement also outlines the general education program parameters. Each senior public institution is responsible for establishing an appeals process through which a transfer student can appeal a decision regarding transfer of credit. The New Jersey Commission on Higher Education (the Commission) is required to prepare an annual report to the Governor and Legislature containing a compilation of the data it collected about community college students who transferred to senior public institutions of higher education in New Jersey.

At its July 25, 2008 meeting, the Commission adopted a resolution approving the form and content of the 2008 Transfer Report. In anticipation of the adoption, a draft data dictionary was distributed to the senior public institutions on July 3, 2008 in an effort to allow them as much time as possible to prepare for the data collection. November 3, 2008 was set as the deadline for the submission of data to the Commission. The deadline in statute for the report to the Governor and Legislature is November 15 each year.

Several institutions needed additional time to complete their submissions, because this was the initial year for both the data collection and submission. Given that the Commission needed the complete files to conduct its analyses, the Executive Director sought and was granted an extension of the deadline to December 31, 2008 by the Chair of the Senate Education Committee, Senator Shirley Turner, and the Chair of the Assembly Higher Education Committee, Assemblyman Patrick Diegnan. In addition, the legislators agreed to pursue an amendment to permanently change the deadline to December 31.

Report Format

Looking at the data collected, Commission staff has compiled the following information regarding the transfer process at each senior public institution:

- a brief summary of the institution's history, location, and current student body;
- two charts for each school displaying the information about Fall 2008 transfer students; and
- a description of the appeals process for students to seek redress for disputes about the transferability of certain credits based on the accepting institution's review of the student's transcript.

The transfer information for each college and university is displayed in charts and graphs (NJCC means New Jersey Community College). For two of the colleges, no transfer file was received. Copies of the letters received from those institutions regarding their rationale for not participating are included.

This report reflects enrollment data up to 2007. The enrollment data for 2008 is still preliminary and will not be final until May 2009. The source of the information is the SURE (Student Unit Record Enrollment) files for each of the institutions, the new transfer file, degree program inventory, and IPEDS (Integrated Postsecondary Education Data System) files. A description of the appeals process for each institution was requested through the New Jersey Presidents' Council. The descriptions of the appeals processes the Commission received from the senior public colleges and universities are also included.

The Commission presented the format to the officers of the New Jersey Presidents' Council as outlined in the Comprehensive State-wide Transfer Agreement, and shared the submitted data with each of the senior public colleges and universities.

Kean University

Founded in 1855, Kean University (formerly Newark State College) began as a normal school for training teachers and principals for the City of Newark. In 1957, it relocated to the Township of Union, its present site. In 1958, the institution's mission expanded from its original, single purpose to become a comprehensive undergraduate institution. Sixteen years later its name changed to Kean College of New Jersey. It was granted university status in 1997.

Kean offers 58 bachelor's degree programs.

Undergraduate enrollment in fall 2007 was 10,441 students: 7,976 full-time and 2,465 part-time.

The racial composition of the undergraduate population in fall 2007 was 47.9% White; 19.6% Black; 19.5% Hispanic; 5.9% Asian; 0.2% American Indian; 2.0% Alien; and 4.8% Unknown.

The table below shows five years of undergraduate fall enrollment.

Year	2003	2004	2005	2006	2007	2008
Undergraduate Total	10,179	9,947	10,035	9,990	10,441	n/a

The table below shows six years of new undergraduate transfer fall enrollment.

Year	2003	2004	2005	2006	2007	2008
Transfer Total	1,178	1,071	992	1,256	1,278	1,497

New Undergraduate Transfers Received by Kean University in Fall 2008

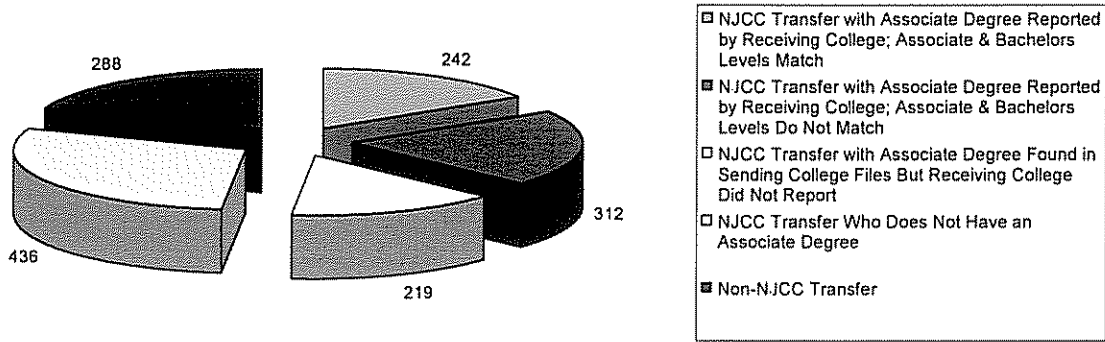

New Undergraduate Transfers from NJ Community Colleges to Kean University, Fall 2008

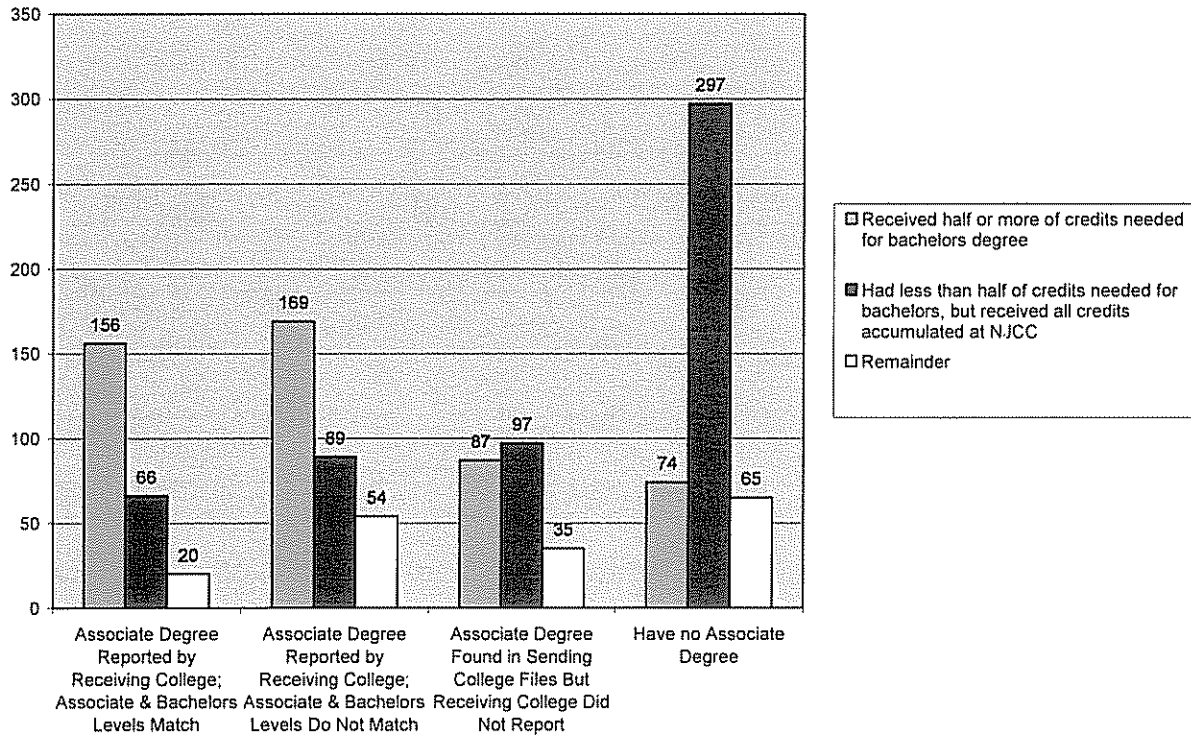

Kean University Internal Appeals Process for New Jersey Statewide Transfer Agreement

Listed below are the process of appeals to be taken to resolve issues regarding transfer of credits covered by the Statewide Transfer Agreement. This is in effect for students enter Kean for the first time beginning with the Fall 2008 semester, for students coming directly from a New Jersey County College (two-year institution). The Level 1 appeal must be made within 30 days of receiving the evaluation. The Level 2 appeal must be made within two weeks after the Level 1 decision. The Level 3 appeal must be submitted within two weeks after the Level 2 decision. The Level 4 appeal must be submitted within two weeks of the Level 3 decision. The Level 4 decision is final and will be made within three weeks after the receipt of the request. All decisions at Level 4 are final, and written notification of this outcome is sent to the student and the sending two-year institution.

Level 1 appeal: Submit an email appeal request, documenting the issue and asking to make an appointment to meet with the transfer evaluator who performed the initial evaluation. Below is a listing of the evaluators and the majors for which they perform the credit evaluations:

Kean Ocean Program (all majors and options at the undergraduate level)

Evaluator: Richard Harrell, Room 010, OCC Library building, 732-255-0400 extension 2042, harrellr@kean.edu

Students majoring in: Art History, Fine Arts (all options), Criminal Justice, Design (all options including Graphic Communication, Industrial Design, Interior Design, Visual Communication) Media and Film (all options), Music (all options), Social Work, Sociology (all options) Speech and Theatre and Theatre (all options).

Evaluator: Deborah Skibitsky, CAS 215, 908-737-0358 ds kibits@kean.edu

Students majoring in: Communication Studies (all options), English (all options), □History (all options) Philosophy/Religion, Political Science (all options), Psychology (all options), Psychiatric Rehabilitation, Spanish (all options).

Evaluator: Robyn Roebuck, CAS 216, 908-737-035, rroebuck@kean.edu

Students majoring in: Accounting, □Economics, (all options), Finance, Management (all options), Marketing, □Public Administration.

Evaluator: Andrea Rosa, CAS 217, 908-737-0357, arosa@kean.edu

Students majoring in: Athletic Training, Early Childhood Education, Elementary Education (K-5, K-5&5-8, Bilingual K-5, Bilingual K-5&5-8) Physical Education (all options) Recreation Administration (all options) Speech Language Hearing Science, Special Education (P-3, K-5, K-5&5-8).

Evaluator: Wilma Velazquez, CAS 219, 908-737-0355, velazquw@kean.edu

Students majoring in: Biology (all options), □Chemistry (all options), Computer Science (all options), Earth Science (all options), □Health Information Management (all options), Mathematical Sciences (all options), Medical Technology (all options), □Nursing (RN-BSN), Telecommunication/Information Technology.

Evaluator: Magalie Remy, CAS 218, 908-737-0354, mremy@kean.edu

Level 2 Appeal: If satisfactory resolution is not obtained at Level 1, the next level of appeal is made to Dr. Stephen Kubow, Director of the Center for Academic Success. Level one must be completed before Level 2 is initiated. Please submit an email appeal documenting the issue and requesting an appointment to begin the process. After meeting with the student and reviewing issue, the transcripts and the evaluation, the student will be notified in writing of the outcome of the appeal. The contact information to begin the process is:

Dr. Stephen Kubow, CAS 124, 908-737-0309, skubow@kean.edu

Level 3 Appeal: If satisfactory resolution is not obtained at Level 2, the student or county college may request a Level 3 appeal in writing. The request must include a detailed explanation of the request, and why the student or institution feels satisfactory resolution was not obtained at Level 2. This should be submitted to Dr. Stephen Kubow, Director, Center for Academic Success, Kean University, 1000 Morris Avenue, Union, NJ 07083 or electronically to skubow@kean.edu. Upon receipt, the Director will contact the Transfer Coordinator or other appropriate personnel at the sending two-year institution to attempt to work out a resolution to the issue. The student and two-year institution will be notified in writing of the decision on the appeal.

Level 4 Appeal: If satisfactory resolution is not obtained at Level 3, the student or institution may request a Level 4 appeal in writing. The request should include a detailed explanation of the issue and why the resolution at Level 3 was not satisfactory. The written request must be sent to the Office of the Vice President of Academic Affairs, Kean Hall, Kean University, 1000 Morris Avenue, Union, NJ 07083. The decision at this level is final. Written notification of the decision will be sent to the student and the sending two-year institution.

Montclair State University

Founded in 1908, Montclair State University (formerly Montclair State College) was the first teachers' college accredited by the Middle States Association as a liberal arts institution. It is located in Montclair in Essex County.

Montclair offers 56 bachelor's degree programs.

Undergraduate enrollment in fall 2007 was 13,017 students: 10,880 full-time and 2,137 part-time.

The racial composition of the undergraduate population in fall 2007 was 55.1% White; 9.7% Black; 19.3% Hispanic; 5.9% Asian; 0.2% American Indian; 4.7% Alien; and 5.0% Unknown.

The table below shows five years of undergraduate fall enrollment.

<u>Year</u>	<u>2003</u>	<u>2004</u>	<u>2005</u>	<u>2006</u>	<u>2007</u>	<u>2008</u>
Undergraduate Total	11,375	11,819	12,174	12,365	13,017	n/a

The table below shows six years of new undergraduate transfer fall enrollment.

<u>Year</u>	<u>2003</u>	<u>2004</u>	<u>2005</u>	<u>2006</u>	<u>2007</u>	<u>2008</u>
Transfer Total	1,234	1,182	1,112	1,195	1,298	1,360

New Undergraduate Transfers Received by Montclair State University in Fall 2008

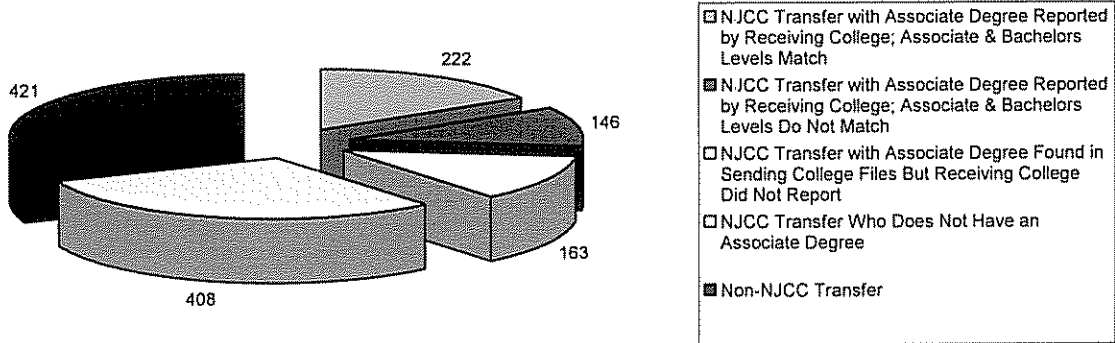

New Undergraduate Transfers from NJ Community Colleges to Montclair State University, Fall 2008

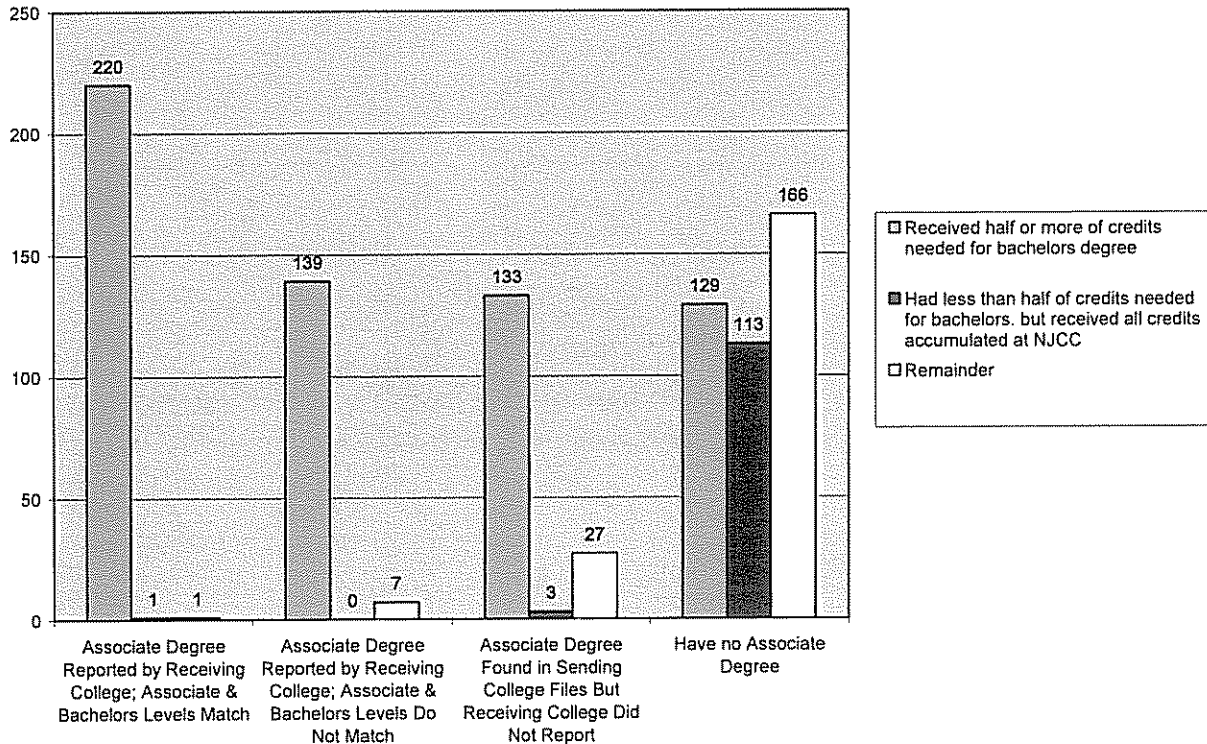

NJ Statewide Transfer Agreement Appeals Process

This process addresses students' concerns that a misinterpretation of the stated policies in the *NJ Statewide Transfer Agreement* has occurred. Appeals will be considered within thirty days of completion of the student's transfer credit evaluation.

(This document and accompanying appeals process are not intended to initiate a request for course substitutions. Students wishing to make such a request should file a "Course Substitution Request.")

Appeals procedure:

- Appeals must include both the reason for appeal and all supporting documentation to verify course credit and placement.
- All appeals must be submitted electronically to the Director of the Center for Academic Advising and Adult Learning (CAAAL) at the following email address njtransferappeals@mail.montclair.edu
- Completed documents will be reviewed by Montclair State University's NJ Statewide Transfer Agreement Appeals Committee. The Appeals Committee will respond to the student's petition within fourteen business days *of receipt of appeal letter; the appeal letter must include the actual date it is filed with the University*. All decisions will be communicated to the student via the student's Montclair State University email address; this will require the students to establish a NetID prior to submitting this form.

DATE: _____

Name: _____

MSU ID: _____

Name of community college attended _____

Statement of appeal (and accompanying documentation as required):

NJ Statewide Transfer Agreement Appeals Process
Page Two

Name: _____

MSU ID: _____

New Jersey Institute of Technology (NJIT)

Founded in 1881 as the Newark Technical School, the New Jersey Institute of Technology has grown into a technological research university with schools of engineering, architecture, science and liberal arts, management, and computing sciences, as well as an honors college. Its campus is located in Newark in Essex County.

NJIT offers 44 bachelor's degree programs.

Undergraduate enrollment in fall 2007 was 5,428 students: 4,353 full-time and 1,075 part-time.

The racial composition of the undergraduate population in fall 2007 was 35.3% White; 10.0% Black; 16.9% Hispanic; 19.9% Asian; 0.6% American Indian; 5.2% Alien; and 12.2% Unknown.

The table below shows five years of undergraduate fall enrollment.

<u>Year</u>	<u>2003</u>	<u>2004</u>	<u>2005</u>	<u>2006</u>	<u>2007</u>	<u>2008</u>
Undergraduate Total	5,712	5,366	5,263	5,380	5,428	n/a

The table below shows six years of new undergraduate transfer fall enrollment.

<u>Year</u>	<u>2003</u>	<u>2004</u>	<u>2005</u>	<u>2006</u>	<u>2007</u>	<u>2008</u>
Transfer Total	494	433	346	394	416	455*

*For this institution, the date the fall enrollment file was created differs from the date the new transfer file was created. This timing issue creates the number discrepancy between the total transfers in 2008 shown here and the total of numbers shown on the pie chart.

New Undergraduate Transfers Received by New Jersey Institute of Technology in Fall 2008

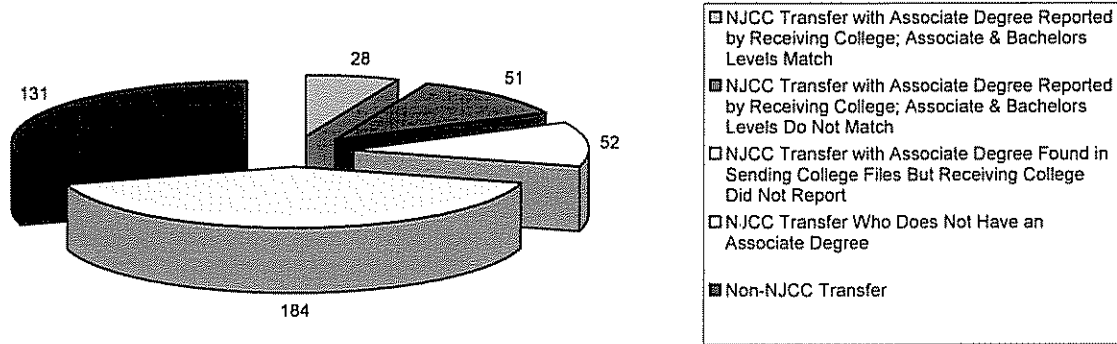

New Undergraduate Transfers from NJ Community Colleges to New Jersey Institute of Technology, Fall 2008

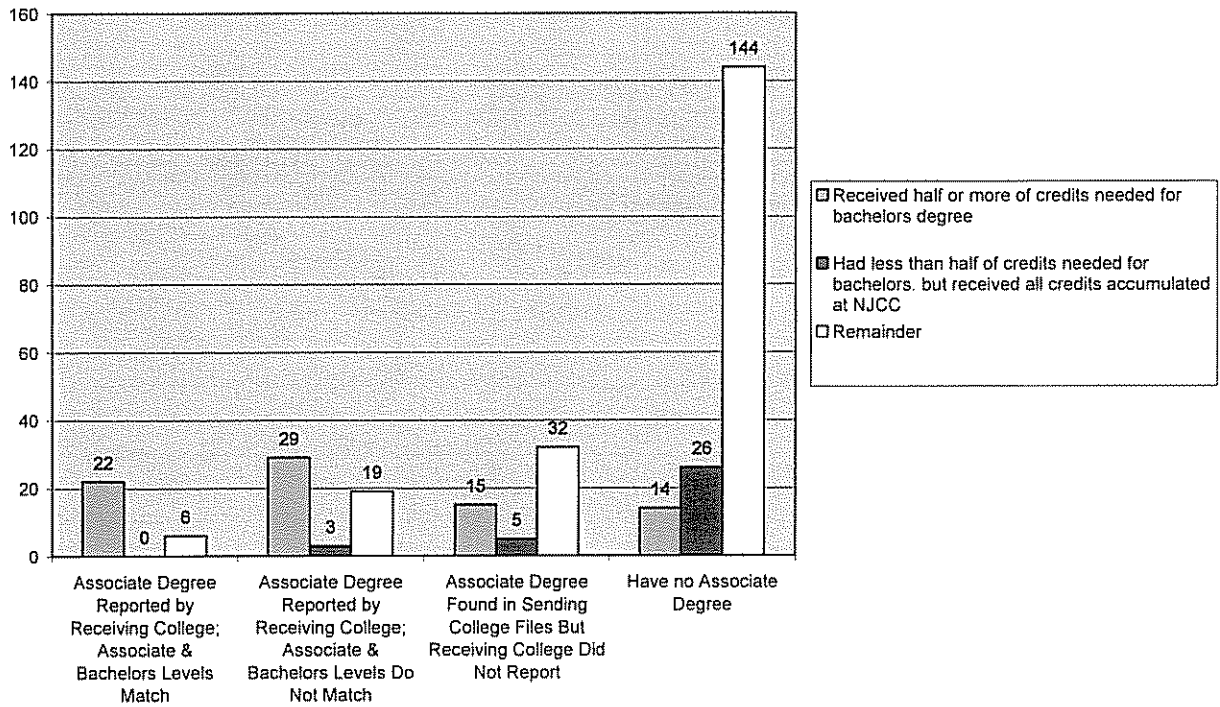

Home > Registrar > [Transfer Credit Evaluation](#)

Comprehensive State-Wide Transfer Agreement

The Comprehensive State-Wide Transfer Agreement exists to facilitate a seamless transition from NJ community colleges to NJ four-year colleges and universities.

Students who transfer to NJIT from any New Jersey county college should review the Comprehensive State-Wide Transfer Agreement (PDF) for guidelines concerning transferability of credits from New Jersey public community colleges to NJ public four-year institutions.

If a student feels that she/he has not received credit in accordance with this agreement, she/he may file an appeal for a review of the transfer credit in question. Download this Appeals Form: [NJ State-Wide Transfer Agreement \(PDF\)](#). Complete and submit to the Associate VP for Enrollment Services (currently Kathryn.kelly@njit.edu) by e-mail, hard copy or FAX (973 596-3461), within 30 days of receipt of the transfer credit evaluation.

The form must be fully completed or it will be returned without review. Details of the appeal will be reviewed by the NJIT Statewide Transfer agreement Appeals Committee. A decision will be rendered to the student within 30 days of the receipt of the appeal; NJIT reserves the right to divulge the nature of the appeal and the decision to the relevant community college. This decision will be final.

[Related Links](#)

[Info for Transfer Counselors](#)

New Jersey City University (NJCU)

Founded in 1929 as the New Jersey Normal School in Jersey City, Jersey City State College became New Jersey City University in 1998. It is located in Jersey City in Hudson County.

New Jersey City University offers 37 bachelor's degree programs.

Undergraduate enrollment in fall 2007 was 6,285 students: 4,471 full-time and 1,814 part-time.

The racial composition of the undergraduate population in fall 2007 was 26.8% White; 18.6% Black; 34.8% Hispanic; 6.7% Asian; 0.1% American Indian; 1.1% Alien; and 11.8% Unknown.

The table below shows five years of undergraduate fall enrollment.

<u>Year</u>	<u>2003</u>	<u>2004</u>	<u>2005</u>	<u>2006</u>	<u>2007</u>	<u>2008</u>
Undergraduate Total	6,174	6,018	6,004	6,158	6,285	n/a

The table below shows six years of new undergraduate transfer fall enrollment.

<u>Year</u>	<u>2003</u>	<u>2004</u>	<u>2005</u>	<u>2006</u>	<u>2007</u>	<u>2008</u>
Transfer Total	653	710	668	746	809	803

New Undergraduate Transfers Received by New Jersey City University in Fall 2008

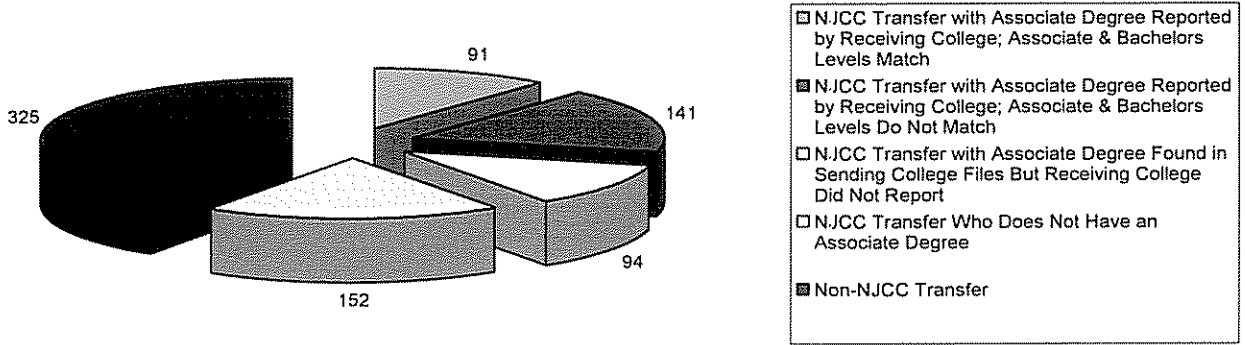

New Undergraduate Transfers from NJ Community Colleges to New Jersey City University, Fall 2008

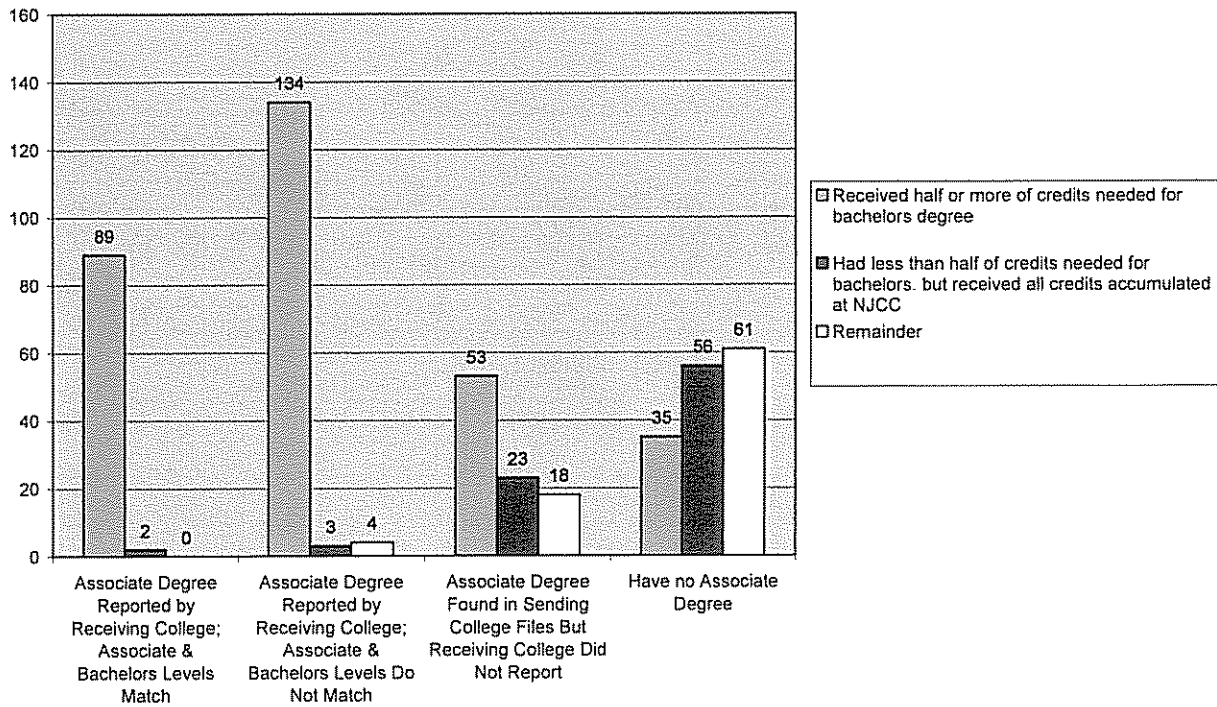

ACADEMICS

- > University Advisement Center
- > Testing Services
- > Transfer Resource Center
- > International Students and Study Abroad
- > Freshman Express Program
- > Veteran's Affairs
- > UAC Staff
- > E-Mail the Virtual Advisor
- > Advisement Tools
- > Information for Faculty
- > Articulation Agreements
- > GothicNet
- > **Calendar of Events**

APPLY ONLINE SET UP A VISIT PERSONALIZE

Transfer Resource Center

Francisco Forgett
Transfer Evaluator
University Advisement Center
201-200-3418

Eula Washington
Secretary
University Advisement Center
(201) 200-3395

Welcome to the Transfer Resource Center (TRC) The aim of the TRC is to provide services to both new and continuing transfer students. Services include campus tours, individualized advisement, professional and academic support program referrals, and a student mentor program

If you would like to request an evaluation of transfer credits, please click on the following link: <http://web.njcu.edu/sites/uactransfer/>

Advisory Tip

NJCU's Criminal Justice program is one of the most popular in the region. And our nursing program is also highly respected by students and employers.

Take a look at other programs



Comprehensive Statewide Transfer Agreement

For full text of the Comprehensive Statewide Transfer Agreement, endorsed by the NJ Presidents' Council, 9/22/08 [CLICK HERE](#)

TRANSFER STUDENT GRIEVANCE/APPEALS

In accordance with the Comprehensive Statewide Transfer Agreement* (hereafter known as the "Agreement"), transfer students at New Jersey City University can appeal a decision that he/she believes is not consistent with the Agreement.

The Agreement and accompanying appeals procedure are not intended to initiate a request for course substitutions. Students wishing to make such a request should file a "Request to Substitute General Studies Area Requirements" form

Appeals Procedure:

Appeals must include both the reason for appeal and all supporting documentation to verify course credit and placement.

The transfer student must file a written complaint with the Director of University Advisement Center within thirty days on any evaluation decision that the student is not in agreement, to the following email address: jduff@njcu.edu

Upon receipt of the Director's decision, which is due to the student within fifteen days of receipt, the student may appeal directly to the Vice President for Academic Affairs within ten days. The Vice President's decision is final and is due to the student within ten days of receipt.

All decisions will be communicated to the student via the student's NJCU email address and mailing address, which requires the student to establish a GothicNet ID and maintain a current, up-to-date mailing address prior to submitting the form.

[← previous page](#)

[back to top ↑](#)

NJCU DISCLAIMER | CONTACT WEBMASTER

New Jersey City University
2039 Kennedy Boulevard Jersey City, New Jersey 07305-1597
Undergraduate Admissions (888)441-NJCU Graduate Admissions 877-NJCUGRAD
Copyright © New Jersey City University All Rights Reserved

Transfer Student Grievance/Appeals

In accordance with the Comprehensive State Wide Transfer Agreement*, effective fall 2008, (hereafter known as the "Agreement") transfer students at New Jersey City University can appeal a decision that he/she believes is not consistent with the Agreement.

(This document and accompanying appeals procedure are not intended to initiate a request for course substitutions. Students wishing to make such a request should file a "Request to Substitute General Studies Area Requirements" form).

*Please see Transfer Resource Center website at http://www.njcu.edu/academics/advise_trcenter.asp for full text of the Comprehensive State Wide Transfer Agreement, 9/23/08.

Appeals procedure:

- Appeals must include both the reason for appeal and all supporting documentation to verify course credit and placement.
- The transfer student must file a written complaint with the Director of University Advisement Center within thirty days on any evaluation decision that the student is not in agreement, to the following email address: jduff@njcu.edu.
- Upon receipt of the Director's decision, which is due to the student within fifteen days of receipt, the student may appeal directly to the Vice President for Academic Affairs within five days. The Vice President's decision is final and is due to the student within ten days of receipt.
- All decisions will be communicated to the student via the student's NJCU email address and mailing address, which requires the student to establish a GothicNet ID and maintain a current, up-to-date mailing address prior to submitting this form.

DATE: _____

Name: _____

Student ID: _____

Name of community college attended _____

Statement of appeal (and accompanying documentation as required):

- units of laboratory science; the five additional units of academic electives must be from courses in the above college preparatory subjects and foreign languages. Candidates submitting a General Education Diploma (GED) must also provide official GED scores;
- Letters of recommendations from the secondary school principal or guidance counselor or teachers as to the character of the student and ability to undertake college work
 - Official SAT scores or ACT scores if you have been out of high school fewer than 5 years

SAT test applications are available in high school guidance offices or may be secured by writing to the College Entrance Examination Board, Box 592, Princeton, NJ 08540. The College Board code number for New Jersey City University is 2516 and should be noted on the test application. The test is administered frequently at conveniently located centers in the United States and foreign countries.

CLASS SCHEDULE

Students admitted as full-time freshmen are eligible to enroll in classes that are offered on a schedule of 8:00 a.m. to 9:50 p.m. A full-time student will normally average 32 semester hours each year, taking a minimum of 12 credit hours in any semester.

Admission for Part-Time Freshmen

The priority deadline for filing an application for undergraduate admissions is May 1 for the fall semester and November 1 for the spring semester. These dates are subject to extension at the discretion of the Admissions Office.

Part-time freshmen applicants are required to present the following credentials:

- An official high school transcript of work completed and in progress; or a photocopy of a GED diploma with official GED scores
- Official SAT scores or ACT scores if you have been out of high school fewer than 5 years

CLASS SCHEDULE

Students admitted as part-time freshmen are eligible to enroll in classes that are offered on a schedule of 8:00 a.m. to 9:50 p.m. A part-time student may register for credit loads ranging from 1 - 11 semester hours. A credit load exceeding 11 semester hours requires special approval. Upon com-

pletion of 12 college-level credits, a student may change his/her status from part-time to full-time by completing the Change of Enrollment Status form available in the University Advisement Center.

Freshmen Admission Programs

New Jersey City University will consider freshmen applicants who have been unable to pursue studies to the extent described above. The University admits some freshmen under a special admissions program that waives completion of some secondary school requirements. The University also admits approximately 100 freshmen annually through its Equal Opportunity Fund Program, known at New Jersey City University as the Opportunity Scholarship Program (OSP).

More information about OSP can be found on the page 11.

Admission for Full-Time and Part-Time Transfers

Each year, New Jersey City University accepts a number of transfer students from two-year and four-year institutions. Students interested in transferring to New Jersey City University as a full-time or part-time student should file their applications by May 1 for the fall semester and November 1 for the spring semester in order to meet the priority deadlines. These dates are subject to extension at the discretion of the Admissions Office.

Full-time and part-time transfer students are required to present the following credentials when they apply for admission to New Jersey City University:

- Official transcripts from each accredited institution previously attended showing cumulative grade point average (CGPA). Transfer applicants submitting less than 12 semester hours of acceptable credits are required to submit an official high school transcript along with scores from the SAT.
- A nurse applying for admission to degree study must submit a transcript(s) of his/her nursing school record and/or his/her study at any other college.

The only exception to these requirements is credits earned elsewhere at the time of New Jersey City University application. All final official transcripts from previously attended institutions must be submitted no later than October 15 for fall applicants and February 28 for spring applicants.

The transcripts of students admitted to New Jersey City University as transfer students, either for full-time or part-time study, will be evaluated by the University Advisement Center for application toward the Bachelor of Arts or Bachelor of Science degree. Transfer credits will be granted for courses carrying a letter grade of "C" or better and applicable to the student's degree requirements.

In accordance with the New Jersey Statewide Transfer Agreement (2007), New Jersey City University provides transfer students the opportunity for seamless transfer of credits from completed Associated in Arts (AA) and Associated in Science (AS) degrees from New Jersey community colleges, thereby satisfying the University's general education requirements up to a maximum of 64-66 credits, or half the required 128 credits for graduation.

A student may be required to take more than half of the credits necessary for graduation at the University if entrance into a required course at the University requires a prerequisite course which the student has not yet completed at the community college. Student holding associate (AA and AS) degrees will enter the University as juniors upon admission and will have completed all lower division general education requirements at the University. All junior and senior level courses required of a particular major program must be completed at New Jersey City University.

AA and AS students who transfer to New Jersey City University from an accredited college outside of New Jersey will have their transcripts evaluated on a course-by-course basis.

In order to receive transfer credits, courses must correspond to New Jersey City University course equivalencies, and courses must carry a letter grade of "C" or better (a numerical grade of 2.0 on a scale of 4.0). A maximum of 66 credits is transferable.

Transfer Student Grievance/ Appeals

In accordance with the Comprehensive Statewide Transfer Agreement* (hereafter known as the "Agreement"), transfer students at New Jersey City University can appeal a decision that he/she believes is not consistent with the Agreement.

The Agreement and accompanying appeals procedure are not intended to initiate a request for course substitutions. Students wishing to make such a request should file

a "Request to Substitute General Studies Area Requirements" form

*Please see Transfer Resource Center website at http://www.njcu.edu/academics/advise_trcenter.asp for full text of the Comprehensive Statewide Transfer Agreement, 9/22/08

Appeals Procedure:

- Appeals must include both the reason for appeal and all supporting documentation to verify course credit and placement
- The transfer student must file a written complaint with the Director of University Advisement Center within thirty days on any evaluation decision that the student is not in agreement, to the following email address: jduff@njcu.edu
- Upon receipt of the Director's decision, which is due to the student within fifteen days of receipt, the student may appeal directly to the Vice President for Academic Affairs within ten days. The Vice President's decision is final and is due to the student within ten days of receipt
- All decisions will be communicated to the student via the student's NJCU email address and mailing address, which requires the student to establish a GothicNet ID and maintain a current, up-to-date mailing address prior to submitting this form

Admission for Full-Time and Part-Time Re-Entrants

Students who withdraw in good standing and wish to return to the University to complete their studies within three academic semesters of interrupting their studies should report to their departments or to the University Advisement Center to register for classes. Students who have not enrolled for more than three academic semesters must file an application for readmission with the Office of Undergraduate Admissions. This application should be submitted before May 1 for the fall semester, or by November 1 for the spring semester. Applications received after these dates will be processed according to the availability of space.

Students who have attended any other colleges or universities since last attending New Jersey City University must forward official transcripts from these institutions to the Office of Undergraduate Admissions at New Jersey City University.

Part-Time Certification Program

Students interested in working toward completing a teacher certification program on a part-time basis should contact the Office of Undergraduate Admissions for an application. Individuals who have already received an undergraduate degree at an accredited college or university and who wish to take courses to enable them to meet requirements for the New Jersey Teacher Certification "Certificate Program." A special program is developed in each case and it is advisable to consult the appropriate department before making a formal application for admission. In all teacher certification programs, those students who have not successfully completed a student teaching experience prior to admission to study must be prepared to spend one semester of full-time study to complete the approved certification program. Certification students must apply for Junior and Senior Field Experience courses immediately after registration. A student must have obtained an undergraduate CGPA of 2.75 to be considered for a Teacher Certification Program.

Admission to a part-time certificate program does not constitute admission to a baccalaureate degree program. A part-time student admitted to study in a certificate program who wishes to complete an undergraduate degree must apply for admission to a degree program.

Part-Time Non-Classified Study

Students interested in taking courses on a part-time basis for personal or professional enrichment may choose from a broad range of classes offered from 8:00 a.m. to 9:50 p.m. Such students will register as non-classified students and need to submit:

1. An application for admission to part-time study
2. An official high school transcript of work completed or a photocopy of a GED diploma with official GED scores

Students admitted on a part-time non-classified basis will not be considered eligible for federal or state financial aid.

International Students

International students must present the following credentials along with the completed application:

1. Official transcript(s) of all secondary school work completed. Transcript(s)

should identify the institution attended and show dates of attendance, examinations passed, grades given (official), and the degree awarded. It is the responsibility of the student to have the transcript(s) evaluated by an accredited international academic credentialing service.

2. Official transcript(s) of all post-secondary institutions attended. It is the responsibility of the student to have the transcript(s) evaluated by an accredited international academic credentialing service.
3. Official Scholastic Aptitude Test (SAT) or American College Test (ACT) scores (Code No. 2516 for SAT and No. 2570 for ACT). If the language of instruction is not in English, the applicant should also submit scores from the Test of English as a Foreign Language (TOEFL).
4. Documentation of financial resources sufficient to meet all educational and living expenses while in the United States.

In addition to the application for admission, international students must also complete a Foreign Student Supplement.

For specific information about student visas or any other topic of importance to international students, please call our International Student Advisor at (201) 200-2089.

Visiting Students

Students enrolled at other colleges who wish to take courses at New Jersey City University need only submit an official letter from the college they are currently attending approving such study. The letter should specify the course(s) authorized by the other institution.

Notification of Decision

The Admissions Office will notify the prospective student of its decision approximately one to two weeks after the candidate's file is complete. Upon acceptance to the University, all full-time and part-time students will be required to submit a non-refundable \$50.00 tuition deposit and a self-completed health form with specific immunization records attached.

Ramapo College of New Jersey

Founded in 1969, Ramapo College is a liberal arts college. It is located in Mahwah in Bergen County.

Ramapo offers 36 bachelor's degree programs.

Undergraduate enrollment in fall 2007 was 5,393 students: 4,795 full-time and 598 part-time.

The racial composition of the undergraduate population in fall 2007 was 78.8% White; 5.8% Black; 8.6% Hispanic; 4.2% Asian; 0.3% American Indian; 2.8% Alien; and 0.0% Unknown.

The table below shows five years of undergraduate fall enrollment.

Year	2003	2004	2005	2006	2007	2008
Undergraduate Total	5,242	5,278	5,233	5,188	5,393	n/a

The table below shows six years of new undergraduate transfer fall enrollment.

Year	2003	2004	2005	2006	2007	2008
Transfer Total	498	491	472	584	606	621

New Undergraduate Transfers Received by Ramapo College in Fall 2008

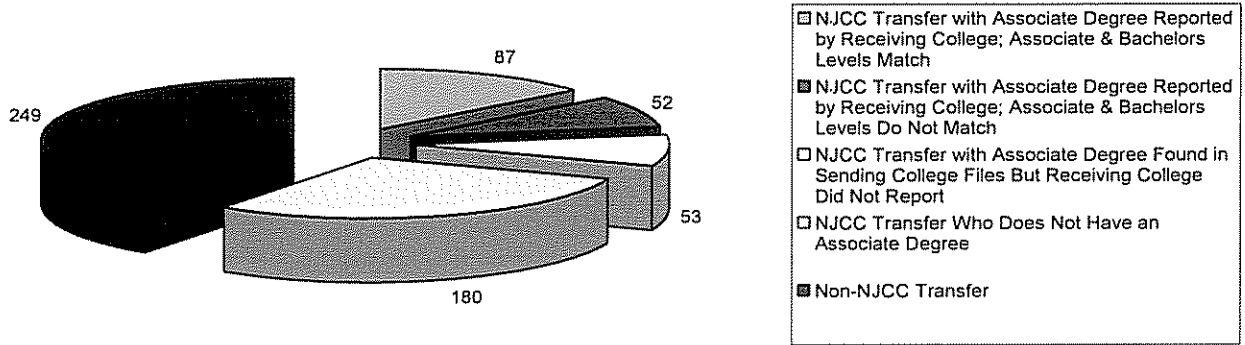

New Undergraduate Transfers from NJ Community Colleges to Ramapo College, Fall 2008

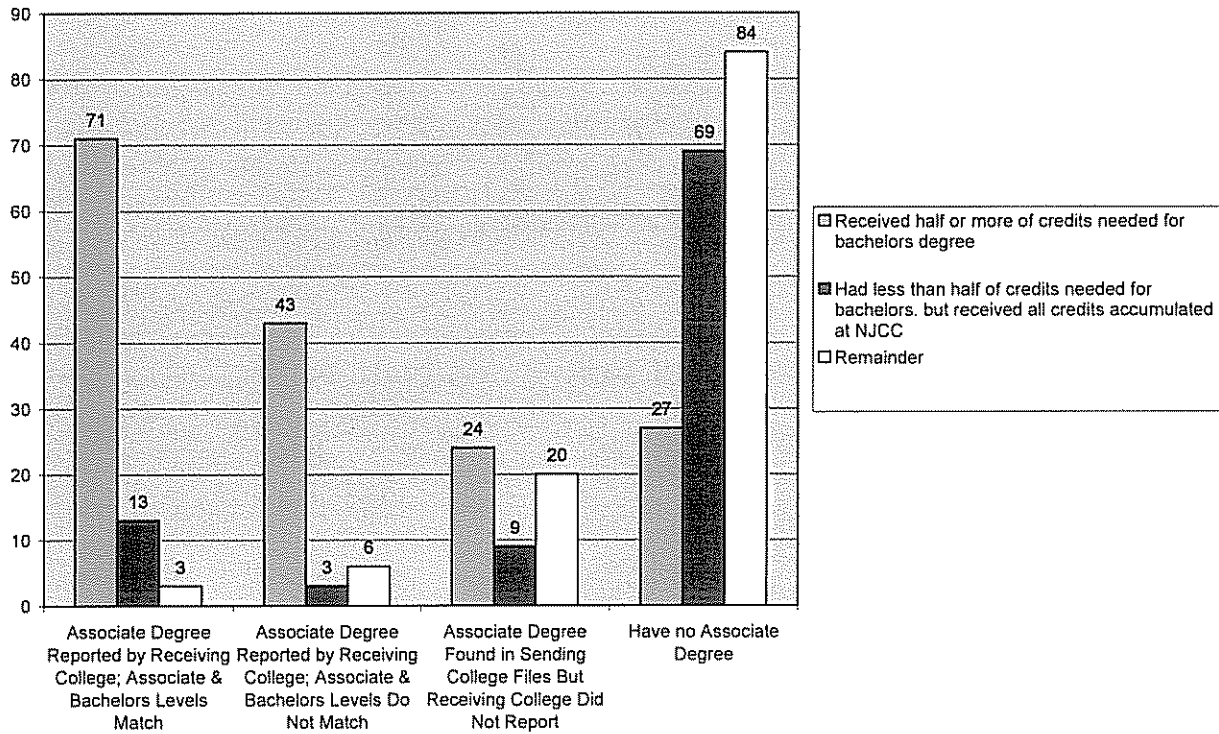

Ramapo College's New Jersey Statewide Transfer Agreement Appeals Process

Students who wish to appeal a perceived misinterpretation of the policies agreed upon in the NJ Statewide Transfer Agreement must submit a written appeal to the Director of the Center for Academic Advising/First Year Experience (CAAFYE) within 30 days of receiving his/her credit evaluation.

The appeal will be reviewed by the College's NJSTA appeals committee. The CAAFYE director will then provide a decision to the student within 14 days of receipt of the appeal. Appeals should be submitted electronically to caafye@ramapo.edu. They must include the reason for the appeal and any needed documentation supporting the request.

All decisions will be communicated to the student via the student's Ramapo College email account, which requires the student to establish and regularly maintain a Ramapo e-mail account prior to submitting the appeal.

Update: December 16, 2008

The Richard Stockton College of New Jersey (Stockton)

Stockton was founded in 1971. It is located in Pomona in Atlantic County.

Stockton offers 40 bachelor's degree programs.

Undergraduate enrollment in fall 2007 was 6,767 students: 5,873 full-time and 894 part-time.

The racial composition of the undergraduate population in fall 2007 was 78.2% White; 8.2% Black; 5.8% Hispanic; 5.0% Asian; 0.4% American Indian; 0.5% Alien; and 1.9% Unknown.

The table below shows five years of undergraduate fall enrollment.

Year	2003	2004	2005	2006	2007	2008
Undergraduate Total	6,540	6,578	6,571	6,726	6,767	n/a

The table below shows six years of new undergraduate transfer fall enrollment.

Year	2003	2004	2005	2006	2007	2008
Transfer Total	830	865	868	1,019	987	846

New Undergraduate Transfers Received by Richard Stockton College in Fall 2008

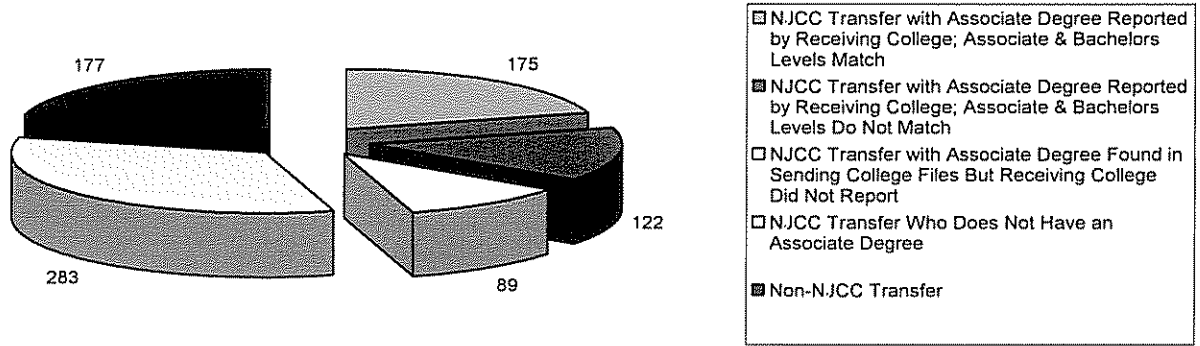

New Undergraduate Transfers from NJ Community Colleges to Richard Stockton College, Fall 2008

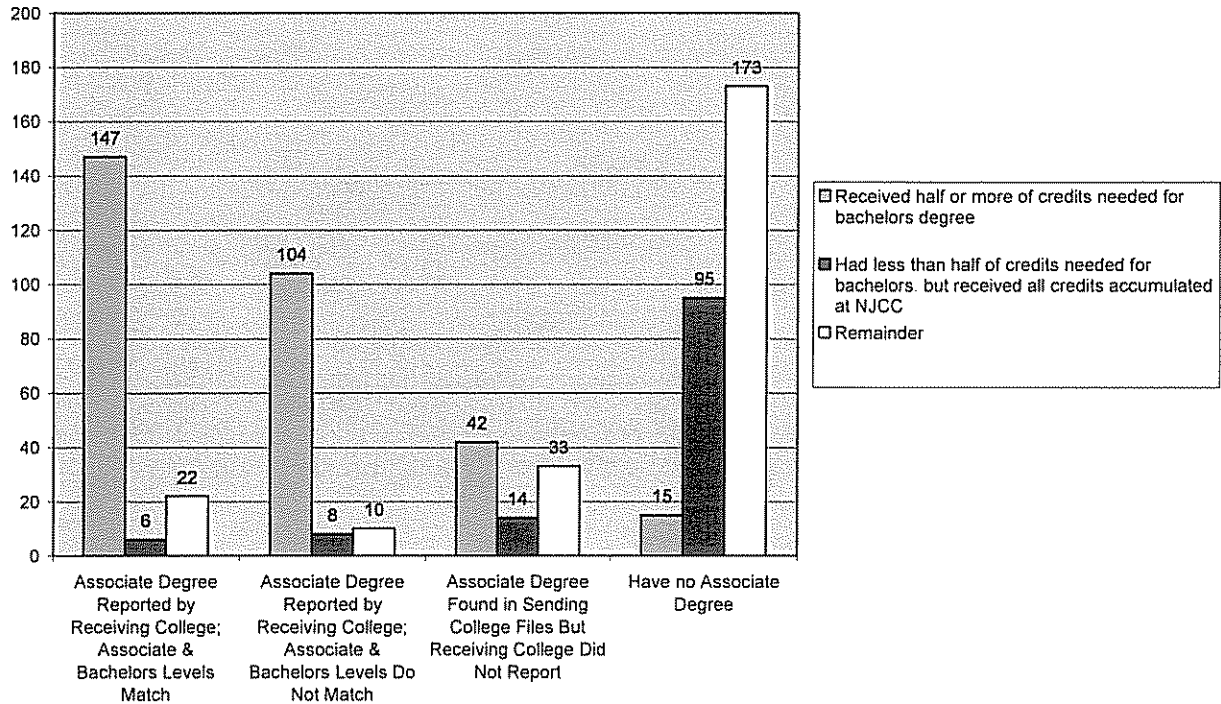

Academic Affairs

The Richard Stockton College of New Jersey

Policies & Procedures - Transfer Credit

[Home](#) > [Policies & Procedures](#) > [Transfer Credit](#)

Transfer from Four-Year Colleges

Graduates of NJ County/Community Colleges

Other Two-Year Colleges

Transfer into BSN

Credit for Nontraditional Experience

Transfer of International Credits

Transfer Credit After Matriculation

Other Course Work

Advanced Placement Program

Standardized College-Level Exams

Appeal Process

TRANSFER CREDIT POLICIES

Acceptance of credits in transfer does not guarantee that those credits will be applicable to the program chosen by the student. The Office of the Registrar, the Center for Academic Advising and the preceptor evaluate credits with regard to both acceptability and applicability. Only official transcripts, official score reports and official evaluations of foreign credits shall be used for this review. Transfer students must meet the same overall academic standards and requirements as students who enter Stockton as freshmen.

To be accepted in transfer, courses must have been taken at a regionally accredited institution, must have been completed within the last 20 years, must have been taken for a letter grade and the grade earned must be a C or higher (where the C grade has the numerical equivalent of at least 2.0 on a 4.0 point scale), must be a college-level course and must be the substantial equivalent of a course offered at Stockton. Grades from transfer courses are not used to calculate the Stockton grade-point average; only the course credits transfer. When a transfer course does not have the same credit value as its closest Stockton equivalent course, the course may still be used to fulfill a specific degree or program requirement. All aggregate credit requirements must be met.

Stockton programs may place further restrictions on the acceptance of transfer credits in order to maintain the integrity of Stockton's degree programs. For this reason, courses such as professional education, practica, internships, and fieldwork courses taken at other institutions may not transfer. Some programs may specify that certain courses be completed more recently

than 20 years ago.

Transfer from Four-Year Colleges A maximum of 96 credits may be accepted in transfer from regionally accredited four-year colleges and universities.

Transfer of Graduates from a New Jersey County/Community College Stockton participates in the "Comprehensive State-Wide Transfer Agreement" and has endorsed the General Education Foundation for A.A. and A.S. Transfer Programs in New Jersey's Community Colleges. Thus, a graduate of an approved transfer program of a New Jersey county/community college or of the associate's degree program of Thomas Edison State College is granted the full amount of the minimum total number of credits required for graduation in that degree program, up to a maximum of 64 credits. In this way, courses that ordinarily would not transfer (e.g., those with grades of C minus or D, or physical education courses) are allowed in transfer as part of the A.A. or A.S. degree. However, minimum grades for specific Stockton requirements must still be met.

Acceptance of credits in transfer does not guarantee that those credits will be applicable to the program chosen by the student. In cases where the degree is granted for fewer than 64 credits, only that number will be awarded in transfer.

To be eligible for the maximum 64 transfer credits a student must have earned an associate in arts or science degree in an approved transfer program offered at Stockton. If Stockton credits are used to earn the A.A. or A.S. degree, such credits are subtracted from the maximum allowable under the State-Wide Agreement.

Stockton generally regards the associate in applied science (A.A.S.) degree as a terminal technical or professional degree and does not transfer it in its entirety, unless Stockton offers the same program at the baccalaureate level. Instead, the credits are reviewed on a course-by-course basis.

Transfer from Other Two-Year Colleges A maximum of 64 credits may be transferred from regionally accredited two-year colleges.

Transfer to the Bachelor of Science in Nursing A maximum of 66 credits is allowed in transfer from a regionally accredited two-year college when the student has earned an associate's degree and has been accepted for matriculation in Stockton's two-year Bachelor of Science in Nursing completion program.

Credit for Nontraditional Experience The Provost or his/her designee may authorize non-regionally accredited formal course work for transfer upon review of relevant transcripts and other supportive materials, and only with the positive written recommendation of the student's

program coordinator and the College dean. Such credits, if granted, are only to be used for program requirements. No credit is granted for life experience.

Transfer of International Credits Credits from colleges and universities outside the United States must be equated to those at regionally accredited U.S. colleges and universities. It shall be the responsibility of the student making application to Stockton to furnish the College with an original certified copy of an evaluation of his/her international credits performed by World Educational Services, or an equivalent service approved by the Office of the Registrar. The acceptability of credits is governed by the same principles stated above.

Transfer Credit after Matriculation Once a student has matriculated at Stockton, credits from other institutions will only be awarded if special permission is granted prior to registration. Such permission must be approved by the student's assigned preceptor, the Center for Academic Advising and, in the case of summer course work, the Dean of General Studies. Such permission will not be granted for any student who has lower than a 2.00 cumulative average at Stockton, for any student who proposes to take a course for which he/she has previously received a grade of lower than C at Stockton, for any student who has 96 earned credits, nor for any student who has 64 earned credits and proposes to take courses at a two-year institution. Moreover, approvals to take courses elsewhere in the summer must be obtained prior to the opening of Stockton's summer sessions. The policies governing acceptability of credits are the same as stated above.

Other Course Work Approved Stockton Education Abroad programs, the Washington Internship Seminar, and Dual-Degree Engineering and Health Profession programs shall be listed on the Stockton transcript as transfer credits.

Advanced Placement Program Through participation in the Advanced Placement program of the College Entrance Examination Board, a student may transfer up to 32 credits from high school experience. Variable credits will be granted at the freshman/sophomore level for each Advanced Placement examination for which a score of 3 or higher is achieved, except in Biology where a score of 4 or higher is required. Application of these credits to a specific College or program requirement is determined by the appropriate General Studies or program faculty.

STANDARDIZED COLLEGE-LEVEL EQUIVALENCY EXAMINATIONS

College Level Examination Program (CLEP) As of July 1, 2001, CLEP Examinations became available only in a computerized format, and the tests were revised. CLEP Exams taken after this date and in the new format are reviewed as follows:

Stockton awards credit for CLEP Exams if the student achieves a minimum score of 50. The amount of credits will be granted according to the same credit value as the equivalent course at

Stockton. Some CLEP Exams are designed to cover more than one semester of work.

A list of all CLEP Exams along with sample test questions is available via the College Board Web site www.collegeboard.com/clep/exams/

A list of CLEP Exams and their Stockton course equivalencies is available in the Preceptor's Resource Guide and in the Center for Academic Advising. Additional credits may be approved by the program faculty of the pertinent degree program if students have higher scores than 50 and if the work completed covers more than one semester.

No more than 32 credits will be accepted in Advanced Placement (AP) credit, CLEP credit or combination thereof. Since not all subject examinations are acceptable for credit at Stockton, the student is urged to contact the Center for Academic Advising for assistance on all questions related to CLEP credits.

Thomas Edison College Examination Program (TECEP) Stockton accepts as transfer credits those that are earned through the Thomas Edison College Examination Program (TECEP). For each TECEP examination, a study guide is prepared that outlines in detail the content of the examination and gives suggestions for effective preparation. Study guides are available from: Thomas Edison State College, Registrar, 101 West State Street, Trenton, NJ 08608-1176. www.tesc.edu

Information on the specific TECEP examinations accepted at Stockton is available at the Center for Academic Advising.

Appeal Process A student who wishes to appeal a decision regarding the acceptance of transfer credits must file a written appeal with the Office of the Provost. Such an appeal must be submitted by the student within 30 days of receiving the decision in question. The Provost or his/her designee will provide a decision to the student within 60 days of receipt of the appeal, and this decision is final. For students who appeal under the conditions of the State-Wide Agreement, the relevant community college will be informed of the nature of the appeal and the decision



© Copyright
The Richard Stockton College of NJ, PO Box 195, Pomona, NJ 08240
609-652-1776

Rowan University

Founded in 1923 as a normal school, Rowan University (formerly Glassboro State College) is a comprehensive university. In July 1992, industrialist Henry Rowan and his wife, Betty, donated \$100 million to the institution. Later that year, the school changed its name to Rowan College of New Jersey. The college achieved university status in 1997 and changed its name to Rowan University. It is located in Glassboro in Gloucester County.

Rowan offers 53 bachelor's degree programs.

Undergraduate enrollment in fall 2007 was 8,912 students: 7,675 full-time and 1,237 part-time.

The racial composition of the undergraduate population in fall 2007 was 78.1% White; 8.2% Black; 7.0% Hispanic; 3.0% Asian; 0.4% American Indian; 0.7% Alien; and 2.6% Unknown.

The table below shows five years of undergraduate fall enrollment.

Year	2003	2004	2005	2006	2007	2008
Undergraduate Total	8,311	8,385	8,484	8,430	8,912	n/a

The table below shows six years of new undergraduate transfer fall enrollment.

Year	2003	2004	2005	2006	2007	2008
Transfer Total	796	682	826	807	930	942*

*For this institution, the date the fall enrollment file was created differs from the date the new transfer file was created. This timing issue creates the number discrepancy between the total transfers in 2008 shown here and the total of numbers shown on the pie chart.

New Undergraduate Transfers Received by Rowan University in Fall 2008

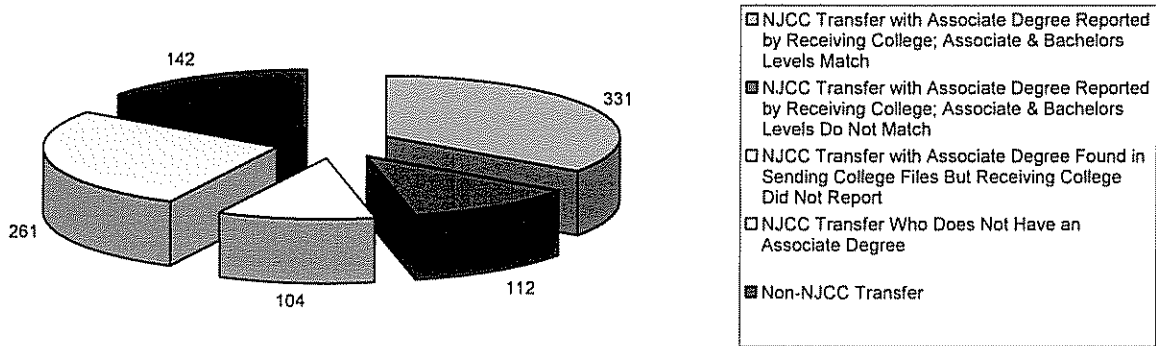

New Undergraduate Transfers from NJ Community Colleges to Rowan University, Fall 2008

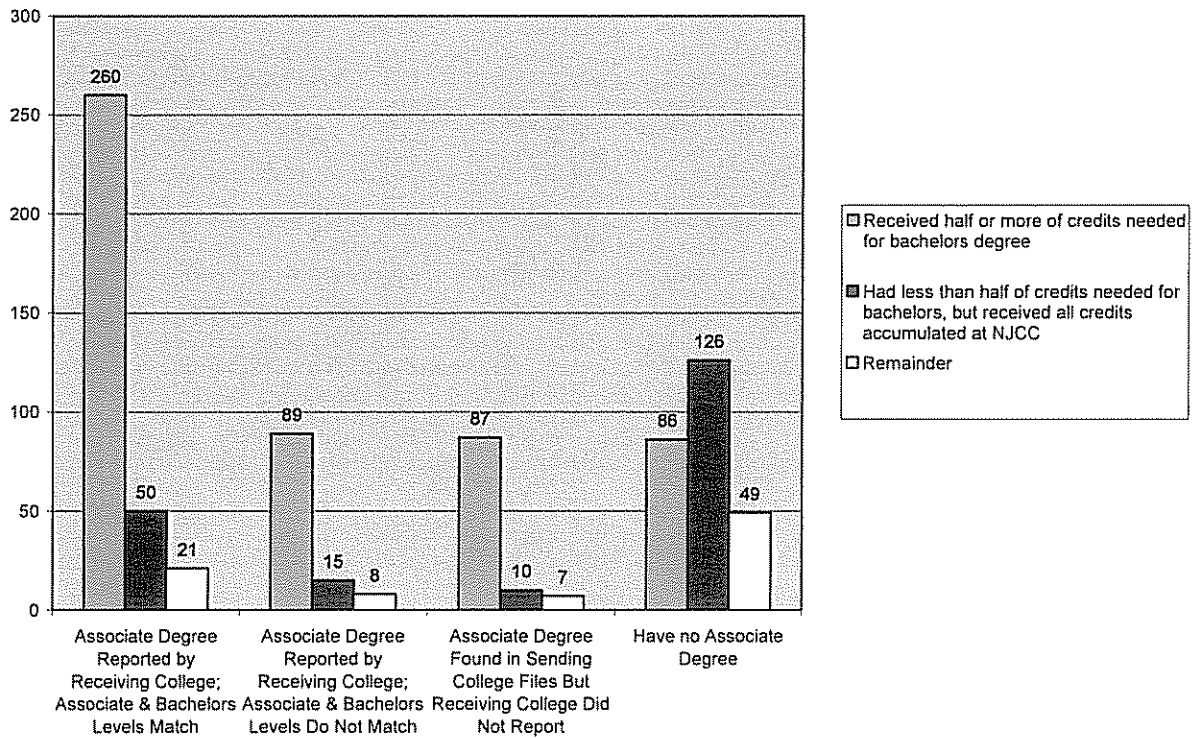



NJ Statewide Transfer Agreement Appeals Process

Students who have earned an Associate Degree from an accredited New Jersey Community College, have presented an official credential indicating award of an AA or AS degree, have received a Rowan University transfer credential evaluation and program guide, and wish to discuss the allocation of credits may consult their program advisor. Should this initial consultation fail to adequately resolve student concerns, the student has the right to petition the Rowan University's Transfer Agreement Appeals Committee by submitting an official request to appeal to the student's Academic Chair. Appeals will be considered within thirty days of filing.

(This process is separate and apart from the process required to initiate a request for course substitutions or waivers. Students wishing to make such a request should consult their academic advisor.)

Appeals procedure:

Appeals must include detailed reference to perceived contradictions between points and passages within the Statewide Agreement and the credential evaluation, the desired outcome, and supporting documentation to verify course credit and placement.

All appeals must be submitted to the Academic Chair of your major and discipline.

The petition will be reviewed by the student's Associate Dean, Academic Chair, the Academic Chair(s) under which the course(s) would be delivered within Rowan, and University Registrar.

Appeals will be considered within thirty days of receipt by the Academic Chair. The petition to appeal must be submitted to the chair within thirty days of receiving the initial evaluation of transfer credit. The Appeals Committee will respond to the student's petition and will *include the actual date it is filed with the University*. All decisions will be communicated to the student via the student's University email address. The community college listed within the appeal may be issued a copy of the appeal decision.

Community College: _____

Degree Earned: _____

By signing below, I attest to having read the COMPREHENSIVE STATE-WIDE TRANSFER AGREEMENT <http://www.njpc.org/newsandupdates/comprehensiveTransferApproved.html> or <http://www.state.nj.us/highereducation/PDFs/XferAgreementOct08.pdf>

Name: _____

Rowan ID : _____ Rowan Major: _____ Date: _____

Rutgers, The State University of New Jersey (Rutgers)

Founded in 1766 as Queens College, Rutgers is a comprehensive public research university. Rutgers grew to become the land-grant college of New Jersey in 1864 and to assume full university status in 1924. The University of Newark merged with Rutgers in 1946, and the College of South Jersey in Camden joined in 1950. Its main campus is in New Brunswick in Middlesex County. It has two additional major campus locations in Camden and Newark.

Undergraduate enrollment for all campuses in fall 2007 was 37,204 students: 32,997 full-time and 4,207 part-time.

The racial composition of the undergraduate population in fall 2007 was 49.1% White; 11.7% Black; 10.0% Hispanic; 22.6% Asian; 0.2% American Indian; 1.6% Alien; and 4.7% Unknown.

Narrative for CHE's Transfer Report (12-17-08)

Rutgers has made a determined effort to implement the Statewide Transfer Agreement across its three main campuses and many undergraduate schools. However, because of differing interpretations of the agreement's expectations and shortcomings in data collection, the graphs and tables presented in this report do not adequately reflect the successful implementation of the transfer agreement at New Jersey's state university. Of particular concern is the gen-ed program for students seeking full transfer credit at a senior public institution, which is stipulated in the agreement but not addressed in the Commission's analysis. This is a major issue at Rutgers, where approximately forty percent of all community college graduates transferring this fall to the New Brunswick School of Arts and Sciences (a popular transfer destination) were found lacking in the gen-ed requirement and, thus, denied certain transfer credits. Fortunately, this gen-ed issue will likely subside over time as the Statewide Transfer Agreement is fully implemented at the sending institutions, most of which are currently aligning their curricular requirements with the agreement. In addition to the gen-ed matter, delays in receiving final transcripts and degree certifications from the sending colleges may have also distorted some of the transfer data in this report. Case in point: within six weeks after the initial Commission deadline for Fall 2008 transfer data, approximately 80 additional transfer students at Rutgers had their final transcripts reviewed and were granted the full transfer credit called for in the agreement. Constructing a state-wide integrated data system (with standardized electronic transcripts from all sending colleges) would resolve many of these issues.

Rutgers University-New Brunswick

Rutgers-New Brunswick offers 102 bachelor's degree programs.

Undergraduate enrollment in fall 2007 was 26,829: 24,876 full-time and 1,953 part-time.

The racial composition of the undergraduate population in fall 2007 was 52.2% White; 9.1% Black; 8.4% Hispanic; 24.4% Asian; 0.2% American Indian; 1.7% Alien; and 3.9% Unknown.

The table below shows five years of undergraduate fall enrollment.

<u>Year</u>	<u>2003</u>	<u>2004</u>	<u>2005</u>	<u>2006</u>	<u>2007</u>	<u>2008</u>
Undergraduate Total						
Rutgers-New Brunswick	27,365	26,813	26,713	26,691	26,829	n/a

The table below shows six years of new undergraduate transfer fall enrollment.

<u>Year</u>	<u>2003</u>	<u>2004</u>	<u>2005</u>	<u>2006</u>	<u>2007</u>	<u>2008</u>
Transfer Total						
Rutgers-New Brunswick	1,890	1,895	1,759	1,850	1,477	1,694

New Undergraduate Transfers Received by Rutgers-New Brunswick in Fall 2008

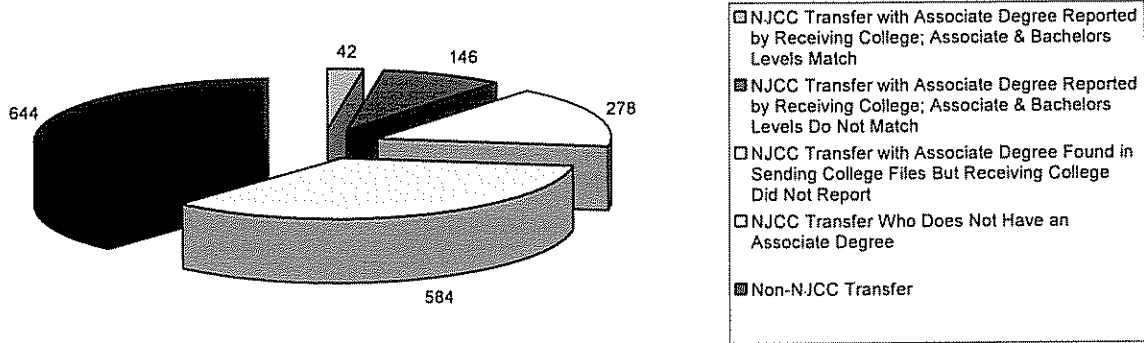

New Undergraduate Transfers from NJ Community College to Rutgers-New Brunswick, Fall 2008

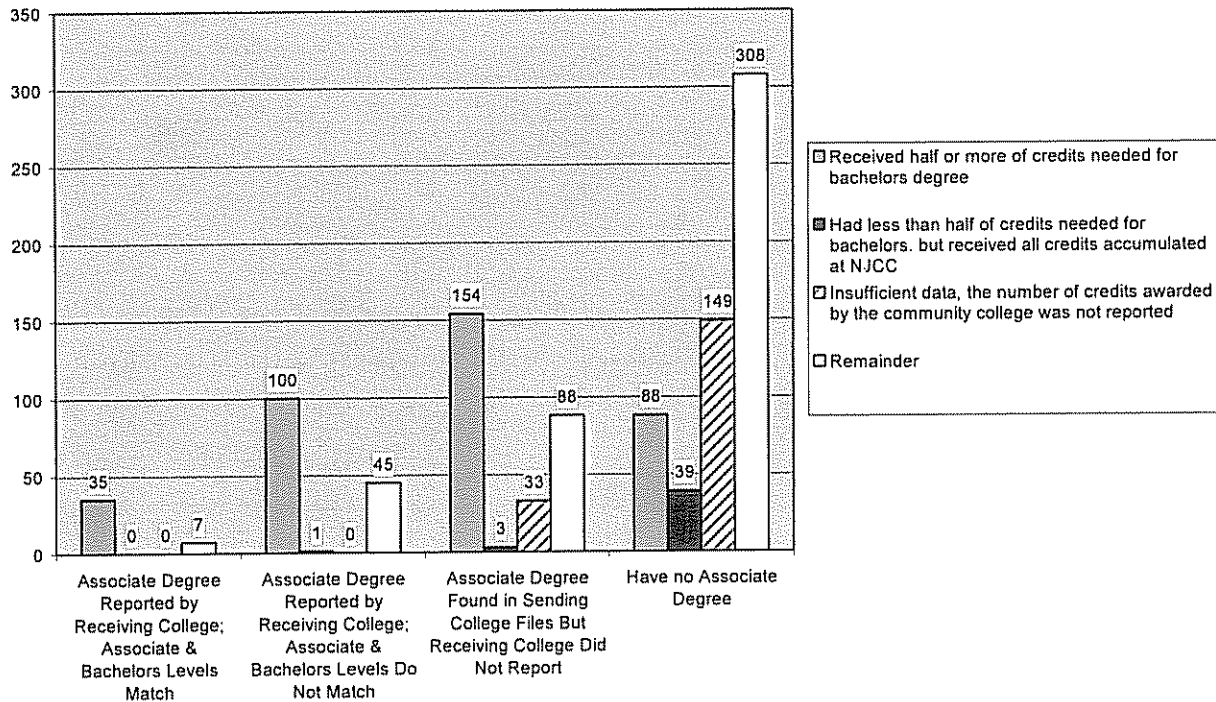

Rutgers University-Newark

Rutgers-Newark offers 58 bachelor's degree programs.

Undergraduate enrollment in fall 2007 was 6,685: 5,212 full-time and 1,473 part-time.

The racial composition of the undergraduate population in fall 2007 was 28.0% White; 19.2% Black; 18.4% Hispanic; 23.6% Asian; 0.3% American Indian; 1.9% Alien; and 8.7% Unknown.

The table below shows five years of undergraduate fall enrollment.

Year	2003	2004	2005	2006	2007	2008
Undergraduate Total						
Rutgers-Newark	6,784	6,608	6,513	6,503	6,685	n/a

The table below shows six years of new undergraduate transfer fall enrollment.

Year	2003	2004	2005	2006	2007	2008
Transfer Total						
Rutgers-Newark	524	512	573	650	692	763

New Undergraduate Transfers Received by Rutgers- Newark in Fall 2008

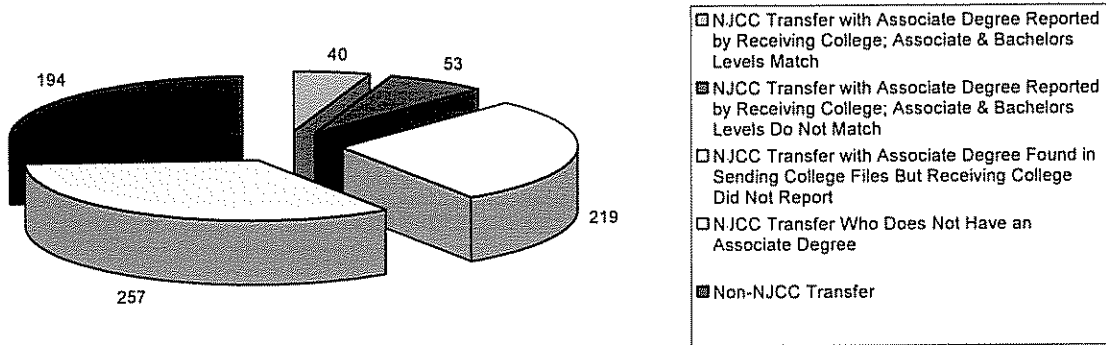

New Undergraduate Transfers from NJ Community Colleges from Rutgers-Newark, Fall 2008

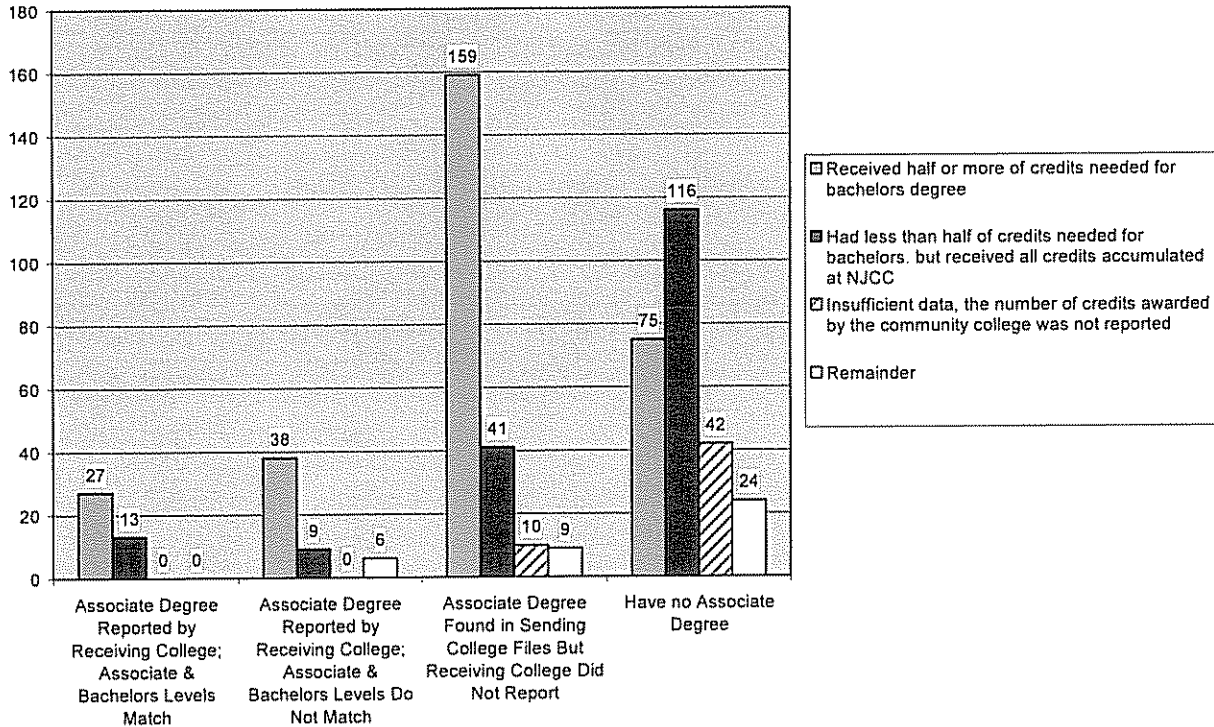

Rutgers University–Camden

Rutgers-Camden offers 36 bachelor’s degree programs.

Undergraduate enrollment in fall 2007 was 3,690: 2,909 full-time and 781 part-time.

The racial composition of the undergraduate population in fall 2007 was 64.7% White; 17.1% Black; 6.9% Hispanic; 7.6% Asian; 0.3% American Indian; 0.3% Alien; and 3.2% Unknown.

The table below shows five years of undergraduate fall enrollment.

Year	2003	2004	2005	2006	2007	2008
Undergraduate Total						
Rutgers-Camden	3,969	4,007	3,846	3,694	3,690	n/a

The table below shows six years of new undergraduate transfer fall enrollment.

Year	2003	2004	2005	2006	2007	2008
Transfer Total						
Rutgers-Camden	585	566	573	590	581	719

New Undergraduate Transfers Received by Rutgers-Camden in Fall 2008

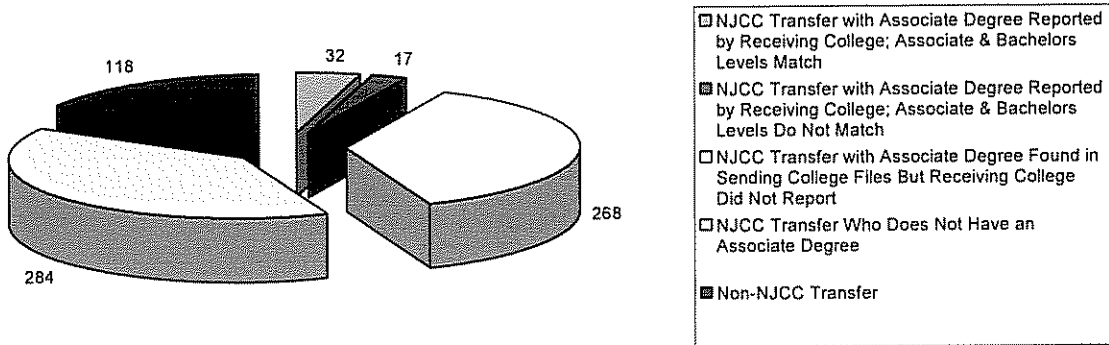

New Undergraduate Transfers from NJ Community Colleges to Rutgers-Camden, Fall 2008

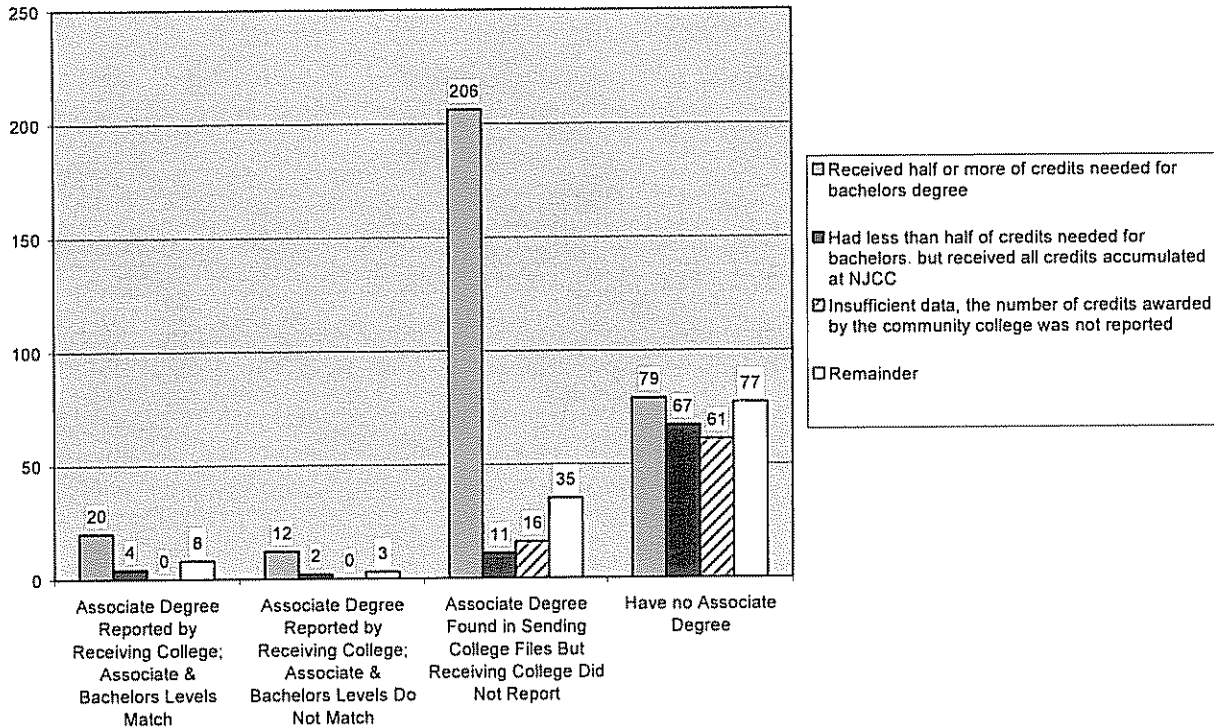

RUTGERS: Transfer Appeals Process

The schools of Arts and Sciences and the relevant professional schools (Nursing, Business, and Engineering) on Rutgers' campuses in Camden, Newark, and New Brunswick are currently refiguring their websites to showcase the transfer agreement and the appeals process should any transfer student from community colleges encounter difficulties. All sites will not only have full texts of the agreement; each site will also indicate the appeals procedures and the person(s) to contact via email or telephone to set the appeals process in motion. Websites on all our campuses featuring this material will be "live" by 19 January, the opening of the spring term.

The College of New Jersey (TCNJ)

Founded in 1855, as the New Jersey State Normal School, The College of New Jersey (formerly Trenton State College) is located in Ewing Township in Mercer County.

The College of New Jersey offers 50 bachelor's degree programs.

Undergraduate enrollment for fall 2007 was 6,205 students: 6,028 full-time and 177 part-time.

The racial composition of the undergraduate population in fall 2007 was 72.5% White; 6.2% Black; 8.4% Hispanic; 7.5% Asian; 0.1% American Indian; 0.4% Alien; and 5.0% Unknown.

The table below shows five years of undergraduate fall enrollment.

<u>Year</u>	<u>2003</u>	<u>2004</u>	<u>2005</u>	<u>2006</u>	<u>2007</u>	<u>2008</u>
Undergraduate Total	5,938	5,918	5,895	6,094	6,205	n/a

The table below shows six years of new undergraduate transfer fall enrollment.

<u>Year</u>	<u>2003</u>	<u>2004</u>	<u>2005</u>	<u>2006</u>	<u>2007</u>	<u>2008</u>
Transfer Total	185	234	259	320	273	262

New Undergraduate Transfers Received by The College of New Jersey in Fall 2008

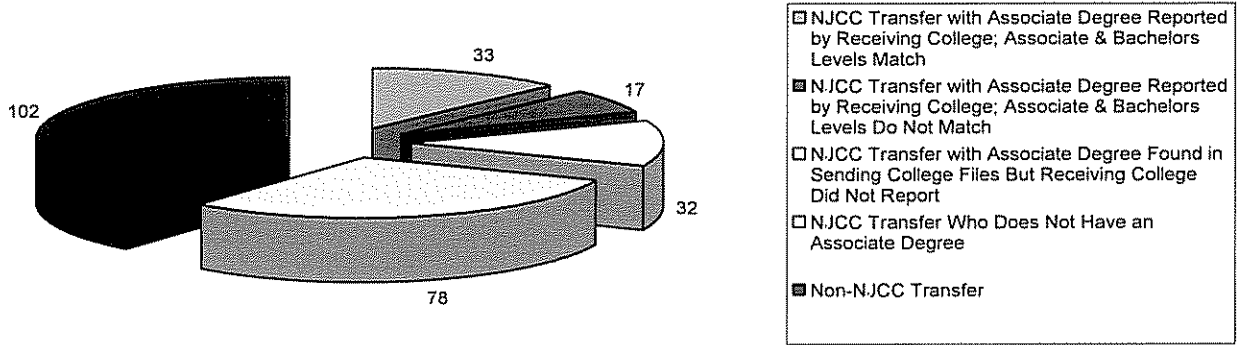

New Undergraduate Transfers from NJ Community Colleges to The College of New Jersey, Fall 2008

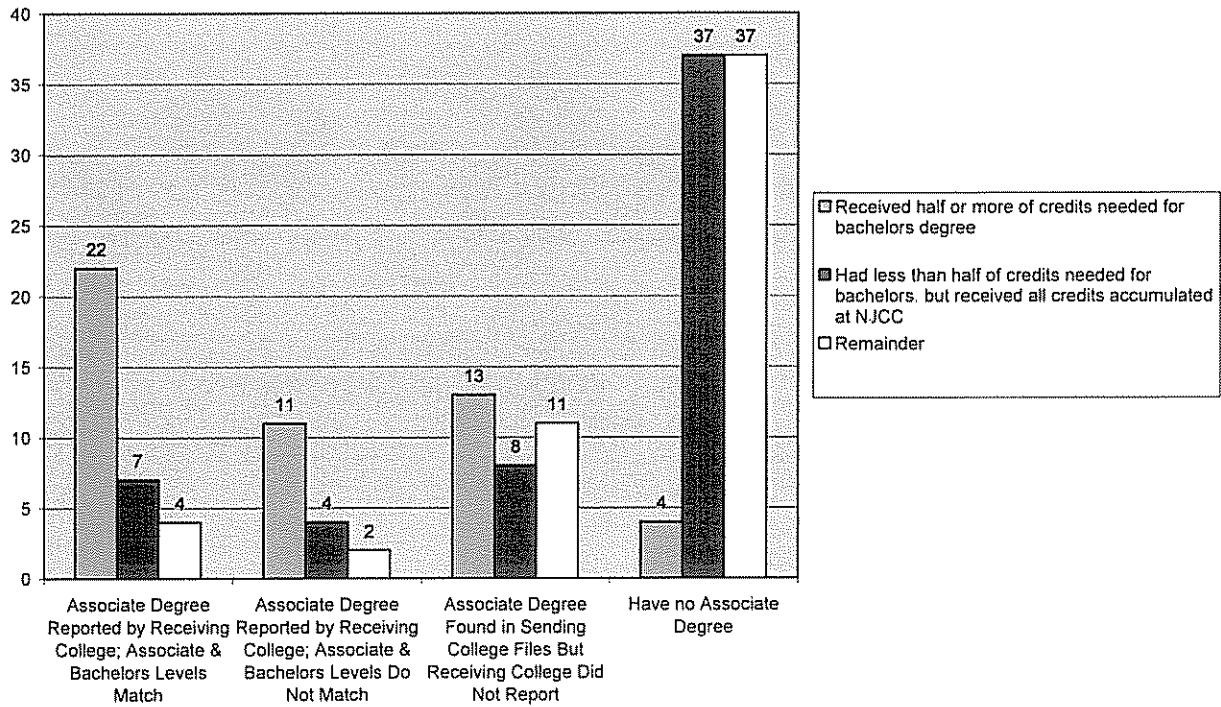

COMPREHENSIVE STATE-WIDE TRANSFER AGREEMENT:

STUDENT APPEAL PROCESS

This process applies only to students transferring to The College of New Jersey who have completed Associates in Arts (AA) or Associates in Science (AS) degrees from New Jersey public community colleges. The agreement makes it possible for students with AA and AS degrees to transfer into TCNJ with their first two years complete, including all liberal learning (general education) requirements, except when specific courses for major requirements, prerequisites, certification, or accreditation are not included among those completed at the community college. The entire agreement can be found at the link below.

Students wishing to appeal decisions about transfer of credits believed not to be consistent with the agreement must do so in writing within 30 days of receiving the evaluation of transfer credit using one of the forms linked below. This appeal must be addressed to the Director of Records and Registration, who will convene a committee consisting of representatives from the offices of Academic Affairs, Liberal Learning, and Records and Registration. That committee will render a decision with a rationale within 60 days of the receipt of the appeal. The decision of the College is final. The relevant community college will be informed of the nature of the appeal and the College's decision.

November 2008

View the full agreement here:

[Comprehensive Statewide Transfer Agreement](#)

Download the appeal form here:

[Transfer Appeals Form 2-2 \(PDF\)](#)

[Transfer Appeals Form 2-2 \(Word Document\)](#)

Thomas Edison State College (TESC)

Founded in 1972, Thomas Edison State College is the state college in New Jersey where students earn credit through a variety of methods designed exclusively for adult learners, including online courses, guided independent study, examination programs, transferring credits earned from other regionally accredited institutions, earning credit for professional and/or military training, and by demonstrating college-level knowledge acquired outside a traditional classroom. It is located in Trenton in Mercer County.

Thomas Edison State College offers 15 bachelor's degree programs.

Undergraduate enrollment for fall 2007 was 15,963 students; all were reported as part-time students.

The racial composition of the undergraduate population in fall 2007 was 59.1% White; 15.0% Black; 7.3% Hispanic; 2.4% Asian; 1.0% American Indian; 1.3% Alien; and 13.9% Unknown.

The table below shows five years of undergraduate fall enrollment.

<u>Year</u>	<u>2003</u>	<u>2004</u>	<u>2005</u>	<u>2006</u>	<u>2007</u>	<u>2008</u>
Undergraduate Total	10,011	10,750	10,906	12,733	15,963	n/a



101 W. State St.
Trenton, NJ 08608-1176
www.tesc.edu

RECEIVED

NOV 26 2008

COMMISSION ON
HIGHER EDUCATION

Division of Planning
and Research
(609) 984-1151
Fax: (609) 292-9000

November 19, 2008

Ms. Jane Oates
Executive Director
Commission on Higher Education
P.O. Box 542
Trenton, NJ 08625-0562

Re: Comprehensive State-Wide Transfer Agreement

Dear Ms. Oates:

Your letter to Dr. Pruitt, dated November 18, 2008, was forwarded to my office for review and response. The College has always submitted its federal, state, and regional reports and data files in a timely manner. Given the College's mission and the students that it serves, there are occasions when the data being requested are not applicable to our student body and/or the variables used don't mean the same thing in our institution as they do at other institutions; in those cases, the College makes a decision not to submit a survey or data file.

Since Thomas Edison State College does not have a traditional "transfer student" status, a decision was made not to complete the New Transfer Student data file. The College does not have a transfer application; our institution evaluates credits from other institutions and then assesses whether those credits can be used toward the student's degree. The focus is on the individual course credits transferred, not the transfer status of the students.

This issue was discussed in a March 2007 meeting that focused on the Registration Status variable in the Enrollment Data File. This meeting included Betsy Garatti, Gary Nigh, Penelope Brouwer and me. Prior to this meeting, all Thomas Edison State College students were classified as "Transfer Students," not because of their traditional "transfer student" status but because they "...bring or seek to bring college credits from another institution." A decision was made to separate our new students (e.g., new to the College) from our continuing students. It was understood that the transfer category was the best category to capture our "new" students because they bring in college credits from other institutions.

Given the current purpose for which the New Transfer Student file is being used, we will be working with our student record system to ensure that we can provide the necessary data. As time does not permit us to get the data file ready for this year's deadline, we plan to participate in this survey next year.

Sincerely,

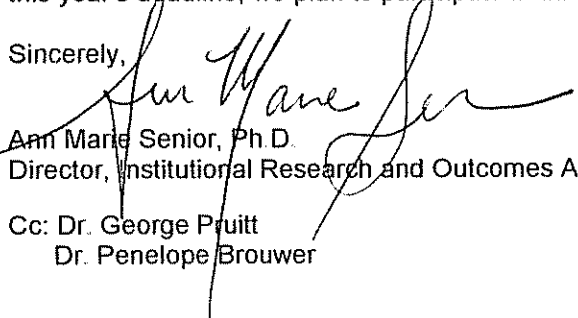
Ann Marie Senior, Ph.D.
Director, Institutional Research and Outcomes Assessment

Cc: Dr. George Pruitt
Dr. Penelope Brouwer

New Jersey Statewide Transfer and Articulation Agreement Appeals Process

Thomas Edison State College has implemented the New Jersey Statewide Transfer and Articulation Agreement policies as a transfer resource to support course transfer decisions made by the College. The College provides an appeal process for students to request reconsideration of these policies. This appeal process will be announced on the College's website at www.tesc.edu and in the following College publications; *Undergraduate Catalog, Student Handbook and Degree Planning Handbooks*. Questions regarding the appeal process can be forwarded to the Office of the Registrar by phone at 609-984-1180 or by email at registrar@tesc.edu

Procedures and Appeal Guidelines

Review Procedures

Undergraduate student's who disagree with any portion of their transfer credit evaluation should submit a written request for review to the Registrar by mail to Office of the Registrar, Thomas Edison State College 101 W. State Street Trenton, New Jersey 08008-1176 or by e-mail to registrar@tesc.edu. Students have 30 calendar days from receipt of the academic evaluation to file an appeal.

The request for review should include the following information:

- Your full name
- Thomas Edison State College student ID number
- Mailing address and phone number
- Email address
- Detailed narrative to include supporting rationale and reason for appeal
- Documentation which supports the request. This could include course descriptions, course syllabus, course objectives, learning outcomes, transcripts or other relevant information

Thomas Edison State College's Registrar will conduct a review of the credit evaluation and respond to the student in writing with a decision.

Formal Appeals

Undergraduate students not satisfied with the Registrar's determination or who believe that the decision is not consistent with the Statewide Transfer and Articulation Agreement may appeal in writing to the Vice Provost for Learner Services within 30 calendar days of receipt of the decision of the Registrar. The appeal should contain the same information required for the Registrar's Review (see above) along with any additional explanations or arguments the student wishes to have considered. The Vice Provost for Learner Services will refer the matter to either the Student Appeals or appropriate Academic Appeals Committee. The Committee will meet to consider the appeal within 30 calendar days of receipt. The Committee may affirm, reject, modify, or adjust the transfer credit evaluation as they deem appropriate. The Committee will inform the student, in writing, of its decision. The Chairperson of the Committee shall also inform the Provost of their decision.

The decision of the Committee is final and may not be appealed within the institution.

University of Medicine & Dentistry of New Jersey (UMDNJ)

Founded in 1970 as the College of Medicine and Dentistry of New Jersey, the University of Medicine and Dentistry of New Jersey is a public research health sciences institution encompassing the medical, dental, allied health, nursing, public health and biomedical sciences disciplines. Its main campus is in Newark in Essex County. It has four additional major campuses in Camden, New Brunswick, Piscataway and Stratford.

The University of Medicine and Dentistry of New Jersey offers twelve bachelor's degree programs.

Undergraduate enrollment in fall 2007 was 900 students: 543 full-time and 357 part-time.

The racial composition of the undergraduate population in fall 2007 was 44.0% White; 18.9% Black; 9.2% Hispanic; 14.1% Asian; 0.1% American Indian; 2.8% Alien; and 10.9% Unknown.

The table below shows five years of undergraduate fall enrollment.

<u>Year</u>	<u>2003</u>	<u>2004</u>	<u>2005</u>	<u>2006</u>	<u>2007</u>	<u>2008</u>
Undergraduate Total	772	896	994	846	900	n/a



Graduate School of Biomedical Sciences
New Jersey Dental School
New Jersey Medical School
Robert Wood Johnson Medical School
School of Health Related Professions
School of Nursing
School of Osteopathic Medicine
School of Public Health

DENISE V. RODGERS, M.D.
Executive Vice President
for Academic and Clinical Affairs

November 21, 2008

Jane Oates
Executive Director
State of New Jersey
Commission on Higher Education
P.O. Box 542
Trenton, NJ 08625-0562

Dear Ms. Oates,

Thank you for your letter of November 18, 2008 regarding the Comprehensive State-Wide Transfer Agreement. I appreciate the opportunity to explain the data submission from UMDNJ.

UMDNJ did not submit a transfer file to SURE, as this new requirement was indicated as applying only to "senior public institutions" into which undergraduates can transfer from a community college. UMDNJ is classified as a "public research institution," not a "senior public institution." In addition, our undergraduate degree programs are either jointly given with a New Jersey college OR are "second bachelor's" degrees. In neither case are the students a "transfer" from a community college to a senior college.

The SURE system affords us only two ways of identifying students: as "new" or as "transfer". Neither of these designations accurately describes the joint program student moving from one phase of the program to another, or to the student already holding a bachelor's degree undertaking a course of study towards a second bachelor's degree.

The Fall Enrollment file indicates transfer students only because the reporting mechanism provided does not include an alternate status for our joint program or second bachelor's students that accurately describes them. Since these students are not transferring into UMDNJ, they were not included in a SURE transfer file.

Please be assured that UMDNJ would be happy to discuss these issues with the Commission, and to work with your staff to either develop an alternate category that will fulfill your requirements or to provide additional information concerning prior educational experiences of our students.

Thank you very much.

Yours truly,

Denise Rodgers (JAE)

Denise V. Rodgers, M.D.
Executive Vice President for
Academic and Clinical Affairs

William Paterson University (WPU)

Founded in 1855, William Paterson University began as a normal school. It is now a comprehensive institution with programs in the liberal arts and sciences, education, business, health professions, communication and the arts. It is located in Wayne in Passaic County.

WPU offers 45 bachelor's degree programs.

Undergraduate enrollment in fall 2007 was 8,830 students: 7,321 full-time and 1,509 part-time.

The racial composition of the undergraduate population in fall 2007 was 55.1% White; 13.6% Black; 17.0% Hispanic; 5.9% Asian; 0.2% American Indian; 0.8% Alien; and 7.5% Unknown.

The table below shows five years of undergraduate fall enrollment.

Year	2003	2004	2005	2006	2007	2008
Undergraduate Total	9,302	9,418	9,110	8,862	8,830	n/a

The table below shows six years of new undergraduate transfer fall enrollment.

Year	2003	2004	2005	2006	2007	2008
Transfer Total	986	967	822	730	902	863

New Undergraduate Transfers Received by William Paterson University in Fall 2008

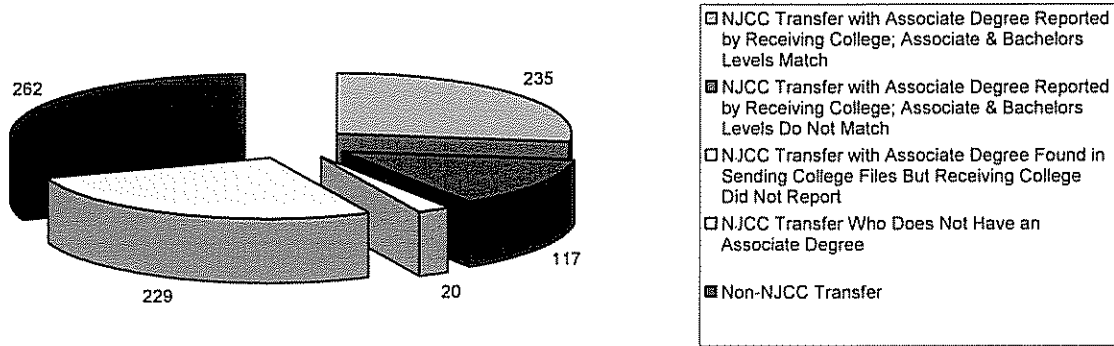

New Undergraduate Transfers from NJ Community Colleges to William Paterson University, Fall 2008

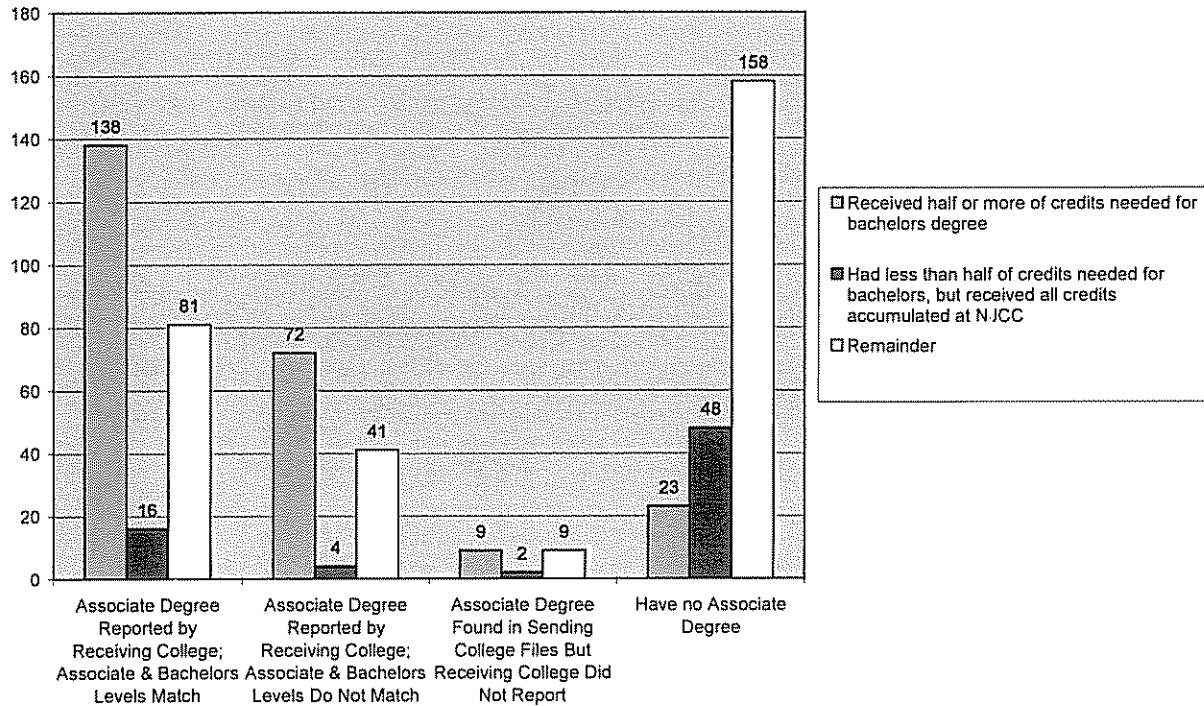

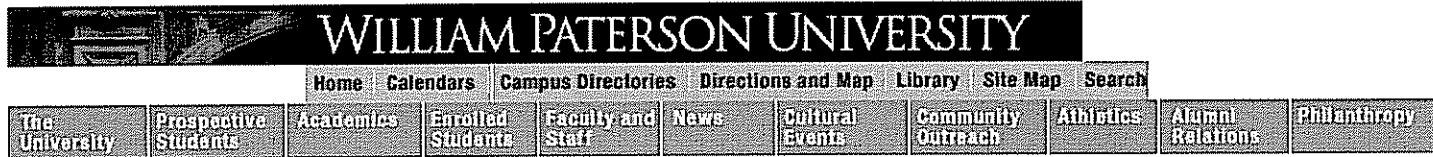

New Jersey Statewide Transfer Agreement Appeals Process

This process addresses the concern of students holding A.A. or A.S. degrees who feel that they have not received an accurate and complete transfer evaluation under the terms of the New Jersey Statewide Transfer Agreement (<http://www.state.nj.us/highereducation/PDFs/XferAgreementOct08.pdf>). Appeals must be filed within thirty (30) days of the students' receipt of the evaluation. The University will respond to request additional information, if needed, within fifteen (15) business days. Appeals decisions will be communicated to the student's WPUNJ.edu email address within sixty days of posting, whether, additional material has been provided or not.

All appeals must be submitted electronically (by email) to the Transfer Appeal Coordinator at njtransferappeals@wpunj.edu

The appeal should contain the following information:

Name of student (full name)

WPUNJ.edu e-mail address*

WPUNJ Student Number (855 number)

Name of Community/County College Attended

Statement of not more than 250 words of the basis of the appeal

(*Because different students may have the same name, additional identifying features may be used in the address to distinguish between individuals. Be sure to supply your full WPUNJ e-mail address. WPUNJ e-mail is an official means of communication for University business.)

[[Back to Undergraduate Admissions](#)]

Considerations for Future Reports

The Commission has fulfilled the statutory requirement of completing this report. While some Institutional Research Directors suggested that the information be reported only in the aggregate, the Commission felt that individual college data was expected by the legislature. In making that decision, the Commission has identified several difficulties to be addressed in the future.

- **Timing:** Several institutions felt that they lacked sufficient time to work with their admissions staff to identify and correct data anomalies regarding student status. To prepare the required information demands that admissions, academic and research staff share information which may present different challenges at each college. Other institutional policies may delay the transmission of information regarding students.
- **Additional information:** As the college teams were preparing the data, they expressed concern that there was no collection of data on the reasons that the senior public colleges were unable to accept credits.
- **Transcript issues:** Students are responsible for requesting that the final transcripts be sent to the college which they will attend. As students begin the transfer process they have their transcript sent to a variety of colleges, but they must request a final transcript be sent to their intended senior college. It is imperative that the receiving institution have the final transcript as early as possible to ensure the best outcome for the student.
- **Improved communications:** Both community colleges and the senior public colleges and universities need to improve the understanding of specialized degree program requirements. A transferring student needs to have a clear understanding that certain courses will be accepted in the school of arts and sciences but that more targeted courses are required to transfer into business or engineering majors. This clarification is critical if we hope to maintain students in their desired majors without unnecessary course duplication.

Conclusion

The development and analyses of these initial data are meant to expand the understanding of the implementation of the transfer legislation and specifically the implementation of the Comprehensive State-wide Transfer Agreement. The Presidents' Council Transfer Committee and each of the colleges have worked earnestly with the Commission during this first year to examine policies that impact students transferring from community colleges to senior public colleges and universities.

The information gathered will influence the form and content of next year's report, the institutional procedures for data collection and submission, as well as institutional policies regarding the transfer process. Already we have learned many lessons.

Having only one year of data does not allow us to suggest trends or identify environmental conditions (such as economic influences, program specific influence, etc.) yet. The data does

suggest areas that warrant increased attention. For example, do transfers at any institution have different outcomes than students who began their academic career at that institution? Are there policies at the sending institution or the receiving institution that could be changed to improve student outcomes? How will general education courses be monitored and changed as necessary?

The goal of the legislation was to ensure an efficient transfer of credits for students who begin their education at a community college and are accepted to a senior public college to continue toward their baccalaureate degree. The purpose of the Transfer of Credit Annual Report was to provide a picture of the progress in this area. The Commission anticipates that there will be suggestions on how to improve the information collected and the reporting process. We welcome suggestions on proposed changes to the annual report from all interested parties – colleges, legislators, and, most importantly, students. The Commission will continue to work with the Presidents' Council to ensure that students experience a transfer process that facilitates rather than impedes their academic progress.