

LOAD TESTS OF ARMORED BRIDGE JOINTS

BRUCE COSABOOM, AUTHOR

GEORGE KOZLOV, PROJECT ENGINEER

RESEARCH CONDUCTED BY

DIVISION OF RESEARCH AND DEVELOPMENT

NEW JERSEY STATE DEPARTMENT OF TRANSPORTATION

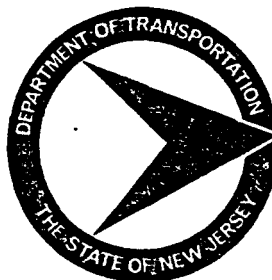

IN COOPERATION WITH
U.S. DEPARTMENT OF TRANSPORTATION
FEDERAL HIGHWAY ADMINISTRATION

SUPPLEMENT III TO THE FINAL REPORT "PREFORMED
ELASTOMERIC SEALERS FOR BRIDGES ... PHASE I"

NOVEMBER, 1975

1. Report No.	2. Government Accession No. PB260876/AS	3. Recipient's Catalog No.	
4. Title and Subtitle "Load Tests of Armored Bridge Joints" (Supplement III)		5. Report Date	6. Performing Organization Code
7. Author(s) Bruce Cosaboom, Principal Engineer, Research George Kozlov, Project Engineer		8. Performing Organization Report No.	
9. Performing Organization Name and Address Bureau of Structures and Materials Division of Research and Development New Jersey Department of Transportation 1035 Parkway Ave., Trenton, N. J. 08625		10. Work Unit No.	11. Contract or Grant No.
12. Sponsoring Agency Name and Address Federal Highway Administration Washington, D. C.		13. Type of Report and Period Covered	
15. Supplementary Notes This report is a supplement to a final report titled, "Preformed Elastomeric Joint Sealers for Bridges ... Phase I."		14. Sponsoring Agency Code	
16. Abstract <p>Two armored expansion joints for bridges are analyzed with respect to their stress behavior under static loading. Details of the static load tests and attempts at dynamic load tests are provided. Although the tests described herein are very limited, significant information is provided regarding design loads, flexural rigidity of the armored joint system, method and spacing of anchorage, and geometry of the armament.</p>			
17. Key Words Armored expansion joint, load distribution, load magnitude, anchorage bars, system rigidity, strain, stress, repeatability		18. Distribution Statement	
19. Security Classif. (of this report)	20. Security Classif. (of this page)	21. No. of Pages	22. Price

"The contents of this report reflect the views of the author(s) who is (are) responsible for the facts and the accuracy of the data presented herein. The contents do not necessarily reflect the official views or policies of the (State or the) Federal Highway Administration. This report does not constitute a standard, specification, or regulation."

TABLE OF CONTENTS

	Page
I. Introduction	1
II. Klockner Road Armored Joint	2
A. Instrumentation	2
1. Strain Measuring.	2
2. Loading	6
B. Data Analysis	7
1. General Comments.	7
2. Concentrated Loads.	12
3. Distributed Loads	19
4. Discussion of Loadings.	22
5. Discussion of the Data.	26
III. Cypress Lane Armored Joint.	30
A. Instrumentation	30
B. Data Analysis	30
IV. Conclusions	37

LIST OF FIGURES

	Page
1. Plan View of Klockner Road Bridge.	3
2. Cross-Section of Klockner Road Armament.	4
3. Gage Locations and Foam Placement (Klockner Road).	5
4. Loading of the Armored Joint	8
5. Klockner Road Test Results - Concentrated Load	10
6. Klockner Road Test Results - Distributed Load.	11
7. Typical Haunch-Support for Cypress Lane Armored Joint.	31
8. Anchorage for Cypress Lane Armored Joint	32

LIST OF TABLES

	Page
Table 1 - Strains from Cypress Lane Tests.	33

I. Introduction

This report describes the instrumentation and load testing of two different armored expansion joints. The purpose of the tests was to shed light on factors relating to the design of armored joints, and more specifically, to determine whether either of the two subject joints was underdesigned or overdesigned. No such tests were planned as part of the overall research. Hence, the author was forced to conduct this portion of the research under severe limitations and the results and conclusions are presented in that light.

One armored joint, hereinafter referred to as the Klockner Road joint, was fabricated and installed according to the design and installation methods proposed by the Division of Research and Development. (Complete details are provided in the main final report, "Preformed Elastomeric Joint Sealers for Bridges . . . Phase I.) The joint is located over the center pier of the Klockner Road Bridge, I-295, Section 7D and 8A and provided a comparison of actual structural behavior with the theoretically predicted behavior. Of the two joints, this one is the only one for which the design rationale is known. For this reason the report focuses mainly upon the Klockner Road joint.

Because no design information regarding the second armored joint was provided, the author could not intelligently select critical locations for strain gages. And because of the funding limitations, the author could not afford to install numerous gages on the joint. Therefore, discussion of this joint, located at the center pier of the Cypress Lane Bridge and hereinafter referred to as the Cypress Lane joint, is restricted to some very limited, but significant commentary and analysis.

II. Klockner Road Armored Joint

A. Instrumentation

1. Strain Measuring - Figure 1 is a plan view of the Klockner Road Bridge, in which is shown the location of the experimental armored joint and the instrumented section. Figure 2 shows a cross-section of one side of that armored joint. The anchorage bars shown were used throughout the length of the joint with modification of four adjacent bottom bars at one location. Figure 3 shows the modification to those bottom bars, as well as the locations of strain gages, and the placement of foam rubber. The foam rubber extended several feet beyond this instrumented area to duplicate the "worst case" assumption utilized in the joint's design. This assumption was that, through one means or another, the armament may eventually lose support by the deck concrete that interfaced with the armament. In such a case, the armament would "float" on its anchorage bars alone, thereby transmitting full load directly into those bars.

The modification to the 4 bottom bars was implemented for the purpose of determining the magnitude of vertical load that the bottom bars receive. Hence, load is transferred from the armor to the bottom bars via the $3/4 \times 3/4$ inch load-transfer bars. Such loads were indirectly measured by use of strain gages mounted on the load transfer bars. Bending and axial strains were also directly measured in the two top anchorage bars that fastened to the armament in the same 1-foot section as the modified bottom bars. Since the anchorage bar spacing pattern repeated every foot throughout the length of the joint, the instrumentation of each bar within a one foot section provided information that is considered generally representative of

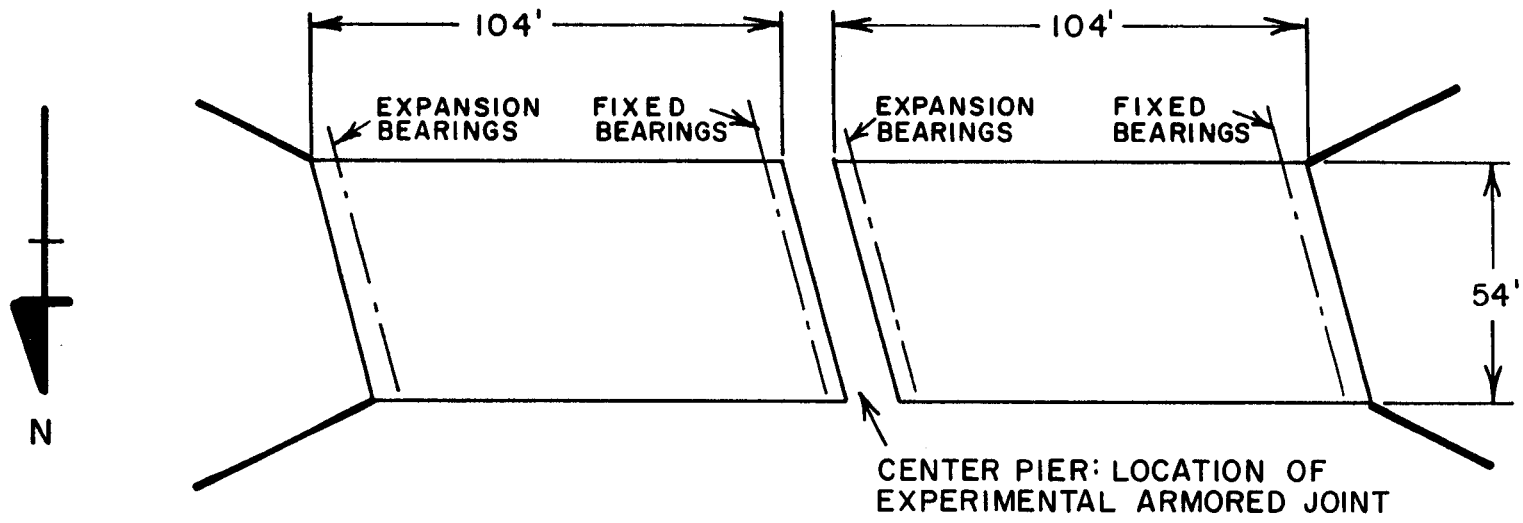

FIGURE 1

LOCATION OF EXPERIMENTAL ARMORED JOINT AND
LAYOUT OF KLOCKNER ROAD BRIDGE

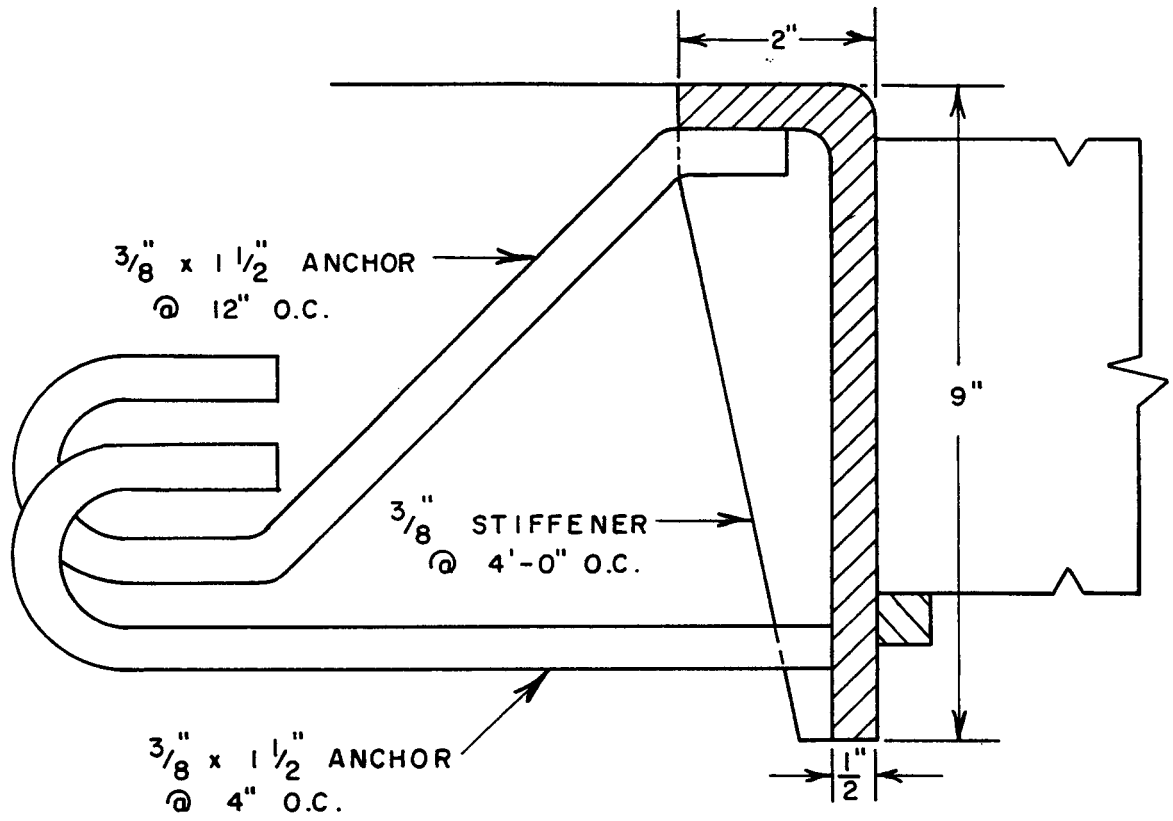

FIGURE 2

CROSS-SECTION OF KLOCKNER
ROAD ARMAMENT

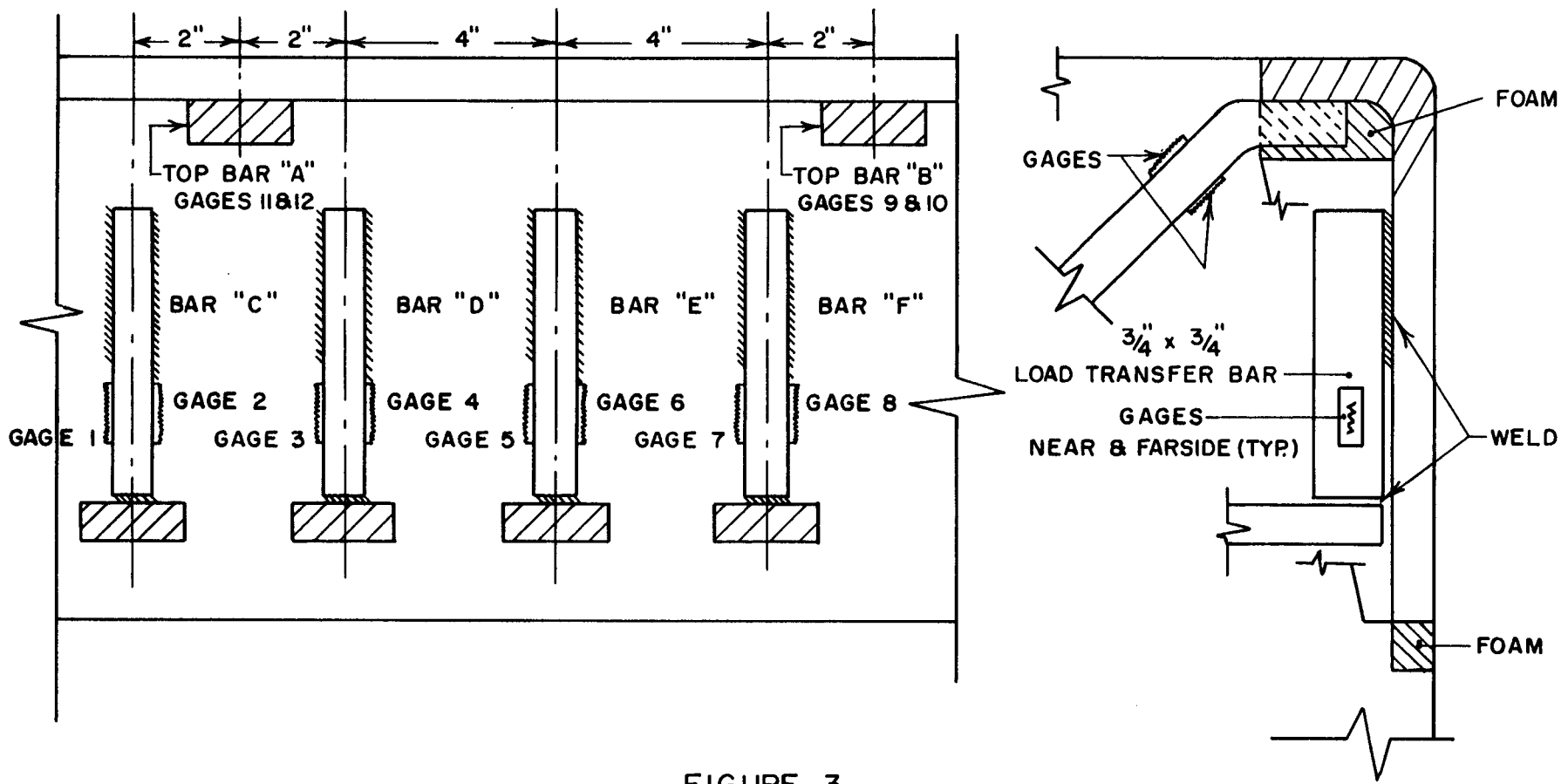

FIGURE 3
GAGE LOCATIONS & FOAM PLACEMENT

any other 1-foot portion of the joint.

The strain gages used are electrical resistance type gages that, when used under laboratory conditions, will measure strains of as little as a few micro-inches per inch. (One micro-inch = 1u-inch = one millionth of an inch.) There are several factors, which will be discussed later, that influence and reduce overall accuracy of strain readings under field conditions. The strain gages were selected on the basis of their ability to provide both dynamic and static strains, but primarily on the basis of physical size requirements and a severely limited budget. Three different pieces of strain indicating equipment were laboratory tested and calibrated for use in reading the strain gages; only two were used during field tests.

For measurement of static strains, a Baldwin strain indicator was used. This device, though very old, provided continuously reliable readings during the field tests. In general, the device operates on the principles of wheatstone bridge circuitry with a highly sensitive galvanometer capable of detecting extremely small circuit imbalances due to resistance changes. The Division of Research is very fortunate and thankful that they could borrow the indicator from the Department of Civil and Environmental Engineering of Rutgers University. It was found that none of the Division's equipment could provide strain data with comparable accuracy. For measurement of dynamic strains, a strip-chart Visi-corder was used. No further description of this equipment is warranted since field tests yielded no measurable dynamic strains.

2. Loading - As it happened, loading was a major problem, not because of cost limitations, but because of impracticality. The

virtual impossibility of the armament ever incurring the actual design loads will be discussed in the analysis. The methods of loading as hereinafter described were selected essentially because they were the largest loadings achievable with existing means. The load vehicle was the largest tandem-axle dump truck owned by the Department. The truck was fully loaded. The tandem-axles carried well in excess of 30 tons. For dynamic loading, the truck was driven across the armored joint at 15-20 mph. For static loads, the walking-beam axle was positioned above the load point and the truck was hydraulically raised from the deck. Three different size load distribution plates were successively placed beneath the jack. Figure 4A shows the plates, with the largest in an inverted position. A 4-inch plate was used to provide a "point" loading. One-foot and 2-foot long plates were used to provide line-load distribution. The load magnitude was accurately controlled by a calibrated pressure gage installed in-line with the hydraulic jacking equipment. (Figure 4B) Strains were measured under a "full load" of 28,000 pounds. Notice from Figure 4C that the load was applied entirely to the armament only and not onto the concrete, or the other side of the joint.

B. Data Analysis

1. General

Before getting into the analysis, a few statements will serve to set the format for the analysis. Overall, the data probably raises more questions than it answers. These load tests were never planned as part of any research. The magnitude of this testing phase was absolutely minimal since there simply was no money available to do the

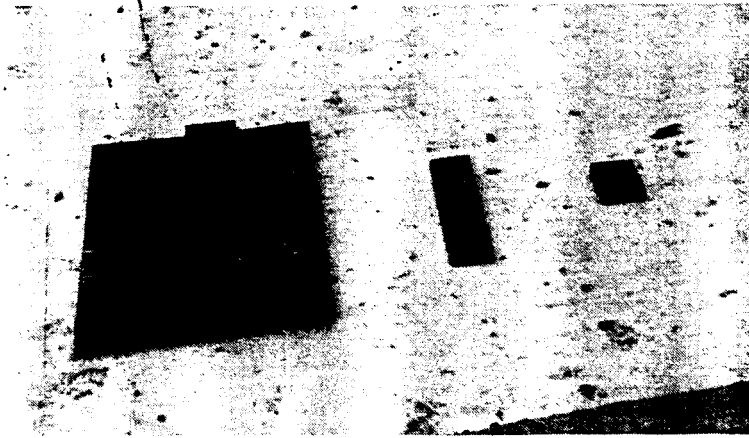

FIGURE 4A
LOAD DISTRIBUTION
PLATES

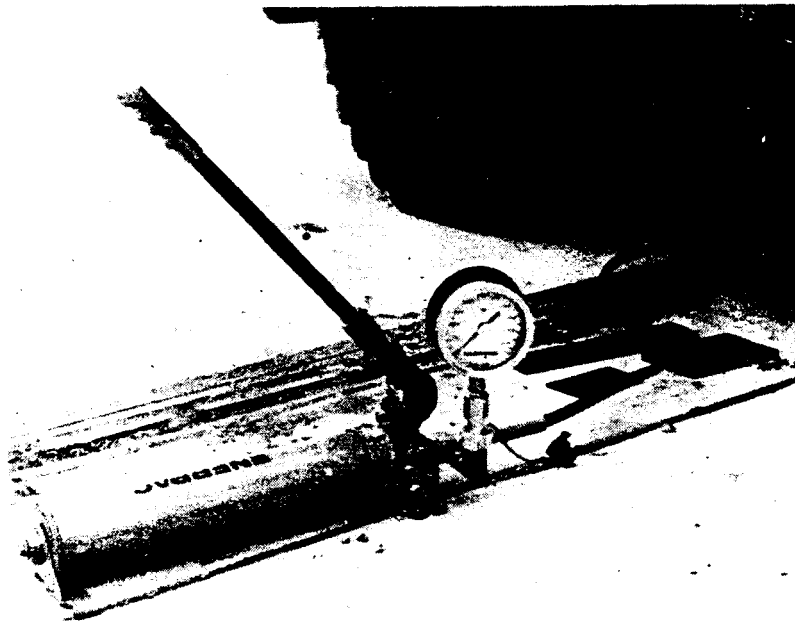

FIGURE 4B
HYDRAULIC LOADING
EQUIPMENT WITH
PRESSURE GAGE

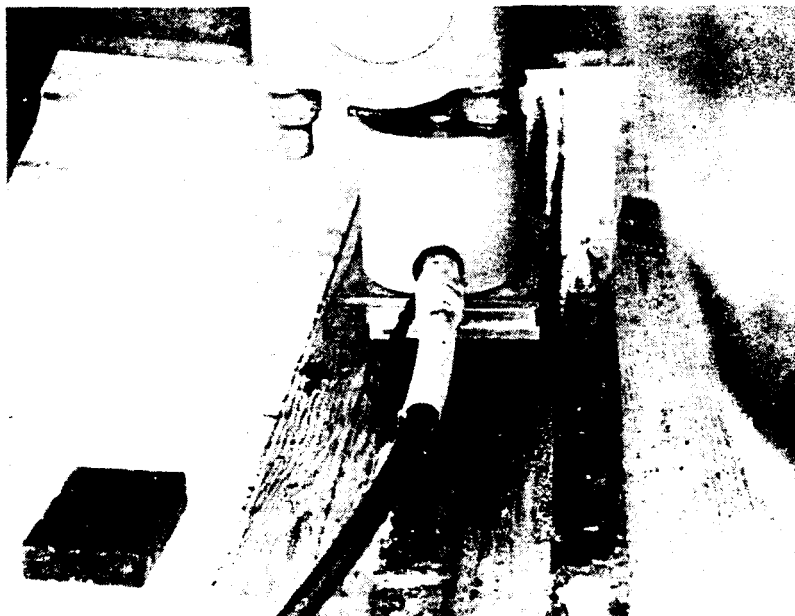
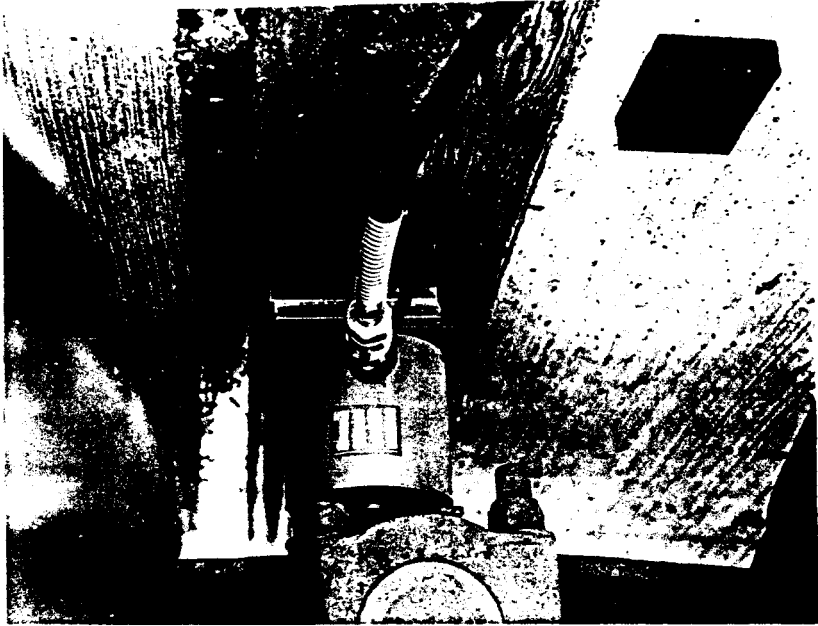
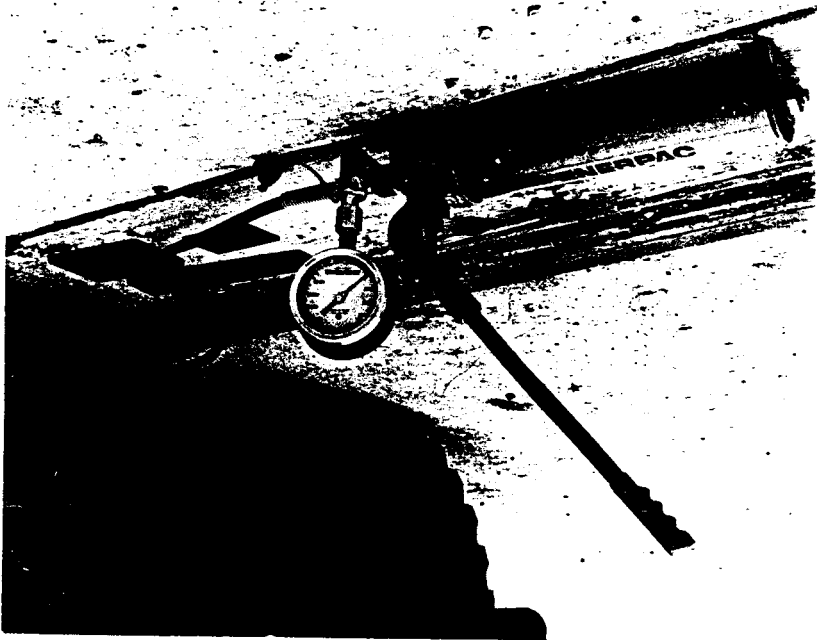

FIGURE 4C
HYDRAULIC JACK
IN POSITION
ATOP ARMAMENT

4h



4z



4+

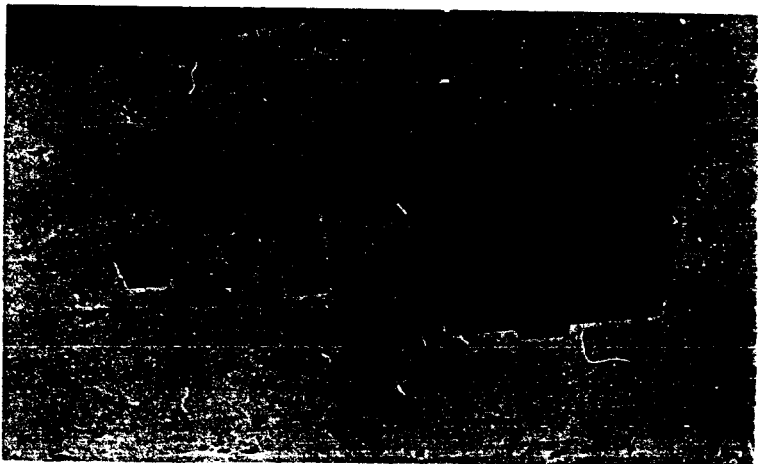

Hydraulic Jack

job in a more detailed manner. As it was, available funds were spent entirely on the electric strain gages and their installations; all other equipment was borrowed. Hence, as it will be seen, the results of this work are very sketchy. Some trends and generalities evolve, providing more in the way of indications than facts.

Figures 5 and 6 present the data from Klockner Road static load tests. In these figures, plots A and B represent the measured axial load in each of the two instrumented top bars. Plots C, D, E, and F show the strains measured in each of the 4 load-transfer bars. Review of Figure 3 shows that these 6 plots have been arranged such that they are in the same positions, relative to each other, as the strain gages are actually mounted on the structure. This is to assist the reader in understanding where the data was measured. Results shown in Figure 5 are from the 4-inch loading plate. Results in Figure 6 are from the 12-inch load distribution plate. What few data were taken using the 24-inch distribution plate appears as "*" denotations in the plots of Figure 6.

All of the plots are fashioned after the concept of influence lines in that they plot the strain or load in a particular member as the loading point moves to different positions atop the joint. The arrow drawn on the abscissa indicates the location of the load-carrying member in which the indicated strains or loads were measured. The footage indicated along the abscissa always uses the same reference point as the origin, i.e., the top anchorage bar on which gages #11 and #12 are mounted.

To begin the discussion, it should be realized that one of the primary concerns was the magnitude of the vertical load transmitted

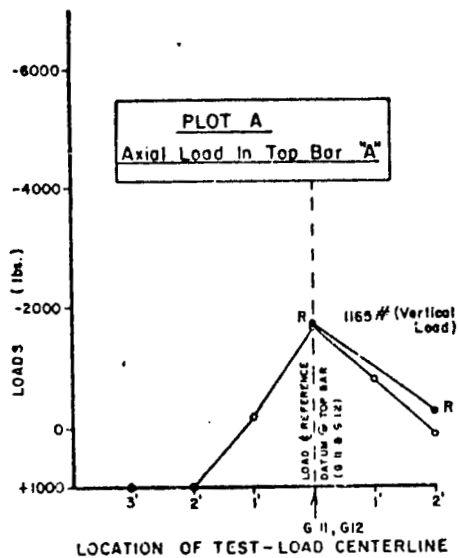
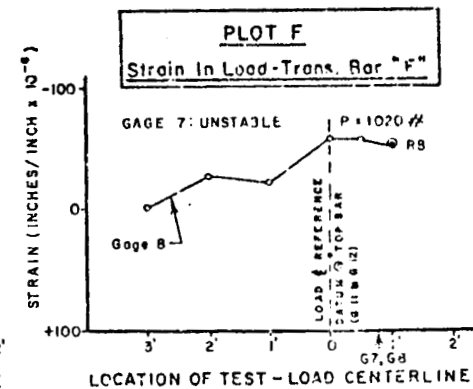
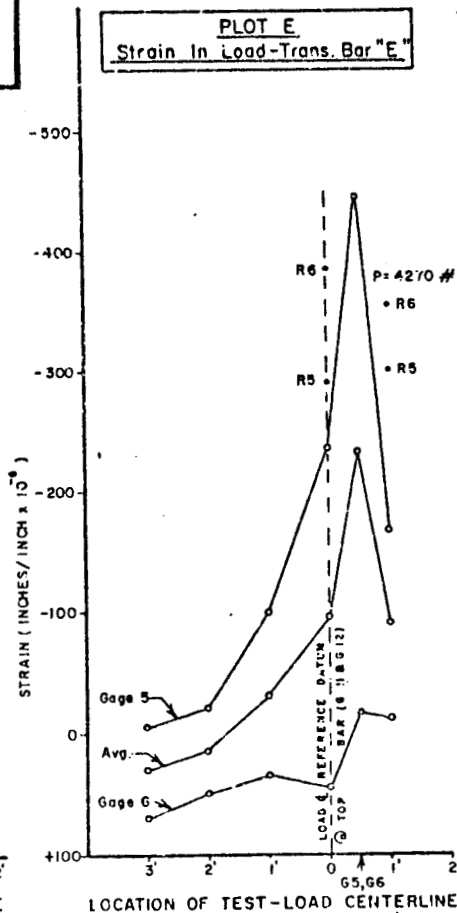
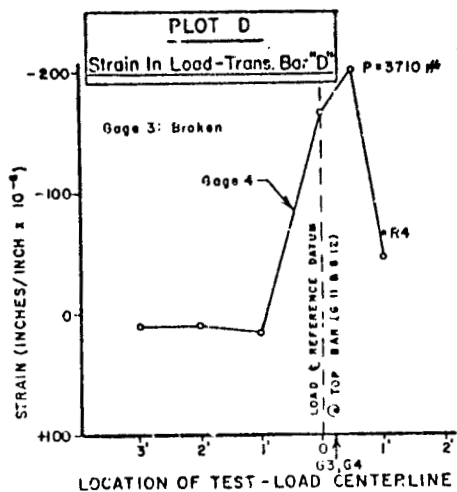
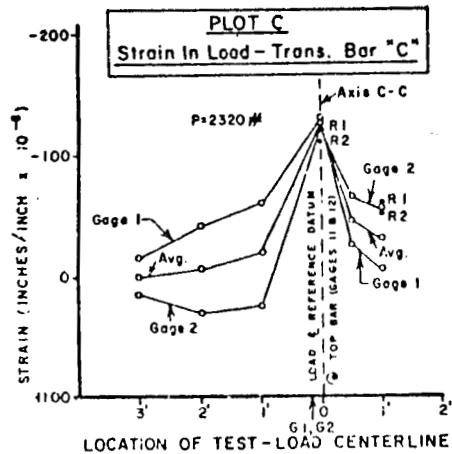
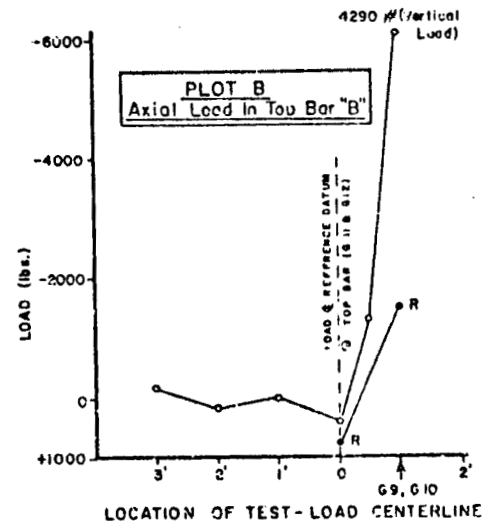

FIGURE 5
KLOCKNER ROAD TEST RESULTS

A & D = TOP BAR AXIAL LOADS vs. TEST LOAD POSITION
C, D, E & F: STRAINS IN BOTTOM LOAD-TRANSFER BARS vs. TEST LOAD POSITION

NOTES:

- 1) SIGN CONVENTION (ALL PLOTS):
TENSION = PLUS
COMPRESSION = MINUS
- 2) ALL RESULTS ARE FOR 4" LOAD DISTRIBUTION (CONCENTRATED LOAD)
- 3) "R" INDICATES A REPEATABILITY CHECK



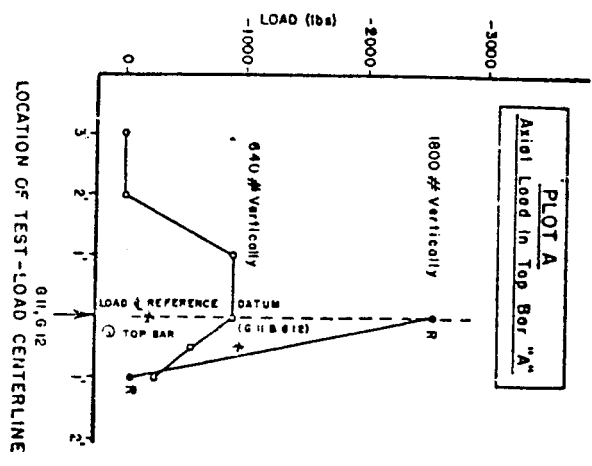
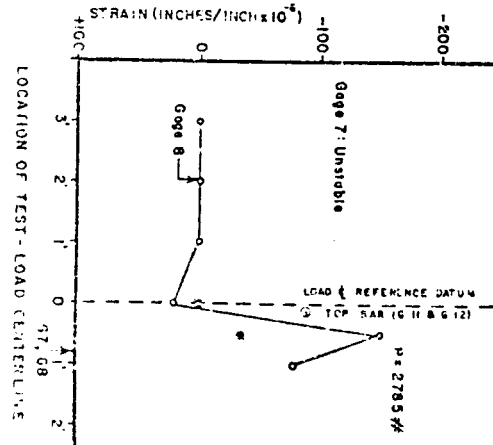
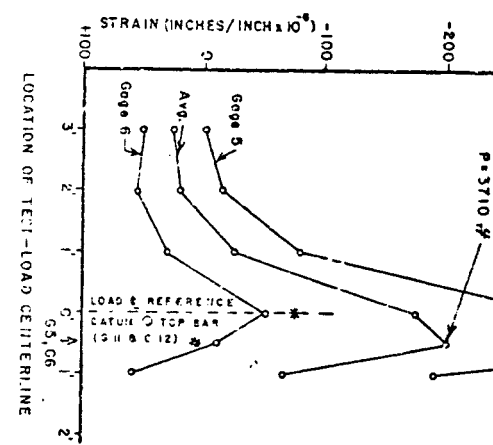
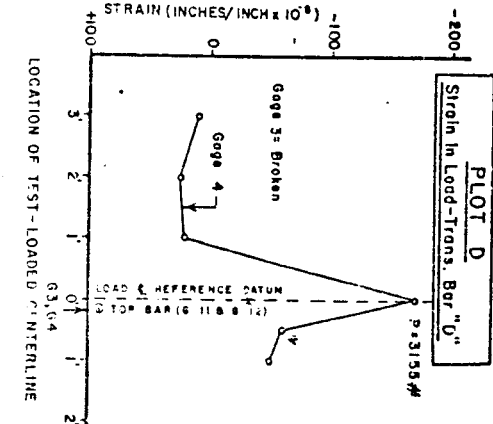
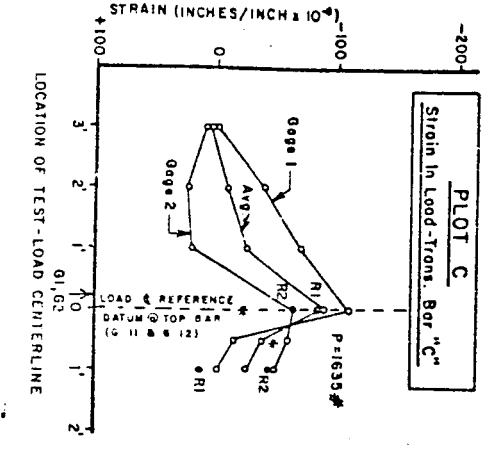
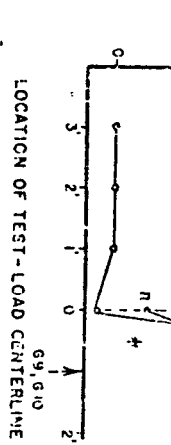
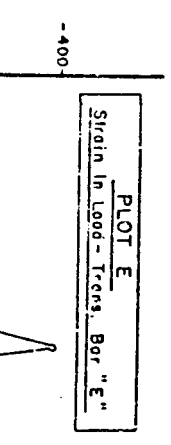



FIGURE 6
KLOCKNER ROAD TEST RESULTS

A, B : TOP BAR AXIAL LOADS VS. TEST LOAD POSITION
C, D, E & F : STRAIN IN BOTTOM LOAD-TRANSFER BARS VS. TEST LOAD POSITION

NOTES:
1) SIGN CONVENTION (ALL PLOTS):
TENSION = PLUS
COMPRESSION = MINUS
2) ALL RESULTS ARE FOR 12" LOAD DISTRIBUTION UNLESS OTHERWISE STATED.
3) "R" INDICATES A REPEATABILITY CHECK
4) "*" INDICATES 24" BASE PLATE TEST





into the bottom anchorage bars. Plots C through F provide this information since they are plots of strains that were measured in the vertical axis of the load-transfer bars. In plot C are shown the separate results of gage #1 and gage #2. Gages were mounted on opposite sides of the bars. Hence, bending stresses as well as axial stresses are measured. The heavy line connecting the circles is the average of the two gages. It represents the average axial load taken by the load transfer bar. Plot E is much the same as plot C, but it represents gages #5 and #6. Plot D shows the results of gage #4; gage #3 was apparently destroyed after its installation. Therefore, the average axial load in that load-transfer bar cannot be determined with accuracy. Plot F again shows only one gage (#8). Its mate, i.e., gage #7, was inoperational during the tests. Furthermore, gage #8 exhibited a constantly drifting "zero" point. This made it difficult to obtain accurate strains in this load-transfer bar.

2. Concentrated Loads

Referring to Figure 5C, it is seen that when the concentrated load is almost directly above bar C the strain magnitude is largest. Of course, this is expected. Notice how the strain drops off rapidly as the load moves to one side or the other of this bar. There is also a slight lack of symmetry of the average strain curve about vertical axis C-C. Ideally, there should be almost perfect symmetry, but it is clear that the strains in Bar C are higher as the load moves to the right, than when the load moves to the left of Bar C. This indicates that the load-transfer bars are supporting slightly less load than the regular anchorage bars. (This indication will be confirmed later in the discussion.) Notice also that the bending

stresses reverse as the load moves across bar C, a perfectly normal phenomenon since deflection of the armament would induce a bi-axial bending moment in load-transfer bars. At a distance of about 2 feet from bar C, the axial strain has nearly dropped to zero, although there is still some bending stress exhibited. It is pointed out that bending stress in the load transfer bars can also be caused by non-uniform support beneath the bottom anchorage bar. This would give a twisting condition in the anchor and consequently a bending stress in a transfer bar. While little, if any, of the bending shown in plot C is probably due to such a condition, Figure 5E may be a good example of it.

Figure 5E represents the strains in bar E as the concentrated load moved to various positions. Considering only the average strain curve (axial load), the data spell out a rather logical performance. First, the maximum axial strain occurs when the load is directly above bar E and it is significantly larger than in bar C which is explained by the fact that bar E is centered between two top anchors, whereas bar C is only 2 inches from a top bar. As the load moves 6 inches to either side of bar E, the axial strain in bar E drops off significantly. However, the bending stresses definitely did not reverse, and they remained fairly large, as shown by the distance between the upper and lower curves, indicating the probability of the aforementioned non-uniform support condition. Another interesting point is that bar E went into a slightly tensile condition as the load moved about 3 feet away. Although gage #6 seemed to behave rationally throughout the day of testing, spot tests during the following day yielded vastly different results from gage #6. The repeatability of gage #5 was fair, but that of gage #6 was poor. Based on the overall results of

gages #5 and #6, it is felt that the general magnitude of axial strain is a good "ballpark" figure, but the indication of large bending stresses is probably exaggerated. The axial stresses are of primary concern.

Plot D shows the strains obtained from one side of load-transfer bar D. Notice that the strains follow the same general trend as in Plots C and E. The maximum strain occurred as the concentrated load was 4 inches to the right of bar D, i.e. located centrally between two top bars. As the load moved 2 inches to the left of bar D, i.e. closer to bar D, but above top bar A, the strain dropped off a small amount, indicating the role that the top bars assume in taking some load directly. Without having the average strain in bar D (i.e. results from gage #3) little more can be said except that as the load moved to distances greater than 1 foot from bar D, the strains in bar D were minimal. Moving to plot 5F, a similar situation is presented.

Plot F shows the strain data from gage #8 which was mounted on bar F (see Figure 3). Although the data follow the same general trend as obtained on the other transfer bars, some question remains concerning the accuracy of the data. As was previously stated, gage #8 exhibited a constantly drifting "zero" point. The effect of this was minimized by taking "load" and "no-load" readings with as little elapsed time as possible between readings. This was an effective solution as verified by excellent repeatability checks (taken during the following day). However, the cause of this drift is not known, and neither are the effects of this disorder upon the data. In general then, it is seen that, 1. as the load moved away from bar F, the strains in bar F dropped off rapidly, and 2. the magnitude of

load taken by a bottom anchorage bar that is close to a top anchorage bar is substantially less than in those bottom bars that are mid-way between two top bars. This concludes the individual analyses of the bottom bars under the "concentrated" loading condition. Before proceeding to the 12-inch load distribution, the two instrumented top bars shall be discussed.

Figure 5A shows the axial loads incurred by top bar A. The data was plotted in this manner because the relatively large bending strains in these members would have obscured the important aspect of the data; namely, the amount and direction of force that these bars undergo. The original design loadings indicated that these bars would act in tension, and therefore would contribute to the vertical load transmitted into the bottom bars. Plot A clearly indicates that under the static loading conditions, the opposite is true, i.e. the top bar A actually is in compression and assists the bottom bars in carrying vertical load. The reason for this apparent contradiction is not due to unexpected behavior of the joint. The actual load conditions simply are nothing like the design loads. Specifically, the horizontal force that was used in the design is virtually nonexistent with the static loads, which essentially consisted of vertical load only. This aspect (loading) will be discussed in more detail later in this report.

Referring to plot A, it is seen that the axial load in bar A is largest when the load is directly above the bar. Also, the load taken by bar A drops off by 80% to 100% as the test load moves only 1 foot away, above adjacent top anchorage bars. Notice too, that when the test load was centered between bars A and B, the load in bar

A dropped by one-half. In an ideal structure, when the test load is centered symmetrically between supporting systems, i.e. the supporting system on one side of the load is a mirror image (in a structural sense) of the system on the other side of the load, then each side will respond to the load in precisely the same manner. Hence, in plot A, when it is seen that the strain in a top bar drops by 80% to 100% as the load moves atop an adjacent top bar, it is expected that the strain will drop by 40% to 50% when the load is centered between top bars. Such action is shown in Plot A. Notice the excellent repeatability that was obtained for this pair of gages. It is also very interesting to evaluate the performance of the two top bars simultaneously.

Plot B shows Bar B to be in a slight tensile state (close to zero load) when the test load is above Bar A. When the test load moved above Bar B, this bar incurred its largest axial strains, while Bar A axial strains went into a slightly tensile or zero state. When the test load was centered between the two top bars, it is seen that they "shared" the load. Logically, Bar B shared a larger portion, since Bar B incurred a substantially larger strain by comparison to Bar A when the test load was directly above each of those bars, respectively.

Bar B seems to bring out a very interesting point concerning all of the data in general. Notice how the repeatability checks for Bar B vary. One of them was very close, whereas the other wasn't close at all. Notice also how the axial load in Bar B seems to be so "touchy." It was very large under direct load (large by comparison to bar A); then it dropped to a small tensile load. And as the test load moved progressively farther away, the axial load in Bar B didn't

just ride at zero; it incurred tiny fluctuations in load. It is strongly felt that this sensitivity has nothing to do with the strain gages. This feeling is based on substantial experience with the use of such gages. They are very accurate indicators of strain. In this experiment, some gages were found to be faulty and they are so denoted. The others are providing true and accurate strains, and together, they point out the uncontrollability of the other aspects of field tests, i.e. load variation or non-uniform support from point to point and other things which will be discussed later. Before proceeding to the plots in Figure 6, a brief check on the strains shown in Figure 5 may shed more light on the joint behavior during tests.

It was previously stated that there are indications that the modified bottom anchorage bars take less load than the regular bottom bars, although the differences may be small indeed. An attempt was made to compare the total of the loads measured in the various anchorage bars with the value of the test load. The various plots of Figure 5 indicate that strain levels in all bars become negligible beyond a distance of 2 feet to 3 feet from the load point. This formed the basis for the following analysis.

It was assumed that if all bottom bars were modified, and if the strains in all anchor bars within 3 feet of the test load were measured simultaneously, the results measured at a distance from the load would be the same as the results that were actually obtained from the 1 foot instrumented joint section as the test load was applied at the same respective distance. By totaling all of the loads obtained in this manner, about 21,000 pounds were accounted for (75% of the test load). The question, therefore, is where the other 7,000 pounds were absorbed.

Certainly only a very small amount of weight went undetected due to inaccuracies of the strain gages. The load-transfer bars provided an accurate accounting for vertical loads transmitted into two of the bottom bars. The other two instrumented bottom bars leave considerable doubts of accuracy, but the average figures that were used should be close to correct. Although care was exercised during construction to assure the "floating" condition of the armor, there was a small point of contact between concrete and the armor, although it was about 4 feet from the loaded areas. Having been directly involved through every step of construction and special instrumentation that related to this joint, it is the opinion of the author that the unmodified bottom anchorage bars carried this extra load. As the test load was in the immediate vicinity of the modified section, slightly more load was distributed to the unmodified bars. And as the test load moved above the regions that were not modified, these regions may have been slightly more rigid and therefore carried slightly more load proportionately. This would effectively decrease those stresses that were simultaneously measured in the modified section. In summary, it may be estimated that if the load could be measured for the anchorage bars where no modified bars existed, those loads may exceed the loads shown in Figures 3 and 4 by a few hundred pounds, at most. This concludes the separate analysis of Figure 5. Figure 6 possesses several of the same trends and effects as Figure 5, but it is also interesting to compare the results obtained by use of the 12 inch distribution plate to those of the concentrated load.

3. Distributed Loads

As one compares plots A through F in Figure 6 to the respective plots in Figure 5, it is seen that strains obtained with the 12 inch distribution plate are generally smaller than those from the concentrated load, although a few questionable circumstances exist.

Beginning with plot 6C, gages #1 and #2 on load-transfer bar C demonstrate remarkable similarity to Figure 5C. The sharp stress reversal, as well as the asymmetrical nature of the curve about bar C, are clearly shown. Repeatability checks were all very good. The magnitudes of the strains were less in plot 6C than in plot 5C, which would be consistent with the idea that the load is now distributed more uniformly to other load-carrying bars. Notice that whereas the maximum load in plot 6C dropped (from 5C) by about 33%, it is indicated that as the test load was placed aside of bar C, the strains in bar C were about the same for both the 12 inch and the 4 inch distributions. In essence, this is indicating the disappearance of the "peak" strains as the load is more widely distributed. It is mentioned that strains and loads obtained from the 24 inch distribution plate are shown in Figure 6 and denoted as "*". Although discussion of these data will be elsewhere presented, suffice it to say that the "leveling off" of strains is further supported.

Figure 6E exhibits the same characteristics as 6C in the sense that the behavior of gages #5 and #6 repeats as the loading changes from the 4-inch plate to the 12-inch plate. Comparing plot 6E to plot 5E, a similar asymmetry is exhibited. And, as in the comparison of plots C, the peak strain magnitude in plot 6E is lower than in

plot 5E, while the other strains, measured as the test load moved aside, were very comparable between the two plots. Again, the dissipation of the peak in favor of larger strains in other anchorage members is demonstrated. Comparison of the strains in plot 6D with those in 5D reveals the same trend.

Looking at all of the plots in Figure 6 it may be stated that the width of effective distribution of load is about 3 feet to each side of the load. Beyond that distance from the test load no significant strains were measured.

Finally, in discussion of the 12 inch load distribution plots, refer to plots 6A and 6B which show the axial loads in the top anchorage bars A and B respectively. The results of plot 6A are somewhat confusing. But in general, when the two plots are considered, along with their repeatability checks, they too exhibit the same characteristics as their counterparts in Figure 5. Axial strain in the bars clearly peaks when the test load is directly centered above them. Then it drops by roughly 50% as the load is centered between the two top bars. Then it drops to nothing as the load is centered on the adjacent top bar.

So in general, it has been shown that the 4-inch load plate gives about the same result as the same load distributed over 12 inches. The armored joint senses the 4-inch load condition as a concentrated loading. Figure 6 indicates that when the 12-inch load plate is used, the joint still senses it as a fairly concentrated load. This is particularly true of the top anchorage bars as demonstrated in the preceding paragraph. For bottom bars, the peak strains begin to disappear and more load is picked up by immediately adjacent areas of

the joint. This points out the effect of anchorage bar spacing. The bottom bars are so close that they share the load in a fairly uniform manner.

Top bars do not effectively share load to other top bars that are not in the immediate loading area. This would seem to present a contradiction because the only way that adjacent bars can share the load is through the deflection of the joint armament. One may ask how the armor could deflect on the bottom without deflecting at its top. But actually, a look at Figures 5 and 6 shows that although strains are detected up to 3 feet from the test load, the only sizeable strains are within a foot of the loading. This matter of "sizeable" strains leads into the discussion of the tests conducted with the 24-inch distribution plate.

The strains obtained with the 24-inch plate are shown denoted as "*" in Figure 6 and were of a very low level -- often 30 micro-inches or less. In spite of the overall accuracy of the strain measuring equipment, the percentage of error in such small strains may be large because of other conditions, mainly attributed to imperfect loading and non-uniform load distribution. Hence, it is difficult to detect specific patterns. But one point stands out quite clearly; namely, that the strains incurred due to the 24-inch distribution are very low and indicate that under such loading, which happens to be the same width as a typical dual tire loading, no anchorage bars receive more than 1,000 pounds of load.

All of the preceding analysis of Figures 5 and 6 is worth very little unless it relates to the design of the armored joint. And when this experiment was designed, it was with a few basic points in mind. The ensuing discussion covers these points.

4. Discussion of Loadings

The design of an armored joint is a wide open field of endeavor. This fact is immediately obvious to anyone who tries to design one. Even having some firm conviction of the reasons that an armored joint may be necessary, the designer is hard-put to find any specifications that will provide loadings that will truly be applicable to the situation. Hence, one point of interest is the comparison of the test load with the design loads. The approach is not simply to evaluate the armored joint on the basis of its behavior under the test load and then to project its behavior on the basis of comparison of the test load and the design load. In this case, the design loads themselves form the basis for argument.

In the design of the anchorage for the subject armored joint, AASHTO specifications were consulted. Subsequently, the loads chosen for the design were loads for highway bridges. To simplify this discussion, the resultant design loading was comprised of vertical and horizontal line loads, which were distributed over a 3-foot length of joint. In the design of the joint anchorage, assumptions were made which accounted for the "worst load" condition that could eventually occur. And other assumptions were made for simplification of the joint design, i.e. to render it statically determinate. The results of this design indicated that the top anchorage bars would act in tension, and the bottom bars would support the resultant of this tensile load in addition to the full brunt of the vertical load. The data of this experiment indicate that the converse is true, i.e., the top bars act in compression (and bending), thereby assisting the bottom bars in carrying

vertical load. This fact would seem to indicate a fault in the design approach. But it is noted that the design loads are far different from the test load, which was almost entirely vertical. Hence, the problem is not simply to revise the design. In this case, the validity of using the AASHTO loadings must be questioned.

Although these loads are taken as a concentrated line load, in reality the load would be somewhat distributed due to the size of the tires in use. The assumption is valid for bridge design because the designer is dealing with a gross structure that is so large in terms of mass and size that the structure responds in about the same manner regardless of the assumption. The structure incurs all of the loading within a proportionately small area of itself. In the case of joint armament, the armor is long and very slender. Hence, it is seen that it would be practically impossible to incur the full extent of the loads that are commonly used (and correctly so) in the bridge design. In reality the edge of the design load could be an inch away from the joint armament, and the armor would be under practically no stress (unlike adjacent portions of the bridge). On the other hand, the load could be centered atop the armor, and the armor would directly receive only about 25% of the load because the remainder would be distributed by the tires to the deck slab or the other side of the joint. Indeed, the portion of load that would be applied to the deck would cause its subsequent deflection and could actually serve to reduce the stresses in the joint anchors. In light of these considerations, the degree of severity of the test loading used in these experiments should be examined.

Before any actual load tests began, it was desired to check out the sensitivity of the armament to a truck tire loading, without the benefit of any load concentration apparatus. The loading truck was parked with its rear dual tires centered upon the armored joint. Together, these tires were supporting about 40,000 pounds. All strain gages were balanced. Most of them indicated no measurable strain whatsoever. One or two gages indicated strains that were only barely detectable. In other words, the armored joint scarcely felt the effect of the truck tires. This fits nicely with the results that were subsequently obtained via the hydraulic jack and loading plates. Recalling the analysis of Figures 5 and 6, as the load concentration went from 4 inches to 12 inches and then to 24 inches, the strains dropped off rapidly to the extent that they became so small (with the 24 inch plate) that they were difficult to ascertain with accuracy, and hence, difficult to analyze. All of this demonstrates the non-applicability of the concentrated loading to an armored joint. The armor simply cannot pick up the full extent of the load because in reality the load is distributed to other supporting areas. (Note that if the surface area of the armor increases, so does the proportion of load that it must support. This is a key point in selection of the dimensions of the joint armor). In the case of our tests, the 24-inch plate was supplying at least 6 times the amount of load that a set of dual tires would provide. Hence, the experiment appears to have shed some light upon loadings to be used for design. Since the joint was designed for certain loading, its behavior due to that loading should be examined.

First, the design load called for 10.0 kips/foot over about 3 feet. The test load consisted of 28 kips distributed over 1/3 foot, 1 foot and 2 feet. It is seen that 28 kips/2 feet yields 14 kips/foot over 2 feet, which is roughly equivalent to the design load. Strains obtained from this loading never exceeded one-fourth of the theoretical design strain for the load transfer bars. In view of the rigidity of the armament demonstrated by the results of the more concentrated loading, it is felt that the low strains are due to the fact that when the load application area exceeded the 1 foot spacing of the top bars, the load concentration was significantly reduced to the point that it was distributed by the armor over perhaps as much as a 6 foot length of joint. Based on the fact that the load approximated the vertical design load and the fact that the highest strains were about 1/4 of the theoretical strains, it appears that the approach utilized in the anchorage design is good. But based on the results of the experiment, it appears that for vertical load, it is reasonable to utilize a loading that considers maximum tire pressure and the maximum area of tire to be supported. It also appears that for the spacing of top anchorage used in the experimental joint, and for an armament with the same rigidity, the load distribution used in the design should be increased to perhaps 4 feet, i.e., one foot to each side beyond the actual application area of the load. This concludes discussion of vertical static loads, leaving open the matter of horizontal loads and the effective impact factor due to a dynamic load condition.

With the available loading apparatus, it was not possible to attain a horizontal load. The design approach was to assume that the

horizontal force resulted from tire friction. It is felt that the approach is correct, but again, the vertical load magnitude, on which the friction force is based, should be reduced as stated above.

In regard to dynamic loads, tests were conducted at speeds of about 15 to 20 mph. The same loading vehicle was used as for the static tests. The dynamic strain recording equipment was connected to those gages which were known to be the most accurate and the most responsive to load. The equipment was first tested by inducing a strain on a gage that was mounted on a steel specimen, and it was found that the equipment could clearly detect strains of as little as 10 or 15 micro-inches. The response time of the equipment was well within that required by the dynamic effect of the tire even at 50 mph. The strain levels from the dynamic tests were not readable. The reason, of course, is that the load was distributed by the tires, rather than concentrated as with the jack and loading plates. Therefore, no impact factors were obtained and no changes are recommended. This essentially concludes discussion of the Klockner Road armored joint data. It is realized that readers may be left with some degree of skepticism regarding the experiment's results. Therefore, a few factors that relate to strain gage performance, and the affect of these factors upon the data is worthy of discussion.

5. Discussion of the Data

There are 8 factors that play a direct role either in causing data scatter, or in causing data errors. Three of these factors were definitely not influencing the data in any way. Load magnitude was very accurately controlled by use of an hydraulic jack with a pressure gage. This apparatus was carefully calibrated in a compression testing machine. In the field tests the load was kept within 100

pounds of the 28,000 pound test load. The second factor is the effect of temperature on the delicate strain gage filament. This effect was totally negated by the manner in which the tests were conducted. "Zero" readings were always taken within 1 or 2 minutes of the "full-load" readings, thereby assuring that no significant temperature changes occurred. The third factor was an excessive "zero-point" drift. This was found to be caused by a faulty strain indicator and the equipment was replaced. The replacement equipment was very stable. The other five factors are as follow:

1. Low strain levels;
2. Misalignment of load;
3. Non-uniform load distribution;
4. Instability or total breakdown of a particular gage;
5. Insufficient number of gages.

The low strain levels were unfortunate in that they made it difficult to ascertain trends. Small errors became relatively large when the sizes of the strains were small. It was not possible to increase the sizes of the strains and maintain the structural capacity of the anchorage and joint. If the joint incurred strains at levels that the theory predicted, then this problem would not have occurred. In fact, when the test load was applied as a point load, the strains did become significant, and the problem of interpretation was minimal. It was at the lower level loadings (those that the author suggests as being more realistic for design purposes) that interpretation of the strains became difficult.

There are two load-related conditions that also contribute to

data scatter. Under laboratory control, these conditions may be eliminated. Under field conditions, efforts are made to minimize their extent. The first condition is load misalignment which accounts for off-center and non-vertical loading. The tests indicated that with the concentrated load, a movement of the load center of as little as one or two inches could produce quite a difference in strains. With the conditions under which these tests were conducted, the author feels that the actual center of load could have been anywhere within 2 inches of the intended load point. The effects of this are probably undetectable when the load is distributed over 2 feet of joint length. As the 12-inch and 4-inch distributions are used, the effects would become larger, but did not obscure the general behavior of the joint. The second condition is non-uniform load distribution, which is partly caused by imprecise location of the load center, but which is also caused by the use of an elastic distribution method such as steel plates. Ideally, a pressure system should be utilized. The extent of non-uniform load distribution of these tests is not known, but as with loads misalignment, the general trends in strains were not obscured. The following two factors of discussion are the most important in regard to the scatter and accuracy of the data.

The first factor is instability or total breakdown of a particular strain gage. Gage instability can be caused by several things, many of which can be accounted for, and controlled. But occasionally, a gage behaves in an erratic manner and nothing can be done about it. Some of the gages did this during the Klockner Road

tests and their results either were not presented, or were presented in that light (for example, gage #8). The problem is that one is not sure how unstable a gage is at a particular moment, and hence how reliable the data are. One is therefore forced to expell the data, or to use it very carefully. The way to get around this problem is to install as many extra gages as is feasible and rely only on those that work well. This leads to the final factor of discussion: insufficient number of strain gages. The author was forced to "get by" with an absolutely minimal amount of instrumented joint. Actually, in view of the anticipated load distribution, no less than 6 continuous feet of length of the joint should have been instrumented, and there probably should have been a heavier concentration of gages per foot of joint. Data with doubtful validity would then be rejected and the results would be infinitely more reliable. Concrete conclusions would be drawn instead of general indications.

In summary, the intent of the foregoing discussion was not to discredit the experiment. Indeed, the entire data analysis was presented in light of, not in ignorance of, the quality of the data. The author feels that the conclusions presented hereinafter are sound because they are qualified to that extent.

III. Cypress Lane Armored Joint

A. Instrumentation

Instrumentation was essentially the same for the Cypress Lane tests as for the Klockner Road tests. Since the loads for which this expansion joint may have been designed are not known, the loading that was used on Klockner Road was also used on Cypress Lane. The only differences, therefore, were the placement of strain gages.

The Cypress Lane joint possesses two types of anchorage. The haunch supports shown in Figure 7 serve as extremely rigid anchorage at each girder. In addition to these, 5/8-inch diameter bars on 1 foot centers were also used throughout the length of the joint. Figure 7 also shows the location of gages No. 1, 2 and 3. These gages were placed to detect the moment induced in the haunch under load. Although shear and bearing are probably the critical considerations for the 5/8 ϕ rods, there was no way of measuring these stresses. Instead, at a distance of 4 inches back from the armament, a gage each was placed on the top and bottom of two of these rods, as shown in Figure 8. These gages detect axial tension and compression and bending in the vertical plane. One of the instrumented rods was 14 inches from the haunch. The other was 50 inches from the haunch, or midway between girders and haunches. The rods shall hereinafter be referred to as Rod A and Rod B, respectively.

B. Analysis of Data

Table 1 summarizes the strains measured in the Cypress Lane tests. These results should not be misinterpreted. For example in Case 1 and Case 2 it is seen that no strain was measured in gages #6 and #7 when the load was centered above the haunch. Yet it cannot

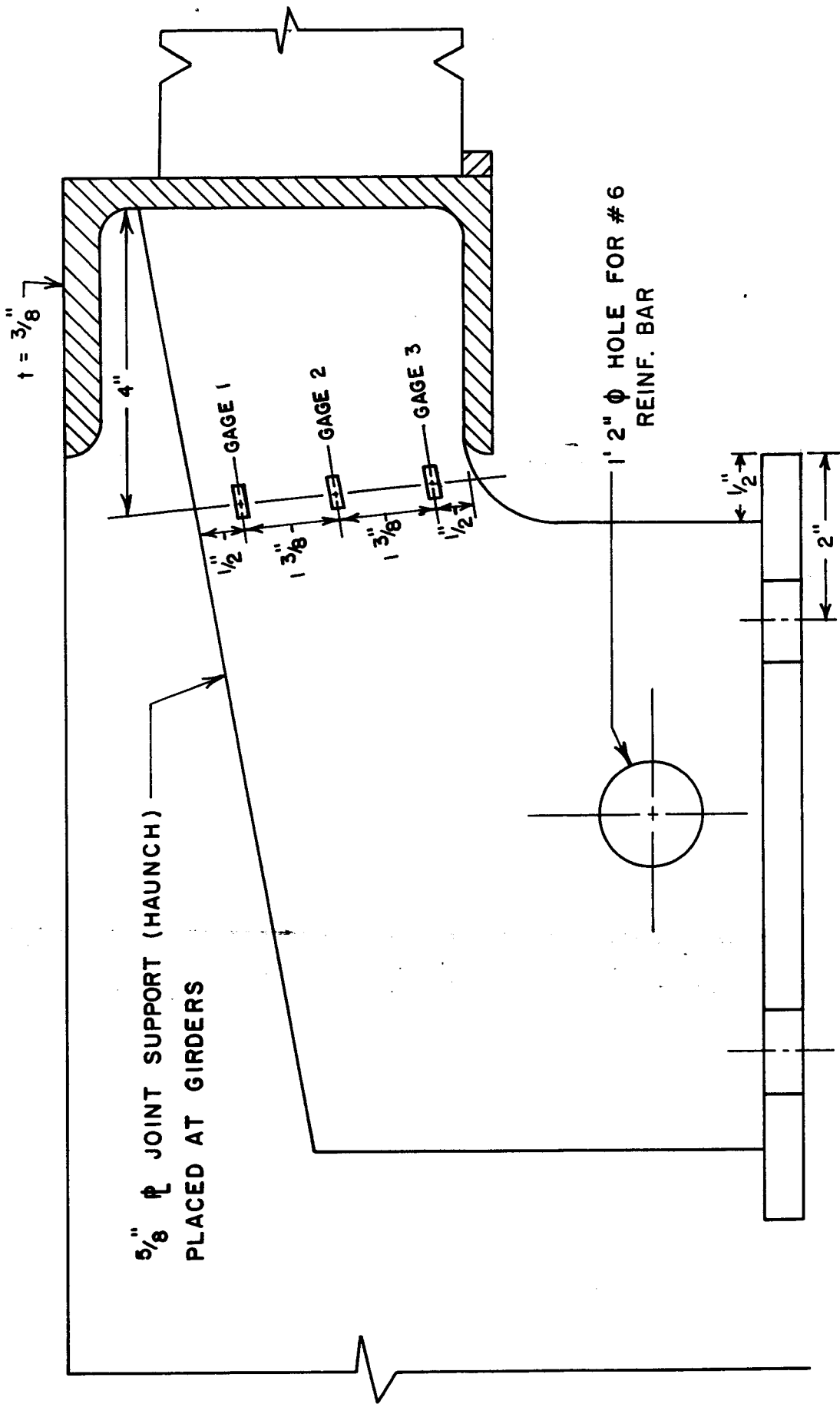

FIGURE 7

TYPICAL SUPPORT HAUNCH FOR CYPRESS LANE ARMORED JOINT

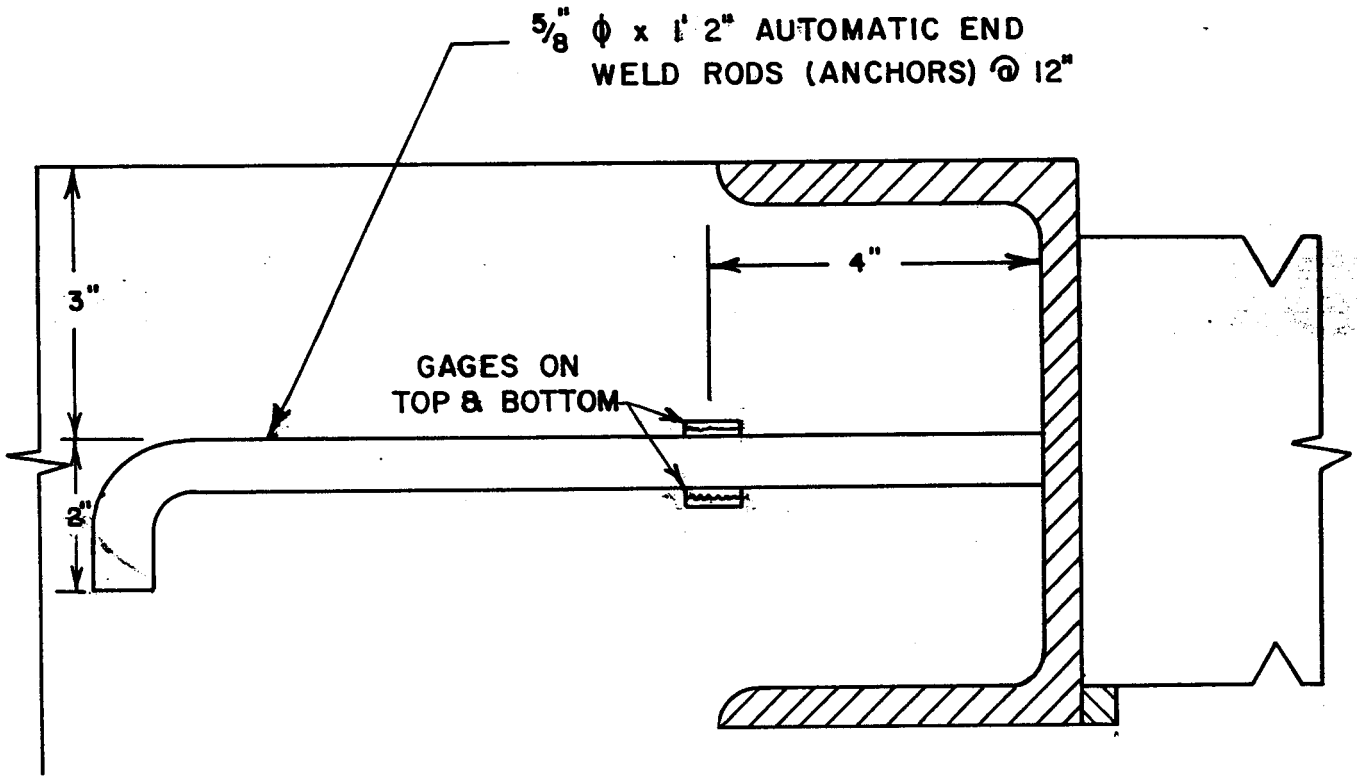

FIGURE 8

ANCHORAGE FOR CYPRESS LANE ARMORED JOINT

TABLE 1 - STRAINS* FROM 28,000 lb. ON VARIOUS LOAD PLATES

Load Distribution Plate Size	Load Position	Haunch Support			Rod "A"		Rod "B"	
		Gage 1	Gage 2	Gage 3	Gage 4	Gage 5	Gage 6	Gage 7
Case 1 4-inch Load Plate	Haunch	+30	Broken	+10	Broken	+10	0	0
	Rod "B"	0	--	0	--	0	+740	+330
Case 2 12-inch Load Plate	Haunch	+25	--	-15	--	+5	+5	-5
	Rod "B"	-5	--	+20	--	+5	+700	+300
Case 3 24-inch Load Plate	Haunch	--	--	--	--	--	--	--
	Rod "B"	0	--	0	--	0	+325	+130

*All strains are in micro-inches per inch;

Negative sign indicates compression;

Positive sign indicates tension.

be said that Rod B carried no load. There may have been some small load in the rods which was not detected because of the fact that the entire rod is encased in concrete and it did not flex at a distance of 4 inches into the concrete.

There are essentially three things that are shown by this data. The first point is that the haunch device was expected to carry a substantial amount of load when the test load was directly above the haunch location. The data do not indicate this to be the case. For instance, Case 2 shows bending strains of about 20 μ -inches. This yields about 27 μ -inches/inch at the extreme fibers, which can be translated into a moment of about 4800#-in. Considering that the approximate center of load application is about 2 inches from the strain gages, this moment would be caused by a vertical load of only 2,400 pounds, or less than 10% of the applied test load of 28,000 pounds. No reasons for this behavior are offered. The instrumentation is simply too scanty to provide more light on this behavior.

The second point of discussion is the large strains that were measured in Rod B when the load was applied directly above Rod B. The 700 and 740 μ -inch strains give combined bending and axial stresses of over 20 ksi. And note that these are not maximum stresses, and there is no consideration of the horrendous bearing stress that probably exist in the concrete beneath Rod B, nor of the shear stresses that exist at the weldment of Rod B to the armament. Even this flexural stress is at the working limit allowed in normal flexural situations. In design of anchor bolts, such high stresses may not normally be permitted because of several other factors, depending upon

the chances that the designer wishes to take. And again, it is repeated that the detected stresses are not the maximum stresses that Rod B may have incurred.

The third point that is brought out by the data relates to distribution of the load. Cases 1 and 2 show that for load position No. 2 (above Rod B) there is little difference in strains between the concentrated load condition and the same load applied over a 1-foot distribution. Case 3 shows that the strains in Rod B drop by roughly 50% when the 2-foot distribution plate was used. As was the case with the Klockner Road armament, the Cypress Lane expansion joint responds to load according to the relationship between the size of the load distribution, and the spacing of the anchorage. In other words, until the load is applied over some length which is greater than the anchor spacing, the joint responds to the load as if that load was truly concentrated. (i.e., a point loading) This suggests that anchor spacing should be kept small to assure that several anchors take the brunt of the load. In the Klockner Road joint, this phenomenon was only noticed in the top anchorage bars because the bottom bars were so closely spaced (4 inches.)

For the Cypress Lane joint there is only one row of anchors and therefore the spacing becomes extremely critical. Little more, if anything, can be drawn from the available strain data. However, there is one more point of interest which resulted from visual observation of load tests.

No attempts were made to measure deflections on either armored joint. And no deflections were visually observed while loading the Klockner Road armored joint. However, when loading the Cypress Lane

armored joint, the top flange of the armor deflected downward by a considerable amount, so much in fact, that the author feared permanent deformation of the flange. The load was immediately removed and recentered closer to the web of the channel section. Testing resumed and deflection of the flange was still quite evident, although not as severe. This deflection brings out two points. First, the top flange should not be too large. Second, the thickness of the armament should be substantial. On the Klockner Road armament, the combination of a shorter flange element (2"), a thicker section (1/2"), and anchor bars welded to the top flange, provided an armament that was not subject to such excessive deflections. Similar overall rigidity should be attained in any armored joint to assure tightness between the armor and the concrete deck. A lack of such rigidity would result in significantly raised stresses and increased infiltration of foreign material beneath the armament to the point of premature deterioration of the entire joint system.

IV. Conclusions From Armored Joint Load Tests

1. Loads for design:

The loads used in the design of the armored joint should be taken as a tire pressure distribution applied over a certain area unless it can be shown that a rigid loading device would be incurred which would provide a more severe case of loading. This area would more realistically be a reduced portion of tire(s) and the pavement. AASHTO loads for bridge decks do not appear to be appropriate when taken as a concentrated load on the armament.

2. Rigidity in the vertical plane:

Rigidity in all planes is important for an armored joint because it is usually an integral part of a somewhat less durable concrete deck. The overall system rigidity is of primary consideration since it affords the most economical balance between anchorage and the armor itself. Heavy armament and scanty anchorage provides the simplest fabrication and construction along with undesirably high anchorage stresses and stress concentrations. Light armament and excessive anchorage increases fabrication and construction costs and may result in premature joint failure.

The Klockner Road armored joint appeared to exhibit a well-balanced system. No noticeable deflections occurred under load. However, based on the stress levels obtained from the tests it appears that fewer (than presently used) bottom anchorage bars may be warranted, without deleterious affects on system rigidity.

3. Rigidity in the horizontal plane:

The 12-inch top anchor spacing utilized on the Klockner Road

joint provided excellent horizontal rigidity to an armament which otherwise might have been deficient in this regard. The Cypress Lane armament achieved horizontal rigidity through increased flange width only.

4. Anchorage details:

The method of combined upper and lower anchors was clearly shown to be immensely superior to one row of anchorage as used on the Cypress Lane joint. The upper bars 1. assist in load carrying capacity of the joint, 2. distribute incurred loads more than a single row of anchors, 3. provide horizontal rigidity where it is needed the most without resorting to an increased flange size. The tests showed that the single row of anchors used at Cypress Lane were inept at holding the armament tightly as an integral part of the deck; that they instead act as an elastic hinge about which excessive rotation occurs.

5. Armor selection:

To be sure, extensive testing of various armament and anchorage combinations is needed in order to provide the best armored joint system. However, even these limited tests provide indications that in general the armament should be kept thick, while the top flange should be kept small. A small flange allows for good concrete compaction beneath the armor and presents a minimal area to incur tire loading (reducing overall load magnitude and subsequent stresses), while still protecting the top corner of the joint faces.

6. Critical anchor spacing and Load Distribution:

The tests on Klockner Road indicate that maximum anchor spacing should be closely related to the load application area. An economical

armor section will not be so rigid that it distributes load over several feet of width. Therefore, a sufficient number of anchors should be within or near the load application area such that they share the load and thereby do not allow high stresses in any one anchor. In view of the recommended reduced loading (Conclusion No. 1) and the low stresses that were obtained the author tends to feel that the bottom anchor spacing of 4 inches should be increased. The top spacing of 12 inches should not be increased under any circumstances since these anchors provide horizontal rigidity to the top of the system, and since this spacing already places a minimal number of top anchors within the immediate vicinity of an applied tire load.

The limited scope of the load tests did not yield much information regarding load distribution for armored joints in general. The distribution will vary according to the anchorage and armor utilized. For the Klockner Road joint it is felt that a total of 4 feet of joint length should be assumed to carry all of the design load.

7. General:

The armored joint at Klockner Road appears to be slightly over-designed with respect to lower anchorage bars.

By comparison the armored joint at Cypress Lane appears to have a few major deficiencies, which primarily relate to poorly located and under-designed anchorage. Under maximum loads, these anchors have little if any safety factor. If the true maximum stresses could have been determined, it is felt that a fatigue analysis would indicate early failure in these anchors if used on a primary highway system.

Further tests are necessary in order to determine with accuracy the most economical balance of anchorage and armament, as well as a more detailed picture of stress behavior. Static tests of sections of

armored joints would appear to lend themselves well to laboratory conditions.