

IMPROVED DRAINAGE AND FROST ACTION CRITERIA FOR  
NEW JERSEY PAVEMENT DESIGN, VOLUME III

ROAD SUBSURFACE DRAINAGE DESIGN,  
CONSTRUCTION AND MAINTENANCE GUIDE  
FOR PAVEMENTS

A Final Report

March 1984

BY

GEORGE S. KOZLOV, AUTHOR

Division of Research and Demonstration  
New Jersey Department of Transportation

In cooperation with  
U. S. Department of Transportation  
Federal Highway Administration

"The contents of this report reflect the views of the author who is responsible for the facts and the accuracy of the data presented herein. The contents do not necessarily reflect the official views or policies of the State or the Federal Highway Administration. This report does not constitute a standard, specification, or regulation."

1. Report No. FHWA/NJ-84/015		2. Government Accession No.		3. Recipient's Catalog No.	
4. Title and Subtitle Improved Drainage and Frost Action Criteria for New Jersey Pavement Design, Volume III - Road Subsurface Drainage Design, Construction and Maintenance Guide for Pavements"				5. Report Date March 1984	
				6. Performing Organization Code N.A.	
7. Author's: George S. Kozlov, Project Engineer				8. Performing Organization Report No. 84-015-7740	
9. Performing Organization Name and Address New Jersey Department of Transportation Division of Research and Demonstration 1035 Parkway Avenue Trenton, NJ 08625				10. Work Unit No. N.A.	
				11. Contract or Grant No. NJ HPR Study 7740	
12. Sponsoring Agency Name and Address Federal Highway Administration Washington, D.C. 20590				13. Type of Report and Period Covered Final	
				14. Sponsoring Agency Code	
15. Supplementary Notes Prepared in cooperation with the FHWA. An annotated listing of the other publications prepared as part of this research is presented on pages xi - xiv.					
16. Abstract  This Volume III report of a three-volume series on subsurface road drainage is offered as a guide for solving the problem of road subsurface drainage. The intent is to formulate improved design methods and construction and maintenance procedures for road internal drainage systems as a means for controlling water within pavements. This guide is an effort to provide internal road drainage systems capable to control water internal movements, at least to limit its damaging effect and to extend road life expectancy. The solutions offered are expected to be structurally sound and cause no adverse frost effects.					
17. Key Words Subsurface drainage, infiltration water, ground water, drainage layers, collector systems, interceptor drains, rational analytical methods.				18. Distribution Statement  Copies available on request	
19. Security Classif. (of this report) Unclassified		20. Security Classif. (of this page) Unclassified		21. No. of Pages 166	22. Price

## IMPLEMENTATION STATEMENT

To facilitate the early implementation of the internal road drainage, design concepts developed in this research were outlined in a 1981 Memorandum Report entitled "Design and Application Details for Highway Drainage Layers". This preliminary report provided the Department's pavement designers with sufficient information to begin incorporating the drainage layer concept into new construction projects. As a result, the highway underdrain system proposed by the research was used on the truck weigh station on Route I-78 and will be used on Route 55, Section 13B. Due to the potential for increased life for pavements with subsurface drainage, this system is also being considered for inclusion into the final sections of Route I-287 and the Route I-78 Alpha by-pass.

Another early publication resulting from this research -- the "Road Surface Drainage Design Construction and Maintenance Guide for Pavements" -- recommended improved surface drainage design procedures which, when coupled with the developed internal drainage procedures, can provide the most advantageous solution to the problem of water buildup beneath the roadway. These surface drainage procedures have yet to be implemented.

In general, throughout this study, the researchers worked closely with the personnel from the operative divisions which would be using the findings of this research. To further aid in the implementation of the research findings and to avoid any possible misapplications of the proposed solutions, a mutually beneficial continuation of the cooperation between Research and operating personnel is suggested until at least several large projects have been completed. To facilitate such implementation, the permeameter and the modified compaction equipment have been improved and standardized for easy fabrication and application. These efforts might result in procedural design refinements.

## ACKNOWLEDGMENTS

The intent of this guide is to provide the highway engineer with a systematic means for solving the internal drainage problems of roadways. Since part of it, concerning groundwater problems, deals with the basic engineering of drainage, its solution is based heavily on available drainage engineering literature. The largest portion of the guide, concerning infiltration water drainage, covers solutions developed by this research and therefore are innovative and original, even though some similar approaches had been suggested elsewhere. In this vein, the past and present members of the research team but especially Bruce Cosaboom, Victor Mottola, and Gregory Mehalchick, are very deservingly complimented on a job well done.

In some instances concerning groundwater and design in general, the information in a particular reference is considered directly applicable to the Department's needs and verbatim excerpts are used. However, for practical reasons, quotes are often omitted. Permission for such use of reference documents has been solicited and secured from Professor Moulton, the author of a source mentioned below. In presenting this guide then, an expression of appreciation goes to the following organization and individuals:

1. FHWA, Mr. Harry R. Cedergren, Mr. George A. Avman, and Mr. Ken H. O'Brien, "Development of Guidelines for the Design of Subsurface Drainage Systems for Highway Pavement Structural Sections", February, 1973.
2. FHWA, Dr. Lyle K. Moulton, Ph.D., P.E., "Highway Subdrainage Design", August, 1980.

TABLE OF CONTENTS

	Page
Index of Figures .....	vi
Index of Tables .....	x
A. Introduction and Background .....	1
B. General .....	2
C. Design of Drainage for Subsurface Water Infiltration .....	3
C.1 Highway Geometry .....	4
C.2 Subsurface Geometry.....	5
C.3 Design of the Subsurface Drainage Layer .....	11
C.3.1 Water Infiltration and Principals of Subsurface Drainage .....	14
C.3.2 General Types and Applications of Open Graded Drainage Layer Materials .....	18
C.3.3 Non-Stablilized Open Graded Material Properties and Laboratory Test Procedures .....	20
C.3.4 Bituminous Stabilized Open Graded Material Properties and Laboratory Test Procedures .....	25
C.3.5 Barriers .....	28
C.4 Design of Water Collection Systems .....	37
C.4.1 General .....	37
C.4.2 Longitudinal, Transverse Collectors and Outlets .....	37
C.5 Subsurface Drainage Geometry Design Example .....	50
C.5.1 Internal Drainage Design Example .....	54
D. Design of Groundwater Drainage .....	56
D.1 General .....	56
D.2 Classification of the Highway Groundwater Subdrains .....	58
D.3 The Design Analysis .....	62

TABLE OF CONTENTS (Continued)

	Page
D.4 Basics of the Rational Analytical Methods .....	62
D.4.1 Application of Rational Analytical Methods Examples .....	65
D.5 Interceptor Drains Design Principles .....	68
D.5.1 Analysis of an Interceptor Drain .....	74
D.6 Miscellaneous Groundwater Drainage .....	77
E. Construction and Maintenance .....	77
E.1 General .....	77
E.2 Construction of Collection Systems .....	80
E.3 Construction of NSOG and BSOG Drainage Layers .....	82
E.4 Maintenance of Subsurface Drainage Systems .....	90
F. Subsurface Drainage and Pavement Rehabilitation .....	92
F.1 General .....	92
F.2 Design Guidelines for Rehabilitation of Pavements .....	94
F.3 Methods of Construction .....	95
References .....	100
 <u>APPENDICES</u>	
Appendix A. Drainage Layer Flow Rates, (Q) and Flow Path Lengths (L) ...	102
Appendix B. Construction and Material Specification for BSOG (Bituminous Stabilized Open Graded) and NSOG (Non- Stabilized Open Graded) Drainage Layers and Subsurface Drainage Collectors .....	108
Appendix C. Falling Head Permeability Test for Open Graded Materials .....	132
Appendix D. Laboratory Compaction Tests and Equipment for BSOG and NSOG Materials .....	138

1

INDEX OF FIGURES

	Page
Figure 1. Paths of Flow of Surface Water on Portland Cement Structural Section.....	6
Figure 2. Path of Subsurface Water in Drainage Layer .....	7
Figure 3. Undrained Roadway Section on Vertical Curve (SAG).....	10
Figure 4. Transverse Drains Are Needed on Superelevated Curves.....	10
Figure 5. Internally Drainable Road Cross-Section With Drains At the Edge of Pavement.....	12
Figure 6. Internally Drainable Road Cross-Section With Drains At the Edge of Shoulder.....	12
Figure 7. Road Cross-Section Drainable to the Edge of Pavement Collectors .....	13
Figure 8 . Road Cross-Section Drainable to the Edge of Shoulder Collectors .....	13
Figure 9. Relation Between Slope and Length of OG Base for 50% Degree of Drainage .....	19
Figure 10. NSOG Gradation Range.....	22
Figure 11. BSOG Gradation Range.....	26
Figure 12. NJ NSOG and Base and Subbase Materials.....	34
Figure 13. Barenberg's Test Site.....	36
Figure 14. Typical Detail of the Edge of Pavement Subsurface Drainage Collectors .....	39

INDEX OF FIGURES (Continued)

	Page
Figure 15. Typical Detail of the Edge of Shoulder Subsurface Drainage Collectors.....	40
Figure 16. Typical Transverse Ditch Detail.....	41
Figure 17. Typical Detail of Drainage Outlet Rip-Rap.....	42
Figure 18. Typical Outlet Pipe Entrance Detail.....	43
Figure 19. Nomogram Relating Solution of Manning Pipe Flow Equation to the Product of a Drain's Flow Rate and the Distance Between Outlets.....	48
Figure 20. Route 195 Subsurface Drainage Geometry Design Example.....	51
Figure 21. Route 195 Pavement Cross-Section.....	53
Figure 22. Longitudinal Interceptor Drain Used to Cut Off Seepage and Lower the Groundwater Table.....	60
Figure 23. Artesian Flow of Groundwater Into a Pavement Drainage Layer.....	61
Figure 24. Chart for Determining Flow Rate in Horizontal Drainage Blanket.....	64
Figure 25. Rigid Pavement Section in Cut-Dimensions and Details.....	66
Figure 26. Flow Toward a Single Interceptor Drain.....	69
Figure 27. Flow Toward a Single Interceptor Drain When the Drawdown Can Be Considered to Be Insignificant.....	70
Figure 28. Chart for Determining Flow Rate in Interceptor Drain.....	72
Figure 29. Chart for Determining Drawdown Curve for Interceptor Drains.....	73

INDEX OF FIGURES (Continued)

	Page
Figure 30. Interceptor Drain's Analysis .....	76
Figure 31. Route 46. Placing BSBC Material on Top of NSOG Layer. Normal Truck Rutting Delivering BSBC Mix .....	79
Figure 32. Route 46. Placing BSBC Layer. Truck Rutting Caused By Unnecessary Wheel Spinning .....	79
Figure 33. Route 195. Drainage Ditch with Filter Cloth Lining .....	81
Figure 34. Route 195. Example of a Daylighted Outlet Pipe .....	81
Figure 35. Route 195. Placing of the NSOG Layer by an Asphalt Paver .....	83
Figure 36. Route 195. Placing of the BSOG Layer by an Asphalt Paver .....	83
Figure 37. Route 195. The NSOG Layer is Being Compacted by a Vibratory Roller .....	84
Figure 38. Route 195. The BSOG Layer Compaction by a Three Wheel and Tandem Roller .....	84
Figure 39. Route 195. Monitoring of the Control Strip Compaction By a Nuclear Gauge .....	86
Figure 40. Route 676. Pouring of Portland Cement Concrete on the Top of BSOG Layer .....	88
Figure 41. Route 195. Paving of Bituminous Stabilized Base on the Top of the BSOG Layer .....	88
Figure 42. Route 676. Fine Grading of the NSOG Material .....	89
Figure 43. Route 676. Portland Cement Concrete Paving Operation on the Top of the NSOG Layer .....	89

APPENDICES

	Page
C1. Modified Falling Head Permeameter Assembly .....	136
C2. Modified Permeameter Accessories .....	137
D1. BSOG Compaction Equipment Assembly .....	140
D2. BSOG Compaction Equipment Accessories .....	141
D3. Modified Burmeister Equipment Assembly .....	146
D4. Modified Burmeister Equipment Accessories .....	147

INDEX OF TABLES

	Page
Table 1. NJDOT Standard Sizes of Course Aggregates.....	21
Table 2. Classification of New Jersey Base and Subbase Materials Into the AASHTO and the Unified Systems.....	31
Table 3. Gradation of NSOG and Base and Subbase Materials.....	33
Table 4. NSOG and Base and Subbase Materials Gradation Characteristics.....	35
Table 5. NSOG to Base, Subbase Materials Filtration Characteristics .....	35
Table 6. Examples of Pipe Backfill Filter Criteria.....	45

APPENDICES:

A1 - Drainage Layer Basic Data .....	103
D1 - Compaction and Permeability Data Sheet.....	144

ADDITIONAL REPORTS PREPARED FOR THIS PROJECT

1. Cosaboom, Bruce, "Project 7740 - Frost and Moisture Data Gathering - Technical Note #1," NJDOT, Division of Research and Demonstration, August 1977. (Unpublished.)

This report describes the effort to collect frost and moisture data using nuclear moisture monitoring equipment and frost tubes which were installed in New Jersey highways. A summary of the data is also presented.

2. Berg, Richard L. and Richard W. McGaw, "Improved Drainage and Frost Action Criteria for New Jersey Pavement Design, Phase 2: Frost Action," Special Report 78-9, U. S. Army Corps of Engineers, CRREL, May 1978.

This report documents the research performed by CRREL to determine temperature transfer characteristics and frost susceptibility of New Jersey's highway construction material. Pavement base and subbase materials as well as the newly developed open-graded bases were tested.

3. Kozlov, George S. and Bruce Cosaboom, Commentary on CRREL's Special Report 78-9, "Improved Drainage and Frost Action Criteria for New Jersey Pavement Design, Phase 2: Frost Action," NJDOT, Division of Research and Demonstration, February 1979. (Unpublished.)

This report discusses the results and implications of CRREL's research into roadway construction materials, performed under contract with New Jersey.

4. Berg, Richard L., "Improved Drainage and Frost Action Criteria for New Jersey Pavement Design, Phase 2: Frost action - Data Analysis," Special

Report 79-15, U. S. Army Corps of Engineers, CRREL, May 1979.

This report analyzes temperature, frost and moisture data collected by New Jersey from 1975 through 1977. Frost penetration using actual measured values are compared to calculated values from a modified Berggren equation. The effects of an open-graded layer on frost depth penetration is also discussed.

5. Barker, Walter R. and Robert C. Gunkel, "Improved Drainage and Frost Action Criteria for New Jersey Pavement Design, Phase III Structural Strength of Pavement with Open-Graded Bases," Geotechnical Laboratory, U. S. Army Engineer Waterways Experiment Station, Report No. 79-002-7740 , August 1979.

This report documents the laboratory tests performed by WES under contract with New Jersey on five New Jersey base courses. Three of the materials were conventional bases, the other two open-graded aggregates bases. Gyrotory shear and repeated load triaxial compression tests were conducted to determine the relative performance of each material.

6. Barenberg, Ernest J. and Douglas Brown, "Modeling of Effects of Moisture and Drainage of NJDOT Flexible Pavement Systems," Special Report for FHWA, NJ 7740, April 1981.

This report describes the tests and the results of a model test track experiment which was designed to compare performance of conventional flexible pavement sections to those containing open-graded bases when subjected to various moisture conditions and simulated traffic loading.

7. Kozlov, George S., "Road Surface Drainage Design, Construction and Maintenance Guide for Pavements," Technical Guide-NJDOT, Division of Research and Demonstration, June 1981.

This technical guide presents a summary of the surface drainage knowledge necessary for the design, construction and maintenance of pavements. Procedures with examples are provided.

8. Barenberg, Ernest J., "Effect of Moisture and Drainage on Behavior and Performance of NJDOT Rigid Pavement Systems," Special Report for FHWA, NJ 7740, July 1981.

The tests and results of a model test track experiment, designed to compare the performance of conventional rigid (PCC) pavement sections to those containing open-graded bases when subjected to various moisture conditions and simulated traffic loadings are presented in this report.

9. Kozlov, George S., Victor E. Mottola and Gregory Mehalchick, "Improved Drainage and Frost Action Criteria for New Jersey Pavement Design, Volume I - Investigations for Subsurface Drainage Design," NJDOT, Division of Research and Demonstration, Report FHWA NJ 7740, October 1982.

This report presents an assessment of the state-of-the-art for subsurface road drainage. The laboratory efforts which were undertaken to identify optimum materials for pavement underdrainage is described. Also, included are summaries of laboratory tests performed by CRREL and WES to determine frost effect and structural properties of conventional and open-graded drainage bases.

10. Kozlov, George S., "Improved Drainage and Frost Action Criteria for New Jersey Pavement Design, Volume II - Experimental Subsurface Drainage Applications Pavements," NJDOT, Division of Research and Demonstration, Report FHWA, NJ 7740, April 1983.

This report describes the initial investigation into the need for subsurface drainage in New Jersey, in addition, the construction, instrumentation and initial monitoring of several roadways employing an innovative underdrainage system containing open-graded bases and longitudinal drains is presented. Also, documented are the results of model test track experiments performed at the University of Illinois.

## A. INTRODUCTION AND BACKGROUND

A lot has been said about the need for a solution to the problem of water in pavements. A necessity for a well organized, practical and relatively simple subsurface road drainage manual exists therefore for a long time. For just as long a time, solutions of groundwater problems were too often incorrectly combined with the surface infiltration phenomena, causing at times inefficiency of the first and ineffectiveness of the latter. This guide is an attempt to remedy this situation.

Research by the NJDOT has confirmed that pavement serviceability can be improved if water is not allowed to accumulate within a pavement's structural section. Adequate surface drainage combined with appropriate internal or subsurface drainage offers the only practical way of preventing water buildup beneath a roadway. In this vein, use of a drainage layer immediately below the lower bound layer of a pavement has been found to be the most effective means of achieving the necessary degree of internal drainage. In actual application the drainage layer, intended to drain off only water that normally penetrates the pavement surface, replaces the top four inches of the highest unbound layer in the pavement section and extends the full width of the roadway. Water accumulated in the layer is drained horizontally to a collection system with appropriate outlets. The longitudinal drainage ditches can be located at either the edge of the pavement or the edge of the shoulder. Such a system, designed to handle surface infiltrated water, should be incorporated into all roadway designs.

The groundwater drainage, besides the intercept of the seepage above an impervious boundary by cut off trenches, must also lower the water table. The

latter source of water can also be removed by a drainage blanket or a well system. This blanket in contrast to the drainage layer for roof water (water which infiltrates fromn the surface) removal, must be designed and constructed so as to remove all water as quickly as is reasonably possible. This will require an adequate thickness of highly permeable material, positive outlets and protective filter layers. It should be located beneath a structural layer, such as subbase, on the top of the subgrade.

The introduction of a positive roof water drainage system also might make the use of the pavement joints sealing for the purpose of keeping water from the road's subbase virtually unnecessary. The reason for this is that practically there is no such thing as an effective sealer and the introduction of an efficient drainage makes application of pavement joint sealer useful only for keeping incompressibles out of a joint.

In this way, the two above-mentioned internal water drainage sources call for TWO TOTALLY AND DISTINCTLY DIFFERENT DRAINAGE APPROACHES AND SOLUTIONS. The purpose of this guide is then to provide rational design approaches and practical applications of such drainage systems.

## B. GENERAL

Subsurface water can exist in the forms of water vapor, bound water, capillary moisture and free water. Except for free water, this guide will not consider the other forms of moisture unless due to cooling or some other moisture transformation phenomena, the water can be drained off by gravitational means. Thus, only two major sources of water remain, infiltration of surface or roof water and groundwater.

As stated in the introduction, the basic principles of drainage engineering developed by this research include draining the roof water through the use of a drainage layer with collector trenches and appropriate outlets that should be a standard feature of all new pavements. The groundwater drainage systems will be used only when groundwater is deemed to be a problem. It can be in the form of longitudinal or transverse drains to intercept flow, or drainage blankets or well systems to lower the water table and relieve pore water pressure.

### C. DESIGN OF DRAINAGE FOR SURFACE WATER INFILTRATION

The validity of the design procedures presented in this guide depend in a large degree upon the accuracy and completeness of the design, application and construction requirements. The solutions developed by this research are as realistic as possible, while still retaining engineering integrity.

The requirements for the design and application of the subsurface drainage can be placed in the following categories.

1. The geometry of the flow domain;
2. the properties of the drainage materials;
3. the proper employment of the drainage facilities and the means for that;
4. and climatological data.

The geometry of the flow involves both the geometric design of the highway, related subsurface drainage geometry and the prevailing conditions as described in Section C.1. It also helps to define the various subsurface drainage problems and to provide the boundary conditions that govern their solution as indicated in Section C.2.

The drainage material's fundamental properties such as permeability, density, geological characteristics, particle shape, etc. define the material's performance and are outlined in Section C.3. To perform properly, a drainage material must transmit the flow of water, properly support loads, and most importantly retain these characteristics for a reasonable life span of a road.

Proper employment of such characteristics for the design and the application of the drainage facilities also require suitable life time maintenance of the system.

The climatological data provide an insight into the fundamental source of all subsurface water and the potentially adverse effects of frost action. In this guide there is no need for further consideration of the hydrology or frost action criteria already discussed elsewhere (3,6).

#### C.1 HIGHWAY GEOMETRY

Almost all of the geometric design features of a highway can exert some influence upon the subsurface drainage. Therefore, before beginning the design of the subsurface drainage system the designer should be armed with as much information as possible on proposed geometric features. The data assembled should include: (a) longitudinal grades; (b) transverse grades (including superelevations); (c) widths of pavement, shoulder surface, base and subbase; (d) required thickness of pavement elements based on normal structural design practice for the particular area under consideration; (e) depths of cuts and fills; (f) recommended cut and fill slopes; and (g) details of ditches and other surface drainage facilities. Ideally, when gathering this information the designer will have available a finished detailed set of typical cross-sections

and profiles. At a minimum, a set of roadway cross-sections showing original ground and at least the gross features of the proposed construction (i.e., cut and fill slopes, ditches, etc.) must be available.

The designer should also have available a topographic map of the highway corridor upon which the final highway alignment has been superimposed. This map should be prepared to such a scale (100 or 200 scale) that features pertinent to both surface and subsurface drainage can be clearly identified. For example, streams, lakes, and seasonally wet areas above the highway may constitute known boundaries to the flow domain.

## C.2 SUBSURFACE GEOMETRY

As shown in Figure 1, the flow of water in the pavement's drainage layer is largely controlled by the longitudinal grade of the roadway,  $S_{long}$  and its cross slope,  $S_{cross}$ . The actual flow paths will be as depicted in Figure 2.

As outlined in the subject figures, when a road's profile is relatively flat, water entering the drainage layer will flow laterally by virtue of the layer's cross slope and empty into the longitudinal collector drains. However, when there is a profile grade, the water will also flow in the direction of the grade. In certain situations, the combination of profile grade and cross slope will be such as to cause exceedingly long drainage flow paths. In these instances, sufficient elevation head can be created to cause water in the drainage layer to actually bleed out of the pavement prior to reaching the collector drains. Also, the time needed for the water to reach the collector can be exceedingly long, creating an extended period of subbase soaking and softening. To prevent these potential problems, transverse interceptor trenches with drainage pipes must be constructed at appropriate locations along the roadway.

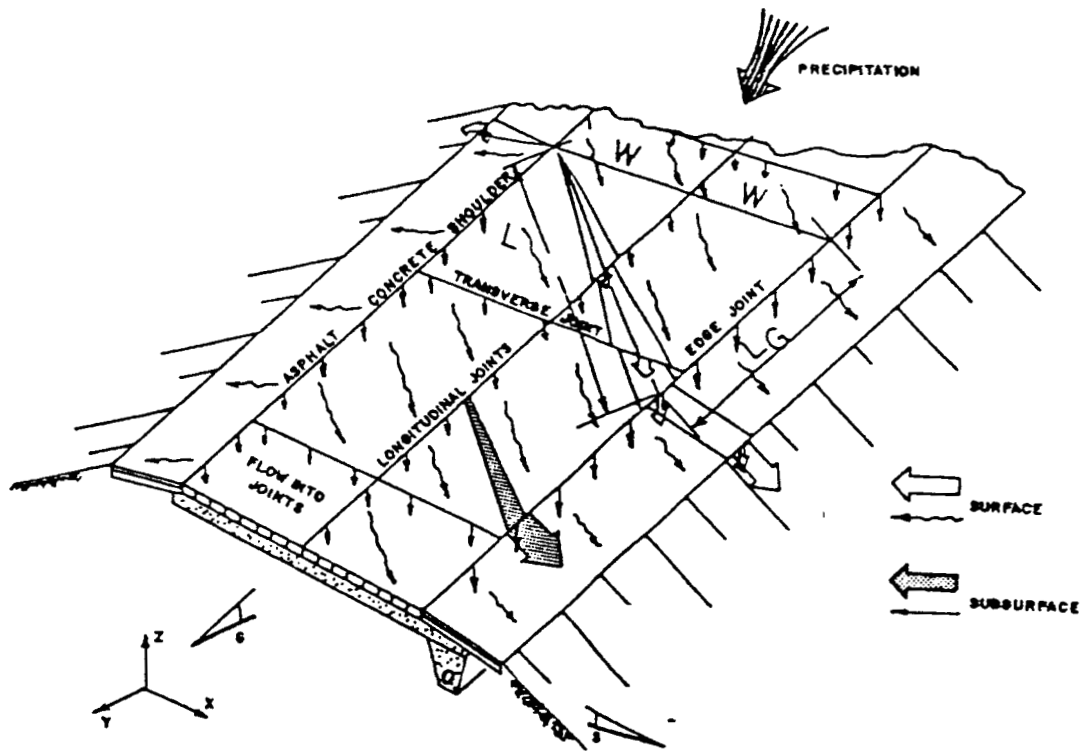

FIGURE NO.1 PATHS OF FLOW OF SURFACE WATER IN PORTLAND CEMENT CONCRETE PAVEMENT STRUCTURAL SECTION

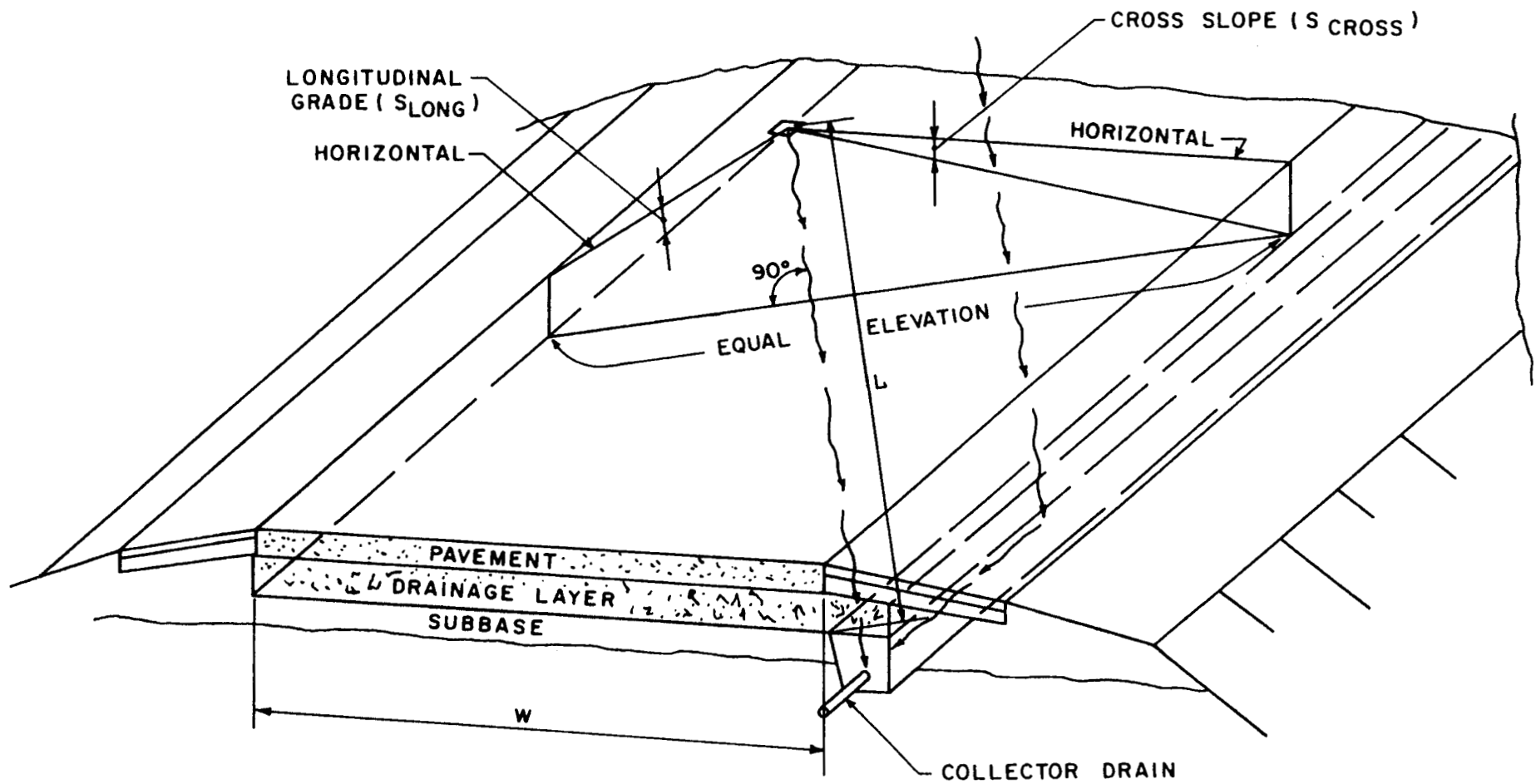

FIGURE #2. PATH OF SUBSURFACE WATER IN DRAINAGE LAYER.

The location of the interceptor cross drain depends on the particular roadway geometry. According to Cedergren, et al<sup>(1)</sup>, "In hilly terrain, the flow paths in subsurface drainage layers should never be allowed to reach excessive lengths. To prevent this, it is recommended that cross drains be required wherever needed to prevent the flow paths from exceeding approximately 150 feet."

For a particular roadway site, a good estimate of the maximum flow path length for a single lane of pavement can be obtained thru use of equations C1 and C2. Equation C3 computes the distance of flow parallel to the grade which is helpful in establishing the actual station locations of any needed cross drains.

$$S_1 = \sqrt{S_{\text{cross}}^2 + S_{\text{long}}^2} \quad (C1)$$

$$L = W \sqrt{1 + \left( \frac{S_{\text{long}}}{S_{\text{cross}}} \right)^2} \quad (C2)$$

$$L_G = W \frac{S_{\text{long}}}{S_{\text{cross}}} \quad (C3)$$

Where

- $S_{\text{cross}}$  = highway lane cross slope (ft/ft)
- $S_{\text{Long}}$  = highway lane longitudinal slope (ft/ft)
- $S_1$  = slope of the flow path (ft/ft)
- $W$  = width of drainage layer (lane width) (ft)
- $L$  = length of drainage path (ft)
- $L_G$  = distance water has travelled in the direction parallel to the grade

Where multi-lane facilities are involved, the total length of flow path is

calculated by adding together the individual determinations for each lane. However, as a quick means of checking if the 150 foot upperbound of the flow length will be exceeded, it is suggested that use be made of the tabulations given in Appendix A. Flow path lengths for a wide spectrum of typical cross slopes, lane widths and numbers, and profile grades are also provided. These tabulations indicate that in most of the situations encountered in "highway" construction in New Jersey, there will be no need for transverse intercept drains. The roads where such drains would be necessary typically involve construction on the county and municipal route systems where steeper longitudinal slopes are encountered.

Exceptions to the preceding guidelines occur when there is a vertical curve or a superelevated horizontal curve. The low point in a vertical curve should have an transverse interceptor drain to facilitate the rapid removal of water from the drainage layer and prevent the buildup of pore pressures (see Figure 3). When there is a superelevated curve on a roadway with longitudinal edge drains, it might be necessary at the transition point of the superelevation to use a transverse drain to prevent the change in flow directions from causing excessively long flow paths. This is illustrated in Figure 4.

Transverse drains must also be used at each underdrain outlet to convey water from the longitudinal drains to the outlet facility. Except for vertical sag and superelevated curve conditions, transverse drains should be placed at about a 45 degree angle to the longitudinal pipe line.

Normally, the outlet pipes should be "daylighted". If this is not possible, then they should be drained into the nearest inlet structure. When the latter is the case, it is imperative that the flow line of the subsurface drainage

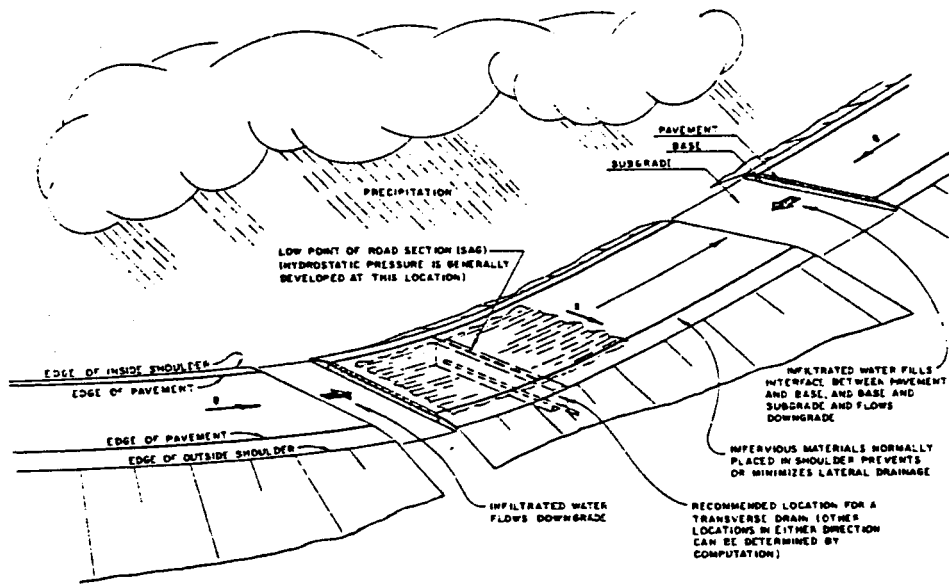

FIGURE NO. 3 ROADWAY SECTION ON VERTICAL CURVE (SAG)

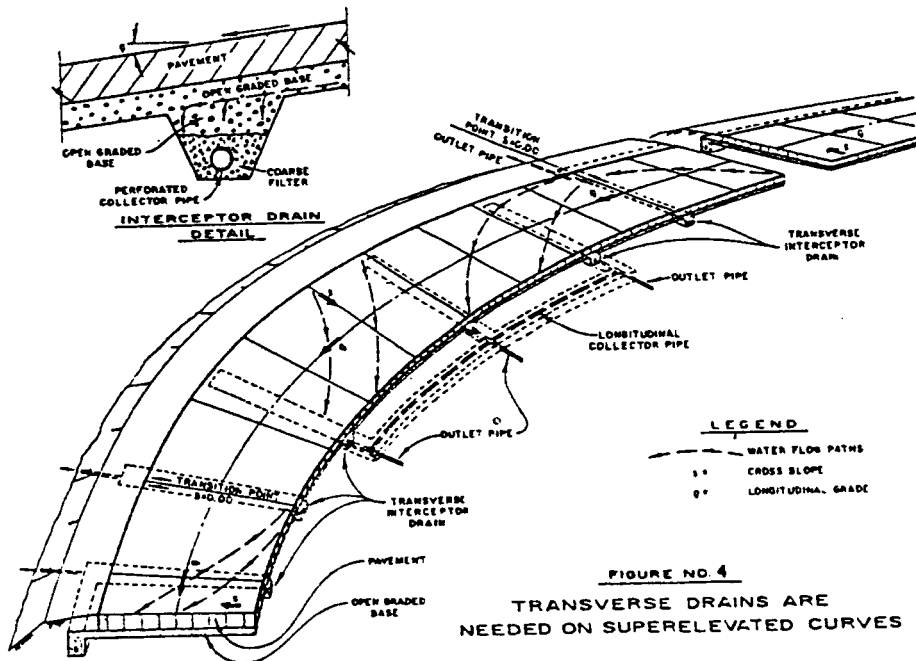

FIGURE NO. 4  
TRANSVERSE DRAINS ARE NEEDED ON SUPERELEVATED CURVES

system pipe be at least six inches higher than the maximum predicted water surface in the inlet to avoid storm water backing up into the subsurface drainage system. A procedure for calculating the maximum predicted water surface can be found in the "Road Surface Drainage Design, Construction and Maintenance Guide"(3).

Since six inch drainage and outlet pipes are suggested for convenience and operational safety margin, spacing of outlets will normally not be governed by the capacity of underdrains but by convenience to convey the water by the collection system to a suitable exit point. The location of outlets will often be dictated by topographic and geometric features and the overall drainage pattern adjacent to the highway. Nevertheless, as a general rule, the spacing of outlets should not exceed 500ft. These outlets generally should be placed at about a 45 degree angle from the direction of the flow in the longitudinal pipe lines.

### C.3 DESIGN OF THE SUBSURFACE DRAINAGE LAYER

The infiltration of water into the pavement has been practically resolved so as not to require the knowledge of the water movements, as will be shown in Section C.3.1 of this guide. The drainage layer developed by the NJDOT has the capacity to drain off the water in a reasonably short time and before it can cause jeopardy to the structural capacity of the pavements. As already indicated and shown on standard details, Figures 5 through 8, the drainage layer should be located immediately below the bound layer of a pavement under a minimum of 6 inches of confinement. Figures 5 and 7 give the cross-sectional view of a drainage layer, its edge drains, and a typical cross-drain for a generalized highway pavement. Figure 5 provides an alternate whereby the longitudinal

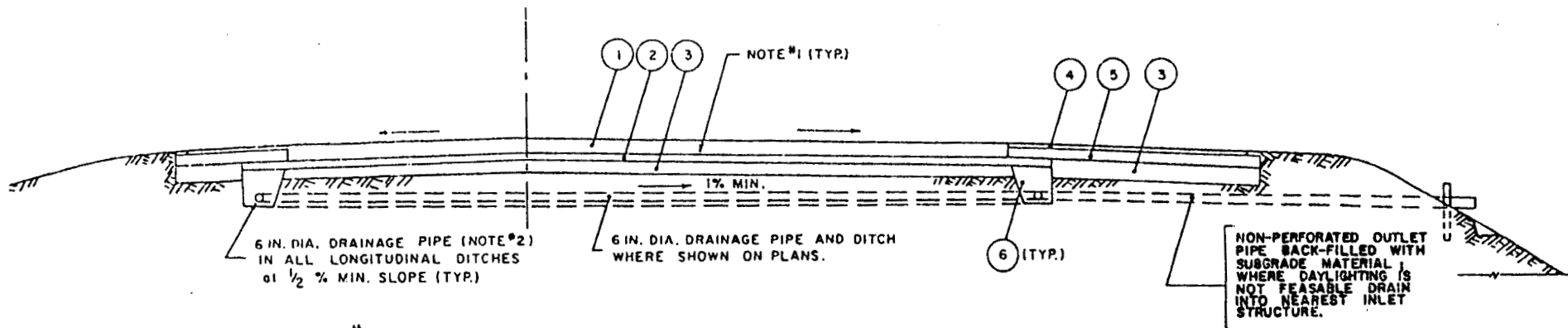

**FIGURE # 5 INTERNALLY DRAINABLE ROAD CROSS-SECTION WITH DRAINS AT THE EDGE OF PAVEMENT**

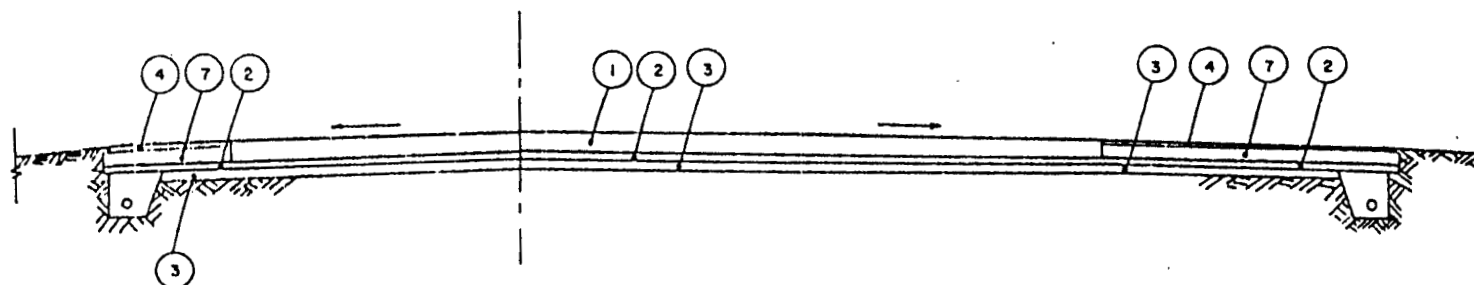

**FIGURE # 6 INTERNALLY DRAINABLE ROAD CROSS-SECTION WITH DRAINS AT THE EDGE OF SHOULDER**

- ① B.C. OR P.C.C. PAVEMENT, MIN. 6 IN. THICK
- ② 4 IN. B.S.O.G. OR N.S.O.G. DRAINAGE LAYER
- ③ BASE OR SUBBASE LAYER.
- ④ B.C. SHOULDER
- ⑤ SOIL AGGREGATE OR DENSE GRADED AGGREGATE BASE LAYER.
- ⑥ \*8 OR \*57 COURSE AGGREGATE
- ⑦ L.F.A. PLANT MIXED STABILIZED BASE COURSE OR NONSTABILIZED BASE COURSE OVER FILTER FABRIC.

NOTES 1. USE PRIME COAT ON THE TOP OF THE NSOG LAYER.

2. DRAINAGE PIPE SHALL BE PERFORATED OR SLOTTED CORRUGATED METAL, PVC OR PE PLASTIC OR POROUS WALL CONCRETE PIPES.

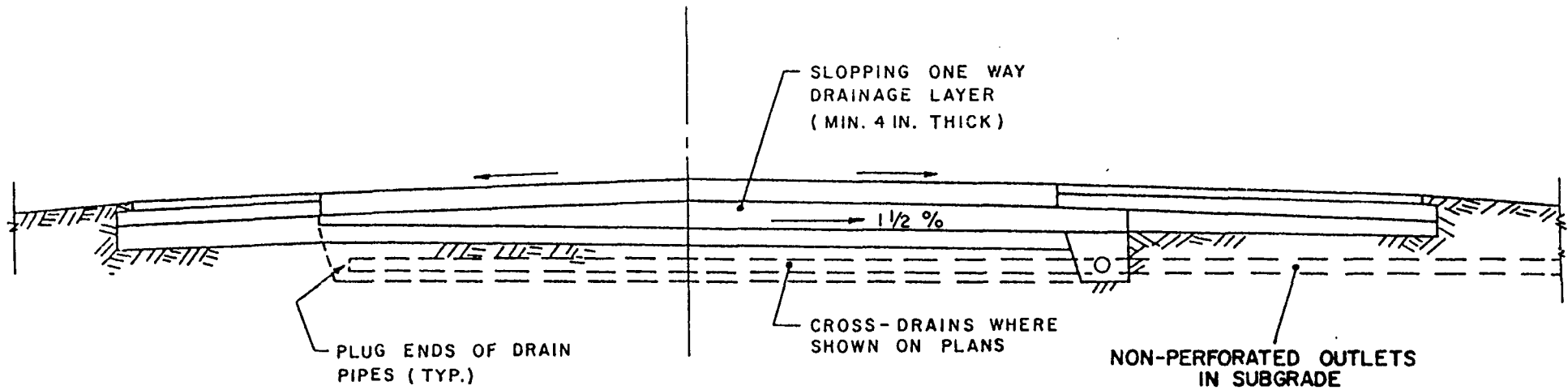

FIGURE #7 ROAD CROSS-SECTION DRAINABLE TO THE  
EDGE OF PAVEMENT COLLECTOR.

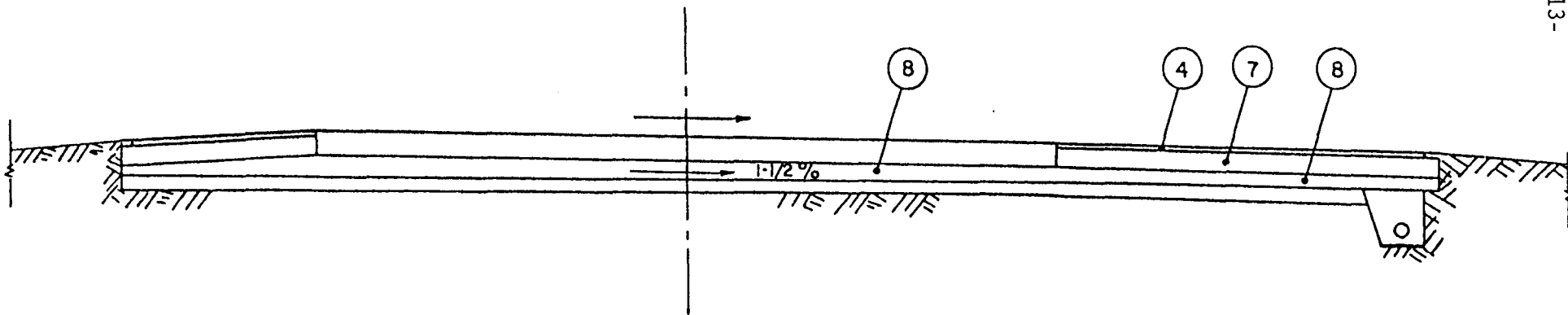

FIGURE #8 ROAD CROSS-SECTION DRAINABLE TO THE  
EDGE OF SHOULDER COLLECTOR.

NOTES : 1. LONGITUDINAL DRAINS IN THESE DETAILS CAN BE LOCATED AT EITHER THE EDGE OF PAVEMENT OR SHOULDER.

2. FOR ADDITIONAL DETAIL AND NOTES SEE FIGURES 7 AND 8

- ④ B.C. SHOULDER
- ⑦ NON-STABILIZED BASE COURSE OVER FILTER FABRIC OR STABILIZED BASE COURSE.
- ⑧ DRAINAGE LAYER, MIN. 4 IN. THICK.

edge drains are positioned at the edge of the pavement, while Figure 6 shows the same drains located at the edge of the shoulder. The Figure 6 alternate is preferred but if construction costs are of major concern, or if the design considerations require, the Figure 5 approach can be used. Figures 5 and 6 have the cross slopes and grade breaks of the drainage layer mirroring the pavement surface. Details in Figures 7 and 8 are basically duplicates of Figures 5 and 6 except that a constant cross slope is required of the drainage layer. From a long-term performance standpoint, construction in accordance with the Figures 7 and 8 details is best. However, for ease of construction but not necessarily for minimized installation costs, the configuration in Figures 5 and 6 will frequently be found more appropriate. Of course, variations of Figures 5 through 8 are entirely feasible as long as they are appropriately developed.

#### C.3.1 Water Infiltration and Principles of Subsurface Drainage

When surface water is not removed fast enough from the roadway area, it infiltrates the pavement section through the pores of the surface, joints, cracks, or potholes and, of course, from its sides. This means that a variety of parameters affect the infiltration process: the pavement's material, the material's quality, pavement age and location, climatic conditions and traffic conditions, just to mention a few. It would require a very large quantity of data to even approximate possible average amounts of surface water penetration. Therefore, an accurate method for determining the actual amount of penetrating water, in reality, is not available. However, as indicated in this author's report<sup>(6)</sup> an accurate determination of infiltrating quantities is not required in order to implement the drainage as proposed by this research.

Nevertheless, for information only, two well known methods of predicting infiltration should be mentioned here.

One proposed by H. R. Cedergren<sup>(4)</sup> recommends coefficients for "realistic infiltration intensity" of 0.5 to 0.67 for portland cement concrete pavements and 0.33 to 0.5 for bituminous concrete pavements. These coefficients multiplied by the rainfall intensity is said to yield good approximations of water influx to the base layer of a pavement.

Another method, offered by H. H. Ridgeway<sup>(5)</sup> suggests the following formulas for the amount of free water that will enter the pavement structure through its surface.

For portland cement concrete pavements:

$$Q = 0.1 (N + 1 + W/S) \quad (C4)$$

For bituminous concrete pavements:

$$Q = 0.1 (N + 1 + W/40) \quad (C5)$$

Where:

Q = the amount of infiltration in cubic feet per hour per linear foot of pavement,

0.1 = infiltration rate of 0.1 cubic foot per hour per foot of crack,

N = number of lanes,

W = pavement width in feet,

S = portland cement concrete slab length in feet, and

40 = average distance between transverse cracks in feet.

Besides the fact that Ridgeway's approach seemingly has no correlation to the rainfall intensity, when both his and Cedergren's approaches are used, there is no correlation between their infiltration rates. Although both authors indicate limited substantiations, in many respects discrepancies in both approaches are apparent. In essence, both methods appear to be quite arbitrary and reliance on them is considered ill-advised by the author.

The roof water drainage layer developed in this research is open enough to drain water in a reasonable amount of time, yet its flow is close to laminar. Also, this layer is dense enough to support traffic loads, while possessing filtration characteristics compatible with the base or subbase materials. Since there is no practical way penetration of roof water into pavements can be prevented, nor is it practical to drain this water any other way but horizontally, a drainage layer invariably should be used in all roads if the problems associated with water in pavements are to be solved.

As already indicated, the principles of subsurface drainage which have been adapted here, suggest that only the drainage capacity of the drainage layer determines the quantity of water to be drained. This quantity of water will generally be less than the capacity of the drainage pipes in the longitudinal edge drains. Therefore, the capacity of a drainage layer can then be calculated by Darcy's equation:

$$Q = KAi \quad (C6)$$

Where:

Q = discharge quantity in cu. ft./day per foot of longitudinal drainage pipe length

K = permeability constant in ft./day

$i = \frac{H_0}{L}$  = hydraulic gradient in ft./ft.

A = H x 1.0 cross-sectional area of drainage layer in sq. ft. per unit width of the layer

L = length of flowpath through the soil in ft.

H = thickness of O.G. layer in ft.

$H_0 = H + L \tan \alpha$  in ft.

$\tan \alpha$  = the slope of the base layer

The tabulations in Appendix A give flow quantities based on the Darcy equations for a variety of geometric conditions typically encountered with New Jersey highways. The total amount of water accumulated over any distance along the roadway is calculated by multiplying the tabular value by the distance between outlets.

The next parameter of importance is the time of drainage. To keep structural water damage at an absolute minimum, the total removal of water within a reasonable time span is desirable. If the amount of water to be drained is given by " $n_e AL$ " the Darcy fundamental equation, when solved for time " $t$ " then yields:

$$t_{\text{total}} = \frac{n_e L^2}{K (H + L \tan \alpha)} \quad (C7)$$

Where:

$t_{\text{total}}$  = time of total drainage of the moisture a layer can drain (in days), and

"effective porosity,  $n_e$ " =  $\frac{\text{volume of voids that can be drained}}{\text{Total volume}}$

Most investigators agree that the subsurface drainage must be capable of removing within a short enough time span 50% of moisture it can drain. This requirement prevents the freezing effect of the water from damaging the pavement structure. Using Casagrande's <sup>(7)</sup> flow equations for time, the 50% drainage point is expressed as follows:

$$t_{50} = \frac{n_e L^2}{2K (H + L \tan \alpha)} \quad (C8)$$

Where:

$t_{50}$  = time of drainage of 50% of the moisture a layer can drain  
(in days)

Effective porosity has been found to approximately equal 80% of the "absolute porosity  $n$ " for granular type materials.

As illustrated in Figure 9, using this formula and assuming  $n_e = 0.3$  and  $K = 1000$  ft./day arithmetically it can be shown that a 4 inch ( $H = 0.33$  feet) drainage layer sloping 1/2 to 10% with respective lengths of 66 to 670 feet can be sufficiently drained to remain hydraulically and structurally functional. In essence, the 50% drainage condition should be achievable for all the above conditions within the 24 hour period suggested by New Jersey's research when using the intended drainage layer design.

Considering, however, the limitations indicated elsewhere (6), caution is suggested in application of these drainage principles and a need for exercising engineering judgement in this design approach is also urged. With flow conditions of open-graded materials bordering on the turbulent, the flow rates will be lower than those predicted by Darcy's fundamental law. The magnitude of the flow rate in this instance would be a matter of conjecture as little work has been done in studying turbulent flow in soils. In any case, because of the possible turbulent conditions there needs to be a very stable grain structure in the drainage layer.

### C.3.2 General Types and Applications of Open-Graded Drainage Layer Materials

This research resulted in the development of two basic types of open-graded drainage material. The first, which consists of a plain stone blend is referred to as the non-stabilized, open graded (NSOG) material, and the second type,

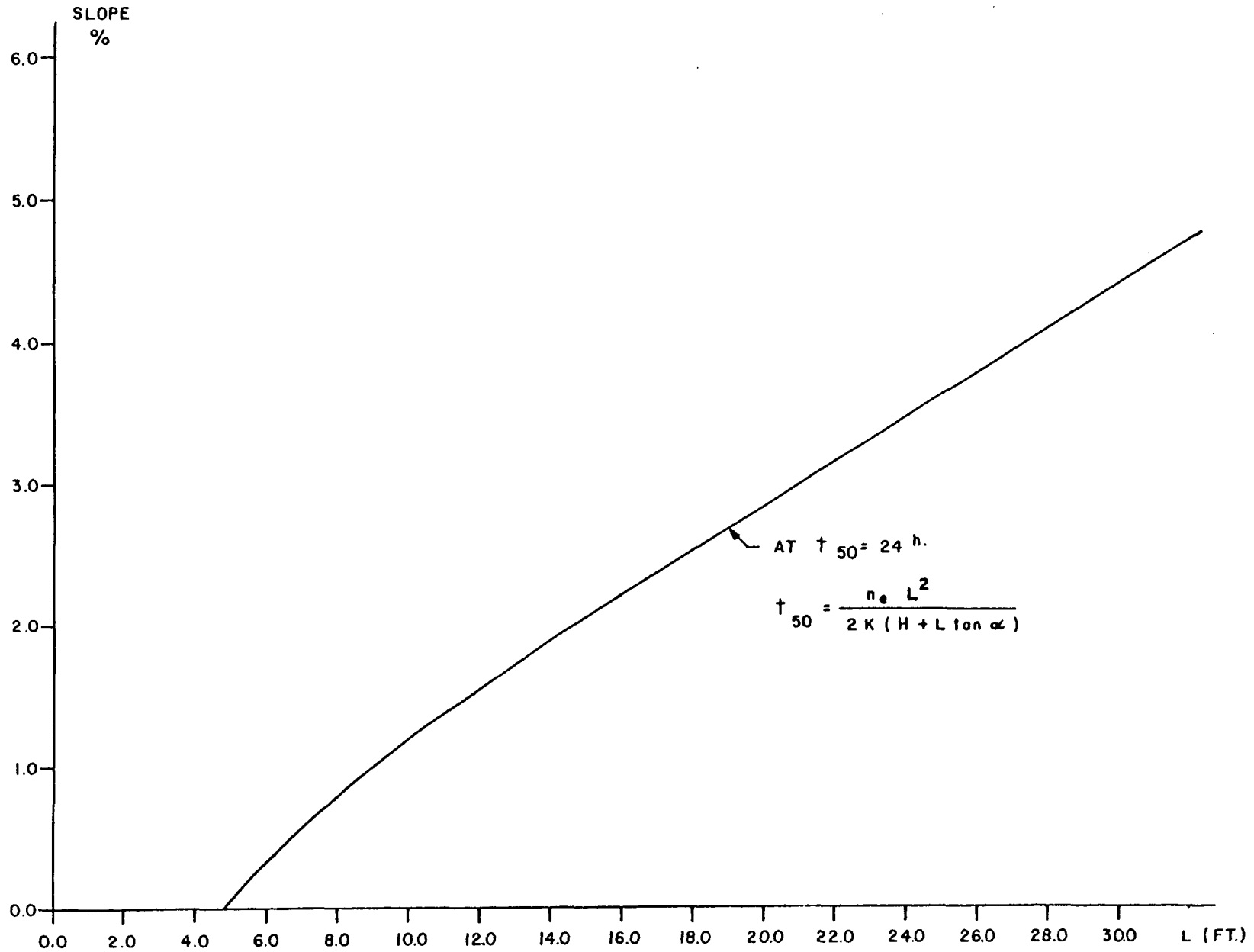

FIGURE #9 RELATION BETWEEN SLOPE AND LENGTH OF O.G. BASE FOR 50% DEGREE OF DRAINAGE.

which consists of a stone blend containing a small quantity of asphalt to enhance stability, is referred to as the bituminous stabilized open-graded (BSOG) material.

In any internal road drainage design either of the two types, the NSOG or the BSOG Layers, can be used with the appropriate collector system. Initially the NSOG material was developed primarily for use in rigid pavement designs, while the BSOG drainage layer was meant for use in flexible pavements. It was originally theorized that for the unbound NSOG material, rigid pavements would provide better, more uniform load distribution, while the BSOG layer with its stability provided by asphalt would be more compatible with the flexible pavements. Even though both drainage materials were used in full scale experiments, except for laboratory evaluation and scaled down test track modeling, no conclusive performance data are yet available. Thus far, the NSOG material has been found to be somewhat better from a structural performance standpoint. However, the BSOG is easier to construct. At the present time, it does not appear that there will be a great differential in cost between the two material types. For structural design purposes, both NSOG and BSOG can be assumed to have a structural index equivalent to NJDOT Dense Graded Aggregate Base SN = 0.14.

### C.3.3 Non-Stabilized Open-Graded Material Properties and Laboratory Test Procedures

The non-stabilized open-graded (NSOG) material must comply with the specification in Appendix B and the master gradation band shown in Figure 10. It can be made of a 50/50 blend of #57 and #9 stone specified in Table 1 or might be produced as a new standard size mix of coarse aggregates. If #57 and #9 stone are mixed, they must individually meet the grading specifications and be of the same source, i.e. stone type.

TABLE I. N.J.DOT STANDARD SIZES OF COARSE AGGREGATES.

Size Number	Nominal Size Square Openings (1)	Amounts finer than each laboratory sieve (square openings), percentage by weight															
		4	3½	3	2½	2	1½	1	¾	½	3/8	No. 4	No. 8	No. 16	No. 50	No. 100	
1	3½ to 1½	100	90-100		25-60		0-15		0-5								
2	2½ to 1½			100	90-100	35-70	0-15		0-5								
24	2½ to ¾			100	90-100		25-60		0-10	0-5							
3	2 to 1				100	90-100	35-70	0-15		0-5							
357	2 to No. 4				100	95-100		35-70		10-30		0-5					
4	1½ to ¾					100	90-100	20-55	0-15		0-5						
467	1½ to No. 4					100	95-100		35-70	10-30	0-5						
5	1 to ½						100	90-100	20-55	0-10	0-5						
56	1 to 3/8						100	90-100	40-75	15-35	0-15	0-5					
57	1 to No. 4						100	95-100		25-40		0-10	0-5				
6	¾ to 3/8							100	90-100	20-55	0-15	0-5					
67	¾ to No. 4							100	90-100		20-55	0-10	0-5				
68	¾ to No. 8							100	90-100		30-65	5-25	0-10	0-5			
7	½ to No. 4								100	90-100	40-70	0-15	0-5				
78	½ to No. 8								100	90-100	40-75	5-25	0-10	0-5			
8	3/8 to No. 8									100	85-100	10-30	0-10	0-5			
89	3/8 to No. 16									100	90-100	20-55	5-30	0-10	0-5		
9	No. 4 to No. 16										100	85-100	10-40	0-10	0-5		
10	No. 4 to 0 <sup>(2)</sup>											100	85-100				10-30

(1) In inches, except where otherwise indicated. Numbered sieves are those of the United States Standard Sieve Series.  
 (2) Screenings.

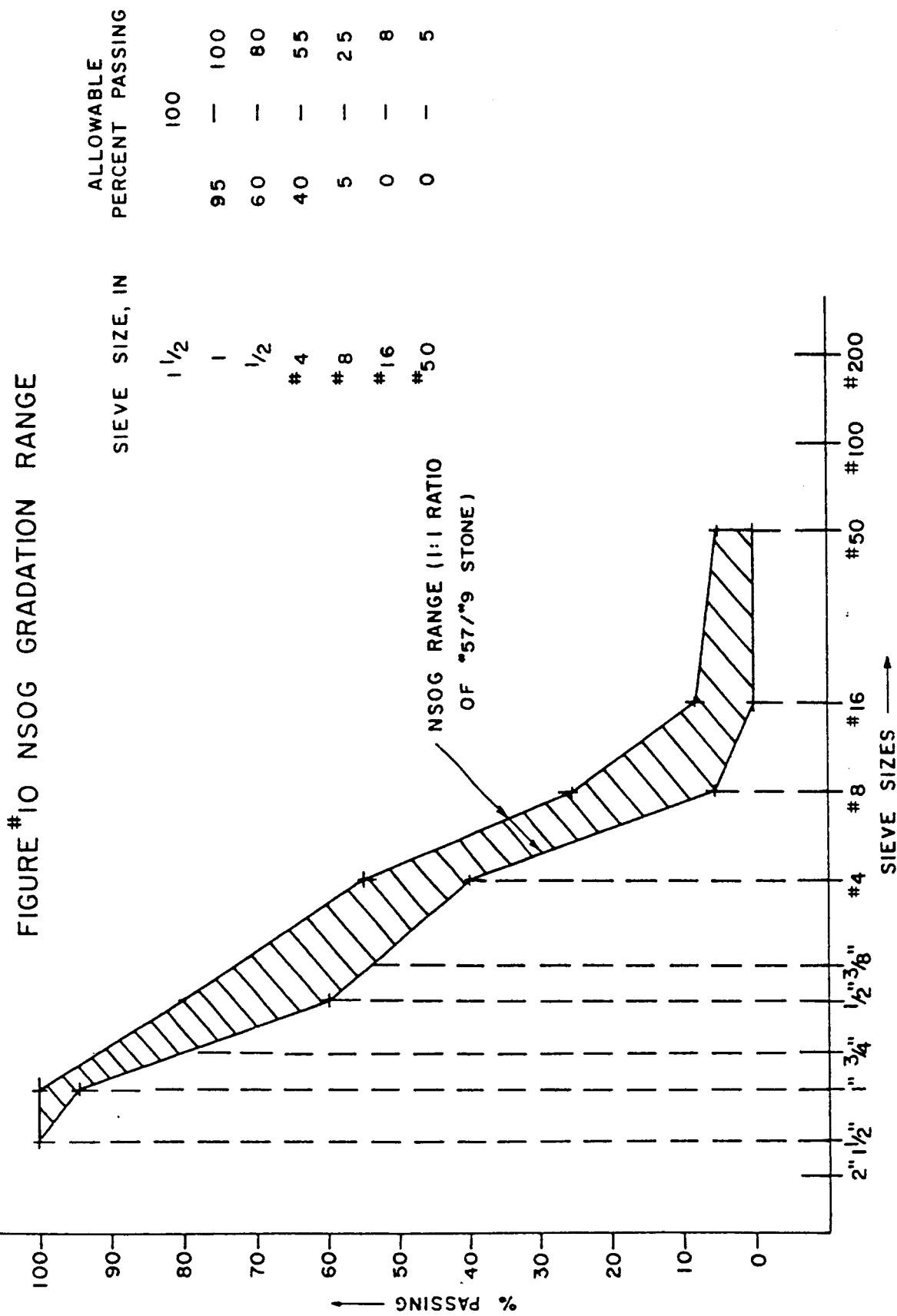

Even though only three specific stone sources were tested in this research, (one each for a limestone, trap rock and a gneiss source) these tested materials are representative of the predominant stone types available for NJDOT construction work. However, since these were not all inclusive tests and were laboratory rather than field investigations, caution is required when using crushed stone from other sources. There are many stone sources and even a few other stone types that are currently acceptable for state projects. To ensure that a particular stone type/source is suitable for NSOG material, the producer is required to submit for approval a particular target gradation that is within the band and can be produced with his aggregate sources. Samples of materials with this target gradation are then subjected to permeability testing and density and gradational stability evaluation with the Burmister vibratory table. To be acceptable the target gradation must provide a permeability in the range of 1000 to 3000 feet per day and a stable voids system. In this context gradational stability does not connote structural strength but rather it is based on visual aspects, i.e., absence of voids, degree of migration and segregation, hence a stable voids system. When a sample is compacted into Plexiglas molds it is visually evaluated for absence of voids and segregation, then density is measured directly in the mold.

To assure that adequate conditions are achieved in the field, in-place gradations are required to be close to the target gradation. The material's density in the field is monitored through "control strips" and hopefully will be close to that achieved in the Burmister mold in the laboratory.

To ascertain that the requirements indicated above and specified in the NSOG construction and material specification in Appendix B and in the NJDOT standard

specification Section 990 - Methods of Tests (8) are met, new falling head permeability and modified compaction tests are provided. The permeameter specified in Appendix C served well throughout the research study. The equipment can be used with confidence on materials having a "K" factor ranging from 100 to 20,000 feet per day. This permeameter gives reasonable repeatability, and the permeability constant "K" values are probably slightly conservative, hence applicable to the subject engineering problems. When used as a standard piece of testing equipment it should be improved and standardized for manufacturing purposes.

To duplicate field compaction conditions laboratory compaction procedures for NSOG material were developed and are also provided by the specification in Appendix D. ASTM specifications D-2049(9) provide Burmister Vibratory Table test procedures for compaction of cohesionless soils. As described in Appendix D, the Burmister equipment was modified for testing the open-graded materials. The modification consisted of using a Plexiglas mold to allow viewing of the samples for evaluation of their gradational stability and for density measurements. The relatively large plexiglas cylinder mold, capable of holding 15 lbs. of uncompacted NSOG materials, proved to be essential for obtaining representative density results. For permeability tests, a 4 inch metal mold is used with a 1600 gram specimen for compatibility with the permeameter. This equipment should also be standardized for manufacturing purposes.

It should be noted here that in our research wet NSOG stone consistently yielded densities which were lower than that of dry stone; the average difference amounting to approximately 8.5%. This was in spite of the fact that there appeared to be no migrations of the fine materials to the bottom of the

wet sample while considerable migration of fines could be observed in dry samples. Apparently, for typical NSOG gradations, water somehow decreases achievable density while lessening the migration of fines. Therefore, while wet stone will be used in the field to minimize segregation, in the laboratory, compaction tests only dry stone must be used. Since density and permeability are generally inversely related, if we use the procedure which yields the maximum density (i.e., dry stone) the associated laboratory estimates of permeability will be conservative.

#### C.3.4 Bituminous Stabilized Open-Graded Material Properties and Laboratory Test Procedures

The quality requirements for the Bituminous Stabilized Open-Graded (BSOG) material are specified in Appendix B. This material must comply with the master gradation band shown in Figure 11. This gradation, basically consists of #8 stone (see Table 1), modified by the addition of some large size aggregate to lower material cost. Since the material passing the #4 sieve and retained on the #8 sieve controls the permeability, the BSOG gradation specifications on the #4 sieve are also slightly more restrictive than that allowed for #8 aggregate.

The asphalt content for the BSOG material should always be set at 2 to 3% by weight of the dry aggregate and mineral filler. The lower limit of this range was determined on the basis of a thorough coating of the stone particles. The upper limit on the other hand was established as the asphalt content at which the excess begins to drain. Admixing of an anti-stripping agent to the asphalt is required for the field applications. Also, a small amount of mineral filler (2% by weight of the total mix) is used to stiffen the asphalt cement, to reduce asphalt drain off and to improve mixture cohesion.

FIGURE #11 BSOG GRADATION RANGE.

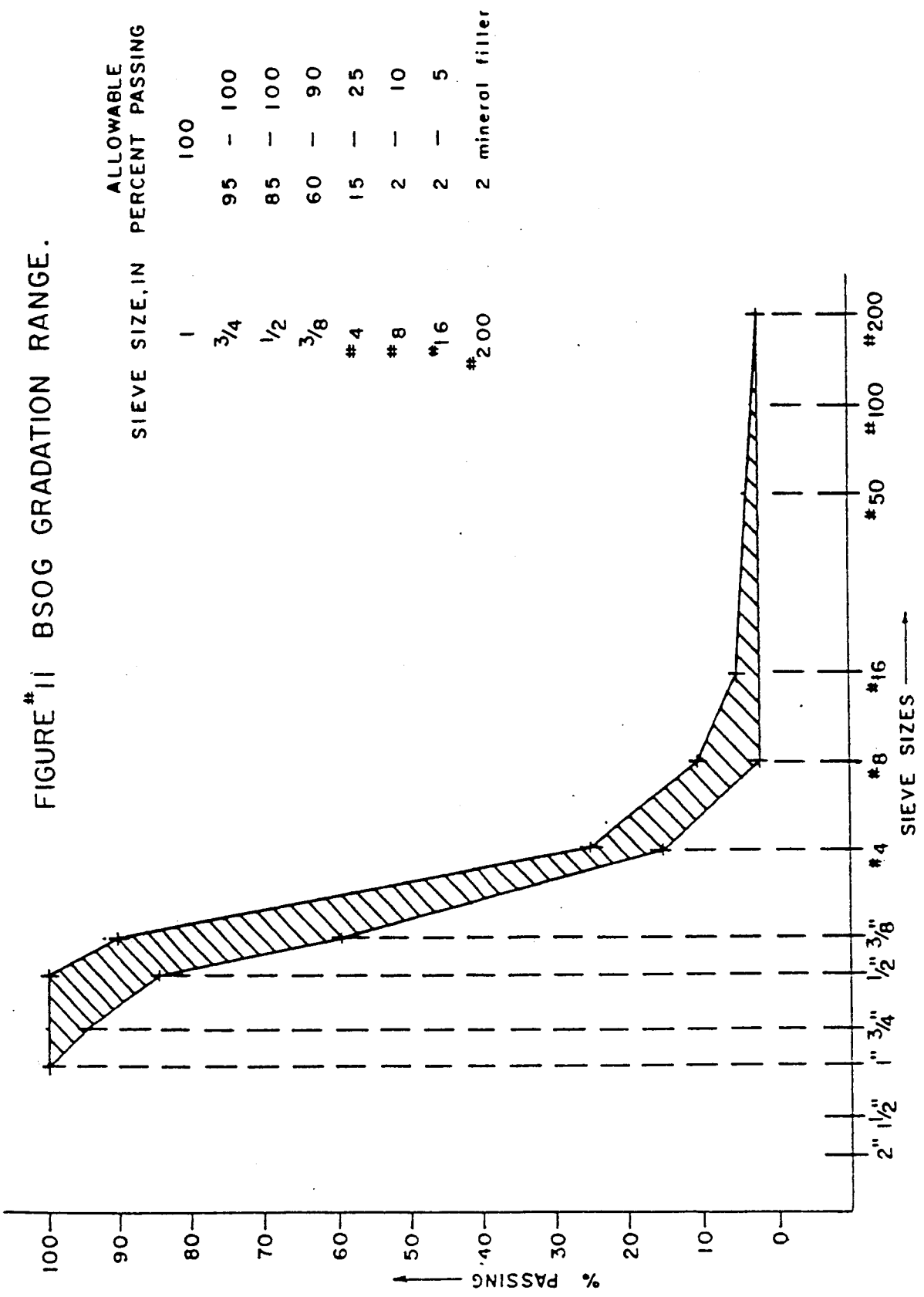

As in the case of the NSOG material, the contractor is required to submit for approval a particular target gradation, that is within the band. The design approval is based on NJDOT laboratory tests of mixture permeability. The compaction of the BSOG material is achieved with a Universal Testing Machine at pressures of 1000 psi for traprock and gneiss and 600 psi for limestone materials. This provides permeabilities within the required range of 1000 to 3000 ft. per day. Field permeabilities should be somewhat higher than the laboratory values since the compaction process with the Universal Testing Machine tends to create a more closed surface than that achieved in the field.

It should be recognized that the laboratory compaction data can serve as a guide for field densities. Since the laboratory compaction pressures evolved from an attempt to match achievable field densification, the laboratory densities could themselves be used as a rough indication of the probable field density. However, it could not be used as a target, since maximum density achieved on a control strip should be the only acceptable target. Nevertheless, a general equivalency between laboratory and the control strip field data offers some assurance that permeability levels in the field are somewhat comparable to the laboratory values.

To assure compliance with the requirements and the specifications indicated above, in Appendices C and D and in the NJDOT standard specification Section 990(8), permeability tests and modified Universal Testing Machine compaction procedures are provided. ASTM Specification D-1075(10), as used in the "Immersion Compression Test" was modified to suit the specific needs of BSOG material compaction. The major modification for testing drainage layer materials consisted of decreasing the compaction pressure specified in the test.

This was done to minimize the effect of the apparent crushing of particles, which had caused considerable changes in gradation, a phenomenon that did not occur in the field. After considering the density levels achieved in the field trials of the BSOG material and evaluating the degree of crushing occurring in the laboratory compression mode of compaction, a compaction pressure of 1000 psi was judged appropriate for traprock and gneiss aggregates and 600 psi for limestone aggregates. And again, since the researcher could examine only a limited number of New Jersey stone sources, caution must be exercised when new sources or types are being introduced.

### C.3.5 Barriers

For both the stabilized and non-stabilized open graded drainage layers, it is imperative that both materials are applied with some type of barrier, be it some form of soil stabilization, filter cloth, or filter type soils under, above and/or adjacent to the OG layer and drainage trenches. While the use of soil stabilization or filter fabric might increase the cost of drainable pavements, no additional cost should be incurred if materials compatible with filter requirements (such as the subbases typically specified for New Jersey roadways) are placed under the OG layer. In flexible pavement design, the use of LFA soil stabilization, if structural strength advantages were achieved, could provide considerable cost savings.

When used as a barrier, the filter fabric can serve two purposes: to line the drainage trenches and to provide a barrier between the conventional subbase and the open graded layers, as is exemplified in Figures 6 and 8. Both the polyester and the polypropylene fabrics have been used in experimental construction. The latter, however, only as a trench lining. While both materials seem to perform as claimed by the manufacturers the polypropylene fabric exhibited a

noticeable deterioration when exposed to the sunlight for a relatively short period of time.

When the lime-fly ash or the portland cement stabilized subbase is designed as a barrier, a three (3) inch thickness is sufficient. Since soil stabilization is incidental to this effort, it will only be briefly discussed here. More detailed information on this subject can be found in Appendix A of the Experimental Subsurface Drainage Application report (11).

There are two general methods for stabilizing road building materials: field mix and plant mix.

The field mix design should be used primarily when in situ soils must be stabilized. For example, during installations of groundwater drainage blankets, the subgrade soils often need to be stabilized to provide both a construction platform and a barrier between very fine soils of the subgrade and the very open drainage layer. The field stabilization method also can be selected for cost saving purposes. This method, however, has many drawbacks. Because of the difficulty in achieving good quality control, only 65 to 75% of the laboratory design strength development can be expected in a field stabilization mix. Severe dusting and the like problems are also commonplace in this construction procedure.

The plant mix alternate, while being more expensive, can provide 80 to 95% of the laboratory design strength because the quality controls are much easier to enforce and the construction is simpler and much more precise than in situ stabilization. Of course, only preselected materials, whether found on the site or fabricated, can be stabilized in this way.

The third type of barrier is the filter type soils, such as New Jersey base or subbase materials shown in Table 2. However, these soils, when used in conjunction with the OG layers, should never be applied on top of the layer without some other barrier. The purpose of Table 2 is to clarify classification of New Jersey base and subbase materials into the AASHTO and the Unified Systems and is taken from the report "Feasibility of Pavement Stabilization in New Jersey" (12).

Proof that filter type soils can provide effective barriers was obtained from the model test track experiments at the University of Illinois. Although a considerable infiltration of fines was established when testing drainage pavement designs suggested by others<sup>(13)</sup>, no infiltration of fines could be observed during tests on New Jersey's open graded pavement section<sup>(14, 15)</sup>. The major difference in these two experiments was that the Illinois researcher's design matched incompatible materials, i.e., very open drainage material against clayey soils, while New Jersey's drainage material is gradationally tight and the non-plastic granular matching base and subbase materials meet the filter requirements. Nevertheless, placing such filter materials on the top of New Jersey's OG layers is ill-advised, because there are enough fines (up to 5 to 12% passing #200 sieve that, given a chance, could contaminate the OG layer.

To satisfy this type of barrier requirement and thus to prevent infiltration and clogging of the OG layer the following relationships are suggested by Casagrande:

$$\frac{D_{15} \text{ (OG Base)}}{D_{85} \text{ (Subbase)}} \leq 5 \quad (C9)$$

Soil Aggregate	% Passing											
	I-1 (1-A)		I-2 (1-B)		I-3 (1-C)		I-4 (New)		I-5 (2-B)		Dense Grad Aggr. (5A)	
Sieve Size												
4"	100				100							
2"	70-100		100				100		100		100	
1"							60-100					
3/4"	50-95		65-100		60-100				70-100		55-90	
1/2"							40-100					
#4	30-60		40-75		30-100		25-100		30-80		25-60	
#8							20-100					
#16							15-85					
#50	5-25		5-30		5-35		8-45		10-35		5-25	
#200	0-7		0-7		0-5		5-10		5-12		3-12	
UNIFIED (ASTM)	-200		-200		-200		-200		-200		-200	
									<10% >10%		<10% >10%	
	<5%	>5%	<5%	>5%	<5%	>5%	<5%	>5%	<5%	>5%		
+ #4 > 50%	GW	GP	GW	GP	GW	GP	GW	GP	GW	GP	SM GC	GW GP GM GC
- #4 < 50%	SW	SP	SW	SP	SW	SP	SW	SP	SW	SP	SM SC	SW SP SM SC
AASHTO	A-1-a		A-1-b		A-1-b		A-3		A-1-b		A-1-b	
Max.LL	-		-		-		-		-		-	
Max.PI	6		6		6		N.P.		6		6	

TABLE 2

CLASSIFICATION OF NEW JERSEY BASE AND SUBBASE MATERIALS INTO THE AASHTO AND THE UNIFIED SYSTEMS

$$\frac{D_{50} \text{ (OG Base)}}{D_{50} \text{ (Subbase)}} \leq 25 \quad (\text{C10})$$

The compatibility of New Jersey's NSOG layer and the base and subbase materials listed in Table 3 and shown in Figure 12 is indicated in Tables 4 and 5. The data given in Table 5 show that New Jersey's NSOG material and normally specified New Jersey base and subbase materials are completely compatible. A compatibility comparison for the BSOG layer and base and subbase materials is not undertaken here since it would be merely an exercise. That is, the Casagrande formulas (Equations C9 and C10) were developed for soils and it is far from clear whether they would apply to bituminous modified samples.

For comparison, the test data listed in the Illinois report<sup>(13)</sup>, and on the attached Figure 13 can be analyzed as follows:

$$\frac{D_{15} \text{ OG layer (CA-7)}}{D_{85} \text{ clayey subgrade}} = \frac{5.82}{0.149} = 39.06 > 5$$

$$\frac{D_{15} \text{ OG layer (CA-14)}}{D_{85} \text{ clayey subgrade}} = \frac{5.30}{0.149} = 35.57 > 5$$

$$\frac{D_{50} \text{ OG layer (CA-7)}}{D_{50} \text{ clayey subgrade}} = \frac{11.2}{0.01} = 1120.0 > 25$$

$$\frac{D_{50} \text{ OG layer (CA-14)}}{D_{50} \text{ clayey subgrade}} = \frac{9.8}{0.01} = 980.0 > 25$$

TABLE #3  
GRADATIONS OF NSOG AND BASE AND SUBBASE MATERIALS

Designation Sieve Size	NSOG	1A	1B	1C	2B	5A
	Percentage by Weight Passing					
4"		100		100		
2½"						100
2"		70-100	100		100	
1½"	100					
1"	100-95					
¾"		50-95	65-100	60-100	70-100	55-90
½"	80-60					
#4	55-40	30-60	40-75	30-100	30-80	25-60
#8	25-5					
#16	8-0					
#50	5-0	5-25	5-30	5-35	10-35	5-25
#200		0-7	0-7	0-5	5-12	3-12

From the above it is apparent that the open graded layers and clayey subgrade materials used in the Illinois tests were, on the other hand, completely incompatible in terms of filtration characteristics.

Before concluding this discussion it is worth noting the condition analyzed above, i.e., very open drainage material placed directly on a subgrade, at times should be used for groundwater drainage conditions. However, to make such systems work, stabilization of the subgrade is essential. In conjunction with that, it should be noted that only lime stabilized subgrades (fine grained soils with the addition of lime) functioned adequately in the Illinois tests. Even filter cloths permitted infiltration of fines.

FIGURE # 12  
N.J. NSOG & BASE &  
SUB-BASE MATERIALS.

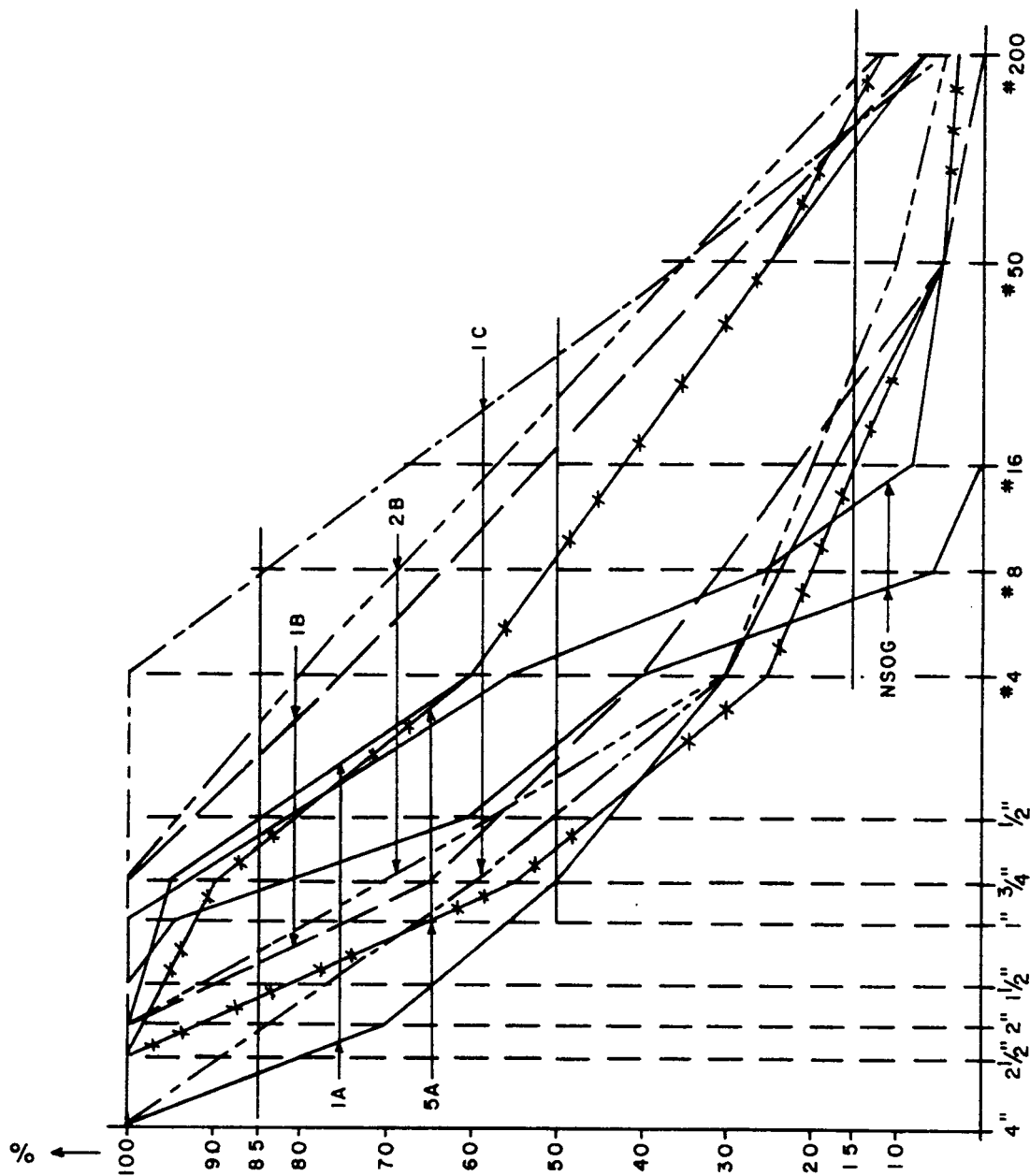

TABLE #4  
 NSOG AND BASE AND SUBBASE MATERIALS  
 GRADATION CHARACTERISTICS

GRADATION	D <sub>15</sub> (min) (mm)	D <sub>15</sub> (max) (mm)	D <sub>50</sub> (min) (mm)	D <sub>50</sub> (max) (mm)	D <sub>05</sub> (min) (mm)	D <sub>05</sub> (max) (mm)
NSOG	1.5	2.85	4.3	7.6		
1A			2.15	19.2	12.8	71.0
1B			1.3	8.4	8.3	33.5
1C			0.56	12.0	2.5	53.0
2B			0.74	9.4	6.6	31.0
5A			2.16	15.3	15.2	44.0

TABLE #5  
 NSOG TO BASE, SUBBASE MATERIALS FILTRATION CHARACTERISTICS

NSOG Base-Subbase	≤ 5				≤ 25			
	D <sub>15</sub> OG MAX D <sub>85</sub> MAX	D <sub>15</sub> OG MAX D <sub>85</sub> MIN	D <sub>15</sub> OG MIN D <sub>85</sub> MAX	D <sub>15</sub> OG MIN D <sub>85</sub> MIN	D <sub>50</sub> OG MAX D <sub>50</sub> MAX	D <sub>50</sub> OG MAX D <sub>50</sub> MIN	D <sub>50</sub> OG MIN D <sub>50</sub> MAX	D <sub>50</sub> OG MIN D <sub>50</sub> MIN
/1A	0.04	0.22	0.02	0.12	0.40	3.53	0.22	2.0
/1B	0.09	0.34	0.04	0.18	0.90	5.85	0.51	3.31
/1C	0.05	1.14	0.03	0.60	0.63	13.57	0.36	7.68
/2B	0.09	0.43	0.05	0.23	0.81	10.27	0.46	5.81
/5A	0.06	0.19	0.03	0.10	0.50	3.52	0.28	1.99

FIGURE #13  
BARENBERG'S TEST SITE

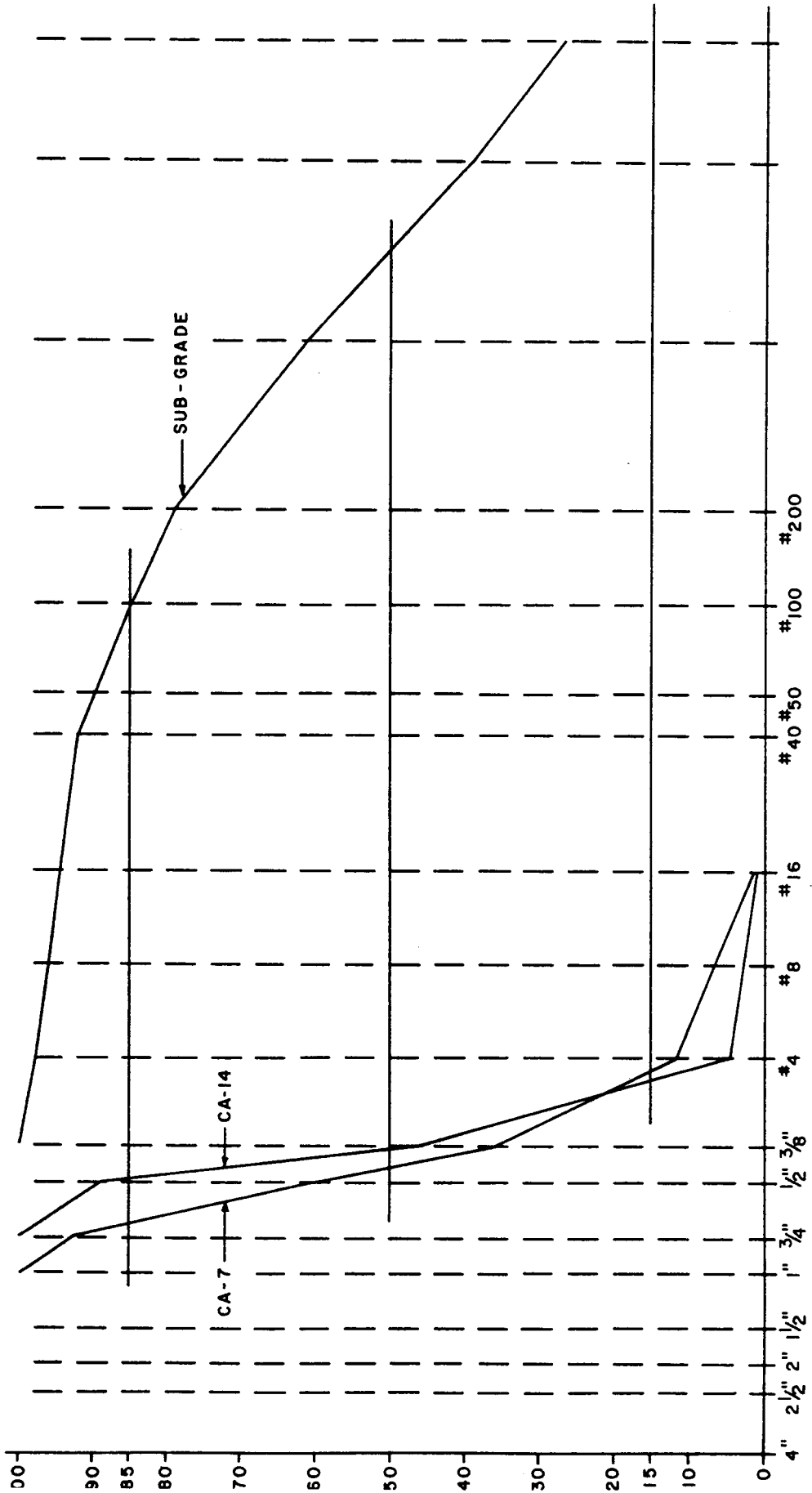

#### C.4 DESIGN OF WATER COLLECTION SYSTEMS

##### C.4.1 General

Some of the features of water collection systems were already discussed in the subsurface geometry analysis. Basically, physical features such as the use of longitudinal and/or transverse drains, the angle of outlets, daylighting or draining the outlets into the inlet structures and the like were discussed. The geometric analysis of the location, spacing and arrangement of collectors was also made.

At this point, two factors concerning internal drainage collection should be mentioned. One is vertical drainage, the other is daylighting of the drainage layer, instead of draining it into the edge drains. Vertical drainage of the infiltration water is impractical because of the impervious nature of the sub-base and the complexity and cost of the solution for determination of the subgrades drainage characteristics. On the other hand, the daylighting principle, at the glance, appears to be very tempting, mainly because it is so much cheaper. However, it is a generally well known fact that it is not uncommon for this type of outlet to become clogged and cease to function. This would mean a water buildup under the pavement resulting in a rapid deterioration of the permanent structure. Thus, a drain containing a pipe is the only positive mode of water collection that appears to be sufficiently practical and reliable.

##### C.4.2 Longitudinal and Transverse Collectors and Outlets

Figures 14 through 18 provide typical details of longitudinal and transverse collector designs and outlets which are either daylighted or terminated in inlets. Factors affecting collector design basically are drainability, suscep-

tibility to frost effects and structural integrity. Drainability is, of course, the purpose of such a system, however, frost or structural instability could jeopardize its functionality. It is for this reason that a collector must be carefully designed and constructed. As portrayed in Figures 14 and 15, the minimum requirements should be such that a 6 inch clearance is provided between the trench walls and the side of the pipe. Additionally, the trench must be deep enough to keep the bottom of the drain pipe on a 3 inch bedding, at least 12 inches below top of the subgrade and under minimum structural cover required by the pipe designs.

There seems to be a controversy concerning location of a drain pipe in relation to the frost depth. Theoretically, a functional pipe just is not going to have enough water to freeze. However, for reasons not fully substantiated, there are reports of frozen collectors impairing drainage functions. There are enough grounds to believe that situations might arise whereby collectors function might be impeded by frost. So the question is, how real a problem is the freezing of a collector system? This researcher believes that in lieu of adequate knowledge, the possibility of such a calamity calls for an engineering judgement and suggests that the requirements offered by Army Manual TM5-820-3<sup>(16)</sup> and shown in Figures 14 through 16 be used.

Since a drainage trench is located within a subgrade usually containing a large quantity of fines, a filtration medium such as a filter fabric lining is advisable, especially since the crushed stone trench backfill must have drainage characteristics exceeding that of the drainage layer material and particle sizes compatible with the pipe perforations. A #8 or #57 stone fits well into the situation, while the #57/#9 mixture has enough #9 stone size particles which might easily migrate into the pipe and permanently impede its function.

AT THE TIME OF DRAINAGE LAYER PLACEMENT REMOVE FABRIC FROM THE TOP OF TRENCH AND PLACE IT TO PROTECT EXPOSED EDGES AND THE TOP OF OPEN GRADED MATERIAL. (TYP.)

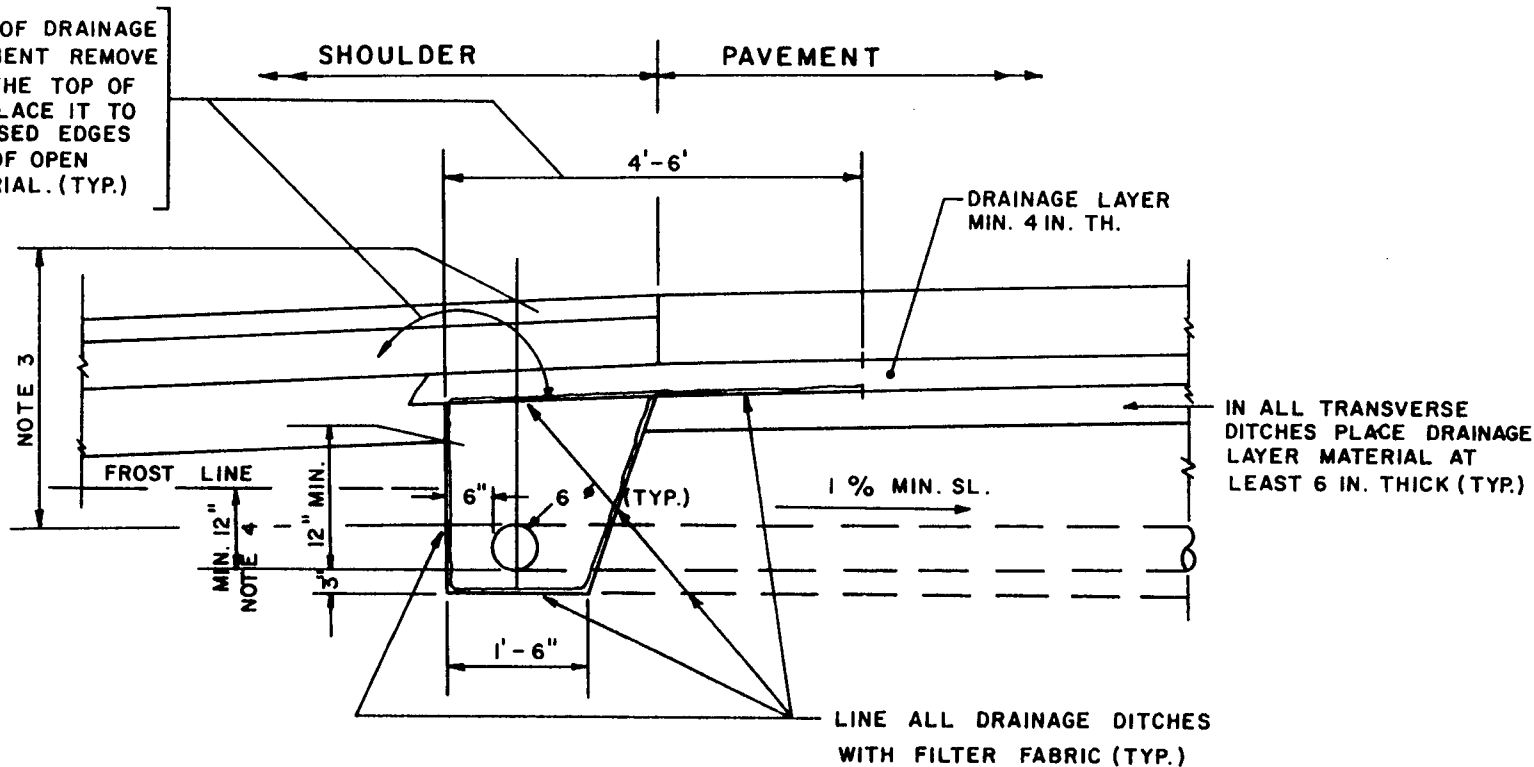

FIGURE #14 TYPICAL DETAIL OF THE EDGE OF PAVEMENT SUBSURFACE DRAINAGE COLLECTORS

NOTE: 3. FOR ALL TYPES OF PIPES TOTAL MIN. COVER SHALL BE 30 INCHES, BUT NO LESS THAN 12 INCHES OF SOIL SHALL BE PLACED ON TOP OF A PIPE. COMPACTION SHALL BE IN 6 INCH LIFTS BEGINNING WITH FIRST 12 INCHES OF MATERIAL PLACED OVER THE PIPE.

4. IF A SHALLOW COLLECTOR DRAIN IS DESIRED DISREGARD MIN. DEPTH BELOW THE FROST LINE.

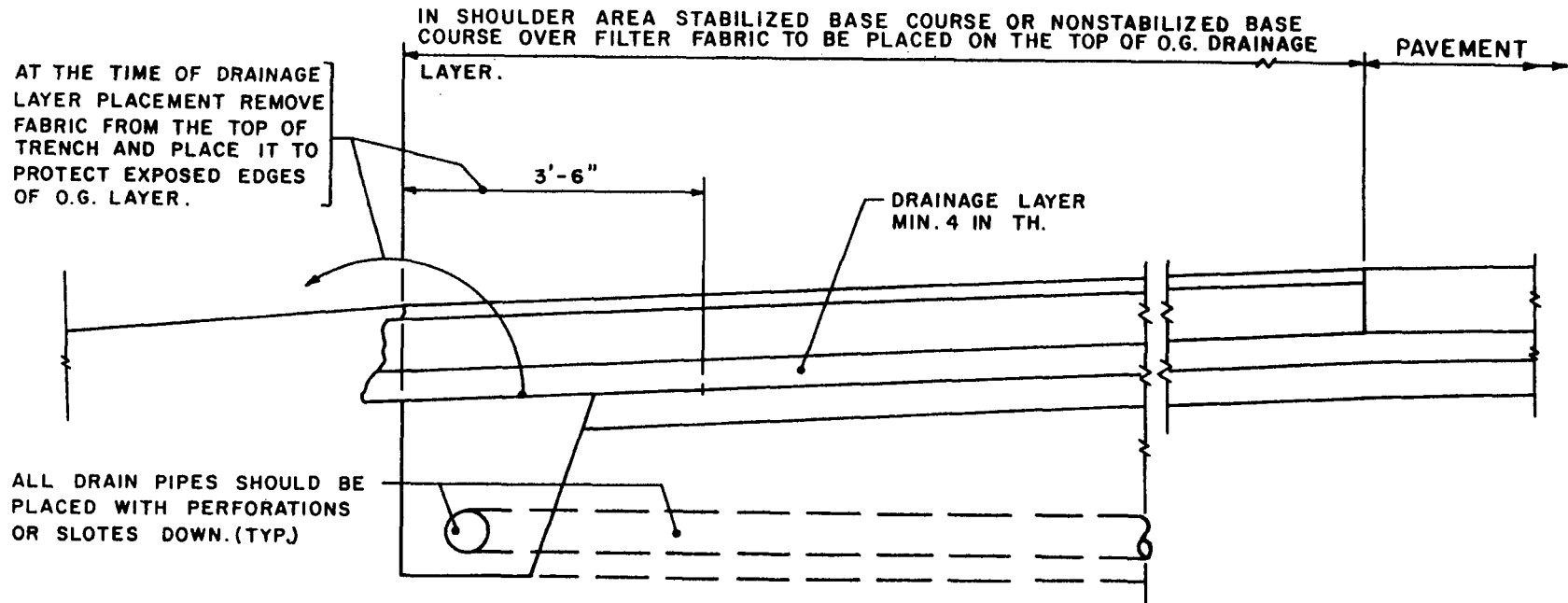

FIGURE #15 TYPICAL DETAIL OF THE EDGE OF SHOULDER SUBSURFACE DRAINAGE COLLECTORS.

NOTE: FOR ALL ADDITIONAL DETAILS AND NOTES SEE FIGURE #16

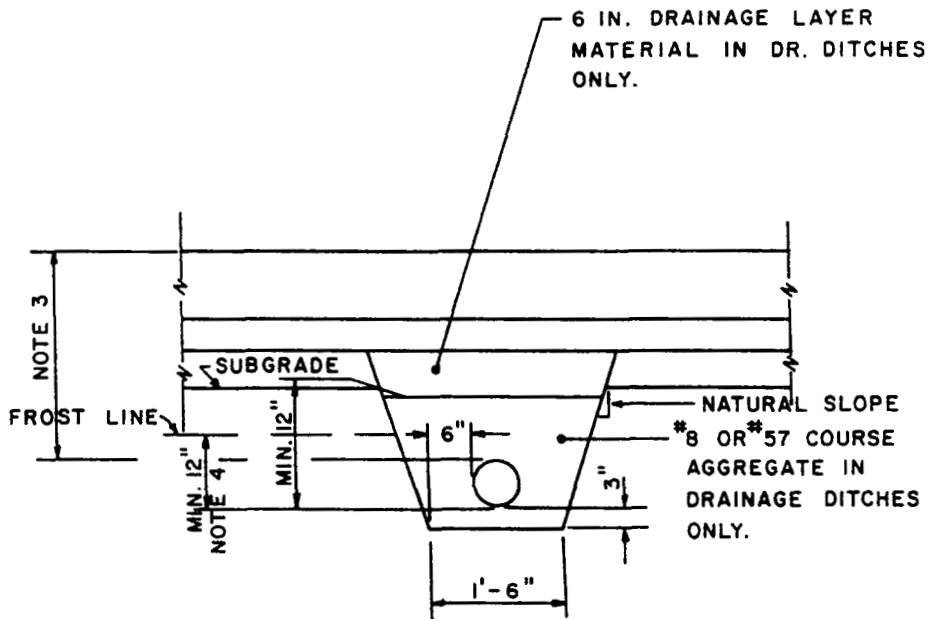

FIGURE #16 TYPICAL TRANSVERSE DITCH DETAIL

NOTE 3 FOR ALL TYPES OF PIPES TOTAL MIN. COVER SHALL BE 30 INCHES, BUT NO LESS THAN 12 INCHES OF SOIL SHALL BE PLACED ON TOP OF A PIPE. COMPACTION SHALL BE IN 6 INCH LIFTS BEGINNING WITH 12 INCHES OF MATERIAL PLACED OVER THE PIPE.

4. IF A SHALLOW COLLECTOR DRAIN IS DESIRED DESREGARD MIN. DEPTH BELOW THE FROST LINE.

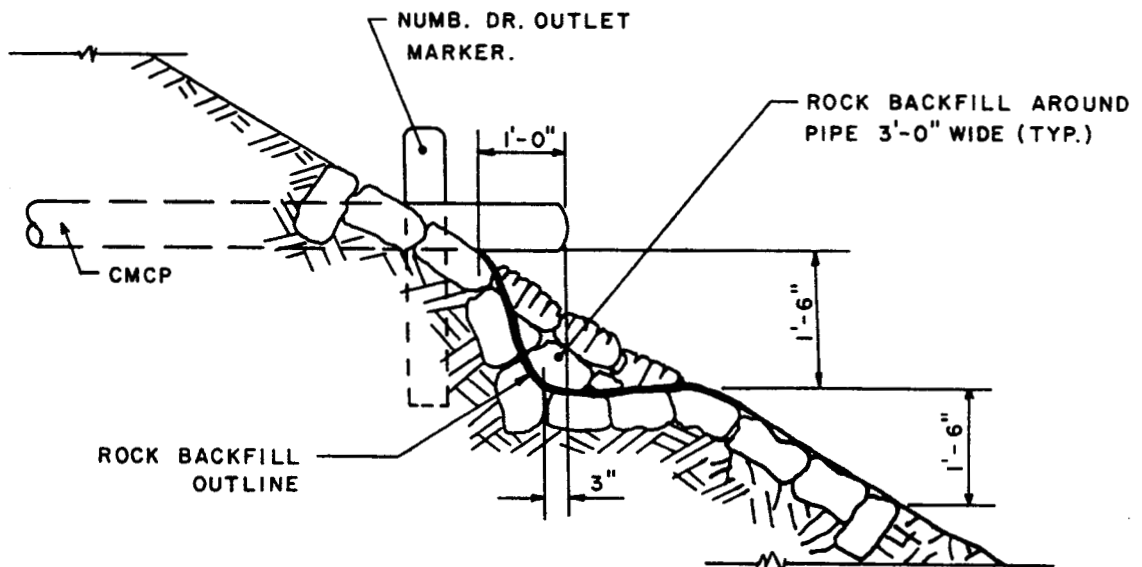

FIGURE #17 TYPICAL DETAIL OF DRAINAGE OUT-  
LET WITH ROCK BACKFILL

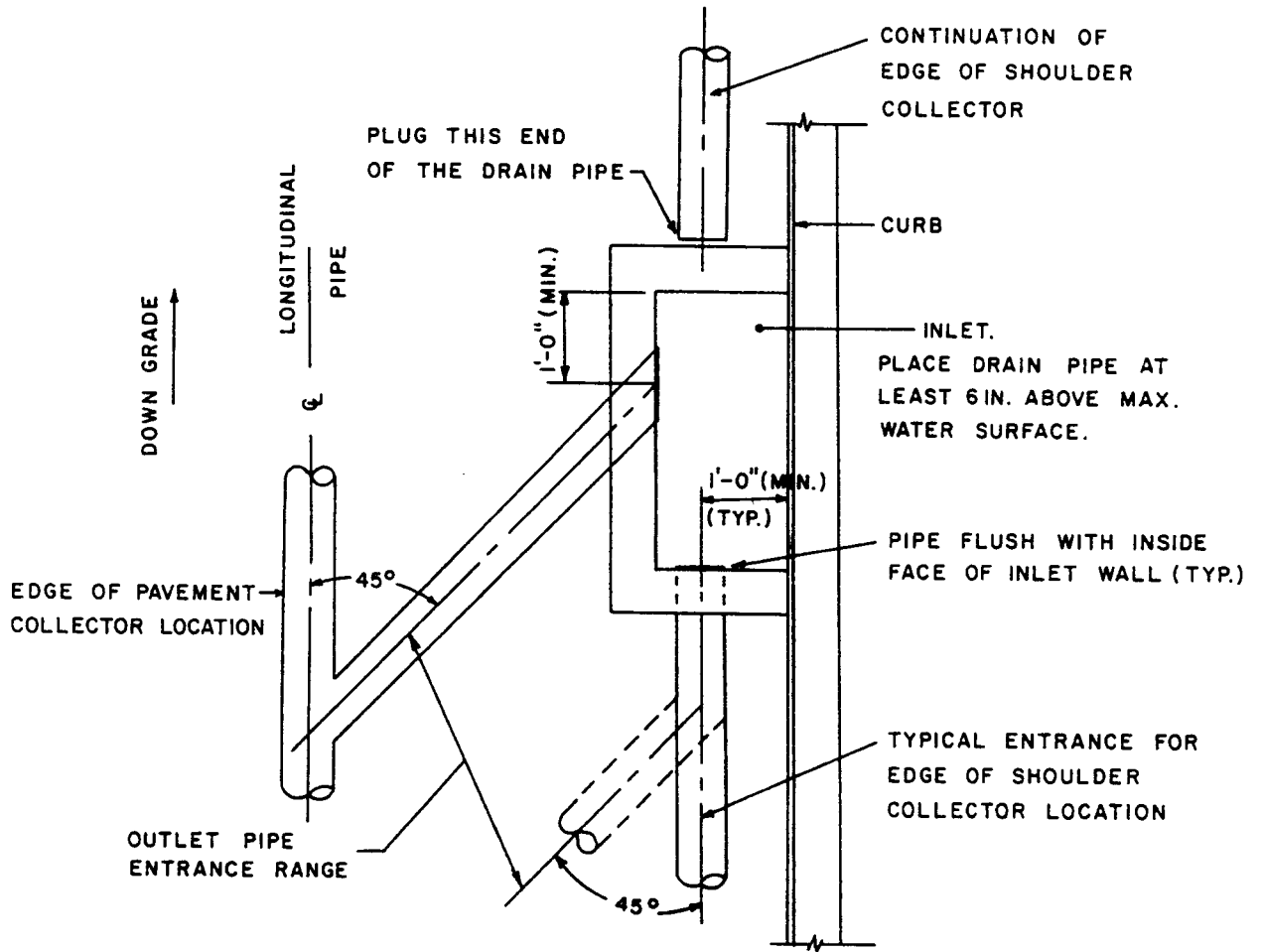

FIGURE #18 TYPICAL OUTLET PIPE ENTRANCE  
DETAIL.

According to an Army manual<sup>(17)</sup>, the respective filter criteria for prevention of soil migration into pipes with circular and slotted holes are:

$$\frac{D_{85} \text{ of filter material}}{\text{hole diameter}} > 1.0 \quad (C11)$$

$$\frac{D_{85} \text{ of filter material}}{\text{slot width}} > 1.2 \quad (C12)$$

Assuming 3/8 inch circular holes or 3/16 inch slots, the filter criteria for the subject stone sizes, shown in Table 6 indicate that the use of #9 stone in proximity of such perforated drainage pipes is simply ill-advised. While the #9 stone mix alone will definitely infiltrate a pipe, its combination with #57 stone theoretically satisfies the filtration requirements. Nevertheless, a mix consisting of 50% #9 stone and exposed to a turbulent flow might cause clogging of drain pipes. Thus only the #8 or #57 stone sizes should be used for back filling trenches.

TABLE 6  
EXAMPLES OF PIPE BACKFILL FILTER CRITERIA

Stone Sizes	$\frac{D_{85}}{\text{Hole dia}} > 1.0$		$\frac{D_{85}}{\text{slot width}} > 1.2$	
	Max.	Min.	Max.	Min.
#8	1.0	0.87	2.0	1.74
#9	0.5	0.42	1.0	0.84
#57	2.42	2.05	4.83	4.10
#57/#9	2.52	2.21	5.04	4.41

To protect the trench backfill from contamination by fines from adjacent soils a sufficient length of filter fabric flap should cover the trench during construction. This should be left in place until placement of drainage layer at which time the flap should be removed and placed to protect the edges of drainage material.

The same requirements and procedures are necessary for transverse ditches, except that to increase the structural integrity, the top 6 inches of the pipe backfill is replaced by regular (open graded) drainage layer material.

As Note #3 in Figures 16 through 18 indicates, porous wall, corrugated metal and PVC and PE plastic pipes can be used in such applications. While the first two types of pipe material have been used successfully for a long time, the use of plastic materials in such an application is relatively new.

At this point the importance of limiting the pipe bedding to only 3 inches and achieving good compaction of the pipe backfill must be mentioned.

Experience has shown that the use of more than 3 inches of bedding provides too much undrainable space below a drain pipe, and the structural strength, especially with plastic pipes, in large measure depends on the proper compaction of the backfill material. Improper handling of either criteria could impede the collectors structural integrity.

In August 1982, the cost per foot of 6 inch diameter drainage pipe delivered to the site on the average was: for steel pipe \$2.10, for porous concrete pipe \$1.60, for PE tubing \$0.60 and for PVC pipe \$0.80. Considering the cost of about \$13.00 per foot of drainage trench, complete with pipe and the backfill, the price of the pipe does not seem so critical and is of a lesser importance in the selection of the type of pipe.

TRB report 225<sup>(18)</sup> suggests caution in specifying plastic materials for drainage piping. The problem with plastics is that they are man-made materials and therefore, as in all other materials, manufacturing parameters govern the quality of the product. As TRB Report #225 states: "ASTM specifications contain requirements for structural properties of both the compounds used in pipe and the pipe itself. A review of these specifications shows that they do not provide positive assurance that buried (plastic) pipe products can meet even the most basic design criteria set forth herein. Furthermore, products meeting a given specification can possess significantly different and unknown structural properties. Finally, a product meeting the standard at the time of manufacture may be changed greatly by exposure to sunlight by the time it is installed."

The manufacturers of these products, however, since this TRB report was published in 1980, have been improving quality of their products as is reflected in the changes of the ASTM specification. At present, therefore, to provide the best suitable products for the purpose the specification in Appendix B are offered.

As already indicated, the standardized use of six inch drainage and outlet pipes is suggested for convenience and operational safety, that is, from an installation, functioning and maintenance point of view. However, if need be, the capacity of such pipes can be calculated using a common pipe flow (Manning's) formula under the condition of free surface flow in a pipe conduit. This is shown below and in the Figure 19.

The Manning formula for the capacity of a pipe running full is then:

$$Q = \frac{0.463}{n} d^{8/3} S^{1/2} \quad (C13)$$

Alternately the discharge capacity can be calculated as a product of a flow rate in a drain and the distance between outlets:

$$Q = q L \quad (C14)$$

where:

- Q = a pipe discharge capacity in cubic feet per second or cubic feet per day
- n = Manning's roughness factor
- d = pipe diameter in feet
- s = slope in feet per foot
- q = discharge quantity in cu. ft. per day per foot of drainage pipe length
- L = distance between outlets in feet

To facilitate computations of discharge capacity, the use of Figure 19 is suggested. This nomograph relates Manning's pipe flow equation to the product

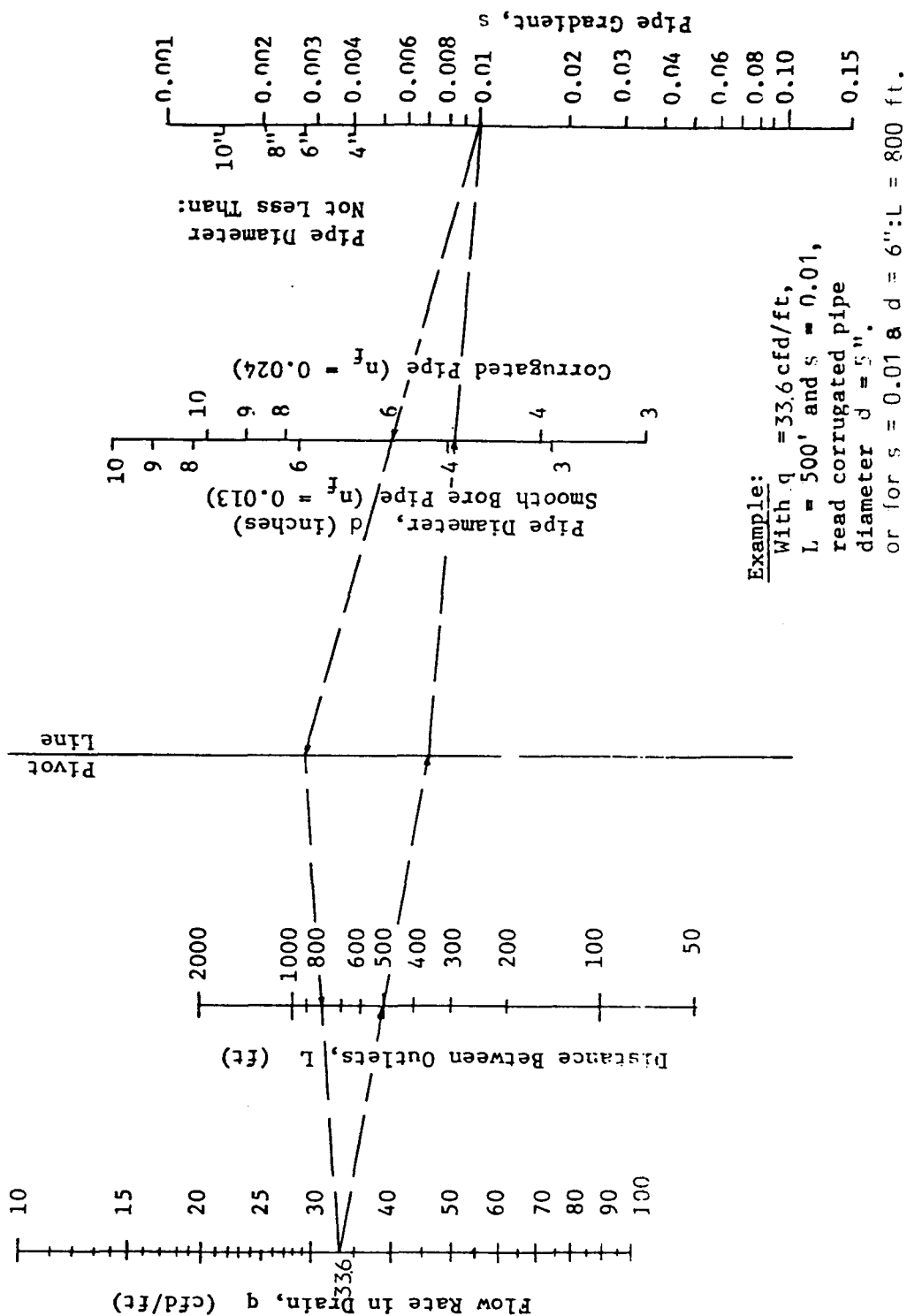

Figure 19. Nomograph Relating Collector Pipe Size with Flow Rate, Outlet Spacing and Pipe Gradient - Adapted From Cedergrren (1)

of a drain's flow rate and the distance between outlets. Figure 19 is based on studies of Cedergren et al<sup>(1)</sup> and Moulton<sup>(2)</sup>.

An example problem illustrating the use of the nomograph is presented in a later subsection. At this stage, suffice it to say that the drainage quantity "q" in essence is the flow rate of the open graded drainage layer as computed from equation C6. The total amount of water accumulated over a distance along the roadway is the total discharge quantity which should be less than or equal to the pipe discharge capacity "Q". The drain pipe discharge capacity "Q" could then be used to define the spacing of the outlets. However, since the author recommends the standardized use of 6" diameter drain and outlet pipes, in most installations the pipes will be oversized. Therefore, the spacing of outlets normally is not governed by the capacity of underdrains but by convenience in designing a collection system to convey the water to a suitable exit point.

Normally the outlet pipes should be daylighted, as is shown in Figure 17, but if this is not possible, then the water should be drained into the nearest inlet structure, as indicated in Figure 18. When latter is the case, it is imperative that the invert elevation of the subsurface drainage system pipe be at least six inches higher than the maximum predicted water surface in the inlet<sup>(3)</sup> to avoid storm water backing up into the Subsurface drainage system. The typical outlet pipe entrance detail shown in Figure 18 can accomodate an inlet structure location outside the line of the longitudinal collector drain (i.e. when the collector is placed at the edge of the pavement) or the inlets are located in line with the longitudinal collector (i.e. when an edge of shoulder collector is used). However, placing the longitudinal drains at the edge of a shoulder can, in this respect, cause a number of problems. First,

having an inlet structure in line with a collector will cause an interruption of the collector pipe, which in turn might cause water backup should a malfunction develop. A more severe problem might be encountered because of interference with various surface drainage pipes at the inlet structure. If a surface drainage pipe is in line with a subsurface drainage collector several questions need to be answered. In the first place, is it necessary to drain the shoulder? Are the costs of it critical? Is it worth the trouble? Standardization of the solutions to such problems will invariably cause difficulties during construction. Accordingly, if the shoulder has to be drained, a drainage collector can be placed at the edge of the pavement or in the shoulder so that at least two (2) feet of an impervious, undisturbed layer remains between the surface and subsurface systems. The shoulder drainage layer will have to be drained toward the trench. The other elements, such as a surface drainage pipe and like facilities might also be relocated so as to avoid interference with the drainage collection system. Finally, the surface drainage pipe could be lowered so as to provide about two (2) feet of an impervious layer between the top of the lower pipe and the bottom of the drainage collection trench. Especially in this case, the construction must be performed very carefully. Otherwise the drainage water is almost certain to leak into the lower trench. Then, a complete failure of the roadway might only be a question of time.

#### C.5 Subsurface Drainage Geometry Design Example

The experimental application of an internal drainage system on Route 195, Sections 6C and 7A is a good example of subsurface drainage geometry design, and is shown schematically in Figure 20. This section of roadway is located on a fill with a 1% grade and contains a portion of a vertical curve. To satisfy all

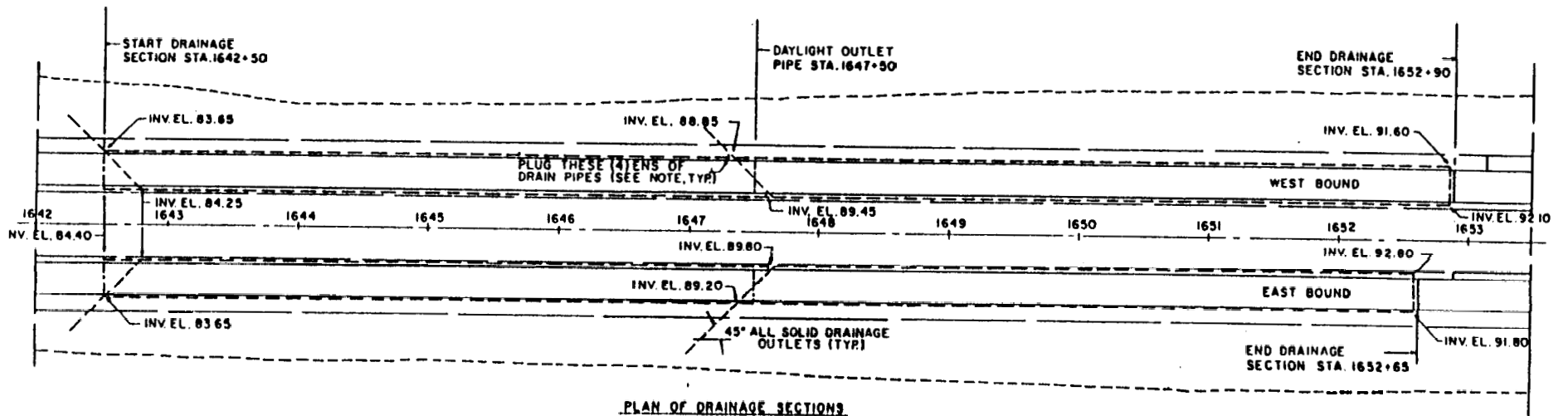

**PLAN OF DRAINAGE SECTIONS**  
 NOTE: NORMALLY DO NOT INTERRUPT DRAINAGE COLLECTORS' SYSTEM, CONTINUITY OF IT IS ESSENTIAL.

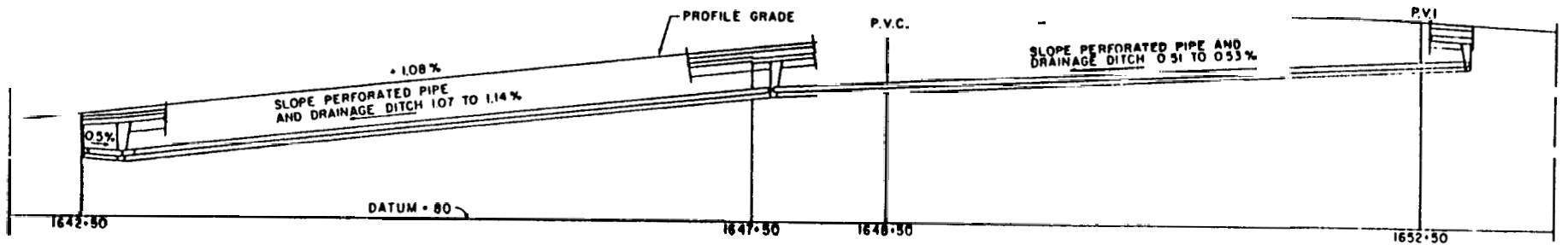

**DRAINAGE PROFILE**

**FIG. 20 ROUTE 195 SUBSURFACE DRAINAGE GEOMETRY DESIGN EXAMPLE**

requirements shown in the standard details provided in this guide, the drainage collectors and the inverts of outlet pipes are placed a minimum of 3 ft. below the top of the pavement. Also, the minimum requirement of 1/2% slope is satisfied under the vertical curve and for the return flow at the ends of the drain pipes. The elevations of the inverts are indicated to locate the collectors in such a way as to assure continuity of water flow into and out of outlet pipes. The continuity of a drainage collector system is essential to prevent damage that might occur, if an outlet malfunctions. For this reason, all inline outlets should be located so as to avoid the interruption of flow. In this case the outlets are daylighted on the fill slope as it is shown later in the standard details. The transverse drains at the start of the experimental section were used only to separate the test section from the rest of the road.

The location of the longitudinal collectors for this system demonstrates the need for designing the geometry of this type drainage for each project. As the standard details indicate, the location of such collectors should preferably be at the edges of the pavement or shoulders. However, as Figure 21 indicates, even though the edge of the pavement location was chosen for this design, the inside shoulder was only 5'-3" wide and did not warrant placement of the collector any other way but at the edge of the shoulder.

Such modifications have to be expected in a specific case. For example, on an experimental section of Route 676, the drains had to be located so as not to interfere with the placement of the PCC pavement or construction traffic. On the outside lane, the drain was placed under the shoulder, 1.5 foot from the pavement edge, whereas on the inside lane, the drain was constructed 0.5 foot inside the pavement edge. The point being that, in the design of the subsurface



drainage systems, the standards (such as the standard details provided herein) can be used, but only as guides for designing each individual drainage situation. However, by itself the roof water drainage approach offered in this guide has already been simplified by standardization, such as a 4 inch drainage blanket under a minimum of 6 inches of pavement surfacing, 6 inch collectors, preset gradations, etc. For the matter of fact, this drainable pavement design in general is so simplified that there is only limited engineering of each specific case required.

#### C.5.1 Internal Drainage Design Example

To illustrate the internal drainage principles developed by this research and the design procedures offered by this guide, the following design example is provided.

In this example the thickness of the drainage layer, the diameter of the drain collector and the spacing of the outlets will be checked for relatively severe rainfall and infiltration conditions.

Also, for this design, the physical data will be assumed to be the same as that for the Route I-195 experiment. The geometry and physical dimensions of that project are shown in figures 20 and 21. The drainage material is assumed to be an NSOG layer with a permeability constant of 1000 ft/day.

The design rainfall will be assumed to be the one year storm for N.J. (1.4 inch/hour maximum) the infiltration rate is expected to be 0.5. Therefore, the probable amount of infiltration can be calculated as:

$$q = \text{Area} \times \text{Infiltration Rate} \times \text{Rainfall} \quad (C15)$$

From Appendix "A", for a 12 ft. lane with 1 1/2% cross-slope and 12 ft. shoulder with 4% cross-slope, both sloping about 1% longitudinally, the maximum drainage path length, L, is 26.79 ft. Given the same parameters, a 4 inch NSOG drainage layer with a permeability constant K = 1000 ft./day has a discharge capacity Q = 13.5 cu. ft./day and a time of drainage, t = 4.70 hours. For a 1.0 ft. width of this drainage layer,

$$q = 24.00 \times 1.0 \times \frac{0.5 \times 1.4}{12} = 1.4 \text{ cu. ft./hour}$$

or

$$q = 1.4 \times 24 = 33.6 \text{ cu. ft./day} > 13.5 \text{ cu. ft./day.}$$

Therefore, about half way down the drainage path, the drainage layer will be running full, and the excess water, not being able to infiltrate the pavement structure, must be drained on the surface, i.e., where it should have been drained in the first place.

However, by increasing the thickness of the layer the capacity can be increased as follows:

$$q = K \times A \times i = 33.60 \text{ cu. ft./day}$$

From Appendix "A" at the same location the total head is:

$$H_0 = H + L \times \tan \alpha = 0.33 + L \times \tan \alpha = 1.10 \text{ ft.}$$

$$L \tan \alpha = 1.10 - 0.33 = 0.77 \text{ ft.}$$

or:

$$H_0 = H + 0.77;$$

and:

$$i = \frac{H_0}{L} = \frac{H + 0.77}{26.79} = \frac{H}{26.79} + 0.029;$$

Therefore:

$$q = 1000 \times H \times 1.0 \times \left( \frac{H}{26.79} + 0.029 \right) = 33.60$$

and the calculated drainage layer thickness  $H = 0.64$  ft. or approximately 7.5 inches.

The next step is to determine the pipe size needed for the system or alternatively the discharge capacity of the standardized 6 inch pipe can be established. The nomograph on Figure 21 can provide both answers.

In the first case, starting from the left side of the nomograph at the "flow rate in a drain  $q$  (cfd/ft.)" going through the "distance between outlets"  $L = 500$  ft. a pipe discharge capacity  $Q = qL$  can be established at the "pivot line". By connecting this point with the pipe gradient  $S = 0.01$  the corrugated pipe diameter "d" can be read. For a 7.5 inch thick drainage layer, an approximately 5 inch diameter pipe with a 500 ft. outlet spacing would suffice.

Starting from the same 1% "pipe gradient" and the 6 inch" corrugated pipe", for the same 7.5 inch drainage layer, an 800 ft. outlet spacing would be adequate.

#### D. DESIGN OF GROUND WATER DRAINAGE

##### D.1 GENERAL

The analysis and solutions of the ground water drainage problems offered here are adapted from Professor Lyle K. Moulton's publication "Highway Subdrainage Design"(2). At times verbatim excerpts are used.

A ground water control system refers to subsurface drainage specifically designed to remove or control the flow of groundwater. Such a subsurface drainage system may perform a number of the following functions:

1. Intercept or cutoff the seepage above an impervious boundary; and
2. draw-down or lower the water table.

Often such a system may apply to more than one function, such as the interceptor drain which not only cuts off the flow but also draws down the water table. Such subdrainage systems are commonly identified in terms of their location and geometry. Unlike infiltration water drainage systems -- which should be used as a standard feature on all new construction, -- a groundwater drainage system is to be used only when and where it is needed. This means it must be designed to fit each case individually and in the most cases it will consist of some form of interceptor. Furthermore, the quantity of flow and the means of its disposal must be known for a ground water drainage system to be adequately functional.

In most cases, little or no water gets into the pavement section from this source. However, in cases where ground water does enter the pavement (e.g. as a result of high water table or artesian flow) the necessary water drawdown often can be accomplished by a properly designed drainage blanket of high permeability. Normally, such drainage blankets are located beneath the subbase on the top of the subgrade so as to keep water from saturating the pavement foundation. This layer, in contrast to a drainage layer for the removal of roof water, must be designed and constructed so as to remove all water as soon as it is reasonably possible. The reader will recall that for roofwater drainage,

such rapid removal of water would be detrimental since, a) the possible associated turbulent flow could disrupt the system and b) the gradation of the drainage layer would have to be so open as to create problems in load carrying capacities.

#### D. 2 CLASSIFICATION OF THE HIGHWAY GROUNDWATER SUBDRAINS

The most common way of identifying ground water subdrainage systems is by their location and geometry and can be summarized as follows:

1. The longitudinal drains, located essentially parallel to the roadway centerline both in horizontal and vertical alignment. They may involve a trench of substantial depth, collector pipe and a protective filter of some kind.

2. The transverse and horizontal drains running laterally beneath the roadway and normally located at some angle to the roadway centerline. Such drains also involve a trench, collector pipe and protective filter. When the general direction of the ground water flow tends to be parallel to the roadway (when the road is cut perpendicular to the existing conditions), the transverse drains can be more effective than longitudinal drains. The horizontal drains consist of nearly horizontal pipes drilled into cut slopes or sidehill fills to tap springs and relieve porewater pressure.

3. The drainage blanket is a very permeable drainage layer used exclusively for removal of the ground water from gravity and artesian sources. Since all water must be removed quickly, the requirements must be to use an adequate thickness of material with a very high coefficient of permeability. Further requirements are a positive outlet for the water and the use of one or more protective filter layers and/or stabilized barrier underneath the blanket to protect it from contamination by fines.

4. The well systems or vertical wells can be used to control the flow of ground water and to relieve pore water pressures. They may be pumped to temporarily lower the water table during construction. Often they are provided with some sort of collection system so that they are freely drained at their bottom.

5. Frequently, during the course of highway construction and maintenance, local seepage conditions are encountered which require subsurface drainage to remove the excess moisture or relieve porewater pressures. Such conditions may require a drainage blanket with pipe outlets, longitudinal or transverse drains or some combination of these systems.

When intercepting the flow of ground water or drawing down the free water surface is not readily possible, it will be necessary to include seepage from this source when designing pavement drainage. Two possible sources of ground water, already mentioned, should be considered:

1. Gravity drainage shown in Figure 22 and
2. Artesian flow illustrated in Figure 23.

In either case, the average inflow rate can be estimated by means of a flow net analysis or by use of rational analytical methods. While these methods yield only approximate solutions, they are deemed adequate for the purpose and are adopted for use in this guide. To further simplify the analysis of groundwater problems, a number of graphical design aids have been prepared which can be readily applied by the highway engineer. The approach adopted here is fully discussed in Professor Moulton's report<sup>(2)</sup>, however, only the basic information is presented in this guide.

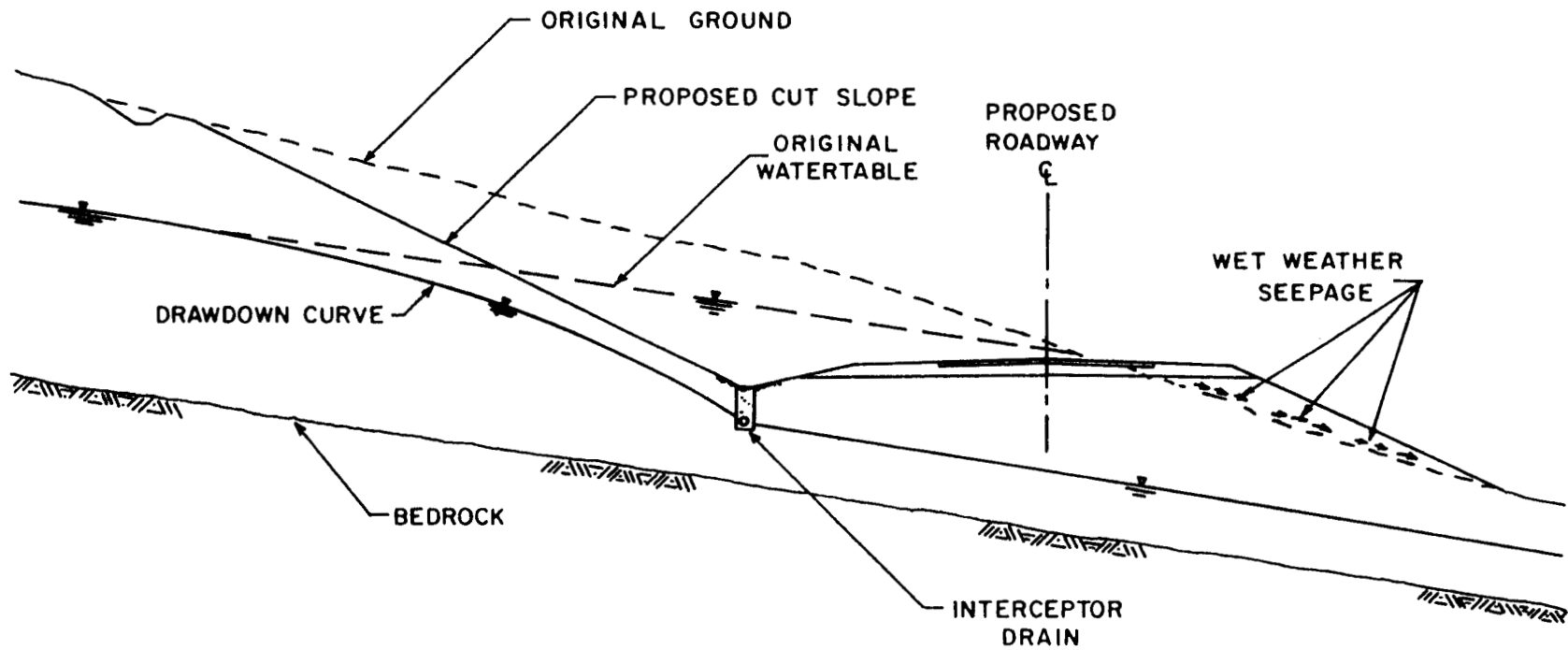

FIGURE #22. LONGITUDINAL INTERCEPTOR DRAIN USE TO CUT OFF SEEPAGE AND LOWER THE GROUNDWATER TABLE.

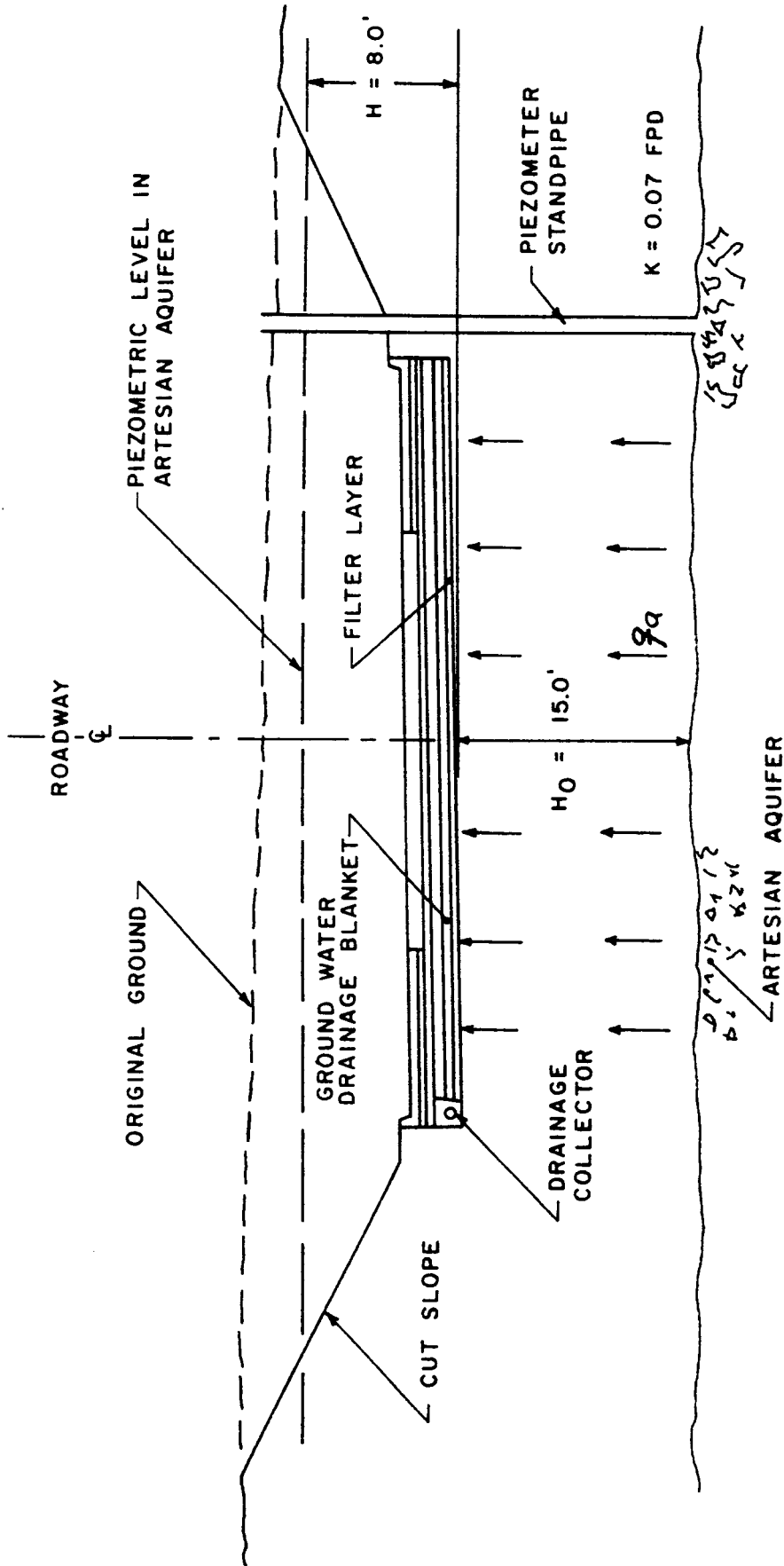

FIGURE # 23. ARTESIAN FLOW OF GROUNDWATER INTO  
A PAVEMENT DRAINAGE LAYER.

### D.3 THE DESIGN ANALYSIS

The analysis of the protective filter layers or stabilized barriers as well as the design of the drainage blanket or the collector systems have been already discussed in the preceeding sections on internal drainage design.

The use of the soil stabilization barriers most likely would provide not only the necessary protection for the highly open drainage layers used in solving groundwater problems, but also could provide a good construction platform, if proper construction procedures were applied.

As to the design of a ground water drainage blanket, since the permeability requirements are bound to change with the changes of the available water quantities, a different and considerably simpler approach could probably be used. In essence, various readily available crushed stone aggregates could be classified by their probable permeabilities. Using the Darcy flow formula and knowing the gradient of the drainage, an appropriate combination of the blanket thickness and the materials with acceptable permeabilities could be then selected. Regretably, however, no such classification of available New Jersey materials was performed because no ground water drainage research was undertaken in this study.

### D.4 BASICS OF THE RATIONAL ANALYTICAL METHODS

Frequently, it is possible to intercept the flow of ground water and/or draw down the free water surface so that little or no water gets into the pavement section from this source. However, under some circumstances, it may not be possible to control the flow of ground water in this way, and it will be necessary to include seepage from this source in designing pavement drainage.

Two possible sources of groundwater should be considered: (a) gravity drainage, and (b) artesian flow.

For the case of gravity drainage, the average inflow rate,  $q_g$ , can be estimated by the use of Figure 24, which was prepared to facilitate approximate computations of this type. In either case, the first step will be the determination of the "radius of influence" or drawdown influence distance, which can be estimated, for practical purposes, by means of the expression

$$L_i = 3.8 (H - H_0), \quad (D1)$$

where:

$L_i$  is the influence distance (feet) and  
 $(H - H_0)$  is the amount of drawdown (feet).

Once the value of  $L_i$  has been determined, Figure 24 can be used to determine the total quantity of upward flow,  $q_2$ , into the drainage blanket. The average inflow rate can then be computed from the relationship:

$$q_g = \frac{q_2}{0.5W}, \quad (D2)$$

where:

$q_g$  is the design inflow rate from gravity drainage (cubic feet/day/  
square foot of drainage layer)  
 $q_2$  is the total upward flow into one half of the drainage blanket  
(cubic feet/day/linear foot of roadway) and  
 $W$  is the width of the drainage layer (feet).

Although the solution given in Figure 24 is based upon a symmetrical configuration of gravity flow, very little error is introduced if the flow conditions are not exactly symmetrical because of roadway cross slope, variation in depth of the impervious boundary, etc. Under these conditions, the use of average values of  $H$ ,  $H_0$  and  $L_i$  in Figure 24 will be satisfactory.

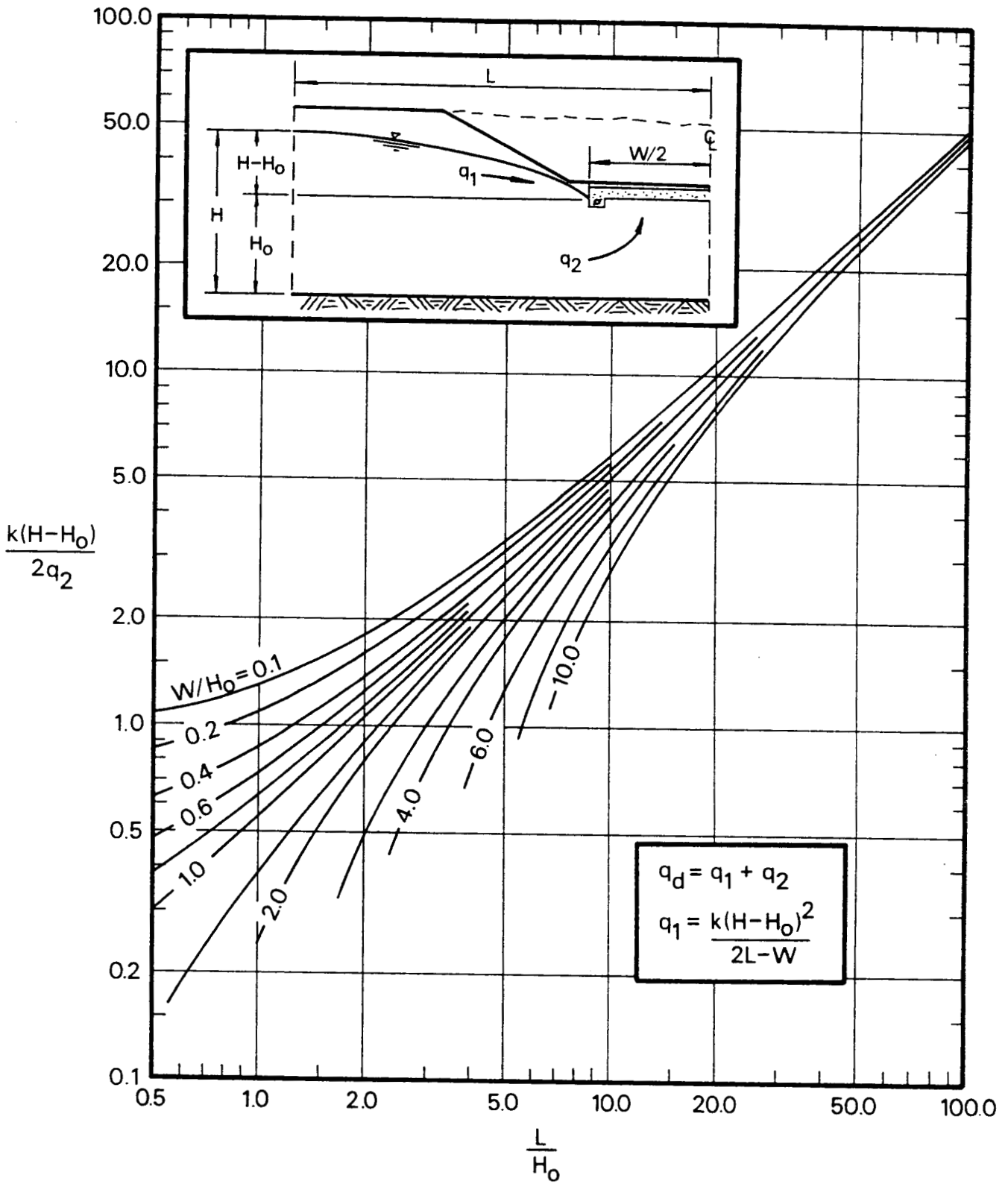

Figure 24. Chart for Determining Flow Rate in Horizontal Drainage Blanket

For the case of artesian flow, the average inflow rate can be estimated by the use of Darcy's Law, in the form:

$$q_a = K \frac{\Delta H}{H_o} \quad (D3)$$

where:

$q_a$  is the design inflow rate from artesian flow (cubic feet/day/square foot of drainage layer)  
 $\Delta H$  is the excess artesian head (feet), and  
 $H_o$  is the thickness of subgrade soil between the artesian aquifer and the drainage layer, as shown in Figure 23.

#### D.4.1 Application of Rational Analytical Methods - Examples

Example 1. Gravity Flow of Ground Water Into a Pavement Drainage Layer  
Consider the flow situation shown in Figure 25. The native soil is a silty sand with a measured coefficient of permeability,

$$K = 0.34 \text{ pfd.}$$

The average drawdown, determined from Figure 25, is:

$$(H-H_o) = (25.0 - 20.0) = 5.0'$$

Thus, the influence distance can be determined from Equation (D1) as

$$L_1 = 3.8(5) = 19.0.$$

Entering Figure 24 with

$$(L_1 + 0.5W)/H_o = (19.0 + 22)/20 = 2.05, \text{ and}$$

$$W/H_o = 44/20 = 2.2,$$

it is found that

$$K(H-H_o)/2q_2 = 0.74.$$

Therefore,

$$q_2 = 0.34 (5)/2(0.74) = 1.15 \text{ cfd/ft.}$$

Finally, the average inflow rate from the gravity flow of ground water can be calculated from Equation (D2) as

$$q_g = q_2/0.5W = 1.15/22 = 0.052 \text{ cfd/sf.}$$

In the actual design of a drainage system, such as that shown in Figure 25, some gravity seepage in addition to  $q_g$  would have to be considered. This flow

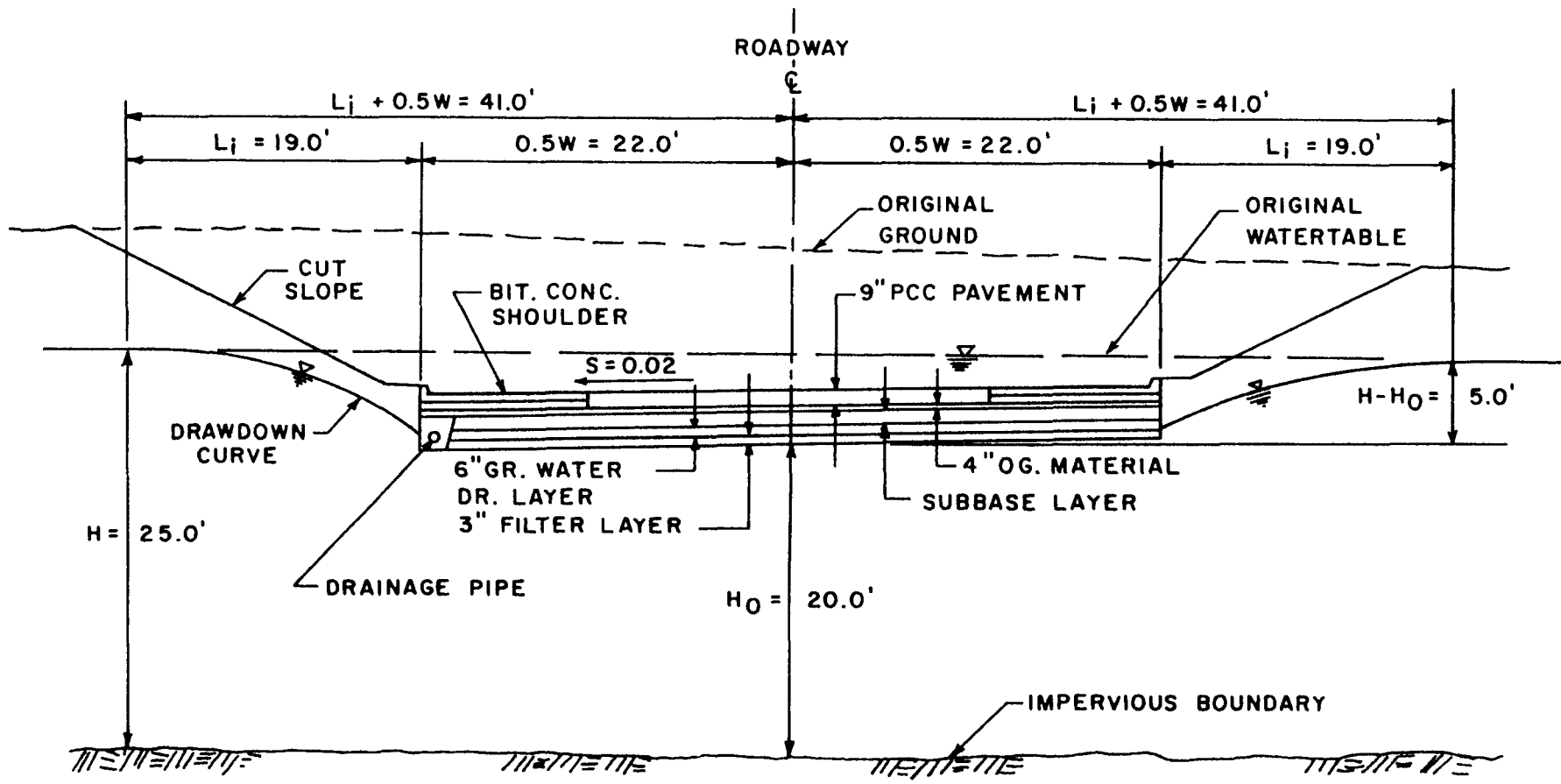

FIGURE #25. RIGID PAVEMENT SECTION IN-CUT.

is designated as  $q_1$  in Figure 24, and its magnitude would be

$$q_1 = K(H - H_0)^2 / 2L_i = 0.34(5)^2 / 2(19.0) = \underline{0.224} \text{ cfd/ft.}$$

The  $q_1$  flow from the left side would only be considered in the design of the collector drain. However, in this case, the  $q_1$  flow from the right side would have to be carried over to the left side to the collector drain and, thus, would have to be considered in the design of the drainage blanket.

Example 2. Artesian Flow of Goundwater Into a Pavement Drainage Layer.

Consider the flow situation shown in Figure 23. The subgrade soil above the artesian aquifer is a clayey silt with a coefficient of permeability:

$$K = 0.07 \text{ fpd.}$$

A piezometer installed during the course of the subsurface exploration program at this site showed that the piezometric head of the water in the artesian layer was about 8 feet above the bottom of the proposed pavement drainage layer, as shown in Figure 23. Using Equation (D3), with  $\Delta H = 8.0'$ ,  $H_0 = 15.0'$ , and  $K = 0.07$  fpd, gives:

$$q_a = \frac{0.07(8.0)}{15.0} = \underline{0.037} \text{ cfd/sft.}$$

It should be noted at this point that the quantity of groundwater that flows into pavement drainage layers is often relatively small. However, it should not be automatically concluded that inflow from groundwater sources can be neglected. The designer should estimate the inflow from all sources, since the cumulative effect of small inflows from several sources may be quite significant.

D.5 INTERCEPTOR DRAINS DESIGN PRINCIPLES

Considering the case of the unconfined flow of groundwater over a sloping impervious boundary toward an interceptor drain, as illustrated in Figure 26, the solution for this situation will take a form:

$$x = \frac{H \ln \frac{H-H_0}{H-y} - (y - H_0)}{S}, \tag{D4}$$

where:

- x and y are the coordinates of a point on the drawdown curve,
- H is the height of the original ground water table above an impervious boundary of slope S, and
- H<sub>0</sub> is the height of the drain above the impervious boundary.

An examination of Figure 26 and Equation D4 shows that the drawdown curve becomes asymptotic to the original free water surface (phreatic line) at infinity. Dealing with this boundary condition in practical problems is awkward; and, consequently, most solutions to gravity flow problems of this type have assumed that there is a finite distance, L<sub>1</sub>, from the drain at which the drawdown can be considered to be insignificant, and at which, for practical purposes, y=H, as shown in Figure 27. As already noted, the distance L<sub>1</sub>, to the point of insignificant drawdown is generally referred to as the "radius of influence."

Thus modifying the Equation D4 as indicated in Figure 27 it takes a form:

$$S_x = H' \ln \frac{H'-H_0}{H'-y} - (y - H_0), \tag{D5}$$

where:

H' is a point on a fictitious extension of the drawdown curve.

Substituting in Equation D5 for the condition that y = H when x = L<sub>1</sub> leads to the relationship:

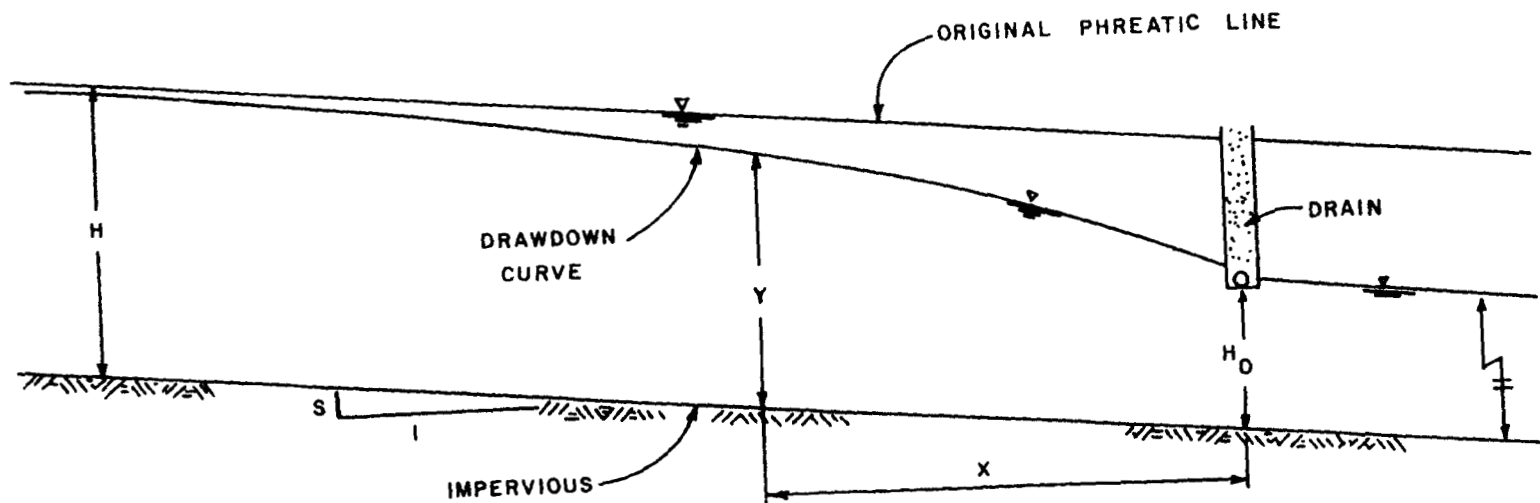

FIGURE #26. FLOW TOWARD A SINGLE INTERCEPTOR DRAIN

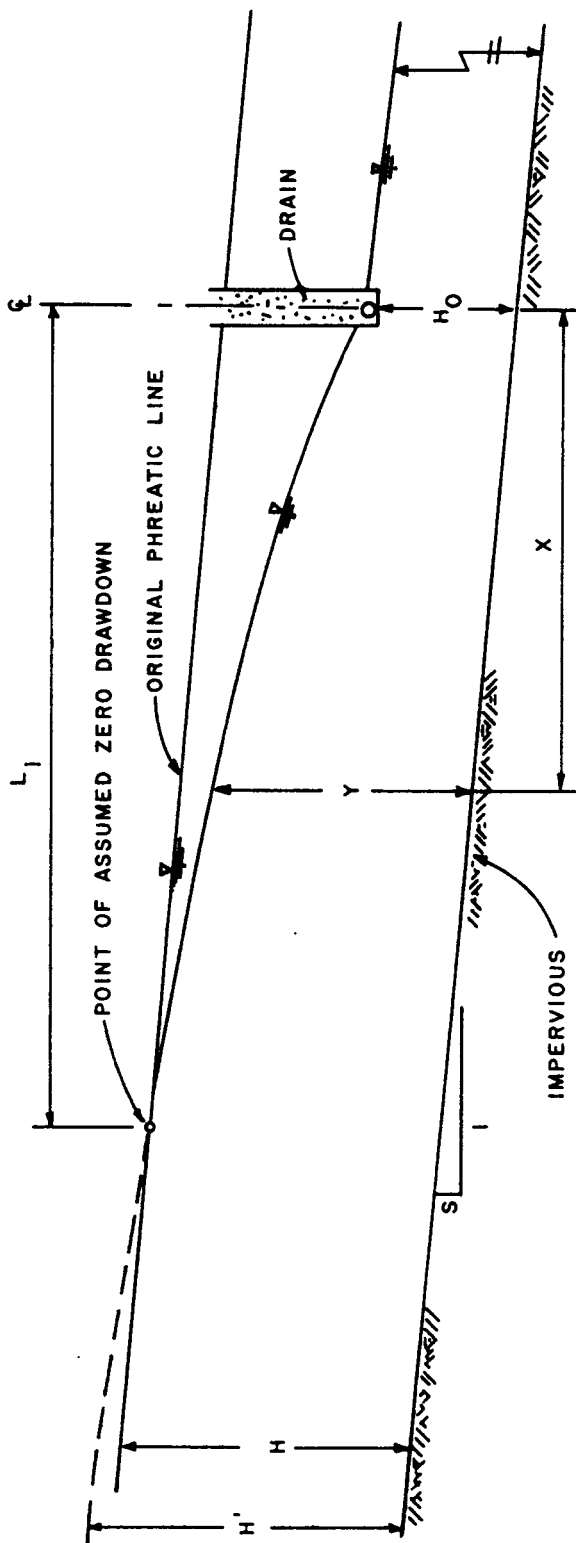

FIGURE #27. FLOW TOWARD A SINGLE INTERCEPTOR DRAIN WHEN THE DRAWDOWN CAN BE CONSIDERED TO BE INSIGNIFICANT AT A FINITE DISTANCE,  $L_i$  FROM THE DRAIN

$$SL_i = H' \ln \frac{H' - H_0}{H' - H} - (H - H_0), \quad (D6)$$

from which the value of  $H'$  can be determined for known values of  $S$ ,  $L_i$ ,  $H$  and  $H_0$ .

The quantity of flow into the drain,  $q_d$ , could be determined from the relationship:

$$q_d = q_0 \frac{(H' - H_0)}{H}, \quad (D7)$$

where:

$q_0$  is the magnitude of the approach flow, given by

$$q_0 = KHS, \quad (D8)$$

where:

$K$  is the coefficient of permeability of the porous medium.

A complete solution to the problem can thus be obtained from Equations D5 thru D8. For convenience, Equations D6 and D7 have been combined in dimensionless form and solved by computer to prepare Figure 28 from which  $q_d/KHS$  and  $H'/H$  can be determined in terms of known values of  $SL_i/H$  and  $H_0/H$ .

The same computations provided the data by which, through a change of variables, Figure 29 was prepared. Figure 29 permits the determination of the location of the drawdown curve, by giving values of  $Sx/y$  for known values of  $H_0/y$  and  $(H' - H_0)/y$ . In practice, a series of values of  $y$ , between  $H_0$  and  $H$ , are assumed, and Figure 29 is used to assist in the determination of the corresponding values of  $x$ .

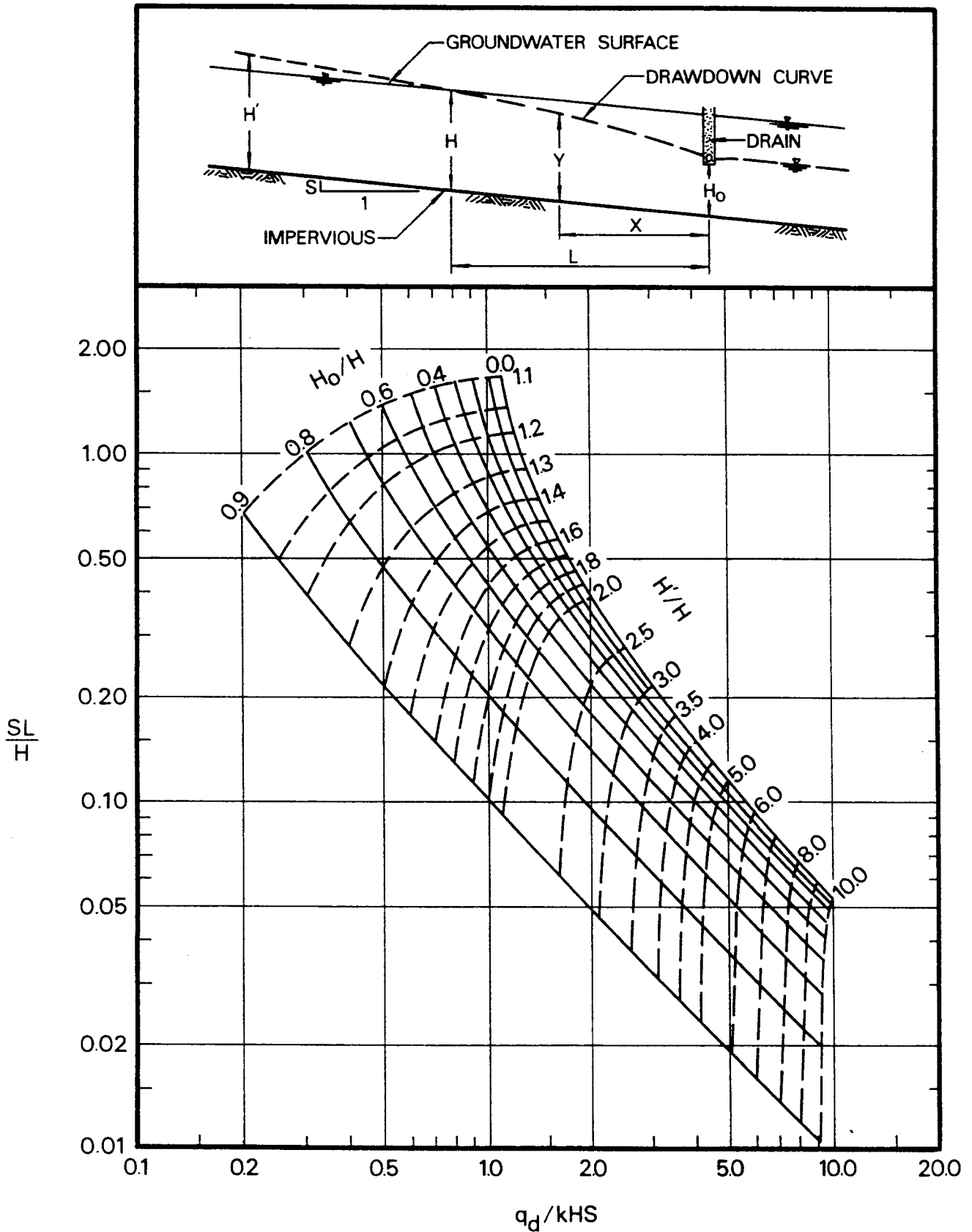

Figure 28. Chart for Determining Flow Rate in Interceptor Drains

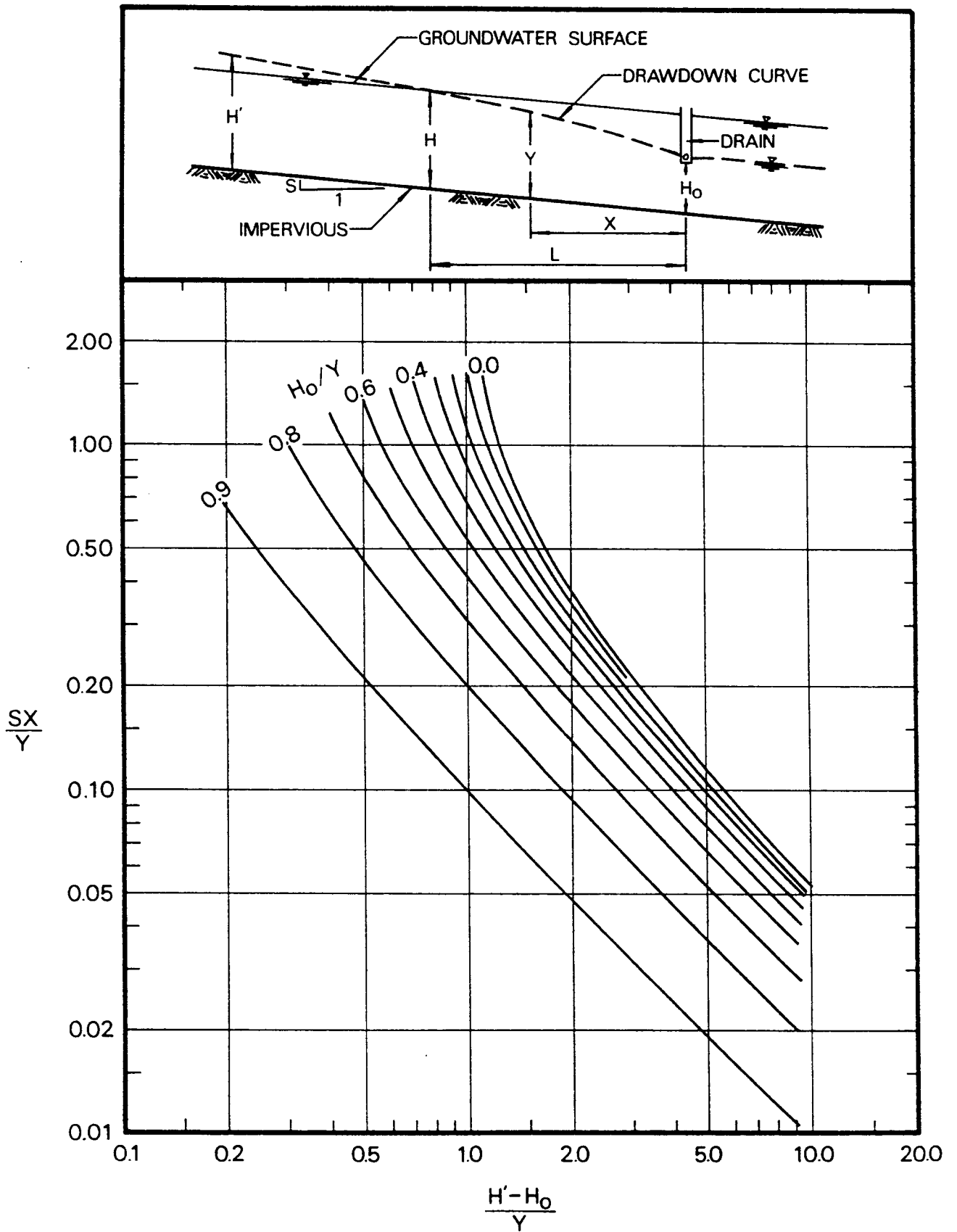

Figure 29. Chart for Determining Drawdown Curves for Interceptor Drains

In order to use Figures 28 and 29 for any highway drainage problem, it is necessary to have an estimate of the distance,  $L_1$ , beyond which the drawdown can be considered to be insignificant. As noted previously, this distance can be approximated for practical purposes by means of Equation D1.

Using the principles just outlined and considering each drain separately a subsurface drainage system of multiple interceptor drains can be designed. The same principles should be applied for solution of a system of symmetrical drawdown drains. The details of such solutions can be found in the report, FHWA-TS-00-224(2).

Although the method of analysis illustrated above yields a complete solution to the problem of a single interceptor drain, it should be recognized that the selection of the proper location of the drain involves considerable judgment and may even involve a trial and error process, particularly if the drain is being used to lower the watertable and reduce porewater pressures to achieve a certain measure of slope stability.

#### D.5.1 Analysis of an Interceptor Drain - Examples

Consider the proposed construction shown in Figure 22 and, for this problem, (a) compute the reduced flow rate,  $q_d/K$ , into the drain and (b) plot the location of the drawdown curve (free water surface). The detailed dimensions of the problem are given in Figure 30. In order to keep the left branch of the free water surface from breaking out through the cut slope and to lower the right branch of the free water surface well below the pavement structural system, the underdrain was set below the ditch line at a depth of 5 feet. It is proposed to pave the ditch over the drain to avoid infiltration and clogging.

Referring to Equation D1, and estimate of the value of the influence distance,  $L_1$ , is given as:

$$L_1 = 3.8(H - H_0) = 3.8 (14) = 53.2', \text{ Say } 53'.$$

From Figure 28, with

$$SL_1/H = 0.15(53)/20 = 0.398 \text{ and}$$

$$H_0/H = 6/20 = 0.3$$

it is found that  $q_d/KHS = 1.57$  and  $H'/H = 1.84$  (therefore  $H' = 1.84(20) = 36.8'$ .)

The above calculations form the basis for computing the reduced flow rate as

$$q_d/K = 1.57HS = 1.57(20)(0.15) = 4.71'.$$

Knowing the reduced flow rate, it is a simple matter to compute the actual flow rate,  $q_d$ , in the drain for any assumed or measured value of the coefficient of permeability,  $K$ .

From Figure 30, with  $H' = 36.8'$ , and the following assumed values of the  $y$  coordinates, the  $x$  coordinates of the drawdown curve can be determined as follows:

<u>y</u>	<u><math>H_0/y</math></u>	<u><math>(H'-H_0)/y</math></u>	<u><math>Sx/y</math></u>	<u>x</u>
7.4	0.811	4.16	0.041	2.0
8.8	0.682	3.48	0.080	4.7
10.2	0.588	3.02	0.117	8.0
11.6	0.517	2.66	0.149	11.5
13.0	0.462	2.37	0.190	16.5
14.4	0.417	2.14	0.226	21.7
15.8	0.380	1.95	0.265	27.9
17.2	0.349	1.79	0.310	35.5
18.6	0.323	1.66	0.350	43.4

This drawdown curve is plotted dashed in Figure 30.

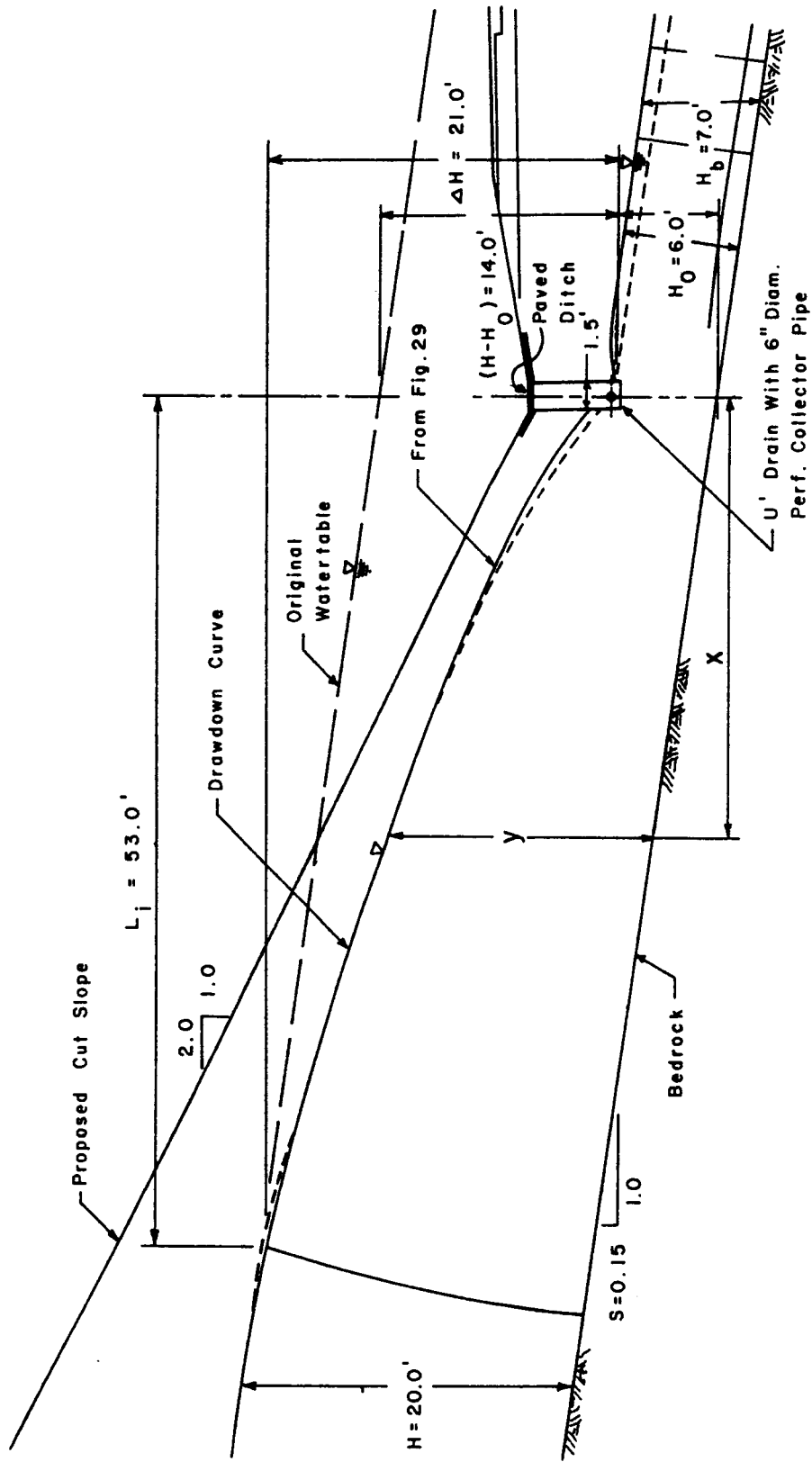

FIGURE #30. INTERCEPTOR DRAINS ANALYSIS

D. 6 MISCELLANEOUS GROUNDWATER DRAINAGE

Frequently, during the course of highway construction and maintenance operations, local seepage conditions are encountered which require subsurface drainage to remove the excess moisture or relieve porewater pressures. These conditions may require small drainage blankets with pipe outlets, longitudinal or transverse drains, or some combination of these drainage systems<sup>(11)</sup>. Although subdrainage of this type is highly individualized, its importance should not be minimized and its design should be approached with the same care as the design of more elaborate subdrainage systems.

E. CONSTRUCTION AND MAINTENANCE

E. 1 GENERAL

Although New Jersey has completed only a limited number of internally drainable roads this experience has demonstrated that such systems can be easily constructed under both portland cement concrete and bituminous concrete pavements. Importantly, this experience has also shown the possible pitfalls that can occur when less than concerned attitude exists on the part of the road builders. Attempting to build such systems with inadequate, unsuitable and dilapidated equipment is bound to be fraught with difficulties. Additionally, constructing only part of the underdrainage system and leaving it, say, over the winter to be completed next spring is totally unacceptable. Even neglecting it during the construction season is extremely ill-advised and will make it prone to considerable damage and probably even early failure at a later date due to possible contamination and degradation. Proper design and strict enforcement of the requirements of the plans and specifications is absolutely essential.

Since, however, such requirements of course also apply to the construction of any elements of a highway their enforcement should not cause increased costs when a reasonably conscientious contractor is involved.

Thus, the constructability of BSOG and NSOG drainage layers with proper equipment and in accordance with the procedures seems to cause few, if any, problems. However, if other than the specified equipment and procedures are used, placement of these materials can be somewhat problematic. The performance of such layers under rigid or flexible pavements, when proper confinement is provided, indeed seems to be adequate. When asphalt stabilized base is placed over a drainage layer, the BSOG material provides an adequate construction platform, while a NSOG layer, under adverse circumstances, might be somewhat unstable. The problems encountered with the NSOG layer seem to occur when adverse construction conditions require an unusual amount of maneuvering by the trucks delivering the mix to the paver. On one less than ideal project (Route 46, Sec. 17B) the end result of such maneuvering was ruts as deep as 0.5 to 1.0 inches in the OG layer, as Figure 31 indicates. In the limited applications of OG materials on the Rt. I-195 experiment and the Rt. 46, Section 17B application such rutting of the NSOG layer by trucks delivering the bituminous stabilized base course mix to the paver appears to be unavoidable. However, on Rt. 46, as shown in Figure 32, the rutting of the NSOG layer caused by trucks spinning the wheels was probably unnecessary. From this it must be apparent that if "normal" rutting is not tolerable in such cases, use of the BSOG drainage layer is recommended. However, if the NSOG material is used, with careful construction practices, a laborer with a rake and the occasional use of a small compactor-roller can keep the surface in an adequate shape.

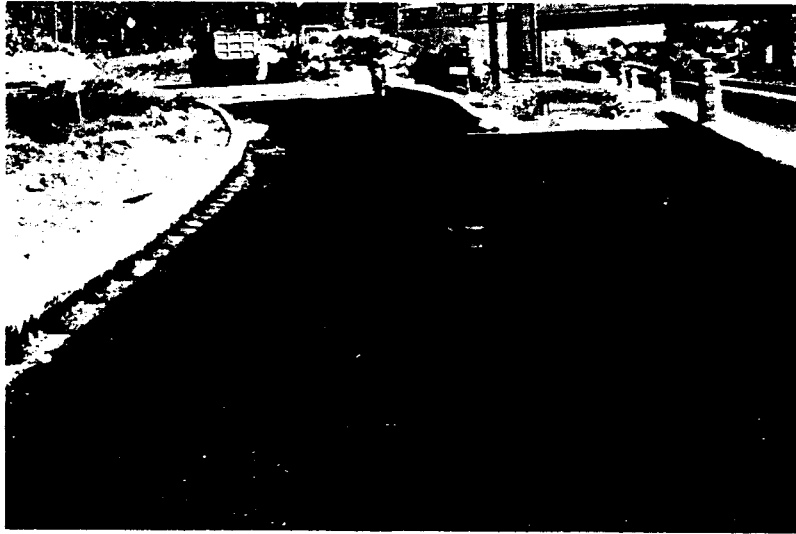

FIGURE 31. Route 46, Placing BSBC Material on Top of NSOG Layer. "Normal" Truck Rutting Delivering BSBC Mix



FIGURE 32. Route 46, Placing BSBC Layer. Truck Rutting Caused by Unnecessary Wheels Spinning

The best means for including the special underdrainage in roadways is first to construct all subbase. If required, the top of the subbase is then stabilized or the filter cloth barrier is placed to provide a construction platform and to prevent the intrusion of fines into the overlying drainage layer. This is followed by the construction of the collection system. The drainage layer is then placed.

Irrespective of the proper design and construction of a subsurface drainage system some maintenance will be required to insure the system's continuous operation. To the extent possible, all features of the system should be designed for minimum maintenance. Nevertheless, a program of continuing regular inspections, preventive-type maintenance and repair-type maintenance must be anticipated.

## E.2 CONSTRUCTION OF THE COLLECTION SYSTEMS

In constructing the longitudinal and transverse collectors, the procedure should be to excavate through the subbase to a prescribed depth. Then, as shown in Figure 33 the trench should be lined with filter cloth by unrolling it by hand for about 30 feet ahead of the backfilling operation. While two laborers hold the edges, a third man should walk the filter fabric conforming it to the dimensions of the trench. After that, a drainage pipe should be placed on 3 inches of #8 stone bedding and backfilled with #8 stone. Beginning 12 inches above the top of the pipe, the backfill in the trenches must be compacted in 6 inch lifts by 3 to 4 passes of a vibratory plate compactor.

The construction of the outlet ditches is similar, except solid wall (non-perforated) pipes and regular subgrade soils for bedding and the backfill



FIGURE 33. Route 195, Drainage Ditch with Filter Cloth Lining, Drain Pipe and the Backfill being Compacted



FIGURE 34. Route 195, Example of a Daylighted Outlet Pipe

must be used. The outlet pipes should either be daylighted, as shown on Figure 34, or terminated in the surface drainage inlet structures.

The procedure for the trench construction acceptable for a small job requires the use of a Grad-All for trench excavation, a front loader for placement of the backfill and regular trucking for material transportation. Although 1000 feet per day of such trench construction might be achievable, considerably better progress in the order of 2000 to 3000 feet per day should be possible if more appropriate equipment and construction scheduling were used. For example, a significant increase in the efficiency of the trenching operation could be realized if use would be made of a trenching machine, such as a Ditch Witch, and modified trucks to "funnel" stone into the ditch. All this coupled with adequately scheduled removal of the excavated material and supply of pipe and backfill would considerably improve construction progress.

### E.3 CONSTRUCTION OF NSOG AND BSOG DRAINAGE LAYERS

Placement of the open-graded layers (both NSOG and BSOG) can be best accomplished with an asphalt paver (see Figures 35 and 36). Whether or not a stone spreader for placing a non-stabilized open-graded layer is usable depends on the degree of precision the equipment is capable of; it must be at least equivalent to the precision of an asphalt paver with automatic grade control. For placing NSOG & BSOG materials the use of a tracked paver is recommended. Additional fine grading with a grader should be nil. Slightly moist (about 2% of moisture) NSOG material can be handled by an asphalt paver with no modification or damage to the equipment. The NSOG material should be compacted by a vibratory roller, while the BSOG layer can be compacted with standard static rollers (three wheel breakdown roller followed by tandem finishing roller) as



FIGURE 35. Route 195, Placing of the NSOG Layer by an Asphalt Paver



FIGURE 36. Route 195, Placing of the BSOG Layer by an Asphalt Paver

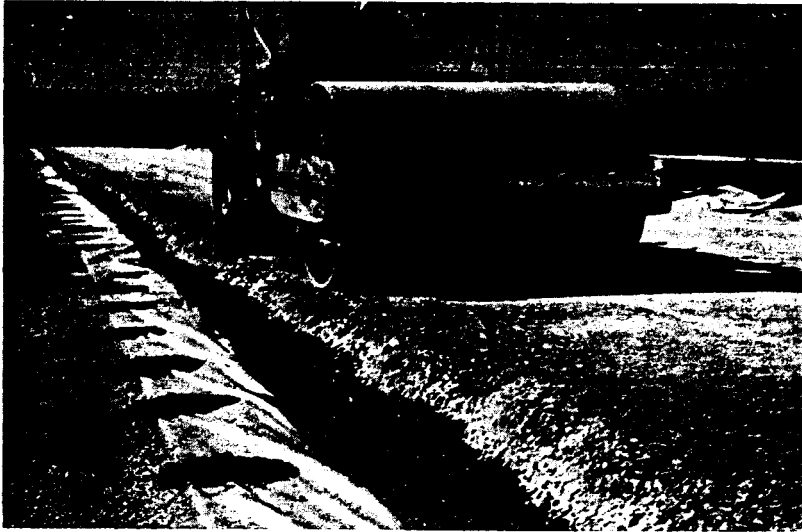

FIGURE 37. Route 195, the NSOG Layer is Being Compacted by a Vibratory Roller

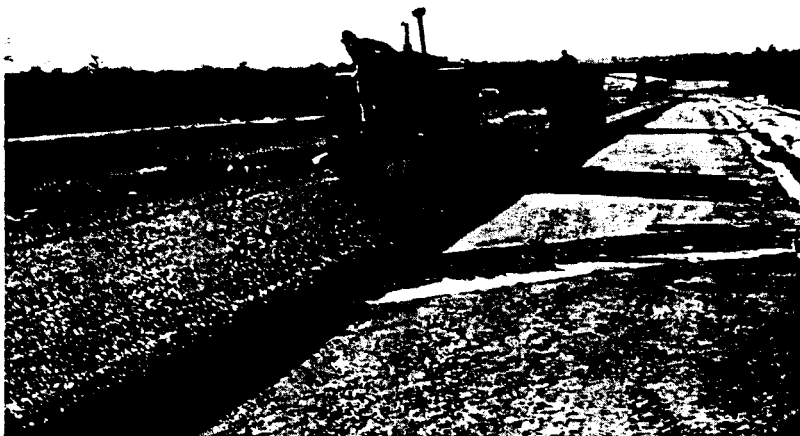

FIGURE 38. Route 195, the BSOG Layer Compaction by a Three-wheel and a Tandem Roller

shown in Figures 37 and 38. The vibratory asphalt rollers could possibly be used on the BSOG material, but the mix temperature would have to be appropriately lower to prevent edge shoving.

Considering the fact that the BSOG mix seems to be somewhat unstable when hot -- excessive spreading has been observed at the edges during compaction --it is advisable for compaction to commence at a temperature of about 210°F. For permeability reasons the mix is rather open with few fines, if any, in it. Thus, the asphalt tends to act more as a lubricant aiding compaction with this mix more than with conventional dense-graded bituminous mixtures. The lower compaction temperature permits the asphalt viscosity to increase and its bonding ability to take over to achieve a more stable mix for compaction.

The test strip approach for compaction control of the open-graded layers seems to work well. Since this approach relies only on relative density measurements, a nuclear gauge operated in whatever mode, be it in the backscatter position with or without surface preparation or in the direct transmission mode, should be adequate. A nuclear gauge, as shown in Figure 39 is used to monitor the increasing densities at the same three locations within a control strip between successive roller passes. As the compacted material approaches the maximum density achievable in the field, the average difference between any two consecutive passes approaches zero. Under the direction of the engineer, rolling must continue until this average density difference is less than or equal to 0.5 pcf. At this point maximum density is inferred since the observed density failed to increase with additional passes. Based on statistical data from the experimental installations, it is expected that most BSOG strips will require approximately 6 passes and less than 5% of the control strip



FIGURE 39. Route 195, Monitoring of the Control Strip  
Compaction by a Nuclear Gauge

applications should require more than 10 passes. For NSOG control strips the average number of required passes should be approximately five.

As already stated, construction of pavement courses above the open-graded layers should not be difficult if proper equipment is used. After it has cooled, the BSOG material hardenes into a very firm layer which represents an adequate construction platform for both the portland cement and bituminous concrete surfacings. It should be mentioned that the anchor pins for the concrete pavement forms can be driven through the bituminous stabilized open graded and lime-fly ash stabilized layers without difficulty. Placement of the PCC pavement on the BSOG layer is shown in Figure 40, while Figure 41 shows the paving of the bituminous stabilized base on a BSOG layer.

After the construction of the NSOG layer, no problems should be expected in either grading or setting forms for portland cement concrete pavement. The form work can be placed on the non-stabilized open-graded material without difficulty and the hold down pins can be driven easily through the non-stabilized open-graded layer into the stabilized material using a pneumatic hammer. As shown in Figure 42, a fine grading machine riding on the forms can be used to achieve finished grade, followed by a small roller to compact and smooth out the surface.

Conventional paving procedures illustrated in Figure 43 is all that is necessary for placement of concrete on the NSOG layer.

No shrinkage cracks in the concrete road slabs and little infiltration of the concrete into the either open-graded layer has been observed. The later case should dispel fears of excessive friction between underlying open-graded material and the pavement slabs.



FIGURE 40. Route 676, Pouring of Portland Cement Concrete on the Top of the Bituminous Stabilized Open-Graded Layer



FIGURE 41. Route 195, Paving of the Bituminous-Stabilized Base on the Top of the Bituminous-Stabilized Open-Graded Layer

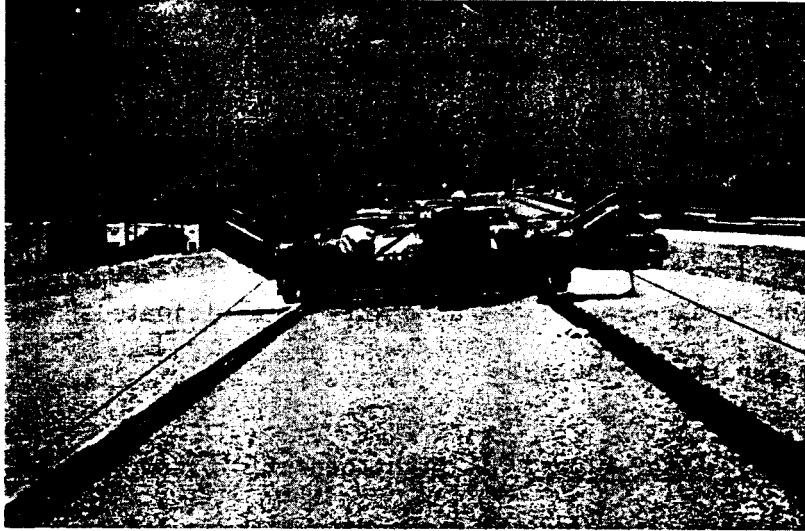

FIGURE 42. Route 676, Fine Grading of the Non-Stabilized Open-Graded Material

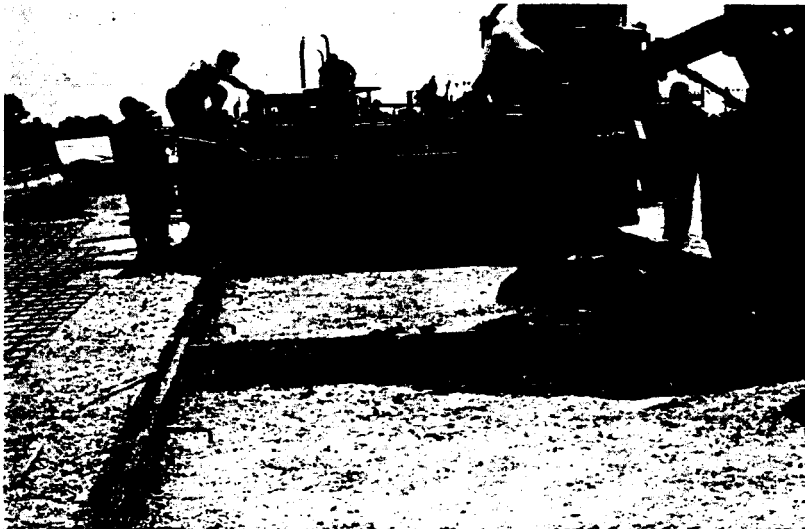

FIGURE 43. Route 676, Portland Cement Concrete Paving Operation on the Top of the Non-Stabilized Open-Graded Layer

#### E.4 MAINTENANCE OF SUBSURFACE DRAINAGE SYSTEMS

Irrespective of the proper design and construction of a subsurface drainage system, some maintenance will be required to insure that the system continues to operate in a satisfactory fashion. In other words, no action or lack of action should be allowed to reduce the efficiency of the system. To the extent possible, all features of the system should be designed for minimum future maintenance. However, every operating condition for the system cannot always be anticipated. Thus, a program of continuing regular inspections, preventive-type maintenance, and repair-type maintenance must be anticipated. These maintenance procedures include the following:

Cleaning of Collector Pipes: It might be anticipated that sediment could be deposited in collector pipes due to inadequate pipe gradients, uneven settlement of the system and/or a heavy sediment load. In anticipation of such a possibility, clean-out boxes or risers at various locations within the pipe network could be designed into the system. In addition, the pipe network should be designed in such a way that right angle turns are eliminated. If a routine inspection of the system suggests the possibility of reduced efficiency, the collector pipe network should be flushed using large quantities of clean water. If clean-out facilities such as those described above were not included, then cleaning would require back flushing and, perhaps, "snaking" through the outlet pipes.

Maintenance of Outlets: The outlet system must be maintained in a free-flow condition throughout the life of the facility. With respect to pipe outlets, the principal concerns would be the blockages due to weed growth, siltation of the adjacent ditch, debris from the roadway or slope, and activity of animals or

man. In addition, flap valves installed on outlets to minimize blockages due to animal activity or backflow could become stuck because of some of the aforementioned causes as well as damage to or corrosion of the valve hinge. Only through periodic inspection can these circumstances be identified and subsequently rectified. Such inspections should be made prior to seasonal periods of heavy rainfall as well as following particularly heavy rainfall events and/or at least once every three months.

In addition to the outlets themselves, the outlet markers should be maintained in good condition. Damaged markers should be repaired or replaced immediately. Any marker destroyed or damaged during other construction or maintenance activities should be immediately reported for replacement or repair.

Miscellaneous Maintenance and Other Considerations: Careful periodic inspections are the key to adequate maintenance of the subsurface drainage system. However, other related maintenance activities associated with the pavement, pavement shoulder, surface drainage systems, ice/snow control and removal, right-of-way mowing, etc. can all have an impact on the operation and maintenance of the subsurface drainage system. Although the maintenance of the subsurface drainage system might not take precedence over one of the aforementioned activities, it must not be relegated to an insignificant status. For example, although mowing is an essential maintenance activity, it has a potentially detrimental effect on the outlet system. That is, the mowing machines could damage the outlets through impact with the outlets during the mowing operations. If the likelihood of such an occurrence is high, use of erosion control aprons or chemical weed control could be utilized in lieu of mowing.

Maintenance that insures the efficient collection and removal of surface water will also generally improve the operation of the subsurface drainage

system. Timely repairs of damage to surface drainage structures, pipes, ditches, etc., will contribute to the proper operation of the subsurface drainage system. Likewise, timely and cautious repairs of damaged pavement and pavement shoulder sections will be beneficial to the underdrain system.

Those responsible for the care of the subsurface drainage systems should maintain detailed as-built plans of the systems to facilitate subsequent repairs and replacements. In addition, a separate record of the location of drainage facilities, particularly outlets, should be maintained so that these facilities can be easily located by maintenance personnel. Inspection records should be kept along with records of each maintenance activity required by the system. If these records are kept in a continuous fashion they may suggest the need for some more substantial efforts to prevent the recurrence of some continuing maintenance problem. The information concerning the modification of conditions adjacent to the subsurface drainage system must also be diligently gathered and assessed. Any modification or change that would adversely affect the operation of the subsurface drainage system (e.g. changes in the surface drainage facilities etc.) should be corrected promptly to mitigate the potentially detrimental effects.

## F. SUBSURFACE DRAINAGE AND PAVEMENT REHABILITATION

### F.1 GENERAL

Like most other highway agencies, the focus of the work program of the NJDOT is increasingly directed at preserving and maintaining the highway network, rather than making additions to the system. For example, about 90% of the projects currently initiated by the Department's Design unit concern resurfacing or reconstruction, while only about 10% involve new construction.

On at least certain of these candidate rehabilitation projects, the existing distress was caused by water-induced damage. Therefore, to provide an effective solution to the problem on these projects, the proposed rehabilitation technique must address the water-in-the-pavement issue. This report section outlines a design and construction methodology which would permit the internal drainage concept developed in this research to be applied to the rehabilitation projects which now constitute the major focus of the Department's work.

If it needs to be said, the open-graded drainage solution subsequently described herein is not a panacea and should be used selectively on only those projects where warranted. Obviously, if the pavement damage on a proposed rehabilitation project is caused by factors other than subsurface water, only conventional restoration techniques should be performed since the project's drainage ostensibly is functioning by some natural means (such as permeable enough subgrades.)

In a highly urbanized, heavily trafficked state such as New Jersey, implementation of any type of rehabilitation solution can pose problems. These normal construction problems can be accentuated by applying the particular solution proposed here for alleviating water-related damage. That is, as noted earlier in this report, traffic definitely should not be rerouted over an open graded drainage layer due to possible problems of stability (e.g., shoving and rutting) and/or contamination of the drainage layer. Traffic control on a project incorporating an open-graded drainage layer thus would require a particularly well-thought-out plan. Secondly, since an internally drainable pavement requires a substantially thicker section than a conventional resurfacing (i.e., 10 inches), in a highly urbanized area, this solution would have to be applied

as a reconstruction rather than an overlay due to problems in meeting the elevation of existing highway appurtenances (e.g., barrier curb, sidewalks).

While use of the solution proposed here thus requires special traffic control measures and a higher initial cost, it seems to be the only viable approach. Consider the alternate: If a conventional rehabilitation technique (e.g., resurfacing) is applied to a pavement whose foundation has been undermined by inadequate subsurface drainage, this will only temporarily postpone the inevitable further disintegration of the pavement structure, resulting to a large degree in a useless expenditure of scarce maintenance funds. A discussion of the economic aspects involved in the use of the open graded drainage solution on rehabilitation projects is described in an informal Department report (19).

## F.2 DESIGN GUIDELINES FOR SUBSURFACE DRAINAGE ON PAVEMENT REHABILITATION PROJECTS

The recommended approach for pavement rehabilitation projects, where the drainage is inadequate proposes constructing an overlay consisting of four inches of BSOG material directly on the existing pavement surfacing and draining it into drainage trenches and outlets as detailed else where in this guide. Due to possible stability problems during the construction, NSOG material is not suggested for use in such a rehabilitation effort.

As noted earlier in this report, to insure adequate confinement and stability, the BSOG drainage layer must be overlaid with a minimum of three inches of bituminous stabilized base and three inches of bituminous surfacing.

While some refinements/modifications of the above suggested design methodology may be possible as we gain further experience, at the present time, an

attempt to apply the internal drainage solution to only parts of a road (e.g., in the shoulder areas only) appears ill-advised. Such a partial solution might not only be unsuccessful, but also conceivably could cause an increased possibility for distress (e.g., through the creation of a "bathtub" effect).

In transition areas between the existing and rehabilitated sections of roadway, protection for the newly installed subsurface drainage facilities should be provided through use of a filtration media (e.g., a filter fabric) at the beginning and end of the project. To ensure proper functioning of the system, adequate drainage outlets must be installed within the project limits.

As in the construction of new pavements, the recommended subsurface drains are designed to handle water which infiltrates the pavement area only. It is assumed that the surface drainage is functioning and that the runoff from the surrounding areas will be drained by it.

Where groundwater is an expected problem an investigation of the water bearing strata should be made, including depth and permeability of the strata and amount of water carried by it. This investigation will allow the designer to increase the pipe size to insure adequate capacities for all sources of water.

### F3. METHODS OF CONSTRUCTION

The general internal drainage construction procedures suggested for new construction should be followed for rehabilitation projects. Additionally, to prevent damage to the subsurface drainage system during construction, the following sequence of construction should be followed:

1. Prepare the existing pavement surface so that it is structurally sound and reasonably clean. Badly unstable slabs should be repaired or otherwise stabilized prior to installation of the open graded layer.

2. Construct drainage ditches and pipe network. No ditches shall be left open (without backfill) for more than 24 hours.

3. Construct 4 inch BSOG drainage base course at the locations shown on the plans. The underdrain network and the drainage base course shall be protected at all times from any contamination that might diminish their ability to transport water until pavement is constructed over it. Any contaminated or damaged drainage base course or drainage elements caused by the contractor's negligence shall be replaced by the contractor at no cost to the state. Only traffic necessary for construction of these pavement sections will be permitted on the drainage base course. All other traffic must be detoured.

4. Immediately following the construction of the drainage base course the contractor shall "seal" its outer edges with the bituminous stabilized base course.

Any area of the drainage course which becomes impaired by infiltration and clogging shall be reconstructed at the direction of the Engineer. During the construction of the drainage course and until the Contractor has entirely covered the course with pavement or other "sealing" layers, it shall be the Contractor's responsibility to maintain drainage of the job site such that fine material is not allowed to wash into and clog any part of the drainage system. Specific details of the procedure described above are as follows:

Trench Excavation, Pipe Laying and Backfill: Excavation, pipe laying, and backfilling of trenches shall be performed as directed by this guide.

It shall be the Contractor's responsibility to provide drainage of the roadway such that the open-graded backfill of trenches does not become clogged with erosion material. Where the outlet pipes for these underdrains enter manhole or inlet basin structures, the Contractor shall take necessary means to prevent all soil from entering the pipes through the basin.

Bituminous-Stabilized Drainage Layer: A drainage base course shall be placed in the required areas, and compacted to the prescribed thicknesses, and grade. The methods of construction shall be as specified in this guide.

Construction Staging: To avoid extensive obstruction of traffic flow and impairment of traffic safety, the construction sequence should be such as to keep at least one lane easily accessible at all times. To achieve this, the construction should begin with the excavation of longitudinal ditches at the edges of the existing pavement, the placement of pipe network and the pipe backfill.

Since the normal capacity of a paving operation is about 1500 tons per day, approximately a lane-mile of a 4 inch thick, 12 ft. wide layer can be placed in a day. This means that one lane-mile or two half lane-miles of 4 inch drainage layer can be placed in one lift in a day. However, only light traffic should be allowed on the completed drainage base course and only that which is necessary for the construction of the pavement to be placed above this base course. In fact, the drainage base course should not serve as a haul road for construction operations elsewhere on the project, on the other hand, an excessively thick layer might cause dangerous driving conditions. Thusly, to protect the driver of a vehicle, the functioning of the drainage layer and to facilitate construction either full width or lane at a time placement of the bituminous stabilized

drainage base will be permitted. If full width paving is not used, then the paving operation shall commence at the outside edge of the underdrain trench in the outside shoulder and progress across the width of the roadway.

Immediately following the construction of the open-graded base course, the Contractor shall "seal" the outer edges of the course and the shoulder with bituminous stabilized base course. In no case shall these edges be left unprotected and subject to infiltration. In the case of four or six lane roads, all traffic should be rerouted to one side of the highway and the pavement rehabilitation initiated on the opposite side. The construction then can proceed by placing first a days production of the four inch drainage layer and then the following day topping that layer with bituminous stabilized base. The required quantity of stabilized base in the shoulder areas would also be placed during the second day. This procedure would be repeated until the entire highway had been paved in one direction with both the drainage and stabilized base mixtures. At that time the MABC pavement layer could be placed. While other incidental work continues, traffic could then be rerouted to the overlaid side and rehabilitation work started on the opposite side in the same sequence.

In instances of two-lane roadways where a lane at the time must be worked on, while keeping an adjacent lane open, a somewhat adverse procedure will have to be adopted. With this approach, at any one time traffic will be rerouted to one side of the road using both the normal traffic lane and shoulder for the two directions of travel. Starting on one side of the pavement, after completion of enough of drainage system, that can be protected within 24 hours, days production of the four inch drainage layer and BSBC shoulder layer four inches thick should be constructed. The next day while keeping the opposite side open to

traffic the previous day's drainage and shoulder layers should be covered by three inches of BSBC. On the third day, while opening the overlaid side to traffic, on the opposite side the amount of drainage system that can be protected within 24 hours should be completed. On the fourth day, a day's production of the drainage layer and of the matching BSBC shoulder layer should be constructed. On the fifth day the last drainage and shoulder layer sections should be covered by three inches of BSBC. Subsequent days construction should commence as before until completion of said section rehabilitation, at which time the MABC pavement layer can be prudently constructed and other incidental work accomplished.

REFERENCES

1. Cedergreen, Harry R., Arman Jorge A. and O'Brien, Ken H., Development of Guidelines for the Design and Subsurface Drainage Systems for Highway Pavement Structural Sections, FHWA, February, 1983.
2. Moulton, Lyle K., PH.D.P.E., Highway Subdrainage Design, FHWA, August, 1980.
3. Kozlov, George S., Road Surface Drainage Design, Construction and Maintenance Guide for Pavements, June, 1981
4. Cedergreen, Harry R., O'Brien, K. H., and Arman, Jorge A., Guidelines for the Design of Subsurface Drainage Systems for Highway Structural Sections, June, 1972.
5. Ridgeway, Dallas H., Infiltration of Water Through the Pavement Surface, TRB 616, p. 98-100.
6. Kozlov, George S., Mottola, Victor E., Mehalchick, Gregory, Improved Drainage and Front Action Criteria for New Jersey Pavement Design, Volume I - Investigations for Subsurface Drainage Design, FHWA, N.J. Project 7740, October, 1982.
7. Casagrande, A., ASCE and W. L. Shannon Associates, M. ASCE, Base Course Drainage for Airport Pavements, Proceedings, Volume 77, June, 1951.
8. NJDOT, 1980 Supplement to the Standard Specifications for Road and Bridge Construction.
9. 1980 Annual Book of ASTM Standards, Part 19, Natural Building Stones, Soil and Rock.
10. 1980 Annual Book of ASTM Standards, Part 15, Road and Paving Materials; Bituminous and Polymeric Materials for Highway Construction, Water-Proofing and Roofing, and Pipe; Traveled Surface Characteristics.
11. Kozlov, George S., Mottola, Victor E., Mehalchick, Gregory, Improved Drainage and Frost Action Criteria for New Jersey Pavement Design, Volume II, Experimental Subsurface Drainage Applications, 1983.
12. Mottola, Victor E., Feasibility of Pavement Stabilization in New Jersey, September, 1982 (unpublished).
13. Barenberg, Ernest J. and Tayabji, Shriaz D., Evaluation of Typical Pavement Drainage Systems Using Open Graded Bituminous Aggregate Mixture Drainage Layers, May 1974.
14. Barenberg, Ernest J. and Brown, Douglas, Modeling of Effects of Moisture and Drainage on NJDOT Flexible Pavement Systems, April, 1981.

REFERENCES (Continued)

15. Barenberg, Ernest J., Effects of Moisture and Drainage on Behavior and Performance of NJDOT Rigid Pavement Systems, July 1981.
16. Drainage and Erosion-Control Structures for Airfields and Heliports, Department of the Army Technical Manual, TM 5-820-3, July, 1965.
17. Subsurface Drainage Facilities for Airfields, Department of the Army Technical Manual, TM-5-820-2, August 1965.
18. R. E. Chambers, T. J. McGrath, F. J. Heger, Plastic Pipe for Subsurface Drainage of Transportation Facilities, TRB report 225, October, 1980.
19. Kozlov, George S., Rehabilitation of Pavements Damaged by Inadequate Subsurface Road Drainage, March, 1979.

A P P E N D I X A

DRAINAGE LAYER

FLOW RATES, Q

AND

FLOW PATH LENGTHS, L

TABLE A1: DRAINAGE LAYER BASIC DATA

ROAD CONFIGURATION 1

		CROSS SLOPE (FT/FT)	LANE WIDTH (FT)		
LANE ONE		0.010	12.		
LANE TWO		0.0	0.		
LANE THREE		0.0	0.		

LONGITUDINAL SLOPE (FT/FT)	K PERMEAB. (FT/DAY)	Q FLOWRATE (CF/DAY)*	T TIME (HOURS)	H0 TOTAL HEAD (FT)	L TOTAL LENGTH (FT)
0.005	1000.	11.8	2.70	0.48	13.42
0.010	1000.	11.1	3.64	0.57	16.97
0.015	1000.	11.0	4.68	0.72	21.63
0.020	1000.	11.4	5.57	0.93	26.83
0.025	1000.	12.3	6.26	1.20	32.31
0.030	1000.	13.3	6.78	1.53	37.95
0.035	1000.	14.5	7.15	1.92	43.68
0.040	1000.	15.8	7.44	2.37	49.48
0.045	1000.	17.2	7.65	2.88	55.32
0.050	1000.	18.6	7.81	3.45	61.19
0.055	1000.	20.1	7.94	4.08	67.08
0.060	1000.	21.6	8.04	4.77	72.99

ROAD CONFIGURATION 2

		CROSS SLOPE (FT/FT)	LANE WIDTH (FT)		
LANE ONE		0.010	12.		
LANE TWO		0.040	12.		
LANE THREE		0.0	0.		

LONGITUDINAL SLOPE (FT/FT)	K PERMEAB. (FT/DAY)	Q FLOWRATE (CF/DAY)*	T TIME (HOURS)	H0 TOTAL HEAD (FT)	L TOTAL LENGTH (FT)
0.005	1000.	12.5	4.84	0.97	25.51
0.010	1000.	12.1	5.74	1.08	29.34
0.015	1000.	12.1	6.74	1.27	34.45
0.020	1000.	12.5	7.62	1.53	40.25
0.025	1000.	13.3	8.32	1.87	46.46
0.030	1000.	14.2	8.85	2.28	52.95
0.035	1000.	15.3	9.25	2.77	59.63
0.040	1000.	16.5	9.55	3.33	66.45
0.045	1000.	17.8	9.77	3.97	73.38
0.050	1000.	19.2	9.94	4.68	80.40
0.055	1000.	20.6	10.08	5.47	87.48
0.060	1000.	22.1	10.18	6.33	94.63

\* Q values provided are for one foot width of a drainage layer. The total Q for a specific length of roadway is obtained by multiplying the table value by the length between outlets in feet.

between outlets in feet.

specific length of roadway is obtained by multiplying the table value by the length

\* Q values provided are for one foot width of a drainage layer. The total Q for a

0.005	1000.	8.6	7.19	0.68	26.07
0.010	1000.	8.7	8.55	0.83	31.39
0.015	1000.	9.2	9.94	1.08	38.60
0.020	1000.	10.1	11.04	1.43	46.83
0.025	1000.	11.2	11.85	1.88	55.63
0.030	1000.	12.4	12.43	2.43	64.78
0.035	1000.	13.7	12.85	3.08	74.14
0.040	1000.	15.1	13.16	3.83	83.65
0.045	1000.	16.6	13.38	4.68	93.26
0.050	1000.	18.0	13.55	5.63	102.95
0.055	1000.	19.6	13.69	6.68	112.69
0.060	1000.	21.1	13.79	7.83	122.47

LONGITUDINAL SLOPE (FT/FT)	PERMEAB. (FT/DAY)	Q FLOWRATE (CF/DAY) *	T TIME (HOURS)	H0 TOTAL HEAD (FT)	L TOTAL LENGTH (FT)
THREE	0.0	0.0	0.		
TWO	0.015	12.	12.		
ONE	0.010	12.	12.		
LANE (FT/FT)		LANE WIDTH (FT)			
CROSS SLOPE		LANE WIDTH			

ROAD CONFIGURATION 4

LONGITUDINAL SLOPE (FT/FT)	PERMEAB. (FT/DAY)	Q FLOWRATE (CF/DAY) *	T TIME (HOURS)	H0 TOTAL HEAD (FT)	L TOTAL LENGTH (FT)
THREE	0.0	0.0	0.		
TWO	0.040	6.	6.		
ONE	0.010	12.	12.		
LANE (FT/FT)		LANE WIDTH (FT)			
CROSS SLOPE		LANE WIDTH			

ROAD CONFIGURATION 3

ROAD CONFIGURATION 5

LONGITUDINAL SLOPE (FT/FT)	PERMEAB. (FT/DAY)	R FLOWRATE (CF/DAY)*	T TIME (HOURS)	HO TOTAL HEAD (FT)	L TOTAL LENGTH (FT)
0.005	1000.	10.1	8.98	1.17	38.16
0.010	1000.	10.1	10.29	1.34	43.76
0.015	1000.	10.4	11.70	1.63	51.42
0.020	1000.	11.1	12.87	2.03	60.25
0.025	1000.	12.0	13.76	2.55	69.79
0.030	1000.	13.2	14.41	3.18	79.78
0.035	1000.	14.4	14.88	3.93	90.09
0.040	1000.	15.7	15.22	4.79	100.62
0.045	1000.	17.1	15.47	5.77	111.33
0.050	1000.	18.5	15.66	6.86	122.16
0.055	1000.	20.0	15.81	8.07	133.09
0.060	1000.	21.5	15.92	9.39	144.10

CROSS SLOPE (FT/FT) LANE  
 ONE 0.010  
 TWO 0.015  
 THREE 0.040  
 WIDTH (FT) LANE

ROAD CONFIGURATION 6

LONGITUDINAL SLOPE (FT/FT)	PERMEAB. (FT/DAY)	R FLOWRATE (CF/DAY)*	T TIME (HOURS)	HO TOTAL HEAD (FT)	L TOTAL LENGTH (FT)
0.005	1000.	13.8	2.17	0.53	12.65
0.010	1000.	13.5	2.54	0.59	14.42
0.015	1000.	13.4	3.01	0.69	16.97
0.020	1000.	13.7	3.47	0.83	20.00
0.025	1000.	14.3	3.88	1.01	23.32
0.030	1000.	15.1	4.21	1.23	26.83
0.035	1000.	16.1	4.48	1.49	30.46
0.040	1000.	17.3	4.70	1.79	34.18
0.045	1000.	18.5	4.87	2.13	37.97
0.050	1000.	19.8	5.00	2.51	41.76
0.055	1000.	21.2	5.11	2.93	45.61
0.060	1000.	22.6	5.20	3.39	49.48

CROSS SLOPE (FT/FT) LANE  
 ONE 0.015  
 TWO 0.0  
 THREE 0.0  
 WIDTH (FT) LANE

\* Q values provided are for one foot width of a drainage layer. The total Q for a specific length of roadway is obtained by multiplying the table value by the length between outlets in feet.

ROAD CONFIGURATION 7

LANE	CROSS SLOPE (FT/FT)	LANE WIDTH (FT)
ONE	0.015	12.
TWO	0.040	12.
THREE	0.0	0.

LONGITUDINAL SLOPE (FT/FT)	K PERMEAB. (FT/DAY)	Q FLOWRATE (CF/DAY)*	T TIME (HOURS)	H0 TOTAL HEAD (FT)	L TOTAL LENGTH (FT)
0.005	1000.	13.6	4.33	1.02	24.74
0.010	1000.	13.5	4.70	1.10	26.79
0.015	1000.	13.7	5.16	1.24	29.79
0.020	1000.	14.1	5.62	1.43	33.42
0.025	1000.	14.8	6.03	1.68	37.47
0.030	1000.	15.6	6.36	1.98	41.83
0.035	1000.	16.6	6.63	2.34	46.41
0.040	1000.	17.7	6.85	2.75	51.15
0.045	1000.	19.0	7.02	3.22	56.01
0.050	1000.	20.2	7.16	3.74	60.97
0.055	1000.	21.6	7.27	4.32	66.01
0.060	1000.	23.0	7.36	4.95	71.11

ROAD CONFIGURATION 8

LANE	CROSS SLOPE (FT/FT)	LANE WIDTH (FT)
ONE	0.015	12.
TWO	0.040	6.
THREE	0.0	0.

LONGITUDINAL SLOPE (FT/FT)	K PERMEAB. (FT/DAY)	Q FLOWRATE (CF/DAY)*	T TIME (HOURS)	H0 TOTAL HEAD (FT)	L TOTAL LENGTH (FT)
0.005	1000.	13.7	3.25	0.77	18.70
0.010	1000.	13.5	3.62	0.84	20.61
0.015	1000.	13.6	4.08	0.96	23.38
0.020	1000.	14.0	4.55	1.13	26.71
0.025	1000.	14.6	4.95	1.34	30.40
0.030	1000.	15.4	5.29	1.60	34.33
0.035	1000.	16.4	5.56	1.91	38.44
0.040	1000.	17.6	5.77	2.27	42.66
0.045	1000.	18.8	5.94	2.67	46.98
0.050	1000.	20.1	6.08	3.12	51.37
0.055	1000.	21.4	6.19	3.62	55.81
0.060	1000.	22.8	6.28	4.17	60.29

\* Q values provided are for one foot width of a drainage layer. The total Q for a specific length of roadway is obtained by multiplying the table value by the length between outlets in feet.

ROAD CONFIGURATION 9

LONGITUDINAL SLOPE (FT/FT)	K PERMEAB. (FT/DAY)	Q FLOWRATE (CF/DAY) *	T TIME (HOURS)	H0 TOTAL HEAD (FT)	L TOTAL LENGTH (FT)
0.005	1000.	10.4	5.74	0.78	25.02
0.010	1000.	10.6	6.27	0.89	27.84
0.015	1000.	11.0	6.91	1.06	31.97
0.020	1000.	11.7	7.51	1.31	36.97
0.025	1000.	12.6	8.02	1.62	42.53
0.030	1000.	13.7	8.41	2.01	48.47
0.035	1000.	14.9	8.72	2.46	54.65
0.040	1000.	16.2	8.96	2.99	61.01
0.045	1000.	17.5	9.15	3.58	67.49
0.050	1000.	18.9	9.30	4.25	74.07
0.055	1000.	20.4	9.41	4.98	80.72
0.060	1000.	21.9	9.50	5.79	87.42

CROSS SLOPE WIDTH LANE

LANE (FT) ONE 12. TWO 12. THREE 0.

ROAD CONFIGURATION 10

LONGITUDINAL SLOPE (FT/FT)	N PERMEAB. (FT/DAY)	Q FLOWRATE (CF/DAY) *	T TIME (HOURS)	H0 TOTAL HEAD (FT)	L TOTAL LENGTH (FT)
0.005	1000.	11.3	7.79	1.27	37.11
0.010	1000.	11.5	8.31	1.40	40.21
0.015	1000.	11.9	8.96	1.61	44.79
0.020	1000.	12.5	9.57	1.91	50.39
0.025	1000.	13.3	10.09	2.29	56.68
0.030	1000.	14.4	10.51	2.76	63.47
0.035	1000.	15.5	10.83	3.31	70.60
0.040	1000.	16.7	11.08	3.95	77.98
0.045	1000.	18.0	11.28	4.67	85.56
0.050	1000.	19.4	11.43	5.48	93.28
0.055	1000.	20.8	11.55	6.37	101.12
0.060	1000.	22.2	11.65	7.35	109.06

CROSS SLOPE WIDTH LANE

LANE (FT) ONE 12. TWO 12. THREE 0.040

\* Q values provided are for one foot width of a drainage layer. The total Q for a specific length of roadway is obtained by multiplying the table value by the length between outlets in feet.

A P P E N D I X B

CONSTRUCTION AND MATERIAL SPECIFICATION  
FOR  
BSOG (BITUMINOUS STABILIZED OPEN GRADED) DRAINAGE LAYER,  
NSOG (NON-STABILIZED OPEN GRADED) DRAINAGE LAYER  
AND  
SUBSURFACE DRAINAGE COLLECTORS

The specifications given in this appendix make reference to other specification sections included in the NJDOT Standards for Road and Bridge Construction. Non-New Jersey agencies should cite appropriate provisions from their own standard specifications. To aid in making the necessary substitutions, the specification references given in this appendix are described here. They are listed in order of their appearance in the appendix.

1. Subsection 901.04 - Broken Stone - specifies geologic etc. characteristics of crushed stone.
2. Section 990 - Methods of Tests - specifies new falling head permeability and modified compaction tests for O.G. materials. These specifications are available in Appendix C and D.
3. Subsection 203.04 - Equipment - specifies equipment such as rollers, compactors, etc.
4. Subsection 208.04 - Preparation of Subbase and Subgrade - specifies placing and preparation methods for subbase materials.
5. Subsection 902.02 - Cutback Asphalts - specifies prime coat materials.
6. Subsection 404.13 - Conditioning of Existing Surface - specifies condition of the base course prior to placement of overlying material.
7. Subsection 302.09 - Tolerances - specifies permissible thickness tolerances.
8. Subsection 105.19 - Maintenance - specifies contractors' obligations to maintain all aspects of the construction work in an acceptable condition until the project is accepted by the NJDOT.

9. Subsection 902.01 - Asphalt Cements - specifies asphaltic material characteristics, preparation tests, etc.
10. Subsection 404.04 - Equipment - specifies equipment necessary for construction of bituminous concrete pavements.
11. Subsection 404.05 - Bituminous Concrete Batch Plants - specifies handling preparation and storage etc. of bituminous concrete materials.
12. Subsection 404.11 - Small Tools - specifies handling of tools needed for bituminous sampling and testing.
13. Subsection 404.14 - Transportation and Delivery of Mixture - specifies how bituminous mixtures are to be transported from the plant to the paver.
14. Subsection 404.15 - Spreading and Finishing - specifies placement technique for bituminous mixtures.
15. Subsection 304.13 - Tolerances - specifies surface smoothness requirements for application of bituminous concrete.
16. Subsection 404.19 - Thickness - specifies thickness tolerances of BSOG drainage layer.
17. Subsection 404.21 - Method of Measurement - specifies weighing methods for bituminous concrete.
18. Subsection 904.06 - Temperature-Volume Correction Factors; Table 904-1 Temperature-Volume Correction Factors for Asphalt Products.
19. Subsection 404.02 - Materials - specifies requirements for bituminous materials.
20. Subsection 901.03 - Coarse Aggregate - specifies materials and sizes of coarse aggregate including broken stone, washed gravel, blast furnace slag and boiler slag.

21. Subsection 913.05 - Porous Concrete Pipe - specifies porous concrete pipe for use in underdrains.
22. Subsection 913.07 - Corrugated Aluminum Alloy Underdrain Pipe - specifies perforated aluminum pipes for use in underdrains.
23. Subsection 913.10 - Corrugated Steel Underdrain Pipe - specifies perforated corrugated steel pipes for use in underdrains.
24. Subsection 913.12 - Plastic Drainage Pipe - specifies the plastic pipes allowed in New Jersey underdrains. PVC pipe must conform to ASTM D3034 and have a minimum Standard Dimension Ratio of SDR 35. Polyethylene corrugated drainage pipe must conform to AASHTO M252 and be heavy duty and perforated.
25. Subsection 913.06 - Corrugated Aluminum Alloy Culvert Pipe and Arches - provides specification for corrugated aluminum pipes.
26. Subsection 913.08 - Corrugated Steel Culvert Pipe and Arches - provides specification for corrugated steel pipes.
27. Subsection 919.06 - Filter Fabric - specifies filter fabric allowed for use in New Jersey.
28. Section 914 - Portland Cement Concrete, Mortar and Grout - provides requirements for concrete.
29. Section 207 - Subsurface Structure Excavation - specifies excavation, bedding backfill and compaction requirements for pipes and culverts.
30. Section 602 - Storm Drains - specifies the materials and construction requirements for laying gravity flow pipes.

Division 2 Construction Details

Section 310 - Non-Stabilized Open-Graded Drainage Layer

310.1 Description: Non-stabilized open-graded drainage layer shall consist of blending aggregate in a continuous or batch type plant, transporting the blended material to the site, spreading it on previously prepared subbase to a uniform thickness, grading and compacting to the cross-section shown on the Plans and in accordance with these specifications.

Materials

310.2 Aggregates: The aggregate for the non-stabilized open-graded drainage layer shall be gneiss, argillite, carbonate rock, granite, quartzite or traprock conforming to the requirements of Subsection 901.04.

310.3 Composition of the Mixture: The material for this layer shall consist of crushed aggregate conforming to the following gradation requirements:

<u>Sieve Size, In.</u>	<u>Allowable Percent Passing</u>
1-1/2	100
1	95-100
1/2	60-80
#4	40-55
#8	5-25
#16	0-8
#50	0-5

Material passing the No. 40 sieve shall be non-plastic by AASHTO T90.

The gradation requirements may be attained by using a blend of #57 and #9 stone in an approximate 1:1 ratio.

310.4 Mix Design: The Contractor shall submit for approval a mix design for the material and a statement naming the source of each component.

The job mix formula shall establish the percentage of dry weight of aggregate passing each required sieve size. The values of percent passing each sieve size shall be within the master band. The job mix formula shall be in effect until modification is approved.

The mix design shall be such that when the component sieve sizes are blended together and compacted by the Department's laboratory with a Burmister Table in accordance with ASTM D2049 and modified as in Appendix D and tested for permeability in accordance with Appendix C its permeability will be  $2000 \pm 1000$  feet per day.

310.5 Verification of Mix Design: At least 45 days prior to the production of the non-stabilized open-graded materials, the Contractor shall submit for approval, a mix design and the following quantities of components for material testing and verification that the mix design will result in a mixture having the required permeability:

Blended Aggregate	200 lbs.
or	
Component Size	100 lbs. (each size)

At the Department's option, verification of the mix design may be done on an annual basis provided the properties and proportions of the material do not change appreciably. If a job is the continuation of work in progress during the previous construction season using approved mix designs, and the Contractor verifies in writing that the same source and character of materials are to be used, the Department may waive the requirement for the design and verification of the new mixes. The approved proportions of material will govern during the progress of the work except that the Contractor may switch to another previously approved mix design provided that the Engineer is notified at least three days prior to the change. No change in source or character of any material shall be made until approved by the Engineer, based on the results of tests of the new design mixes or previously approved mix designs using new material.

When unsatisfactory results for any specified characteristic of the work make it necessary, the Contractor may establish a new mix design for approval by the Engineer. In such instances, if the Contractor fails to take corrective action, the Engineer reserves the right to require an appropriate mixture adjustment.

310.6 Equipment: All equipment necessary to mix, transport, place, compact and finish this layer shall be on the project and approved before work will be permitted to start. Such equipment shall include a stationary or portable continuous or batch type pugmill mixer equipped with batching or metering devices for proportioning the blend or other approved units

capable of producing a blended material consistently meeting the gradation requirements, a traveling plant such as a spreader box or asphalt laydown machine capable of maintaining a uniform rate of travel while spreading and of laying a lift of uniform consistency and thickness with proper grade control, motor graders, pneumatic-tired or steel wheeled vibratory rollers and such other equipment and tools as may be required to perform the work in a satisfactory manner. The rollers shall conform to the applicable requirements of Subsection 203.04.

#### Construction Requirements

310.7 Mixing: The crushed aggregates shall be blended together in the proper proportion as specified in the mix design.

Surge hoppers shall be used to supply aggregates for blending to meet the required gradation. The blend shall be handled in such a manner as to prevent contamination, degradation, and segregation.

310.8 Quality Control Testing: The conformance to the mix design gradation will be determined on the basis of samples taken by the Engineer at the construction site after placement and tested in accordance with ASTM D421 and ASTM D422. Samples shall be taken at a rate of one sample per every 150 cubic yards of drainage layer material. The producer shall have a quality control technician available at the plant to ensure that the mix complies with the specified requirements.

310.9 Transportation of Mixture: The blend material shall be hauled to the site in vehicles that will prevent contamination, degradation and segregation of the mixture. The material shall contain at least a 2% moisture content to minimize segregation and degradation.

310.10 Preparation of Subbase or Base Course: Preparation of subbase or base course shall be performed in accordance with the applicable provisions of Subsection 208.04 with following modifications. Prior to placement of the plant mixed aggregates the underlying course shall be covered with filter cloth or a prime coat, moistened with water or stabilized with lime-fly ash or portland cement as required in the Supplementary Specifications.

310.11 Spreading: Plant mixed aggregates should be delivered to the prepared subbase or base course and spread uniformly as possible with a minimum of manipulation to prevent segregation. The aggregate shall be placed in compacted lifts not to exceed 4 inches. Spreader boxes or asphalt laydown machines with automatic grade control shall be used.

310.12 Compaction, Shaping and Finishing:

(a) Compaction. Pneumatic-tired rollers, or vibratory rollers conforming to Subsection 205.04 shall be used to provide densification of the material. One or more control strips shall be constructed at the beginning of the work for the purpose of determining project compaction requirements. An additional control strip shall be constructed when a change is made in the type or source of material, whenever a change occurs in the composition of the material from the same source, or as directed. Each control strip shall consist of an area of at least 400 square yards, and shall be of the same material as that specified on the remainder of the project.

The control strip shall be compacted by a minimum of two passes with the compaction equipment. A pass is defined as one passage of one tire, compacting wheel, a vibratory unit over the entire surface of the layer. Compaction shall continue until no appreciable increase in density is obtained by additional passes without crushing of aggregate. Density of the control strip shall be determined in accordance with current provisions of AASHTO T238 Method A.

Upon completion of compaction, a minimum of ten tests will be made at random locations to determine the average in-place density of the control strip. The value of this average shall be the reference maximum density for non-stabilized open-graded drainage layer material from the same source used elsewhere on the project.

For the purpose of monitoring conformance to the compaction requirements, the non-stabilized open-graded drainage layer constructed on the project shall be divided by the Engineer into lots consisting of approximately 5,000 square yards or less of area.

The Engineer shall determine the average lot density of five randomly selected locations in the lot. This average lot density shall not be less than 95% of the average reference maximum density in the control strip. If a lot fails to meet this requirement it shall be recompacted by the Contractor at his expense and shall be resubmitted for acceptance. The Engineer will determine the new average lot density. If this density still fails to meet 95% of the average reference maximum density, a new control strip will be constructed.

(b) Shaping and Finishing. After the mixture has been compacted the surface shall be shaped to the required cross-sections. Prior to placement of subsequent bituminous material, the non-stabilized open-graded material shall be covered with a prime coat materials conforming to Subsection 902.02 and 404.13.

310.13 Tolerances: The surface and thickness tolerances shall be as stated in Subsection 302.09, except that  $\pm 1/4$ " shall be used as the surface tolerance, low areas shall be corrected by adding material, grading and compacting. The thickness tolerances shall be  $\pm 1/2$ ". Thin areas will be corrected by adding material, grading and compacting.

310.14 Maintenance Under Traffic: Maintenance shall be performed as provided under Subsection 105.19. During the construction of the drainage course and until the Contractor has entirely covered the course with pavement or other "sealing" layers, it shall be the Contractor's responsibility to maintain drainage of the job site such that fine material is not allowed to wash into and clog any part of the drainage system. Any area of the drainage course for which the drainage becomes impaired during construction shall be reconstructed.

Only that equipment necessary for the construction of the next higher pavement course shall be allowed on the drainage layer.

Compensation

310.15 Method of Measurement: The non-stabilized open-graded drainage layer of the thickness shown on the Plans will be measured by the square yard as determined from dimensions shown on the Plans or as established by the Engineer. Non-stabilized open-graded drainage layer of variable thickness will be measured by the cubic yard. The accepted quantity of prime coat for which payment will be made will be the number of gallons used, corrected to 60<sup>0</sup>F, as determined by the temperature volume corrections specified in Table 902-02, Subsection 902.02.

310.16 Basis of Payment: The accepted quantity of non-stabilized open-graded drainage layer of the thickness specified on the Plans will be paid for at the contract unit price per square yard complete in place, as specified. Should variable thickness be specified, payment will be at the contract unit price per cubic yard.

Payment will be made under:

<u>Item No.</u>	<u>Pay Item</u>	<u>Pay Unit</u>
310.01	Non-Stabilized Open-Graded Drainage Layer, _____" Thick	Square Yard
310.02	Non-Stabilized Open-Graded Drainage Layer, Variable Thickness	Cubic Yard
404-04	Prime Coat	Gallon

Division 2 Construction Details

Section 311 - Bituminous-Stabilized Open-Graded Drainage Layer

311.1 Description: Bituminous-stabilized open-graded drainage layer shall consist of mixing the aggregate and bitumen in a continuous or batch type plant, transporting the mixture to the site, spreading in on previously prepared subbase to a uniform thickness, grading and compacting to the cross-section shown on the Plans and in accordance with these specifications.

Materials

311.2 Aggregate: The aggregate used in this construction shall be gneiss, argillite, carbonate rock, granite, quartzite or traprock conforming to the requirements of Subsection 901.04

311.3 Bituminous Material: The bituminous material shall be asphalt cement conforming to the requirements of Subsection 902.01 for grade AC-20 or AC-10 unless otherwise directed.

311.4 Anti-Stripping Agent: A heat-stable, anti-stripping additive satisfactory to the Engineer shall be used.

311.5 Composition of the Mixture: The bituminous-stabilized open-graded material shall consist of bitumen, anti-stripping agent and aggregate conforming to the following gradation requirements:

<u>Sieve Size, In.</u>	<u>Allowable Percent Passing</u>
1	100
3/4	95-100
1/2	85-100
3/8	60-90
#4	15-25
#8	2-10
#16	2-5
#200	*

\*Add 2% (by weight of total mix) mineral filler.

The bitumen content shall be  $3 \pm 1/2$  percent by weight of dry aggregate and mineral filler.

311.6 Mix Design: The Contractor shall submit for approval, a job mix formula for the material and a statement naming the source of each component.

The job mix formula for the mixture shall establish the percentage of dry weight of aggregate passing each required sieve size and the percentage of asphalt cement based upon the weight of the total mix. The values of percent passing each size shall be within the master gradation band of Subsection 311.5. The job mix formula shall be in effect until modification is approved.

The mix design shall be such that when the component aggregates are blended together, mixed with the specified amount of bitumen and anti-stripping agent at a temperature of 250<sup>0</sup>F and compacted at the

Department's laboratory with an Instron machine at 600 psi for carbonate rock aggregate and 1000 psi for aggregates of all other stone types according to ASTM D1074 and Appendix D and tested for permeability according to Appendix C its permeability will be  $2000 \pm 1000$  feet per day.

311.7 Verification of Mix Design: At least 45 days prior to the production of the bituminous open-graded materials, the Contractor shall submit for approval, a mix design and the following quantities of components for material testing and verification that the mix design will result in a mixture having the required permeability:

Blended Aggregate	200 lbs.
Bituminous Material	1 Gallon
Anti-Stripping Agent	1 Quart
Mineral Filler	25 lbs.

At the Department's option, verification of the mix design may be done on an annual basis provided the properties and proportions of the material do not change appreciably. The approved proportions of material will govern during the progress of the work except that the Contractor may switch to another previously approved mix design provided that the Engineer is notified at least one day prior to the change. No change in source or character of any material shall be made until approved by the Engineer, based on the results of tests of the new design mixes or previously approved mix designs using the new material.

When unsatisfactory results for any specified characteristic of the work make it necessary, the Contractor may establish a new mix design for approval by the Engineer. In such instances, if the Contractor fails to take corrective action, the Engineer reserves the right to require an appropriate mixture adjustment.

311.8 Equipment: All equipment necessary for the satisfactory performance of this construction shall be on the project and approved before work will be permitted to start. In general, the equipment shall conform to the applicable requirements of Subsection 404.04 and 404.05 through 404.11 (except that equipment for Marshall Method of Stability is not necessary).

#### Construction Requirements

311.9 Limitations: The limitation prescribed in Subsection 404.12 shall apply to this construction with the following additions:

The subbase or base course shall be checked and approved far enough in advance of spreading the bituminous mixture to permit one day's paving operation, exception being permitted at the discretion of the Engineer. The laydown temperature will be  $250 \pm 10^{\circ}\text{F}$ .

311.10 Preparation of Subbase or Base Course: Preparation of the subbase, or base course shall be performed in accordance with the applicable provisions of Subsection 208.04.

311.11 Preparation of Bituminous Mixtures: The dried aggregates shall be combined in the mixer in the amount of each fraction of aggregates required to meet the job mix formula. The bituminous material shall be weighed or metered and introduction into the mixer in the amount specified.

The temperature of the mixture at the discharge from the plant or surge and storage bins shall be maintained at a minimum of 15 degrees above the laydown temperature. In no case shall the mixture temperature exceed 300°F.

311.12 Quality Assurance Testing:

(a) Conformance to Job Mix Formula: The conformance to the job mix formula will be determined on the basis of extraction samples taken and tested at the mixing plant for manual batch plants and will be determined by plant printout tickets and hot bin samples for fully automated batch plants. If samples are found to be outside the master gradation band on any sieve or bitumen content, the producer shall correct the deficiency before continuing production.

(b) Sampling and Testing: Sampling rates and testing for bitumen content and conformance to gradation master band for manual and automated batch plants and drum mix plants shall be in accordance with Subsection 903.03 with the following exceptions:

For process control purposes at manual batch plants, the producer's quality control technician will sample and determine the gradation of the aggregate components in the hot bin at least twice daily during

continuous production of bituminous-stabilized open-graded materials. At drum mix plants this process control sampling and testing shall be performed on material in the cold bins. The resulting bin gradations shall be theoretically combined using the job mix formula bin pulls to determine if changes are needed in the aggregate blending process. Process changes shall be made by the producer to keep the mixture in gradation control.

311.13 Transportation of Mixture: Transportation and delivery of the mixture shall be as prescribed in Subsection 404.14.

311.14 Spreading and Finishing: Prior to placement of the bituminous material, the underlying course shall be covered with filter cloth or a prime coat, moistened with water or stabilized with lime-fly ash or portland cement as required in the Supplementary Specifications. Spreading and finishing the mixture shall conform to the requirements of Subsection 404.15 except that paving full width of the roadway or paving in echelon need not apply. The mixture shall be placed in compacted lifts not to exceed 4 inches. No tack coat shall be placed between subsequent layers or to the surface of the drainage layer prior to placement of subsequent lifts of bituminous concrete pavement.

311.15 Compaction: Three-wheeled or vibratory rollers conforming to Subsection 404.09 shall be used to provide densification of the material.

The drainage layer shall be compacted in accordance with the provisions of Subsection 404.16. One or more control strips shall be constructed at the beginning of the work for the purpose of determining project compaction requirements. An additional control strip shall be constructed when a change is made in the type or source of material, whenever a change occurs in the composition of the material from the same source, or as directed. Each control strip shall consist of an area of at least 400 square yards, and shall be of the same material and thickness as that specified on the remainder of the project.

The control strip shall be compacted by a minimum of two passes with the compaction equipment. A pass is defined as one passage of one tire, compacting wheel, or vibratory unit over the entire surface of the layer. Compaction shall continue until no appreciable increase in density is obtained by additional passes. Density of the control strip shall be determined in accordance with current provisions of AASHTO T238, Method A.

Upon completion of compaction, a minimum of ten tests will be made at random locations to determine the average in-place density of the control strip. The value of this average shall be the reference maximum density for bituminous-stabilized open-graded drainage layer material from the same source used elsewhere on the project.

For the purpose of monitoring conformance to the compaction requirements, the bituminous-stabilized open-graded drainage layer constructed on the project shall be divided by the Engineer into lots consisting of approximately 5,000 square yards or less of area.

The Engineer shall determine the average lot density of five randomly selected locations in the lot. This average lot density shall not be less than 95% of the average reference maximum density in the control strip. If a lot fails to meet this requirement, a new control strip will be constructed.

311.16 Tolerances:

(a) Surface Requirements: Shall be in accordance with Section 304.13.

(b) Thickness: The thickness of the drainage layer shall conform to the requirements of Subsection 404.19, except that payment adjustments for deficient thickness shall not apply.

311.17 Maintenance Under Traffic: Maintenance shall be performed as provided under Subsection 105.19. During the construction of the drainage course and until the Contractor has entirely covered the course with pavement or other "sealing" layers, it shall be the Contractor's responsibility to maintain drainage of the job site such that fine material is not allowed to wash into and clog any part of the drainage system. Any area of the drainage course for which the drainage becomes impaired during construction, shall be reconstructed.

Only that equipment necessary for the construction of the next higher pavement course shall be allowed on the drainage layer.

Compensation

311.18 Method of Measurement: The bituminous-stabilized open-graded

drainage layer shall be measured by the ton as determined by one of the methods outlined in 404.21.

The accepted quantity of asphalt cement for which payment will be made will be the product of the asphalt content percentage in the approved job mix formula and the tonnage of bituminous concrete accepted and complete in place. The accepted quantity of prime coat for which payment will be made will be the number of gallons used, corrected to 60°F, as determined by the temperature volume corrections specified in Table 902-2, Subsection 902.02.

311.19 Basis of Payment: The accepted quantity of bituminous-stabilized open-graded drainage layer will be paid for at the contract unit price per ton of mixture accepted and complete in place.

Payment for asphalt cement will be made for the quantity as above determined measured in tons, at the price per ton bid for the item asphalt cement in the proposal, which price and payment will be full compensation, for furnishing all asphalt cement necessary to complete the item.

Payment for prime coat will be made for the quantity as above determined, measured in gallons, at the contract unit price per gallon, which price and payment will be full compensation, for furnishing and applying prime coat as required.

Payment will be made under:

<u>Item No.</u>	<u>Pay Item</u>	<u>Pay Unit</u>
311.01	Bituminous-Stabilized Open-Graded Drainage Layer	Ton
404-02	Asphalt Cement	Ton
404-04	Prime Coat	Gallon

Section 619 - Subsurface Drainage Collectors

619.01 Description. This work shall consist of the construction of collector drains and outlets for subsurface drainage layers.

Materials

619.02 Materials. Materials shall conform to the following

Subsections:

Coarse Aggregate (for backfill)	901.03
Porous Concrete Pipe	913.05
Corrugated Aluminum Alloy Underdrain Pipe	913.07
Corrugated Steel Underdrain Pipe	913.10
Plastic Drainage Pipe	913.12
Corrugated Aluminum Alloy Culvert Pipe and Arches	913.06
Corrugated Steel Culvert Pipe and Arches	913.08
Filter Fabric	919.06

Portland cement for plugging pipes shall conform to Section 914 for miscellaneous concrete.

Construction

619.03 Excavation and Backfill. Excavation and backfilling of trenches shall be in accordance with Section 207 and the following:

Prior to commencement of the trench excavation the subbase shall have been stabilized where designated, compacted and brought to the grade of the bottom of the open-graded drainage course as shown on the plans. Materials from the trench excavation shall not be placed on prepared subbase, nor shall it be placed such that it may interfere with any subsequent filter fabric placement, nor in such a manner that it may be carried into the trench backfill material.

The bottom width of the trench shall be of such width that a 6" of clearance is provided between the trench walls, and the sides of the pipe. Backfill of the collector pipes shall be with either #8 or #57 coarse aggregate. Backfill for outlet pipes shall be with material excavated from the trench. All backfill for underdrain collector pipes and outlet pipes shall conform to Section 207 and the following:

Compaction shall begin with the first 6 inches of material placed over the pipe and shall then continue in 6 inch lifts for the remaining backfill.

619.04 Placing Filter Fabric. Filter fabric shall be placed to encapsulate the entire trench prior to placing pipe and backfill. A flap of filter fabric with a minimum width of 3'6" along the outer edge of the trench shall be secured to completely cover the top of the trench until just prior to constructing the drainage base course, at which time the filter fabric which covers the top of the trench shall be folded back.

619.05 Laying Pipe

Laying pipe shall be in accordance with Section 602 and the following:

Prior to placing collector pipes, 3" of the chosen backfill aggregate shall be placed and leveled to conform with the invert elevations of the pipe.

Dead ends of the underdrain collectors shall be closed with a pipe cap or plugged with concrete.

After the pipe has been laid, the backfilling shall be done so that the pipe will not become damaged or displaced. Outlet pipes shall be metal or concrete, non-perforated or non-porous pipes.

Compensation

619.06 Method of Measurement

Subsurface drainage collector and outlet pipes will be measured by the linear foot along the centerline of the pipe.

619.07 Basis of Payment

Payment will be made under:

Contract Item	Unit
Subsurface Drainage Collector	Linear Foot

Payment for outlet pipes will be made in accordance with Section 602.

Payment for rock excavation will be made in accordance with Section 207.

A P P E N D I X C

FALLING HEAD PERMEABILITY TEST

FOR

OPEN GRADED MATERIALS

## Falling Head Permeability Test for Open-Graded Materials

### 1.0 Scope:

This method describes a test and related equipment for determining the permeability of open-graded materials. This test can be used with confidence on materials having a "K" value ranging from 100 to 20,000 feet/day.

### 2.0 General:

This test and equipment were developed to replace standard falling head permeameters for use in testing open-graded materials. What resulted from trial and error was a permeability test method which gives reasonable repeatability and can be quickly assembled and disassembled - a desirable feature where a large number of samples are slated for testing.

The permeameter itself can be easily fabricated from commonly available materials. The dimensions suggested here were found to be convenient for use with the materials available to the researcher, and are given as a guide. It is necessary, however, to allow for a large enough standpipe to enable an accurate determination of the drop time.

It is important to realize that this test does not give the exact "K" value for a given material. Head losses and other variables make determination of an absolute "K" improbable. However, constant head full-scale permeability tests substantiated the validity of this test method. The "K" values obtained from this test are somewhat conservative and hence should be applicable to engineering problems.

3.0 Apparatus: (see Figures #C1 and #C2)

3.1 Mold - A 8.5" high x 4" I.D. steel mold, with a #16 standard sieve screen silver soldered to the bottom of the cylinder as shown in Figure #C2 is used with unstabilized open-graded material. The same mold without a screen mesh is used for bituminous-stabilized samples.

3.2 Standpipe - A 22" high x 4" I.D. plastic pipe with a 1/2" diameter hole located 15.75" from the top and sealed with clear plexiglas to allow viewing of the water drop. If clear plastic is used for the standpipe, no view port is necessary.

3.3 Rubber Collar - A 4" wide x 16" long strip secured with two stainless steel hose clamps of rubber join the mold and the plastic standpipe.

3.4 Water Supply - A source of clear water capable of supplying a minimum of five to six gallons/minute should be available.

3.5 Stopwatch - A stopwatch capable of measuring up to 30 minutes with an accuracy of  $\pm 0.1$  second should be available.

3.6 Steel Ruler - A steel ruler with 1/100 of an inch gradations should be available.

4.0 Test Procedure:

4.1 The sample should weigh approximately 1600 grams and shall be properly compacted in the cylinder mold as described and shown in Appendix D. On top of the mold the plastic standpipe should be secured by a rubber collar as shown in Figure #C1. In this way, the assembled permeameter should be placed on a surface such as the bottom of a sink, to provide first retention

and later drainage of water. Fill the standpipe with water to overflowing or to a predetermined height. To start water flow, immediately lift the permeameter two to three inches from the surface while starting to time the flow with a stopwatch. Stop the watch and record the time when the water level reaches the plexiglas view port or another predetermined mark. Repeat the test two additional times; record the data and average to determine time "T".

Please note that the above is an experimental research procedure and not a finalized test specification, which, however, should be developed with time.

4.2 Calculation of "K" - The falling head permeability value "K" can be calculated easily by the formula:

$$K \text{ (in/sec)} = \frac{L}{T_{\text{avg}}} \times \ln \left( \frac{h_1}{h_2} \right)$$

$$K \text{ (ft/day)} = 7200 \times K \text{ (in/sec)}$$

Note: No temperature corrections are used on these permeability tests, since all tests are run at room temperatures. Corrections for viscosity of water become insignificant when compared to the variations normally encountered in permeability testing of the open-graded material.

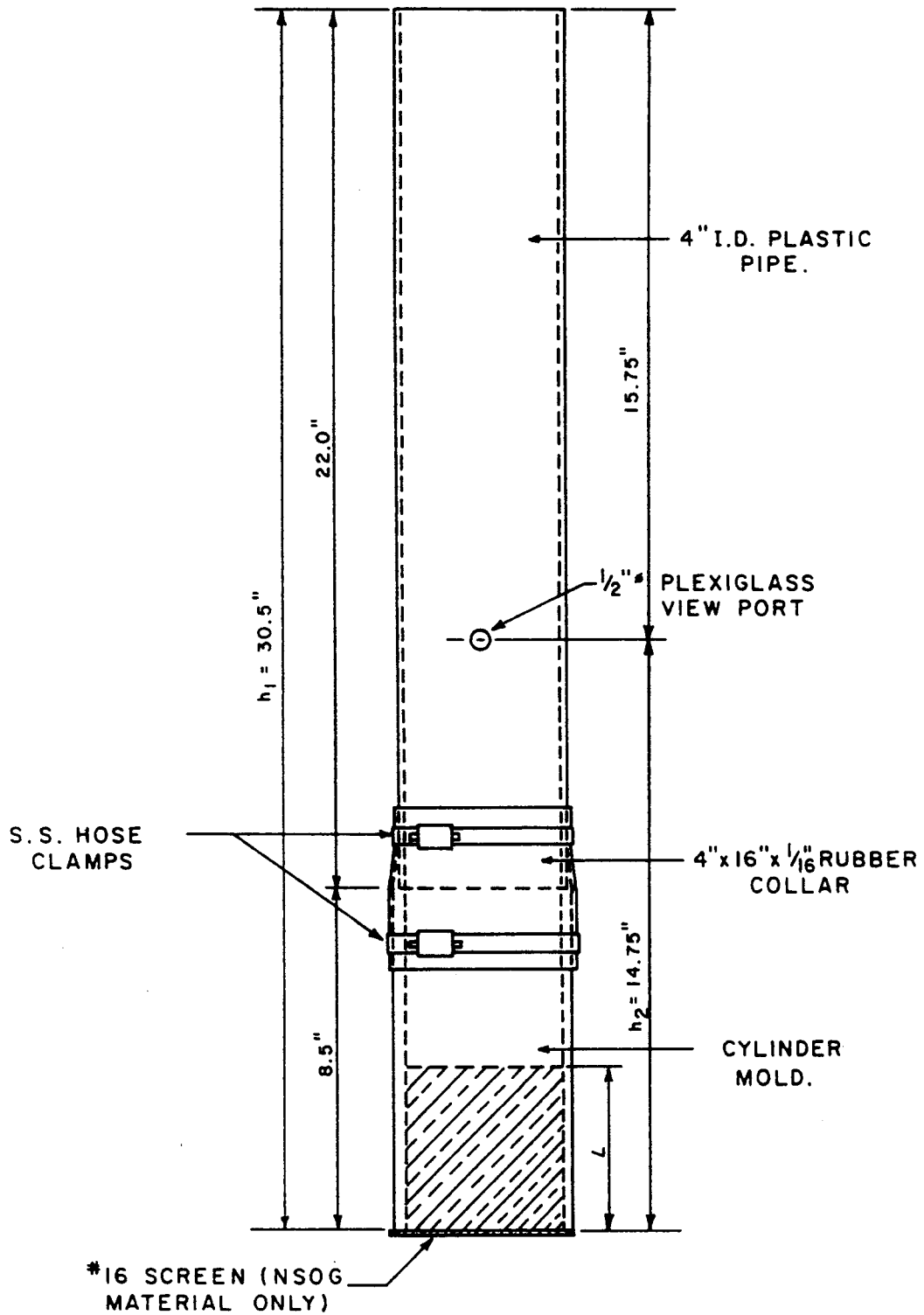

**FIGURE \*C1 MODIFIED FALLING HEAD  
PERMEAMETER ASSEMBLY**

SCALE: 1" = 4"

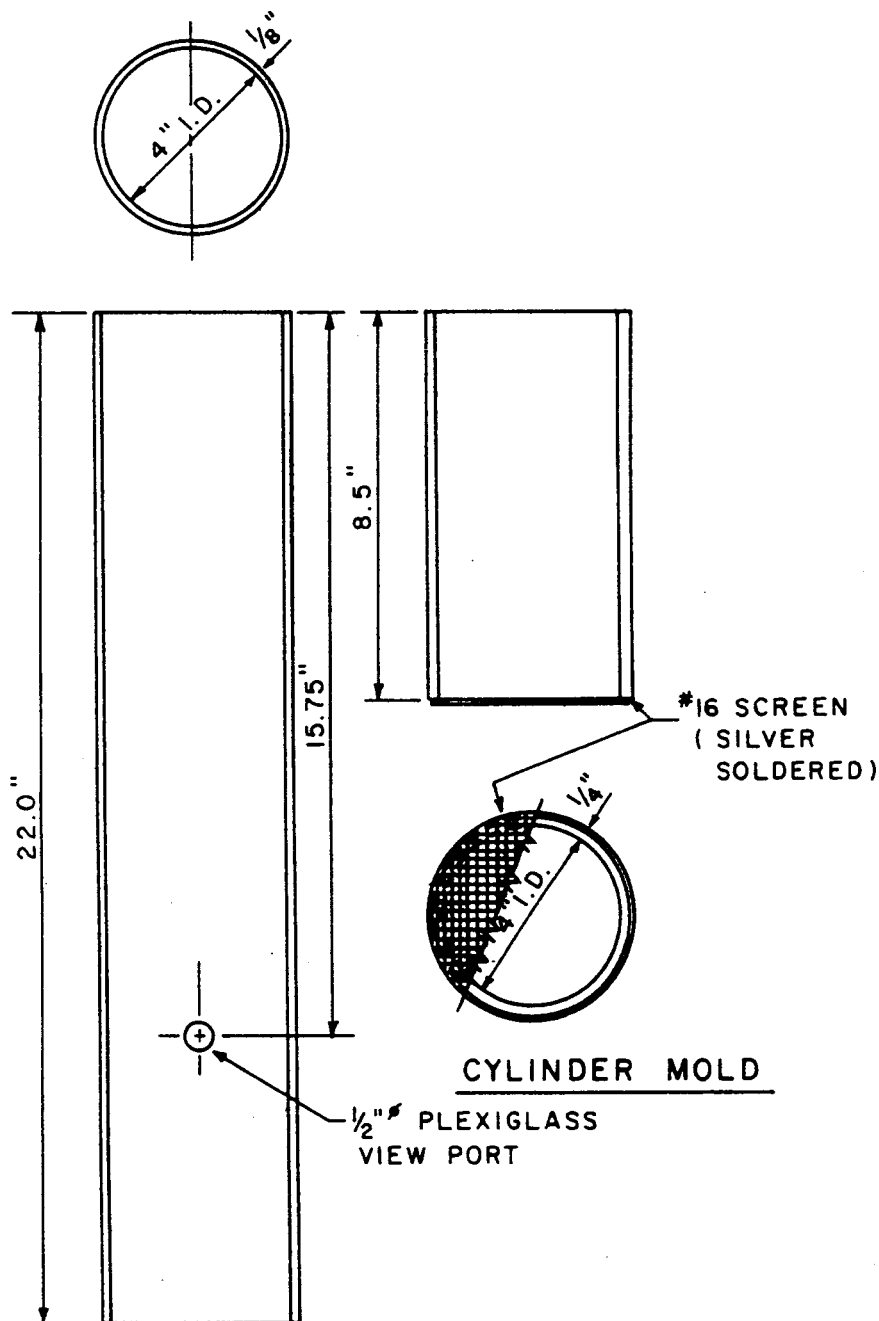

STANDPIPE (IF CLEAR PLASTIC IS USED  
NO VIEW PORT NECESSARY)

FIGURE \*C2 MODIFIED PERMEAMETER ASSESSORIES

SCALE: 1" = 4"

A P P E N D I X D

LABORATORY COMPACTION TESTS AND EQUIPMENT FOR  
BSOG AND NSOG MATERIALS

Compaction of  
Bituminous-Stabilized Open-Graded (BSOG) Materials

1.0 Scope:

This method describes briefly various equipment and procedures pertaining to compaction of BSOG material.

First, a brief description of the apparatus used for laboratory compaction of BSOG is provided, then a procedure for its use is detailed.

2.0 Apparatus: (see Figures #D1 and #D2)

The apparatus for compaction of BSOG materials consists of the following:

2.1 Mechanical Mixer - A Lancaster mixer of small capacity (generally one sample of 5 lbs) is sufficient to blend the stone - AC mix.

2.2 Compaction Apparatus - These apparatus are described and illustrated in ASTM D1074 with the following modifications:

2.2.1 Mold - A 8.5" high x 4" I.D. steel mold as shown in Figure #D2 shall be used.

2.2.2 Top and bottom plungers - Plungers shall have the dimensions as shown in Figure #D2 and shall be made of mild steel.

2.2.3 Half-ring Supports - Two 2" high x 4" I.D. mild steel spacer-supports are used prior to compacting the specimens.

2.2.4 Paper discs - 4 inch in diameter should be available.

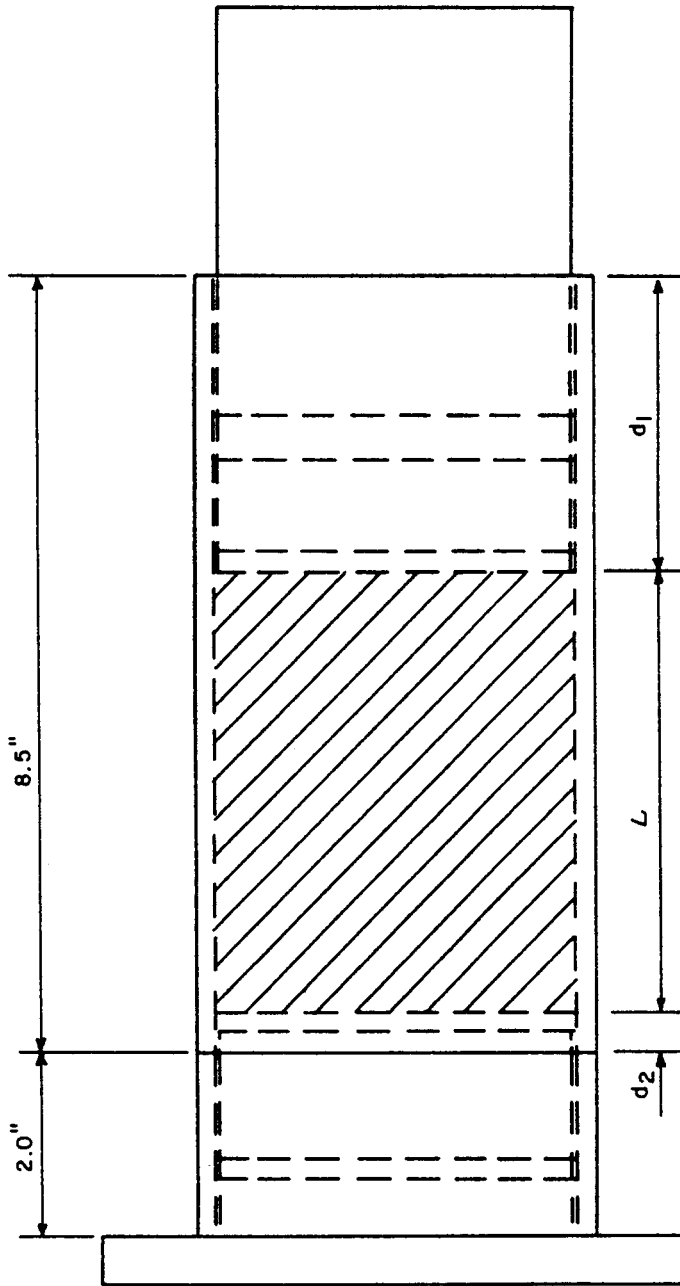
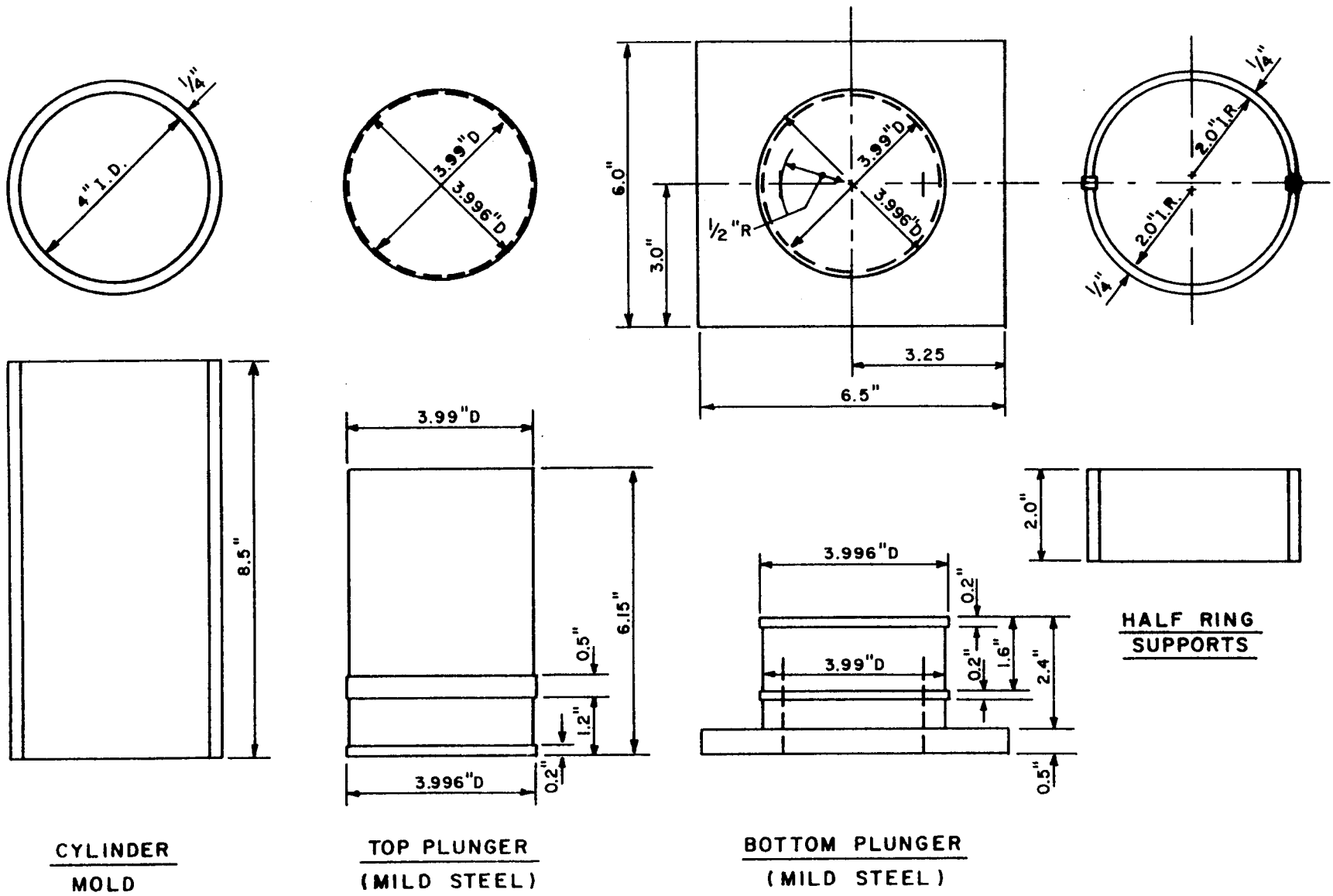

FIGURE \*DI BSOG COMPACTION EQUIPMENT ASSEMBLY.

SCALE :  $1'' = 2''$



CYLINDER  
MOLD

TOP PLUNGER  
(MILD STEEL)

BOTTOM PLUNGER  
(MILD STEEL)

HALF RING  
SUPPORTS

FIGURE #D2 BSOG COMPACTION EQUIPMENT ASSESSORIES.

SCALE : 1" = 3"

### 3.0 Compaction Procedure:

3.1 Sample Compaction - The sample should be approximately 1600 grams and should be compacted to the density expected in actual field conditions.

3.1.1 Weighing of Mix Components - Weigh out predetermined portions of BSOG mix.

3.1.2 Heating of Mix Components - Heat all materials to be blended and the mixing utensils to appropriate temperatures to assure compaction of the mix in the mold at 250<sup>0</sup>F as follows:

- a. Stone to 325<sup>0</sup>F
- b. A.C. to 275<sup>0</sup>F
- c. Mixing utensils and bowls to 325<sup>0</sup>F

If the BSOG mix has already been batched (e.g., samples taken from the field), heat the mix to 300<sup>0</sup>F.

3.2 Mixing Time - The A.C. and stone mix are blended and mixed by a Lancaster mixer for two minutes or until stone is fully covered by A.C., whichever comes first.

3.3 Assemble Mold - Lightly oil mold and plunger components. Place half ring supports and mold on bottom plunger. Insert paper disc into bottom of mold.

3.4 Filling of Sample Mold - The mix is then poured into the mold. This step is done in three stages (three equal lifts). After each stage, the mix is rodded 25 times using a spatula (10 times on the surface of the layer and 15 times around the stone-mold interface). Place a paper disc on sample and insert top plunger.

3.5 Laboratory Compaction Effort - Begin compaction with an Instron Universal testing machine or similar device capable of producing accurate molding pressures up to 2000 psi or 25,000 lbs. total load. Compactive pressures should be limited to those required in the Appendix B specification. Excessive pressures will crush the aggregates and result in variability of subsequent permeability tests. Compaction should follow procedures outlined in ASTM D1074.

#### 4.0 Density Determination:

4.1 Sample Weight - Weigh each mold and record the weight ( $W_M$ ) to the nearest gram. After the sample has been placed in the mold, re-weigh and record  $W_T$  to the nearest gram. The weight of the sample is

$$W = W_T - W_M.$$

4.2 Sample Dimension - Determine the sample dimension from Figure #D1 and Table #D1.

Table #D1, a Compaction and Permeability Data Sheet, can be used as a handy calculation and recording device for both compaction of BSOG mixes and permeability tests of all OG materials.



Compaction of  
Non-Stabilized Open-Graded (NSOG) Materials

1.0 Scope:

This method covers the test and related equipment developed to compact unstabilized open-graded materials (NSOG) to field densities, allowing both a visual inspection of the sample and a permeability test on the specimen.

2.0 General:

Achieving maximum density with cohesionless soils such as NSOG materials presents special compaction problems. Static pressures do little to rearrange particles and achieve proper compaction; standard drop hammers (such as Proctor's or Marshall's) achieve more uniform compaction than static pressure but allow the material to "fluff" and loosen around the hammer. To overcome these difficulties Burmister developed a vibratory method of compaction using a specified surcharge on the sample. The Burmister method is incorporated into ASTM specification (ASTM D-2049), as a method of testing granular soils with little or no cohesion, for maximum density.

To study NSOG materials the Burmister's equipment and test methods were modified. Basically, the vibrating table specified by ASTM remains unchanged. However, to allow observation of the compacted sample, the density mold was constructed of clear plexiglas instead of steel, and fastened to the vibrating table with plywood retainers, threaded rods and wing nuts as shown in Figures #D3 and #D4.

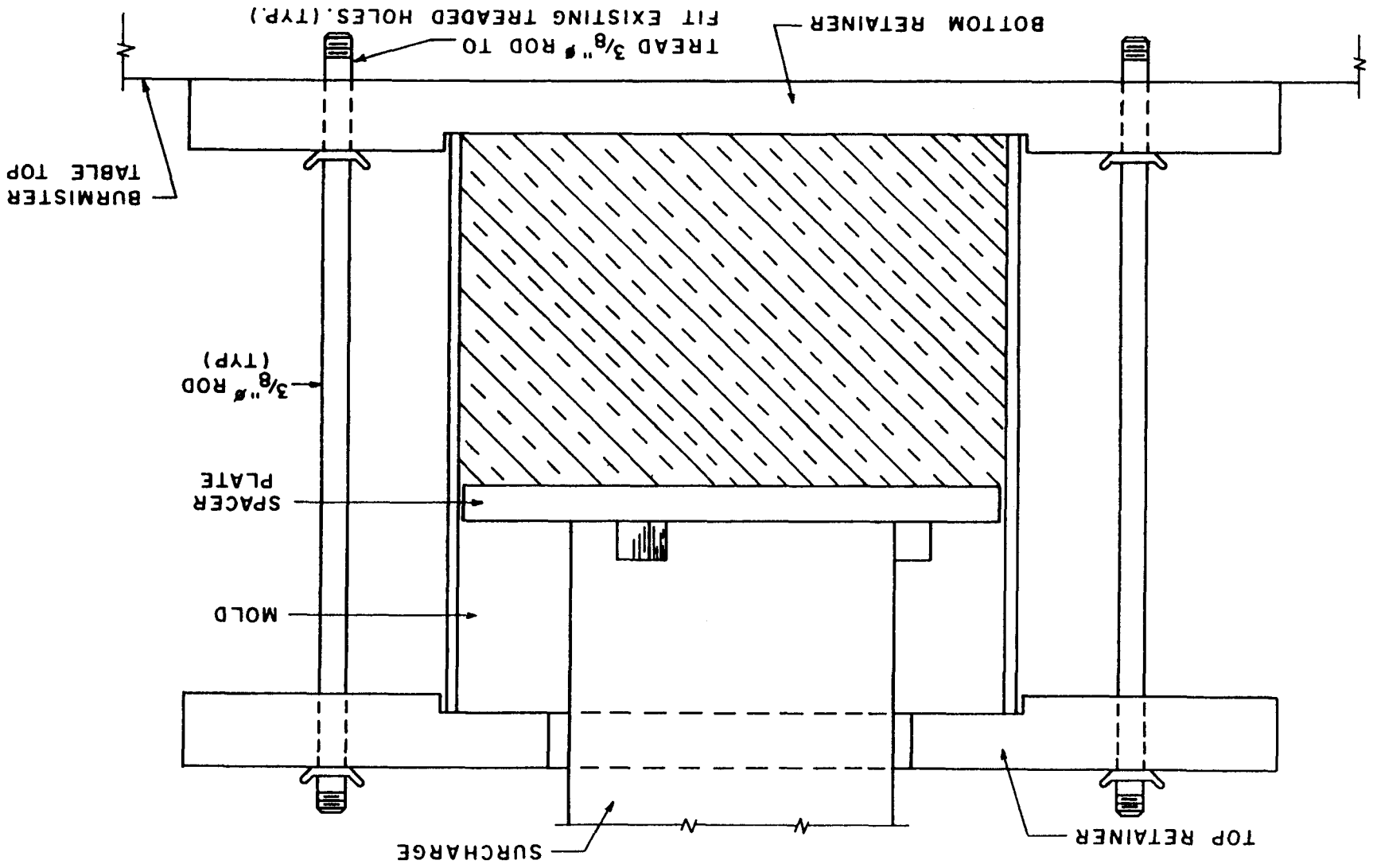

FIGURE #D3 MODIFIED BURMISTER EQUIPMENT ASSEMBLY.  
 SCALE: 1" = 2"

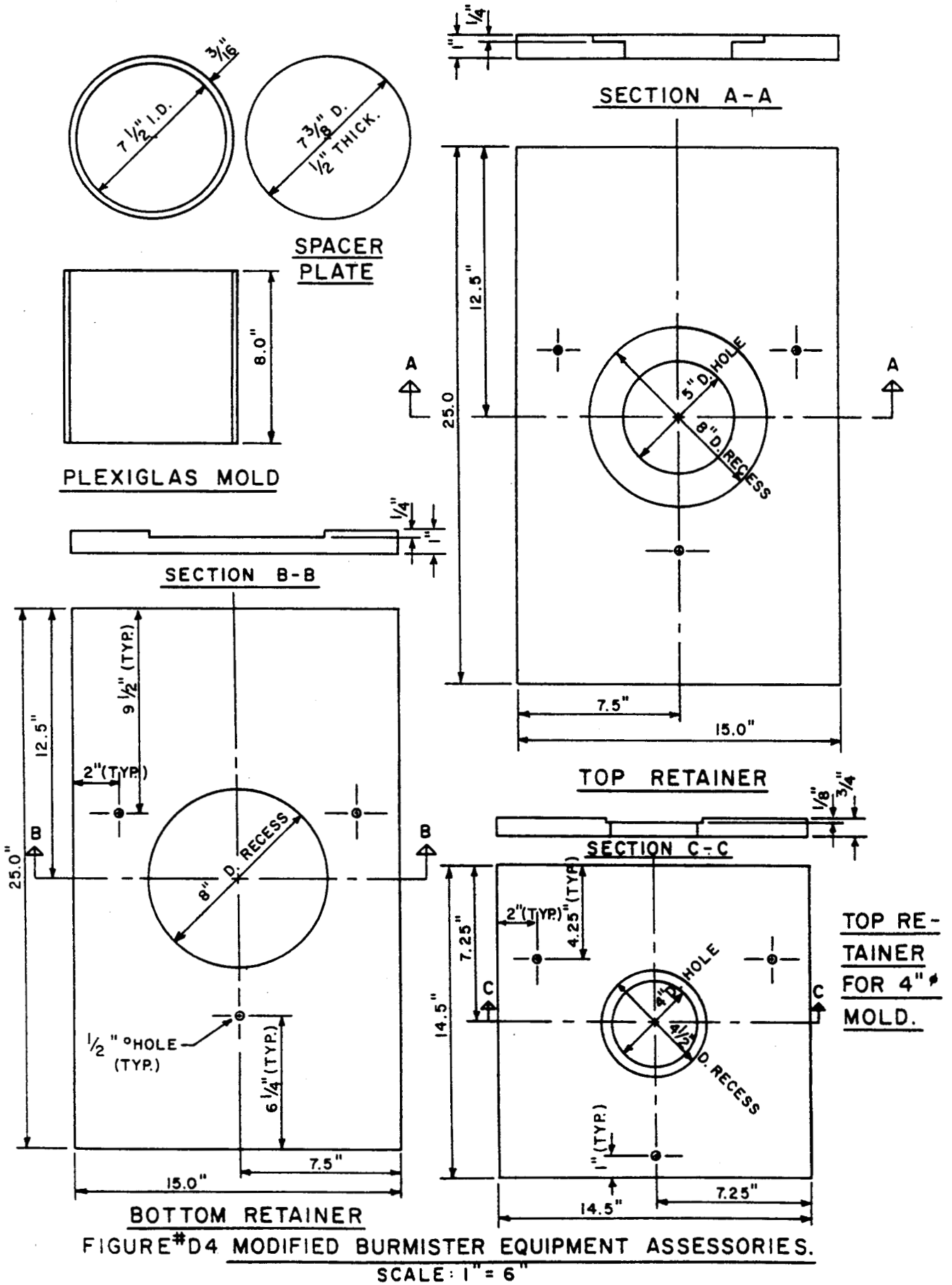

FIGURE #D4 MODIFIED BURMISTER EQUIPMENT ASSESSORIES.  
SCALE: 1" = 6"

3.0 Apparatus: (see Figures #D3 and #D4)

3.1 Vibrating Table - A Burmister vibratory table meeting ASTM D-2049 specification provides the required vibrational energies.

3.2 Plexiglas Mold - A plexiglas cylinder 8" high x 7.5 " diameter and 3/16" thick. This mold is used to study both the density and the integrity (lack of segregation) of the samples. The mold is capable of holding 15 pounds of uncompacted NSOG materials. This apparently large sample size appears to be essential in obtaining a representative density result.

3.3 Plywood Retainers and Threaded Rods and Wing Nuts (see Figures #D3 and #D4) - In order to prevent the mold from shifting on the vibrating table, plywood retainers are fitted over and under the plexiglas mold. The bottom retainer has a 1/4" deep recess slightly larger than the O.D. of the plexiglas cylinder. The mold is placed into this recess to prevent lateral movement during vibrating.

The top retainer is similar to the bottom with the exception of the 5" diameter hole through which the surcharge is placed. Again, a 1/4" deep recess is routed out to restrain the movement of the mold. The entire assembly is locked to the vibrating base by three 3/8" diameter threaded rods with wing nuts. Location of predrilled holes on the table determine placement of 3/8" diameter rods and the size of the retainer plates. Please note that the above research procedure is offered as a guide.

3.4 Spacer Plate - A plywood disc 7-3/8" in diameter and 1/2" thick is placed in the mold on the sample. The spacer prevents the surcharge from sinking into the samples at an uneven rate during compaction.

3.5 Surcharge - A 50# surcharge is used with the large plexiglas density mold. An eye bolt attached to the weight permits easy lifting with a block and tackle.

For permeability samples (4" mold) a 12# surcharge is used. This surcharge places the same force on the 4" samples as the 50# surcharge places on the large sample.

3.6 Scale - A heavy duty scale capable of weighing samples up to 20 kg with an accuracy  $\pm 1$  gram is used.

3.7 Steel Ruler - To measure sample height use a steel ruler with gradations of 1/100 of an inch.

3.8 Stopwatch - A stopwatch capable of 0.1 second accuracy is used to measure the time of vibration.

#### 4.0 Procedure:

4.1 Density Molds - Place the bottom retainer on the Burmister table and secure it to the table with threaded rods and wing nuts. Set the plexiglas mold into the recess of the retainer. Weigh out 15# of sample to the nearest gram and carefully - so as to avoid segregation, place the sample loosely into the mold and level the surface. Place the spacer plate on the sample and fit the top retainer plate over the threaded rods and cylinder. Inspect the retainer plates to be certain the mold is secure in the recess. Secure the top retainer with the wing nuts. Measure and record to the nearest .01" the height of the sample at 4 points on the sample. Average this result. Lower the surcharge to sit

freely on the spacer plate and begin vibrating the sample for 30 seconds at an amplitude of 50 on the scale described in ASTM D2049. Remove the surcharge and measure the compacted height of the sample.

4.2 Permeability Mold - Follow the same procedure outlined above, except that 4" diameter mold is seated on the same bottom retainer while on the top a suitable retainer shown in Figure #D4 is used.

#### 5.0 Calculations:

Calculate the density of the samples as follows:

$$\frac{W_{\text{sample}}}{V_{\text{sample}}} = \text{Density in PCF}$$

where:

W is the weight of the sample in pounds

V is the volume of the compacted sample in cubic feet

#### 6.0 Visual Evaluation Note:

An empirical evaluation to classify samples as either "good" or "bad" according to amount of segregation and voids, and the overall appearance of the mix can be developed using this method.