

SECOND GENERATION PAVEMENT OVERLAYS

A Final Report

By
E. J. Hellriegel
Project Engineer

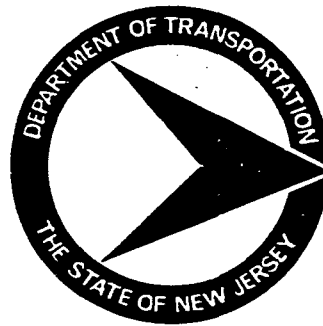

JULY, 1987

Prepared By
New Jersey Department of Transportation
Bureau of Transportation Structures Research

In Cooperation With
U.S. Department of Transportation
Federal Highway Administration

Disclaimer Statement

The contents of this report reflect the views of the author(s) who is (are) responsible for the facts and the accuracy of the data presented herein. The contents do not necessarily reflect the official views or policies of the New Jersey Department of Transportation or the Federal Highway Administration. This report does not constitute a standard, specification, or regulation.

1. Report No. FHWA/NJ-86-013-7778		2. Government Accession No.		3. Recipient's Catalog No.	
4. Title and Subtitle Second Generation Pavement Overlays				5. Report Date July 1987	
				6. Performing Organization Code	
7. Author(s) Edgar J. Hellriegel, Project Engineer				8. Performing Organization Report No. 86-013-7778	
9. Performing Organization Name and Address Division of Research and Demonstration New Jersey Department of Transportation 1035 Parkway Avenue Trenton, NJ 08625				10. Work Unit No. (TRAIS)	
				11. Contract or Grant No. NJ HPR Study 7778	
12. Sponsoring Agency Name and Address New Jersey Department of Transportation 1035 Parkway Avenue Trenton, NJ 08625				13. Type of Report and Period Covered Final Report	
				14. Sponsoring Agency Code	
15. Supplementary Notes Prepared in cooperation with the Federal Highway Administration, U.S. Department of Transportation, Washington, D.C.					
16. Abstract <p>The results of a ten-year study designed to develop improved design and construction techniques for resurfacing previously overlaid pavements are presented. The four major topics addressed are milling, recycling, reflection crack control, and resetting manholes and inlets.</p> <p>At this writing, two of these techniques -- milling and recycling -- are of course an accepted part of the state-of-the-art. The discussion presented on these subjects is thus primarily useful for historical purposes.</p> <p>The third technique discussed -- the weakened plane or "saw-and-seal" procedure for preventing reflection cracking -- while less widely known, is now employed in a number of states. The results of this study indicate that when properly applied, the weakened plane technique affords a positive means of preventing reflection cracks in overlays constructed over concrete pavements.</p> <p>The fourth major study topic -- procedures for resetting manholes and inlets prior to overlays -- describes the development of an improved resetting system based on the use of epoxy-bonded, cast-iron extension units. This procedure has been shown to markedly reduce the required time of construction, with consequent significant savings in construction costs and reductions in motorist delay time and discomfort.</p> <p>During the course of the research, each of the described techniques has become standard practice in New Jersey. Specifications and implementation packages developed to facilitate the adoption of the improved practices are presented as appendices.</p>					
17. Key Words Bituminous overlays, milling recycling, resetting manholes and inlets, reflection cracking			18. Distribution Statement Copies available on request.		
19. Security Classif. (of this report) Unclassified		20. Security Classif. (of this page) Unclassified		21. No. of Pages	22. Price

TABLE OF CONTENTS

	<u>Page</u>
PREFACE	1
IMPLEMENTATION STATEMENT	3
SECTION I	
INTRODUCTION	5
SECTION II	
BACKGROUND AND SCOPE OF WORK	7
SECTION III	
OBJECTIVE AND SPECIFIC AIMS	9
SECTION IV	
RESEARCH METHODOLOGY	10
A. Removal by Milling	10
B. Planing, Scarification, and Repavement	11
C. Partial Pavement Removal and Replacement with a Dense Graded Mix	12
D. Pavement Removal and Replacement with an Open Graded Asphalt Friction Course	12
E. Discussion of Equipment Selection	13
F. Manhole, Inlet, and Utility Frames	14
G. Reflection Cracking	16
SECTION V	
DETAILS OF INVESTIGATION	18
A. Milling (Hot)	18
1) Rate and Cost of Milling	19
2) Skid Resistance of Milled Surface	21
3) Rideability	21
4) Recycled Material	24
B. Milling (Cold)	25
1) Method of Milling	25
2) Rate of Milling	26
3) Problems Associated with Milling	26
a. Poor Texture	26
b. Skid Resistance	35
c. Noise Pollution	37
4) Milling and Replacement with Open-Graded Asphalt Friction Courses	
C. Recycling	38

TABLE OF CONTENTS (Continued)

	<u>Page</u>
D. Raising of Manhole and Inlet Frames	41
1) Installation of Extension Frames	43
2) Installation of Extension Rings	49
E. Reflection Cracking	57
1) Background	57
2) Location and History of Test Section	59
3) Design of Test Sections	62
4) Sawing	64
a. Dry Cutting	64
b. Wet Cutting	64
5) Condition Surveys	66
a. Transverse Joint	66
b. Longitudinal Joints	69
c. Implementation	74
d. Joint Repair	84
SECTION VI	
RESULTS AND CONCLUSIONS	91
1. Milling	91
2. Recycling of Asphaltic Concrete	91
3. Resetting Manholes and Inlets	92
4. Reflection Cracking	92
SECTION VII	
FUTURE RESEARCH	
1. Saw-and-Seal Technique	93
2. Sealing Existing Joints Prior to Overlay	93
REFERENCES	94
APPENDIX A: Milling Specification	A-1
APPENDIX B: Guidelines for Pavement Recycling	B-1
APPENDIX C: Specifications for Cast Iron Extension Units	C-1
APPENDIX D: Guidelines for Raising Manhole and Inlet Heads and the Use of Extension Rings and Frames	D-1
APPENDIX E: Discussion of Joint Cleaning/Sealing Practices	E-1
APPENDIX F: Specification for Saw and Seal Procedure	F-1

LIST OF PHOTOS

<u>Photo No.</u>		<u>Page No.</u>
1.	Good Milling Texture	27
2.	Poor Milling Texture	27
3.	Band of Material Resulting from Missing Milling Teeth	29
4.	Striations Resulting from Use of Combination of New and Worn Milling Teeth	29
5.	Improper Cross Slope Due to Use of 2 Machines	30
6.	Poor Workmanship at Manhole	30
7.	Depression After Raising and Lowering of Cutting Drum	31
8.	Result of Loose Sensor Wand	31
9.	Weaving of Milling Machine	33
10.	Converging Striations	33
11.	Milling with New Drum - New Teeth	34
12.	Poor Quality Milling Representative of the Route 1 Project	34
13.	Stripping of Route 1 Repaired Area	36
14.	Potholing of Route 1 Repaired Area	36
15.	Pavement Condition on Route 1 Project Prior to Overlay	39
16.	Appearance of Route 1 Project after 10 Years Service	39
17.	Applying Bedding Compound	45
18.	Finished Bed	45
19.	Drilling to "Dimple" Old Inlet Frame	46
20.	Bolting of Inlet Extension Frame to Old "Head"	46
21.	Opening Between Grate and Frame	47
22.	Brazed Stop to Prevent Grate from Receding	47
23.	Inspection of In-Service Inlet Extension Frame	48
24.	Spalled Manhole Frames - Route 93 Project	51
25.	Corroded Sanitary Sewer Manhole Frame	51
26.	Wire Brush Cleaning of Extension Ring	54
27.	Degreasing the Castings	54
28.	Mixing Epoxy Bedding and Bonding Compound	55
29.	Applying Epoxy to Seat and Upper Surface of Manhole Casting	55
30.	Types of Reflection Cracking	58
31.	Reflection Cracking in Wheelpaths: As-Constructed Appearance of Overlay	61
32.	Reflection Cracking in Wheelpaths: Appearance of Overlay after 8 Years Service	61
33.	Example of Jagged Edge Due to Excavating	65
34.	Jagged Edge Cut Back Over Concrete on Route 10	65
35.	Typical Appearance of Route 22 after 7 Years Service	67
36.	Typical Reflection Cracking in Control Section	67
37.	Cracking of Repaired Slab	68
38.	Core Over Crack Repair	68
39.	Corner Crack	68
40.	Longitudinal Saw and Seal Edge Joint in Test Section	70
41.	Edge Crack Formation in Control Section	70

42.	Edge Crack Formation in Control Section	70
43.	Appearance of Longitudinal Joint on Route 22 after 7 Years Service	71
44.	Appearance of Longitudinal Joint in Previous Overlay	71
45.	Cold Joint in Test Section	72
46.	Cold Joint and Reflection Crack in Control Section	72
47.	Crack Propagation	73
48.	Crack Propagation	73
49.	Early Reflection Cracking	75
50.	Unaligned Joints on Route 40 & 322 Project	75
51.	Random Crack Saw	77
52.	Underpouring of Joint Sealant on Route 40 & 322 Project	78
53.	Overpouring on Route 40 & 322 Project	78
54.	Improperly Referenced Saw Cut, Skewed to Left	81
55.	Improperly Referenced Saw Cut, Skewed to Right	81
56.	Core Taken over Sawn Joint and Reflected Crack	82
57.	Closeup of Core Showing Sealer Attached	82
58.	Overview of Improperly Referenced Longitudinal Joint	83
59.	Closeup of Improperly Referenced Longitudinal Joint	83
60.	Reflection Cracking in I-80 Control Section	85
61.	Reflection Cracking in I-80 Control Section	85
62.	Longitudinal and Transverse Reflection Cracking after 7 Years Service	87
63.	Reflection Cracking at Ends of Concrete "Repair"	87
64.	Appearance of Overlay Surface	89
65.	Appearance of Underlying Concrete Joint	89
66.	Partial Decay of Concrete	90

LIST OF FIGURES

<u>Figure No.</u>		<u>Page No.</u>
1.	Cross Section of Extension Units	15
2.	Original Design of Cast Iron Extension Frame for Existing Inlet (Plan View)	42
3.	Improved Extension Frame Design (Typical)	44
4.	Design of Spacers for Worn Manhole Heads	52
5.	Improperly Fitted Manhole Covers	56
6.	Typical Sections for Route 22 Test Project	60
7.	Alternative Saw and Seal Treatments	63

PREFACE

Research by demonstration in the field can be a long, drawn-out process. First, a review of candidate projects must be made. Then a field survey must be made to determine which experimental treatments can be applied to a particular candidate project. Since new ideas are often treated with skepticism, usually no more than one experimental treatment is approved per project. Hence, multiple projects often must be considered. Appropriate specifications must then be written and construction details and plans drawn prior to the usual process of phase reviews, advertising, bidding, and award of contracts. Only then can the necessary construction and performance evaluations be performed.

This research study was carried out via the field demonstration route and was no exception to the above rule. Because of the many problems requiring solution and the number of candidate solutions to be tested, the research extended from 1975 to 1985.

One of the consequences of the long duration of this study is that at the time of the writing of this final report, some of the earlier solutions addressed in the research can be viewed as merely stepping stones to the present state-of-the-art, and hence are treated accordingly in the text. An example of this is the use of hot milling for pavement removal/restoration. New Jersey was the first state to use a commercial-size combination heater/milling head for pavement removal. With the advent of recycling, the hot milling technique gave way to the cold milling procedure, which yields a product more amenable to recycling. The hot milling phase of this investigation has thus been included in this report primarily for historical purposes.

Another consideration which weighed heavily in the preparation of this report is the fact that most of the solutions developed in this research are now

standard practice in our state, having been put into practice through the use of various implementation packages (i.e., specifications, design guides, construction operations bulletins, standard construction details, etc.) prepared during the course of the work. Given this fact then, the writer has kept the discussion of certain of these implemented techniques to the minimum needed for the reader to understand what was done and what was achieved in fairly summary fashion. When an implementation document is available describing in detail the findings of the work, the reader will be referred to those materials, which are appended to this report. An example of this is the use of extension units for resetting manholes and inlets. Appendix E of this report is a design guide which outlines in considerable detail the nature of current resetting practices, problems which can be encountered, and solutions thereto.

IMPLEMENTATION STATEMENT

The solutions developed in meeting the specific aims of this research project are in the main now standard practice in the State of New Jersey.

Some of the benefits of this research can be directly quantified in terms of a resultant cost savings. One such example is the use of extension units to raise manholes and inlets. Since the inception of the improved technology for using extension rings and frames for bringing heads to grade, over 15,000 units have been placed in New Jersey. Construction cost savings averaging in excess of \$250,000 per year have been realized, the bulk of which has accrued from the use of extension frames on gutter inlets. Some less tangible and more difficult to estimate, but nonetheless real savings associated with this technology are reduced driver delay time, driver discomfort, tort claims, and increased safety.

The use of milling to preserve overhead clearance and curb reveal, improve drainage and provide feedstock for recycling also qualifies as an intangible. Milling, however, was the precursor to both the hot and cold recycling of asphalt pavement. Without milling, only projects of large magnitude would be amenable to recycling, i.e., full depth bituminous pavement ripped up, crushed, screened, etc. Milling permits even the smallest quantities of asphalt pavement to be recycled in either state or commercial work. Milling/recycling not only permits the conservation of material and energy, but preserves the life of dwindling landfills.

The savings resulting from the use of recycled asphalt pavement (RAP) is also difficult to quantify. Since New Jersey's first demonstration project in 1973 (27,000 tons of RAP), the use of RAP on Department projects has grown to an estimated 500,000 tons in 1985. Since New Jersey now permits the addition of RAP up to 50%, the saving will be variable. The percentage of RAP used, the

type of mix, asphalt content, distance from aggregate source, etc. all enter into the potential savings. There is no question, however, that the savings can be significant. On a recent large tonnage project (Route I-78, 5E), there was a bid price differential of more than \$6 per ton between producers who intended to use recycled material and those whose bid was predicated on use of virgin material.

The benefits of other solutions developed in this investigation will only be quantified with time, e.g., the saw-and-seal system for the prevention of reflection cracking. The original test section has been maintenance-free for an eight-year period. How long this procedure will extend the useful life of the pavement will have to wait for a future determination. It is anticipated that the useful life will be extended 25% to 50%. (An economic analysis of the "saw and seal" procedure indicated that a 15% increase in pavement life would justify the extra expense.)

Implementation of the saw-and-seal system on two subsequent projects affected two other savings. The first of these was to reduce the quantity of joint sealing in the underlying concrete pavement in preparation for the initial overlay from 91,000 L.F. to 15,000 L.F. and 195,000 L.F. to 25,000 L.F., for savings of \$79,440 and \$119,000 respectively. The second saving permitted by the use of the saw-and-seal system was to reduce the thickness of the overlay from the usual 3" thickness to 2".

In finality it can be stated that the savings affected by the implementation of any one of the solutions in one year's time has more than paid the cost of this ten-year investigation.

SECTION 1

INTRODUCTION

It is axiomatic that, in order to be successful, a research project must fill a need. With this in mind, the New Jersey Department of Transportation's Division of Research and Demonstration annually solicits problem statements from various operating units within the Department of Transportation. In 1973, those responses indicated that the most pressing problem of statewide concern and probable national significance was "What can be done to overlaid pavements once the original overlay has failed?" This resulted in a research proposal for a study entitled "Second Generation Overlays".

Resurfacing and rehabilitation presents many problems not normally encountered in new construction such as interruption of traffic flow, traffic control, added safety protection for both the workers and motorists, restricted working hours, and loss of service to the motorist and the commercial community.

The scope of rehabilitative work is quite broad and may entail one or more practices such as lane additions, geometric safety improvements, blow-up and joint repairs, bridge deck repairs, median barrier installation, the correction of slippery pavements, or the removal, repair or overlayment of deteriorated or distressed pavements and shoulders. It was the latter type of project which was causing increased concern to design and maintenance forces.

Aside from the repairs necessary to restore a smooth riding pavement is the problem of resetting highway hardware. The common and seemingly simple practice of resurfacing a roadway makes the raising of manholes, inlets and utility frames mandatory if riding quality is not to be sacrificed. The practice of resetting heads, besides being costly, time consuming, and disruptive of traffic

flow, is also an annoyance to the motorist, as well as the general public due to, e.g., long-term ramped manholes, ponded water at inlets.

The aforementioned problems are being exacerbated by increasing traffic volumes and heavy axle loads which are decreasing the service life of urban streets, country roads, state and interstate highways at an alarming rate. In order to effectively aid the construction and design engineers meet the challenges posed by resurfacing/rehabilitation projects, Research will have to be more creative in developing the necessary solutions.

SECTION II

BACKGROUND AND SCOPE OF WORK

Up until the early 1950s, most state highways in New Jersey were constructed of portland cement concrete. The rehabilitation of these older roads, most of which have been overlaid one or more times with bituminous concrete, was problematic and hence a chief concern of the Department's Maintenance Unit. Therefore, for the purpose of this investigation, it was assumed that the pavement to be rehabilitated or resurfaced was generally structurally adequate and that riding quality and/or safety were the primary factors that dictated the pavement be scheduled for resurfacing.

One of the greatest problems associated with pavement resurfacing is the variability of the condition of distress existing in any given mile of roadway under consideration. A detailed condition survey may indicate any one or more of the following: channeling or rutting, corrugating, raveling, stripping, potholing, bleeding, longitudinal and transverse cracking, reflection joints, and cracks and slippery pavement.

All too often an "overlay" appears as the panacea to cure all these ills. A thin lift in many cases is purely cosmetic and offers little more than temporary relief. On the other hand, a thick lift on certain types of distress can be ineffective and wasteful of materials. Furthermore, repeated overlays reduce the vertical clearance of overhead structures, diminish curb reveal, produce undesirable cross slopes, and create drainage problems.

Many agencies frequently view maintenance only as a necessary evil and as a result, there is a sparsity of engineering supervision in the field. This lack of on-site technical personnel, in conjunction with the need to perform the maximum amount of work with the limited amount of dollars available, often

results in resurfacing yielding short service life and requiring premature maintenance. Reflection cracking has been the subject of many studies over the past fifty years and the problem still remains basically unsolved. As an adjunct to this investigation, an effort was made to provide an answer to the problem.

Aside from the technical solution to the aforementioned problems, the rapidly rising cost in labor and materials, the high cost of traffic control, the environmental restrictions and problems of waste disposal are considered.

SECTION III

OBJECTIVE AND SPECIFIC AIMS

The object of this study is to develop the methodology for the resurfacing of previously overlaid portland cement (composite pavements) and bituminous concrete pavements with the following specific aims:

1. To develop a method for the restoration of pavement riding quality without sacrificing overhead clearance;
2. To develop a method for restoring skid resistance without loss of curb reveal, or the introduction of undesirable cross-slope or drainage problems;
3. To determine what viable practice other than overlays may be employed to correct condition of distress such as rutting, corrugation, raveling and flushing;
4. To solve or facilitate the problem of raising of the manholes, inlet and utility vault frames in preparation of an overlay; and
5. To develop a procedure for the elimination or reduction of reflection cracking.

SECTION IV

RESEARCH METHODOLOGY

Removal of the existing bituminous concrete surface course appeared to be the common denominator for the solution of items one, two and three of the specific aims. Four procedures were considered as methods of solution:

1. Removal by milling
2. Removal by planing or scarification and repavement
3. Partial pavement removal and replacement with a dense graded mix
4. Partial pavement removal and replacement with an open-graded asphalt friction course mix

A. Removal by Milling

Removal by milling has been used in Germany and England for over a decade. The machine typically consists of an infrared heating unit and a milling head*. The milling head has a 12'-4" rotary drum containing hardened steel teeth for milling off the partially softened bituminous pavement to a maximum depth of 4". The milled material is windrowed for pick-up with a front end loader and placed in a truck for disposal or reuse at another location. The forward speed of operation depends on the depth of cut, type of aggregate, and ambient temperature. The rate of pavement removal was quoted by the manufacturer as 5,000 to 10,000 square yards per day at a nominal 1-1/2" milling depth. The milling machine, therefore, was selected as a unit for partial or full depth removal on composite pavements or full depth bituminous sections. Two American-made cold planing units, which were then available with milling head widths of 31" and 60", were investigated but rejected as being too small for state

*Prior to 1974, this machine was known as a planer. The term "milling" was instituted by the author in 1974.

work. Since the inception of this research investigation, American equipment manufacturers have, of course, developed and marketed a myriad of milling machines of all sizes.

B. Planing, Scarification, and Repavement

These processes have been employed in several states and municipalities, using one of several similar, yet distinct pieces of equipment: the helio-planer, heater planer, jumbo heater, asphalt scarifier, or repaver.

The helio-planer unit consists of an infrared heater to soften the asphalt pavement, a double set of carbide tipped teeth for scarifying and a self-sharpening plow for windrowing the loosened material for pickup and possible use at another location. The heater planer operates in a similar manner, except that planer blades are used for scarifying and windrowing the material. Both are used for the removal of pavement distortions to depths of 3/8" to 3/4", 8' wide.

The Jumbo Heater and the Asphalt-Scarifier are adapted from their forementioned counterparts differing slightly in construction and end result. Instead of plows for removal of the asphaltic concrete, the scarified material passes through a leveler or an oscillating screed (depending on the piece of equipment) to level the material and provide the initial compaction. In some cases, an emulsion, rejuvenating agent, or sand may be added prior to rolling, depending on the asphalt content of the pavement.

The repaver, a multiple-step machine, has dual heaters with a scarifier behind each heater. The scarifiers cut through the heated surface at two inch intervals. The first scarifier removes approximately 60 percent of the heated pavement. Combined with the secondary heating and scarifying units, up to 80

percent of the old pavement can be removed. Left and right-hand mixing screws gather the material into a windrow for the oncoming leveling screws that prepare the recycled asphalt mix for the screed. While all the heating and scarification is going on, a new hot mix is being dumped into a hopper on the front of the machine. The new hot mix is then conveyed over the heater and scarifying equipment to the second section of the repaver which is similar to a standard paver. The new hot mix is deposited on the recycled material at a rate of 75 pounds per square yard and the two mixes are "welded" together under the compaction of a roller.

C. Partial Pavement Removal and Replacement with a Dense Graded Mix

This procedure can be used as an "inlay" method when correcting conditions of distress without incurring a loss in the design strength of bituminous sections. A prime example would be removing the rutting in the outside lane of a multi-lane highway or corrugations at a traffic signal. This method of treating selected areas would permit restoration of a smooth riding surface and provide better drainage at a relatively low cost.

D. Pavement Removal and Replacement with an Open Graded Asphalt Friction Course

This procedure would be adaptable where loss in skid resistance, or other conditions of distress may be prevalent on composite pavements. An open graded mix with its inherent high void content will provide excellent skid resistance but not add to the structural integrity. At the outset of this study, however, there were some concerns as to whether the useful life of open-graded mix might be reduced if placed in certain service environments. For example, it was thought that use of an open-graded mix on a heavily rutted pavement might

permit water to collect in the ruts, resulting in deterioration by freezing or stripping.

E. Discussion of Equipment Selection

Prior to this investigation, the Wirtgen milling machine successfully demonstrated its capabilities on a 1.7 mile section of U.S. Route 1 in South Brunswick, New Jersey. In this 1974 demonstration, the machine removed 3/4" rutting in the wheelpaths and as much as 1-1/2" of shoved material in the outside lane in stopping areas. The milled surface carried traffic for a period of five weeks before overlayment without any driver discomfort. Riding quality was improved as corroborated by measurements made on the section with a Mays Ride Meter.

The helio-planer, which is also capable of removing material, would have to make two passes in order to achieve the desired 12' width and two more to make the required depth. Another concern was whether the blades, which gather the mix loosened by the carbide scarifiers, would remove the apparent striations. If not, then it would be doubtful if the lane could be opened to traffic in the scarified condition for any length of time without an overlay.

The heater-planer, which was observed on a job in Harrisburg, Pa., also would require a great many passes in order to achieve the required planed width and depth. It also had the drawback of temporarily defoliating the trees along the route.

The repaver was also discounted because of the high number of passes expected to be necessary, plus the fact that its ability to handle a mix with 1-1/2" stone was unknown. Furthermore, the units were tied up with other contracts and needed too long a lead time to fit in with our schedule.

Based on these facts then, the hot milling machine was selected for use in this study.

F. Manhole, Inlet and Utility Frames

In preparing for a resurfacing, manhole, inlet and utility frames are adjusted (reset) to match the new elevation. In some areas, these heads* are as numerous as 120 units per mile.

Using the standard procedure of raising heads by brick and mortar is a slow process. One crew typically can raise only about two units per day in a portland cement concrete pavement. In a bituminous pavement, a single crew may raise 3 to 4 units per day. Because of these low production rates, motorists may be inconvenienced for a considerable period (up to 6 to 12 weeks). Another drawback of the brick and mortar method is that the roadway is occasionally opened to traffic before sufficient strengths and/or bond is developed in the mortar. This results in premature failure of the resetting and a tilting of the head.

To overcome these resetting problems, the use of cast iron extension units was investigated. These extension units are basically a replica of the top section of a casting (Figure 1), with the height of the unit (rise) being selected to coincide with the design thickness of the resurfacing layer(s) so as to bring the extension unit to a position flush with the new roadway surface. The procedure initially envisioned for this investigation was to place a bedding compound on the seat of the frame and bolt the extension units to it via set screws.

*"Heads" is the common shorthand expression for highway manhole and inlet hardware consisting of cast iron frames, curb pieces, covers and/or grates.

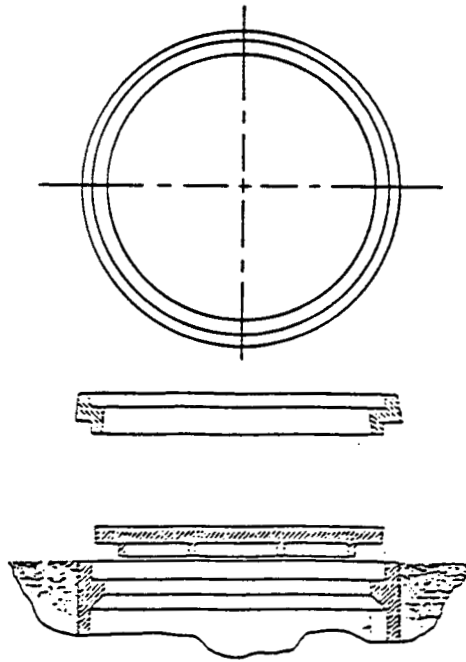

EXTENSION RING 1a

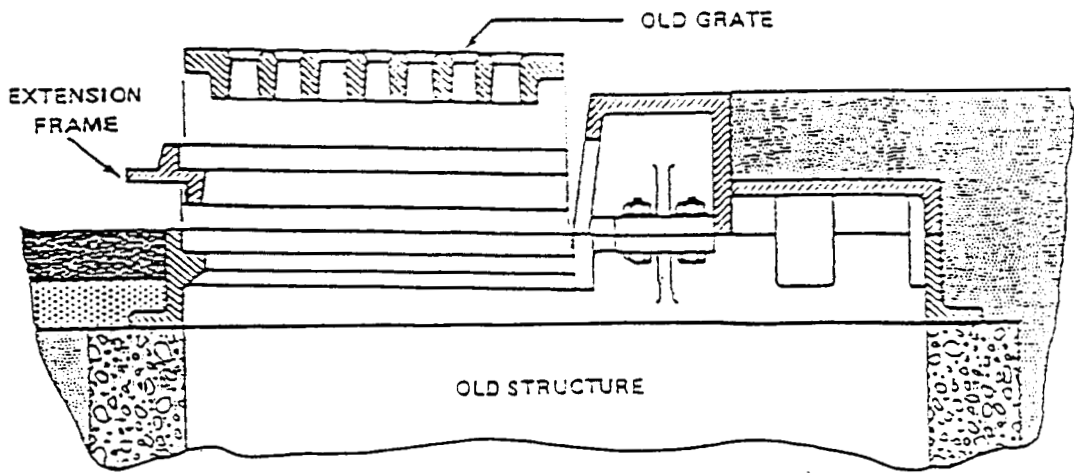

EXTENSION FRAME 1b

FIGURE 1:
CROSS SECTION OF EXTENSION UNITS

G. Reflection Cracking

Reflection cracks are perhaps the most problematic type of crack in bituminous overlay pavements, particularly those that propagate through the resurfacing layer(s) placed over portland cement concrete pavements.

A review of the literature indicates that considerable emphasis has been placed on preventing reflection cracks through the use of increased overlay thickness. For example, at the 1932 HRB annual meeting, Gray and Martin⁽¹⁾ reported that reflection cracking could be controlled with a three inch penetration macadam or with a 3" plant mix surfacing over badly cracked portland cement concrete surfaces. In 1973, Hensley⁽²⁾ reported similar success in retarding reflection cracking by the use of three inches of open-graded base course covered with 2-1/2" to 3" of dense graded asphalt concrete. In 1975, the Asphalt Institute issued construction leaflet No. 16 which recommended a 7" pavement structure, featuring a 3-1/2" crack relief layer of coarse open-graded hot mix, a 2" dense graded leveling course and a 1-1/2" surface course.

The use of increased overlay thickness as a method of reflection crack control, even if successful, obviously would run counter to another aim of this study, namely, to preserve overhead clearance and curb reveal. Many other methods such as placing welded wire reinforcement in the bituminous overlay, bond breakers, the use of a slurry seal before resurfacing; a stress absorbing membrane interlayer (SAMI); synthetic and fiber glass mats for full lane width or as strip material over specific cracks; rejuvenating agents and asphalt mixtures with elastomeric, rubber and fiber additions or softer asphalts, have been tried with varying degrees of success.

A method not widely used at the inception of this study involves the use of "controlled" cracks. This procedure, termed a "weakened plane system" by the author, entails sawing joints in the asphalt concrete overlay over the underlying

portland cement concrete transverse-joints and sealing the sawn joint with a bituminous sealer. The basic idea here is that reflection cracking cannot be prevented; therefore, make provisions for it to occur as a controlled, sealed "crack" which will prevent water damage occurring to the underlying structure and will need little or no maintenance.

SECTION V

DETAILS OF INVESTIGATION

Due to the number of experimental features to be conducted in this research project, six locations were selected for the various phases which will be reported, in the main, chronologically.

A. Milling (Hot)

With the advent of major recycling projects, hot milling dropped from vogue due to the inability to stockpile the hot milled material. The following phase of the report, therefore, has been reported for historical purposes.

The first contractual use of a milling machine in New Jersey was on the U.S. 130, Section 7J project. The length of this project was 3.53 miles from the vicinity of the Airport Circle to Union Avenue in the Township of Pennsauken, Camden County. The milling was accomplished with a Wirtgen machine.

The roadway consisted of six lanes of pavement divided by a concrete median barrier. The width of each (north and southbound) pavement was 31 feet and variable. The pavement section consisted of 3" of bituminous overlay on 10 inches of reinforced portland cement concrete.

The bituminous overlay had become badly rutted in the wheelpaths. Straightedge measurements showed rutting and shoved materials to exceed a 2" depth in several areas. Since the customary method of correcting rutting -- installing a leveling course and a new riding surface -- would have encroached on the lower sloping face of the concrete median barrier, this project became a candidate for milling.

Milling would not only preclude encroachment on the barrier curb, but would remove the rutting, thereby negating the need of a leveling course and

eliminating the possibility of differential compaction (and hence, the early re-emergence of rutting) in the new overlay. This essentially would restore the new pavement to the original elevation while preserving the reveal on both the curb and barrier.

Because of the heavy volume of traffic (AADT 37,600), the project was scheduled as a night operation from 9:00 P.M. to 5:00 A.M. Milling started on October 6, 1975 in the outside lane of the northbound roadway. During the course of construction, the temperature of the windrowed material taken at distances from 5' to 20' behind the milling machine varied from 140° to 150°.

Due to the presence of highway hardware, the milling was periodically interrupted, leaving an unmilled transverse bump at the manholes, water valves and inlets. Because the drum bearing housing extended out from the machine, approximately 5" to 6" of the pavement was left unmilled at the curb and the concrete median barrier. The unmilled areas and the transverse bumps were removed with a three wheeled milling machine having a 1' cutting head.

The windrowed material was picked up and placed in trucks by a front end loader and hauled to a location some 20 to 30 minutes away for later use by the Department's Maintenance forces on a shoulder rehabilitation project on Route 73.

1) Rate and Cost of Milling

The rate of milling was effected by various construction conditions, traffic requirements and obstructions such as manholes, inlets and utility frames which were mainly in the outside lane. The production rates achieved are shown in Table I.

TABLE 1

Milling Rates for Route 130, Section 7J

<u>R-3 (outside lane)</u>			
5 day average	4715 sq. yds.	521 sq. yds./hr.	380 L.F./hr.
<u>R-2 (center lane)</u>			
3 day average	7509 sq. yds.	777 sq. yds./hr.	566 L.F./hr.
<u>R-1 (inside lane)</u>			
3 day average	7372 sq. yds.	804 sq. yds /hr.	586 L.F./hr.

The cost of milling was \$1.03 sq.yd. A total of 109,399 sq. yds. of milling produced 6200 tons of milled material which was hauled to the Route 73 shoulder rehabilitation project site for \$23,400 or \$3.77 per ton.

According to the plans, the design engineers estimated that an average of 1" of material had to be milled off in order to bring the finished surface to the planned grade. Cross sections taken before and after milling at ten stations on the project showed the change in elevations ranged from 1/8" (bottom of rut) to 2-3/4". The mathematical differences in 560 before/after elevation measurements indicated that the average depth of material removed was 1-3/16 inches.

The texture of the milled pavement was generally good. Due to tilting of the underlying concrete slabs, the machine milled to the base concrete in several areas. After being exposed to snow plowing and adverse winter conditions some of the thinly feathered areas adjacent to the exposed concrete scaled off.

With the rutting removed, the drainage was improved and the possibility of hydroplaning averted. Removal of the shoved material also eliminated the uncomfortable "dipping" previously experienced by vehicles which crossed the Route 130 intersections.

2) Skid Resistance of Milled Surface

To evaluate the possibility of milling being used as a method to increase or restore skid resistance to a pavement, skid numbers were taken after the milling operation and after 4 months of exposure to traffic and weathering.

Prior to the milling operation, skid measurements were made on all three lanes of the project in both directions. Due to increased traffic, later skid tests were confined to the outside lane. The milled surface initially produced a significant increase in measured skid resistance (13-14 units or approximately 40%). This measured improvement degraded under traffic so that after four months, the skid resistance of the milled surface was only slightly better than the pavement before milling. It was apparent from visual observation that smoothing of the milled texture had taken place. Had the milling been started during the summer months, the loss in skid resistance might have been greater and/or the change in skid resistance might have occurred in a briefer period of time. (Various factors that influence the skid resistance of a milled surface will be discussed later in the text, however, high ambient temperature appears to have the greatest effect.)

3) Rideability

The basic reason for resurfacing work is to provide a safe, smooth ride to the motorist at a reasonable cost. As discussed previously this roadway was plagued with severe rutting, shoving, and corrugating, particularly at traffic signals. In order to alleviate these problems and not encroach on the median barrier, the combination of milling and single (1½") lift overlay was selected as the most practical strategy for improving the Route 130 pavement.

At the time this project was constructed, New Jersey Department of Transportation specifications contained smoothness acceptance provisions⁽³⁾,

however, those provisions applied only to new construction, not rehabilitations. While the New Jersey Department of Transportation has adopted smoothness acceptance provisions for rehabilitation projects, those provisions do not generally apply to single lift paving such as used on the Route 130 project because of the recognized difficulty in achieving a smooth ride with single lift paving.

For the informational purpose of making a general assessment of the rideability of the Route 130 project before and after paving, roughness measurements were made with the New Jersey Mays Ride Meter. The values obtained were as follows:

TABLE 2

Mays Ridemeter Readings (40 MPH) for
Route 130, Section 7J, MP 30.0 to 33.9 SB

	R1	<u>Average and (Range)</u> R2	R3	<u>Grand Average</u>
Before	89 (76-135)	115 (70-180)	148 (102-221)	117
After	54 (45-60)	65 (56-76)	78 (59-121)	66

Croteau's⁽³⁾ work has resulted in the following rating system for evaluating the output of the New Jersey model of the Mays Ride Meter:

TABLE 3

Rideability Equivalents of New Jersey Mays Readings (40 MPH)

<u>Mays Reading</u>	<u>Rideability Rating</u>
Less than 33" per mile	Good
33" - 50"	Fair
51" - 70"	Poor
71" or more	Very Poor

Comparing the average Mays ride meter reading for the Route 130 project (66 inches/mile) to the above criteria indicates that the rideability of the pavement would be categorized as "Poor". As indicated in Table 2, the roughness of the resurfacing increased from the inside lane to the outside lane. The primary reason for this was the presence of inlets, manholes, and/or utility frames in the outer lanes. By way of reference, a sample of some 20 two-course resurfacing jobs constructed contemporaneously with the Route 130 project displayed an average Mays ride meter reading of 37 inches/mile.

While the rideability of the Route 130 project did not compare favorably to that of other projects, the nearly 50% reduction in roughness achieved by the resurfacing (66 vs. 117 inches/mile) was undoubtedly a welcome change for motorists using that route.

4) Recycled Material

The hot milled material delivered to the maintenance forces was used to construct the north and southbound inside shoulders on Route 73 between the Marlton Circle (Route 70) and Voorhees in Camden County, New Jersey.

The shoulders were constructed as follows: During the day, maintenance forces excavated a trench 4' wide and 6" deep. At night, the milled material was delivered by the contractor and dumped on the inner lane of the concrete pavement. The piled material was then bladed by a grader into the excavation.

The as-delivered temperature of the material varied from 124^o to 132^oF. However, since the material arrived faster than it was placed, this delay in placement caused the temperature to drop considerably in the 59^oF ambient night air. The cooled (90^oF to 108^oF) material was initially compacted with a two-wheel tandem roller. Later, grader wheels were used for compaction. Successive blading and compaction left a fairly even surface, approximately 1" below the pavement grade. This was surfaced with a thin lift of bituminous concrete the following spring.

Cores taken of the recycled milled material in the north and southbound shoulders averaged 9% and 10.2% air voids respectively.

B. Milling (Cold)

Cold milling was not considered at the onset of this investigation since the available equipment was not considered adequate for large scale production. However, with the introduction of the Wirtgen milling machine in New Jersey in 1974, American Manufacturers were spurred into producing the cold milling or planing machines of today.

The cold milling project took place on U.S. 1 between the Route I-130 circle and I-295 during the summer and fall of 1978. The pavement on this project generally consisted of a 19 year old, 3" bituminous overlay over a 9" jointed portland cement concrete pavement. Approximately 18 miles of the southbound and 7 miles of the northbound outside lanes were milled. It was estimated that 15,000 tons of milled material would be generated in the process.

1) Method of Milling

The depth of milling on the outside lanes differed due to the types of distress. Both of the outside lanes were badly rutted (Average Depth: 9/16") and had corrugations in the stopping areas at traffic signals.

The northbound lane also displayed severe island cracking at the inner wheelpath and edge cracking at the shoulder line. The crack at the inner wheelpath occurred over the underlying concrete slabs, due to lane widening.

The plans called for milling off 1½" of the surface of this lane, 12' 4" wide, starting a few inches from the traffic line to a point 8" into the shoulder. This effectively removed all forms of distress in this lane.

The southbound lane was milled an average 5/8" deep, 12' 4" wide starting from the bottom of the rut in the inner wheelpath to cutting daylight 2' out in the shoulder. At intersections and jughandles it was milled to a depth of 1½" for a distance of 500' before and through the intersection. This method of milling

was devised to alleviate the rutting by removing the shoved material from the skipline and the edgeline as well as the corrugations in the stopping areas. All the 1½" deep milled areas were filled with bituminous binder material as soon as possible after milling.

2) Rate of Milling

There will be no discourse on the rate of milling since this topic has been thoroughly researched by the FHWA for all types and sizes of planing and milling equipment under Demonstration Project No. 23.^(4,5) What will be discussed is problems of excessive rates of machine speed (see 2a below).

3) Problems Associated With Milling

By and large, cold milling is a good method for pavement removal, changing profile and grade control, maintaining and/or increasing curb reveal and overhead clearance. Many problems, however, can be associated with milling such as:

- a.) Poor texture
- b.) Loss in skid resistance
- c.) Noise Pollution

a. Poor Texture: The milled surface as exhibited in brochures from equipment manufacturers shows a nicely textured surface (Photo 1). In reality this is the exception rather than the rule. More often the surface is heavily striated as shown in Photo 2. There are several reasons why striations occur: the forward speed of the machine, the density of the material, the ambient temperature, and variations in the hardnesses of asphalt pavements.

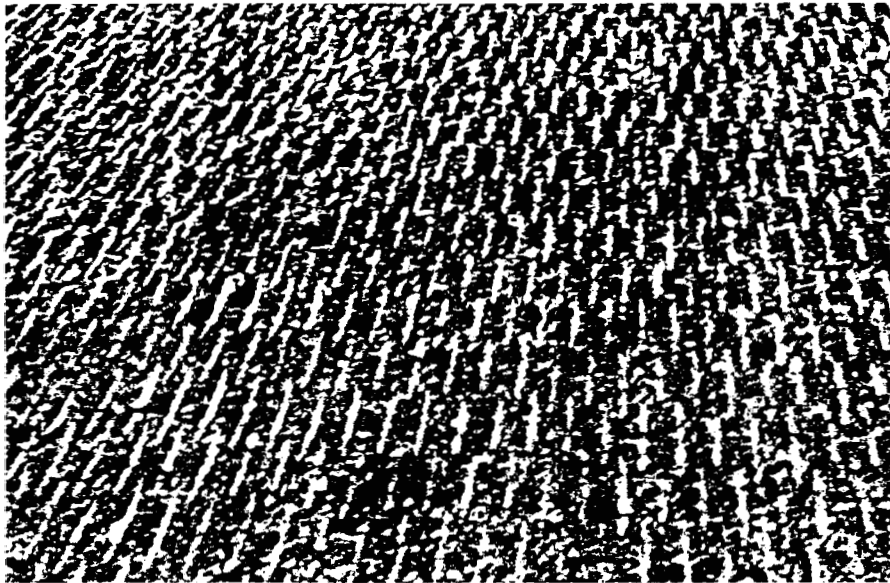

PHOTO 1
GOOD MILLING TEXTURE



PHOTO 2
POOR MILLING TEXTURE

Overly fast or slow machine speeds can cause striations. The rotation speed of the cutting drum is constant and the tip speed of the cutting teeth is approximately 1000 to 1100 feet/minute. When the forward speed of the machine exceeds 45-50 feet/minute, the tendency is to pull the teeth through the material causing striations. The same problem of striating can occur when the machine is too slow (10 feet/min. or less) or milling in an extremely fine mix with a high asphalt content. For example, at a slow forward speed and constant drum speed the milling machine acts as a saw, leaving a continuous striation, rather the desired textured surface. When the speed is slow and AC content is high, the bond between the asphalt cement and the aggregate is not broken, preventing the aggregate from being dislodged.

Another cause for striations is missing or misaligned cutting teeth. When a tooth falls out and is not replaced, an almost solid band of material will appear in the milled surface (Photo 3). If a new (longer) tooth is inserted, the striation is more pronounced (Photo 4). Consequently, when a tooth is replaced, it should be one comparable to the rest of the teeth on the drum. Problems with misaligned teeth usually result from field welding a post (tooth holder) on to the flights. Effort has been made by various manufacturers to alleviate this condition by either using bolt on holders or alignment pins and holes for the welded-on types.

Originally, it was planned that the milling would be accomplished in a single full width pass. However, the contractor used two machines to make the required 12'-4" width. If one of the units was down for repair the other would continue to mill. This constant surging of one machine past the milled surface of the other resulted in a poor cross slope. In some cases there would be a slight "V" (Photo 5) and in other cases an inverted "V". Other cases of shoddy workmanship occurred in the vicinity of manholes as shown in Photos 6 & 7.



PHOTO 3

BAND OF MATERIAL (CENTER OF PHOTO) RESULTING FROM MISSING MILLING TEETH

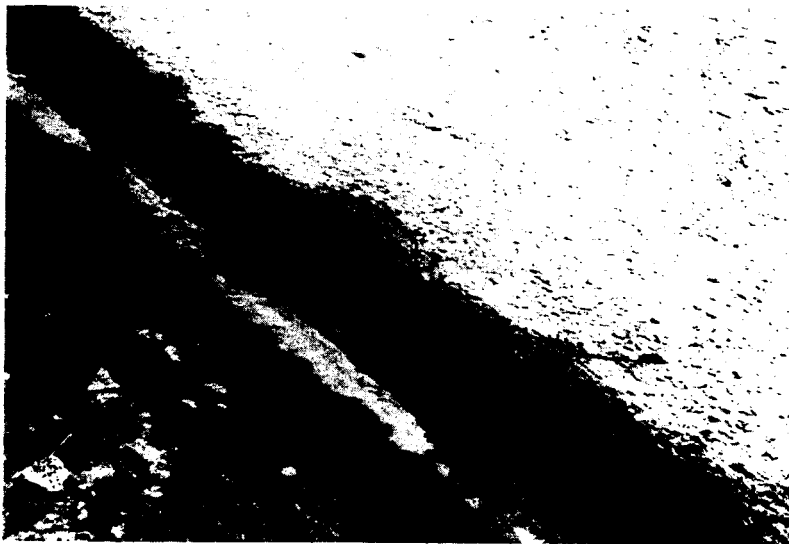

PHOTO 4

STRIATIONS RESULTING FROM USE OF COMBINATION OF NEW AND WORN MILLING TEETH



PHOTO 5
IMPROPER CROSS SLOPE DUE TO USE OF 2 MACHINES



PHOTO 6
POOR WORKMANSHIP AT MANHOLE

RESULT OF LOOSE SENSOR WAND

PHOTO 8

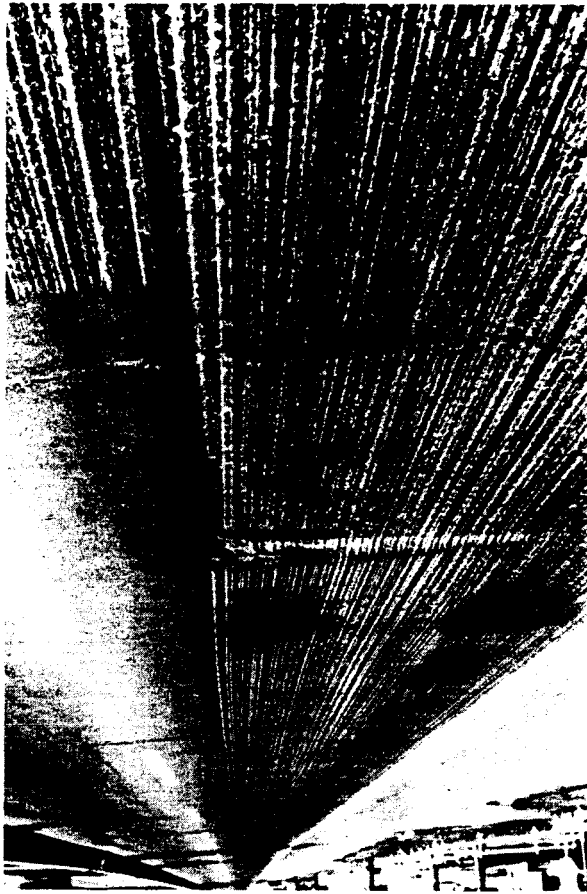

DEPRESSION AFTER RAISING AND LOWERING OF CUTTING DRUM

PHOTO 7

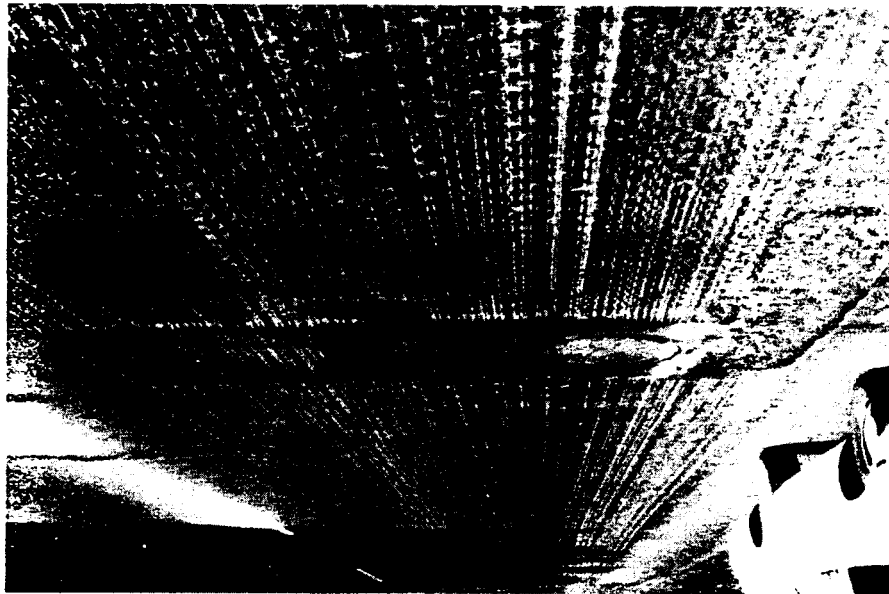

If the wand to the sensor loosens or a grade follower is stepped on, a condition as exhibited in Photo 8 will occur.

When an empty truck passes over the unmilled surface (Photo 7) or the depressed surface (Photo 8), dynamic jump is imparted to the vehicle which lands with a resounding crash. In Photo 8 the vertical face at the interface of the milled/unmilled surface ranged in height from 0 to 4" in a distance of 15'. This height differential and the depression conditions could adversely affect steering control. This condition could be extremely hazardous to motorcycles and small vehicles when executing a lane change.

As mentioned previously, on the southbound roadway the normal 5/8" milling depth was increased to 1 1/2" 500' before and through the intersection to remove corrugations in the stopping areas. The milling machine operator would swing the machine in 2' and mill the additional depth with no interruption in milling. The procedure was then reversed at the end of 500'. This weaving procedure, combined with the striated texture, caused a driving control problem with small cars. Photos 9 & 10 demonstrate how the texture is effected when the milling equipment is used improperly.

Reaction to the milled surface was swift -- a petition signed by 684 motorists was sent to the governor. There was lots of publicity-- all of it bad. Newspaper headlines and editorial captions were as follows:

"Your in the groove on Route 1."

"Hum-m-m dr-d-drum road r-r-rattles Route 1 r-r-riders."

One editorial suggested the person responsible be sent to Outer Mongolia.

The last 3/4 of a mile was milled with a new drum and all new teeth. The results may be seen in Photo 11. Photo 12 is more representative of what the project was like and is shown for comparison.

At the outset, Research advised the inspector and resident engineer that the milled surface would not meet the specifications; however, being an advisory



PHOTO 9
WEAVING OF MILLING MACHINE



PHOTO 10
CONVERGING STRIATIONS



PHOTO 11
MILLING WITH NEW DRUM - NEW TEETH



PHOTO 12
POOR QUALITY MILLING REPRESENTATIVE OF THE ROUTE 1 PROJECT

group, the advice went unheeded until the adverse publicity appeared.

The head of specifications wanted to sue for non-compliance and the author had gathered enough data to back his contention. To correct this condition, Research suggested the use of a heater-planer, which at a nominal figure (\$25,000) would have eliminated the problem by removing the striations. The Department instead chose to mill off an additional 5/8" and place a binder course the entire length of the southbound lane at an additional cost of \$126,000. This binder course, placed in late November and December, became a prime candidate for stripping and pot holing over the winter months (Photos 13 & 14). The problems heretofore cited would never have occurred had the contractor followed the specifications and the state inspector enforced them.

To prevent a repetition on future projects, provisions for a test strip to determine the correct operating conditions for the milling equipment for each particular pavement were incorporated into the specification. A copy of the specifications is included in Appendix A.

b. Skid Resistance: Skid testing was performed with a unit produced by the Davidson Laboratory of the Stevens Institute of Technology. These units conform to American Society for Testing and Materials specification E-274 and are checked for calibration each year at the Transportation Research Center at East Liberty Ohio.

The skid resistance after milling showed the average test value (SN_{40}) to be 48.9 on September 28, 1978. Five weeks later, November 9, the average skid number was 41.4., a reduction of 7.5 units. This is similar to the 10.5 average loss experienced in 1976 with the hot milled operation after four months of exposure to traffic. A third milling operation (cold), performed in late June, 1983, was tested for skid resistance, after nine (9) days of hot weather ranging



PHOTO 13
STRIPPING OF ROUTE 1 REPAIRED AREA



PHOTO 14
POTHOLING OF ROUTE 1 REPAIRED AREA

between 89°F to 93°F. The average skid numbers before and after the nine days of moderately hot weather were 49.0 and 30.0 units respectively. This was a 38.8% drop in skid resistance in an extremely short period. In contrast, a fourth project having comparable traffic volumes, showed no significant drop in skid resistance in a one year time frame.

Given these varying results and the many influencing variables (e.g., type and grade of asphalt, type of aggregate, degree of hardening of the asphalt, geographic location, traffic volumes, etc.), it is obviously a very difficult task to predict how long the increase in skid resistance might last. Based on the data, it is the writer's opinion that milling performed in the fall should give adequate skid resistance for approximately six months. On the other hand, during the hot summer months, the skid resistance resulting from milling may be short-lived.

c. Noise Pollution: Noise measurements were made with a portable hand sound level meter (A-scale) inside a state vehicle traveling at 55 mph. The sound level on the unmilled inner lane ranged from 70 to 72 decibels. Readings on the milled outer lane were 77 to 80 decibels, and when changing lanes from the inner to outer lane the readings were as high as 84 decibels. Since "each increase of 10 decibels means a tenfold increase in sound intensity or pressure and an approximate doubling of the noisiness to average human ears and nervous system,"⁽⁶⁾ it would appear that the noise level on this rough, milled surface was a source of annoyance to motorists.

4) Milling and Replacement with Open-Graded Asphalt Friction Courses

As noted earlier, at the outset of this study, there was some concern whether when certain distress conditions were present (e.g., rutting), that the use of milling or planing might be a prerequisite to the success of an open-graded

friction course. This was predicated on the possible stripping and/or delamination of the open-graded friction course due to entrapped water.

As it turns out, this concern was misplaced. That is, in a 1975 resurfacing of Route 1, an open-graded friction course was placed on a very heavily-rutted and shoved bituminous overlay (see Photo 15); in one case with no pretreatment of the existing surface and in the other, after construction of a "drag course" in the wheelpaths. Subsequent evaluations of these sections indicated that they gave equivalent "good" performance (see Photo 16). Since milling thus did not appear to be a necessary pretreatment, the use of open-graded friction course was not pursued further in this study. Rather the treatment of this topic was included in a separate Research project (NJDOT Study 7711), which study included in its objectives a comprehensive analysis of all types of skid resistant surfacing including open-graded mixes. Suffice it to say that the latter study has subsequently shown open-graded mixes to be a cost-effective technique for restoring skid resistance.

C. Recycling

When a hot milling operation is used, the milled material must be used as it is produced. Cold milling, on the other hand, produces a product that can be stockpiled and used in recycled asphalt pavement (RAP) mixes as needed. A full description of the recycling investigation has been previously reported under FHWA Demonstration Project No. 39⁽⁷⁾.

In order to avoid repetition, a summary is offered for familiarization. The report describes the design, testing and production of a bituminous concrete mixture using the "Minnesota Heat-Transfer Method" of recycling RAP through a conventional asphalt concrete plant. Using a 50/50 blend of RAP to virgin material approximately 14,000 tons of fine aggregate bituminous RAP was



PHOTO 15
PAVEMENT CONDITION ON ROUTE 1 PROJECT PRIOR TO OVERLAY



PHOTO 16
APPEARANCE OF ROUTE 1 PROJECT AFTER 10 YEARS SERVICE

converted to 27,000 tons of a coarse aggregate mix with no significant problems. The recycled material was placed on the outside and inside shoulders of the north and southbound roadways of Route 130 in 2" and 3" inch lifts for a distance of 28 miles. No transverse cracking occurred during the three-year evaluation (1978-80). A 1200' section of 1½" surface course was placed full width on the mainline concrete pavement. After two winters, only four joints reflected through the overlay. As a frame of reference an adjacent control section of equal length paved with the standard I-4 all-virgin mix reflected through at 27 joints. It appears that the recycled mix is at least as good, if not better, than the all-virgin material mixtures.

As a result of the calculated savings in energy (3.5 billion BTU, representing savings of 704 tons of asphalt cement and 12,753 tons of stone aggregate), plus a \$50,346 monetary saving, the New Jersey Department of Transportation accepted recycling as an alternate on paving contracts. Several other projects were placed with recycled mix produced in both batch and drum mixer plants.

Progress in recycling was rather slow due to the reluctance of producers to buy or convert equipment. In order to encourage recycling, the Department permitted the use of 10% RAP from any source to be used in base and binder courses (open system). Mixtures containing 20% to 50% RAP were limited to projects where the existing pavement is removed, recycled, and returned to the same project (closed system). The restriction of using the closed system was to assure that the RAP material would be of consistently good quality.

More recently (1985) the Department changed the specifications to permit the use of 20% RAP in the open system. Currently, on an evaluation basis, the Department has permitted the use of 10% RAP (open system) in the surface course on 25 overlay projects.

A set of guidelines for pavement recycling was prepared for the Division of Design and was distributed to municipal and county engineers for guidance in the preparation of Plans and Specifications; a copy of which is found in Appendix B.

D. Raising of Manhole and Inlet Frames

The use of extension units (see Figure 1) for bringing heads to the designed grade is not novel, having been in vogue two decades prior to this research study. However, because of performance problems (i.e., covers popping out, risers cracking or breaking loose), the use of extension units was discontinued in New Jersey except as an alternate for use on inlets in the shoulder area.

In hindsight, it appears that the problems historically encountered with manhole extension units (rings) were due primarily to use of worn hardware and/or improper installation techniques. For example, one major reason for rings cracking was undoubtedly localized overstressing of the cast iron due to improperly seated extension rings because of a worn seat on the manhole frame. Another mistake was spot welding the ring to the existing frame, which caused embrittlement of the iron in the vicinity of the weld, causing it to break loose. Finally, due to its irregular bottom surface, a worn cover placed on the flat (machined) seat of an extension ring becomes a prime candidate for being flipped out by passing vehicles.

Historically, the three-sided U-shaped extension frames used for raising inlets also left much to be desired (see Figure 2). First, the three-sided unit is subject to distortion during the cooling process after casting. Secondly, the method to hold it in place was very poor. The unit had a 3" wide by 3/4" thick flange running around the perimeter of the casting and depended on the overlay (1-1/4") to hold it in place. A passing vehicle riding over the grate would cause rocking of the extension frame with the subsequent cracking of the thin overlay over the edge of the flange. The result was a loose, noisy inlet.

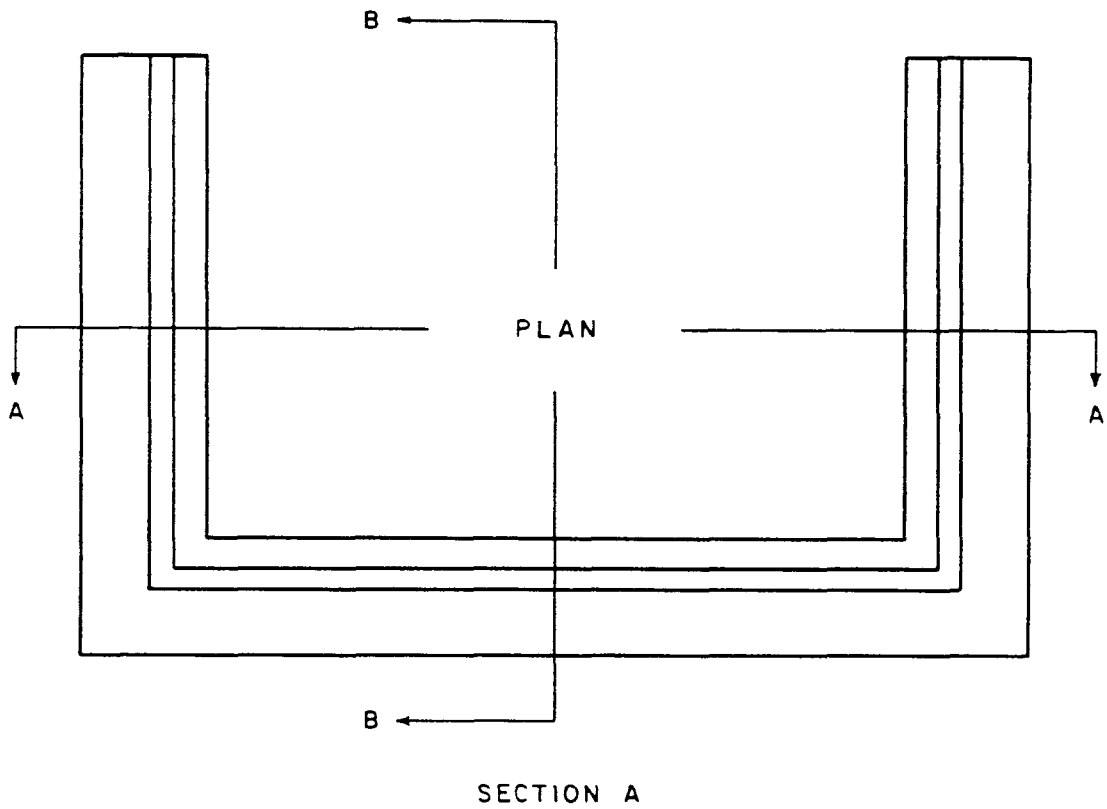

FIGURE 2 :
ORIGINAL DESIGN OF CAST IRON
EXTENSION FRAME FOR EXISTING INLET
(PLAN VIEW)

To overcome the aforementioned problems, a new 4-sided frame (Figure 3) was developed. Provisions were made for bolting the extension units to their respective frame castings. To preclude any localized overstressing of the cast iron, a light coat of a bedding compound was applied to the old frame to insure uniform seating.

1) Installation of Extension Frames

The first experimental field test installation of the new 4-sided extension frame was made on the U.S. 130, Sec. 7J project. Eight units were ordered from a midwest producer for the test. Due to a trucking strike, delivery was delayed for several weeks. Paving had progressed to the point where only four units were eligible for installation on July 14, 1976. There were no specifications for the bedding compound and the contractor applied a Pecora Asbestos Furnace Cement (Photos 17 & 18). Holes were dimpled into the inlet frames and the extension units bolted in place (Photos 19 & 20). It took 55 minutes to make the installation. Most of this time was taken up in the drilling of the dimples in the old frame.

The original design called for the grate to butt up against the curb piece. However, on this installation, due to the way the curb piece was placed, a 5/8" gap appeared between the frame and the front of the grate (Photo 21). A piece of steel was brazed to the rear cross member of the extension frame to prevent the grate from receding (Photo 22). (Subsequently, the extension frame was redesigned to include cast stops on the rear cross bar.)

After three years exposure to traffic (AADT 37,600-21% trucks), the extension frames were removed, inspected, and put back in place (Photo 23). All 4 units were in excellent condition and have been problem-free after 9 years of service.

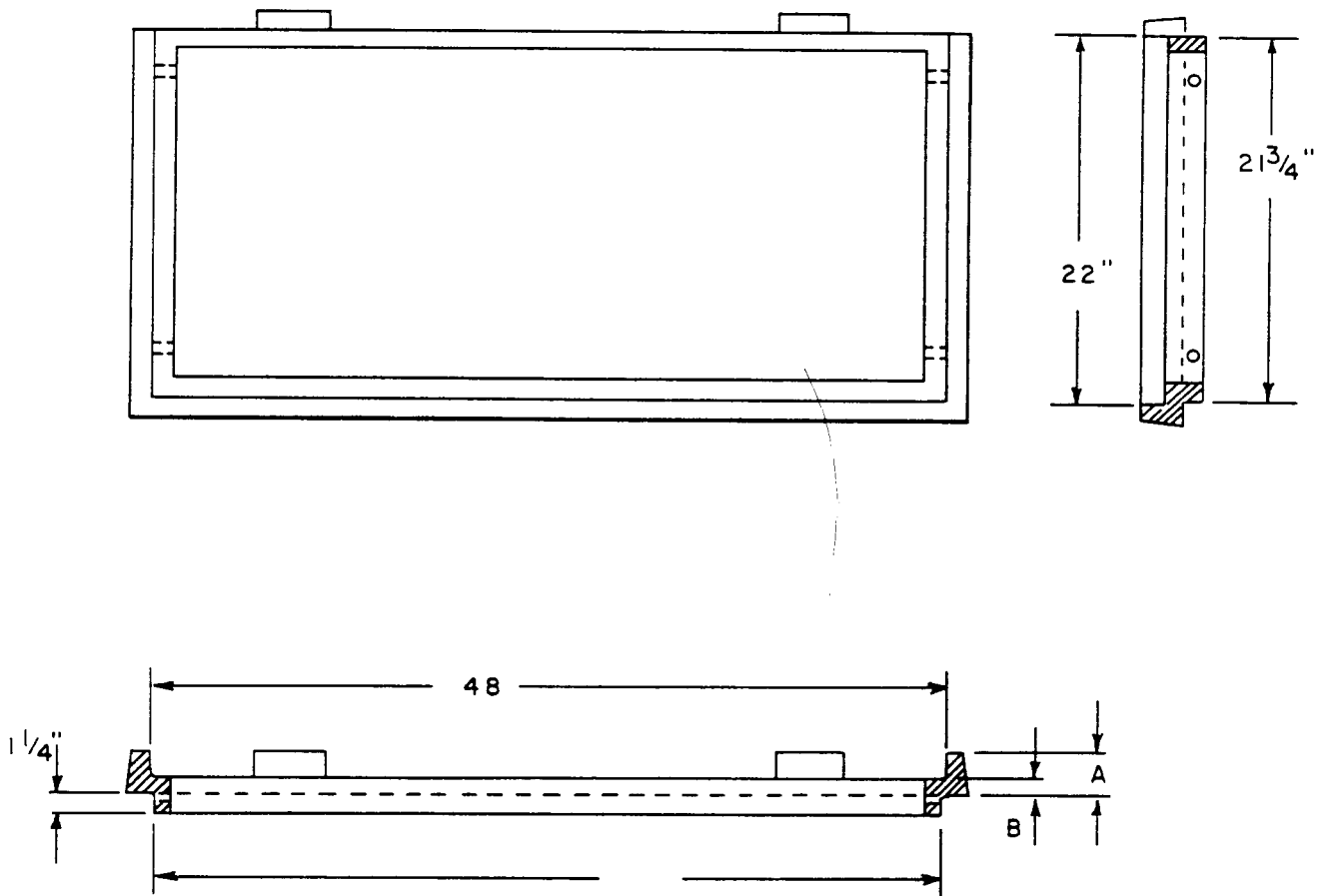

FIGURE 3:
IMPROVED EXTENSION FRAME DESIGN
(TYPICAL)



PHOTO 17
APPLYING BEDDING COMPOUND



PHOTO 18
FINISHED BED



PHOTO 19
DRILLING TO "DIMPLE" OLD INLET FRAME



PHOTO 20
BOLTING OF INLET EXTENSION FRAME TO OLD "HEAD"

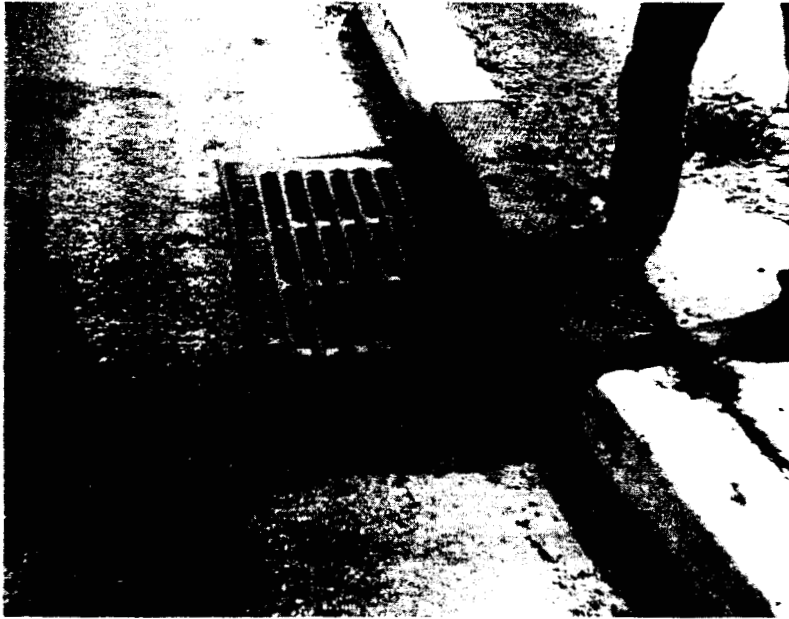

PHOTO 21
OPENING BETWEEN GRATE AND FRAME



PHOTO 22
BRAZED STOP TO PREVENT GRATE FROM RECEDING

PHOTO 23
INSPECTION OF IN-SERVICE INLET EXTENSION FRAME



a: LIFTING OUT GRATE



b: REMOVING EXTENSION FRAME



c: INSPECTING EXTENSION FRAME



d: REPLACING EXTENSION FRAME



REPLACING GRATE

The use of extension frames precludes the necessity of removing the curbing, resetting the old frame, the placement of new curbing, and in many cases, the cost of a new curb piece. Less obvious benefits over the old method of raising a "head" is uninterrupted drainage and driver comfort.

2) Installation of Extension Rings

The first installation of extension rings in this research was made on Route 27 in Princeton N.J. on July 2, 1979, using an epoxy as a bedding and bonding agent to speed up installation time. This experiment involved raising five utility manholes and was conducted in conjunction with the N.J. Bell Telephone Company.

At the first location -- to the surprise of all -- it was found that an extension ring was already in place. This ring was removed and all mating surfaces were wire brushed, the epoxy applied to the frame, and the ring replaced. A second (new) ring was similarly treated and nested into the first ring. The other four raisings involved single ring applications. Installation time for cleaning, applying the epoxy, setting the ring and cover was 16 minutes. All rings, including the double set, have given 6 years of satisfactory service.

The second test of extension rings was a maintenance resurfacing on Route 93 in September, 1980. This project extended through the municipalities of Ridgefield, Leonia, and Englewood in Bergen County. This resurfacing project was almost cancelled out of concern for the length of time it would have taken to raise the 102 manholes by the conventional (brick and mortar) method, which would have extended the paving into late December. Research suggested the concept of using extension rings and it was accepted by the Maintenance Division, with Research assuming the responsibility for measuring, ordering and supervising the installation.

The sizes and cover thicknesses of manholes varied in each municipality, as did those of the Department, county, and sewage authorities. Some of the units dated back to 1918. The condition of the existing frames varied from good to bad, exhibiting various degrees of deterioration and wear. Some of the frames were cracked, some were spalled from snow plowing (Photo 24), others badly corroded from decades of exposure to sewer gases and/or oxidation (Photo 25). Upon measuring all the manholes, it was found that there were 12 different diameters with 4 different cover thicknesses. By using a system of 8 spacers (3/4" long x 1/2" wide x 1/8" thick) cast about the periphery of the lower section of the extension ring (see Figure 4), we were able to halve the number of diameters as measured. These spacers served two functions; it removed side play, and helped center the extension ring in the old frame. In the case of an out-of-round frame (old, hand-molded castings), grinding one or two of the spacers would insure a snug fit. Cover thicknesses ranging from 1" to 2" for the various diameters would have necessitated the manufacture of 25 patterns to make the castings (\$750 ea.). By designing an extra-strength 1" cover, the number of patterns was reduced to six. On manhole frames with worn seats, a concave surface is formed between the seat and the sidewall of the frames. In order to permit solid mating of the horizontal surfaces, a 1/4" chamfer was cut about the periphery of the bottom of the extension ring (see Figure 4).

Note: Overlays of 1½ - 2" require the use of a 1" cover. Extension rings for use with the thinner overlays have anchor lugs protruding from the upper periphery of the ring (see Figure 4).

A work train was devised consisting of a safety truck up front towing a compressor, a front-end loader containing the extension rings in the middle, and a pick-up truck in the rear for protection. The truck driver and one man would remove the covers and blow out the dust which had accumulated between the

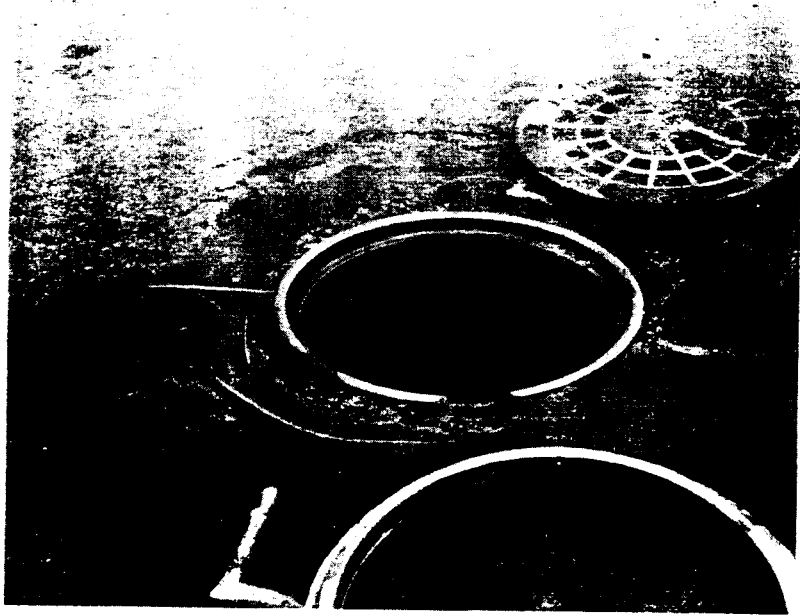
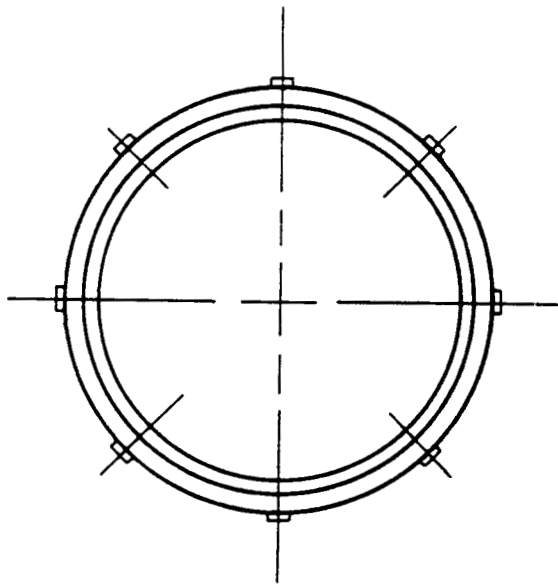

PHOTO 24
SPALLED MANHOLE FRAMES - ROUTE 93 PROJECT



PHOTO 25
CORRODED SANITARY SEWER MANHOLE FRAME



CAST IN SPACERS
FOR SLIGHTLY LARGER
OR OUT OF ROUND
MANHOLE FRAMES

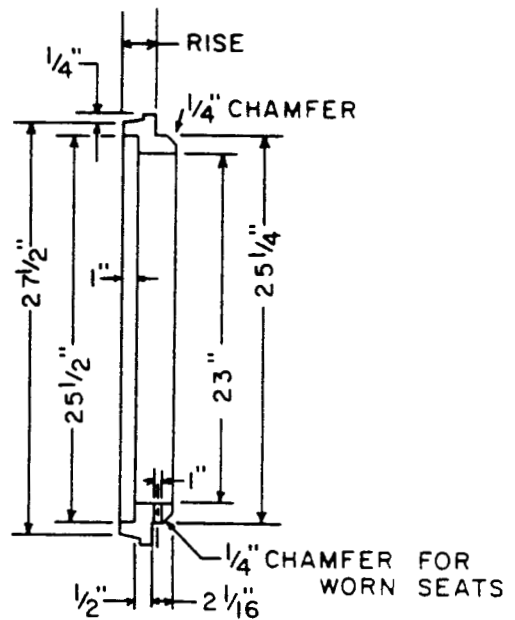
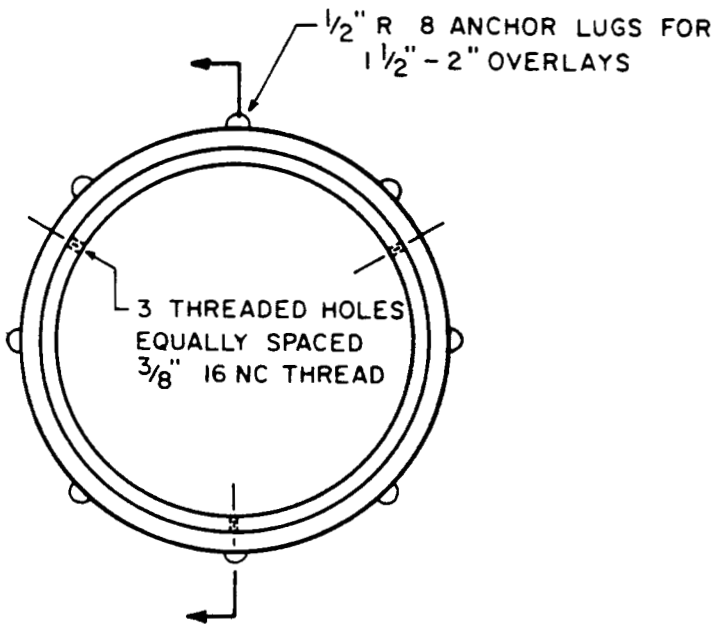

FIGURE 4

SECTION A-A

DESIGN OF SPACERS FOR WORN
MANHOLE HEADS

cover and the frame. A pneumatic drill having a wire wheel was used to clean the manhole frame and extension ring (Photo 26). Both pieces were then degreased by wiping the surfaces with a rag or industrial waste saturated with trichlorethylene (Photo 27). The ring was inserted in the frame and checked for best fit. The ring and pavement were then indexed with a lumber crayon. While the ring was being checked for fit, another person was mixing the epoxy bonding and bedding compound (Photo 28).

The bedding/bonding compound used in this work is a two-part epoxy adhesive system in a self-contained polyethelene mixer/applicator cartridge. (See specifications in Appendix C.) The use of a prepackaged kit eliminates the human error often found in measuring two component mixes in the field. The epoxy is applied to both the seat and upper surface of the frames (Photo 29), the ring is placed in the indexed position, and the new cover inserted. Total time for installation of the extension ring ranged from 13 to 20 minutes. The expended mixer/applicator was placed in the front-end loader to check for set before placing the bituminous ramp around the raised ring.

During the author's absence, three short rings were placed in deeper frames, leaving a 1/2" gap between the seat and the bottom of the extension frame (Figure 5a). This meant that 3 of the longer rings would have to be placed in shallower frames (Figure 5b). In both cases, only one surface would be epoxy bonded. To increase the bond, a bead of epoxy was placed along the sidewall of the frame. This method should be considered as an exception rather than the rule, i.e., use only if it would require a new pattern for one or two extension rings on a given project. The use of extension rings permitted this resurfacing project to be completed by November 21, 1980, six weeks ahead of the estimated schedule.

The following paving season, the use of extension units was implemented on a project-by-project basis. Minor problems occurred in the field which were



PHOTO 26
WIRE BRUSH CLEANING OF EXTENSION RING



PHOTO 27
DISASSEMBLING THE EXTENSION RING



PHOTO 28
MIXING EPOXY BEDDING AND BONDING COMPOUND

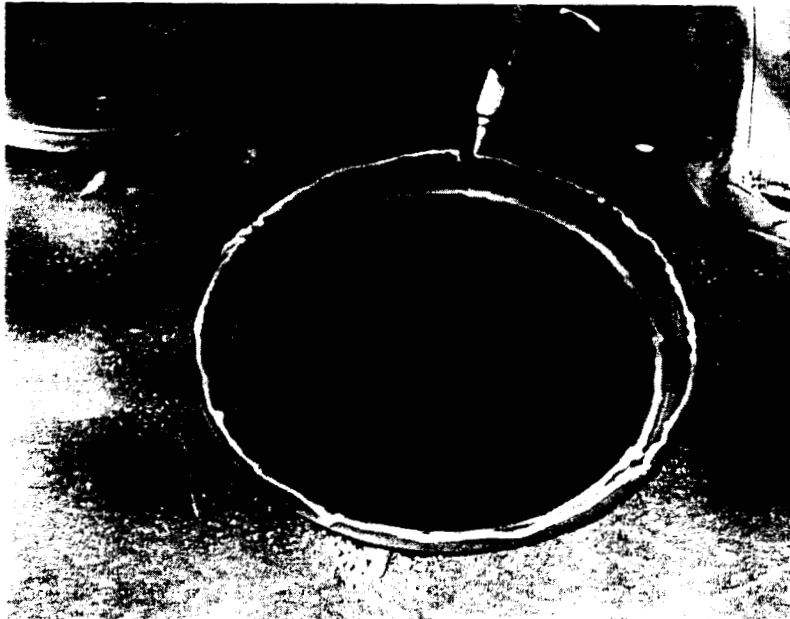

PHOTO 29
APPLYING EPOXY TO SEAT AND UPPER SURFACE OF MANHOLE CASTING

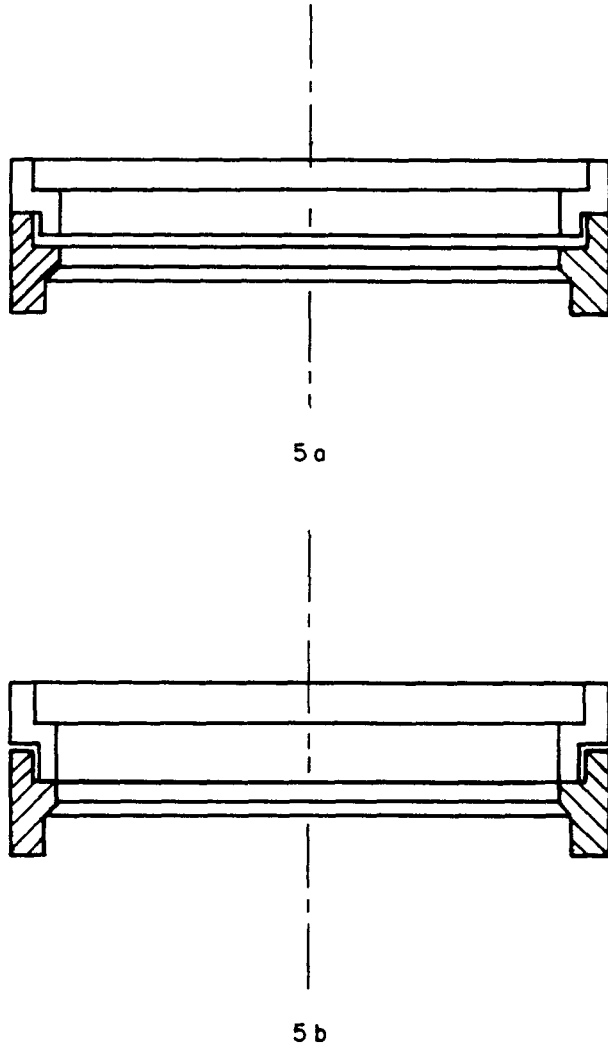

FIGURE 5 :
IMPROPERLY FITTED MANHOLE COVERS

quickly resolved (i.e., worn frames and iron covers, improper selection of height, improper cleaning technique). Most of the problems incurred were due to the unfamiliarity with this new system on both the part of the contractor and state personnel.

A treatise outlining the problems that may occur in the field, how the problems are to be addressed, and a set of guidelines for design engineers, is found in Appendix D.

E. Reflection Cracking

1) Background

Reflection cracking of asphaltic overlays placed over portland cement concrete pavements has been a problem confronting maintenance forces over the past five decades. Photo 30 shows the various manifestations of the problem. As discussed previously, a critical review of the literature suggested that the saw and seal technique offered the greatest promise for providing a definitive solution to this problem.

The saw and seal procedure apparently was first suggested in 1952 by Bone⁽⁸⁾ of MIT. He recommended "...that grooves be sawed in the resurfacing over joints in the concrete and that these saw cuts be filled with elastic material" as a solution to reflection cracking. Unfortunately, this suggestion was not tested in his work. Later work at MIT on joint sealant designs and materials by Tons^(9, 10) led the Connecticut Highway Department to experiment with sawed joints in bituminous concrete overlays. In 1958, two experimental sections were placed, sawing 3/8" width x 1-3/4" deep cuts over the transverse joints in the underlying concrete pavement. The sawed joints worked well, but adhesion failure of the sealer occurred. In 1960, a third experimental section was placed using five different joint shapes. Wilson⁽¹¹⁾ reported "...because it

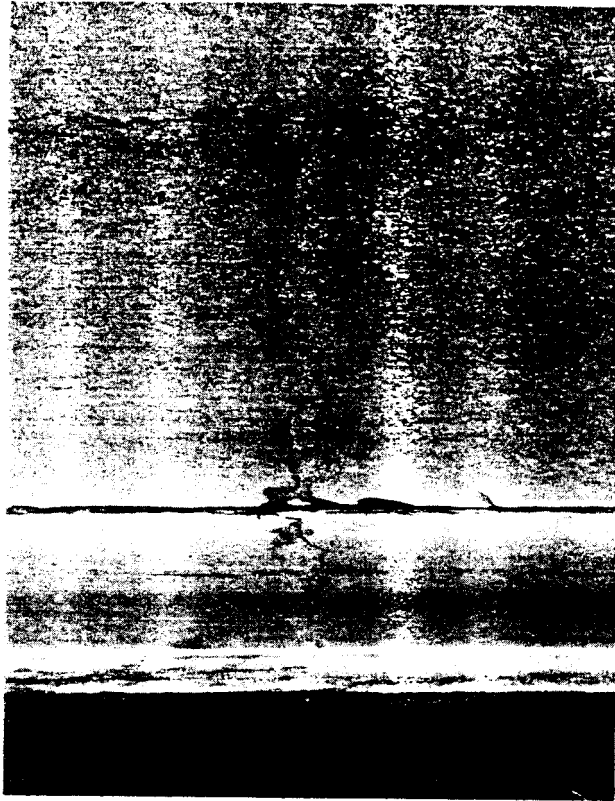

a1 : CENTERLINE CRACKING

b1 : EDGELINE CRACKING

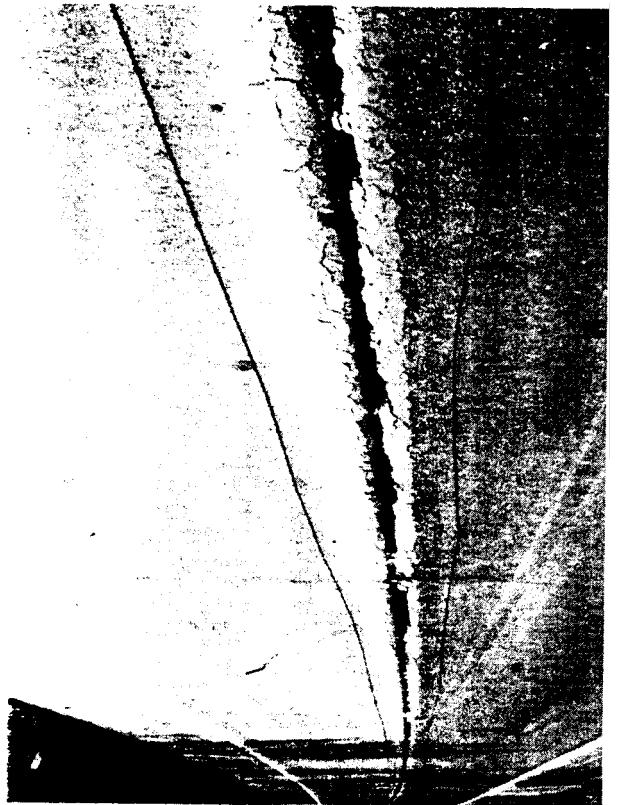

TYPES OF REFLECTION CRACKING

PHOTO 30

was too early to draw valid conclusions from the 1960 tests, it can be only stated that the 3/8" by 1/2" joint appears to control the location of the reflection crack as efficiently as the other shapes. Considerable variation in adhesive failure between replicate sections of the same joint shape raises the question of influences other than the joint shape." In all of these Connecticut experiments, delays (up to two months) in sawing the joints resulted in some reflection cracking occurring before sawing.

2) Location and History of Test Section

New Jersey first used the sawing and sealing technique as an experimental feature in a maintenance resurfacing contract on the westbound lanes of U.S. 22, Sec. 10D, 11J in 1977.

Like many New Jersey highways, the roadway cross-section was changed several times during its life. The existing cross-section in 1977 is shown in Figure 6a. In the 1977 contract, the roadway was to be widened 3' to increase the inside shoulder and provide for two full 12' driving lanes (Figure 6b). Since 3' of the existing shoulder was to become mainline pavement, the shoulder was excavated and bituminous stabilized base was placed in two lifts, which totalled 9" at the concrete pavement interface and 7" at the curb line.

To preserve the curb reveal of the concrete median barrier, it was necessary to mill off 2" of the overlay. Milling also served to remove the patch material and rid the surface of the spalled, raveled and delaminated areas over the transverse and longitudinal joints. (Photos 31 and 32 illustrate the type of distress that occurs when the joint of untied concrete lanes occurs in a wheelpath.)

One of the consequences of the 3' widening of the outside lane was that when a truck traveled over this lane, one of the dual wheels would be on the

EXISTING TYPICAL SECTION
LANE LINES

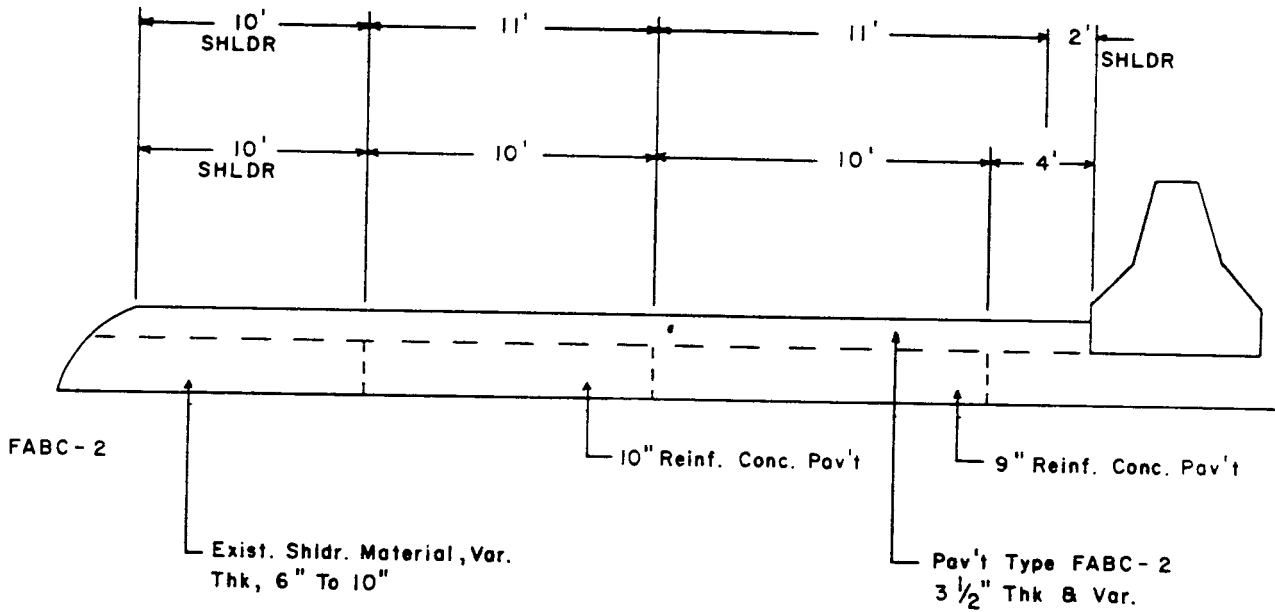

6 b

AS RECONSTRUCTED

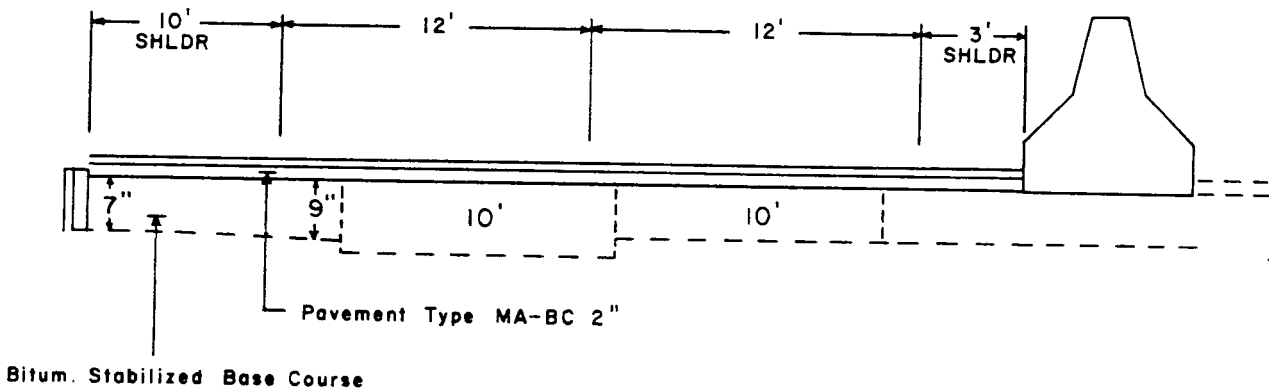

FIG. 6
TYPICAL SECTIONS FOR
ROUTE 22 TEST PROJECT

REFLECTIVE CRACKS

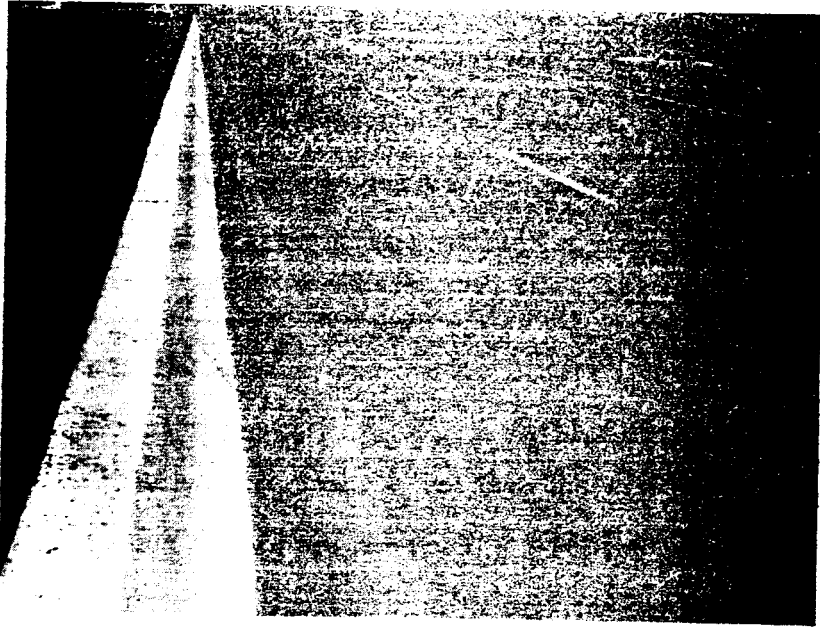

FIGURE 1

AS-CONSTRUCTED SUPERPAVEMENT OVERLAY



APPEARANCE

FIGURE 2

composite pavement (cement base-bituminous overlay) and one wheel would be on the full bituminous section. From previous experience, it was expected the overlay at this interface would be very susceptible to reflective cracking. Hence, this was an ideal place to test the effectiveness of the longitudinal saw and seal system on an offset edge joint.

3) Design of Test Sections

Four different saw and seal test sections totaling 2540' were placed between Sta. 134+05 and Sta. 159+45. Each test section was approximately 650' long and employed a different type of pretreatment of the milled surface in order to determine what level of rehabilitative effort would be necessary to successfully prevent reflection cracking in the overlay. The various test techniques (shown in Figure 7) were as follows:

Technique A: This procedure involved the most intensive effort. After milling, a 20" width of the bituminous base course was removed to the concrete over all transverse and longitudinal joints. The joints in this concrete pavement were cleaned and sealed with a rubberized joint sealer. The cut-out section was refilled with new MABC. The refilled MABC was saw cut (3/8" wide x 1/2" deep) and sealed with a rubberized bituminous joint sealer. After placement of the MABC surface course, a 3/8" x 1/2" saw cut was made over all underlying joints and sealed.

Technique B: The process was the same as (a) above except the joints in the underlying concrete pavement were not cleaned and sealed.

Technique C: The process was the same as (b) above except the MABC inlay was not cut and sealed.

Technique D: The last and least work intensive effort was to merely cut and seal the newly placed 2" MABC overlay over the underlying concrete joints.

FIGURE 7: ALTERNATIVE SAW AND SEAL TREATMENTS

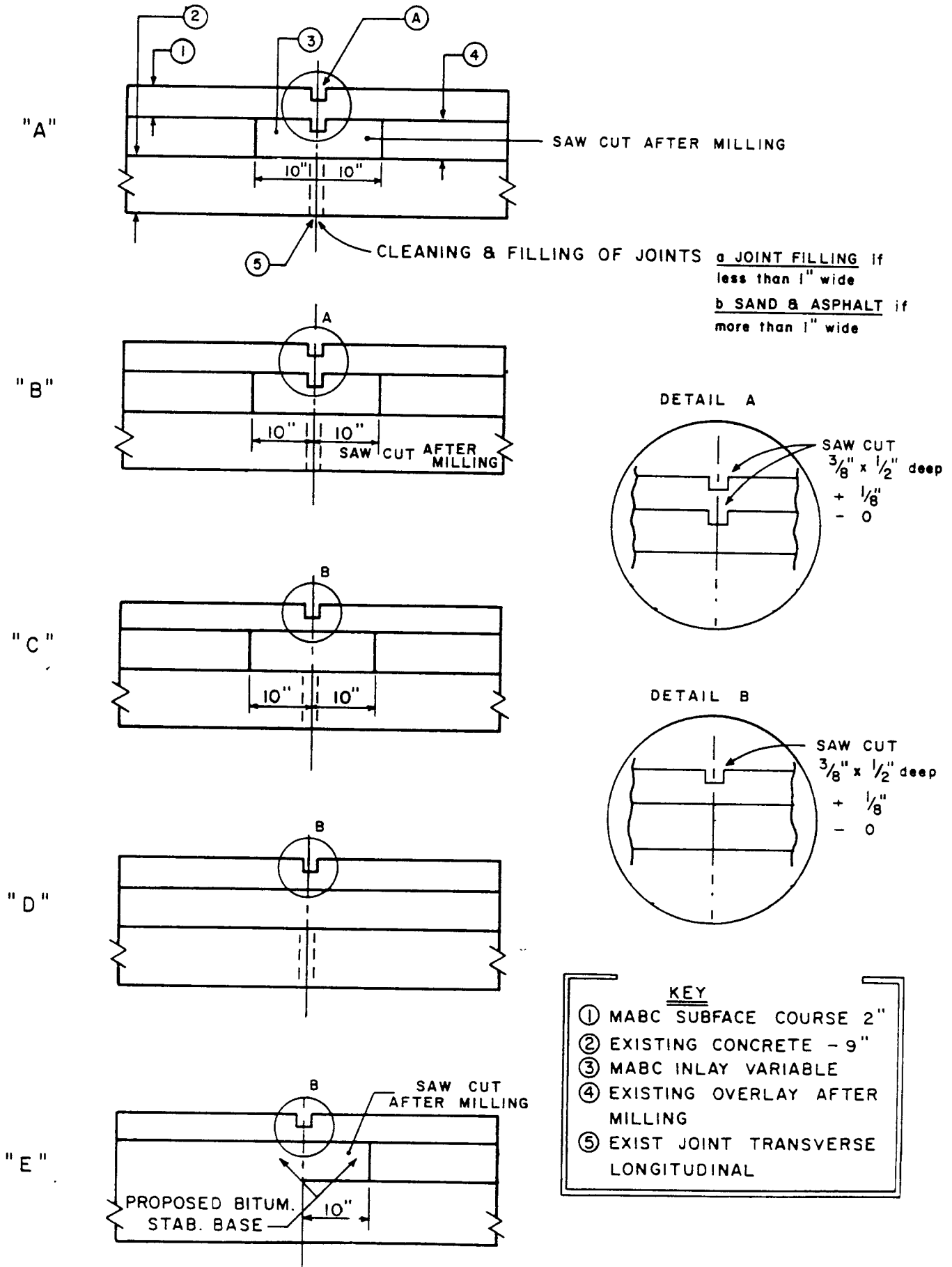

One other precaution was taken in these test sections, that is the edge of the milled pavement was cut back 10" from the composite pavement-bituminous pavement interface (see Technique E, Figure 7). This precaution was taken prior to excavation of the shoulder to eliminate the loose and/or jagged edge produced during excavation. Examples of the forementioned are shown in Photos 33 and 34. The balance of the 7-mile overlay on both sides of the test section served as control.

4. Sawing

a) Dry Cutting: Sawing commenced in the inside lane with a dry abrasive blade and the joint was blown clean with compressed air. Traffic in the outside lane blew the dust back into the sawed joint. When left in this condition overnight, any pickup of moisture consolidated the dust and made it difficult to remove the following day. The dust subsequently acted as a parting compound preventing adhesion to the bituminous matrix, i.e., the sealer could be pulled out of the joint like a piece of rope.

To seal directly behind the sawing operation would appear to be the solution. This, however, slows the operation and a totally clean joint is still not assured. Another reason for avoiding dry cutting is blade wear. The blade not only wears rapidly (causing a tapering shallow cut), but the edges tend to round giving a U-shaped joint.

b) Wet Cutting: The following day, the method was switched to wet cutting under the following provisos: 1) the joint be flushed with a pressurized stream of water, 2) the joint be blown dry with compressed air, and 3) the joint be blown clean and dry before sealing. This method was far superior to dry cutting since the water flushes the asphalt and stone dust to the side of the road out of harms way. Two days production of saw cutting preceded the



PHOTO 33
EXAMPLE OF JAGGED EDGE DUE TO EXCAVATING



PHOTO 34
JAGGED EDGE CUT BACK OVER CONCRETE ON ROUTE 10

sealing operation, so that by the end of the third day, the experimental section was completed (5/25/78).

5. Condition Surveys

a) Transverse Joint: Condition surveys of the test sections were made once or twice a year from 1979 to 1984. After the first winter, reflection cracking occurred over 23% of the joints in the control section and on one joint (0.9%) in the test section. After seven years, reflection cracking over the joints increased to 59% in the control section and 2.9% in the test section. Photos 35 and 36 demonstrate the condition of the test and control sections after seven years of service.

Two of the reflection cracks occurring in the test section were due to decayed concrete at the joint, i.e., soft concrete removed, and filled with bituminous mix. The joint was sawn at the correct location, however, the tendency is to crack at the rigid structures (concrete slabs). Photo 37 shows the development of the crack. A core taken over the crack (Photo 38) proved that the crack occurred at the concrete/bituminous patch interface. The left half of the core exhibits a smoother texture (placed on concrete) while the right half shows some of the patch material sticking to the overlay. The third joint failure was due to corner cracking. Corner cracks like those shown in Photo 39 will be troublesome to the absolute success of the saw and seal method of controlling joint reflection cracking. They can be treated either before or after the crack occurs. In the first case, the corner should be removed, the slab dowelled and patched with a quick-setting cement. In the latter case, let the crack develop and then rout (3/8" x 5/8") the crack or preferably saw (with a random crack saw), and seal it. Except for these three joint cracks, there were zero failures in the 100 remaining joints in the test sections.



PHOTO 35
TYPICAL APPEARANCE OF ROUTE 22 AFTER 7 YEARS SERVICE

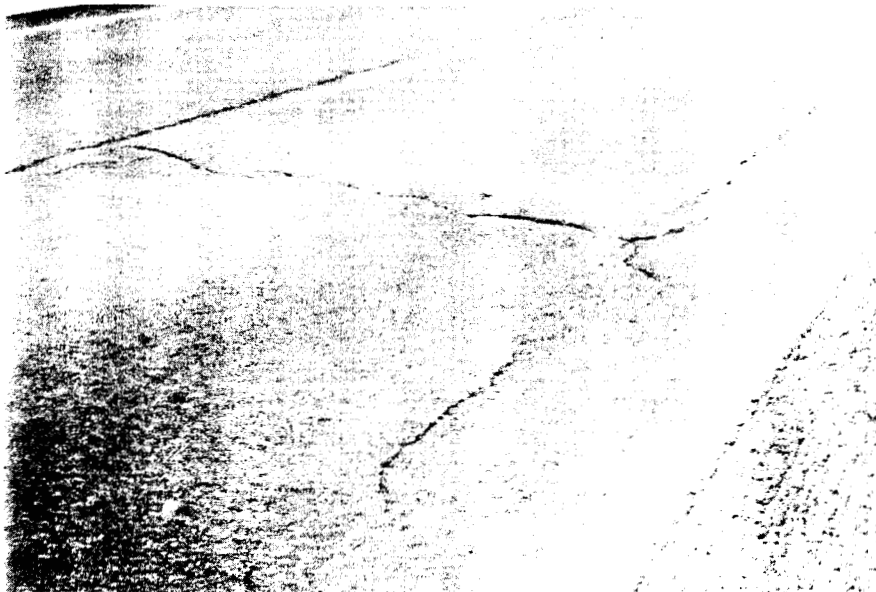

PHOTO 36
TYPICAL REFLECTION CRACKING IN CONTROL SECTION

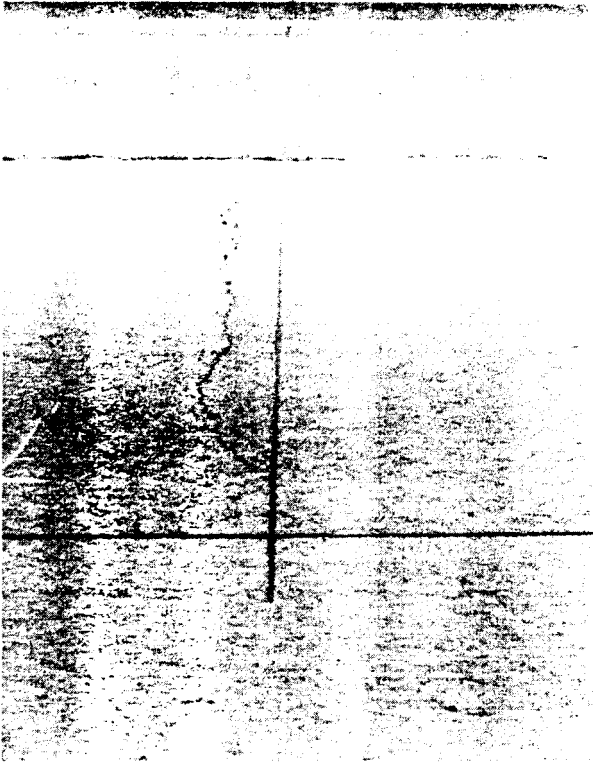

PHOTO 37
CRACKING OF REPAIRED SLAB



PHOTO 38
CORE OVER CRACK REPAIR

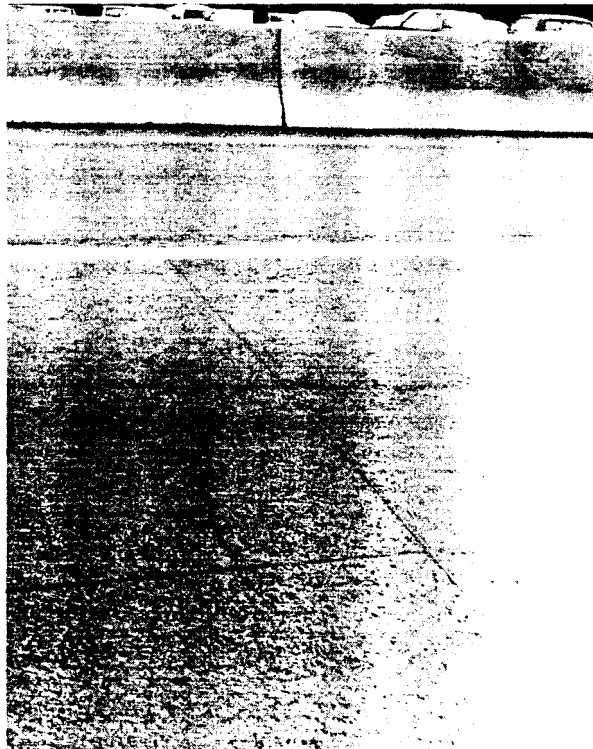

PHOTO 39
CORNER CRACK

b) Longitudinal Joints: Three longitudinal saw cuts were made over the underlying concrete pavement. Two were over the untied concrete lanes, the third over the edge of outside lane. Photo 40 shows the uncracked edge joint in the test section and Photos 41 and 42 show the open edge joint forming in the control section after seven years of service. During this period approximately 6000' of cracking occurred in the control section and none in the test section. (All of the longitudinal and transverse reflection cracks in the control section were sealed by Maintenance during the winter of 1984.) The sawn joint in the vicinity of the inner shoulder (Photo 43) is also performing very well. Photo 44 is shown for comparison purposes of what happened to the previous overlay after about twelve years.

The performance of the joint between the inside and outside lanes is worthy of further explanation. This entire construction joint ("cold" joint) over the whole project began to open up within a two-year period. During the first year (Photo 45), skeptics believed that it was the joint in the underlying concrete that caused the failure and that the contractor did not properly reference the joint. The data proved differently. That is, cores taken over the sawn joint showed it was directly over the underlying concrete joint. This was substantiated in the control section, where a second crack formed parallel to the cold joint in the overlay (see Photo 46).

From prior experience it was known that a bituminous shoulder placed against concrete slabs would crack at expansion joints. In an effort to determine how far a crack would penetrate the shoulder area, the transverse cracks were carried out 6", 10", 18", and 36" beyond the longitudinal edge joint. In every case where there is a working joint, the crack propagated beyond the end of the sawn joint (see Photos 47 & 48). A suggestion of the author was to core drill a 1-1/2" hole at the end of the joint and fill it with sealer (similar to what is done in

EDGE CRACK FORMATION IN CONTROL SECTION

PHOTO 42

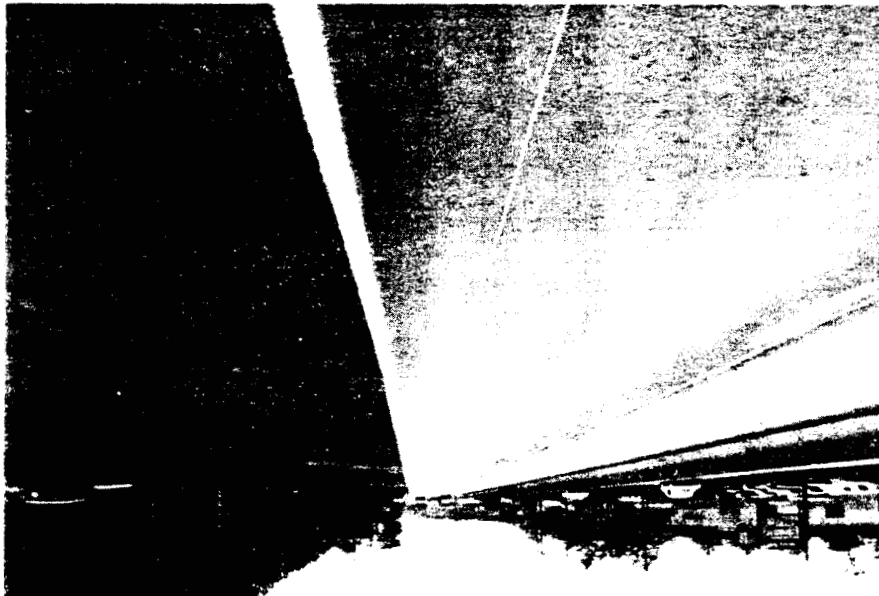

PHOTO 41



LONGITUDINAL SAW AND SEAL EDGE JOINT IN TEST SECTION

PHOTO 40



TEST SECTION



PHOTO 43

APPEARANCE OF LONGITUDINAL JOINT ON ROUTE 22 AFTER 7 YEARS SERVICE



PHOTO 44

APPEARANCE OF LONGITUDINAL JOINT IN PREVIOUS OVERLAY

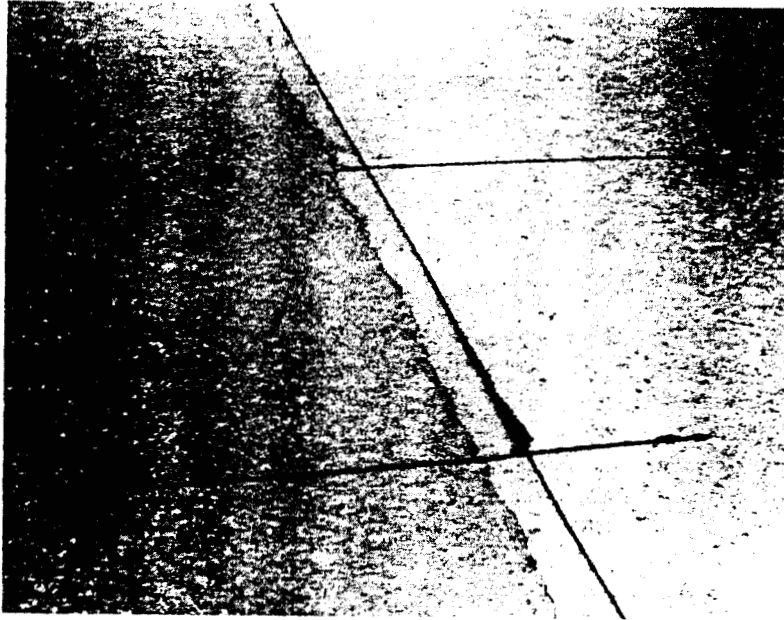

PHOTO 45
COLD JOINT IN TEST SECTION

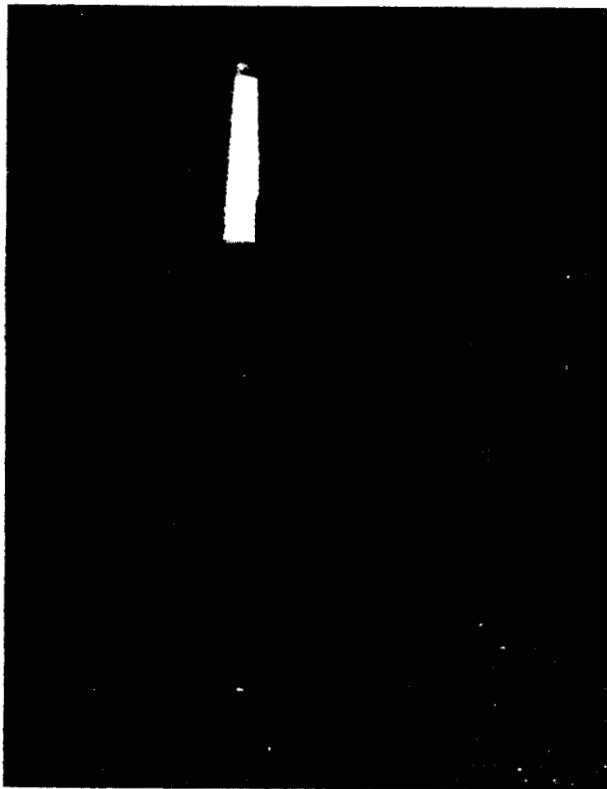

PHOTO 46
COLD JOINT AND REFLECTION CRACK IN CONTROL SECTION



PHOTO 47
CRACK PROPAGATION



PHOTO 48
CRACK PROPAGATION

metal) to prevent propagation of the crack. It appeared that the simpler solution was to saw cut the full width of the shoulder.

All four of the designed test sections from the most labor-intensive effort to the least intensive effort demonstrated the same performance in controlling reflection cracking. The least intensive effort was recommended for implementation in 1984.

c) Implementation: The first two major projects on which the saw and seal method was implemented were first generation resurfacings. These projects were monitored by Research and were not without problems. The first (in 1984) was a 3" overlay on Route 40 & 322 which incorporated 138,000' of sawing and sealing. The saw and seal was put into the contract through a change order by addendum. It took three months to issue the change order, thus delaying implementation of the sawing and sealing until fall. To preclude freezing of the water used in a wet sawing operation, dry sawing was reluctantly permitted. During this period of delay, approximately 55% of the project had been resurfaced and reflection cracking started to occur. The extreme irregularity of the reflection joints (Photo 49) dictated that the joints be routed rather than sawn. Another problem was unaligned transverse joints, due to frozen or bituminous repaired joints. Each joint more than 3/4" out of alignment from the adjoining lane was saw cut individually (Photo 50). As a result of this project, several important points were learned:

1. Time is of the essence: A delay of more than two weeks between placement of the binder and top course will result in reflection cracking in the binder and influence cracking in the top course.
2. The sealing of cracks and joints in the existing concrete appeared to be necessary only where the material was missing or badly eroded (the original quantity of joint sealing of 91,000' was reduced to 15,500' for

PROJECT

UNALIGNED

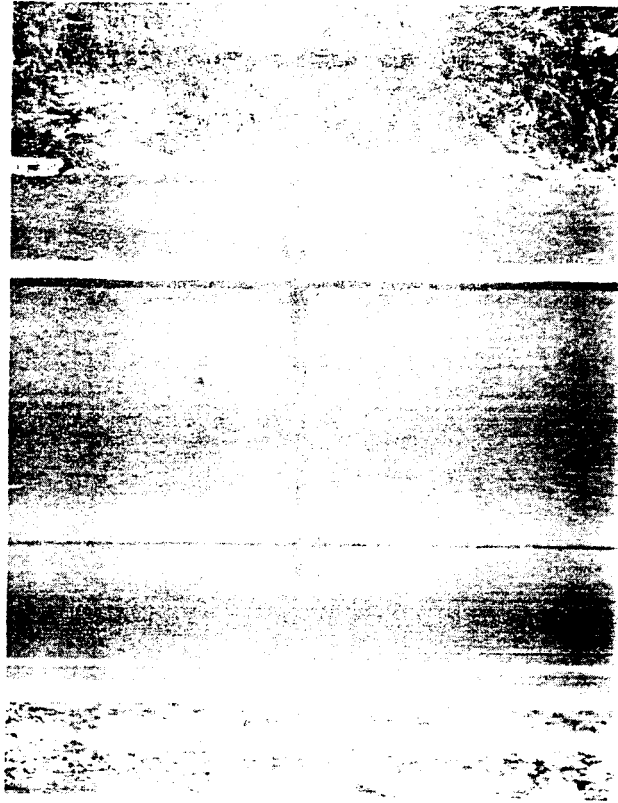

(EARLY REFLECTANCE DATA (RECENTLY ROUTED))

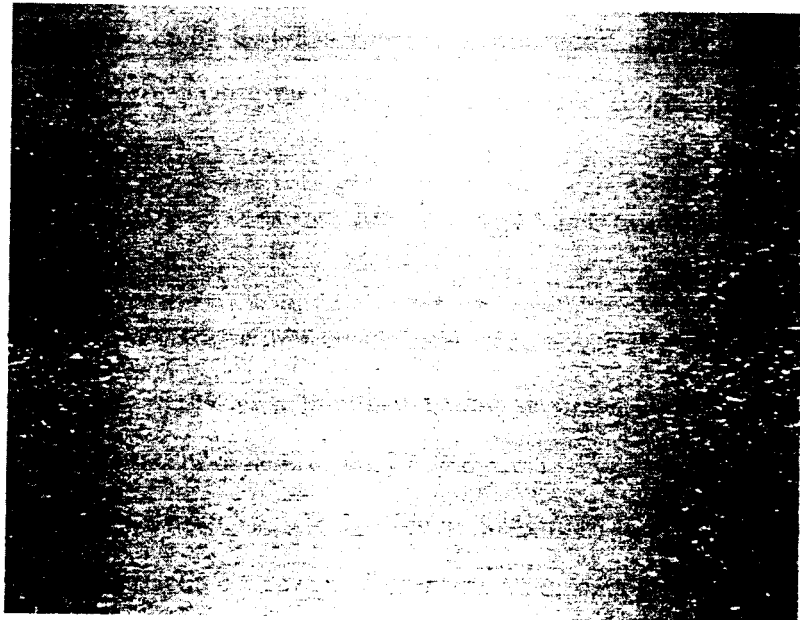

the control section, resulting in a saving of over \$79,000). (A more in-depth discussion of joint placing/sealing practices and needed modifications is presented in Appendix E.)

3. Joints exceeding 1-½" in width should receive special treatment, i.e., build up the joint with a bituminous fiber board to support the overlay. (See Appendix E.)
4. Do not permit dry sawing; wet saw only when temperature is 35°F and rising.
5. Do not permit routing. In coarse mixes, the router tends to tear out the coarse stone giving a shoddy appearance. Use a "Random Crack Saw" (e.g., Cimline's "Random Crack Saw" shown in Photo 51).
6. On first generation overlays, increase the width of the saw cut to 1/2" wide x 5/8" deep. It is hypothesized that the thinner the overlay, the more the underlying pavement will be influenced by the ambient temperature, i.e., expansion-contraction. The increase in the width of the sawn joint will reduce the cohesive stresses in the sealer on contractions of the pavement, thereby reducing the stresses applied at the sealer-asphalt concrete interface.
7. The sealing material should be applied by a special "Wand" having the shut off valve within 4" of the tip. A sealing pot either hand or wheeled should not be permitted. Both the regular wand and the pouring pot have been responsible for both under-and overpouring (see Photos 52 and 53).

With the inception of the weakened plane system (saw and seal), the author concluded that the general concept of the last twenty years of using softer asphalts is in error. That is, it would appear that when the cut and seal system is used, a hard asphalt pavement below the point of brittleness could be used

CIMLINE "RANDOM CRACK SAW" MODEL RCS-16

DEPTH CONTROL
Adjustable depth control accomplished by hand control with locking nuts.

Phone (612) 929-0431
Toll Free 1-800-328-3874

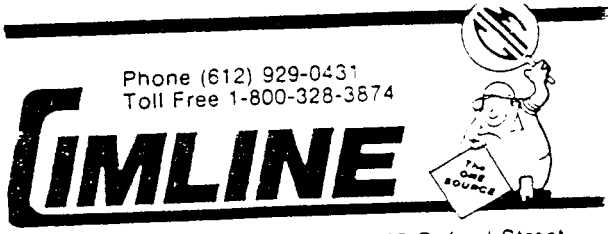

CIMLINE

Construction Materials, Inc. 6725 Oxford Street
Minneapolis, MN 55426

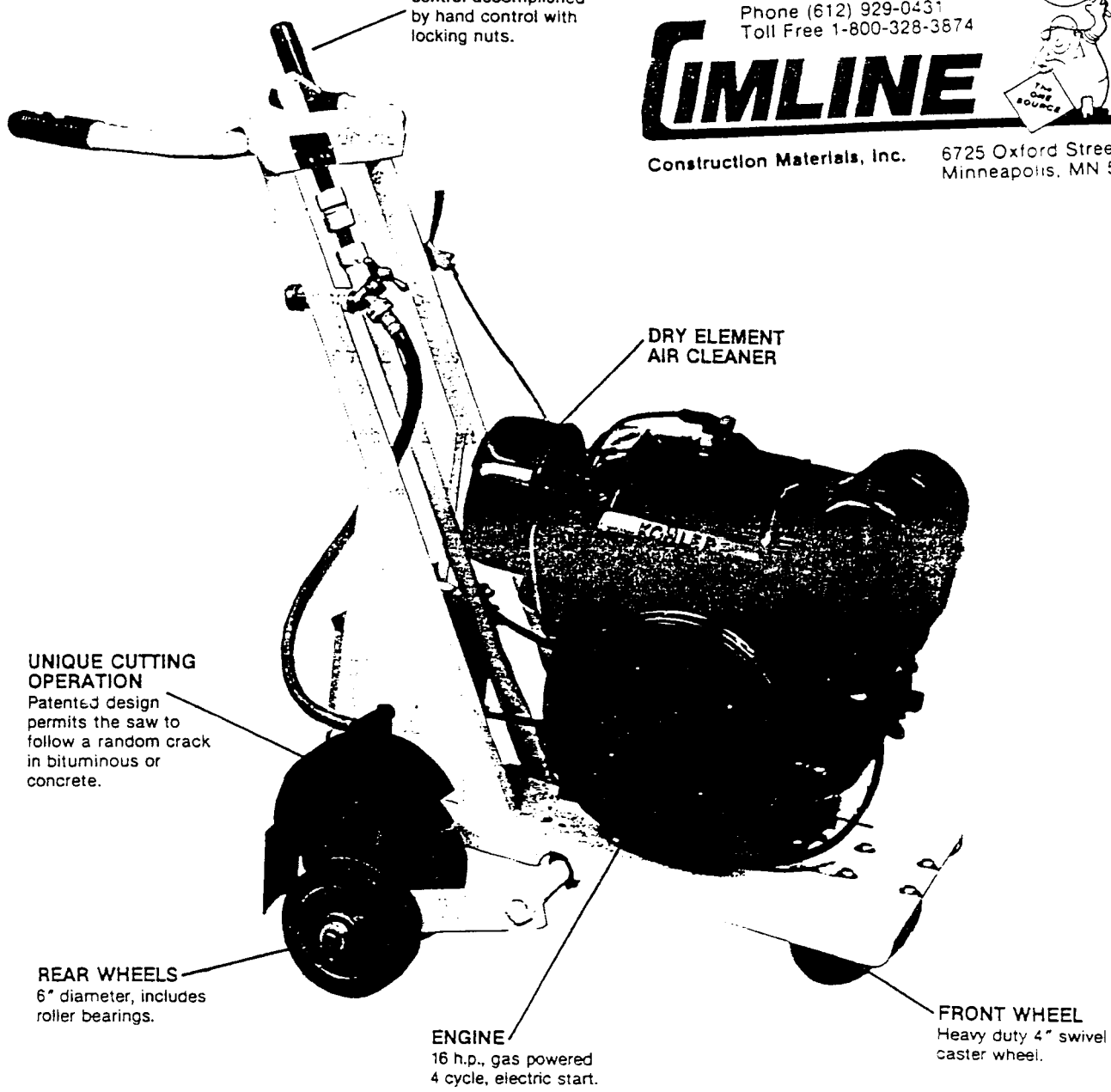

UNIQUE CUTTING OPERATION
Patented design permits the saw to follow a random crack in bituminous or concrete.

REAR WHEELS
6" diameter, includes roller bearings.

ENGINE
16 h.p., gas powered
4 cycle, electric start.

FRONT WHEEL
Heavy duty 4" swivel
caster wheel.

PHOTO 51
RANDOM CRACK SAW



PHOTO 52
UNDERPOURING OF JOINT SEALANT ON ROUTE 40 & 322 PROJECT



PHOTO 53
OVERPOURING ON ROUTE 40 & 322 PROJECT

successfully for the overlayment of portland cement pavements. The rationale here is if the cut and seal system dispenses with the normal distress at joints and increases the useful life of the pavement, this increase in pavement life could be negated by rutting. It is postulated that by using a harder asphalt, the softening point (ring and ball), tensile strength, and stability will be increased, with a consequent reduction in rutting, shoving, and corrugating, particularly at traffic signals. (This theory is currently being evaluated as part of a separate study.)

The second major project implementing the saw and seal system was on Route I-80, Sec. 4BB constructed in the summer of 1985. This pavement will be monitored by Research to test the following hypotheses:

1. To determine if a 2" overlay in combination with the saw and seal system can be successfully used in place of the normal (unsawn) 3" overlay;
2. To determine if an AC-40 will be less susceptible to rutting than an AC-20 asphalt cement;
3. To confirm whether, like on Route 40 & 322, only the missing or eroded joint compound and cracks need be filled before overlayment.

Route I-80, Sec. 4BB is an eight-lane divided portland cement concrete highway having an annual average daily traffic count (AADT) of 109,000 vehicles, 17% trucks. The resurfacing consisted of 231,000 sq.yd. of 2" and variable MABC-1 using an AC-40 and 9834 sq.yd. of 2" and variable MABC-1 using an AC-20 asphalt cement for the control section in the eastbound direction.

Due to the heavy volume of traffic, the project was planned as a night operation, paving one lane at a time. To preclude the formation of a "cold" longitudinal joint (like that which occurred on the test section on U.S. 22), the use of a beveled edge was incorporated into the project as part of a separate study.

The cut and seal technique was applied over the three longitudinal and two edge joints and all the transverse joints on the mainline pavement and ramps. A total of 119,200' were sawed and sealed. A short section between Sta. 143+00 and 150+00 was left for control.

During construction the following problems came to light:

1. Reflection cracking occurred in 10% of the transverse joints in a matter of hours. It had been noted that some joints had been overpoured prior to the resurfacing. It is the author's hypothesis that this cracking occurred as a result of the combination of decreased thickness of the overlay in the vicinity of the joint, together with swelling of the joint sealer caused by the hot bituminous overlay material.
2. Many of the joints were not properly referenced. Photos 54 and 55 show cracks occurring from 2½" to 5" from the sawn transverse joint. The sawn joints are skewed to the left in Photo 54 and to the right in Photo 55. To confirm that the sawn joint was indeed offset, a core was taken over the sawn joint and crack. The core hole in Photo 56 shows the expansion joint to be directly under the crack. A close-up of the core (Photo 57) shows the sawn and sealed joint on the left and the cracked edge with the sealer from the underlying pavement attached.

Longitudinal joints also exhibited poor referencing (Photos 58 and 59). In Photo 58, the sawn longitudinal joint was off mark from 5" at the transverse joint (foreground) to 11" in one slab length.

The sawing of longitudinal joints on a curve was particularly troublesome. If not indexed in small increments of 15'-25' (depending on the radius), the sawed joints form a series of chords; the longer the chord, the less chance that the sawed joint will be over the joint.

ROUTE 80 PROJECT

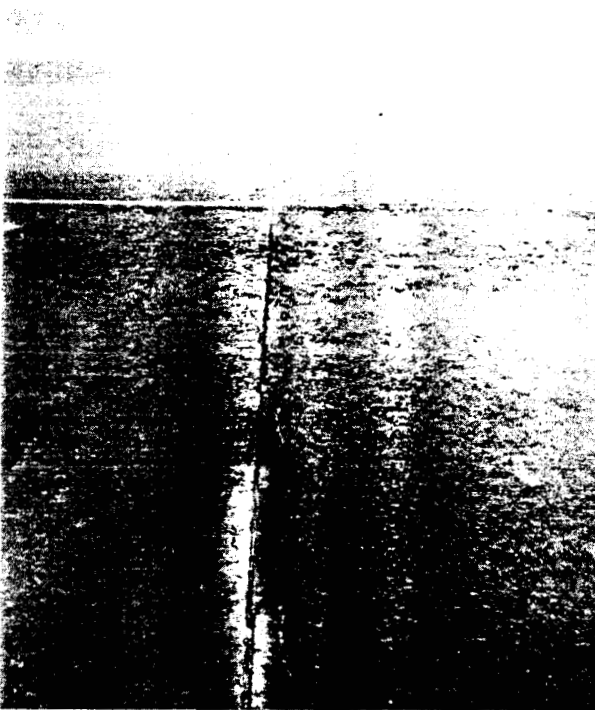

PHOTO 54
IMPROPERLY REFERENCED SAW CUT,
SKEWED TO LEFT

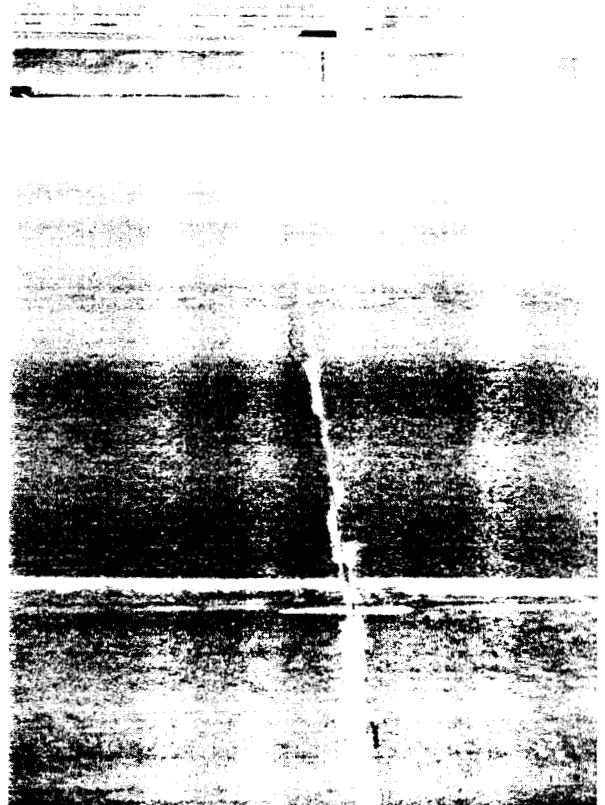

PHOTO 55
IMPROPERLY REFERENCED SAW CUT,
SKEWED TO RIGHT

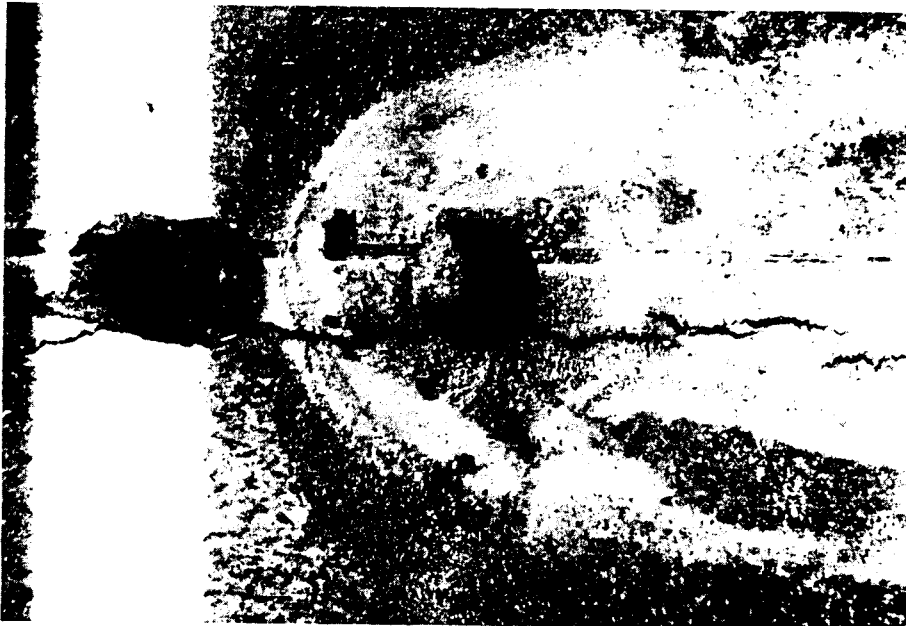

PHOTO 56
CORE TAKEN OVER SAWN JOINT AND REFLECTED CRACK

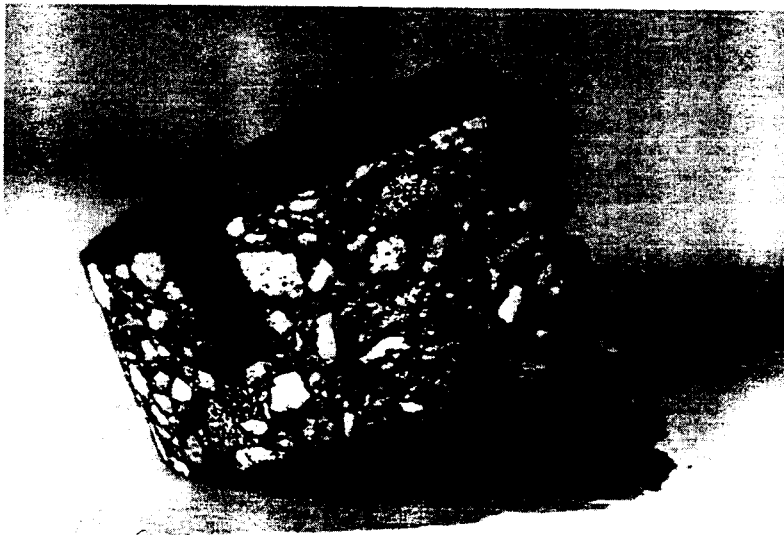

PHOTO 57
CLOSEUP OF CORE SHOWING SEALER ATTACHED



PHOTO 58

ROUTE 80 PROJECT: OVERVIEW OF IMPROPERLY REFERENCED LONGITUDINAL JOINT

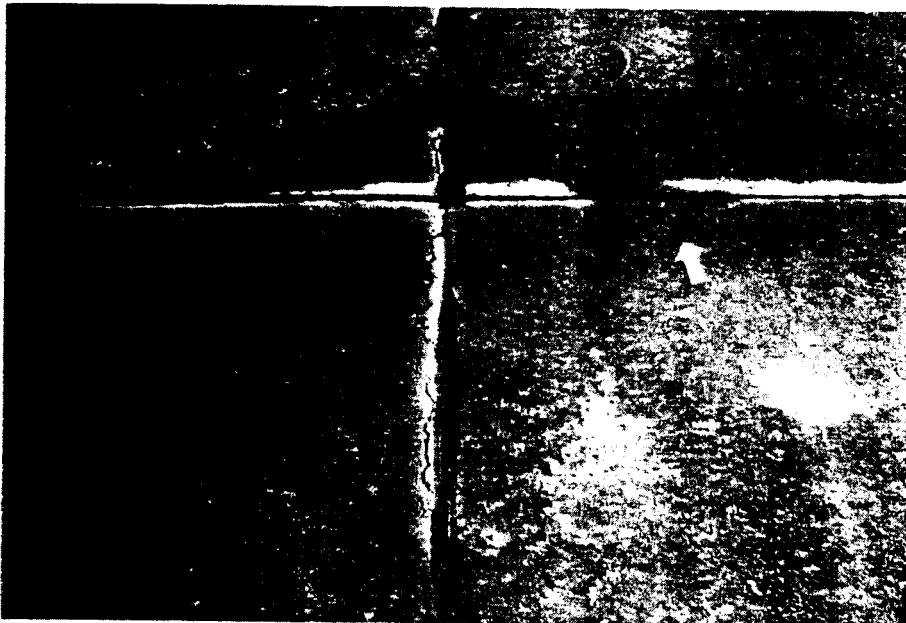

PHOTO 59

ROUTE 80 PROJECT: CLOSEUP OF IMPROPERLY REFERENCED LONGITUDINAL JOINT

The control (unsawn) joints on the project performed as expected: All seventeen unsawn transverse joints reflected through the overlay within two months. Photos 60 and 61 show the I-80 control section. The first and second lanes (background) were inadvertently sawn and sealed; the third and fourth lanes were not sawn.

Results to date suggest the following:

1. It is only necessary to preseal those joints in the underlying pavement where the joint compound is eroded or missing. However, to prevent premature cracking before the sawcutting phase, the joints should be checked for sealer extrusion and the excess either cut off to the pavement level or removed and filled with new sealant. On this project, the plans called for 195,000 feet of joint sealing prior to the overlay. At the suggestion of Research, this quantity was reduced to 25,000 feet, resulting in a savings of \$119,000.
2. The saw cuts should not deviate more than $\pm \frac{1}{2}$ " off of the direct center of the expansion joint.
3. Although early in its useful life, it appears that a single 2" overlay of AC-40 asphalt cement can compete with a normal 3" overlay of AC-20 in providing a smooth ride. Rolling straightedge data indicated that the as-constructed lot percent defective length was only 0.5%, which is indicative of "Good" rideability.⁽³⁾

Suggested specifications for sawing and sealing are presented in Appendix F.

d) Joint Repair: The Department's usual practice in dealing with distressed joints on concrete pavements is to cut off the ends of the slabs two feet on either side of the joint, remove the concrete, and replace with a hot bituminous mix.

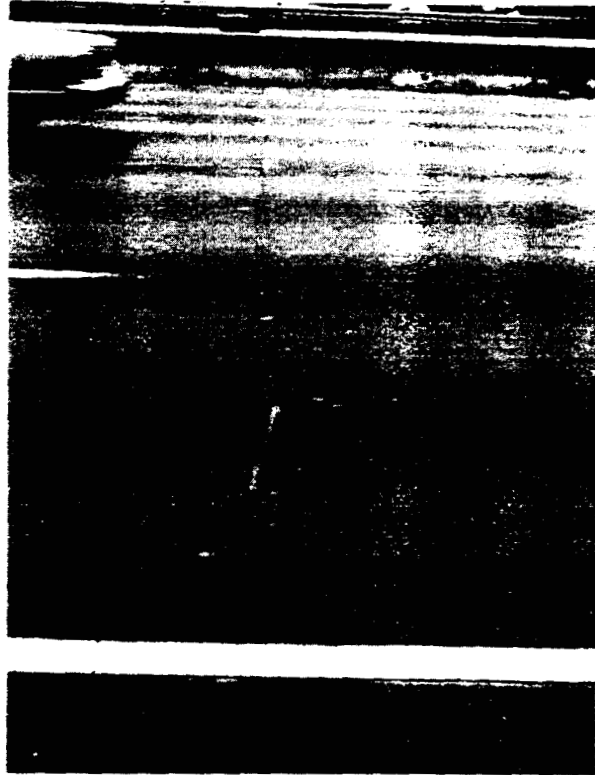

PHOTOS 60 & 61
REFLECTION CRACKING IN I-80 CONTROL SECTION



While evaluation of this procedure was not within the scope of this investigation, observations regarding this practice made as a part of the sawing and sealing investigation, suggest that improvements in this joint repair practice are needed.

In the first place, when this technique is applied prior to an overlay, and the overlay is not subsequently sawed and sealed over the end of the cut slabs, the later maintenance sealing effort will be doubled. An example illustrating this result is shown in Photos 62 and 63. These photos illustrate the appearance of an overlay constructed on South Broad Street (Route 206) in Trenton. On this project, as a result of the joint repair techniques, the number of transverse cracks at joints which had to be sealed was doubled from 19 to 38 in each city block.

Apart from putting undue strain on Maintenance forces in terms of the crack sealing effort, this joint repair technique can, in fact, destroy the integrity of the pavement. For example, on a project on Route 22 in Union, New Jersey, each concrete joint was cut out which reduced the pavement to a series of "floating" slabs. In such cases, increased pavement distress can be expected in the future. That is, when the joints are cut out, subsequent expansion of the remaining slabs can create a bump in the 4 foot bituminous patch at the joints. This bump will subsequently require heating and planing. Further, since the expanding slabs may not return to their original position, joints elsewhere on the project can open, permitting incompressibles to enter. Repeated cycles of expansion and contraction can thus cause failure at these other (untreated) joints.

Another significant problem with the conventional joint repair practice is that certain of the joints scheduled for repair, based on the condition of the overlay, may not in fact be distressed. In those cases, the joint repair operation



PHOTO 62
SOUTH BROAD STREET PROJECT
LONGITUDINAL AND TRANSVERSE REFLECTION CRACKING AFTER 7 YEARS SERVICE



PHOTO 63
REFLECTION CRACKING AT ENDS OF CONCRETE "REPAIR"

is obviously a needless expense. An example of this was recently encountered on the Route 10, Section 2G and 3G project. On that project, many joints were scheduled to be cut out and patched with bituminous mix based on the distressed appearance of the overlay (see Photo 64). In fact, after the overlay was milled off in the vicinity of the joint, the overlying concrete was found to be sound (Photo 65). While not all of the joints uncovered on this project were in as sound a condition, in some cases the concrete in the vicinity of the joint was only partially deteriorated (Photo 66). Hence, while the joint needed some patching prior to overlay, the practice of cutting out the slabs was not required.

The lesson to be learned from the foregoing is that prior to undertaking joint repairs, a "prospect" hole should be dug or cored to determine the extent of the damage to the joint to decide what the appropriate treatment is. The usual "eyeball" method of evaluating a tented joint generally presumes that the slabs are pressing against one another and are in imminent danger of creating a blowup. As illustrated in Photos 64 and 65, this is not the fact in all cases. Rather, the reason for the tenting is that incompressibles have entered the reflection crack in the bituminous overlay and on expansion of the slabs, the only place for the bituminous material to go is up, i.e., the stresses exerted by the hardened asphalt have caused delamination between the overlay and the underlying rigid pavement.

Based on the foregoing, it would appear that some follow-up investigation of our joint repair practices is in order. That work probably should encompass an evaluation of the feasibility of replacing the joint concrete in kind (i.e., new dowels, patching with quick-setting concrete).*

*The Department will, in fact, be evaluating the use of full-depth concrete patching with joints on the I-295 1X and 3F-5K projects. If the results obtained on these projects are favorable, the Department will consider broadening the use of this patching system including the use of rapid setting concrete.



PHOTO 64
ROUTE 10 PROJECT: APPEARANCE OF OVERLAY SURFACE



PHOTO 65
ROUTE 10 PROJECT: APPEARANCE OF UNDERLYING CONCRETE JOINT

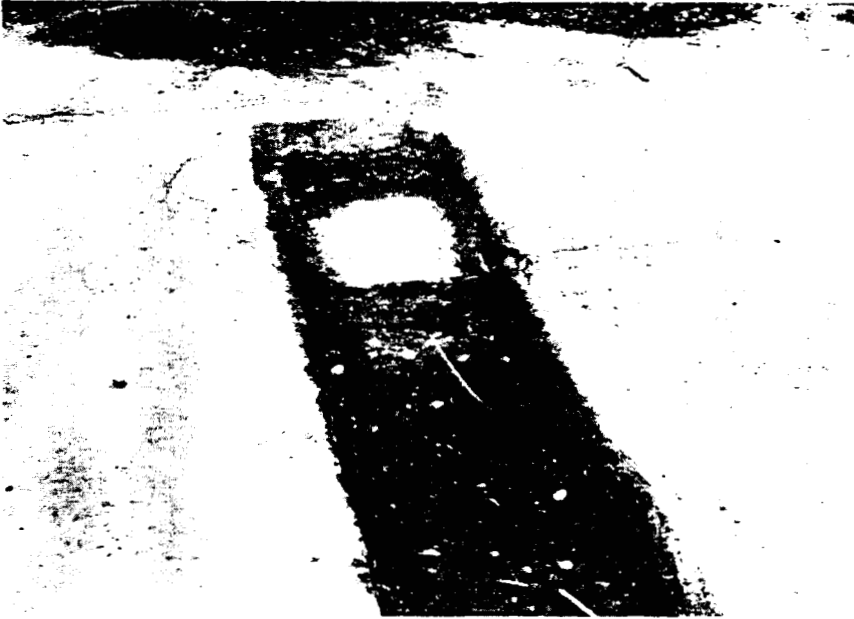

PHOTO 66

ROUTE 10 PROJECT: PARTIAL DECAY OF CONCRETE

SECTION VI

RESULTS AND CONCLUSIONS

1. Milling

The use of a cold milling machine to remove one or more courses of bituminous material is an effective method of pavement removal and provides the following benefits:

- a. permits resurfacing without the loss of overhead clearance.
- b. permits resurfacing without loss of curb reveal.
- c. permits the partial removal of a pavement, i.e., inlay method.
- d. corrects rutting and corrugations.
- e. generates feed stock for recycling.

As a result of this study, milling specifications and guidelines were developed for use by Department, county, and municipal engineers (see Appendix A).

2. Recycling of Asphaltic Concrete

The use of recycled asphalt pavement in the production of bituminous mixtures has proven to be a very cost-effective technique. Beginning with a 27,000 ton project evaluated in this study in 1978, the use of recycling in New Jersey has grown to an estimated 500,000 tons per year. This has afforded savings in construction costs on the order of \$1.50 - \$6.50 per ton depending on the total quantity of bituminous concrete on the project and the percentage of recycled pavement used. This research provided the necessary information to generate recycling specifications and guidelines (Appendix B).

3. Resetting Manholes and Inlets

An improved system for raising manholes and inlet heads based on the use of cast iron extension units has been developed and implemented. To provide ease of construction, this procedure relies on the use of a two-component epoxy to bond the extension unit to the old frame. A marked increase in field productivity has resulted, with associated savings in construction costs. Apart from increasing construction efficiency, the use of the new technique has reduced motorist delay time and discomfort. Problems encountered in resetting practice -- both with regard to the implementation of the new procedure and the use of the conventional (brick and mortar) practice -- have been resolved and documented in a set of Design/Construction guidelines (Appendix D).

4. Reflection Cracking

Based on the results obtained on an experimental test section constructed in this work, the weakened plane ("saw-and-seal") technique affords a positive means of preventing reflection cracks in bituminous overlays constructed over concrete pavements. After seven years' service, this experimental section has remained free of transverse and longitudinal cracking.

Beginning in 1984, based on the performance of the research test section and recent favorable results reported by others, the saw-and-seal procedure has been used by the Department on first generation overlays of concrete pavement. Based on the results of certain of these projects, a follow-up effort by Research will be required to insure that the saw-and-seal technique achieves its potential. Problems encountered on the first projects implementing the technique include a failure to saw the control joints in a timely manner, poorly referenced saw cuts, and poor sealing practices. A suggested specification for sawing and sealing is presented as Appendix F.

SECTION VII

FUTURE RESEARCH

1. Saw-and-Seal Technique

A follow-up research effort should be undertaken to improve the specifications/construction practices for the weakened plane system.

2. Sealing Existing Joints Prior to Overlay

Before the development of the saw-and-seal technique, the Department adopted a practice of cleaning out and resealing all joints on a concrete pavement prior to overlay regardless of their condition. This practice is expensive and can typically amount to \$100,000 or more per project.

On projects where the saw-and-seal technique is used, it is believed that this preliminary cleaning and sealing of all joints is unnecessary. Consequently, at the suggestion of Research, the quantity of cleaning/sealing has been markedly reduced on several projects, resulting in significant construction economies. Research should continue its ongoing dialogue with Design to determine under what conditions cleaning and sealing is required. (Portions of a forthcoming Route I-80 project have tentatively been set up to provide a further evaluation of this point.)

REFERENCES

1. Gray, B. E. and Martin, G. E., "Resurfacing of Concrete Pavements with Bituminous Types of Surface", Vol. 12, HRB Proceedings (1932), pp. 177-192.
2. Hensley, M. J., "Stopping Reflection Cracking", Asphalt Quarterly, July 1973.
3. Croteau, Jack, "Pavement Roughness Evaluation Using a Mays Ride Meter", FHWA/NJ-82/003, June 1981.
4. David, Lewis R., "Production Efficiency Study on Pavement Planing Equipment", Interim Report No. FHWA-DP-PC-1000-1, March 1979.
5. Sommerfeld, Jeffrey C., "Production Efficiency Study on Pavement Planing Equipment", Final Report No. FHWA-DP-DC-1000-2, December 1981.
6. Cohen, Alexander; Anticaglia, Joseph R.; and Jones, Herbert H.; "Noise Induced Hearing Loss-Exposure to Steady State Noise", Sixth Congress on Environmental Health, Chicago, IL, April 28-29, 1969.
7. Hellriegel, E. J., "Recycling Asphalt Pavements, North Brunswick, NJ", Demonstration Projects Program Technology Transfer, FHWA-DP-38-29, August 1980.
8. Bone, A. J., Crump, L. W., and Roggeveen, V. J., "Control of Reflection Cracking in Bituminous Resurfacing Over Old Cement Concrete Pavement", Proceedings, 33rd Annual Meeting, Highway Research Board, January, 1954.
9. Tons, E., and Roggeveen, V. J., "Laboratory Testing of Materials for Sealing Cracks in Bituminous Concrete Pavements", Highway Research Abstract 25:19 (September, 1955).
10. Tons, E., "A Theoretical Approach to Design of a Road Joint Seal", HRB Bulletin 229, 20-53 (1959).
11. Wilson, John, "Crack Control Joints in Bituminous Overlays on Rigid Pavements", HRB Bulletin 322, 21-29 (1963).
12. Memo from J. Freidenrich, State Highway Engineer, New Jersey Department of Transportation to J. Kessler, FHWA Division Administrator, May 9, 1986.

A P P E N D I X A

THE FOLLOWING IS ADDED TO THIS SECTION:

MILLING OF BITUMINOUS CONCRETE

DESCRIPTION.

MILLING OF BITUMINOUS CONCRETE SHALL CONSIST OF THE REMOVAL OF BITUMINOUS CONCRETE SURFACE AND BASE COURSE TO THE PRESCRIBED DEPTH, PROFILE AND CROSS SLOPE.

EQUIPMENT.

THE MILLING MACHINE SHALL BE A SELF-PROPELLED PLANING, GRINDING OR CUTTING MACHINE WITH VARIABLE OPERATING SPEEDS, CAPABLE OF REMOVING BITUMINOUS CONCRETE WITHOUT THE USE OF HEAT.

THE MILLING MACHINE SHALL BE EQUIPPED WITH AUTOMATIC GRADE CONTROLS. THE REFERENCE SYSTEM MAY BE EITHER STRINGLINE OR SKI TYPE. USE OF THE AUTOMATIC GRADE CONTROLS WILL BE REQUIRED EXCEPT AT INTERSECTIONS AND OTHER LOCATIONS WHERE IT IS NOT PRACTICAL.

TEETH IN THE MILLING DRUM THAT BECOME DISLODGED, BROKEN OR UNEVENLY WORN SHALL BE REPLACED IMMEDIATELY WITH TEETH OF THE SAME LENGTH AS THE REMAINING TEETH IN THAT ROW.

CONSTRUCTION REQUIREMENTS.

A TEST STRIP OF APPROXIMATELY 500 SQUARE YARDS SHALL BE CONSTRUCTED WITHIN THE PROPOSED LIMITS OF MILLING PRIOR TO COMMENCEMENT OF THE MILLING OPERATIONS. THE TEST STRIP SHALL BE USED TO DETERMINE THE MACHINE AND DRUM SPEEDS OF OPERATION WHICH WILL PRODUCE THE PROPER SURFACE TEXTURE AND WHEN PROFILE MILLING IS CALLED FOR, TO DETERMINE THE CUTTING DEPTH REQUIRED TO REMOVE RUTS AND TRANSVERSE CORRUGATIONS.

THE MILLING OPERATION MAY BEGIN WHEN THE ABOVE CRITERIA HAVE BEEN ESTABLISHED AND APPROVED. THE MACHINE SHALL BE OPERATED AT THE SPEEDS AND CUTTING DEPTH DETERMINED DURING THE TEST STRIP MILLING. TEST STRIPS SHALL BE CONSTRUCTED FOR EACH MILLING MACHINE USED. IF THE AREA TO BE MILLED IS LESS THAN 2500 SQUARE YARDS, A TEST STRIP MAY NOT BE REQUIRED.

THE MILLING OPERATION, INCLUDING REMOVAL OF THE MILLED MATERIAL, SHALL BE CARRIED OUT IN A MANNER THAT WILL PREVENT DUST AND OTHER PARTICULATE MATTER FROM ESCAPING INTO THE AIR.

IF THE MILLED MATERIAL IS TO BE RECYCLED, THE MILLING EQUIPMENT, WHERE PRACTICAL, SHALL BE OPERATED IN SUCH A MANNER AS TO PRODUCE MILLED MATERIAL OF WHICH 95 PERCENT WILL PASS A 2 1/2 INCH SIEVE.

IF THE MILLED MATERIAL IS TO BE RECYCLED, THE AREA OF MILLING SHALL BE CLEARED OF ALL DEBRIS AND POWER BROOMED TO REMOVE FINE

MAY 31, 1984

PARTICLES PRIOR TO MILLING. BEFORE BROOMING, EARTH BERMS SHALL BE REMOVED, AS NECESSARY, WITHIN THE AREA TO BE MILLED TO PREVENT SOIL AND GRASS FROM CONTAMINATING THE MILLED MATERIAL. DISPOSAL OF EARTH AND DEBRIS SHALL BE IN ACCORDANCE WITH SUBSECTION 202.11.

PROVISIONS SHALL BE MADE FOR REMOVAL OF ANY WATER THAT MAY BE TRAPPED DUE TO THE MILLING OPERATION, SUCH AS BY LATERAL SAW CUTS INTO THE ADJOINING LANE OR SHOULDER AREA. IN THE EVENT THAT ALL MILLED AREAS WHICH ARE OPENED TO TRAFFIC HAVE NOT BEEN MILLED TO A FLUSH SURFACE BY THE END OF THE WORK DAY, THE LONGITUDINAL EDGES OF THE MILLED AREA, EXCEEDING 1 1/2 INCHES HIGH, SHALL BE SLOPED AND A SMOOTH TRANSITION SHALL BE PROVIDED AT THE TRANSVERSE EDGES.

AREAS TO BE MILLED NOT ACCESSIBLE TO THE MILLING MACHINE SHALL BE REMOVED BY OTHER EQUIPMENT.

BITUMINOUS CONCRETE BELOW THE SPECIFIED LEVEL OF MILLING THAT BECOMES DISLODGED OR DELAMINATED SHALL BE REMOVED AND REPLACED WITH BITUMINOUS CONCRETE IN ACCORDANCE WITH SECTION 404 WITHOUT ADDITIONAL COMPENSATION.

THE SURFACE OF THE MILLED AREA SHALL BE SWEEPED CLEAN PRIOR TO BEING OPENED TO TRAFFIC AND PRIOR TO THE FOLLOWING CONSTRUCTION OR RESURFACING STAGE. SWEEPINGS SHALL BE DISPOSED OF IN ACCORDANCE WITH SUBSECTION 202.11.

THE MILLED AREA THAT WILL BE OPENED TO TRAFFIC BEFORE RESURFACING SHALL BE FREE FROM GOUGES, CONTINUOUS GROOVES, RIDGES AND DELAMINATED AREAS AND SHALL HAVE A UNIFORMLY TEXTURED APPEARANCE CONSISTING OF DISCONTINUOUS LONGITUDINAL STRIATIONS WHICH SHALL NOT DEVIATE MORE THAN 1 INCH IN 200 FEET FROM A LINE PARALLEL TO THE CENTER OF THE TRAVELLED WAY AND SHALL NOT EXCEED 3/8 INCH DEPTH AND WHICH SHALL PROVIDE A SKID RESISTANCE NOT LESS THAN THAT OF THE ORIGINAL SURFACE PRIOR TO MILLING AND SHALL PERMIT PASSAGE OF TRAFFIC AT THE POSTED SPEED LIMIT WITHOUT VEHICLE OPERATORS EXPERIENCING IMPAIRED DIRECTIONAL CONTROL.

METHOD OF MEASUREMENT.

MILLING WILL BE MEASURED BY THE SQUARE YARD.

THE DEPTH OF THE COMPLETED MILLING WHEN MEASURED FROM THE ORIGINAL SURFACE TO THE TOP OF THE HIGH SPOTS OF THE TEXTURED SURFACE SHALL BE EQUAL TO THE PRESCRIBED DEPTH OF CUT EXCEPT FOR PROFILE MILLING FOR WHICH THE DEPTH OF CUT SHALL BE ONLY THAT NECESSARY TO REMOVE THE BITUMINOUS CONCRETE ABOVE THE BOTTOM OF WHEELPATH RUTS AND TRANSVERSE CORRUGATIONS WHILE PRODUCING A SMOOTH PROFILE AND CROSS SECTION.

BASIS OF PAYMENT.

PAYMENT WILL BE MADE UNDER:

MAY 31, 1984

<u>PAY ITEM</u>	<u>PAY UNIT</u>
MILLING, " DEPTH	SQUARE YARD
MILLING, " AVERAGE DEPTH	SQUARE YARD
MILLING, VARIABLE DEPTH	SQUARE YARD
PROFILE MILLING	SQUARE YARD

***** (END) *****

H
H

A P P E N D I X B



IN REPLY PLEASE REFER TO

Guidelines for
Pavement Recycling

State of New Jersey
DEPARTMENT OF TRANSPORTATION

1035 PARKWAY AVENUE
CN 800
TRENTON, NEW JERSEY 08625

JOHN P. SHERIDAN JR.
COMMISSIONER

March 1, 1983

MEMORANDUM

All Design Units

The attached guidelines for the recycling of existing bituminous pavement, which was prepared by the Bureau of Transportation Structures Research and distributed to municipal and county engineers, is transmitted for guidance in the preparation of Plans and Specifications.

Several pages have been revised in this issue in order to make it more consistent with present day concepts.

Memorandums will be issued which will provide additional guidance for the use of 20 to 50 percent of reclaimed asphalt pavement (RAP) and for methods of removing bituminous concrete.

Kenneth C. Afferton
Chief Engineer, Design

CT:ki
Attachment

1.0 INTRODUCTION

The recycling of pavement materials has been used for many years in a limited manner. In the past decade, however, the tremendous increase in crude oil prices has made this once novel concept almost mandatory for the rehabilitation of pavements.

This treatise is a compilation of New Jersey's experience in recycling and excerpts from the "Proceedings of the National Seminar on Asphalt Pavement Recycling"⁽¹⁾ and NCHRP Report 224⁽²⁾ and is intended to serve mainly as a guide for NJDOT staff on the use of hot-mix recycling. Memorandum to All Design Units dated August 6, 1982 included guidelines and specifications for the use of 10% reclaimed asphalt pavement (RAP). Guidelines and specifications for the use of 20 to 50% RAP will be issued soon. They will limit the use of 20 to 50% RAP to those projects where the RAP is obtained from a NJDOT pavement. This restriction is necessary as there is presently no other practical way of assuring that the reclaimed pavement material is of consistently good quality. In effect, this results in only using 20-50% RAP in a closed system approach--material to be recycled comes from the pavement being rehabilitated. It is theoretically possible to coordinate projects so that pavement material removed from one project could be recycled for use on another. However, experience has shown that this is usually not feasible from a cost standpoint.

2.0 BACKGROUND

Federal, state and local agencies are faced with many new problems hindering the construction, maintenance and rehabilitation of transportation facilities. Significant among these problems are:

Footnotes:

- (1) "Proceedings of the National Seminar on Asphalt Pavement Recycling", Amfac Hotel and Resort, Dallas-Ft. Worth, Texas, October 14-16, 1980.
- (2) "Guidelines for Recycling Asphalt Pavements", NCHRP Report 224, Research Agency Texas A&M, Completed 9/30/79.

1. A reduction in available funds caused by inflation, reduction in revenue from fuel tax, and increased staff salaries.
2. Material supply problems due to depletion of sources near the point of use, material unavailability due to zoning laws which restrict quarry operations, increased haul distances with associated transportation costs, and strict environmental codes requiring major expenditures for air and water quality as well as noise control.
3. Equipment availability problems resulting from reduced budgets, high cost of new equipment and manpower problems resulting from fiscal constraints.
4. Energy problems associated with fuel costs, availability and the attendant necessity to reduce energy consumption.

Because of these and other problems the need to optimize the use of available aggregates, binder materials, energy and funds is more critical now than at any other time in the recent past.

One solution to some of the problems outlined is to recycle existing materials. Recycling of bituminous pavements offers several advantages over the use of conventional materials. Among the major benefits are the conservation of aggregates, asphalt binders, and energy. It can also aid in preservation of the environment and existing highway geometrics.

Aggregate conservation is important. Although New Jersey has an abundant source of supply for the foreseeable future, it is not always in the location of need (southern New Jersey, for example), thus it has become necessary to haul aggregates long distances escalating the cost and energy consumed in resurfacing and rehabilitating roadways.

Conservation of asphalt binders is another important advantage of recycling. Reuse of the bituminous concrete can save about five gallons

of asphalt per ton, thus contributing to the national fuel conservation program.

When one considers the lesser quantities of aggregate, the asphalt cement, and the inherent energy necessary in the production and transportation of these materials, energy conservation could be of significant magnitude. In the past this figure would only be of interest to the academician but now becomes a key input to the pricing of a contract item.

Recycling also contributes to the preservation of the environment by reducing the amount of new material required. Thus, a reduction in environmental degradation is possible in the mining and production of the product, as well as, in the disposition of the old pavement.

Highway geometrics maintenance can easily be achieved by recycling. Vertical clearance problems caused by overlays at bridges, signs, and tunnels can be overcome by strengthening the base or subgrade. Vertical control problems with drainage facilities, such as curb height, gutter flow lines, and inlet and manhole elevations, are reduced when recycling is used in place of overlays.

On many projects the total cost is the primary consideration in determining the method of rehabilitation to be selected. For recycling to be selected it must usually be the least expensive of the alternate methods. Since recycling is a relatively new technique to some, contractor bid prices have been higher than expected. These prices have been inflated by the fact that the contractor tried to recapture the plant modification cost immediately. As recycling becomes a standard procedure, contractors will be more apt to write off the capital expenditure for the plant modifications over several projects or competition will

force them to do so. It will probably be several years before the true cost of recycling is realized and the actual cost accurately determined. Various reports show savings from \$0.98 - \$6.10 per ton of recycled mix. Florida showed a 25% reduction in mixture costs, while Minnesota found a 35% saving between the contractor's bid price for the hot-mix recycled portion of the project and the engineer's estimate based on conventional construction.

Because recycling appeared to be an attractive alternative for pavement rehabilitation, much more modern technology was, and is being developed to make recycling almost mandatory. The available technology as implemented in the state of New Jersey is described herein and provides the basis for proposed guidelines for pavement recycling.

3.0 SELECTION OF RECYCLING ALTERNATIVES

In order to select the most appropriate recycling alternate for a particular project, the conditions of the existing facility should be fully described and investigated. Key factors such as (1) surface condition, (2) structural conditions, (3) roughness, and (4) skid resistance, along with traffic data and available funding will enter into the selection process. These factors along with a summary of key data to be considered are discussed as follows:

3.1 EXISTING FACILITY

Specific items such as (1) the size and location of the project, (2) roadway class, (3) existing pavement cross section, (4) geometrics,

(5) subgrade characteristics, and (6) traffic all play a part in the recycling selection process.

3.1.1 Size and Location of Project

A producer would have to process about 5000 tons of RAP through a batch plant at a 50/50 ratio to recoup the plant modification cost. Therefore, on projects that involve the use of at least 5000 tons of RAP, the producer can recoup the plant modification costs on that one project and provide bituminous concrete at the same price as all virgin material. As an inducement to encourage more producers to convert their plant, the NJDOT is permitting a 10% substitution of salvaged bituminous material in lieu of virgin material in all paving mixtures except the top layer of the surface course in the travelled way. As conversions are made, the size and location of the job will become immaterial.

The location of the project with respect to hot-mix plants and their aggregate sources will eventually have a significant effect on the cost of a recycled mixture. If plant haul distances to aggregate (and asphalt) sources far exceed haul distances from a project to the hot-mix plant, recycled mixtures should be appreciably less costly to produce than a virgin mixture. This particular haul distance condition seems to be most applicable to asphalt plants in the southern third of New Jersey where coarse aggregates are predominantly imported from Pennsylvania. Lower costs for recycled mixture (relative to virgin mix) are also likely if the rehabilitation project is located

near a plant that is already modified for hot recycling. In those instances where location favors the preceding cost conditions, alternate bidding for recycled and new mix should result in recycled mix being bid at lower unit prices.

3.1.2 Roadway Class

Generally the roadways can be classed in broad categories as Interstate and Urban Freeway, Rural Primary (U.S. and state signed routes), Rural Secondary (farm-to-market, park roads, etc.) and Urban Streets (arterial, collector, local). Interstate and Urban Freeway rehabilitation would usually be an overlay after correcting localized base problems or surface unevenness. The most likely recycling technique is to remove all or part of the old pavement depending on whether it was a composite or bituminous pavement and reuse the removed material as a portion of the new hot mix applied as a base or bottom layer of surface course. Rural Primary rehabilitation would usually be through surface recycling with milled material hot mixed at a central plant with new aggregate and asphalt cement and placed as a base or bottom layer. Rural Secondary often consists of reworking the total pavement and base into a new base capped with a surface treatment or surface course. Pulverization with in-place mixing of a stabilizing agent such as lime, cement, lime-fly ash or emulsified asphalt can result in significant cost and energy savings. However, specific recommendations for this class of roadway must be deferred until a successful series of field trials have been made on NJDOT projects.

Urban streets are the most likely candidates for surface milling with recycling as a base or bottom layer if structural improvement is required. An alternative for this class of roadway is to remove and stockpile old surface material for use elsewhere as part of a base or bottom layer. The savings in energy and costs in this situation may or may not be in the initial project but are realized by salvaging the economic value of the removed material on another project.

3.1.3 Existing Pavement Cross-Section

Old pavements on state projects usually have had the benefit of quality controlled materials placed under state inspectors. Data from the original construction with a listing of the thicknesses and types of material are usually available. Subsequent history of maintenance activities such as overlays, seal coats, patching, and crack sealing may influence the selection of a recycling alternative. In order to make a valid determination and ascertain the validity of the history and the nature of existing material, a coring schedule commensurate with the size of the project should be planned. The more information gathered about the materials and construction background, in conjunction with the proper testing, evaluation, planning and design will avoid surprises at the time of construction.

3.1.4 Geometrics

The geometric features such as the horizontal and vertical alignment are often constraints to rehabilitation of the roadway by the addition of a bituminous overlay. Normally the overlay in the driven way is constructed at a given thickness and tapered to near zero to preserve the

gutter line on curb face. Multiple overlays thus result in excessively high crowns, steep cross-slopes and ultimate loss of curb reveal. Recycling utilizing milling techniques can be cost-effective in resolving these problems, as well as alleviating the necessity of adjusting roadway hardware such as manhole and inlet frames. Recycling can also be a boon to maintaining the vertical clearance of overhead structures.

3.1.5 Subbase Characteristics

Failure of the pavement/shoulder layers due to saturation may call for removal of the subbase or the construction of drains to improve the condition. Recycling of the removed pavement layers by central plant hot-mix or in-place cold mix could be a cost-effective alternative. As previously described under Article 3.1.2 Rural Secondary, the state has not rehabilitated any mainline pavement by the cold mix-in-place method to improve a base, subbase, or subgrade. Since most of the stabilizing agents are slow curing, it would be advisable to select as a test site either an institutional road or parking space or a low volume roadway of less than 2000 vehicles per day with little or no truck traffic. For the present, only shoulder rehabilitation as shown in 3.6 and 4.4 is recommended.

3.1.6 Traffic Characteristics

The speed and volume of traffic to a large extent determines the traffic control problem associated with pavement rehabilitation activities. The use of recycling on high traffic volume urban facilities should be geared toward activities that can provide low roadway occupancy time,

can be performed with single lane blockage, and can use materials with rapid strength gain after placement.

3.2 SURFACE CONDITION

Each project should be surveyed for the surface defects that can be used to access the cause of distress and suggest the corrective action. The materials comprising the distressed pavement, i.e., portland cement concrete, composite pavement, or bituminous section could dictate the selection of an appropriate recycling alternative.

3.3 STRUCTURAL CONDITION

An inadequate pavement structure can be corrected by increasing the thickness of the major load-carrying layers of a portland cement concrete, composite, or bituminous pavement. A decision on whether or not a structural upgrading of a deteriorated pavement is needed and how it is to be accomplished must be made by an experienced pavement designer. In the NJDOT this decision should be vested in staff of the Bureau of Geotechnical Engineering.

The range of alternative recycling procedures offered can be used to correct any deficiency that can be corrected by the use of new materials. There is some concern regarding the use of recycled materials for the surface course of mainline pavement in that these materials have been found in other states to be somewhat stiffer than new mixtures. The added stiffness could equate to premature surface cracking. Until experience dictates otherwise the use of recycled material in the top layer of the surface course is being withheld.

3.4 ROUGHNESS

The roughness of ride in some instances may be the deciding factor for the rehabilitation of a roadway. Surface milling is an excellent means for correcting this type of distress and can be used in conjunction with thin resurfacings or as an alternate to resurfacing.

The area for some 200 ft. preceding a stop line is typically characterized by surface distortion, slippage, and roughness distress with bituminous surfaces. Normally this situation could be remedied by milling of the surface course with a replacement overlay as a spot improvement. If the pavement is rough and has other deficiencies such as rutting, shoving, alligatoring, or requires more extensive rehabilitation, the roughness will be probably taken care of automatically in removing the other deficiencies.

3.5 SKID RESISTANCE

Pavements may perform adequately from a structural standpoint but show a loss of skid resistance due to polishing of the aggregate, excess asphalt, low void content or bleeding of the tack coat. All of these conditions could potentially be alleviated by recycling if and when the Department permits the use of recycled material in the top layer of the surface course. However, in the case of aggregate problems, blending with good polish-resistant aggregate may only provide marginal improvement in skid resistance unless the polish-resistant aggregate constitutes 70% or more of the coarse aggregate component.

3.6 RECYCLING OTHER THAN HOT-MIX

One means for improving the structural strength of a distressed pavement is to stabilize and, hence, strengthen the unbound soil aggregate (base and subbase) layers. A stone base when stabilized by mixed in-place means has a distinct cost and energy advantage. The Department has project-tested two materials for stabilization, soil-cement and lime-fly ash which unfortunately displayed a great disadvantage when spread pneumatically from a tanker truck. The clouds of dust generated due to the fineness of the material preclude its use in urban areas, and in rural areas may necessitate temporarily stopping traffic for safety reasons. The soil-cement process would only be recommended for stabilization in new construction in rural areas, due to the aforementioned problem. Lime-fly ash, however, can be used anywhere for in-place stabilization by removing approximately 1/3 of the base material for central plant mixing. All of the lime and fly ash necessary to stabilize the total thickness should then be added to the stone making an extremely enriched mix. The water content should be increased (8-10%) to accommodate the increased surface area of extra addition of the lime and fly ash. The finished mix is then returned to the job site and spread by either a paver or tailgated by truck and bladed with a grader. The enriched LFA bound material is mixed with the remaining aggregate base and checked for moisture content. Additional water if required is added and remixed to the specified thickness. This method completely alleviates the dust problem and provides a good product at a modest increase in cost. It may be desirable to require this particular method by specification when moderate to high traffic volumes are involved.

4.0 GUIDELINES FOR RECYCLING ASPHALT PAVEMENT MATERIALS

There are twenty-four recycling alternatives outlined in NCERP Report 224 "Guidelines for Recycling Pavement Materials" some of which are not appropriate for the state of New Jersey, some for which we have no experience, and others which are planned for the future. Based on successful applications to date, eight alternatives are recommended at this time. These alternatives are described below. New alternatives will be added after successful field trials are demonstrated.

4.1 SURFACE MILLING PLUS THIN OVERLAY (MI)

This operation involves the removal of the pavement surface by a cold milling machine. The depth of removal is variable and may be as great as 2" in a single pass with the material removed from the site. The material when salvaged as a recycled hot mix would be processed thru either a batch or drum mix plant. An example would be the removal of the surface course that is delaminated, corrugated, rutted or exhibits a loss of frictional properties on either a bituminous section or an overlay on portland cement concrete. The milled material could be recycled as a base, bottom layer of surface course in the travelled way or shoulder courses on the same project. It could also be employed as a base, bottom layer of the surface course in the travelled way, or shoulder courses on a nearby project. Preferably, the projects should be combined. If neither option is available then the material should become the property of the contractor. The value of the milled material will be reflected in lower bid prices on other items.

4.2 SURFACE MILLING PLUS THICK OVERLAY (M2)

This operation would involve the removal of the pavement to a depth of 3"-5" by a cold milling machine in one or two passes with the milled material removed from the site and placed in single or multiple stockpiles depending on the tonnage and mixes to be placed. For example, if a shoulder course is to be placed it would be easy to meet the gradation by having the top layer of the surface course milled and stockpiled separately. The second milling would normally be of coarser gradation and could be used for base and/or bottom layer mixes. In the case of a "widening" where perhaps 9" of base would be required, the contractor may elect to remove the required thickness in one pass blending the surface and base material with the milling process and maintain a single stockpile. By adjusting the ratio of salvaged to new material the contractor could supply the entire base course with a recycled mix; and any overage of salvaged milled material could be used to produce a bottom layer mix. If structural improvement is required, the contractor could elect to recycle the milled material in a base or bottom layer of the surface course and use all new materials in the top layer at the surface and/or shoulder course.

The designer should allow enough flexibility through the use of alternates to permit the contractor to use the salvaged pavement in the manner most economical to him in order to arrive at the best price.

4.3 PAVEMENT REMOVAL OVER PCC PAVEMENTS (P1)

If a 3"-5" bituminous pavement is to be removed to the depth of the underlying portland cement concrete, the removal could be accomplished by cold milling. However, an alternate method of removal would be by

ripping, transporting to a stockpile with subsequent crushing prior to recycling. There is a slight advantage to the latter method for a batch plant that is equipped for recycling since the larger blocks when stockpiled tend to absorb less moisture and have a greater tendency for drainage. Less moisture means less energy (fuel) required in the recycling process. Furthermore, when ripping and crushing are included as an alternate method, it may have a positive effect on the bid prices.

4.4 PAVEMENT REMOVAL ON SHOULDERS (S1)

The method of shoulder rehabilitation will depend on several factors:

- 1) Is the mainline pavement PCC composite or bituminous?
- 2) Is the mainline pavement recommended for overlay?
- 3) What are the constituents of the shoulder surface?
- 4) What are the constituents of the base and subbase?
- 5) Is the pavement pumping?

The various combinations of the above could produce any number of options, for example:

1a. The distressed shoulder is adjacent to a PCC pavement, the shoulder is a standard 1½ or 2" bituminous surface course on a stone base, and the mainline pavement is not to be overlaid.

ACTION: Mill the shoulder surface course, excavate approximately 1½-2" and roll to grade, recycle the bituminous material and place as 2" base course and 1½" shoulder course. If the area is pumping and drainage is not planned, the stone base should be stabilized with lime-fly ash or cement to a depth of 7" and surfaced with 2" of recycled shoulder course. (The suggested thicknesses should be adequate for most

interstate and primary route upgradings. However, project specific values could be obtained by assuming the shoulder will incur 10% of the mainline traffic and then undertake a pavement thickness design.)

1b. The shoulder is adjacent to a PCC mainline pavement which is to be overlaid.

ACTION: Normally the distressed areas of shoulder would be patched and 1½" binder course placed over the mainline and shoulder, followed by a surface and shoulder course. If the distressed area exceeds over 30%, surface removal and recycling should be considered since there is usually further deterioration between the time the field survey is made and implementation of the contract. The salvaged milled material can be placed as a recycled bottom layer surface course in the distressed area with the overage material used as a recycled bottom layer surface course for the mainline overlay.

1c. The shoulder is adjacent to a composite pavement.

ACTION: The conditions and method of solution can be selected from M1, M2 or P1.

1d. The shoulder is adjacent to a bituminous pavement.

ACTION: The conditions and method of solution can be selected from M1, M2 or S1b.

5.0 PAVEMENT THICKNESS DESIGN FOR RECYCLED MIXTURES

Structural design associated with surface recycling is limited to the thickness of overlay required to prevent failure due to traffic and reflection cracking. The AASHTO and the layered elastic design procedures are the primary methods of structural design because these methods are

Revised MARCH 1983

the most flexible in terms of materials layer strength characterization. Layer strength coefficients for recycled material have been determined in the field and through laboratory investigations. The majority of the results showed them to be approximately equal to conventional layers. The coefficients used for design in New Jersey are:

Bituminous surface course.....	0.44
Bituminous stabilized stone base.....	0.44
Bituminous Stabilized gravel base.....	0.34
Lime-fly ash stabilized base.....	0.30
Soil cement stabilized base.....	0.30
Reinforced concrete surface course.....	0.55

6.0 SPECIFICATIONS FOR RECYCLED MIXTURES AND MILLING

Memorandum to All Design Units dated August 6, 1982 included specifications for the use of 10% RAP.

Specifications for the use of 20 to 50% RAP and milling will be issued soon. A general description of their content is provided below.

6.1 20-50% RAP

Quality control of construction is important whether it be for all new construction or recycling. Because of the non-uniformity of salvaged materials from multiple sources, the reclaimed asphalt pavement (RAP) material described in the specification will be from the material salvaged from the pavement to be rehabilitated, i.e., that is a closed system. The various subsections describing size of material, method of stock-piling and equipment are the results of successful field tested projects. Data on the composition of cores obtained from the bituminous pavements

to be salvaged will be provided by the Bureau of Quality Control. This data can be helpful in judging the composition of the salvaged material and the percentage to be used in the recycled mixture.

6.2 MILLING

The milling specifications have been written in conjunction with representatives of the contracting industry. Description of the finished milled surface and the texture produced for trafficked areas has been described in detail. A test strip for the milling operations has been included to establish those criteria necessary to meet the required specification prior to start of the production milling. The criteria established in the test strip operation should prevent any misinterpretation between the engineer and the contractor.

7.0 FLOW CHART FOR DECISION ON RECYCLING

A flow chart showing the preliminary information, field testing (cores) and the laboratory data necessary to evaluate the pavement for determining the method of rehabilitation is presented in Figure 1. For NJDOT projects this figure also indicates the various areas of responsibility for the involved department units and the contribution of each unit to the overall process. A comparison of the recycling alternatives versus conventional rehabilitation will be required for projects where federal funding is involved.

FIGURE 1

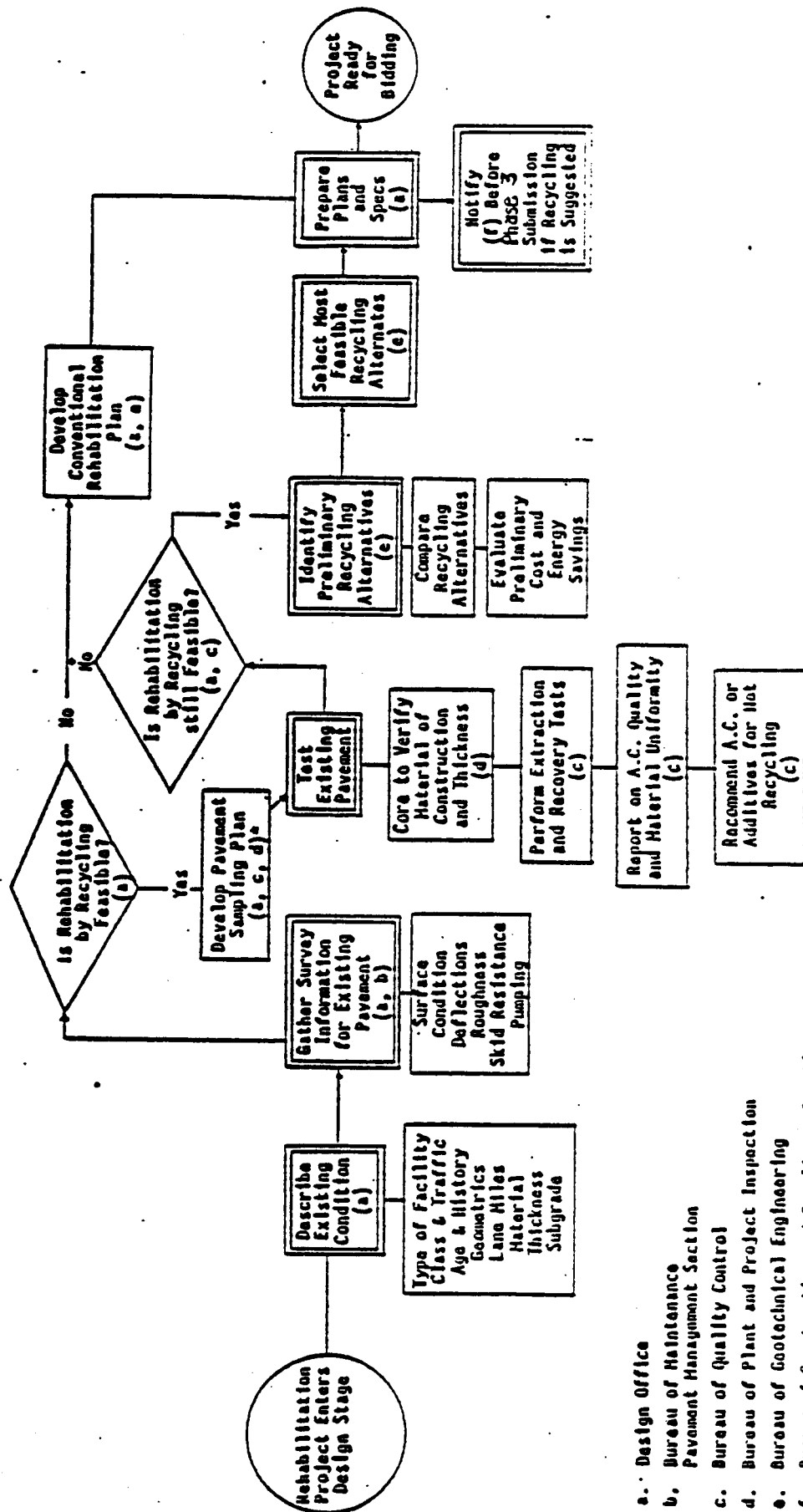

- a. Design Office
- b. Bureau of Maintenance Pavement Management Section
- c. Bureau of Quality Control
- d. Bureau of Plant and Project Inspection
- e. Bureau of Geotechnical Engineering
- f. Bureau of Construction and Compliance Practices

*Minimum of two samples for each identifiable pavement material source.

FIGURE 1

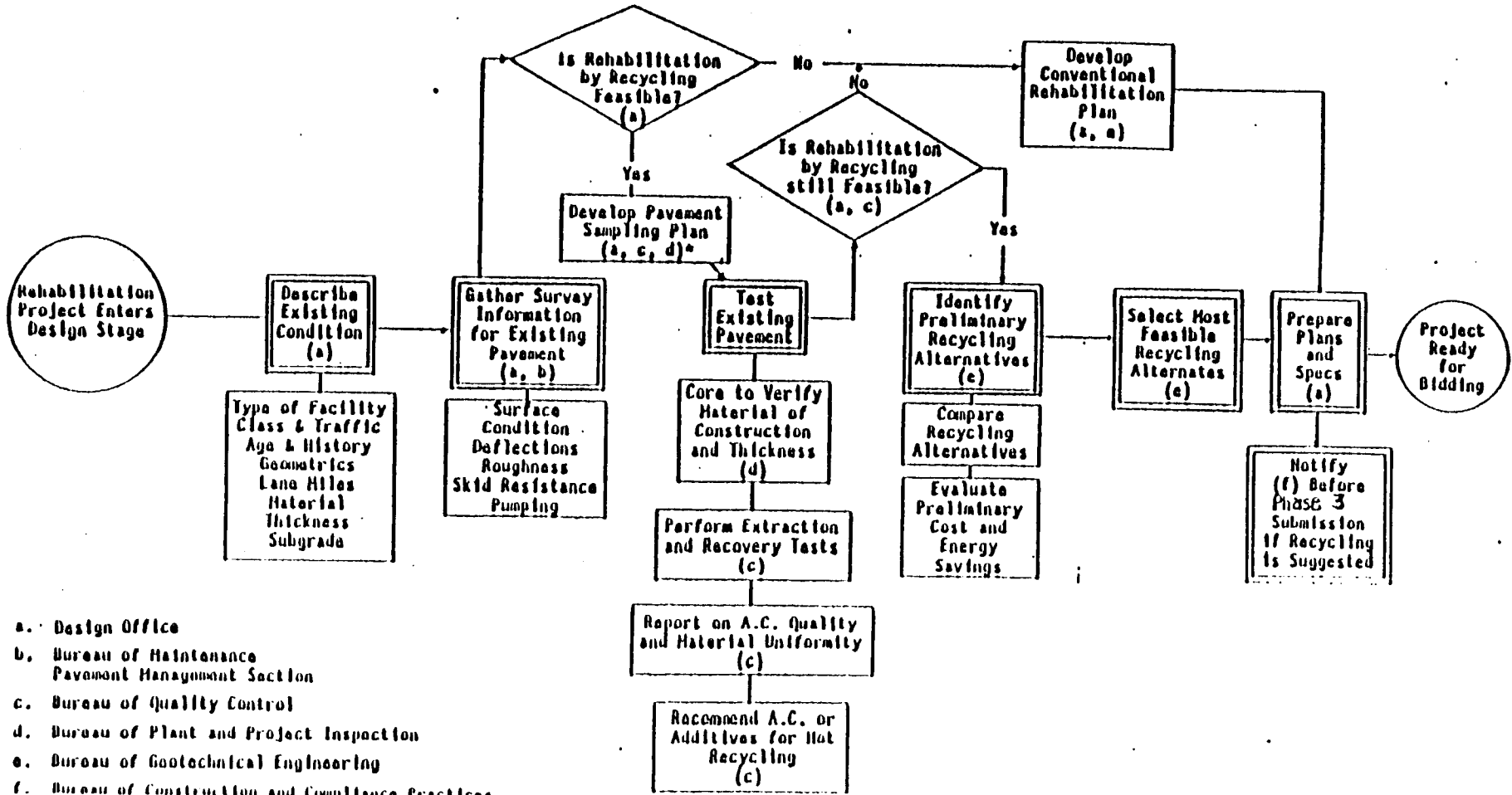

*Minimum of two samples for each identifiable pavement material source.

APPENDIX C

The following is added to this section of the standard specifications:

CAST IRON EXTENSION FRAMES FOR EXISTING INLETS

CAST IRON EXTENSION RINGS FOR EXISTING MANHOLES

DESCRIPTION

At locations shown on the plans, existing inlet grates and manholes shall be raised to the prescribed finished grades by means of cast iron extension frames and rings conforming to the respective details therefor shown on the plans.

The cast iron extension frames and rings shall be of such dimensions as to fit the existing castings and receive the existing or new grates and covers to the satisfaction of the engineer. The contractor shall verify all dimensions before ordering the new castings.

MATERIALS

Cast iron shall be gray iron conforming to ASTM A48-70 Class 30 specifications.

The epoxy bonding and bedding compound shall conform to the following:

1. GENERAL

1.01 This specification contains the engineering requirements for a two part, non-sag gel, rapid setting epoxy adhesive in a plastic mixing and dispensing device for bonding cast iron extension devices to inlet and manhole frames when the road grade level is being raised for resurfacing. A product such as Riser Gel by Preco Industries Ltd. of Plainview, New York or equal will be acceptable. The supplier must show two years of successful field application or have an approved testing agency authenticate that the material meets the following specifications.

2. DESCRIPTION

2.01 The cast iron extension frame bonding kit is a unit container of adhesive designed to separate the resin base and the curing agent until blending is required, allow mixing of the preproportioned components within the container and then dispensing from the container via an applicator gun.

2.02 The bonding kit shall be used in the following ambient temperature range:

40 - 100 Deg. F

2.03 The bonding kit is available in one size (10½ Oz.) for bonding an individual extension device up to 42 inches in diameter.

3. REQUIREMENTS

3.01 Where reference is made to an ASTM designation in this specification, the issue listed in the latest published ASTM index to standards shall apply unless otherwise specified. The test bars will be prepared as per ASTM D2651 Method A.

3.02 The adhesive kit shall consist of a 10½ ounce polyethylene barrier type mixer/applicator cartridge containing an approved 2 part adhesive system with a plastic nozzle for dispensing the epoxy after blending.

PROPERTIES

3.03 DENSITY: The density of the individual parts shall be specified below:

Part A 9.40 ± 0.30 lbs./gal.

Part B 9.30 ± 0.30 lbs./gal.

3.04 VISCOSITY: The viscosity of the individual parts and the 1 to 1 by volume mix shall be specified below:

Part A 120 to 140 KU

Part B 130 KU to short paste (Gel)

Mixed, 1 to 1 (by volume) short paste (Gel)

3.04a NON-SAG: A 1 inch wide, 6 inch long, ¼ inch thick specimen of freshly mixed Riser Gel shall not sag over the cure period at 75 Deg. F when applied to a standard cement/asbestos (transite) substrate held in a vertical position (6 inch long dimension).

3.05 SETTLING: There shall be no indication of hard settling for any of the individual parts as indicated by a 7 or higher rating per ASTM D-869-78 after 168 hours at 150 Deg. F.

3.06 VOLATILES: There shall be no loss of weight greater than 2 percent for any individual part when held at 150 Deg. F for 24 hours.

3.07 WORKING LIFE: Minimum and maximum working life for mixed package shall be as specified as follows:

<u>TEMP. DEG. F</u>	<u>WORKING LIFE MINUTES</u>
40	90
60	40 Min. ✓
75	15 Min.
100	5 Min.

3.08 TENSILE SHEAR STRENGTH: The tensile shear strength of aluminum specimens bonded with appropriately mixed adhesive shall be as follows when tested at 75 Deg. F.

<u>CURE CONDITION</u>	<u>MINIMUM TENSILE SHEAR STRENGTH, PSI @ 75 DEG. F</u>
24 Hrs. @ 75°F	875
48 Hrs. @ 75°F	1350
7 Days @ 75°F	3000

3.09 LOW TEMPERATURE TENSILE SHEAR STRENGTH: The low temperature tensile shear strength bonded specimens shall be as specified:

<u>CURE CONDITION</u>	<u>MINIMUM TENSILE SHEAR STRENGTH, PSI @ 67 DEG. F</u>
7 Days @ 75 Deg. F	1600
7 Days @ 75 Deg. F 1 Hr. @ 180°F	1600

3.10 HIGH TEMPERATURE TENSILE SHEAR STRENGTH: The high temperature tensile shear strength of bonded aluminum specimens shall be as specified below:

<u>CURE CONDITION</u>	<u>MINIMUM TENSILE SHEAR STRENGTH, PSI @ 180 DEG. F</u>
7 Days @ 75 Deg. F	400
7 Days @ 100 Deg. F	400

3.11 WATER RESISTANCE: The tensile shear strength of bonded aluminum specimens shall be as specified below after the proper cure and submersion in distilled water at 160 Deg. F for 7 days.

<u>CURE CONDITION</u>	<u>MINIMUM TENSILE SHEAR STRENGTH, PSI @ 75 DEG. F</u>
7 Days @ 75 Deg. F plus 7 days under 160 Deg. F water	3000

3.12 FUEL RESISTANCE: The tensile shear strength of bonded aluminum specimens shall be as specified below after the proper cure and submersion in regular gasoline at 75 Deg. F for 7 days.

<u>CURE CONDITION</u>	<u>MINIMUM TENSILE SHEAR STRENGTH, PSI AT 75 DEG. F</u>
7 Days @ 75 Deg. F under gasoline at 75 Deg. F	3000

3.13 COLD IMPACT: The impact strength of bonded aluminum specimens shall be as specified below:

<u>CURE</u>	<u>MINIMUM IMPACT STRENGTH, FT. LBS. @ 67 DEG. F</u>
7 Days @ 75 Deg. F	6.0
7 Days @ 100 Deg. F	5.0

3.14 DURABILITY: The durability of bonded aluminum specimens shall be as specified below:

<u>DURABILITY</u>		
<u>CURE</u>	<u>TEST CONDITIONS & TIME</u>	
7 Days @ 75 Deg. F	7 Days @ 500 PSI	Pass
7 Days @ 100 Deg. F	7 Days @ 500 PSI	Pass

4.6 METHOD OF TEST

4.01 DENSITY: Test in accordance with ASTM D1475.

4.02 VISCOSITY: Determine viscosity in accordance with ASTM D562, Procedure B.

4.03 SETTLING: ASTM D-869-78 except test after conditioning for 168 hours at 150 Deg. F.

4.04 VOLATILES: WEIGHT 10 + or - 0.5 grams of the individual parts into tares 2 1/4 inch diameter smooth sided aluminum dishes to an accuracy of + or - 0.002 grams. Condition for 24 + or - 0.2 hours at 150 + or - 2 Deg. F in a circulating air oven, reweigh and calculate percent weight loss (volatiles).

4.05 WORKING LIFE: Precondition the container of one applicator gun at test temperature. Mix the kit thoroughly by applying 50 strokes (one stroke equals one back and one forward plunger movement) within 2 to 2½ minutes elapsed time. Start the timer, remove the mix rod, attach the nozzle, load the applicator gun, then extrude appropriately 1/5 of the contents. Maintain the container and applicator gun at the specified temperature. At the specified minimum time, insure that material can still be extruded from the container, and at the specified maximum time insure that material cannot be readily extruded from the container.

NOTE: The use of leather palmed gloves is recommended to minimize personal discomfort and to reduce extraneous temperature effects.

4.06 TENSILE SHEAR STRENGTH: ASTM D1002 using 2024T3 aluminum prepared in accordance with article 3.01 of these specifications. Bond and fixture specimens with a nominal 0.003 inch bond line thickness using a properly mixed container within the specified working life. Place the fixtured specimens in the proper cure environment. Test within hour of the completion of the specified cure.

4.07 LOW TEMPERATURE TENSILE SHEAR STRENGTH: Prepare specimens as in section 4.06 and test in accordance with ASTM D2557.

4.08 HIGH TEMPERATURE TENSILE SHEAR STRENGTH: Prepare specimens as in section 4.06 and test in accordance with ASTM D2295.

4.09 WATER RESISTANCE: Prepare specimens as in section 4.06 cure in accordance with section 3.11. Place the test specimens in a clean mason jar containing distilled water, cap and place in a 160 Deg. F oven. After 7 days, remove the jar from the oven, cool to 75 Deg. F, then remove one specimen from the water at a time, wipe dry and test immediately in accordance with ASTM D1002.

4.10 FUEL RESISTANCE: Prepare specimens as in 4.06 cure in accordance with section 3.12. Place test specimens in a capped clean mason jar containing regular gasoline at 75 ° or - 2 Deg. F. After seven days, remove one specimen at a time, wipe dry and test immediately in accordance with ASTM D1002.

4.11 COLD IMPACT: ASTM D950. Use 2024-T3 aluminum prepared and bonded as in section 4.06. Cure as indicated in 3.13. Cool test specimen at the test temperature for a minimum of 4 hours prior to testing.

4.12 DURABILITY: ASTM D-2919, test environment #4. Prepare specimens as in section 4.06 and cure as indicated in 3.14.

5. PACKING

5.01 PACKAGING: The material shall be packaged in unit containers of 10.5 Oz. size and shall be designed to separate the resin base from the curing agent in such a manner as to allow mixing within the container immediately prior to application.

5.02 PACKING: The individual packages per section 5.01 shall be packed in suitable containers and in such a manner as to ensure acceptance by common or other carriers for safe transportation at the lowest rate to point of delivery.

METHODS OF CONSTRUCTION

Before applying the bead of epoxy bonding and leveling compound, the surface of the existing frame to receive the compound and the lower bearing surfaces and sides to the extension units shall be brushed clean with a wire wheel to assure adhesion of the epoxy to the surfaces.

The wire brushed surfaces are then to be wiped with a piece of textile waste saturated with a rapid evaporating degreasing agent such as 1,1,1 trichlorethane.

The extension ring or frame is placed in the existing casting and checked for fit. Any excess void space should be noted and extra epoxy should be applied at that location.

The epoxy bonding compound shall be applied in accordance to the manufacturer's specifications.

The new extension frame shall be then pushed securely into the uncured epoxy to assure uniform contact between the frame and epoxy.

The grate or cover may then be placed on the extension unit with care so as not to change the position of the unit.

If in the opinion of the engineer, the existing grates or manhole covers are too loose and wobble after being set in the new extension frames, the contractor shall grind the existing grates and covers to obtain a tighter fit or replace them as directed by the engineer.

QUANTITY AND PAYMENT

The quantity of cast iron extension frames for existing manholes and inlets, for which payment will be made will be the number actually installed in accordance with the plans and specifications or as directed by the engineer.

Payment for cast iron extension rings and frames for existing manholes and inlets will be made for the quantity as above determined at the unit prices and bid for cast iron extension rings for existing manholes and cast iron extension frames for existing inlets in the proposal, which shall include all materials shown in the details and stated above and all else necessary therefore and incidental thereto.

A P P E N D I X 0

GUIDELINES FOR RAISING MANHOLE AND INLET HEADS

AND

THE USE OF EXTENSION RINGS AND FRAMES

by

E.J. Hellriegel
Project Engineer

NEW JERSEY DEPARTMENT OF TRANSPORTATION
Bureau of Transportation Structures Research

February, 1985

ABSTRACT

This report presents an analysis of the problems involved in raising the heads of manholes and inlets on resurfacing projects and outlines suggested remedial measures.

The recommended solutions address the method currently used in resetting heads, as well as more recently developed technology involving use of epoxy-bonded cast iron extension rings.

Application of the guidelines presented herein entails an evaluation of the condition of the existing manhole/inlet hardware and use of an empirical procedure for calculating the required "rise" of the head. The latter procedure should be particularly useful on resurfacing projects with abbreviated plans (i.e., those with no profile or grade sheets).

TABLE OF CONTENTS

		PAGE
1.0	INTRODUCTION	1
2.0	SPECIFIC AIM	1
3.0	BACKGROUND	2
4.0	EVALUATION OF EXISTING HARDWARE	2
4.1	Wear of Manhole Frames & Covers	2
4.2	Types of Wear	4
4.2.1.	Uniform wear	4
4.2.2.	Generalized non-uniform wear	4
4.2.3.	Localized non-uniform wear	4
4.3	Effects of Wear	9
4.4	Corrective Action	9
4.5	Effects of Wear on the Use of Extension Frames	10
4.6	Preparation of Castings	12
5.0	OTHER FACTORS FOR THE SUCCESSFUL APPLICATION OF EXTENSION UNITS .	12
6.0	PROBLEMS ASSOCIATED WITH RESETTING	13
6.1	Feathering	13
6.2	Depressed Covers and Associated Problems	16
6.3	Resolution of Problems	18
6.3.1	Feathering	18
6.3.2	Depressed Covers	21
7.0	RESPONSIBILITIES OF DESIGN ENGINEER AND THE CONTRACTOR	21
7.1	Design Engineer	21
7.2	Contractor	22
8.0	CALCULATING THE RISE	23
9.0	CRITERIA FOR SELECTING THE METHOD OF RAISING HEADS	23
9.1	General	24
9.1.1	Resets	25
9.1.2	Extension Rings	26
9.1.3	Extension Frames	27
9.2	Flow Chart for Decision-Making on Raising heads	28
9.2.1	Estimated Quantities for "If and Where Directed" Items.	28
10.0	RAMPING OF HEADS	29
11.0	SPECIFICATIONS FOR SELECTING EXTENSION UNITS & RESETTING HEADS ..	30
11.1	Progression of Measurements for Bring Heads to Grade	30
11.2	Limits of Rise for Determining Method of Bring Heads to grade	31
11.2.1	Rise Less Than 3-1/2 Inches	31
11.2.2	Rise Greater Than 3-1/2 Inches	31
11.3	Instructions for non-standard manhole castings	31

1.0 INTRODUCTION

The raising of manhole and inlet frames in preparation for an asphalt concrete overlay has been a standard highway practice for the last fifty years.

This seemingly simple operation is usually time-consuming, costly, and disruptive of traffic flow. In some of our urban areas, the number of manhole and inlet castings (heads)* which must be raised prior to resurfacing can exceed 120 units per mile. Depending on the number of units on a particular project, the contractor may begin raising of the heads from four to six weeks before the paving operation, thereby creating a continuing source of annoyance to the motorist as well as a possibly hazardous condition in the travelled way.

As a result of a recent Department Study, titled "Second Generation Overlays", an improved procedure for raising manhole and inlet heads has been developed. This improved practice is based on the use of epoxy-bonded cast iron extension units. (A note on terminology: The extension unit used to raise manholes is referred to as an "extension ring"; the comparable unit for inlets is an "extension frame".

2.0 SPECIFIC AIM

The objective of this report is to present guidelines for design engineers covering all facets of raising heads. The major topics discussed include the traditional practice for resetting existing manhole and inlet frames, the technique employing extension rings and frames, and a temporary ramping procedure necessary to produce a safe ride.

* "Heads" is the common expression for head castings consisting of cast iron frames, grates and covers used in constructing manholes and inlets.

3.0 BACKGROUND

Past experience with extension rings breaking loose and manhole covers, popping out caused the Department to prohibit their use for any application other than raising inlets in shoulder areas.

The successful application of the newly designed extension units and the technique employed was demonstrated in the investigation "Second Generation Overlays" performed by the Division of Research & Demonstration.

During this investigation the common cause for most of the problems associated with manholes was wear.

4.0 EVALUATION OF EXISTING HARDWARE

Highways are often repaved or rehabilitate with no more than cursory attention being paid to the highway hardware. If a manhole or inlet is tilted or collapsing, more often than not, it will be raised using the same hardware.

Manholes located in the travelled way are subjected to spalling (from snow plows) and wear (Photo 1). Sanitary sewer manholes can be subjected to both of the foregoing as well as deterioration by a corrosive atmosphere (photo 2).

4.1 Wear of Manhole Frames and Covers

Manhole wear can lead to popping out of covers [a devastating safety hazard] and a rough riding pavement.

The wear of manhole castings--both the frame and cover, is due to movement under traffic. The degree of wear is dependent mainly on two things: (1) the amount and type of traffic and, (2) the location in the travelled way.

Wear is exacerbated by the sand and dirt that enters the space at the peripheral interface between the cover and frame. Under the action of

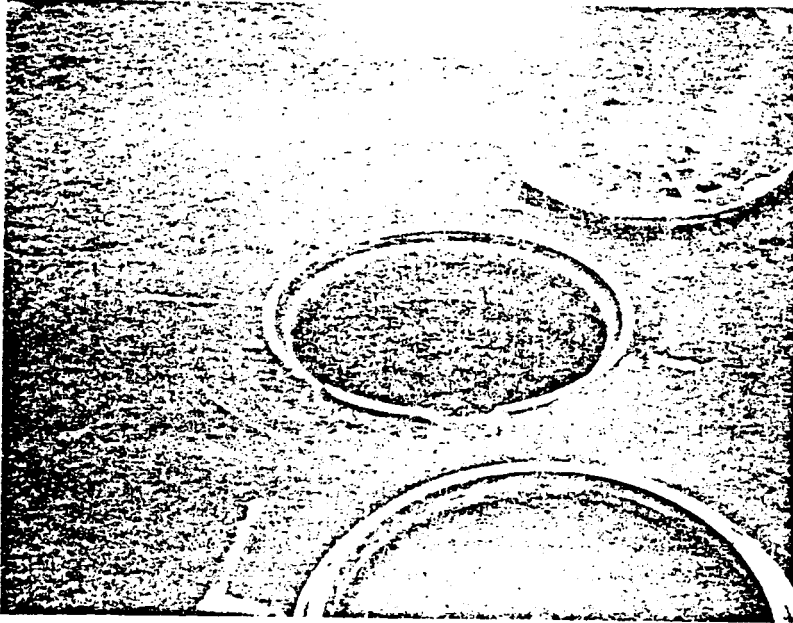

PHOTO 1:
SPALLED MANHOLE FRAME

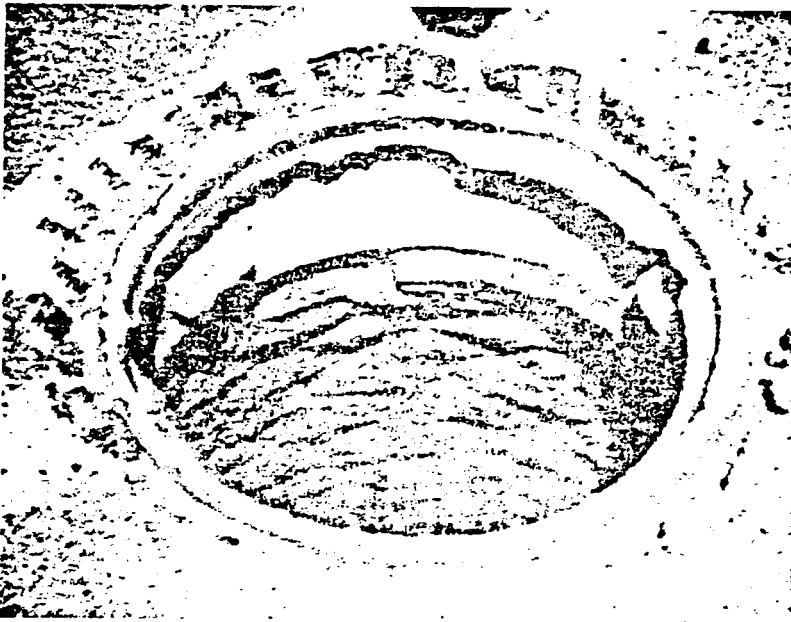

PHOTO 2:
CORRODED SANITARY SEWER MANHOLE FRAME

traffic, these abrasive materials can wear both the bottom of the cover and seat of the frame.

4.2 Types of Wear

Three types of wear may occur; uniform, generalized non-uniform and localized non-uniform wear.

4.2.1 Uniform Wear

Uniform wear occurs when the cover moves in a circular motion, rotating as much as 360° in one to three months (Photos 3 & 4). This type of motion causes the cover to drop below the top of the frame and surface of the roadway (photos 5 & 6).

4.2.2 Generalized Non-Uniform Wear

In some cases the cover moves in a to and fro motion with minimal rotation. This causes both the cover and seat of the frame to establish a mating concave-convex configuration, usually tapering to the leave edge of the manhole (photos 7 & 8).

4.2.3 Localized Non-Uniform Wear

Localized non-uniform wear also occurs when the cover moves in a to and fro motion with no rotation. In this case however, the wear is fairly uniform across the seat except the area under the pick holes of the cover. Here the seat maintains its original height as the rest of the seat is worn away. The result is a 3/16" to 1/4" high, 1" long plateau with rounded edges. (see photos 9 & 10)

If the proper corrective action is not taken, continued wear of the frames and cover will create a variety of safety problems and effect the rideability as well.

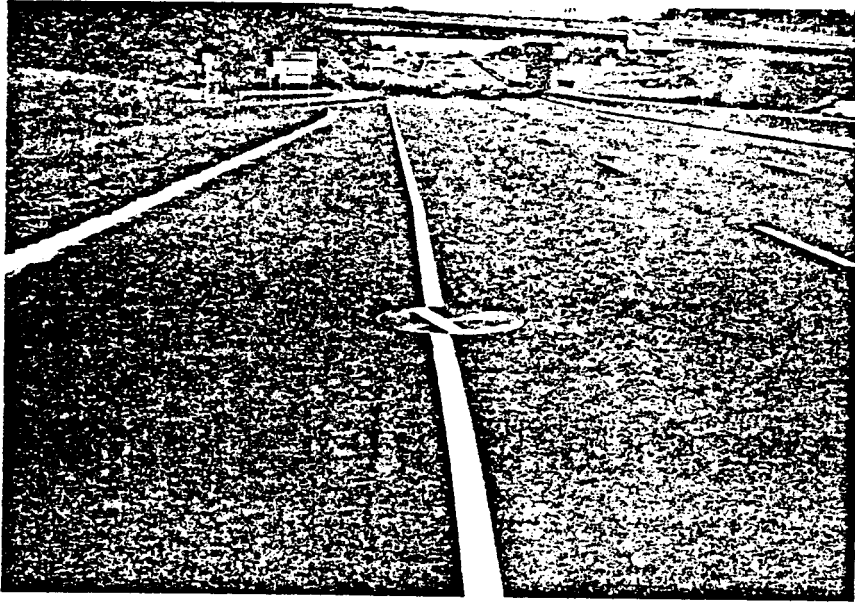

PHOTOS 3 & 4
ROTATING COVERS

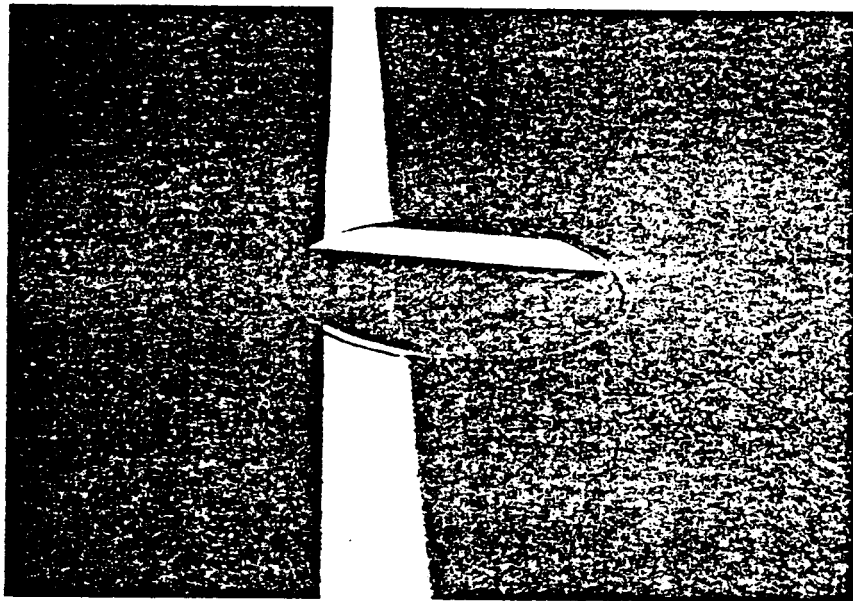

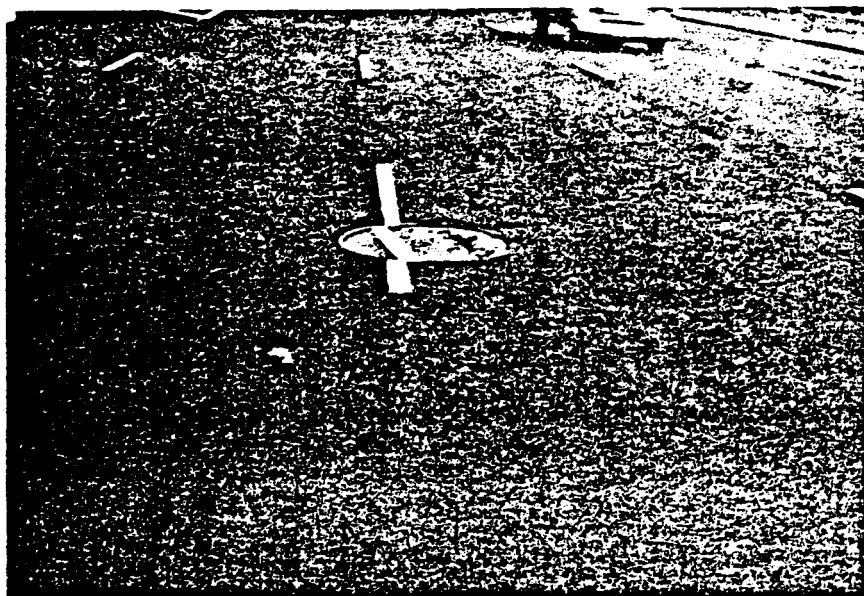

PHOTOS 5 & 6 (UNIFORM WEAR)
COVER DEPRESSED DUE TO WEAR OF COVER SEAT



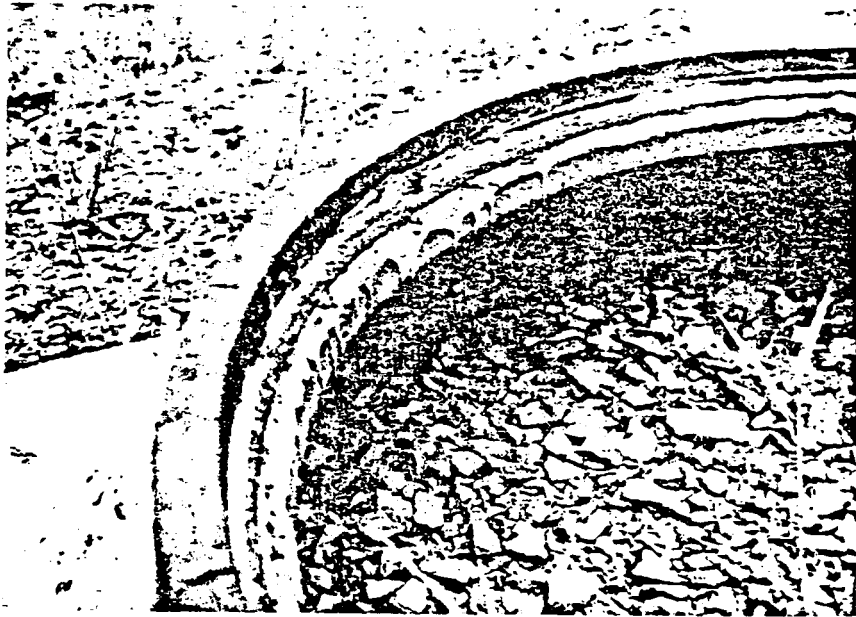

PHOTO 7 & 8

GENERALIZED NON-UNIFORM WEAR OF MANHOLE FRAME

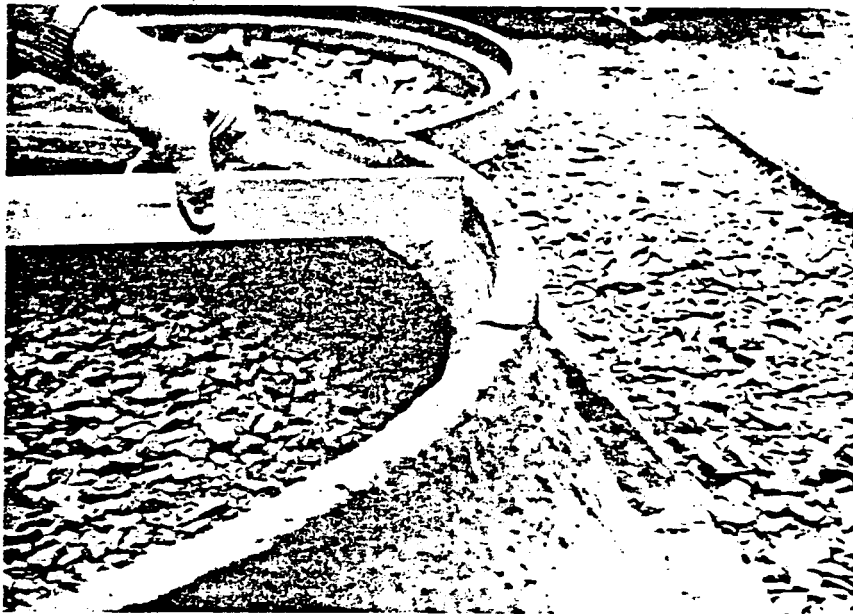



PHOTO 9 & 10
LOCALIZED NON-UNIFORM WEAR



4.3 Effects of Wear

Uniform wear of the frame and cover will effect the riding quality of the pavement as the cover progressively moves down. As wear continues, the interface of the cover and frame will round, with the possibility of the cover sliding out or the seat collaping under the impact of traffic.

If a frame and cover wear non-uniformly and the cover is removed and then replaced indiscriminantly on the manhole frame, the cover becomes an ideal candidate for being flipped out by a vehicle riding over it. The way to eliminate this problem is to mark the frame and cover with a lumber crayon (keel) to insure its exact replacement. Note: This marking procedure should be followed anytime a cover is disturbed since the type of wear wouldn't be apparent until the cover is removed.

4.4 Corrective Action for worn frames and covers

When a manhole is to be raised using the traditional resetting procedures and the existing hardware is excessively worn or in other-wise poor condition, a new frame and cover should be used.

- While such new hardware can be expensive, when one considers the safety and poor rideability consequences of using worn hardware, use of a new frame and cover is obviously the prudent course of action. As outlined below, one of the advantages of the extension ring technique is that it is relatively more "forgiving" of wear and corrosion of the existing hardware. If the choice is made to raise the head using traditional procedures, field forces must make some judgmental evaluations of the condition of the existing hardware and the effects of that wear upon the subsequent performance of the raised manhole. While this would require a case-by-case evaluation, one

general guideline is that if wear causes the cover to be depressed more than 1/4" below the top of the frame, this degree of wear should be considered excessive and a new frame and cover should be specified.

4.5 Effect of wear on the use of extension rings

Extension rings can be used on spalled frames with good seats or on frames with a good top and badly corroded seat. An extension ring essentially renews the condition of the frame and saves the cost of excavating and replacing the frame.

When an extension ring is placed on a manhole frame which exhibits uniform wear or generalized non-uniform wear as described in 4.2.1 & 4.2.2, there may be little or no bearing of the lower surface of the extension ring on the seat of the manhole frame and no bedding or bonding of the epoxy as shown in photo 11. An epoxy which does not have the ability to leave a bead and make contact with both of the surfaces suffers a loss of approximately 40% of the intended bonding power. This problem is resolved through the use of a non-sag, rapid setting epoxy gel.

In placing an extension ring on a casting exhibiting localized non-uniform wear as described in 4.2.3, the projection of the non-worn part of the seat in the vicinity of the pick holes also prevents the proper bedding and bonding of the extension ring. This unworn segment of the seat can in certain cases (such as wear at the top of the old manhole frame) cause rocking of the ring and cover and failure by cracking of the extension ring (photo 12). This cracking may occur as follows: as vehicles strike the approach side, the ring is pressed down striking the seat; milliseconds later, the ring is violently depressed on the trailing side with a resounding impact. Repeated impacts can cause failure of the cast iron ring. The way to alleviate

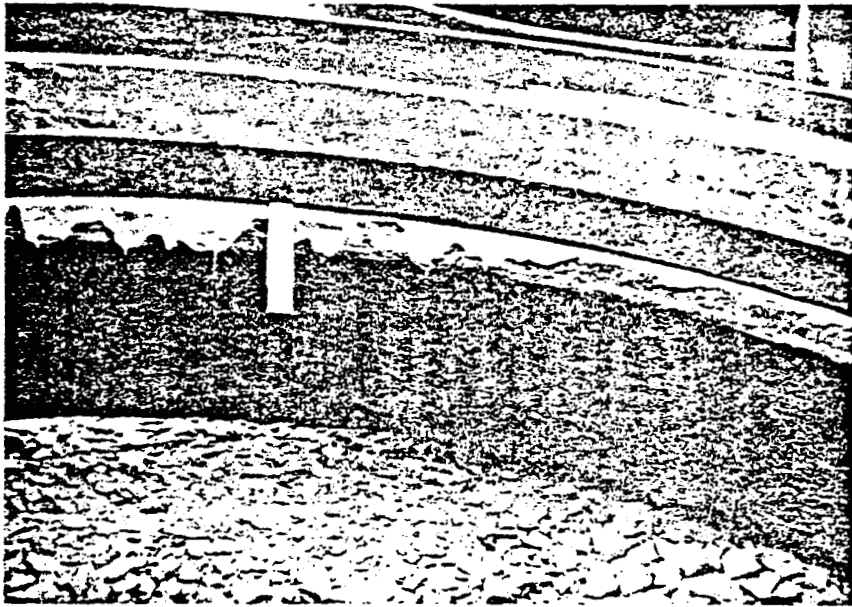

PHOTO 11: POOR INSTALLATION PRACTICES;
NO CONTACT OF EXTENSION RING WITH EPOXY

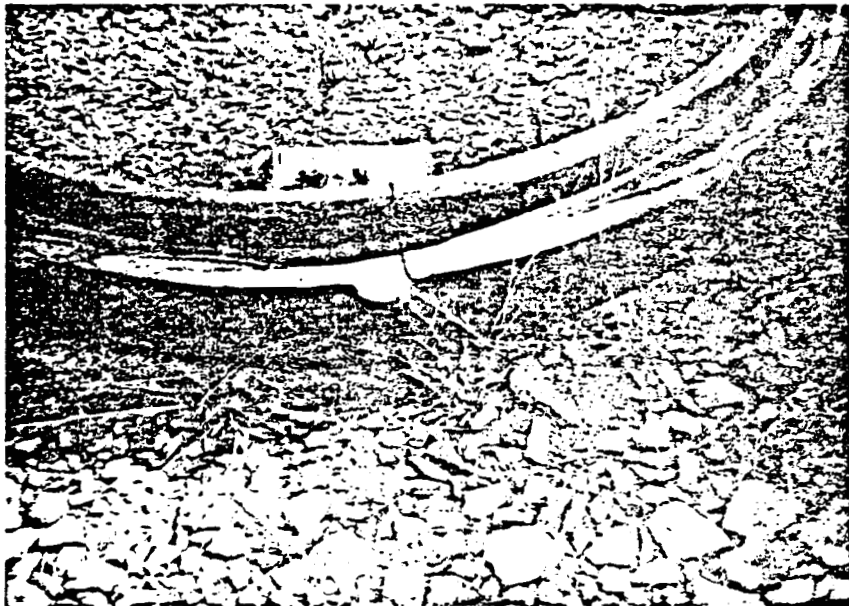

PHOTO 12
CRACKING OF EXTENSION RING DUE TO UNEVEN SEATING

this situation is to grind off this small plateau and place the normal amount of epoxy on the top of the frame and a heavier amount on the seat of the existing casting.

4.6 Preparation of Castings for Application of Epoxy

In order to assure proper bonding of the extension unit to the casting by the epoxy, the surfaces must be clean and free of any rust encrustation. [Sanitary sewer hardware is usually the oldest in the field and the hardest to clean due to deterioration by the corrosive sewer gas atmosphere.]

The best method to prepare the surfaces would be by sandblasting. Brushing with a wire wheel in an electric or pneumatically driven drill has given satisfactory results. As a word of caution: A wire wheel after an hour or so of use has the tendency to bend the wire away from the direction of rotation. This bending of the wire tends to burnish the rust rather than remove it. The useful life of the wire wheel can be extended by alternately reversing the wire wheel on its mandrel.

Hand brushing is a slow, tedious, process when done properly and is not adequate for the cleaning of all castings. Accordingly, use of a hand wire brush is not to be permitted.

5.0 OTHER FACTORS FOR THE SUCCESSFUL APPLICATION OF EXTENSION UNITS

The use of epoxy bonded extension rings and frames for raising heads is a fairly new technology. Most contractors and inspectors are seeing this application for the first time. The degree of success will be dependent on several things:

1. A clear knowledge of what is expected
2. The integrity of the contractor's workers in doing what is expected.

3. The diligence of the state inspector in seeing what is expected is carried out.
4. Selection of the proper size and height of the extension ring or frame.
5. The physical condition of the units to be raised.

6.0 PROBLEMS ASSOCIATED WITH RESETTING

The major problems associated with resetting heads are failure to bring them to the proper elevation and the use of faulty existing hardware. Heads set at the improper elevation result in excessive feathering. Faulty hardware results in depressed covers.

6.1 Feathering

Feathering of the bituminous mat is commonly used as a method of matching the elevation of a manhole. This is especially true where a thin cosmetic overlay has been applied without the benefit of raising the head.

Excess feathering around manholes and inlets can cause poor rideability, segregation of the mix due to over-raking and premature failure of the pavement due to stripping (photo 13, & 14).

In some cases, even less care is taken around inlets. Some grates have been observed to be 2 to 3 1/2 inches below the surrounding pavement (see photo 15 & 16). This creates a hazardous condition as well as a litter trap.

Normally, manhole frames are reset to the thickness of the proposed overlay, with no adjustment to correct for any existing feathered condition. The result is a low manhole head in the new overlay and the consequent need for additional feathering.

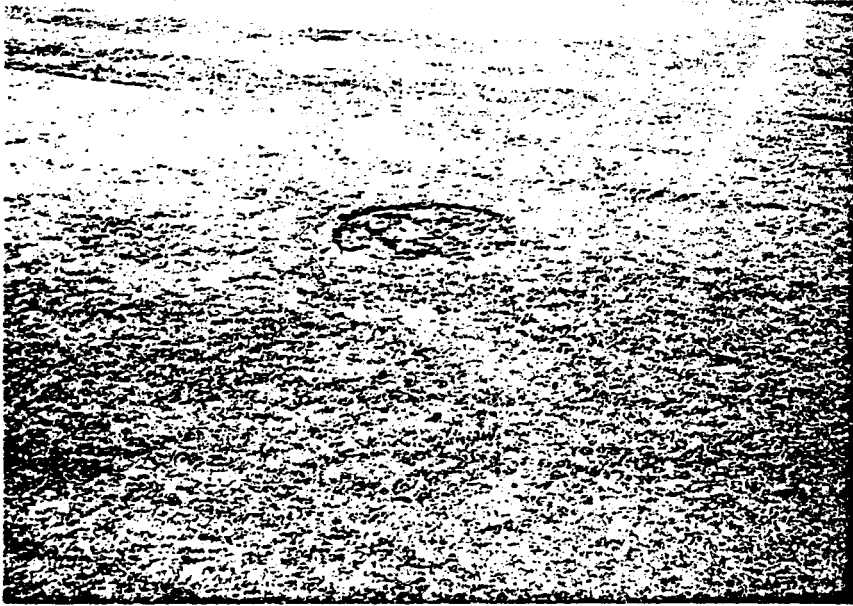

PHOTO 13
POOR RESET - POOR RIDEABILITY

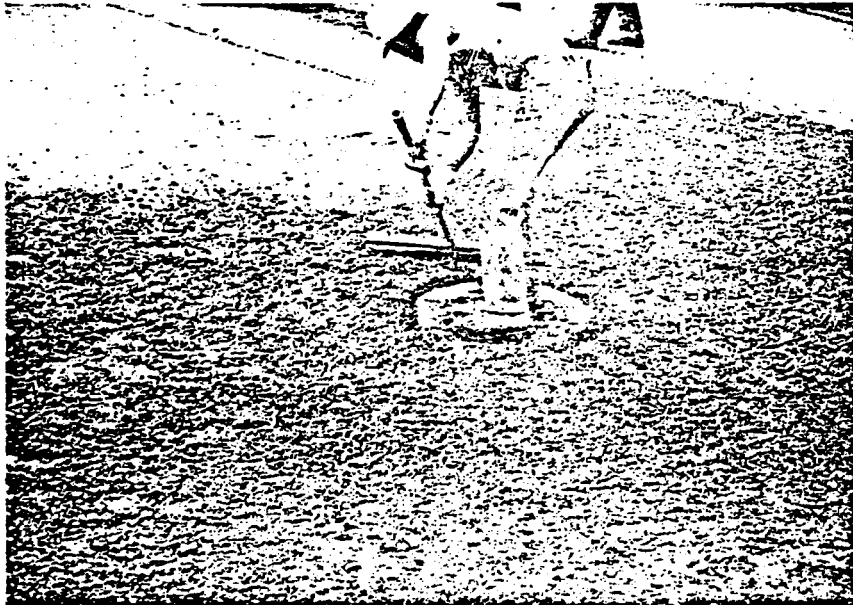

PHOTO 14
EXCESSIVE FEATHERING AND MIX SEGREGATION

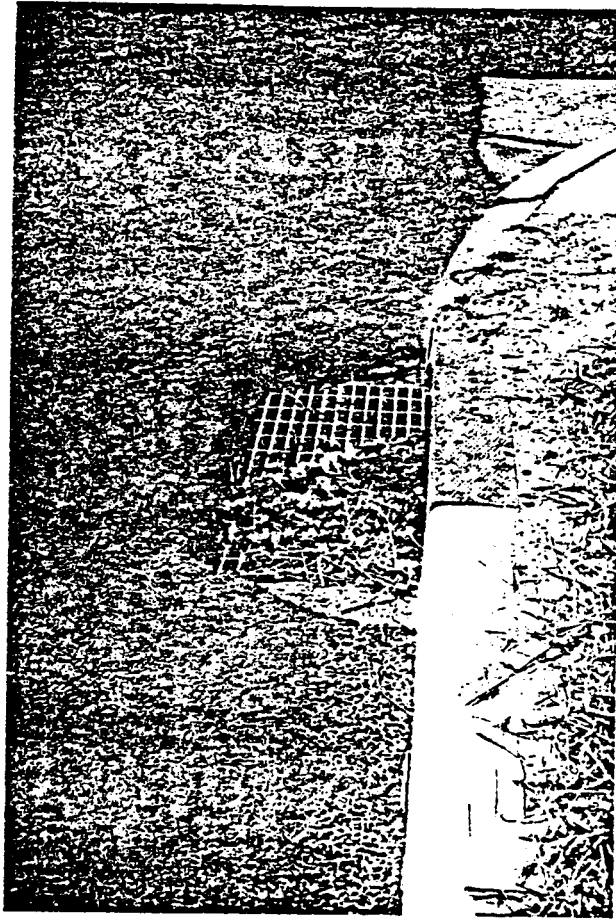

PHOTO 15
FEATHERED INLET, LITTER TRAP

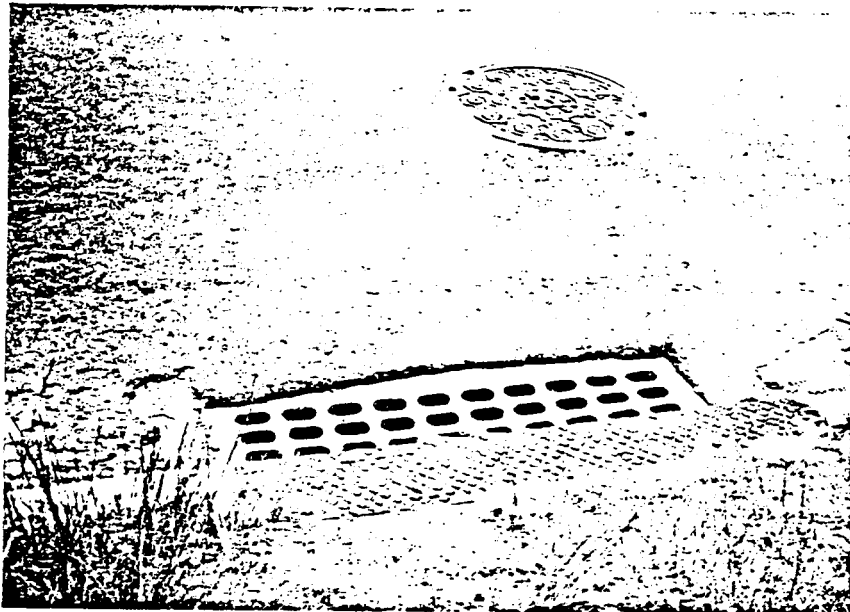

PHOTO 16
DEPRESSED INLETS

The problem of low heads requiring feathering has been exacerbated by the Department policy changing the method of payment for paving from square yards to tonnage. Payment by tonnage typically results in an overrun of material, causing a lift thickness greater than specified. This increase in thickness was verified by pavement cores taken from various projects during the 1983-84 paving season. On 1-1/2 inch and variable overlay projects, the average thickness was 1.82 inches. On nominal 3 inch (two course) surfacing projects, the average core thickness was 3.55 inches. Given these typical overruns, it is obvious that if a unit is raised only to the design thickness, feathering will be necessary.

6.2 Depressed Covers and Associated Problems

The use of worn frames and covers creates a depressed cover with associated rideability and safety problems. The following example illustrates the magnitude of the problem which can occur from such a situation.

On two recent overlay projects, utility companies raised manhole frames which had been in service for decades. The covers were depressed from 1/2 to 1-3/16 of inch below the frame and surface of the roadway (Photo 17). This condition of depressed covers caused an otherwise smooth pavement to be considered a rough riding pavement by the motorist. (Photo 18)

To provide a specific indication of the roughness imparted by the poor resetting practice, the pavement was tested with a "Mays Ride Meter". The Mays Ride Meter consists of an instrument package mounted in a standard passenger car which measures road smoothness in terms of a relative movement between the car body and the differential housing.

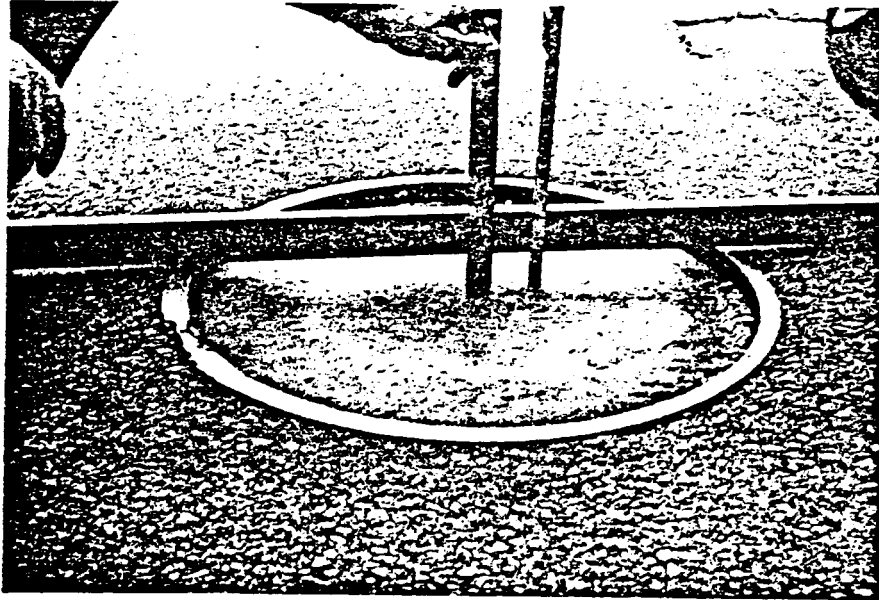

PHOTO 17
HAZARDOUSLY DEPRESSED COVER

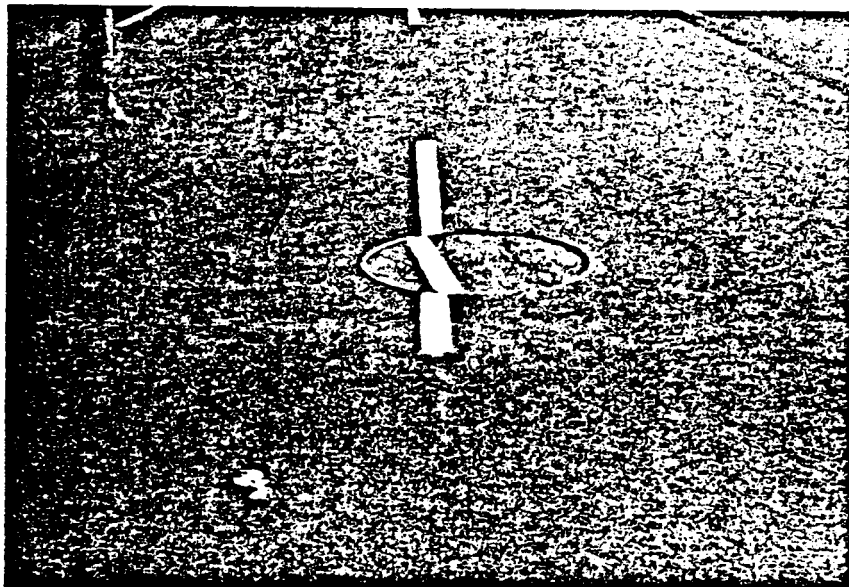

PHOTO 18
DEPRESSED COVER; POOR RIDEABILITY

The amount of travel between the differential and body of the car give a specific indication of roughness caused by a depressed manhole cover. Mays Ride Meter readings on this particular project showed that the roughness in the vicinity of the depressed manhole covers was as much as 8.5 times that of the surrounding pavement.

Besides producing a rough ride, worn covers present a safety hazard. Photo 19 shows an old frame with a badly worn cover that was reset without the benefit of a bituminous ramp about the head. This condition imparted dynamic jump to the wheels of the truck which landed on the cover, breaking it. (Photo 20). Trucks riding over worn covers in the finished surface or unramped resets during construction create a source of annoyance to residents in the form of irksome noise (Photo 21).

A dynamic jump can also result from a depressed cover, i.e., as the wheels pass over the cover, they drop down momentarily, then strike the higher manhole frame and impart dynamic jump to the vehicle. As the wheels land on the newly-placed pavement, the impact can shove the material ahead of the wheel, causing a bump to form (Photo 22). This pavement distortion not only effects the riding quality, but could also cause vehicle handling problems or problems in snow removal.

6.3 Resolution of Problems

6.3.1 Feathering

Feathering can be eliminated by paving to an engineered elevation and cross slope. Since many resurfacing projects are not fully engineered, a correction for prior feathering and expected thickness overruns often must be made.

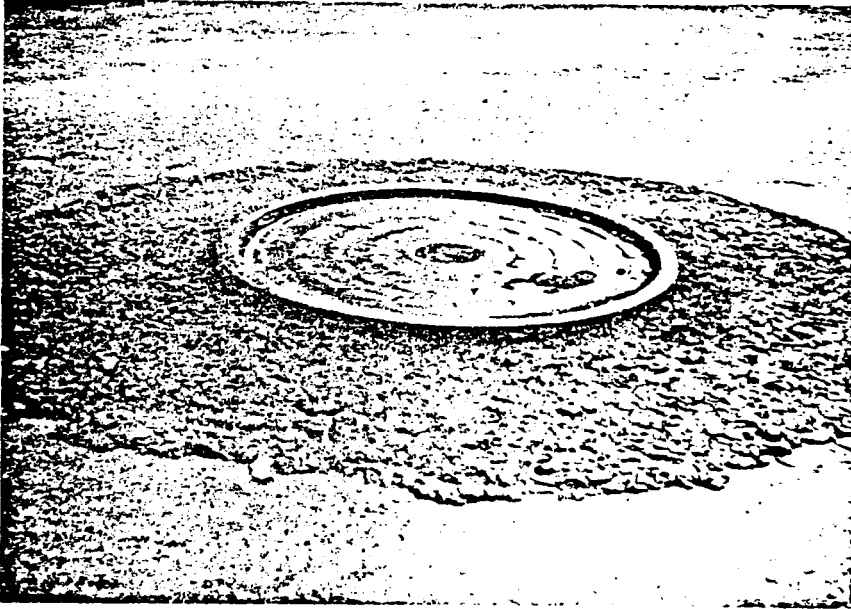

PHOTO 19

DEPRESSED COVER ON RESET MANHOLE FRAME

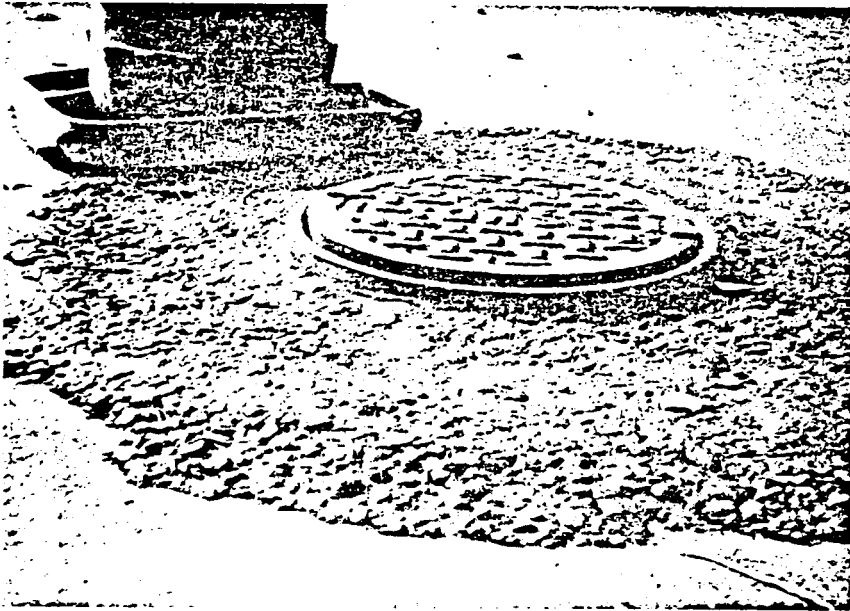

PHOTO 20

DEPRESSED RESET SANITARY HEAD - NO RAMP
COVER BROKEN BY DYNAMIC JUMP OF TRUCK

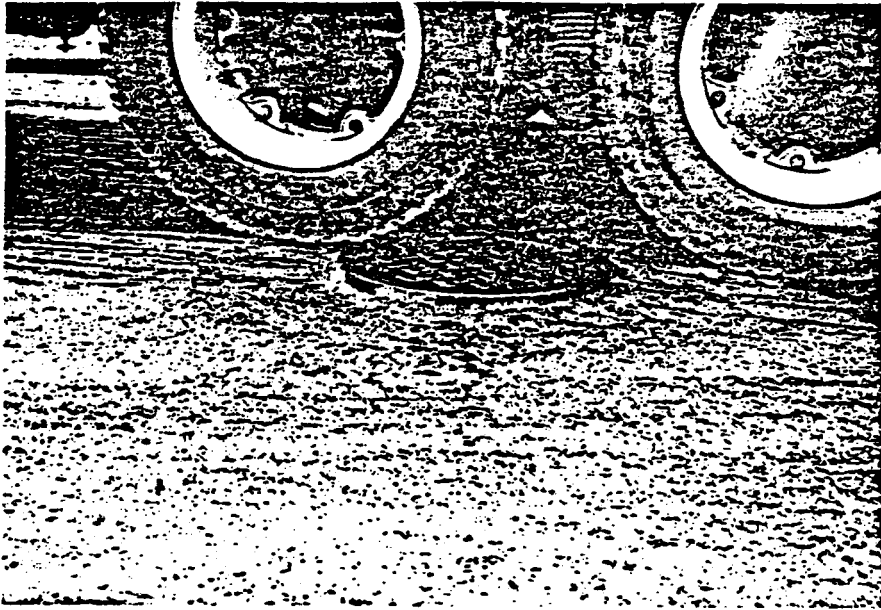

PHOTO 21

UNRAMPED RESET HEAD AS A SOURCE OF ANNOYING NOISE

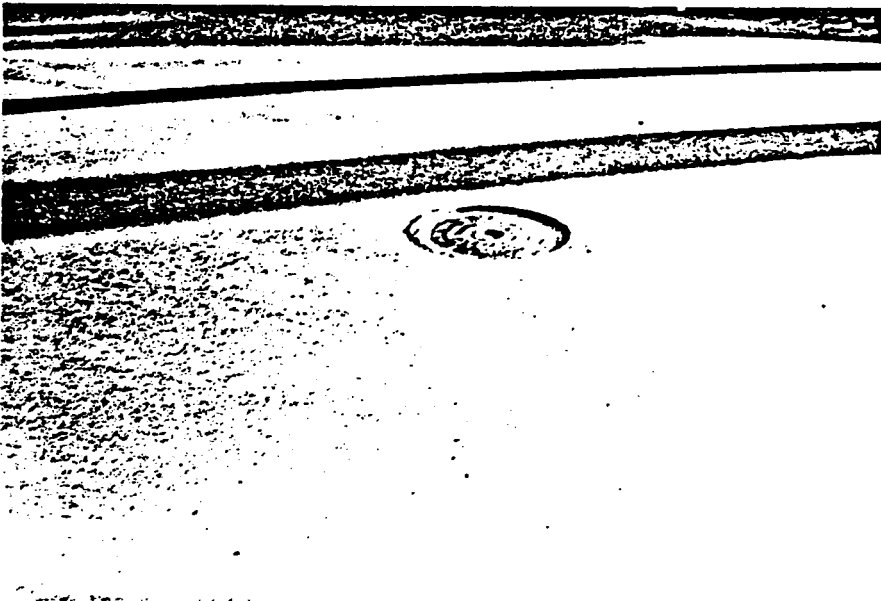

PHOTO 22

WORN HEAD CAN CAUSE DYNAMIC JUMP AND PAVEMENT DISTORTION

This correction, when added to the specified nominal overlay thickness, will provide a satisfactory estimate of the height the head must be raised to bring it to the proper elevation.

6.3.2 Depressed Covers

As shown previously, excessive wear will result in a depressed cover. Based both a safety standpoint and smoothness of ride, if a manhole cover is more than 1/4 inch below the frame, it should not be reset; the condition will only worsen. A new frame and cover (or an extension ring and cover) should be specified.

7.0 Responsibilities of Design Engineer and the Contractor

7.1 Design Engineer

The Design Engineer will be responsible for determining the general method to be used in raising the heads on a particular project: i.e., resetting or extension rings. The criteria to be employed in making that decision are outlined in Section 8 of this guide. As outlined in that report subsection, the primary factor affecting the decision as to the choice of methods for raising manhole heads is the height to which the head should be raised. In particular, if the new elevation is less than 1-1/2" or more than 3-1/2", resetting will be employed. If the new elevation is in the range of 1-1/2 to 3-1/2", an extension ring will be specified.

The Design Engineer or his representative will make an initial determination of whether the existing hardware is adequate; specifically whether a new manhole cover is required. The designer will make a "windshield" survey of a proposed project and if a particular cover appears to be more than 1/4" below the frame, a replacement cover will be specified (see Section 6.3.2).

Whether such new cover will be used in conjunction with a new frame (i.e., resetting), or with an extension ring, will be dependent on the height to which the head should be raised, (i.e., the "rise") as computed in Section 8.1.

7.2 Contractor

The contractor of course bears the ultimate responsibility for insuring that heads are brought to the proper elevation.

On fully engineered projects (i.e., those with profiles and cross slopes), determination of the elevation of the heads should not be a particular problem since the amount the head should be raised can be easily calculated. On projects with abbreviated plans, --those with no profile or cross section sheets-- the contractor must take into account the present elevation and cross slope of the manhole/inlet hardware.

To assist the contractor in calculating the proper rise for a resetting or extension ring, the procedure outlined in Section 8.1 is offered as a guide. This empirical procedure -- which takes into account existing "feathering" around the manhole frame and expected thickness overruns, as well as the nominal overlay thickness -- should be of particular use on those projects with abbreviated plans.

Regardless of the procedure used for raising the heads, it is essential that the contractor inspect the existing manhole masonry and frames to determine whether the unit must be reconstructed or if a cracked frame should be replaced, etc. When proposed overlay work contemplates a change from the existing cross slope and an extension ring is specified, the

contractor should order a ring with the necessary slope change built in.

In urban areas a variety of manhole frame cover designs and sizes may be encountered. The contractor will be responsible for measuring the existing units and ordering all the proper size rings, frames, and/or covers. When a manhole is other than a standard Department of Transportation unit and a new cover is required, such cover will be replaced in kind, i.e., if the manhole has a solid (vented) cover, it will be replaced with a solid (vented) cover.

8.0 CALCULATING THE RISE

1) In calculating the rise of a head to the new elevation, a correction for prior feathering must be made. This will be accomplished by placing a minimum eight-foot straightedge across the pavement spanning the manhole and measuring the distance to the top of the frame.

2) A correction must also be made for the expected thickness overruns. This overrun correction factor will be

1/4 inch for 1-1/2 and 2 inch resurfacing projects

3/8 inch for 3 inch resurfacing projects

Cumulatively, the height or rise a particular head must be raised to bring it to the proper elevation will be calculated as: the distance from the straightedge to the frame plus the specified overlay thickness plus the expected overrun thickness equal the rise. Succinctly it would be:

Distance from	Specified Overlay	Expected Thickness	
	+	+	= Rise
Straightedge to Frame	Thickness	overrun	

9.0 Criteria for Selecting the Method of Raising Heads

9.1 General

The decision as to whether a particular head will be raised using traditional resetting procedures or, alternatively, through use of an extension frame, requires analysis of a number of variables. These include:

- 1) The height to which the head is to be raised.
- 2) The maximum height of the casting above the roadway surface when open to traffic.
- 3) The prevailing traffic speed and volume.
- 4) The location of the head (e.g., traveled way versus shoulder).
5. Expected interference with traffic flow.
6. The condition of the head to be raised.
7. The relative cost of raising a head (e.g., resetting in concrete pavement are generally more expensive).

Note well: The foregoing factors are to be analyzed in light of the fact that out of concern for motorists safety and comfort, the Department has adopted the policy that not more than 1-1/2 inches of a head may protrude above the roadway surface for more than 48 hours on mainline pavements. On low speed, low volume roads, residential streets, or in the shoulders of state highways, the 48 hour limit on the 1-1/2 inch rise may be extended at the discretion of the engineer. While some case-by-case analyses of the above listed seven factors will need to be made, the general rule will be that if the rise of head is in the range of 1-1/2 to 3-1/2", an extension unit will be specified. If the rise to the new elevation is less than 1-1/2" or more than 3-1/2", the head will be reset.

The raising of heads in advance of the paving operation disrupts and/or slows the flow of traffic. The degree of disruption will be

dependent primarily on the number of units to be raised and the size of the work force engaged in this operation. Normally, the work commences after the heavy flow of morning traffic and ceases before the heavy flow of evening traffic, producing a shortened work day. A reset in a concrete pavement is much more labor intensive than a reset in a bituminous pavement section. This typically results in the resetting of 2 to 3 units per day in concrete and 4 to 5 units per day in bituminous pavement. In contrast, 14 to 18 extension units can be placed in a day regardless of the type of pavement.

9.1.1 Resets

In keeping with Department policy, new elevations exceeding 3 1/2 inches will be reset according to the following procedure. On multi-course resurfacing projects, the base and/or binder course will be placed before a manhole frame is raised. This increases the degree of accuracy in bringing the manhole to the proper grade and cross slope and leaves no more than 1-1/2 inches of casting exposed to traffic; thus providing a greater measure of safety and comfort to the motorist. With only 1-1/2 inches exposed the roadway can be safely opened to traffic.

In opening the roadway to traffic, a word of caution must be noted. The use of ordinary mortar used in laying the brickwork on rebuilt or reset manholes can result in bond failure due to impact loading. Therefore, a fast setting, non-shrink mortar developing a one hour compression strength of 2500 psi should be specified.

On some multi-course resurfacing projects, a contractor may for the sake of expediency elect to stack two rings rather than reset the manhole frame. This has been successfully demonstrated in

the field and is permissible. It may be more economical as well. By way of comparison, on a 4 to 6 inch resurfacing, a manhole would have to be covered over with the first two courses and then reset prior to placement of the surface course. This would require locating the head, excavating a 45 inch or greater diameter circle 12 to 14 inches deep, resetting the head with brickwork, fill the excavation with hot mix and tamping, then provide a ramp around the exposed portion of the head. If it was a manhole head that required replacement there would be the additional cost of a new frame and cover.

With the placement of two rings, the worse case scenario would be one ramp with no excavation. If the plans call for a change in cross slope; a ring with the proper cross slope can be ordered. It should be noted that 1-3/4 inches is the minimum thickness for a ring with a built in cross slope.

9.1.2 Extension Rings (Manholes)

Except in unusual cases, on single or two course resurfacing projects not exceeding 3-1/2 inches on mainline pavement, an extension ring will be used to raise heads in line with departmental policy.

When installing the extension ring, any rise above 1-1/2 inches must be paved over and reset before the surface course is placed, unless the binder course is placed before opening to traffic. It should be noted that minimum thickness for a manhole extension ring is 1-1/2 inches. Any height adjustments in the range of 1-1/2 to 2-1/4 inches will require a new 1 inch cover. Since the standard cover is 2 inches thick, any salvageable cover in good

condition can only be used in an extension ring 2-1/2 inches or more in height.

9.1.3 Extension Frames (Inlets)

The minimum height of an inlet extension frame is 1-3/4 inches. A great many inquiries have been made by consultants and design engineers as to how a 1-3/4 inch extension frame can be used with an 1-1/2 inch overlay. Experience has dictated that most inlets are already dished or depressed and it is not uncommon to use a 2, 2-1/2 or 3 inch extension frame to match the elevation of a new 1-1/2" overlay.

When used on combination inlets, extension frames present no problem with blocking off the curb opening on 8, 10, and 12 inch curb pieces. On a 6 inch curb piece, the opening would be virtually blocked off. This, however, presents no problem since hydraulic tests have shown the curb opening has little effect on the hydraulic capacity of a combination inlet except when in a sump condition or on an extremely flat grade with a severe cross slope.

The savings of not having to remove and replace the curb and raise the head could be substantial, especially when in a barrier curb.

By virtue of a recent statute (Chapter 283 of the Laws of 1983), the utility companies will be reimbursed for all relocations needed to accommodate any project administered through the Department of Transportation. Accordingly these utility companies will be required to conform to Department Standards (e.g., with respect to resetting heads).

9.2 FLOW CHART FOR DECISION MAKING ON RAISING HEADS

The flow chart presented as Figure 1 was developed to aid the engineer (NJ DOT, consultant or contractor) select the method for raising heads in several types of overlays:

- 1) A fully engineered design project paving to a planned profile and cross slope.
- 2) A project where no profile or cross slope is given and a uniform design thickness (3 inches) is being placed, subject to the profile as picked up by a ski grade follower.
A modification of this would be a determined thickness (i.e., 1-1/2 inches and variable) with a given cross slope.
- 3) An abbreviated plans project with little or no engineering, where no profile or cross slope is given (i.e., match existing cross slope) and the Departments thickness provisions do not apply.

In the latter case, the selection is straightforward--an extension ring and new 1 inch cover for overlays between 1-1/2 and 2-1/4 inches. For overlays 2-1/2 to 3-1/2 inches thick an extension ring and standard 2 inch cover should be used. For inlet extension frames, the minimum rise is 2 inches with an 1-1/2 inch overlay as explained in section 9.1.3.

9.2.1 Estimated Quantities for "If and Where Directed" Items

If a survey crew is not going to be used to collect the necessary data as to the condition of all the highway hardware (state & utilities) then provision for reconstructed inlets, reconstructed manholes, new manhole castings, new manhole covers and cast iron curb pieces should be included as "if and where" directed items. The following table provides some guidance as to the number of units to included.

	# of units on project	
	100	50
reconstructed inlets type	5	2
reconstructed manholes	5	2
new manhole castings	5	2
new manhole covers	5	2
cast iron curb pieces	10	5

10.0 RAMPING OF HEADS

At present, raised heads are left protruding above the old pavement (Photo 22) or at best may have a skimpy 6 to 8 inch ring of hot or cold mix material placed around the casting. This creates not only a rough ride, but can be hazardous to cyclists and pedestrians. Another problem is the noise created by an empty truck passing over a raised head. In order to alleviate these problems and encourage good public relations, Department policy dictates that the ramping around the heads will be constructed as follows:

- 1) On single course (1-1/2" & variable) projects a 36 inch circular ramp of hot mix will be placed about the periphery of the manhole leaving 1/2 inch of the extension ring exposed. Leaving the 1/2 inch exposed should avoid under-compacted, shoddy appearing areas (due to feathering) when the surface course is placed. In those cases where cold mix is used for convenience by the contractor, it will be removed prior to placing the hot mix surface course.
- 2) For multi-course resurfacing projects the base and/or binder course should be placed before the head is raised. This increases the degree of accuracy in raising the head to the proposed elevation and is a way

of achieving the policy of having not more than 1-1/2 inches of exposure for more than 48 hours.

- 3) For a 3 inch resurfacing where 1-1/2 inches are to be milled off, after milling the 36 inch wide bituminous ramp will be placed as for the single course in (1). Then with the placement of the binder course, the head will than be flush with the pavement.

This is an excellent method to be use either in stage construction or at the end of a paving season. Prior to paving of the surface course the proper extension ring and method of ramping will be pursued. This procedure is extremely benefical in the case of inlets where it preempts ponding and/or the associated icing conditions around inlets.

- 4) For the occassional 2 inch overlays, ramps will be constructed the same as for the 1-1/2 inch course.

11.0 SPECIFICATION FOR SELECTING EXTENSION UNITS AND RESETTING HEADS

11.1 Progression of Measurement for Bringing Heads to Grade

The following should be added to the standard specifications under "Methods of Construction" in the sections on the Use of Cast Iron Extension Inlets and "Reset Heads".

1. A minimum eight foot straightedge will be placed across the manhole or inlet.
2. Measure down to the frame and record as A.
3. Measure down to the cover and record measurement as D.
4. Record the thickness of proposed overlay as follows:

$$\begin{array}{l} \text{Thickness of overlay } 1-1/2" + 1/4" = B \\ \text{" " " } 2 + 1/4 = B \\ \text{" " " } 3 + 3/8 = B \end{array}$$

5. Select which B is apropos to the proposed thickness.
6. Record rise needed from the formula $A + B = R$

The same method is used to calculate the height for a reset.

11.2 Limits of Rise for determining Method of Bringing Heads to Grade

11.2.1 Rise less than 3 -1/2 inches

- 1) If the rise (R) is less than 3-1/2 use an extension unit.
- 2) If the rise (R) is 1-1/2 or more but less than 2-1/2 use an extension ring and a 1 inch cover.
- 3) If the rise (R) is 2-1/2 or more use a standard 2 inch cover.
- 4) Inlets use a standard 1-1/4 inch grate on all extension frames.

11.2.2 Rise Greater than 3-1/2 inch

- 1) If (R) is greater than 3-1/2 inches reset the head.
- 2) If the difference D-A is greater than 1/4 inch, replace the manhole frame and cover.
- 3) If the frame is spalled or cracked, replace the frame and cover.
- 4) Do not reset the head until the bottom course or courses has/have been placed and not more than 1-1/2 inches will be exposed for a period exceeding 48 hours before bringing the pavement to grade.
- 5) The brickwork will be set with a high early strength, non-shrink mortar developing a 1 hour compressive strength of 2500 PSI at 70°F. The mortar should not contain any gypsum, iron particles or chlorides e.g., Fosroc Pike-Patch as produced by Preco Industries Ltd. Plainview, NY 11803

11.3 Instructions for Non Standard Manhole Castings

If the existing frame is not a NJDOT standard unit, the following procedure will be followed:

- 1) Mark the existing manhole frame and cover with a piece of lumber crayon (keel) to insure the exact location when the cover is repositioned.
- 2) Remove the cover and measure diameter of frame in two directions, record the smaller figure.
- 3) Measure depth from top of frame to the seat in 4 quadrants, record the smallest figure.

When ordering specify the following:

- a. Original casting pattern number, if available
- b. Height of Rise (R)
- c. Diameter of existing manhole
- d. Depth of seat from top of frame

MANHOLE RESET DESIGN

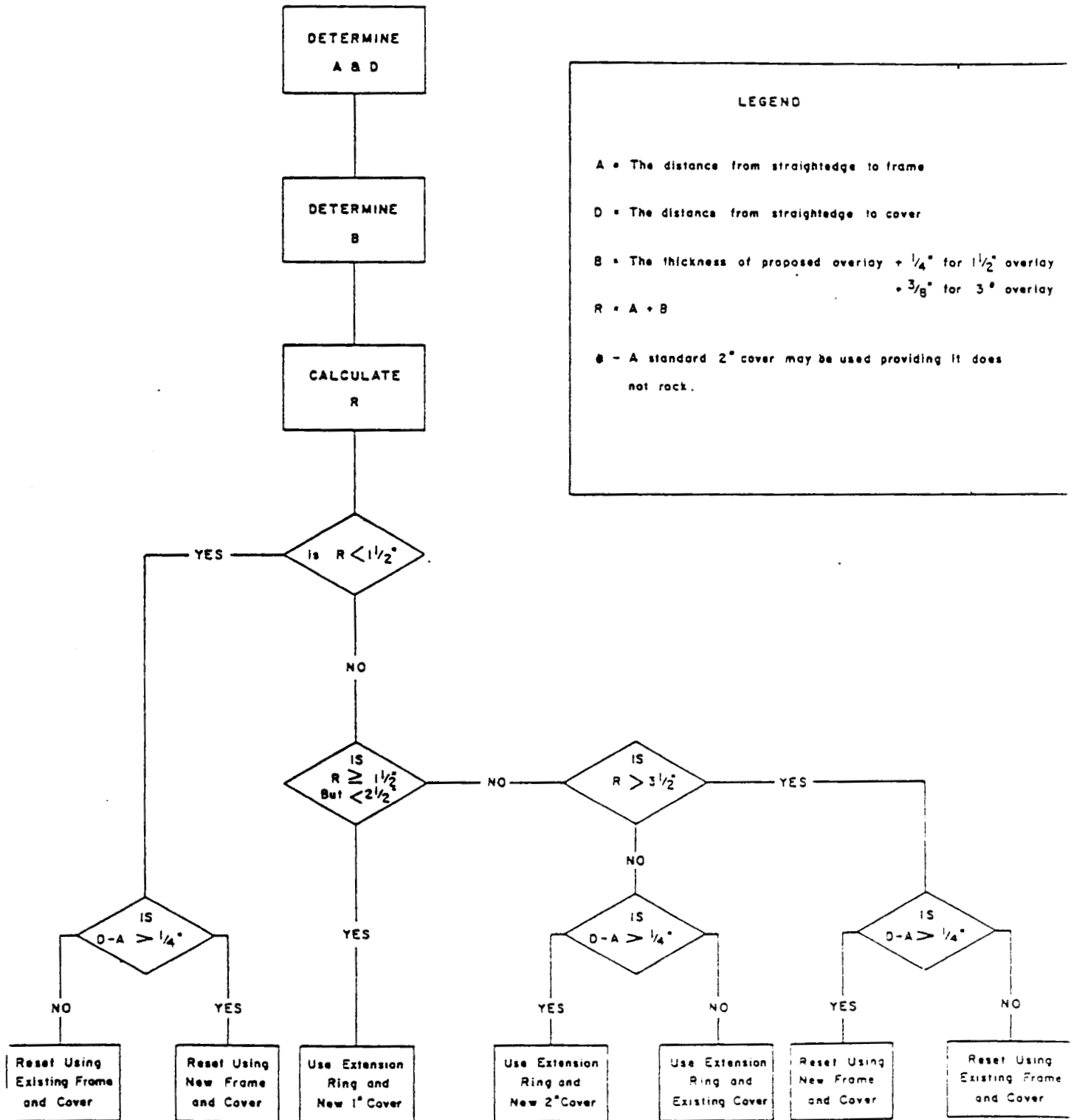

LEGEND

A = The distance from straightedge to frame

D = The distance from straightedge to cover

B = The thickness of proposed overlay + 1/4" for 1 1/2" overlay
+ 3/8" for 3" overlay

R = A + B

⊖ - A standard 2" cover may be used providing it does not rock.

APPENDIX E

PREPARING CONCRETE PAVEMENT JOINTS FOR OVERLAY

THE PROBLEM

The Department's specifications currently require that, prior to the initial overlay of a concrete pavement, all existing transverse and longitudinal joints are to be cleaned to a depth of 1" and sealed with hot-poured rubber asphalt. Any joints open to a depth greater than 1" are filled with concrete sand to within 1" of the surface and then sealed.

These joint preparation procedures were adopted prior to the Department's use of the saw and seal technique and were intended to reduce/delay the effects of reflection cracking (e.g., to minimize the inflow of surface water into the underlying pavement section through reflection cracks in the overlay).

In our view, the need for the current practice of routinely cleaning and sealing all exposed joints has been effectively eliminated by the adoption of the saw and seal technique as a standard practice. In the typical case (i.e., when the existing concrete pavement has no history of special problems), when applying the saw and seal technique, all that is needed is to selectively fill in along the joints where the joint is open or where the existing material is significantly depressed below the pavement surface. The basic rationale here is that when the saw and seal procedure is used, the only purpose of the joint pretreatment is to provide adequate support (i.e., to avoid a depression or slumping of the overlay). The sawed and sealed joint in the bituminous overlay will prevent the intrusion of water and, hence, it is not necessary to seal the underlying concrete pavement.

Adoption of the suggested change in practices to only selectively fill in joints could be expected to result in significant construction cost savings: Cleaning and sealing longitudinal and transverse joints for their full length can typically cost more than \$100,000 per project.

While we appear to be putting forth an unnecessary effort in the case of normal width joints, the reverse appears true in the case of wide joints: A special joint preparation effort is needed to achieve the full benefit of the saw and seal technique when used over existing wide joints. That is, on some of our old concrete pavements, the transverse joint opening can range up to as much as 4" in width. When the present partial depth cleaning and resealing is applied to these joints, we can expect double-line ("island") cracking to eventually occur in the overlay even when the current saw and seal procedure is applied. The problem here is that the sand/sealer base provided in the current practice simply does not possess enough strength to bridge a wide joint opening; consequently, a crack can be expected to radiate up through the overlay at the approximate location of each slab end.

What constitutes a "wide" joint for this purpose? Based on our experience and observations on a recent overlay project (Route 40 and 322), it appears that when the joint opening is 1-3/4" or more, double-line cracking occurs in at least an incipient stage within one year. To be conservative then, it would appear that any joint wider than 1-1/2" should be considered a "wide" joint, requiring some type of treatment other than simply cleaning and sealing. While we have no definitive data regarding the incidence of these so-called wide joints, it would appear that joints wider than 1-1/2" occur relatively infrequently. (Example: On

the Route 40 and 322 project — a very old, deteriorated pavement — only about 10% of the joints exceeded 1-1/2".)

RECOMMENDED PRACTICES

Pavement Cracks:

For the near term, continue the present practice of simply sealing existing cracks. (As a result of work on our second generation overlay study, we may in the future be making recommendations regarding an alternate treatment for pavement cracks.)

Normal Width Joints (Openings of up to 1-1/2"):

Discontinue the current practice of routinely cleaning and sealing the full length of longitudinal and transverse joints and instead selectively reseal as follows:

A. Transverse Joints:

1. If the existing joint space is filled to within 1/2" of the surface of the existing concrete pavement by filler board, sealer, and/or any other material, no additional treatment is to be applied.
2. When the existing material in the joint space is depressed from 1/2" to 1" below the surface of the concrete pavement, reseal with hot-poured rubber asphalt to the level of the pavement surface.
3. When the material in the joint is more than 1" below the surface of the pavement, and contains the remnants of a filler board, sealer and/or any other material, fill the joint opening with sand to within 1" of the surface and reseal the remaining depth with hot-poured rubber asphalt.
4. If the joint is essentially open (i.e., little or no filler board or other material), clean the joint as necessary to install a new bituminous impregnated fiber board for the full depth of the pavement (with necessary cutouts for dowels). NOTE: Two filler boards of appropriate thickness could be tacked together to fill the joint space where needed; it is not necessary to completely fill the full width of the joint.

B. Longitudinal Joints:

1. In any case involving tied longitudinal joints, no joint pretreatment is necessary prior to overlay.
2. If the existing joint is of the formed type with a filler board, fill/seal as in the case of transverse joints. (NOTE: If a significant longitudinal joint separation has occurred, treat the same as for "wide" transverse joints, as described below.)

Wide Joints (Openings of greater than 1-1/2"):

Clean out the joint space to a minimum depth of 3", fill with a fine (I-5) bituminous mix, and compact.

APPENDIX F

..... 40400 SSJTBCO

SAWING AND SEALING OF JOINTS IN BITUMINOUS CONCRETE OVERLAY

H
H
H
H

DESCRIPTION.

THIS WORK SHALL CONSIST OF MAKING SAW CUTS IN BITUMINOUS CONCRETE OVERLAY DIRECTLY OVER EXISTING TRANSVERSE, LONGITUDINAL AND EDGE JOINTS OF THE UNDERLYING CONCRETE, OR WHERE DIRECTED, AND THE SEALING OF EACH COMPLETED SAW CUT.

MATERIALS.

JOINT SEALER SHALL BE HOT-POURED RUBBER ASPHALT CONFORMING TO SUBSECTION 908.02.

EQUIPMENT.

EQUIPMENT SHALL CONSIST OF A COMBINED MELTER AND PRESSURE APPLICATOR. APPLICATOR SHALL BE EITHER OIL OR GAS FIRED, DOUBLE WALLED, OIL-BATH TYPE WITH POWER-DRIVEN MECHANICAL AGITATOR AND CIRCULATING PUMP. THE MELTER SHALL BE EQUIPPED WITH A THERMOSTAT TO MAINTAIN THE SEALING COMPOUND WITHIN THE TEMPERATURE RANGE SPECIFIED BY THE MANUFACTURER AND WITH A THERMOMETER SO LOCATED TO INDICATE THE TEMPERATURE OF THE SEALING COMPOUND.

EQUIPMENT USED FOR DISPENSING THE MATERIAL SHALL BE A WAND TYPE APPLICATOR AND SHALL HAVE A WING GUIDE ATTACHED TO THE TIP TO FACILITATE TRACING THE SAWED JOINT. THE FLOW CONTROL VALVE SHALL BE NOT MORE THAN 6 INCHES FROM THE TIP. A 2-INCH STUB THERMOMETER SHALL BE SUITABLY MOUNTED BETWEEN THE FLOW VALVE AND THE TIP TO INDICATE THE TEMPERATURE OF THE SEALING COMPOUND.

CONSTRUCTION REQUIREMENTS.

JOINTS SHALL BE CONSTRUCTED AFTER THE BITUMINOUS CONCRETE OVERLAY HAS AGED SUFFICIENTLY TO ALLOW A CLEAN CUT TO BE MADE AND TO WITHSTAND THE TEARING EFFECTS OF THE SAW. THIS AGING PERIOD SHALL NOT EXCEED FIVE DAYS.

SAW CUTS SHALL BE MADE IN A STRAIGHT LINE WITH A POWER-DRIVEN SAW, AND SHALL BE CUT TO THE DIMENSIONS IN FIGURE F-1. THE CUT SHALL BE SAWED WET, THE GROOVE SHALL BE WASHED FREE OF PARTICLES AND AIR BLOWN TO DRYNESS.

CLEANING OF THE SAWED JOINTS, PRIOR TO SEALING, SHALL BE PERFORMED BY BLOWING OUT DIRT, DUST OR DELETERIOUS MATTER THAT MAY HAVE ACCUMULATED.

SAWED JOINTS SHALL BE SEALED IMMEDIATELY AFTER THE GROOVE HAS BEEN BLOWN DRY. TRAFFIC SHALL NOT BE PERMITTED TO KNEAD OR DAMAGE THE JOINT.

THE HOT SEALER SHALL COMPLETELY FILL THE JOINT SO THAT, AFTER COOLING, THE LEVEL OF THE SEALER SHALL BE NOT GREATER THAN 1/8 INCH BELOW THE SURFACE. THE RATE OF SEALING WILL BE SUCH AS TO ELIMINATE ALL VOIDS OR ENTRAPPED AIR AND NOT LEAVE ANY UNNECESSARY SURPLUS JOINT SEALER ON THE BITUMINOUS SURFACE. ANY DEPRESSION GREATER THAN 1/8 INCH SHALL BE BROUGHT TO THE SPECIFIED LIMIT BY FURTHER ADDITION OF THE SEALER.

EXCESS OR SPILLED SEALER SHALL BE REMOVED FROM THE BITUMINOUS SURFACE.

METHOD OF MEASUREMENT.

SAWING AND SEALING OF JOINTS IN BITUMINOUS CONCRETE OVERLAY WILL BE MEASURED BY THE LINEAR FOOT.

BASIS OF PAYMENT.

PAYMENT WILL BE MADE UNDER:

<u>PAY ITEM</u>	<u>PAY UNIT</u>
SAWING AND SEALING OF JOINTS IN BITUMINOUS CONCRETE OVERLAY	LINEAR FOOT

*****END*****

H
H

FIGURE F-1

DETAILS FOR TRANSVERSE SAWING AND SEALING IN ASPHALT CONCRETE OVERLAYS

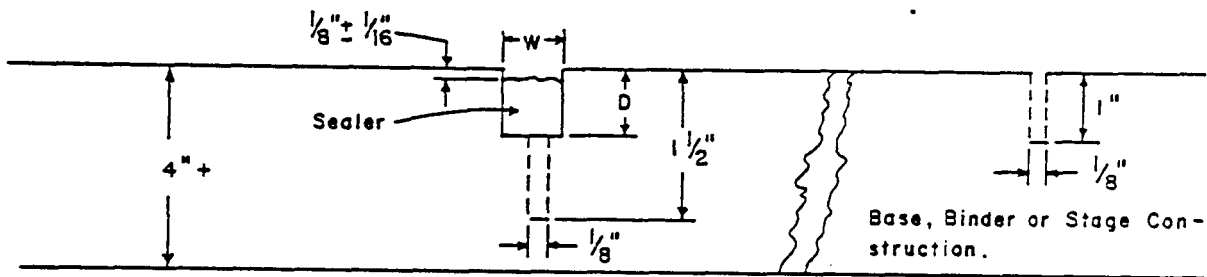

For first generation overlays up to 3½" thick, the W/D ratio will be 1/2" x 5/8". For first generation overlays above 4", the W/D ratio will be 3/8" x 5/8", however, a 1/8" x 1-1/2" sawcut shall precede the 3/8" x 5/8" cut for the sealant reservoir. In the event that the surface course is not placed within five days of placement of the base, binder or leveling course, this will be considered as stage construction and must have a 1/8" x 1" sawcut over all transverse joints over the underlying concrete slab. This 1/8" x 1" sawcut does not require sealing. Any reflection cracking occurring prior to the sawing and sealing operation will be cut with a random saw.

For second generation overlays up to 3-1/2" thick, the W/D ratio will be 3/8" x 5/8". A separate saw cut shall be made in the overlay at the bituminous slab interface of all full-depth patches.

All longitudinal and edge joints, regardless of thickness, will use the W/D ratio of 3/8" x 5/8".