

# **SIGNS ON BREAKAWAY BARRICADES WIND AND CRASH TESTS**

**FINAL REPORT**

by

**Thomas D. Davis**

**Principal Engineer**



Prepared by  
New Jersey Department of Transportation  
Division of Research and Demonstration  
1035 Parkway Avenue  
Trenton, NJ 08625

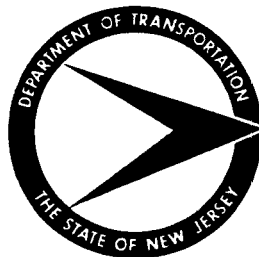

In Cooperation With  
U.S. Department of Transportation  
Federal Highway Administration

1. Report No. FHWA NJ 90-007		2. Government Accession No.		3. Recipient's Catalog No.	
4. Title and Subtitle Signs on Breakaway Barricades - Wind and Crash Tests				5. Report Date August 1990	
				6. Performing Organization Code	
7. Author(s) Thomas D. Davis, Phone: (609)292-4718				8. Performing Organization Report No. 90-007-7410	
9. Performing Organization Name and Address New Jersey Department of Transportation Division of Research and Demonstration 1035 Parkway Avenue, CN 600 Trenton, NJ 08625				10. Work Unit No. (TRAIS)	
				11. Contract or Grant No. HPR Res. Study No.7410	
12. Sponsoring Agency Name and Address Federal Highway Administration U.S. Department of Transportation Washington, DC 20418				13. Type of Report and Period Covered Final Report	
				14. Sponsoring Agency Code	
15. Supplementary Notes					
16. Abstract Work zone informational sign panels are often mounted on portable wood or metal frames and used for changing traffic operations in New Jersey work zones. At times, these portable signs are placed close to Type III breakaway barricades used to channelize traffic. If signs could be placed on the barricades instead, then some portable wood or metal sign frames would no longer be needed. This would reduce sign costs as well. Barricades with signs attached at various heights for visibility purposes were tested for durability under wind loads up to 60 mph in accordance with criteria established by the American Association of State Highway and Transportation Officials (AASHTO). Twenty and 60 mph full scale vehicle crash tests were conducted in compliance with criteria found in AASHTO and the National Cooperative Highway Research Program Report 230. Only lightweight signs were attached to the barricades in the tests to eliminate doubt concerning the damage that standard weight signs might cause. The 0.024 inch thick aluminum sign with 12 inches of ground clearance failed the 60 mph crash test. However, vinyl rollup signs with 38 and 50 inches of clearance and 0.024 inch thick aluminum signs with 29 and 41 inches of clearance from the bottom of the sign to the pavement passed the wind and crash tests and are recommended for implementation.					
17. Key Words Type III breakaway barricades, portable signs, work zones, wind tests, crash tests			18. Distribution Statement		
19. Security Classif. (of this report) Unclassified		20. Security Classif. (of this page) Unclassified		21. No. of Pages	22. Price

## TABLE OF CONTENTS

	<u>Page</u>
List of Tables	ii
List of Figures	iii
Acknowledgments	iv
Summary and Conclusions	1
Recommendations	1
Implementation of Findings	1
Introduction	2
Problem	2
Background	2
Objective	3
Procedure	3
Description	4
Barricade	4
Sign	4
Wind Tests - Phase 1	5
Wind Tests - Phase 2	6
Wind Tests - Phase 3	8
Preliminary Crash Tests	10
Final Crash Tests	11
Discussion	14
References	15
Appendices	16
A. Wind Tests	17
B. Preliminary Crash Tests	27

LIST OF TABLES

	<u>Page</u>
1. Results of Phase 1 Wind Tests	6
2. Results of Phase 2 wind Test	7
3. Results of Phase 3 Wind Tests	9
4. Results of Preliminary Crash Tests	11
5. Results of Final Crash Tests	13

LIST OF FIGURES

	<u>Page</u>
1. Phase 1 Wind Test with 1 ft. Clearance Aluminum Sign.	18
2. Phase 1 Wind Test with 7 ft. Clearance Vinyl Sign.	18
3. Phase 2 Wind Test with 1 ft. Clearance Vinyl Sign.	19
4. Phase 2 Wind Test with 5 ft. Clearance Vinyl Sign.	19
5. Phase 2 Wind Test with 7 ft. Clearance Aluminum Sign.	20
6. Aluminum Sign on Barricade with 12 in. of Clearance.	21
7. Aluminum Sign on Barricade with 29 in. of Clearance.	22
8. Aluminum Sign on Barricade with 41 in. of Clearance.	23
9. Vinyl Sign on Barricade with 21 in. of Clearance	24
10. Vinyl Sign on Barricade with 38 in. of Clearance.	25
11. Vinyl Sign on Barricade with 50 in. of Clearance.	26
12. Preliminary Crash Test Vehicle Guidance System.	28
13. Preliminary Crash Test Vehicle.	28
14. Typical Preliminary Crash Test Vehicle Damage.	29
15. Preliminary Crash Test Windsheild Damage from 41 in. Clearance Aluminum Sign.	29

### ACKNOWLEDGMENTS

This research was done in cooperation with the FHWA, U.S. Department of Transportation. Appreciation is expressed to: Charles A. Goessel of NJDOT's Design Division for originating the idea of using signs on breakaway barricades; Eugene F. Reilly, Richard L. Hollinger, and Arthur W. Roberts for their administrative assistance; Lad Szalaj, Bill Crowell, Bob Tomlinson, John Senyk, Zolton Zeisky and Tom Black for their technical assistance; the Technical Committee members for their valuable input; Judith Scymanski and Yolanda Prilo for typing the final report. The FAA Tech Center for the use of the jet exhaust wind tunnel; the University of Nebraska for performing the final crash tests; the Bureau of Transportation Technology Research for video taping the wind and preliminary crash tests; the Division of Maintenance for providing the trucks used in the wind tests; and finally MDI Traffic Control Products, a Division of Marketing Displays, Inc. for providing vinyl rollup signs and Windmaster sign holders for testing.

SUMMARY AND CONCLUSIONS

Based on the results of the 60 mph wind tests and the 20 mph and 60 mph crash tests, the following meet AASHTO and NCHRP criteria for 4 ft. by 4 ft. vinyl and 0.024 inch aluminum signs attached to type III breakaway barricades:

1. 29 inch clearance 0.024 inch thick aluminum sign.
2. 38 inch clearance vinyl rollup sign.
3. 41 inch clearance 0.024 inch thick aluminum sign.
4. 50 inch clearance vinyl rollup sign.

The signs were reusable and the barricade frames could be repaired with available interchangeable parts. Type III breakaway barricades with attached four foot by four foot signs continued to function in a manner consistent with standard Type III breakaway barricades. This means that wood or metal frames will no longer be needed to support signs in the vicinity of existing Type III breakaway barricades. This in turn means fewer fixed objects and lower costs.

RECOMMENDATIONS

Vinyl rollup signs with 38 and 50 inches of clearance and 0.024 inch thick aluminum signs with 29 and 41 inches of clearance from the bottom of the sign to the pavement are recommended for installation in work zones.

IMPLEMENTATION OF FINDINGS

Starting in November, 1989, the 50 inch clearance vinyl rollup signs were used in actual workzones and in June, 1990 the 0.024 inch thick aluminum signs with 41 inches of clearance were

installed on an interstate highway. The 29 and 38 inch clearance models will be implemented as needed. The signs were monitored and functioned as they should.

## INTRODUCTION

### Problem

Work zone informational sign panels are often mounted on portable wood or metal frames and used for changing traffic operations in New Jersey work zones. At times, these portable diamond shaped signs are placed close to barricades used to channelize traffic. If signs could be placed on the breakaway barricades instead, then the practice of using portable wood or metal sign frames could be abandoned. This would reduce the number of hazardous objects near traffic. This is timely because most work zone accidents are collisions with hazardous objects (1). The sign expenses would be reduced as well.

### Background

The barricades used to channelize traffic are called Type III breakaway barricades. They have three lightweight horizontal panels with orange and white stripes. The barricades are made of unglued 3 inch diameter polyvinyl chloride (PVC) pipe and have been shown to cause minimal damage to vehicles on impact (2,3). In order to eliminate doubt concerning causes of damage from the tests, only lightweight signs were attached to the barricades.

The Manual on Uniform Traffic Control Devices (4) allows work zone signs on barricades as long as the bottom of the sign is at least a foot above the pavement, although higher mounting heights are desirable. So, efforts were made to attach the four

foot square sign panels as high as possible to provide good visibility to drivers, and the barricades were modified to support the signs at higher positions.

An initial search of the Transportation Research Information Service on line computer files generated no abstracts relevant to signs on Type III breakaway barricades. A second search was made on the broader subject of temporary or portable barricades or barriers with breakaway or frangible features. One hundred and thirty abstracts were produced. No information was found relative to testing of portable small sign supports, including signs on Type III breakaway barricades. A search of related information sources yielded only one untested prototype Type III breakaway barricades sign support which was developed by the Ponca City, Oklahoma Traffic Engineering Department.

#### Objective

The barricades with attached signs were to continue to function in a manner consistent with standard PVC Type III breakaway barricades when subjected to wind stress as specified by the American Association of State Highway and Transportation Officials (AASHTO) and vehicle impacts in compliance with criteria established by AASHTO and the National Cooperative Highway Research Program (NCHRP) Report 230.

#### Procedure

To select an adequate barricade supported sign device, the following procedures were used:

1. preliminary wind load tests using the back of a moving truck,

2. intermediate wind load tests using a jet exhaust wind tunnel,
3. final wind load tests using the back of a moving truck,
4. preliminary in-house crash tests at low speeds and
5. high speed crash tests by a contractor.

The sign height was varied during the tests, and modifications were made as necessary. The design that passed the tests will be installed and monitored in an actual work zone.

#### DESCRIPTION

##### Barricade

Type III breakaway barricades were used to support the necessary sign panels. The barricades have three 9 inch by 48 inch 0.024 inch thick aluminum horizontal panels with orange and white stripes. The panels are attached to 3 inch unglued poly vinyl chloride (PVC) pipe schedule 40 ASTM 1785-74 or SDR-26 ASTM 2241-74. Two spring tensioned wires from the top to the base of the frame keep the barricade from vibrating apart. To restrain the upper horizontal panel from impacting car windshields upon impact, a #6, 3/16-inch diameter solid braided nylon rope is placed inside the vertical portion of the barricade frame and tied to form a loop. For ballast, a total of 300 lbs. of sand bags are placed on the frame base to resist wind loads. See Appendix A for details.

##### Sign

The diamond shaped signs were 4 feet long on each side and made of either vinyl or 0.024 inch thick aluminum. The vinyl

sign was supplied with a fiberglass cross that provided rigidity and was attached to the barricade with two 1 inch number 14 pan head screws through the horizontal fiberglass cross member; the aluminum sign was attached to the barricade with four, 1 inch number 14 pan head screws.

### WIND TESTS-PHASE 1

#### Method

On October 2, 1986 a flatbed stake truck was used to test the effects of wind on the experimental sign on barricade devices. The signs were placed on the tailgate to minimize the effects of the truck cab. The signs with 1 ft. of clearance from the bottom of the sign to the pavement were attached to standard type III breakaway barricades; the 5 ft. clearance signs were attached to barricades extended upward; the 7 ft. clearance sign was attached to a barricade with an extended height and an extended base. To pass this preliminary screening, the signs and barricades were to keep their integrity as the truck accelerated. While the goal was 60 mph, the truck in reality reached a maximum speed of 50 mph due to the shortness of the test track. Each model was tested for wind stress into and behind the sign by reversing the orientation of the sign. See Appendix A for details.

#### Results

Table 1 outlines the results of the phase 1 truck tests. There were no problems with the 1 ft. clearance signs. However, both aluminum and vinyl 5 ft. clearance and the vinyl 7 ft. clearance signs failed when the top extension broke free from the barricade. While the 0.024 in. aluminum sign flexed in the wind, it straightened out after the test.

At this point the 5 ft. and 7 ft. clearance sign frames were adjusted. This time the 5 ft. clearance frame was extended both vertically and horizontally, and the 7 ft. clearance sign frame was designed so that a second set of two spring tensioned wires would accept most of the wind load. These new designs were tested in the next wind test.

TABLE 1. RESULTS OF PHASE 1 WIND TESTS

<u>Test Number</u>	<u>Sign Materials</u>	<u>Sign Clearance (ft.)</u>	<u>Ballast (lbs.)</u>	<u>Wind Direction</u>	<u>Results*</u>
1	aluminum	1	300	behind sign	pass
2	aluminum	1	300	into sign	pass
3	vinyl	1	300	behind sign	pass
4	vinyl	1	300	into sign	pass
5	aluminum	5	600	behind sign	fail, 45 mph
6	aluminum	5	600	into sign	fail, 40 mph
7	vinyl	5	600	behind sign	fail, 40 mph
8	vinyl	5	600	into sign	pass
9	vinyl	7	600	behind sign	fail, 45 mph
10	vinyl	7	600	into sign	fail, 45 mph

\* To pass, the sign and barricade were to keep their integrity when subject to a wind load of 50 mph.

WIND TESTS-PHASE 2

Method

On October 27, 1986, the 1 ft. clearance models and the modified 5 ft. and 7 ft. clearance models were tested at the

Federal Aviation Administration Technical Center jet exhaust wind tunnel facility in Atlantic City New Jersey. According to AASHTO (5), "Roadside sign structures that are considered to have a relatively short life expectancy may be designed using wind speeds based on a 10-year mean recurrence interval." For New Jersey, a 10-year wind is 60 mph. Thus the sign and support structures would have to keep their integrity under a 60 mph load to pass the wind tunnel test. While the 1,5 and 7 ft. models were tested in both directions, only the 5 ft. model was tested with both the aluminum and the vinyl signs. Phase 1 showed little difference between the aluminum and vinyl signs with the same clearance. See Appendix A for details

Results

As Table 2 shows, the 1 ft. clearance vinyl sign passed this wind test as well. While the 5 ft. clearance vinyl sign endured the test, the aluminum sign failed when the frame separated with the wind into the sign. The 7 ft. clearance aluminum sign frame failed when the top "Y" fitting fractured.

TABLE 2. RESULTS OF PHASE 2 WIND TESTS

<u>Test Number</u>	<u>Sign Materials</u>	<u>Sign Clearance (ft.)</u>	<u>Ballast (lbs.)</u>	<u>Wind Direction</u>	<u>Results*</u>
1	vinyl	1	300	behind sign	pass
2	vinyl	1	300	into sign	pass
3	aluminum	5	300	behind sign	pass
4	aluminum	5	300	into sign	fail, 40 mp.
5	vinyl	5	300	behind sign	pass
6	vinyl	5	300	into sign	pass
7	aluminum	7	300	into sign	fail, 46 mp.

\* To pass, the sign and barricade were to keep their integrity when subjected to a wind load of 60 mph.

Based on the results of the wind tunnel tests, more changes were made to make the sign frames more durable. The springs that provided tension for the wires used on the standard barricade were removed since they allowed too much flexing under wind loads. The springs were also judged to be a hazard to workers since they tended to come loose and become projectiles when adjusted by workers. The wires were pulled tight to provide tension. The aluminum sign clearances were reduced to 12, 29 and 41 inches, and the vinyl sign clearances were reduced to 21, 38 and 50 inches. The 29 and 38 inch clearance signs were attached to barricades extended up 1 ft., and the 41 and 50 inch clearance signs were attached to barricades extended up 2 ft. The vinyl signs were 9 inches higher than the aluminum signs because the vinyl signs had their own support system. See Appendix A for details.

### WIND TESTS-PHASE 3

#### Method

The new sign on barricade designs were placed on a flatbed stake truck that reached 60 mph. As usual, the signs were tested with the wind behind the sign and into the sign.

#### Results

All of the redesigned sign on barricade structures passed this final wind test (Table 3). The signs were now ready for the preliminary crash tests.

TABLE 3. RESULTS OF PHASE 3 WIND TESTS

<u>Test Number</u>	<u>Sign Material</u>	<u>Sign Clearance (in.)</u>	<u>Ballast (lbs.)</u>	<u>Wind Direction</u>	<u>Results*</u>
1	aluminum	12	300	behind sign	pass
2	aluminum	12	300	into sign	pass
3	aluminum	29	400	behind sign	pass
4	aluminum	29	400	into sign	pass
5	aluminum	41	400	behind sign	pass
6	aluminum	41	400	into sign	pass
7	vinyl	21	300	behind sign	pass
8	vinyl	21	300	into sign	pass
9	vinyl	38	400	behind sign	pass
10	vinyl	38	400	into sign	pass
11	vinyl	50	400	behind sign	pass
12	vinyl	50	400	into sign	pass

\* To pass, the sign and barricade were to keep their integrity when subjected to a wind load of 60 mph.

## PRELIMINARY CRASH TESTS

### Method

On July 15, 1987, the barricades with attached signs were crash tested to determine their effects on vehicles and nearby workers. An unoccupied Plymouth Horizon was used to crash into the signs at 25 mph, the highest speed possible under the test track conditions. 150 ft. of "W" beam guardrail was used to guide the vehicle to the sign and a truck was used to push the car down the track. Once the car reached 25 mph, the truck driver braked and the car continued into the sign. After the collision, the car was stopped with a remotely controlled hydraulic brake. The tests were documented with two video cameras and one 35 mm camera. One video camera was positioned to view the entire site, and the other video camera recorded the actual impact. The preliminary test was done in-house and was designed to eliminate unsafe models prior to final testing by a contractor. See Appendix B for details

### Results

As Table 4 shows, the six crashes, with the exception of one, did only cosmetic damage to the car. However, the 41 in. clearance aluminum sign did damage the windshield. The right post was hit and the upper right section of the barricade structure shattered the windshield. In this case, the internal rope failed to hold the vertical portion of the barricade together, permitting the debris to hit the windshield. The internal rope was used in the standard barricade to keep the top portion of the barricade away from the windshield. To minimize

Table 4. RESULTS OF PRELIMINARY CRASH TESTS

<u>Test Number</u>	<u>Sign Material</u>	<u>Sign Clearance(in.)</u>	<u>Ballast (lbs.)</u>	<u>Number of Posts Hit</u>	<u>Results</u>
1	aluminum	12	300	1	small dent in hood
2	aluminum	29	400	2	small dent in hood
3	aluminum	41	400	1	windshield cracked
4	vinyl	21	300	2	small dent in hood
5	vinyl	38	400	2	small dent in hood
6	vinyl	50	400	2	small dent in hood

this problem, the sign panel was attached above the top "T" fitting. Also, the two external tension wires were specified to be 12 gage (the original barricade wire gage was unspecified). In this way the sign and frame should separate above the "T" fitting and clear the top of the vehicle. The internal rope should keep the rest of the frame away from the windshield. In all of the tests the signs did not become missiles to harm other drivers or nearby workers. The sign either stayed with the vehicle or landed a few feet from the impact site. With these minor adjustments made, the signs were ready for the final crash tests.

FINAL CRASH TESTS

Method

In the fall of 1988, the University of Nebraska (6) conducted 20 and 60 mph crash tests using a 1800 pound unoccupied 1980 Volkswagon Rabbit. Two piezoresistive

accelerometer were bolted to the car floor to measure longitudinal accelerations; two 16 mm cameras documented the collisions at 500 frames per second; and tape pressure switches measured the speed before and after impact. The Rabbit was towed by another vehicle, was guided by a suspended cable and was released prior to impact.

### Criteria

The test performance was judged based on criteria set by AASHTO (5) and NCHRP (7). The purpose of the 20 mph test was to measure the breakaway characteristics of the signs and their barricade support. On impact the center of the bumper was planned to be midway between the two barricade posts. The purpose of the 60 mph test was to estimate vehicle stability, vehicle trajectory, occupant risk, debris intrusion into the passenger compartment and the hazard from debris to the other traffic. The right post was contacted by the quarter point of the vehicle's bumper. The 21 inch clearance vinyl sign was not tested because it was so much like the standard barricade which was already crash tested over fifteen years ago. On the other hand, the 41 inch clearance aluminum sign was also impacted at 20 mph and 60 mph with the bumper centered on one post due to the windshield cracking experienced in the preliminary tests.

### Results

Table 5 lists the results of the 12 full scale crash tests into the experimental barricade supported signs. The values for

TABLE 5. RESULTS OF FINAL CRASH TESTS

<u>Test Number</u>	<u>Sign Material</u>	<u>Sign Clearance(in.)</u>	<u>Speed (mph)</u>	<u>Ballast (lb.)</u>	<u>Number of Posts Hit</u>	<u>Results*</u>
1	aluminum	12	20	300	2	pass
2	aluminum	12	60	300	2	fail
3	aluminum	29	20	400	2	pass
4	aluminum	29	60	400	2	marginal
5	aluminum	41	20	400	2	pass
6	aluminum	41	60	400	2	pass
7	aluminum	41	20	400	1	pass
8	aluminum	41	60	400	1	pass
9	vinyl	38	20	400	2	pass
10	vinyl	38	60	400	2	pass
11	vinyl	50	20	400	2	pass
12	vinyl	50	60	400	2	pass

\* To pass, the barricade supported sign structures must have met NCHRP and AASHTO criteria for:

- a. debris intrusion into the passenger compartment,
- b. hazard to other traffic from debris,
- c. passenger compartment integrity,
- d. vehicle velocity change (not to exceed 15 fps),
- e. vehicle stability,
- f. vehicle trajectory,
- g. occupant impact velocity (not to exceed 15 fps) and
- h. occupant ride down acceleration (not to exceed 15 g's)

the vehicle impact velocity, the vehicle change in velocity and the occupant impact velocity were all normalized to give values that would be more indicative of the test results had the tests been conducted at the exact target impact speed. The following can be noted :

1. Three of the devices proved satisfactory in meeting the criteria, namely,
  - a. the 41" clearance aluminum sign on an extended barricade,
  - b. the 38" clearance vinyl sign on an extended barricade, and
  - c. the 50" clearance vinyl sign on an extended barricade.
2. The 29" clearance aluminum sign on an extended barricade proved to be marginal because high occupant impact velocities (17.4 fps) and vehicle velocity changes (16.9 fps) were recorded.
3. The 12" clearance aluminum sign on a standard barricade failed the criteria because the sign and support structure intruded into the passenger compartment.

#### DISCUSSION

Although the 29 inch clearance 0.024 inch thick aluminum sign was marginal in passing the 60 mph crash test, the University of Nebraska said "this design has the ability to perform satisfactorily provided that it is ballasted properly." It is important that the sand bags be distributed evenly along the base of the barricade since they tend to pile up under the car.

REFERENCES

1. Harris, Donald C., "Steps Toward Stopping The Slaughter in The Work Zone," Traffic Safety, July August 1987.
2. Miller, A. S., "Breakaway Barricades," Public Roads, Vol. 40, No. 1, 1976.
3. Federal Highway Administration, "Breakaway Barricades," Demonstration Project No. 41, 1978.
4. "Manual on Uniform Traffic Control Devices," U.S. Department of Transportation, Federal Highway Administration, 1988.
5. "Standard Specifications for Structural Supports for Highway Signs, Luminaires, and Traffic Signals," American Association of State Highway and Transportation Officials, 1985.
6. Magdaleno, John A., Faller, Ronald K. and Post, Edward R., "Full-Scale Vehicular Crash Testing of Experimental Signs on Barricade Structures," University of Nebraska-Lincoln, Civil Engineering department, June, 1989. Unpublished report prepared for NJDOT.
7. NCHRP 230 Report, "Recommended Procedures for Safety Performance Evaluation of Highway Appurtenances," National Cooperative Highway Research Program Report, Transportation Research Board, March, 1981.

APPENDICES

**Appendix A. Wind Tests**

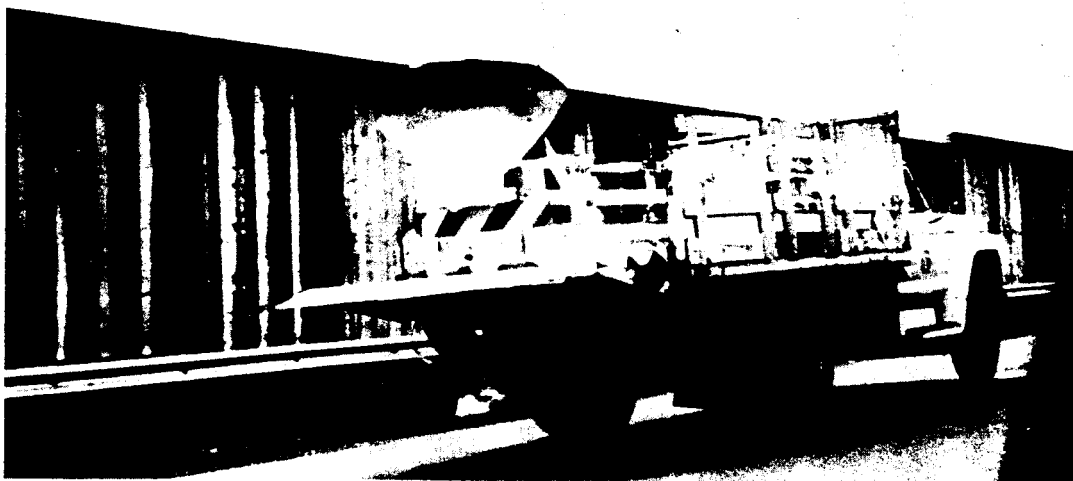

Figure 1. Phase 1 Wind Test with 1 ft. Clearance Aluminum Sign at 50 mph

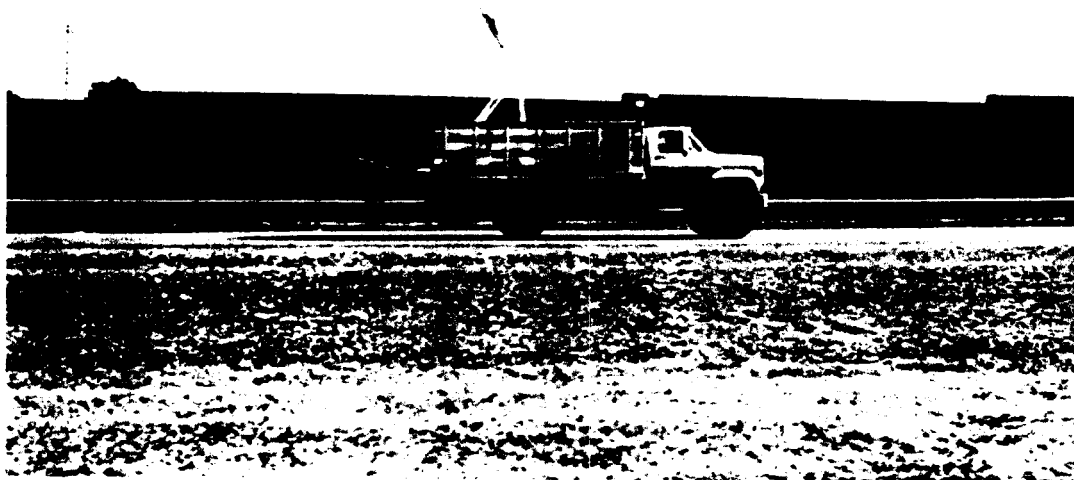

Figure 2. Phase 1 Wind Test with 7 ft. Clearance Vinyl Sign at 45 mph

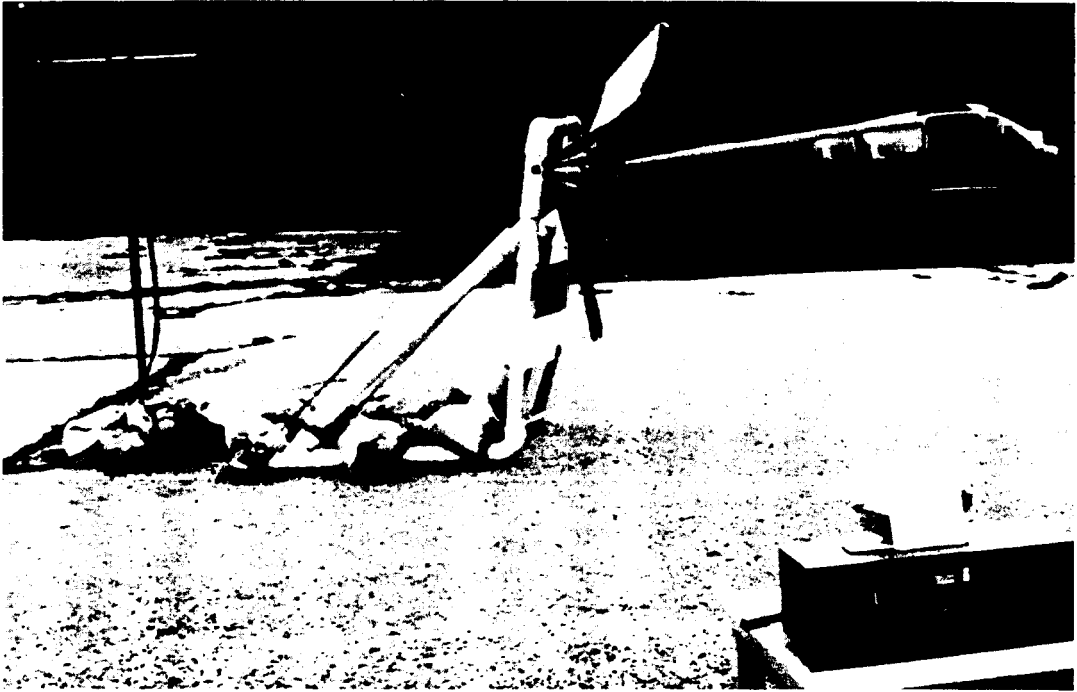

Figure 3. Phase 2 Wind Test with 1 ft. Clearance Vinyl Sign at 69 mph.

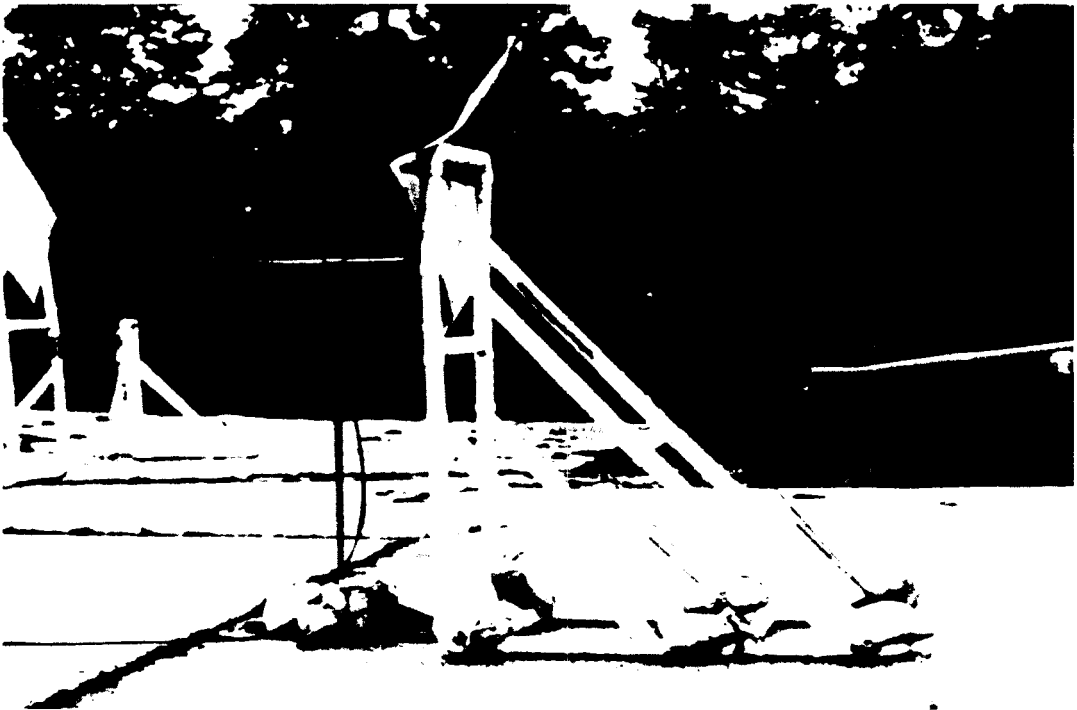

Figure 4. Phase 2 Wind Test with 5 ft. Clearance Vinyl Sign at 63 mph.

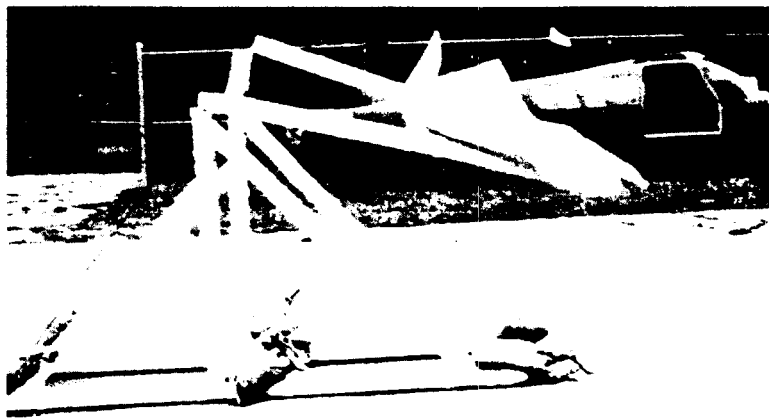
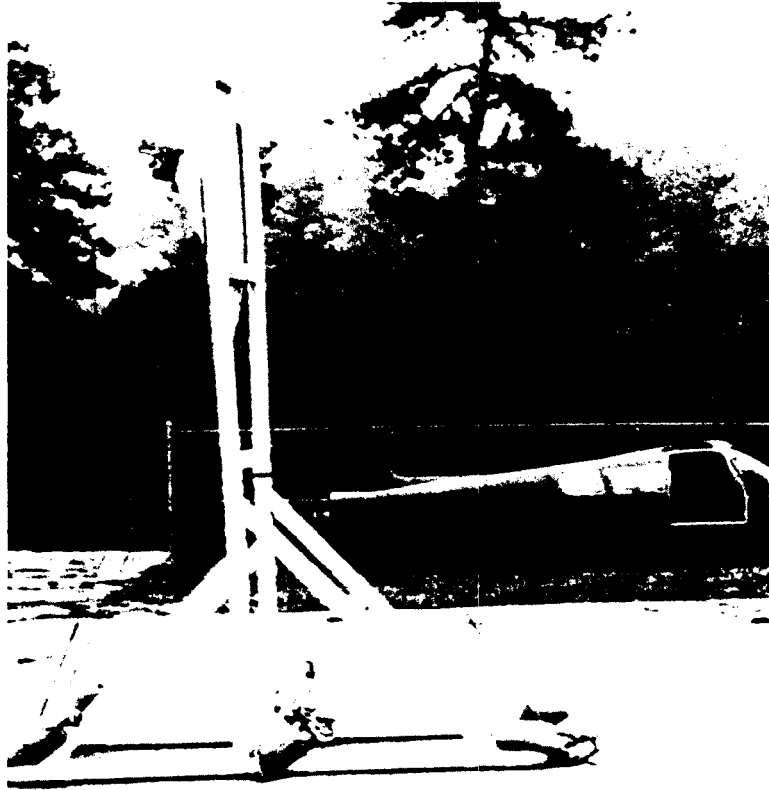
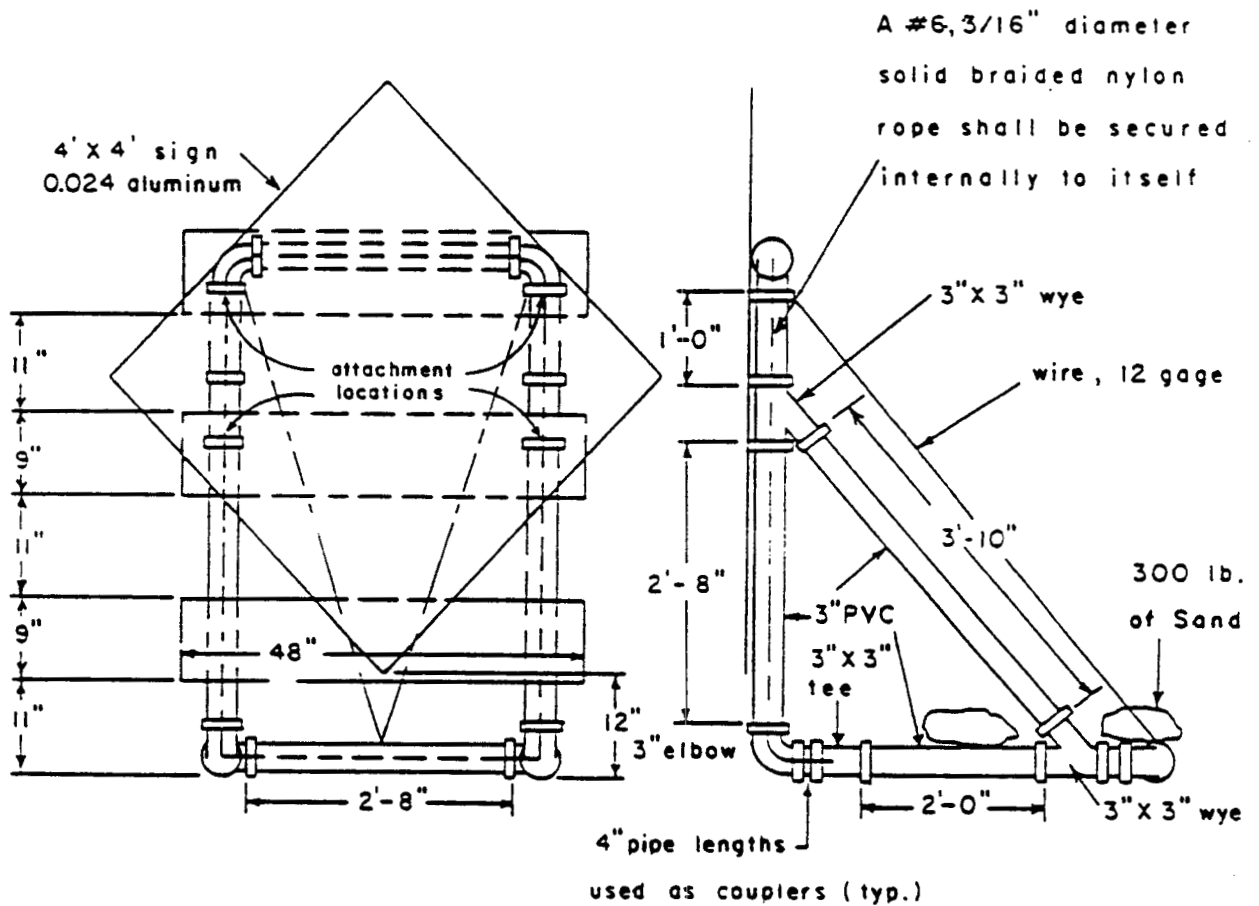

Figure 5. Phase 2 Wind Test with 7 ft. Clearance Aluminum Sign at 46 mph.

FIGURE 6. ALUMINUM SIGN ON BARRICADE WITH 12" OF CLEARANCE





# FIGURE 8. ALUMINUM SIGN ON BARRICADE WITH 41" OF CLEARANCE

**NOTE:**

All dimensions on full pipe length.

Socket depth of fittings is 1 1/2".

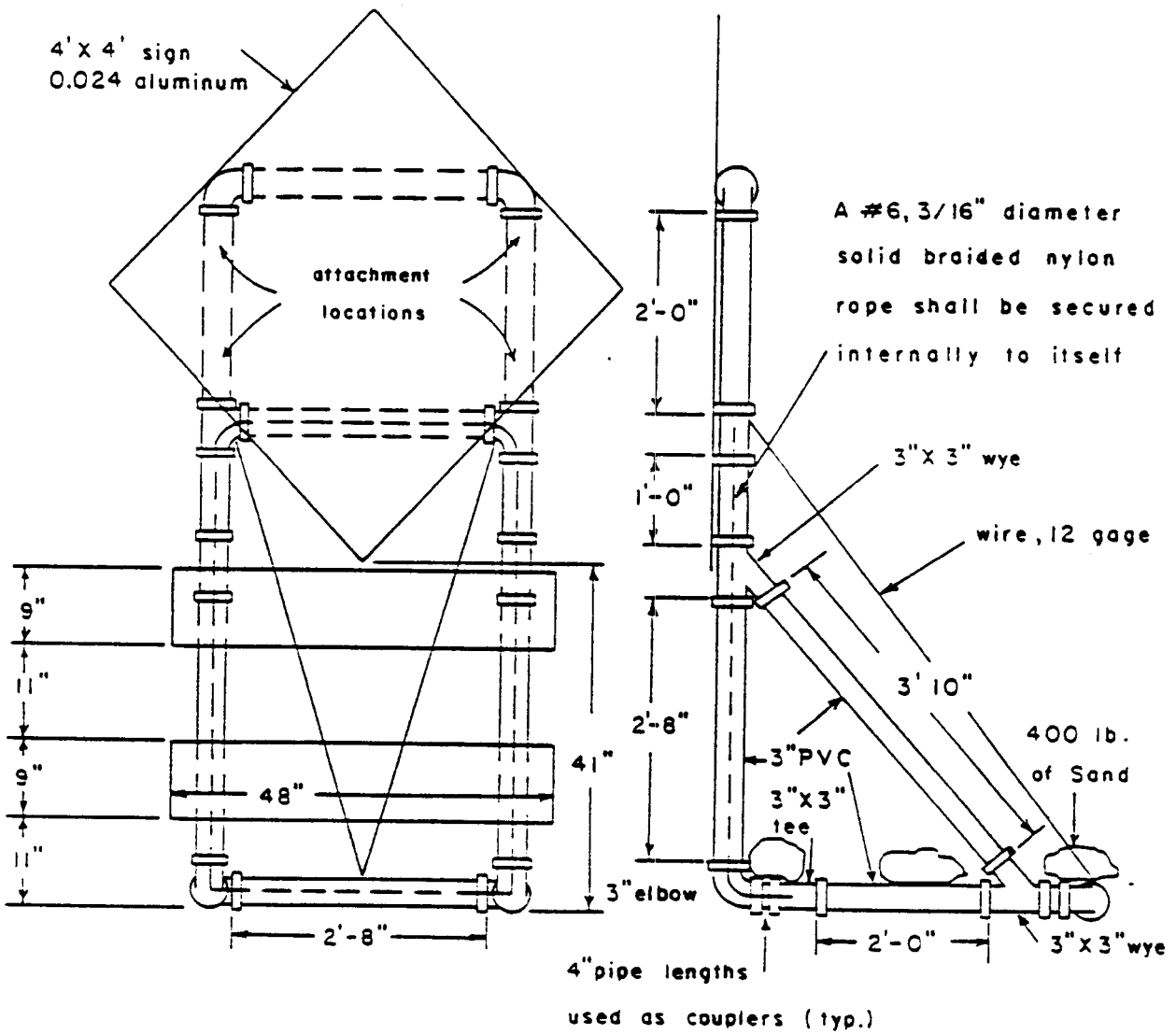

# FIGURE 9. VINYL SIGN ON BARRICADE WITH 21" OF CLEARANCE

**NOTE:**

All dimensions on full pipe length.

Socket depth of fittings is 1 1/2".

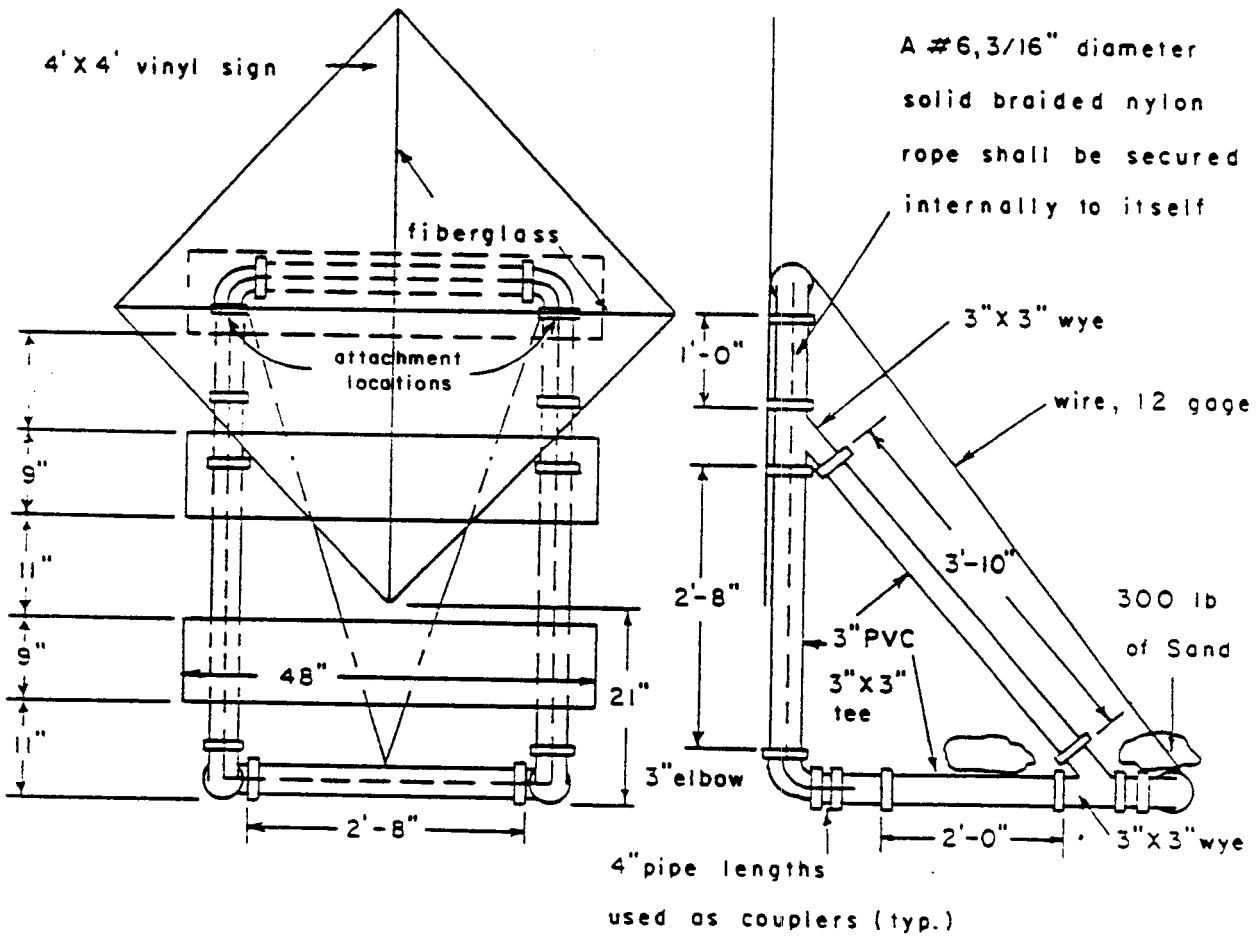

# FIGURE 10. VINYL SIGN ON BARRICADE WITH 38" OF CLEARANCE

NOTE:

All dimensions on full pipe length.

Socket depth of fittings is 1 1/2"

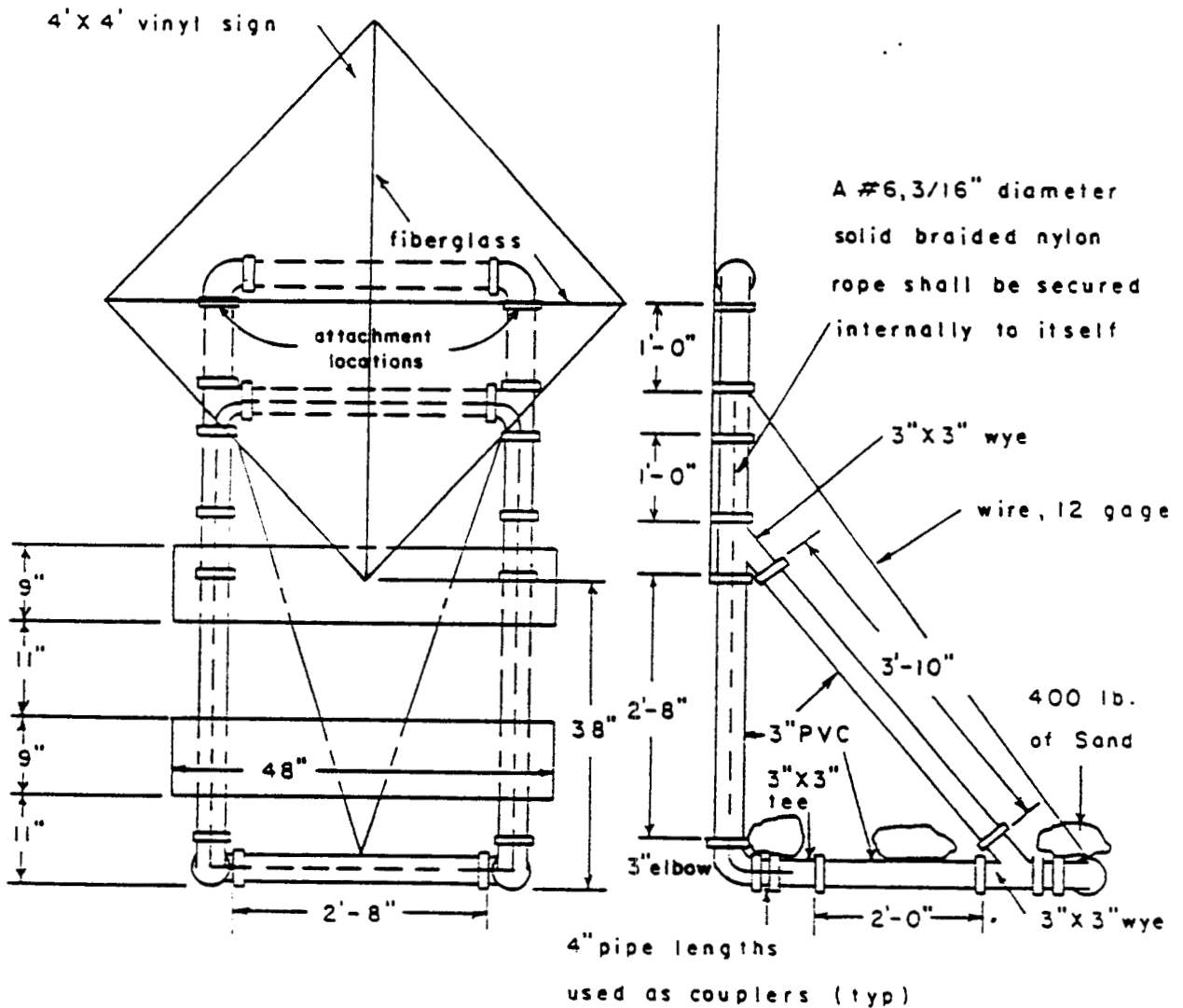



Appendix B. Preliminary Crash Tests



Figure 12. Preliminary Crash Test Vehicle Guidance System.



Figure 13. Preliminary Crash Test.

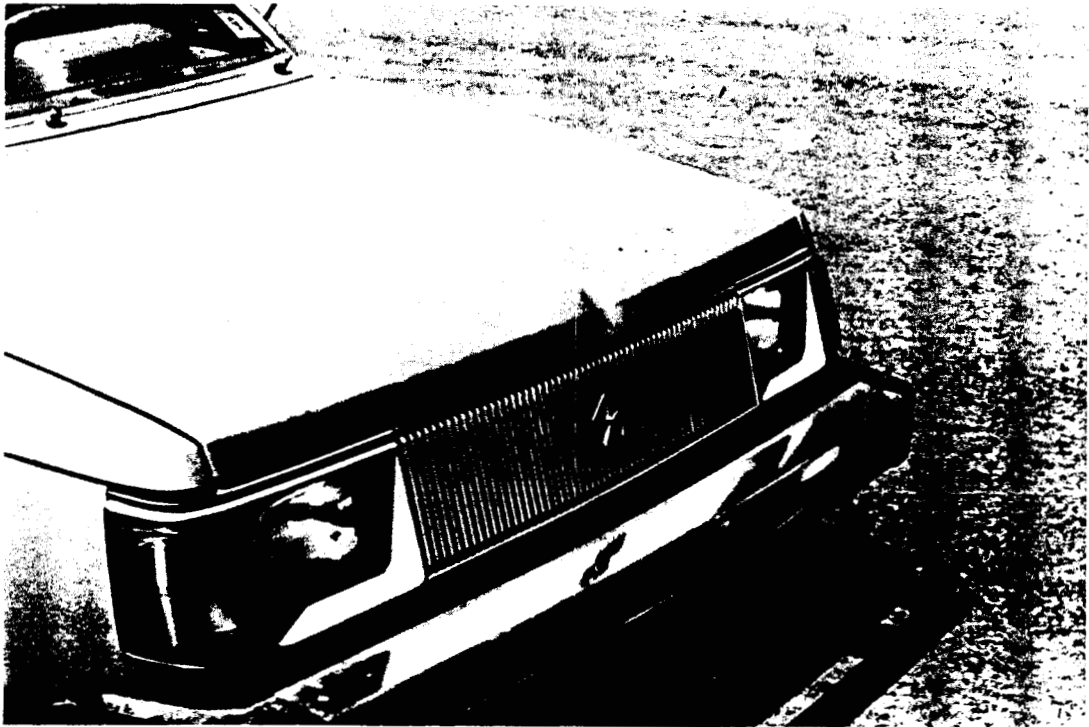

Figure 14. Typical Preliminary Crash Test Vehicle Damage.



Figure 15. Preliminary Crash Test Windshield Damage from 41" Clearance Aluminum Sign.