

Vehicle Impact Simulation for Curb and Barrier Design

Volume I – Impact Simulation Procedures

FINAL REPORT
October 1998

Submitted by

Gary R. Consolazio
Professor

&

Jae H. Chung
Research Assistant

Center for Advanced Infrastructure & Transportation (CAIT)
Civil & Environmental Engineering
Rutgers, The State University
Piscataway, NJ 08854-8014



NJDOT Research Project Manager
Mr. Robert Baker

In cooperation with

New Jersey
Department of Transportation
Division of Research and Technology
and
U.S. Department of Transportation
Federal Highway Administration

Disclaimer Statement

"The contents of this report reflect the views of the author(s) who is (are) responsible for the facts and the accuracy of the data presented herein. The contents do not necessarily reflect the official views or policies of the New Jersey Department of Transportation or the Federal Highway Administration. This report does not constitute a standard, specification, or regulation."

The contents of this report reflect the views of the authors, who are responsible for the facts and the accuracy of the information presented herein. This document is disseminated under the sponsorship of the Department of Transportation, University Transportation Centers Program, in the interest of information exchange. The U.S. Government assumes no liability for the contents or use thereof.

1. Report No.		2. Government Accession No.		3. Recipient's Catalog No.	
4. Title and Subtitle Vehicle Impact Simulation for Curbs and Barrier Design Volume 1 – Impact Simulation Procedures				5. Report Date October 1998	
				6. Performing Organization Code CAIT/Rutgers	
7. Author(s) Gary R. Consolazio and Jae H. Chung				8. Performing Organization Report No.	
9. Performing Organization Name and Address New Jersey Department of Transportation CN 600 Trenton, NJ 08625				10. Work Unit No.	
				11. Contract or Grant No.	
12. Sponsoring Agency Name and Address Federal Highway Administration U.S. Department of Transportation Washington. D.C.				13. Type of Report and Period Covered Final Report 01/13/1997 - 08/18/1998	
				14. Sponsoring Agency Code	
15. Supplementary Notes					
<p>16. Abstract</p> <p>The objectives of this study were to perform computer simulations of vehicle-curb and vehicle-berm impacts, to characterize the behavior of a wide range of vehicle types after such impacts, and to produce design and evaluation trajectory data for use by NJDOT engineers. The impact simulations performed involved a wide variety of vehicle types and several different curb and berm configurations that are typical of those in use in the state of New Jersey. Simulation results from this research, primarily in the form of vehicle bumper trajectory plots, were produced to supplement existing curb-impact vehicle trajectory databases. Vehicle trajectory data of this type is typically used to determine appropriate set-back distances for guide rails (railings) that are located near curbs. Such railings must be positioned so that vehicles impacting curbs do not overshoot the top of railings placed nearby.</p> <p>Due to the wide variety of curb and berm profiles used in New Jersey and due to the even wider variety of vehicle types traveling our roadways, a large number of impact simulations were performed for this project in an attempt to cover an adequate spectrum of possible impact scenarios. Six different vehicle types- including vehicles ranging from compact cars to minivans and sport utility vehicles- were simulated impacting several different curb and berm profiles. In addition, for each vehicle and curb combination, the impact simulations were performed for several different impact angles and impact speeds. To account for possible variations in vehicle suspension characteristics, a range of vehicle suspension values were used for each vehicle simulated. After performing the impact simulations using suspension values at both ends of the chosen range of values, an envelope of possible vehicle trajectories was generated from the simulations results.</p> <p>The research approaches employed in this project consisted of using numerical simulation techniques to perform vehicle impact analysis. These techniques were the HVOSM (highway vehicle object simulation model) method and the FEA (finite element analysis) method. The HVOSM system represents a vehicle as a relatively small number of discrete objects, each having lumped mass an inertial properties, and each being connected to other parts of the vehicle through links. Vehicle and tire properties for use in the HVOSM simulations were obtained from several different sources available in research literature. In the FEA method, a fundamentally different approach is used. Rather than representing the vehicle by a small number of "lumped" objects, the FEA approach is to model the vehicle as a large collection of very small pieces (or elements). Each element accounts for only a small portion of the vehicle and the properties of each element represent the properties (e.g. tire stiffness, steel stiffness, etc). of that small portion of the vehicle. These elements are then linked together into a large model, typically on the order of several thousands to tens of thousands of elements in size. Each of these methods, i.e. HVOSM and FEA, offer some advantages and disadvantages. These issues are discussed in detail in this report.</p>					
17. Key Words simulations, vehicle impact, vehicle trajectory, HVOSM			18. Distribution Statement		
19. Security Classif (of this report) Unclassified		20. Security Classif. (of this page) Unclassified		21. No of Pages 77	22. Price

PROJECT SUMMARY

The objectives of this study were to perform computer simulations of vehicle-curb and vehicle-berm impacts, to characterize the behavior of a wide range of vehicle types after such impacts, and to produce design and evaluation trajectory data for use by NJDOT engineers. The impact simulations performed involved a wide variety of vehicle types and several different curb and berm configurations (profiles) that are typical of those in use in the state of New Jersey. Simulation results from this research, primarily in the form of vehicle bumper trajectory plots, were produced to supplement existing curb-impact vehicle trajectory databases. Vehicle trajectory data of this type is typically used to determine appropriate set-back distances for guide rails (railings) that are located near curbs. Such railings must be positioned so that vehicles impacting curbs do not overshoot the top of railings placed nearby.

Due to the wide variety of curb and berm profiles used in New Jersey and due to the even wider variety of vehicle types traveling our roadways, a large number of impact simulations were performed for this project in an attempt to cover an adequate spectrum of possible impact scenarios. Six different vehicle types—including vehicles ranging from compact cars to minivans and sport utility vehicles—were simulated impacting several different curb and berm profiles. In addition, for each vehicle and curb combination, the impact simulations were performed for several different impact angles and impact speeds. To account for possible variations in vehicle suspension characteristics (e.g. suspension stiffness), a range of vehicle suspension values were used for each vehicle simulated. After performing the impact simulations using suspension values at both ends of the chosen range of values, an envelope of possible vehicle trajectories was generated from the simulation results.

The research approaches employed in this project consisted of using numerical simulation techniques to perform vehicle impact analysis. These techniques were the HVOSM (highway vehicle object simulation model) method and the FEA (finite element analysis) method. The HVOSM system represents a vehicle as a relatively small number of discrete objects, each having lumped mass and inertial properties, and each being connected to other parts of the vehicle through links. Vehicle and tire properties for use in the HVOSM simulations were obtained from several different sources available in research literature. In the FEA method, a fundamentally different approach is used. Rather than representing the vehicle by a small number of “lumped” objects, the FEA approach is to model (represent) the vehicle as a large collection of very small pieces (or elements). Each element accounts for only a very small portion of the vehicle and the properties of each element represent the properties (e.g. tire stiffness, steel stiffness, etc.) of that small portion of the vehicle. These elements are then linked together into a large model, typically on the order of several thousand to tens of thousands of elements in size. Each of these methods, i.e. HVOSM and FEA, offer some advantages and some disadvantages. These issues are discussed in detail in this report.

ACKNOWLEDGEMENTS

The authors wish to express their appreciation to the New Jersey Department of Transportation (NJDOT) for funding the research described herein. The authors also wish to thank the National Crash Analysis Center (NCAC) and the Lawrence Livermore National Laboratories (LLNL) for providing some of the finite element vehicle models that were evaluated during this project. Finally, the authors wish to thank the LLNL Methods Development Group for furnishing the DYNA3D simulation code through their Collaborators Program.

TABLE OF CONTENTS

VOLUME I – IMPACT SIMULATION PROCEDURES

Project Summary	i
Acknowledgements	ii
1. Objectives	1
2. Introduction	1
3. Available Impact Simulation Techniques	4
4. Modeling Vehicle Dynamics and Impacts Using HVOSM	8
4.1 Tire Model	10
4.2 Suspension Model	13
4.3 Curb and Berm Models	16
5. Selection of Vehicles for HVOSM Simulation	18
6. Acquisition of Vehicle Data for HVOSM Simulation	19
7. Curb And Berm Impact Simulations Using HVOSM	27
7.1 Coordinate Systems Used in HVOSM	31
7.2 Vehicle Bumper Dimension and Location data	32
7.3 Computing Bumper Trajectory Data from HVOSM Trajectory Data	33
8. Accuracy and Limitations of HVOSM Impact Simulation	35
9. Curb and Berm Impact Modeling Using FEA	39
9.1 Motivation for Using FEA for Curb and Berm Impacts	39
9.2 FEA Impact Simulation Codes	40
9.3 Vehicle Modeling for FEA	42
10. Preliminary Curb Impact Simulation Results Using FEA	44
11. Conclusion	49
References	52
Appendix A –Vehicle Parameter Data Blocks for HVOSM	54
Appendix B –Curb and Berm Data Blocks for HVOSM	67

VOLUME II – TRAJECTORY PLOTS FOR FORD ESCORT

VOLUME III – TRAJECTORY PLOTS FOR HONDA CIVIC

VOLUME IV – TRAJECTORY PLOTS FOR CHEVY CAVALIER

VOLUME V – TRAJECTORY PLOTS FOR CHEVY PICKUP

VOLUME VI – TRAJECTORY PLOTS FOR PLYMOUTH VOYAGER

VOLUME VII – TRAJECTORY PLOTS FOR JEEP WRANGLER

1. OBJECTIVES

The objectives of this study were to perform computer simulations of vehicle-curb impacts, to characterize the behavior of a wide range of vehicle types after such impacts, and to produce design and evaluation trajectory data for use by NJDOT engineers. The impact simulations performed involved a wide variety of vehicle types, impact angles, impact speeds, and curb and berm configurations (profiles) typical of those used in New Jersey. Simulation results from this research, primarily in the form of vehicle bumper trajectory plots were produced to supplement existing impact trajectory databases. Vehicle trajectory data of this type is typically used to determine appropriate set-back distances for guide rails (railings) that are located near curbs. Such railings must be positioned so that vehicles impacting curbs do not overshoot the top of railings placed nearby.

2. INTRODUCTION

When a vehicle loses control and veers off of a roadway, safety structures such as barriers and railings must ensure that the vehicle is redirected back onto the roadway in as safe a manner as possible. In addition, the presence of some types of roadway appurtenances, for example curbs, can complicate the behavior of a vehicle that has lost control. If railings are present, they must be placed at appropriate locations relative to curbs in order to be effective in redirecting stray vehicles. If the railings are improperly positioned, vehicles could potentially follow a post impact trajectory (by “post impact” we mean “occurring after the impact”) in which the bumper of the vehicle does not come in contact with the railing (see figure 1). In such a case, the ability of the railing system to redirect the vehicle back onto the roadway will be substantially compromised.

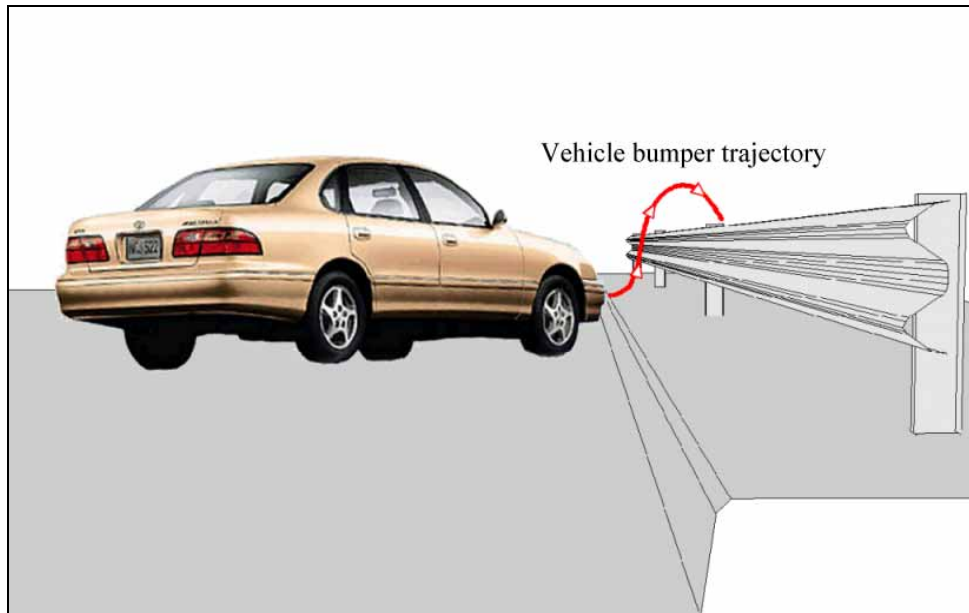

Figure 1. Guide Rail Improperly Positioned Relative to a Curb

The most reliable method for evaluating the adequacy of roadside safety hardware is to perform full scale crash tests. Unfortunately, these tests are complex and expensive to perform. In addition, it is never adequate to perform a single full scale crash test because the roadside safety feature in question—e.g. a guide rail—must be able to perform adequately under numerous impact scenarios and for different vehicle types. For this reason, full scale crash testing of roadside safety hardware requires crashing testing for several different impact conditions and with more than one vehicle type. Test matrices of impact conditions and vehicle characteristics for full scale crash tests are specified in NCHRP 350 (NCHRP-350 1993). Also, for some types of impact conditions, it can be very difficult, impossible, or cost-prohibitive to perform full scale crash tests. Examples include side impact conditions, other non-tracking types of impacts, and impacts with roadside safety features located at the edges of slopes.

For these reasons, numerical simulation techniques have been developed to study vehicle impact situations and to study the effectiveness of roadside safety hardware in various impact

situations. Numeric simulation (referred to hereafter simply as “simulation”) is the process of using numerical methods of dynamic, structural, and contact analysis to predict the behavior of a vehicle during and following an impact. Several different vehicle impact simulation techniques are presently available ranging from simpler single-purpose type simulations to very general, sophisticated modeling and analysis techniques that can be applied to a wide variety of impact conditions. A survey of the current state of the art and a description of several of the simulation codes presently in use in research and industry is given in the next section of this report.

Simulation offers many advantages over full scale crash testing but also has some fundamental limitations. One of the key advantages of using simulation is the reduced cost per “test” or, in the case of simulation, the reduced cost per “impact simulation”. Once the basic components of the simulation technique have been developed—i.e. the analysis code and vehicle models and roadside hardware models—numerous simulations can be performed for relatively low cost, provided that adequate computing hardware is available. For example, different impact angles, impact speeds, and curb profiles could be simulated without the need for crashing numerous vehicles. In addition, impact conditions that are difficult to test experimentally (i.e. using full scale crash tests) can be more easily studied using simulation. For example, non-tracking impacts and impacts with railings on slopes can be simulated more easily than they can be experimentally tested. In fact, NCHRP 350—Appendix D addresses some of the advances that had occurred in the area of analytical impact simulation at the time that the 350 document was being prepared. And just as NCHRP 350 was an update to its predecessor NCHRP 230 (NCHRP-230 1980), the update to NCHRP 350 will likely address the use of analytical impact simulation in greater depth than does NCHRP 350.

Despite the substantial advancements that have been made in impact simulation techniques during the past few decades and despite the drastic reductions in the cost of computer hardware on which to perform these analyses, the fact remains that simulations are still predictions of what will happen, not actual records of what *did happen* during a test. For this reason, simulation techniques still need at least limited full scale crash testing for validation purposes. At present, an area of great interest and research effort is the topic of establishing the degree to which simulation results (e.g. vehicle trajectories, vehicle accelerations, etc.) must match full scale crash test results in order to have confidence in the simulation techniques under consideration.

It appears that the most likely outcome will be the increased use of simulation for preliminary design, performing parametric studies, prototyping and initial design of hardware, and studying complex impact conditions which are difficult to test in full scale. However, along with these tools, there will continue to be a need for full scale crash testing to validate the numeric simulations for less complex impact conditions (e.g. those specified in NCHRP 350).

3. AVAILABLE IMPACT SIMULATION TECHNIQUES

Many numerical simulation techniques have been developed during the past few decades for purposes of analyzing vehicle impact conditions. The techniques (packaged in the form of computer programs) that have gained at least somewhat wide acceptance are briefly described below. Most of these programs (or packages of programs) tend to have been developed with a particular application in mind and therefore will have particular strengths and weaknesses depending on the application. In choosing to use any of these programs, careful consideration should be given to matching an impact problem (e.g. the computation of vehicle trajectories after curb impacts) with simulation packages that excel in that particular type of impact simulation.

For example, it would not be wise to use a simulation package that excels at predicting barrier deformations in order to perform simulation involving the prediction of vehicle trajectories for vehicles striking rigid curbs.

Below are brief descriptions of some of the simulation packages that have found the most widespread use during the past few decades.

- Barrier VII : Barrier VII is a simulation code used for studying flexible barrier impacts. It utilizes two-dimensional structural finite elements to model physical rail components such as railings, posts, cables, hinges, etc. and utilizes two-dimensional, three degree-of-freedom planar vehicle models. Nonlinearities, both material and geometric, are included in the model. This simulation program is best suited for computing loads on barrier components and barrier deflections and has been validated for a wide range of barrier and vehicle types. However, due to the two-dimensional nature of the modeling, this code cannot be used to study vehicle stability, predict vehicle vaulting or under-riding of barriers, or predict vertical trajectories after curb or berm impacts.
- GUARD : The GUARD program utilizes three-dimensional finite elements to model barrier components and a six degree-of-freedom vehicle model. The added complexity in the barrier and vehicle modeling used by this simulation package should allow it to predict accurate data where other, less complex codes are not as accurate. Instead however, the program is unable to accurately handle the analysis of structural systems in which the stiffness matrices are ill-conditioned. An example of such ill conditioned systems is the analysis of impacts with W-rail barriers in which the rail has high axial stiffness but very low torsional stiffness. In addition, the tire and suspension models implemented in GUARD are very limited and preclude

the use of this program in handling curb impact analysis. Finally, the code has not been adequately validated.

- NARD : The NARD (numerical analysis for roadway design) program is based in part on the GUARD program but with several improvements. It is intended to be used for analyses involving the study of both vehicle stability and barrier behavior during impact. The NARD tire and suspensions models are more sophisticated than those used in GUARD and therefore should be more applicable to curb impact analysis. However, since NARD is based in part on GUARD, it exhibits the same limitations as GUARD in the analysis of systems with ill-conditioned stiffness matrices. Also like GUARD, NARD has not been adequately validated.
- SMAC : The SMAC (simulation model for automobile collisions) is a numerical analysis tool primarily intended for use in reconstruction of traffic accidents involving two cars. It is based on two-dimensional modeling in which each vehicle is modeled as a planar, crushable object. It has been used to study vehicle impacts with crash cushions and guide rail treatments but is limited by the simplified vehicle modeling implemented. It is also not appropriate for curb impact problems since the simulations are two-dimensional and therefore are incapable of predicting vehicle stability information or vehicle trajectory data.
- HVOSM : The HVOSM (highway vehicle object simulation model) (Segal 1976) is a vehicle handling computer simulation model that implements moderately sophisticated vehicle, suspension, and tire models. Vehicles are modeled using a relatively small number of discrete objects that are interconnected using springs and dampers that simulate the characteristics of the vehicle suspension. Tires are modeled using a thin disk approximation in which radial springs represent the stiffness of the tires during impact and interaction with roadside features such as curbs and sloped berms. HVOSM has been well tested and validated against a large

number of actual full scale crash tests and has demonstrated an ability to predict vehicle behavior in cases where vehicle stability and vehicle trajectories are of interest. It is appropriate for simulating curb impacts of the type studied in this research project. The limitations of the HVOSM method that are pertinent to this study are the limitations of the *thin disk tire* model, the inability to account for wheel or suspension *damage* during an impact, and the relatively *simplistic crush modeling* of vehicle body damage in cases of vehicle-railing interaction. Despite the limitations, the HVOSM code is capable of predicting useful trajectory data for curb and berm impact situations and was used extensively in this project.

- FEA : The FEA (finite element analysis) method is a state-of-the-art method for vehicle impact analysis. FEA is a *very* general solution method that has been used in fields ranging from solid mechanics (structural analysis of solid systems such as buildings, bridge, vehicles, barriers, etc.) to fluid mechanics, electromagnetics, and thermal analysis. In the context of vehicle impact analysis, it can be used to accurately model the behavior of vehicles in a wide range of impact situations. In FEA, the large objects involved in the crash simulation—e.g. vehicle and guide rails—are modeled using a large quantity of “finite size” elements. By linking these small elements together and modeling their dynamic and contact behavior during an impact, vehicle crash situations can be properly analyzed. (Further details of FEA modeling for vehicle impact are given later in this report). While there are numerous FEA simulation codes available, the LS-DYNA3D (LSTC 1998) code has gained widespread acceptance by the roadside safety simulation community primarily due to its sophisticated handling of contact interactions during impacts. The primary advantage that FEA has over the other methods listed above is its great flexibility in being able to model widely varying impact situations ranging from vehicle-barrier interaction (e.g. prediction of snagging and

vaulting), vehicle dynamics (e.g. stability and trajectories), and assorted impact conditions (e.g. tracking, side, and general non-tracking). The primary limitation of the FEA method is that it takes a large amount of effort to *develop* and *validate* sophisticated vehicle models that have adequate accuracy for use in roadside hardware design. It is also a computationally demanding method requiring substantial computer resources to perform many types of simulation. However, due to its many advantages and due to the dropping cost of computer equipment, the FEA method will almost certainly be the primary analysis tool for roadside safety simulation in the 21st century.

While there are a considerable number of simulation tools available for vehicle impact simulation, as is indicated by the abbreviated list above, the two methods that are most appropriate for this research project are HVOSM and FEA. Since one of the primary goals in this research was to develop trajectory plots for a wide variety of impact situations, the ability to compute vertical vehicle trajectories was of primary importance. The HVOSM and FEA methods offer the needed analysis capabilities and were the methods chosen for use in this study.

4. MODELING VEHICLE DYNAMICS AND IMPACTS USING HVOSM

HVOSM is an acronym for “highway vehicle object simulation model” and is a simulation code (computer program) for studying vehicle redirection, vehicle handling, and vehicle motion after impacts with rigid objects such as curbs and concrete barriers. HVOSM was originally developed by the Calspan Corporation in 1966 to facilitate computer simulation of the dynamic responses of automobiles during accidents. Since that original version, several revisions, modifications, and enhancements (e.g. NCHRP-150 1974, Heydinger 1980, Holloway,

Sicking and Rosson 1994) have been made to the original simulation code. However, many of the basic modeling methods employed in the original version remain intact.

The version of HVOSM used in the present research study was version HVOSM-RD2 (i.e. the “roadside design” version) which is capable of simulating impacts with roadside terrain and obstacles such as curbs, earth berms, and cut/fill slopes. The code is capable of simulating the rigid body dynamics of an automobile undergoing arbitrary maneuvers (e.g. rotations and translations along a vehicle trajectory path through space) in a roadside environment setting. The overall capabilities of HVOSM-RD2 are as follows:

1. Motions of vehicles with either independent suspension or solid axle suspension or combinations.
2. Impacts between the vehicle body and roadside structures (to a limited extent).
3. The effects of variable terrain on vehicle response.
4. The effects of contact between tires and curbs on vehicle response.

In the HVOSM model, vehicles are modeled (i.e. represented numerically in the simulation) using a series of discrete objects—such as tires, axles, the vehicle body, etc.—that are connected together using springs and dampers. The springs and dampers are used to mathematically mimic the response of vehicle components such as the suspension, tire and wheel assembly stiffness and damping, anti-pitch behavior, and other related systems and components.

Vehicles modeled using HVOSM are limited to four wheels with either rigid axles or independent suspension. The total number of degrees of freedom (DOF) in the analytical representation of the vehicle is eleven. A DOF (degree of freedom) is an independent variable that is used in the solution of the vehicle motion during an impact. For example, the X, Y, and Z translations and the ψ (yaw), θ (pitch), and ϕ (roll) rotations angles are the six DOFs that represent position and orientation of the vehicle body (called the “sprung mass” in HVOSM terminology) in space.

There are additional DOFs that correspond to the “unsprung masses” (i.e. wheels and axles) and the steering. Thus, there are a total of eleven DOFs in the HVOSM vehicle model. A typical HVOSM vehicle model is shown in figure 2.

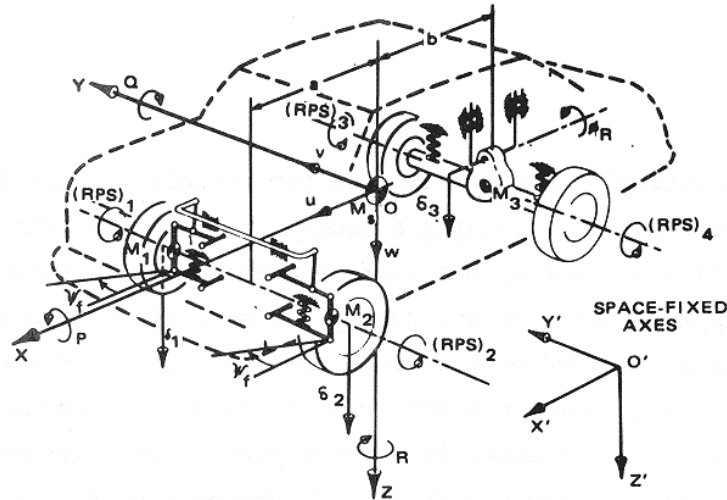

Figure 2. HVOSM Model of a Vehicle Having Independent Front Suspension and a Solid Rear Axle

Note that while there are only eleven DOFs in the HVOSM vehicle models, there is a much larger number of vehicle parameters that must be specified to mathematically describe how these eleven DOFs interact with each other during an impact. For example, between the “sprung mass” and the axles, there are suspension springs, bump stoppers, anti-pitch devices, and other factors that all affect how the body (sprung mass) and the rest of the vehicle interact.

4.1 TIRE MODEL

The tire model used in HVOSM for curb impacts consists of a *thin disc* with nonlinear radial springs (see figure 3) spaced uniformly around the wheel at 4 degree intervals. The load deflection characteristics of a tire are represented by using a bilinear load-deflection curve (see figure 4) corresponding to “equivalent” flat terrain loading.

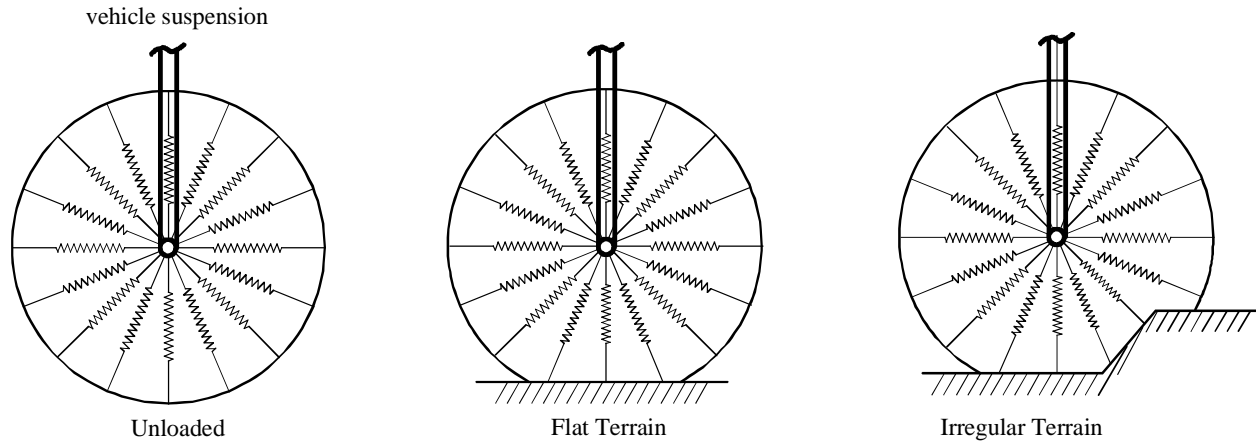

Figure 3. Thin-Disk Radial Spring Tire Model Used in HVOSM

The HVOSM code automatically computes the nonlinear stiffness characteristics of the radial springs so that the “equivalent flat terrain” deflection of the tire matches that described by the load deflection curve (figure 4) specified by the program user. Thus, to describe the tire stiffness characteristics, the user must specify the parameters K_T , λ , and σ_T . These three parameters form a bilinear curve that relates the applied load (in pounds) on the tire to the deflection of the tire (in inches). Tire deflection is measured as $R_w - h_i$, where R_w is the undeflected tire radius and h_i is the rolling tire radius at a particular level of applied tire load.

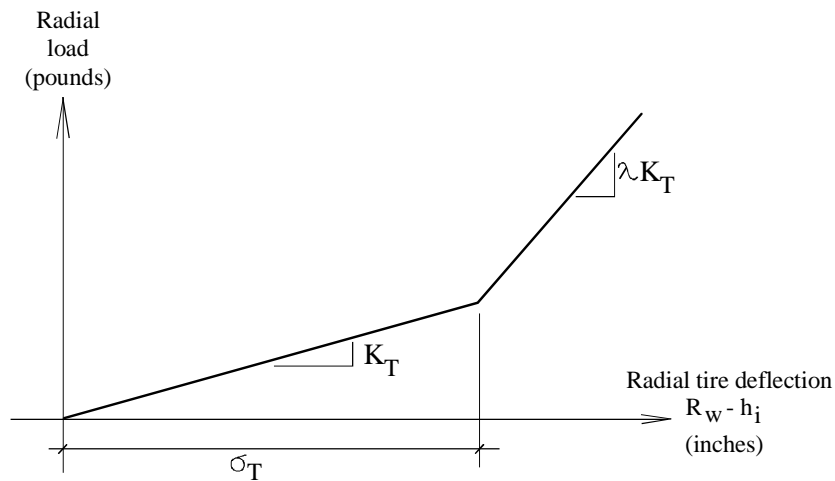

Figure 4. Load Deflection Curve Used to Describe Tire Stiffness in HVOSM

In addition to radial tire forces, there are of course also tire *side forces* that must be accounted for in simulating vehicle motion and tire interaction with the roadway and terrain. Tire side forces in HVOSM account for camber angle and slip angle. The camber angle, ϕ , of a tire is the angle between the vertical plane of the tire and the normal to (i.e. direction perpendicular to) the surface that the tire is in contact with (e.g. flat roadway or sloped curb faces). Camber angle is illustrated in figure 5.

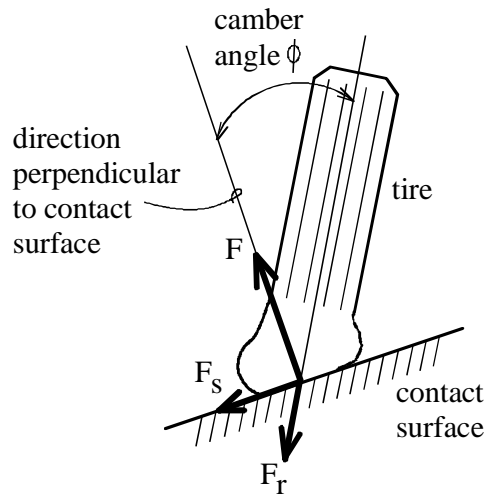

Figure 5. Forces on a Tire Due to Camber Angle ϕ , Slip Angle α , and Radial Deformation

In this figure, the force F_r is the radial tire force generated by deformation of the radial tire springs described above. That is, F_r is the resultant radial tire force that is described by the bilinear curve in figure 4. The force F_s in figure 5 is the resultant side force on the tire (parallel to the tire-terrain contact patch) due to *both* camber angle ϕ and slip angle α of the tire. The force F in the figure is the resultant force that is normal to (perpendicular to) the tire-terrain contact patch. It is this force F that, in conjunction with additional friction parameters, determines how the vehicle responds and behaves during cornering and during interaction with sloped surfaces such as curbs and berms.

The tire slip angle, α , cited above, relates to the deformed shape of the tire when the tire is rolling and a side force (e.g. due to cornering of the vehicle) is simultaneously acting on the tire. During cornering, the deformed shape of the tire-terrain contact patch takes on a form such as that shown in figure 6 (which also defines the slip angle).

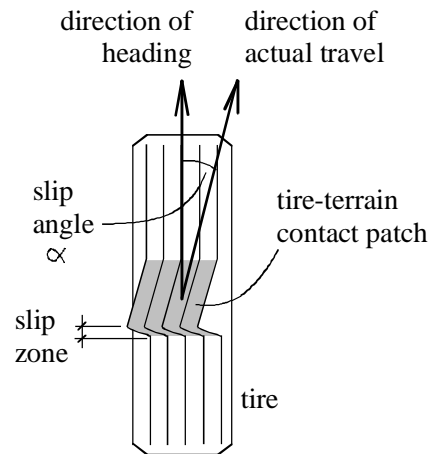

Figure 6. Tire Slip Angle α While Tire Rolls and is Simultaneously Subject to Side (Lateral) Force [after Gillespie 1992]

The maximum side force that can be developed by the tire can be related to the normal force acting on the tire and the slip angle α and then plotted in the form of a “carpet plot”. Such plots are discussed in more detail in Gillespie (1992) and Segal (1976).

4.2 SUSPENSION MODEL

The suspension model incorporated into HVOSM includes stiffness characteristics, damping characteristics, anti-pitch stiffness, and anti-roll stiffness. Suspension stiffness and energy dissipation are represented using curves of the form shown in figure 7. In this format, the stiffness (i.e. load-deflection relationship) of the suspension is represented as a linear curve at low load (force) level and as a cubic function at higher load levels.

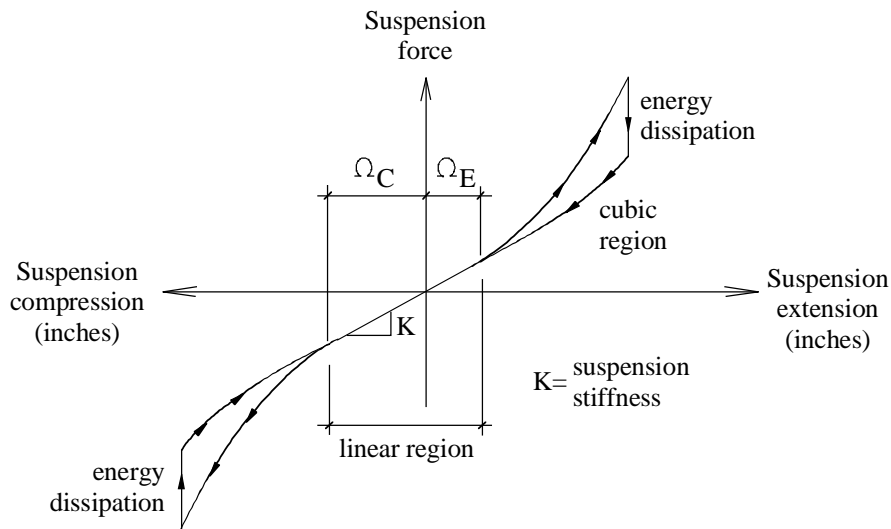

Figure 7. Suspension Force Characteristics and Energy Dissipation

A spring stiffness factor K is used to describe the stiffness of the suspension in the linear region and cubic function coefficients are used to describe the nonlinear portions of the curve. Two transition values— Ω_C on the compression side and Ω_E on the extensional side—are used designate the deflection at which the suspension stiffness begins to increase cubically in resistance. These transition values correspond to the suspension deflections (in inches) at which rubber suspension bumpers are engaged (see figure 8). When the bumpers engage, the total stiffness of the suspension (i.e. the stiffness of coil springs, leaf springs, *and* the rubber bumper) typically increases significantly and rapidly. It was found in this research, that the choice of Ω_C was particularly important in determining the vehicle trajectory after impacts with curbs. This is due to the fact that the compression bumpers are usually engaged during such an impact event. Exceptions to this general rule are low speed impacts and impacts with very shallow curbs.

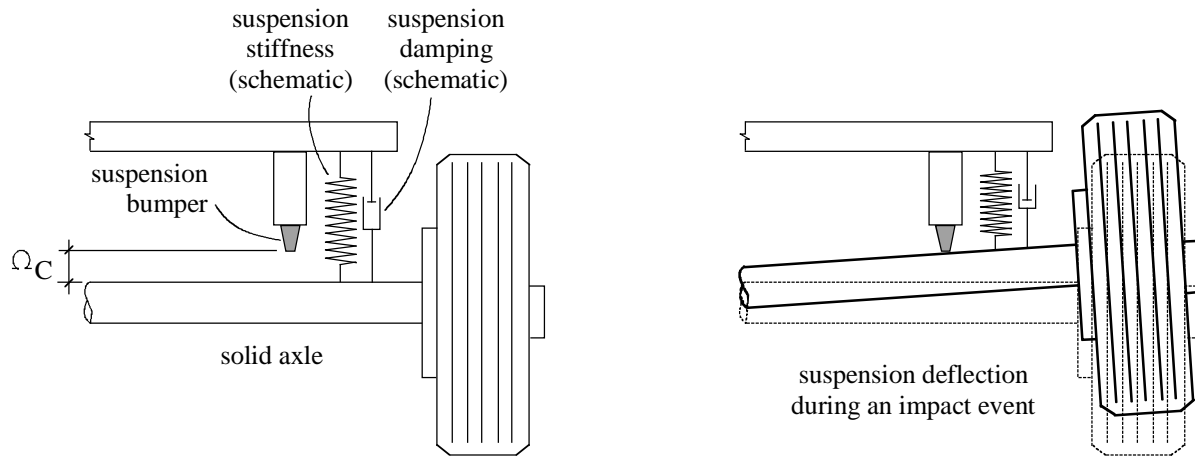

Figure 8. Suspension Bumper (on Compression Side) Being Engaged During an Impact Event

Suspension stiffness parameters— K , Ω_C , Ω_E and the cubic curve coefficients on the compression and extension sides—are specified for the front axle and again for the rear axle. Further discussion of the importance of these values is given later in this report.

Damping of suspension movements, as would be caused by shock-absorbers in the vehicle's suspension system, is modeled in HVOSM using damping curves of the form shown in figure 9. In this manner, both Coulomb damping and viscous damping in the suspension can be taken into account. Coulomb damping is defined as a damping condition in which a *constant* damping force opposes the oscillatory (or vibratory) motion of the suspension and tries to damp out the motion. In contrast, viscous damping is defined as a damping condition in which the damping force is still opposite to the vibratory motion but is now also *proportional* in magnitude to the velocity of the vibration—i.e. a faster velocity suspension motion will cause the development of a larger damping force to counter that motion.

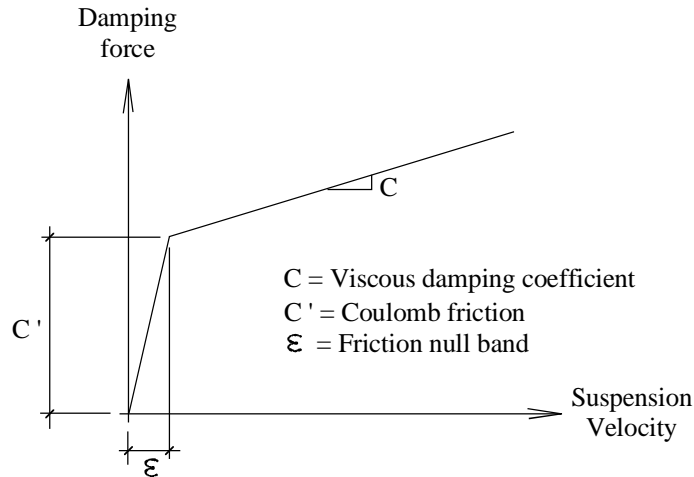

Figure 9. Suspension Damping Characteristics

In addition to suspension stiffness and damping characteristics, additional characteristics such as anti-pitch and anti-roll characteristics are also included. For example, the effects of torsion bars and the torsional stiffness of leaf springs can introduce additional roll stiffness (stiffness that would prevent overturning of a vehicle onto its side) into the suspension that cannot be determined solely from the suspension stiffness and spring moment-arm parameters. Thus, these additional characteristics must also be specified for the vehicle when performing HVOSM impact simulations.

4.3 CURB AND BERM MODELS

All roadside terrain in HVOSM simulations is assumed to be rigid in nature. This approximation is clearly applicable to the case of concrete curbs but may be less applicable to soil berms if significant plowing of the tires into the soil is expected. It is assumed in HVOSM, that the roadside terrain can be fully represented by describing a cross section of the terrain (using specified coordinates and slopes) as shown in figure 10. This cross section is then assumed to be extruded along the direction of the roadway to infinity (see figure 11). For many situations

involving impacts with curbs and berms—in which no significant changes in the shape of the terrain occur as one moves in the direction of the roadway—the HVOSM extrusion assumption does not cause any significant problem. For simulating impacts in which significant variation in the roadside terrain occurs as one moves in the direction of the roadway, other researchers (Ross et al. 1994) have developed modified versions of HVOSM that overcome the limitation of the extrusion assumption.

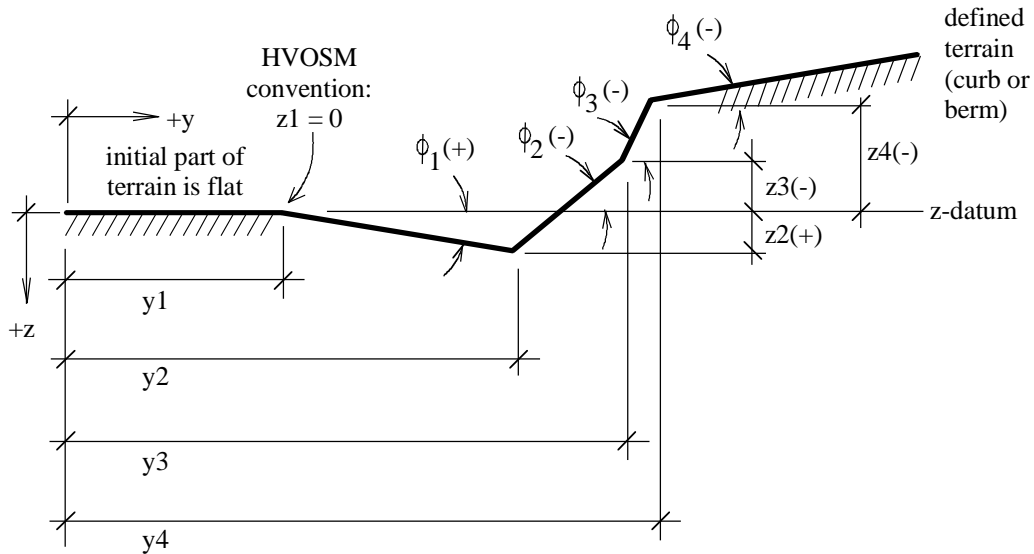

Figure 10. Definition of Cross-Section of Terrain (Curb or Berm)

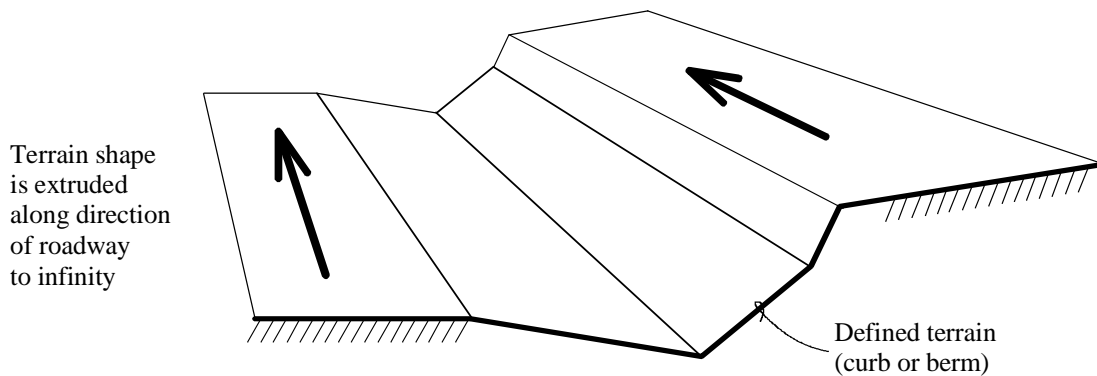

Figure 11. Extrusion of Defined Terrain Cross-Section Along Direction of Roadway

Initially, all wheels of the vehicle are assumed to be on a flat ground surface having a friction coefficient of μ . The vehicle is given an initial position, a specified angle of approach, and initial velocity. When the wheels of the vehicle come in contact with curb (or berm) faces, the friction between the tires and the sloped surfaces is given by the product $\mu \cdot \mu_C$, where μ_C is the “curb friction multiplier”, i.e. a frictional scaling factor for curb impact. Both μ and μ_C are therefore required in setting up the HVOSM simulations. The specific terrain geometries for the curb and berm profiles simulated in this research project are given later in this report.

5. SELECTION OF VEHICLES FOR HVOSM SIMULATION

The fleet of passenger vehicles travelling today’s roadways is very diverse in nature and includes vehicles ranging from sub-compact cars to sport utility vehicles. In order to cover a reasonable range vehicles in the HVOSM simulations performed during this study, six different vehicles were chosen. They are:

1. Ford Escort (2 door small car, 1989)
2. Honda Civic (4 door small car, 1989)
3. Chevrolet Cavalier (4 door mid-size car, 1980’s)
4. Plymouth Voyager (van, 1980’s)
5. Chevrolet Pick-up (1980’s)
6. Jeep Wrangler (sport-utility vehicle, 1980’s)

The vehicles included in this list were chosen i) because they represent a reasonable sampling of the types of vehicles in use today, and ii) because vehicle data, in roughly the format needed for HVOSM simulation, were available in the literature. Actually, only limited vehicle data were available in actual HVOSM format and therefore much of the vehicle parameters were taken from other sources (described below) and then converted into HVOSM-compatible parameters.

6. ACQUISITION OF VEHICLE DATA FOR HVOSM SIMULATION

An extensive literature search was performed as part of this project to obtain the vehicle and tire parameters needed for the HVOSM impact simulations that were performed. The primary sources from which data were taken were Allen et al. (1992), Council et al. (1988), Ross and Sicking (1986), Heydinger (1980), Segal and Ranney (1978), and Segal (1976). Data for a wide range of vehicles were available in Allen et al. (1992) and much of the data needed for the HVOSM simulations performed in this project were taken from that source. However, many of the vehicle parameters provided in Allen et al. (1992) were in “forms” different from that needed in HVOSM. By “forms” we do not mean simply that the values were specified in a different input file format. Rather, we mean that the values given were related to but different from the corresponding HVOSM parameters. Thus, a large number of parameter conversion had to be made in order to use data from Allen et al. in the HVOSM simulations presented herein.

Some of these data conversions were as simple as converting units of inches to feet. Others involved examining the derivations and definitions of terms reported in Allen et al. and then deriving conversion equations to bring the data into an appropriate form for use in HVOSM. In addition, there were differences in the sign conventions (positive vs. negative values of vehicle parameters) between HVOSM and Allen et al. and derivations of terms had to be made in order to determine the correct method of translating the sign conventions of Allen et al. into HVOSM sign conventions. An example of this type of conversion issue was the translation of auxiliary roll stiffness parameters from Allen et al. into equivalent HVOSM auxiliary roll stiffness parameters. The complete set of HVOSM vehicle and tire parameters that were used in this project are given in Tables 1(a) through 1(f). Data conversion that were made from Allen et al. to HVOSM conventions are also indicated in the tables.

Table 1(a). Summary of HVOSM Parameters and Data Conversions

<p>DATA CARD 100</p> <p>1. Simulation title card</p>
<p>DATA CARD 101</p> <p>1. initial simulation time..... 0.0 sec. 2. final simulation time 5.0 sec.(varies: 5 to 8 sec.) 3. normal vehicle integration time step 0.005 sec. 4. output print time interval 0.001 sec. 5. maximum value of pitch angle 70 deg. 6. resultant linear velocity 0.0 in/sec. 7. resultant angular velocity 0.0 rad/sec.</p> <p><i>NOTE : 6 and 7 are for simulation termination. If both are less than the input values, the run is terminated.</i></p>
<p>DATA CARD 102</p> <p>1. ISUS, suspension option indicator: 0 : independent front, solid rear axle 1 : independent front & rear axles 2 : solid front & rear axles</p> <p>2. INDCRB, curb impact indicator..... 1 3. NCRBSL, number of curb slopes 6 4. DELTC, integration time step for impacts 0.001 sec.</p>
<p>DATA CARD 103</p> <p>1. numerical integration mode indicator 1 , Runge-Kutta method</p>
<p>DATA CARD 104</p> <p>1. angular accelerations blank 2. inclination camber angle of the wheels with respect to the ground 1 3. longitudinal and lateral velocities of the tire contact point with respect to the vehicle 1 4. elevation of ground contact point of tires 1 5. total suspension forces and suspension anti-pitch forces blank 6. suspension damping forces and change in spring forces from equilibrium..... blank 7. components of tire forces along the inertial axes blank</p> <p><i>NOTE : The array above is used to control output printed from a run. If an array element is non-zero, the group of output data corresponding to that element is printed.</i></p>
<p>DATA CARD 200</p> <p>1. vehicle title.</p>

Note: In these tables, [STI] indicates that the parameter names given and data values used were obtained from Allen et al. (report by Systems Technology Incorporated, 1992) and then converted into the correct forms for use in HVOSM.

Table 1(b). Summary of HVOSM Parameters and Data Conversions

DATA CARD 201	
1. XMS, sprung mass	SMASS/12 [STI]
2. XMUF, total front unsprung mass	UMASSF/12 [STI]
3. XMUR, total rear unsprung mass	UMASSR/12 [STI]
4. XIX, mass moment of inertia of the sprung mass about the vehicle X-axis	IXS*12 [STI]
5. XIY, mass moment of inertia of the sprung mass about the vehicle Y-axis	IYS*12 [STI]
6. XIZ, mass moment of inertia of the sprung mass about the vehicle Z-axis	IZZ*12 [STI]
7. XIXZ, mass moment of inertia of the sprung mass in the vehicle X-Z plane	IXZ*12 [STI]
8. XIR, mass moment of inertia of the solid axle rear unsprung mass (required only if ISUS = 0 or 2)	IXUR*12 [STI]
9. XIF, mass moment of inertia of the solid axle front unsprung mass (required only if ISUS = 2)	IXUF*12 [STI]
DATA CARD 202	
1. A, horizontal distance from sprung mass C.G. to centerline of front wheels	LENA*12 [STI]
2. B, horizontal distance from sprung mass C.G. to centerline of rear wheels	LENB*12 [STI]
3. TF, front wheel track	TRWF*12 [STI]
4. TR, rear wheel track	TRWB*12 [STI]
5. RHO, vertical distance between rear axle C.G and rear axle roll center	(HRAR-RR)*12 [STI]
6. TS, distance between rear mounts for solid rear axle	(TWRB-2*TWIDTH)*12 [STI]
7. RHOF, vertical distance between front axle C.G and front axle roll center	(HRAF-RR)*12 [STI]
8. TSF, distance between front mounts for solid front axle	(TWRF-2*TWIDTH)*12 [STI]
<i>NOTE : 5 and 6 are required only if ISUS = 0 or 2</i>	
DATA CARD 204	
1. AKF, linear front suspension load deflection rate	KSF/12 [STI]
2. AKFC, linear coefficient of the front suspension compression bumper term	KBS/12 [STI]
3. AKFCP, cubic coefficient of the front suspension compression bumper term	2*(KBS/12) [STI]
4. AKFE, linear coefficient of the front suspension extension bumper term	KBS/12 [STI]
5. AKFEP, cubic coefficient of the front suspension extension bumper term	2*(KBS/12) [STI]
6. XLAMF, ratio of conserved to absorbed energy in the front suspension bumpers	0.5 [Assumed]
7. OMEGFC, front suspension deflection at which compression bumper is contacted	-1.5 [Minimum]
.....	-3.5 [Maximum]
8. OMEGFE, front suspension deflection at which extension bumper is contacted	+3.0 [Minimum]
.....	+5.0 [Maximum]

Table 1(c). Summary of HVOSM Parameters and Data Conversions

DATA CARD 205	
1. AKR, linear rear suspension load deflection rate KSR/12 [STI]
2. AKRC, linear coefficient of the rear suspension compression bumper term KBS/12 [STI]
3. AKRCP, cubic coefficient of the rear suspension compression bumper term 2*(KBS/12) [STI]
4. AKRE, linear coefficient of the rear suspension extension bumper term KBS/12 [STI]
5. AKREP, cubic coefficient of the rear suspension extension bumper term 2*(KBS/12) [STI]
6. XLAMR, ratio of conserved to absorbed energy in the rear suspension bumpers 0.5 [Assumed]
7. OMEGRC, rear suspension deflection at which compression bumper is contacted -1.5 [Minimum]
 -3.5 [Maximum]
8. OMEGRE, rear suspension deflection at which extension bumper is contacted +3.0 [Minimum]
 +5.0 [Maximum]
DATA CARD 206	
1. CF, front viscous damping coefficient per side KSDF/12 [STI]
2. CFP, front suspension coulomb friction per side 10.0 lbs. [Assumed]
3. EPSF, front suspension friction null band 0.001 in/sec [Assumed]
4. CR, rear viscous damping coefficient per side KSDR/12 [STI]
5. CRP, rear suspension coulomb friction per side 10.0 lbs. [Assumed]
6. EPSR, rear suspension friction null band 0.001 in/sec [Assumed]
DATA CARD 207	
1. RF, auxiliary roll stiffness of the front suspension -(KTSF*12) [STI]
2. RR, auxiliary roll stiffness of the rear suspension -(KTSR*12) [STI]
3. AKRS, rear axle roll-steer coefficient 0.0
4. AKDS, zero order coefficient for change in wheel steer angle with suspension deflection 0.0 rad
5. AKDS1, first order coefficient for change in wheel steer angle with suspension deflection BR [STI]
6. AKDS2, second order coefficient for change in wheel steer angle with suspension deflection CR [STI]
7. AKDS3, cubic coefficient for change in wheel steer angle with suspension deflection 0.0
NOTE : AKRS is set to zero under the assumption of a fixed roll axis and required only if ISUS = 0 or 2.	
NOTE : The given function is at most parabolic in STI report. Therefore, AKDS3 is set to be zero. If AKDS3 is available, it can be used in the program.	

Table 1(d). Summary of HVOSM Parameters and Data Conversions

<p>DATA CARD 208</p> <ol style="list-style-type: none"> 1. XIPS, steering moment of inertia about the wheel steering axes 500.0 lb-squared sec/in 2. CPSP, steering system coulomb friction torque 600.0 lb-in 3. OMGPS, front wheel steer angle at which steering limit stops are engaged 0.4 rad 4. AKPS, stiffness of the steering limit stops effective at the front wheel steering axes 5000.0 lb-in/rad 5. EPSPS, friction lag in the steering system 0.075 rad/sec 6. front wheel pneumatic trail 1.5 in
<p>DATA CARD 209</p> <ol style="list-style-type: none"> 1. DELB, beginning value of wheel displacement for tables -5.0 in 2. DELE, end value of wheel displacement for tables ... +5.0 in 3. DDEL, increment value +1.0 in <p><i>NOTE : The parameters on card 209 may apply to four tables defining camber as a function of wheel displacement.</i></p> <p><i>NOTE: Card 209 and subsequent table cards (1209,2209,3209,and 4209) are not required if ISUS = 2.</i></p>
<p>DATA CARDS 1209 and 2209</p> <p>1.- 11. PHIC(I) (I=1,11) = -DF*DDEL-EF*DDEL*DDEL DF,EF [STI]</p> <p><i>NOTE: Following card 209, there are up to 2 tables containing [(DELE-DELB)/DDEL]+1 entries.</i></p> <p><i>NOTE: These cards determine the front wheel camber table which was derived from the coefficients given in STI (1992).</i></p>
<p>DATA CARDS 3209 and 4209</p> <p>1.- 11. PHIRC(I) (I=1,11) = -DR*DDEL-ER*DDEL*DDEL DR,ER [STI]</p> <p><i>NOTE: Following card 209, there are up to 2 tables containing [(DELE-DELB)/DDEL]+1 entries.</i></p> <p><i>NOTE: These cards determine the rear wheel camber table which was derived from the coefficients given in STI (1992). (required if ISUS = 1)</i></p>
<p>DATA CARD 210</p> <ol style="list-style-type: none"> 1. DAPFB, beginning suspension deflection for front anti-pitch coefficients table -5.0 in 2. DAPFE, end suspension deflection for front anti-pitch coefficients table +5.0 in. 3. DDAPF, increment value 0.5 in.

Table 1(e). Summary of HVOSM Parameters and Data Conversions

<p>DATA CARDS 1210, 2210 and 3210</p> <p>1.- 21. APF(I) (I=1,21) 0.1 lb/lb-ft [Assumed]</p> <p>NOTE : [(DAPFE-DAPFB)/DDAPF]+1 entries of front anti-pitch coefficient.</p>
<p>DATA CARD 211</p> <p>1. DAPRB, beginning suspension deflection for rear anti-pitch coefficients table -5.0 in. 2. DAPRE, end suspension deflection for rear anti-pitch coefficients table -5.0 in. 3. DDAPR, increment value +5.0 in.</p>
<p>DATA CARDS 1211</p> <p>1.- 21. APF(I) (I=1,21) 0.09 lb/lb-ft [Assumed]</p> <p>NOTE : [(DAPRE-DAPRB)/DDAPR]+1 entries of rear anti-pitch coefficient.</p>
<p>DATA CARD 300</p> <p>1. Tire title.</p>
<p>DATA CARD 301</p> <p>1.- 4. ITIR(I) (I=1,4), indicator to identify the sets of tire data to be used for the RF, LF, RR and LR tires, respectively 5. RWHJE, final deflection of the radial spring tire model = (RR*12+1)-(radius of the rim) RR [STI] 6. DRWHJ, increment of deflection of the force-deflection characteristic of the radial spring tire model. [STI]</p> <p>NOTE : RWHJE and DRWHJ must be provided if INDCRB = 1.</p> <p>NOTE : The number of force entries can be estimated by [(RWHJE)/(DRWHJ)]+1 and is limited to 35.</p>
<p>DATA CARD 1301</p> <p>1. AKT (from HVOSM), tire load deflection rate in quasi-linear range TSPRINGR/12 [STI] 2. SIGT, tire deflection at which the load deflection rate increases 0.8*RWHJE [Assumed] 3. XLAMT, multiplier of AKT used to obtain tire stiffness at large deflections 10.0 [Assumed] 4. A0, constant for tire side force vs. slip angle characteristics KA0 [STI] 5. A1, constant for tire side force vs. slip angle characteristics KA1 [STI] 6. A2, constant for tire side force vs. slip angle characteristics KA2 [STI] 7. A3, constant for tire side force vs. slip angle characteristics KA3 [STI] 8. A4, constant for tire side force vs. slip angle characteristics KA4 [STI] 9. OMEGT, multiplier of A2 at which tire side force characteristic variation with load is abandoned 1.0 [Assumed]</p> <p>NOTE : OMEGT is approximated as an average of the range 0.8 and 1.15 using the fact that it is necessary to avoid artificially large side forces under extreme loading.</p>

Table 1(f). Summary of HVOSM Parameters and Data Conversions

DATA CARD 302	
1. AMU (from HVOSM), nominal friction coefficient MUNOM [STI]
2. blank	
3. blank	
4. blank	
5. RW, undeflected tire radius (RR*12)+(SIGT/2) [STI]
6. blank	
7. blank	
8. blank	
DATA CARD 600	
1. initial condition title	
DATA CARD 601	
1. PHIO, initial vehicle roll angle 0.0 deg
2. THETAO, initial vehicle pitch angle 0.0 deg
3. PSIO, initial vehicle yaw angle initial impact angle
4. PO, initial vehicle angular velocity about X-axis 0.0 deg/sec
5. QO, initial vehicle angular velocity about Y-axis 0.0 deg/sec
6. RO, initial vehicle angular velocity about Z-axis 0.0 deg/sec
7. PSIFIO, initial front wheel steering angle 0.0 deg
8. PSIFDO, initial front wheel steer angular velocity	. 0.0 deg/sec
DATA CARD 602	
1. XCOP, initial X coordinate of the sprung mass C.G. from the space axes 0.0 in.
2. YCOP, initial Y coordinate of the sprung mass C.G. from the space axes -217.25 in.
3. ZCOP, initial Z coordinate of the sprung mass C.G. from the space axes -HS*12 [STI]
4. UO, initial longitudinal velocity of the vehicle C.G. along the vehicle axes initial impact speed
5. blank	
6. blank	

Although table 1 indicates significant use of data from Allen et al. (1992), it should be pointed out that a great deal of data from other sources, such as Ross and Sicking (1986) and Council et al. (1988), was also used indirectly to determine appropriate ranges of values for various vehicle and tire parameters.

Despite the use of sources such as Allen et al. (1992), Ross and Sicking (1986), Council et al. (1988), Segal and Ranney (1978), and Heydinger (1980), some vehicle parameters were not available in the literature. For these parameters, reasonable values were approximated and then

subsequently examined using parametric studies. The results of the parametric studies were used to determine whether the simulation results were especially sensitive to the choice of vehicle parameters.

Using this type of sensitivity analysis, it was found that the values of σ_T (i.e. σ_T of figure 4) and Ω_C (i.e. Ω_C —evaluated for the front axles, called Ω_{FC} —of Figures 7 and 8) were key parameters in peak trajectory height prediction. The peak elevations of the bumper trajectories computed using HVOSM simulations are sensitive to the choice of σ_T and Ω_{FC} . The value of σ_T indicates the tire deflection at which the tire stiffness increases abruptly (this is an attempt to represent the combined tire and rim stiffness during an impact). The value of Ω_{FC} is the suspension deflection at which the front wheel rubber bumper stops are engaged. Engaging these bumper stops during an impact will also result in an abrupt increase in apparent suspension stiffness.

Based on the extremely widespread use of radial tires in today's passenger vehicle fleet, it was decided that tire parameters used in the HVOSM simulations performed for this project would make use of parameters representative of radial tire characteristics. It should be noted that the term "radial tire" used at this point is not the same as the term "radial spring tire model" used previously to describe the HVOSM method of modeling tire stiffness. Here, the term "radial tire" is used to distinguish this type of tire from "bias ply" tires that were more commonly used a few decades ago.

Based on the assumption of the use of radial tires, it was decided that the value of σ_T that would be used was $\sigma_T = 0.8 * R_{WHJE}$. The reader is referred to CARD 301 in table 1 for a description of R_{WHJE} . This choice of σ_T indicates that the tire stiffness will begin increasing

substantially after the tire has deformed to 80% of its maximum possible radial deflection. At that point, it is assumed that rim of the wheel assembly comes into contact with the curb and the stiffness of the tire and rim combination increases significantly. To approximately reflect this increase in stiffness, a value of 10.0 is used for the λ_{XLAMT} stiffness scaling factor (i.e. the λ parameter of figure 4).

The value of Ω_{FC} was also found, through sensitivity analyses, to be a key parameter in the prediction of peak vertical trajectory height. Rather than using a *single* representative average value of Ω_{FC} for each vehicle, it was decided that a *range* of values should be used for each vehicle. Thus, for each vehicle, simulations were performed using two values of Ω_{FC} , namely Ω_{FC}^{\min} and Ω_{FC}^{\max} . Trajectory plots were then plotted for each choice of Ω_{FC} on the same plots so that the worst case condition could always be readily identified. For all vehicles except the Chevy Cavalier, the values used were : $\Omega_{FC}^{\min} = 1.5''$ and $\Omega_{FC}^{\max} = 3.5''$. For the Chevy Cavalier, more accurate data for Ω_{FC} was actually *measured* by the authors and therefore a narrower range of Ω_{FC} values was used: $\Omega_{FC}^{\min} = 1.5''$ and $\Omega_{FC}^{\max} = 2.0''$.

Appendix A of this report includes listings of the HVOSM vehicle input data blocks used in the impact simulations.

7. CURB AND BERM IMPACT SIMULATIONS USING HVOSM

The primary goal of this project was to generate vehicle bumper trajectory plots for curb and berm impacts at various impact speeds, impact angles, and for various types of vehicles. Limited trajectory data of this type is given in AASHTO (1977) where the trajectory parameters indicated in figure 12 are given for various types of curb and berm profiles (see also NCHRP-

150, 1974 and AASHTO, 1996). Trajectory plots and trajectory data of this type can then be used to evaluate appropriate set back distances for guide rails that are placed adjacent to curbs or berms. The goal of this work then was to generate complete trajectory plots for a wide range of impact conditions using a specified set of curb and berm profiles and using the set of vehicles listed in Section 5 of this report. For each choice of curb and vehicle, a large number of impact angles and speeds were then simulated using HVOSM. The results were then plotted in forms very similar that of figure 12.

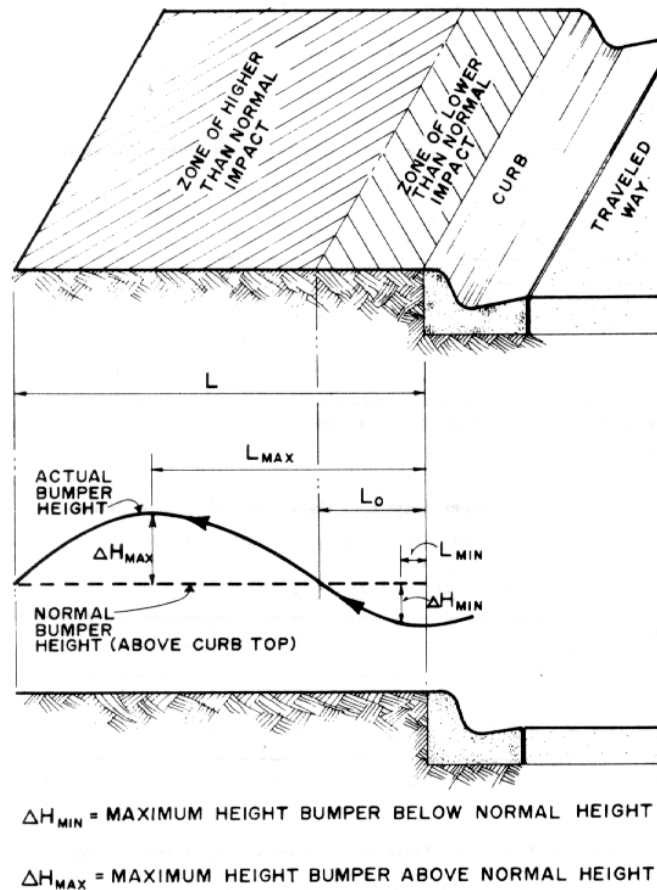

Figure 12. Design Parameters for Vehicle Encroachments on Curbs
(taken from AASHTO 1977)

Nine different curb and berm profiles were included in the HVOSM impact simulations

performed. They were:

1. 2" Curb
2. 4" Curb
3. 6" Curb
4. 8" Curb
5. Sloped Curb
6. Berm 6-to-1 slope, 4" rise
7. Berm 6-to-1 slope, 6" rise
8. Berm 6-to-1 slope, 12" rise
9. Berm 10-to-1 slope, 3.6" rise

The approximate shapes of these profiles are shown in figure 13. The exact dimensions of each profile are given in Appendix B which contains listings of the HVOSM curb and berm profile data blocks that were used.

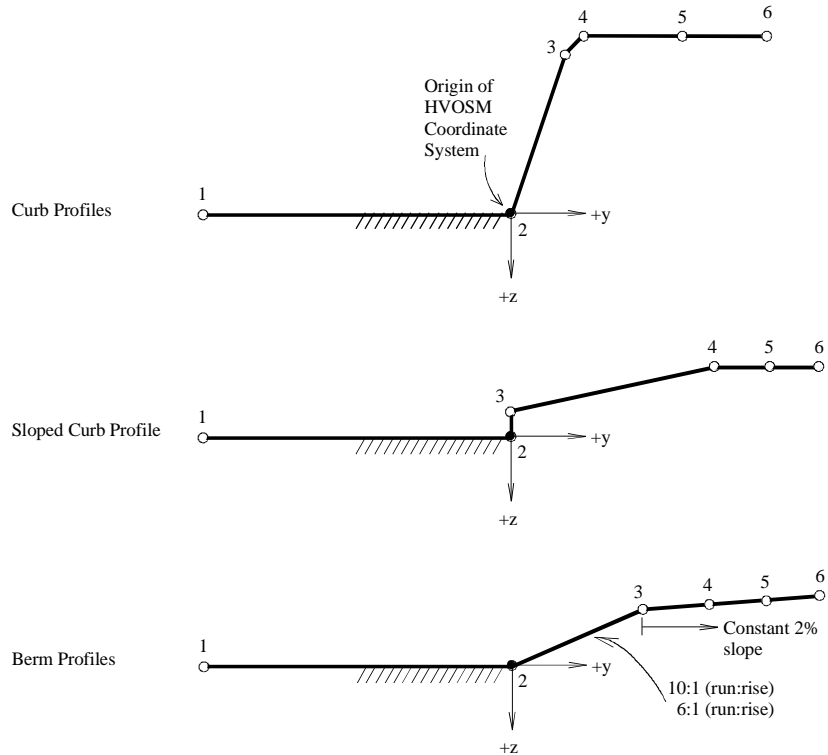

Figure 13. Curb and Berm Profiles Modeled for Vehicle Impact Simulations

For each of the nine curb profiles considered, impact simulations were performed for each of the six vehicles considered in this study. For each combination of curb/berm profile and vehicle type, the simulations listed in table 2 were then performed.

Table 2. Complete Set of Impact Simulations Performed for Each Combination of Curb/Berm Profile and Vehicle Type

Vehicle Ω_{FC}	Impact Speed (mph)	Impact Angle (degrees)
Ω_{FC}^{\min}	30	12.5, 15.0, 17.5, 20.0, 25.0
	40	12.5, 15.0, 17.5, 20.0, 25.0
	50	12.5, 15.0, 17.5, 20.0, 25.0
	60	12.5, 15.0, 17.5, 20.0, 25.0
	70	12.5, 15.0, 17.5, 20.0, 25.0
Ω_{FC}^{\max}	30	12.5, 15.0, 17.5, 20.0, 25.0
	40	12.5, 15.0, 17.5, 20.0, 25.0
	50	12.5, 15.0, 17.5, 20.0, 25.0
	60	12.5, 15.0, 17.5, 20.0, 25.0
	70	12.5, 15.0, 17.5, 20.0, 25.0

The quantities of the various impact simulation parameters that were considered in this study were then:

- 6 : Vehicle types
- 2 : Vehicle suspension values (Ω_{FC}^{\min} and Ω_{FC}^{\max})
- 9 : Curb and berm profiles
- 5 : Impact speeds
- 5 : Impact angles

This resulted in a total of $6*2*9*5*5=2700$ impact simulations that were performed using HVOSM. For each choice of vehicle type, profile, speed and angle, the trajectories predicted by the simulations performed using both Ω_{FC}^{\min} and Ω_{FC}^{\max} were plotted on the same bumper trajectory plot. This was done because both parameters represent the same vehicle, just different

possible values of Ω_{FC} for that vehicle. Thus, there were $2700/2=1350$ actual trajectory plots generated (with two curves per plot). Grouping these plots by vehicle type, we arrive at $1350/6=225$ plots per vehicle type. The resulting plots for each vehicle type are included in Volumes II through VII of this report. Additional information regarding the actual calculation of trajectory plot data is given in the following sections.

7.1 COORDINATE SYSTEMS USED IN HVOSM

Two coordinate systems are used in the mathematical descriptions of vehicle motion in HVOSM. The first is a *global* right-handed coordinate system that is fixed in space. The second is a *vehicle* coordinate system that is “attached” to the body of the vehicle as it moves through space (e.g. following a trajectory path after impacting a curb). Steering angles of the front wheels may vary with respect to the fixed space coordinates as the vehicle moves through space but can simultaneously be constant with respect to the vehicle coordinate system if the steering angle is not changing during the vehicle’s motion.

In terms of computing vehicle bumper trajectories after impact events, as is of interest in the current research project, we are primarily concerned with the global coordinate system. HVOSM simulations report the X, Y, and Z coordinates and the ψ (yaw), θ (pitch), and ϕ (roll) rotation angles (see figure 14) of the center of gravity of the sprung mass (vehicle body) as a function of time. The yaw angle corresponds to angle that the vehicle centerline makes with the edge line of the curb or berm being impacted. That is, the initial yaw angle of the vehicle is equal to the impact angle being simulated.

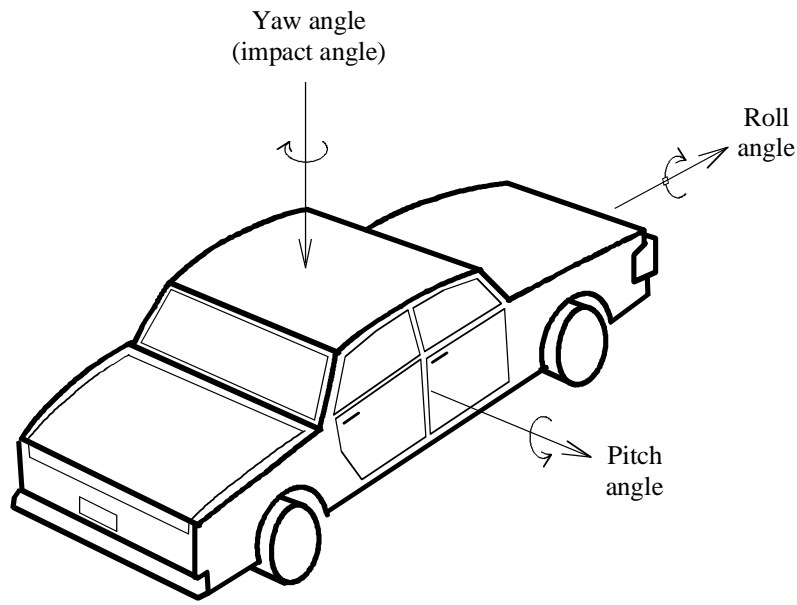

Figure 14. Yaw, Pitch and Roll Angles Used in HVOSM

The X, Y, and Z coordinates alone are sufficient plot the trajectory of the center of gravity of the vehicle *body*. However, this is not the trajectory path that is of interest to us. Instead, we are concerned with the trajectory of the vehicle's front *bumper*. Thus a coordinate conversion process is necessary to generate the desired trajectory data.

7.2 VEHICLE BUMPER DIMENSION AND LOCATION DATA

Of primary interest in this study was the determination of vehicle *bumper* trajectories after curb and berm impacts. A “bumper trajectory” is the plot of the motion through space of a particular point on the vehicle's bumper after the vehicle's tires strike a curb or berm. In this study, the point at the mid-height of the end of the bumper (or at the corner of the bumper for wrap-around bumpers) was used for the generation of trajectory plots. The right corner of the vehicle's front bumper was assumed to be the point which would normally come in contact with a guide rail during an impact. Thus, the point at the mid-height of this end/corner of the bumper was considered to be a representative point in terms of trajectory plot evaluations.

Since bumper location data is not necessary data for HVOSM simulations (i.e. it is not required in the HVOSM input file), this type of data was not readily available from the literature sources used to obtain the other vehicle characteristics. Thus these parameters had to be measured on actual vehicles. Table 3 lists the measurements that were taken by the authors to provide this necessary information for bumper trajectory calculation.

7.3 COMPUTING BUMPER TRAJECTORY DATA FROM HVOSM TRAJECTORY DATA

In order to compute the trajectory of the right corner of the front bumper of the vehicle, we must use a coordinate conversion process to transform the data reported by HVOSM into the form we require. We do this by first establishing a local coordinate system R, S, T for the vehicle. This coordinate system is similar to the global X, Y, Z coordinate system used in the HVOSM simulation except that the origin of the R, S, T system is at the center of gravity of the sprung mass. Thus the coordinates in R, S, T “space” of the sprung mass center of gravity is (0,0,0).

Table 3. Measured Bumper Location Data and Ω_{FC} Data

Vehicle	1	2	3	4	5	6
Ford Escort	34.5”	33”	16”	4”	29”	n/a
Honda Civic	30”	25.5”	15”	3.75”	30.25”	n/a
Chevy Cavalier	33”	32”	17.5”	2.5”	29”	1.5”-2”
Plymouth Voyager	31”	29”	19”	3”	34”	n/a
Chevy Pickup	29.5”	29.5”	15”	7”	37.5”	2.75” - 3”
Jeep Wrangler	25”	25”	17.3”	4.3”	26.75	n/a

Parameter legend:
1 – Longitudinal distance from center of front axle to bumper at centerline of vehicle
2 – Longitudinal distance from center of front axle to bumper at end (corner) of bumper
3 – Vertical clearance from ground to bottom edge of end (corner) of bumper
4 – Approximate vertical depth of bumper
5 – Half-width of bumper (lateral distance from centerline of vehicle to end of bumper)
6 – Front suspension “bump stop” distance in compression (Ω_{FC})

The $(X, Y, Z, \psi, \theta, \phi)$ trajectory data reported by HVOSM is then the path that the origin of the new R, S, T coordinate system takes as the vehicle moves through space. We then establish the coordinates of the right corner of the front bumper in the new R, S, T coordinate system (i.e. relative to the center of gravity of the sprung mass). This process illustrated in figure 15.

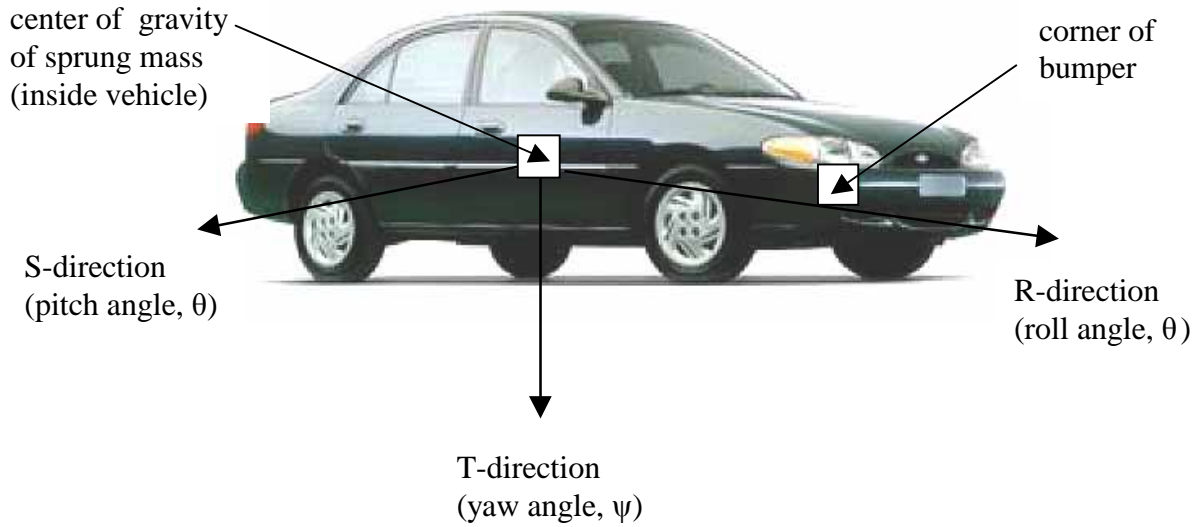

Figure 15. Local Coordinate System R, S, T and Location of Corner of Front Bumper

If we denote the local R, S, T coordinates of the corner of the bumper as $(R_{\text{bumper}}, S_{\text{bumper}}, T_{\text{bumper}})$ and the global X, Y, Z coordinates of the sprung mass center of gravity as $(X_{\text{sprung mass}}, Y_{\text{sprung mass}}, Z_{\text{sprung mass}})$, and we have the three rotation angles ψ , θ , and ϕ available, then we can perform a coordinate conversion of the form

$$\begin{Bmatrix} X_{\text{bumper}} \\ Y_{\text{bumper}} \\ Z_{\text{bumper}} \end{Bmatrix} = \begin{Bmatrix} X_{\text{sprung mass}} \\ Y_{\text{sprung mass}} \\ Z_{\text{sprung mass}} \end{Bmatrix} + \begin{bmatrix} \psi \text{ yaw} \\ \text{rotation} \\ \text{matrix} \end{bmatrix} \cdot \begin{bmatrix} \theta \text{ pitch} \\ \text{rotation} \\ \text{matrix} \end{bmatrix} \cdot \begin{bmatrix} \phi \text{ roll} \\ \text{rotation} \\ \text{matrix} \end{bmatrix} \cdot \begin{Bmatrix} R_{\text{bumper}} \\ S_{\text{bumper}} \\ T_{\text{bumper}} \end{Bmatrix}$$

to compute the coordinates $(X_{\text{bumper}}, Y_{\text{bumper}}, Z_{\text{bumper}})$ of the bumper in the global coordinate system. The coordinates $(X_{\text{bumper}}, Y_{\text{bumper}}, Z_{\text{bumper}})$ are the coordinates of the right corner of the vehicle's front bumper relative to the curb. In all of the HVOSM simulations performed in this study, the origin of the X, Y, Z global coordinate system was placed at the base of the curb face or berm face (see figure 13). Thus the value Y_{bumper} is the *horizontal* (or lateral) distance from the face of the curb to the corner of the bumper and the value $-Z_{\text{bumper}}$ is *vertical* distance from the base of the curb to the mid-height of the corner of the bumper. The (-) sign on Z is due to the fact that the HVOSM Z-axis is positive in the downward direction rather than in the upward direction.

To create bumper trajectories of the form shown in figure 12, we plot the coordinates $(Y_{\text{bumper}}, -Z_{\text{bumper}})$ for the bumper for each time step in the HVOSM analysis. This produces a *lateral trajectory plot* (a trajectory plot in the lateral y-direction) in which the X_{bumper} value is not of interest. A post-processing program was written as part of this project to convert the $(X, Y, Z, \psi, \theta, \phi)$ data reported by HVOSM into $(X_{\text{bumper}}, Y_{\text{bumper}}, Z_{\text{bumper}})$ bumper trajectory data. The resulting trajectory plots, computed for each vehicle type using this coordinate conversion process, are presented in Volumes II through VII of this report. An example of the type of trajectory plots presented in Volumes II through VII is given in figure 16.

8. ACCURACY AND LIMITATIONS OF HVOSM IMPACT SIMULATION

In order to evaluate the accuracy of the HVOSM simulation results, past projects that have made use of HVOSM for curb and berm impact simulation were consulted. The NCHRP-150 (1974) report—which is referred to in the design guideline publications AASHTO (1977) and AASHTO (1996)—includes comparisons between full scale crash test data and data pre-

dicted by HVOSM simulation. HVOSM validation through comparison between HVOSM simulation data and corresponding full-scale crash testing data has also been done by DeLeys and Segal (1973) and by Holloway, Sicking, and Rosson, (1994). In the latter report, the vehicles used in the crash testing and simulation were much more modern than those of used in the older NCHRP-150 report and therefore the results of the testing are more applicable to the modern vehicle fleet of interest. In addition, the impact speeds and angles considered by Holloway et al. are very similar to those considered in the present study. The results from their study indicated that the HVOSM simulations were reasonably accurate for the curb profiles, impact speeds, and impact angles considered.

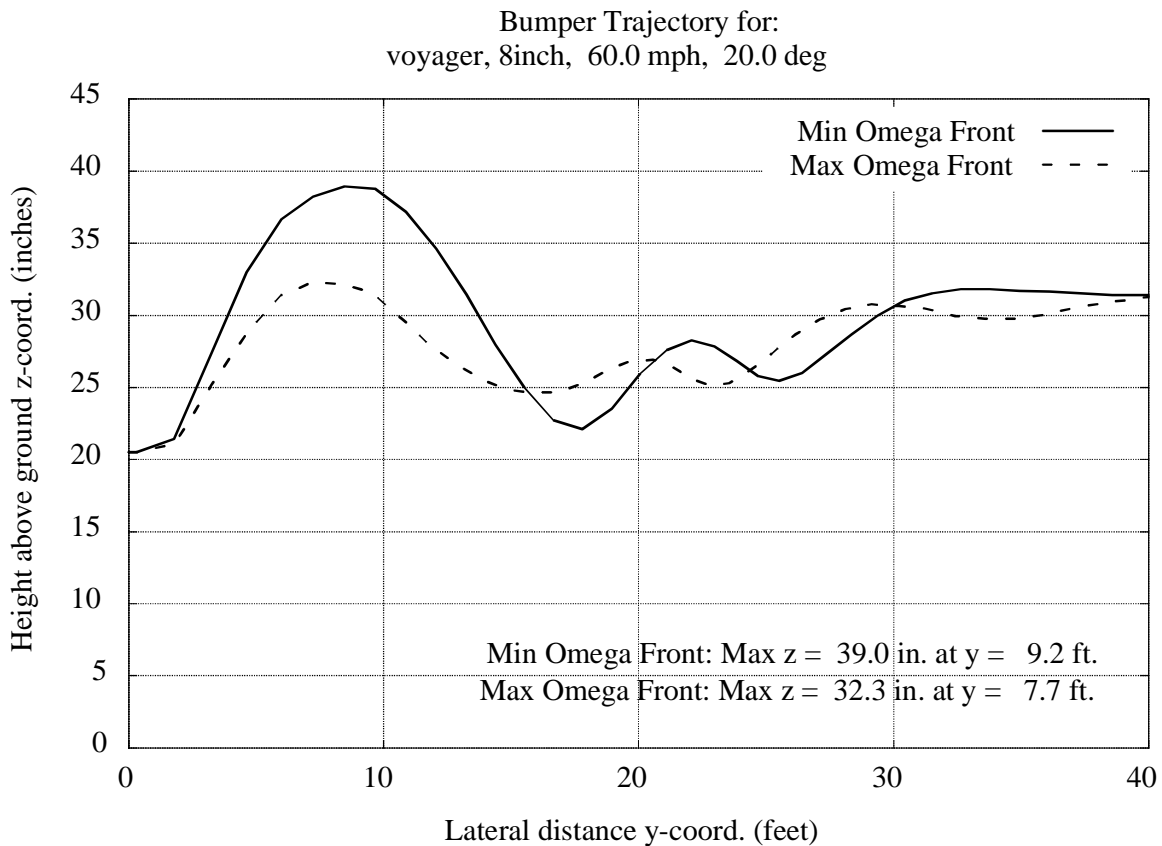

Figure 16. Typical Lateral Trajectory Plot

The authors state that “the bumper trajectory comparisons were very favorable and in most cases the simulated trajectories were within 1-5 inches of the full-scale test bumper trajectories” (Holloway et al., pg.71).

The maximum curb height tested by Holloway et al. was 6 inches whereas the maximum curb height simulated in the present project was 8 inches. It is possible that HVOSM may not be as accurate for 8 inch curbs as it is for a 6 inch curbs. The reason for this statement is that for larger curbs, more severe wheel damage is likely to occur during the impact. Holloway et al. noted some wheel damage during full scale crash testing (see figure 17). The thin disk, radial spring tire and wheel model used by HVOSM will not be able to accurately model the energy dissipation that occurs during rim damage or the changing stiffness of the rim during deformation. In addition, the highest impact speed considered by Holloway et al. was 55mph whereas the highest impact speed considered in the present study was 70 mph.



Figure 17. Wheel Damage after Full Scale Crash Test
(photo taken from Holloway, J.C., Sicking, D.L., Rosson, B.T., 1994)

It is clear that more severe wheel damage will be expected at higher impact speeds and therefore the results of HVOSM simulations for high speed impacts will be less accurate.

For high speed impact situations, there is also another limitation of HVOSM that could limit the accuracy of the simulation results: suspension damage. Impacts on large curbs at high speeds may result in damage to the vehicle's suspension system. HVOSM has no method of accounting for such damage and therefore the results from simulation may vary substantially from those of full scale crash testing under corresponding conditions.

There are also other limitations of HVOSM that are relevant to this study. The HVOSM tire model, as used in this study, has no damping. The tire is modeled as a thin disk of radial springs without any damping. Other researchers (e.g Perera 1987) have modified the HVOSM tire model to incorporate damping effects. However, even if damping effects are included, the tire model is still represented as a thin disk. The thin disk modeling approximation results in the fact that HVOSM is generally unable to produce accurate results for very shallow impact angles (e.g. less than approximately 10 degrees). For this reason, in this study the smallest impact angle simulated was 12.5 degrees.

However, despite its known limitations, the HVOSM model is still capable of predicting accurate impact data assuming that it is applied to *appropriate* impact situations. It was noted above that the accuracy of HVOSM results will likely decrease with increasing speed. However, most curbs are placed along roadways where the vehicle speeds are far less than the maximum 70 mph speed examined in this study. Therefore, the HVOSM results for impacts at more moderate speeds, e.g. below 40-50mph, and for moderate angles (larger than 10 degrees) should be expected to be reasonably accurate.

9. CURB AND BERM IMPACT MODELING USING FEA

Finite element analysis (FEA) is, like HVOSM, a numerical simulation technique, however the FEA approach to system modeling (e.g. vehicle or barrier modeling) is very different from HVOSM. The FEA approach is extremely general. Virtually any physical system can be modeled and analyzed as long as the geometry, mass, material properties, etc. of the system under consideration are well known. This differs from HVOSM in that HVOSM is a simulation code that was developed specifically for analyzing vehicle stability, handling, and curb impact situations. It's range of applications is fairly narrow. Thus, the FEA method offers much more flexibility and accuracy in terms of the types of analysis or simulation situations that can be considered than does HVOSM. However, FEA modeling, like HVOSM modeling, also requires substantial model development effort and model validation.

9.1 MOTIVATION FOR USING FEA FOR CURB AND BERM IMPACTS

It is desirable to utilize the FEA method for curb and berm impacts because this method offers several advantages over the HVOSM method previously described in this report. In particular, the FEA method offers the ability to model the vehicle suspension much more accurately than is possible in HVOSM. Also, not only can the suspension be modeled more accurately, but failure of suspension components during high speed impacts can be accounted for using FEA whereas this is not possible using HVOSM.

Wheel modeling using FEA is also quite different than that used in HVOSM. There is no thin disk assumption in the FEA method as there is in HVOSM. The tire, rim, and other wheel components can be modeled very accurately to reflect the actual stiffness of the tire and rim. Deformations of the rim that occur as a result of impact can also be accurately captured during the analysis whereas this cannot be accomplished with HVOSM.

Contact between the vehicle body and roadside hardware, such as guide rails or barriers, can also be accurately modeled using FEA. HVOSM makes use of a crude crush model to represent the stiffness of the vehicle body during impacts with rigid barriers and does not have the capability at all to represent impacts with *deformable* barriers such as guide rails. In FEA, however, components of the vehicle near the contact area can be accurately modeled and therefore accurate predictions of interaction between vehicles and barriers can be accomplished. In addition, impacts with deformable barriers as well as rigid barriers can be modeled using FEA.

9.2 FEA IMPACT SIMULATION CODES

While the FEA method is itself very general, not all FEA codes (programs) have all of the features needed for vehicle impact simulation. Vehicles, barriers, guide rails, and other roadside safety hardware are all physical systems made from materials such as steel, aluminum, plastic, foam, rubber, and concrete. Most of these materials have well known physical properties; e.g. how stress and strain in the materials are related and similar issues. However, in order for a FEA code to be used in vehicle impact simulation, it must be able to do more than just take material properties and loads (forces) into account. For impact simulation, the FEA code used must also be able to handle dynamic effects, nonlinear material properties, large displacements, large rotations, and contact (among other things).

Dynamic effects must be included for the same reasons that they are included in HVOSM, i.e. because vehicle impacts are relatively high speed events and the inertial (dynamic) properties of the vehicle will play a role in determining the motions (e.g. trajectory) of the vehicle during and after the impact. Nonlinear effects are necessary because during an impact, many parts of the vehicle (and certain roadside hardware items such as guide rails, posts, etc.) will be stressed or strained to their failure levels. Even parts that do not actually fail will often be

deformed so badly that their material behavior can no longer be adequately represented using classical linear FEA. In addition, many modern materials are nonlinear even at very low load (stress) level. Thus, the ability to accurately handle nonlinear material behavior is necessary.

The need for the code to be able to handle large displacements, large rotations, and contact arise from the large degree of deformation (crushing) that occurs during an impact. Even in performing curb impact simulations for purposes of predicting vehicle trajectories—a situation in which the body of the vehicle does not necessarily crush—the suspension may fail at high speed, and the wheel assemblies undergo a large level of deformation. If guide rails are included in the curb simulations as well, then crushing of portions of the vehicle body will certainly occur. In order to be able to properly simulate these effects, the FEA code used must handle large displacements and large rotations.

In addition, modeling *contact* between the various parts of the objects being simulated is absolutely necessary. Contact algorithms are methods that FEA codes use to detect and account for contact between various elements of the simulation. Examples of contact include a vehicle bumper coming into contact with a steel guide rail; a tire, rim, or suspension component coming into contact with a curb; a piece of sheet metal on the vehicle body coming into contact with a separate vehicle component inside the vehicle; or a piece of metal coming into contact with itself due to very large bending deformations (e.g. when a component buckles).

While there are many FEA codes in existence today, only a small percentage of those codes have all of the features necessary for vehicle impact modeling. At present, in the U.S.A., the FEA code most commonly used by the roadside safety community is LS-DYNA3D (LSTC 1997). LS-DYANA3D provides all of the requisite features for vehicle impact modeling and has the additional advantage that it has gained rather widespread acceptance. As a result, there are

several vehicle models available to the research community that are already in LS-DYNA3D “format”, i.e. they are modeled using the features found specifically in LS-DYNA3D. One of LS-DYNA3D’s primary strengths that is relevant to impact modeling is the large array of contact algorithms that are available when using the code.

In the present study, LS-DYNA3D was used as the primary FEA analysis tool for the simulations performed. The LLNL DYNA3D code was also used for selected simulations. The LLNL (Lawrence Livermore National Laboratories) DYNA3D code was the predecessor to LS-DYNA3D. Although DYNA3D is still maintained by LLNL, it has not kept pace with LS-DYNA3D in terms of the introduction of new features for impact modeling and at present it is not as powerful or as flexible as LS-DYNA3D.

9.3 VEHICLE MODELING FOR FEA

It is beyond the scope of this report to give a complete and detailed description of vehicle modeling using FEA, however, an overview of the approaches employed will be presented. In modeling any structure for FEA—whether it be a vehicle, guide rail, barrier, sign support structure, or otherwise—the first step is to *discretize* the structure. Discretization is the process of taking a large object and representing it using a large number of small elements. These small elements may be flat surface elements or thick solid elements. The coordinates of the vertices of the elements (called nodes) must be known, and material properties for the elements must be known. The coordinates of the nodes determine the geometry of the object being modeled and the material properties of the elements determine the behavior of the object during rigid body motion and during contact (impact) with other objects.

Most (or all) of the data needed to model a vehicle’s geometry will be known by the automotive company that designed, manufactured, and sold the vehicle. However, due to fear of

liability litigation arising from the release of such data, automobile manufactures do not generally release any of this data. As a result, all of the coordinate data must be measured from actual vehicles and converted back into digital coordinate data form. The National Crash Analysis Center (NCAC) at George Washington University (GWU) has facilities setup specifically for the purpose of measuring and discretizing vehicles to obtain coordinate data for FEA modeling. An example of their work, in which a vehicle door has been discretized is shown in figure 18.

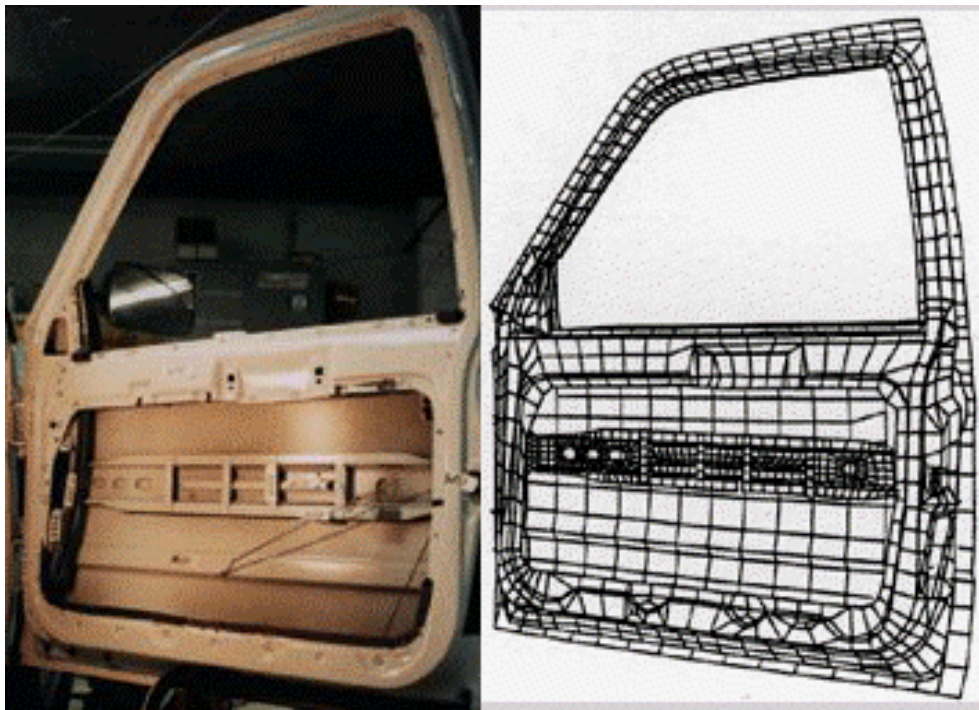

Figure 18. Photograph of Vehicle Door and Measured Discretized Mesh (photograph and mesh prepared and produced by NCAC—GWU)

In addition to obtaining coordinate (geometry) data, material properties and connectivity of the vehicle must also be known or measured. A typical vehicle will have many different materials used in its construction. The properties of the materials that have the greatest influence on the vehicle behavior under consideration must be known in order to model that impact situation using FEA. Connectivity of the various components must also be known and must be

modeled appropriately for the impact situation of interest. For example, in this study, it was found that the manner in which the wheel assemblies (tire, rim, etc.) are connected to the rest of the vehicle was very important for curb impact modeling. This same connectivity is less important for other types of impact.

Due to the amount of effort that must be invested in creating new vehicle models for FEA simulation, the roadside safety community has shared the vehicle models that are in existence. Many of these models have been developed by the NCAC and are available to other individuals working in the FEA impact simulation area. The distribution of these models to other researchers also results in more widespread use, testing, and enhancement of these models. Also, other institutions in addition to NCAC, such as universities, research centers, and transportation related agencies have also contributed to the collection of vehicle and roadside hardware models that are available today.

10. PRELIMINARY CURB IMPACT SIMULATION RESULTS USING FEA

The final phase of this project consisted of performing preliminary curb impact simulations using available FEA vehicle models. The intent of this phase was to evaluate the applicability of these vehicle models—which are commonly used in barrier or frontal impact simulations—for the simulation of curb (and berm) impacts.

The first vehicle evaluated was the Ford Festiva (820C) vehicle shown in figure 19. The FEA model for this vehicle was obtained from NCAC’s FEA vehicle model archive. The curb was modeled using LS-DYNA3D “rigid wall” (also called “stone wall”) surfaces. The vehicle model was then combined with the curb model using the LS-INGRID finite element preprocessor. An initial impact angle and speed were assigned to the vehicle model and the analysis was then performed using LS-DYNA3D. The results revealed that this vehicle model is not appropri-

ate for curb impact simulation. The tire model is far too coarsely meshed, too stiff, and was likely never intended to be used in curb impact situations. Also, the vehicle's suspension is not adequately modeled for purposes of simulating curb impacts. This vehicle model is primarily meant for frontal impact situations and would need significant modifications before it could be used for curb impact applications.

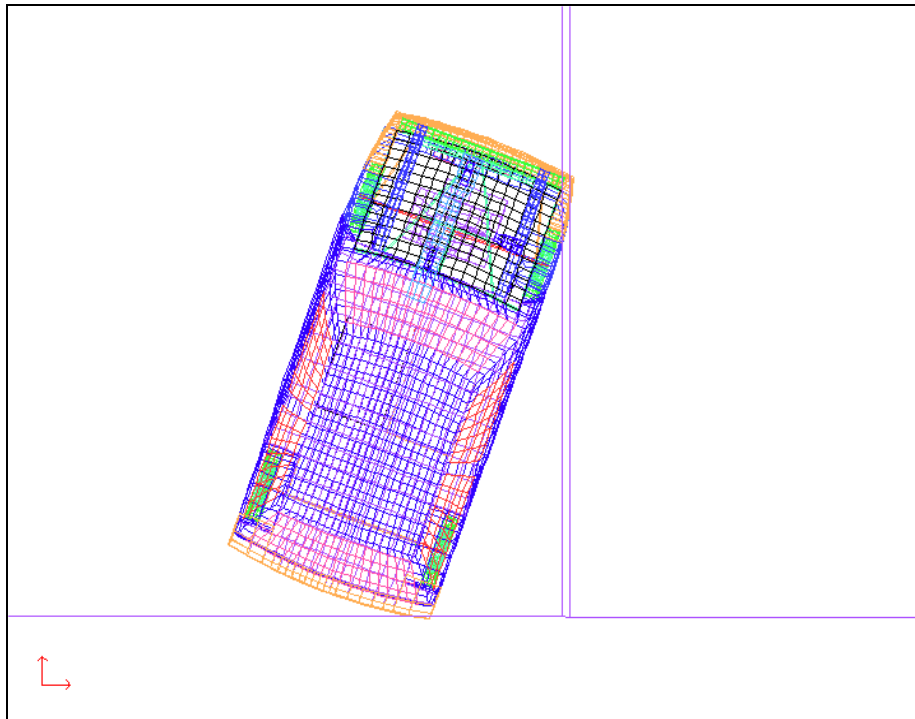

(a)



(b)

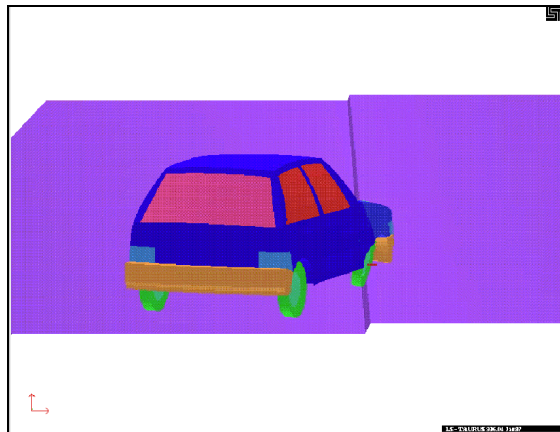

(c)

Figure 19. Ford Festiva FEA Simulation Results

The next vehicle model evaluated was the Chevy C2500 reduced resolution pickup truck model developed by NCAC (see figure 20). This model has a realistic and fairly sophisticated suspension model. The tires are modeled using LS-DYNA3D airbag elements to create internal pressure inside the tire's shell. The overall resolution (i.e. refinement of mesh density) of both

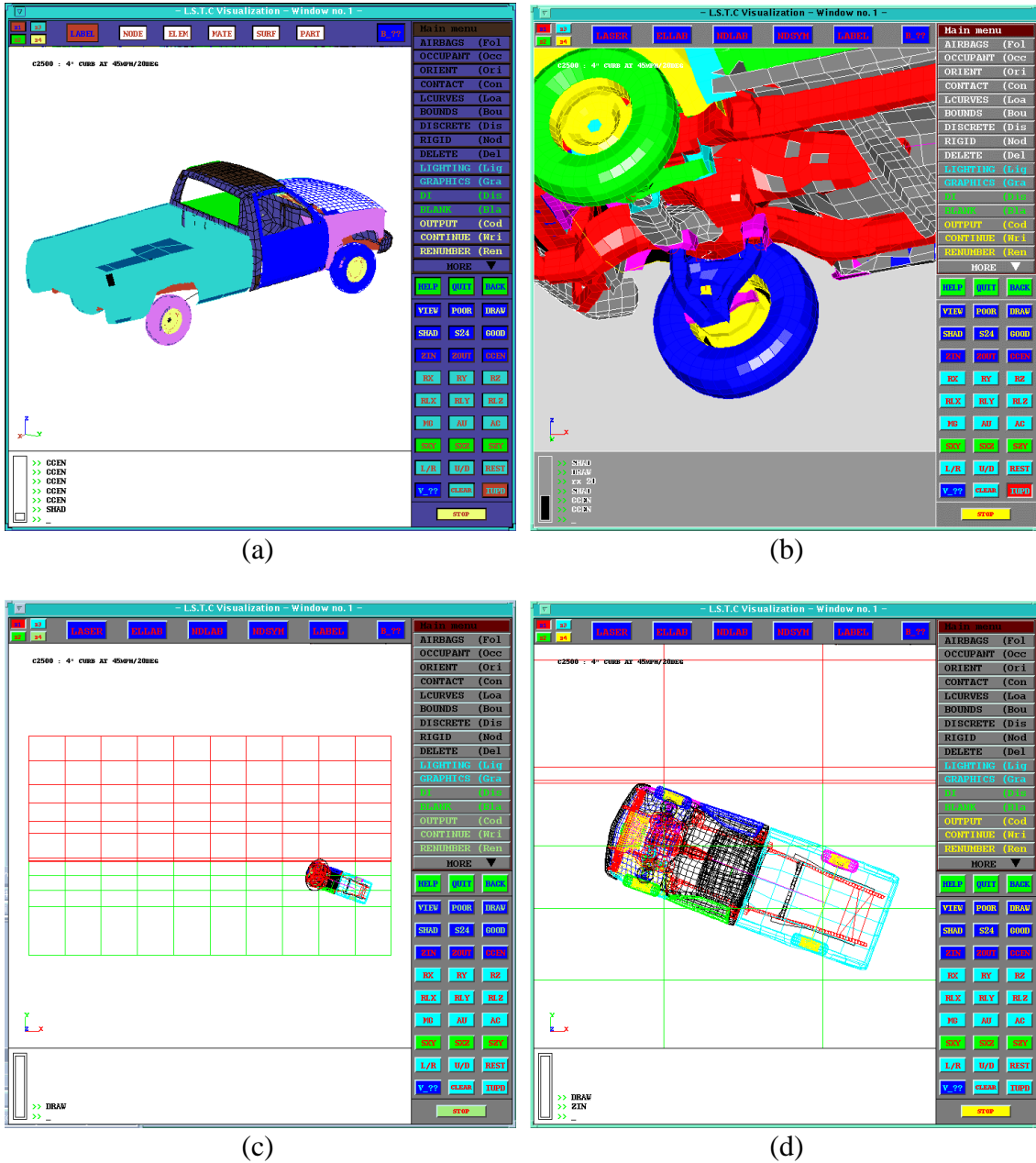

Figure 20. Setting Up The Chevy C2500 FEA Simulation Runs

the tires and rims is much higher than that of the Ford Festiva model. However, the wheel assemblies in this model do not *roll*. For some impact situations involving rigid barriers and for frontal impact simulation conditions, the fact that the tires do not roll is less significant. However, for curb impact simulation, the fact that the tires do not roll is very significant. Some results from the simulations performed using this vehicle model are shown in figure 21. Without the ability to roll, the tires of the vehicle model are forced to slide up onto the curb. While this may be a realistic situation for some non-tracking impact modes where the tires are locked against rotation by the brakes, it is not realistic for most curb impacts. Also, it is impossible to obtain useful vehicle trajectory data using this model because the truck is unable to properly “climb” the curb as would be the case in an actual tracking curb impact.

Recently, the author has been in contact with the staff of NCAC and has learned that a newer version of this truck model has been developed in which the tires are able to roll correctly. The author has obtained a copy of this model and it appears that this new model will in fact be very appropriate and useful for curb impact trajectory computation using FEA simulation.

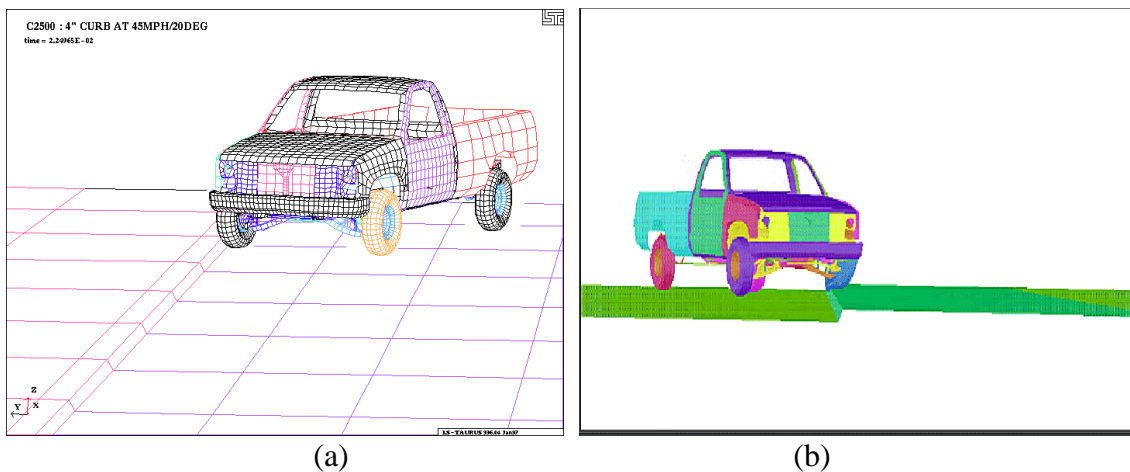

Figure 21. Chevy C2500 FEA Simulation Results

The final FEA model considered in this project was the bogie model developed by LLNL that is shown in figure 22. This bogie has a reasonably sophisticated suspension system and has a tire model similar to that of the NCAC C2500 pickup tire model. However, the wheel assemblies on this model roll correctly. Thus, this was an ideal model to determine if FEA simulation could be used for curb impact trajectory computation.

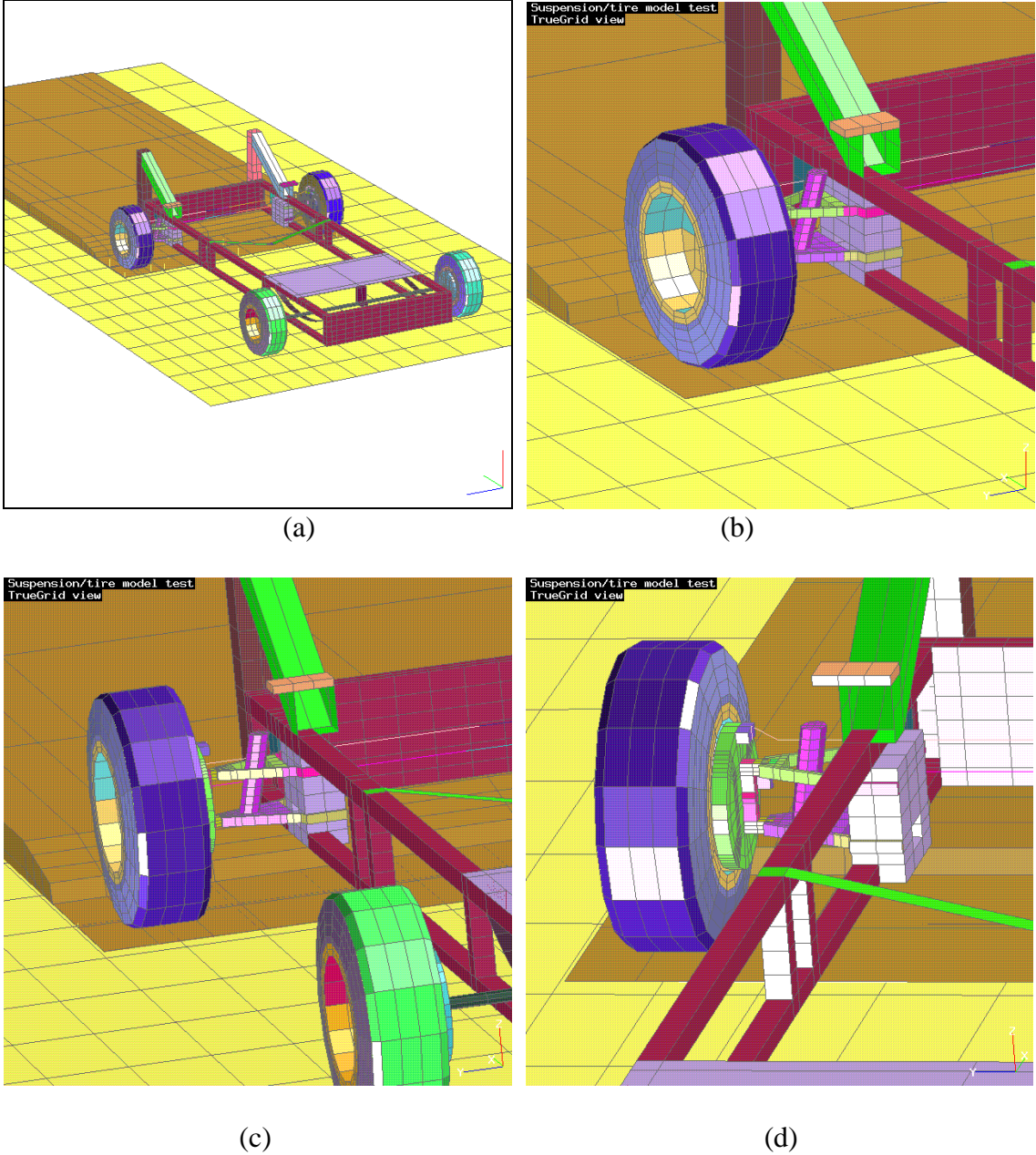

Figure 22. Setting Up the LLNL Bogie Simulation Runs

The results of test simulations performed using this model revealed, as was assumed, that FEA simulation is capable of accurately simulating curb impacts as long as the vehicle model used has the correct modeling features incorporated into it. Selected simulation results are shown in figure 23. Figures 23 (a) and (b) show results for a head-on impact (90 degree impact angle) on a 6” curb face. Figures 23 (c) through (f) show a head on impact on a sloped curb. The figures, and the results obtained, indicated that the model was capable of properly predicting the dynamic behavior of the bogie after the impact.

The LLNL bogie model, however, is a bogie model, not a model of an actual vehicle. Therefore, it cannot be directly used to simulate passenger vehicle response to curb impacts. However, the combination of the simulation results from the bogie model and the simulation results from the older NCAC truck model indicate that the newer NCAC truck model should be a very appropriate model for studying curb and berm impacts using FEA simulation.

11. CONCLUSION

During this study, the tasks listed below (along with many other secondary tasks not listed) were completed.

1. An extensive literature review of numerous vehicle impact simulation techniques was produced.
2. Vehicle impact trajectory plots, based on HVOSM modeling, were generated for a wide range of vehicle types, curb and berm types, impact speeds, and impact angles.
3. Previous studies in which HVOSM simulation results were accompanied by full-scale crash testing were reviewed to determine the validity and limitations of HVOSM for curb impact simulation.
4. The applicability of using the LS-DYNA3D FEA simulation code and publicly available FEA vehicle models for curb and berm impact was determined.
5. The advantages, disadvantages, features, and limitations of both HVOSM and FEA simulation techniques were identified and described.

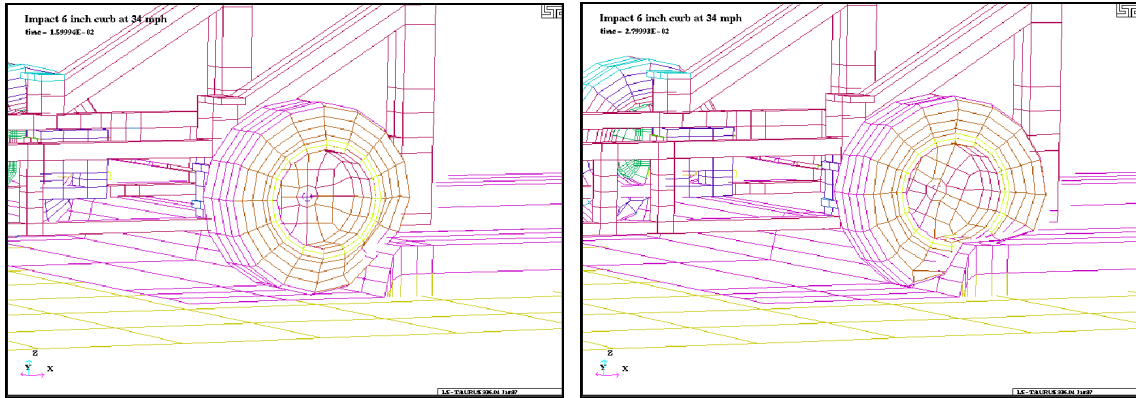

(a)

(b)

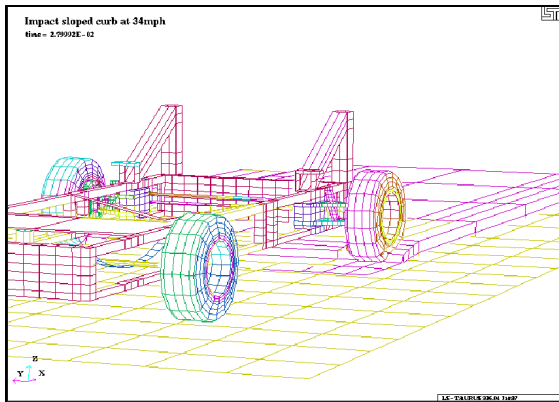

(c)

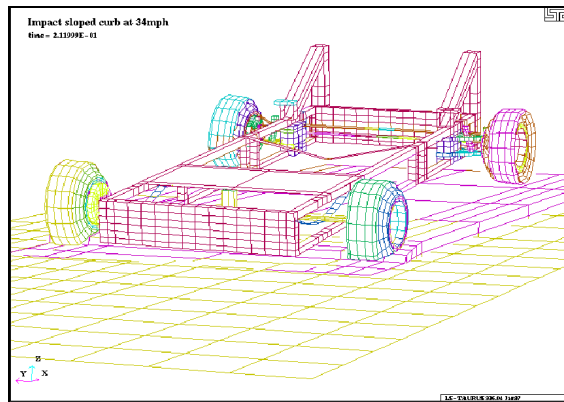

(d)

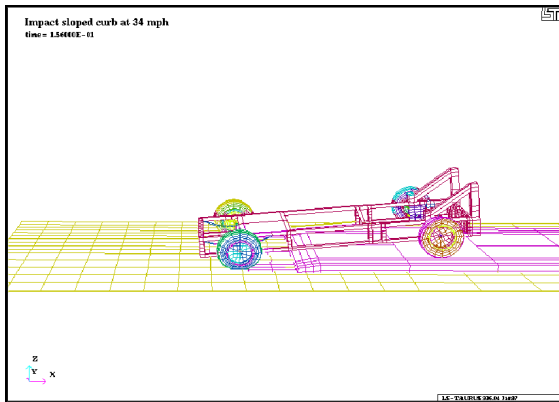

(e)

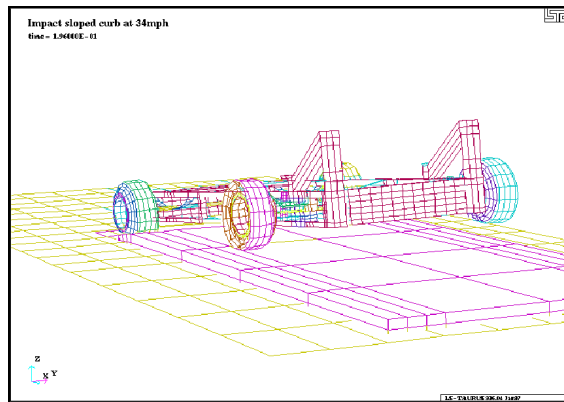

(f)

Figure 23. LLNL Bogie Model FEA Simulation Results

Based on the results of this study, it was found that HVOSM simulation results generated herein are reasonably accurate as long as the limitations of the modeling methods employed are not violated. Moderate velocity impacts on shallow curbs and rigid berms can generally be simulated using HVOSM with confidence. Higher speed impacts, impacts on large curbs, interaction of tires with berm soil, and interaction of the vehicle with guide rails cannot be accomplished using HVOSM but can be accomplished by using appropriate FEA simulation methods. However, continuing validation, through the use of full scale crash testing, is also needed for FEA vehicle models.

REFERENCES

- AASHTO (1977), *Guide for Selecting, Locating, and Designing Traffic Barriers*, American Association of State Highway and Transportation Officials, Washington, D.C., 1977.
- AASHTO (1996), *Roadside Design Guide*, American Association of State Highway and Transportation Officials, Washington, D.C., January 1996.
- Allen, R.W., Szostak, H.T., Klyde, D.H., Rosenthal, T.J., Owens, k.J. (1992), *Vehicle Dynamic Stability and Rollover*, Report No. DOT HS 807 956 (also STI Report No. STI-TR-1268-1), Systems Technology, Inc., June 1992.
- Bohn, P.F., Keenan, R.J. (1978), *Improved hybrid Computer Vehicle Handling Program*, Report No. DOT-HS-805-031, National Highway Traffic Safety Administration, Oct. 1978.
- Council, F.M., Reinfurt, D.W., Knoblauch, R.N., Stewart, J.R., McHenry, B.G. (1988), *Safe Geometric Design for Minicars*, Report No. FHWA-RD-87/047, Highway Safety Research Center, , Dec. 1988.
- DeLeys, N.J., Segal. D.J., (1973), *Vehicle Redirection Effectiveness of Median Berms and Curbs*, Report No. HF-5095-V-2, Calspan Corporation, May 1973.
- Heydinger, G.J. (1980), *Improved Simulation and Validation of Road Vehicle Handling Dynamics*, Ph.D. Dissertation, The Ohio State University, 1980.
- Holloway, J.C., Sicking, D.L., Rosson, B.T. (1994), *Performance Evaluation of NDOR Mountable Curbs*, Research Report No. TRP-03-37-94, Midwest Roadside Safety Facility (MwRSF), Center for Infrastructure Research, Department of Civil Engineering, University of Nebraska-Lincoln, June 1994.
- Gillespie, T.D. (1992), *Fundamentals of Vehicle Dynamics*, Society of Automotive Engineers, Warrendale, PA.
- LSTC (1997), *LS-DYANA User's Manual*, Livermore Software Technology Corporations, Livermore California, 1997.
- NCHRP-150 (1974), *Effect of Curb Geometry and Location on Vehicle Behavior*, Report No. 150, National Cooperative Highway Research Program, Transportation Research Board, 1974.
- NCHRP-153 (1974), *Recommended Procedures for Vehicle Crash Testing of Highway Appurtenances*, Report No. 153, National Cooperative Highway Research Program, Transportation Research Board, 1974.

- NCHRP-230 (1980), *Recommended Procedures for the Safety Performance Evaluation of Highway Safety Appurtenances*, Report No. 230, National Cooperative Highway Research Program, Transportation Research Board, 1980.
- NCHRP-244 (1997), *Guardrail and Median Barrier Crashworthiness*, Synthesis No. 244, National Cooperative Highway Research Program, Transportation Research Board, 1997.
- NCHRP-350 (1993), *Recommended Procedures for the Safety Performance Evaluation of Highway Features*, Report No. 350, National Cooperative Highway Research Program, Transportation Research Board, 1993.
- Perera, H.S. (1987), *Simulation of Vehicular Impacts with Safety-Shaped Barrier*, Ph.D. Dissertation, Texas A&M University, 1987.
- Powell, G.H. (1973), *Barrier VII: A Computer Program for Evaluation of Automobile Barrier Systems*, Department of Transportation, Federal Highway Administration, Report FHWA-RD-73-51, April, 1973.
- Ross, H.E. Jr., Krammes, R.A., Sicking D.L., Tyler, K.D., Perera, H.S. (1983), *Traffic Barriers and Control Treatments for Restricted Work Zones, Volume III – Appendices C and D*, NCHRP Project 17-8, Texas Transportation Institute, Texas A&M University, May 1983.
- Ross, H.E., Sicking, D.L. (1986), *Roadside Safety Design for Small Vehicles*, Texas Transportation Institute, May 1986.
- Schuring, D.J., Kunkel, D.T., Massing, D.E., Roland, R.D. (1974), *The Influence of Tire Properties on Passenger Vehicle Handling*, Report No. ZM-5350-K-3, Vol.3-Appendices, Calspan Corporation, Jun. 1974.
- Segal, D.J. (1976), *Highway-Vehicle-Object Simulation Model*, Report No. FHWA-RD-76-162, Feb. 1976.
- Segal, D.J., Ranney, T.A. (1978), *Evaluation of Horizontal Curve Design*, Report No. FHWA-RD-79-48, Calspan Corporation, Oct. 1978.

APPENDIX A –VEHICLE PARAMETER DATA BLOCKS FOR HVOSM

This appendix contains the HVOSM input file data blocks that describe the vehicle (and tire) parameters for the following vehicles.

1. Ford Escort (2 door small car, 1989)
2. Honda Civic (4 door small car, 1989)
3. Chevrolet Cavalier (4 door mid-size car, 1980's)
4. Chevrolet Pick-up (1980's)
5. Plymouth Voyager (van, 1980's)
6. Jeep Wrangler (sport-utility vehicle, 1980's)

Each of these vehicles was simulated impacting the five curb and four berm profiles considered in this study at various impact angles and impact speeds. Note that the initial condition lines in each of these vehicle data blocks are only template lines. The appropriate impact angles and impact speeds were inserted into the template fields (designated “xxxxxxx” and “zzzzzzz” in the HVOSM data blocks) for each of the cases in the overall parametric study.

```

*****
* FORD ESCORT INPUT DATA
* WITH MINIMUM OMEGA FRONT : -1.5
*****
SAMPLE CURB TEST TYPE C                                0100
0.0      5.0      0.005  0.005  70.0   0.0   0.0                                0101
1.0      1.0      6.0    0.001                                0102
1.0                                           0103
      1.0      1.0      1.0                                0104
1989 Escort(2 dr)                                       0200
6.25     0.375   0.375   2160.0  11880.0 13620.0 0.0                                0201
34.8     59.4   54.72   56.04  -10.8                                0202
125.0    150.0  300.0   150.0   300.0  0.5   -1.5   3.0                                0204
125.0    150.0  300.0   150.0   300.0  0.5   -1.5   3.0                                0205
8.3333   10.0   0.001   8.3333  10.00  0.001                                0206
114000.0 0.0     0.0     0.0     0.0036 0.0012 0.0                                0207
500.0    600.0  0.4     5000.0  0.075  1.5                                0208
-5.0     5.0     1.0                                           0209
-0.95    -0.76  -0.57   -0.38  -0.19  0.0   0.19   0.38   0.57                                1209
0.76     0.95                                           2209
-0.32    -0.256 -0.192  -0.128 -0.064 0.0   0.064  0.128  0.192                                3209
0.256    0.32                                           4209
-5.0     5.0     0.5                                           0210
0.1000   0.1000 0.1000  0.1000 0.1000 0.1000 0.1000 0.1000 0.1000                                1210
0.1000   0.1000 0.1000  0.1000 0.1000 0.1000 0.1000 0.1000 0.1000                                2210
0.1000   0.1000 0.1000                                3210
-5.0     5.0     5.0                                           0211
0.090    0.090  0.090                                1211
P165/80R13 TIRE INFORMATION                               0300
1.0      1.0      1.0      1.0      5.30   0.2650                                0301
1083.33  4.24    10.0    1.0     15.66  2350.0 0.53   -24450. 1.00                                1301
0.92                                           13.0                                0302
FORD ESCORT INITIAL IMPACT ANGLE AND SPEED              0600
0.0      0.0      xxxxxxxx 0.0   0.0   0.0   0.0   0.0                                0601
0.0      -217.25 -23.40 zzzzzzzz                                0602
                                           09999

```

```

#NOTE : xxxxxxxx ON DATA CARD 601 REPRESENTS THE INITIAL VEHICLE IMPACT ANGLE
#       (YAW ANGLE). THE UNIT IS DEGREE.
#NOTE : zzzzzzzz ON DATA CARD 602 REPRESENTS THE INITIAL VEHICLE IMPACT SPEED.
#       THE UNIT IS IN/SEC.

```

```

*****

```

```

*****
* FORD ESCORT INPUT DATA
* WITH MAXIMUM OMEGA FRONT : -3.5
*****
SAMPLE CURB TEST TYPE C                                0100
0.0      5.0      0.005  0.005  70.0    0.0    0.0                                0101
1.0      1.0      6.0    0.001                                0102
1.0                                           0103
      1.0      1.0    1.0                                0104
1989 Escort(2 dr)                                       0200
6.25     0.375   0.375   2160.0  11880.0 13620.0 0.0                                0201
34.8     59.4   54.72   56.04   -10.8                                0202
125.0    150.0  300.0   150.0   300.0   0.5    -3.5    5.0                                0204
125.0    150.0  300.0   150.0   300.0   0.5    -3.5    5.0                                0205
8.3333   10.0   0.001   8.3333  10.00   0.001                                0206
114000.0 0.0     0.0     0.0     0.0036 0.0012 0.0                                0207
500.0    600.0   0.4     5000.0  0.075   1.5                                0208
-5.0     5.0     1.0                                           0209
-0.95    -0.76   -0.57   -0.38   -0.19   0.0    0.19   0.38   0.57                                1209
0.76     0.95                                           2209
-0.32    -0.256  -0.192  -0.128  -0.064  0.0    0.064  0.128  0.192                                3209
0.256    0.32                                           4209
-5.0     5.0     0.5                                           0210
0.1000   0.1000  0.1000  0.1000  0.1000  0.1000 0.1000 0.1000 0.1000                                1210
0.1000   0.1000  0.1000  0.1000  0.1000  0.1000 0.1000 0.1000 0.1000                                2210
0.1000   0.1000  0.1000                                           3210
-5.0     5.0     5.0                                           0211
0.090    0.090  0.090                                           1211
P165/80R13 TIRE INFORMATION                               0300
1.0      1.0      1.0      1.0      5.30    0.2650                                0301
1083.33  4.24    10.0     1.0     15.66   2350.0 0.53    -24450. 1.00                                1301
0.92                                           13.0                                0302
FORD ESCORT INITIAL IMPACT ANGLE AND SPEED              0600
0.0      0.0      xxxxxxxx 0.0    0.0    0.0    0.0                                0601
0.0      -217.25 -23.40  zzzzzzzz                                0602
                                           09999

```

```

#NOTE : xxxxxxxx ON DATA CARD 601 REPRESENTS THE INITIAL VEHICLE IMPACT ANGLE
#       (YAW ANGLE). THE UNIT IS DEGREE.
#NOTE : zzzzzzzz ON DATA CARD 602 REPRESENTS THE INITIAL VEHICLE IMPACT SPEED.
#       THE UNIT IS IN/SEC.

```

```
*****
```

```

*****
* CIVIC(4 DOOR) INPUT DATA
* WITH MINIMUM OMEGA FRONT : -1.5
*****
SAMPLE CURB TEST TYPE C                                0100
0.0      5.0      0.005  0.005  70.0   0.0   0.0                                0101
1.0      1.0      6.0    0.001                                0102
1.0                                            0103
      1.0      1.0      1.0                                0104
1982 Honda Civic(4 door)                                0200
5.0833   0.3333   0.3333  1740.0  8520.0  10440.0  0.0                                0201
34.44    56.52    53.16   54.0   -10.56                                0202
116.7    233.3    466.7   233.3   446.7   0.5   -1.50   3.00                                0204
145.8    233.3    466.7   233.3   466.7   0.5   -1.50   3.00                                0205
9.5833   10.0     0.001   9.5833  10.0   0.001                                0206
76800.0  0.0        0.0        0.0   -0.005  0.0   0.0                                0207
500.0    600.0    0.400   5000.  0.075  1.500                                0208
-5.0     5.0      1.0                                           0209
-0.75    -0.6     -0.45   -0.3   -0.15   0.0   0.15   0.3   0.45                                1209
0.6      0.75                                           2209
-0.875   -0.7     -0.525  -0.35  -0.175  0.0   0.175  0.35  0.525                                3209
0.7      0.875                                           4209
-5.0     5.0      0.5                                           0210
0.1000   0.1000  0.1000  0.1000  0.1000  0.1000  0.1000  0.1000  0.1000                                1210
0.1000   0.1000  0.1000  0.1000  0.1000  0.1000  0.1000  0.1000  0.1000                                2210
0.1000   0.1000  0.1000                                3210
-5.0     5.0      5.0                                           0211
0.090    0.090  0.090                                           1211
P175/80R13 TIRE INFOMATION                                0300
1.0      1.0      1.0      1.0      5.336  0.2668                                0301
1138.15  4.269    10.0     570.0   12.0   2880.0  0.618  15900.0  1.0000                                1301
0.85                                           13.39                                0302
1982 HONDA CIVIC (4 DOOR) INITIAL IMPACT ANGLE AND SPEED 0600
0.0      0.0      xxxxxxxx  0.0    0.0    0.0    0.0    0.0                                0601
0.0      -217.25  -21.36  zzzzzzzz                                0602
09999

```

```

#NOTE : xxxxxxxx ON DATA CARD 601 REPRESENTS THE INITIAL VEHICLE IMPACT ANGLE
#       (YAW ANGLE). THE UNIT IS DEGREE.
#NOTE : zzzzzzzz ON DATA CARD 602 REPRESENTS THE INITIAL VEHICLE IMPACT SPEED.
#       THE UNIT IS IN/SEC.

```

```

*****

```

```

*****
* CIVIC(4 DOOR) INPUT DATA
* WITH MAXIMUM OMEGA FRONT : -3.5
*****
SAMPLE CURB TEST TYPE C                                0100
0.0      5.0      0.005  0.005  70.0   0.0   0.0                                0101
1.0      1.0      6.0    0.001                                0102
1.0                                           0103
      1.0      1.0      1.0                                0104
1982 Honda Civic(4 door)                                0200
5.0833   0.3333   0.3333  1740.0  8520.0  10440.0  0.0                                0201
34.44    56.52   53.16   54.0   -10.56                                0202
116.7    233.3   466.7   233.3  446.7   0.5    -3.50   5.00                                0204
145.8    233.3   466.7   233.3  466.7   0.5    -3.50   5.00                                0205
9.5833   10.0     0.001   9.5833  10.0    0.001                                0206
76800.0  0.0        0.0      0.0    -0.005  0.0    0.0                                0207
500.0    600.0   0.400   5000.  0.075  1.500                                0208
-5.0     5.0      1.0                                           0209
-0.75    -0.6     -0.45   -0.3   -0.15  0.0    0.15   0.3    0.45                                1209
0.6      0.75                                           2209
-0.875   -0.7     -0.525  -0.35  -0.175  0.0    0.175  0.35   0.525                                3209
0.7      0.875                                           4209
-5.0     5.0      0.5                                           0210
0.1000   0.1000  0.1000  0.1000  0.1000  0.1000  0.1000  0.1000  0.1000                                1210
0.1000   0.1000  0.1000  0.1000  0.1000  0.1000  0.1000  0.1000  0.1000                                2210
0.1000   0.1000  0.1000                                           3210
-5.0     5.0      5.0                                           0211
0.090    0.090  0.090                                           1211
P175/80R13 TIRE INFOMATION                                0300
1.0      1.0      1.0      1.0      5.336  0.2668                                0301
1138.15  4.269   10.0     570.0  12.0   2880.0  0.618  15900.0  1.0000                                1301
0.85                                           13.39                                0302
1982 HONDA CIVIC (4 DOOR) INITIAL IMPACT ANGLE AND SPEED 0600
0.0      0.0      xxxxxxxx  0.0    0.0    0.0    0.0    0.0                                0601
0.0      -217.25 -21.36  zzzzzzzz                                0602
                                           09999

```

```

#NOTE : xxxxxxxx ON DATA CARD 601 REPRESENTS THE INITIAL VEHICLE IMPACT ANGLE
#       (YAW ANGLE). THE UNIT IS DEGREE.
#NOTE : zzzzzzzz ON DATA CARD 602 REPRESENTS THE INITIAL VEHICLE IMPACT SPEED.
#       THE UNIT IS IN/SEC.

```

```
*****
```

```

*****
* CHEVY CAVALIER INPUT DATA
* WITH MINIMUM OMEGA FRONT : -1.5
*****
SAMPLE CURB TEST                                0100
0.0      5.0      0.005    0.001    70.0     0.0     0.0                                0101
0.0      1.0      6.0      0.001                                0102
1.0                                             0103
      1.0      1.0      1.0                                0104
1985 Chev. Cavalier                              0200
5.77365  0.37709  0.37709  2005.0   14043.0  16413.0  0.0     290.0                                0201
32.9378  68.4022  55.92    55.44   -13.390  46.44                                0202
95.8333  191.667  383.333  191.667  383.333  0.5     -1.5    3.0                                0204
98.3333  191.667  383.333  191.667  383.333  0.5     -2.0    4.0                                0205
6.83256  10.0000  0.001    5.76327  10.0000  0.001                                0206
246285.0 84440.0  0.00                                0207
500.0    600.0    0.4      5000.0   0.075    1.5                                0208
-5.0     5.0      1.0                                             0209
-0.65    -0.52    -0.39    -0.26    -0.13    0.0     0.13    0.26    0.39                                1209
0.52     0.65                                             2209
-5.0     5.0      0.5                                             0210
0.1000   0.1000   0.1000   0.1000   0.1000   0.1000   0.1000   0.1000   0.1000                                1210
0.1000   0.1000   0.1000   0.1000   0.1000   0.1000   0.1000   0.1000   0.1000                                2210
0.1000   0.1000   0.1000                                3210
-5.0     5.0      5.0                                             0211
0.090    0.090    0.090                                             1211
P175/80R13 TIRE INFOMATION                       0300
1.0      1.0      1.0      1.0      5.336    0.2668                                0301
1138.15  4.269    10.0     570.0    12.0     2880.0   0.618    15900.0  1.0000                                1301
0.85                                             13.39                                0302
1985 Chev. Cavalier INITIAL IMPACT SPEED AND ANGLE 0600
0.0      0.0      xxxxxxxx  0.0     0.0     0.0     0.0     0.0                                0601
0.0      -217.25  -23.00  zzzzzzzz                                0602
09999

```

```

#NOTE : xxxxxxxx ON DATA CARD 601 REPRESENTS THE INITIAL VEHICLE IMPACT ANGLE
#       (YAW ANGLE). THE UNIT IS DEGREE.
#NOTE : zzzzzzzz ON DATA CARD 602 REPRESENTS THE INITIAL VEHICLE IMPACT SPEED.
#       THE UNIT IS IN/SEC.

```

```

*****

```

```

*****
* CHEVY CAVALIER INPUT DATA
* WITH MAXIMUM OMEGA FRONT : -2.0
*****
SAMPLE CURB TEST                                0100
0.0      5.0      0.005      0.001      70.0      0.0      0.0                                0101
0.0      1.0      6.0      0.001                                0102
1.0                                            0103
      1.0      1.0      1.0                                0104
1985 Chev. Cavalier                             0200
5.77365  0.37709  0.37709  2005.0  14043.0  16413.0  0.0      290.0          0201
32.9378  68.4022  55.92    55.44   -13.390  46.44          0202
95.8333  191.667  383.333  191.667  383.333  0.5      -2.0      4.0          0204
98.3333  191.667  383.333  191.667  383.333  0.5      -2.5      5.0          0205
6.83256  10.0000  0.001    5.76327  10.0000  0.001          0206
246285.0 84440.0  0.00    0207
500.0    600.0    0.4      5000.0  0.075    1.5          0208
-5.0     5.0     1.0          0209
-0.65    -0.52    -0.39    -0.26    -0.13    0.0      0.13     0.26     0.39    1209
0.52     0.65          2209
-5.0     5.0     0.5          0210
0.1000   0.1000   0.1000   0.1000   0.1000   0.1000   0.1000   0.1000   0.1000   1210
0.1000   0.1000   0.1000   0.1000   0.1000   0.1000   0.1000   0.1000   0.1000   2210
0.1000   0.1000   0.1000          3210
-5.0     5.0     5.0          0211
0.090    0.090    0.090          1211
P175/80R13 TIRE INFOMATION                     0300
1.0      1.0      1.0      1.0      5.336    0.2668          0301
1138.15  4.269    10.0     570.0    12.0     2880.0  0.618    15900.0  1.0000    1301
0.85          13.39          0302
1985 Chev. Cavalier INITIAL IMPACT SPEED AND ANGLE 0600
0.0      0.0      xxxxxxxx  0.0      0.0      0.0      0.0      0.0          0601
0.0      -217.25  -23.00  zzzzzzzz          0602
09999

```

```

#NOTE : xxxxxxxx ON DATA CARD 601 REPRESENTS THE INITIAL VEHICLE IMPACT ANGLE
#       (YAW ANGLE). THE UNIT IS DEGREE.
#NOTE : zzzzzzzz ON DATA CARD 602 REPRESENTS THE INITIAL VEHICLE IMPACT SPEED.
#       THE UNIT IS IN/SEC.

```

```

*****

```



```

*****
* PLYMOUTH VOYAGER VAN INPUT DATA
* WITH MINIMUM OMEGA FRONT : -1.5
*****
SAMPLE CURB TEST TYPE C                                0100
0.0      5.0      0.005  0.01   70.0   0.0   0.0                                0101
0.0      1.0      6.0    0.001                                0102
1.0                                           0103
      1.0      1.0    1.0                                0104
1989 Plym. Voyager                                0200
9.0833   0.5      0.5    4440.0  30480.0 36000.0 0.0    450.0                                0201
48.6     70.2     60.0    61.8   -0.72  45.8                                0202
154.17   291.67  583.34  291.67 583.34 0.50   -1.5   3.0                                0204
141.67   291.67  583.34  291.67 583.34 0.50   -1.5   3.0                                0205
12.3333  10.0     0.001   9.5833 10.0    0.001                                0206
214800.0 -34200.0 0.00    0.00                                0207
500.0    600.0   0.4     5000.0 0.075  1.5                                0208
-5.0     5.0     1.0                                           0209
-0.55    -0.44  -0.33   -0.22  -0.11  0.0    0.11   0.22   0.33                                1209
0.44     0.55                                           2209
-5.0     5.0     0.5                                           0210
0.1000   0.1000 0.1000  0.1000 0.1000 0.1000 0.1000 0.1000 0.1000                                1210
0.1000   0.1000 0.1000  0.1000 0.1000 0.1000 0.1000 0.1000 0.1000                                2210
0.1000   0.1000 0.1000                                3210
-5.0     5.0     5.0                                           0211
0.090    0.090  0.090                                1211
P195/75R14 TIRE INFORMATION                                0300
1.0      1.0      1.0      1.0     5.880  0.29400                                0301
1166.67  4.7040  10.0    516.0   16.7   3600.0 0.368  -11300. 1.0                                1301
0.92                                           14.677                                0302
1989 VOYAGER IMPACT ANGLE AND SPEED                                0600
0.0      0.0      xxxxxxxx 0.0    0.0    0.0    0.0    0.0                                0601
0.0      -217.25 -28.44  zzzzzzzz                                0602
09999

```

```

#NOTE : xxxxxxxx ON DATA CARD 601 REPRESENTS THE INITIAL VEHICLE IMPACT ANGLE
#       (YAW ANGLE). THE UNIT IS DEGREE.
#NOTE : zzzzzzzz ON DATA CARD 602 REPRESENTS THE INITIAL VEHICLE IMPACT SPEED.
#       THE UNIT IS IN/SEC.

```

```

*****

```

```

*****
* PLYMOUTH VOYAGER VAN INPUT DATA
* WITH MAXIMUM OMEGA FRONT : -3.5
*****
SAMPLE CURB TEST TYPE C                                0100
0.0      5.0      0.005  0.01   70.0   0.0   0.0                                0101
0.0      1.0      6.0    0.001                                0102
1.0                                           0103
      1.0      1.0      1.0                                0104
1989 Plym. Voyager                                    0200
9.0833   0.5      0.5    4440.0  30480.0 36000.0 0.0    450.0                                0201
48.6     70.2     60.0    61.8   -0.72  45.8                                0202
154.17   291.67  583.34  291.67 583.34 0.50   -3.5   5.0                                0204
141.67   291.67  583.34  291.67 583.34 0.50   -3.5   5.0                                0205
12.3333  10.0      0.001   9.5833 10.0    0.001                                0206
214800.0 -34200.0 0.00     0.00                                0207
500.0    600.0   0.4     5000.0 0.075   1.5                                0208
-5.0     5.0     1.0                                           0209
-0.55    -0.44  -0.33   -0.22  -0.11  0.0    0.11   0.22   0.33                                1209
0.44     0.55                                           2209
-5.0     5.0     0.5                                           0210
0.1000   0.1000 0.1000 0.1000 0.1000 0.1000 0.1000 0.1000 0.1000                                1210
0.1000   0.1000 0.1000 0.1000 0.1000 0.1000 0.1000 0.1000 0.1000                                2210
0.1000   0.1000 0.1000                                3210
-5.0     5.0     5.0                                           0211
0.090    0.090 0.090                                           1211
P195/75R14 TIRE INFORMATION                                0300
1.0      1.0      1.0      1.0    5.880  0.29400                                0301
1166.67  4.7040  10.0    516.0  16.7   3600.0 0.368  -11300. 1.0                                1301
0.92                                           14.677                                0302
1989 VOYAGER IMPACT ANGLE AND SPEED                                0600
0.0      0.0      xxxxxxxx 0.0    0.0    0.0    0.0    0.0                                0601
0.0      -217.25 -28.44 zzzzzzzz                                0602
09999

```

```

#NOTE : xxxxxxxx ON DATA CARD 601 REPRESENTS THE INITIAL VEHICLE IMPACT ANGLE
#       (YAW ANGLE). THE UNIT IS DEGREE.
#NOTE : zzzzzzzz ON DATA CARD 602 REPRESENTS THE INITIAL VEHICLE IMPACT SPEED.
#       THE UNIT IS IN/SEC.

```

```

*****

```

```

*****
* WRANGLER INPUT DATA
* WITH MINIMUM OMEGA FRONT : -1.5
*****
SAMPLE CURB TEST                                0100
0.0      5.0      0.005    0.01    70.0    0.0    0.0                                0101
2.0      1.0      6.0      0.001                                0102
1.0                                             0103
      1.0      1.0      1.0                                0104
1989 Wrangler(2dr)                              0200
6.89773  0.6569  0.6569  2844.0  13255.3  16575.8  0.0      381.114  380.326  0201
42.9774  50.7186  57.96   58.02   5.484   47.02   1.884   46.96                                0202
208.33   416.67  833.33  416.67  833.33  0.5     -1.5    3.0                                0204
218.33   416.67  833.33  416.67  833.33  0.50    -1.5    3.0                                0205
13.8051  10.0     0.001   14.8678  10.0    0.001                                0206
204754.1 20787.1  0.00    0.00                                0207
500.0    600.0    0.4     5000.0  0.075   1.5                                0208
-5.0     5.0     0.5                                0210
0.1000   0.1000  0.1000  0.1000  0.1000  0.1000  0.1000  0.1000  0.1000  1210
0.1000   0.1000  0.1000  0.1000  0.1000  0.1000  0.1000  0.1000  0.1000  2210
0.1000   0.1000  0.1000                                3210
-5.0     5.0     5.0                                0211
0.090    0.090  0.090                                1211
P215/75R15 TIRE INFORMATION                    0300
1.0      1.0      1.0      1.0      6.6160  0.22814                                0301
1162.8   5.2928  10.0    7780.0  4.56    3680.0  0.48    -6720.0  1.0     1301
0.85                                           15.9646                                0302
WRANGLER INITIAL IMPACT ANGLE AND SPEED      0600
0.0      0.0      xxxxxxxx  0.0    0.0    0.0    0.0                                0601
0.0      -217.25 -25.52  zzzzzzzz                                0602
                                             09999

```

```

#NOTE : xxxxxxxx ON DATA CARD 601 REPRESENTS THE INITIAL VEHICLE IMPACT ANGLE
#       (YAW ANGLE). THE UNIT IS DEGREE.
#NOTE : zzzzzzzz ON DATA CARD 602 REPRESENTS THE INITIAL VEHICLE IMPACT SPEED.
#       THE UNIT IS IN/SEC.

```

```

*****

```

```

*****
* WRANGLER INPUT DATA
* WITH MAXIMUM OMEGA FRONT : -3.5
*****
SAMPLE CURB TEST                                0100
0.0      5.0      0.005    0.01    70.0    0.0    0.0                                0101
2.0      1.0      6.0      0.001                                0102
1.0                                             0103
      1.0      1.0      1.0                                0104
1989 Wrangler(2dr)                              0200
6.89773  0.6569  0.6569  2844.0  13255.3  16575.8  0.0      381.114  380.326  0201
42.9774  50.7186  57.96   58.02   5.484   47.02   1.884   46.96                                0202
208.33   416.67  833.33  416.67  833.33  0.5     -3.5    5.0                                0204
218.33   416.67  833.33  416.67  833.33  0.50    -3.5    5.0                                0205
13.8051  10.0      0.001   14.8678  10.0    0.001                                0206
204754.1 20787.1  0.00    0207
500.0    600.0    0.4     5000.0  0.075  1.5                                0208
-5.0     5.0      0.5                                0210
0.1000   0.1000  0.1000  0.1000  0.1000  0.1000  0.1000  0.1000  0.1000  1210
0.1000   0.1000  0.1000  0.1000  0.1000  0.1000  0.1000  0.1000  0.1000  2210
0.1000   0.1000  0.1000                                3210
-5.0     5.0      5.0                                0211
0.090    0.090  0.090                                1211
P215/75R15 TIRE INFORMATION                    0300
1.0      1.0      1.0      1.0      6.6160  0.22814                                0301
1162.8   5.2928  10.0    7780.0  4.56   3680.0  0.48    -6720.0  1.0      1301
0.85                                           15.9646                                0302
WRANGLER INITIAL IMPACT ANGLE AND SPEED      0600
0.0      0.0      xxxxxxxx  0.0    0.0    0.0    0.0                                0601
0.0      -217.25 -25.52  zzzzzzzz                                0602
09999

```

```

#NOTE : xxxxxxxx ON DATA CARD 601 REPRESENTS THE INITIAL VEHICLE IMPACT ANGLE
#       (YAW ANGLE). THE UNIT IS DEGREE.
#NOTE : zzzzzzzz ON DATA CARD 602 REPRESENTS THE INITIAL VEHICLE IMPACT SPEED.
#       THE UNIT IS IN/SEC.

```

```

*****

```

APPENDIX B –CURB AND BERM PARAMETER BLOCKS FOR HVOSM

This appendix contains the HVOSM input file data blocks that describe the curb and berm profiles studied. These include the following.

- 10.2” Curb
- 11.4” Curb
- 12.6” Curb
- 13.8” Curb
- 14.Sloped Curb
- 15.Berm 6-to-1 slope, 4” rise
- 16.Berm 6-to-1 slope, 6” rise
- 17.Berm 6-to-1 slope, 12” rise
- 18.Berm 10-to-1 slope, 3.6” rise

The dimensions used in modeling these curb and berm profiles are given on the following pages.

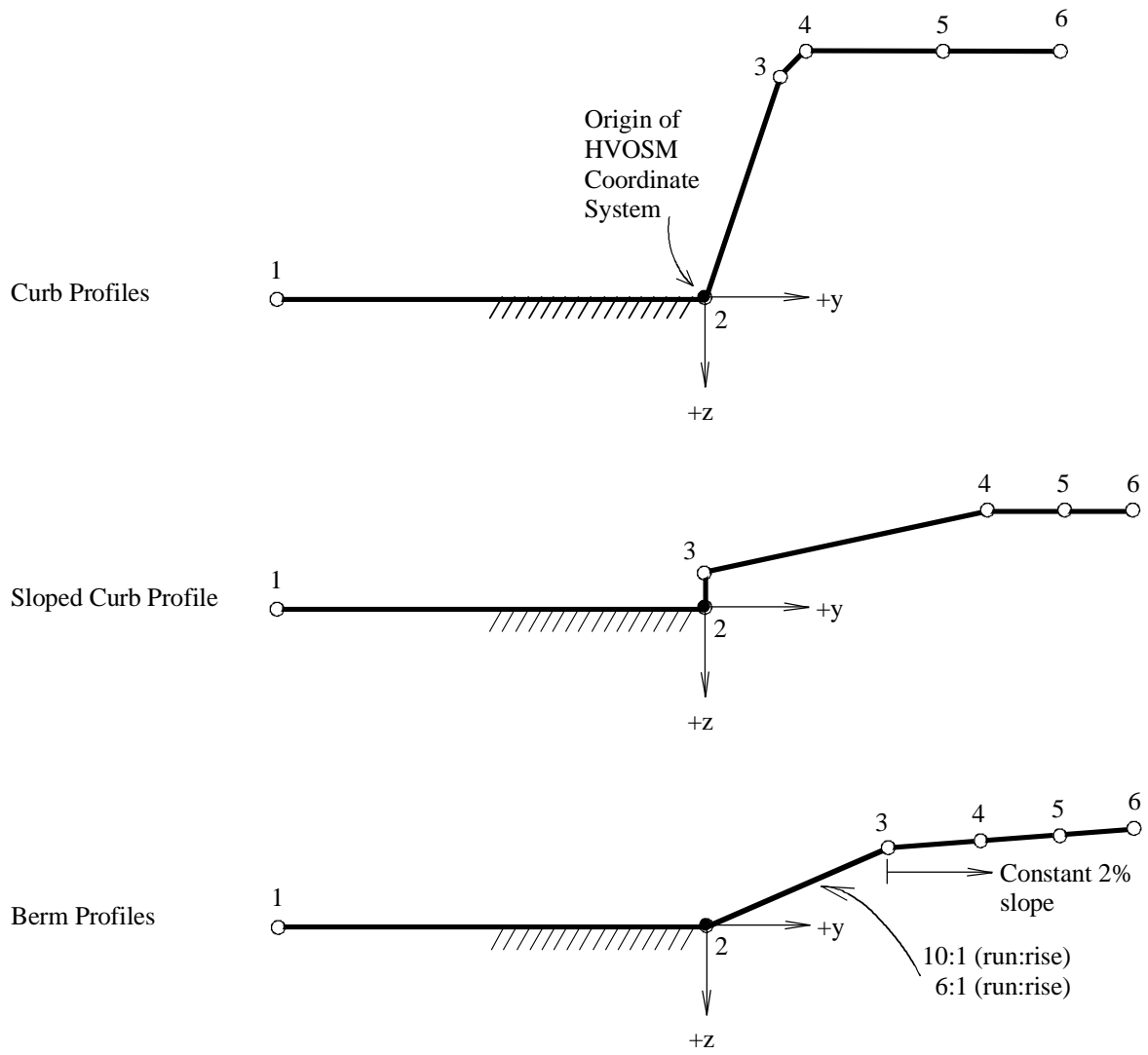

Curb and Berm Profiles Modeled for Vehicle Impact Simulations
(Dimensions are given on next page)

Curb Profiles:

Curb Name	Y1	Z1	Y2	Z2	Y3	Z3	Y4	Z4	Y5	Z5	Y6	Z6
2"	-17.25	0	0	0	1	-1	2	-2	3 [†]	-2	4 [†]	-2
4"	-17.25	0	0	0	1	-3	2	-4	3 [†]	-4	4 [†]	-4
6"	-17.25	0	0	0	1	-5	2	-6	3 [†]	-6	4 [†]	-6
8"	-17.25	0	0	0	1	-7	2	-8	3 [†]	-8	4 [†]	-8
<i>Sloped</i>	-17.25	0	0	0	0	-2	12	-4	13 [†]	-4	14 [†]	-4

[†] These dimensions are arbitrary. Each profile is extended horizontally (with zero slope and at constant z-elevation) to infinity in the y-direction from the position of the last point in the profile (i.e. point number 6).

Berm Profiles:

Berm Name	Y1	Z1	Y2	Z2	Y3	Z3	Y4	Z4	Y5	Z5	Y6	Z6
<i>6to1 : 4"</i>	-17.25	0	0	0	24	-4	34 [‡]	-4.2	44 [‡]	-4.4	54 [‡]	-4.6
<i>6to1 : 6"</i>	-17.25	0	0	0	36	-6	46 [‡]	-6.2	56 [‡]	-6.4	66 [‡]	-6.6
<i>6to1 : 12"</i>	-17.25	0	0	0	72	-12	82 [‡]	-12.2	92 [‡]	-12.4	102 [‡]	-12.6
<i>10to1 : 3.6"</i>	-17.25	0	0	0	36	-3.6	46 [‡]	-3.8	56 [‡]	-4.0	66 [‡]	-4.2

[‡] These dimensions are based on arbitrary 10" increments in the horizontal direction and corresponding 0.2" increments in the vertical direction (i.e. 2% slope) starting at the top of the berm face. This arbitrary choice has no effect on the predicted trajectories. Each profile is extended horizontally at a constant slope of 2% to infinity in the y-direction from the position of the last point in the profile.

```

*****
*
* GEOMETRIC INPUT DATA FOR CURBS
*
*****

```

```

*****
* 2 INCH CURB
*****
2-INCH CURB INFO
-17.25  0.0    1.0    2.0    3.0    4.0    0.5    0500
0.0     -1.0   -2.0   -2.0   -2.0   0.0    0.0    0507
0.0     -45.0  -45.0  0.0   0.0   0.0    0.0    0508
0.0     -45.0  -45.0  0.0   0.0   0.0    0.0    0509

```

```

*****
* 4 INCH CURB
*****
4-INCH CURB INFO
-17.25  0.0    1.0    2.0    3.0    4.0    0.5    0500
0.0     -3.0   -4.0   -4.0   -4.0   0.0    0.0    0507
0.0     -71.56 -45.0  0.0   0.0   0.0    0.0    0508
0.0     -71.56 -45.0  0.0   0.0   0.0    0.0    0509

```

```

*****
* 6 INCH CURB
*****
6-INCH CURB INFO
-17.25  0.0    1.0    2.0    3.0    4.0    0.5    0500
0.0     -5.0   -6.0   -6.0   -6.0   0.0    0.0    0507
0.0     -78.69 -45.0  0.0   0.0   0.0    0.0    0508
0.0     -78.69 -45.0  0.0   0.0   0.0    0.0    0509

```

```

*****
* 8 INCH CURB
*****
8-INCH CURB INFO
-17.25  0.0    1.0    2.0    3.0    4.0    0.5    0500
0.0     -7.0   -8.0   -8.0   -8.0   0.0    0.0    0507
0.0     -81.87 -45.0  0.0   0.0   0.0    0.0    0508
0.0     -81.87 -45.0  0.0   0.0   0.0    0.0    0509

```

```

*****
* SLOPING CURB
*****
SLOPING-CURB INFO
-17.25  0.0    0.0    12.0   13.0   14.0   0.5    0500
0.0     -2.0   -4.0   -4.0   -4.0   0.0    0.0    0507
0.0     -90.0  -9.4623 0.0   0.0   0.0    0.0    0508
0.0     -90.0  -9.4623 0.0   0.0   0.0    0.0    0509

```

```

*****
*
* GEOMETRIC INPUT DATA FOR BERMS
*
*****

*****
* BERM 6:1 SLOPE WITH 4" RISE
*****
Berm section 6:1 slope with 4" total rise                                0500
-17.25  0.0    24.0   34.0   44.0   54.0   0.5                                0507
0.0     -4.0   -4.2   -4.4   -4.6                                     0508
0.0     -9.4623 -1.1458 -1.1458 -1.1458 -1.1458 0509

*****
* BERM 6:1 SLOPE WITH 6" RISE
*****
Berm section 6:1 slope with 6" total rise                                0500
-17.25  0.0    36.0   46.0   56.0   66.0   0.5                                0507
0.0     -6.0   -6.2   -6.4   -6.6                                     0508
0.0     -9.4623 -1.1458 -1.1458 -1.1458 -1.1458 0509

*****
* BERM 6:1 SLOPE WITH 12" RISE
*****
Berm section 6:1 slope with 12" total rise                               0500
-17.25  0.0    72.0   82.0   92.0  102.0   0.5                                0507
0.0     -12.0  -12.2  -12.4  -12.6                                     0508
0.0     -9.4623 -1.1458 -1.1458 -1.1458 -1.1458 0509

*****
* BERM 10:1 SLOPE WITH 3.6" RISE
*****
Berm section 10:1 slope with 3.6" total rise                             0500
-17.25  0.0    36.0   46.0   56.0   66.0   0.5                                0507
0.0     -3.6   -3.8   -4.0   -4.2                                     0508
0.0     -5.7106 -1.1458 -1.1458 -1.1458 -1.1458 0509

```