

Implementation of Advanced Fiber Optic and Piezoelectric Sensors

Fabrication and Laboratory Testing of Piezoelectric Ceramic- Polymer Composite Sensors for Weigh-in-Motion Systems

FINAL REPORT
February 1999

Submitted by

Mr. Patrick J. Szary *
Researcher and Associate Director

Dr. Ali Maher *
Professor and Chairman

Dr. Raj K. Panda **
Researcher

Dr. Ahmad Safari **
Professor and Chairman

*Center for Advanced Infrastructure & Transportation (CAIT)
Civil & Environmental Engineering
Rutgers, The State University
Piscataway, NJ 08854-8014

**Department of Ceramic and Material Engineering
Rutgers, The State University
Piscataway, NJ 08854-8014



NJDOT Research Project Manager
Mr. Anthony Chmiel

In cooperation with

New Jersey
Department of Transportation
Division of Research and Technology
and
U.S. Department of Transportation
Federal Highway Administration

Disclaimer Statement

"The contents of this report reflect the views of the author(s) who is (are) responsible for the facts and the accuracy of the data presented herein. The contents do not necessarily reflect the official views or policies of the New Jersey Department of Transportation or the Federal Highway Administration. This report does not constitute a standard, specification, or regulation."

The contents of this report reflect the views of the authors, who are responsible for the facts and the accuracy of the information presented herein. This document is disseminated under the sponsorship of the Department of Transportation, University Transportation Centers Program, in the interest of information exchange. The U.S. Government assumes no liability for the contents or use thereof.

1. Report No. FHWA 1999 – 029		2. Government Accession No.		3. Recipient's Catalog No.	
4. Title and Subtitle Implementation of Advanced Fiber Optic and Piezoelectric Sensors Fabrication and Laboratory Testing of Piezoelectric Ceramic-Polymer Composite Sensors for Weigh-in-Motion Systems				5. Report Date February 1999	
7. Author(s) Mr. Patrick J. Szary, Dr. Ali Maher, Dr. Raj K. Panda, and Dr. Ahmad Safari				6. Performing Organization Code CAIT/Rutgers/UTRC	
9. Performing Organization Name and Address New Jersey Department of Transportation CN 600 Trenton, NJ 08625				8. Performing Organization Report No. FHWA 1999 - 029	
12. Sponsoring Agency Name and Address Federal Highway Administration U.S. Department of Transportation Washington, D.C.				10. Work Unit No.	
15. Supplementary Notes				11. Contract or Grant No.	
16. Abstract <p>Weigh-in-motion (WIM) systems might soon replace the conventional techniques used to enforce weight restrictions for large vehicles on highways. Currently WIM systems use a piezoelectric polymer sensor that produces a voltage proportional to an applied pressure or load. Using this phenomenon, these systems are already being tested for collecting traffic data, including weigh-in-motion, measuring vehicle speeds, classifying vehicles by category and counting axles etc. The polymer sensors are usually in the form of a long tape or cable embedded within a long block of elastomeric material. These blocks are installed into grooves, which are cut into roads perpendicular to the traffic flow. The biggest disadvantage of the present sensor technology is that the piezoelectric output is not uniform with temperature and time, thus leading to large uncertainty in the data collected. On the other hand, piezoelectric ceramic materials have a much more stable response over a large temperature range. However, they are not used for traffic data sensors because of their inherent brittleness. Piezoelectric ceramic/polymer composites are made with an active piezoelectric ceramic embedded in a flexible non-active epoxy polymer. They hold a lot of promise for WIM applications because of their flexibility and excellent piezoelectric properties similar to that observed in bulk ceramics. In this research project, ceramic/polymer composite strips have been fabricated for use as piezoelectric sensors for measuring large loads. After encapsulating the polymer and composite sensors in elastomeric blocks in aluminum channels, the voltage outputs for different loads, loading rates and temperature conditions have been determined. Also, the composite and polymer sensor assemblies are being installed on a test road in order to perform actual measurements.</p>				13. Type of Report and Period Covered Final Report 10/1/1996 - 9/30/1998	
17. Key Words Piezoelectric, sensors, weigh-in-motion (WIM), composites				14. Sponsoring Agency Code	
18. Distribution Statement				15. Supplementary Notes	
19. Security Classif. (of this report) Unclassified		20. Security Classif. (of this page) Unclassified		21. No of Pages 31	22. Price

Acknowledgements

The authors wish to express their appreciation to the New Jersey Department of Transportation for the allotment of funds making this research possible. Special thanks are extended to Mr. Nicholas Vitillo and Anthony Chmiel of NJDOT for their support and extending the opportunity to participate in such a significant and extensive research program. The authors would also like to thank the Office of Naval Research (ONR), Center for Ceramic Research, University Transportation Research Center Region 2 (UTRC) and the Center for Advanced Infrastructure & Transportation (CAIT) at Rutgers University for providing financial support. The authors are also grateful to Dr. H. Nassif, Dr. N. Gucunski, N. Spratford, and E. Vogelius for help in processing the sensors.

TABLE OF CONTENTS

ABSTRACT	1
INTRODUCTION	1
CONVENTIONAL WEIGHING TECHNIQUES	1
WEIGH-IN-MOTION SYSTEMS.....	2
PRINCIPLE OF PIEZOELECTRICITY.....	3
PIEZOELECTRIC MATERIALS	4
EXPERIMENTAL	5
SENSOR FABRICATION.....	5
EMBEDMENT OF SENSOR.....	6
LOADING TESTS	7
RESULTS AND DISCUSSION	8
PIEZOELECTRIC SENSOR.....	8
LOADING RESULTS.....	9
CONCLUSIONS AND FUTURE WORK	12
REFERENCES	13
DESCRIPTION OF FIGURES	14

FIGURES.....	15
Figure 1: Schematic of the process for making the embedded piezoelectric ceramic-polymer composite sensor.	15
Figure 2: Photograph showing the setup of the MTS machine with an environmental control chamber.	16
Figure 3: (a) Schematic of a top view of a rod composite with square rods showing cracking in the epoxy ceramic interface.....	17
Figure 3: (b) schematic of top view of rod composite with circular rods.	17
Figure 3: (c) SEM of a sintered PZT-5H circular rod structure made by a lost mold method using Sanders Prototyping technique.....	17
Figure 4: (a) Photograph of PZT/eccogel composite with thin copper sheets and connecting wires attached.	18
Figure 4: (b) photograph of the final sensor assembly ready for loading tests.	18
Figure 4: (c)schematic of the cross section of sensor assembly in an aluminum channel.....	18
Figure 5: (a) Voltage response of PZT/eccogel composite sensor with time, on the application of a cyclic load changing from 0-5170 kPa at 18Hz (16 kph).....	19
Figure 5: (b) Voltage response of a PVDF sensor with time, on the application of a cyclic load changing from 0-5170 kPa at 18Hz (16 kph). ...	19
Figure 6: (a) Voltage response for a PVDF sensor assembly to a cyclic loading of 0-5170 kPa at 18 Hz and 27 Hz loading.	20
Figure 6: (b) Voltage response for a PZT composite sensor assembly to a cyclic loading of 0-5170 kPa at 18 Hz and 27 Hz loading.	20
Figure 7: Voltage response of a 0-5170 kPa cyclic loading on PZT composite and PVDF sensors with different loading frequencies at room temperature and 65°C.....	21
Figure 8: (a) MTS load simulation of the passing of a five axle truck with 9, 22, 22, 22, 22 kN loads each on a PZT composite sensor, at room temperature and a loading cycle of 18 Hz.	22
Figure 8: (b) MTS load simulation of the passing of a five axle truck with 9, 22, 22, 22, 22 kN loads each on a PVDF polymer sensor, at room temperature and a loading cycle of 18 Hz.	22
Figure 8: (c) MTS load simulation of the passing of a five axle truck with 9, 22, 22, 22, 22 kN loads each on a PVDF polymer sensor, at 65°C and a loading cycle of 18 Hz.	23

TABLES.....	24
Table 1: Contact area of the tire for different tire pressures.	24
Table 2: Total contact time and loading/unloading cycles per second for different vehicle speeds.	24
Table 3: Time to cover the distance between axles at different speeds for an ASTM class 51 truck.....	24
Table 4: Measured piezoelectric properties of PVDF polymer, bulk PZT-5H ceramic and PZT-5H/eccogel composite.	24

ABSTRACT

Weigh-in-motion (WIM) systems might soon replace the conventional techniques used to enforce weight restrictions for large vehicles on highways. Currently WIM systems use a piezoelectric polymer sensor that produces a voltage proportional to an applied pressure or load. Using this phenomenon, these systems are already being tested for collecting traffic data, including weigh-in-motion, measuring vehicle speeds, classifying vehicles by category and counting axles etc. The polymer sensors are usually in the form of a long tape or cable embedded within a long block of elastomeric material. These blocks are installed into grooves, which are cut into roads perpendicular to the traffic flow. The biggest disadvantage of the present sensor technology is that the piezoelectric output is not uniform with temperature and time, thus leading to large uncertainty in the data collected. On the other hand, piezoelectric ceramic materials have a much more stable response over a large temperature range. However, they are not used for traffic data sensors because of their inherent brittleness. Piezoelectric ceramic/polymer composites are made with an active piezoelectric ceramic embedded in a flexible non-active epoxy polymer. They hold a lot of promise for WIM applications because of their flexibility and excellent piezoelectric properties similar to that observed in bulk ceramics. In this research project, ceramic/polymer composite strips have been fabricated for use as piezoelectric sensors for measuring large loads. After encapsulating the polymer and composite sensors in elastomeric blocks in aluminum channels, the voltage outputs for different loads, loading rates and temperature conditions have been determined. Also, the composite and polymer sensor assemblies are being installed on a test road in order to perform actual measurements.

Key Words: Piezoelectric, sensors, weigh-in-motion (WIM), composites

INTRODUCTION

Conventional weighing techniques

There are many drawbacks to the present system of enforcement of weight restrictions for large vehicles on the major highways of the country. Historically tractor trailers and other large vehicles have traveled the highways virtually unchecked. Periodically, weigh stations on major highways are opened in order to enforce weight restrictions. However, when they are in operation many of the drivers for the larger trucking outfits purposely inform their colleagues via CB (citizens band) radio. Once known the weigh station is open, the drivers direct other overweight trucks around these stations to avoid lost trucking time, possible hassles, and fines. In a recent report, it was found that in Michigan about 57% of the heavy trucks exceeded the legal weight limit, but only 1% were caught at the weigh stations [1]. This discrepancy was found to be a result of overweight trucks bypassing the weigh station. Fines for overweight vehicles are generally a dollar a pound, and can easily total several thousand

dollars per violation that the trucking companies must pay. Therefore, it is in the trucking company's best interest to either keep their trucks under weight or somehow avoid getting weighed. This bypassing practice is unethical and not officially endorsed by the trucking companies, but nonetheless it occurs.

Once open, the operators of the weigh stations usually turn on a sign instructing drivers to pull off the highway and enter the weigh area. It usually takes anywhere from 30 seconds to 5 minutes to weigh each truck [2]. Once about 15 trucks have lined up in the station, it has to be closed to avoid traffic back-ups on the highway. Only after these trucks have cleared the weigh station, the operators reopen the station and direct trucks to pull off the highway once again. During one day of operation a large number of trucks are weighed, however many trucks simply 'get lucky' and are able to bypass the station while the operators are trying to handle the trucks already in the queue. In general, weigh stations are open at random to keep the trucking companies constantly on their feet. Hence, they are not open for even 40 hours a week, so they cannot offer proper and continuous monitoring of weight restrictions. Thus, many overweight trucks pass through the highway system everyday, a safety threat to the infrastructure and other vehicles.

There are other disadvantages to this system of collecting data. It is known that there is a lot of wear and damage to the asphalt roads caused by the stopping and starting of vehicles. The horizontal friction forces created by braking and acceleration of the trucks at the weigh stations can cause excessive rutting and shoving to occur in the vicinity of the station. The stopping of heavy tractor-trailers subjects the road to negative conditions that over time can accelerate the decay of the highway [3]. The impending wait in the queue also costs businesses a lot of money in delayed shipments.

Weigh-in-Motion systems

In order to overcome the problems related with traditional systems, many of the state DOTs (Department of Transportation) have looked at the possibility of using weigh-in-motion (WIM) systems to compute the weight of vehicles. WIM systems estimate a moving vehicle's gross weight that is carried by each wheel, axle, and/or axle group, by measurement and analysis of dynamic forces applied by its tires to a measuring device [2]. Presently most of these systems use piezoelectric polyvinylidene fluoride (PVDF) polymer sensors for the collection of traffic data. A polymer tape or cable is embedded within a long block of elastomeric material that is then installed in a narrow groove on the highway. The sensor receives a portion of the full load of the passing vehicle's weight and gives a voltage output that is translated into the weight of the truck. The biggest advantage offered by WIM sensors include the ability to continuously measure weights of the trucks traveling on the highway at various speeds, without diverting or stopping them. It can also keep a count of the number of vehicles, measure their speeds, classify them according to weight category, and detect the number of axles. Apart from the above applications, this type of sensors could also be used for parking area controls and tollbooth systems [4]. In spite of all the highlighted advantages the present WIM technologies using PVDF polymer sensors have two main drawbacks. The first is the variability in the voltage

output that is mainly attributed to temperature fluctuations. In order to incorporate voltage variations with temperature changes from day to night and different seasons, the piezoelectric sensors are calibrated and have a built in temperature correction. However, many times this technology cannot correct for the hysteresis that the PVDF WIM sensors experience and show readings that is way off the mark. The other major drawback is that the polymer sensors are more prone to physical damage under heavy loads leading to sensor failure. Based upon many recent WIM installations, the sensors do not seem to last their expected service life of about two years [4].

Principle of Piezoelectricity

The output variations and the premature failures of the WIM sensors are mainly related to the kind of piezoelectric sensor material used in the assembly. So it is important to understand the phenomena of piezoelectricity and know about the different types of piezoelectric materials available for use as sensors. This could help in avoiding the problems faced with the present technology.

The piezoelectric effect occurs in a number of single crystals, polymers and ceramics. The direct piezoelectric effect relates a change in the polarization (charge) to an applied stress, whereas the converse effect relates a dimensional change to an applied electric field. Piezoelectric sensors, which convert mechanical energy to electrical energy, have found applications as sensors in many areas including car tilt control, hydrophones, and lighters to name a few [5]. For WIM systems, a piezoelectric sensor assembly is embedded under the road, and the weight of the wheels of a vehicle passing on it leads to the creation of electrical charges on the opposite faces of the sensor. The total voltage generated due to the application of pressure depends on the properties of the piezoelectric material used for the sensor. They are related by,

$$P = C \cdot V \quad (1)$$

where P is the total polarization or charge, C is the capacitance of the sensor and V is the voltage generated. The amount of charge generated would depend on the piezoelectric charge coefficient 'd' of the material. For a sensor poled in the thickness direction and for pressure applied in the same direction, the piezoelectric charge coefficient would be equal to the d_{33} coefficient. The total polarization would then depend on the applied stress σ by the following relation,

$$P = d_{33} \cdot \sigma \quad (2)$$

In order to obtain a high voltage output, it is necessary to have a large charge output, for example by using a material with a high d_{33} coefficient. The total capacitance also should be low as it degrades the output voltage. Even though the capacitance of the cables are very low (100 pF/m) it should be kept as short as possible. However, in actual practice the cables from the sensors have to be routed from the roadway to the measurement electronics that is

usually at the edge of the highway. The voltage drop due to cable length increase has to be considered [6].

Piezoelectric Materials

At present the main materials used as piezoelectric sensors for WIM systems are strips of PVDF polymer. They give a moderate charge output. Their biggest advantage is that they are flexible and conformable to any shape. However, they have a low coupling constant, and are difficult to pole. This sensor only works at ordinary temperatures since PVDF has a Curie temperature (T_c) of 100°C and the dipolar orientation vanishes upon going above this temperature. In fact if the temperature gets close to T_c , PVDF will eventually depole. How long this will take depends on the temperature but the tape will not last long at 90°C , and most experience indicates that use above 60°C is not recommended. PVDF is also more delicate than conventional polymeric materials and can be damaged mechanically at high loads [7,8].

Among all piezoelectric materials, lead zirconate titanate (PZT) ceramics have shown the highest promise as a sensor material. This family of ceramics has high values for the piezoelectric charge coefficient (d_{33}), electromechanical coupling coefficient (k_t), Curie temperature (T_c) and dielectric constant (K). They also have low electrical losses. However, as PZT is a ceramic, it is brittle, non-flexible and non-conformable. So in spite of having excellent properties it has not found acceptance for use as WIM sensors.

Instead of looking for an entirely new class of piezoelectric materials without the above limitations, researchers in the last two decades have successfully developed composites of piezoelectric ceramics with flexible inactive polymers. These piezocomposites show excellent electromechanical properties while limiting the various detrimental properties of the monoliths. The properties of the ceramic/polymer composites can be tailored by changing the connectivity of the phases, volume fraction of the ceramic in the composite, and the spatial distribution of the active ceramic phase. By designing the right structure it is possible to obtain electrical properties that are as good as PZT and with the added flexibility as high as that observed in polymers [9].

The focus of this study has been to develop suitable sensors that are durable and accurate. Ceramic/polymer composite piezoelectric sensors were chosen to eliminate the problems seen in PVDF polymer sensors. A lost mold process was used to make rod type piezoelectric ceramic structures with a novel design. The sensors were completely flexible and could be bent nearly 180° without breaking or damaging them. The fabrication process of the ceramic structures and composites are described in detail in the next section. After electroding, poling, and bonding to thin copper sheets; the sensors were embedded in an aluminum channel with a high strength epoxy. Various loading tests were run on the embedded sensors using a Material Test System (MTS) machine to simulate the passing of vehicles on them. The fabrication, embedding, and electrical testing of these sensors have been discussed in this paper.

EXPERIMENTAL

Sensor fabrication

The piezoelectric ceramic-polymer composite sensor fabrication process is shown in figure 1. The ceramic structures were made using a lost mold technique. The final structure has PZT-5H ceramic rods embedded in a eccogel-65 epoxy matrix and poled parallel to the fiber orientation. In this method, a sacrificial wax mold having a negative of the desired structure is infiltrated with ceramic slurry. The slurry fills the open spaces in the wax. The mold is evaporated away during the early portion of the binder burnout step. After binder burnout is complete, the PZT ceramic structure is sintered. In this work, sacrificial molds were fabricated by the Sanders Prototyping (SP) technique.

The Sanders Prototype Model-Maker system MM-6PRO (Sanders Prototype Inc., Wilton, NH) was used to make polymer molds. This system uses a CAD file as input. The MM-6PRO is a liquid to solid inkjet plotter that deposits the polymer on a movable Z-platform. The molten polymers, a build polymer (used to make the mold) and a support polymer (used to support overhangs and cavities in the mold) are fed into heated nozzles, which move in the X-Y plane. After the mold is made, the support polymer is dissolved using a solvent that does not attack the build polymer. The main advantages of the SP technique include, molds with a very high resolution (mold wall thickness of $\sim 75 \mu\text{m}$ can be easily obtained), and good control over the surface finish.

A high solids loading of PZT ceramic slurry was specially developed to infiltrate the polymer molds to avoid cracking in the green sample during drying and binder burnout. A commercially available spray dried PZT-5H powder (Morgan Matroc Inc., Cleveland, OH) was used in this work. The powder was heat treated to remove the binder and then ball milled for an hour with water, dispersant (Darvan™-7, R. T. Vanderbilt & Co., Norwalk, CT) and antifoaming agent (1-Octanol, Fisher Scientific). After milling, an acrylic emulsion binder (Duramax™ B-1035, Rohm and Haas Co., Philadelphia, PA) was added to the system and mechanically stirred for five to ten minutes to insure homogeneous distribution of the binder in the slurry. Molds were infiltrated with the slurry and dried in an ambient atmosphere [10].

The green parts were heat treated to remove the mold polymer and the binder using a slow heating rate of $1^\circ\text{C}/\text{minute}$ from room temperature to 550°C in a furnace. Samples were sintered in a sealed crucible, heated at a rate of $3.5^\circ\text{C}/\text{minute}$ to 1285°C and soaked for one hour. The sintered structures were embedded in eccogel-65 epoxy (Ernest F. Fullam Inc., Latham, NY) and cured in an oven at 70°C for 12 hours in air. Samples were cut, polished, electroded and poled. Poling was accomplished using a corona poling apparatus at 60°C , 25 kV for 20 minutes with a needle to specimen separation distance of 4.5 cm. Electromechanical properties of composites including capacitance (C_p), d_{33} coefficient, and thickness coupling constant k_t were evaluated. Various architectures of the ceramic structures were also examined using a scanning electron microscope (Model 1400, Amray Corporation). The composite was glued to thin copper sheets 0.79 mm thick using a thermosetting silver epoxy.

Insulated copper wires were connected to the outer faces of the copper sheets to collect the charges.

Embedment of Sensor

Before installing the piezoelectric sensor on the road it needs to be encapsulated in an epoxy to protect it against the external environment. Some of the desired properties of the epoxy include resistance to road salts, gasoline, water, and temperature variations among others. Based on a recent report, the possible epoxies to use for the research were chosen [11]. The paper provides results of various tests conducted on eight different epoxies used with piezoelectric devices with a summary of the epoxy performances. A number of more recent epoxies that were not included in the report were also considered for embedding the sensor.

As the project progressed, a number of epoxies were ruled out as possible components of the piezo sensor. The main problem was the availability of the epoxies. Some of the epoxies were produced overseas, and could require additional shipping time. Likewise, other epoxies were produced by companies that also manufactured WIM sensor systems themselves. Using these epoxies could possibly lead to future availability problems. Another factor was the extremely low flash point of some of the chemical components of the epoxies. Eventually G-100 epoxy (E-Bond Epoxies Inc., Fort Lauderdale, FL) was chosen for this project. The epoxy has a minimum compressive strength of 55160 kPa, pot life of 30-40 minutes at 25°C, usable cure time of two hours at 25°C and an ultimate cure time of five days at 25°C.

The piezo sensor was wrapped with a Teflon[®] tape to prevent any short circuiting from occurring, and to avoid any shearing between the copper sheet and the composite during use. The sensor needed supports to be placed in the center of the aluminum channel as shown in figure 1. Chairs 0.25 cm thick x 1.25 cm tall x 1.90 in size were cut from a block of fully cured G-100 epoxy to support the sensor. An aluminum channel was cut to the desired size, about 2.54 cm longer than the piezoelectric sensor, and roughened up on the inside to ensure a strong bond between the metal and epoxy. The sensor was positioned at the center of the channel. A few drops of super glue were applied to the chairs to bond them to the channel on one side and the sensor on the other. The ends of the channels were sealed with cardboard with a hole on one side to allow the sensor wires to pass through. The components of the G-100 epoxy were then proportionally measured in a 1:25 ratio by weight, and mechanically mixed for five minutes to ensure a thorough blend. The channel with the sensor inside was then placed on a vibratory table and infiltrated with G-100 epoxy. The epoxy was then allowed to cure at room temperature for 24 hours. The electrical properties of the PZT piezoelectric ceramic/polymer composite sensors were compared with a poly vinylidene fluoride (PVDF) sheet sensor (Raytheon Company, Lexington, MA). The PVDF sensor assembly was made in the same way as the composite embedding.

Loading Tests

All testing was conducted on a 222 kN, 810 MTS universal machine (MTS Systems Corp., Eden Prairie, MN) with TRS 2000 operating software and an environment control chamber as shown in figure 2. The loading measurements were taken at temperatures ranging from room temperature (23°C) up to 65°C in 10°C increments. These tests were conducted only after allowing the chamber air temperature to stabilize at the set temperature for a minimum of 10-15 minutes. This paper only presents the results of the tests run at room temperature and 65°C. For the latter testing, the sensor was allowed to stabilize for at least 30 minutes before applying any loading.

The data included in this report is from sensors with approximately the same surface dimensions attached to wires two meters long. The standard piezo sensor surface dimension was 7.60 cm x 1.07 cm, embedded in an assembly with a top cross section of 10.16 cm x 1.91 cm, unless stated otherwise. The embedded sensor was placed on a platen, attached to the MTS piston, designed with a ball and socket joint to avoid torsional effects. A second platen attached to the head of the MTS machine was moved, to just bring it in contact with the surface of the epoxy. A very small pre-load, approximately 89 to 134 N, was applied to mainly hold the sensor in place during the testing. A dynamic load was then applied to the sensor at different frequencies and under several different loading patterns. A Krenz processing storage oscilloscope, PSO 5070 with TRS 2000 operating software (Krenz Electronics, Hirzenhain, Germany) was used as a data acquisition device. The Krenz acquired voltage, time, and load readings while the testing was being conducted. The voltage readings were directly from the sensor being tested, without any amplifiers. The load readings were acquired from the control console for the MTS.

While modeling the sensor loading tests in the laboratory, it was important to consider the actual contact area of the truck tire on the roadway [12]. The contact area of the tire with the road is calculated as the total load carried by the tire divided by the tire pressure [13]. The tire pressure is variable, ranging anywhere from 3 to 8 bar with an average range of 4.8 to 6.2 bar [14]. Table 1 shows the contact area of the tire for different tire pressures at a fixed load of 22kN. These values are an approximation that may not fully account for the shape effects, such as centrifugal acceleration and the steel belts in the radial tires. However, as long as the loading conditions are the same, for purposes of comparing the PZT composite and the PVDF polymer the error will cancel out.

According to ASTM standards E1318 a Type I weigh in motion system must be capable of detecting a minimum truck load of 267 kN, axle group load of 111 kN, a single axle load of 54 kN, and a wheel load (half axle load) of 22 kN [15]. These are the minimum values, because WIM is used for enforcement of weight restrictions and as long as the truck is under the weight limit it is of little value to measure its precise weight. In the lab experiments a cyclic load of 5170 kPa was applied to the sensor assemblies. This loading criterion was based on ASTM standard E1318 and work done by other researchers [16]. Using the ASTM standards, the typical load on a front tire would be the half axle load that translates to 22 kN on each tire. Based on field measurements an average

tractor trailer tire is approximately 22.86 cm wide. Therefore if the full load of 22 kN was to be applied over 22.86 cm of length of the 1.91 cm wide sensor assembly, the sensor would need to be capable of measuring approximately 5170 kPa.

Assuming an average tire pressure of 6 bar (Table 1), for a contact area of 385 cm² it was calculated that the length of the tire that comes in contact with the roadway is approximately 25.4 cm based on the equation [13].

$$L = (A_c / 0.5227)^{0.5} \quad (3)$$

The amount of time that it takes to load and unload the sensor is equal to the amount of time it take to fully move the tire footprint onto and off of the sensor. Hence, the time taken for one full loading/unloading cycle can be calculated by dividing the length of tire by the speed of the vehicle. Table 2 shows the contact time and the number of cycles per second for different vehicle speeds. These frequencies have been taken as the predominant operating frequencies of the truck loading simulations. In real life conditions the sensor may be subjected to numerous frequencies during just one cycle. However, the sensor was tested with a single predominate frequency model. This single frequency model is only an approximation, which neglects variables that may effect performance of the sensor. In actual field trials the sensor will be subjected to such variables as the truck suspension, which can causes the truck itself to oscillate at frequencies between 0.5-4 Hz thus adding to the predominant frequency caused by the trucks speed [17].

According to ASTM standards E1318 the Type I WIM system must be capable of detecting a truck load traveling at speeds between 16 kph and 113 kph. The MTS testing machine used for this research has a limitation of 80 Hz that is equivalent to 72 kph. In this study only low frequency loading upto 27 Hz was evaluated. The high speed measurements will be carried out in the actual field test. In order to simulate the loading of the sensor, an ASTM class 51 truck with five axles was chosen. Table 3 shows the time to cover the distances between consecutive axles for different vehicle speeds. The minimum specified ASTM axle distances 2.5, 0.6, 3.5, 0.6, and 7.0 m were used for the time calculations. The smaller spacing will decrease the amount of time that the sensors have to react, thus demonstrating their ability to re-stabilize quickly.

RESULTS AND DISCUSSION

Piezoelectric Sensor

The main requirement for the piezoelectric material in the weigh-in-motion (WIM) sensor assembly is the flexibility of the sensor to avoid any cracking during use. Piezoelectric ceramic/polymer composites are best suited for use in this application because of the advantages mentioned earlier. For the initial tests, the composites were made by a dice and fill technique to form square ceramic rods. This method was very fast and is commercially used for the fabrication of a large percentage of piezocomposites. However, as a soft and flexible eccogel-65

epoxy was being used for this work, there was delamination between the ceramic and the polymer forming cracks in the sample. This could be because of the nature of the composite design (Figure 3(a)), and the smooth ceramic walls causing poor bonding between the ceramic and epoxy. Lot of cracks appeared in the sample when it was subjected to shear forces during polishing and handling. In order to overcome this problem, composites with circular rods (Figure 3(b)) were made by a lost mold method using the SP technique described earlier. The scanning electron microscope (SEM) photograph of the structure in figure 3(c) shows cylindrical rods of PZT having a diameter of $\sim 700 \mu\text{m}$ and separated by nearest neighbor distance of $\sim 400 \mu\text{m}$ between the ceramic walls. The sanders molds were designed to provide a rough surface to the final sintered ceramic rods in order to insure a good bonding of PZT with the eccogel epoxy. The final composite made from this structure would have a ceramic volume fraction of approximately 0.48. This architecture did not show any damage even after rough handling and hence has a higher probability of completing its service life in the field than PVDF.

The average measured piezoelectric properties of bulk PZT-5H, PVDF sensor obtained from Raytheon and PZT ceramic/eccogel polymer composite, are presented in table 4. It can be seen that the piezocomposites have a very high d_{33} value approaching that of the ceramic while the same coefficient was ten times lower for the PVDF polymer. The composites also have a very high thickness-coupling factor of 67 % as compared to only 25 % for the polymer. This implies that the conversion efficiency of the mechanical stresses to electrical charges is more efficient for the composite sensor. The Curie temperature of the composite would be same as the ceramic PZT- 5H that is around $190\text{-}200^\circ\text{C}$. Consequently, this sensor can be used over a much wider temperature range and would be more difficult to depole, thus reducing variability in the voltage output at different temperatures. The composites also are more resistant to damage than PVDF due to their rugged design.

Figure 4(a) shows a photo of a 7.6 cm long PZT-5H/eccogel-65 composite sensor with thin copper foils attached to both sides. The connecting wires were attached to the copper sheets with a thermosetting silver epoxy to collect all the charges and prevent any bonding failures during application. Figure 4(b) shows the photo of the sensor embedded in G-100 epoxy in an aluminum channel. The PZT sensor is near the middle of the channel as shown in the schematic of figure 4(c).

Loading Results

The finished sensors like the one shown in figure 4(b) were taken and the epoxy on the top surface was polished to ensure that it was smooth and parallel to the base of the aluminum channel. This was done to prevent the generation of any concentrated loading of any one area of the sensor when testing in the MTS machine. The pressure loading tests were run on the sensors based on the conditions described in the experimental section.

Figure 5(a) and 5(b) show the voltage responses of the PZT ceramic/eccogel polymer composite and PVDF sensor assemblies at room temperature, on the application of a cyclic load sinusoidally changing from 0-

5170 kPa at 18Hz which is equivalent to 16 kph. It can be seen that for the same size sensors, under the same loading conditions, the average loading output of the composite sensor is about 3V as compared to only 1V for the PVDF sensor. This could be because of the superior electrical properties of the composite, including a higher d_{33} and thickness-coupling coefficient. The signal to noise ratio would be much better for a composite and hence would give it the ability to detect much lower load differences with a greater accuracy. It can be observed from the figures that the voltage response for the sensors was not exactly the same for each cycle. This could be due to a small 50 Hz signal detected within the acquired data from the testing. It implies that some electrical component operating at 50 Hz was interfering and altering the sensor signal. Since the electrical devices in the lab such as computers, load cells, and fluorescent lights will not be present in real life these variations can be neglected.

The response time of the sensor to a dynamic loading would determine its feasibility for use in actual road applications. Table 2 and 3, show the sensor/tire contact times and time to cover distance between axles for different vehicle speeds. Depending on the speed, the tire contact time could range from 8–58 ms and the sensor would have between 20 to 136 ms to fully stabilize before the next axle load falls on it. In the worst case scenario for a truck traveling at 113 kph, the sensor will produce erroneous readings if it cannot respond in 8 ms and fall back to zero voltage within 20 ms of the removal of the load.

Figure 6 (a) shows the voltage versus time response for the PVDF sensor assembly for the same peak loading at two different frequencies. It can be seen that at both 18 Hz and 27 Hz loading frequencies the voltage response of the PVDF sensor does not follow the sinusoidal loading/unloading curve. The highest/lowest voltages are observed not at the largest/smallest loading points but at the maximum/minimum loading rates, which are at the inflection points of the load time curve. For the same total maximum load, the voltage output is found to increase on increasing the loading rate from 186 MPa/s (18 Hz) to 279 MPa/s (27 Hz). It can also be observed from figure 6(a) that the polymer sensor is very sensitive and responds very fast to loading, however the voltage does not completely fall back to zero before the next loading cycle begins. This could cause problems in accurately recording the weights of fast moving vehicles.

On the other hand, PZT composite sensors have a response time that is much slower than the polymer sensors for the same loading conditions. As shown in figure 6(b), for the 18 Hz loading condition, the sensor does not show any output reading till the loading rate reaches the maximum value. However, the voltage then rises to a maximum and falls down at a very fast rate regaining the stable zero voltage condition before the next loading cycle begins. A similar trend is observed on increasing the frequency to 27 Hz, thus proving that a composite sensor would give more accurate weight readings because of its ability to stabilize faster at different loading conditions.

In a practical application the WIM sensor would be installed on a highway where the temperature conditions might change daily and from season to season. The Federal Highway Administration (FHWA) conducted a ten year survey of New Jersey highway asphalt temperatures, by monitoring numerous

sampling locations throughout the state. The FHWA results indicate that depending upon the season the average road temperatures varied from a low of -34°C in winter to 64°C in summer within a 98% reliability [18]. The G-100 epoxy is designed to withstand extreme temperatures and also most piezoelectric materials have a stable response at low temperatures [19]. However, it is important to study the sensor behavior at higher temperatures as piezoelectric materials have a tendency to depolarize near the Curie temperature and hence give erroneous readings. Figure 7 shows the voltage response of the PVDF and PZT composite sensors to a cyclic loading of 5170 kPa at different loading rates and temperature conditions. The loading rates simulate the different speeds at which the vehicles might be moving on the highway. It can be observed from the graph that the voltage output at room temperature increases linearly for both the sensors with an increase in the frequency of loading. Thus the polymer and composite sensor voltages can be easily calibrated to read the weights of trucks based on the speed of the vehicle (loading rate), and the load on the sensor (based on tire contact area data). In all cases the PZT ceramic/eccogel composite sensor had a higher output than the PVDF polymer sensor for the same temperature and loading rates for reasons explained earlier. On increasing the temperature to 65°C , there is more than a four-fold jump in output for the PVDF sensor as compared to a two-fold increase for the composite sensor. The voltage output with increasing frequency is still linear for both the sensors. The big jump in the PVDF sensor output could be attributed to a large increase in the d_{33} coefficient at higher temperatures, as compared to a moderate rise for the ceramic PZT in the composite sensor [20-22]. The biggest problem is observed when the temperature approaches the Curie temperature (T_c) where the aligned electric dipoles in the piezoelectric sensor are easier to rotate. This could lead to depoling the piezoelectric material under heavy loads and hence a degradation in the sensor performance. As PVDF has a T_c of only 100°C it could easily lose part of its piezoelectric properties at high loads at temperatures as low as $55-65^{\circ}\text{C}$. The WIM system electronics have calibration programs that convert the voltage readings to calculate the equivalent tire, axle, and truck weights. If the sensor depoles it would give erroneous weight readings. The PZT ceramic/polymer composite sensor is more rugged with a much higher T_c of $\sim 190^{\circ}\text{C}$.

Using both the PZT ceramic/eccogel polymer composite and PVDF sensor, it was decided to simulate the loading condition of an actual truck with five axles passing on the sensor assembly. The MTS machine was used to generate loads of 9, 22, 22, 22, 22 kN to simulate pressure from a tire of each axle. As a simplification, the entire tire load was assumed to be carried by the sensor assembly. The loading condition was for an ASTM class 51 truck traveling at 16 kph and with axle distances as shown in table 3. It can be seen in figures 8(a) and 8(b) that both the polymer and ceramic sensors are able to detect the loads very accurately. As mentioned earlier, the ceramic sensor has an advantage in its ability to detect smaller load differences more accurately. On increasing the temperature of the assembly to 65°C , the PVDF sensors readings increased drastically (Figure 8(c)) as compared to a nominal increase in the PZT

composite sensor. In fact after repeated running of the tests at the higher temperature a small drop in the PVDF sensor readings was observed.

CONCLUSIONS AND FUTURE WORK

In this project, piezoelectric composite sensors were tested for possible use as weigh-in-motion (WIM) sensors in highways. Piezoelectric composites offer a lot of advantages over the PVDF sensors including a higher voltage output, higher Curie temperature, resistance to mechanical damage and tolerance of much higher loads. Although composite sensors take a longer time to respond to a load, they also recover very fast before the next loading cycle. The initial laboratory tests show that the PZT composite sensors performance to be better than or at par to the commercially available PVDF sensors currently used. The composites show a lot of promise to be used for practical applications. At this time, work is underway in our laboratory to fabricate a large sensor for installation on a road site to compare with MTS simulation results.

REFERENCES

1. N. Nassif, A. Nowak, in International Bridge Conference, p. 110 (1995)
2. C. E. Lee, ASTM Standardization News, 19, 32, (1991)
3. F. Roberts, P. Kandhal, E. Brown, D. Lee, T. Kennedy, *Hot Mix Asphalt Materials, Mixture Design and Construction*, (NAPA Research and Education Foundation, Lanham, MD, 1994), p. 416
4. Product Data Sheet, Roadtrax™ series P and TP piezoelectric polymer traffic sensor, Number 29, Atochem Sensors Inc., Piezo film sensor division, Valley Forge PA
5. A. Safari, J. Physics III France, 4, 1129 (1994)
6. G. Bailleul, in National Traffic Data Acquisition Conference, vol 2, p. 596, (1996)
7. W. A. Smith, in New developments in ultrasonic transducers and transducer systems, edited by L. Lizzi, (SPIE Proceedings, 1733, San Diego, CA 1992), p. 1
8. Y Bar-Cohen, T. Xue, S. S. Lih, Ultrasonic Transducer Online Journal, Sep 1996
9. V. F. Janas, and A. Safari, Journal of American Ceramic Society., 78, 2945 (1995)
10. A. Bandyopadhyay, R. K. Panda, V. F. Janas, S. C. Danforth, and A. Safari, Journal of American Ceramic Society, 80, 1366 (1997)
11. D. W. Fowler, in National Traffic Data Acquisition Conference, vol. 2, pp. 488, (1996)
12. N. Ali, J. Trogdon, and A. T. Bergan, Canadian Journal of Civil Engineering, 21, 156 (1994)
13. Y. H. Huang, *Pavement Analysis and Design* (Prentice Hall Book Company, Englewood Cliffs, NJ, 1993), p. 29
14. D. Croney and P. Croney, *The design and Performance of Road Pavements 2nd ed.* (McGraw-Hill Book Company, New York, 1991), p. 37
15. ASTM E1318, ASTM committee 17 on Pavement Management Technologies, 1993
16. M.C. Navarrete and E. Bernabeu, Sensors and Actuators, 41, 110 (1994)
17. W. D. Cunagin, Transportation Research Board, p. 1, (1986)
18. FHWA – DP 90 Asphalt Mix Design and Field Management Database, 1997
19. G-100 Product Data Sheet, E-Bond Epoxies Inc., Fort Lauderdale, FL
20. K. Omote, H. Ohigashi, and K. Koga, Journal of Applied Physics, 81, 2760 (1997)
21. P. Guthner, T. Ritter, and K. Dransfeld, Ferroelectrics, 127, 1343 (1992)
22. S. Zhang, X. Dong, and S. Kojima, Japanese Journal of Applied Physics, Part 1R, 36, 2294, 1997

DESCRIPTION OF FIGURES

Figure 1: Schematic of the process for making the embedded piezoelectric ceramic-polymer composite sensor.

Figure 2: Photograph showing the setup of the MTS machine with an environmental control chamber.

Figure 3: (a) Schematic of a top view of a rod composite with square rods showing cracking in the epoxy ceramic interface (b) schematic of top view of rod composite with circular rods (c) SEM of a sintered PZT-5H circular rod structure made by a lost mold method using Sanders Prototyping technique.

Fig 4(a) Photograph of PZT/eccogel composite with thin copper sheets and connecting wires attached (b) photograph of the final sensor assembly ready for loading tests (c) schematic of the cross section of sensor assembly in an aluminum channel.

Fig 5(a): Voltage response of PZT/eccogel composite sensor with time, on the application of a cyclic load changing from 0-5170 kPa at 18Hz (16 kph)

Figure 5(b): Voltage response of a PVDF sensor with time, on the application of a cyclic load changing from 0-5170 kPa at 18Hz (16 kph)

Figure 6(a): Voltage response for a PVDF sensor assembly to a cyclic loading of 0-5170 kPa at 18 Hz and 27 Hz loading.

Figure 6(b): Voltage response for a PZT composite sensor assembly to a cyclic loading of 0-5170 kPa at 18 Hz and 27 Hz loading.

Figure 7: Voltage response of a 0-5170 kPa cyclic loading on PZT composite and PVDF sensors with different loading frequencies at room temperature and 65°C.

Figure 8(a): MTS load simulation of the passing of a five axle truck with 9, 22, 22, 22, 22 kN loads each on a PZT composite sensor, at room temperature and a loading cycle of 18 Hz.

Figure 8(b): MTS load simulation of the passing of a five axle truck with 9, 22, 22, 22, 22 kN loads each on a PVDF polymer sensor, at room temperature and a loading cycle of 18 Hz.

Figure 8(c): MTS load simulation of the passing of a five axle truck with 9, 22, 22, 22, 22 kN loads each on a PVDF polymer sensor, at 65°C and a loading cycle of 18 Hz.

FIGURES

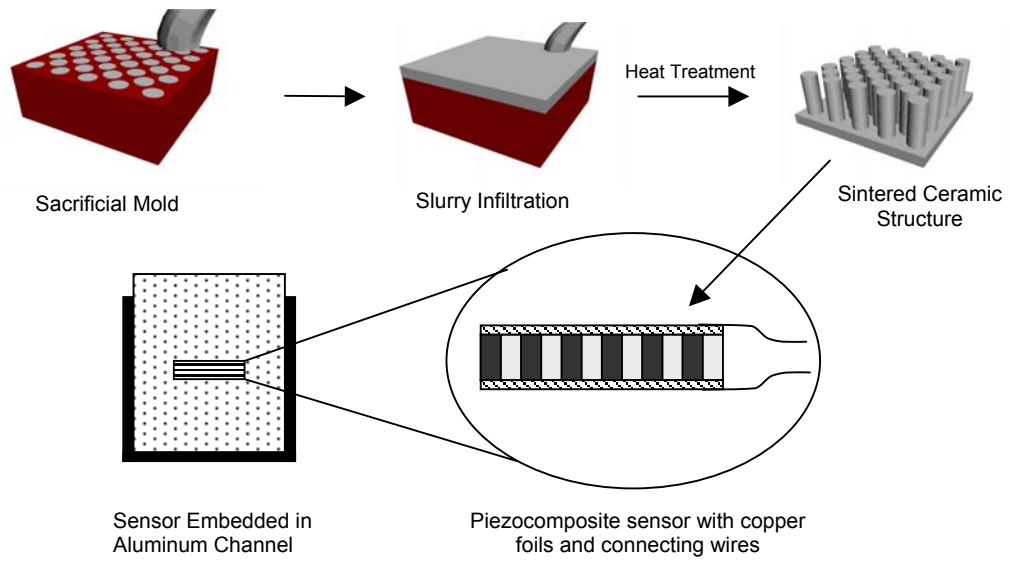

Figure 1: Schematic of the process for making the embedded piezoelectric ceramic-polymer composite sensor.



Figure 2: Photograph showing the setup of the MTS machine with an environmental control chamber.

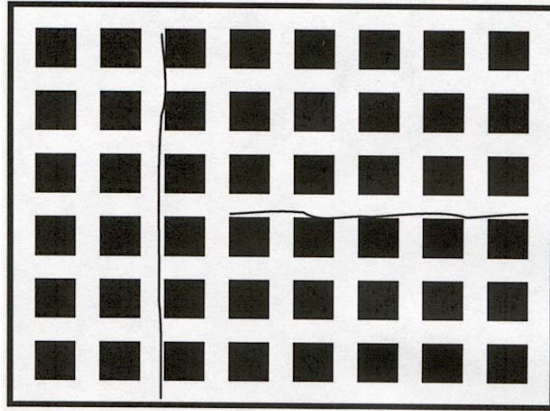

Figure 3: (a) Schematic of a top view of a rod composite with square rods showing cracking in the epoxy ceramic interface.

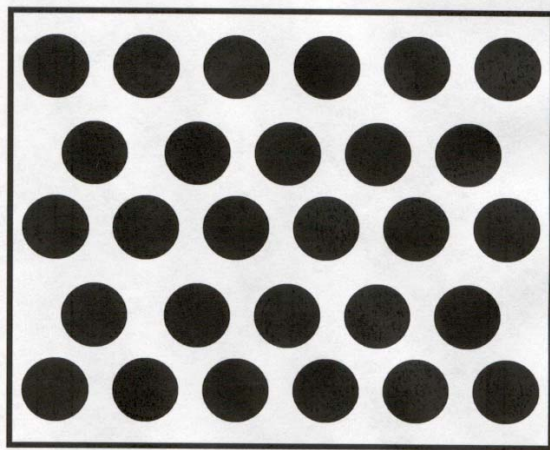

Figure 3: (b) Schematic of top view of rod composite with circular rods.

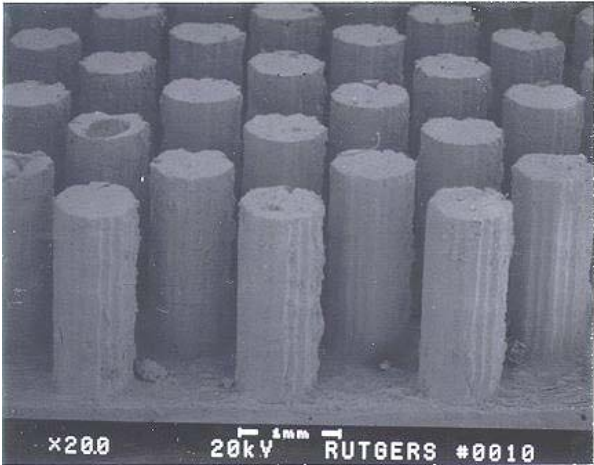

Figure 3: (c) SEM of a sintered PZT-5H circular rod structure made by a lost mold method using Sanders Prototyping technique.

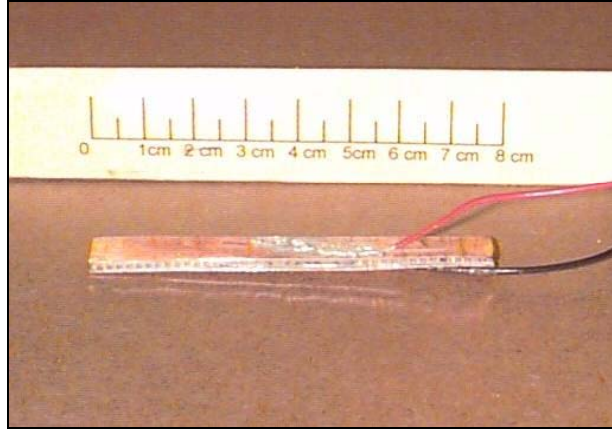

Figure 4: (a) Photograph of PZT/eccogel composite with thin copper sheets and connecting wires attached.



Figure 4: (b) Photograph of the final sensor assembly ready for loading tests.

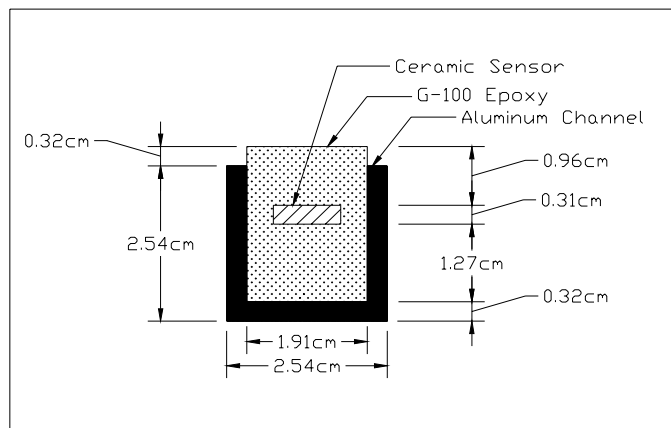

Figure 4: (c) Schematic of the cross section of sensor assembly in an aluminum channel.

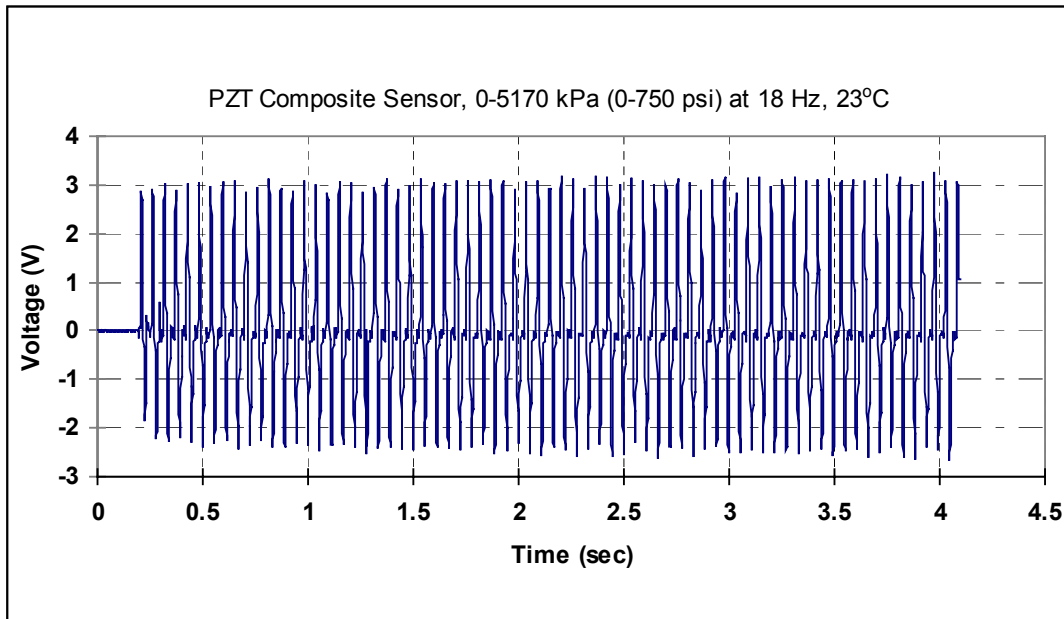

Figure 5: (a) Voltage response of PZT/eccogel composite sensor with time, on the application of a cyclic load changing from 0-5170 kPa at 18Hz (16 kph).

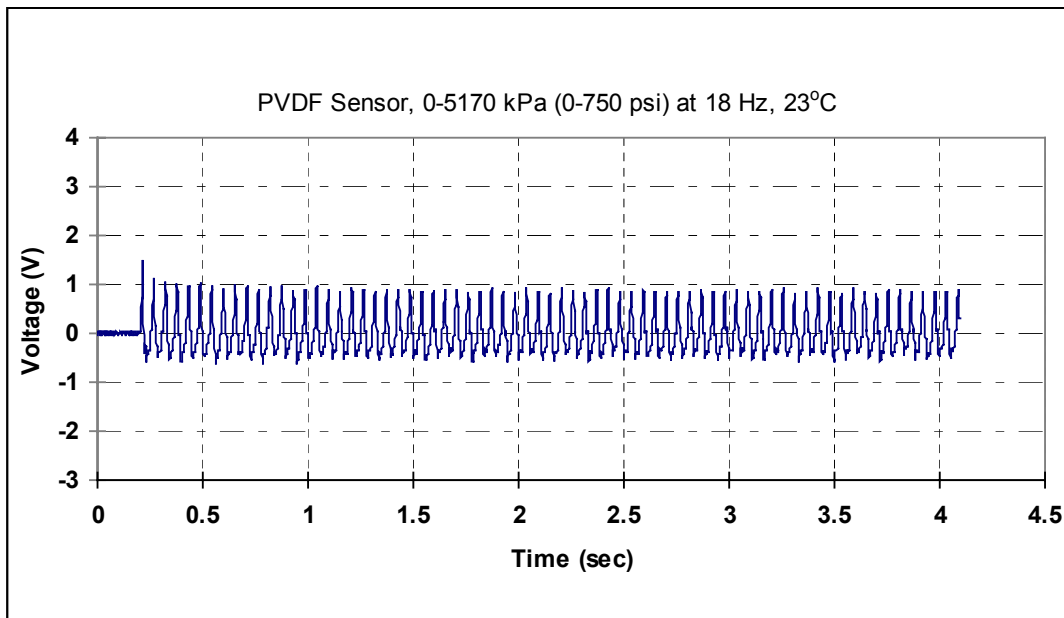

Figure 5: (b) Voltage response of a PVDF sensor with time, on the application of a cyclic load changing from 0-5170 kPa at 18Hz (16 kph).

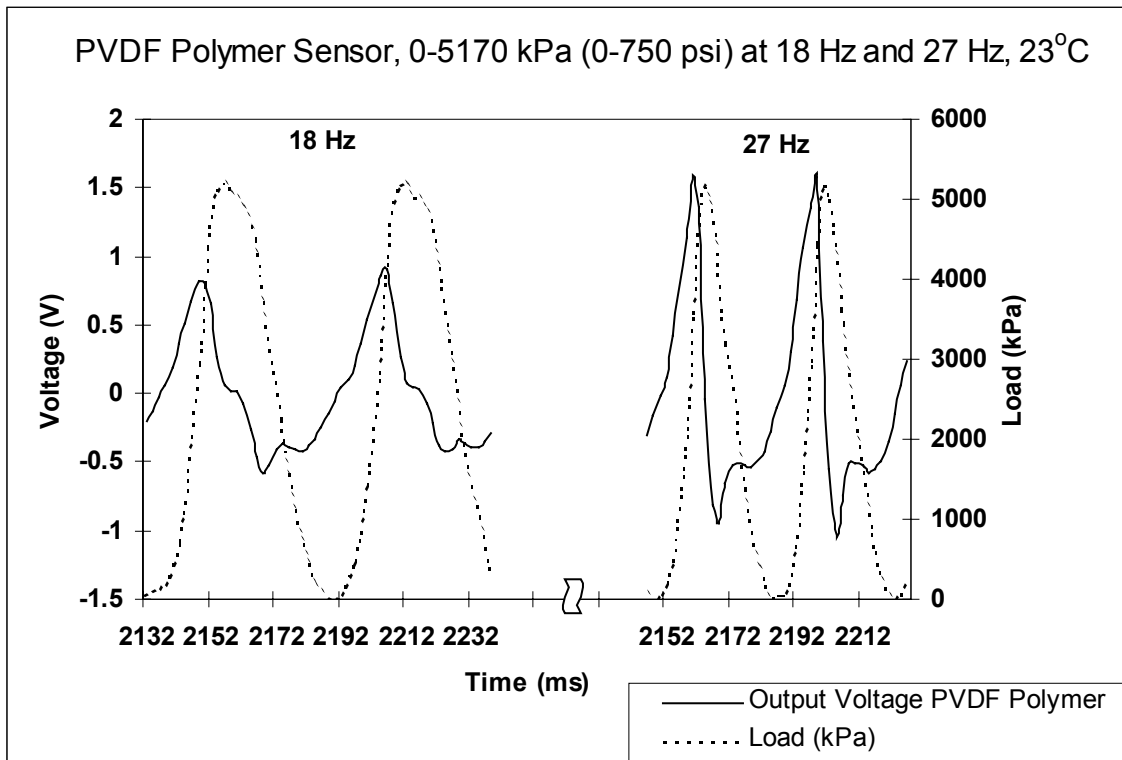

Figure 6: (a) Voltage response for a PVDF sensor assembly to a cyclic loading of 0-5170 kPa at 18 Hz and 27 Hz loading.

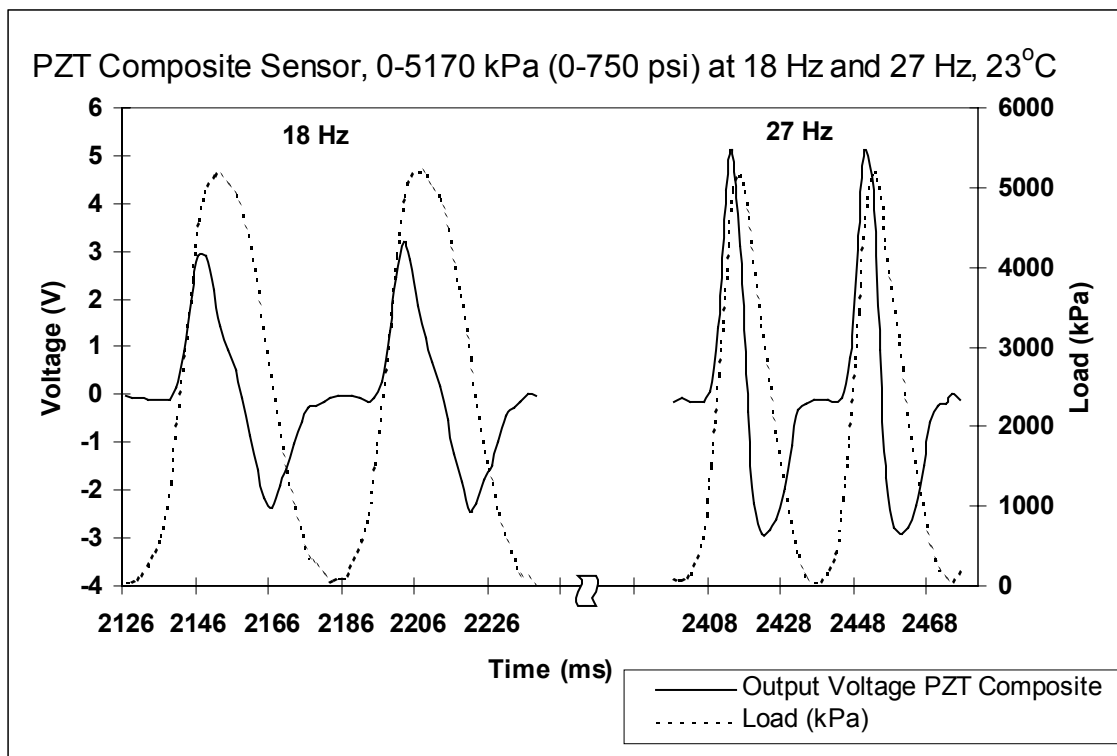

Figure 6: (b) Voltage response for a PZT composite sensor assembly to a cyclic loading of 0-5170 kPa at 18 Hz and 27 Hz loading.

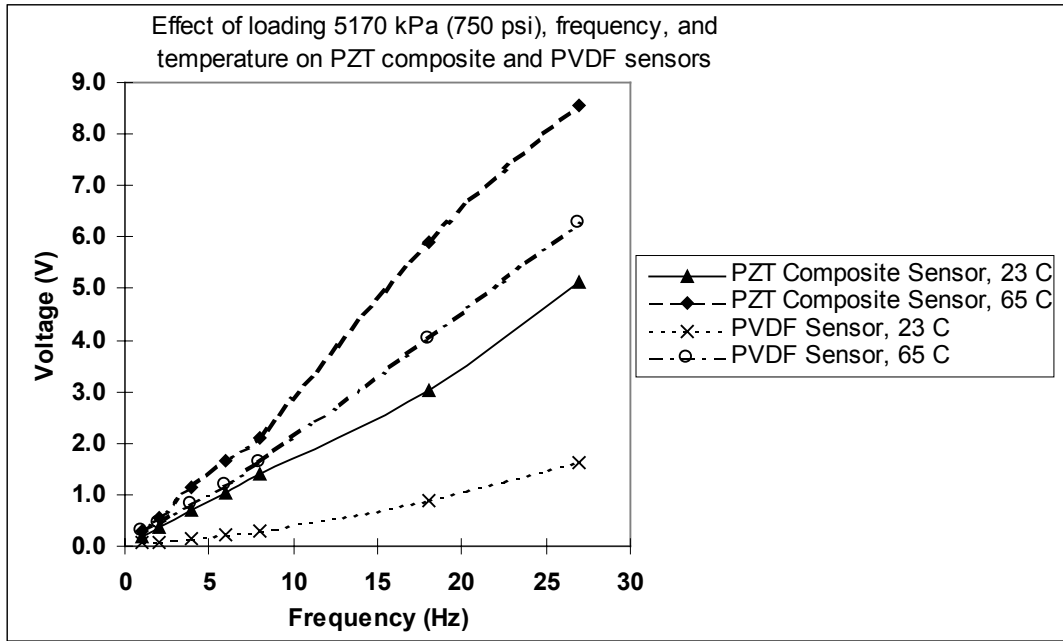

Figure 7: Voltage response of a 0-5170 kPa cyclic loading on PZT composite and PVDF sensors with different loading frequencies at room temperature and 65°C.

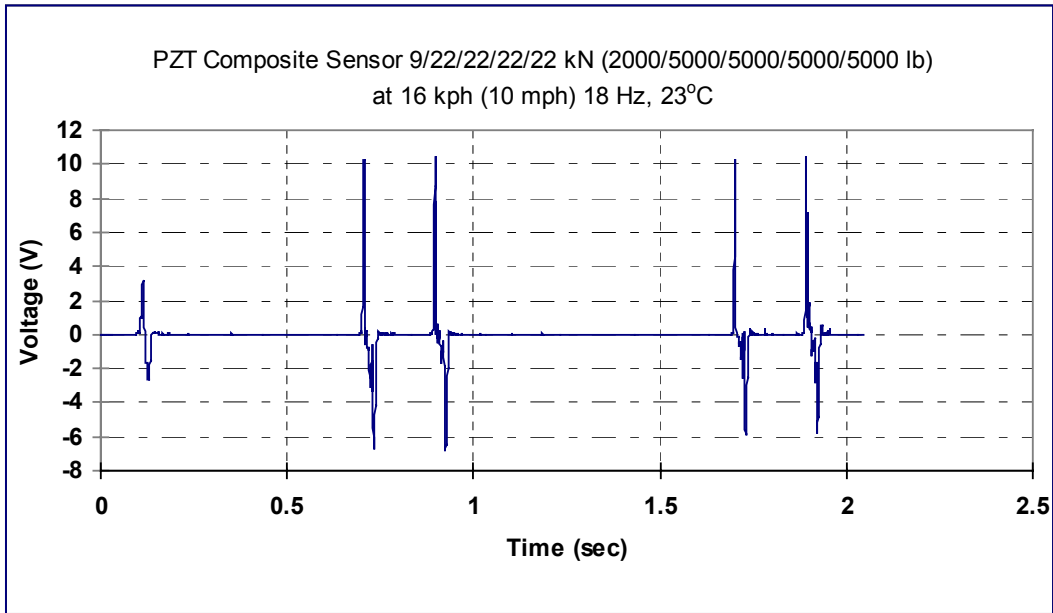

Figure 8: (a) MTS load simulation of the passing of a five axle truck with 9, 22, 22, 22, 22 kN loads each on a PZT composite sensor, at room temperature and a loading cycle of 18 Hz.

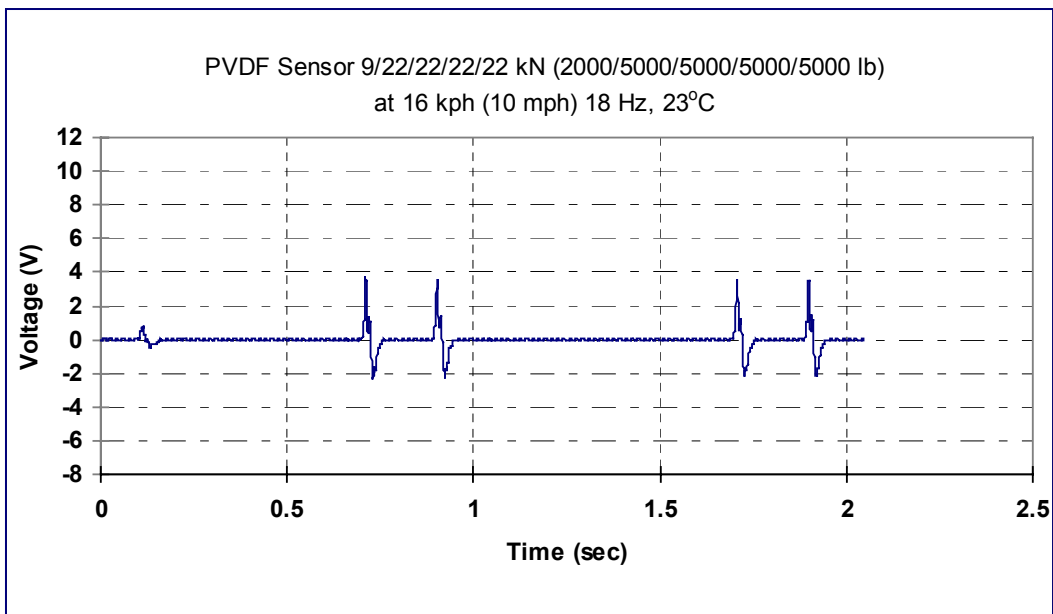

Figure 8: (b) MTS load simulation of the passing of a five axle truck with 9, 22, 22, 22, 22 kN loads each on a PVDF polymer sensor, at room temperature and a loading cycle of 18 Hz.

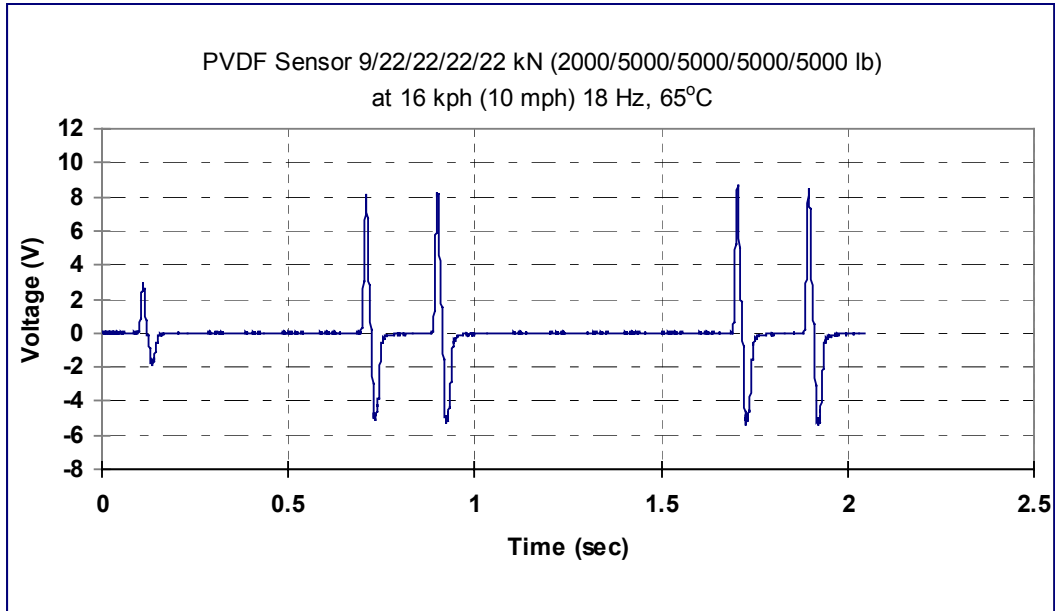

Figure 8: (c) MTS load simulation of the passing of a five axle truck with 9, 22, 22, 22, 22 kN loads each on a PVDF polymer sensor, at 65°C and a loading cycle of 18 Hz.

TABLES

Table 1: Contact area of the tire for different tire pressures.

TIRE LOAD = 22 kN									
Tire pressure (bar)	3	3.5	4.1	4.8	5.5	6.2	6.9	7.6	8
Contact area of tire with roadway (cm ²)	748	645	536	458	407	361	323	290	277

Table 2: Total contact time and loading/unloading cycles per second for different vehicle speeds.

Vehicle Speed (kph)	Tire Contact Length (cm)	Contact Time (ms)	Frequency Response (Hz)
16	25.4	56.8	18
72	25.4	12.6	80
113	25.4	8.1	123

Table 3: Time to cover the distance between axles at different speeds for an ASTM class 51 truck.

Axle Numbers	Spacing between axles (m)	Time to cover the distance between axles (ms)		
		16 kph	72 kph	113 kph
A ₁ – A ₂	2.5	545	121	78
A ₂ – A ₃	0.6	136	30	20
A ₃ – A ₄	3.5	750	167	107
A ₄ – A ₅	0.6	136	30	20
Total A ₁ – A ₅	7.0	1567	348	225

Table 4: Measured piezoelectric properties of PVDF polymer, bulk PZT-5H ceramic and PZT-5H/eccogel composite.

Material	d ₃₃ (pC/N)	K	tan δ (%)	k _t (%)	T _c (°C)
PVDF polymer	-33	6.5	2.0	25	100
PZT – 5H ceramic	550	2800	2.0	50	190
PZT-5H / Eccogel-65 composite (48 vol %)	380	450	6.0	67	190