

**BRIDGE APPURTENANCES**  
**Part A: Energy Absorbing Fender Systems**  
**Part B: Pre-Cast or Prefabricated Bridge Deck Systems**  
**Part C: Smart Bridges**

FINAL REPORT  
July 2003

Submitted by

Neville A. Parker, Ph.D., P.E.  
Professor and Director  
CUNY Institute for Transportation Systems  
The City College, New York

Farhad Ansari, Ph.D., P.E.  
Professor and Head  
Department of Civil & Materials Engineering  
University of Illinois, Chicago



NJDOT Research Project Manager  
Anthony Chmiel

In cooperation with

New Jersey  
Department of Transportation  
Division of Research and Technology  
and  
US Department of Transportation  
Federal Highway Administration

## **DISCLAIMER STATEMENT**

“The contents of this report reflect the views of the authors who are responsible for the facts and the accuracy of the data presented herein. The contents do not necessarily reflect the official views or policies of the New Jersey Department of Transportation or the Federal Highway Administration. This report does not constitute a standard, specification or regulation.”

1. Report No. <b>FHWA-NJ-2003-011</b>		2. Government Accession No.		3. Recipient's Catalog No.	
4. Title and Subtitle <b>BRIDGE APPURTENANCES</b> Part A: Energy Absorbing Fender Systems Part B: Pre-Cast or Prefabricated Bridge Deck Systems Part C: Smart Bridges				5. Report Date <b>July 2003</b>	
				6. Performing Organization Code <b>CUNY</b>	
7. Author(s) N. A. Parker, F. Ansari, M. Ghosn, K. Subramaniam, S.J.M. Meja, B. Quinlan				8. Performing Organization Report No. <b>FHWA-NJ-2003-11</b>	
9. Performing Organization Name and Address  CUNY Institute for Transportation Systems The City College of the City University of New York Convent Avenue & 138 <sup>th</sup> Street New York, NY 10031				10. Work Unit No. <b>1/2002 to 2/2003</b>	
				11. Contract or Grant No.	
12. Sponsoring Agency Name and Address  New Jersey Department of Transportation PO 600 Trenton, NJ 08625  Federal Highway Administration U.S. Department of Transportation Washington, D.C.				13. Type of Report and Period Covered	
				14. Sponsoring Agency Code	
15. Supplementary Notes					
16. Abstract This report presents the findings and recommendations for the following NJDOT's technology transfer projects: <b>Energy Absorbing Fender Systems</b> Existing bridge fender protective systems technology, used by other states and countries are grouped into six main categories: 1) Pile supported; 2) Retractable; 3) Rubber; 4) Gravity; 5) Hydraulic/pneumatic; and 6) Floating systems. A protection system composed of <b>hardcore composite pile dolphins, composite tubular piles with stay-in-place formwork surrounded by composite ultra-high molecular-weight faced fender panels</b> , was recommended as the state-of-the-art system for NJDOT, after rating six generic design alternatives based on their life cycle costs. <b>Pre-Cast or Prefabricated Bridge Deck Systems</b> It was found that more than 50% of U.S. bridges are classified as pre-stressed concrete structures. The study concluded that precast bridge decks have several advantages over cast-in-place structures, including faster construction schedules, longer service lives, and potentially greater cost efficiency. The use of precast bridge decks in conjunction with new construction materials, such as high performance concrete and fiber-reinforced composites was recommended. <b>Smart Bridges</b> It was found that nondestructive (NDT) methods enable fast, inexpensive and continuous monitoring of reinforcement condition. However, determination of the extent of corrosion is complex and may lead to misinterpretation of results, and to avoid this it was recommended that several NDT methods be combined or used in tandem, for robust analysis and conclusion about corrosion of reinforcement steel.					
17. Key Words Bridge, fenders, life cycle cost, precast, prefabricated, smart bridges, nondestructive testing, sensors, gauges			18. Distribution Statement		
19. Security Classif. (of this report) <b>Unclassified</b>		20. Security Classif. (of this page) <b>Unclassified</b>		21. No of Pages <b>250</b>	22. Price

## ACKNOWLEDGEMENTS

This report was prepared as the final part of the technology transfer research study on NJDOT's research problem statements 2001-05,06,07, for three separate bridge related areas, namely, **Energy Absorbing Fender Systems**, **Precast/Prefabricated Bridge Deck Systems** and **Smart Bridges**. The investigators greatly appreciate the New Jersey Department of Transportation and Federal Highway Administration – through the Region 2 University Transportation Research Center -- for their initiatives and support on this project. The Principal Investigators also recognize the following for their contributions to collecting and organizing information from various sources for this project:

- Prof. Michel Ghosn, Ph.D. (CCNY) – energy absorbing fender systems and smart bridges.
- Prof. Kolluru Subramaniam, Ph.D. (CCNY) -- smart bridges.
- Mr. Salutari J.M. Meja, M.Eng. (CCNY) – energy absorbing fender systems.
- Mr. Brian Quinlan, M.S. (UIC) – precast/prefabricated bridge deck systems.

The assistance of undergraduate research assistants, David Babb and Yolanda Rose (CCNY), in searching out product and vendor sources is also acknowledged. Salutari J.M. Meja also rates special mention for his yeoman assistance in developing the comparative life cycle cost example for fender systems, and in organization and presentation for the Final Report and Tech Briefs. Finally, the consultative advice on marine fendering from John McDonald, Jr., President of Skye Corporation in Pennsylvania, is acknowledged with much appreciation.

# TABLE OF CONTENTS

	<u>Page</u>
<b>SUMMARY.....</b>	<b>12</b>
<b>INTRODUCTION.....</b>	<b>12</b>
<b>PART A: ENERGY ABSORBING FENDER SYSTEMS.....</b>	<b>13</b>
Identified State-of-the-Art Fender Systems Currently in Use.....	13
Design Selection .....	14
<b>PART B: PRE-CAST or PREFABRICATED BRIDGE DECK SYSTEMS .....</b>	<b>20</b>
Pre-Cast Bridge Deck Systems Types Manufactured in NJ & Other States .....	20
Cost Comparisons .....	20
Life Cycle Cost Analysis .....	20
Recommendation.....	21
<b>PART C: SMART BRIDGES.....</b>	<b>32</b>
Smart Bridge Installations.....	32
Weigh-in-Motion Technology (WIM) .....	35
Strengths and Weaknesses of Each System.....	36
Recommendations to Improve the Systems Installed .....	36
<b>PART A: ENERGY ABSORBING FENDER SYSTEMS.....</b>	<b>38</b>
<b>INTRODUCTION.....</b>	<b>38</b>
Background Statement.....	38
<b>LITERATURE SURVEY.....</b>	<b>40</b>
Bridge Pier Collisions Survey.....	40
<u>Pier Protection</u> .....	42
<u>Available Fender Systems</u> .....	44
<u>Fender System Selection</u> .....	49

<b><u>Fender Purchase Considerations</u></b> .....	<b>49</b>
<b>Vendor and Installation Survey</b> .....	<b>50</b>
<b><u>SEAPILE® &amp; SEATIMBER® Composite Marine Products</u></b> .....	<b>50</b>
<b><u>Promar, LLC</u></b> .....	<b>51</b>
<b><u>Maritime International, Inc.</u></b> .....	<b>52</b>
<b><u>Urethane Technologies, Inc.</u></b> .....	<b>54</b>
<b><u>Viking Fender</u></b> .....	<b>54</b>
<b><u>Svedala/Trellex</u></b> .....	<b>56</b>
<b><u>Ultra Poly, Inc.</u></b> .....	<b>57</b>
<b><u>Schrader Co.</u></b> .....	<b>58</b>
<b>IDENTIFIED STATE-OF-THE-ART FENDER SYSTEMS</b> .....	<b>60</b>
<b>Cellular Sheet Pile Dolphin and Fenders</b> .....	<b>60</b>
<b>Donut Monopile Fender Systems</b> .....	<b>61</b>
<b>Composite Pile, Fender, and Dolphin Systems</b> .....	<b>62</b>
<b>RECOMMENDED BRIDGE PIER PROTECTION SYSTEM</b> .....	<b>67</b>
<b>System Description</b> .....	<b>67</b>
<b><u>Donut Monopile Dolphins</u></b> .....	<b>67</b>
<b><u>Composite Pile, Fender and Dolphin Systems</u></b> .....	<b>67</b>
<b>DESIGN PROCEDURES</b> .....	<b>74</b>
<b>Design Vessel Collision Forces</b> .....	<b>74</b>
<b>Summary</b> .....	<b>82</b>
<b>Design Example (Appendix 2)</b> .....	<b>83</b>
<b>LIFE CYCLE COST ANALYSIS</b> .....	<b>86</b>
<b>LCCA Spreadsheets for Fender System Alternatives</b> .....	<b>86</b>
<b>DISCUSSIONS ON THE RECOMMENDED SYSTEM</b> <b>88</b>	
<b>Life Cycle Cost</b> .....	<b>88</b>
<b>Energy Absorption Capabilities</b> .....	<b>89</b>
<b>Other Benefits</b> .....	<b>89</b>

<b>RECOMMENDATIONS.....</b>	<b>90</b>
<b>REFERENCES.....</b>	<b>92</b>
<b>APPENDIX A.....</b>	<b>94</b>
<b>Appendix A1: Bridge Pier Collision Forces Design – An Example.....</b>	<b>94</b>
<u>Design Data and Specifications</u> .....	94
<u>Equivalent Static Impact Load Calculations</u> .....	94
<u>Flotilla Frequency Distribution</u> .....	95
<u>Equivalent Static Barge Impact Load Frequencies</u> .....	96
<u>Design Barge Selection</u> .....	96
<u>Flotilla Velocity</u> .....	98
<u>Probability of Aberrancy</u> .....	98
<u>Design Barge Acceptance Criteria Calculations</u> .....	98
 <b>PART B: PRECAST OR PREFABRICATED BRIDGE DECK SYSTEMS.....</b>	 <b>105</b>
<b>INTRODUCTION.....</b>	<b>105</b>
<b>Pre-Cast Bridge Superstructures .....</b>	<b>105</b>
<b>Pre-Cast Bridge Decks .....</b>	<b>107</b>
<b>PERFORMANCE HISTORY.....</b>	<b>109</b>
<b>Total Superstructure.....</b>	<b>109</b>
<b>Segmental Bridges .....</b>	<b>110</b>
<b>Partial and Full Depth Pre-Cast Bridge Deck Panels .....</b>	<b>112</b>
<b>COST EFFICIENCY OF PRECAST BRIDGE DECK SYSTEMS.....</b>	<b>117</b>
<b>Acosta Bridge.....</b>	<b>119</b>
<b>Wando River Bridge.....</b>	<b>119</b>
<b>INNOVATIONS IN DESIGN AND CONSTRUCTION.....</b>	<b>120</b>
<b>High Performance Concrete.....</b>	<b>120</b>
<b>Fiber Reinforced Polymers .....</b>	<b>121</b>

Precast Through-Girder Bridges .....	122
<b>DISCUSSION AND RECOMMENDATIONS.....</b>	<b>123</b>
<b>REFERENCES.....</b>	<b>124</b>
<b>BIBLIOGRAPHY.....</b>	<b>127</b>
<b>APPENDIX B.....</b>	<b>132</b>
Appendix B1: American Segmental Bridge Institute Cost Data.....	132
Appendix B2: Listing of Certified Precasters in the USA.....	141
PCI Certification Categories.....	142
Appendix B3: Innovative Projects – Location and Description .....	146
<b>PART C: SMART BRIDGES.....</b>	<b>163</b>
<b>INTRODUCTION.....</b>	<b>163</b>
Background .....	165
<b>BRIDGE CONDITION MONITORING – CURRENT PRACTICE AND EMERGING ISSUES.....</b>	<b>166</b>
Corrosion Monitoring .....	167
<u>Existing Instrumentation and Uses</u> .....	167
Monitoring In-Service Corrosion – Methods and Techniques .....	171
<u>Passive Measurement Systems</u> .....	171
<u>Corrosion Macrocell Current Measurement</u> .....	174
<u>Electrochemical Noise</u> .....	176
<u>Polarization Measurements</u> .....	176
<u>Scanning Reference Electrode Method (SRET)</u> .....	181
<u>Nonelectrochemical Methods</u> .....	181
<u>Current Developments</u> .....	181
Monitoring Strains and Cracks .....	182
<u>Vibrating Wire Strain Gauge</u> .....	183
<u>Crack Meter</u> .....	183
<u>Embedment Strain Gauge</u> .....	183
<u>Beam Sensor</u> .....	184
<u>Multipoint Liquid Level System</u> .....	184



<u>Direct and Inverted Pendulum</u> .....	185
<u>Fiber Optic Sensor Types</u> .....	185
<u>Instrumentation of Fiber Optic Sensors (a few case studies)</u> .....	188
<u>Installing Fiber Optic Sensors in Civil Engineering Structures</u> .....	189
<b>WEIGH-IN-MOTION TECHNOLOGY</b> .....	189
Overview .....	189
Existing WIM Systems .....	190
<u>Bending Plates</u> .....	191
<u>Capacitive Mats</u> .....	192
<u>Piezoelectric, Quartz and Fiber-Optic Cables</u> .....	193
<u>Load Cells</u> .....	194
<u>Bridge WIM Systems</u> .....	195
WIM System Selection and Accuracy .....	196
<u>Quartz cables</u> .....	197
<u>B-WIM</u> .....	197
Application of WIM Technology & Smart Bridges to Bridge Rating .....	198
<b>IMPLEMENTATION OF SMART BRIDGE RESPONSE DATA IN BRIDGE LOAD RATING PROCESS</b> .....	200
Bridge Loads and Behavior .....	200
Member Capacity .....	201
<b>CONCLUSION AND RECOMMENDATIONS</b> .....	201
<b>REFERENCES</b> .....	202
<b>APPENDIX C: SENSOR EQUIPMENT</b> .....	205
Appendix C1: Embedded Sensors .....	205
<u>Appendix C1.1: Standard Reference Half-Cell by Cescor – Embeddable in Concrete</u> .....	205
<u>Appendix C1.2: Embedded Reference Half-Cell -- ERE 20 Probes</u> .....	208
<u>Appendix C1.3: Embeddable pH Sensor by Protector Group, Norway</u> .....	213
<u>Appendix C1.4: Embeddable Sensor for MacroCell Measurements and Data Logger</u> .....	214
<u>Appendix C1.5: Embedded Reference Half-Cell -- Corrosometer 650C Concrete Probe and CK-3 Datalogger</u> .....	218
<u>Appendix C1.6: An Embedded Linear Polarization Resistance Probe - Model 800/800T Corratr Concrete Probe</u> .....	221

<b><u>Appendix C1.7: Embedded Instrumentation for Linear Polarization Resistance, Open Circuit potential, and Chloride Ion Concentration – EC1 Probe</u></b> .....	224
<b><u>Appendix C1.8: Embeddable Reference Electrode – V-2000 Silver/Silver Chloride Electrode</u></b> .....	230
<b><u>Appendix C1.9: Permanent Embedded Electrode (Model CB)</u></b> .....	236
<b><u>Appendix C1.10: Rebar Probes for Polarization Measurement</u></b> .....	238
<b>Appendix C2: Gauges</b> .....	239
<b><u>Appendix C2.1: Geonor P-280W Weldable Vibrating Wire Strain Gauge for Reliable Monitoring of Strain in Steel and Concrete</u></b> .....	239
<b><u>Appendix C2.2: Geonor P-270 Extensometers for Reliable Monitoring of Crack and Joint Displacements</u></b> .....	241
<b><u>Appendix C2.3: Geonor Vibrating Wire P-600 Uniaxial Inclinator for Structures and Foundations</u></b> .....	243
<b><u>Appendix C2.4: The SOFO System – Single Deformation System</u></b> .....	245
<b><u>Appendix C2.5: SM 2001 Structure Monitoring System</u></b> .....	247

## LIST OF FIGURES

	<u>Page</u>
Figure S1. Schematic of Recommended Energy Absorbing Pier Fender System.	19
Figure A1. I-40 Bridge, Arkansas River .....	41
Figure A2. Available Fender Systems .....	44
Figure A3. Seapile & SeaTimber Marine Composite .....	50
Figure A4. ProMar Donut Type Monopile Fender .....	52
Figure A5. Marine Plastic Fenders .....	53
Figure A6. UHMW Marine Plastic Material Panel Facing.....	54
Figure A7. Urethane Products.....	55
Figure A8. Viking Fenders .....	55
Figure A9. Svedala/Trellex Fender Products .....	56
Figure A10. 145th St Bridge, New York, NY .....	57
Figure A11. 1st Avenue Bridge South, Seattle, WA.....	57
Figure A12. Tappan Zee Bridge, New York, NY .....	58
Figure A13. Schrader Co. Foam Filled Fenders & Plastic Pilings .....	58
Figure A14. Schuyler Model 114 Batter Block Fender .....	59
Figure A15. Schuyler Rubber’s Laminated Rubber Fenders .....	60
Figure A16. Casco Bay Bridge State-of-the Art Fender System .....	61
Figure A17. Floating Donut Fender at New York Port.....	62
Figure A18. Pier End at Lewis, DE Ferry .....	63
Figure A19. Hardcore Composite Fender Panel .....	63
Figure A20. Hardcore Composite Panel Facing.....	64
Figure A21. Concrete-Filled Fiberglass Tubular Piling .....	69
Figure A22. Three-Point Bending Test .....	70

Figure A23. Load-Deflection Curve for Fiberglass Piling .....	71
Figure A24. Composite Piling Applications .....	73
Figure A25. Distribution Function for Vessel Collision Forces.....	79
Figure A26. Probability of Vehicle Collision Model .....	81
Figure A27. Cumulative Distribution Function for Ship Collision.....	83
Figure A28. Spreadsheet for LCCA for Fender Systems .....	87
Figure A29. Recommended Fender System (Conceptual Diagram) .....	91
Figure A30. Bridge Over the Ohio River at Maysville.....	94
Figure A31. Dimensions for Geometric Probability Calculations, Maysville Section of Ohio River.....	99
Figure A32. A Dolphin of Composite Piles with Stay-in-Place Formwork.....	103
Figure A33. Installation of a Composite Monopile at Cape May, New Jersey .....	104
Figure B1. Full Depth Concrete Bridge Deck Panels .....	108
Figure B2. Construction of a Segmental Bridge.....	110
Figure B3. Segmental Components (Post-Tensioning Ducts Visible).....	111
Figure B4. Bayview Bridge, Quincy, Illinois.....	114
The next state visited by the inspection team was Connecticut, where an inspection was performed on the Waterbury Bridge, which is maintained by the Connecticut Department of Transportation. The six span, 700-foot long bridge was originally constructed in 1965 and reconstructed in 1989. The 27.5 foot wide deck was replaced with full width precast concrete panels that are 8 feet long and 8 inches thick. The deck was topped with a 2 ½ - inch bituminous wearing surface. The panel-to-girder shear connections were made with shear studs and pockets spaced at 2-inch intervals. Each shear pockets contains three 7/8 -inch shear studs. The transverse joints between panels are female-to-female type shear keys that are filled with high strength, non-shrink grout -- (see Figure B5). <sup>(36)</sup> .....	115
Figure B5. Typical Female-to-Female Shear Key.....	115
Figure B6. William Preston Jr. Memorial Bridge over the Chesapeake Bay .....	116
Figure B7. Stay-in-Place Bridge Deck Forms Supported by U-Beams .....	118
Figure B8. Through Girder Bridge (Sedley Bridge, Indiana) .....	123
Figure C1. Monitoring Chlorides for Cathodic Protection .....	170
Figure C2. Schematic Illustration of Occurrence of Corrosion in Cracked and Un- Cracked Concrete .....	170
Figure C3. Principle of the Half-Cell Method.....	171
Figure C4. MMO Ti Probe.....	173
Figure C6. Wire Sensor.....	174
Figure C7. Schiessel Probe .....	175
Figure C8. Corrowatch Probe.....	175
Figure C9. FORCE Probe .....	176
Figure C10. Gecor 6 .....	177
Figure C11. MS 4500 Polarization Device.....	178
Figure C12. C-Probe Type CP 100.....	178
Figure C13. CORROATER.....	179
Figure C14. Minisensor.....	179
Figure C15. The GalvaPulse Device.....	180

Figure C16. Schematic of the Psuedo-Reference Electrode Produced by Cescor .....	205
Figure C17. Photograph of the Embedded Reference Electrode Produced by ERE .....	208
Figure C18. Installation of Camur CorrRate Sensors.....	211
Figure C19. Embeddable Corrowatch – Macro-Cell for Registering the Initiation of Corrosion .....	214
Figure C20. Embedded CorroWatch .....	215
Figure C21. Corrolog Datalogger .....	216
Figure C22. Photograph of the 650C Corrosometer Concrete Probe .....	218
Figure C23. CK-3 Model .....	219
Figure C24. CK-4 Model .....	220
Figure C25. Embeddable LPR Probe (Model 800/800T Corratr Probe) .....	221
Figure C26. Remote data Collection System for Corratr Probe .....	222
Figure C27. CORRDATA® Mate: Portable, Handheld Instrument Used to Collect and Transfer Corrosion Data from CORROSOMETER® Probes .....	223
Figure C28. EC1 Probe.....	224
Figure C29. Model ECI-1 Embedded Corrosion Instrument .....	226
Figure C30. Schematic of ECI-1 Data Collection, Retrieval and Transmission System .....	228
Figure C31. V-2000 Reference Electrode.....	230
Figure C32. Manual or Automatic Monitoring with the V2000 .....	231
Figure C33. Monitoring Techniques in New and Existing Construction with the V2000.....	232
Figure C34. Permanent Embedded Electrode (Model CB).....	236
Figure C35. Extended Life Reference for Concrete (Model CX01) .....	237
Figure C36. Polarization Probe (Model CP-REB-SWnnn) .....	238
Figure C37. Geonor P-280W Installation .....	239
Figure C38. Geonor P-270 Installation .....	241
Figure C39. Schematic of Geonor P-600 .....	243
Figure C40. SOFO System Setup.....	245
Figure C41. Operating Principle of the SOFO Sensor.....	246

### LIST OF TABLES

	<u>Page</u>
Table S1. Existing Fender Systems .....	15
Table S2. Energy Absorbing Fender Systems Currently in Use .....	18
Table S3. Existing Precast Bridge Deck Systems .....	22

<b>Table S4. Identified Pre-Cast or Prefabricated Bridge Deck Systems Types in New Jersey and Other States .....</b>	<b>24</b>
<b>Table S5. Location and Description of the Identified Prefabricated Bridge Elements and Systems for Innovative Projects.....</b>	<b>28</b>
<b>Table S6. History of Performance .....</b>	<b>30</b>
<b>Table S7. Unit Costs for Segmental Bridges with Precast Decks .....</b>	<b>31</b>
<b>Table S8. Unit Costs for Segmental Bridges with Cast-in- Place Decks .....</b>	<b>31</b>
<b>Table S9. List of Smart Bridge Installations .....</b>	<b>32</b>
<b>Table S10. Smart Bridge Instrumentation for Corrosion .....</b>	<b>33</b>
<b>Table S11. Smart Bridge Instrumentation for Displacement/Strain .....</b>	<b>34</b>
<b>Table S12. Smart Bridge Instrumentation for Cracking .....</b>	<b>34</b>
<b>Table S13. Summary of WIM System Accuracy.....</b>	<b>35</b>
<b>Table S14. Estimated Average Annual Costs for Maintaining a Pavement-Based WIM System .....</b>	<b>36</b>
<b>Table S15. Strengths and Weaknesses of Smart Bridge Systems.....</b>	<b>37</b>
<b>Table A1. Major Ship Collisions with Bridges .....</b>	<b>42</b>
<b>Table A2. Available Fender Systems .....</b>	<b>45</b>
<b>Table A3. List of Fender Vendors and Their Contacts .....</b>	<b>65</b>
<b>Table A4. Performance Ratings for Energy Absorption Products .....</b>	<b>66</b>
<b>Table A5. Performance Ratings for Composite Piling .....</b>	<b>66</b>
<b>Table A6. Standard Composite Tubular Piling .....</b>	<b>69</b>
<b>Table A7. Flexural Data for Fiberglass Tubular Piling .....</b>	<b>71</b>
<b>Table A8. Composite Pile Manufacturers.....</b>	<b>85</b>
<b>Table A9. Results of LCCA for Generic Bridge Pier Fender Systems .....</b>	<b>87</b>
<b>Table A10: Equivalent Static Load Calculations-Maysville Bridge East Tower Pier .....</b>	<b>95</b>
<b>Table A11. Flotilla Frequency Distribution for Maysville Bridge.....</b>	<b>96</b>
<b>Table A12. Equivalent Static Barge Impact Load Frequencies (ESBILF) for West and East Pier Fenders for Maysville Bridge .....</b>	<b>97</b>
<b>Table A13. Typical Barge Size Dimensions and Capacities .....</b>	<b>97</b>
<b>Table A14. Annual Frequency (AF) of Collapse for East Pier with <math>H_p=31.89MN</math> .</b>	<b>100</b>
<b>Table A15. Annual Frequency of Collapse for West Pier with <math>H_p=31.89MN</math> .....</b>	<b>101</b>
<b>Table B1. Unit Costs for Segmental Bridges with Cast-In-Place Decks .....</b>	<b>119</b>
<b>Table B2. Unit Costs for Segmental Bridges with Precast Decks.....</b>	<b>119</b>
<b>Table C1. Interpretation of Corrosion Potential Measurements.....</b>	<b>172</b>
<b>Table C2: Summary of WIM System Accuracy .....</b>	<b>197</b>
<b>Table C3: Estimated Average Annual Cost of Maintaining a Pavement-Based WIM System .....</b>	<b>197</b>
<b>Table C4: Estimated Initial Cost per Lane for Pavement-Based WIM Systems ...</b>	<b>198</b>

# SUMMARY

## INTRODUCTION

This study was a three-part research project with the following objectives:

### Part A: Energy Absorbing Fender Systems

- (1) Identify existing technology, which has been used for bridge fender protective systems by other states or countries.
- (2) Identify State of the Art Systems that are of the Energy Absorbing/Impact deflecting variety that are either currently in use or commercially available. Ascertain that the State of the Art Systems conform to the AASHTO Design Guide Specification Commentary for Vessel Collision Design of Highway Bridges (Volume I Final).
- (3) Rate the designs based on cost benefit criteria from best to worst

### Part B: Pre-Cast or Prefabricated Bridge Deck Systems

- (1) Identify all pre-cast or prefabricated bridge deck system types manufactured in NJ & other states.
- (2) Provide a Location and History of Performance of the Identified Pre-cast or Prefabricated Bridge Deck Systems.
- (3) Provide a cost comparison of these systems versus cast-in-place systems.
- (4) Provide a life cycle cost analysis using these systems.

### Part C: Smart Bridges

- (1) Compile a list of all Smart Bridge installations that have been constructed throughout the United States and Canada along with their types and locations.
- (2) Ascertain strengths and weaknesses of each system installed and prepare a list detailing the particulars.
- (3) Provide recommendations for improvements to systems installed.

Following are the summaries and recommendations for each part of the study.

## **PART A: ENERGY ABSORBING FENDER SYSTEMS**

The existing technology, which has been used for bridge fender protective systems by other states or countries, was identified and grouped into six main categories as:

- Pile supported
- Retractable
- Rubber
- Gravity
- Hydraulic/pneumatic
- Floating systems

Descriptions of each are as summarized in Table S1 below, with their advantages and disadvantages.

### **Identified State-of-the-Art Fender Systems Currently in Use**

Energy absorbing fender systems that are commercially available were identified, in Table S2 below, along with three state-of -the-art fender systems currently in use as:

#### **Cellular Sheet Pile Dolphin and Fenders**

A pier protection system consisting of cellular sheet pile dolphin and fenders to demarcate the channel can be designed to prevent, or to minimize damage to the bridge piers due to vessel impact. Such a system was able to absorb the impact and prevent damage to both bridge pier and vessel in May 2002, when a 685-foot oil tanker transporting 11.3 million gallons of fuel struck the Casco Bay Bridge in Portland Maine.

#### **Donut Monopole Fender Systems**

A donut fender is a foam-filled fender, designed to be slipped over a stationary monopole. Such a system has been observed in New York port standing sentry for the pier it is protecting for some four years.

#### **Composite Pile, Fender, and Dolphin Systems**

Composite pile, fender and dolphin systems are custom designed for each situation. Fenders are secured to the outside of the composite pile to increase the energy absorption/deflection capabilities. Dolphins are used to deflect ship/barge as they negotiate narrow waterways or hairpin turns. An example of such a system was constructed by hardcore composites for pier ends at Lewes, Delaware Ferry on July 17, 1997.

## Design Selection

To select among various competing fender system design alternatives, life cycle cost analysis was performed for six alternatives, based on the use of materials with different properties and costs, as follows:

- Basic system (no fender).
- Steel fender system.
- Timber fender system.
- Concrete fender system.
- Rubber fender systems (rubber in compression /in-shear).
- Composite fender systems (hardcore composites, UHMW fender panels).

The results indicated that Composite Fender Systems have the lowest life cycle cost.

## Recommendations

Based on the life cycle cost analysis, a protection system composed of **“Hardcore Composite Pile Dolphins, composite Tubular Piles with Stay-in-place Formwork surrounded by Composite Ultra High Molecular Weight Fender Panels”** is recommended as the state-of-the-art system for New Jersey Department of Transportation. This system is similar to the one used at Casco Bay Bridge but with additions/modifications to facilitate the design of a 100% energy absorbing system. The state-of-the-art system at Casco Bay Bridge in Portland Maine was able to absorb the impact and prevent damage to the bridge pier, bridge, and the vessel, in May 2002, when a 685-foot oil tanker transporting 11.3 million gallons of fuel struck the bridge fender system. Only about \$1 million was needed to repair the fender system after the impact. This system, which cost about \$7million, was designed to absorb the energy of a 50,000-dwt vessel traveling at 5 knots and striking the fenders at a 15° angle (an equivalent of 46.25 MN lateral load).

A schematic of the recommended system is shown in Figure S1. Details of the design concept are to be found in Part A of this report.



**Table S1. Existing Fender Systems**

<b>TYPES</b>	<b>DESCRIPTION</b>	<b>ADVANTAGE</b>	<b>DISADVANTAGE</b>
<b>A. STD PILE-FENDER SYSTEM</b>	Employs piles driven to the bottom of the sea. Energy on a fender pile is absorbed by deflection and the limited compression of the pile. Energy absorption capacity depends on the pile and is determined on the basis of internal strain-energy characteristics.		
1. Timber piles	Consists of timber members. A contact frame is formed that distributes impact loads.	Low initial cost and abundant timber piles.	Limited energy-absorption susceptibility to mechanical /biological damage
2. Steel piles	Used in water depth greater than 40 feet.	Strength and feasibility for difficult seafloor conditions.	Vulnerability to corrosion and high initial cost.
3. Concrete piles	Pre-stressed concrete piles with rubber buffers at deck level have been used.	Resists natural and biological deterioration.	Limited strain-energy capacity and corrosion of steel through cracks.
4. Composite piles	Composite pile is a cylindrical shell fabricated of high-strength fiber-reinforced composite materials.	High-energy absorption resists natural and biological deterioration.	High initial cost.
<b>B. RETRACTABLE FENDER SYSTEMS</b>	A retractable fender system consists of vertical-contact posts connected by rows of wales and chocks. The fender retracts under impact, thus absorbing energy by action of gravity and friction. Energy- absorption capacity depends directly on the effective weights, the angle of inclination of the supporting brackets and the maximum amount of retraction of the system.	Negligible effects of bio-deterioration on energy absorption capacity. Low maintenance cost. Minimum equipment requirements.	Vulnerability to corrosion of the supporting brackets. High initial cost if used on open type piers.

TYPES	DESCRIPTION	ADVANTAGE	DISADVANTAGE
<b>C. RUBBER FENDER SYSTEMS</b>	Rubber fender consist of two major types, rubber-in- compression and rubber-in-shear.		
1. Rubber-in-compression	Consists of a series of cylindrical rubber or rectangular tubes installed behind standard fender piles. Energy absorption is achieved by compression of the rubber. Absorption capacity depends on the size of the buffer and on maximum deflection. The energy-absorption capacity can be varied by using the tubes in single or double layers, or by varying tube size.	Simplicity and adaptability plus effectiveness at reasonable cost.	High concentrated loading may result. Initial cost is higher than standard pile system without resilient units.
2. Rubber-in-shear	Consists of a series of rubber pads bonded between steel plates to form a series of rubber sandwiches mounted firmly as buffers between a pile-fender system and a pier. Two types of mounting units are available: standard unit or overload unit, which is capable of absorbing 100% more energy.	Capability of cushioning impact from lateral and vertical directions. High energy absorption capacity. Favorable initial cost.	Too stiff for small vessels. Steel plates subject to corrosion. Problem with bond between steel plate and rubber.
3. Lord flexible	Consists of an arch-shaped rubber block bonded between two end steel plates. It can be installed on open or bulk head-type piers, dolphins, or incorporated with standard pile or hung fender systems. Impact energy is absorbed by bending (buckling) and compression of the arch-shaped column.	High energy-absorption and low terminal-load characteristics.	Bond between steel plates and rubber plus possible fatigue problems.
4. Rubber-in-torsion	Rubber and steel combination fabricated in cone-shaped compact bumper form, molded into a specially cast steel frame and bonded to the steel. It absorbs energy by torsion, compression,	Capable of resisting the impact load from all directions	Bond between steel casting and rubber and fatigue problems

TYPES	DESCRIPTION	ADVANTAGE	DISADVANTAGE
	shear and tension, but most energy is absorbed by compression.		
5. Pneumatic	Pneumatic fenders are pressurized, airtight rubber devices designed to absorb impact energy by the compression of air inside a rubber envelope. Energy-absorption capacity and resistance load depend on the size and number of tires used and on the initial air pressure when inflated.	Suitable for both berthed and moored ships.	High maintenance cost.
<b>D.GRAVITY-TYPE FENDER SYSTEMS</b>	Gravity fenders are normally made of concrete blocks and are suspended from heavily constructed wharf decks. Impact energy is absorbed by moving and lifting the heavy concrete blocks.	High energy-absorption.	Heavy equipment requirement. Initial and maintenance costs are high.
<b>E.HYDRAULIC/ PNEUMATIC FENDER SYSTEMS</b>			
1.Dashpot hydraulic	Consists of a cylinder full of oil or other fluid so arranged that when a plunger is depressed by impact, the fluid is displaced through a non-variable or variable orifice into a reservoir at higher elevation. Suitable where severe wind, wave, swell, and current conditions exist.	Favorable energy-absorption characteristics.	High initial and maintenance costs.
2. Hydro-pneumatic floating fender	This is a system of floating rubber envelopes filled with water and air, which absorbs energy by viscous resistance or by air compression.	Favorable energy-absorption characteristics	High initial and maintenance costs.
<b>F. FLOATING FENDER SYSTEMS</b>	Consist of floating logs, which ride up and down against the timber breasting face.	Easy application. High water depths.	Low energy absorption.

**Table S2. Energy Absorbing Fender Systems Currently in Use**

<b>Current Barrier Systems / Type / References</b>	<b>States (US)/ Countries</b>	<b>Intended Usage</b>	<b>Photo/Sketch (Y/N)</b>
Plastic Pilings Timber Seaward International <a href="http://www.seaward.com">http://www.seaward.com</a>	Washington Algeria, Hong Kong, Korea, Barbados, Sweden		Y
Energy Absorbing Dolphin Pier System Hardcore Composites <a href="http://www.hardcorecomposites.com/">http://www.hardcorecomposites.com/</a>	Delaware		N
Marine Fenders UHMW-PE Marine Plastic Maritime International, Inc. <a href="http://www.maritime-international.com">http://www.maritime-international.com</a>			Y
Foam Filled Fenders Donut Type Fender Promar, LLC <a href="http://www.promarww.com/">http://www.promarww.com/</a>			Y
Dock Fendering Urethane Technologies, Inc. <a href="http://www.utibuoy.com/">http://www.utibuoy.com/</a>			N
Unit Element Fendering System FENTEK <a href="http://www.worldyellowpages.com/hercules/">http://www.worldyellowpages.com/hercules/</a>	Australia, Singapore, United Kingdom, Germany		Y
“Softlite” Foam Ship and Pier Fenders Viking Fender <a href="http://www.vikingfender.com/">http://www.vikingfender.com/</a>	New Jersey	Hull Protection	Y
MV Fender Systems Svedala Trellex <a href="http://www.jhmenge.com/">http://www.jhmenge.com/</a>	Louisiana	Dock & Vessel Fendering	Y
UMHV Fenders Ultra Poly, Inc. <a href="http://www.ultrapoly.com/">http://www.ultrapoly.com/</a>	New York, Washington, Canada, Central & South America	Bridge Pier Protection	Y
Plastic Pilings Foam Filled Fenders Schrader Co. <a href="http://www.schraderco.com">http://www.schraderco.com</a>	California, Washington, Mexico	Pier Protection Ship Protection	Y
Laminated Rubber Fenders Schuyler Rubber Company <a href="http://www.schuylerrubber.com/offshorefenders.html">http://www.schuylerrubber.com/offshorefenders.html</a>	Washington	Pier & Dock Protection	Y

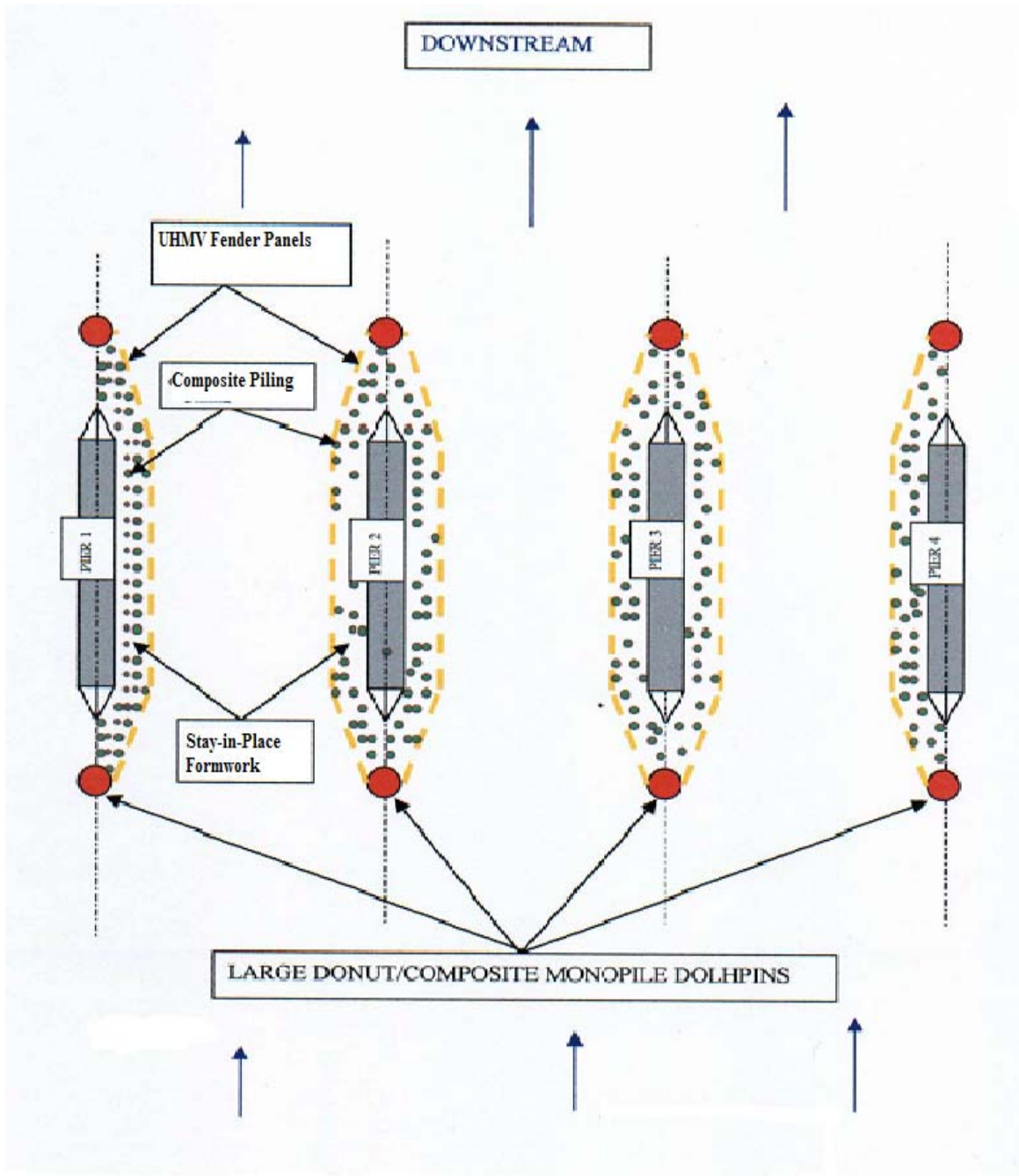

Figure S1. Schematic of Recommended Energy Absorbing Pier Fender System

## **PART B: PRE-CAST or PREFABRICATED BRIDGE DECK SYSTEMS**

Precast/prestressed bridge deck systems used in the United States and the United Kingdom were identified and grouped into two main categories as:

- 1) Total Precast Superstructures
- 2) Precast Bridge Deck Panels

Descriptions, advantages and disadvantages associated with each type of system are detailed in Table S3.

### **Pre-Cast Bridge Deck Systems Types Manufactured in NJ & Other States**

Pre-cast or prefabricated bridge deck system types manufactured in New Jersey and other states were identified, along with the manufacturers and their contacts. These are listed in Table S4.

### **Location and History of Performance/Description of the Identified Pre-Cast Bridge Deck Systems**

Two categories of pre-cast bridge decks were studied to determine their prevalence, performance, and cost efficiency and construction methods. The first category was the pre-cast superstructures (box beams, tee-beams and pre-cast segmental components), and the second category was the pre-cast bridge panel (partial or full depth). It was found that more than 50% of bridges built in the United States are classified as pre-stressed concrete bridge. Location and description of the identified prefabricated bridge elements and systems for innovative projects are listed in Table S5. Performance histories are summarized in Table S6.

### **Cost Comparisons**

Unit costs for some segmental bridge pre-cast deck projects and cast in place bridge deck projects were discounted at 4% and their average present worth compared. The results concluded that the cost of segmental bridge with pre-cast deck is about 40% less than the cost of segmental bridges with cast in place decks -- see Tables S7 and S8.

### **Life Cycle Cost Analysis**

There are many details that must be considered when performing a life cycle cost analysis, most of which are project specific. The Office of Applied Economics, National Institute of Standards and Technology has developed software to aid in the life cycle cost analysis of bridges called Bridge LCC. It is specifically designed to help engineers determine the cost effectiveness of alternative construction materials such as High Performance Concrete, Fiber Reinforced Polymers, etc., but is equally effective for use with conventional building materials.

A free version of this software can be downloaded at the following web address: [www.bfrl.nist.gov/bridgelcc/download.html](http://www.bfrl.nist.gov/bridgelcc/download.html). The methods used in Bridge LCC are based on the ASTM standard E-917 and a cost classification developed at the National Institute of Standards and Technology.

### **Recommendation**

Through this research, it has become evident that precast bridge decks have several advantages over those that are cast-in-place, including faster construction schedules, longer services lives and potentially greater cost efficiency. The use of precast bridge decks in conjunction with new construction materials such as High Performance Concrete and Fiber-Reinforced Composites is recommended.

**Table S3. Existing Precast Bridge Deck Systems**

TYPES	DESCRIPTION	ADVANTAGE	DISADVANTAGE
<b>A.TOTAL PRECAST SUPERSTRUCTURES</b>	Superstructures consisting of precast beams or girders that are cast with an integral deck. If specified, these units can be overlaid with an asphalt or concrete wearing surface to provide a smoother ride.		
1. T-Beams	Concrete beam sections that consist of deep webs and wide thin flanges. They are commonly manufactured in single, double and multiple T configurations.	Requires little, if any formwork for cast-in-place wearing surface. Single T span lengths up to 120'	Allowable span length of multiple T section is much shorter (approx 30'). Span length is limited by design, construction and transportation restraints.
2. Decked Bulb T-Beams	Concrete beam sections that consist of standard 5-10' wide top flange, 2' wide bottom flanges and variable depths. Top flanges are cast with normal strength concrete while the rest of the section is made of high strength concrete.	Available span lengths of up to 190' depending on transportation restraints.	More expensive than conventional T-beams due to high performance concrete.
3. Adjacent Box Beams	Concrete beam with rectangular sections that are manufactured with flange widths of 3 or 4 feet and variable depths. Beams are placed contiguously in transverse direction resulting in a ready-made deck.	Economical superstructure for span lengths up to 100'. Very low rate of structural deficiency according to the National Bridge Inventory.	Have had problems with cracking in the wearing surface and the grouted joints between beams due to lack of lateral continuity.
Internal prestressing tendons are very susceptible to corrosion if they are not constructed /grouted properly. Extensive testing for this type of corrosion in existing bridges has not yet been incorporated into standard bridge inspections.	Single or multi-cell box girders that are placed contiguously in the longitudinal direction with steel prestressing tendons that are post-tensioned through ducts in the girders to provide continuity.	Very effective in building bridges with horizontally curved alignments. Can be erected with minimal environmental impact as construction can proceed from on top of the bridge with equipment segments.	



TYPES	DESCRIPTION	ADVANTAGE	DISADVANTAGE
<b>B. PRECAST BRIDGE DECK PANELS</b>	Prefabricated concrete panels that are placed adjacent to one another and supported by beams or girders. These panels can make up a partial thickness of the bridge deck.		
1. Stay-in-place forms	Partial depth precast/prestressed concrete deck panels that are erected as formwork for a cast-in-place bridge deck. The concrete panels are left in place to act compositely with the cast-in-place portion of the deck.	Reduction in time and labor spent installing and removing timber formwork. Reduction in required thickness of cast-in-place portion of the deck.	Occasional problems of transverse and longitudinal reflective cracking in the cast-in-place wearing surface.
2. Full-Depth Deck Panels	Precast/prestressed concrete deck panels that are cast the entire thickness of the deck. These panels are placed adjacent to each other and supported by beams or girders. Often, a very thin wearing surface is cast over the panels.	Versatility; can be placed on steel rolled beams, plate girders or concrete girders. Faster construction schedules, resistance to corrosion.	Must be post-tensioned both longitudinally and transversely. Susceptible to leakage at joints.
3. NUDECK	An improved type of stay-in-place panel that was developed at the University of Nebraska-Lincoln. These partial depth concrete panels are cast the entire width of the bridge deck. Shear keys and reinforced pockets are used to connect panels in the longitudinal direction.	These panels offer both transverse and longitudinal continuity, which reduces reflective cracking in the wearing surface. Also, construction time is reduced as there are a smaller amount of panels to assemble.	Panels can be very large and awkward, making transportation to the site difficult.
4. FRP Deck Panels	Precast/ prestressed concrete deck panels that incorporate fiber reinforced polymers instead of steel to provide tension and prestressing reinforcement. Design and construction procedures are similar to those associated with conventional full depth deck panels.	Panels are very lightweight in comparison with conventional deck panels. Also, they are very resistant to corrosion which increases service life of the deck.	Panels are very expensive, costing about twice as much as conventional full depth panels. This technology has not yet been widely implemented and tested so there is little information on their field performance.

**Table S4. Identified Pre-Cast or Prefabricated Bridge Deck Systems Types in New Jersey and Other States**

<[www.nationalbridgeinventory.com](http://www.nationalbridgeinventory.com)>

System Type	Products	Manufacturer	Contacts
Precast Bridge products	Architectural Precast, box beams, Columns, Joists, Structural Wall Panels, Hollow Core Slabs, Single Tees, Double Tees	Lakelands Concrete Products, Inc. Lima, NY	(716) 624-1990
		<a href="#">Oldcastle Precast, Inc./dba Rotondo Precast</a> Telford, PA	(215) 257-8081
		Concrete Safety Systems Bethel, PA	(570) 933-4107
		Smith-Midland Corporation Midland, VA	(540) 439-3266
		Concrete Products of Western Washington, LLC Puyallup, WA	(253) 846-2774
		DiSanti Concrete Products Incorporated Howell, NJ	(732) 751-0900
Prestressed Miscellaneous Bridge Products	Piles, Box beams, Columns, Joists, Structural Wall Panels, Single Tees, Double Tees	Boykin Brothers, Inc./Louisiana Concrete Products Baton Rouge, LA	(225) 753-8722
		Oldcastle Precast, Inc./dba Chase Precast North Brookfield, MA	(508) 867-8312
		Atlantic Metrocast, Inc. LaPlata, MD	(301) 870-3289
		<a href="#">Concrete Precast Systems, Inc.</a> Chesapeake, VA	(757) 545-5215
		William E. Dailey, Inc. Shaftsbury, VT	(802) 442-4418
		<a href="#">Coreslab Structures (ARK) Inc.</a> Conway, AR	501) 329-3763
		The United Precasting Corporation Buena, NJ	(856) 697-3600
		<a href="#">J. Boccella &amp; Sons Concrete Products, Inc.</a> Sicklerville, NJ	(856) 767-4140
Prestressed Straight-Strand Bridge	Box beams, Columns, Joists, Structural Wall Panels, Single Tees, Double Tees	<a href="#">Concrete Building Systems, Inc.</a> Delmar, DE	(302) 846-3645

<b>System Type</b>	<b>Products</b>	<b>Manufacturer</b>	<b>Contacts</b>
Members	Wall Panels, Single Tees, Double Tees, Piles, Hollow Core Slabs	<a href="#">Coreslab Structures (TAMPA) Inc.</a> Tampa, FL	(813) 626-1141
		Grace Pacific Precast, Inc. Kapolei, HI	(808) 682-5761
		Illinois Concrete Company, Inc. Champaign, IL	(217) 352-4181
		<a href="#">St. Louis Prestress, Inc.</a> Glen Carbon, IL	(618) 656-8934
		<a href="#">Rinker Materials Corporation</a> Lafayette, IN	(765) 474-1411
		Hoosier Precast LLC Prestress Engineering Corporation Salem, IN	(812) 883-4665
		Shelby Precast Concrete Co. Shelby Township, MI	(586) 247-9045
		<a href="#">Rinker Materials Corporation</a> LaPlatte, NE	(402) 291-0733
		Newstress International, Inc. Epsom, NH	(603) 736-9348
		Precast Management Las Vegas, NV	(702) 433-2993
		<a href="#">Oldcastle Precast, Inc.</a> South Bethlehem Division South Bethlehem, NY	(518) 767-2269
		<a href="#">Oldcastle Precast, Inc./dba Spancrete Northeast</a> Manchester, NY	(716) 289-3530
		Marietta Structures Corporation Marietta, OH	(740) 373-2400
<a href="#">Rinker Materials Corp./Oklahoma City Prestress</a> Rinker Materials Oklahoma City, OK	(405) 672-2325		
Prestressed Straight-Strand Bridge Members (cont'd)	Box beams, Columns, Joists, Structural Wall Panels, Single Tees, Double Tees, Piles, Hollow Core Slabs	J & R Slaw, Inc. Lehigh, PA	(610) 852-2020
		Structural Concrete Products, LLC Richmond, VA	(804) 222-8111
		Oldcastle Precast, Inc./dba Rotondo Precast Fredericksburg, VA	(540) 898-6300

System Type	Products	Manufacturer	Contacts
		<a href="#">Concrete Precast Systems, Inc.</a> Chantilly, VA	(703) 327-4112
		Bayshore Concrete Products/Chesapeake, Inc. Chesapeake, VA	(757) 382-0547
		Carr Concrete Corporation Waverly, WV	(304) 464-4441
		Eastern Vault Company, Inc. Princeton, WV	
Prestressed Deflected-Strand Bridge Members	Architectural Precast, Box beams, Columns, Joists, Structural Wall Panels, Hollow Core Slabs, Single Tees, Double Tees Architectural Trim	Con-Force Structures Limited Alberta Region Calgary, AB	(403) 248-3171
		Precast Systems, Inc. Allentown, NJ	(609) 208-1987
		<a href="#">Sherman Prestressed Concrete</a> Pelham, AL	(205) 663-4681
		TPAC A Div. of Kiewit Western Co. Tucson, AZ	(520) 887-7820
		TPAC A Div. of Kiewit Western Co. Phoenix, AZ	(602) 262-1360
		Surespan Contracting LTD Duncan, BC	(250) 748-8888
		Con-Force Structures Limited Pacific Region Vancouver, BC	(604) 278-9766
		Pomeroy Corporation Perris, CA	(909) 657-6093
Prestressed Deflected-Strand Bridge Members	Architectural Precast, Box beams, Columns, Joists, Structural Wall Panels, Hollow Core Slabs, Single Tees, Double Tees Architectural Trim	Pomeroy Corporation Petaluma, CA	(707) 763-1918
		<a href="#">Coreslab Structures (L.A.) Inc.</a> Perris, CA	(909) 943-9119
		Con-Fab California Corporation Lathrop, CA	(209) 858-2521

System Type	Products	Manufacturer	Contacts
		Clark Pacific Fontana, CA	(909) 823-1433
		A. T. Curd Structures, Inc. Rialto, CA	(909) 357-0197
		Plum Creek Structures Littleton, CO	(303) 471-1569
		<a href="#">Stresscon Corporation</a> Colorado Springs, CO	(719) 390-5041
		<a href="#">Rocky Mountain Prestress, Inc.</a> Structural Plant Denver, CO	(303) 480-1111
		<a href="#">Blakeslee Prestress Inc.</a> Branford, CT	(203) 481-5306
		Standard Concrete Products, Inc. Tampa, FL	(813) 831-9520
		<a href="#">Tindall Corporation</a> Jonesboro Division Jonesboro, GA	(800) 849-6384

**Table S5. Location and Description of the Identified Prefabricated Bridge Elements and Systems for Innovative Projects**

< [www.nationalbridgeinventory.com](http://www.nationalbridgeinventory.com) >

<b>Project</b>	<b>Prefabricated Elements/Systems</b>	<b>Location</b>	<b>State</b>	<b>Completion Date</b>	<b>Advantage</b>	<b>Contacts</b>
Dead Run and Turkey Run Bridges	Decks (full-depth non-composite decks)	George Washington Memorial Parkway	VA	1998	Minimized traffic disruption	(703) 404-6233
Tappan Zee Bridge	Decks (exothermic deck panels)	Hudson River, about 13 miles north of New York City	NY		Rapid placement of the panels, durability of reinforced concrete	(518) 436-2700
I-45/Pierce Elevated	Bent caps; decks (precast bent caps; precast prestressed deck panels; precast prestressed I-beams )	Downtown Houston	TX	1997	Minimized traffic disruption	(713) 802-5435
Illinois Route 29 over Sugar Creek	Decks (full depth, full width, precast post-tensioned concrete deck panels, precast concrete New Jersey parapets)	1 mile east of Springfield, Sangamon County	IL	2001	Minimized traffic delays	(217) 785-2913
Keaiwa Stream Bridge	Decks (4-foot-wide by 11-inch-thick precast prestressed concrete deck planks)	Route 11 near Pahala	HI	2000	Minimized traffic disruption, minimized environmental disruption	(808) 692-7611
Lavaca Bay Causeway	Decks (girder/slab/diaphragm/ center median/curb/sidewalk/parapet walls precast and later prestressed as a single unit, precast monolithic beam)	Between Port Lavaca and Point Comfort, over the Lavaca Bay	TX	1961	Constructability	(361) 293-4300
Route 7 over Route 50	Decks (pre-cast lightweight deck panels)	Fairfax County	VA	1999	Minimized traffic disruption & equipment	(703) 383-2117
Route 57 over Wolf River	Bent caps; decks, precast bent caps; precast prestressed concrete stay-in-place deck forms; precast prestressed I beams; steel pipe piles	Fayette County	TN	1999	Minimized environmental disruption & traffic disruption	(615) 741-3351

<b>Project</b>	<b>Prefabricated Elements/Systems</b>	<b>Location</b>	<b>State</b>	<b>Completion Date</b>	<b>Advantage</b>	<b>Contacts</b>
SH 36 over Lake Belton	Bent caps; decks (precast bent caps; precast prestressed deck panels; precast prestressed U-beams)	Near Waco	TX	2004	Contractibility	(512) 416-2279
SH 66/ Lake Ray Hubbard	Bent caps; decks (precast bent caps; precast prestressed deck panels; precast prestressed I-beams)	Near Dallas	TX	2002	Work zone safety Minimized traffic disruption	(512) 416-2279
SH 249/Louetta Road Overpass	Total substructure systems; decks (precast pretensioned partial-depth deck panels, precast post-tensioned piers, pretensioned U-beams)	Houston	TX	1994	Minimized traffic disruption	(512) 416-2183
Spur Overpass over AT&SF Railroad	Decks (precast full-depth deck panels)	Downtown Lubbock	TX	1988	Minimized traffic disruption	(806) 745-4411
Troy-Menands Bridge	Decks (exodermic deck panels)	City of Troy and Albany	NY	1995	Minimized traffic disruption	(518) 473-0497
US 27 over Pitman Creek	Decks (full-depth deck panels, New Jersey barrier railing ) Location: Somerset	Somerset	KY	1993	Minimized traffic disruption	(502) 564-4560,
US 59 under Dunlavy, Hazard, Mandel and Woodhead Streets	Decks (precast prestressed deck panels)	Houston	TX	1995	Minimized traffic disruption and improved constructability	(713) 802-5235

**Table S6. History of Performance**

<b>Project</b>	<b>Location</b>	<b>Year completed</b>	<b>Performance history</b>
Bayview Bridge	Quincy, IL	1986	Minor debonding of wearing surface, otherwise panels and joints performing satisfactorily.
Seneca Bridge	LaSalle County, IL	1986	Random cracking in approach spans, leakage through joints between adjacent panels due to improper joint specification.
Waterbury Bridge	Connecticut	1989	Deck panels in good condition and performing properly, however minor cracks found in the cast-in-place end haunches.
William Preston Jr. Memorial Bridge	Chesapeake Bay (Maryland)	Original Construction 1952 (deck has since been replaced with precast panels, date unknown)	Several problems found with this bridge deck. Diagonal cracking found on both sides of deck due to lack of transverse prestressing strands in panels. Cast-in-place concrete wearing surface didn't bond above the joints between precast panels in one location. Substantial leakage through transverse joints between panels.
Amsterdam Interchange Bridge	Montgomery County, New York	1974 (Part of bridge deck was rehabilitated with precast panels, other part with cast-in-place concrete.)	Bridge deck has had broken slabs due to use of bolted shear connections (no longer in use by New York State Thruway Authority). Spalling, longitudinal and transverse cracking and joint leakage was observed, the cause of which was a lack of longitudinal post-tensioning.
Krumkill Road Bridge	Albany County, New York	N/A	Bridge deck has had problems with fracture and spalling along transverse joints between panels. Also joints are not tight, allowing regular leakage due to a lack of longitudinal post-tensioning.
Harriman Interchange Bridge	Orange County, New York	N/A	A lack of longitudinal post-tensioning has caused the deck to randomly crack and spall. Reflective cracks observed in the wearing surface above the transverse joints between precast panels.



**Table S7. Unit Costs for Segmental Bridges with Precast Decks**

Project Name	Owner	Year Constr.	Cost/Sq.ft. (\$), 0 yr	Analysis Year	Yrs. (n)	Int. Rate	Cost/Sq.ft PW (\$)
Wando River Bridge	SCDOT	1995	43.55	2003	8	4%	59.60
Bath-Woolwich	Maine DOT	1997	194.84	2003	6	4%	246.53
Sailboat Bridge	Oklahoma DOT	1998	82.33	2003	5	4%	100.17
Broadway	FDOT	1998	90.61	2003	5	4%	110.24
Hathaway Bridge Replacement	FDOT	2000	106.73	2003	3	4%	120.06
I-93/I-90 Interchange	Massachusetts	1996	166.67	2003	7	4%	219.33
I-25/I-40 Interchange	NMSHTD	2000	82.79	2003	3	4%	93.13
C019B1 N.Charles River	Mass. Hwy. Dept.	1997	147.89	2003	6	4%	187.13
<b>TOTAL</b>							<b>1136.18</b>
<b>AVERAGE</b>							<b>142.02</b>

**Table S8. Unit Costs for Segmental Bridges with Cast-in- Place Decks**

Project Name	Owner	Year Constr.	Cost/Sq. ft (\$), 0 yr	Analysis Year	Yrs. (n)	Int. Rate	Cost/Sq.ft PW (\$)
Acosta Bridge	FDOT	1990	\$176.95	2003	13	4%	294.63
Puyallup River Bridge	WSDOT	1994	\$129.95	2003	9	4%	184.96
Wabasha Street	City of St. Paul	1995	\$112.00	2003	8	4%	153.28
Putnam Street	Washington County	1998	\$167.49	2003	5	4%	203.78
I-895 Over James River	VDOT	1998	\$208.54	2003	5	4%	253.72
Creve Coeur P. Memorial	MHTC	1999	\$159.68	2003	4	4%	186.80
Memorial Causeway	FDOT	2001	\$112.16	2003	2	4%	121.31
SR 87 Arizona	AZDOT	1996	\$145.00	2003	7	4%	190.81
I-93 Viaducts and Ramps	Massachusetts	1998	\$152.00	2003	5	4%	184.93
<b>TOTAL</b>							<b>1774.23</b>
<b>AVERAGE</b>							<b>197.14</b>

## PART C: SMART BRIDGES

A “smart bridge” can be defined as a bridge that has the ability to monitor its structural behavior and other performance during construction as well as under service loads and maximum loading conditions. Smart bridges usually utilize different instruments to monitor various physical parameters under different weather and loading conditions. Four of the most important parameters of concern to engineers are:

- Corrosion/Temperature
- Stress/Pressure
- Displacement/Strain
- Cracking

Nondestructive methods are advantageous when compared to destructive methods because they enable a continuous monitoring of reinforcement condition and allow for measurements to be done at the level of the entire structure, and they have proven to be fast and inexpensive. On the other hand, determination of reinforcement steel corrosion with nondestructive methods is complex and may lead to wrong interpretation of results. This can be minimized by combining several nondestructive testing methods, before making any conclusion about reinforcement steel corrosion.

### Smart Bridge Installations

A list of smart bridge installations is presented in Table S9. In addition to location and

**Table S9. List of Smart Bridge Installations**

<b>Instrumentation currently in Use</b>	<b>States US/Countries</b>	<b>Intended Usage</b>
Cescor (Milan Italy) <a href="http://www.cescor.it">http://www.cescor.it</a>		Monitoring corrosion reinforced and pre-stressed concrete structures
Force Technology <a href="http://www.force.dk/ciad/">http://www.force.dk/ciad/</a>	Denmark, Sweden, Norway	Monitoring of the corrosion condition of reinforcement
CorrPro Companies Inc. <a href="http://www.corrpro.com">http://www.corrpro.com</a>		Measures the corrosion rate of steel reinforced concrete structures
Virginia Technologies Inc <a href="http://www.vatechnologies.com/eci.htm">http://www.vatechnologies.com/eci.htm</a>		Embeddable instrument capable of measuring parameters important to long term corrosion monitoring
Vetek systems Corporation <a href="http://www.veteksystems.com">http://www.veteksystems.com</a>	Iowa, Texas, Delaware	Monitoring for corrosion, and corrosion rate
Geonor <a href="http://www.geonor.com">http://www.geonor.com</a>		Embedded and surface mounted instrumentation for measuring strains, inclination and crack displacement
SOFO System <a href="http://www.smartec.ch">www.smartec.ch</a>		Monitoring strain in rebar or surface strain

**Table S10. Smart Bridge Instrumentation for Corrosion**

No	References	Smart Bridge Installation/ Type	Description	Primary Use	Proprietary Name	States
1	Cescor (Milan, Italy) <a href="http://www.cescor.it">http://www.cescor.it</a>	Permanent embeddable pseudo-reference electrode for corrosion monitoring	Monitoring system for reinforced and pre-stressed concrete structures		Cescor – MMO Ti Probe	
2	Force Technology <a href="http://www.force.dk/ciad/">http://www.force.dk/ciad/</a>	An embeddable reference electrode	Monitoring of the corrosion condition of reinforcement	Bridges, tunnels, docks and swimming pools	ERE 20	Denmark, Sweden, Norway
		Embeddable probe for corrosion rate monitoring	Monitoring corrosion rate continuously by using macrocell current measurements between anodically and cathodically acting steel surface areas	Tunnels, bridges, parking decks, etc	Corro Watch 1	
		Post mounted probe for corrosion rate monitoring	Monitoring corrosion rate by macrocell current measurements between anodically and cathodically acting steel surface areas	Tunnels, bridges, parking decks, etc.	Corro Watch 2	
		Datalogger	Collects and stores data from Corrowatch probes		Corro Log	
3	CorrPro Companies Inc. <a href="http://www.corrpro.com">http://www.corrpro.com</a>	Embedded probe for corrosion monitoring	Measures the corrosion rate of steel reinforced concrete structures.		650C Corrosometer Concrete Probe	
		Embedded probe for corrosion rate monitoring	Measures the instantaneous corrosion rate of reinforcing steel in concrete by the method of linear polarization resistance (LPR)		Corrater 800/800T concrete probes	
		Data logger	Portable handheld instrument used to collect and transfer corrosion data from CORROSOMETER® probes or CORRATER® probes		Corrdata Mate	
4	Virginia Technologies Inc <a href="http://www.vatechnologies.com/eci.htm">http://www.vatechnologies.com/eci.htm</a>	Embeddable instrument for corrosion, temperature, chloride ion concentration monitoring	Embeddable instrument capable of measuring parameters important to long term corrosion monitoring including linear polarization resistance (LPR), open circuit potential (OCP), resistivity, chloride ion concentration ([Cl <sup>-</sup> ]) and temperature	High rise buildings, parking garages, bridges, dams, spillways, flood control channels, piers, pylons and erosion control structures	ECII	
5	Vetek Systems Corporation <a href="http://www.veteksystems.com">http://www.veteksystems.com</a>	Embedded, permanent passive electrode	Monitoring for corrosion, and corrosion rate	Rebar, stay cables inside ducts, pre-tensioning cables in beams, decks, or piers, post-tensioning cables inside ducts, suspension cables	V-2000	Iowa, Texas, Delaware

intended usage, Table S9 also provides linkages to websites, which provide details about the technology. Descriptive summaries of instrumentation for corrosion, displacement and cracking are presented in Tables S10, S11 and S12, respectively.

**Table S11. Smart Bridge Instrumentation for Displacement/Strain**

No.	References	Smart Bridge Installation/Type	Description	Primary Use	Proprietary Name	State
1	Geonor <a href="http://www.geonor.com">http://www.geonor.com</a>	Weldable Vibrating Wire Strain Gauge for reliable monitoring of strain in steel and concrete	Monitoring system for reinforced and pre-stressed concrete structures		Geonor P-280W	
2	Geonor <a href="http://www.geonor.com">http://www.geonor.com</a>	Uniaxial Inclinometer for structures and foundations	Monitoring Bridges, Offshore structures, Slopes, Subsea structures, Foundations	Stationary monitoring of the inclination of large structures	Geonor P-600	
3	SOFO System <a href="http://www.smartec.ch">www.smartec.ch</a>	Single Deformation/strain System	Monitoring Bridge Decks, Beams, Girders	Monitoring strain in rebar or surface strain in concrete. Can be embedded or surface mounted		

**Table S12. Smart Bridge Instrumentation for Cracking**

No.	References	Smart Bridge Installation/ Type	Description	Primary Use	Proprietary Name	State
1	Geonor <a href="http://www.geonor.com">http://www.geonor.com</a>	Extensometers for reliable monitoring of crack and joint displacements	Monitoring system for reinforced and pre-stressed concrete structures	Accurate monitoring of crack and joint displacements in concrete and rock	Geonor P-270	

## Weigh-in-Motion Technology (WIM)

Weigh-in-motion (WIM) technology is proposed as an essential component of any smart bridge system. WIM systems include the following pavement-based types:

- Bending Plates;
- Capacitive Mats;
- Load Cells;
- Piezoelectric; and
- Quartz Cable.

Bridge Weigh-In-Motion (B-WIM) systems automatically collect axle loads and gross vehicle weights of trucks traveling at highway speeds over an instrumented bridge. Because the measurements are taken over the relatively long period during which the vehicle is passing over the structure, dynamic effects have less influence over the results than pavement systems that normally “sense” each truck axle weight over very short durations.

A summary of WIM system accuracy is shown in Table S13. However, for the full potential accuracy of the pavement type systems to be achieved, the conditions at and around the site must be perfectly smooth with no ruts or cracks, and must be installed in arrays of ten to average out the errors due to dynamic effects. This has led to the proposition that B-WIM systems are inherently more accurate than pavement type systems.

**Table S13. Summary of WIM System Accuracy**

<b>TECHNOLOGY</b>	<b>ACCURACY</b>
Bending Plate	0 to 12%
Capacitive Mat	0.5 to 1.5%
Load Cell	0 to 6%
Piezoelectric	3 to 30%
Quartz cables	<10%
<b>B-WIM</b>	<b>0 to 3%</b>

Life cycle cost analysis suggests that, on the average, the annual cost associated with maintaining a pavement-based system would be on the order of \$21,000, with a breakdown shown in Table S14. Since B-WIM operations would not require special pavement or site maintenance costs, life cycle costs could be expected to be lower by up to about 25%.

**Table S14. Estimated Average Annual Costs for Maintaining a Pavement-Based WIM System**

Pavement rehabilitation	\$2,280
Other site maintenance	\$2,500
Sensor replacement	\$825
Electronics replacement	\$750
Calibration costs	\$11,000
Office costs	\$1,150
Travel and per diem	\$2,500
<b>Total annual costs</b>	<b>\$21,000</b>

### Strengths and Weaknesses of Each System

Table S15 presents an assessment of the strengths and weaknesses of the smart bridge sensors identified above; neither WIM nor B-WIM technologies are included.

### Recommendations to Improve the Systems Installed

Currently most of the installed monitoring systems provide specific information about a particular measurement such as displacement, strain, corrosion rate, etc. Integrated systems that monitor different aspects of the structure response, store data, and intelligently process this information to provide the engineer information critical to maintenance of the structure are required. Some such systems are currently under development. One example is the Structure-Monitoring-System SMS 2001<sup>®</sup> ([Source: "www.smartec/ch"](http://www.smartec/ch)) used for multi-component-analysis of dynamic and static structural parameters. This concerns maintenance-free remote monitoring of structures. In this

**Table S15. Strengths and Weaknesses of Smart Bridge Systems**

<b>Instrumentation currently in Use</b>	<b>Strengths</b>	<b>Weakness</b>
Cescor (Milan Italy) <a href="http://www.cescor.it">http://www.cescor.it</a>	Reliability, rugged	Passive sensor: Provides information about state of corrosion and not the rate of corrosion
Force Technology <a href="http://www.force.dk/ciad/">http://www.force.dk/ciad/</a>	Reliability, rugged	Passive sensor: Provides information about state of corrosion and not the rate of corrosion
CorrPro Companies Inc. <a href="http://www.corrpro.com">http://www.corrpro.com</a>	Instrumentation available for active and passive corrosion monitoring	Expensive and proprietary
Virginia Technologies Inc <a href="http://www.vatechnologies.com/eci.htm">http://www.vatechnologies.com/eci.htm</a>	Instrumentation available for active and passive corrosion monitoring	Expensive, proprietary and size not suitable for embedding in slabs
Vetek systems Corporation <a href="http://www.veteksystems.com">http://www.veteksystems.com</a>	Ease of implementation, Relatively inexpensive, reliable	Intended primarily for passive monitoring
Geonor <a href="http://www.geonor.com">http://www.geonor.com</a>	Inexpensive, easy to install	Sensitive to vibration, require care when exposed to environment
SOFO System <a href="http://www.smartec.ch">www.smartec.ch</a>	Relatively independent of vibrations	Expensive

system, data is collected, recorded and transferred over the entire observation period both continuously and depending on an event. Such a system makes analysis of static and dynamic structural reactions on user actions and environmental influences possible. In this way comprehensive information about the structural behavior can be achieved over the observation period.

It is also recommended that B-WIM technology be coupled with corrosion deterioration sensors and other deflection and strain monitoring devices to improve the quality of data necessary to perform accurate in-situ evaluation of the behavior of an instrumented bridge and obtain estimated projections of its safe life. This information can be included in the bridge rating process as described by the AASHTO Manual for condition evaluation and load and resistance factor rating (LRFR) of highway bridges. The AASHTO LRFR procedure has been developed to utilize information on the in-situ loading and response of a bridge using traditional technology. Updated rating procedures can be developed in the future to take advantage of new sensor technology.

# PART A: ENERGY ABSORBING FENDER SYSTEMS

## INTRODUCTION

Bridge pier protection is of concern to both the NJDOT and FHWA, in respect of the safety of bridge structures in navigable waterways in New Jersey. Bridge structures in navigable waterways are at risk of being damaged when struck by marine vessels. Currently fender systems are installed around the piers as rigid barriers, which provide protection. However, in any collision, these barriers are themselves damaged or destroyed and require repairs. It is desired that Bridge Fender Systems be identified, that absorb and deflect any impacts without damage to the system, thus preventing extensive repairs. This study has required an extensive literature search into state of the art protection systems used by other states, and any commercially available systems that are in use throughout the world.

## Background Statement

A model to determine vessel collision forces applicable for designing bridge elements has been developed in the “*AASHTO Guide Specification and Commentary for Vessel Collision Design of Highway Bridges*”.<sup>(20)</sup> The bridge piers can thus be designed to withstand the expected impact loads or a protection system can be specified to prevent, redirect or reduce the impact loads on the bridge piers and abutments. If the force resistance of the protective system is higher than the vessel crushing force, the bow of the vessel will crush and the vessel will primarily absorb the impact energy. If the vessel crushing force is higher than the resistance of the protective system, the impact energy will be primarily absorbed by the deflection and the crushing of the protective system. Because damage to the vessel may result in serious environmental consequences such as spilling of oils and other chemicals, an efficient protection system should be designed not only to protect the bridge structure but also to protect the vessel and the environment. The current practice in the design of protective systems is based on energy considerations. Thus, the kinetic energy of the vessel just before impact is transformed into an equal amount of energy that must be absorbed by the protective system through deformation. The types of protective systems can be classified as: 1) Fender Systems; 2) Pile Supported Systems; 3) Dolphin Protection; 4) Artificial Island; and 5) Floating Protection Systems.

Fender systems that are currently installed around bridge piers act as rigid barriers that exhibit high levels of damage or even total destruction, requiring major repairs after collision impacts. The purpose of this project has been to collect information about available types of fender systems that would be able to absorb energy without major damage to the system, thus preventing extensive repairs. Ideally, such fenders can be modeled as linear elastic systems under the effects of impacting forces. To be effective in absorbing the energy without producing damage to the system, the elastic limit of the fenders should not be exceeded, i.e., the impacting force should be low enough so that the fender will deflect under the effect of the force but return to its original position after impact. In general, fender systems are adequate to absorb the collision energy and



forces associated with medium to small vessels at low impact speeds and at oblique angles, rather than head-on collisions. Because of the limitations on the maximum force that any fender system can sustain without causing any permanent damage, the available systems must be rated based on the impacting force.

According to the AASHTO Guide Specifications, the expected impacting force depends on the type of vessels traveling in a water channel, including vessel deadweight, size and speed of travel. The final design should also take into consideration the risk of collision, which depends on the geometry of the channel and the size and number of vessels. Such issues have been thoroughly investigated and described in the AASHTO Guide Specifications. Both the probability of vessel collision and the expected collision forces resulting from the collision, and the expected type of damage given an impact, are important parameters for a risk-benefit analysis that should be associated with determining the appropriate pier fender system design for particular water channels.

Pier fender systems can be made of timber, steel, concrete, or rubber, and are located directly on bridge piers. While timber, steel and concrete fenders are usually crushable and can be damaged irreparably at high impacting forces, the high elasticity inherent in rubber results in relatively high energy absorption characteristics. Timber fenders are composed of vertical and horizontal wood beams that can be attached to a pier or erected adjacent to the pier. Timber is commonly used because of its low cost. However, timber fenders are most effective against minor collisions and are generally not created in sizes that would protect against a major vessel. Concrete fenders are hollow, thin-walled concrete box structures that diffuse impact energy through buckling and crushing of the concrete walls. Steel fenders offer the same kind of energy diffusion as a concrete fender; however, with this application, timber fenders should be attached to prevent sparks when steel-hulled vessels meet steel fenders.

Rubber fenders are available in a variety of shapes and can be purchased commercially. They absorb impact through compression, bending, and shear deformations or a combination of all three. Rubber fender systems also have the advantage of low maintenance costs and high durability. Pier mounted rubber fenders have successfully served to absorb some of the impact forces after collisions, reducing the final force on the pier and avoiding permanent damage. A preliminary search has identified a number of fender providers that produce such types as laminated rubber, molded rubber, and foam rubber fenders for use on piers. These improved rubber products have helped improve the efficiency of rubber-based fenders for pier protection. For example, the load deflection, energy absorption, and chemical properties of laminated rubber have made them a preferred choice over virgin extruded and molded rubber for marine vessels and structures. Foam pier fenders are made of spirally welded, ionically cross-linked ionomer foam. Ionomer resins are high-grade thermoplastic polymers that have the unique ability to link with neighboring molecular chains with the same bond as the polymer chain itself. Because of the unique ionomer foam construction, the fenders have improved strength and energy absorption capability.

Freestanding pile-supported structures consist of pile groups connected by rigid or flexible caps. Dolphins are circular cells, generally 33-66 ft in diameter, constructed of driven steel sheet piling and filled with rock or concrete. Besides protective islands, which are highly effective in protection of piers against vessel collision, there are also several types of floating systems available for pier protection. The disadvantages of floating systems are questionable durability; blockage of large portions of a waterway to recreational boats and an inability to stop ships with sharply raked bows. The most common floating systems are anchored pontoons, cable net systems and floating shear booms. Pneumatic and hydraulic systems have also been developed.

Since collisions, whether minor or major, do occur and fenders are first to get damaged, it is important to develop fender systems that would protect the bridge without much damage to the protection system itself. This would alleviate costly and time-consuming repairs. Energy absorbing fenders have been identified as systems with potential to provide protection for bridges with minimal post-collision maintenance requirements. The limited survey of literature that follows, points to the conventional as well as state-of-the-art systems.

## **LITERATURE SURVEY**

### **Bridge Pier Collisions Survey**

Vessel collisions with bridges are increasing at an alarming rate, as more vessels are making more frequent trips under more bridges. Until 1991, the direct impact of bridge collision forces was neglected in the bridge design process, and as a result, many older bridges are vulnerable to catastrophic failure. A brief survey of literature, as shown in Table A1, is illustrative of the ramifications of poor protective systems. Properly designed fender systems protect the bridges against catastrophic failures, such as the 1993 vessel collision with an Amtrak bridge in Alabama, costing 47 lives and millions of dollars. Fourteen motorists were killed in May 2002 when the 99-foot-long towboat Robert Y. Love, pushing two empty 298-foot-long barges on the Arkansas River, veered off course and struck the Interstate 40 Bridge in Webbers Falls, Oklahoma (Figure A1). This collision renewed concerns about the protection of highway and railroad bridges from collisions with vessels. The National Transportation Safety Board recommended that states survey all bridges over waterways to assess the risk of collision with vessels, but the Federal Highway Administration did not adopt this recommendation. The I-40 Bridge was built in 1967 and was rated satisfactory by the Oklahoma DOT. The state's DOT had done a ship-bridge collision survey of its bridges across the Arkansas River, but concluded that the probability of a ship striking the outer pier of the I-40 Bridge was small. Fenders were, therefore, provided on the upstream side of the two bridge piers next to the navigation channel, with none on the downstream side.<sup>(21)</sup>



**Figure A1. I-40 Bridge, Arkansas River**

(A section of roadway rests on the barge that knocked out the supports of the I-40 Bridge across the Arkansas River. The piers that collapsed were about 200 feet from the channel)

Another collision between a 685-foot oil tanker and a bridge in Portland, Maine, illustrates the importance of bridge design in minimizing damage and injuries. A tanker transporting 11.3 million gallons of No. 6 fuel oil from a refinery in the U.S. Virgin Islands struck the Casco Bay Bridge. The 31,709-grt tanker hit the bridge on its port side between the No. 1 cargo tank and the forepeak. But a fender system protecting the bridge pier absorbed the impact. There were no injuries to the crew, no oil was spilled, and no damage was done to the vessel.<sup>(21)</sup>

The Hawk incident was in stark contrast to a collision that occurred on September 27, 1996, when a 560-foot oil tanker, Julie N, struck the old bridge in Portland, which was protected by timber fenders. The collision resulted in a 33-foot-long tear in the vessel's hull and 168,000 gallons of oil spilled into Portland Harbor. The accident caused about \$660,000 worth of damage to Julie N, and the resulting oil spill cost \$46 million to clean up, according to the final report from the National Transportation Safety Board.<sup>(21)</sup>

It took the 1980 collapse of the Sunshine Skyway Bridge in Florida, and the resulting loss of 35 lives before action was taken in the U.S. to standardize protection procedures for bridges. Besides loss of life and injury in major collisions, ceaseless damage to the bridges and fender systems has taken a toll on the resources of state transportation agencies and other owners of bridges. According to a 1996 report by the Federal Highway Administration,<sup>(1)</sup> typical cost for adding protection or retrofitting existing bridges can run anywhere from 25% to 100% of the original cost of the bridge itself. Including protection in the original cost of a new bridge can range from 5 to 50% more than an unprotected facility, but far less than the costs resulting from a collision.

**Table A1. Major Ship Collisions with Bridges**

<b>Location</b>	<b>Year</b>	<b>Lives Lost</b>	<b>Others</b>
CSX/Amtrak Railroad Bridge, USA	1993	47	
Claiborn Avenue Bridge, USA	1993	1	
Hamburg Harbor Bridge, USA	1991	0	
Volga River Railroad Bridge, Russia	1983	176	
Tjorn Bridge, Sweden	1980	8	
Sunshine Skyway Bridge, USA	1980	35	
Pass Manchaca Bridge, USA	1976	1	
Tasman Bridge, Australia	1975	15	
Sidney Lanier Bridge, USA	1972	10	Bridge/pier destroyed
Old bridge in Portland Maine	1996		\$46 million to clean oil spillage
1-40 Bridge Arkansas river Oklahoma	2002	14	Bridge/pier destroyed
Casco Bay Bridge US Virginia	2002	0	No major Damage.

**Pier Protection**

In 1988, due to the increasing number of shipping accidents with bridges, a pool-funded research project sponsored by 11 states and the FHWA was initiated to establish design specifications for ship impact with bridges. The findings were adopted by AASHTO, and are presented in the Guide Specifications and Commentary for Vessel Collision Design of Highway Bridges (AASHTO 1991). These guidelines provide two alternatives for bridge design: 1) design bridge elements to withstand ship impact force; and 2) design pier protection systems.<sup>(3)</sup>

Research done by FAMU-FSU College of Engineering to investigate the adaptability of the existing bridge fender systems as pier protection elements against vessel impact, included: (1) static analysis using the equivalent force equation from AASHTO (1991) and performed with ANSYS, version 5.5; and (2) dynamic analysis, employing a model of a barge, performed with LS-DYNA version 950. It was concluded that bridge fenders have a potential to be used as an energy absorbing system for errant barges, and their crashworthiness can be improved by retrofitting them. It was further concluded that a retrofitted fender is capable of absorbing up to 70% of the kinetic energy of the barge impacting with the assumed collision velocity (3.8 knots, the maximum current

prediction for reference stations in Florida, since accidents involving barges and bridges are more likely to occur when barges are detached from tow boats). For an initial impact angle of 30 degrees or less, an energy absorbing system is capable of redirecting the barge and saving the bridge pier.<sup>(3)</sup>

It is important to note that although bridge pier fender systems have been around for quite some time, until now they have not been designed to withstand any specific lateral design force; their existing impact capacity is therefore unknown. A recent study reports on the evaluation of crashworthiness of the system and development of more effective retrofit systems.<sup>(1, 3)</sup> The research efforts in this study were concentrated on computational analysis of a jumbo hopper barge impacting a commonly constructed fender. A nonlinear explicit dynamic finite element code was used for analysis. Various initial velocities and impact angles were used to represent possible collision conditions. Computational analyses were adopted to assess the crashworthiness performance of the constructed fender system and it was used to identify the weakest components of the possible retrofit.

The U.S. Army Corps of Engineers (USACE) recently conducted full-scale barge impact experiments.<sup>(4)</sup> The experiments were conducted at the Waterways Experiment Station to assist in the verification of the current barge impact methodologies being utilized in the design of energy absorbing fender systems. These full-scale experiments utilized four- and fifteen-barge tow configurations. The flotillas were fully ballasted to approximately 9 ft (3 m) of draft and laid out with state-of-the-art instrumentation to record the actual impact force and the behavior of the system during impact. The angles and speeds of the tow at impact during these experiments ranged from 0.5 to 4.1 ft (0.2 to 1.2 m) per second, at angles of impact from 5 to 30 deg. The results from these experiments will be used to further define and develop the barge impact numerical models and assist with design procedures to be used in USACE projects.

Barge tows can generate large forces on impact, but the energy released by a large ocean-going vessel in collision can be astronomical. Besides bracing a pier with crash walls or mass concrete as appropriate, local practice suggests fender systems for barge traffic can be comprised of large dolphins or, preferably, sand and rock islands for ocean-going traffic. Currently, the U.S. Coast Guard requires that non-sparking material be used for the horizontal wales that come into contact with the vessel, to minimize the possibility of ignition of flammable material. Steel members must have a timber or plastic facing. It has been determined that fender systems will sustain less damage if they consist of vertical piling only, instead of bracing with battered piling according to past practice. Large electrometric energy absorbers are available to ease the force on the support members given the forces to be resisted. Accurate analysis of a fender system is very complicated, but computerization of fendering systems provides some insight into this.<sup>(22)</sup>

### **Available Fender Systems**

Table A2 in Figure A2 presents a summary of existing fender systems, along with their advantages and disadvantages. It is also reproduced in this document in the following pages.

(Double click the xls icon below for the table)

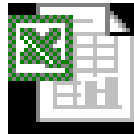

Available fender  
systems -comparison.

**Figure A2. Available Fender Systems**

**Table A2. Available Fender Systems**

TYPES	DESCRIPTION	ADVANTAGE	DISADVANTAGE
<b>A. STD PILE-FENDER SYSTEMS</b>	Employ piles driven to the bottom of the sea. Energy upon a fender pile is absorbed by deflection and the limited compression of the pile. Energy-absorption capacity depends on the size, length, penetration, and material of the pile and is determined on the basis of internal strain-energy characteristics.		
1. Timber pile	Consists of timber members. A contact frame is formed that distributes impact loads.	Low initial cost and abundant timber piles.	Limited energy-absorption susceptibility to mechanical/biological damage.
2. Steel pile	Used in water depths greater than 40 feet.	Strength and feasibility for difficult seafloor conditions.	Vulnerability to corrosion and high initial cost
3. Concrete pile	Pre-stressed concrete piles with rubber buffers at deck level have been used.	Resists natural and biological deterioration.	Limited strain-energy capacity and corrosion of steel through cracks.
4. Composite pile	Composite pile is a cylindrical shell fabricated of high-strength fiber reinforced composite materials.	High-energy absorption. Resists natural and biological deterioration.	High initial cost.
<b>B. RETRACTABLE FENDER SYSTEM</b>	A retractable fender system consists of vertical-contact posts connected by rows of Wales and chocks. The fender retracts under impact, thus absorption capacity depends directly on the effective weights, the angle of inclination of the supporting brackets and the maximum amount of retraction of the system.	Negligible effects of bio-deterioration on energy absorption capacity. Low maintenance cost. Minimum equipment requirements.	Vulnerability to corrosion of the supporting brackets. High initial cost if used on open type piers.

TYPES	DESCRIPTION	ADVANTAGE	DISADVANTAGE
<b>C. RUBBER-IN-COMPRESSION</b>	Rubber fender consist of two major types, rubber-in-compression and rubber-in-shear		
1. Rubber-in-compression	Consists of a series of cylindrical rubber or rectangular tubes installed behind standard fender piles. Energy absorption is achieved by compression of the rubber. Absorption capacity depends on the size of the buffer and on maximum deflection. The energy – absorption capacity can be varied by using the tubes in single or double layers, or by varying tube size.	Simplicity and adaptability plus effectiveness at reasonable cost.	High concentrated loading may result. Initial cost is higher than standard pile system without resilient units.
2. Rubber-in-shear	Consists of a series of rubber pads bonded sandwiches mounted firmly as buffers between a pile-fender system and a pier. Two types of mounting units are available: the standard unit or the overload unit, which is capable of absorbing 100% more energy.	Capability of cushioning impact from lateral, and vertical directions. High-energy absorption capacity. Favorable initial cost.	Too stiff for small vessels. Steel plates subject to corrosion. Problem with bond between steel plate and rubber.
3. Lord flexible	Consists of an arch-shaped rubber block bonded between two end steel plates. It can be installed on open or bulkhead-type piers, dolphins, or incorporated with standard pile or hung fender systems. Impact energy is absorbed by bending (buckling) and compression of the arch-shaped column.	High energy-absorption. Low terminal-load characteristics.	Bond between steel plates and rubber plus possible fatigue problems.
4. Rubber-in-torsion	Rubber and steel combination fabricated in cone-shaped compact bumper form, molded into a specially cast steel frame, and bonded to the steel. It absorbs energy by torsion, compression, shear and tension but most energy is absorbed by compression.		



<b>TYPES</b>	<b>DESCRIPTION</b>	<b>ADVANTAGE</b>	<b>DISADVANTAGE</b>
5. Pneumatic	Pneumatic fenders are pressurized, airtight rubber devices designed to absorb impact energy by the compression of air inside a rubber envelope. Energy-absorption capacity and resistance to load depend on the size and number of tires used on the initial air pressure when inflated.	Suitable for both berthed and moored ships.	High maintenance cost.
<b>D. GRAVITY-TYPE FENDER SYSTEM</b>	Gravity fenders are normally made of concrete blocks and are suspended from heavily constructed wharf decks. Impact energy is absorbed by moving and lifting the heavy concrete blocks.	High energy-absorption.	Heavy equipment requirement initial and maintenance costs are high.
<b>E. HYDRAULIC/ PNEUMATIC FENDER SYSTEMS</b>			
1. Dashpot hydraulic	Consists of a cylinder full of oil or other fluid so arranged that when a plunger is depressed by impact, the fluid is displaced through a non-variable or variable orifice into a reservoir at higher elevation. Suitable where severe wind, wave swell and current condition exists.	Favorable energy absorption characteristics.	High initial and maintenance costs.
2. Hydro-pneumatic floating fender	This is a system of floating rubber envelopes, filled with water or water and air, which absorbs energy by viscous resistance or by air compression.	Favorable energy absorption characteristics.	High initial and maintenance costs.
<b>F. FLOATING FENDER SYSTEM</b>	Consist of floating logs which ride up and down against the timber breasting face.	Easy application. High water depths.	Low energy absorption.

Rubber fender systems are capable of absorbing high levels of energy during impact. However, multitudes of systems are available and this has complicated selection of the appropriate systems for applications. It is essential to look into the guides and standards developed by various agencies, associations, and manufacturers in order to acquire insight into the attributes of the various systems. The standards established by the Permanent International Association of Navigation Congresses (PIANC) for the design of fender systems provide such guidelines for system selection.<sup>(5, 6, 7)</sup> Another source is the Advanced Pier Concepts Users Guide, which consolidates several naval civil engineering laboratory (NCEL) documents.<sup>(8)</sup> This document has been available for shore facilities planners and designers of navy piers.

The design of fender systems for bridge piers is based on fundamentals of physics and simple pile equilibrium. Certain assumptions can lead to grossly over-designed systems or to inaccurate force evaluation in the entire support system. In order to improve the state of the art and provide accurate design data, while maintaining simple design standards, the U.S. Coast Guard and other agencies initiated a comprehensive design study in the late 70s. The study included examination of the state of the art in bridge fender systems, development of improved design criteria, preparation of spring constant curves for various types of fenders, and presentation of design examples.<sup>(2, 9)</sup>

Fiber Reinforced composites provide attractive alternatives to conventional fender materials. The use of composite plastic materials eliminates the problem of attack by marine organisms, and the environmental consequences of creosote treatment of timber piles.<sup>(15, 16, 17)</sup> The Army, as well as San Diego and New York Port authorities have tried these systems. The pilings are made from molded hollow tubes of advanced composite materials including glass fiber and vinyl ester resin. Recycled plastic sheaths around the tubes provide an abrasion-resistant outer surface. The structural composite materials are strong, lightweight, highly corrosion resistant, and immune from sea worm attack. Although the materials for the composite pilings are more expensive than wood or concrete, the piling and fender system will be more durable and cost effective than traditional alternatives.

Review of literature indicates existence of only a modest number of systems exhibiting energy absorbing characteristics. For instance, a new Wide-flange beam system that incorporates energy-absorbing technology has been developed and crash tested as guard rails, but has potential for use as an energy absorbing fender.<sup>(18)</sup> It incorporates an impact head designed to dissipate impact energy by producing a series of plastic hinges in the W-beam as the impact head is compressed. The energy-absorption mechanism allows the W-beam to absorb large amounts of kinetic energy. Another new biaxial elasto-plastic energy absorbing device has been developed and tested for application in bridge fenders.<sup>(19)</sup> The device is promising and it is made up of bended U-shaped steel elements arranged in a radial pattern. Each element can deform along any direction. The radial arrangement allows for a full exploitation of the energy dissipating capability of each element as well as for the possibility of calibrating the

resisting forces in the horizontal directions. The experimental and the numerical results show a good non-linear behavior of the u-elements as well as of the complete device, with high-energy dissipation capacity and allowance for large displacements.

### **Fender System Selection**

A variety of factors affect the proper selection of a fender system. These include local marine environment, exposure of harbor basins, class and configuration of ships, speed and direction of the approach of ships when berthing, available docking assistance, type of berthing structure, and even the skills of pilots or ship captains. It is considered impractical to standardize fender designs since port/navigable channel conditions are rarely identical. Previous local experience in the application of satisfactory fender systems should be considered, particularly as it applies to cost-effectiveness characteristics.

For locations where berthing operations are hazardous, stiff fender systems with high-energy absorption characteristics, such as rubber-in-axial-compression pile fender systems are advisable. For an open pier, any type of fender system may be applicable. For a solid pier, the use of resilient or retractable fenders to minimize vessel damage may be considered.<sup>(20)</sup>

### **Fender Purchase Considerations**

There is no way to be absolutely assured of purchasing the optimum-design fender for a given application, especially given the wide variety of ships that call on most ports, and thus create varying berthing situations. However, a good specification can minimize the chance of purchasing a truly below par design.<sup>(22)</sup>

The general approach of using “performance-based” specifications is sound, and is maybe the best method to ensure adequate systems. The problem with most current specifications stems from changes that have taken place within the fender industry over the last ten years. Previously, there was a certain general equivalence of design and quality among the various manufacturers, and defining certain common variables gave reasonable assurance of getting the expected serviceability. Today, that is definitely not the case. As more and new manufacturers come on the scene copying established fender manufacturers’ products, or their design solutions, the end product will not be the same as expected. There are many variables that can be changed to reduce the cost of a fender system. The effects of these changes are often not known for many months, and cannot always be predicted, but can lead to significant degradation of the fender’s suitability for the intended service. Thus, fender specifications need to define owners’ expectations in ways that protect the owner absolutely in performance, serviceability, and life expectancy. To be reasonably assured of receiving the specified dynamic performance, specifications should require suppliers to test the performance of at least 5%, or a minimum of two, of every different fender supplied. Furthermore, testing should be witnessed by an independent third party. Test results should convince the

project engineer that the fenders will provide the designed energy absorption and reaction forces under the design conditions.<sup>(6)</sup>

PIANC, the International Navigation Association (formerly Permanent International Association of Navigation Congresses) is working on recommendations for fender-testing methodology.

***Finally, but perhaps most importantly, is the AASHTO Guide Specifications and Commentary for Vessel Collision Design of Highway Bridges,<sup>(20)</sup> which contains a model to determine vessel collision forces applicable for designing bridge elements. According to this guide, the expected impacting force depends on the type of vessels traveling in a water channel, including vessel deadweight, size, and speed of travel. It is suggested that final fender system design should take into consideration the risk of collision, which depends on the geometry of the channel and the size and number of vessels. Risk analysis is critical in the cost-effectiveness evaluation of alternative fender systems. This is presented at length in the DESIGN PROCEDURES section of this report.***

## Vendor and Installation Survey

### **SEAPILE® & SEATIMBER® Composite Marine Products**

SEAPILE and SEATIMBER composite marine products are plastic piling and timbers made from 100% recycled plastic, which provide alternatives to traditional chemically treated wooden piling and timbers (Figure A3). Reinforced with fiberglass rebar for added strength, SEAPILE and SEATIMBER Composite Marine Piling and Timbers are also abrasion resistant, and the plastic matrix incorporates ultraviolet inhibitors to ensure a long life. They are environmentally safe and are impervious to marine borers.



**Figure A3. Seapile & SeaTimber Marine Composite**

### **Hardcore Composites**

Hardcore Fender and Dolphin Systems are custom designed for each situation. Fenders are secured to the outside of the composite piles to protect the dock or pier. Dolphins are used to deflect boats as they negotiate narrow waterways or hairpin turns.

## **Promar, LLC**

### ***Foam Filled Marine Fenders***

ProMar foam filled marine fenders are high-energy absorption, elastomeric marine systems used to provide protection to ships, wharves and piers in vessel- to-vessel or vessel-to-facility operations. The fenders are constructed with a heavy-duty closed cell, cross-linked polyethylene (PE) foam core that absorbs energy as the fender is compressed. The fender's outer shell is made of an abrasion resistant, polyurethane (PU) elastomer material that is specially formulated for marine use. This durable outer skin resists tears, punctures and degradation from exposure to chemicals, water and other environmental effects. Galvanized steel end fittings, connected by a heavy-duty internal chain, provides for the fender attachment. Fixed and swivel end connections are available.

ProMar fenders can be supplied in netless or netted type. The netless fender has a heavy duty, smooth exterior surface which is very durable and abrasion resistant. The ProMar netted foam filled fender includes Super-Net made with heavy-duty chain, fittings, and tractor/aircraft tires for superior performance and durability. The Super-Net is modular in construction to facilitate easy maintenance.

All ProMar marine fenders are manufactured to comply with U.S. and International Government Specifications, and meet the requirements of worldwide marine regulatory agencies.

### ***Donut Type Monopile Fenders***

ProMar Donut-Type Monopile Fenders are special purpose foam filled fenders which are installed on a fixed monopile (Figure A4). The fender and the pile act as an integrated system to absorb energy and resist reaction forces imparted by vessel impact or other external forces. The monopile fender is free to rotate on the pile and it moves vertically on the pile as it floats with changing water level.

ProMar Monopile Fenders are constructed of energy absorbing foam which surrounds a steel core. The resilient closed cell foam absorbs energy and provides protection to the pile. The fender foam body is covered with an abrasion resistant reinforced polyurethane outer skin. Low friction bearing surfaces are provided between the pile and the fender unit. The Monopile fender is ideally used in applications for which rotational and vertical fender movement and omni-directional energy absorption may be required.



**Figure A4. ProMar Donut Type Monopile Fender**

ProMar Monopile Fender applications include:

- Breasting Dolphins
- Mooring Dolphins
- Turning Dolphins
- Ferry Berths
- Pier Corner Protection
- Lock and Dry-dock Entrance

Features and advantages include:

- Fender Rotation on the Pile
- Floats on the Water Surface
- Abrasion Resistant Outer Skin
- Unsinkable Foam Body

**Maritime International, Inc.**

Maritime International, Inc. markets a line of UHMW-PE marine plastic material utilized for fendering applications for docks, piers and bridge applications. A wide range of sizes, thicknesses and colors of virgin material, as well as reprocessed material, is offered (Figure A5). They are marketed as being:

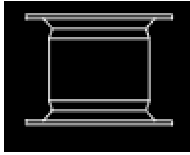

Cell



Leg

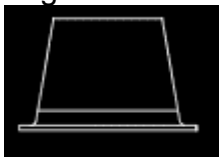

Cone

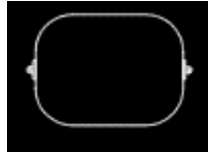

Foam

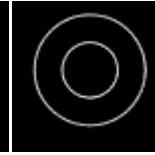

Cylindrical



D-D Bore



D-O Bore



Wing



Trapezoidal

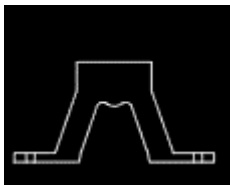

Arch



Monopile

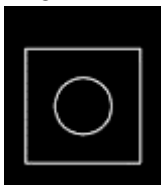

Square

**Figure A5. Marine Plastic Fenders**

- Able to allow vessels to glide/travel along surface of fender without damaging the hull.
- Impervious to water and chemicals.
- Resistant to corrosion.
- Deployable as rubber fender panel facing, pile rubbing strips and inner bridge wall facings (Figure A6)



**Figure A6. UHMW Marine Plastic Material Panel Facing**

### **Urethane Technologies, Inc.**

Urethane Technologies, Inc. manufactures collision survivable products, which are available in a wide array of designs, shapes, configurations and colors (Figure A7). In addition to its standard product line, fenders or other floatation devices can be custom designed and manufactured for customers' particular needs. The floatation foam used is a closed cell, cross-linked polyethylene foam which has a much lower moisture vapor transmission rate than other floatation foams. The foam will not absorb any significant amount of water during long-term immersion. The floatation foam is protected by the company's Seathane<sup>®</sup> polyurethane skin. This skin has a 500% elongation and a 4500 lbs/sq. inch tensile strength. For products that will receive rough abuse, the skin is reinforced with Spectra<sup>®</sup> fiber which has a 375,000 lbs/sq. inch tensile strength.

### **Viking Fender**

Viking "Softlite" Foam Ship and Pier Fenders are reputed to be the longest-lived, lightest heavy-duty ship and pier fenders available (Figure A8). They are easy to use, safe to handle and require few personnel and light equipment to deploy and retrieve. The fenders are finished with an integral skin of high-density foam that is flexible, tough, and non-abrasive. Ionomer foam construction provides the fenders with high strength and integrity, combined with high-energy absorption and a nearly impenetrable skin.





**Figure A7. Urethane Products**



**Figure A8. Viking Fenders**

**Svedala/Trellex**

Svedala/Trellex is a subsidiary of J. H. Menge & Company, Inc., a producer of specially engineered marine fendering and machinery (Figure A9). They are presently in their fourth generation of engineering sales to Gulf Coast shipyards, refineries and terminals, the dock building industry and the offshore oil industry. The company services the needs for heavy marine auxiliary equipment, life-saving equipment, pollution control equipment, terminal equipment and, specifically, engineered dock and mooring equipment. From their office in New Orleans, they cover the Gulf Coast and up-river to Memphis.



**Figure A9. Svedala/Trellex Fender Products**

### **Ultra Poly, Inc.**

Ultra Poly is a service-oriented company with a wide offering of UHMW products from compression-molded sheets to ram extrusion profiles and custom fabricated parts. They offer standard and custom products, diverse sheet sizes, and fabricated parts to meet their customer's individual needs, and are committed to an active partnership between user and manufacturer.

Ultra High Molecular Weight (UHMW) Polyethylene is often referred to as the world's toughest polymer. UHMW is a linear high-density polyethylene, which has high abrasion resistance as well as high impact strength. UHMW is also chemical resistant, has a non-skid surface, and a low coefficient of friction, which make it highly effective in a variety of applications. Ultra Poly's UHMW can be cross-linked, reprocessed, color-matched, machined and fabricated to meet most customer requirements. Examples are shown below in annotated Figures A10, A11, and A12.



Ultra Poly's fire retardant sheets were installed over wooden support structures on the 145th St. Bridge in New York City. Since the river is a main channel for heavy marine traffic, the bright, orange color was chosen for its high visibility. Wooden fender systems present a high fire hazard as well as toxic smoke issues, so Ultra Poly provided a fire retardant UHMW.

**Figure A10. 145th St Bridge, New York, NY**



The design of the fender system used on one of the Duwamish Bridges in Seattle, Washington is unique because the UHMW was manufactured in "T" shaped strips that were cast directly into reinforced concrete. This resulted in a combination concrete and UHMW fender system.

**Figure A11. 1st Avenue Bridge South, Seattle, WA**



Recently, Ultra Poly replaced the wood fenders on the Tappan Zee Bridge with black and yellow UHMW. The wood suffered tremendous damage during the harsh winters when ice flowed down river and built up around the bridge piers. Ultra Poly manufactured the largest possible sheets for large impact surface. A portion of the sheets are partially under water.

**Figure A12. Tappan Zee Bridge, New York, NY**

**Schrader Co.**

The Schrader Company's Plastic Pilings, Inc. offers recycled plastic pilings to meet design engineers' requirements for bending loads, axial loads or a combination of both. Fender and vertical load bearing pilings with a steel pipe core (and fender pilings with fiberglass reinforcing) are available upon request. PPI pilings are immune to all marine borer attacks, so no further protection such as creosote or plastic sheathing is required. PPI pilings are essentially maintenance free. They have been tested in the Los Angeles Harbor since April 1987.

The Schrader Co. also offers a full line of Foam Filled Fenders and Buoys (Figure A13). A thick, tough protective polyurethane elastomeric skin material encapsulates the foam core of fenders. Sizes vary from 3' x 5' to 10' x 20'. Custom designs are available. Integral end fittings are constructed of high quality steel and Hot Dipped Galvanized. The end fittings of fenders are internally connected with a heavy-duty alloy chain. They are constructed of 100% closed-cell cross-linked resilient energy absorbing foam.

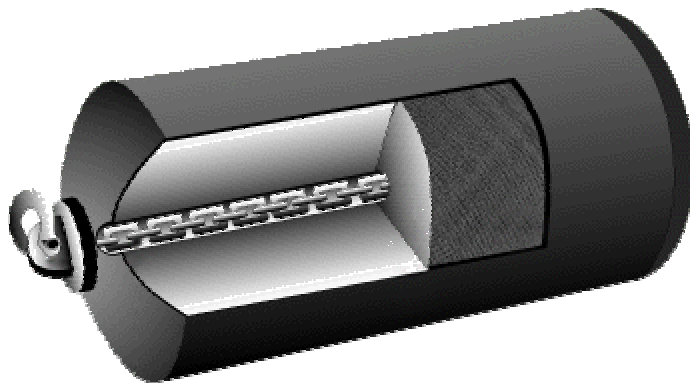

**Figure A13. Schrader Co. Foam Filled Fenders & Plastic Pilings**

### **Schuyler Rubber Company**

Schuyler Rubber Co., Inc. has designed, tested and manufactured laminated rubber fenders since 1950 (Figure A14). Laminated rubber's proven track record of economy, protection, durability, and reliability make it the preferred choice over virgin extruded and molded rubber for tugs, push boats, barges, ferries, piers, docks, dolphins, trawlers, and other marine vessels and structures.

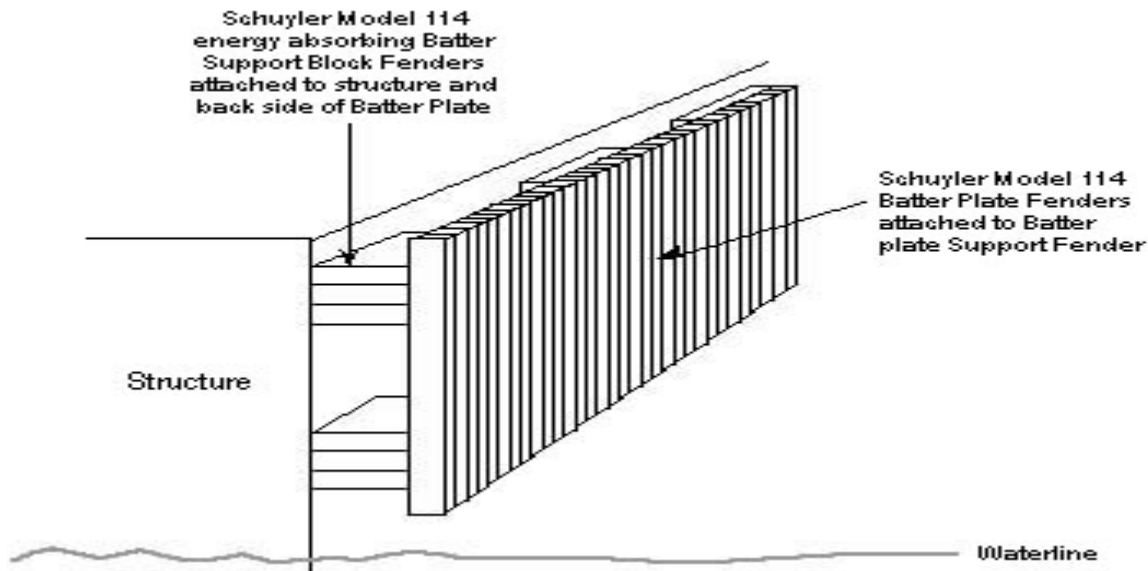

**Figure A14. Schuyler Model 114 Batter Block Fender**

Schuyler Rubber's laminated rubber fenders have been custom built to fit complex shapes and to cover large areas with a continuous sheet of rubber protection, as seen in Figure A15. Laminated rubber contains tough plies of nylon and cloth internal reinforcement, which makes it ideal for the harshest of conditions. The chipping, cracking, and cutting often associated with timber and virgin rubber are virtually eliminated. Laminated rubber is available in an unlimited number of sizes and shapes. The fenders can be pre-curved, tapered, and shaped to meet specifications. The load deflection, energy absorption, and chemical properties of laminated rubber equal or exceed those of virgin rubber.

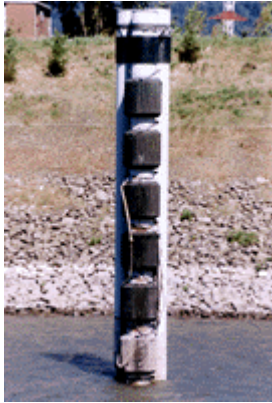

**Figure A15. Schuyler Rubber's Laminated Rubber Fenders**

## **IDENTIFIED STATE-OF-THE-ART FENDER SYSTEMS**

### **Cellular Sheet Pile Dolphin and Fenders**

A pier protection system consisting of cellular sheet pile dolphin and fenders to demarcate the channel can be designed to prevent, or to minimize damage to the bridge piers due to vessel impact. A similar system was able to absorb the impact and prevent damage to both bridge pier and the vessel in May 2002, when a 685-foot oil tanker transporting 11.3 million gallons of fuel struck the Casco Bay Bridge in Portland Maine (Figure A16). Out of a total cost of \$130 million for the bridge, about \$7 million was spent on state-of-the-art fenders around all piers next to the navigation channel. Four 60-foot-diameter steel cellular sheet pile dolphins filled with gravel are located both upstream and downstream of each bascule pier. Each bridge pier next to the navigation channel is also shielded by clusters of 100-foot-long, 36-inch-diameter fusion bonded epoxy coated steel pipe piles and Wales consisting of W24 x 117 rolled beam to form the protective fender system along each edge of the channel. The Wales are faced with ultra high molecular weight (UHMW) polyethylene rubbing strips for decreased vessel impact force due to the very low coefficient of friction. This material was selected for its durability and resistance to deterioration. Efficient energy absorbing kinematic rubber

fenders were introduced at the pier location to provide the minimum offset of the fender, and maximizes the channel width opening to satisfy the navigational clearance requirements of the U.S. Coast Guard. The system is designed to absorb the energy of a 50,000-dwt vessel traveling at 5 knots and striking the fenders at a 15° angle.



**Figure A16. Casco Bay Bridge State-of-the Art Fender System**

### **Donut Monopile Fender Systems**

A DONUT fender is a foam-filled fender, designed to be slipped over a stationary monopile. The fender floats at the water line, and can rotate upon contact with a ship. These features make it ideal for turning dolphins, and in applications where large water level changes occur, such as in rivers or tidal estuaries.

Marine contractors Spearin, Preston and Burrows, Inc., of Staten Island, NY, installed the Floating Donut monopile fender in New York harbor, to prevent the potential for damage of the berthing oil tankers by the riprap near the end of its piers (Figure A17). Since its installation, the dolphin has operated problem-free and without the need for maintenance. Tankers, which bring base stock lube oils from southern refineries, berth at the pier an average of four times a month. Although it is not part of berthing operations, tankers occasionally bump the dolphin. There have been no complaints from the tanker captains or crews since its installation.



**Figure A17. Floating Donut Fender at New York Port**

### **Composite Pile, Fender, and Dolphin Systems**

Composite pile, fender and dolphin systems are custom designed for each situation. Fenders are secured to the outside of the composite pile to protect a dock or pier. Dolphins are used to deflect boats as they negotiate narrow waterways or hairpin turns.

An example of such a system was constructed by hardcore composites for pier ends at Lewes, Delaware Ferry. On July 17, 1997, officials of the Delaware River and Bay Authority (DRBA), joined by representatives of the University of Delaware, Hardcore DuPont Composites, the Federal Highway Administration and local dignitaries, dedicated a state-of-the-art composite pier fender system at the Lewes terminal pier, the largest marine fender application of composite technology in the world (Figures A18, A19 & A20). The project involved replacing more than 1,000 woodpiles with a composite system of 44 fiberglass tubular piles, a stay-in-place fiberglass framework and seven fiberglass fender panels. The new structure is part of a larger system that includes more than 20 composite fenders surrounding the ferry pier, which were installed in 1996. More than 60 similar fenders were installed around the pier in Cape May, N.J., at the same time. The new, lightweight ferry fender system offers ease of installation as well as lower acquisition and life cycle costs over traditional materials like wood. This system was designed to absorb the forces generated by a 210-ton ferry vessel moving at 3 knots.





**Figure A18. Pier End at Lewis, DE Ferry**



**Figure A19. Hardcore Composite Fender Panel**



**Figure A20. Hardcore Composite Panel Facing**

A list of state-of-the-art fender vendors is provided in Table A3, followed by performance ratings for some energy absorption products and composite pilings in Tables A4 and A5, respectively.

**Table A3. List of Fender Vendors and Their Contacts**

<b>VENDOR</b>	<b>PRODUCTS</b>	<b>CONTACTS</b>
PROMAR	-Foam Filled Fenders -Donut Type Fenders -Electrometric Fenders	Promar LLC Tel: 1-800-849-6025 Email: <a href="mailto:Solutions@promar.com">Solutions@promar.com</a>
SEAWARD INTERNATIONAL	-Donut monopile marine fenders -Sea Pile composite marine piling -Sea Guard Fenders	Seaward International, Inc Tel: 1-540-667-5191 Email: <a href="mailto:Sales@seaward.com">Sales@seaward.com</a>
CORTNEY	-Sea Guard marine Fenders	Tel:1-800-775-3915 Email: Sales@cortney.com
ULTRAPOLY	All UHMW polyethylene materials	Tel: 1-800-872-8469 Email: <a href="mailto:sales@ultrapoly.com">sales@ultrapoly.com</a>
SSR	-Ionomer Foam Filled Fender -Extruded Rubber	Tel:1-800-426-3917 Email: <a href="mailto:sales@ssrfenders.com">sales@ssrfenders.com</a>
HARDCORE COMPOSITE	-Composite tubular piling -UHMW Fender panels	Tel: 1-302-442-5900 Email: <a href="mailto:sales@hardcorecomposite.com">sales@hardcorecomposite.com</a>
POLY HI SOLIDUR	-Fender facing polymers.	Tel: 1-800 628 7264 – USA Email: <a href="mailto:tivar@polyhisolidur.com">tivar@polyhisolidur.com</a>
SCHRADER CO	Plastic Pilings	Tel: 1-800-657-1160 Email: <a href="mailto:sales@schraderco.com">sales@schraderco.com</a>
VIKING MARINE	Rubber Pier Fenders	Tel: 1-732-826-4552 Fax: 1-732-826-5533
MARITIME INTERNATIONAL INC.	-All Marine Fenders -Plastic pilings. -UHMW marine products	Tel: 1-866-265-5273 Email: <a href="mailto:info@maritime-international.com">info@maritime-international.com</a>

**Table A4. Performance Ratings for Energy Absorption Products**

FENDERS	PERFORMANCE RATIO AT 60% COMPRESSION				VENDOR
	Available	Energy Absorption	Reaction	Relevant Application	
	Size(ft)	(ft.kip)	(Kip)		
Foam Filled	(2x4)- (10x22)	11.0 -1610.0	20 - 600	Pier corner	Promar
Donut Monopile	4.5-9.0 Diameter 2.0-8.0 Height	4.0 - 64.0	18 -141	Bridge pier protection dolphin	Seaward
Sea Guard Marine	(2x4)- (14x28)	11.0 - 4000	20 -1130	Docks & pier protection	Seaward

**Table A5. Performance Ratings for Composite Piling**

Product	Available Piling size diameter (in)	Stiffness, IE (lb-in <sup>2</sup> )	Relevant Application	Vendor
SEAPILE Composite Marine Piling	10 -16	2.25E +08 - 3.69E +09	Bridge pier protection	Seaward
Composite tubular piling	10 - 24	4.49E+08 -1.34E+10	Bridge pier protection	Hardcore composites

## **RECOMMENDED BRIDGE PIER PROTECTION SYSTEM**

A state-of-the-art bridge pier protection system that will combine Donut Monopile Dolphins, Composite Fender Panels and Composite Piling is suggested (Figure A29). This suggestion is based on the Casco Bay Bridge state-of-the-art bridge pier protection system (Figure A16), with some modifications to improve energy absorption, durability and other desirable characteristics, while keeping the life cycle cost at minimum.

### **System Description**

#### **Donut Monopile Dolphins**

Large donut dolphins provided both upstream and downstream of each bridge pier will absorb all or part of the kinetic energy, and or redirect vessels in danger of colliding with the pier directly (Figure A17).

Dolphins are typically circular cells constructed of driven steel sheet piling, filled with rock or concrete, and topped by a concrete cap. Dolphins may also be constructed of pre-cast concrete sections, or pre-cast entirely off-site and floated into final position. Driven pilings are sometimes incorporated in the cell design. Design procedures for dolphins are usually based on an estimate of the energy changes that take place during the design impact loading. Energy displacement relationships are typically developed for the following energy dissipating mechanisms:

#### ***Crushing of the Vessel's Bow***

- Lifting of the vessel's bow
- Friction between the vessel and the dolphin
- Friction between the vessel and the river bottom
- Sliding of the dolphin
- Rotation of the dolphin
- Deformation of the dolphin

Deformation of the vessel/dolphin system is assumed to follow a path of least energy. For each potential displacement configuration of dolphin and vessel, a deformation path can be developed. Deformation stops when all the kinetic energy of the impact has been absorbed. For the purpose of design, it is recommended that the maximum dolphin deformation be limited to less than one-half of the diameter of the cell. Under design load considerations, the cell is permitted to undergo large plastic deformations and partial collapse.

#### **Composite Pile, Fender and Dolphin Systems**

It has been determined that fender systems will sustain less damage if they consist of vertical pilings only, instead of bracing with battered pilings as per past practice. Provision of a dolphin system all around each bridge pier will provide kinetic energy absorption for vessel impacts at any angle. Hardcore dolphin systems, similar to the one provided at Lewes DE Ferry, have been recommended (Figure A18), as it offers

more superior energy absorption, durability, and other marine features as described below.

### ***Composite Stay-In-Place Formwork***

Hardcore dolphin systems combine composite stay-in-place (SIP) formwork supported on composite monopiles. Hardcore's lightweight, custom SIP formwork allows for rapid installation and protects steel reinforcing elements in the pile cap. These dolphins can be designed for a variety of applications, from mooring and turning dolphins to protecting a bridge pier.

### ***Large Diameter Composite Monopile***

Hardcore is the sole producer of large-diameter composite monopiles available in diameters up to 8' OD and continuous lengths in excess of 100'. A highly durable alternative to either timber dolphins or steel monopiles due to their Fiber Reinforced Plastics (FRP) composite construction, these monopiles exhibit the strength and flexibility to withstand the high-impact energies generated by barges and other vessels.

### ***UHMW – Fender Panels***

Hardcore composite fenders feature an Ultra High Molecular Weight Polyethylene (UHMW PE) wear surface in attractive color schemes. UHMW polyethylene is often referred to as the world's toughest polymer. UHMW is a linear high-density polyethylene, which has high abrasion resistance as well as high impact strength. UHMW is also chemical resistant, has a non-skid surface, and a low coefficient of friction, which makes it highly effective in a variety of applications. This feature makes the hardcore fender panels corrosion-free and lightweight, providing longer service life while eliminating the expense of weight chains. The panels are designed to connect to industry-standard rubber fender elements.

### ***State-of-the-Art Pile Design***

Hardcore composite tubular piling is a cylindrical shell fabricated of high-strength fiber reinforced composite materials. As an option, the outer surface of the shell can be coated with a rubber-toughened acrylic skin. The acrylic skin provides additional protection against abrasion, ultraviolet light, and chemicals (Figure A21).

The inner surface is textured to create a mechanical lock with a filler material, usually concrete. The piling is molded, shipped and driven as a hollow shell and then is filled with concrete or other appropriate core material. If required, the piling can be filled with concrete at the Hardcore Composites factory and shipped as a complete unit. The resulting structure is a piling system with approximately the same stiffness as timber piling, but is 4 times stronger and 15 times more energy absorbent.

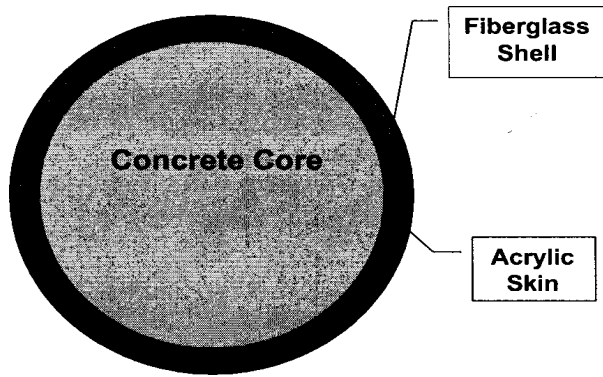

**Figure A21. Concrete-Filled Fiberglass Tubular Piling**

Industry standard driving equipment including diesel, vibratory and drop hammers can be used to install the composite piling. The piling can be driven either open-ended or with a variety of driving shoes. A standard pipe pile driving helmet or equivalent is used in most applications. The piles are easily cut, drilled and attached using ordinary tools found at most job sites. Hardcore Composites fabricates fiberglass tubular piling using Vacuum Assisted Resin Infusion method. This production technique results in less than 0.5% voids in the composite.

***Availability***

Hardcore composite tubular piling is available in standard diameters from 10 to 18 inches in any shippable length. Other sizes are available up to 72 inches in diameter. The standard products are listed in Table A6. Standard composite tubular piling is fabricated using fiberglass. Custom hybrid glass/carbon fiber composite tubular piling that offers higher stiffness is also available. The optional acrylic skin is available in most colors, though the standard color is black.

**Table A6. Standard Composite Tubular Piling**

<b>Product Identification</b>	<b>NOMINAL O.D. (+/- 0.5")in</b>	<b>FRP Shell Thickness (in)</b>	<b>Acrylic Skin Thickness (in)</b>
<b>10-2</b>	10.00	0.182	0.020
<b>12-2</b>	12.75	0.182	0.020
<b>12-3</b>	12.75	0.273	0.020
<b>14-3</b>	14.00	0.273	0.020
<b>18-3</b>	18.00	0.273	0.020
<b>18-4</b>	18.00	0.364	0.020
<b>24-3</b>	24.00	0.273	0.020
<b>24-4</b>	24.00	0.364	0.020

### ***Mechanical Behavior***

The fiberglass tubular piling is designed to resist tensile, compressive, shear and torsion stresses. The concrete filler is also used to carry compressive loads and enhances bending performance. Because of the textured inner surface of the piling, mechanical interlock is developed between the concrete and the composite piling. The resulting hybrid structure can carry both bearing and lateral loads while providing energy absorbing capacity. In general, composite tubular piling has the **compliance of timber**, the **strength of steel** and the **durability of plastic**.

### ***Design Properties***

Concrete filled fiberglass tubular piles are characterized for performance in two ways. The first is by lateral load capacity and the second is by axial load capacity for bearing. Lateral load carrying capacity is determined by flexural testing. Bearing capacity is dependent on the soil properties in which the pile is driven and is typically determined by driving history.

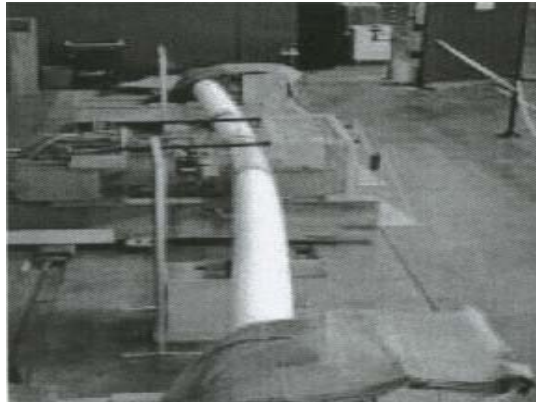

**Figure A22. Three-Point Bending Test**

Flexural testing of the standard Hardcore Composites tubular piling was performed at the ATLSS Multidirectional Laboratory at Lehigh University (Figure A22). Specimens were tested filled with concrete. The nominal concrete strength was 4000 psi. Each specimen was tested in three-point bending test with a 16:1 span to diameter ratio. Load was applied at mid-span. Testing protocol consisted of loading to 25% of predicted maximum deflection at a rate of two inches per minute; return to zero; load to 50% of predicted maximum deflection; return to zero; then finally test to failure. Table A7 lists the ultimate flexural properties of the standard tubular piling.



**Table A7. Flexural Data for Fiberglass Tubular Piling**

Product Identification	Bending Stiffness <sup>1</sup> , EI (lb-in <sup>2</sup> )	Ultimate Bending Moment <sup>2</sup> (in-lb)
10-2	$4.49 \times 10^8$	$1.15 \times 10^6$
12-2	$9.78 \times 10^8$	$2.04 \times 10^6$
12-3	$1.38 \times 10^9$	$2.80 \times 10^6$
14-3	$1.76 \times 10^9$	$3.43 \times 10^6$
18-3	$4.59 \times 10^9$	$5.66 \times 10^6$
18-4	$5.78 \times 10^9$	$7.60 \times 10^6$
24-3*	$1.05 \times 10^{10}$	$1.01 \times 10^7$
24-4*	$1.34 \times 10^{10}$	$1.29 \times 10^7$

<sup>1</sup>Bending stiffness calculated at 20% of ultimate bending moment

<sup>2</sup> In practice, piling should not be used at its ultimate moment capacity. A factor of safety should be used. It is recommended that piling be stressed up to 20% of ultimate moment capacity. The factor of safety may vary at the designer's discretion for particular applications.

\*24 inch diameter pile flexural data based on extrapolation of experimental data.

**Source:** USACERL Technical Report 98/123

Composite tubular piling in bending behaves in a nonlinear fashion. Because of this, it is necessary to define regions in the load/deflection curve to calculate various mechanical properties. Figure A23 shows the locations on the load/deflection curve where the initial, secant and tangent flexural moduli are typically computed. Additional data is available for high load ranges.

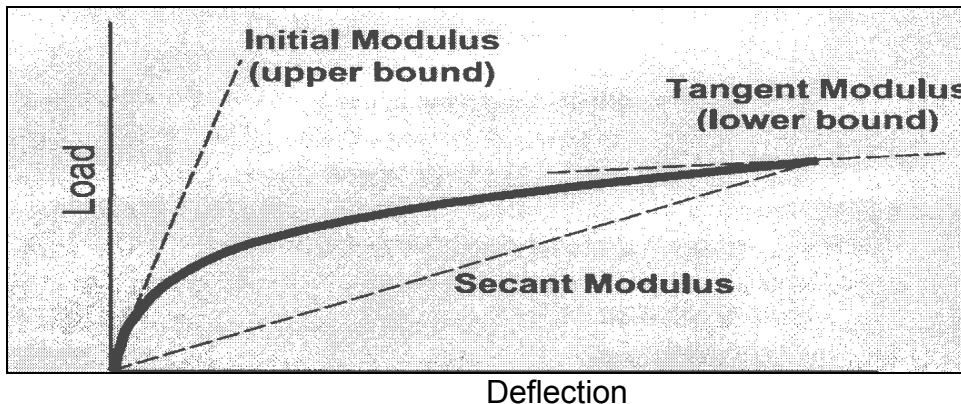

Source : USACERL Technical Report

**Figure A23. Load-Deflection Curve for Fiberglass Piling**

The initial modulus represents the elastic behavior using the "small strain" assumption. The tangent modulus can be defined at any point along the load/deflection curve. The tangent modulus of each standard tubular piling is computed at the maximum load and deflection. Similar to the tangent modulus, the secant modulus can be defined between any two points on the curve.

**Computations for Data Reduction**

The 3-point bending flexural stiffness of the tubular piling is defined by the equation,

$$EI = KL^3/48 \dots\dots\dots(A-1)$$

where: EI = flexural stiffness (lb-in<sup>2</sup>)

K = slope of load/deflection curve (lb/in)

L = span length (in)

A given force (load) is used to calculate the effective 3-point bending moment, M<sub>eff</sub>, at any point in the load/deflection curve.

$$M_{eff} = PL/4 \dots\dots\dots (A-2)$$

where: M = moment (in-lb)

P = load (lb).

Finally, the maximum strain energy is calculated by:

$$U_{max} = (M_{max})^2 / 2EI \dots\dots\dots(A-3)$$

where: U<sub>max</sub> = maximum strain energy (lb)

**Applications**

Typically, piles act as cantilever beams with both axial and lateral loads applied near the top and the base of the pile fixed below the mud line (Figure A24). In most cases, the axial loads on a dolphin are relatively small compared to the lateral loads from collision with vessels or wave action. To further reduce impact forces, Hardcore Composites makes use of composite fender elements. For mooring applications, tubular composite piling can be configured as a single piling dolphin or as a piling cluster. Single pile dolphin construction typically requires large diameter composite tubular piles. Hardcore Composites recommends diameters greater than 24-inches for this purpose.

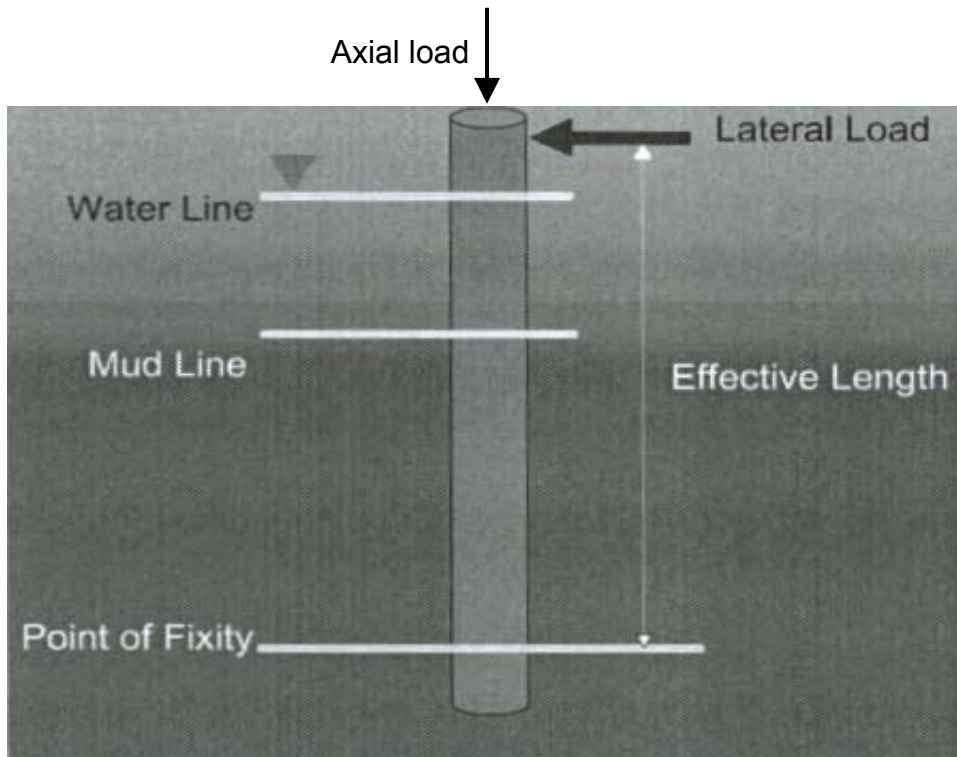

**Figure A24. Composite Piling Applications**

A cluster of smaller piles can also be used to construct a dolphin. Because composite piles have far greater bending capacity than timber piles, fewer composite piles are required for the same structure. Additionally, the overall structure is aesthetically more pleasing and virtually maintenance free.

## DESIGN PROCEDURES

The design of a fender system is based on the law of conservation of energy. The amount of energy being introduced into the system must be determined, and then a means devised to absorb the energy within the force and stress limitations of the ship's hull, the fender, and the pier. Design procedures for a fender system are as follows: <sup>(20)</sup>

- Determine the energy that will be delivered to the pier upon initial impact.
- Determine the energy that can be absorbed by the pier or wharf (distribution of loading must be considered). For structures that are linearly elastic, the energy is one-half the maximum static load level times the amount of deflection. If the structure is exceptionally rigid, it can be assumed to absorb no energy.
- Subtract the energy that the pier will absorb from the effective impact energy of the ship to determine the amount of energy that must be absorbed by the fender.
- Select a fender design capable of absorbing the amount of energy determined above.

### Design Vessel Collision Forces

The selection of the appropriate fender system must be made based on the expected forces to which the fender will be subjected. These forces are due to the possible impact of vessels traveling in the water channel. To determine the magnitude of these design forces, AASHTO developed the Guide Specifications and Commentary for Vessel Collision Design of Highway Bridges <sup>(20)</sup> that was later incorporated into the AASHTO LRFD Bridge Design Specifications. Because absolute safety is impossible to reach due to the large number of uncertainties associated with predicting the vessel impact forces, the AASHTO requirements are based on the probability of bridge collapse that can be calculated using factors related to the site where the bridge is located. The purpose of applying a fender system is to avoid such collapses. Hence, the force that the fender should be able to resist must be equal to the impact design force as specified by the AASHTO procedure.

The factors that influence vessel impact forces include the weight, size, and speed of the barges traveling the waterway where the bridge is located as well as the geometry of the waterway. According to AASHTO LRFD Specifications, the acceptable annual frequency of collapse is 0.0001 for critical bridges and 0.001 for other bridges. Specifically, the AASHTO LRFD specification stipulates that the probability of collapse should be calculated based on the number of vessels, the probability of vessel aberrancy, the geometric probability of collision given an aberrant vessel, and the probability of a bridge collapse given a collision. The AASHTO LRFD specification provides an empirical equation to obtain the probability of bridge collapse given that a collision has occurred. The design force to avoid the prescribed probability of collapse is then obtained. Conservative assumptions are implicitly included in many of the empirical equations used in the safety check process (e.g., estimation of barge impact force), in effect, further reducing the probability of collapse. This section of the report

reviews the basis behind the AASHTO Specifications that determine the design impact force that should be used to select the proper fender system.

### **VESSEL COLLISION FORCES**

Considerable effort was spent on studying vessel collision forces during the development of the AASHTO Guide Specifications for Vessel Collision Design of Highway Bridges (1991).<sup>(20)</sup> The AASHTO Guide uses a reliability-based formulation following the recommendations made by several International Association for Bridge and Structural Engineers (IABSE) workshops and symposia. The reason for following a reliability-based approach is to account for the large number of uncertainties associated with estimating the actual impact forces and to ensure compatibility with other design criteria (namely the whole set of LRFD Specifications). An IABSE Working Group assembled a state-of-the art report summarizing the findings of an international group of researchers. This document gives an overview of the background information that led to the development of the AASHTO Guide Specifications. The Guide gives an example outlining the application of the Guide’s Method II that gives the probability-based analysis procedure for determining the design forces due to ship impacts with bridges. In addition, Whitney et al.<sup>(24)</sup> describe the application of the AASHTO vessel collision model for barge traffic over the Ohio River. The calculations require site-specific information because bridges spanning waterways are normally subjected to unique conditions and should be studied on an individual basis.

Based on the AASHTO Guide method, the design barge collision force can be represented by an empirically derived equation as a function of the barge bow damage depth. The design force equation takes the form:

$$P_B = 60a_B \quad \text{for } a_B < 0.1\text{m} \quad \dots\dots\dots (A-4)$$

$$P_B = 6 + 1.6a_B \quad \text{for } a_B \geq 0.1\text{m} \quad \dots\dots\dots (A-5)$$

where:

- $P_B$  is the nominal design force in MN (Mega-Newtons), and
- $a_B$  is the barge bow damage depth.

According to the AASHTO Guide Specifications, the barge bow depth is calculated from the kinetic energy of the moving barge. When barges in large rivers travel in flotillas, the kinetic energy that should be used in calculating the collision force should account for the masses of all the barges in one column of the flotilla when head-on collisions are considered. Hence, the kinetic energy, KE, is calculated as:

$$KE = \frac{C_H W V^2}{2 \times 9.81} \quad \dots\dots\dots (A-6)$$

where:

- $W$  is the weight of a flotilla column;
- $V$  is the speed of the flotilla at impact, and 9.81 is the acceleration due to gravity in  $m/s^2$ ; and
- $C_H$  is a hydrodynamic coefficient that accounts for the effect of the surrounding water upon the moving vessel.

As an example, Whitney et al.<sup>(24)</sup> suggest that the value  $C_H=1.05$  is appropriate for the Ohio River because of the relatively large under keel clearance and accelerations in the direction of the ship length (i.e. no large lateral motions as those associated with barge berthing). The barge damage depth,  $a_B$ , is given as:

$$a_B = \frac{[\sqrt{1.00 + 0.13KE} - 1]x3.1}{R_B} \dots\dots\dots (A-7)$$

where  $R_B$  is the correction factor for barge width given as  $R_B=B_B/10.68$ , with  $B_B$  being the barge width in meters (or  $R_B=B_B/35$  in feet for U.S. units). The correction factor is meant to account for the difference between the width of the barge tested to empirically obtain the barge damage depth equation and the barge width of the impacting vessel.

The kinetic energy of Equation (2) must be calculated based on the speed at impact that must account for the speed of the flotilla relative to the river and the river flow speed. When the main piers of a bridge are adjacent to the vessel transit path, the transit speed is used for the relative speed of impact. Otherwise, AASHTO gives an empirical equation that describes how the speed varies with the travel speed to the river flow speed as a function of the distance between the transit path and the pier location. For example, Whitney et. al. (1996) found that the flotilla speed in the Ohio River may reach up to 3.13 m/sec (10.3 feet/sec). Given that the river speed is on the average 1.86m/sec (6.1 feet/sec), the speed at impact will be equal to 4.99 m/sec (16.4 ft/sec).

**Modeling Factor**

Equation 1 for the nominal impact force was developed based on experimental data of individual barge collisions with lock entrance structures and bridge piers. These studies included dynamic loading with a pendulum hammer, static loading on barge models, as well as numerical computations. However, the tests were conducted for single barges at low velocities and not multi-barge flotillas traveling at high velocities. Whitney et al.<sup>(24)</sup> report that the actual crushing depths, as observed from accidents on the Ohio River were much lower than those calculated from the results of the AASHTO equations. This may be due to the significant energy loss that occurs between the barges of the flotilla due to friction and crushing. To correct for the differences between the calculated damage and the observed damage, the AASHTO Guide uses a modeling variable  $x$ . Thus, the actual impact force is given as:

$$P = xP_B \dots\dots\dots (A-8)$$

where:

- $x$  is the modeling variable; and
- $P_B$  is the predicted value of the impact force, given by Equation 1.

The random variable,  $x$ , gives the ratio of the actual impact force  $P$  to the nominal impact force  $P_B$ . A probability density and a cumulative distribution function are given to describe  $x$  as shown in Figure A25 (adapted from Figure C4.8.3.4-2 of the AASHTO Guide). For a given value of barge weights in a flotilla column,  $W$ ,  $P_B$  is calculated from Equations 1 through 3. The probability that  $P$  is greater than a certain fraction of  $P_B$  is obtained from Figure A25b. Figure A25 shows that  $P_B$  gives a very conservative estimate of the impact force. For example, Figure A25b shows that the probability that  $P$  is greater than  $0.1P_B$  (or  $x=P/P_B=0.1$ ) is only 0.1 (or 10%). The probability that  $P$  is greater than  $0.5P_B$  (or  $P/P_B=0.5$ ) is 0.0556 (or 5.56%). The probability that  $P$  is greater than  $P_B$  ( $P/P_B=1$ ) is zero. The AASHTO Guide states that the results illustrated in Figure A25 were obtained from an unpublished report by Cowiconsult (1987) for ship collisions. The same curve was assumed by Whitney et al. to be valid for collisions of barge flotillas.

**Rate of Collisions**

Equation 4 gives the force at impact given that a barge column with a known weight and speed has collided with a bridge pier. However, since not all flotillas are expected to collide, the reliability calculations must account for the number of collisions expected during the design life of the bridge structure. The AASHTO Guide Specifications develop the design criteria in terms of annual risk.

As presented in the AASHTO guide specifications and the IABSE Report, the annual failure rate due to vessel collisions,  $AF$ , can be expressed as:

$$AF = \sum_i O_i N_i P_{A_i} \sum_k P_{G_{i,k}} P_{C_{i,k}} \dots \dots \dots (A-9)$$

where:

- $N_i$  is the number of vessels (or flotillas) of type  $i$  that cross the waterway under the bridge in one year;
- $P_{A_i}$  is the probability of vessel aberrancy (of straying away from normal navigation channel) for vessels of type  $i$ ;
- $P_{G_{i,k}}$  is the geometric probability of collision of ship type  $i$  with bridge element  $k$  (this gives the probability of having a collision with bridge member  $k$ , given that an aberrancy occurred in ship or a flotilla of type  $i$ ); and
- $P_{C_{i,k}}$  is the probability that the bridge will collapse given that a vessel of type  $i$  has collided with member  $k$  of the bridge.

Equation (5) leads to the yearly rate of collisions for each vessel (or flotilla) of type,  $i$ , into a particular bridge element,  $k$ , as:

$$O_i = N_i PA_i PG_i, \dots\dots\dots (A-10).$$

Below is a description of the method proposed by the AASHTO Guide to calculate the probability of aberrancy and the geometric probability.

**Probability of Aberrancy, PA**

The probability of aberrancy (sometimes referred to as the causation probability) is a measure of the risk of a vessel losing control as a result of pilot error, adverse environmental conditions, or mechanical failure. The AASHTO Guide states that the evaluation of accident statistics indicates that human error (causing 60 to 85 percent of the aberrancy cases) and environmental conditions form the primary reasons for accidents. The environmental causes include poor visibility, strong currents, winds and channel alignment. The IABSE Report states that statistical data in major waterways show that the probability of vessel aberrancy varies from about 0.5 to 7 in 10,000 passages. Worldwide, the average is about 0.5 in 10,000 passages. Since such data is hard to obtain, particularly for new bridge sites, the AASHTO Guide proposes an empirical equation based on historical accident data. The equation (Eq. 4.8.3.2-1 in the AASHTO Guide) accounts for the following factors:

- geometry of the navigation channel and the location of the bridge in the channel (turns and bends);
- current direction and speed;
- cross-currents; and
- vessel traffic density,

and is given as:

$$PA=BR_a (R_B)(R_C)(R_{XC})(R_D) \dots\dots\dots (A-11)$$

where:

- PA=Probability of aberrancy;
- BR<sub>a</sub>=aberrancy base rate = 0.6x10<sup>-4</sup> for ships or 1.2x10<sup>-4</sup> for barges;
- R<sub>B</sub>=correction factor for bridge location=1.0 for straight paths regions (varies as function of angle θ for vessel paths with turns and bends);
- R<sub>C</sub>= correction factor for current acting parallel to vessel path;
- R<sub>xc</sub>=correction factor for crosscurrents acting perpendicular to vessel transit path; and
- R<sub>D</sub>=correction factor for vessel traffic density depending on the frequency of vessels meeting, passing or overtaking each other in the immediate vicinity of the bridge.



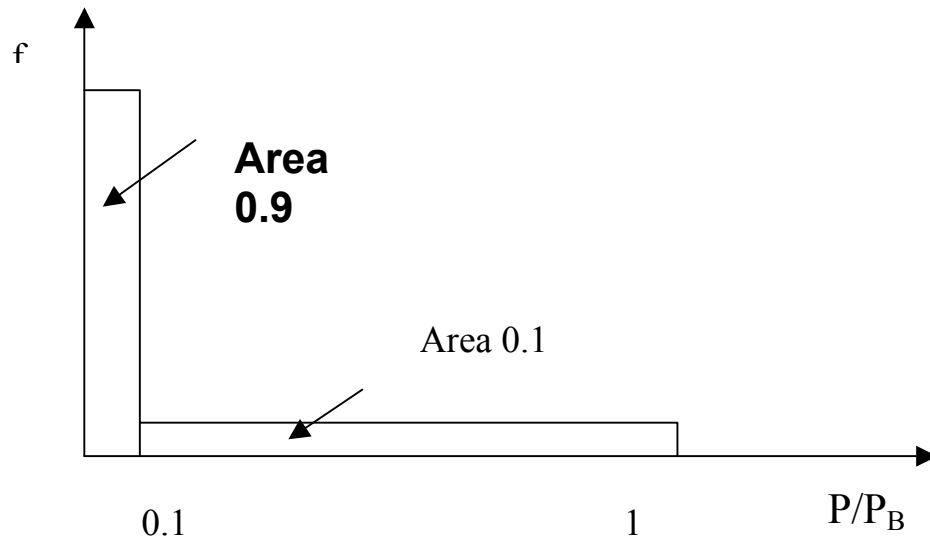

(a) Probability density function for relative magnitude of the collision force,  $x$

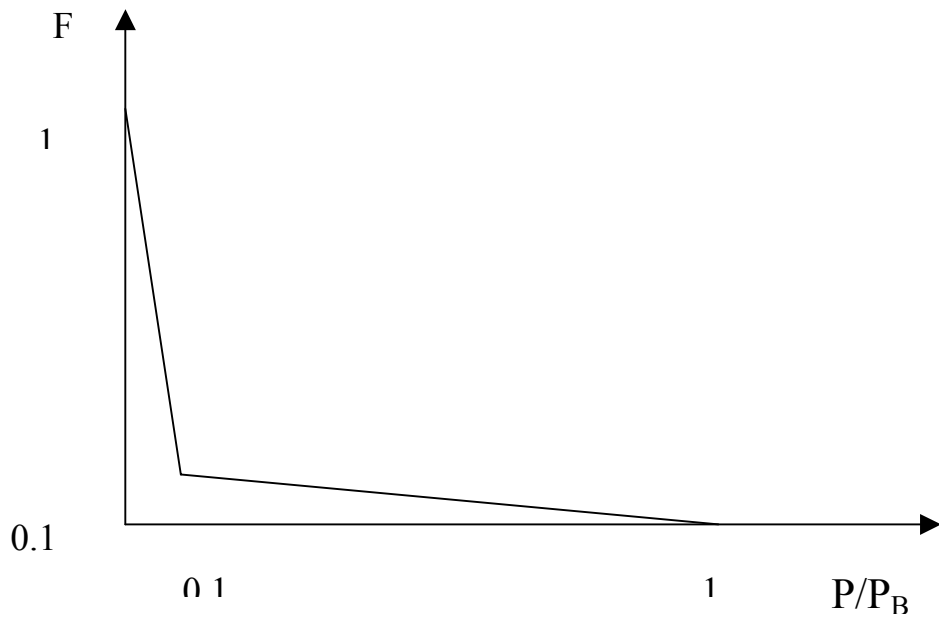

(b) Distribution function for  $x=P/P_B$  exceeding a given level

**Figure A25. Distribution Function for Vessel Collision Forces**

For example, the actual data collected by Whitney et al.<sup>(24)</sup> for barge collisions in the Ohio River shows that the rate of aberrancy has an average value of  $5.29 \times 10^{-4}$  which is higher than the  $1.20 \times 10^{-4}$  AASHTO value. They also found that the rate of aberrancy was equal to  $13.78 \times 10^{-4}$  for the Tennessee River,  $18.11 \times 10^{-4}$  for the Cumberland River,  $3.14 \times 10^{-4}$  for the Green River and  $1.2 \times 10^{-4}$  for the Kentucky River. The IABSE report indicates that the probability of collision with bridge piers increases by a factor of 3 when the wind speeds are in the range of 40 to 50 km/hr (25 to 30 mph) as compared to the aberrancy rates when the wind speeds are 20 to 30 km/hr (12 to 19 mph).

### ***Geometric Probability, PGI***

The geometric probability is defined as the probability of a vessel hitting the bridge pier given that the vessel has lost control. This probability is a function of many parameters including the geometry of the waterway, location of bridge piers, the characteristics of the vessel, etc. The AASHTO Guide Specification has developed an empirical approach for finding the geometric probability. The AASHTO approach is based on the following assumptions:

- The lateral position of a vessel in the waterway follows a normal distribution with a mean value centered on the required path line (centerline of navigation route).
- The standard deviation of the lateral position distribution is equal to the overall length of vessel, designated as LOA. In the case of flotillas, Whitney et al. recommends using the total length of the flotilla (i.e., barge length times number of barges in a column).
- The geometric probability is calculated from the normal distribution depending on the location of the pier relative to the centerline of the navigation route, the width and orientation of the pier, and the width of the vessel. For flotillas, the total width of the flotilla should be used.

The method to calculate the geometric probability, PG, is illustrated in Figure A26, as adopted from the AASHTO Guide and the IABSE Report. The use of a standard deviation equal to LOA was justified based on accident data to reflect the influence of the size of the colliding ship.

### ***Probability Distribution of the Predicted Impact Force, PB***

The force  $P_B$  of Equation (1) depends on the type of impacting vessel (or flotilla) including the weight of the vessel, its length, and other geometric features. When given the statistical data on the types of vessels (or flotillas) and their properties, the probability distribution of the predicted impacting force  $P_B$  can be assembled. Data on the type of vessels and their weights can be gathered from agencies that track the traffic in U.S. waterways such as the U.S. Army Corps of Engineers. For example, the corps has provided data on barge traffic in the Mississippi River near Memphis, Tennessee. Figure A26 shows the yearly probability distribution function for the impacting force calculated for the Mississippi River based on this Corps of Engineers' data.

The AASHTO Guide specifies that when a vessel collides with a bridge pier, the impact force,  $P_B$ , obtained from Equation 1, will be applied as a concentrated force at the high water level.

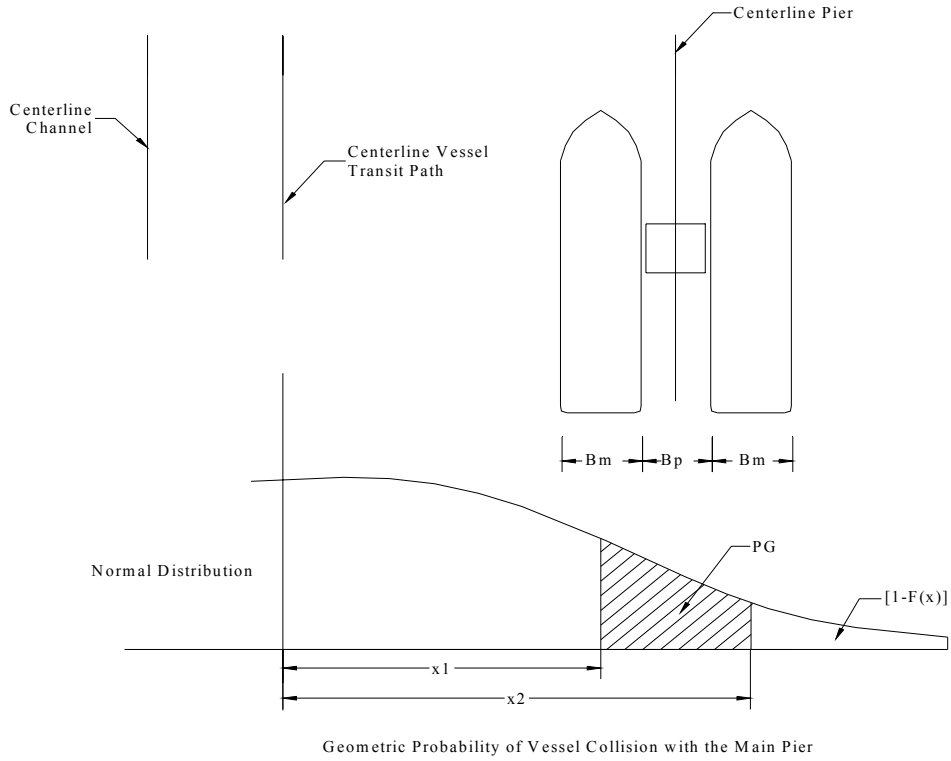
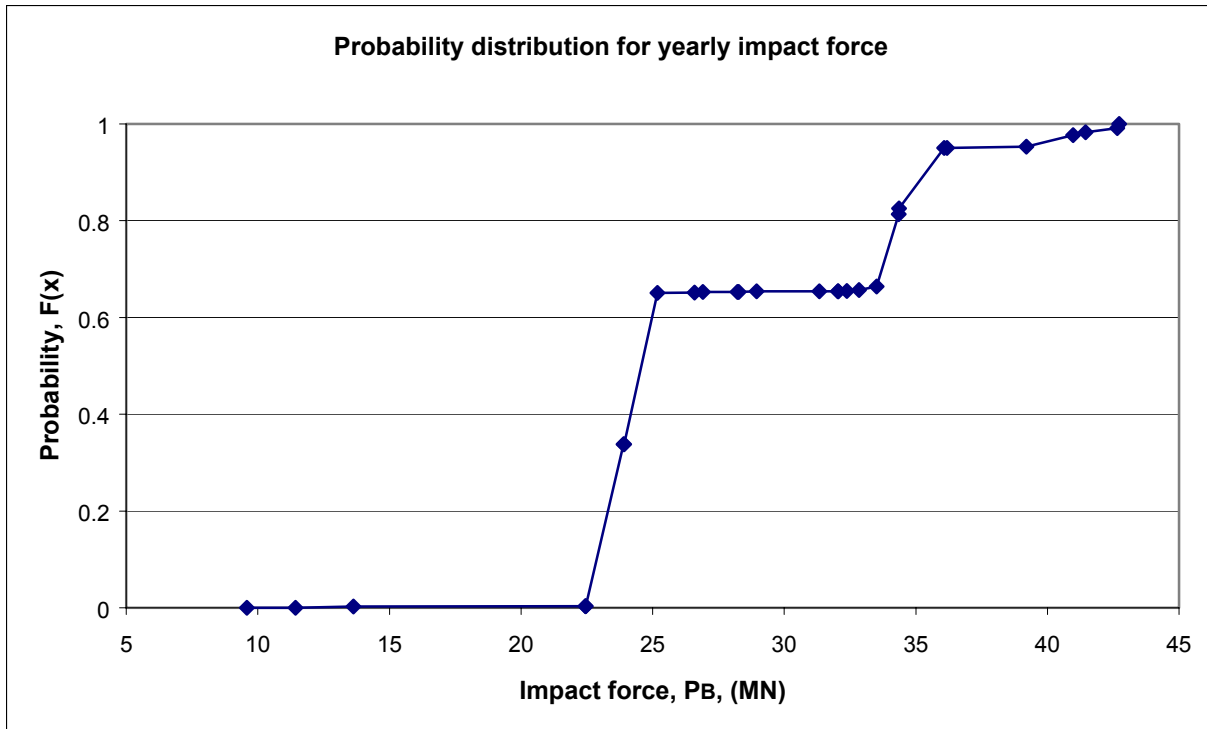

**Figure A26. Probability of Vehicle Collision Model**  
 [Based on the AASHTO Guide (1991) and Larsen (1993)]

## Summary

The AASHTO model to estimate the impact force for bridge piers subjected to vessel collisions consists of the following steps and assumptions:

- The geometric probability,  $PG_i$ , of a vessel or flotilla type  $i$  colliding with the bridge pier depends on the flotilla overall length,  $LOA_i$ , as described in Figure A26. Each flotilla of type  $i$  may have a different length depending on the number of barges in each column and the length of each barge. This information is collected for each waterway depending on the type of vessel traffic.
- The expected number of collisions of vessels (or flotillas) of type  $i$  with the pier is equal to  $N_iPA_iPG_i$ , where  $N_i$  is the number of flotillas of type  $i$  crossing the site;  $PA_i$  is the probability of aberrancy of flotilla type  $i$ ; and  $PG_i$  is the geometric probability of collision of flotilla type  $i$ .
- The nominal force applied to the pier, if a flotilla of type  $i$  collides with the bridge pier, is calculated from Equation 3, when the total weight of the flotilla and the width of the impacting barge are known. Each flotilla of type  $i$  may have a different total weight depending on the number of barges in the flotilla and the weight of each barge. Whitney et al.<sup>(24)</sup> uses the weight of one column of barges to find the kinetic energy at impact. The assumption is that the other columns are loosely tied to the impacting column in such a way that at impact only the barges in one column will contribute to the impact energy.
- By assembling the nominal “average” impact force for each flotilla type and the expected number of collisions for each flotilla type, a cumulative distribution of the yearly impact force can be drawn, as shown in Figure A27.
- The final design force is obtained from Figure A27 by satisfying the annual probability of collapse as specified by AASHTO for critical bridges or other types of bridges. This design force is assumed to be distributed over damage depth that is calculated as shown in Equation (3).
- The fender system is selected to resist the impacting force when distributed over the vessel damage area.



**Figure A27. Cumulative Distribution Function for Ship Collision**

**Design Example (Appendix 2)**

The example given illustrates the application of the AASHTO guide specification<sup>(20)</sup> to determine the magnitude of the vessel or bridge impact force against which bridge piers are 100% protected. For illustrative purposes, this example utilizes barge traffic data from Ohio River at Maysville, Kentucky.<sup>(24)</sup>

The results indicate that the "design flotilla," or flotilla category, for which the probability of collapse equals zero (i.e., the lateral capacity of bridge fenders at the impact location equals the flotilla equivalent static impact load) is category CC. The lateral capacity of the bridge required for the bridge pier should not be less than [31.89 MN (7,170 kips)]. With frequency of collapse set at zero, lateral capacity requirements can be transferred to the fender piles or pile groups and dolphins.

**Energy to be Absorbed by the Pier**

Given the project objective of developing a 100% energy absorbing fender system, the piers are assumed to absorb no energy.

**Energy that Must be Absorbed by the Fender**

Since the piers are assumed to absorb no energy, fenders must absorb 100% of the energy.

## **Fender Selection**

Laboratory testing of mechanical properties showed that composite fender piles are viable substitutes for wood, steel and pre-stressed concrete fender piles.<sup>(25)</sup> While there are many other important properties, the two most important properties of fender piles are EI (bending stiffness) and radial compression (pinch). An example to illustrate preliminary fender selection by using the information given in the previous sections is provided in Appendix 3.

## **Specification Guide**

Test methods and materials standards for the various pile systems are being developed and tested under a Construction Productivity Advancement Research Program (**CPAR**) project.<sup>(25)</sup> Currently they are being addressed by an ASTM Committee Section D20.20.04 on Systems for Marine/Waterfront Applications. The diversity of the different products presents a challenge in developing a universal composite piling specification. Until ASTM, or other appropriate industry consensus standards organization meets this challenge, the following "Specification Guide" information is presented to assist the design engineer in developing his/her own specification or assuring that a manufacturer's specification covers the most critical items.

### ***Specifications for Fender Piles***

1. Check required cross-sectional dimensions noting upper and lower limits and any shape restrictions.
2. Check required total pile length and whether spliced sections are allowed.
3. EI determined experimentally using ASTM test method (currently under development). Until this method is completed, the test shall be conducted in a three-point bending mode on a full-sized pile specimen with an appropriate L:D ratio (Figure A22). If splices are allowed, a test must be conducted to show that the spliced section has properties equal to or greater than the unspliced section. To avoid brittle behavior, the outer fiber strain shall be two percent or greater at failure.
4. If the fender pile is to be used in a design where the pile is subject to a pinching action, determine the radial compressive properties per ASTM (method currently under development). Until this method is completed, suggest conducting a stress-strain test perpendicular to the pile axis at -40 °F at a strain rate of 100 percent per minute.
5. State if any special handling requirements are necessary due to the design or composition of the pile.
6. List any special techniques or fixtures required to drive the pile.
7. Detail fastening and joining methods, especially if certain restrictions or limitations apply. If such special requirements apply, the pile should be so labeled. List and describe any special hardware needs.
8. The materials composition of the pile shall not pose a hazard to the environment through any leaching action

Table A8 shows five different fender pile designs/products from manufacturers who participated in the CPAR Laboratory evaluation program.

**Table A8. Composite Pile Manufacturers**

<b>Manufacturer</b>	<b>Fender</b>
Creative Pultrusions, Inc.	Glass fiber reinforced thermoset polymer matrix, tic-tac-toe profile with HDPE cover
Hardcore Dupont Composites, LLC	Concrete filled and unfilled, glass fiber reinforced thermoset polymer matrix tubes
Lancaster Composite, Inc.	Concrete filled, filament wound, glass fiber reinforced thermoset polymer matrix tube
Seaward International, Inc.	HDPE reinforced with glass fiber reinforced polymer composite rebars
Trimax of Long Island, Inc.	HDPE reinforced with chopped glass fibers

Laboratory tests concluded that the Hardcore Dupont and the Lancaster Composite piles, as submitted for the bending tests, are similar in that they are both fiber-reinforced polymer composite tubes filled with concrete. However, the composition and the fabrication methods used to produce the tubes (or stay-in-place-forms) are completely different from each other. Likewise, the concrete formulations used by each manufacturer are also very different. Hardcore Dupont pile had higher stiffness values as compared to the Lancaster Composite pile.

***Selection Considerations***

Due to variations in material composition and design, each of the fender composite piles has its own unique properties. Given appropriate considerations in the design of the structure, any of these composite piles can be used as a fender pile. Some of the considerations include:

1. The amount of the impact energy to be absorbed;
2. The geometry of the pier structure and whether the mode of loading is more or less in a radial compression (pinch) mode or a bending mode,
3. Average temperature and expected temperature extremes; and
4. The use or absence of camels (which spread the load over several piles) as well as other auxiliary bumpers.

Finally, the structural design engineer is then responsible for selecting the fender pile type and design that will best work with the structure, considering total structure

function, performance, and project budgets (see Appendix 3 for a preliminary fender selection example).

## **LIFE CYCLE COST ANALYSIS**

Any protection system selected to protect a bridge pier structure will affect both the safety and economics of that structure for the rest of the structure's life. To select among various competing fender system alternatives, life cycle cost analysis for six generic alternatives, based on the use of materials of differing cost for the basic protection system structure, was considered as follows:

ALTERNATIVE A: No Protection System

ALTERNATIVE B: Steel Piles

ALTERNATIVE C: Timber Piles

ALTERNATIVE D: Concrete Piles

ALTERNATIVE E: Rubber Fender Systems (Rubber in compression /in-shear)

ALTERNATIVE F: Composite Fender Systems (Hardcore composites, UHMW fender panels)

## **LCCA Spreadsheets for Fender System Alternatives**

An LCCA spreadsheet model was developed to analyze the six generic alternatives, as follows:

1. Sheet 1: Lists basic assumptions regarding structural characteristics, unit costs of materials, frequency of collisions, repair and rehabilitation strategies, lane rental fees, accident costs, analysis period and discount rate.
2. Sheet 2: Lists default data for computation of agency costs, including environmental cleanup, and user costs, including accident and delay costs.
3. Sheets 3-8: Presents LCCA computations for alternatives A-F, respectively, delineating agency costs from user costs, with agency costs further delineating NJDOT from other agency (ship/barge repairs and environmental cleanup) costs.
4. Sheet 9: Presents a summary of results, with alternatives arrayed in ascending order of total LCC, while showing the allocation of those costs to the agency, user and "others".

All input data can be varied from Sheet 2 to reflect the particularities of any environment, with the exception of the repair and rehabilitation schedules, which can only be varied in Sheets 3-8. Any variation of the input data can be monitored from the summary Sheet 9, in which default values are represented for comparison. The LCCA spreadsheets may be accessed and manipulated by double clicking on the XLS icon in Figure A28.



(Double click the xls icon below for the table/see overleaf).

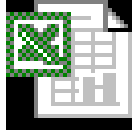

**LCCA-SPREAD  
SHEET.xls**

**Figure A28. Spreadsheet for LCCA for Fender Systems**

**Results of LCCA (Default Values):**

The results of the LCCA are shown in Table A9. **ALTERNATIVE F** has the lowest total life cycle cost at \$261.06 million. It should be noted, however, that Alternative B would represent the lowest agency (NJDOT) life cycle cost. In this case, ship/barge repairs and environmental cleanup would account for almost all of the difference. This would suggest that “other agencies” could be persuaded to jointly finance the cost of the more agency-costly alternatives. The high agency cost for Alternative A would be for repair and rehabilitation for the unfendered piers and bridge structures. Note also that with composite piling (Alternative F), the costs of ship/barge impacts would be negligible.

**Table A9. Results of LCCA for Generic Bridge Pier Fender Systems**

<b>Alternatives</b>	<b>Total Costs</b>	<b>Agency Costs</b>	<b>User Costs</b>	<b>Other Costs</b>
<b>F: Composite</b>	<b>261.06</b>	261.06	0.00	0.00
<b>E: Plastic/Rubber</b>	<b>342.90</b>	241.09	36.70	65.11
<b>D: Concrete</b>	<b>441.24</b>	239.50	173.10	28.65
<b>B: Steel</b>	<b>488.76</b>	<b>215.22</b>	247.28	26.25
<b>C: Timber</b>	<b>574.10</b>	368.73	103.03	102.33
<b>A: None</b>	<b>1119.90</b>	529.71	329.71	260.47

- Note: 1. Life cycle costs in millions.  
 2. Agency costs include construction, maintenance, repair and rehabilitation costs.  
 3. User costs include accident and delay costs.  
 4. Other (agency) costs include ship/barge repairs and environmental cleanup costs.

## DISCUSSIONS ON THE RECOMMENDED SYSTEM

### Life Cycle Cost

From the above life cycle cost analysis it is evident that the costs of repairing bridge damage, and the costs of performing fender/bridge maintenance, if an inadequate protection system is used, are potentially much greater than the entire cost of the adequate protection system in the first place.

Although dynamic performance is the obvious key-identifying attribute of marine fenders, a fender system must remain functional for an extended period to provide protection commensurate with the value of the structure being protected, and the cost of the fender. The life of a fender system is determined by a complex interrelationship between many variables. Among the issues that affect it are:

- Rubber ages due to oxidation and/or ozone attacks. Eventually, all rubber, that does not fail due to catastrophic overload, will fail due to embrittlement by either oxygen or ozone attack.
- All carbon steel will eventually fail due to corrosion. This can be protected by either impervious or sacrificial layers, but eventually these layers will be damaged, or significantly consumed so that the steel will be corroded.
- All plastics are embrittled by ultraviolet radiation. No plastics are protected against ultraviolet radiation attack, unless specifically required to be so. Without protection, plastic exposed to sunlight will usually fail in less than five years, sometimes less than two years.
- The size, shape, and/or contour of vessels make some vessels very easy to fender, and others very difficult. Certain generic types of fenders will not survive if asked to fender some types of vessel. Among the most difficult vessels suitable for fendering are barges and small ferries. Among the easiest are large tankers. Consequently, when fendering the more problematic vessels, the physical shape and contour of the fender's contact surfaces are critical to its long-term survivability and maintenance requirements.
- Fender pitch, the spacing between successive fenders, is defined absolutely by the shapes of the vessels berthing against the fenders. Fenders can be spaced more closely with few significant disadvantages other than increased cost.
- The effective coefficient of friction of the fender contact surface against a vessel's hull largely determines the impact on the vessels hull. Lower coefficients of friction allow vessels to glide without damage to the hull.

Based on the issues discussed above and the results of Life Cycle Cost Analysis, a fender system of **HARDCORE COMPOSITE PILE DOLPHINS, COMPOSITE TUBULAR PILES WITH STAY-IN-PLACE FORMWORK SURROUNDED BY COMPOSITE UHMW FACED FENDER PANELS** was cited as the most cost effective

alternative state-of-the-art fender system. This system will offer not only the lowest life cycle cost, but also other benefits as presented below.

### **Energy Absorption Capabilities**

The superior strain energy capability of composite materials means that additional kinetic energy can be absorbed by the composite monopile. Composite piling systems with approximately the same stiffness as timber piling is 4 times stronger, and 15 times more energy absorbent.<sup>(23)</sup>

### **Other Benefits**

The use of composite materials offers significant durability benefits over traditional timber, steel and concrete because they are:

- Highly corrosion resistant.
- Not affected by marine borers.
- Not affected by adverse weather.
- Impervious to water.
- Resistant to rot or rust.
- Resistant to ultraviolet light.

The use of Ultra High Molecular Weight (UHMW) for the fender panel surface offers additional durability benefits because UHMW:

- Is about six times more abrasion resistant than steel.
- Is virtually unbreakable with no notch sensitivity.
- Is non-marking and nonabrasive.
- Is has a low friction coefficient making it slick in any weather.
- Is available with a non-skid surface where traction is needed.
- Is lightweight, easy to transport and install (1" x 12" x 12" = 5 pounds).
- Has no cold embitterment; works from -155°F to + 200°F.
- Can be cold or heat bent to meet required shapes.
- Requires virtually no maintenance.
- Is nonconductive, nonmagnetic, and non-fibrous.
- Absorbs no water and is impervious to most chemicals.
- Does not chip, peel, crack, or rot.
- Is impervious to marine borers and resistant to barnacles.
- Is environmentally friendly, containing no harsh chemicals.
- Can be custom-colored.
- Has low construction costs.

Composite monopile and fender panes are lighter in weight than the traditional timber, steel, and concrete and therefore offer benefits for ease of fabrication, transportation and installation.

## RECOMMENDATIONS

A protection system composed of **HARDCORE COMPOSITE PILE DOLPHINS, COMPOSITE TUBULAR PILES WITH STAY-IN-PLACE FORMWORK SURROUNDED BY COMPOSITE UHMW FACED FENDER PANELS** (conceptual diagram, Figure A29) is recommended as a state-of-the-art bridge pier protection system for NJDOT. This recommendation was achieved by rating from best to worst, six design alternatives based on their life cycle cost. Furthermore, the nature of composite materials, will allow this system to:

- Have superior energy absorbing capabilities.
- Preserve the value of the entire bridge by preventing destruction by marine vessels.
- Prevent severe destruction of the vessel, and therefore reducing vessel maintenance costs and the costs to clean up the environment in case of oil or chemical spillage.
- Minimize maintenance costs, as it will virtually require no major maintenance for its entire design life.

An existing example is that of Casco Bay Bridge in Portland Maine. About \$7 million was spent on a similar state-of-the-art protection system around all the piers, to protect a \$130 million bridge. This system was able to absorb the impact and prevent damage to the bridge pier, bridge, and the vessel, in May 2002, when a 685-foot oil tanker transporting 11.3 million gallons of fuel struck the bridge fender system. Only about \$1 million was needed to repair the fender system after the impact.

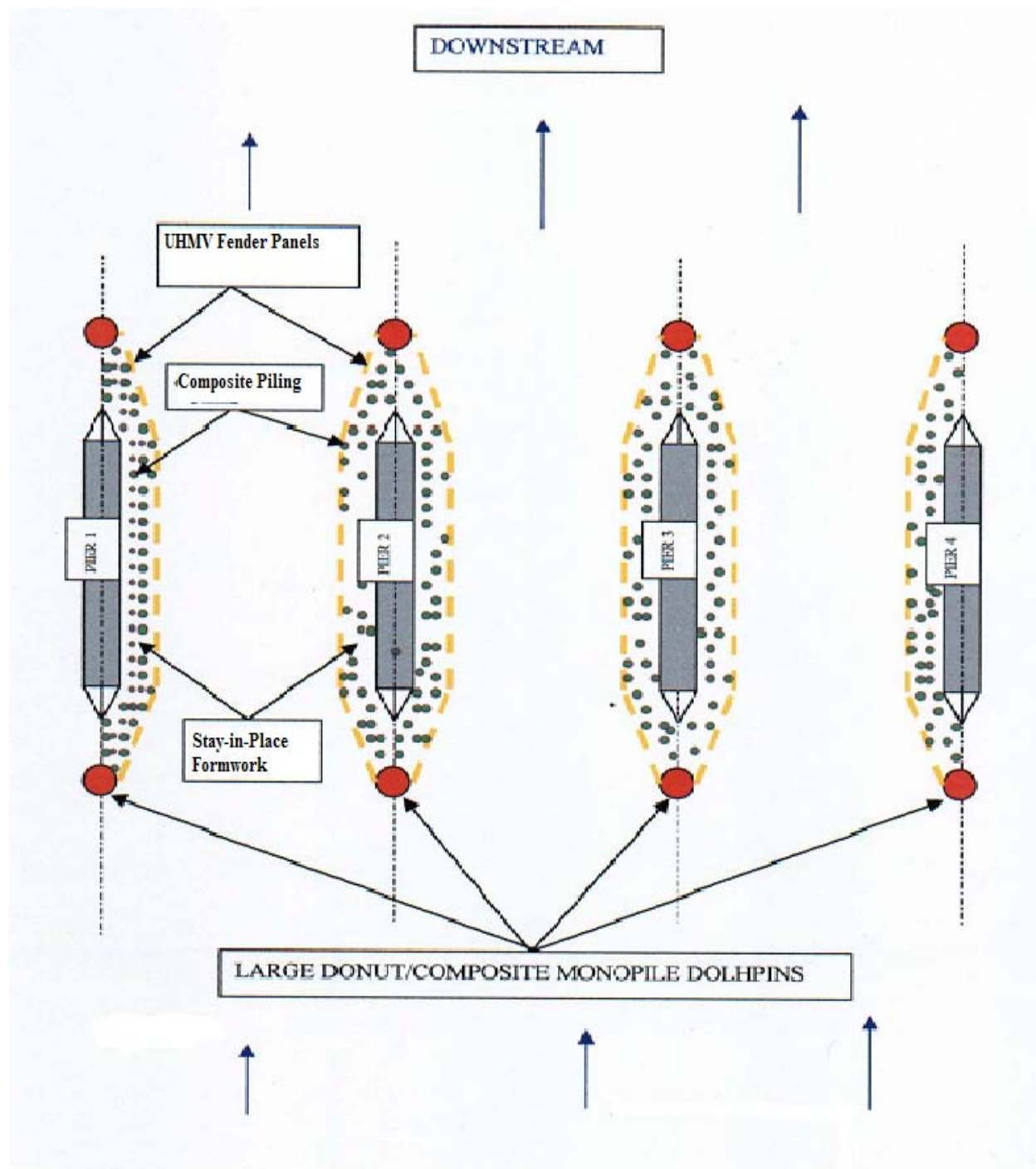

Figure A29. Recommended Fender System (Conceptual Diagram)

## REFERENCES

1. "Synthesis Report on Extreme Loading Conditions," FHWA (1996), 178 pages.
2. Wuttrich, R, Wekezer, J., Yazdani, N., and Wilson, C., (2001), "Performance Evaluation of Existing Bridge Fenders for Ship Impact," ASCE, J. of Constructed Facilities, V. 15, Issue 1, pp.17-23.
3. Yazdani, N., Wuttrich, R, Wekezer, J., and Wilson, C. (2000), " Investigation of Fender Systems for Vessel Impact," Report No. 1902-137-11, Florida Department of Transportation, Final Report, 143 pages.
4. Patev, R.C., (1999), " Full-Scale Barge Impact Experiments," Transportation Research Circular, Issue 491, pp. 36-42.
5. Permanent International Association of Navigation Congresses (PIANC) "Report of the International Commission for Improving the Design of Fender Systems", Brussels, Belgium, 1984.
6. Pardon, D.V., (1986), " Marine Fender Systems: Planning for Effective Design and Construction," Journal of Dredging & Port Construction, V. 13, No. 6, pp. 123-128.
7. "Fender Manufacturers-Expanding Range and Capacity"(1980). Cargo Systems International, V.7, Issue 7, 89 pages.
8. "Advanced Pier Concepts Users Guide" (1985). Report NCEL-UG-0007, Naval Civil Engineering Laboratory, 368 pages.
9. U.S. Coast Guard, "Bridge Protection Systems and Devices – Final Report". U.S.C.G. Office of Navigation, Report No. CG-N-1-81, 1981.
10. Derucher, K.N., and Heins, C.P. (1980), " Bridge and Pier Protective Devices and Systems," Transportation Research Record, Issue 785, pp 6-14.
11. Derucher, K.N., and Heins, C.P. (1979), " Bridge and Pier Protective Devices and Systems," Book, Maxwell Scientific International, ISSN: 0 8247 6895 7 , 352 pages.
12. Young, R.A., (1980), " Marine Fender Specifications," ASCE Magazine, pp. 547-554.
13. Han, E., Priori, G., and Juran, D., (1978), " Improved Fender Systems for Shallow and Deep Draft Berths," Final Report MA-GEN-970-78046, 218 pages.
14. "Marine Fenders Becoming an Essential Insurance Against Damage" (1979). Book, Cargo Systems Publications, 97 pages.
15. Maher, M.H., Gucunski, N, and Chae, Y.S., (1996), " Composite Fender and Sheet Piles in Marine Front Systems," in the Proceedings of First International Conference on Composites in Infrastructure, National Science Foundation, pp 665-675.
16. Volk, R.J., (1996), " Composites in Civil Infrastructure and Marine Applications," Proceedings of the First International Conference on Composites in Infrastructure, National Science Foundation, pp. 1115-25.
17. "San Diego's Composite Pier Piling Test" (1997). Civil Engineering News, Vol 9, Issue 10 pp 26-32.

18. Sicking, D.L., Reid, J.D., and Rohde, J.R., (1999) "Development of a Flared Energy-Absorbing Terminal for W-Beam Guard-Rails," *Transportation Research Record Issue 1690*, pp 8-16.
19. Dolce, M., Filardi, B., Marnetto, R., and Nigro, D., (1997), "Experimental Tests and Applications of a New Biaxial Elasto-Plastic Device for the Passive Control of Structures." *Proceedings of the Fourth World Congress on Joint Sealants and Bearing Systems for Concrete Structures*, ACI, pp 651-674.
20. AASHTO Guide Specification and Commentary for Vessel Collision Design of Highway Bridges, Vol. I, Final Report, Washington DC, February 1991.
21. Maritime Casualty News (2002)
22. Robert F Jansen, ACMC Pacific Port Consultant, PTE Ltd Singapore. "Safe Berthing of Liquid Gas Carriers", *Port Technology*, Ed. 11, Sec. 6.
23. Richard Lampo, Thomas Nosker, Doug Barno, John Busel, Ali Maher, Piyush Dutta, and Robert Odello. "Development and Demonstration of FRP Composite Fender, Loadbearing, and Sheet Piling Systems", *Research Laboratories USACERL Technical Report 98/123, September 1998*
24. M.W. Whitney, I.E. Harik and D.L. Allen, "Barge Collision Design of Highway Bridges". *Journal of Bridge Engineering*, May 1996.
25. US Army Corp of Engineers *Construction Engineering Research Laboratories USACERL*, Technical Report 98/123.

## APPENDIX A

### Appendix A1: Bridge Pier Collision Forces Design – An Example

#### Design Data and Specifications

The following design example illustrates the application of the AASHTO Guide specification to determine the magnitude of the vessel or barge impact forces against which bridge piers are 100% protected. The calculations provided are in accordance with the AASHTO Guide Specification (1991); however, they are only intended to illustrate the application of design Method II with the data obtained from the Journal of Bridge Engineering /May /1998<sup>(24)</sup> and do not constitute a rigorous analysis of the bridge design. The results generated in this example are based on the statistical data obtained from the U.S. Coast Guard, the U.S. Army Corps of Engineers and the American Waterways Operators.

The data gathered in order to apply design Method II of the guide specification were: (1) barge size and capacities; (2) number of barges in a flotilla column and row; (3) river elevations; (4) flotilla transit velocity; and (5) probabilities of aberrancy. For illustrative purposes, this design example is concentrated on barge traffic on one of Kentucky's

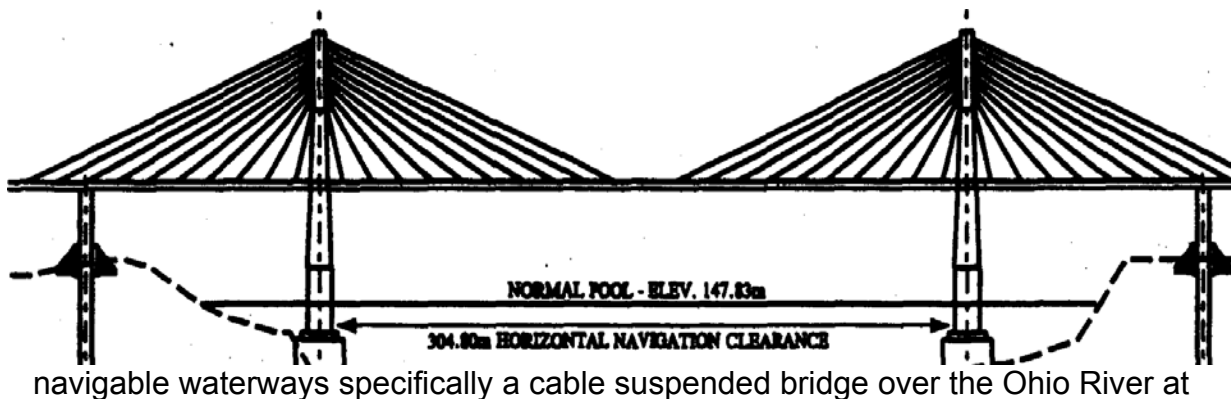

Source: Journal of Bridge Engineering/May 1998/53

Figure A30. Bridge Over the Ohio River at Maysville

#### Equivalent Static Impact Load Calculations

The procedure in the AASHTO Guide Specification<sup>(20)</sup> for calculating impact loads incorporates the flotilla kinetic energy when determining the lead barge damage depth. The flotilla equivalent static impact load is then calculated using the barge damage depth. The barge flotilla kinetic energies, damage depths, and equivalent static impact loads (Table A8) were determined from Equations (2) and (3) given on pages 68 and 69.



**Table A10: Equivalent Static Load Calculations-Maysville Bridge East Tower Pier**

Flotilla Category <sup>(a,b)</sup>	Capacity  (MN)	Number of barges per col. multiplier	Kinetic energy east tower pier  MN.m	Barge width correction factor	Barge damage depth east tower pier	Equivalent static impact force east tower pier  MN
1	2	3	4	5	6	7
1(AA)	5.418	0.00	0.00	0.73	0.00	0.00
2(AB)	8.478	0.00	0.00	0.95	0.00	0.00
3(AC)	69.909	0.00	0.00	1.54	0.00	0.00
4(AD)	4.457	0.00	0.00	1.57	0.00	0.00
5(BA)	12.633	0.00	0.00	0.71	0.00	0.00
6(BB)	10.907	4.00	58.14	0.96	6.24	15.34
7(BC)	30.372	5.92	239.60	1.54	9.41	32.49
8(BD)	32.597	0.00	0.00	1.69	0.00	0.00
9(CB)	16.619	0.00	0.00	0.77	0.00	0.00
10(CC)	32.499	5.11	221.30	1.54	8.98	31.42
11(CD)	3.745	0.00	0.00	1.71	0.00	0.00
12(DB)	16.814	5.00	112.03	0.76	11.99	19.23
13(DC)	24.154	5.38	173.17	1.07	11.17	25.57
14(DD)	23.513	6.00	188.00	1.54	8.15	29.37
15(EA)	10.284	0.00	0.00	1.71	0.00	0.00
16(EB)	12.233	5.00	81.51	0.74	10.07	16.42
17(EC)	27.099	5.38	194.28	1.24	10.38	27.93
18(ED)	68.627	0.00	0.00	2.06	0.00	0.00
19(FC)	47.285	4.50	283.55	1.54	10.39	34.89
20(FD)	37.899	0.00	0.00	1.79	0.00	0.00
21(GC)	57.622	4.00	307.14	1.54	10.88	36.11
22(GD)	66.697	0.00	0.00	1.62	0.00	0.00
23(HC)	74.579	3.23	321.00	1.54	11.16	36.80
24(HD)	56.492	2.00	150.56	1.59	6.90	27.15
Single	57.622	1.00	14.39	1.54	1.40	12.69

<sup>(a,b)</sup> The first letter in the parentheses is the length of the barge designation; the second is the width of the barge designation.

**Flotilla Frequency Distribution**

Table A11 lists the specific information used to calculate the associated frequencies for each of the flotilla categories. The average number of barges comprising the rows and columns was used to determine the average number of barges in a flotilla category. The total annual number of barges for a category is then divided by the average number of barges in a flotilla category to determine the associated annual flotilla frequency.

**Table A11. Flotilla Frequency Distribution for Maysville Bridge**

Flotilla Category 1	Total Barges 2	Barge per Flotilla			Passages per year 6
		Column 3	Row 4	Total 5	
6(BB)	43	3.3330	1.6667	5.5560	8
7(BC)	1170	3.4219	1.7188	5.8816	199
10(CC)	571	3.3490	1.9688	6.5935	87
12(DB)	233	5.0000	1.0000	5.0000	47
13(DC)	51269	4.5837	2.8274	12.9600	3956
14(DD)	11	6.0000	2.0000	12.0000	1
16(EB)	4	5.0000	1.0000	5.0000	1
17(EC)	4822	4.5837	2.8274	12.9600	372
19(FC)	70	3.3537	2.3159	7.7600	9
21(GC)	2658	3.3884	1.9876	6.7348	395
23(HC)	30	2.0000	1.7176	3.4352	9
24(HD)	61	1.6667	1.0000	1.6667	37

**Equivalent Static Barge Impact Load Frequencies**

Table A11 summarizes the frequencies and the associated equivalent static impact loads for the 12 flotilla categories operating on the Maysville section of the Ohio River for both the east and west piers.

**Design Barge Selection**

The design minimum barge selected for the example bridge section of the Ohio River was an 88.39mx16.15m barge since it is one of the largest barges currently in use on the river. The typical dimensions for the 88.39m x 16.15m barge along with other barge sizes are given in Table A12.

**Table A12. Equivalent Static Barge Impact Load Frequencies (ESBILF) for West and East Pier Fenders for Maysville Bridge**

<b>Flotilla Category</b>	<b>No. Barges in Flotilla</b>	<b>Flotilla Frequency Per Year</b>	<b>Equivalent Impact Force West Pier Fender</b>	<b>Equivalent Impact Force East Pier Fender</b>	<b>Starting Elevation of Uniform Barge Impact Load</b>	<b>Length of Uniform Barge Impact Load</b>
<b>6(BB)</b>	3.33	4	15.035	15.346	152.25	0.91
<b>7(BC)</b>	3.42	105	31.894	32.561	152.25	0.91
<b>10(CC)</b>	3.35	46	30.871	31.493	152.25	0.91
<b>12(DB)</b>	5	25	18.816	19.261	152.25	0.91
<b>13(DC)</b>	4.58	2076	25.088	25.622	152.25	0.91
<b>14(DD)</b>	6	1	28.824	29.447	152.25	0.91
<b>16(EB)</b>	5	1	16.058	16.458	152.25	0.91
<b>17(EC)</b>	4.58	195	27.401	27.979	152.25	0.91
<b>19(FC)</b>	3.35	5	34.251	34.963	152.25	0.91
<b>21(GC)</b>	3.39	205	35.452	36.209	152.55	1.22
<b>23(HC)</b>	2	5	36.12	36.876	152.55	1.22
<b>24(HD)</b>	1.67	19	27.134	27.223	152.55	1.22

**Table A13. Typical Barge Size Dimensions and Capacities**

<b>Length</b>	<b>Width</b>	<b>Depth</b>	<b>Empty draft</b>	<b>Loaded Draft</b>	<b>Bow Depth</b>	<b>Bow rake length</b>	<b>Head log height</b>	<b>Cargo Weight</b>	<b>Empty weight</b>
<b>La m</b>	<b>Bm m</b>	<b>Dv m</b>	<b>DE m</b>	<b>DL m</b>	<b>Da m</b>	<b>RL m</b>	<b>HL m</b>	<b>Cc MN</b>	<b>WE MN</b>
59.44	10.67	3.66	0.52	2.65	3.96	6.1	0.61-0.91	15.12	1.78
88.39	16.15	3.66	0.52	2.65	3.96	7.62	0.61-0.92	32.92	5.34
76.20	21.95	5.18	0.76	3.81	5.49	9.14	0.91-1.52	44.48	11.57

The uniform impact load, starting elevations, uniform load length, and equivalent static impact force for the east and west pier fenders due to the impact of a single fully loaded barge are 152.55m, 1.22m, 12.68MN and 12.41MN, respectively.

**River Velocity**

River velocity was added to the flotilla transit velocity to get the flotilla total velocity, V, used in equation (2) to calculate the flotilla kinetic energy.

**Flotilla Velocity**

The flotilla transit velocity, which is added to the river velocity to determine the flotilla total velocity, V, used in equation (2), is based on data provided by the U.S. Coast Guard. The data suggested that typical flotilla transit velocities were between 2.13 m/s (four knots, 7 fps, 5 mph) and 3.05 m/s (six knots, 10 fps, 7 mph). The higher value of 3.05 m/s was used in the calculations.

**Probability of Aberrancy**

The likelihood that a flotilla will be out of control, or aberrant, was used to calculate the probability that a flotilla will collide with the Maysville bridge pier fenders. The probability of aberrancy at the bridge was found to be  $1.77 \times 10^{-4}$  (24). The average probability of aberrancy for the Ohio River was found to be a more conservative value of  $5.29 \times 10^{-4}$ . However, the site specific value of  $1.77 \times 10^{-4}$  for the river section was used in the design.

**Design Barge Acceptance Criteria Calculations**

For this design example, an initial fender impact capacity of 22.24 MN (5,000 kips) was assumed. From this, the probability of collapse (PC) was calculated for each pier fender using the equivalent static impact force presented in Table 8A and the following two equations:

$$PC = \left(1 - \frac{H_p}{P_s}\right) / 9 \text{ for } 0.1 \leq \frac{H_p}{P_s} < 1.0 \dots\dots\dots(A-12)$$

and

$$PC = 0 \text{ for } \frac{H_p}{P_s} > 1.0 \dots\dots\dots(A-13)$$

in which  $H_p$  = lateral capacity of the bridge pier; and  $P_s$  = equivalent static impact load.

**Geometric Probability (PG)**

Figure A31 illustrates the appropriate geometry for the calculation of the geometric probability (PG). It was conservatively assumed that the geometric probabilities are the same for the west and east piers fenders. In addition, it was assumed that the entire flotilla could fit between the pier fenders and the river banks.

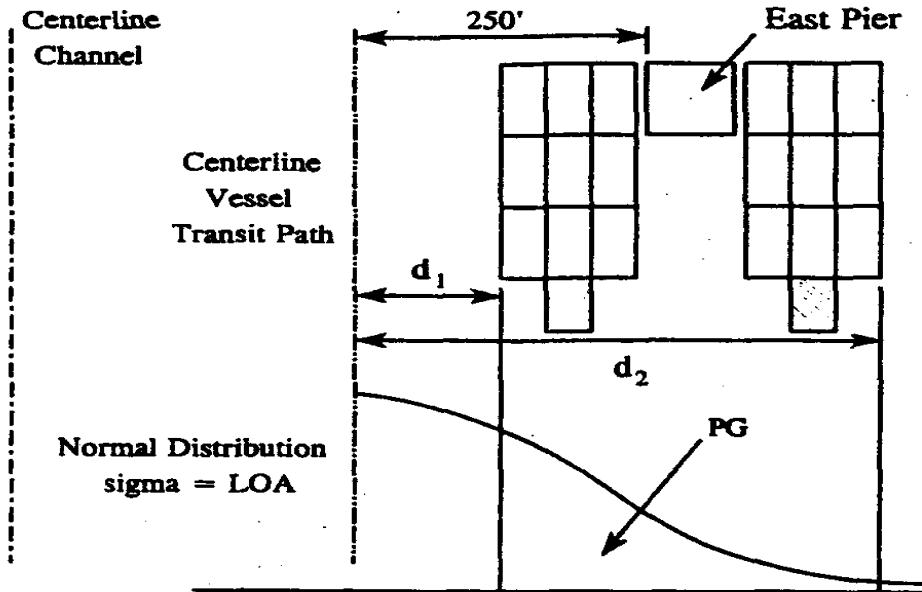

**Figure A31. Dimensions for Geometric Probability Calculations, Maysville Section of Ohio River**

The values for geometric probability were calculated from the following equation given in the *AASHTO Guide Specification* <sup>(20)</sup>

$$PG(X_1, X_2) = \int_{X_1}^{X_2} \left( \frac{1}{2\pi} \right) \sqrt{e^{-t^2}} dt \quad \dots\dots\dots(A-13)$$

in which the limits  $x_1$  and  $x_2$  are defined as:

$$X_1 = d_1/LOA; \quad X_2 = d_2/LOA \quad \dots\dots\dots(A-14)$$

where  $d_1$  and  $d_2$  = dimensions defined in Figure A31, and LOA = overall length of the flotilla. The results of the calculations are presented in column 4 of Tables A13 and A14 for each of the 12 flotilla categories considered for the Maysville Bridge. Combining this information with the probability of aberrancy, the annual frequency of collapse can be determined from the equation:

$$AF = N (PA)(PG)(PC) \quad \dots\dots\dots (A-15)$$

Note that, in order to apply Method II, a preliminary bridge pier fender design must have been completed, since a lateral capacity for the fenders is required to calculate the probability of collapse. If the annual frequency of collapse for the entire bridge is found to be unacceptable, then a redesign of the bridge pier fender is required, and the new lateral capacity is used to calculate the probability of collapse. With successive

**Table A14. Annual Frequency (AF) of Collapse for East Pier with Hp=31.89MN**

Flotilla Category	Flotilla frequency per year	Probability of aberrancy	Geometric probability	Probability of collapse	Annual frequency	Summation of annual frequencies
1	2	PA 3	GP 4	PC 5	AF 6	7
<b>6(BB)</b>	4	1.7704 X 10 <sup>-4</sup>	0.1025	0.0000	0.000	0.000
<b>7(BC)</b>	105	1.7704 X 10 <sup>-4</sup>	0.0942	0.0000	0.000	3.987 X 10 <sup>-6</sup>
<b>10(CC)</b>	46	1.7704 X 10 <sup>-4</sup>	0.1188	0.0000	0.000	3.987 X 10 <sup>-6</sup>
<b>12(DB)</b>	25	1.7704 X 10 <sup>-4</sup>	0.0350	0.0000	0.000	3.987 X 10 <sup>-6</sup>
<b>13(DC)</b>	2076	1.7704 X 10 <sup>-4</sup>	0.0957	0.0000	0.000	3.987 X 10 <sup>-6</sup>
<b>14(DD)</b>	1	1.7704 X 10 <sup>-4</sup>	0.0832	0.0000	0.000	3.987 X 10 <sup>-6</sup>
<b>16(EB)</b>	1	1.7704 X 10 <sup>-4</sup>	0.0336	0.0000	0.000	3.987 X 10 <sup>-6</sup>
<b>17(EC)</b>	195	1.7704 X 10 <sup>-4</sup>	0.0964	0.0000	0.000	3.987 X 10 <sup>-6</sup>
<b>19(FC)</b>	5	1.7704 X 10 <sup>-4</sup>	0.1114	0.0076	7.542 X 10 <sup>-7</sup>	4.949 X 10 <sup>-6</sup>
<b>21(GC)</b>	205	1.7704 X 10 <sup>-4</sup>	0.1080	0.0112	4.372 X 10 <sup>-5</sup>	5.685 X 10 <sup>-5</sup>
<b>23(HC)</b>	5	1.7704 X 10 <sup>-4</sup>	0.0997	0.0130	1.147 X 10 <sup>-6</sup>	5.817 X 10 <sup>-5</sup>
<b>24(HD)</b>	19	1.7704 X 10 <sup>-4</sup>	0.0764	0.0000	0.000	5.817 X 10 <sup>-6</sup>

iterations, a lateral fender capacity can be obtained which satisfies an acceptable annual frequency of collapse. Since the requirements for NJDOT is for the fender system to absorb 100% of the impact energy, the frequency of collapse of the bridge pier should be set at zero.

Calculations for *AF*, were completed for both the east and west pier towers. After an unacceptable annual frequency of collapse was noted, the process was repeated using a tower impact capacity of 31.89 MN (7,170 kips). The results for the revised probability of collapse calculations are found in column 5 of Tables A14 and A15. Tables A14 and A15 also give the results for the revised calculations for the annual frequency of collapse (column 7) for the east and west tower piers, respectively. It should be noted that, although the *AF* for the east fender slightly exceeds the acceptable value of 0.00005, the summation of annual frequencies of collapse for all flotilla categories, with respect to both pier fenders, is 0.0001.

The results indicate that the "design flotilla," or flotilla category, for which the probability of collapse equals zero (i.e., the lateral capacity of bridge fenders at the impact location equals the flotilla equivalent static impact load) is category CC. The lateral capacity required for the bridge pier fenders should not be less than [31.89 MN (7,170 kips)].

**Table A15. Annual Frequency of Collapse for West Pier with  $H_p=31.89MN$**

Flotilla Category	Flotilla frequency per year	Probability of aberrancy	Geometric probability	Probability of collapse	Annual frequency	Summation of annual frequencies
1	2	PA 3	GP 4	PC 5	AF 6	7
<b>6(BB)</b>	4	$1.7704 \times 10^{-4}$	0.10250	0.00000	0.0000	0.0000
<b>7(BC)</b>	105	$1.7704 \times 10^{-4}$	0.09420	0.00000	0.0000	0.0000
<b>10(CC)</b>	46	$1.7704 \times 10^{-4}$	0.11880	0.00000	0.0000	0.0000
<b>12(DB)</b>	25	$1.7704 \times 10^{-4}$	0.03500	0.00000	0.0000	0.0000
<b>13(DC)</b>	2076	$1.7704 \times 10^{-4}$	0.09570	0.00000	0.0000	0.0000
<b>14(DD)</b>	1	$1.7704 \times 10^{-4}$	0.08320	0.00000	0.0000	0.0000
<b>16(EB)</b>	1	$1.7704 \times 10^{-4}$	0.03360	0.00000	0.0000	0.0000
<b>17(EC)</b>	195	$1.7704 \times 10^{-4}$	0.09640	0.00000	0.0000	0.0000
<b>19(FC)</b>	5	$1.7704 \times 10^{-4}$	0.11140	0.00760	$7.542 \times 10^{-7}$	$7.542 \times 10^{-7}$
<b>21(GC)</b>	205	$1.7704 \times 10^{-4}$	0.10800	0.01120	$4.372 \times 10^{-5}$	$4.447 \times 10^{-5}$
<b>23(HC)</b>	5	$1.7704 \times 10^{-4}$	0.09970	0.01300	$1.147 \times 10^{-6}$	$4.562 \times 10^{-5}$
<b>24(HD)</b>	19	$1.7704 \times 10^{-4}$	0.07640	0.00000	0.0000	$4.562 \times 10^{-5}$

## Appendix A2: Example of Preliminary Fender Selection

This example is based on the impact load of 31.89 MN, designed in the previous example for the Ohio River at Maysville, Kentucky.

### Assumptions:

1. Lateral design load=31.89MN(7170kips) – see design example, Appendix A1
2. Effective length of the piles= 10ft (Figure A24)
3. Selection based on standard composite piling (Table A6)
4. 100% of the impact force to be absorbed by one of the pier end dolphins or the piles and fender panels surrounding one pier (Figure A29)

Given effective bending moment,  $M_{\text{eff}} = PL/4$  (Eqn. A-2, page 72)

where:

P = Load (lbs);  
M= Moment (in-lbs); and  
L = Effective length.

It follows that,

$$M_{\text{eff}} = (7170 \times 10^3) \text{ lbs} \times (10 \times 12) \text{ in} = (1.2 \times 10^7) \text{ in-lb} \times 70$$

From Table A7, page 64, a moment of  $(1.2 \times 10^7)$  in-lbs interprets to a stiffness  $EI = 1.34 \times 10^{10}$ , which corresponds to the product identification number “24-4”.

From Table A6, page 62, a product identification number “24-4” corresponds to a standard pile of a nominal diameter of **24in.**, **FRP shell thickness of 0.364in.**, and **acrylic skin thickness of 0.02 in.**

From equation (a) and assumptions above, this will imply that to fender a pier-end against a lateral impact force of 31.89 MN, **seventy (70) 24inch diameter** hardcore composite piles will be required by either each dolphin or the piles surrounding each pier. Installation can be accomplished by integrating reinforced concrete deck cast in a concrete stay-in-place (SIP) formwork. The composite SIP can serve as a template for vibrating the piles and to mold the cast-in-situ concrete. **(Note that if bigger diameters for the composite pilings are used, the number of piles required should decrease accordingly.)**

Assuming the use of the largest available diameter hardcore composite tubular piling of 72 inch for the dolphins, then, about **twenty (20) 72inch** diameter composite piles should be required for the lateral impact force of 31.89MN. The resulting dolphin will be



similar to the one provided for the ferry system at Delaware Coast (Figure A32 below) which is made of **forty-four (44) 18-inch diameter composite piles**, with a capacity to absorb the forces generated by 2100-ton ferry vessels moving at 3 knots (equivalent to 11.66MN compared to 31.89MN assumed for this example).

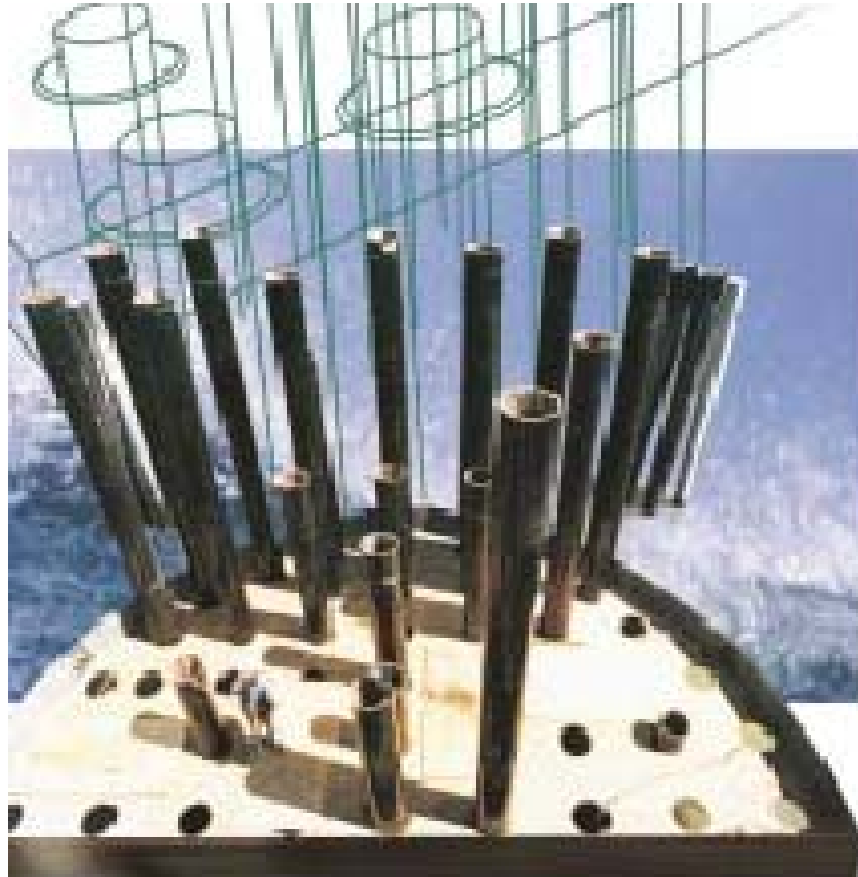

**Figure A32. A Dolphin of Composite Piles with Stay-in-Place Formwork**

Each bridge pier can further be shielded all round by about **thirty-five (35) 48 inch diameter composite piles** held together in a stay-in-place formwork to form a monolithic structure surrounded by composite fender panels -- *acting as rubber bumpers* -- faced with UHMW polyethylene rubbing strips for decreased vessel impact force due to the very low coefficient of friction (refer Figure 29). Assuming the worse case collision, this system will be capable of absorbing 100% of the design lateral force of 31.89 MN.

The use of **monopile composite** as an alternative selection for the dolphins was first to be considered, but subsequently discarded because of their limited energy absorption capabilities in relation to the assumed design force. From the literature it was observed

that Hardcore Composites, claimed to be the sole manufacturer of monopile composites, manufactured the largest monopile composite -- in August 2000 -- which was installed at Cape May New Jersey (Figure 33 below). This was a 80ft long, 60inch diameter monopile, with a maximum energy absorption capacity of only 240kips. This is about 3% of the energy absorption requirements when compared to the design force of 7170 kips).



**Figure A33. Installation of a Composite Monopile at Cape May, New Jersey**

The fender system at Casco Bay Bridge is similar to the one proposed here, but it makes use of different fender types and materials. The pier-end of this system is protected by **four 60-foot (720inch) diameter steel cellular sheet pile dolphins** filled with gravel. This system was designed to absorb the energy of a 50,000-dwt vessel traveling at 5 knots and striking the fenders at a 15° angle (an equivalent of 46.25 MN lateral load compare to the design load of 31.89MN). Although this system demonstrates higher energy absorption capabilities, it is deemed inferior to the composite piling system from the life-cycle-cost point of view. This may be due to the steel rigidity, which can destroy marine vessels during impact and result in high costs for environmental clean-up in case of spillage.

# **PART B: PRECAST OR PREFABRICATED BRIDGE DECK SYSTEMS**

## **INTRODUCTION**

### **Pre-Cast Bridge Superstructures**

There are two general configurations found in the superstructures of modern pre-cast/pre-stressed concrete bridges. The first configuration takes the form of precast concrete girders supporting a pre-cast or cast-in-place concrete deck. The second configuration takes the form of concrete boxes, T-beams or channel beams to be placed next to each other. The top flanges of these boxes or beams serve as bridge decks, requiring a much smaller amount of cast-in-place concrete, if any. The wearing surface for this type of bridge usually consists of a thin asphalt or latex concrete overlay. <sup>(1)</sup>

Many different types of precast concrete bridge superstructures have been built using variations of these configurations based on the specific design, function, constructability, and economic requirements of each bridge. The following is a partial list of different types of precast/prestressed concrete bridges including a description and any unique advantages or disadvantages associated with them.

#### **Solid Slab Bridges**

These bridges are precast concrete slabs of standard width and depth placed contiguously to form the bridge deck. This type of deck is cost efficient for spans of up to 30 feet. Maximum depth limits preclude their use in longer span bridges.

#### **Voided Slab Bridges**

This type of bridge superstructure is a variation of the solid slab deck that consists of precast concrete slabs with longitudinal voids to reduce their weight. This reduction in weight allows longer spans of up to 55 feet to be built economically.

#### **T-Beam Bridges**

There are several types of precast/prestressed T-Beams that are commonly manufactured including single, double, and multiple-T sections. These beams have variable top flange widths and are placed contiguously to form a ready-made bridge deck. The thin top flanges combined with the large depth of these beams allow them to be used in bridges spanning 30 feet (Triple-T) to 120 feet (Single-T).

#### **Bulb T-Beam Bridges**

These bridges have modified T-Beams that have a 4 foot top flange, a 2-foot bottom flange, and variable depths. One advantage of using these beams is that they are able to support longer spans than conventional T-Beams. However, the limited width of the top flange requires an expensive cast-in-place deck to complete the superstructure.

### **Decked Bulb T-Beam Bridges**

Another variation on the T-Beam, decked bulb T-Beams is manufactured with standard top flange widths of 5-10 feet, bottom flange width of 2 feet and variable depths. These beams can be placed contiguously to provide a ready-made deck and can span lengths up to 190 feet. The top flanges of these beams are cast with normal strength concrete (120 pcf, 6000 psi) while the rest of the section is made from high strength concrete (160 pcf, 8500 psi).

### **Channel Girder Bridges**

This beam's section is comparable to that of a double T-Beam without the overhanging flange. However, the flange and web of this type of beam are thinner, which makes it impractical when compared with the Double T-Beam.

### **Spread Box Beam Bridges**

Box beams have a hollow rectangular section and are manufactured with flange widths of 3 feet and 4 feet with variable depths. These beams are economical for use in the construction of bridges with spans of 60 to 100 feet. Two types of construction are associated with this type of section, spread box beam and adjacent box beam construction. In spread box beam construction, the beams are not placed contiguously and are designed to support a cast-in-place concrete deck. Adjacent box beams are placed contiguously which results in a ready-made deck.

### **I-Beam Bridges**

There are many different standard I-Beam sections in use including six types of AASHTO I-Beams and several other types that individual states have developed and adopted as their standard. The most notable difference between these sections is the web thickness, which ranges from 5 inch to 14 inch. Precast/prestressed concrete deck panels are often used to support a cast-in-place concrete deck in this type of construction. One advantage of this type of bridge is that the bridge deck is easily replaced once its service life has been reached. I-Beams can be used economically to support a wide range of spans (30 feet – 140 feet) and are the most commonly constructed types of prestressed concrete bridges in the United States.

### **Precast/Prestressed Concrete Deck Panels**

These are thin precast/prestressed panels that are commonly used in association with I-Beam bridges to support a cast-in-place bridge deck. The panels are left in place after the deck is poured and can act compositely with the cast-in-place deck. Deck panels offer an economical alternative to the costly installation and removal of wooden false-work.

### **U-Beam Bridges**

This type of beam resembles an inverted channel section and is said to have an "open cross section" as it does not have a top flange. A cast-in-place deck is constructed on top of the sections resulting in a superstructure that is similar to a spread box beam

superstructure. An advantage of U-Beams is their ability to support a horizontally curved bridge alignment.

### **Inverted T-Beam Bridges**

Inverted T-Beams (IT's) are essentially I-Beams without a top flange. They can be used efficiently in short to medium span bridges with a maximum span of 85 feet. This is a new technology that was developed to reduce the profile (overall depth) of short span bridges. Bridges have been built successfully in Nebraska, Iowa and Florida using this technology. However, performance analyses for IT's are not yet definitive due to their recent implementation.<sup>(2,3)</sup>

### **Post-Tensioned Precast Segmental Box Girders**

This type of construction is commonly used in medium to long span bridges. Single or multi-cell box girders are placed contiguously in the longitudinal direction and steel tendons are post-tensioned through ducts in the box girders to hold the segments together. One advantage is that this type of construction is very effective in building bridges with horizontally curved alignments. Another is that construction can proceed from above the bridge with all equipment stationed on previously constructed segments. This allows bridges to be built with relative ease over rough terrain and water.<sup>(1,4,5)</sup>

### **Through-Girder Bridges**

This type of bridge consists of post-tensioned box girders placed longitudinally, supporting precast concrete panels placed contiguously, to form the deck. The concrete panels are post-tensioned both transversely and longitudinally. The advantage of this type of bridge is its low profile, which offers more clearance in tight vertical grade separations than standard I-Beam or T-Beam construction.<sup>(6)</sup>

### **Pre-Cast Bridge Decks**

Two broad design categories of precast bridge decks were studied to determine their prevalence, performance, cost efficiency, and methods of design and construction. The first category was total precast superstructures. These are superstructures that consist of precast beams or girders cast with an integral deck. Some examples are tee beams, double-tee beams, bulb-tee beams, adjacent box beams, and precast segmental components. If specified, these beams can be overlaid with a concrete wearing surface, with little or no bridge deck forming required. The second category was precast bridge deck panels. These are partial or full depth precast concrete panels that are supported by beams or girders to make up the superstructure of the bridge. Full depth precast concrete bridge deck panels are shown in Figure B1. The American Association of State Highway and Transportation Officials (AASHTO) has set up a Technology Implementation Group which is dedicated to researching and promoting the use of precast concrete bridge components.<sup>(11,20)</sup> The work they have done, including video presentations, can be accessed through their web site, [www.aashtotig.org/focus\\_technologies/prefab\\_elements/elements.stm](http://www.aashtotig.org/focus_technologies/prefab_elements/elements.stm).



**Figure B1. Full Depth Concrete Bridge Deck Panels**

The National Bridge Inventory, established over thirty years ago by the Federal Highway Administration, is a database containing classifications, condition reports, and other information about most of our nation's public bridges.<sup>(38)</sup> A presentation of this information can be found at the following web address:

[www.nationalbridgeinventory.com](http://www.nationalbridgeinventory.com). In order to study different types of bridges and the materials they are composed of, it is important to understand the means by which they are categorized. The NBI classifies bridges based on the material composition and/or method of construction of the superstructure of the main span. Approximately 50 percent of bridges built in the United States are classified as prestressed concrete bridges.<sup>(12)</sup>

An analysis of prestressed and precast bridge structures done by Dunker and Rabbat contains construction and performance statistics of prestressed bridge structures for the first forty years of their existence.<sup>(13)</sup> Their report is a compilation of data from the National Bridge Inventory. However, the data collected by the National Bridge Inventory does not differentiate between precast prestressed bridges and those that are cast-in-place. But other research has shown that over one third of all prestressed bridge superstructures are built from precast box beams.<sup>(13)</sup> In addition, other types of superstructures with precast bridge decks make up a large portion of the remaining prestressed bridge types. The eight most common types of prestressed concrete bridge superstructures built between the years of 1952 and 1989 are as follows:

- Stringer.
- Multiple box beam.
- Slab.
- Tee beam.
- Continuous stringer.

- Single (spread) box beam.
- Continuous multiple box beam.
- Continuous single box beam.
- Total precast superstructure bridges.

In the group of eleven states from Illinois to New York and New Jersey, the most common prestressed concrete bridge is the multiple precast box type.<sup>(13)</sup> Therefore, this research has been developed under the assumption that qualitative findings about the design, construction and performance of prestressed bridge superstructures are an accurate reflection on precast bridge structures as well, and are referenced in this regard.

## PERFORMANCE HISTORY

### Total Superstructure

An analysis done by Dr. Dunker and Dr. Rabbat of the information compiled by the National Bridge Inventory as of August 16, 1990 has provided valuable insight into the performance history of precast/prestressed (PC/PS) concrete bridges. According to this analysis, the first prestressed (and precast) bridges were built in the early 1950's. Despite having planned service lives of 50 years, the majority of these bridges were in good condition and were expected to last well beyond their planned service lives at the time of inspection in 1990.<sup>(13)</sup> In fact, a smaller percentage of bridges built PC/PS concrete were found to be structurally deficient than those that were built with other materials, such as timber and steel in corresponding age and span categories. There was found to be little difference in the percentage of structurally deficient bridges between bridges built with prestressed/precast concrete and those built with reinforced concrete.

Further work by Dr. Dunker and Dr. Rabbat details the variation of performance of different bridge types within the category of prestressed and precast concrete bridges. The two most common PS/PC concrete bridges, the stringer and multiple box types, as well as the slab and all continuous PC/PS bridges exhibited very low structural deficiency rates. However, some parts of the country have experienced problems with cracking in the wearing surface and the grouted joints between adjacent box beams.<sup>(14)</sup> This problem is being addressed by the Transportation Research Board in an effort to develop more effective grout key and transverse tying systems for adjacent box beams. Statistics show that there is a higher percentage of structurally deficient bridges in the tee-beam and single/spread box beam categories, although the percentages are still low when compared with bridges built of other material types.<sup>(13)</sup>

Lateral continuity in adjacent box beam bridges is very important. A problem that has been noticed is cracking over the longitudinal joint where adjacent boxes meet. This is due to a loss of bond between the beams resulting in independent action. Therefore, it

is important that connection details provide for lateral continuity between the beams. Several methods can be used to provide this continuity including lateral prestressing, tie-rods, shear-keys, or a reinforced concrete slab of appropriate minimum thickness.

The strong history of performance of PC/PS concrete bridges has helped to grow their popularity and broaden their range of use. Prestressed concrete bridges are now prevalent in a wide range of span lengths up to 140 feet and greater, where the span lengths of their predecessors were limited to about 100 feet.<sup>(13)</sup> However, there have been some problems with some experimental prestressed concrete bridges with span lengths greater than 200 feet. The increased versatility and greater available span lengths have helped PC/PS bridges gain a foothold in the highway bridge industry. In recent years the total number of bridges built annually has been declining but the number of PC/PS bridges built annually has remained steady, indicating a growing market share for these types of bridges.<sup>(13)</sup>

### **Segmental Bridges**

Segmental construction also employs the use of total precast concrete superstructure elements. One advantage of segmental bridges is that they can be built with minimal environmental impact to their surroundings.<sup>(37)</sup> Segmental bridge construction is often used in environmentally sensitive areas or in areas of rough terrain where conventional bridge construction would be very difficult (Figure B2). This construction method employs longitudinally post-tensioned tendons to tie precast bridge segments together.



**Figure B2. Construction of a Segmental Bridge**



The tendons run through internal ducts (visible in Figure B3),<sup>(39)</sup> that are filled with grout after the post-tensioning is complete, to bond the tendons with the superstructure and protect them from the elements. Protecting the internal tendons from corrosion is a critical aspect in the design and construction of these types of bridges.<sup>(22)</sup>



**Figure B3. Segmental Components (Post-Tensioning Ducts Visible)**

Segmental bridges have been successfully built in several states in the U.S. and have performed well for many years. However, this type of construction is controversial in the United Kingdom. Failures of segmentally constructed bridges in the U.K. have been documented and linked to problems with corrosion of the internal tendons, most likely due to insufficient or non-existent grout in the ducts. Specifically, these were the Bickton Meadows footbridge in 1967 and the Ynys-y-Gwas Bridge in 1985.<sup>(22)</sup> These high profile disasters led to a ban on the construction of new post-tensioned bridges, both precast and cast-in-place, in 1992. The ban was lifted in 1996 for cast-in-place post-tensioned structures, but is still in effect for precast. Despite the moratorium and the serious concerns regarding corrosion protection in this type of bridge construction, research done by the NCHRP indicates that the majority of segmental bridges in the U.K. and Europe are in good condition. The few problems that have occurred were products of poor construction or design, not with the fundamental principles of segmental construction. There has been no evidence of tendon corrosion in segmental bridges built in North America. However, extensive testing for this type of corrosion has not yet been incorporated into standard bridge inspections and evaluations.

## Partial and Full Depth Pre-Cast Bridge Deck Panels

Partial depth precast concrete panels are often used as stay-in-place (SIP) bridge deck forms in order to eliminate the time and labor intensive practice of installing and removing wooden formwork, and consequently to reduce construction time.<sup>(11,15)</sup> The 3-inch to 4-inch panels are placed directly on top of the supporting beams, with gaps left between the precast slabs. The panels are generally fabricated in four-foot to eight-foot sections, depending on the method of transport to the job site.<sup>(30)</sup> The remaining thickness of the deck is then cast in place and the concrete is allowed to fill in the gaps between panels, forming a composite deck. Usually some sort of shear reinforcement is used such as shear loops, bars or keys formed in the concrete.<sup>(41)</sup> SIP deck forms have been accepted and used across the country with varying degrees of success. According to NCHRP research, many states have had success with this type of construction. There are bridge decks built with partial depth precast panels that have been in service for twenty years and have not experienced any problems. However, one state has not enjoyed the same success with SIP forms. In Illinois, there are several documented cases of problems with lateral and longitudinal reflective cracking in the cast-in-place portion of the deck above the precast panels.<sup>(15)</sup>

The Illinois Department of Transportation banned the use of precast/prestressed deck planks in 1985, after experiencing problems with longitudinal reflective cracking in bridge decks where these planks had been used. Research was done to find the cause of the problem and its solution. In 1998 the redesigned deck planks were used in two IDOT bridge projects. These deck planks had a minimum thickness of three inches and were required to have a minimum age of sixty days at the time of the cast-in-place deck pour. The results were better in these two projects, but still there were problems. Again it was found that these decks had a higher occurrence of transverse cracking than what had been found in cast-in-place bridge decks.<sup>(15)</sup> A separate study done by the Transportation Research Board in 1978 claims that these panels have been used successfully in several states and have performed well for over twenty years. However, the report also made mention of isolated cases of reflective cracking over the longitudinal joints.<sup>(40)</sup>

Further research has since been done and a new type of partial depth bridge deck panel, called Nudeck, has been developed that is designed to eliminate the problems experienced by the Illinois Department of Transportation. It was determined that reflective cracking is a result of a lack of continuity through the joints between adjacent precast panels and a lack of stress development in the prestressing strands due to insufficient panel widths spanning the supporting girders. In the Nudeck system, continuity is established in the transverse direction by casting the panels the full width of the deck. Longitudinal continuity is achieved through the use of shear keys and reinforced pockets to connect adjacent panels. Testing that has been done with Nudeck panels indicates that the number, size and length of cracks found in the cast-in-

place topping is far less than that found with conventional SIP systems tested under the same loading conditions. Also, it was found that subsequent creep in the prestressed panels creates compression in the cast-in-place deck so that the cracks that do occur close up tightly after the loading is removed.<sup>(30)</sup>

An alternative to the use of partial depth SIP's with a cast-in-place wearing surface is to use full depth precast or precast prestressed concrete panels topped with a much thinner wearing surface. Full depth panels can be placed on steel rolled beams, plate girders, or concrete girders.<sup>(31)</sup> Their versatility allows them to be used efficiently in many different situations. This type of bridge deck system is especially suited for bridge rehabilitation where fast construction times and minimal interference to traffic is very important. Construction can be sequenced such that all of the precast panels can be fabricated and made ready for installation before the existing bridge deck is demolished. The durability of bridge decks constructed with full depth precast concrete panels seems to be quite good. In a national field performance survey, Issa et al, found that bridge decks built with the panels have performed well.<sup>(26)</sup> At one time in their history, there were problems with the methods used to attach the panels to the supporting girders. A report published in 1978 by the National Cooperative Highway Research Program (NCHRP) asserted that over time, full depth precast panels had a tendency to break up around the hold-down arrangements and float freely on the girders. However, with the improved methods of design and construction in use today, that is no longer a problem.

Another positive attribute of full depth, precast bridge panels is their resistance to corrosion. Researchers at the Harcourt Butler Technological Institute in Kanpur, India have had encouraging results when working with precast deck panels in an experimental setting. Kumar and Rao found that in a chemically aggressive environment, precast bridge decks are much more resistant to deterioration caused by sulfate attack than are cast-in-place decks.<sup>(16)</sup> The reason for this is that the exposure histories for the two types of decks are quite different although their environmental situation is identical. Cast-in-place bridge decks are exposed to the harsh conditions from the very beginning, when the concrete is in its "fresh" state. However, precast decks are usually allowed to cure and harden, reaching a "mature" state before being exposed to the aggressive environment. Kumar and Rao explain that as concrete hardens the porosity is reduced, thereby reducing chemical intrusion into the deck. The lower porosity of precast decks at the time of erection better protects them from aggressive chemicals and deterioration.<sup>(16)</sup>

A field inspection of full depth precast concrete panel bridge decks was performed by a team from the University of Illinois at Chicago (UIC), led by Issa. The inspections began in September of 1993 and concluded in May of 1995, with the inspecting of several bridges in the states of Illinois, Connecticut, Virginia, Maryland, Iowa, California, New York, Alaska, Ohio, Pennsylvania, and Washington D.C.<sup>(26)</sup> The team's findings were presented in a paper that was written for the Illinois Department of Transportation titled "Field Performance of Full Depth Precast Concrete Panels in Bridge Deck Reconstruction".<sup>(26)</sup> The paper provides construction details and deck performance and

condition for each bridge. The following is a summary of the inspection results of bridges in the states of Illinois, Connecticut, Maryland, and New York.



**Figure B4. Bayview Bridge, Quincy, Illinois**

The first bridge inspected by the team from UIC was the Bayview Bridge in Quincy, Illinois (see Figure B4).<sup>(42)</sup> This bridge was built in 1986 and suffered damage resulting from the flooding of the Mississippi River in 1993. However, most of the damage was suffered in the approach spans, not the river spans which were the focus of the inspection. The main river structure of this bridge consists of three continuous cable-stayed spans with a 9-inch thick precast deck and a 1  $\frac{3}{4}$  inch bituminous wearing surface. The full width deck panels are 46.5ft wide and have post-tensioning bars spaced at 7 inches, with an initial prestress of 1.5 ksi. The deck is post-tensioned together in groups of three to five panels of 9 feet to 11feet in length, depending on location. One side of one span was found to have experienced problems with debonding of the deck's wearing surface. However, no significant problems with the deck itself or the deck joints were found. Some rust was visible, indicating that some joints had leaked at one time, but no other signs of leakage were evident at the time of inspection. The team concluded that the panels were performing properly and that the type of joint used between prestressed panels is satisfactory.

The Seneca Bridge in LaSalle County, Illinois, is seventy years old and consists of 13 spans for a total length of 1510 feet 3 inches. The bridge deck was replaced in 1986 with 6  $\frac{1}{2}$  inches thick precast/prestressed concrete deck panels and a 2-inch cast-in-place concrete overlay. All of the panels were match cast and placed, with epoxy filling the joints between panels. Panel-to-girder shear connections for the approach spans (1 through 5 and 10 through 13) were made using two  $\frac{3}{4}$  x 10 inch bolts in shear pockets. Panels in the interior spans were connected to the girders using four  $\frac{3}{4}$  x 10 inch bolts in each shear pocket. The prestressing of the panels was done using both 1-inch diameter smooth and 1-inch diameter deformed prestressing bars placed at 2-10 inch intervals across the bridge width.

Some of the problems that were found in this deck include random cracking in the approach spans and leakage through the joints of adjacent precast panels. The inspection team attributes this leakage to the use of match cast joints. This type of joint does not allow sufficient surface area for the grout to bond with the precast panels. The leakage is also contributing to the corrosion of the supporting steel structure.

The next state visited by the inspection team was Connecticut, where an inspection was performed on the Waterbury Bridge, which is maintained by the Connecticut Department of Transportation. The six span, 700-foot long bridge was originally constructed in 1965 and reconstructed in 1989. The 27.5 foot wide deck was replaced with full width precast concrete panels that are 8 feet long and 8 inches thick. The deck was topped with a 2 ½ - inch bituminous wearing surface. The panel-to-girder shear connections were made with shear studs and pockets spaced at 2-inch intervals. Each shear pocket contains three 7/8 -inch shear studs. The transverse joints between panels are female-to-female type shear keys that are filled with high strength, non-shrink grout -- (see Figure B5).<sup>(36)</sup>

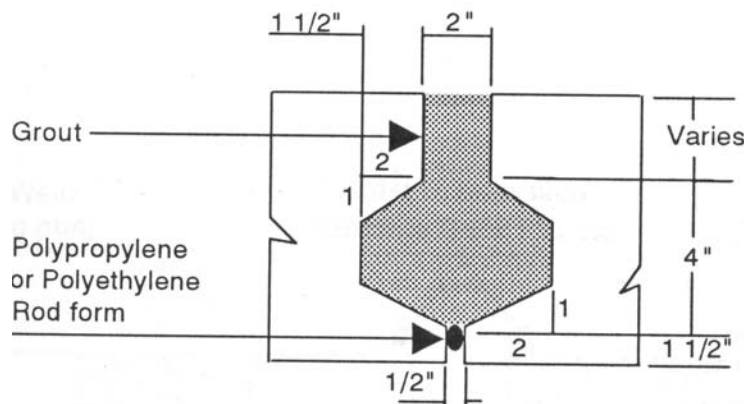

**Figure B5. Typical Female-to-Female Shear Key**

There were no problems found in the deck panels, transverse joints or shear connections. However, consistent vertical cracks were found in the cast-in-place end haunches due to the fast setting characteristics of the concrete that was used. Longitudinal cracks in the haunches were also visible. Despite the cracking in the haunches the inspection team reported that the overall condition of the deck was good and the panels were performing satisfactorily.

In Maryland, the team inspected the William Preston Jr. Memorial Bridge, which was built over the Chesapeake Bay in 1952 (see Figure B6).<sup>(43)</sup> The bridge deck was replaced with 6-inch thick full width precast deck panels and topped with inches of latex modified concrete, cast-in-place. The inspection team found some significant problems in the deck. Diagonal cracking was found on both sides of the deck due to the lack of transverse prestressing strands in the panels. Also, the latex modified concrete didn't



**Figure B6. William Preston Jr. Memorial Bridge over the Chesapeake Bay**

bond above the joints between the precast panels and the superstructure in one location, which caused popouts in the overlay in that area. Another problem they found was substantial leakage through the transverse joints between panels. This was evident by the stains and deposits found on the underside of the panels and by corrosion below the deck. The leakage has been attributed to the type of joint used between the panels. The joint has a closed end at the bottom that does not provide any tolerance for dimensional variations in the casting or placement of the panels. The problematic joints are currently being maintained by patching the joint openings with caulking material.

The team inspected three bridges under the jurisdiction of the New York State Thruway Authority (NYSTA). The first was the Amsterdam Interchange Bridge in Montgomery County, which was built in 1954. The deck replacement, done in 1974, was an experiment that was set up to compare the performance of bolted versus welded shear connections, as well as the durability of precast versus cast-in-place bridge decks. Of the four spans, only one-half of span two was built with precast concrete deck panels. A total of seven panels were used, three with bolted connections and four with welded connections. The partial width precast panels, measuring 8"x4'x22', were placed side by side to span the width of the deck.

Following this project, the use of bolted connections was discontinued in Thruway Authority projects because they found that the bolts cannot approach maximum tension without risking slab breakage.<sup>(26)</sup> Several other problems were found by the team, most of which were localized at the joints. Spalling, longitudinal and transverse cracking and joint leakage were observed with subsequent corrosion of the steel superstructure due to the leakage. A lack of longitudinal post-tensioning seems to be the primary cause of the joint problems. It was noted that although the deck is due for replacement, the performance and durability of the precast span was equivalent to that of the cast-in-place portion of the bridge deck.

The second NYSTA bridge inspected by the team was the Krumkill Road Bridge in Albany County. It is a 50-foot long simple span bridge that carries six lanes of traffic. Welded headed shear studs were used to provide for composite action of the precast deck and steel superstructure. The Harriman Interchange Bridge located in Orange County was the third NYSTA bridge visited by the team from UIC. This three-span structure contains horizontal and vertical curves in its alignment and totals 225 feet in length.

The condition reports for these two bridges were very similar. Reflective cracking in the wearing surface above the transverse joints between panels was observed in both of these structures. Also, spalling of the concrete was found on the top and bottom sides of the panels in each. Again, the biggest contributing factor to the deterioration of both of these decks is thought to be the absence of longitudinal post-tensioning which keeps the transverse joints pulled tight.

## **COST EFFICIENCY OF PRECAST BRIDGE DECK SYSTEMS**

Many factors affect the overall cost of any bridge deck construction or rehabilitation project. Some considerations are inherent to the structure itself such as size of the deck, design loads, traffic volume, geometric, and structural design constraints, specified concrete strength and longitudinal and lateral prestressing requirements. Others are dependent upon the construction environment. For example, site conditions, climate, and material availability all factor into the cost of a project.

Due to the uniqueness of bridge construction and rehabilitation projects, it was not feasible to determine and compare with confidence the cost trends of precast and cast-in-place bridge decks on a national or regional basis. During the course of this research, requests for cost information were sent to various agencies, contractors and consultants. The responses varied widely and many requested additional information and clarification in regard to the specifics of the application. Thus, it was determined that when considering precast versus cast-in-place bridge decks, it is not advisable to approach the economics of design with a “one size fits all” philosophy, rather several alternatives should be considered in order to find the optimal solution given the criteria set forth by the sponsoring agency. That being said, research and past experience have shown that precast concrete bridge deck systems have the potential to save owners and transportation agencies a considerable amount of time and money over conventional cast-in-place deck construction. There have been many projects constructed under various conditions and environments where evidence of superior economic benefits of precast over cast-in-place concrete bridge decks have been documented. The following are a couple examples of such projects.

Early in the 1990’s two overpass structures were built in association with the widening of Texas State Highway 249 near Houston. These structures, both built with partial depth precast deck panels, were the first bridges in the United States to be built with

High Performance Concrete (HPC) substructures and superstructures.<sup>(34)</sup> The partial depth deck panels were used as stay-in-place forms for the cast-in-place portion of the deck. The use of these panels not only sped up construction time but also resulted in a considerable cost savings to the Texas Department of Transportation. The average price for comparable bridges at that time in Texas was \$27 per square foot of deck area. The cost of these bridges was \$24 per square foot, a savings of just over 11percent.<sup>(35)</sup>

At the Austin-Bergstrom International Airport, a 1400-foot long, 17-span bridge provides vehicular and pedestrian access to the upper level of the terminal building. The original design of the structure called for multi-celled box girders to be cast-in-place and post-tensioned. However, after the project was awarded, the winning contractor hired P.E. Structural Consultants to provide value engineering in order to reduce the project cost and earn incentives. The result was a re-designed superstructure that employed precast U-beam girders and partial depth precast deck panels to support the cast-in-place wearing surface. The deck panels are shown in Figure B7.<sup>(17)</sup> The use of precast elements that could be fabricated off site allowed the contractor to use manpower more efficiently and trimmed an estimated two to three months off of the construction schedule. The project was initially awarded at a cost of \$5.2 million. After the value engineering and subsequent development of the precast design, the price dropped to \$4.6 million including the cost of the re-design.<sup>(17)</sup> The cost savings to the project was 11.2 percent.

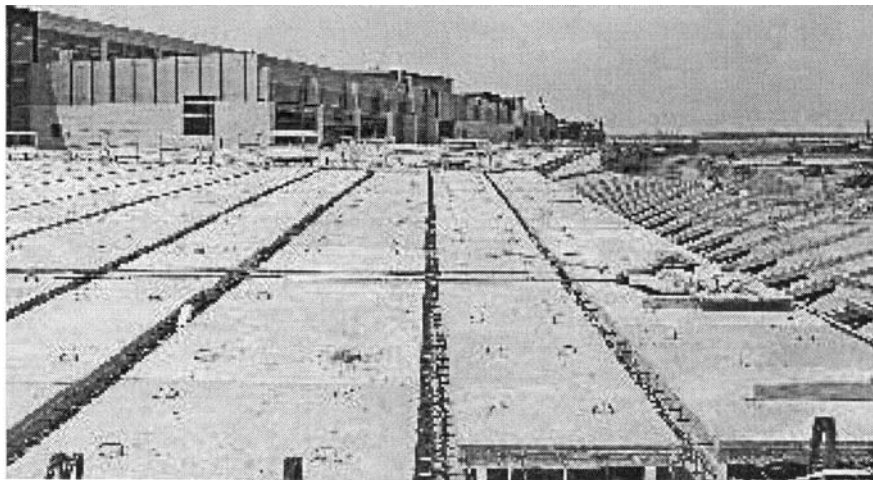

**Figure B7. Stay-in-Place Bridge Deck Forms Supported by U-Beams**

In October of 2002, the American Segmental Bridge Institute (ASBI) published a database containing cost information for segmental bridges built throughout the United States from the early 1970's to the present.<sup>(33)</sup> This document represents a wide variety of bridge designs with varying foundation and superstructure types. See Appendix A for a hard copy of this compilation. The data presented includes application (over water, viaduct or cable-stayed), span length, foundation type, superstructure type, segmental construction method, year bid, location, square footage and cost information adjusted



for time. The following text is an effort to extract representative unit costs for segmental bridges built with precast bridge decks as compared to those built with cast-in-place bridge decks. In the interest of relevance, only bridges bid after 1990 were included in the comparison. Individual bridges of similar size, foundation and application type were selected from the database in order to yield a fair comparison. The selection of bridges and associated information used for this comparison can be found in Tables B1 and B2. See Appendix A for complete details regarding these bridges.

**Table B1. Unit Costs for Segmental Bridges with Cast-In-Place Decks**

<b>Project Name</b>	<b>Year Bid</b>	<b>Cost Per Sq. Ft.</b>	<b>Owner</b>
<b>Acosta Bridge</b>	1990	\$176.95	FDOT
<b>Puyallup River Bridge</b>	1994	\$129.95	WSDOT
<b>Wabasha Street</b>	1995	\$112.00	City of St. Paul
<b>Putnam Street</b>	1998	\$167.49	Washington County
<b>I-895 Over James River</b>	1998	\$208.54	VDOT
<b>Creve Coeur Park Memorial</b>	1999	\$159.68	MHTC
<b>Memorial Causeway</b>	2001	\$112.16	FDOT
<b>SR 87 Arizona</b>	1996	\$145.00	AZDOT
<b>I-93 Viaducts and Ramps</b>	1998	\$152.00	Massachusetts DOT
<b>Average Unit Cost</b>		<b>\$151.53</b>	

**Table B2. Unit Costs for Segmental Bridges with Precast Decks**

<b>Project Name</b>	<b>Year Bid</b>	<b>Cost Per Sq. Ft.</b>	<b>Owner</b>
<b>Wando River Bridge</b>	1995	\$43.55	SCDOT
<b>Bath-Woolwich</b>	1997	\$194.84	Maine DOT
<b>Sailboat Bridge</b>	1998	\$82.33	Oklahoma DOT
<b>Broadway</b>	1998	\$90.61	FDOT
<b>Hathaway Bridge Replacement</b>	2000	\$106.73	FDOT
<b>I-93/I-90 Interchange</b>	1996	\$166.67	Massachusetts DOT
<b>I-25/I-40 Interchange</b>	2000	\$82.79	NMSHTD
<b>C019B1 North of Charles River</b>	1997	\$147.89	Mass. Hwy. Dept.
<b>Average Unit Cost</b>		<b>\$114.43</b>	

From these tables, it can be seen that the data collected for this report by ASBI indicates that designers and builders who are experienced in precast construction can build precast concrete bridge decks for an initial cost that is comparable to if not less than that of a cast-in-place deck. However, the real economy is found in the reduced

construction time and longer service lives associated with precast bridge decks. These advantages of precast over cast-in-place bridge decks stand to reduce user delay costs and increase toll revenue significantly.

With user delay costs that can reach \$100,000 per day or more in certain high traffic areas, it is very important to minimize the amount of time that a bridge and associated roadway are out of service due to construction.<sup>(34)</sup> This is where precast deck components can be extremely valuable. Past bridge deck projects have shown that using precast elements can cut the construction schedule by weeks or even months. In 1998, viaducts on I-287 in New York were replaced using full depth precast panels for the decks. The use of these panels helped to reduce the construction schedule by one year.<sup>(32)</sup> This type of scenario gives an indication of the costs savings to owners that are attainable through the use of precast concrete deck systems.

Full depth precast slabs can extend the service lives of bridge decks beyond the typical service life of a cast-in-place deck. Shrinkage cracking is eliminated in full depth precast slabs by casting them in a controlled environment two to three months before they are delivered to the project site.<sup>(32)</sup> This reduces the water penetration that leads to corrosion of the reinforcing steel. For this reason precast panels, are expected to increase the service lives of bridge decks by 10-15 years beyond cast-in-place bridge decks. When High Performance Concrete is used in the panels, service life will be even longer. Thus, life cycle costs of bridge decks can be greatly reduced, resulting in long-term savings for the owner.

## **INNOVATIONS IN DESIGN AND CONSTRUCTION**

### **High Performance Concrete**

There are two elements that comprise a typical high performance concrete bridge. The first is a total precast bridge system such as beams cast with integral concrete decks, full depth precast panels or segmental bridge components.<sup>(21)</sup> These components can significantly increase the speed of bridge deck construction. The other element is high performance concrete (HPC), which will be the focus of this section. High performance concrete uses the same standard materials as regular concrete but the proportions and gradations are engineered to give the concrete a higher strength and increased durability. The higher strength allows for greater span lengths between piers and/or girders which reduces construction time and cost. The increased durability of HPC means that bridges will last longer and effectively reduces their life cycle cost.

In general terms, HPC is a concrete mix that offers a 28-day compressive strength of at least 8000 psi. However, the FHWA has developed the following eight criteria, four for strength and four for durability, to classify high performance concrete.<sup>(27)</sup>

- Freeze/thaw durability
- Scaling resistance
- Abrasion
- Chloride penetration
- Strength
- Elasticity
- Shrinkage
- Creep

High performance concrete can be used efficiently in many situations. Its resistance to chloride penetration makes it ideal for use in cold weather climates where deicing materials are used frequently. The strength of HPC allows designers to maximize clearances in dimensionally restricted situations. The durability of HPC can extend the service lives of bridges, which makes it a good candidate for use even in structures that don't require the higher strength it provides.

Pushing the limits even farther, researchers are developing experimental concrete mixes with far greater strengths than the high performance concretes being used today. This category of concrete is appropriately called Ultra-High Performance Concrete (UHPC). The materials used in UHPC are fine sand, quartz flour, and 1/2" long steel or organic fibers. These materials provide the mix with a higher tensile strength to complement the compressive strengths of up to 30,000 psi, which are now attainable.<sup>(27)</sup> Ultra-High Performance Concrete was first developed in 1995, by Bouygues S.A. in Paris. The material is now being produced by some United States precasters and is being tested in Virginia at the Turner-Fairbank Highway Research Center.

The high strength and quick setting characteristics of UHPC require that precasters modify their operations to make efficient use of the material. The shapes and dimensions of bridge components must also be re-designed to take advantage of the strength of UHPC and to make its use cost effective. The Virginia Department of Transportation is considering the design and construction of a bridge using UHPC within the next two years, pending the results of laboratory testing.

### **Fiber Reinforced Polymers**

Another innovation in bridge deck construction is the use of fiber reinforced polymers (FRP) as an alternative to steel reinforcement. Fiber reinforced polymers are highly resistant to corrosion, unlike steel rebar. In cold weather climates where deicing salts are frequently used, FRP could significantly increase the service lives of bridge decks.<sup>(19)</sup> Another advantage of using FRP reinforcement is that the overall weight of the bridge deck can be significantly reduced, which results in a smaller dead load that the superstructure must support.

The National Composites Center (NCC) is an Ohio organization that advocates the use of composite construction materials. The NCC organized a program titled "Project 100" that was intended to coordinate the replacement of 100 traditional bridge decks with FRP deck panels within a six-year period. Under this program, the state of Ohio was to fund the difference between the cost of a traditional bridge deck and that of an FRP deck for each project considered. This difference can be over twice the cost of a traditional deck. However, the NCC has since widened its focus to the application of FRP to total bridge systems while settling for a smaller number of deck replacements.

As of February 2001, a total of fifteen FRP bridge decks had been completed or were scheduled for construction.<sup>(18)</sup>

The first of these decks, in fact the first FRP reinforced bridge deck built in the U.S., is located in Hamilton County, Ohio.<sup>(18)</sup> This two-lane bridge measures 43 feet long by 30 feet wide. The deck consists of seven FRP reinforced panels and weighs one-fifth as much as a traditional deck. The light weight of the panels allowed all seven to be delivered to the site on one truck. The placement of the panels was done using leveling screws and shear studs. The space between the bottom of the panels and the top of the girders was then filled with grout. The process is analogous to the placement of full depth precast concrete panels with steel reinforcement.

At twice the cost of a traditional deck, the significantly higher cost of FRP bridge decks may be hindering their widespread acceptance by transportation agencies in the U.S. However, FRP reinforced decks are expected to last up to 100 years, which would make its life cycle cost at least comparable to that of a traditional deck.<sup>(18)</sup> Also, the smaller dead loads imparted by FRP panels could translate into cost savings in the design and construction of bridge superstructures.

### **Precast Through-Girder Bridges**

The Sedley Bridge is a unique bridge designed by engineers in Indiana and consists of an entirely precast and prestressed superstructure. The specific design challenges that inspired the design were a need for increased vertical clearance while maintaining a low enough elevation to allow the deck to tie into a state highway running perpendicular to it at a lower grade. These challenges were met by using a precast “through-girder” bridge design -- see Figure B8.<sup>(6)</sup> Exterior precast concrete box girders were used to support full depth precast deck panels, resulting in a bridge profile that is only 14 inches from the top of the deck to the bottom.

The entire superstructure supporting the deck consists of two longitudinal precast box girders, each running above and outside the edges of the deck. Temporary wood shelves fastened to the bottom of the beams were used to support the deck panels during their initial placement. Shear resistance in the deck is provided by shear keys cast along the inner bottom edge of each precast box girder. After all of the precast panels were installed, the gaps between the panel edges and beams, as well as the shear keys, were filled with grout. Then transverse and longitudinal prestressing of the full depth precast panels was performed.

The low profile of this bridge was made possible by the precast through-girders and resulted in a significant cost savings to the state of Indiana. Not only did this design better suit their need for maximum clearance, but it cost almost \$1 million less to build than a traditional steel girder/concrete deck structure, which was a preliminary consideration.<sup>(6)</sup> Much of the cost savings were realized in the reduced scope of the bridge approach work due to the minimization of the elevation difference between the top of the deck and the existing approaches. The low profile also allowed the required span length to be shorter, reducing the material needed for the girders and bridge deck.

Also, the entirely precast superstructure allowed the use of construction procedures that minimized the environmental impact and allowed the railroad to remain operational for the duration of the project.



**Figure B8. Through Girder Bridge (Sedley Bridge, Indiana)**

## **DISCUSSION AND RECOMMENDATIONS**

As the demand increases for faster construction schedules and longer service lives of bridges, the technology of precast bridge deck construction will become invaluable to the surface transportation industry. Several of the current design and construction methods have been presented in this paper including total precast superstructures, segmental construction and precast concrete bridge deck panels, both full and partial depth.

Condition studies of precast bridge decks indicate that they have performed equally as well, if not better than their cast-in-place counterparts. In many cases, bridges built with precast components have well surpassed their designed service lives. That is not to say that the technology is flawless. As with any new technology, there have been problems that were discovered and subsequently addressed, particularly in regard to segmental and partial depth precast panel construction. It has been concluded that segmental bridge construction requires quality workmanship and thorough inspection and testing in order to insure proper bonding of the post-tensioning strands and composite action of the precast segmental units. Testing has shown that the problems associated with partial depth precast panels in the past can be mitigated by designs that provide for transverse and longitudinal continuity through adjacent panels.

On several bridge deck projects, substantial cost savings have been documented and attributed to the use of precast bridge deck components over cast-in-place decks due to the reduction of formwork and manual labor. The reduced construction time and potential for longer service lives associated with precast bridge decks add to their cost efficiency.

Finally, there are several design and construction innovations pertaining to precast bridge decks that are being studied but have not been widely implemented as of yet. Some examples are High Performance Concrete (HPC), Ultra-High Performance Concrete (UHPC) and Fiber Reinforced Polymer (FRP) composite panels. Through increased strength and resistance to corrosion, these innovations have the potential to increase performance and greatly extend the service lives of bridge decks beyond what is achievable through conventional construction methods.

## REFERENCES

1. Design of Modern Highway Bridges, Taly, Narendra, Dept. of Civil Engineering, California State University, Los Angeles, copyright 1998.
2. [www.new-technologies.org/ECT/Civil/itbeam.htm](http://www.new-technologies.org/ECT/Civil/itbeam.htm), web site accessed 6/18/02.
3. [www.enr.com/news/enrtech20.asp](http://www.enr.com/news/enrtech20.asp), web site accessed 6/18/02.
4. [www.cse.polyu.edu.hk/~ctbridge/beam/beam08.htm](http://www.cse.polyu.edu.hk/~ctbridge/beam/beam08.htm), web site accessed 6/18/02.
5. [www.portcement.org/br/bridges\\_segmental.asp](http://www.portcement.org/br/bridges_segmental.asp), web site accessed 6/18/02.
6. "Through-Girder Bridge Offers Low Clearance", Endicott, Wayne A., Ascent, Precast/Prestressed Concrete Institute Magazine, pp. 34-36.
7. [www.cianbro.com/press/newsview.asp?sid=791](http://www.cianbro.com/press/newsview.asp?sid=791), web site accessed 7/15/02.
8. [www.bridgebuildermagazine.com/basculer/fort.html](http://www.bridgebuildermagazine.com/basculer/fort.html), web site accessed 7/15/02.
9. [www.exodermic.com/over.html](http://www.exodermic.com/over.html), web site accessed 7/15/02.
10. [www.steel.org/infrastructure/bridges/hpsconcepts/part2b\\_2.htm](http://www.steel.org/infrastructure/bridges/hpsconcepts/part2b_2.htm), web site accessed 6/18/02.
11. [www.aashtotiq.org/focus\\_technologies/prefab\\_elements/elements.stm](http://www.aashtotiq.org/focus_technologies/prefab_elements/elements.stm), web site accessed 11/21/02.
12. [www.ceworld.org/ceworld/Presentations/Structures/Hussanain](http://www.ceworld.org/ceworld/Presentations/Structures/Hussanain), web site accessed 11/21/02.
13. "Performance of Prestressed Concrete Bridges in the United States – The First 40 Years", Dunker, Kenneth F. and Rabbat, Basile G., PCI Journal (May/June 1992), Vol. 37, No. 3, pp. 47-64.
14. [www.pccny.org/assoc/newsltr/june98/6ful.htm](http://www.pccny.org/assoc/newsltr/june98/6ful.htm), web site accessed 11/21/02.

15. Construction of Bridge Decks with Precast, Prestressed Concrete Deck Planks, Volle, Tessa H., Illinois Department of Transportation Bureau of Materials and Physical Research (April 2002).
16. "Sulfate Attack On Concrete In Simulated Cast-In-Situ and Precast Situations", Kumar, Sunil and Rao, C.V.S. Kameswara, Cement and Concrete Research (1995), Vol. 25, No. 1, pp. 1-8.
17. "Precast Concrete Alternate Provides Unique Solution for Airport Terminal Bridge", Powell, Lisa Carter and Powell, David W., PCI Journal, (March-April 2000), pp. 18-25.
18. "Ohio Bridge Deck Replacement Advances Use of FRP", Fortner, Brian, Civil Engineering Magazine (February 2001), Vol. 71, No. 2.
19. "FRP Improves Bridge Deck Life", Deitz, David Holman, Better Roads (November 2002).
20. "Prefabricated Bridge Elements and Systems: A Winning Idea", U.S. Department of Transportation, Federal Highway Administration, Focus, (May 2002)
21. "Group Promotes Benefits of High Performance Concrete Bridges", Rabbat, Basile G., Ascent Magazine, [www.pci.org/search\\_list.cfm?key=d:\servers\pci\root\htdocs\markets\bridges\rabbat.cfm&url=http://www.pci.org/markets/bridges/rabbat.cfm](http://www.pci.org/search_list.cfm?key=d:\servers\pci\root\htdocs\markets\bridges\rabbat.cfm&url=http://www.pci.org/markets/bridges/rabbat.cfm), website accessed September 19, 2002.
22. "Durability of Precast Segmental Bridges", NCHRP Web Document 25, Project 20-7/Task 92, <http://books.nap.edu/html/HCHRP15/chapters.html>, website accessed February 11, 2002.
23. "Fiber reinforced polymer composites for the superstructure of a short-span rural bridge", Alampalli, S. et al., Composite Structures 58 (2002) pp. 21-27.
24. "Rehabilitation and field testing of an FRP bridge deck on a truss bridge", Alampalli, S. and Kunin, J., Composite Structures 57 (2002) pp. 373-375.
25. "The Effect of Precast Concrete Planks on Shear Connector Strength", Moy, S. S. J. and Tayler, C., J. Construct. Steel Res. (1996) Vol. 36, No. 3, pp. 201-213.
26. "Field Performance of Full Depth Precast Concrete Panels in Bridge Deck Reconstruction", Issa, Mohsen A., et al., PCI Journal (May-June 1995), pp. 82-108.
27. "New Techniques Enhance High-Performance Precast Bridges", Keenan, Andrew J., Better Roads (August 2002).

28. "Making the Most of HPC", Podolny Jr., Walter, Civil Engineering Magazine (February 2001), Vol. 71, No. 2.
29. "Full Scale Bridge Puts CFRP Reinforcement to the Test", Brown, Jeff L., Civil Engineering Magazine (July 2002), Vol. 72, No. 7.
30. "NUDECK – A New Prestressed Stay-In-Place Concrete Panel for Bridge Decks", Badie et al., Civil Engineering Department, University of Nebraska-Lincoln, 1998 Transportation Conference Proceedings.
31. "Construction Procedures for Rapid Replacement of Bridge Decks", Issa et al., Concrete International (February 1995).
32. "Full depth bridge deck systems gain acceptance by cutting schedules and extending service life", Precast Concrete Association of New York, Inc. Monthly Newsletter (January 1999), Vol. 10, No. 1.
33. "American Segmental Bridge Institute Cost Data", American Segmental Bridge Institute (October 22, 2002), [www.asbi-assoc.org/pdf/cost\\_data02.pdf](http://www.asbi-assoc.org/pdf/cost_data02.pdf), website accessed January 12, 2003.
34. "Prefabrication Minimizes Traffic Disruptions", Medlock et al., Bridge Views (May-June 2002), No. 21.
35. [www.aashtotig.org/focus\\_technologies/prefab\\_elements/video\\_clips/](http://www.aashtotig.org/focus_technologies/prefab_elements/video_clips/), website accessed January 12, 2002.
36. "Survey and Analysis of Full Depth Precast Prestressed Concrete Panels for Bridge Deck Replacement", Idriss, Ahmad-Talal, University of Illinois-Chicago (1993).
37. "Segmental and Cable-Stayed Bridges", Figg Jr., Eugene C., Concrete International (June 2002), Vol. 24, No. 6.
38. [www.nationalbridgeinventory.com](http://www.nationalbridgeinventory.com), website accessed June 18, 2002.
39. [www.asbi-assoc.org/project\\_sum02\\_hathaway.html](http://www.asbi-assoc.org/project_sum02_hathaway.html), website accessed June 18, 2002.
40. "Precast Concrete Elements for Transportation Facilities", Transportation Research Board, Washington D.C., National Cooperative Highway Research Program (1978), Vol. 53.
41. "Precast Concrete Deck Modules for Bridge Deck Reconstruction", Slavis,



Charles, Editor: Herman, Scott C., Transportation Research Board, Transportation Research Record: Segmental and System Bridge Construction; Concrete Box Girder and Steel Design (1982), Vol. 871.

42. [www.modjeski.com/projects/servproj/bayview.htm](http://www.modjeski.com/projects/servproj/bayview.htm), website accessed February 9, 2003.
43. [www.mdarchives.state.md.us/msa/mdmanual/01glance/html/bridges.html](http://www.mdarchives.state.md.us/msa/mdmanual/01glance/html/bridges.html), website accessed February 9, 2003.

## **BIBLIOGRAPHY**

1. Eckel, D. A. (1998). A theoretical and experimental study of the behavior of Sandwich bridge decks composed of composite materials. Newark, Del., University of Delaware Center for Composite Materials.
2. Dietsche, J. S. (2002). Development of material specifications for FRP structural elements for the reinforcing of a concrete bridge deck.
3. Dayton Superior Canada, L. Bridge Deck Forming Handbook.
4. Creazza, G. and M. Mele (1991). Advanced problems in bridge construction.
5. Cope, R. J. (1987). Concrete bridge engineering : performance and advances.
6. London ; New York, NY, USA, Elsevier Applied Science ; Sole distributor in the USA and Canada Elsevier Science Pub. Co.
7. Conference on Cathodic Protection of Reinforced Concrete Bridge Decks (1985) : (San Antonio Texas), National Association of Corrosion Engineers., et al. (1985). Cathodic protection of reinforced concrete bridge decks : proceedings of the Conference on Cathodic Protection of Reinforced Concrete Bridge Decks held in San Antonio, Texas, February 12-13, 1985. Houston, Texas, National Association of Corrosion Engineers.
8. Claybaugh, B. G. and University of Pittsburgh. School of Engineering (2002). Experimental Investigation into the Fatigue Response and Ultimate Strength Performance of Concrete Filled Grid Bridge Decks. Pittsburgh, PA, University of Pittsburgh.
9. Chamberlin, W. P. and New York (State). Engineering Research and Development Bureau. (1990). Performance and service life of low-slump-concrete bridge deck overlays in New York. Albany, N.Y., Engineering Research and Development Bureau New York State Dept. of Transportation.

10. Borlin, K. A. (2001). Bridge deck design accounting for girder deflections, arching action and punching shear capacity: xi, 123 pp.
11. Bocchieri, W. J., J. W. Fisher, et al. (1998). Williamsburg Bridge replacement
12. Orthotropic deck as-built fatigue test. Bethlehem, Pa., Lehigh University ATLSS.
13. Bettigole, N. H. and R. Robison (1997). Bridge decks : design, construction, rehabilitation, replacement. New York, ASCE Press.
14. Barker, R. M. and J. A. Puckett (1997). Design of highway bridges : based on AASHTO LRFD, bridge design specifications. New York, John Wiley.
15. Al-Zaid, R. Z. (1986). Fatigue Reliability of Prestressed Concrete Girder Bridges (Analysis, Composite Structures, Cracking).
16. Alampalli, S. and New York (State). Transportation Research and Development Bureau (2001). Correlation between bridge vibration and bridge deck cracking : a qualitative study. Albany, N.Y., Transportation Research and Development Bureau New York State Dept. of Transportation.
17. ACI Committee 345. and American Concrete Institute (1982). Standard Practice for Concrete Highway Bridge Deck Construction ( ACI 345-82). Detroit, Mich., American Concrete Institute.
18. Hanna, A. S. (1999). Concrete formwork systems. New York, Marcel Dekker.
19. Hambly, E. C. (1991). Bridge deck behaviour. London, E & FN Spon ; Van Nostrand Reinhold.
20. Gerwick, B. C. (1993). Construction of prestressed concrete structures. New York, Wiley.
21. Founas, M. (1989). Deformations and Deflections of Partially Prestressed Concrete T-Beams under Static and Random Amplitude Fatigue Loading.
22. El-Hor, H. H. (1995). Serviceability criteria in prestressed concrete bridge girders.
23. Kontopanos, P. P. and Massachusetts Institute of Technology, Department of Civil and Environmental Engineering (2001). Fiber Reinforced Polymer Bridge Deck Panels: 75 pp.
24. Kaczinski, M. R. and Lehigh University. Advanced Technology for Large Structural Systems Center (1997). Williamsburg Bridge Orthotropic Deck Fatigue Test. Bethlehem, Pa., Lehigh University ATLSS.

25. Jackson, D. R. and United States. Federal Highway Administration. Region 15 (1978). Bridge deck evaluation techniques. Arlington, Va., Distributed by U.S. Department of Transportation, Federal Highway Administration, Region 15.
26. Iszauk, S. I. (1998). The use of bolts as shear connectors in precast bridge deck: xvi, 74 pp.
27. Hurst, M. K. (1998). Prestressed concrete design. London ; New York, E&FN Spon.
28. Hurd, M. K. and ACI Committee 347--Formwork for Concrete. (1995). Formwork for concrete. Detroit, Mich., American Concrete Institute.
29. Highway Innovative Technology Evaluation Center (U.S.) and Civil Engineering Research Foundation. (1996). Evaluation findings : the segmental concrete channel bridge system. [New York], American Society of Civil Engineers. Harajli, M. H. (1985). Deformation and Cracking of Partially Prestressed Concrete Beams under Static and Cyclic Fatigue Loading (Deflection).
30. Noh, J. (2001). Reliability analysis of fiber-reinforced polymeric bridge deck: xxii, 213 pp.
31. Nawy, E. G. (2003). Prestressed concrete : a fundamental approach. Upper Saddle River, NJ, Prentice Hall.
32. Nardon, J. D. (1996). Bridge and structure estimating. New York, McGraw-Hill.
33. Naaman, A. E., J. E. Breen, et al. (1990). External prestressing in bridges. Detroit, Mich. (P.O. Box 19150, Redford Station, Detroit 48219), American Concrete Institute.
34. Menn, C. and P. Gauvreau (1990). Prestressed concrete bridges. Basel [Switzerland] ; Boston, Birkhäuser Verlag.
35. Maser, K. R., Massachusetts Institute of Technology. Center for Transportation Studies., et al. (1990). New technology for bridge deck assessment. Cambridge, MA Springfield, Va., Center for Transportation Studies Massachusetts Institute of Technology; National Technical Information Service [distributor].
36. Maret, D. E., Nebraska. Dept. of Roads., et al. (1984). Bridge deck condition survey program. Washington, D.C., Federal Highway Administration Demonstration Projects Division.
37. Kranakis, E. (1997). Constructing a Bridge: An Exploration of Engineering

38. Peurifoy, R. L. and G. D. Oberlender (1996). Formwork for concrete structures. New York, McGraw-Hill.
39. Park, S. Y. (1997). Shear behavior of prestressed concrete beams using fiber reinforced plastic tendons.
40. Palau. Office of Planning and Statistics. (1998). Report on the 1997 bridge survey of population, housing, and expenditures. Palau, Office of Planning and Statistics.
41. O'Brien, E. J., D. L. Keogh, et al. (1999). Bridge deck analysis. London ; New York, E & FN Spon.
42. O'Brien, E. J. and A. Dixon (1994). Reinforced and prestressed concrete design : the complete process. Harlow, England New York, Longman Scientific & Technical; Copublished in the United States with J. Wiley.
43. Nukala, P. K. V. V. A study on horizontal shear strength of stay-in-place precast prestressed bridge deck panels: xviii, 237.
44. Tabsh, S. W. (1990). Reliability-Based Sensitivity Analysis of Girder Bridges (Bridges).
45. Spratlin, M. and University of Alberta. Dept. of Civil and Environmental Engineering. (2001). Influence of design decisions on concrete bridge deck deterioration.
46. Roddis, W. M. K. and Massachusetts Institute of Technology. Dept. of Civil Engineering. (1987). Concrete bridge deck assessment using thermography and radar: 272 pp.
47. Radabaugh, R. D. Investigation of early age bridge deck cracking: xvi, 159.
48. Prenger, H. B. and Maryland. State Highway Administration. (1992). Bridge deckcracking. [Baltimore, Md.] [Springfield, VA, Maryland Dept. of Transportation State Highway Administration ; Available through the National Technical Information Service.
49. Precast/Prestressed Concrete Institute. (1992). PCI design handbook : precast And prestressed concrete. Chicago, Precast/Prestressed Concrete Institute.
50. Podolny, W. and J. M. Muller (1982). Construction and design of prestressed concrete segmental bridges. New York, Wiley.
51. Wills, J., M. A. Crisfield, et al. (1989). Numerical analysis of a half-scale prestressed-beam and slab bridge deck. Crowthorne, Berkshire, Transport and Road Research Laboratory.

52. Whiting, D., United States. Federal Highway Administration., et al. (1999). Rehabilitation of prestressed concrete bridge components by non-electrical (conventional) methods. McLean, VA[Springfield, Va., Federal Highway Administration ;Available through the National Technical Information Service.
53. United States. Federal Highway Administration. Demonstration Projects Division. (1986). Precast modular concrete bridge deck panels. Washington, D.C., U.S. Dept. of Transportation Federal Highway Administration Demonstration Projects Division.
54. United States. Dept. of Transportation and United States. Congress. House. Committee on Public Works and Transportation (1993). The Status of the nation's highways, bridges, and transit conditions and performance : report of the Secretary of Transportation to the United States Congress, pursuant to Section 307(h) of Title 23, United States code, and Section 308(e) of Title 49, United States code. Washington, U.S. G.P.O.
55. United States. Congress. House. Committee on Transportation and Infrastructure. (1999). William H. Natcher Bridge report (to accompany H.R. 1162) (including cost estimate of the Congressional Budget Office). [Washington, D.C., U.S. G.P.O.
56. United States. Congress. House. Committee on Science and Technology. Subcommittee on Transportation Aviation and Communications. (1979). Potholes and bridge deck corrosion : hearing before the Subcommittee on Transportation, Aviation, and Communications of the Committee on Science and Technology, U.S. House of Representatives, Ninety-sixth Congress, first session, March 19, 1979. Washington, U.S. G.P.O.
57. Troitsky, M. S. (1990). Prestressed steel bridges : theory and design. New York, N.Y., Van Nostrand Reinhold.
58. Tadros, M. K., M. C. Baishya, et al. (1998). Rapid replacement of bridge decks. Washington, D.C., National Academy Press

## **APPENDIX B**

### **Appendix B1: American Segmental Bridge Institute Cost Data**

In October of 2002, the American Segmental Bridge Institute (ASBI) published a database containing cost information for segmental bridges built throughout the United States from the early 1970's to the present. This document represents a wide variety of bridge designs with varying foundation and superstructure types. The data presented for each bridge includes the application (over water, viaduct or cable-stayed), span length, foundation type, superstructure type, construction method, year bid, location, square footage and cost information adjusted for time. The data is available on-line at [www.asbi-assoc.org/menu.cfm?dir=cost\\_data&page=index](http://www.asbi-assoc.org/menu.cfm?dir=cost_data&page=index). It is printable in landscape format and is reproduced on the following pages.



October 22, 2002

AMERICAN SEGMENTAL BRIDGE INSTITUTE  
COST OF CONCRETE SEGMENTAL BRIDGES

TYPE OF BRIDGE	PROJECT NAME	SPAN RANGE	TYPE OF PILE	C.I.P. P.C. OTHER	SPAN/BALANCE OTHER	OVERLAY GRINDING GROOVING	YEAR BID	SPECIAL CONDITION	BRIDGE WIDTH	TOTAL COST OF PROJECT	TOTAL COST OF BRIDGE	SG. FT. OF BRIDGE	COST PER SQ. FT.	YWE ADJUST COST	LOCATION	OWNER	DESIGNER	CONTRACTOR
BRIDGE OVER WATER	Seabreeze Bridge	250'	24" P.C.	P.C.	Balanced Cantilever	Grinding & Grooving	1995	Value Engineering	50'	\$ 24.0 M	\$ 20.5 M	225,824	\$90.80	\$99.77	Daytona Beach Florida	FDOT	Parsons Brickerhoff / Finley McIlroy	GLF Construction Corporation
BRIDGE OVER WATER	Bath-Woolwich	200'-420'	8' Diameter Drilled Shaft	P.C.	Balanced Cantilever		1997		82'	\$ 46.6 M	\$ 42.1 M	221,647	\$190.00	\$194.04	Bath, Maine	Maine DOT	Ripp Engineering	Flabon
BRIDGE OVER WATER	Sailboat Bridge	122'	108" Drilled Shaft	P.C.	Span/Span		1998		2 @ 41'-4"	\$ 20.4 M	\$ 20.4 M	252,052	\$80.90	\$82.33	Delaware County Grand Lake, Oklahoma	OK DOT	Ripp Engineering	Traylor Bros.
BRIDGE OVER WATER	Pulham St.	182' to 322' 182'	72" Drill Shaft	C.I.P.	Balanced Cantilever	Microsilica W5	1998		70'	\$ 11.1 M	\$ 7.9 M	45,000	\$164.56	\$167.49	Marletts Ohio	Washington County	HNTB/Finley McIlroy	Kokosing
BRIDGE OVER WATER	Evans Cray St	180'	30" PC	P.C.	Span/Span	Class V Grinding & Grooving	1998	Slip Impact Shallow Water	49'-4"	\$30.75 M	\$ 25.65 M	294,380	\$87.84	\$89.20	Shuak Florida	FDOT	Belwenger, Hoch & Assoc. Finley McIlroy	PCL Civil Constructors
BRIDGE OVER WATER	Broadway	164' to 262'	48" & 60" Drill Shafts	P.C. Variable Depth	Balanced Cantilever	Class V Grinding & Grooving	1998	Fender System Collarbars & Seal in Pile Architectural Features	46.4'	\$ 30.9 M	\$ 25.9 M	291,189	\$89.04	\$90.61	Daytona Beach Florida	FDOT	Ripp Engineering	Mueser Martz
BRIDGE OVER WATER	I-95 Bridge Over James River	387' 615' 354'	Drilled Shafts	C.I.P.	Balanced Cantilever	Microsilica	1998	Over River	57'	\$ 125.90 M	\$ 47.61 M	232,341	\$204.62	\$208.54	Richmond Virginia	VDOT	Parsons Brickerhoff	Conddle America, Inc.
BRIDGE OVER WATER	Creve Coeur Park Memorial	165' to 469'	H-Piles Spread Foot. Drilled Shafts	C.I.P.	Balanced Cantilever	Silica Fume Concrete Wearing Surface	1999		182'	\$ 73.5 M	\$ 73.5 M	460,105	\$159.66	\$159.66	St. Louis Missouri	Missouri Highway and Transportation Commission	Sverdrup Civil	Walker & SO
BRIDGE OVER WATER	Highway Bridge Replacement	178' to 330'	60" Cylinder Piles	P.C.	Balanced Cantilever	Grinding and Grooving	2000	Design-Build	800.5'	\$ 61.5 M	\$ 61.5 M	576,241	\$106.73	\$106.73	Panama City Florida	Florida DOT	HNTB	Grande Const.
BRIDGE OVER WATER	Memorial Causeway	166' to 360'	64" Drilled Shafts	C.I.P.	Balanced Cantilever	High Level Variable Depth Grinding and Grooving	2001	VECP	112' 7"	\$ 47.62 M	\$ 29.54 M	263,445	\$112.16	\$112.16	Clevesville Florida	Florida DOT	HDR and JWB/EARTHTECH	PCL
BRIDGE OVER WATER	Ringling Bridge Replacement	300'	66" Drilled Shafts	CIP-Pre Seg PC-Over Seg	Balanced Cantilever	Grinding and Grooving	2001		106'	\$ 76.0 M	\$ 56.0 M	326,255	\$170.60	\$170.60	Sarasota Florida	Florida DOT	JMI	PCL
BRIDGE OVER WATER	Royal Park Bridge	59' to 131'	Drilled Shafts	CIP	Balanced Cantilever	Grinding and Grooving	2001	Bascule Main span Twin Bridges	42' 9" x 2	\$ 52.0 M	\$ 20.27 M	72,534	\$279.52	\$279.52	West Palm B. Florida	Florida DOT	E.C. Driver	Balfast Nedam

279.52



**AMERICAN SEGMENTAL BRIDGE INSTITUTE**  
**COST OF CONCRETE SEGMENTAL BRIDGES**

TYPE OF BRIDGE	PROJECT NAME	SPAN RANGE	TYPE OF PILE	C.I.P. P.C. OTHER	SPAN/BALANCE OTHER	OVERLAY/GRINDING/GROOVING	YEAR BID	SPECIAL CONDITION	BRIDGE WIDTH	TOTAL COST OF PROJECT	TOTAL COST OF BRIDGE	SG. FT. OF BRIDGE	COST PER SG. FT.	LOCATION	OWNER	DESIGNER	CONTRACTOR	SUBMITTED BY
BRIDGE OVER WATER	Valley City Eagles Bridge	175' to 550'	Steel H	C.I.P.	Lift Span & Balanced Cantilever	Asphalt	1985		42'	\$ 24.0 M		274,386	\$87.46	Valley City Illinois	Illinois DOT	HNTB	Shappert	M. Miller
BRIDGE OVER WATER	Centennial Memorial Bridge	540'	Spread Footing	C.I.P.	Balanced Cantilever	Latex	1985							Cour d'Alene Idaho	Idaho DOT	HNTB	Messman	M. Miller
BRIDGE OVER WATER	Port of Miami	95'-195'	30" PC	P.C.	Balanced Cantilever	Grinding & Grooving	1988-89	Ship Impact	53'-2"	\$ 40.0 M	\$ 25.60 M	268,105	\$95.46	Miami Florida	Port of Miami, Dade County & FDOT	Belawesger, Hoch & Assoc.	Misener Marine and Volker Steinhilber	L.M. Vargas
BRIDGE OVER WATER	West Seattle Swing Bridge	Main sp. 480' Tall sp.s 178' Approaches 108' - 142'	Pipe Pile	C.I.P.	Balanced Cantilever	Overlay	1989	Double Leaf Swing Bridge	51'	\$ 34.3 M		90,000	\$361.11	Seattle WA	City of Seattle	WSS-2 Design Team	Kiewit-Global JV	Paul Guntz
BRIDGE OVER WATER	Baldwin Bridge	177' - 275'		P.C.	Balanced Cantilever	Overlay	1989		85'-0" 76'-11"	\$ 93.8 M	\$ 93.8 M	411,935	\$227.71	Old Saybrook Connecticut	Connecticut DOT	Pamona Steckerhoff	Perini/PCUD&G	P. Hatfield
BRIDGE OVER WATER	Acosta Bridge	220/260' 630' 275/160'	60" dia. Drill Shafts	C.I.P.	Balanced Cantilever	Grinding & Grooving	1990	Existing Bridge Underwater Protection	75'-8" Varies	\$ 48.3 M	\$ 44.1 M	250,000	\$176.55	Jacksonville Florida	FDOT	DRC	Recchi America, Inc.	Recchi
BRIDGE OVER WATER	Puyallup River Bridge	285-445' 445-265'	2 Piers 10' drilled shaft 3 piers 30" CIP Piles	C.I.P. Haunch Segmental	Balanced Cantilever	Latex Modif Concrete Overlay after Grinding	1994	1 Span over RR Track, 2 Spans Over Sewage Plant, 1 span over River	74'	\$ 21.7 M	\$ 14.04 M For Sep. spans Only	100,040	\$129.95	Tacoma Washington	WSDOT	WSDOT	Walker & SCI	J.A. Weigel
BRIDGE OVER WATER	Roosevelt Bridge	196' to 260'	30" P.C. Piles	Pier Segments Cast in Place Typ. Segments Precast	Balanced Cantilever	Grinding & Grooving	1994	Some microsilica concrete Over 2 RR	61'	\$ 54.0 M	\$ 43.6 M	552,533	\$79.40	Stuart Florida	FDOT	LoBeano, Armitage & Associates	Recchi America, Inc.	Ch. Cross
BRIDGE OVER WATER	Presumpscot Falls River Bridge	180 Ft. Arch 2@42'-6@25' 2@ 42' Superstructure	Spread Footing	C.I.P.	Cabled Stayed Cantilever	Bimolecular Paving with Membrane	1994	Contractor redesign erection scheme to stayed segmental for arch.	36'	\$ 2.6 M Including Appr Span	\$ 2.6 M	13,248	\$196.25	Near Falmouth, Maine	Maine DOT	Main DOT	Clembro Corp.	Finley McHenry T. Skeltrack
BRIDGE OVER WATER	Santa Rosa Bay Bridge	140'	P.C. 30"	P.C.	Span/Span	None	1995	P.C. Piers No Epoxy	43'-1"	\$ 53.6 M	\$ 39.5 M	787,718	\$50.15	Garcon Point Florida	Santa Rosa Bridge Authority	Flag Engineering	Odebrecht-Metric J.V.	ASBI
BRIDGE OVER WATER	Wabasha Street	230' to 400'	Steel H 14 x 59	C.I.P.	Balanced Cantilever		1995	5% Grade Limited Access	47'-8"	\$ 26.0 M	\$ 14.6 M	130,357	\$112.00	St Paul Minnesota	City of St. Paul	Flag Engineering	Lunda Construction	T. DeLaven
BRIDGE OVER WATER	Wando River Bridge	150' 300/400/050'	Steel H & P.C. 24"	P.C.	Balanced Cantilever & Span/Span		1995	Limited Access Wetlands	47'-8"	\$ 32.8 M	\$ 32.8 M	753,132	\$43.55	Charleston South Carolina	SCDOT	Flag Engineering	T.L. James & Associates J.V.	T. DeLaven

AMERICAN SEGMENTAL BRIDGE INSTITUTE  
COST OF CONCRETE SEGMENTAL BRIDGES

TYPE OF BRIDGE	PROJECT NAME	SPAN RANGE	TYPE OF PILE	C.I.P. P.C. OTHER	SPAN/BALANCE OTHER	OVERLAY GRINDING GROOVING	YEAR BID	SPECIAL CONDITION	BRIDGE WIDTH	TOTAL COST OF PROJECT	TOTAL COST OF BRIDGE	SG. FT. OF BRIDGE	COST PER SQ. FT.	YWE ADJUST COST	LOCATION	OWNER	DESIGNER	CONTRACTOR
BRIDGE OVER WATER	Seabreeze Bridge	250'	24" P.C.	P.C.	Balanced Cantilever	Grinding & Grooving	1995	Value Engineering	50'	\$ 24.0 M	\$ 20.5 M	225,824	\$90.80	\$99.77	Daytona Beach Florida	FDOT	Parsons Brickerhoff / Finley McIlroy	GLF Construction Corporation
BRIDGE OVER WATER	Bath-Woolwich	200'-420'	8' Diameter Drilled Shaft	P.C.	Balanced Cantilever		1997		82'	\$ 46.6 M	\$ 42.1 M	221,647	\$190.00	\$194.04	Bath, Maine	Maine DOT	Ripp Engineering	Flabon
BRIDGE OVER WATER	Sailboat Bridge	122'	108" Drilled Shaft	P.C.	Span/Span		1998		2 @ 41'-4"	\$ 20.4 M	\$ 20.4 M	252,052	\$80.90	\$82.33	Delaware County Grand Lake, Oklahoma	OK DOT	Ripp Engineering	Traylor Bros.
BRIDGE OVER WATER	Pulham St.	182' to 322' 182'	72" Drill Shaft	C.I.P.	Balanced Cantilever	Microsilica W5	1998		70'	\$ 11.1 M	\$ 7.9 M	45,000	\$164.56	\$167.49	Marletts Ohio	Washington County	HNTB/Finley McIlroy	Kokosing
BRIDGE OVER WATER	Evans Cray St	180'	30" PC	P.C.	Span/Span	Class V Grinding & Grooving	1998	Slip Impact Shallow Water	49'-4"	\$30.75 M	\$ 25.65 M	294,380	\$87.84	\$89.20	Shuak Florida	FDOT	Belwenger, Hoch & Assoc. Finley McIlroy	PCL Civil Constructors
BRIDGE OVER WATER	Broadway	164' to 262'	48" & 60" Drill Shafts	P.C. Variable Depth	Balanced Cantilever	Class V Grinding & Grooving	1998	Fender System Collarless & Seal in Pile Architectural Features	46.4'	\$ 30.9 M	\$ 25.9 M	291,189	\$89.04	\$90.61	Daytona Beach Florida	FDOT	Ripp Engineering	Mueser Martz
BRIDGE OVER WATER	I-95 Bridge Over James River	387' 615' 354'	Drilled Shafts	C.I.P.	Balanced Cantilever	Microsilica	1998	Over River	57'	\$ 125.90 M	\$ 47.61 M	232,341	\$204.62	\$208.54	Richmond Virginia	VDOT	Parsons Brickerhoff	Conddle America, Inc.
BRIDGE OVER WATER	Creve Coeur Park Memorial	165' to 469'	H-Piles Spread Foot. Drilled Shafts	C.I.P.	Balanced Cantilever	Silica Fume Concrete Wearing Surface	1999		182'	\$ 73.5 M	\$ 73.5 M	460,105	\$159.66	\$159.66	St. Louis Missouri	Missouri Highway and Transportation Commission	Sverdrup Civil	Walker & SO
BRIDGE OVER WATER	Highway Bridge Replacement	178' to 330'	60" Cylinder Piles	P.C.	Balanced Cantilever	Grinding and Grooving	2000	Design-Build	800.5'	\$ 61.5 M	\$ 61.5 M	576,241	\$106.73	\$106.73	Pensacola City Florida	Florida DOT	HNTB	Grande Const.
BRIDGE OVER WATER	Memorial Causeway	166' to 360'	64" Drilled Shafts	C.I.P.	Balanced Cantilever	High Level Variable Depth Grinding and Grooving	2001	VECP	112' 7"	\$ 47.62 M	\$ 29.54 M	263,445	\$112.16	\$112.16	Clevesville Florida	Florida DOT	HDR and JWB/EARTHTECH	PCL
BRIDGE OVER WATER	Ringling Bridge Replacement	300'	66" Drilled Shafts	C.I.P. Pier Seg PC-Over Seg	Balanced Cantilever	Grinding and Grooving	2001		106'	\$ 76.0 M	\$ 56.0 M	326,255	\$170.60	\$170.60	Sarasota Florida	Florida DOT	JMI	PCL
BRIDGE OVER WATER	Royal Park Bridge	59' to 131'	Drilled Shafts	C.I.P.	Balanced Cantilever	Grinding and Grooving	2001	Bascule Main span Twin Bridges	42' 9" x 2	\$ 52.0 M	\$ 20.27 M	72,534	\$279.52	\$279.52	West Palm B. Florida	Florida DOT	E.C. Driver	Balfast Nedam

279.52

AMERICAN SEGMENTAL BRIDGE INSTITUTE  
COST OF CONCRETE SEGMENTAL BRIDGES

TYPE OF BRIDGE	PROJECT NAME	SPAN RANGE	TYPE OF PILE	C.I.P. P.C. OTHER	SPAN/BALANCE OTHER	OVERLAY GRINDING GROOVING	YEAR BID	SPECIAL CONDITION	BRIDGE WIDTH	TOTAL COST OF PROJECT	TOTAL COST OF BRIDGE	SQ. FT. OF BRIDGE	COST PER SQ. FT.	LOCATION	OWNER	DESIGNER	CONTRACTOR	SUBMITTED BY
VIADUCT	SR-50 DENNY CREEK BRIDGE	153.7 185-185 166-144 111.4	NONE	C.I.P.	Span/Span		1981		52'		\$11.4 M	187,351	\$60.80	SR50 Denny Creek	WSDOT	Dickerhoff & Widmann	Hensel Phelps Construction	M. Myer Levin
VIADUCT	Ramp "T" Over Fla. Turnpike	116'-224'	58" PC	P.C.	Balanced Cantilever	Grinding & Grooving	1982		42'-0"		\$4.97 M	91,271	\$54.44	Dade County Florida	FDOT	Behringer Hoch and Associates	Capella Bros.	L.M. Vargas
VIADUCT	I-750-505 Interchange Phase I	60' - 200'	58" PC	P.C.	Balanced Cantilever	Grinding & Grooving	1984		42'-0"	\$ 27.10 M	\$8.77 M	251,680	\$34.85	Fl. Lauderdale Florida	FDOT	Behringer Hoch and Associates	Cianbro Corporation	L.M. Vargas
VIADUCT	Palmetto	84' to 215'		P.C.	Balanced Cantilever		1984				\$7.83 M	197,700	\$39.60	Florida	FDOT			A. Monson
VIADUCT	Airport	85' to 162'		P.C.	Balanced Cantilever		1985				\$5.29 M	124,500	\$42.50	Florida	FL DOT			A. Monson
VIADUCT	US 441 / I-595	124' to 224'		P.C.	Balanced Cantilever		1986				\$11.94 M	177,199	\$67.10	Florida	FL DOT			A. Monson
VIADUCT	French Creek Viaduct	200/210'	60" drilled shafts	P.C.	Balanced Cantilever	Bituminous Paving	1987		33'-0"		\$2.78 M	44,220	\$63.03	Glenwood Canyon, CO.		HNTB	Flatron	M. Miller
VIADUCT	Bridge F-05-3H	200/210'	Steel H & Drilled Caissons	P.C.	Balanced Cantilever	Bituminous Paving	1987		33'-0"		\$7.12 M	113,700	\$62.63	Glenwood Canyon, CO.		HNTB	Flatron	M. Miller
VIADUCT	I-750-505 Interchange Phase II	60' - 200'	58" PC	P.C.	Balanced Cantilever	Grinding & Grooving	1988		42'-0"	\$ 51.1 M	\$ 27.85 M	536,943	\$51.16	Fl. Lauderdale Florida	FDOT	Behringer Hoch and Associates	Herbert Westbrook JV	L.M. Vargas
VIADUCT	C & D CANAL Bridge	150'	P.C. 24"	P.C.	Span/Span	Overlay and Grooving	1991		58'-4"	\$ 58.0 M	\$ 34.3 M	444,463	\$71.17	Middletown, Delaware	DelDOT	Figg Engineering	Rechi America Inc	Em Rosello
VIADUCT	Metro Greenline Bridge - Kramer & Rosecrans <small>copy file.aspx</small>	320'-185' segmental 125'	CIDH	C.I.P.	Balanced Cantilever	n/a	1991	Rail	27'	\$ 8.6 M	\$ 8.6 M	35,000	\$245.71	Los Angeles, CA	Los Angeles County MTA	T.Y. Lin International	Kiewit Pacific Co.	Paul Guntzel
VIADUCT	H3-North Haliwa	350' - 375'	CIDH	C.I.P.	Balanced Cantilever	Overlay	1991	Overhead Gantry	2 x 41' /As	\$ 149.4 M		479,000	\$311.50	Honolulu, HI	Hawaii DOT	T.Y. Lin International	Kiewit Pacific Co.	Paul Guntzel

**AMERICAN SEGMENTAL BRIDGE INSTITUTE**  
**COST OF CONCRETE SEGMENTAL BRIDGES**

TYPE OF BRIDGE	PROJECT NAME	SPAN RANGE	TYPE OF PILE	C.I.P. P.C. OTHER	SPAN/BALANCE OTHER	OVERLAY GRINDING GROOVING	YEAR BID	SPECIAL CONDITION	BRIDGE WIDTH	TOTAL COST OF PROJECT	TOTAL COST OF BRIDGE	SQ. FT. OF BRIDGE	COST PER SQ. FT.	LOCATION	OWNER	DESIGNER	CONTRACTOR	SUBMITTED BY
VIADUCT	LA River Bridge	450 Segmental 140' <small>conv. fill spans</small>	CIDH	C.I.P.	Balanced Cantilever	n/a	1993	Rail	27.5'	\$ 13.4 M		35,913	\$344.36	Los Angeles, CA	Los Angeles County, MTA	Engineering Management Consultants	Kiewit Pacific Co.	Paul Giuntri
VIADUCT	US 163 Viaduct	120' to 180'		P.C.	Span/Span & Balanced Cantilever	Overlay	1993		26' - 30' X 2	\$ 71.3 M	1,300,000	\$39.00	Austin, Tx	TxDOT	TxDOT	Eby-Fisher	D. VanLanduyt	
VIADUCT	GCRTA Canal Bridge	95' to 158'-130'-158' 95'	Concrete Filled Pipe Piles	P.C.	Balanced Cantilever	Rail Bridge N/A	1994	Erected over active RR	28'	\$ 6.4 M	\$ 6.4 M	68,000	\$465.00	Cleveland, Ohio	Greater Cleveland Regional Transit Authority	Parsons Brickerhoff	Kokosing Construction Co.	Finley McNary T. Steinsack
VIADUCT	WMATA Branch Avenue	58' to 150'	P.C. 14"	P.C.	Span/Span	n/a	1995	WMATA Narrow Curved	32'-5"	\$ 44.0 M	\$ 90.2 M	84,940	\$119.55	Washington D.C.	WMATA	Figg Engineering	Reed/Amesco, Inc.	En Roselio
VIADUCT	WMATA FSA	100' to 149'	NIC	P.C.	Span/Span	Rail Bridge n/a	1995	Superstructure Only	Varies 17' Average	\$ 48.0 M	\$ 9.2 M	90,000	\$92.00	Washington D.C.	WMATA	Finley McNary V&CPC Redesign	Lane Construction	Finley McNary W.S. McNary
VIADUCT	I-93/I-90 Interchange I-93 NB (IC93AA)	100' to 217'	Drill Shafts	P.C. w/Integral Piers	Balanced Cantilever	Lanes or Microsilica	1996		Varies 51'-0" Max.	\$ 307.0 M	\$ 50.0 M	300,000	\$166.67	Boston, MA	Mass DOT	LeBason, Armstrong	Sletary, Interbeton White & Perini	C. Finley
VIADUCT	SR 87 Arizona	230' to 400'		C.I.P.	Balanced Cantilever	Overlay	1996			\$ 7.0 M			\$145.00	Arizona	AZDOT	T. Y. Lin International	Edward Kremer	T. Y. Lin International
VIADUCT	I-95 / US 95 Interchange (Spaghetti Bow)	92' - 6" to 212' - 6"	Drilled Shaft	P.C.	Span/Span & Balanced Cantilever	Grooving	1997	High Seismic Region Erected over I-95 & US-95 Complex Geometry	26' - 7" & 36' - 5"	\$ 92.0 M	\$ 24.0 M Superstr. Only	253,270	\$94.76 Superstr. Only	Las Vegas, NV	Nevada DOT	Parsons Brickerhoff	Walker & SCI	Finley McNary T. Steinsack
VIADUCT	I-205 Bridge Portland Light Rail Airport Max. Extension	100' Approx. Span 180' 2 - 250' 180'	Single 96" Diameter Drilled Shafts		Balanced Cantilever	Rail Bridge n/a	1998	High Seismic Region Erected over I-205	24' - 3"			39,730 Total 29,425 Segmental		Portland, OR	Tri-Met	Finley McNary	Bachtel Infrastructure	Finley McNary T. Steinsack
VIADUCT	I-93 Viaducts and Ramps	90' to 204'	Drilled Shafts 7' - 8' - 9'	C.I.P.	Span/Span & Balanced Cantilever		1998		22' - 46'	\$ 79.3 M	\$ 20,000	5152.00	\$152.00	Boston, MA	Mass DOT	Figg Engineering	Modern Continental	Figg Engineering
VIADUCT	I-665 Main Line East - West Approach	102' to 141'	H Piles	P.C.	Balanced Cantilever	Microsilica	1998		57' +/-	\$ 125.9 M	\$ 42.82 M	374,047	\$114.47	Richmond Virginia	VDOT	Parsons Brickerhoff	Reed/Amesco, Inc.	C. Bellero
VIADUCT	I-665 Ramps E, G, H	135' +/-	H Piles	P.C.	Span/Span	Microsilica	1998		30' +/-	\$ 125.9 M	\$ 17.37 M	126,043	\$140.34	Richmond Virginia	VDOT	Parsons Brickerhoff	Reed/Amesco, Inc.	C. Bellero

AMERICAN SEGMENTAL BRIDGE INSTITUTE

COST OF CONCRETE SEGMENTAL BRIDGES

TYPE OF BRIDGE	PROJECT NAME	SPAN RANGE	TYPE OF PILE	C.I.P. P.C. OTHER	SPAN/BALANCE OTHER	OVERLAY GRINDING GROOVING	YEAR BID	SPECIAL CONDITION	BRIDGE WIDTH	TOTAL COST OF PROJECT	TOTAL COST OF BRIDGE	SQ. FT. OF BRIDGE	COST PER SQ. FT.	TIME ADJUST COST	LOCATION	OWNER	DESIGNER	CONTRACTOR
VIADUCT	I-250-40 Interchange Bg 1	150' -> 200'	Drilled Shafts	P.C.	Balance Cantilever	Grinding Grooving	2000		32'-0" & 42'-4"	\$ 222.0 M	\$ 25.80 M	321,290	\$82.79	\$82.79	Albuquerque New Mexico	NMSHTD	URS	Twin Mountain Kevitt
VIADUCT	Palm Beach International Airport SR9695 Interchange	115' to 238'	24" Pile	P.C.	Balance Cantilever	Grinding	2000	No Excuse Boxes 1000 days to Complete	Single Lane 40' Dual Lane 50'	\$ 110.0 M	\$ 50.0 M	900,979	\$69.80	\$69.80	West Palm Beach, Florida	FDOT	BHA	Modern Continental South
VIADUCT	Jacksonville South Interchange SR9A95/295	134' to 259' 134' to 219' 144' to 248'	24" Pile	P.C.	Balance Cantilever	Grinding and Grooving	2001	Ramp G-2 Ramp H-1 Ramp I-2	25' 0" 42' 0" 42' 0"	\$ 98.8 M \$ 12.7 M \$ 9.0 M	\$ 5.6 M \$ 12.7 M \$ 9.0 M	55,412 142,825 104,582	\$105.74 \$88.85 \$85.25	\$105.74 \$88.85 \$85.25	Jacksonville Florida	FDOT	Parsons Transporter Group	AMEC Civil
VIADUCT	Fl. Lauderdale Airport Interchange	120' to 220'	18" Pile	P.C.	Balance Cantilever	Grinding and Grooving	2000	Design-Build	55' Max	\$ 8.8 M	\$ 24 M	241,215	\$69.00	\$69.00	Fl. Lauderdale Florida	Broward County	BHA	PCL

VIADUCT	Viaduct/C09C1 I-93 / 80 Interchange		Steel 18" Dia and Drilled Shafts 8' - 9'	P.C.			1995	Demolition of Existing Struct. not included in cost of new bridge		\$ 108.0 M	\$ 27.84 M	136,400	\$199.71	\$214.12	Boston, MA	Massachusetts Highway Department		Modern Continental
VIADUCT	Viaduct/C012B1 North of Charles River		Steel and Cilled Shafts 8' - 9'	P.C.			1997			\$ 187.0 M	\$ 70.36 M	487,900	\$144.21	\$147.89	Boston, MA	Massachusetts Highway Department	DRC	Modern Continental
VIADUCT	Viaduct/C09A4 I-93 North Bound		Precast Piles and Drilled Shafts 6' - 7' - 9'	P.C.			1997			\$ 387.5 M	\$ 53.5 M	273,550	\$195.57	\$209.08	Boston, MA	Massachusetts Highway Department		Skelly Interbeton White Perini JV
VIADUCT	Viaduct/C092C4			P.C.			1997			\$ 17.6 M		43,250	\$405.93	\$406.20	Boston, MA	Massachusetts Highway Department		
VIADUCT	Viaduct/C092C2			P.C.			1997			\$ 45.7 M		130,800	\$346.39	\$374.59	Boston, MA	Massachusetts Highway Department		
VIADUCT	Leroy Selmon Bridge		Drill Shafts	P.C.	Span by Span		2002	Large wing Curved bottom and sides		\$ 158.8 M					Tampa Florida	Tampa Hillsborough Xway Authority	Figg Engineering	PCL Civil

AMERICAN SEGMENTAL BRIDGE INSTITUTE

COST OF CONCRETE SEGMENTAL BRIDGES

TYPE OF BRIDGE	PROJECT NAME	SPAN RANGE	TYPE OF PILE	C.I.P. P.C. OTHER	SPAN/BALANCE OTHER	OVERLAY GRINDING GROOVING	YEAR BID	SPECIAL CONDITION	BRIDGE WIDTH	TOTAL COST OF PROJECT	TOTAL COST OF BRIDGE	SQ. FT. OF BRIDGE	COST PER SQ. FT.	LOCATION	OWNER	DESIGNER	CONTRACTOR	SUBMITTED BY
CABLE STAYED	Talmage Bridge	470' 1100' 470'	Steel H	C.I.P.	Balanced Cantilever	Overlay and Grooving	1987		79'	\$ 7 M	\$ 34.0 M	161,160	\$211.00	Savannah Georgia	Ge DOT	DRC	Mottley-Groves J.V.	B. West
CABLE STAYED	C & D CANAL Bridge	750'	P.C. 24"	P.C.	Cantilever Construction	Overlay and Grooving	1991		58'-4"	\$ 50.0 M	\$ 17.7 M	35,497	\$155.35	Middletown, Delaware	DelDOT	Figg Engineering	Recchi America, Inc	Em/Rosello
CABLE STAYED	Poss Waterway	2 Approach 136/140' 375/132'	9" - 12" Drilled Shaft	C.I.P.	Falsework Supported	None	1994	Over Total water/urban area	Varies from 117.2' to 89.2'	\$ 17.9 M	\$16.8 M	102,531	\$164.50	Tacoma Washington	WaDOT		Max J. Kunev	J.A. Wigel
CABLE STAYED	Sidney Linker	625' 1250' 625'	72" Diam. Drill Shafts	C.I.P.	Balanced Cantilever	Grooving	1986	Two Rock Is.	79'-6"	\$ 65.4 M	\$ 55.6 M	198,750	\$269.95	Brunswick Georgia	Ge DOT	DRC	Recchi/GLF J.V.	B. West

## **Appendix B2: Listing of Certified Precasters in the USA**

An exhaustive listing of Precast/Prestressed Concrete Institute (PCI) certified precasters in the United States is available on-line at <http://www.pci.org/>. The certification categories are shown in the table below, followed by a listing of certified precasters in Region 5, which includes New Jersey, New York and Connecticut. This listing includes location, contact information, and areas of expertise of each company listed.

## PCI Certification Categories

### Group A - Architectural Products

AT - Architectural Trim Units  
A1 - Architectural Products

### Group B - Bridges

B1 - Precast Bridge Products  
B2 - Prestressed  
Miscellaneous Bridge Products

B3 - Prestressed Straight  
Strand Bridge Members

B4 - Prestressed Deflected  
Strand Bridge Members

### Group BA - Bridge Products with

an Architectural Finish

B1A, B2A, B3A, & B4A

### Group G - Glass Fiber Reinforced

Concrete (GFRC)

### Group C - Commercial (Structural)

C1 - Precast Concrete Products

C2 - Prestressed Hollowcore  
and Repetitive Products

C3 - Prestressed Straight  
Strand Structural Members

C4 - Prestressed Deflected  
Strand Structural Members

### Group CA - Commercial Products

with an Architectural Finish

C1A, C2A, C3A, & C4A

The following agencies either mandate or recommend PCI plant certification:

- Federal Aviation Administration, U.S. Department of Transportation
- Bureau of Reclamation, U.S. Department of the Interior
- Corps' Civil Works, U.S. Army
- Federal Highway Administration, U.S. Department of Transportation
- Federal Bureau of Prisons, U.S. Department of Justice
- U.S. Veteran Affairs
- U.S. Department of the Navy, Naval Facilities Engineering Command
- General Services Administration
- 30 State Departments of Transportation



## PCI Certified Precasters – Region 5

COMPANY	REGION	PHONE	PRODUCTS	CERTIFICATIONS
<b>Adaptive Concrete Solutions</b> Chantilly, VA	5	(703) 471-4162	Sound Walls, Piles, Box Beams/Voiced Slabs, Beams, Columns, Joists, Hollow Core Slabs	B3A,C2
<b>Architectural Cladding Systems, Inc.</b> Hollis, NH	5	(603) 889-6310	GFRC	G
<b>Architectural Precast LLC</b> Middleburg, PA	5	(570) 837-1774	Architectural Precast, Architectural Trim Units, Beams, Columns, Joists, Structural Wall Panels	A1,C2A
<b>Atlantic Metrocast, Inc.</b> Portsmouth, VA	5	(757) 397-2317	Piles, Box Beams/Voiced Slabs, I-Beams, Girders, Beams, Columns, Joists, Structural Wall Panels	B4,C3
<b>Atlantic Metrocast, Inc.</b> LaPlata, MD	5	(301) 870-3289	Piles, Box Beams/Voiced Slabs, Beams, Columns, Joists	B3,C1
<b>Bayside Concrete Products Corp.</b> Cape Charles, VA	5	(757) 331-2300	Sound Walls, Piles, Box Beams/Voiced Slabs, I-Beams, Girders, Beams, Columns, Joists, Structural Wall Panels, Poles, Segmental Bridge Units	B4,C4
<b>Bayside Concrete Products/Chesapeake, Inc.</b> Chesapeake, VA	5	(757) 549-1630	Piles, Box Beams/Voiced Slabs, I-Beams, Girders, Beams, Columns, Joists, Double Tees	B4,C2
<b>Blakeslee Prestress Inc.</b> Branford, CT	5	(203) 481-5306	Architectural Precast, Architectural Trim Units, Sound Walls, Piles, Box Beams/Voiced Slabs, I-Beams, Girders, Beams, Columns, Joists, Structural Wall Panels, Hollow Core Slabs, Single Tees, Double Tees, Stadium Seats, Cell Modules	A1,B4,C4A
<b>Capital Castings</b> General Porcelain Mfg. Co., Inc. Trenton, NJ	5	(609) 396-7588	GFRC	G
<b>Concrete Building Systems, Inc.</b> Delmar, DE	5	(302) 846-3645	Box Beams/Voiced Slabs, Beams, Columns, Joists, Structural Wall Panels, Single Tees, Double Tees, Stadium Seats	B3,C4
<b>Concrete Precast Systems, Inc.</b> Chesapeake, VA	5	(757) 545-5215	Architectural Precast, Architectural Trim Units, Sound Walls, Piles, Box Beams/Voiced Slabs, Beams, Columns, Joists, Structural Wall Panels, Double Tees, Stadium Seats	A1,B2,C3
<b>Conewago Precast Building Systems</b> Conewago Enterprises, Inc. Hanover, PA	5	(717) 632-7722	Architectural Precast, Structural Wall Panels, Hollow Core Slabs	C2
<b>Coreslab Structures (CONN) Inc.</b> Thomaston, CT	5	(860) 283-8281	Architectural Precast, Architectural Trim Units, Sound Walls, Box Beams/Voiced Slabs	A1
<b>David Kucera Inc.</b> Gardiner, NY	5	(845) 255-1044	Architectural Trim Units, GFRC	A1,G
<b>Fabcon East Corp., LLC</b> Mahanoy City, PA	5	(570) 773-2480	Structural Wall Panels, Hollow Core Slabs	C2
<b>Hanson Pipe &amp; Products, Inc.</b> Pottstown, PA	5	(610) 970-2216	Sound Walls, Box Beams/Voiced Slabs, Beams, Columns, Joists, Poles	B1A,C1A
<b>High Concrete Structures, Inc.</b> Denver, PA	5	(717) 336-9300	Architectural Precast, Architectural Trim Units, Beams, Columns, Joists, Structural Wall Panels, Single Tees, Double Tees, Stadium Seats, Cell Modules	A1,C3
<b>J. P. Carrara &amp; Sons, Inc.</b> Middlebury, VT	5	(802) 388-6363	Architectural Precast, Box Beams/Voiced Slabs, I-Beams, Girders, Beams, Columns, Joists, Structural Wall Panels, Hollow Core Slabs, Double Tees, Stadium Seats	A1,B4,C3A
<b>Jersey Precast Corp.</b> North Brunswick, NJ	5	(732) 249-8973	Box Beams/Voiced Slabs, I-Beams, Girders, Beams, Columns, Joists, Structural Wall Panels, Double Tees	B3,C3
<b>Knight Precast, Inc.</b> Glyndon, MD	5	(410) 833-7800	Box Beams/Voiced Slabs, Hollow Core Slabs	B3,C2
<b>Lakelands Concrete Products, Inc.</b> Lima, NY	5	(585) 624-1990	Architectural Precast, Architectural Trim Units, Sound Walls, Box Beams/Voiced Slabs, Beams, Columns, Joists, Structural Wall Panels, Double Tees, Cell Modules, Box Culverts	A1,B2,C3A
<b>Newcrete Products</b> Div. of New Enterprise Stone & Lime Co., Inc. Roaring Spring, PA	5	(814) 224-2121	Box Beams/Voiced Slabs, I-Beams, Girders, Beams, Columns, Joists, Structural Wall Panels, Single Tees, Double Tees, Stadium Seats, Cell Modules	B4,C4

## PCI Certified Precasters – Region 5 (cont'd)

<b>J. P. Carrara &amp; Sons, Inc.</b> Middlebury, VT	5	(802) 388-6363	<b>Architectural Precast, Box Beams/Voiced Slabs, I-Beams, Girders, Beams, Columns, Joists, Structural Wall Panels, Hollow Core Slabs, Double Tees, Stadium Seats</b>	A1,B4,C3A
<b>Jersey Precast Corp.</b> North Brunswick, NJ	5	(732) 249-8973	<b>Box Beams/Voiced Slabs, I-Beams, Girders, Beams, Columns, Joists, Structural Wall Panels, Double Tees</b>	B3,C3
<b>Knight Precast, Inc.</b> Glyndon, MD	5	(410) 833-7800	<b>Box Beams/Voiced Slabs, Hollow Core Slabs</b>	B3,C2
<b>Lakelands Concrete Products, Inc.</b> Lima, NY	5	(585) 624-1990	<b>Architectural Precast, Architectural Trim Units, Sound Walls, Box Beams/Voiced Slabs, Beams, Columns, Joists, Structural Wall Panels, Double Tees, Cell Modules, Box Culverts</b>	A1,B2,C3A
<b>Newcrete Products</b> Div. of New Enterprise Stone & Lime Co., Inc. Roaring Spring, PA	5	(814) 224-2121	<b>Box Beams/Voiced Slabs, I-Beams, Girders, Beams, Columns, Joists, Structural Wall Panels, Single Tees, Double Tees, Stadium Seats, Cell Modules</b>	B4,C4
<b>Newstress International, Inc.</b> Epsom, NH	5	(603) 736-9348	<b>Piles, Box Beams/Voiced Slabs, Beams, Columns, Joists, Structural Wall Panels, Hollow Core Slabs, Double Tees, Stadium Seats</b>	B3,C3
<b>Nitterhouse Concrete Products, Inc.</b> Chambersburg, PA	5	(717) 267-4505	<b>Architectural Precast, Beams, Columns, Joists, Structural Wall Panels, Hollow Core Slabs, Single Tees, Double Tees</b>	A1,C4A
<b>Northeast Concrete Products, LLC</b> Plainville, MA	5	(508) 695-1737	<b>Architectural Precast, Sound Walls, Piles, Box Beams/Voiced Slabs, I-Beams, Girders, Beams, Columns, Joists, Structural Wall Panels, Double Tees</b>	A1,B4,C4
<b>Oldcastle Precast Building Systems</b> Manchester, NY	5	(585) 289-3530	<b>Box Beams/Voiced Slabs, Beams, Columns, Joists, Structural Wall Panels, Hollow Core Slabs, Stadium Seats, Cell Modules</b>	B3,C3
<b>Oldcastle Precast Building Systems</b> South Bethlehem, NY	5	(518) 767-2269	<b>Box Beams/Voiced Slabs, Beams, Columns, Joists, Structural Wall Panels, Hollow Core Slabs, Single Tees, Double Tees, Cell Modules</b>	B3,C3
<b>Oldcastle Precast Building Systems</b> Morrisville, PA	5	(215) 736-9576	<b>Box Beams/Voiced Slabs, Beams, Columns, Joists, Structural Wall Panels, Hollow Core Slabs</b>	C3
<b>Oldcastle Precast Building Systems</b> Hatfield, PA	5	(215) 822-3341	<b>Box Beams/Voiced Slabs, I-Beams, Girders, Beams, Columns, Joists, Structural Wall Panels, Single Tees, Double Tees</b>	B4,C4
<b>Oldcastle Precast Building Systems</b> Edgewood, MD	5	(410) 612-1213	<b>Sound Walls, Box Beams/Voiced Slabs, Structural Wall Panels, Hollow Core Slabs</b>	C3A
<b>Oldcastle Precast, Inc./dba Chase Precast</b> North Brookfield, MA	5	(508) 867-8312	<b>Sound Walls, Box Beams/Voiced Slabs, Structural Wall Panels, Poles, Rail Road Ties, Cell Modules</b>	B2,C2A
<b>Oldcastle Precast, Inc./dba Rotondo Precast</b> Telford, PA	5	(215) 257-8081	<b>Box Beams/Voiced Slabs, Beams, Columns, Joists, Structural Wall Panels, Cell Modules, Box Culverts</b>	B1,C1
<b>Oldcastle Precast, Inc./dba Rotondo Precast</b> Fredericksburg, VA	5	(540) 898-6300	<b>Box Beams/Voiced Slabs, Beams, Columns, Joists, Structural Wall Panels, Cell Modules, Box Culverts</b>	B3,C1
<b>Oldcastle Precast, Inc./dba Rotondo Precast</b> Avon, CT	5	(860) 673-3291	<b>Box Beams/Voiced Slabs, Structural Wall Panels, Cell Modules, Box Culverts</b>	B1,C1A
<b>Oldcastle Precast, Inc./dba Rotondo Precast</b> Rehoboth, MA	5	(508) 336-7600	<b>Box Beams/Voiced Slabs, Beams, Columns, Joists, Structural Wall Panels, Hollow Core Slabs, Cell Modules, Box Culverts</b>	B3,C3
<b>Pittsburgh Flexicore Company, Inc.</b> Monongahela, PA	5	(724) 258-4450	<b>Hollow Core Slabs</b>	C2
<b>Precast Systems, Inc.</b> Allentown, NJ	5	(609) 208-1987	<b>Sound Walls, Piles, Box Beams/Voiced Slabs, I-Beams, Girders, Beams, Columns, Joists, Double Tees</b>	B4,C4
<b>Rockingham Precast, Inc.</b> Harrisonburg, VA	5	(540) 433-8282	<b>Box Beams/Voiced Slabs, I-Beams, Girders</b>	B4
<b>Rocla Concrete Tie, Inc.</b> Bear, DE	5	(302) 836-5304	<b>Rail Road Ties</b>	C2

## PCI Certified Precasters – Region 5 (cont'd)

<b>Say-Core, Inc.</b> Portage, PA	5	(814) 736-8018	<b>Hollow Core Slabs</b>	C2
<b>Schuylkill Products, Inc.</b> Cressona, PA	5	(570) 385-2352	<b>Sound Walls, Box Beams/Voiced Slabs, I-Beams, Girders, Beams, Columns, Joists, Structural Wall Panels, Cell Modules</b>	B4,C3
<b>Sidley Precast</b> Division of R.W. Sidley, Inc. Youngwood, PA	5	(724) 755-0205	<b>Beams, Columns, Joists, Structural Wall Panels, Hollow Core Slabs, Double Tees, Stadium Seats</b>	C3
<b>Smith-Midland Corporation</b> Midland, VA	5	(540) 439-3266	<b>Architectural Precast, Architectural Trim Units, Sound Walls, Box Beams/Voiced Slabs, Beams, Columns, Joists, Structural Wall Panels, Cell Modules</b>	A1,B1,C3
<b>Structural Concrete Products, LLC</b> Richmond, VA	5	(804) 222-8111	<b>Box Beams/Voiced Slabs, Beams, Columns, Joists, Structural Wall Panels, Double Tees, Stadium Seats</b>	B3,C4
<b>Symmetry Products Group / SPG</b> Div. of Lance Industries International, Inc. Lincoln, RI	5	(401) 365-6272	<b>GFRC</b>	G
<b>The Shockey Precast Group</b> Winchester, VA	5	(540) 667-7700	<b>Architectural Precast, Box Beams/Voiced Slabs, I-Beams, Girders, Beams, Columns, Joists, Structural Wall Panels, Rail Road Ties, Single Tees, Double Tees, Stadium Seats, Cell Modules</b>	A1,C4
<b>The Shockey Precast Group</b> Fredericksburg, VA	5	(540) 898-1221	<b>Architectural Precast, Architectural Trim Units, Beams, Columns, Joists, Structural Wall Panels</b>	A1,C2A
<b>The United Precasting Corporation</b> Buena, NJ	5	(856) 697-3600	<b>Box Beams/Voiced Slabs, Beams, Columns, Joists, Structural Wall Panels, Hollow Core Slabs, Double Tees</b>	C3
<b>Tindall Corporation</b> Virginia Division Petersburg, VA	5	(804) 861-8447	<b>Beams, Columns, Joists, Structural Wall Panels, Double Tees, Cell Modules</b>	C4A
<b>Top Roc Newcrete Products Company</b> A Div. of New Enterprise Stone & Lime Co., Inc. Erie, PA	5	(814) 838-2011	<b>Box Beams/Voiced Slabs, I-Beams, Girders, Beams, Columns, Joists, Cell Modules</b>	B4,C1
<b>Unistress Corporation</b> Pittsfield, MA	5	(413) 499-1441	<b>Architectural Precast, Sound Walls, Piles, Box Beams/Voiced Slabs, I-Beams, Girders, Beams, Columns, Joists, Structural Wall Panels, Single Tees, Double Tees, Stadium Seats, Segmental Bridge Units</b>	A1,B4,C4A
<b>Universal Concrete Products Corporation</b> Bodon Industries Douglassville, PA	5	(610) 323-0700	<b>Architectural Precast, Architectural Trim Units, Beams, Columns, Joists, Structural Wall Panels, Stadium Seats</b>	A1,C2
<b>Universal Concrete Products of NJ, Inc.</b> Folsom, NJ	5	(609) 704-9400	<b>Architectural Precast, Architectural Trim Units, Beams, Columns, Joists, Structural Wall Panels</b>	A1,C2
<b>Vynorious Prestress, Inc.</b> Salisbury, MA	5	(978) 462-7765	<b>Piles</b>	C2
<b>William E. Dailey, Inc.</b> Shaftsbury, VT	5	(802) 442-4418	<b>Architectural Precast, Sound Walls, Box Beams/Voiced Slabs, Beams, Columns, Joists, Structural Wall Panels, Double Tees</b>	A1,B2,C3

## Appendix B3: Innovative Projects – Location and Description

Details of the innovative projects may be viewed and copied from the electronic version of this report. This may be done by clicking on the captioned photographs and zooming in on the picture.

### Dead Run and Turkey Run Bridges

**Prefabricated Elements:** Decks (Full-depth non-composite decks)

**Location:** George Washington Memorial Parkway

**State:** VA

**Completion Date:** 1998

**Contacts :** Phone: (703) 404-6233 Fax: (703) 404-6234

Email: [hala.elgaaly@fhwa.dot.gov](mailto:hala.elgaaly@fhwa.dot.gov)

**Description:** The George Washington Memorial Parkway experiences heavy commuter usage from workers traveling from Virginia and Maryland into Washington D.C. The 1996 average daily traffic for the Parkway was 42,800 vehicles, with 53,500 vehicles/day projected for 2016. Because of its heavy commuter use, the bridges over Dead Run and Turkey Run needed to be kept open to traffic on weekdays during replacement of bridge decks. The Dead Run Bridge consists of two structures that each carries two lanes of traffic; the bridge is 305 feet long with a 3-span configuration. The Turkey Run bridge is also two structures that each carry two lanes of traffic, and it has a length of 402 feet in a 4-span configuration. Both bridges have an 8-inch concrete deck supported on steel beams with non-composite action. The non-composite aspect of the original design, along with the use of precast concrete post-tensioned full-depth deck panels, facilitated quick deck replacement and allowed the structures to be kept open during weekday traffic. The construction sequence closed the bridge on Friday evening, saw cut the existing deck into transverse sections that included curb and rail, removed the saw cut sections of the deck, set new precast panels, stressed the longitudinal tendons after all panels in a span were erected, grouted the area beneath the panel and above the steel beam, and opened the bridge to traffic by Monday morning. The construction rate was replacement of one span for one bridge per weekend.



**Advantages:** Minimized traffic disruption. Traffic was maintained during weekdays to minimize effect on commuters from Virginia and Maryland into Washington D.C.

## **Tappan Zee Bridge**

***Prefabricated Elements:*** Decks ( Exothermic deck panels)

***Location:*** Hudson River, about 13 miles north of New York City

***State:*** NY

***Contact:*** Phone: (518) 436-2700 (Interchange 23)

***Description:*** The 16,000-foot Tappan Zee Bridge carries approximately 130,000 vehicles per day over the Hudson River on the New York State Thruway system. Because it is a critical route for commuters, the New York State Thruway Authority requires that work projects keep all lanes of traffic open for morning and evening rush hour traffic. In 1998, a necessary redecking project for the east deck truss spans began replacement of more than 250,000 square feet of deck in nighttime work, opening all seven lanes to traffic by 6 AM. The project used proprietary full-depth deck panels, 7 ½ in. thick overall. 1200 exodermic panels were required, typically 24 ft. x 12 ft. or 18 ft. x 12 ft. and weighing 18,000-13,000 lbs.



***Advantages:*** Minimized traffic disruption: Exodermic deck panels allowed rapid placement of the panels, which provide the durability of reinforced concrete but weigh 35-50% less.

## **I-5/South 38th Street Interchange**

***Prefabricated Elements:*** Decks (Precast stay-in-place deck panels; precast post-tensioned tub girders )

***Location:*** Tacoma

***State:*** WA

***Completion Date:*** 2001

***Contacts:*** Phone: (360) 705-7166 . Email: [merthjo@wsdot.wa.gov](mailto:merthjo@wsdot.wa.gov)

***Description:*** To reduce construction time and minimize traffic disruption, the Washington State Department of Transportation chose precast stay-in-place deck panels in the design of this two-span, 325-foot replacement bridge over I-5 in Tacoma. The new post-tensioned box girder bridge uses precast tub girder segments. With no need to construct and remove conventional deck forms, lane closures on I-5 were greatly reduced. Leveling screws were used to adjust camber on the 3-1/2-inch-thick precast pretension panels, and all 766 panels were placed within a week of limited nighttime I-5 lane closures.

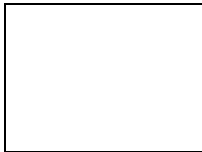

***Advantages:*** Minimized traffic disruption by reducing construction time.

## **I-45/Pierce Elevated**

***Prefabricated Elements:*** Bent caps; decks (Precast bent caps; precast prestressed deck panels; precast prestressed I-beams )

***Location:*** Downtown Houston

***State:*** TX

***Completion Date:*** 1997

***Contacts:*** Phone: (713) 802-5435. Email: [kozuna@dot.state.tx.us](mailto:kozuna@dot.state.tx.us)

***Description:*** When a 113-span section of IH 45 in Houston's central business district needed replacing, designers estimated that a conventional bridge system would require more than a year and a half of construction. Estimating user delay costs at \$100,000 a day, TxDOT opted to speed construction by using precast bent caps on the existing columns. The bridge consists of twin structures, one northbound and one southbound, and each structure was completed in 95 days, a total of 226 spans replaced in 190 days. To connect the precast caps to the existing columns, the precast caps were anchored with post-tensioning bars and hardware.

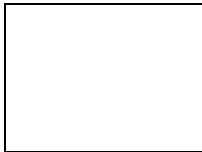

***Advantages:*** Minimized traffic disruption: construction time was reduced from an estimated 1.5 years to 190 days, with user delay costs estimated at \$100,000/day.

## **Illinois Route 29 over Sugar Creek**

***Prefabricated Elements:*** decks (Full depth, full width, precast post-tensioned concrete deck panels, precast concrete New Jersey parapets)

***Location:*** 1 mile east of Springfield, in Sangamon County

***State:*** IL

***Completion Date:*** 2001

***Contacts:*** Phone: (217) 785-2913 Email: [domagalskitj@nt.dot.state.il.us](mailto:domagalskitj@nt.dot.state.il.us)

***Description:*** This project required redecking an existing five-span bridge 77.13 meters long. The bridge consisted of a simple-span unit at 12.48 meters, a two-span continuous unit with both at 18.25 meter, and another two-span continuous unit at 12.95 and 12.88 meters. The existing steel beams were reused and made composite with the precast deck panels. The bridge was 11.4 meters wide. The concrete deck panels ( $f'c = 35$  MPa) were 195 millimeters in depth, 11.3 meters in width, and typically 2.5 meters in length. A total of 29 panels were laid across the length of the bridge. Panels used shear keys between the panels and were post-tensioned longitudinally with 25.4-millimeter-diameter high-strength steel bars at 462-millimeter centers.

***Advantages:*** Minimized traffic delays by speeding up the construction time.



## **Keaiwa Stream Bridge**

***Prefabricated Elements:*** decks (4-foot-wide by 11-inch-thick precast prestressed concrete deck planks)

***Location:*** Route 11 near Pahala

***State:*** HI

***Completion Date:*** 2000

***Contacts:*** Phone: (808) 692-7611, Email: [paul\\_santo@exec.state.hi.us](mailto:paul_santo@exec.state.hi.us)

***Description:*** A record rainstorm in late 2000 caused major damage to the only route on the southeast side of the Big Island of Hawaii. The State of Hawaii Department of Transportation chose to replace the 80-foot Route 11 bridge near Pahala with a longer structure to prevent future damage from flooding. The new 7-span, 230-foot concrete bridge, using precast prestressed concrete planks with cast-in-place concrete topping, was in operation within seven months.

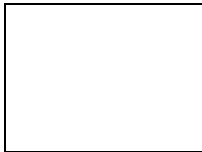

***Advantages:*** Minimized traffic disruption by reducing construction time and limiting lane closures.; Minimized environmental disruption because deck topping did not require shoring or falsework in the streambed, and minimized traffic disruption because precast planks were fabricated during pier construction.

## **Lavaca Bay Causeway**

***Prefabricated Elements:*** decks (Girder/slab/diaphragm/center median/curb/sidewalk/parapet walls precast and later prestressed as a single unit, precast monolithic beams)

***Location:*** Between Port Lavaca and Point Comfort, over the Lavaca Bay

***State:*** TX

***Completion Date:*** 1961

***Contacts:*** Phone: (361) 293-4300, Email: [mbayles@dot.state.tx.us](mailto:mbayles@dot.state.tx.us)

***Description:*** Completed in 1961, the bridge that carries SH 35 across Lavaca Bay is the longest bridge in Texas, spanning 11,900 feet. The bridge contains two 26-foot roadway slabs and a raised 6-foot median, making the four-lane highway a total of 63 feet wide. Precasting occurred on the shore near the construction site. Precast girder, slab, diaphragm, center median, curb, sidewalk, and parapet wall units were precast on shore, barged into position between bents, and then lowered into place hydraulically. Each roadway slab weighed 150 tons.



***Advantages:*** Constructability

## **Route 7 over Route 50**

***Prefabricated Elements:*** decks ( Precast deck panels (lightweight))

***Location:*** Fairfax County

***State:*** VA

***Completion Date:*** 1999

***Contacts:*** Phone: (703) 383-2117 Email: [Nicholas.Roper@VirginiaDOT.org](mailto:Nicholas.Roper@VirginiaDOT.org)

***Description:*** Replacement of the Route 7 over Route 50 bridges in Fairfax County required VirginiaDOT to replace approximately 14,000 square feet of deteriorating bridge deck. VirginiaDOT opted to use precast deck panels to satisfy community concerns about reductions in the level of service. Operating only at night, crews saw cut sections of the existing deck, lifted and removed them by crane, and immediately installed new deck panels that matched the deck cavity. They then placed a rapid-setting concrete overlay that supported full traffic after only three hours of curing. The bridge was completely open to traffic during the day.



***Advantages:*** Minimized traffic disruption by reducing construction time and minimized equipment needed and dead load on the existing structure.

## **Route 57 over Wolf River**

***Prefabricated Elements:*** bent caps; decks, Precast bent caps; precast prestressed concrete stay-in-place deck forms; precast prestressed I beams; steel pipe piles

***Location:*** Fayette County

***State:*** TN

***Completion Date:*** 1999

***Contacts:*** Phone: (615) 741-3351, Email: [Ed.Wasserman@state.tn.us](mailto:Ed.Wasserman@state.tn.us)

***Description:*** The Wolf River Bridge in Fayette County, Tennessee, crosses sensitive wetlands and carries the only east-west route through its geographic region. For the 20-span replacement bridge, the Tennessee Department of Transportation chose staged construction, maintaining one lane of traffic with timed signals. TDOT designers selected precast prestressed beams to facilitate speedy construction and allowed optional stay-in-place precast prestressed concrete deck forms. TDOT and the contractor developed details for precasting bent caps in two pieces to suit staged construction. Construction of the 1,408-foot long, 46-foot wide bridge was completed in eleven months without putting any equipment in the surrounding wetlands.



***Advantages:*** Minimized environmental disruption by eliminating the need to place equipment in surrounding wetlands, and minimized traffic disruption of an important east-west corridor.

## **SH 36 over Lake Belton**

***Prefabricated Elements:*** bent caps; decks (Precast bent caps; precast prestressed deck panels; precast prestressed U-beams)

***Location:*** Near Waco

***State:*** TX

***Completion Date:*** 2004

***Contacts:*** Phone: (512) 416-2279, Email: [lwolf@dot.state.tx.us](mailto:lwolf@dot.state.tx.us)

***Description:*** Because of fluctuating water surface elevations on the lake and uncertainties about performance of underwater precast column joints, designers chose a cast-in-place twin-column arrangement for replacement of the Lake Belton bridge. Twin bridges will be 3,840 feet long with 62 identical precast interior bent caps. The hammerhead bents will be some of the highest-moment-demand cap-to-column connections used yet with precast caps in Texas, presenting new design challenges. TxDOT bridge designers are developing design procedures extended for high-moment-demand connections. TxDOT has funded a 2002 Research Implementation Project to adapt and implement guidelines for multi-column bent cap connections to single-column, high-moment-demand connections and to continue development of specifications addressing grout placement, segregation, and durability.



***Advantages:*** Constructability: A primary source of water for Waco and an important flood control resource for the area, Lake Belton's water level is highly variable, as much as 48 ft, reaching as high as the bottom of the bridge's beams on occasion. Using precast components limits construction dependence on the lake level.

## **SH 66/ Lake Ray Hubbard**

***Prefabricated Elements:*** bent caps; decks (Precast bent caps; precast prestressed deck panels; precast prestressed I-beams)

***Location:*** Near Dallas

***State:*** TX

***Completion Date:*** 2002

***Contacts:*** Phone: (512) 416-2279, Email: [lwolf@dot.state.tx.us](mailto:lwolf@dot.state.tx.us)

***Description:*** After 40 years of service, the narrow two-lane crossing of SH 66 over Lake Ray Hubbard had become a congested route for commuters in the suburbs east of Dallas and needed to be replaced. In 2000, construction began on a pair of conventional prestressed concrete I beam bridges with lengths of 10,280 and 4,360 feet. After the project was let for construction, the contractor asked to precast the substructure bent caps as an alternative to the original design of cast-in-place multi-column bents to reduce the amount of time the workers would need to operate near power lines. TxDOT designed a precast bent cap option that included a cap-to-column connection and a specific construction procedure that allowed early placement of caps and prestressed beams based on achieved cap concrete and cap grout connection strength. The connection design included reinforcing steel dowel bars that protrude from the columns into the precast caps via open plastic ducts that are grouted after cap placement. On this project a total of 43 bent caps will be precast.

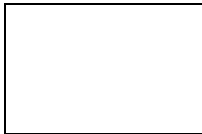

***Advantages:*** Work zone safety: reduced amount of time required for work near power lines and reduced work time over water (80% of work on caps was done on the ground). Minimized traffic disruption: Using precast caps produced a saving of 5-7 days per cap, distributed across activities associated with formwork, curing, steel, inspection, and bearing seats.

## **SH 249/Louetta Road Overpass**

***Prefabricated Elements:*** total substructure systems; decks (Precast pretensioned partial-depth deck panels, precast post-tensioned piers, pretensioned U-beams)

***Location:*** Houston

***State:*** TX

***Completion Date:*** 1994

***Contacts:*** Phone: (512) 416-2183, Email: [mralls@dot.state.tx.us](mailto:mralls@dot.state.tx.us)

***Description:*** In the early 1990's Texas State Highway 249 was upgraded from a four-lane, at-grade road to a limited-access freeway. Consequently, two overpass structures were built at Louetta Road to carry three lanes in each direction, plus shoulders and ramp transitions. The superstructure consists of simple-span pretensioned trapezoidal-shaped 54-inch U-beams as well as precast pretensioned deck panels supported on the U-beams' top flanges with a cast-in-place composite concrete topping. The bridges are three spans each, nominally 130 ft. per span. At the interior bents, each beam is supported by a single post-tensioned pier. All beams and piers were designed and fabricated using high-performance/high-strength concrete.



***Advantages:*** Minimized traffic disruption

## **Spur Overpass over AT&SF Railroad**

***Prefabricated Elements:*** decks (precast full-depth deck panels)

***Location:*** Downtown Lubbock

***State:*** TX

***Completion Date:*** 1988

***Contacts:*** Phone: (806) 745-4411, Email: [cutley@dot.state.tx.us](mailto:cutley@dot.state.tx.us)

***Description:*** Built in 1958, the SPUR (loop) 326 bridge at AT&SF Railway has a total length of 545 ft. and consists of two separate non-composite structures handling traffic travelling in the north-south directions. In 1986, the bridge underwent rehabilitation because of signs of early deck deterioration and a need to widen the roadway width to accommodate increasing traffic. The new deck is made of eight precast full-depth panels, each 6ft. 3 in. x 45 ft. x 8 in. and epoxied into place. The construction time was only a couple of days, a significantly shorter time than if the deck had been cast in place.



***Advantages:*** Minimized traffic disruption



## **Troy-Menands Bridge**

***Prefabricated Elements:*** decks ( Exodermic deck panels)

***Location:*** Between the City of Troy and the Village of Menands in Rensselaer and Albany Counties

***State:*** NY

***Completion Date:*** 1995

***Contacts:*** Phone: (518) 473-0497, Email: [TConway@gw.dot.state.ny.us](mailto:TConway@gw.dot.state.ny.us)

***Description:*** The Troy-Menands Bridge carries Route 378 over the Hudson river in Rensselaer and Albany Counties. The structure supplies access to local businesses in both counties as well as area colleges, and more than 36,000 vehicles cross it daily. Work of any kind on this structure is usually confined to off-peak hours for one-lane closures night-only hours for multiple-lane or total closures. When the badly deteriorating bridge deck needed to be replaced, the project was challenged to avoid impacting the travelling public to a significant degree. An around-the-clock detour was not feasible because of potential congestion for alternate crossings, especially during peak hour flows. New York State Department of Transportation's Region One Office opted to use precast deck panels, offering two precast options, and to require the contractor to complete the work during the hours of 10 pm to 6 am, closing only three of the four lanes. The contractor chose exodermic precast concrete deck panels using lightweight concrete, which increased the load-carrying capacity of the floor beams of the structure and made the panels more manageable and maneuverable during construction. The contractor was required to remove a portion of the deck, prepare it for the precast panel, install the new panel, and fill the joints with joint material. After a short learning period, the contractor was able to install six panels--just over 900 square feet of deck area--per night. Traffic was never delayed during the morning rush hour, and the contractor was never fined for late openings. Today the deck is still in very good shape some seven years after completion.

***Advantages:*** Minimized traffic disruption: Work occurred at night when traffic volume was low, with lanes open to full traffic by morning commuting hours.

## **US 27 over Pitman Creek**

***Prefabricated Elements:*** decks(Full-depth deck panels, New Jersey barrier railing )

***Location:*** Somerset

***State:*** KY

***Completion Date:*** 1993

***Contacts:*** Phone: (502) 564-4560, Email: [Steve.Goodpaster@mail.state.ky.us](mailto:Steve.Goodpaster@mail.state.ky.us)

***Description:*** The 700-foot bridge carrying US 27 over Pitman Creek in southern Kentucky is heavily used by vehicle and truck traffic and provides a major north-south road for the area. When the bridge deck needed to be replaced, the Kentucky Transportation Cabinet opted to do the work at night, keeping two lanes open during the day and one lane open at night. Using proprietary full-depth deck panels allowed modular construction, greatly minimizing traffic impacts as well as providing some weight savings by lightening the dead load on the truss. Project work was performed at night, with traffic routed to one lane at 6:00 pm and opened back to two lanes at 6:00 am. The slab between floor beams (25 feet) was removed and replaced with the full-depth deck panels. Using high-early-strength concrete allowed the joints between deck panels to be poured and opened to traffic next morning.

***Advantages:*** Minimized traffic disruption.

## **US 59 under Dunlavy, Hazard, Mandel and Woodhead Streets**

***Prefabricated Elements:*** decks (Precast prestressed deck panels)

***Location:*** Houston

***State:*** TX

***Completion Date:*** 1995

***Contacts:*** Phone: (713) 802-5235, Email: [jvogell@dot.state.tx.us](mailto:jvogell@dot.state.tx.us)

***Description:*** In the mid-1990's, widening of US 59 from six to ten lanes, including two high-occupancy-vehicle lanes, required replacement of bridges connecting streets in four Houston neighborhoods. Project challenges included neighborhood displeasure with proposed disruptions during on-site construction and restrictive clearances beneath the bridges. To maintain freeway traffic under the bridges and allow city street traffic over US 59 while removing and replacing the bridges, TxDOT provided attractive tied arch bridges, structures that suspend a thin slab from two tied arches 45 feet apart. The existing bridges were used as work platforms for erecting the arches, and the slabs were precast in segments and then bolted to erection beams to eliminate the need for falsework under the bridge during construction.



***Advantages:*** Minimized traffic disruption and improved constructibility: Restrictive clearances beneath the bridges made construction of falsework difficult without closing US 59.

## **Wesley Street Bridge**

***Prefabricated Elements:*** decks (Precast prestressed slab beams )

***Location:*** Ragsdale Creek in Jacksonville

***State:*** TX

***Completion Date:*** 2002

***Contacts:*** Phone: (903) 586-9878, Email: [shall3@dot.state.tx.us](mailto:shall3@dot.state.tx.us)

***Description:*** One of only two routes into or out of a populated housing community, Wesley Street crosses Ragsdale Creek in Jacksonville, Texas. When the bridge required replacement, TxDOT opted for accelerated construction to facilitate opening the bridge to traffic. Work on the project began in October 2001 and was completed in January 2002.

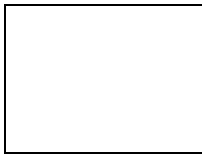

***Advantages:*** Minimized traffic disruption, reducing inconvenience to local commuters

# PART C: SMART BRIDGES

## INTRODUCTION

The deterioration of the U.S. infrastructure has reached alarming levels due to the large number of structures that are classified as functionally obsolete or structurally deficient. The large costs required for rehabilitation and replacement have led to the development and the application of methods to prioritize the rehabilitation/replacement process while ensuring the safety of the public. These methods, that use asset management principles, depend on accurate assessments of the conditions of the systems under consideration and true estimates of their useful lives. To obtain a good understanding of the behavior of structures under actual conditions, monitoring the behavior of large structures such as bridges, tunnels, and dams has become increasingly critical. A “smart bridge” can be defined as a bridge that has the ability to monitor its structural behavior and other performance during construction as well as under service loads and maximum loading conditions. Smart bridges usually utilize different instruments to monitor various physical parameters under different weather and loading conditions. Listed below are four of the most important parameters with which engineers are mostly concerned. They are:

- Displacement / Strain
- Stress / Pressure
- Cracking
- Corrosion / Temperature

Monitoring bridge displacements is a main concern because excessive displacements create public anxiety even though they may not be indicative of hazardous conditions. Stresses are the main criteria for structural safety and when they exceed permissible levels, damage as well as local failure or structural collapse may ensue. The presence of cracks should also be carefully monitored particularly when they have the tendency to grow. Corrosion leads to large reduction in a member’s load carrying capacity due to the loss in section and the cracking and spalling that they may induce. Large temperature variations also lead to changes in structural behavior. These variations affect material properties and may lead to high levels of stresses and the development of cracks.

In addition to their ability to monitor the behavior of the structure, smart bridges can be instrumented to monitor the loads to which they are exposed. Loads are very important variables that are impossible to predict during the design process. Although bridge design specifications provide generic live load and other load models that are used for design, these specified loads do not reflect the actual loading conditions for the particular bridge site under investigation. Weigh-In-Motion technology has been developed over the last two decades to provide information on the heavy traffic-induced live loads to which a bridge is exposed. Such information when combined with the data

collected on the response of the bridge to these applied loads, provides invaluable input for assessing the safety of bridges and predicting their useful lives.

The use of a permanent monitoring system on a smart bridge has several advantages compared to the traditional approach of visual inspection, combined with occasional on-site testing with portable equipment and laboratory testing of collected samples. In fact, the traditional inspection approach has some clear drawbacks that include:

- Traffic interference during inspection and on-site testing
- High cost of inspection, especially if providing access to hard to reach structural elements is necessary
- Scattered data, which makes prediction of the time to initiation of deterioration and future damage growth less accurate. In addition, large scatter in damage estimation may be found in readings by different inspectors.
- Infrequent inspection and testing, which may allow the deterioration to progress between inspections to an extent that makes efficient and cheap preventive M&R (maintenance and rehabilitation) strategies impossible.

The use of permanent monitoring has the following advantages once the system is installed:

- Traffic interference is reduced
- The cost of access to the structure and resources for inspection and testing are reduced
- Structural elements with difficult access are easily monitored
- Frequent collection of data enables more reliable trends for the development of deterioration and performance models

Data collected periodically from instrumented bridges is used to analyze and check bridge integrity giving early warnings that are helpful in preventing continuous damage growth. Bridge maintenance becomes easier and more economical when permanent monitoring can give an early indication of structural malfunction, so safety measures can be considered in time, and intervention on the structure can be performed immediately and with minimal economic losses. In addition, information gathered under actual conditions provides better resources to researchers and professionals to study and evaluate the structure. Design concepts can also be improved due to contribution from empirical in-situ results.

Although smart bridge concepts are normally applied on new bridge constructions, they can also be implemented on existing bridges, particularly for bridges under repair, refurbishment and reinforcement. These latter bridges usually require long term monitoring to ensure their safety after alterations to the original designs that may cause changes to their service lives.

This part reviews current technology for monitoring bridge behavior and existing weigh-in-motion (WIM) technology. The following sections present:

- background and issues related to bridge inspection and safety evaluation;
- a review of current practice and emerging issues in bridge condition monitoring;
- a description of current techniques in corrosion monitoring;
- a list of current methods for monitoring strains and cracks;
- a description of methods for deflection measurements; a state-of-the-art report on WIM technology; and
- a description of how the information collected on bridge member strengths and bridge loads can be implemented during the bridge rating process.

## **Background**

The AASHTO LRFD Bridge Design Specification defines service life as the period of time that a bridge is expected to be in operation. The design life is defined as the period of time on which the statistical derivation of transient loads is based. Though the subject specifications prescribe transient loads based on a design life of 75 years, it is implied that the 75-year period is equal to the expected service life.

Degradation caused by effects such as cracking, corrosion, etc., can compromise a bridge's ability to fulfill its intended function. High transient loads and severe environmental conditions are the major causes of degradation. The effects of high transient loads can be addressed through adequate member proportioning and design details.

Environmental effects on concrete bridge members include carbonation, sulfate attack, alkali-silica reaction, freeze-thaw cycles, and ingress of chlorides and other harmful chemicals. Chemicals invade the pore system of concrete and initiate chemical and/or physical reactions, typically resulting in the formation of expansive by-products. The expansive forces often produce cracking of concrete. The most damaging consequence of these reactions is the depassivation of steel, which results in corrosion. Corrosion of steel produces cracking, typically along the length of the steel and eventually leads to spalling of concrete. The end of the service life of the bridge occurs when the accumulated damage in the bridge materials exceeds the tolerance limit. The service life of the bridge can, however, be extended by performing periodic repairs. The need and extent of repair to a structure are established by performing periodic condition assessment reviews of the structure.

Condition assessment of bridge structures usually involves monitoring bridge structural elements, primarily the deck and girders, for (a) corrosion and (b) cracking associated with loading and/or corrosion. Cracking in the structural element, girder or deck, is produced when the stress in concrete exceeds its tensile strength. The cause of the stress could be external, i.e., due to applied loads, or internal, i.e., due to internal mechanisms such as corrosion, which produce an expansive force inside the concrete. Cracking in concrete often tends to accelerate corrosion, by allowing ingress of chlorides to the steel. Hence, often determining the cause and effect in the case of

cracking and corrosion is difficult. There is considerable interaction between the two, wherein corrosion produces cracking and cracking in the structure results in corrosion.

The influence of corrosion and cracking on the structural response primarily comprises the following:

- (1) Increase in deflections due to a decrease in the structural stiffness of the member. Often the degradation of the material is associated with a decrease in the structural stiffness, which results in increased deflection. These increased deflections in turn manifest themselves in the form of widening of the cracks.
- (2) Change in the reactions of the structure. The changes in the stiffness of the member lead to a redistribution of loads in the structure and hence a change in the reactions at the bearings.

## **BRIDGE CONDITION MONITORING – CURRENT PRACTICE AND EMERGING ISSUES**

Currently, NCHRP Report 312 provides a comprehensive summary for estimating the state of a concrete bridge superstructure element. In addition, several state DOTs have established their own practices for condition assessment of bridge decks. Qualitative measures of corrosion are obtained during the mandatory biennial bridge inspection. Inspection reports give ratings of bridge members based on the level of deterioration. Different rating scales have been developed by different agencies and groups such as FHWA, State DOTs and research agencies working on bridge management systems such as PONTIS. As per the FHWA guidelines, each member is given a rating between 0 and 9, where 9 indicates a perfect member. Bridges with ratings lower than 4 are classified as needing rehabilitation. Currently the ratings are set based on a subjective assessment by a team of inspectors. Hence, there is a need to develop more objective and comprehensive test and evaluation procedures based on continuous monitoring of the following:

- corrosion – the presence and rate of corrosion;
- cracking – the location and opening of the cracks; and
- loads –the number and magnitude of load.

The three items listed above point to the three primary causes of deterioration in the structure. In addition, the monitoring program can be extended to detect changes in the stiffness and reactions. The damage assessed through these continuous monitoring programs can then be integrated into the existing guidelines to produce a more informed judgment about the condition of the structure.



## **Corrosion Monitoring**

To summarize, the problem of corrosion in bridge superstructure elements can be thought to be comprised of two distinct corrosion mechanisms, corrosion initiation and propagation in (a) un-cracked concrete, and (b) cracked concrete, each with its own distinctive time-scale and pattern of distress. For example, corrosion initiation requires a considerable amount of time in uncracked concrete when compared to the case of cracked concrete.

In the case of uncracked concrete, corrosion is induced when depassivating agents such as chlorides or carbon dioxides diffuse through the concrete and initiate corrosion. Further propagation of corrosion depends upon the transport of oxygen, chlorides and moisture through the concrete by a diffusion-based mechanism. The conventional theory of diffusion controlled initiation and propagation is applicable to this situation. This type of corrosion can be expected to happen in the region where the concrete is in compression, such as in the compression zone in the positive bending moment region of a composite bridge. In this situation, the signs of distress are often hidden from the eye until spalling occurs. The spalling in this case is initiated by cracking along the reinforcement. In some cases rust stains might be visible on the concrete surface prior to spalling.

The second case pertains to corrosion in cracked concrete. In this case, the depassivating agents are introduced onto the steel through the cracks. The corrosion in this case tends to be very localized, within a small portion of the rebar close to the crack, acting as the anode. In this region, which is supported by a larger cathode in the uncracked portion, the metal corrodes actively and enters into solution. Initiation and propagation of corrosion in this case are considerably faster than corrosion in uncracked concrete. Also, the initiation phase in this case is not a diffusion-based process, but is achieved through mass transport of the depassivating agents through the crack. This type of corrosion can be expected in regions where transverse cracks, perpendicular to the main reinforcement, exist in the structure, such as in the deck of a continuous span composite bridge in the negative moment region, or in the tension zone of the positive moment region in a reinforced concrete girder. Formation of corrosion-induced cracks, along the lines of the reinforcement, then produces a pattern of cracks perpendicular to the existing cracks.

### **Existing Instrumentation and Uses**

Monitoring for corrosion is carried out through manual inspection using instruments that provide surface measurements. Such inspections are typically performed at discrete intervals of time. Currently, sensors and instrumentation for detecting the location and determining the rate of corrosion, which can be embedded in concrete are available. These sensors utilize different electrochemical measurements to arrive at a decision regarding corrosion and allow for continuous monitoring of the structure. One such example is shown below in Figure C1. Through embedded instrumentation it is possible to generate the profiles of chlorides in the bridge decks and also infer about the areas in

need of cathodic protection. A list of the different sensors available for use in corrosion monitoring, are provided in Appendix C1.

As shown in Figure C1, cracks are produced in the bridge structure at areas of high stress such as the negative moment at the supports. In addition, cracks result from other causes like restrained shrinkage, thermal effects, etc. Bridge decks in particular are very susceptible to cracking produced by restrained shrinkage and thermal strains. Such cracks are usually full depth transverse cracks, which open further due to the applied loading. Lately, there has also been a growing awareness about the role of existing cracks in corrosion initiation and propagation in reinforced concrete structures. Figure C2 illustrates the occurrence of corrosion in cracked and uncracked concrete.

The monitoring for corrosion primarily comprises of visual inspections at discrete periods of time. During a typical bridge condition survey, the number, location and openings of the cracks are recorded. The procedure for measuring cracks are provided in ACI Committee Report 224.4R ("Causes, Evaluation and Repair of Cracks in Concrete Structures," ACI Committee 224 Report, ACI 1993).<sup>(31)</sup>

Recently several sensors, which provide for continuous monitoring of crack opening once a crack forms, have become available. These sensors are both embedded and surface mounted types. The embedded sensors are placed in the concrete at the time of concrete pour and provide continuous information about the deformations of the deformations produced by stress (caused by either load or environmental causes). The surface mounted sensors are primarily attached to the surface, across the crack and provide information about the opening of the crack.

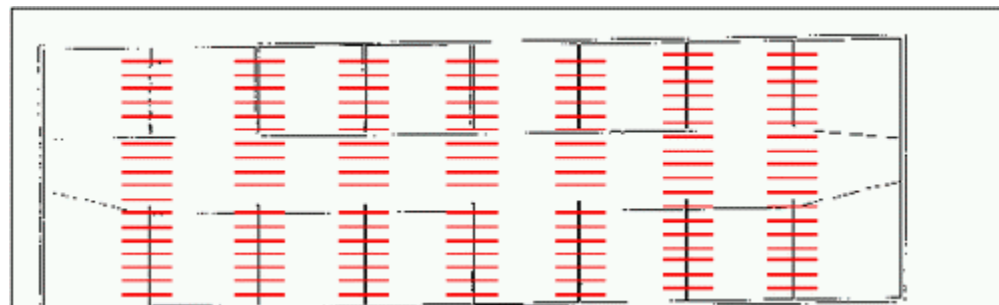

**Figure C1-a. Identification of Critical Reinforcement**

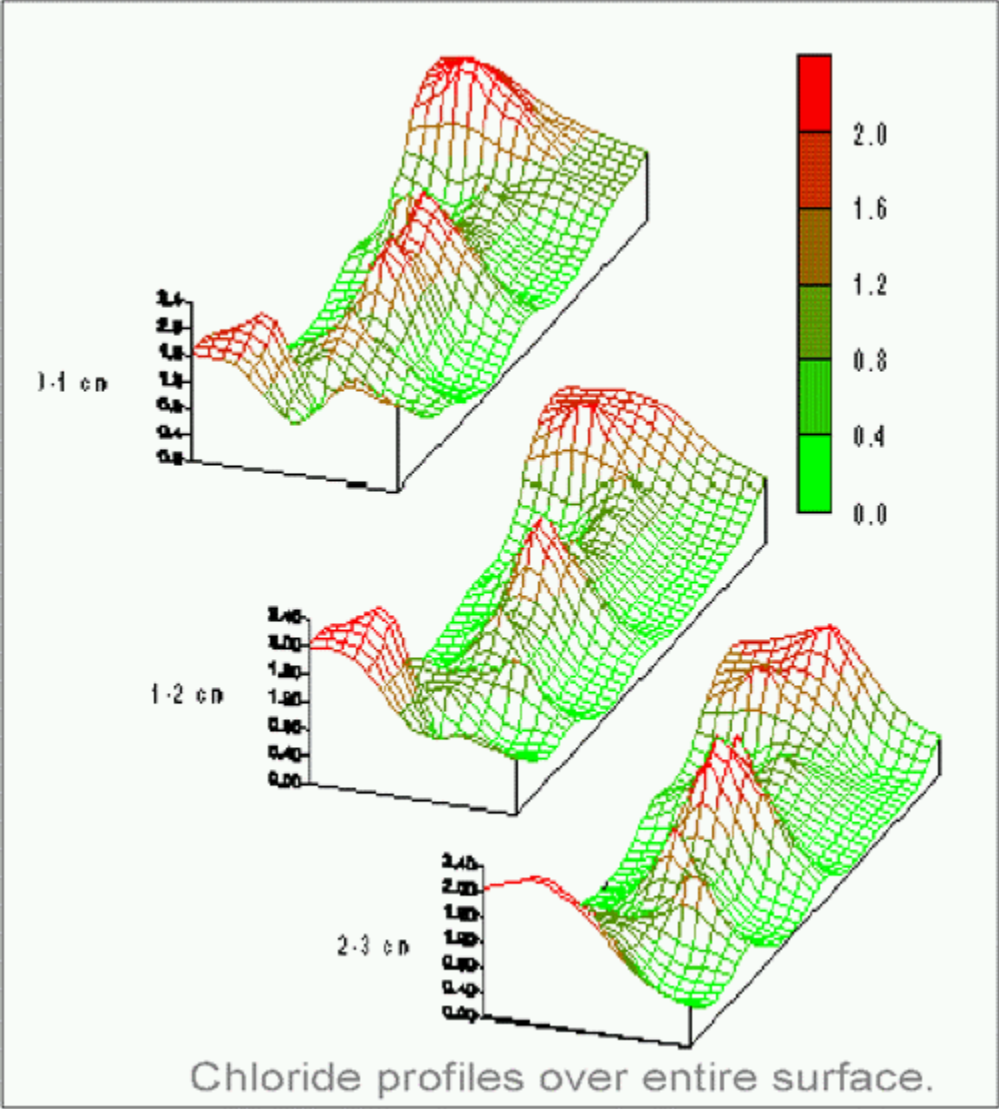

Figure C1-b. Chloride Content in 3 Depths

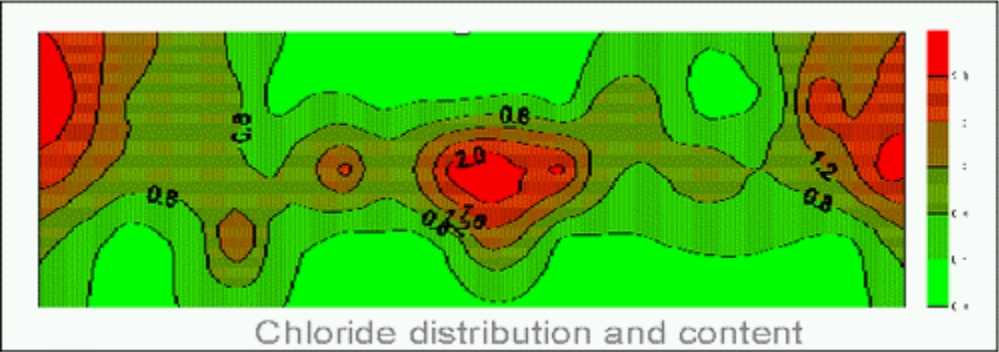

Figure C1-c. Chloride Content / Identified Areas (100 cores)



Figure C1-d. Recommended Areas for Anode (C/P) Report

**Figure C1. Monitoring Chlorides for Cathodic Protection**

Corrosion in cracked concrete resulting from deicing salts

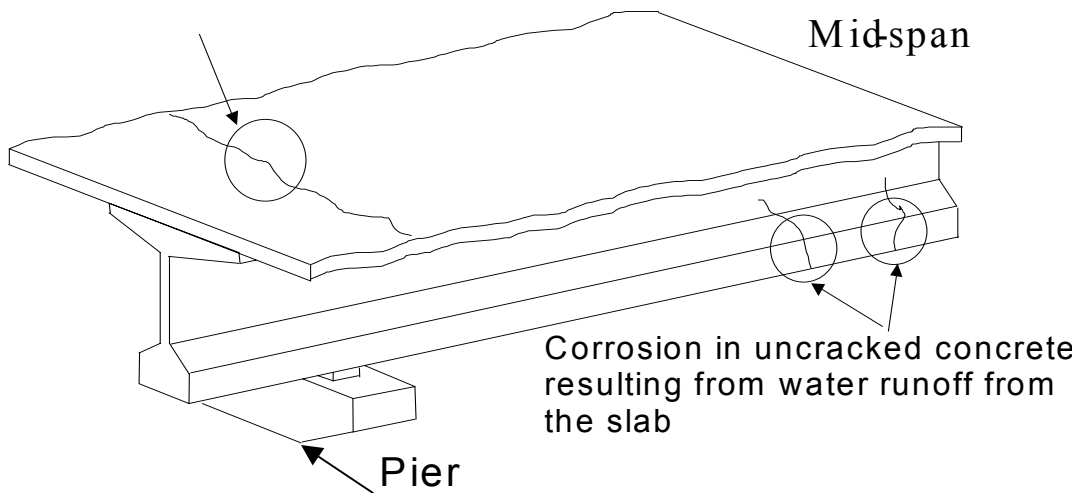

**Figure C2. Schematic Illustration of Occurrence of Corrosion in Cracked and Un-Cracked Concrete**

***Embedded Sensors***

These are primarily fiber-optic sensors and rely on transmission of light through a fiber-optic cable embedded in concrete. Once they are placed in concrete, the formation of cracks can be detected by the sudden jump in the light transmitted through the cable. The location of the cracks along the length of the cable can be located by using techniques such as optical time domain reflectometry (OTDR). OTDR has been applied successfully to locate movement of soil in embankments, subsidence of ground, pier

and abutment movement. (<http://www.iti.northwestern.edu/publications/dowding/dowding.html>). Applications in concrete are limited and still in the research stage. (<http://www.uic.edu/depts/cme/research/ssndtl/activities/6.html>). Most of the embedded fiber-optic sensors for crack location are still under development and research is currently underway to use this technology to measure the crack openings; are yet to be field-tested. A brief description of some of these sensors is given in Appendix C2.

### **Surface Sensors**

Surface mounted sensors provide for monitoring of surface strains in concrete and steel structures. Such sensors can be directly attached to the surface of the structural element and continuous monitoring of strains can be performed using the instrumentation. These sensors are either the fiber-optic kind or have mechanical moving parts.

### **Monitoring In-Service Corrosion – Methods and Techniques**

Each year, corrosion causes billions of dollars of material damage and downtime. Worse still, corrosion can cause catastrophic failures with potentially severe consequences for the environment and even loss of life. It is necessary today to be able to identify potential problems and risks through a corrosion management program. Following is a summary of the different methods and techniques that have been developed for monitoring the presence of corrosion and also determine the rate of corrosion. Several probes and portable measuring devices are currently available commercially and these are summarized below.

### **Passive Measurement Systems**

#### ***Half Cell Measurements***

In this method of corrosion monitoring, the electrical potential between reinforcing steel and a reference electrode is measured. The reference electrode is called a half-cell and consists of a metal rod immersed in a solution of its own ions of a known concentration. The half-cell provides a constant reference potential against which the potential of the corroding reinforcement can be measured.

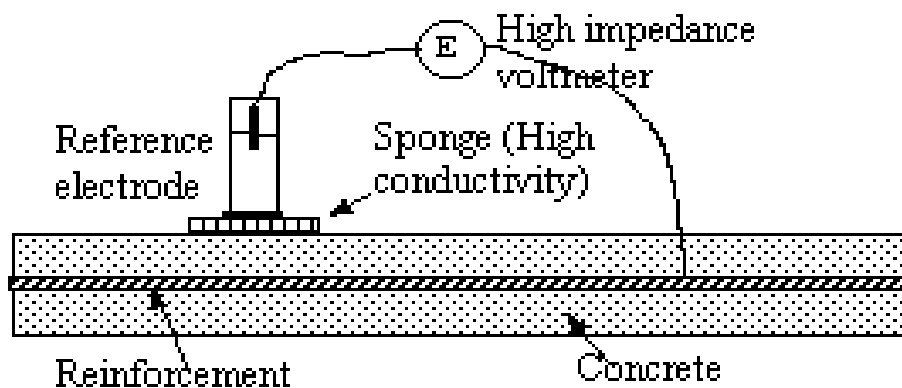

**Figure C3. Principle of the Half-Cell Method**

A typical schematic diagram of half-cell measurements is shown in Figure C3. In this setup the half-cell is connected with the steel rebar through a high impedance voltmeter. The electrical contact of the reference electrode with the concrete surface is provided by a moist plug. The potential measured at different points on the concrete surface are influenced by the corrosion reaction of the steel. The measuring method is based on many measurements of potential and correlation of measured potentials with observed corrosion rate at reinforcement. Table C1 presents criteria according to ASTM C-876 standard for copper-copper sulphate electrode, and also for calomel and silver-silver chloride. The main application of this method is in situ.

**Table C1. Interpretation of Corrosion Potential Measurements**

Cu/CuSO <sub>4</sub>	Calomel (SCE)	Ag/AgCl	Interpretation
E > -200mV	E > -126mV	E > -119mV	Greater than 90% probability that no corrosion is occurring
-200mV < E < -350mV	-126mV < E < -276mV	-119mV < E < -269mV	Corrosion activity is uncertain
E < -350mV	E < -276mV	E < -269mV	Greater than 90% probability that no corrosion is occurring

**Hand Held Equipment**

Portable setups that allow for multi-point readings by moving across the concrete surface to be investigated, and measuring the electrode potentials, have also been developed. Equi-potential lines are drawn from the measured potential to identify the corrosion areas. Extra devices have also been constructed to accelerate measuring.

**Embedded Reference Electrodes**

Potential measured by means of reference electrodes that are placed on the concrete surface are not accurate, because there is a concrete layer between half-cell and steel with variations in resistance and thickness. Reference electrodes/half-cells can be embedded in concrete close to the reinforcing steel to avoid negative effects of the concrete layer. Different embedded reference electrodes are currently commercially available. Pseudo-reference mixed metal oxide electrodes (Figure C4) consists of mixed metal oxide activated titanium rods, cast in a specially developed cementitious body, which has long term stability of electrochemical potential. Details are given in Appendix C1. The ERE 20-Embeddable reference electrode, developed and manufactured by the FORCE Institute uses a manganese dioxide electrode in a steel housing with an alkaline, chloride free gel (Figure.C5).<sup>(5)</sup> This electrode is marketed in the US by Germann Instruments. Another embedded reference sensor is manufactured by the Austrian Ingenierbüro Wietek (Figure.C6).<sup>(6)</sup> The PVC covered sensor in the form of a wire is wrapped around the steel to be monitored. A potential between the steel and electrode can be measured by using the half-cell. The advantage of the method is great

sensitivity, which makes the method suitable for measurements of pitting corrosion in large concrete structures.

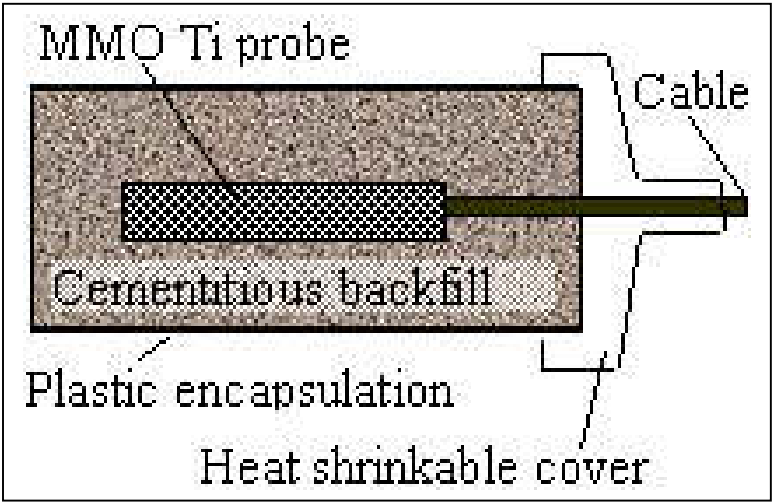

**Figure C4. MMO Ti Probe**



**Figure C5. ERE 20 Probe**

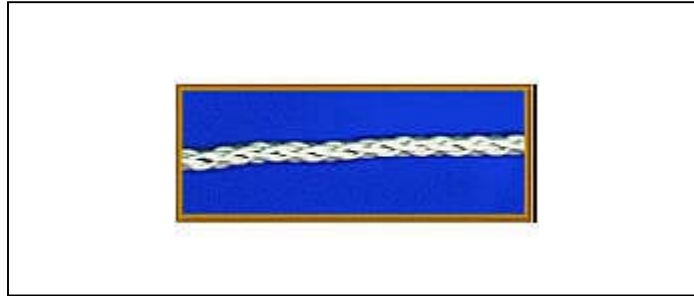

**Figure C6. Wire Sensor**

**Corrosion Macrocell Current Measurement**

During the corrosion process, corrosion macrocells are formed with a distribution of anodic and cathodic areas. Voltage in a macrocell element, equal to potential difference between active and passive steel, gives the corrosion current:

$$I = DU / (R_E + R_A + R_C) \dots\dots\dots (C-1)$$

where,

- I = electrical current (mA)
- DU = voltage in the macrocell element (mV)
- R<sub>E</sub> = concrete electrical resistance (W)
- R<sub>A</sub> = anode reaction electrical resistance (W)
- R<sub>C</sub> = cathode reaction electrical resistance (W)

The mass of the steel loss can be directly calculated from the Faraday law:

$$mass\ lost\ [g/cm^2] = \frac{i_{corr} t W_m}{F} \dots\dots\dots (C-2)$$

where,

- W<sub>m</sub> = molecular mass (g/mol)
- t = time (s)
- V = valence
- F = Faraday constant (96500 C)

Different measuring configurations for in-situ testing of macro-cell have been developed. Figure C7 shows a measuring system developed by Schiessel and Rupach.<sup>(7, 8)</sup> The system consists of the steel electrodes and insulating supports. The sensor can be built in a new construction or during repairs. Steel electrodes are placed at different depths



which makes depassivation front monitoring possible. Another configuration is a Corrowatch Multiprobe manufactured by Germann Instruments (Figure. C8).<sup>(5)</sup> A multi-probe test unit (Figure C9) developed by the Swedish FORCE Institute consists of 20 embedded steel electrodes, which are potentiostatically held at a fixed potential. The test unit is exposed to chloride ions diffusing from one side. Initiation of corrosion can be detected by a sudden rise in the anodic current.<sup>(7)</sup> These test methods have an advantage in providing direct indication of electrochemical activity in the system.



**Figure C7. Schiessel Probe**

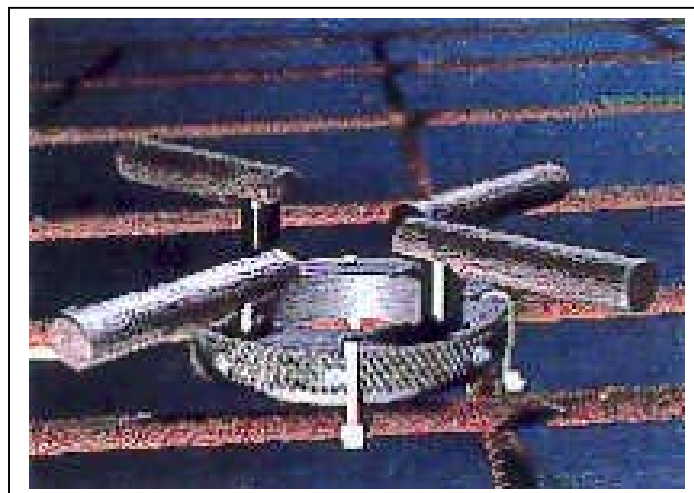

**Figure C8. Corrowatch Probe**

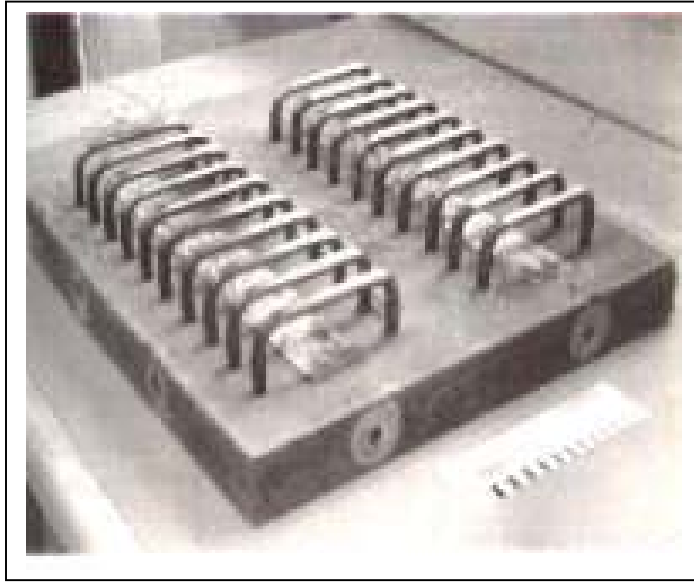

**Figure C9. FORCE Probe**

**Electrochemical Noise**

Fluctuations of potential and current, generated spontaneously by the corrosion process, make electrochemical noise. Analysis of fluctuations after spectral decomposition gives not only findings of corrosion, but characterization of the corrosion process. The advantage of the electrochemical noise method is absence of external current or voltages supply which perturbate the system. Measured signals can be analyzed by mathematical analysis. In the case of complicated kinds of corrosion, like metastable pitting corrosion or corrosion inhibitor induced by unstable passivation, mathematical analysis becomes unsuccessful, and some researchers suggest application of chaos theory to corrosion electrochemistry.<sup>(9)</sup>

**Polarization Measurements**

**Linear Polarization Method**

In the linear polarization method, a potential scan in the range  $E_{corr} \pm 25\text{mV}$  is applied to the specimen and the resulting current is measured. The resulting current exhibits a linear dependence versus the potential, which can be evaluated from the equation:

$$i_{corr} = \frac{\beta_a \beta_c}{2.3(\beta_a + \beta_c)} \cdot \frac{\Delta i}{\Delta E} \dots\dots\dots (C-3)$$

Polarization resistance  $R_p$  is defined as the rate between the applied current  $\Delta i$ , and the potential response  $\Delta E$ :

$$R_p = \frac{\Delta E}{\Delta i} = \frac{B}{i_{corr}} \quad \text{where,} \quad B = \frac{\beta_a \beta_c}{2.3(\beta_a + \beta_c)} \quad \dots\dots\dots (C-4)$$

and,

- $\Delta i$  - applied current (mA)
- $\Delta E$  -potential response (mV)
- $i_{corr}$  -corrosion intensity ( $\mu\text{A}/\text{cm}^2$ )
- $R_p$  - polarisation resistance ( $\text{k}\Omega$ )
- $B$  - value of 13 to 52 mV in the most metal / media systems
- $\beta_a$  - anodic Taffel constant
- $\beta_c$ -cathodic Taffel constant

This is Stern-Geary relation, which is used for corrosion current calculation. The linear polarisation technique has been used widely in laboratory work for corrosion rate determination, but some modifications are needed for its application to structures in the field.<sup>(10)</sup>

**Hand Held Equipment**

A practical difficulty with the linear polarisation technique is requirement for determination of area of steel being polarised without which accurate corrosion determination can not be achieved. This problem is avoided by use of an extra ring electrode placed around the central electrode. In this way, signal application is limited at the known rebar area. Based on this principle, in situ devices are developed. "Gecor 6" (Figure C10) consists of the rate meter that automatically controls the system and two sensors. Sensor A is for the corrosion rate and half-cell measurements and sensor B is for the concrete resistivity, temperature and relative humidity measurements.<sup>(11)</sup> This equipment is manufactured and distributed by James Instruments. Another device is MS 4500 Polarisation Resistance Monitor for accurate determination of polarisation resistance even in high resistance concrete environments (Figure C11).<sup>(12)</sup>



**Figure C10. Gecor 6**



**Figure C11. MS 4500 Polarization Device**

***Embeddable Linear Polarisation Sensors***

Embeddable minisensors have developed on the basis of the linear polarisation principle. Different types of minisensors are commercially available. The C-probe CP100 (Figure C12) is a combination of silver/silver chloride reference half cell and graphite counter electrode.<sup>(7)</sup> CORROATER 800/800T (Figure C13) is manufactured using carbon steel, and measures corrosion rate of reinforcing steel in concrete.<sup>(12)</sup> Details of this sensor are given in Appendix C4. General Building Research Corporation of Japan developed a sensor, as shown in the Figure C14. Three electrochemical characteristics of natural potential, polarization resistance and electrolyte resistance can be measured.<sup>(13)</sup> All these probes have the possibility of automated measurements, using computer-controlled equipment.

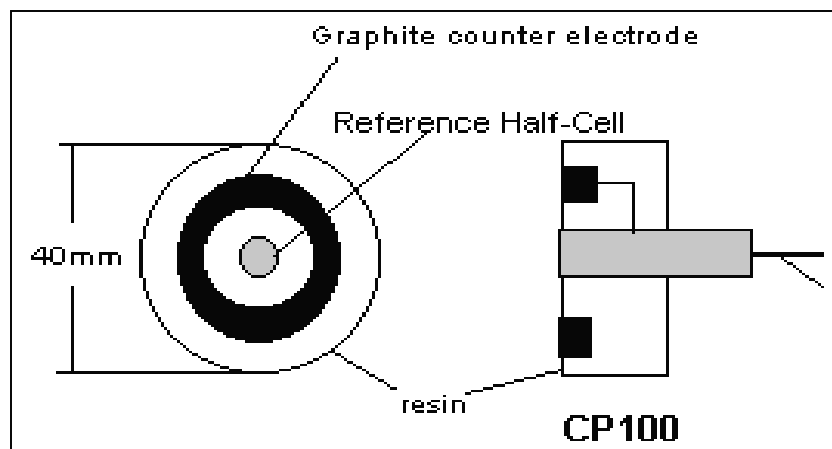

**Figure C12. C-Probe Type CP 100**



**Figure C13. CORROATER**

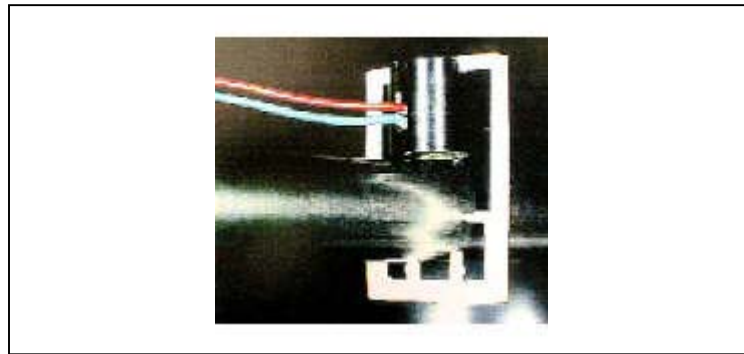

**Figure C14. Minisensor**

### **Electrochemical Impedance Spectroscopy (EIS)**

Electrochemical impedance spectroscopy (EIS) uses polarization with alternating current. Instrumentation for measurements is more sophisticated than for other polarization measurements, consisting of a potentiostat and spectrum analyser. Reinforcement is maintained at its corrosion potential  $E_{\text{corr}}$  by the potentiostat, with application of a sinusoidal potential (10 to 20 mV) in a wide frequency range. The response at input signal is also sinusoidal with phase shift relative to the input signal. The EIS method in its basic formulation is very attractive because it can determine polarisation resistance and add extra information about the corrosion process. High frequency range can give information about dielectric properties of concrete, and low frequency range information about dielectric properties of passivity film on the steel. In spite of these possibilities, the method has not had wide application to reinforced concrete, because diagrams become complex and difficult to interpret.<sup>(14)</sup>

### ***Localised electrochemical impedance spectroscopy (LEIS)***

Data obtained by the conventional EIS technique are averaged across the entire area of the sample, and this technique is therefore not suitable for application for chloride induced pitting corrosion. To avoid problems, localised electrochemical impedance

spectroscopy (LEIS) is developed.<sup>(15)</sup> The principles of LEIS are similar to those in conventional EIS, but LEIS combines both established direct current scanning probe methods with alternating current impedance techniques. The probe consists of two separate platinised electrodes. The first electrode has a tip, which is electrochemically sharpened to 5 mm in diameter. The second ring electrode is positioned at a fixed distance of 2-3 mm away from the tip electrode. This method is suitable for the corrosion inhibitor effectiveness investigation.

**Galvanomic Pulse Method**

A short time anodic pulse (typically 8 s) is applied galvanostatically on the reinforcement and the resulting change in potential is monitored. Potentials are measured with a reference electrode and the high impedance voltmeter. When a current impulse  $I_{app}$  is applied to a corrosion system, the potential  $V$ , as a function of time, can be expressed as:<sup>(16)</sup>

$$V_t = I_{app} \left[ R_p \left[ 1 - \exp \left( - t / (R_p C_{dl}) \right) \right] + R_{\Omega} \right] \dots\dots\dots (C-5)$$

where,

- $R_p$  = polarisation resistance (W)
- $C_{dl}$  = capacity of double layer (mF)
- $R_w$  = ohmic resistance (W)

The Galvanostatic pulse method allows rapid measurements of polarisation resistance, ohmic resistance and open circuit potential. An example of an instrument used in this method is GalvaPulse by the Gemann Instruments (Figure C15). This is a rapid non-destructive device for determining the corrosion rate of reinforcement in concrete. The device is equipped with software, which enables displaying the corrosion rate, electrical resistance and half-cell potential, together with the graphs of the galvanostatic pulse.<sup>(5)</sup>

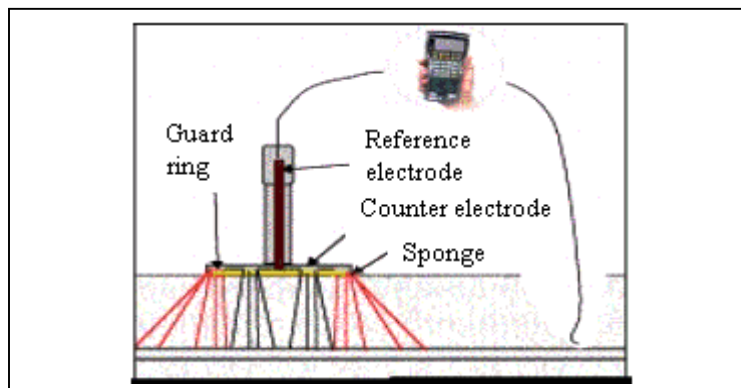

**Figure C15. The GalvaPulse Device**

### **Scanning Reference Electrode Method (SRET)**

In localised corrosion, anodic and cathodic reactions usually occur at separate sites. These reactions produce small but measurable ionic transport in the electrolyte local to the anodic and cathodic sites. The scanning reference electrode technique (SRET) measures microgalvanic potentials existing locally on the surface of the specimen using uniquely designed scanning electrode. Specimens rotate in a solution by means of a stepper electromotor. Measurement is made by means of the scanning electrode and differential amplifier, which gives a two-dimensional picture of any region of interest. The method allows dynamical information of corrosion activity, which has been done by the variations of ionic flow at the microscopic scale. The SRET method can be used for passivation research of corrosion at grain boundaries, and cracking under corrosion induced strain.<sup>(17)</sup>

### **Nonelectrochemical Methods**

Many nonelectrochemical methods, are suitable for determining corrosion of reinforced steel in concrete.<sup>(18, 19, 20, and 21)</sup> These methods are, however, still very much in their early experimental stages.

### **Current Developments**

#### ***Embedded Corrosion Microsensor***

In cooperation with the Virginia Transportation Research Council an embedded micro sensor is being developed to quantitatively measure corrosion activity inside concrete.<sup>(23)</sup> In this very large scale application, specific integrated circuits will provide electrochemical measurements of corrosion rate with polarization resistance, and measure chemical parameters such as pH, chloride ion concentration and temperature in an embeddable package. The sensor will be powered and it will telemeter sensor data via wireless communications. The objective is to develop a small and inexpensive package that will allow hundreds or thousands of sensors to be embedded in concrete structures. It will then be possible to quickly scan a concrete structure, and quantitatively measure the rate and location of corrosion before visible deterioration occurs. A prototype integrated circuit has been fabricated and further development is ongoing.

Chloride threshold sensors (Smart Pebbles<sup>TM</sup>) are also currently under development for the California Department of Transportation (<http://crvax.sri.com/topics/SensorTags.html>). These devices can be embedded in bridges to monitor chloride ingress. Knowledge of chloride diffusion into bridge-deck concrete is important in prioritizing remediation steps to protect the underlying rebar from corrosion. The first prototype is currently under construction. For this first device the sensor is embedded in a known location in a bridge and its change is monitored over time. In the future, these devices could be inserted into new concrete pours. A van-mounted reader could drive over the bridge to obtain chloride-threshold data from the embedded sensors. Using GPS positioning, the van could automatically update the health of the bridge in the bridge database.

An in-situ impedance sensor is also currently under development by Dacco, (<http://www.daccosci.com>) with the following features:

- The patented *in-situ* sensor (additional patents pending) uses electrochemical impedance spectroscopy (EIS) to monitor degradation of structures in the laboratory and in the field.
- The measurements obtained with the sensor are identical with those obtained using conventional remote electrodes. This assures that the methodology and analyses established for the conventional EIS measurements are suitable for the corrosion sensor results.
- Two sensor versions are available: a permanent, attached sensor and a portable hand-held sensor. The incorporated sensor is especially suited for areas that are not readily accessible or that require frequent inspection/monitoring. The hand-held sensor is suitable for spot inspection and areas where a permanent sensor is not desired for cosmetic, aerodynamic, or other reasons. Identical results are obtained with the two sensor versions.
- Sensor EIS data correlate very well with corrosion rate measurements.
- The corrosion sensor is suitable for use in a variety of environments, including immersion, salt fog, humidity, and aggressive atmospheres as well as ambient service environments.
- The sensor is suitable for a variety of metal substrates and coating chemistries. In particular, it has been demonstrated on aluminum and cold rolled, electrogalvanized, and galvanealed steel substrates and on epoxy, polyamide, urethane, and alkyd primers/paints and epoxy adhesives. No limitation in the substrate or coating is anticipated provided the substrate is conductive and the coating is non-conducting.
- Differences in relative coating effectiveness are easily observed.
- The sensor detects very early stages of paint degradation and corrosion before any visual indications. This detection of corrosion before any structural damage has occurred is important. It potentially allows the health of the painted structure to be monitored so that maintenance can be scheduled on a condition or needs basis instead of a fixed time interval basis.
- Sensor measurements during a 5-month cyclic test have been correlated with amount of corrosion at the end of the test. This test has, in turn, been correlated with performance in the field.

### **Monitoring Strains and Cracks**

These sensors consist of both surface mounted and embedded types, and are primarily used for monitoring the strain (and hence the stress) in the material and the relative displacement of crack faces which would indicate opening or closing of a crack. There are three types of sensors that are available:



- Vibrating wire strain gages
- Crack meter
- Embedded strain gage

### **Vibrating Wire Strain Gauge**

This strain gauge operates on the principle that a tensioned wire, when plucked, vibrates at a frequency that is proportional to the strain in the wire. The gauge is constructed so that a wire is held in tension inside a small diameter, thin-walled tube that is welded to the structural member. Loading of the structural member changes the length of the tube and results in a change in the tension of the wire. An electromagnet in the strain gauge sensor is used to pluck the wire and measure the frequency of vibration. Strain is calculated by applying calibration factors to the frequency measurement.

### **Crack Meter**

The crack meter consists of a displacement sensor and a mounting kit with groutable anchors. The anchors are installed on opposite sides of the crack. The sensor is then fixed to the anchors. Swivel joints accommodate movement on other planes. Readings are taken with a readout or a data logger. Calibration factors are applied to the frequency readings to convert them to a distance in mm and inches. The initial reading establishes a baseline. Subsequent readings are compared to the baseline to determine the magnitude of changes in the distance across the crack.

### **Embedment Strain Gauge**

These strain gauges are used to measure strain in reinforced concrete and mass concrete structures. The design concept is the same as the Spot-Weldable Strain Gauge. During installation, the strain gauge is usually tied to the reinforcing cage. Some specifications require that a gauge be cast in a concrete cage prior to installation.

## **Deflections/Displacement Monitoring and In-Service Performance**

In many bridges, the displacements are the most relevant parameter to be monitored in both the short and long term. Current methods include triangulation, hydrostatic leveling, vibrating strings and mechanical extensometer. The instrumentation for continuous monitoring of deflections essentially relies on strain-gage based or mechanical extensometers.

A brief description of the different sensors available for this purpose is provided below. A brief description of some of the commercially available sensors for such measurements is given in Appendix C2.

The different types of sensors available for monitoring the deflections/displacements are:

- Beam sensor
- Multi-point liquid level system
- Direct and inverted pendulum
- Fiber optic sensors

## **Beam Sensor**

Beam sensors are used to monitor differential movement and rotation in structures. Horizontal beam sensors monitor settlement and heave. Vertical beam sensors monitor lateral displacement and deformation. The beam sensor consists of an electrolytic tilt sensor attached to a rigid metal beam. The tilt sensor is a precision bubble-level that is sensed electrically as a resistance bridge. The bridge circuit outputs a voltage proportional to the tilt of the sensor. The beam, which is typically one to two meters long, is mounted on anchor bolts that are set into the structure. Movement of the structure changes the tilt of the beam and the output of the sensor. The voltage reading from the sensor is converted to a tilt reading in mm per meter. Displacements are then calculated by subtracting the initial tilt reading from the current reading and multiplying by the gauge length of the sensor (the distance between anchors). When sensors are linked end-to-end, displacement values can be accumulated from anchor to anchor to provide differential movements and settlement.

Advantages of the beam sensor are as follows:

**High resolution** - The beam sensor can detect a movement as small as 0.005mm per meter of gauge length.

**Easy installation** - The low profile beam fits nearly anywhere. The length of the beam can be modified to fit the structure, and special mounting brackets provide easy installation on curved surface.

**Simple and robust** - The electrolytic tilt sensor has no moving parts.

**Ready for data logging** - Beam sensors can be connected to a data acquisition system. Such systems can monitor continuously and trigger alarms when threatening movements are detected.

## **Multipoint Liquid Level System**

The multipoint liquid level system is used to monitor small changes in the elevation of settlement gauges that are distributed around a structure. Components of the system include an automatic level controller, tubing, and a number of settlement gauges. The automatic level controller is installed at a stable location outside the area affected by settlement. The settlement gauges are fixed to the structure at selected locations at the approximate elevation of the level controller. Tubing connects each settlement gauge to the automatic level controller. Liquid is pumped into the tubing and gauges until the liquid within each gauge rises to the same elevation as the liquid in the level controller. The level controller then holds the elevation of the liquid constant by means of a pump, reservoir, and overflow unit. Sensors monitor the height of the liquid within each gauge. When settlement or heave occurs, the sensor detects an apparent change in the height of the liquid. In fact, the gauge and the sensor have moved relative to the elevation of the liquid surface, which has remained constant. The system is connected to a data logger that provides continuous monitoring and stores readings in memory. Settlement

or heave is calculated by comparing the current reading from each sensor to the reference level and applying corrections for temperature.

Advantages of the multi-point liquid level sensor are as follows:

- **Accurate readings** - The liquid level system can provide an accuracy of  $\pm 0.3\text{mm}$ .
- **Settlement profile** - Measurements provided by the settlement gauges can be used to compute settlement profile
- **Automatic data collection** - The settlement system can be connected to a data acquisition system for fulltime, unattended monitoring. The logger stores both level and temperature readings.

### **Direct and Inverted Pendulum**

Direct and inverted pendulums are designed to accurately measure the relative internal horizontal displacement of points along a true vertical line.

#### ***Direct Pendulum***

The direct pendulum is comprised of a wire suspended from the upper point and a reading station fixed to the structure at a lower point. The wire is tensioned by a suspended weight submerged in a damper tank

#### ***Inverted Pendulum***

The fixed end of the inverted pendulum is grouted at the lower point of the system. The wire is tensioned vertically by a float. When anchored in a fixed point in the foundation, it measures absolute displacement of points along the wire

Monitoring wire position for both direct and indirect pendulums can be done manually and/or electrically with a remote readout unit. The method of reading depends on the concept of monitoring, the expected values of movements, and the accuracy required.

Advantages of the pendulum sensor are as follows:

- High accuracy and resolution
- Long-term reliability
- Easy installation

### **Fiber Optic Sensor Types**

Conventional sensors such as strain gauges, extensometers, and inclinometers are able to provide sufficient and reliable results for supervising the structures. However, fiber optic sensors offer a better solution for engineers to monitor bridges due to its

better reliability, lower lifetime cost, insensitivity to electromagnetic field and corrosion, small size and the high density of information they can deliver remotely.

The main components of a fiber optic monitoring system are sensors, carrier of information, reading units, interfaces, and data managing subsystems. The aim of sensors is to detect the magnitude of monitored parameters and transform it to transportable information. There are four types of sensors:

- Interferometry-based displacement sensors
- Microbending displacement sensors
- Bragg Grating strain sensors
- Fabry-Perot strain Sensors

### ***Interferometry-Based Displacement Sensors***

The measuring system is based on the principle of low-coherence interferometry. The infrared radiation of a light emitting diode (LED) is injected into a standard single mode fiber and directed, through a coupler, towards two fibers installed inside the structure to be monitored. The measurement fiber is in mechanical contact with the structure itself and will therefore follow its deformations in both elongation and shortening. The second fiber, called reference fiber, is installed free in the same pipe. Mirrors, placed at the end of both fibers, reflect the light back to the coupler, which recombines the two beams and directs them toward the analyzer. This one is also made of two fiber lines and can introduce a well-known path difference between them by means of a mobile mirror. On moving this mirror, a modulated signal is obtained on the photodiode only when the length difference between the fibers in the analyzer compensates the length difference between the fibers in the structure to better than the coherence length of the source (of the order of hundreds of nm). Each measurement gives a new compensation position reflecting the deformation undergone by the structure relative to the previous measurement points. One such sensor, which is available commercially is the SOFO system, described in Appendix C2.4.

### ***Microbending Displacement Sensor***

In the principle of microbending, an optical fiber is twisted with one or more other fibers or with metallic wires along its sensing length. When this fiber optic twisted pair is elongated, the fibers will induce bending in one another and cause part of the light to escape the fiber. By measuring the intensity of the transmitted light it is possible to reconstruct the deformation undergone by the structure on which the sensor is mounted. Microbending sensors are conceptually simple, however temperature compensation, intensity drifts, system calibration and the inherently non-linear relationship between intensity and elongation still present some challenges. This type of sensor seems particularly appropriate for short-term and dynamic monitoring, as well as for issuing alarms.

### ***Bragg Grating Strain Sensors***

Bragg gratings are periodic alterations in the index of refraction of the fiber core that can be produced by adequately exposing the fiber to intense UV light. The produced

gratings typically have lengths of the order of 10 mm. If white light is injected in the fiber containing the grating, the wavelength corresponding to the grating pitch will be reflected while all other wavelengths will pass through the grating undisturbed. Since the grating period is strain and temperature dependent, it becomes possible to measure these two parameters by analyzing the spectrum of the reflected light. This is typically done using a tuneable filter or a spectrometer.

The main interest in using Bragg grating resides in their multiplexing potential. Many gratings can be written in the same fiber at different locations and tuned to reflect at different wavelength. This allows the measurement of strain at different places along a fiber using a single cable. Typically, 4 to 16 gratings can be measured on a single fiber line. It has to be noticed that since the gratings have to share the spectrum of the source used to illuminate them, there is a trade-off between the number of gratings and the dynamic range of the measurement on each of them. Because of their length, fiber Bragg gratings can be used as replacement of conventional strain gages and installed by gluing them on metals and other smooth surfaces.

### ***Fabry-Perot Strain Sensors***

Extrinsic Fabry-Perot Interferometers (EFPIs) are constituted by a capillary silica tube containing two cleaved optical fibers facing each other, but leaving an air gap of a few microns or tens of microns between them. When light is launched into one of the fibers, a back-reflected interference signal is obtained. This is due to the reflection of the incoming light on the glass-to-air and on air-to-glass interfaces. This interference can be demodulated using coherent or low-coherence techniques to reconstruct the changes in the fiber spacing. Since the two fibers are attached to the capillary tube near its two extremities (with a typical spacing of 10mm), the gap change will correspond to the average strain variation between the two attachment points.

### ***Advantages of Fiber Optic Sensors***

Fiber Optic Sensors have many advantages over traditional electrical/mechanical strain gauges. Some of the advantages include:

- EMI resistance Fiber sensors are virtually unaffected by electromagnetic Interference.
- Much less intrusive size uncoated sensors have diameter of 125 $\mu\text{m}$ , with coated (polyimide, for example) diameters of 150  $\mu\text{m}$  – ideal sizes for embedding into metals and composites.
- Higher temperature capacity .Upper range of 400°C to 650°C
- Greater multiplexing potential. Several sensors can be multiplexed along a single fiber line with multiple lines connected to a single demodulator.
- Longer distance. Being fiber optic based, these sensors can be demodulated up to several kilometers from sensors via a standard telecom fiber optic cable.

- Greater resistance to corrosion. Because fiber sensors do not use metal, they are less susceptible to corrosion
- Other measurement. Some Fiber sensors can detect multi-axis strain, temperature, bridge scouring, ice and traffic flow.

In many bridges, the vertical displacements are the most relevant parameter to be monitored in both the short and long term. Current methods such as triangulation, hydrostatic leveling, vibrating strings and mechanical extensometers are often tedious in their application and require the intervention of specialized operators.

### **Instrumentation of Fiber Optic Sensors (a few case studies)**

#### ***The Rio Puerco Bridge, NM, USA ([www.smartec.ch](http://www.smartec.ch))***

Professor Rola L. Idriss of New Mexico State University had done a research on monitoring the Rio Puerco Bridge (a high performance prestressed concrete bridge) in Albuquerque, NM. An optical fiber monitoring system was designed and built into the bridge. A total of 40 long-gage deformation sensors, along with thermocouples were installed in parallel pairs in the top and bottom flanges of the girders. The embedded sensors measured temperature and deformation at the support, at quarter spans and at mid span. The sensors were embedded in the girders during fabrication at the prestressing plant. The embedded sensors collected data during the following phases of the project:

- Beam fabrication (casting and steam curing of the concrete)
- Bridge construction
- Service

The data collected was analyzed to determine the prestress losses in the tendon over time, and get a better understanding of the properties and behavior of high performance concrete.

#### ***The Lutrive Bridge, Switzerland ([www.smartec.ch](http://www.smartec.ch))***

The Lutrive north and south bridges are two parallel bridges built in 1972 by the corbelling method with central articulation. The two bridges are gently curved ( $r = 1000\text{m}$ ) and each bridge is approximately 395m long on four spans. The two bridges have the same cross section, consisting of a box girder of variable height (from 2.5m to 8.5m) and two slightly asymmetrical cantilevers meant to reduce the effect of torsion in the curved bridges. The fourth span of the South Bridge, fitted with a hydrostatic leveling system measuring vertical displacement since 1988, was instrumented with 10m long SOFO sensors. To measure the curvature variations, the sensors are installed in pairs in the interior of the box girder. Curvatures are measured with sensors placed near to the top and bottom of bridge web, and the vertical displacement can be retrieved by double integration of the curvature. Results of vertical displacement

calculated with fiber optic sensors and the hydrostatic leveling system were found to be comparable.

### **Installing Fiber Optic Sensors in Civil Engineering Structures**

Generally, installation of fiber optic sensors should respond to two requirements as follows:

#### ***Optical Requirement***

The sensor has to encode a displacement of the structure into change of the length of an optical fiber. On the other hand, optical fibers present a disturbing cross sensitivity to temperature changes and to obtain a pure displacement or strain reading it is necessary to compensate for this effect. The easiest way to achieve that is to use one fiber as a measurement fiber following the structure and a reference fiber independent of it. Obviously, the fibers have to remain intact and microbending must be reduced to minimize the losses.

#### ***Mechanical Requirement***

The measurement fiber has to be in mechanical contact with the host structure. All axial displacements have to be transferred from the host structure to the fiber. Creeping effects have to be avoided since the final aim of the system is long term measurements. It was found that by using polyimide coated fiber and epoxy glues, it was possible to obtain excellent mechanical coupling between fiber and anchorage.

## **WEIGH-IN-MOTION TECHNOLOGY**

### **Overview**

Weigh-In-Motion (WIM) technology was developed over the last 25 years to weigh trucks as they travel across highway and road systems. Various government and private agencies require information on truck weights for several applications including: highway weight enforcement; traffic data collection; military and industrial operations; and monitoring of economic activity. Particular interest has recently focused on application of data collected from WIM systems for safety assessment of pavements and bridges. The advantage of WIM over traditional static scale weighing is the efficiency of being able to collect truck weight information automatically as the trucks travel at, or near, normal speeds. WIM operations may be designed to be undetectable to provide unbiased information on overweight trucks. Additionally, most WIM systems are capable of simultaneously providing information on truck traffic patterns including Average Daily Truck Traffic (ADTT), truck headways and platoon formations, as well as collecting information on long term and seasonal changes. Such information is very important for highway engineering purposes including the planning of new highway systems, increasing highway system capacities, designing pavements and bridges, monitoring the behavior and assessing the safety of existing pavements and bridges, as well as forecasting the safe lives of these pavements and bridges.

A bridge is safe as long its members are capable of withstanding the applied loads. Although much effort has been expended to develop methods to predict and monitor the

load carrying capacity and the deterioration of bridge members, little effort has been directed to estimating the magnitude and intensities of the applied loads. For short to medium span bridges, the most critical loads are those caused by the crossing of the heavy trucks. Hence, the application of WIM technology is an essential part of any smart bridge system.

Most existing WIM systems are pavement-based, providing information on truck weights and are extended to also provide information on truck traffic patterns and frequencies. A type of WIM system known as Bridge WIM or B-WIM is also capable of providing additional information on the response of critical bridge members to the applied loads thus providing a correlation between the applied loads and the response of the bridge to these loads. Such information is extremely useful for bridge rating purposes and when coupled with information on the deterioration of the bridge members would provide an invaluable tool for the health monitoring and the safety assessment of the instrumented bridge. Consequently this information may lead to future assessments of the bridge design process.

### Existing WIM Systems

Over the last two to three decades, highway agencies have recognized the advantages of having automated data collection systems that can provide information on truck weights and changes in truck traffic patterns. Several agencies spent substantial effort and resources to develop, design, and implement WIM technology for assembling truck data for planning purposes. It was observed that these data when coupled with data on truck axle weights and truck headways would serve to provide important information that is also useful for studying the safety of existing pavements and bridges. Ultimately the same information will lead to developing improved bridge design methods that take into consideration the long-term effects of the applied loads as well as the changes in these loads. Various technologies were adopted for use in WIM systems that are quickly becoming essential tools for many highway agencies. There are currently over 1000 operating WIM stations around the world, about 450 of which are in the United States, 350 in Europe, and 180 in Australia. WIM systems are also used in South Africa, South Korea, Israel, and a few other countries. Existing WIM systems may be classified into three categories:

- **Permanent:** The sensors and data acquisition systems are installed at fixed locations.
- **Semi-permanent:** The sensors are built into the pavement or a bridge while the data collection system is moved from site to site.
- **Portable:** The sensors and equipment are moved from site to site.

The various technologies that are used in WIM systems include hydraulic load cells, bending-plate strain gauges, capacitive mats, and piezoelectric and quartz sensors for pavement based systems.

Bridge WIM (B-WIM) technology, that was originally developed in the United States and a version of which has been in use in Australia for culverts, is finding renewed interest in



Europe. A web site (<http://www.ornl.gov/dp121/>) maintained by the Oak Ridge National Laboratory (ORNL) for the Federal Highway Administration (FHWA) provides a comparison between the most widely used WIM systems in the U.S. A web site (<http://wim.zag.si/>) maintained by the Slovenian National Building and Civil Engineering Institute, known by its Slovenian acronyms as ZAG, provides information on research and application of WIM technology in different European countries including B-WIM systems. Another web site that discusses the operation and maintenance of U.S. WIM systems can be found at [http://www.ctre.iastate.edu/research/wim\\_pdf/index.htm](http://www.ctre.iastate.edu/research/wim_pdf/index.htm).

The report published on the Iowa State University web site summarizes the results of a study conducted for FHWA by McCall & Vodrazka (1997). The study provides practical advice for users of WIM technology based on the experience of several states. The systems analyzed include bending plates, piezoelectric sensors, and load cells. Another report prepared by International Road Dynamics Inc (IRD) provides a comparison between four different WIM technologies. The technologies listed are: Load cell, Kistler (or Quartz) and piezoelectric cable systems, and bending plates. The report is also available on the web at [http://www.irdinc.com/english/pdf/tech\\_ppr/wim\\_tech\\_compare.pdf](http://www.irdinc.com/english/pdf/tech_ppr/wim_tech_compare.pdf). Additionally, there is considerable research effort to develop fiber-optic based WIM systems. The information assembled in this section of this report was primarily collected from the above-mentioned web sites.

The ORNL website asserts that "... choosing a WIM system for a specific application or use can be a difficult task because there are a number of technologies and systems available today. Each has its own set of advantages and limitations. For example, not all WIM systems can operate at high speeds, some can be installed in a few hours with relatively unskilled labor while others require several days of labor-intensive site preparation, and some work great for traffic data collection purposes but are not recommended for weight enforcement."

### **Bending Plates**

This system incorporates a steel/rubber plate with strain gauges attached to its underside. The gauges generate a signal proportional to the deflection of the plate under an axle. The signal is then amplified and processed to produce the vehicle's axle weights. A typical bending plate WIM system consists of two in-road weigh platforms in a travel lane providing full width lane weighing. In conjunction, an inductive loop vehicle detector and optional additional axle sensors are used to provide real-time traffic data as well as truck type and other information for storage on site. This data is either collected for analysis on site, or sent through a network communication system to a central monitoring unit for weight enforcement applications. The data collected may include the time and date of passage, vehicle speed, number and spacing of axles and the axle weights. Bending plate WIM systems are designed for low-cost operation in all weather and operating conditions. The plates can be permanently installed or may be portable.

For proper operation, the bending plate WIM site should be located on a straight section of road with uniform horizontal and vertical alignment. The site should be located where speeds will typically remain constant. In order to achieve optimum accuracy, the pavement must have a surface of asphalt or concrete that is relatively new and free from distress due to cracks or severe compression rutting. There should be no heaving or open construction joints or cracks. Special considerations must also be given to surface conditions such as International Roughness Index (IRI), lane width recommendations, speed restrictions, cross fall, pavement thickness, flatness, and re-bar or steel reinforcement placement. More information on bending plate WIM systems is provided at <http://www.ornl.gov/dp121/bp.htm>

### **Capacitive Mats**

Capacitive mats are frequently manufactured from stainless steel, brass, polyurethane, and hard rubber and have different WIM applications. A capacitive-based WIM system basically consists of two or more conductors (metal plates) carrying equal but opposite charges. The ability of a capacitor to hold a charge is measured by a quantity called the capacitance. When weight is applied to metal plate conductors having nonconducting spacers between them, the distance between the plates changes. When force is applied, the bending action of the plates results in a change in the capacitance that is measured by sensors mounted on the cell. Proprietary configurations consisting of multiple capacitors and embedded nonconducting spacers are used to provide truck axle weights. Capacitive mat WIM systems are designed for use in either permanent or portable applications. Permanently mounted capacitive mat WIM systems are typically designed for high speed weighing. A permanent site layout may consist of two inductive loops and one capacitive mat. The sensors are bolted to stainless steel installation pans that are fixed into the road pavement with suitable adhesives. They are mounted flush with the road surface and are suitable for high-speed permanent WIM applications. The inductive loops have multiple functions, including notification of presence of a vehicle, length calculation, and speed calculation. Wheel weight data is calculated as each wheel rolls over the mat and then doubled for axle weights. Axle groupings and gross weight are derived from the individual axle weights.

Portable capacitive mat WIM systems are typically designed for low speed weighing at temporary sites. The low-speed portable WIM systems consist of a data collection unit, two weigh pads, and four leveling pads. The system is completely portable, lightweight, and can be transported in the trunk of a car or back of a truck. Set-up time takes approximately 10 minutes, making it an ideal tool for weight enforcement of remote locations or for spot checks. A portable system is also ideal for industrial and military purposes to ensure that vehicles are within legal weight limits before traveling onto public roadways.

Permanent capacitive mats are known to have problems with durability, as their useful lives may be shorter than that of other WIM systems. Portable mats are not flush with the pavement surface and create a bounce in the wheels that would affect the accuracy of the weights. To achieve optimum accuracy, there are a number of factors that must

be taken into account including surface and road conditions. The capacitive mat WIM site should be located on a straight section of road of uniform horizontal and vertical alignment. Pavement conditions at the site should be reviewed for deflection, cracking, and roughness to ensure that the approach and exit surfaces are smooth. Areas where vehicles change speed should be avoided. Permanent screening lanes may have a surface of asphalt or concrete with special considerations given to surface conditions such as International Roughness Index (IRI), lane width recommendations, speed restrictions, rutting, cross fall, pavement thickness, flatness, and re-bar or steel reinforcement placement. These specifications may vary depending on suppliers. More information is provided at <http://www.ornl.gov/dp121/cm.htm>.

### **Piezoelectric, Quartz and Fiber-Optic Cables**

Piezoelectric materials convert mechanical stress or strain into proportionate electrical energy. Conversely, these materials mechanically expand or contract when voltages of opposite polarities are applied. Piezoelectric polymer films are also piezoelectric, converting heat into electrical charge. Piezoelectric polymer thin and thick films offer unique sensor design and performance advantages as they are flexible, robust, inert, and low cost. Bi-directional piezoelectric sensors may be used in conjunction with traffic counters/classifiers to detect the presence of an axle and a vehicle's direction. Therefore, they are capable of counting and classifying simultaneously for two separate lanes of traffic. Piezoelectric WIM systems are designed for permanent or temporary installation into or onto the road surface. The unique construction of the sensor allows it to be installed directly into the road in a flexible format so that it can conform to the profile of the road. The flat construction of the sensor gives an inherent rejection of road noise due to road bending, adjacent lanes, and bow waves for approaching vehicles. For permanent installations, the sensor is inserted into a small cut and secured in position with epoxy. The system provides both the high level of uniformity needed for weigh-in-motion applications and a cost-effective solution for applications for counting, classifying, speed detection, high-speed toll booths monitoring, and red light camera monitoring.

A Kistler or Quartz cable WIM system consists of a light metal profile in the middle of which quartz disks are fitted under preload. When the force is applied to the sensor surface, the quartz disks yield an electric charge proportional to the applied force. This charge is converted by an amplifier into a proportional voltage. Installation consists of making a small cut in the road into which the sensor is inserted. The sensor is then secured in the cut by a fast curing grout. Quartz systems have highly stable electrical and mechanical properties and their performance is negligibly influenced by temperature changes.

Recent advances in optical fiber sensors led to the development of a number of clever and compact fiber optic WIM systems. Optical fibers offer a number of advantages over the existing techniques in minimizing the effects of errors observed in the piezoelectric and quartz cables. Fiber optic systems are immune to electrical and magnetic interferences and are highly stable under dynamic loading conditions. Their stability

under dynamic loads stems from the fact that the transduction speed achieved by speed of light is much higher than the frequency of applied loads even under very high vehicle speeds. For this reason, a number of researchers began developing WIM technologies based on optical fibers. Muhs, et al., tested a fiber optic WIM system. His technique required separate calibration of the sensor for various vehicle speeds.<sup>(25)</sup> Ansari, et al. developed a fiber optic WIM sensor based on polarization properties of light.<sup>(26,27)</sup> His research involved testing of fiber cables subjected to dynamic loads and assessment of repeatability for various vehicle speeds. Malla, et al developed a prototype optical fiber sensor using a dual core optical fiber as the sensor.<sup>(28)</sup> Their system also indicated a high degree of load repeatability and accuracy of measurements under dynamic loads. Other types of fiber optic sensors, including an interferometric system are still under development.

As with the above-mentioned systems, to achieve optimum accuracy, a number of factors must be taken into account such as surface and road conditions. The piezoelectric/quartz WIM site should be located on a straight section of road of uniform horizontal and vertical alignment. Pavement conditions at the site should be reviewed for deflection, cracking, and roughness to ensure that the approach and exit surfaces are smooth enough to meet manufacturers specifications. Areas where vehicles change speed should be avoided. The site should also be easily accessible for electrical power and telephone services unless solar power or modems will be used. Permanent screening lanes may also have special considerations given to surface conditions such as International Roughness Index (IRI), lane width recommendations, speed restrictions, rutting, pavement thickness, flatness, and re-bar or steel reinforcement placement. These specifications may vary depending on suppliers. The website <http://www.ornl.gov/dp121/ps.htm> gives more detailed information on these systems.

### **Load Cells**

Load cell WIM systems are typically comprised of two weighing platforms per lane using from one single load cell per platform to as many as four load cells per platform. When pressure is exerted on load cells, the hydraulic pressure is measured and correlated to vehicle weight. Although configured differently, strain gauge load cells operate similarly to bending plate strain gauge systems in that the system records the strain (exerted by the rolling tires) measured by the strain gauge and calculates the dynamic load. Some load cell WIM systems utilize a single load cell with two scales to detect an axle and weigh both the right and left side of the axle simultaneously. As a vehicle passes over the load cell, the system records the weights measured by each scale and adds them together to obtain the axle weight. Typically, two platforms are mounted side by side in one lane of traffic, running perpendicular to the traffic flow. The platforms are placed in steel frames after the frames have been securely installed into the road with concrete. The benefit of this installation method is that the installation is not reliant on the structural integrity of the road pavement. The scale platforms are bolted to the scale frames and sit flush with the road surface so as not to be damaged by road maintenance such as sweeping or snow removal. The system is also completely sealed to prevent intrusion of water, salt, dirt, or other debris. Depending on the configuration,

the following types of data may be extracted from the system: wheel load, gross vehicle weight, date and time collected, site identification code, axle load, speed, axle-group load, center-to-center spacing, sequential vehicle record number, product codes, customer account, vehicle reports, and driver reports. Load cell WIM systems are typically installed in roadways, but can also be used in other applications such as on-board systems. The on-board systems are mounted to the vehicle and provide real-time weighing.

In order to achieve optimum accuracy, there are a number of factors that must be taken into account such as surface and road conditions. The load cell WIM site should be located on a straight section of road of uniform horizontal and vertical alignment. Pavement conditions at the site should be reviewed for deflection, cracking, and roughness to ensure that the approach and exit surfaces are smooth enough to meet manufacturers specifications. Areas where vehicles change speed, such as traffic control light should be avoided. The site should also be easily accessible for electrical power and telephone services unless solar power or modems will be used. Since this type of system requires a vault design, certain subgrade factors may need to be considered. Local authorities may need to be contacted regarding the subgrade conditions of the site. Permanent screening lanes may also have special considerations given to surface conditions such as International Roughness Index (IRI), lane width recommendations, speed restrictions, rutting, pavement thickness, flatness, and re-bar or steel reinforcement placement. These specifications may vary depending on suppliers. More information is provided at <http://www.ornl.gov/dp121/lc.ht.m>

### **Bridge WIM Systems**

Bridge Weigh-In-Motion (B-WIM) is the process by which axle and gross vehicle weights are automatically collected for trucks traveling at highway speeds over an instrumented bridge. B-WIM systems involve attaching strain transducers to bridge structural members and placing axle detectors on the bridge road surface. The axle detectors provide information on truck velocity, axle spacing, and the position of the truck. This information, along with the measured strains, is used by the bridge weigh-in-motion algorithm to determine axle and gross vehicle weights. Because the measurements are taken over the relatively long period during which the vehicle is passing over the structure, dynamic effects have less influence over the results than pavement systems that normally “sense” each truck axle weight over very short durations. This is especially true when B-WIM is used on bridges with relatively good riding surface conditions, or when used in culverts (as is the practice in Australia) where the soil provides additional damping.

Factors that affect the accuracy of B-WIM systems include length of bridge and bridge deck surface roughness that influences the dynamic effects. In this regard, shorter spans produce better results as they decrease the likelihood of interaction between the effects of several vehicles. Smoother surfaces reduce the dynamic effects resulting in more accurate evaluation of axle weights.

In addition to providing information on truck weights, headways and speeds, B-WIM systems collect information on the in-situ response of the instrumented bridge members

including impact factors, lateral distribution factors and strain records which are used for further bridge analysis. This information is an essential component of bridge health monitoring systems. When combined with information on structural member condition and deterioration rate this information provides the ingredients for accurate bridge rating and service life estimation.

The majority of B-WIM systems are used in the USA, Australia and South Korea. Several European countries are either using B-WIM systems or are in the process of implementing their use. These countries include Sweden, France, Ireland, Slovenia, Austria, and Hungary. Work is currently underway to develop a B-WIM system that does not require axle detectors on the bridge surface. This would improve the durability of the system and reduce installation cost and safety as the installation of the improved system would not affect traffic on the bridge and make the system completely undetectable.

### **WIM System Selection and Accuracy**

To help an agency choose a WIM system from the myriad of possibilities, the ORNL website has categorized WIM systems in four different ways based on the type of application, the technology, traffic speed and portability. The site compares the systems used in the U.S. based on the type of applications, the technology used, the speed of traffic, and system portability. The site does not consider B-WIM systems and from the three different cable systems discussed above, only piezoelectric systems are included. Bridge rating and safety assessment applications are not discussed either. A summary of the ORNL findings on the accuracy of the four systems that they reviewed is presented in Table C2. These results are somewhat similar to those provided on the Iowa State Web page. Similar information on B-WIM system and the Quartz system is provided in the last two rows of the table based on information assembled in Europe as provided by ZAG and publications provided by the AARB Transport Research group in Australia.

It should be noted, however, that for the full potential accuracy of the above listed pavement type systems to be achieved, the pavement conditions at and around the site must be perfectly smooth with no ruts or cracks. Such conditions were found to be very difficult to achieve without an extensive and continuous pavement rehabilitation program. Continuous pavement rehabilitation renders the life cycle costs of pavement systems rather expensive. In order to maintain the level of accuracy shown in Table C2, European investigators, as reported by the ZAG web page, have found that pavement type systems should be installed in arrays of ten systems so that the errors would be averaged out and accurate data obtained. This arrangement would increase the costs of installation. However, B-WIM systems do not require such extensive pavement rehabilitation programs and would provide more reliable results over longer periods of time.

A life cycle cost analysis performed as part of the Iowa state study shows that, on the average, the annual cost associated with maintaining a pavement-based system would be on the order of \$21,000 with a breakdown shown in Table C3. B-WIM costs would

be expected to require no special pavement or site maintenance costs, thus reducing the total annual costs by up to 23%.

**Table C2: Summary of WIM System Accuracy**

<b>TECHNOLOGY</b>	<b>ACCURACY</b>
<a href="#">Bending Plate</a>	0 to 12%
<a href="#">Capacitive Mat</a>	0.5 to 1.5%
<a href="#">Load Cell</a>	0 to 6%
<a href="#">Piezoelectric</a>	3 to 30%
<b><u>Quartz cables</u></b>	<10%
<b><u>B-WIM</u></b>	0 to 3%

**Table C3: Estimated Average Annual Cost of Maintaining a Pavement-Based WIM System**

Pavement rehabilitation	\$2,280
Other site maintenance	\$2,500
Sensor replacement	\$825
Electronics replacement	\$750
Calibration costs	\$11,000
Office costs	\$1,150
Travel and per diem	\$2,500
Total annual costs	\$21,000

Estimated initial costs for four specific pavement-based WIM systems are also provided on the Iowa State web page. These are summarized in Table C4. The cost of a Bridge WIM system per lane is estimated to be on the order of \$14,500. However, all pavement-based systems would require a rehabilitation of the pavement in the area before and around the installation, which is not required for B-WIM. If an array of ten cable or plate systems is needed, then the initial costs will become extremely high.

**Table C4: Estimated Initial Cost per Lane for Pavement-Based WIM Systems**

Piezoelectric sensor	\$9,500
Bending Plate	\$18,900
Load cell	\$52,500
B-WIM	\$14,500

In reviewing WIM technology, it is to be noted that the AASHTO Guide for Condition Evaluation and LRFR of Highway Bridges<sup>(29)</sup> allows for the use of field data and site-specific load information to determine the load carrying capacity of a bridge and determine its safe life for both fatigue and strength. The manual permits the use of measured data on load distribution and the dynamic structural response to model the true behavior of the bridge rather than rely on analytical approaches. Because the uncertainty associated with the live loads is generally the greatest, the manual suggests that the determination of the live load model used for rating be a candidate for closer scrutiny. During the design of new bridges, conservative load factors are assigned to encompass all likely site-to-site variations in maximum loads. For existing bridge evaluation, much of the implicit conservatism could be eliminated by obtaining site-specific information. The reduction in the uncertainty could result in reduced load factors. If site investigation shows greater overloads, the load factor must be increased. The smart-bridge collection of vehicle weight and truck traffic data is therefore needed to verify long-term safety. Ghosn et al. have demonstrated how this information can be used to perform the load capacity evaluation of bridges using site-specific information on bridge loads and bridge response, and load distribution.<sup>(30)</sup> Although the original concepts were developed in the U.S. the above-mentioned approach for bridge evaluation has been most widely accepted and implemented in Europe, as described on the ZAG web page. It is expected that the recent adoption by AASHTO of the LRFR manual would open the door for wider implementation in the U.S.

**Application of WIM Technology & Smart Bridges to Bridge Rating**

The purpose of implementing smart bridge technology is to collect information on the live loads applied on bridge structures and the response of these structures to the applied live loads in order to ascertain the structures' safety levels and estimate their remaining safe lives. The coupling of WIM technology (particularly B-WIM technology) with corrosion deterioration sensors and other deflection and strain monitoring devices will provide an important set of tools that will provide the data to perform an accurate in-situ evaluation of the behavior of an instrumented bridge and obtain estimated projections of its safe life. The information provided by smart bridges is classified into three categories:



- Information related to truck loads as provided by any WIM system;
- Information related to the bridge's response under actual truck crossings as provided by a B-WIM system, coupled with other strain and deflection measuring devices; and
- Information related to member deterioration as provided by corrosion detection sensors and strain processing algorithms that would monitor changes in the response of a bridge.

This information can be included in the bridge rating process as described by the AASHTO Manual for condition evaluation and load and resistance factor rating (LRFR) of highway bridges. The AASHTO LRFR procedure has been developed to utilize information on the in-situ loading and response of a bridge using traditional technology. Updated rating procedures can be developed in the future to take advantage of new sensor technology such as the corrosion detection sensors and deflection and strain monitoring devices listed in separate parts of this document. Below is a short discussion of these issues.

### **AASHTO Load Rating (LRFR) Procedures**

The new AASHTO LRFR manual stipulates three levels of load rating procedures that are listed as: a) Design load rating (level I); b) Legal load rating (Level II); and c) Permit load rating (Level III). Each procedure is geared toward a specific live load model with different load factors. A rating factor less than 1.0 indicates that the bridge member under investigation does not provide adequate safety levels, which would trigger a set of actions and refined analyses. The rating factor is defined as:

$$RF = \frac{C - \gamma_{DC} DC - \gamma_{DW} DW}{\gamma_{LL} (LL + IM)} \dots\dots\dots (C-6)$$

where: RF = rating factor

C = factored member capacity

DC = dead load effect of components

DW = dead load effect of wearing surface and utilities

LL = live load effect

IM = dynamic load allowance

$\gamma_{DC}$  = dead load factor for components

$\gamma_{DW}$  = dead load factor for wearing surface and utilities

$\gamma_{LL}$  = live load factor

The factored member capacity is given as:

$$C = \Phi_c \Phi_s \Phi R_n \dots\dots\dots (C-7)$$

where:  $R_n$  = nominal member resistance as-inspected

$\Phi$  = LRFD resistance factor as provided in AASHTO bridge specifications

$\Phi_s$  = system factor that reflects the redundancy and ductility of the system  
 $\Phi_c$  = condition factor

The member resistance factor,  $\Phi$ , depends on the type of member. The system factor  $\Phi_s$  varies between 0.85 and 1.0 depending on the member and bridge type as well as the number and spacing between parallel girders in girder bridges. The condition factor accounts for the uncertainty associated with estimating the resistance of a member once it begins to degrade and deteriorate. It is given as  $\Phi_c = 1.0$  for good and satisfactory members if the inspection condition rating is 6 or higher, 0.95 for members in fair condition (condition rating=5) and 0.85 for members in poor condition (condition rating less than or equal to 4).

To take advantage of WIM technology, the AASHTO LRFR permits the inclusion of data collected by WIM systems for the determination of the live load factor. Several options are provided for calculating  $\gamma_{LL}$ , the most general equation for two lanes of traffic being:

$$\gamma_{LL} = 1.8 \left[ \frac{2W^* + t_{ADTT} 1.41\sigma^*}{240} \right] > 1.30 \quad \dots\dots\dots(C-8)$$

where:  $W^*$  = the mean truck weight for the top 20% of the truck weight sample that can be obtained from WIM

$\sigma^*$  = the standard deviation of the top 20% of truck weights and

$t_{ADTT}$  = fractile value from normal distribution tables given in terms of the average daily truck traffic ADTT

In addition to including information from WIM systems about the truck weight statistics ( $W^*$ ) and its standard deviation ( $\sigma^*$ ), as well as the truck traffic rate (ADTT), the AASHTO LRFR allows for using different impact allowances (IM) and allows for the determination of the load distribution factor (g) from in situ information about the roughness of the riding surface and measurements of strains.

## **IMPLEMENTATION OF SMART BRIDGE RESPONSE DATA IN BRIDGE LOAD RATING PROCESS**

### **Bridge Loads and Behavior**

In section 8 of the AASHTO LRFR Manual, general statements are made as to the possibility and the benefits of using load tests to study the behavior of a bridge structure in order to refine the analytical models that are typically used. These load tests would provide information on unintended composite action, unintended continuity and fixity, participation of secondary members in enhancing the stiffness and the load carrying capacity of the bridge, participation of non-structural members, and the contribution of the deck. The benefits of load tests as listed in the Manual include: the load rating of

bridges with unknown component properties (such as historic bridges with no plans); determination of distribution of live load to main load-carrying members; studying the effect of deterioration on the behavior of the bridge; evaluation of fatigue life based on measured stresses (including distortion-induced stresses); and determination of the dynamic allowance. This information can be either directly incorporated in the bridge load rating process or can be utilized to improve the analytical models used for the structural analysis of the bridge.

B-WIM systems and smart bridges instrumented with the new sensors mentioned in other parts of this document can provide all the information required to produce load ratings based on field measurements. In fact, the AASHTO LRFR Manual even permits the use of WIM data to develop specialized live load models other than those provided in the manual. Furthermore, section 9.2 of the Manual allows for the use of a “direct” safety assessment method for bridges based on reliability indices. A procedure describing how this reliability analysis may be performed from B-WIM data is described in the paper by Ghosn, Moses and Gobieski.<sup>(30)</sup>

Information collected on the response of the bridge to known vehicular loads can be utilized to adjust the models used to analyze the particular bridge under investigation. For example, from measured strains and rotations at end supports, the boundary conditions of the model can be adjusted to account for the presence of unintended end restraints and fixities. By observing the strain at two locations along the depth of a member, the location of the neutral axis can be determined and the presence of unintended composite action accounted for. Other factors that can be obtained include the impact allowance factor and the girder distribution factors for parallel girders.

### **Member Capacity**

Increase in deflections in the structural stiffness of a bridge member and change in the reactions and load distribution of the structure, can be detected by properly instrumented smart bridges and their effects may be directly included in the load rating process or in the structural analysis models that can be modified based on comparison with the measured bridge response. Corrosion monitoring devices will help provide estimates on the expected losses in member capacity over the design life of the bridge. Future generations of LRFR specifications need to develop methods to include such information into the load rating process. The procedures must be carefully developed to account for the uncertainties associated with utilizing the field information in a manner consistent with the latest development in the field of structural reliability.

## **CONCLUSION AND RECOMMENDATIONS**

An overview of most frequent nondestructive corrosion determination methods, as applied to reinforced concrete bridges, is presented. Nondestructive methods are advantageous when compared to destructive methods. Continuous monitoring of reinforcement condition is enabled, measurements can be done at the level of the entire

structure, and nondestructive methods have proven to be fast and inexpensive. On the other hand, determination of reinforcement steel corrosion with nondestructive methods is complex and may lead to wrong interpretation of results. To avoid misinterpretation it is recommended to combine several nondestructive testing methods, before making any conclusion about reinforcement steel corrosion. It is also recommended that WIM technology be deployed in tandem with the sensor technologies, to improve upon the state-of-the-art methodology for bridge rating.

## REFERENCES

1. Devalapura, R.K.; Kamel, M.R.; Arumugasaamy, P., *Nondestructive Techniques for Corrosion Evaluation of Steel in Concrete, Corrosion and Corrosion Protection of Steel in Concrete*, Proceedings of International Conference held at the University of Sheffield, Vol.1, July 1994, pp.300-309.
2. Moller, P.H., *Potential Mapping - an Important Method of Measuring R.C. Structures, Construction Maintenance & Repair*, June 1992, pp. 21-23.
3. Broomfield, J.P., Langford P.E., Ewins, A.J., *The Use of Potential Wheel to Survey Reinforced Concrete Structures, Corrosion Rates of Steel in Concrete*, ASTM STP 1065, N.S. Berke, V., Chaker, D. Whiting, EDS, American Society for Testing and Materials, Philadelphia, 1990, pp.157-173.
4. <http://www.cescor.it>
5. <http://www.germann.org>
6. <http://www.a-bau.co.at>
7. Bjegovic D., Miksic, B., Stehly R., *Test Protocols for Migrating Corrosion Inhibitors (MCI) in Reinforced Concrete*, Emerging Trends in Corrosion Control - Evaluation, Monitoring, Solutions, Vol. 1, Akademia Books International and NACE International, India Section, New Delhi, India, 1999, pp. 3-18.
8. Schiessl, P., Raupach, M., *Monitoring System for the Corrosion Risk of Steel in Concrete Structures*, Concrete International, 1992, No.7, pp. 52-55.
9. Katwan M.J., Hodgkiess T.; Arthur P.D., *Electrochemical Noise Technique for the Prediction of Corrosion Rate of Steel in Concrete Materials and Structures*, Vol.29, June 1996, pp. 286-294.
10. Bjegovic, D., *Elektrokemijski aspekti korozije armiranog betona*, Gradevinar, Vol.51, No.7, 1994, pp.405-415.
11. Broomfield, J.P., Rodriguez, J., Ortega, L.M., Garcia, A.M., *Corrosion Rate and Life Prediction for Reinforced Concrete Structures*, GEOCISA Spain, Structural Faults and Repairs Symposium, June 1993.
12. <http://corrpro.com>
13. Nagayama, M., *MCI 2020 Long Term Test Protection of Rebar in Concrete, Final Report*, General Building Research Corporation of Japan, October 1999.

14. Lemoine, L., Wenger F., Galland J., *Study of the Corrosion of Concrete Reinforcement by Electrochemical Impedance Measurement*, Corrosion Rates of Steel in Concrete, ASTM STP 1065, N.S. Berke, V. Chaker, and D. Whiting, Eds., American Society for Testing and Materials, Philadelphia, 1990, pp. 118-133.
15. Morlidge, J.R., *Electrochemical Techniques for the Detection of Concrete Corrosion Inhibitors under Simulated Pore Solution Conditions*, Aston University One Day Conference, Wednesday 26 January 2000.
16. Elsener, B., Wojtas H., Bohni H., *Galvanostatic Pulse Measurements - Rapid on Site Corrosion Monitoring*, Proceedings of International Conference held at the University of Sheffield, Vol.1, 24 - 28 July 1994, pp. 236-246.
17. Akid R., *Application of the Scanning Reference Electrode Technique to the Study of Steel Corrosion in a Cement-based Coating*, Conference held at the University of Sheffield, Vol.1, 24 - 28 July 1994, pp. 278 - 289.
18. Broomfield, J.P., *Assessing Corrosion Damage on Reinforced Concrete Structures*, Proceedings of International Conference held at the University of Sheffield, Vol.1, 24-28 July, 1994, pp. 1-25.
19. Chase, S.B., Livingston, R., Washer, G., *Nondestructive Evaluation (NDE) of Highway Bridges*, <http://www.tfsrc.gov/structur/struc98/ch5.htm>, 1998.
20. <http://www.ndt.net/article/wcndt00/papers/idn642/idn642.htm>
21. Ghorbanpoor, A., Shi, S., *Assessment of Corrosion of Steel in Concrete Structures by Magnetic based NDE Techniques*, Techniques to Assess the Corrosion Activity of Steel Reinforced Concrete Structures, ASTM STP 1276, Neal S. Berke, Edward Escalante, Charles K. Nmai, and David Whiting, EDS. American Society for Testing and Materials, 1996.
22. Gucunski N., Maher, A., *Use of Nondestructive Seismic Techniques for Optimum Maintenance and Management of Roads and Bridges*, Proceedings, Second Croatian Road Congress, 24-27 October 1999, Vol. 1, pp. 211-218.
23. <http://www.tfsrc.gov/structur/struc98/ch5.htm>
24. McCall & Vodrazka (1997) (State's Successful Practices in Weigh-In-Motion Handbook, McCall, B. and Vodrazka, W.C. Jr. Center for Transportation Research & Education, Ames, Iowa, Dec. 1997).
25. Muhs, J.D., Tobin, K.W., and Jordan, J.K., "Fiber Optic Sensors for Transportation Applications," A Novel Method of In-Motion Vehicle Monitoring," 7<sup>th</sup> Optical fiber Sensors Conference, The Institution of Radio and Electronics Engineers, Sydney, Australia, December 1990
26. Ansari, F., Wang, J., "Fiber Optic Polarimetric Dynamic Force Sensor", Experimental Techniques (SEM), V. 20, No 1., January/February 1996, PP. 20-23.
27. Ansari, F., and Wang, J., "Rate Sensitivity of High Birefringent Fiber Optic Sensors Under Large Dynamic Loads," IEEE, J. of Light-wave Technology., Vol. 13, No. 10, October 1995, PP. 1992-97.

28. Malla, R.B., Garrick, N.W., "Dual Core FTDM Fiber Optic WIM System," Final Report, NCHRP-IDEA, Project 42, November, 2000
29. AASHTO Manual for Condition Evaluation and Load and Resistance Factor Rating of Highway Bridges, A.G. Lichtenstein & Associates, March 2000.
30. Ghosn, M., F. Moses and J. Gobieski, "Evaluation of Steel Bridges Using In-Service Testing", Transportation Research Records, TRR 1072, Dec. 1986.
31. ACI Committee Report 224.4R, "Causes, Evaluation and Repair of Cracks in Concrete Structures", American Concrete Institute, 1993.

## APPENDIX C: SENSOR EQUIPMENT

### Appendix C1: Embedded Sensors

#### Appendix C1.1: Standard Reference Half-Cell by Cescor – Embeddable in Concrete

**Company:** Cescor, Italy

**Source:** <http://www.cescor.it>

#### ***Construction of the Probe***

This is permanent embeddable pseudo-reference electrode for corrosion monitoring in reinforced concrete structures that has been developed by Cescor. It consists of a LIDA mixed metal oxide (MMO) activated titanium rod, cast in a specially developed cementitious body contained in a plastic insulating cylinder. Electrical contact with the surrounding concrete is assured by a cementitious plug. The cementitious backfill provides constant pH around the activated titanium sensor and long-term stability of the electrochemical potential. The low porosity characteristics of cementitious plug avoids environmental changes of the bulk. A schematic figure of the reference electrode is shown in Figure C16.

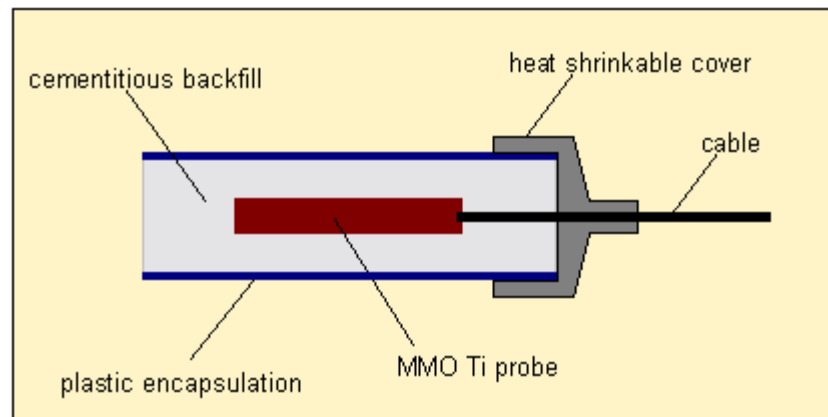

**Figure C16. Schematic of the Pseudo-Reference Electrode Produced by Cescor**

Several years of testing confirmed long-term stability and reproducibility. Contamination with chloride ions does not affect, for practical purposes, the potential value and potential stability.

#### ***Potential Uses***

- Corrosion monitoring
- Monitoring of stray current interference

- Cathodic protection control and regulation

**Advantages offered by this embedded pseudo-reference electrode:**

- Stable potential
- Rugged and mechanically resistant
- Absence of gel backfills and porous ceramic plugs - eliminates drying out problems and loose of electrical contact with the surrounding concrete
- Electrical potential calibrated - each probe is calibrated in limewater before shipment

**Specifications**

<b>SPECIFICATIONS</b>	
<b>Potential</b>	- 80 ± 20 mV Vs. Saturated Calomel Electrode - 135 ± 20 mV Vs. Cu/CuSO <sub>4,sat</sub> These are typical values, at time of delivery, measured after half an hour soaking in saturated Ca(OH) <sub>2</sub> at 25C°
<b>Potential in concrete average</b>	+50 ± 20 mV Vs. SCE. These values are based on a statistical analysis of 5 years of potential reading versus SCE of electrodes embedded in concrete blocks exposed to external environmental conditions. The measurements have been carried out by placing the SCE in a hole drilled very close to the activated titanium electrode location. Note: the difference between the values measured in limewater and concrete are due to junction potentials, which develop when the concrete body is put into liquid solutions.
<b>Connecting Cable</b>	1,5 metres of Cu/PVC 2,5 mm <sup>2</sup> (AWG 13) cable. Colour: black.
<b>Temperature range</b>	based on actual experience, satisfactory performance from 2 to 40 C°.
<b>Life expectancy</b>	no limitations after 5 years of testing.
<b>Measuring Instrument</b>	high input impedance Voltmeters (> 1 GIGAOHM) should be used to carry out measurements.



### ***Monitoring System for Reinforced and Prestressed Concrete Structures (supplied with transformer rectifier)***

- Automatic control and regulation transformer/rectifiers for reinforced concrete
- Local and remote alarm on programmed thresholds
- Possibility of local reading of reference electrode
- Programmable from portable computer
- Simultaneous control of 4 signals

It controls operating parameters by means of:

- Potentials measurement and comparison with thresholds
- 100 mv decay depolarization test (4 hours or more)
- Regulation of T/R output in voltage and current
- Frequency of measurements and control parameters are software programmable

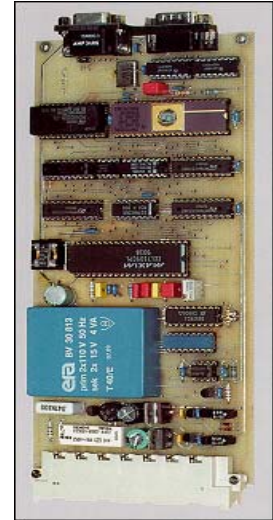

### ***Transformer-Rectifier for Reinforced and Prestressed Concrete Structures***

- T/R switching output 10V-10A max input 220V50 Hz
- Very high efficiency (90%) minimum ripple
- Local and remote control
- Minimum dimensions: weight 2 Kg
- Remote isolated control from the T/R output and AC network
- Possibility of series/parallel connecting
- For cathodic protection systems for reinforced and prestressed concrete structures with distributed anodes
- High regulation sensitivity with constant current and voltage
- Single or rack type in two or more panel units Suitable with the local monitoring system

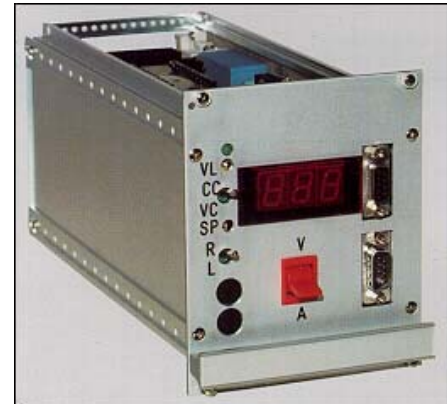

## **Appendix C1.2: Embedded Reference Half-Cell -- ERE 20 Probes**

**Company:** Force Technology (Norway) – Product marketed in the US by Germann Instruments

**Source:** <http://www.germann.org>

The ERE-probe is an embeddable reference electrode for long term monitoring of the corrosion condition of reinforcement. Attached to the reinforcement, the ERE probe is cast into the fresh concrete. Alternatively, it may be cast into a hole drilled into an existing structure.

### ***Construction of the Probe***

The probe contains a manganese dioxide electrode in a corrosion resistant steel housing with an alkaline, chloride-free gel. The front of the probe has a porous plug made of fiber cement. Except for the plug, the unit is sealed in a rubber tube. The porous plug will be in intimate contact with the concrete. The pH of the gel corresponds to that of porewater in a normal concrete, so that errors due to diffusion of ions through the porous plugs are eliminated. A photograph of embedded reference electrode attached to steel reinforcement is shown in Figure C17

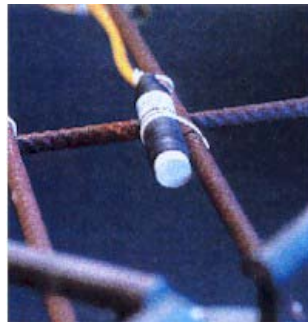

**Figure C17. Photograph of the Embedded Reference Electrode Produced by ERE**

### ***Uses of the Probe***

- long term monitoring of the corrosion condition of reinforcement
- control and adjustment of cathodic protection levels
- calibration of surface potential measurements when using an external reference electrode such as the Ag/AgCl electrodes.

### ***Specifications***

- The typical potential value measured in saturated  $\text{Ca(OH)}_2$  at 23°C is +160 mV versus saturated calomel electrode (SCE) equal to +405 mV on the hydrogen scale. Each single probe's potential is never lower than +140 mV versus SCE and never higher than +180 mV versus SCE.
- The potential shift of a single electrode at a constant temperature and electrolyte environment will not exceed +/- 5 mV compared to the initially measured value.

- During frost periods false readings must be expected. After thawing, however, normal properties are regained. High temperature (>40°C) may affect the probe as well. A long period (several years) of extreme dryness may eventually destroy the probe by desiccation.

### **ERE-20 Reference Electrode and Datalogger by Protector Group (Norway)**

Source: <http://www.protector-group.no>

#### ***Use and Information Provided***

This reputable reference electrode is providing unique properties for monitoring electrochemical potentials in concrete. As a true half cell, ERE 20 provides long time stability as well as independence of changes in the chemical properties of the concrete. The ERE 20 is a true, long life Reference Electrode which can be embedded in concrete and used to control the cathodic protection and to monitor the corrosion potential of reinforcing steel. The potential of ERE 20 is nearly independent of changes in the chemical properties of the concrete. It can, therefore, be used in wet or dry concrete, whether exposed to chloride or carbonation.

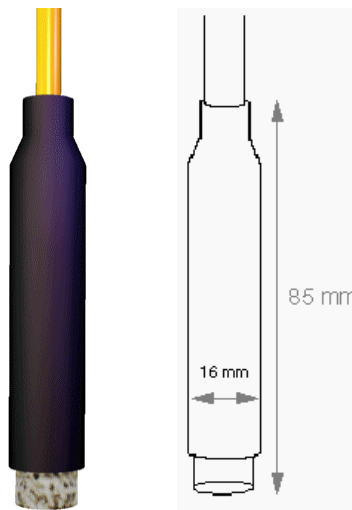

#### ***Construction of the Probe***

Based on proven battery technology, the ERE 20 is a true half-cell using a manganese dioxide electrode in a steel housing with an alkaline, chloride-free gel. The steel housing is made from a more corrosion resistant material than the nickel plated steel of ERE 10. The pH of the gel corresponds to that of porewater in a normal concrete, so errors due to diffusion of ions through the pores are eliminated.

The porous plug is made of a cement-based material with fibre reinforcement and is shaped in such a way that it will have intimate contact with the concrete in which it is placed. Introduction of fibre reinforcement remarkably improves the mechanical strength of the plug. If desired, it can be placed in close contact with the steel reinforcement. It will not induce corrosion or change the potential of steel in close proximity

### **Specifications**

Typical potential value measured in saturated  $\text{Ca}(\text{OH})_2$  at 23°C is +160mV Vs saturated calomel electrode (SCE) equal to +405mV hydrogen scale. The potential of a single electrode is never lower than +140 mV Vs SCE and electrolyte environment will not exceed 5 mV compared with the initially measured potential value.

Note: these are typical values measured in saturated  $\text{Ca}(\text{OH})_2$  at 23°C at time of delivery. The potential of the ERE 20 Reference Electrode is checked prior to shipment and the measured potential vs. saturated calomel electrode is supplied with each electrode. The internal resistance is less than 5000 Ohm after soaking in water. Connecting cable: 5 metres single core, standard copper conductor (8 strands, 3,1mm<sup>2</sup>) with XLPE insulation and PVC sheathing. During frost periods, false readings must be expected. After thawing, normal properties are regained. High temperature limitations are not known at the time of writing. Prolonged periods (several years) of extreme dryness may eventually destroy the cells by desiccation. In the investigated range from -10°C to +40°C performance is satisfactory.

The electrode life is not limited because the half-cell is in chemical equilibrium with the surrounding environment. Furthermore, the manganese oxide exists as a natural mineral in the crust of the earth will be stable for a long-range period. The lifetime is governed by the amount of cell electrolyte which has been set for several years of service.

The ERE 20 is in use in **Camur Chloride sensors** as well as in **Camur CorrRate sensors**.

**Camur CorrRate Sensor for Corrosion Rate Measurement based on ERE –20 (by Protector Group Norway)**

Source: <http://www.protector-group.no>

### **Construction**

The sensor is permanently mounted to the concrete and enables monitoring of long-time corrosion rate trends. The datalogger **Camur** and the sensor **CorrRate** measures the real corrosion rate on your reinforcement. The Camur datalogger is developed specifically for monitoring of electrochemical parameters in concrete. With its high input impedance the reference cells can be measured directly, and its built in functionality includes procedures to verify the efficiency of cathodic protection installations (automatic depolarisation measurements). The Camur doubles as both a portable instrument and a datalogger for permanent installation.



Height:	33 cm
Width:	16 cm
Depth:	6 cm

**Accessories & options:**

- Available with 8, 16 or 24 channels. Standard input range  $\pm 5V$ .
- Versions with & without outputs for remote control.
- Industry standard interface for modem connection.

**Uses**

- determine whether the reinforcement in concrete is corroding
- determine if the expensive maintenance work working as expected

**Installation**

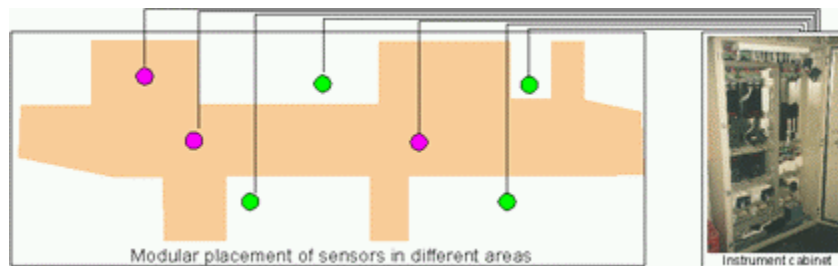

**Figure C18. Installation of Camur CorrRate Sensors**

Camur produces electro-chemical measurement values (corrosion rate, potentials, resistance, chlorides, pH, temperature, RH etc.) obtained through selected sensors and daily measurements. The collected data is computer analysed, registered and forms the basis for a pre-treatment verified condition, which is a part of the project management plan and the six-year service warranty provided by PROTECTOR AS. The installation and pre-treatment analysis can typically take four weeks, but is project dependent.

### **Appendix C1.3: Embeddable pH Sensor by Protector Group, Norway**

**Company:** Protector Group (Norway)

**Source:** <http://www.protector-group.no>

#### ***Description***

The alkalinity of the concrete is an important deciding factor for corrosion. This parameter is influenced both unintentionally through pollution, and intentionally through electrochemical repair techniques.



Through permanent installation of the pH sensor, it is possible to evaluate the trends of these slow processes, as well as evaluating the efficiency of electrochemical repairs.

Total Length of this sensor = 30mm

## **Appendix C1.4: Embeddable Sensor for MacroCell Measurements and Data Logger**

**Company:** Force Technologies (Denmark)

**Source:** <http://www.force.dk/ciad>

### ***Macro-Cell Measurements***

The corrosion rate of the reinforcement can be monitored continuously by using macrocell current measurements between anodically and cathodically acting steel surface areas. In principle, a macrocell consists of a piece of black steel (anode) and a noble metal (cathode). In chloride-free and non-carbonated concrete, both anode and cathode are protected against corrosion due to alkalinity of the pore water of the concrete and the electrical current between the electrodes is negligibly low (passive state).

However, if the critical chloride concentration is reached, or if the pH value of the concrete decreases due to carbonation, the steel surface of the anode is no longer protected against corrosion. As long as the cathode material is corrosion resistant in chloride contaminated or carbonated concrete and sufficient moisture and oxygen are available, the oxygen reduction takes here place (cathode reaction). This separation of local anode and cathode areas leads to flow of the electrical current (corrosion current) between the anode and cathode. A rapid increase of this current indicates the breakdown of passivity and initiation of corrosion.

This principle has been used for construction of macrocells which were applied for monitoring of depassivation front in new structures as well as in existing structures

### ***Embeddable Corrowatch***

With anodes placed in at least three different depths from the concrete surface it will be possible to estimate the ingress of chloride through the concrete and the expected time to initiation of reinforcement corrosion. This will make it possible to conduct a very effective planning of maintenance strategy.

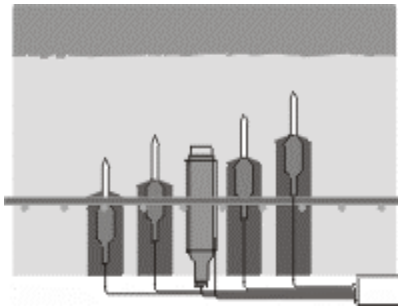

**Figure C19. Embeddable Corrowatch – Macro-Cell for Registering the Initiation of Corrosion**



### ***Post Mounted CorroWatch***

This probe consists of 8 mild steel nails (anodes) placed symmetrically in a 12 cm circle with a titanium cathode and MnO<sub>2</sub> reference electrode in the middle. The nails are installed in pairs into the defined depth of existing concrete by means of a specially constructed device. By means of the electrical conductivity measurements, it has been proved that the nails have an excellent contact with the existing concrete. Thereby, four pairs of nails are exposed at four different depths in the existing concrete and will monitor the corrosion current, which rise indicates time to corrosion initiation.



(a)

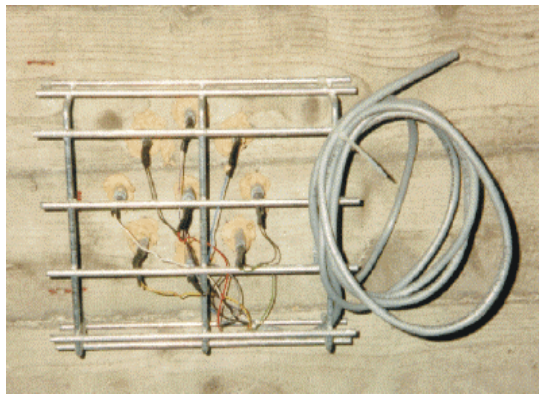

(b)

(a) Sketch of CorroWatch showing ingress of the depassivation front  
(b) Post mounted CorroWatch in concrete wall

**Figure C20. Embedded CorroWatch**

### ***Applications***

The CorroWatch is typically used for tunnels, which are difficult to access for inspection, bridges in maritime environments where the effects of salt water can be significant, as well as parking decks, and other structures, which are affected by de-icing salts.

### **CorroLog -- 8-Channel Mini Data logger**

#### ***General Description***

This miniature light-weight data logger is developed especially for collecting and monitoring low-potential-values e.g. from CorroWatch probes. Because of the small size, the low power consumption and the waterproof rating, the data logger is highly recommended for use in outdoor environments at inaccessible places nearby the monitoring system.



**Figure C21. Corrolog Datalogger**

***Technical Description***

The data logger has a high degree of data security while the memory (EPROM) will keep all readings even at low battery. The 8-channel data logger can collect data from two CorroWatch probes at the same time. The data logger is based on a well-known 1-channel data logger from Orion Group UK. It stores up to 7900 data readings, along with related information such as time interval, real time and description. The time interval can be specified either in seconds or minutes and the range can vary from seconds up to 10 days. It is possible to make up to 45 days of time delay.

***Software***

The Windows based software program is extremely user-friendly and flexible. With manageable commands the intervals and delay for readings are managed. Data transfer is easy and fast, and all data can be presented either in graphic mode or by values. Even a data range of special interest can be selected quickly, and viewed. Also the opportunity of assembling data from other data loggers is possible.

Basic technical data.
Size: 75*50*33 mm Weight: 300 g Rating: yellow glass fibre PE rating Channels: 8 channels for reading, 1 control channel Cable: multicable, screened PVC, 10 cores. Range: $\pm 1$ V Input impedance: higher than 10 K Ohms Temperature range: -40° C to 75° C Battery: 3.6V ½ AA size Lithium Battery Life: 1¼ year

### ***Reference Material***

- Title** Monitoring of reinforcement corrosion by means of embedded sensors and portable polarization technique.
- Authors** Oskar Klinghoffer, Thomas Frølund, Brian Kofoed
- Conference** International conference: Corrosion and Rehabilitation of Reinforced Concrete Structures. Orlando, December 1998

## **Appendix C1.5: Embedded Reference Half-Cell -- Corrosometer 650C Concrete Probe and CK-3 Datalogger**

**Company: Corrpro Companies Inc.**

**Source: <http://www.corrpro.com>**

### ***General Principle***

The Rohrback Cosasco Systems (RCS) Model 650C CORROSOMETER® Concrete Probe is used to measure the corrosion rate of steel reinforced concrete structures. The CORROSOMETER® systems measure cumulative metal loss without removal from the corrosive environment. Metal loss from corrosion or erosion is determined from the increase in electrical resistance of the metal element (wire, tube or strip) exposed to the environment. Monitoring instruments convert the resistance change into metal loss and corrosion rate readings

### ***Construction and Working of the Probe***

The 650C CORROSOMETER® Concrete Probe consists of a thin tubular steel element similar in size to a small rebar in contact with the concrete. The steel element will corrode if conditions necessary for corrosion are present. As the probe element corrodes, its thickness decreases, and its electrical resistance increases. The metal loss is computed by measuring the increase in resistance.



**Figure C22. Photograph of the 650C Corrosometer Concrete Probe**

The 650C CORROSOMETER® Concrete Probe measures cumulative metal loss, so that any corrosion problems that have occurred between probe measurements will not be lost. By positioning probes in critical areas just above the rebar, the increasing corrosion rate due to penetration of chlorides may be detected before the rebar

corrodes. This allows preventive measures to be taken in a timely manner before the onset of corrosion.

To prevent deterioration of steel reinforced concrete structures, various types of corrosion protection systems have been employed. These include high-performance concrete, corrosion inhibitors, sealers, waterproof membranes, and cathodic protection. The use of stainless steel and galvanized steel rebar has also been used on a limited basis. The 650C CORROSOMETER® Concrete Probe provides a means of evaluating the effectiveness of these systems.

The portable instrument (CK-3) can be used to show the rate of corrosion and the amount of steel loss due to corrosion.

### **CK-3/CK-4 Datalogger**

A portable, economical instrument for on-site monitoring of CORROSOMETER® probes, which displays metal loss.

### ***CK-3 Model***



**Figure C23. CK-3 Model**

The CK-3 is a measure metal loss and provides a low capital cost corrosion monitoring solution where continuous measurement is not essential for corrosion management. The Rohrback Cosasco Systems (RCS) Model CK-3 CORROSOMETER® Instrument is used for monitoring of CORROSOMETER® probes. The CK-3 is used to take readings from CORROSOMETER® probes, which enables metal loss against time to be monitored. This data allows corrosion rates to be determined without removing the corrosion probe. Without a system (corrosion probes and instruments) such as this in

use, you would have to shut down your process and internally inspect the equipment, or cut out a section and look at it to determine the corrosion rate, either of which are very expensive and time-consuming propositions.

#### ***CK-4 Model***

The Rohrback Cosasco Systems (RCS) Model CK-4 CORROSOMETER® Instrument is a multi-parameter corrosion monitor designed to read both corrosion metal loss and temperature. The CK-4 stores readings from probes for subsequent retrieval so the operator does not have to carry around pencil and paper for manual recording. The CK-4 can even calculate corrosion rates from the last reading if there has been enough time between readings



**Figure C24. CK-4 Model**

## **Appendix C1.6: An Embedded Linear Polarization Resistance Probe - Model 800/800T Corratr Concrete Probe**

**Company:** *Corrpro Companies Inc.*

**Source:** <http://www.corrpro.com>

### ***Operating Principle***

The Rohrback Cosasco Systems (RCS) Model 800/800T CORRATER® Concrete Probe measures the instantaneous corrosion rate of reinforcing steel in concrete by the method of Linear Polarization Resistance (LPR).

### ***Construction of Probe***

The electrodes of the LPR probe are manufactured using carbon steel. Each reading gives the instantaneous corrosion rate of the electrodes in the concrete environment, and the probes are monitored frequently or continuously to track changes in the corrosion rate.



**Figure C25. Embeddable LPR Probe (Model 800/800T Corratr Probe)**

### ***Usage***

To determine the electrical resistivity of the concrete, a second CORRATER® probe with stainless steel electrodes may be used. In addition, the probes may be supplied with an integral temperature sensor. Typically, the CORRATER® probes are positioned at the most susceptible locations for corrosion, adjacent to the rebar, but on the side that will see chloride or moisture ingress first. This will allow preventive measures to be taken before the onset of corrosion.

### **Data Collection**

Data may be collected by manually querying the probe at specified intervals, or automatically via a CORRDATA® datalogging system. These instruments enable data to be collected on a frequent and regular basis for subsequent collection and downloading into the CORRDATA® Plus Software for analysis. This ensures continuous monitoring of the corrosion rate.

### **Remote Data Collection System**

The CORRDATA® Remote Data Collectors (RDC's) are used at every CORROSOMETER® and CORRATER® probe location where maximum versatility and sensitivity to corrosion rate changes are required. Readings of corrosion and temperature data may be set to be taken as frequently as every 5 minutes for the CORROSOMETER® system or every 30 minutes for the CORRATER® system.



**Figure C26. Remote data Collection System for Corrater Probe**

Programming of all the RDC's and data retrieval from the RDC's is accomplished by a single CORRDATA® Mate. The CORRDATA® Mate is a portable handheld instrument used to collect and transfer corrosion data from CORROSOMETER® probes or CORRATER® probes. The data can then be transferred to a PC for analysis with CORRDATA® Plus software.

With this system installed, remote probe data can be collected. There are no power requirements or cabling to worry about. Operation consists of the following five simple steps:

1. Install one RDC per probe.
2. Program the RDC automatically from the CORRDATA® Mate.
3. Leave probe(s) unattended to collect corrosion data.
4. Return to the remote location with the CORRDATA® Mate periodically to retrieve the stored data.
5. Transfer the data easily from the CORRDATA® Mate to a PC via an RS232 port for analysis.





**Figure C27. CORRDATA® Mate: Portable, Handheld Instrument Used to Collect and Transfer Corrosion Data from CORROSOMETER® Probes**

For increased versatility, Communication Power Modules (CPM's) provide a wide range of power supply and remote communication options.

CORRDATA® Software provides graphical displays of corrosion data for immediate identification of corrosion upsets. With CORRDATA® Plus Software, multiple probes and additional corrosion parameters, such as temperature from CORROTEMP® Probes, can be simultaneously reviewed.

## **Appendix C1.7: Embedded Instrumentation for Linear Polarization Resistance, Open Circuit potential, and Chloride Ion Concentration – EC1 Probe**

**Company:** *Virginia Technologies Inc.*

**Source:** <http://www.vatechnologies.com/eci.htm>

### ***Description***

The ECI-1 is an embeddable non-destructive corrosion-monitoring instrument. It is capable of measuring parameters important to long term corrosion monitoring including linear polarization resistance (LPR), open circuit potential (OCP), resistivity, chloride ion concentration ([Cl<sup>-</sup>]) and temperature. Each ECI-1 Instrument is a digital peripheral connected on an embedded local area network. EC1 a fully embeddable corrosion monitoring "instrument" incorporating all required electrodes and signal processing electronics. The ECI-1 approach allows the leads connecting the low-level analog signals to signal processing electronics to be kept short (approximately 1 inch). Short analog signal leads allow for a higher signal to noise ratio and more accurate and repeatable measurements. The instruments communicate with each other and an external datalogger using the SDI-12 industry standard protocol. The ECI-1 communicates with other instruments and an external datalogger using a digital protocol, which is highly resistant to corruption from nearby EMI sources.

ECI-1 Enclosure is mounted in place using 4 pieces of #3 re-bar. These pieces of re-bar are wired to the support members of the structure and the ECI-1 becomes a permanent part of the structure after the concrete is set in place. Note that the ECI-1 is not in electrical contact with the structure. A structural analysis must be done to provide assurance and to optimize the trade-off between coverage and impact on structural strength or structural integrity.



**Figure C28. EC1 Probe**

### **Uses**

The ECI-1 has many applications in the construction and maintenance of commercial and civil structures. These structures can include but are not limited to high rise buildings, parking garages, bridges, dams, spillways, flood control channels, piers, pylons and erosion control structures. During construction, engineers, builders and supervisors can monitor parameters such as chloride concentration, resistivity and temperature. These parameters can identify errors at an early stage of construction. One error that may be detectable is the use of sea water or contaminated water during mixing of the concrete ([Cl-]). The moisture content and temperature of the structure can be monitored during the curing process to ensure maximum strength of the concrete. Once construction is complete the instrument can be used to conduct long term monitoring of corrosion conditions.

### **Advantages**

The ECI-1 embeddable corrosion instrument packs 5 sensors into one small package that can be installed and placed wherever needed to provide adequate coverage of a structure during construction. The instruments are modular and uniquely addressable allowing the system to be easily scaled to the needs of the specific structure. The ECI-1 is less susceptible to electro-magnetic interference (EMI) by virtue of its extremely small lead lengths. Many embedded corrosion probing systems rely on external electronics to drive (stimulate) the embedded probes and to measure the resulting signals. Often these measurements have to be made over cables of up to 10 meters in length which can act as antennas for EMI sources such as power lines, cell phones and radio waves. The leads between the electrodes and data acquisition electronics in the ECI-1 are only about 1 inch in length and are converted to digital data right at the source. The data is transmitted over a digital network, which is relatively immune to interference.

ECI attributes include:

- Measures the most pertinent corrosion related parameters
- Contains all required electrodes and electronics
- Serves as a digital network peripheral
- Data resistant to corruption from nearby EMI sources
- Uses the industry standard SDI-12 protocol
- Each network connection can be up to 200 feet in length.
- System can be powered using optional solar collector and rechargeable battery.
- Wireless communication provided via an external cellular transceiver.

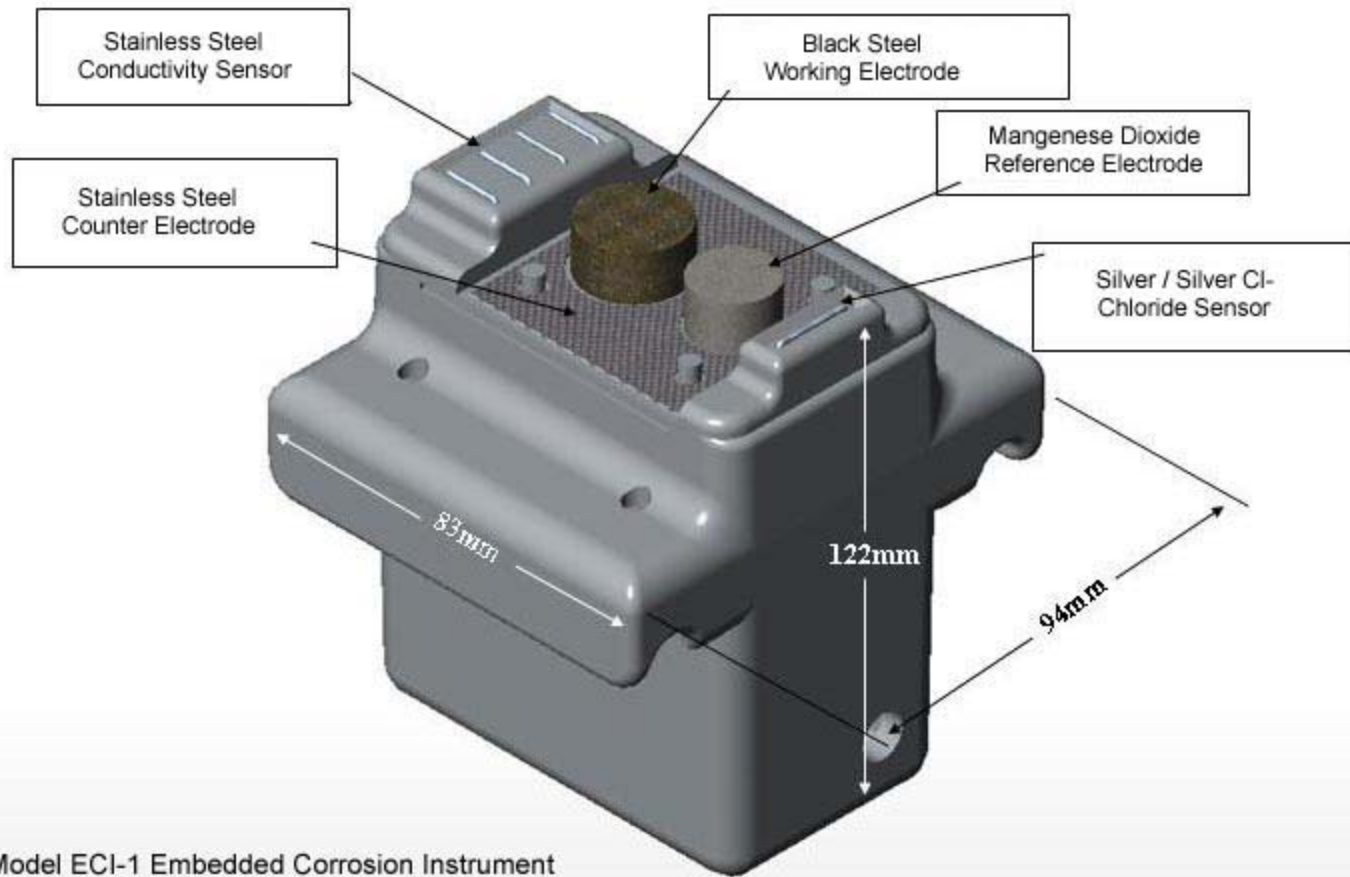

**Figure C29. Model ECI-1 Embedded Corrosion Instrument**

***Operational Principle***

Polarization resistance is measured using the steel working electrode (WE) a stainless steel counter electrode (CE) and a MnO<sub>2</sub> reference electrode (RE). The WE is a sacrificial electrode made of black steel and is meant to corrode at the same rate as ASTM 615/A compliant steel it is monitoring. Defective areas of protective coatings on structural steel such as epoxy or stainless steel cladding can be compared to the corrosion characteristics of black steel. The control module will first initiate the measurement of the OCP between the working and reference electrodes in the potentiostat circuit and apply the appropriate potentiostat drive potential. The drive potential is applied between the counter and working electrodes. A zero resistance ammeter in the potentiostat circuit measures the cell current. The cell current and drive potential are scanned over a range about the OCP and the collected data are used to calculate the polarization resistance. The corrosion rate of the reinforcement steel is inversely proportional to the polarization resistance. As long as the polarization

resistance remains high and the open circuit potential is small in magnitude the reinforcement steel is passive and corroding at a very small rate. As the steel begins to depassivate due to an increase in  $[Cl^-]$  or other corrosive environmental conditions the OCP will become more negative accompanied by a decrease in the polarization resistance.

The resistivity sensor uses four stainless steel electrodes to measure the resistivity of the surrounding concrete. The galvanostat circuit drives a stepped current through the outer pair of electrodes and measures the potential between the inner pair of electrodes at each step. A linear regression is then performed onboard to calculate the resistance between the inner pair of electrodes. This resistance is then multiplied by the cell constant of resistivity sensor to calculate the resistivity of the concrete in units of ohm-cm. This resistivity parameter provides information on the relative amount of moisture in the concrete. The resistivity parameter can also be used with the geometric cell constant of the CE, WE and REF electrodes to correct for ohmic resistance errors in the polarization resistance measurements.

The Ag/AgCl ion specific electrode (ISE) in combination with the reference electrode is used to measure chloride ion concentration. A potential will develop between Ag/AgCl and REF electrodes that is proportional to the local chloride concentration in the concrete surrounding the steel. The chloride measurement results are reported back to the user as one of three specific levels (1=high  $Cl^-$  concentration, 2=moderate  $Cl^-$  concentration, 3=low  $Cl^-$  concentration). A solid state temperature sensor on board provides information on the temperature within the concrete.

The microcontroller sequences all of the sensor measurements and controls sensor drives and data acquisition through the digital-to-analog (DAC) and analog-to-digital (ADC) converters. The microcontroller performs all necessary calculations for corrosion measurements. Data can be stored onboard in local non-volatile memory or it can be directly transmitted via the network connection. A unique address as well as any calibration and location data can be stored onboard. The microcontroller can place the various system components on low power or off modes to provide power management control for low power remote operations (battery powered, solar). Typically, the ECI-1 is used to monitor the corrosion of reinforcement steel in a concrete bridge deck. The instruments are placed within the bridge during construction before the concrete is poured. The ECI-1 is placed with the electrodes facing the top surface of the bridge at the level of the top reinforcement steel. This orientation insures that the sensor electrodes of the ECI-1 encounter the same environmental and corrosion conditions as the reinforcement steel it is monitoring.

The ECI-1 enclosure is engineered to provide environmental and structural protection for the embedded sensors and electronics without compromising the integrity of the structure in which it is embedded. The molded plastic enclosure gives moisture and chemical protection to the instrument's electronics while providing a rigid base for the

electrodes. A flexible waterproof and chemically resistant potting compound is used inside the ECI-1 to provide further water and chemical protection to the electronics and to cushion them from external stress on the enclosure. A small cage of #3 rebar can be placed around the ECI-1 during installation to further isolate the instrument from mechanical stresses. This reinforcement cage also serves to hold the instrument at the

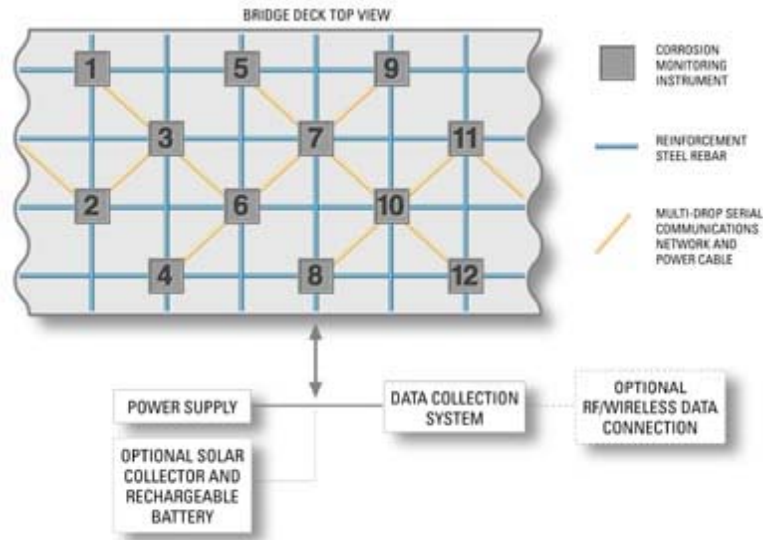

**Figure C30. Schematic of ECI-1 Data Collection, Retrieval and Transmission System**

appropriate level in the structure and is directly attached to the reinforcement mat. The embedded ECI-1 instruments are connected to a multi-drop serial communications network. A variety of network configurations and protocols are possible. The preferred implementation for the ECI-1 is a local area network using the SDI-12 protocol. The SDI-12 protocol is a three-wire sensor to datalogger interface operating at a 1200 bps data rate. The SDI-12 bus consists of +12 volts, ground and data lines. The bus is capable of driving at least 200 feet of cable and each sensor on the bus is individually addressable. Many dataloggers and sensor manufacturers support the SDI-12 protocol.

The data collection system, in this case a datalogger, is located external to the structure in an environmentally protective enclosure such as a NEMA-4 box. The datalogger connects to the multi-drop serial communications network cable exiting the structure. The datalogger supplies power to the SDI-12 network and thus to all of the connected instruments. The datalogger is powered either by local electrical power lines or optionally a battery that is recharged by a solar collector. The datalogger can be programmed to periodically turn the ECI-1 instruments on and off and to issue commands to collect and send data. The datalogger can then timestamp the returning corrosion data with the identification number and location of responding instrument. This data can then be downloaded on site to a laptop or other portable-computing device. Optionally the datalogger can interface with a wireless transceiver or cell phone modem to provide for remote data collection and operation. Once the data and

instrument locations have been collected it can be processed to form a "corrosion map" of the structure. This information can be used to indicate when, where and what kind of maintenance is needed based on the condition of the structure. By knowing the corrosion rate in a structure the remaining life and replacement scheduling can be predicted without costly, time and labor intensive destructive evaluation methods.

***ECI-1 Specifications***

Physical Dimensions	Enclosure and Electrodes: 83 mm (L) x 94 mm (W) x 122 mm (H)
Enclosure Material	VALOX™ Plastic, Epoxy Potted, Water Tight Seal
Chloride Threshold Indicator	Range: Low, Moderate, High Electrodes (2): Ag / AgCl 15 mm (L) x 1 mm (Dia.), MnO <sub>2</sub> reference electrode, Force Institute Model ERE 20
Conductivity / Resistivity Measurement	Range: 15,000 to 1,000 Ohm-cm Electrodes (4): 316L SS (4) 12 mm (L) x 1 mm (Dia.) spaced at 8 mm
Polarization Resistance Measurement	Range: 1 MOhm-cm <sup>2</sup> -> 1 KOhm-cm <sup>2</sup> Electrodes (3): 316L SS counter electrode (1) 18 cm <sup>2</sup> x 1 mm thick, MnO <sub>2</sub> reference electrode, Force Institute Model ERE 20, Steel working electrode 15.5 mm (Dia.) x 10.0 mm (H)
Temperature Sensor	Range: -40° C to +70° C
Estimated Power Requirements	Strain Gauge Inactive: 1.5 mAmps @ 5 Volts < 8 mWatts Strain Gauge (120 Ω) Active: 29 mAmps @ 5 Volts < 150 mWatts
Communications	SDI-12 V1.2 compatible
Strain Measurement	Strain Gauge: supports 1 to 4 element gauges Internal Excitation Source

## **Appendix C1.8: Embeddable Reference Electrode – V-2000 Silver/Silver Chloride Electrode**

**Company:** *(Patented by Corrosionsme systeme D.I. Weitek KEG, Sistrans bei Innsbruck, Austria) and marketed by VETEK Systems Corporation, 6 Oak Road, Elkton, MD 21921. Phone: 410-398-7131*

**Source:** <http://www.veteksystems.com>

V-2000 - permanent, passive, and patented CMS monitoring electrode. Available in lengths from a few inches to 1000 meters. steel connectors which do not cause secondary electro-chemical site concerns.

The reference electrode can be used as a stand-alone ½ cell reference electrode in constructed elements. One has to make a hole, insert the electrode and monitor the potential with time.

In embedded applications, the electrode is placed by wrapping it around the steel rebar in loose spiral. The steel connectors could be used to ensure proper contact. The corrosion activity can be monitored by simply connecting the electrode to a voltmeter. By monitoring the current flow between the electrode and a copper lead pre-installed on the rebar in electrical contact with the rebar having the electrode the corrosion activity can be determined.

In addition, the location of the corrosion can be determined using the principle of time domain reflectometry (TDR). TDR can be used to detect the location of corrosion in a continuous strand of the reference electrode. One sends an electric pulse down the cable (the V-2000 wrapped around steel) and any perturbations in the electric field caused by the magnetic field of the corrosion process can be picked up.



**Figure C31. V-2000 Reference Electrode**



## Typical Monitoring Schemes

### Manual or Automatic Monitoring with the V2000

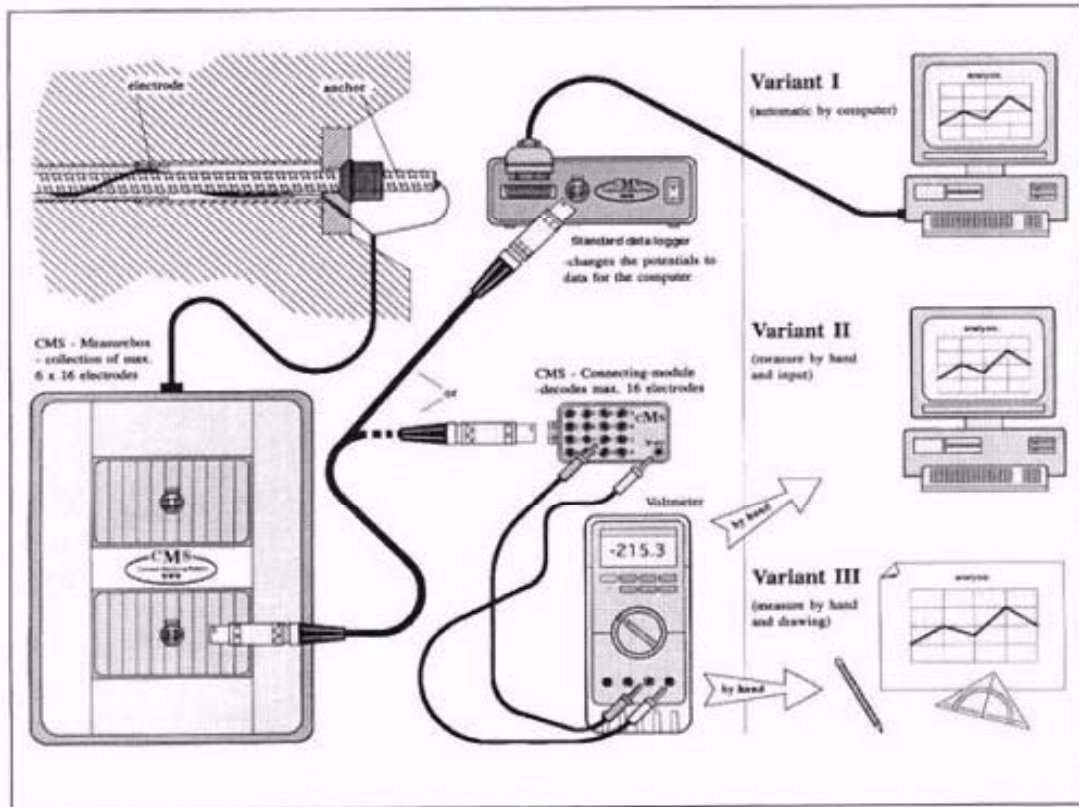
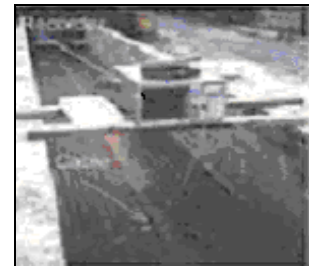
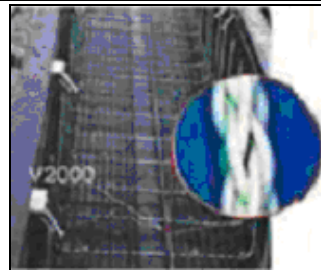

Figure C32. Manual or Automatic Monitoring with the V2000

**Monitoring Techniques in New Construction**

For new bridges, the design engineers working with experienced field maintenance engineers select the areas of the piers, deck and structural cables to be monitored. V2000 monitoring cable is used to monitor rebar, solid steel elements, pretensioning and post tensioning cables. This will signal the start and cessation of corrosion and the intensity of the corrosion. The CPMP units, either standard or advanced, are used for corrosion penetration rate in areas of concern in deck, piers and piers at seawater lines. TDR cable is used to assist in locating corrosion sites, when their existence is indicated by the output of the V2000 cable, on long stretches of cables such as pretensioning, post tensioning, and stay cables.

V2000 Electrode on Rebar		CPMP in Bridge Deck (early version)		TDR Cable for Beam



**Monitoring Techniques in Existing Construction**

For existing structures, some “destruction” is required in order to install the necessary monitoring cables. A good time for this is when repair work is needed due to existing corrosion damage for it tells you the troubled areas of the structure. For rebar, access to within ½ inches of the steel is required. Then the monitoring cable is laid and the new covering concrete is applied. Subsequent monitoring of this area is now possible. Also install CPMP units at this time for corrosion penetration rate data so you can act before the structural steel is again affected. This too is the time to install cathodic protection, if deemed appropriate for the situation. The monitoring system can now inform you as to when to repair the surface coating or when to turn the cathodic protection system on or off and thus maximize that system’s longevity.

For pretensioning and post tensioning cables, if you can cut through the concrete and any covers to within ½ inches of the cables, then these can be monitored. If not, then these cannot be examined. The only exception would be to cut down to near steel casing for a post tensioning cable and install a V2000 and TDR cable there. The monitoring cable would signal attack on the casing and the TDR cable the location. That way field maintenance could be done before the cable itself is attacked or damaged to any large extent.

For stay cables, if plastic coated and steel over coated, then TDR techniques can be directly employed to determine if significant damage is occurring to the steel. If encased in HDPE, external wires can be added and TDR measurements made. When subsequent measurements are then made and compared, significant damage could be detected.

Clearly it is best to plan ahead for problems and maintenance by installing the necessary monitoring system during construction. That way maintenance costs can be minimized.

**Figure C33. Monitoring Techniques in New and Existing Construction with the V2000**

The company does not sell acquisition system. Can setup one by oneself. For the TDR setup to work buy TDR setup from **Pico-seconds Pulse labs** a company out of Colorado. (303) 443-1249

Del-DOT is currently using this system. Iowa DOT and Iowa State monitoring corrosion of MMFX steel bridge. Texas DOT (Prof. Kevin Folliard, UT Austin)

### **Reference Projects**

<b>Project</b>	<b>Location</b>	<b>Type of Applications</b>	<b>Usage</b>	<b>Date</b>
Wurmkogel Cable Cars	Hochgurgl, Tirol, Austria	Pier foundation anchors	V2000 Electrode	1990
Shönberg Avalanche Gallery, Brenner Autobahn	Shönberg, Tirol, Austria	Foundation anchors	V2000 Electrode	1990
Chair Lift Gamsgarten	Stubai Glacier, Tirol, Austria	Pier foundation anchors	V2000 Electrode	1992
First Hawaiian Bank Center	Honolulu, Hawaii	Foundation anchors - 100 percent of anchors (175)	V2000 Electrode	1994
Chapel Maria Schnee	Hall, Tirol, Austria	Foundation & slope retention anchors	V2000 Electrode	1994
Lens Snow Shed	Glacier National Park, Canada	Refurbished Pier Monitoring Probes	V2000 Electrode Probes	1995
Pilsen Arch Bridge	Pilsen, Czech Republic	Deck strengthening tensioning cables, & pillar reinforcement	V2000 Electrode	1995
Noesslach Bridge	A-13, Brenner Autobahn, Tirol, Austria	Pier, deck, & transverse beam refurbishment and cathodic protection installation, reinforcement monitoring	V2000 Electrode	1995
Schlick 2000 Ski Area	Tirol, Austria	Slope retention anchors	V2000 Electrode	1995
Confederation Bridge	Prince Edward Is., Canada	Deck & Pier reinforcement monitoring	V2000 Electrode	1996
Railroad structure, Koroado s.r.o.	Cesko Trebova, Czech Republic	Anchors for large block building foundations and piles	V2000 Electrode	1996
Slope restraint for	Matrei, Tirol, Austria	Slope restraint anchors monitored	V2000 Electrode	1996

<b>Project</b>	<b>Location</b>	<b>Type of Applications</b>	<b>Usage</b>	<b>Date</b>
parking garage at Muehlbachl				
Vereina Train Tunnel	Klosters, Susch/Lavin, Switzerland	Tunnel arcs - steel reinforcement	V2000 Electrode	1996
Public Works of Canada Parking Garage Deck Study	Hull, Canada	Deck Reinforcing Monitoring	V2000 Electrode & Gold Electrode Probes	1997
Inn River Bridge, Hall-West A 12	Inntal Autobahn, Hall, Tirol, Austria	Reinforcing steel, tensioning cables, and deck	V2000 Electrodes and CPMP units	1997
Pinswang Bridge, B314 Fernpass Highway	Reutte, Tirol, Austria	Deck reinforcement	V2000 Electrodes and CPMP units	1997
Old Arch Bridge	Ottawa, Canada	Deck & pier monitoring following reconstruction	V2000 Electrode, Gold Probes, & Advanced CPMP Units	1998
Murderkill River Bridge	Frederica, Delaware	HPC beam prestressing cables and decking	V2000 Electrode, TDR cable, and CPMP unit for deck	1999 & 2000
Fiber Wrap on Piers Study	University of Texas at Austin, Texas	Trial of Corrosion Probes for Study of repaired piers using FRP wraps	V2000 Silver & V1500 Gold Probes	2000
Fiber Wrap on Piers Study	University of Texas at Austin, Texas	Study of repaired piers using FRP wraps for Texas DOT	V2000 Silver & V1500 Gold Probes	2000
Vancouver HPC Beam Bridge	Vancouver, Canada	Monitoring of pretensioning cables in HPC bridge beams	V2000 Electrode	2000

<b>Project</b>	<b>Location</b>	<b>Type of Applications</b>	<b>Usage</b>	<b>Date</b>
Post Hotel	Achenkirch, Tirol Austria	Monitoring of anchors	V2000 Electrode	2000
Railroad Bridge	Czech Republic	Monitoring of prestressed anchors	V2000 Electrode	2000
Lieserschluht Bridge	A10 Tauern Autobahn, Carinthia, Austria	Cathodic Protection for research & monitoring	V2000 Electrode	2000
Vancouver HPC Beam Bridge	Vancouver, Canada	Monitoring of pretensioning cables in HPC bridge beams for chloride content of concrete	V1500 Gold Probes	2001
Dutch Railroad Bridge	Rotterdam, The Netherlands	Monitoring of anchors	V2000 Electrode	2001
Lieserschluht Bridge	A10 Tauern Autobahn, Carinthia, Austria	Cathodic Protection for research and monitoring	CPMP units	2001

### **Appendix C1.9: Permanent Embedded Electrode (Model CB)**

**Company: Electrochemical Devices Inc., P.O. Box 31, Albion, RI 02802-0031  
Phone: (401) 333-6112, Fax: (401) 333-9724**

**Source: <http://www.edi-cp.com>**

#### ***Construction***

- Long term reliability with thermodynamically stable Ag/AgCl element
- Cotton bag housing containing proprietary backfill compatible with concrete provides good electronic and mechanical bonding to the structure

#### ***Applications***

Bridge decks and substructures, parking garages, docks and buildings

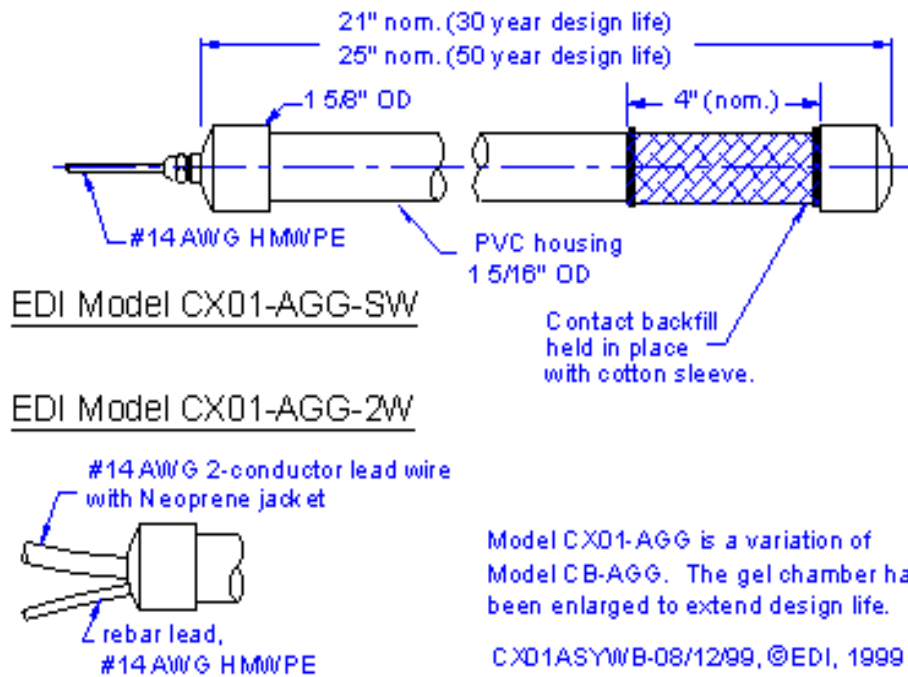

**Figure C34. Permanent Embedded Electrode (Model CB)**

#### ***Extended Life Reference Probe (Model CX01)***

This is a variation of our Model CB. The gel chamber has been enlarged to significantly extend the design life. This product is being used to monitor the potential of a concrete encased steel liner in an aqueduct.

## Extended Life Reference for Concrete



**Figure C35. Extended Life Reference for Concrete (Model CX01)**

## Appendix C1.10: Rebar Probes for Polarization Measurement

**Company:** Electrochemical Devices Inc.

**Source:** <http://www.edi-cp.com>

### **Description**

Model CP-REB-SWnnn probes are used for corrosion rate monitoring by the linear polarization resistance technique. The rebar probe is the working electrode while the rebar net serves as the counter electrode. They are frequently used to monitor reinforced concrete with inhibitors and sealers.

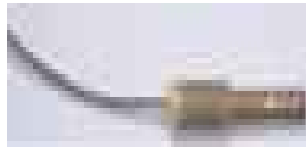

a. Photograph

## Polarization Probe for Concrete

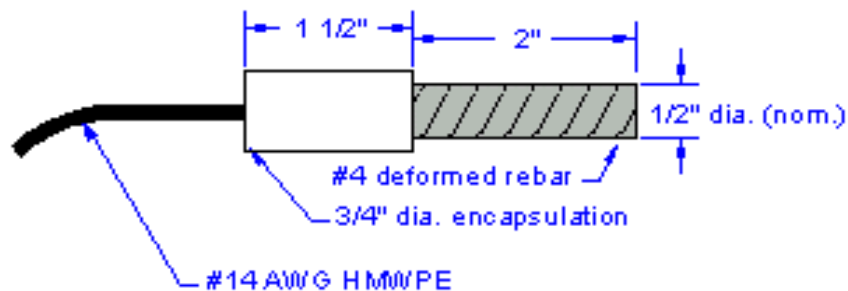

Model CP-REB-SWnnn

nnn in model designation is length of lead wire in feet.

CPREBAS\WB-11/23/99 ©EDI, 1999

### b. Schematic and Dimensions

Figure C36. Polarization Probe (Model CP-REB-SWnnn)



## Appendix C2: Gauges

### Appendix C2.1: Geonor P-280W Weldable Vibrating Wire Strain Gauge for Reliable Monitoring of Strain in Steel and Concrete

- Accurate monitoring of strain in steel and concrete
- Wide span of strain
- Easy installation
- Stainless steel sensor element
- Waterproof to 20 bar of pressure
- Possibility to make static and dynamic measurements
- Long term stability

No signal loss in long cables

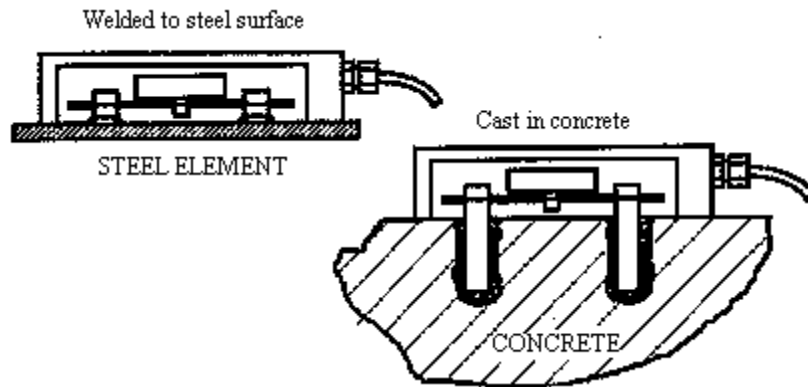

**Figure C37. Geonor P-280W Installation**

### **Applications**

The gauge measures strain or stress on steel and concrete surfaces. Applications include:

- Steel legs and braces on offshore structures
- Steel reinforcing
- Pile load tests
- Surfaces of concrete structures
- Bridges and buildings
- Struted and braced excavations
- Steel beams, columns and tubular elements

The P-280W can be used both for static and dynamic monitoring with appropriate readout equipment. The measuring range can be determined during installation to permit the monitoring of ranges between small and very large-scale strains.

### **Design**

The gauge consists of 3 main parts: strain gauge sensor, posts and cover. The sensor element is a stainless steel tube with a central steel wire clamped to the tube at each

end. Strain in steel or concrete structures is picked up from posts by the wire in the steel tube. The exciter and pickup element keep the wire oscillating and record the frequency. The strain is a function of the resonant frequency measured in the wire. The gauge is a joint design of the Geonor and the Norwegian Geotechnical Institute.

### **Installation**

The posts are installed using a positioning adaptor (Figure C34). For steel surfaces, the posts are welded to the surface using TIG or standard arc welding equipment. For concrete surfaces, the posts are epoxied in drilled holes in the concrete surface. The sensor element attaches to the posts through insert holes. The signal exciter and pickup element are connected to the sensor steel tube and cover. The signal cable is installed and secured.

## **Appendix C2.2: Geonor P-270 Extensometers for Reliable Monitoring of Crack and Joint Displacements**

- Accurate monitoring of crack and joint displacements in concrete and rock
- Available with vibrating wire and LDVT gauges
- Rugged construction
- Stainless steel sensor
- Waterproof to 20 bar of pressure
- Long term stability
- No signal loss in long cables
- Easy to install

### ***Applications***

The gauges are designed to measure joint and crack displacements on concrete and rock surfaces. Applications include monitoring of:

- crack and joint displacements in concrete
- rock boulder movements
- displacement between concrete elements in bridges and structures

P-270 extensometers can be used both for static and dynamic monitoring provided that appropriate readout equipment is used. The choice of LVDT (Linear Variable Differential Transformer) or vibrating wire type sensor depends on the overall design of the remote reading system.

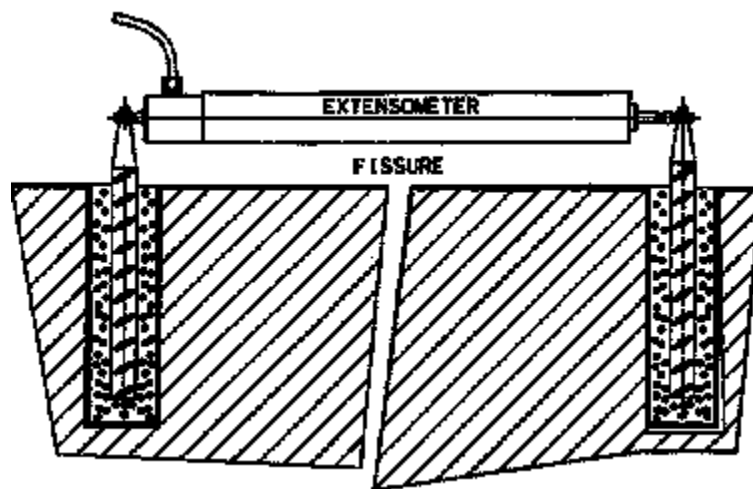

**Figure C38. Geonor P-270 Installation**

### ***Design***

The sensor consists of a pressure proof body and mounting posts. Both vibrating wire and LVDT type extensometers can be used. Measuring ranges between 0-50 mm and 0-400mm are available. Displacement is measured for one direction per sensor. For measurement in two directions, two sensors are connected to the same post on one side of the joint or crack.

***Installation***

The posts are installed in concrete or rock using 12mm anchors epoxied into drilled holes (Figure C35). The sensor is connected to the posts by universal joints. The cable is secured to the rock or concrete surface by steel tubing or other protective means.

### **Appendix C2.3: Geonor Vibrating Wire P-600 Uniaxial Inclinometer for Structures and Foundations**

- Designed for hostile environments
- High accuracy and resolution
- Robust design
- Vibrating wire technology
- Ideal for bridges, structures and buildings
- Pressure tested to 20 bar
- Operating ranges between +/- 1 and 45 degrees
- Built in redundancy

#### **Applications**

The sensor is designed for stationary monitoring of the inclination of large structures.

Some relevant applications are:

- Bridges
- Offshore structures
- Slopes
- Subsea structures
- Foundations

The P-600 inclinometer has an excellent signal resolution and accuracy. The signal can be transmitted over more than 2000 m cable length without signal loss.

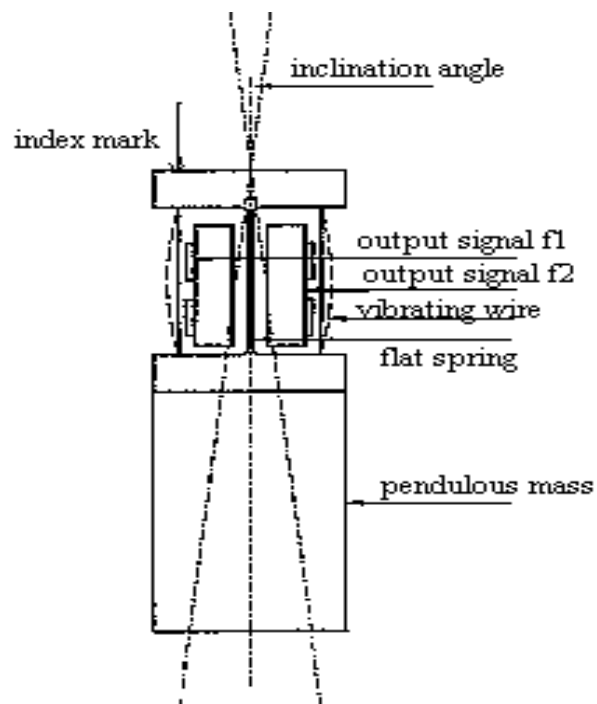

**Figure C39. Schematic of Geonor P-600**

### ***Design***

The sensing element of the inclinometer consists of a pair of vibrating wire strain gauges. Within the body of the inclinometer is a flat leaf spring, one end of which is fixed to the housing of the inclinometer and thus to the structure. Attached to the free end of the spring is a pendulous mass. Mounted on each side of the spring, thus providing additional redundancy in the measurements, is a vibrating wire gauge with exciter and pickup system attached. Changes in the inclination of the instrument produce a bending of the spring due to the pendulous mass. The tensions of the gauge wires change, giving change in the resonant frequencies of vibration of the wires. This frequency is a measure of inclination of the structure to be monitored.

## **Appendix C2.4: The SOFO System – Single Deformation System**

Source: [www.smartec.ch](http://www.smartec.ch)



**Figure C40. SOFO System Setup**

### ***Operating Principle***

The deformation sensors are transducers that transform a distance variation into a change in the path unbalance between two optical fibers that can be measured with the SOFO reading units. The sensor is composed of two main parts, an active and a passive one. The active part contains the reference and the measurement fibers and measures the deformations between its two ends. The passive part is insensitive to deformations and is used to connect the sensor to the reading unit. The output is terminated with an E-2000 connector having a built-in protect cover. The sensors can be quickly and easily installed without affecting the construction schedule. They can be directly embedded in concrete and mortars, or surface mounted. This sensors is adaptable to other measurement principles and is optionally available in the duplex configuration (separate lead-in and lead-out fibers) or without integrated coupler.

### ***Advantages of the SOFO system:***

- High resolution
- Embeddable or surface mountable
- Temperature insensitive
- Immune to corrosion and vibrations
- Immune to electromagnetic fields
- Waterproof
- No calibration required
- Easy to install
- Long lifetime

### Technical Details

The measuring system is based on the principle of low-coherence interferometry (see figure). The infrared radiation of a light emitting diode (LED) is injected into a standard single mode fiber and directed, through a coupler, towards two fibers installed inside the structure to be monitored. The measurement fiber is in mechanical contact with the structure itself and will therefore follow its deformations in both elongation and shortening. The second fiber, called reference fiber, is installed free in the same pipe. Mirrors, placed at the end of both fibers, reflect the light back to the coupler, which recombines the two beams and directs them toward the analyzer. This one is also made of two fiber lines and can introduce a well-known path difference between them by means of a mobile mirror. On moving this mirror, a modulated signal is obtained on the photodiode only when the length difference between the fibers in the analyzer compensates the length difference between the fibers in the structure to better than the coherence length of the source (in our case some hundreds of mm). Each measurement gives a new compensation position reflecting the deformation undergone by the structure relative to the previous measurement points. The reading unit can therefore be disconnected and used to monitor other fiber sensors and other structures.

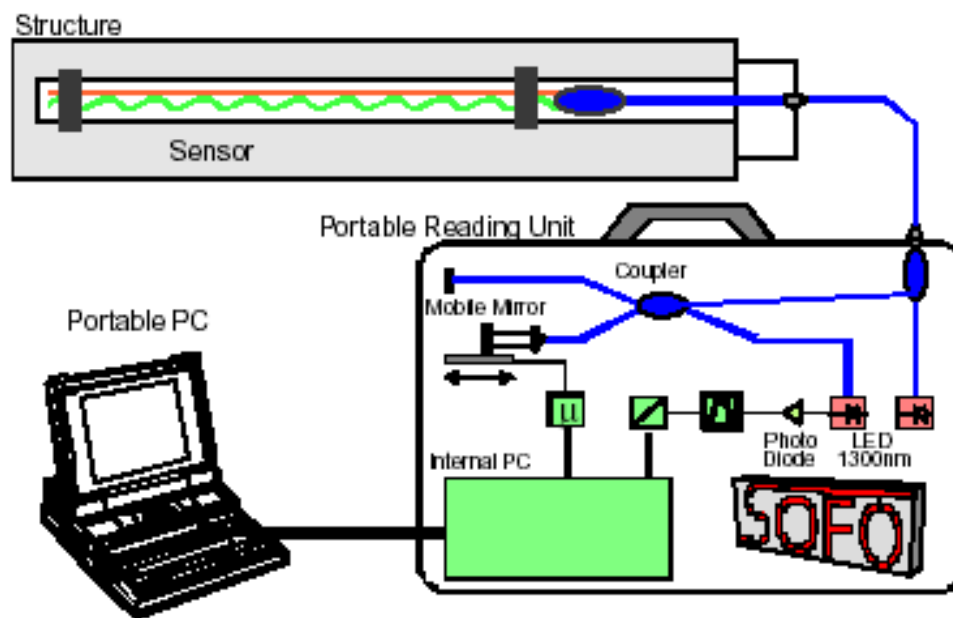

Figure C41. Operating Principle of the SOFO Sensor



## **Appendix C2.5: SM 2001 Structure Monitoring System**

**Source:** [www.smartec.ch](http://www.smartec.ch)

The Structure-Monitoring-System SMS 2001<sup>®</sup> is used for multi-component-analysis of dynamic and static structural parameters. This concerns especially cost-effective and maintenance-free remote monitoring of structures and comparable objects of different kinds. With the SMS 2001<sup>®</sup> measuring data can be recorded, collected and transferred over the entire observation period both continuously and depending on an event. Therefore the SMS 2001<sup>®</sup> makes analysis of static and dynamic structural reactions on user actions and environmental influences possible. By this way comprehensive information about the structural behavior over the observation period can be achieved.

Because SMS 2001<sup>®</sup> was developed especially for continuous and long term monitoring of structures, it provides compared with conventional solutions especially the following advantages:

- SMS 2001<sup>®</sup> allows long term observation of structures without worth mentioning personnel resources on site. Distances between the location of observation and the central office are irrelevant.
- SMS 2001<sup>®</sup> can be adapted flexible to the individual existing specification of the measuring task.
- SMS 2001<sup>®</sup> is in all aspects completely configurable from the central office. This concerns both the measurement configuration and the data transmission.
- SMS 2001<sup>®</sup> is space-saving for its system-components at the observation location and therefore it has convenient requirements for the protection against weather influences and vandalism.
- SMS 2001<sup>®</sup> has a broad selection platform of useable sensors for a huge number of measurands.
- SMS 2001<sup>®</sup> causes reasonable costs for the user as a result of the above mentioned advantages.

The SMS 2001<sup>®</sup> was developed by the [Infokom GmbH Neubrandenburg](#) Neubrandenburg in cooperation with [Jenasensoric e.V.](#) and the [Bauhaus-University Weimar](#), Department for Experimental Investigation. Particularly because of the gaining of valuable experiences from first pilot objects and the formulation of practically orientated user demands the cooperation with the Bauhaus-University has proven profitable.

For SMS 2001<sup>®</sup> there is a huge number of application possibilities, where traditional measuring methods are unsuitable or too expensive. Examples for such application fields are:

- Monitoring of long-term processes, e.g. structural reactions to subsoil setting as well as their tendency and their rate of speed

- Registration of selected measuring quantities ( displacement, vibration) as a function of time-dependent ambient conditions (temperature, humidity)
- Compiling and evaluation of characteristic parameters of new structures including static and dynamic loading values during a long period of time
- Judgement of efficiency of renovation- or strengthening works on structures by long-term monitoring of characteristic parameters
- Observation of alterations at structures or structural elements due to special events (e.g. detonations) in the course of an evidence based negotiation
- Verification of loading assumptions of exceptional structures over prolonged periods of time

In the above stated and in a lot of other cases SMS 2001<sup>®</sup> provides measurement data as a signal of significant structural changes a long time before visible damages occur.

#### Reference Examples (2):

- Control of structural reactions as a result of environmental conditions and gaining of information about the intensity of loading on a road **bridge over the Elbe-Seiten-Kanal near Bad Bevensen.**



- Supervision of the remaining service life after a loading test of the **bridge over the river Ilm in Darnstedt (Bad Sulza / Thuringia)** by long-term monitoring

