

Research and Develop Locking Design for NJDOT Junction Boxes

Final Report

April 2009

Submitted by

Cambridge Systematics, Inc.

KS Engineers



NJDOT Research Project Manager

Stefanie Potapa

In cooperation with

New Jersey
Department of Transportation
Bureau of Research

DISCLAIMER STATEMENT

“The contents of this report reflect the views of the author(s) who is (are) responsible for the facts and the accuracy of the data presented herein. The contents do not necessarily reflect the official views or policies of the New Jersey Department of Transportation of the Federal Highway Administration. This report does not constitute a standard, specification, or regulation.”

TECHNICAL REPORT
STANDARD TITLE PAGE

1. Report No. NJ-2008-002	2. Government Accession No.	3. Recipient's Catalog No.	
4. Title and Subtitle Research and Develop Locking Design for NJDOT Junction Boxes		5. Report Date April 2009	6. Performing Organization Code
7. Author(s) Harry Baker, Mizanur Choudhury, Hugh Louch		8. Performing Organization Report No.	
9. Performing Organization Name and Address Cambridge Systematics, Inc. 33 E. 33rd Street, Suite 804 New York, NY 10016 KS Engineers, P.C. 494 Broad Street, 4th Floor Newark, NJ 07102		10. Work Unit No.	11. Contract or Grant No.
12. Sponsoring Agency Name and Address New Jersey Department of Transportation PO Box 600 Trenton, New Jersey 08625		13. Type of Report and Period Covered	14. Sponsoring Agency Code
15. Supplementary Notes			
16. Abstract The report outlines the guidelines for securing electrical junction box covers to the junction box to prevent vandalism. The report provides details drawings that show various methods for securing the junction box cover to the junction box.			
17. Key Words Junction boxes, copper wire, pedestrian and non-pedestrian areas,		18. Distribution Statement	
19. Security Classif. (of this report) Unclassified	20. Security Classif. (of this page) Unclassified	21. No of Pages 9	22. Price

New Jersey Department of Transportation
Form DOT F 1700.7 (8-69)
PO 600
Trenton, NJ 08625

Federal Highway Administratio.

ACKNOWLEDGEMENTS

The author(s) wish to thank various staff members without whom this rewrite would not have been possible, including: Mizanur Choudhury.

TABLE OF CONTENTS

	Page
EXECUTIVE SUMMARY	1
BACKGROUND	1
OBJECTIVES	1
INTRODUCTION	1
SUMMARY OF WORK PERFORMED	2
CONCLUSIONS AND RECOMMENDATIONS	3
APPENDIX A – Junction Box Detail for Iowa DOT Junction Box	4
APPENDIX B – Detail Design of Junction Boxes Located in Non-Pedestrian Areas .	5
APPENDIX C – Detail Design of Junction Boxes Located in Pedestrian Areas	6

LIST OF FIGURES

	Page
Figure 1. Junction Box Detail for Iowa DOT Junction Box.....	7
Figure 2. Detail Design of Junction Boxes Located in Non-Pedestrian Areas	8
Figure 3. Detail Design of Junction Boxes Located in Pedestrian Areas	9

EXECUTIVE SUMMARY

The New Jersey Department of Transportation (DOT) has been experiencing vandalism of the copper cables located with their junction boxes. Vandals have been opening the covers and removing the copper wire. The removal of the copper wire has caused light failures. Furthermore, it is also dangerous because of the voltage that the copper wires carry. The team conducted research with other DOTs to determine if there were existing solutions to this challenge. Based on a review of several DOT websites and phone conversations, it was determined that a design specific for New Jersey DOT was required. The team designed several options for New Jersey DOT to consider for both pedestrian accessible and non-accessible areas.

BACKGROUND

The New Jersey Department of Transportation (DOT) has been experiencing vandalism of the copper cables located with their junction boxes. Vandals have been opening the covers and removing the copper wire. The removal of the copper wire has caused light failures. Furthermore, it is also dangerous because of the voltage that the copper wires carry.

OBJECTIVES

The objective of this project was to assist the New Jersey Department of Transportation Commission in identifying options to lock junction box covers.

INTRODUCTION

The New Jersey Department of Transportation (DOT) has been experiencing vandalism of the copper cables located with their junction boxes. Vandals have been opening the covers and removing the copper wire. The removal of the copper wire has caused light failures. Furthermore, it is also dangerous because of the voltage that the copper wires carry. Our task was to research other Department of Transportation's (DOT's) and possible vendor, that manufacture junction boxes to be determined how the cover could be locked.

SUMMARY OF WORK PERFORMED

Research team members reviewed information available from transportation agency websites and contacted several agencies by phone to identify potential locking solutions for NJDOT. Contacts were made with the following agencies:

- Iowa DOT;
- New York State DOT;
- North Carolina DOT;
- Florida DOT;
- Massachusetts Highway Department;
- New Jersey Transit (NJT); and
- Union County, New Jersey.

For all of the State DOTs except Iowa, junction box details showed the cover placed without screws or any type of security system. For the Iowa DOT, the junction box detail shows eight screws that are placed around the circumference of the cover. The top of the screws can be turned by using a flat head screw driver. The stainless steel screw passes through a gasket and then continues to the inside flange of the junction box. A copy of this detail is shown in Appendix A.

The NJ Transit (NJT) website was also reviewed. NJT does use a spring with a large bolt located in the middle of the box. This type of junction box locking system is only used for the Newark Light Rail. We were not able to find any other information regarding the locking junction boxes for other NJT projects.

Union County, New Jersey has a detail for locking their quartz boxes. They use small screws to secure the cover to the box. The quartz boxes are used in the installation of the traffic signals.

Based on the research and conversations conducted with these agencies, they are not experiencing the same vandalism as NJDOT. Therefore, the existing NJDOT electrical junction box was examined and several possible design alternatives for locking the cover were developed.

CONCLUSIONS AND RECOMMENDATIONS

Options for locking NJDOT's junction box covers were identified separately for boxes in non-pedestrian, non-vehicle areas and in pedestrian areas.

For junction boxes in non-pedestrian or non-vehicle areas (i.e., boxes located in grass areas), a detail design option are shown in Appendix B. Two stainless steel bars would be placed over the top of the junction box cover and either secured on the ends of the box by a threaded screw or hinged on one end and secured with a nut that has a lock on top to prevent vandalism.

For junction boxes located in pedestrian areas, a detail design is shown in Appendix C. For this type, there are two options.

- The first option would use a bolt and nut with a built in lock to secure the cover the concrete box. There would be four locations shown in detail in the upper left hand corner of the detail. The nylon insert jam lock is shown in the upper right hand corner of the detail. The detail of the nut is star shaped to prevent a person from just being able to unscrew the nut easily. The bolt is recessed into the opening as shown in the bottom right hand corner. This will make it harder for someone to remove the nut and bolt to open the junction box cover.
- Another option is to use a screw with a star head on the top. NJDOT would have to have a tool manufactured with this particular star shape in order to remove the screw. We examined using hex heads and other similar type of shapes but we believe that to provide the maximum protection, an irregular shape should be used.

NJDOT could opt for any of these options. Once an option is chosen, NJDOT could cast new junction box covers with the holes predrilled. Then the holes would need to be drilled into the concrete junction box as shown on the details. The recommendation is to use quick setting non-shrink grout to hold the bolt in place. The non-shrink grout will provide the strongest bond between the bolt and the concrete. Other options such as using concrete or some other type of bonding agent are not prudent because they will crack and the bolt will become free and could be removed. For brand new installations, the junction box and cover could be cast for easy installation in the field. This would provide NJDOT with the greatest flexibility.

APPENDIX A – Junction Box Detail for Iowa DOT Junction Box

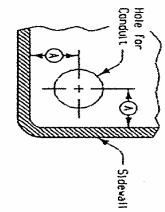
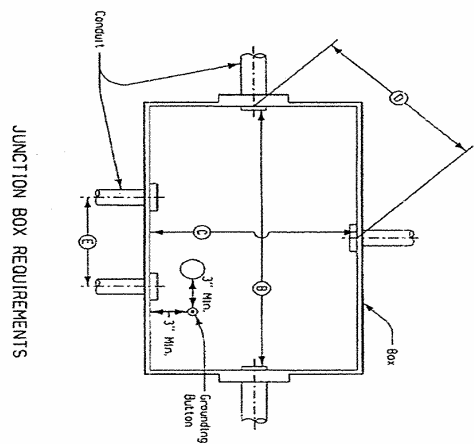
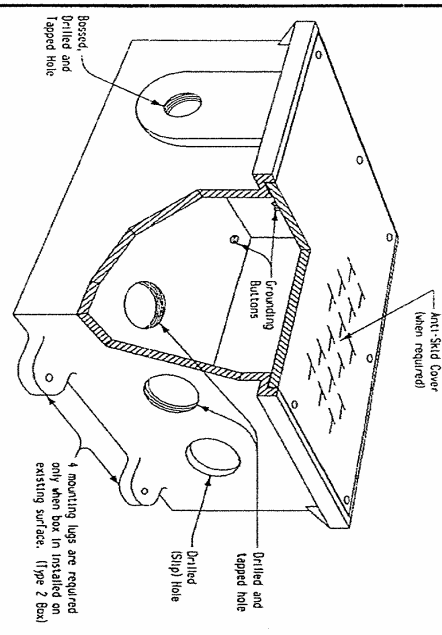

CONDUIT LOCATION FOR LOCK NUT AND BISHOP CLEARANCE - "X"

Conduit Size	1/2"	3/4"	1"	1 1/4"	1 1/2"	2"	2 1/2"	3"	3 1/2"	4"
Minimum Clearance	1"	1 1/4"	1 1/2"	1 3/4"	2"	2 1/4"	2 1/2"	2 3/4"	3"	3 1/2"

MINIMUM SPACING BETWEEN CONDUIT CENTERS - "E"

Size	1/2"	3/4"	1"	1 1/4"	1 1/2"	2"	2 1/2"	3"	3 1/2"	4"
1 1/2"	1 3/4"	2"	2 1/4"	2 1/2"	2 3/4"	3"	3 1/4"	3 1/2"	3 3/4"	4"
1"	2"	2 1/4"	2 1/2"	2 3/4"	3"	3 1/4"	3 1/2"	3 3/4"	4"	4 1/4"
1 1/4"	2 1/4"	2 3/4"	3"	3 1/4"	3 1/2"	3 3/4"	4"	4 1/4"	4 1/2"	4 3/4"
2"	3"	3 1/4"	3 1/2"	3 3/4"	4"	4 1/4"	4 1/2"	4 3/4"	5"	5 1/4"
2 1/2"	3 1/2"	3 3/4"	4"	4 1/4"	4 1/2"	4 3/4"	5"	5 1/4"	5 1/2"	5 3/4"
3"	4"	4 1/4"	4 1/2"	4 3/4"	5"	5 1/4"	5 1/2"	5 3/4"	6"	6 1/4"
3 1/2"	4 1/2"	4 3/4"	5"	5 1/4"	5 1/2"	5 3/4"	6"	6 1/4"	6 1/2"	6 3/4"
4"	5"	5 1/4"	5 1/2"	5 3/4"	6"	6 1/4"	6 1/2"	6 3/4"	7"	7 1/4"

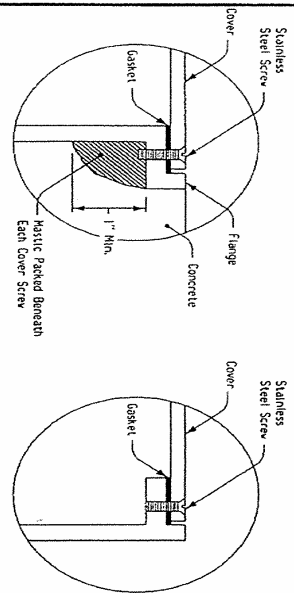

CORNER DETAILS OF JUNCTION BOX

GENERAL NOTES:

The details indicated herein are for typical junction boxes used in electrical circuitry for highway lighting. Alternate designs may be submitted to the Engineer for approval.

Materials and methods of construction shall be in accordance with current Standard and Supplemental Specifications.

Refer to appropriate Standard Road Plans and project plans for additional details.

Type 1 Junction Boxes shall conform to the requirements of NEMA 4 - "Watertight", UL approved, and be of the outside flange variety as shown.

Type 2 Junction Boxes shall conform to the requirements of NEMA 3 - "Raintight", UL approved, and be of the inside flange variety as shown.

Covers of junction boxes installed in locations subject to pedestrian traffic shall have an approved anti-skid pattern. Approved galvanized steel covers may be substituted for cast iron.

Grounding buttons shall be fitted with 3/8" x 3/4" brass screws unless otherwise specified.

Type, size and location of holes will be shown on the plans. Drilled and tapped holes shall be bossed, if necessary, to provide 5 full threads.

Slip holes shall be used only for junction box drains unless otherwise specified on plans.

Iowa Department of Transportation
Project Development Division

STANDARD ROAD PLAN RM-37

REVISION No. 1 - Revised Standard Road Plan RM-37

DESIGNED BY: *John E. Clough* 12-28-98

APPROVED BY: *John E. Clough* 01-27-99

REVISION No. _____

DESIGNED DATE _____

APPROVED DATE _____

JUNCTION BOX
(CAST IRON)

APPENDIX B – DETAIL DESIGN OF JUNCTION BOXES LOCATED IN NON-PEDESTRIAN AREAS

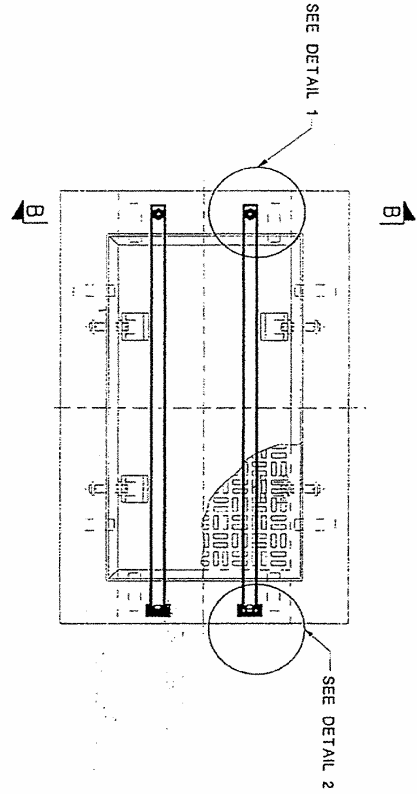

LOCKING EXISTING JUNCTION BOX
TO BE USED IN NON PEDESTRIAN AREAS

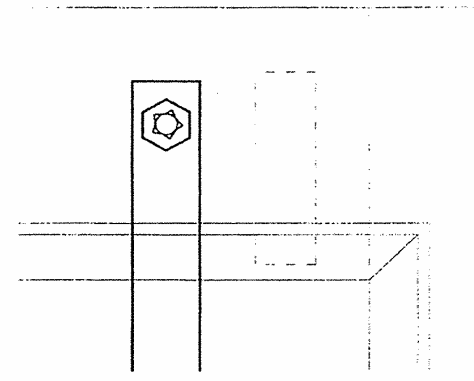

DETAIL-1

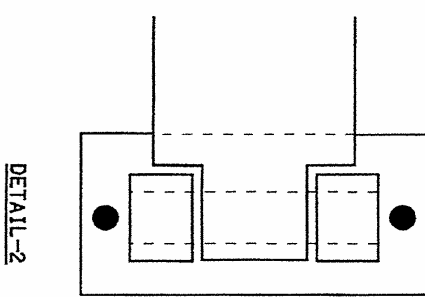

DETAIL-2

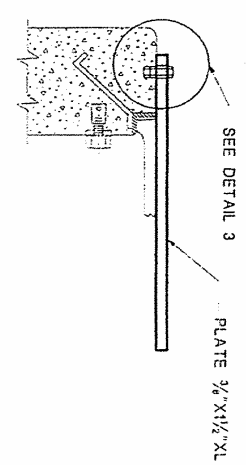

SECTION B-B

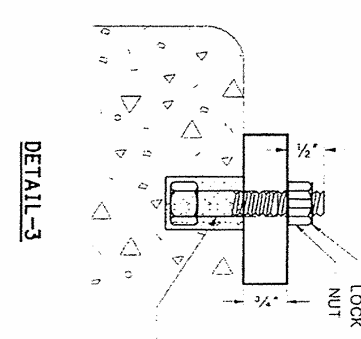

DETAIL-3

1/2" DIA. HEX. BOLT AT END, PLACING HEAD DOWN INSIDE. PRE DRILLED HOLE MADE IN CONCRETE LARGER THAN OVERALL HEAD DIA. AFTER PLACING OF BOLT, FILL AROUND WITH EPOXY RESIN OR NON SHRINKABLE GROUT

APPENDIX C – DETAIL DESIGN OF JUNCTION BOXES LOCATED IN PEDESTRIAN AREAS

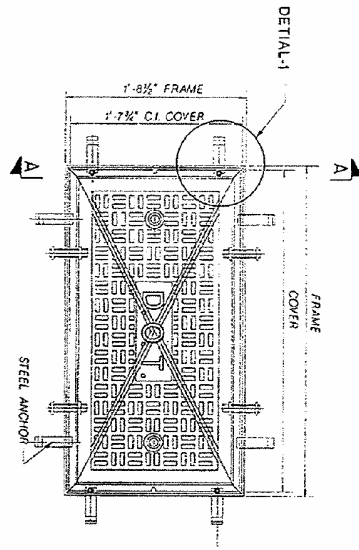

LOCKING EXISTING JUNCTION BOX
TO BE USED IN PEDESTRIAN AREAS

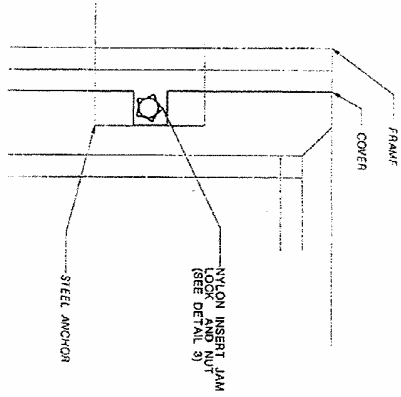

DETAIL-1

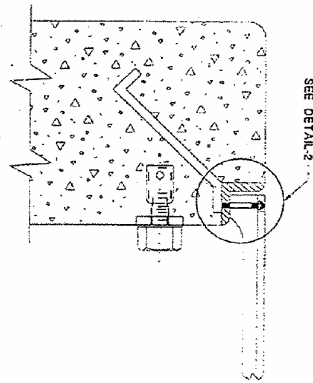

SECTION A-A

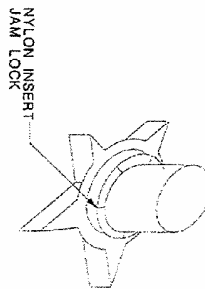

DETAIL -3

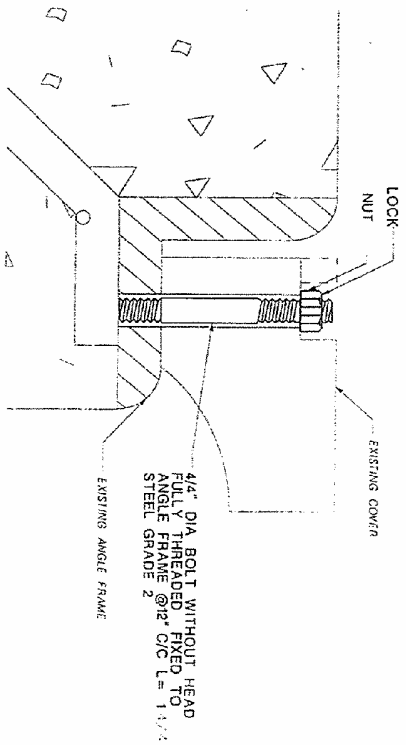

DETAIL-2