

REINFORCEMENT STEEL FOR 12'-0" WIDTH SLAB

NOTES:

- REINFORCEMENT STEEL MATS DIFFERING WITH RESPECT TO THEIR LENGTH, SPACING OF TRANSVERSE REINFORCEMENT STEEL AND TYPE OF FABRICATION FROM THE MAT SHOWN IN THESE DRAWINGS MAY BE USED, PROVIDED THAT (a) THE MATS HAVE THE SAME SIZE AND SPACING OF LONGITUDINAL REINFORCEMENT STEEL, AND PROVIDE AT LEAST THE SAME NUMBER OF TRANSVERSE REINFORCEMENT STEEL PER SLAB, AS CALLED FOR IN THESE DRAWINGS, AND (b) APPROVAL FOR USE HAS BEEN OBTAINED FROM THE DEPARTMENT.
* SEE SLAB CHART
- AN EDGE CLEARANCE OF 3" IS REQUIRED OF OUTSIDE LONGITUDINAL REINFORCEMENT STEEL. SPACE REINFORCEMENT STEEL EVENLY ACROSS WIDTH OF SLAB WITH A MAXIMUM SPACING OF 7 1/2" FOR SLABS WITH A THICKNESS OF LESS THAN 10" AND 6" FOR SLABS WITH A THICKNESS OF 10" OR GREATER.

REINFORCEMENT REQUIREMENTS WHEN USING WELDED STEEL WIRE FABRIC

SLABS LESS THAN 10 INCHES THICK:

- USE SIZE NO. W8.6 LONGITUDINAL WIRE SPACED 6 INCHES ON CENTER.
- USE SIZE NO. W4.7 TRANSVERSE WIRE SPACED 12 INCHES ON CENTER.
- ENSURE THAT THE EDGE CLEARANCE IS 3 INCHES FOR OUTSIDE LONGITUDINAL WIRE.
- ENSURE THAT THE MAXIMUM EDGE CLEARANCE IS 11 INCHES FOR THE LAST TRANSVERSE WIRE.
- ENSURE THAT THE END CLEARANCE IS BETWEEN 1 INCH AND 3 INCHES FOR THE LONGITUDINAL WIRE.
- ENSURE THE LONGITUDINAL WIRES ARE LAPPED A MINIMUM OF 12 INCHES.

SLABS 10 INCHES THICK OR GREATER:

- USE SIZE NO. W10.5 LONGITUDINAL WIRE SPACED 6 INCHES ON CENTER.
- USE SIZE NO. W5.5 TRANSVERSE WIRE SPACED 12 INCHES ON CENTER.
- ENSURE THAT THE EDGE CLEARANCE IS 3 INCHES FOR OUTSIDE LONGITUDINAL WIRE.
- ENSURE THAT THE MAXIMUM EDGE CLEARANCE IS 11 INCHES FOR THE LAST TRANSVERSE WIRE.
- ENSURE THAT THE END CLEARANCE IS BETWEEN 1 INCH AND 3 INCHES FOR THE LONGITUDINAL WIRE.
- ENSURE THE LONGITUDINAL WIRES ARE LAPPED A MINIMUM OF 12 INCHES.

SLAB CHART FOR THICKNESS LESS THAN 10"														
* WIDTH OF SLAB	3'	4'	5'	6'	7'	8'	9'	10'	11'	12'	13'	14'	15'	16'
NUMBER OF LONGITUDINAL REINF. STEEL	5	6	8	9	11	13	14	16	17	19	21	22	24	25

SLAB CHART FOR 10" THICKNESS OR GREATER														
* WIDTH OF SLAB	3'	4'	5'	6'	7'	8'	9'	10'	11'	12'	13'	14'	15'	16'
NUMBER OF LONGITUDINAL REINF. STEEL	6	8	10	12	14	16	18	20	22	24	26	28	30	32

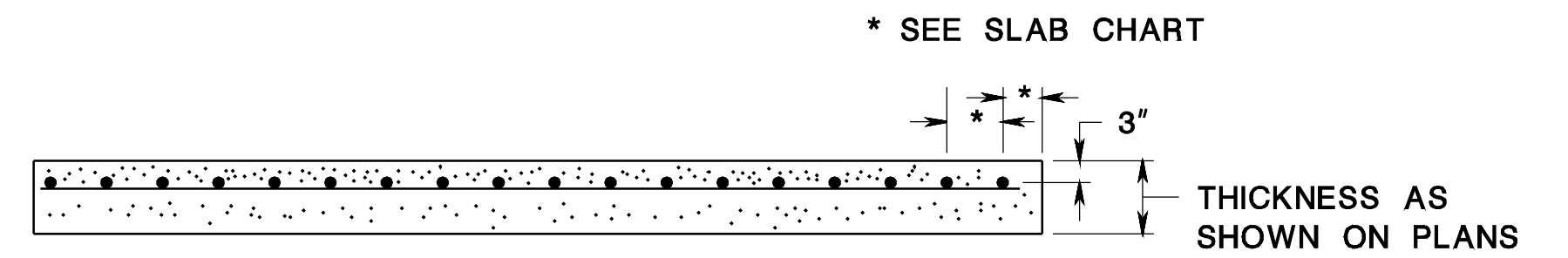

SECTION A-A

REINFORCEMENT STEEL FOR FULL DEPTH CONCRETE PAVEMENT REPAIR, CLASS

FULL DEPTH CONCRETE PAVEMENT REPAIR
N.T.S.

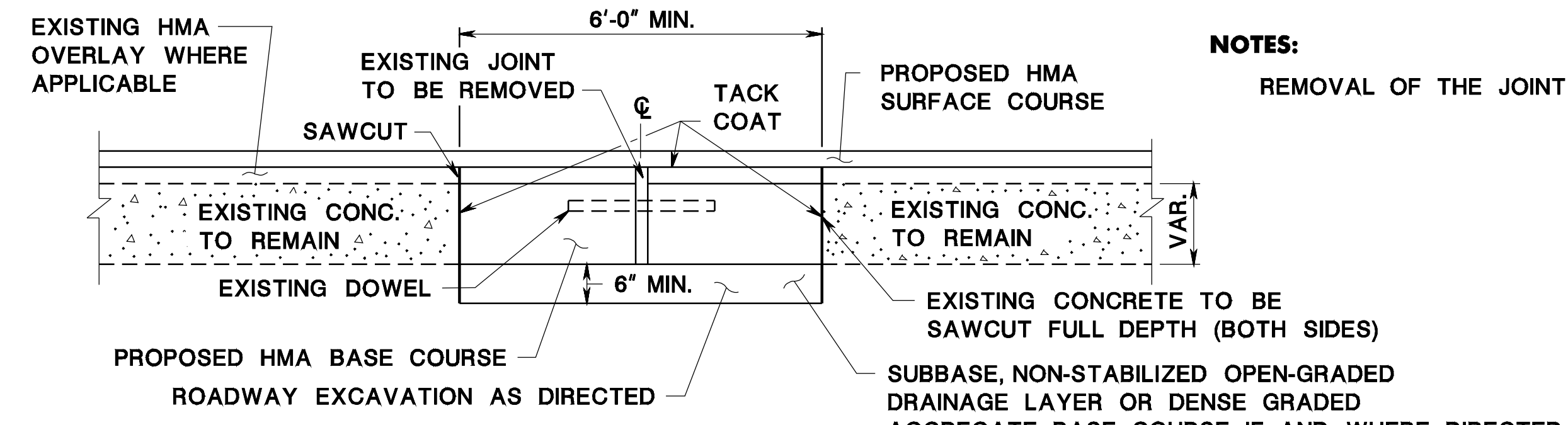

NOTES:

REMOVAL OF THE JOINT SHALL BE AS DIRECTED.

FULL DEPTH CONCRETE PAVEMENT REPAIR, HMA

NOTE:

REINFORCEMENT STEEL ARE IN METRIC UNITS.

NEW JERSEY DEPARTMENT OF TRANSPORTATION

CONSTRUCTION DETAILS

CD-453-2.2

CD-453-2.1

CD-453-2

pen table= \\njdotprjws\vsystem\NJDOT\Projects\NJDOTEng\Plot\TBLs\Roadway\basic.tbl
scale= 30.0000000:1.0000000
date= 17-DEC-2007 09:41
ID= TFXBHAY
BDC0703-ORIGINAL SHEET