

pen table= \\n\jdotprjws\vsystem\jdotprjws\Projects\NJDOTEng\Plot\TBLS\Roadway\basic.tbl
 scale= 30.0000000:1.0000000
 date= 17-DEC-2007 09:44
 ID= TPXBHAY
 BDC0703-ORIGINAL SHEET

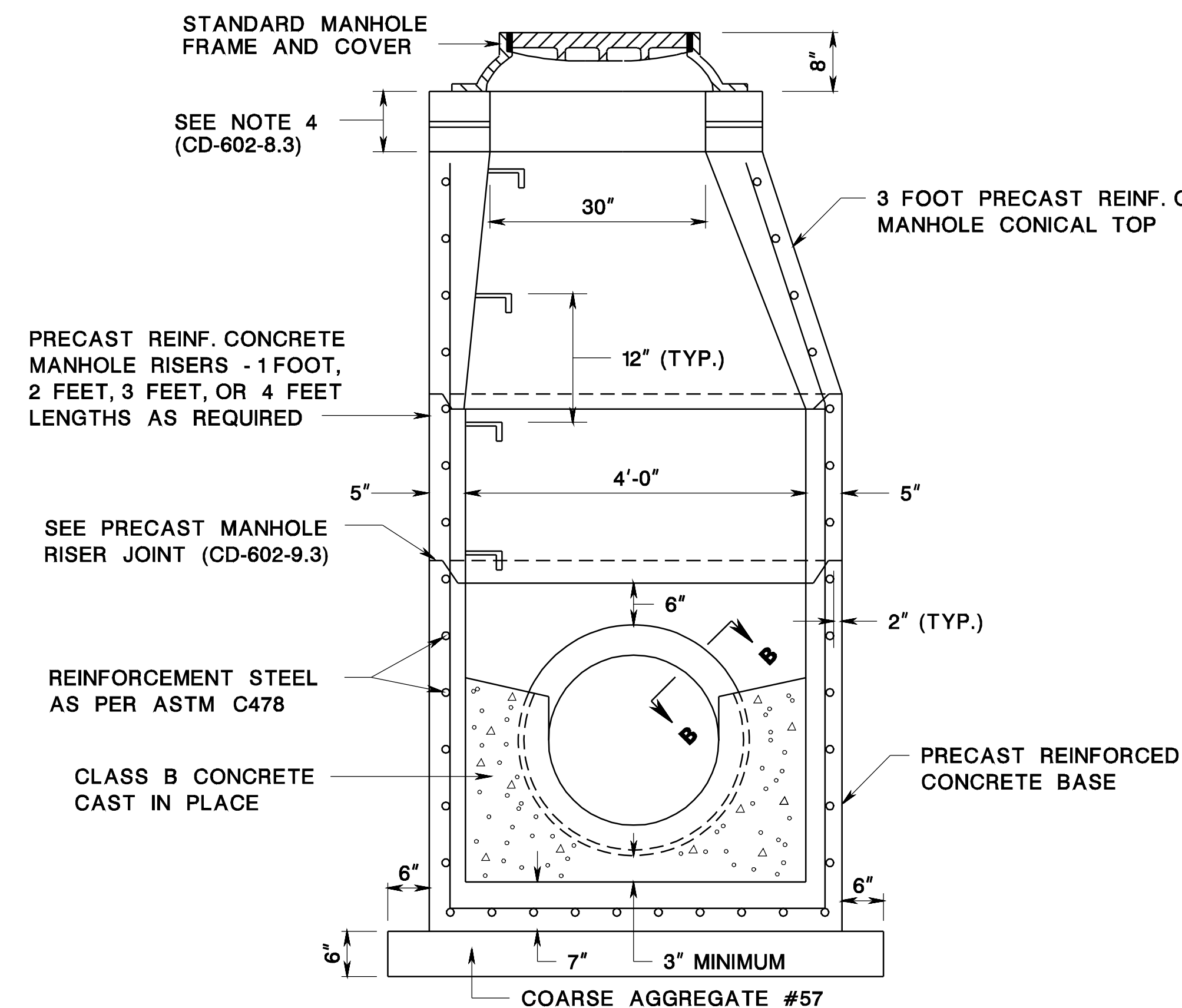

PRECAST REINFORCED CONCRETE MANHOLE SECTIONS SHALL CONFORM TO ASTM C478

**MANHOLES
 PRECAST CONCRETE**

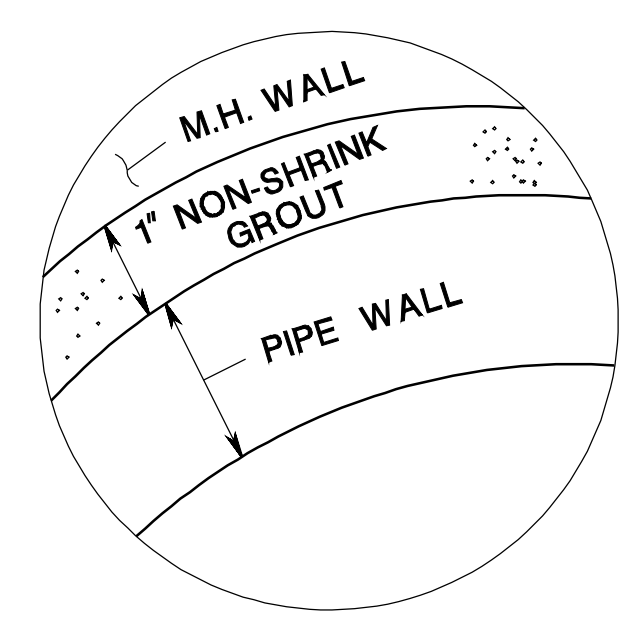

SECTION B-B

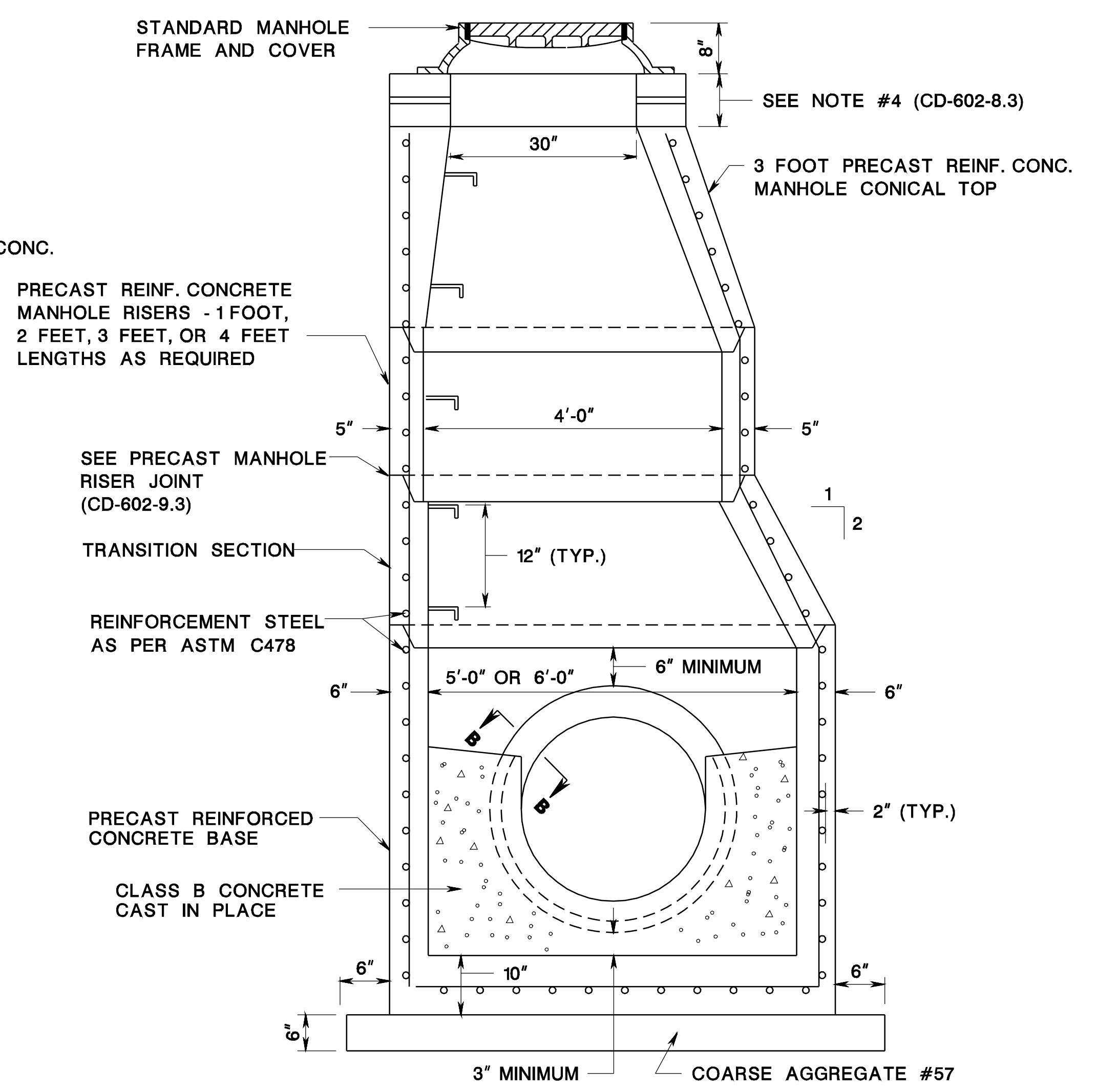

**MANHOLES 5' DIAMETER, MANHOLES 6' DIAMETER
 PRECAST CONCRETE**

CD-602-9.1

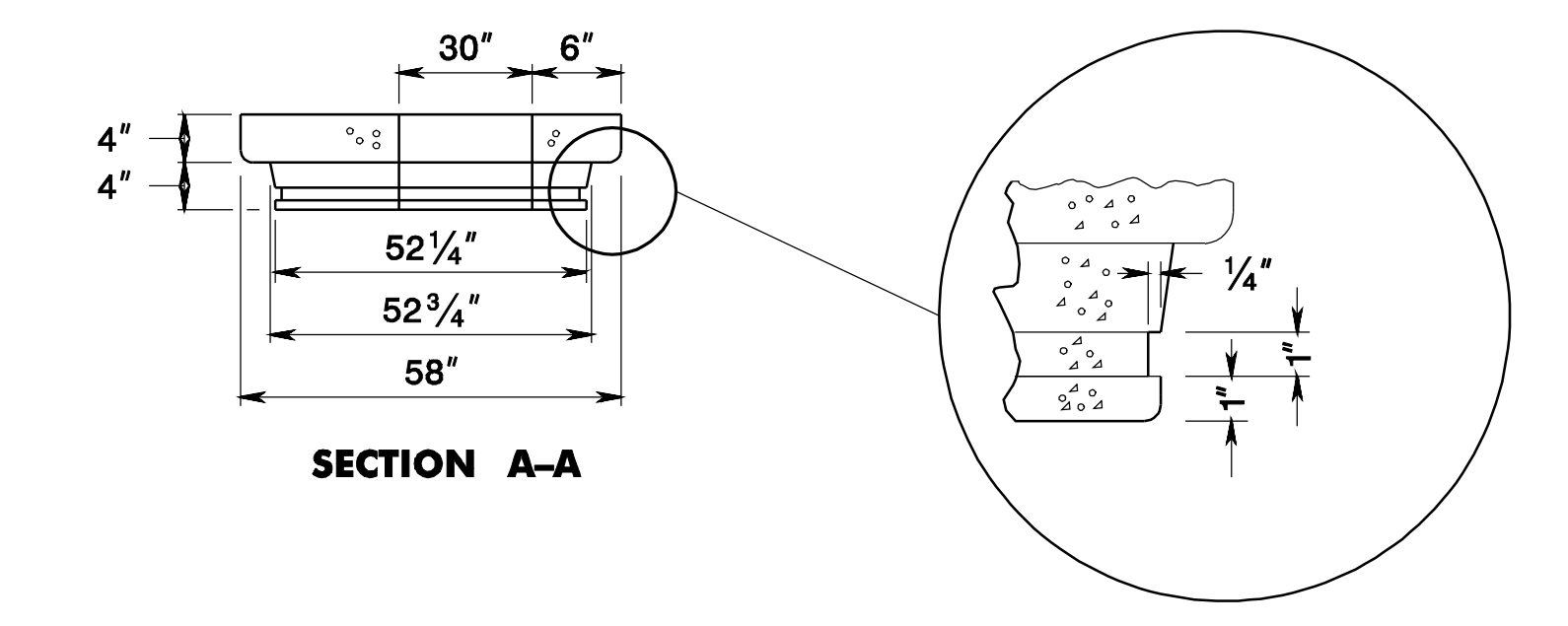

SECTION A-A

**GROOVE FOR "O" RING
 RUBBER GASKET**

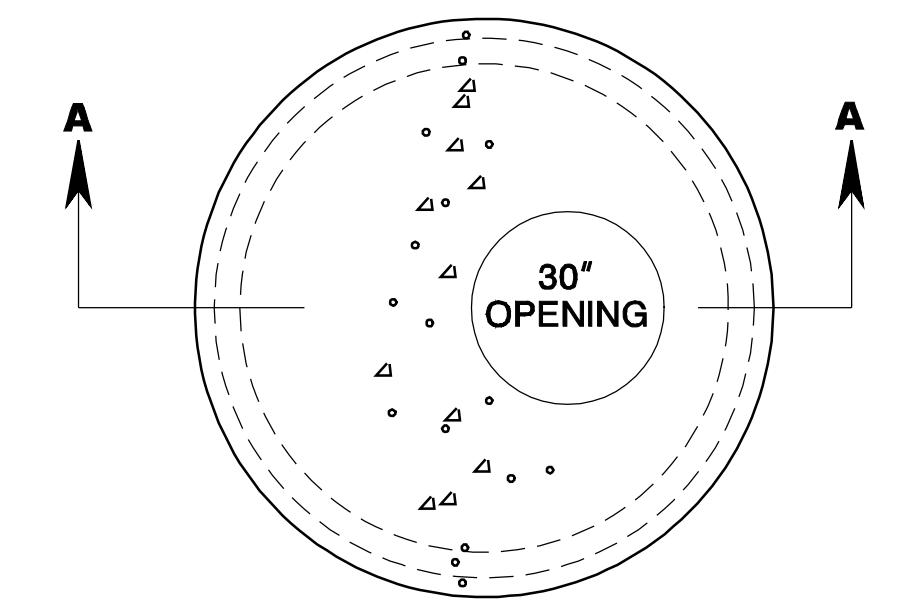

PLAN

NOTE:
 USE IN LIEU OF CONICAL SECTION WHEN
 HEIGHT OF MANHOLE IS LESS THAN 4 FEET

48" PRECAST REINFORCED CONCRETE MANHOLE FLAT TOP

CD-602-9.2

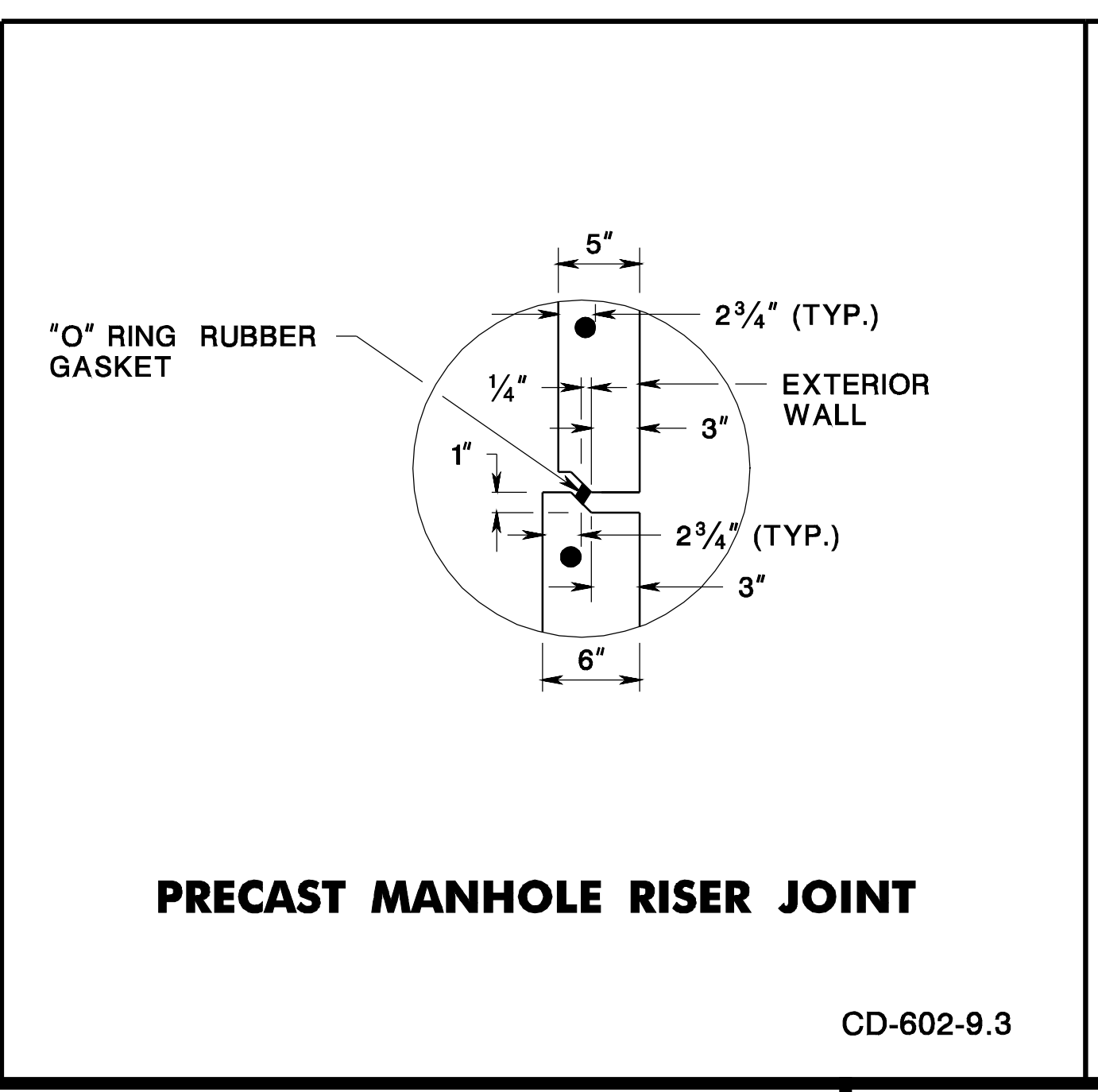

PRECAST MANHOLE RISER JOINT

CD-602-9.3

**PRECAST MANHOLES
 N.T.S.**

CD-602-9
 NEW JERSEY DEPARTMENT OF TRANSPORTATION

CONSTRUCTION DETAILS