

pen table= \\N:\dotprj\pws\project\NJDOTEng\Plot\TBLs\Roadway\basic.tbl  
scale= 30.0000000:1.0000000  
date= 17-DEC-2007 09:45  
ID= TPXBHAV  
file=

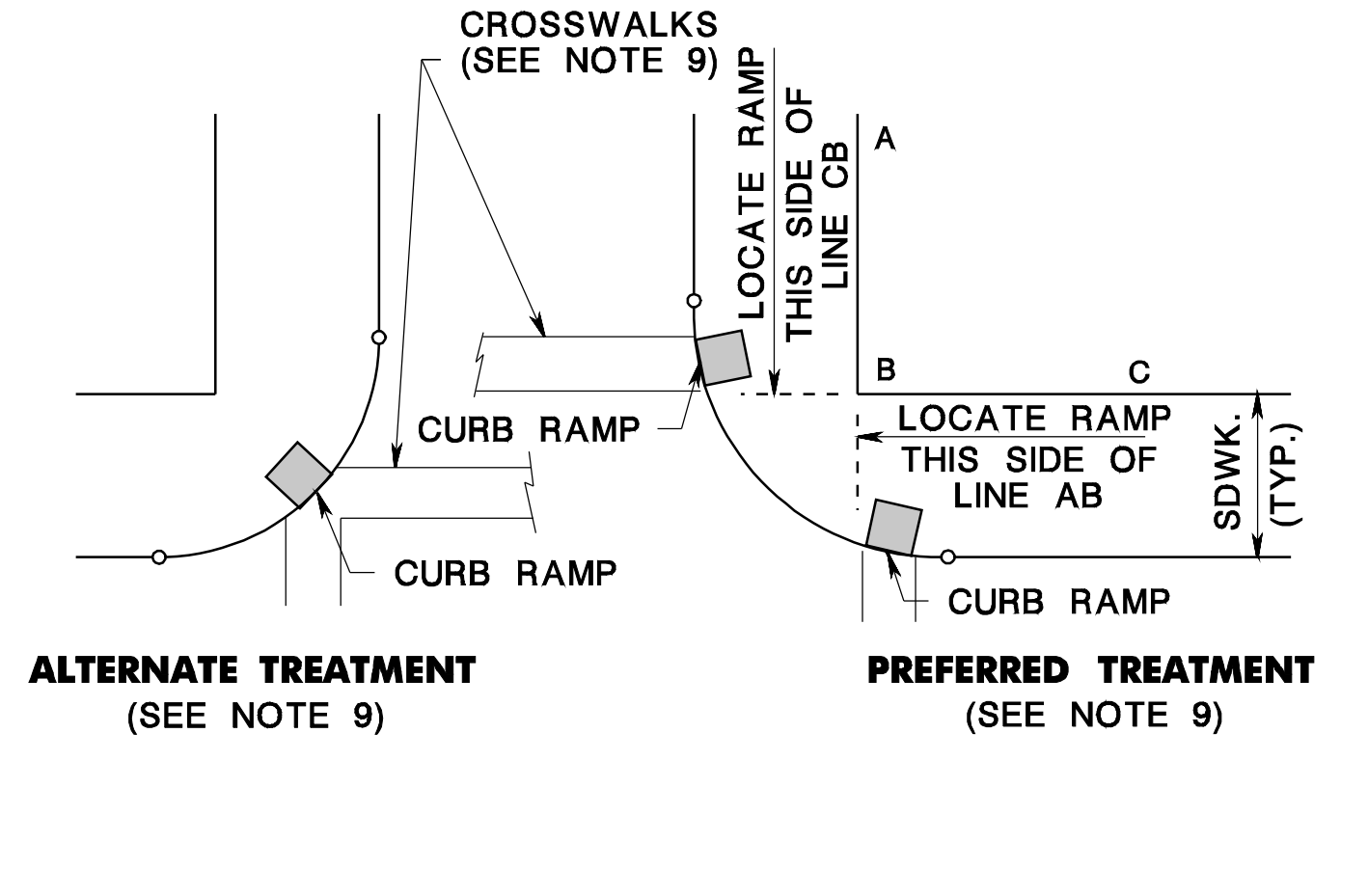
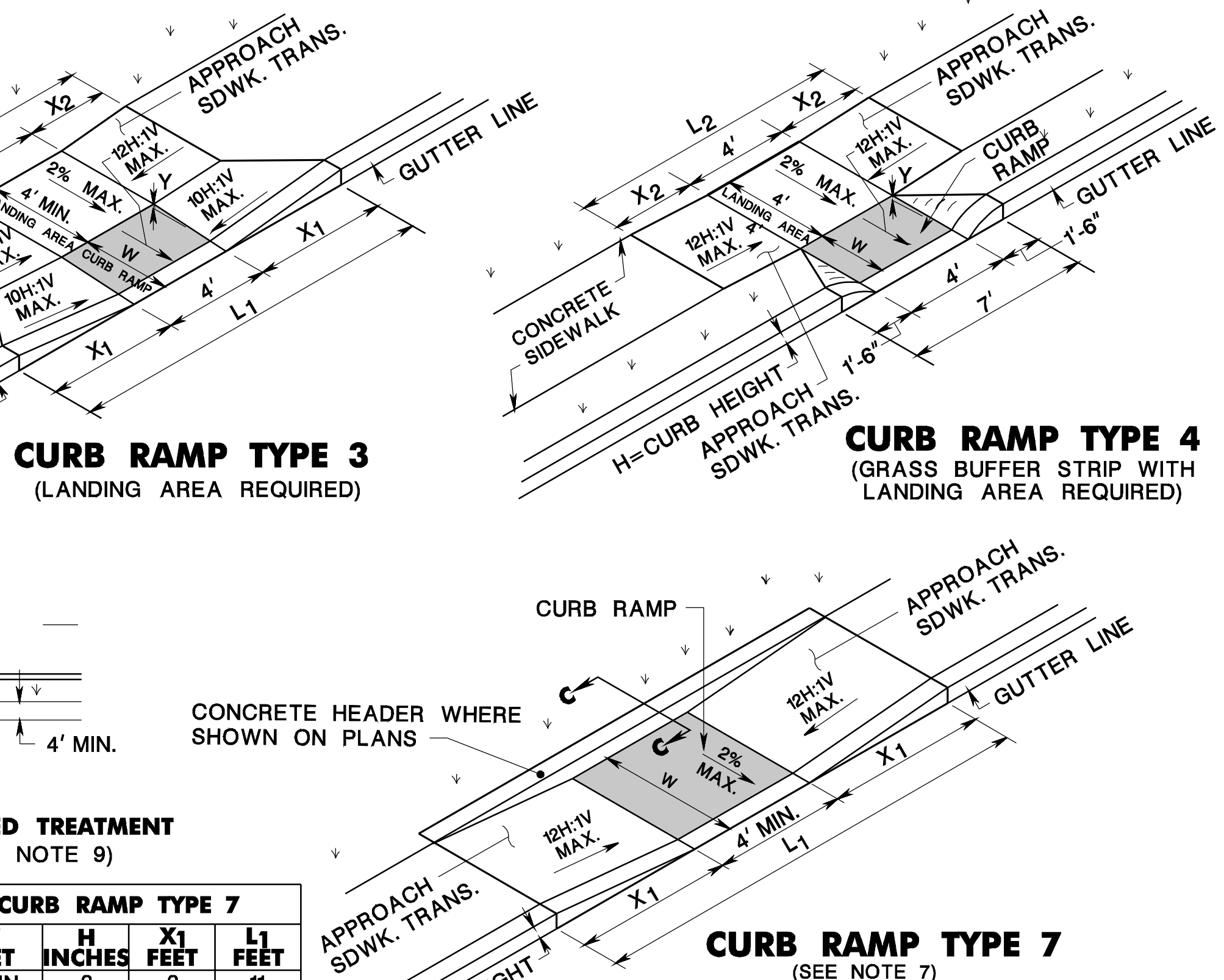
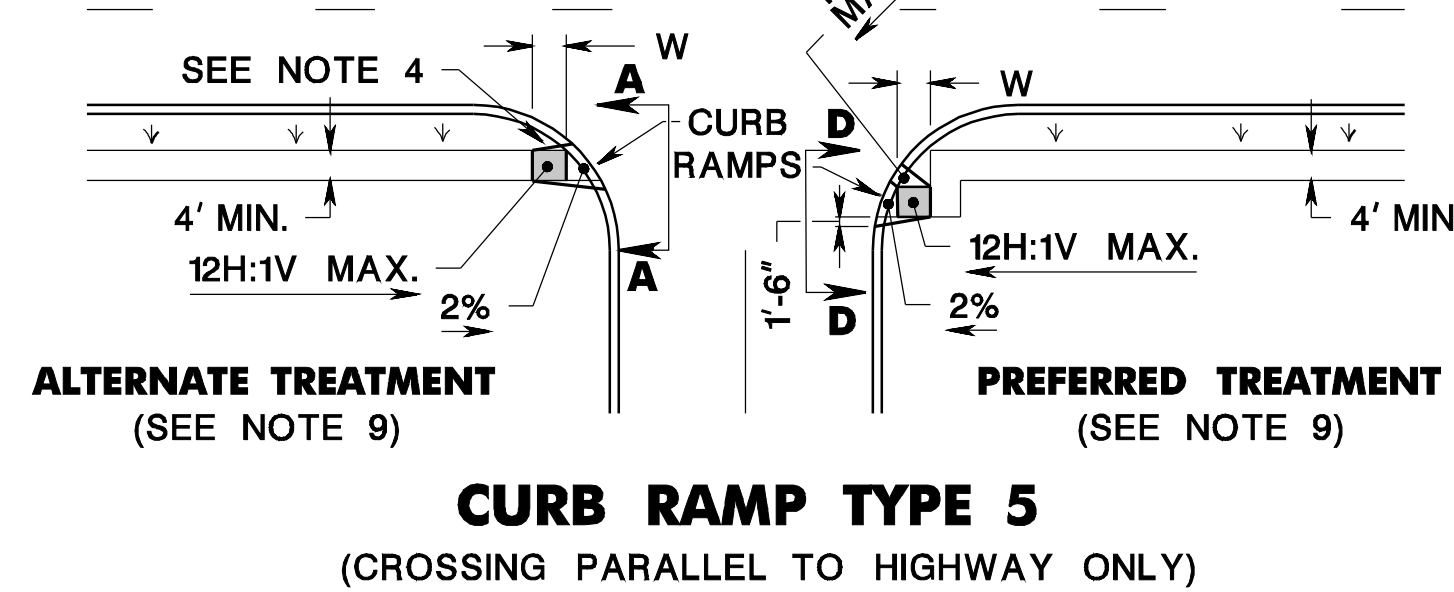
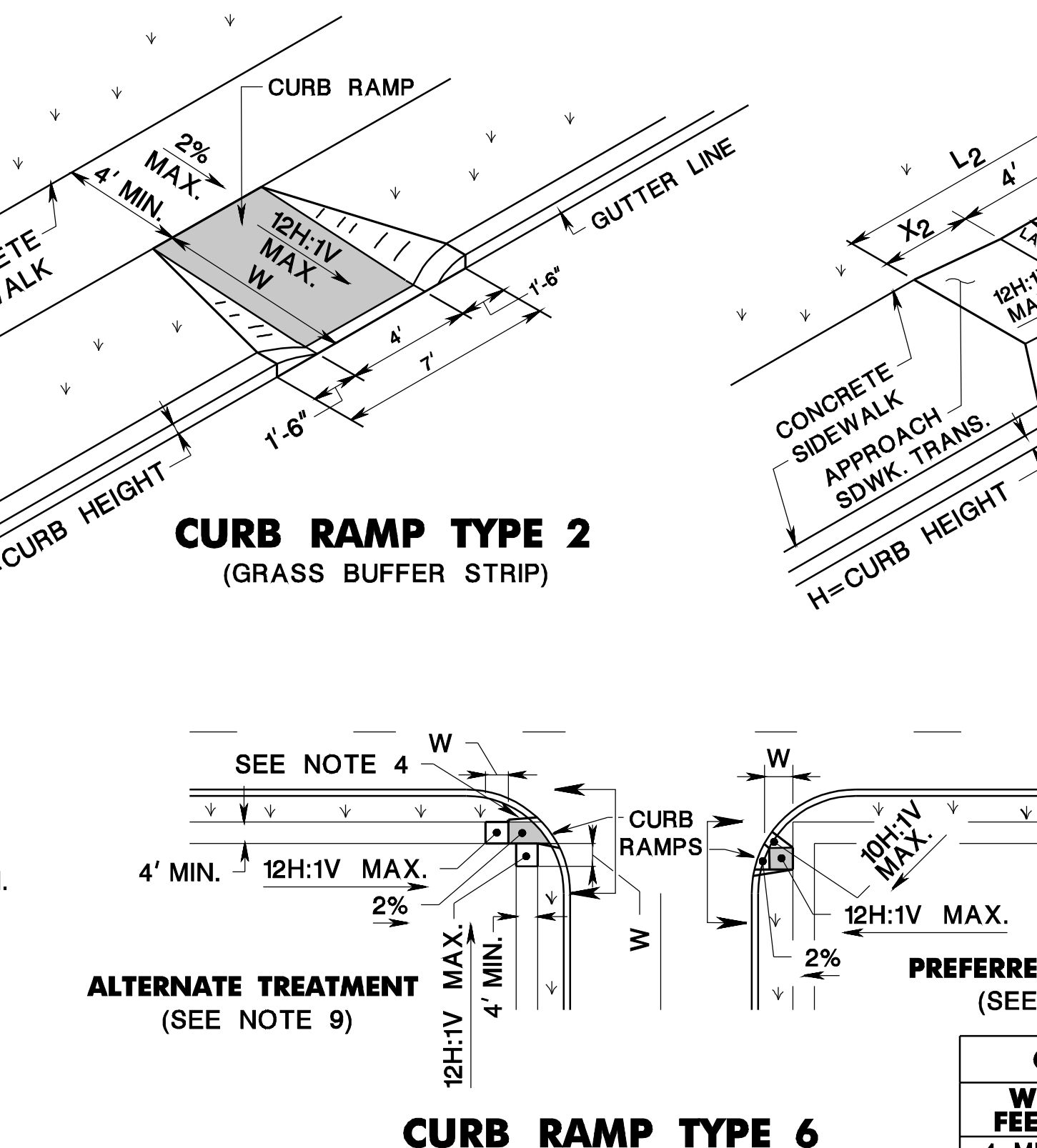
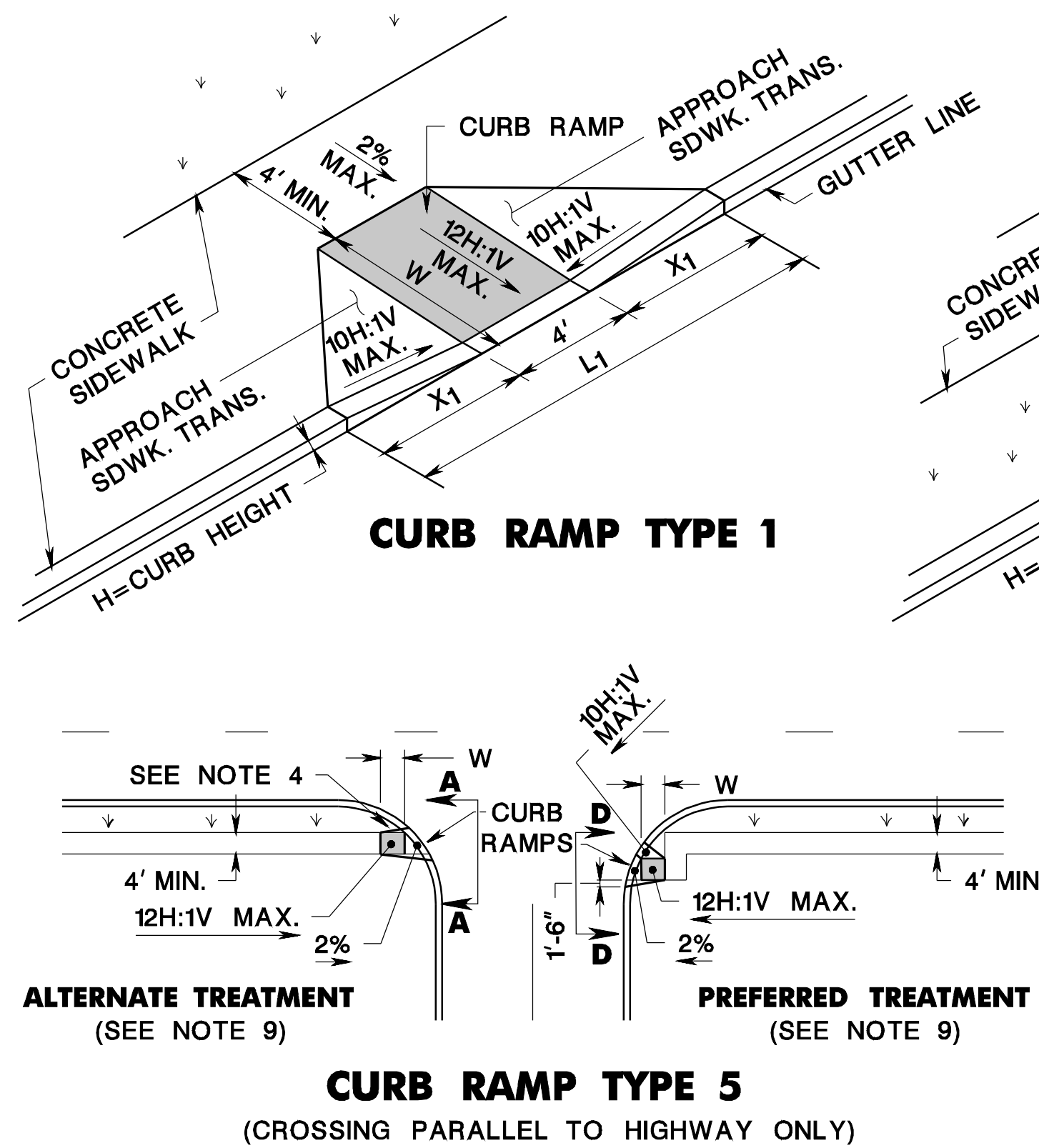
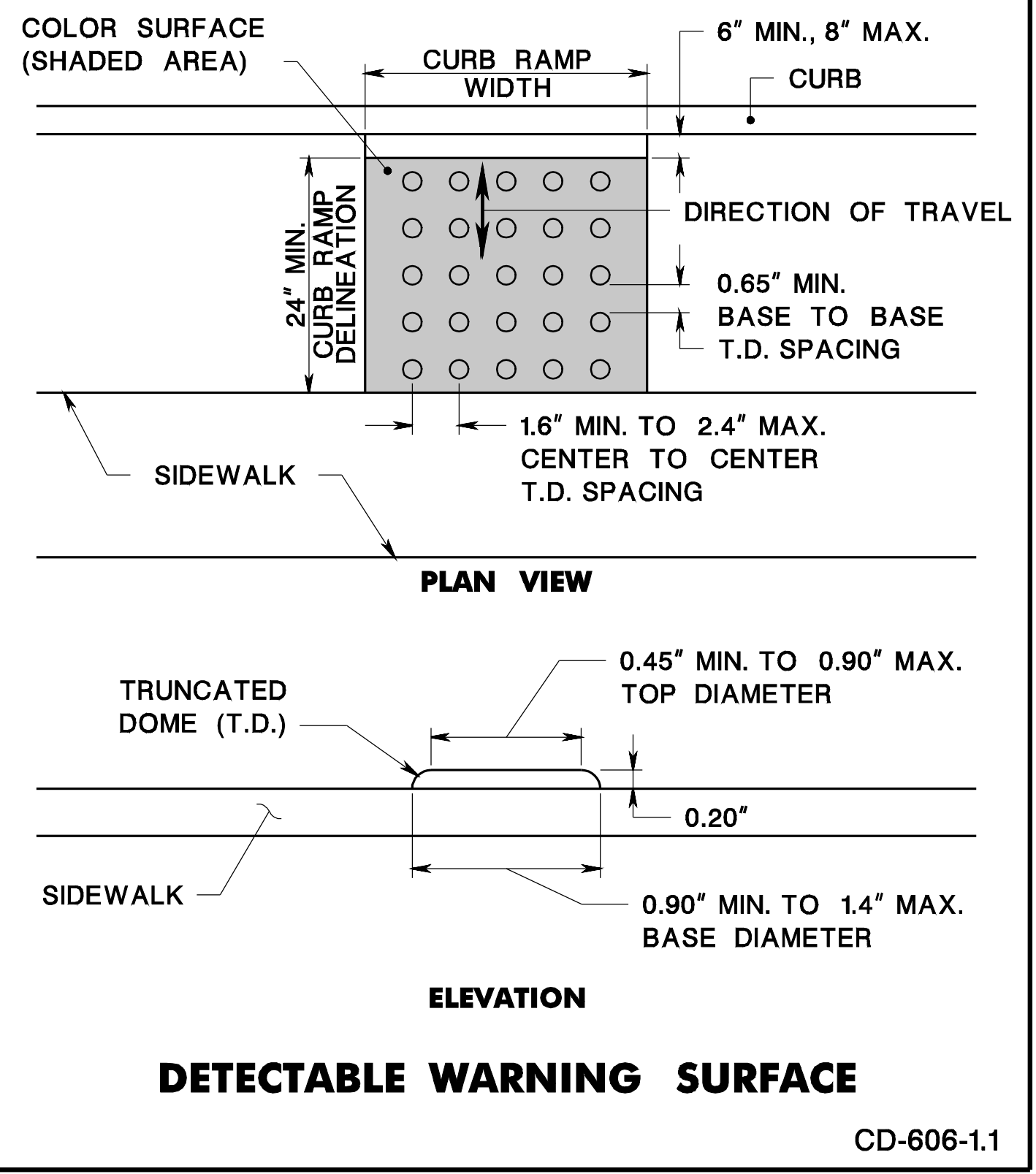

**CURB RAMP TYPE 1**

H INCHES	X1 FEET	L1 FEET	W FEET
3	2.5	9.0	3
4	3.3	10.6	4
5	4.2	12.4	5
6	5.0	14.0	6
7	5.8	15.6	7
8	6.7	17.4	8
9	7.5	19.0	9

**CURB RAMP TYPE 2, 5 OR 6**

H INCHES	W FEET
3	3
4	4
5	5
6	6
7	7
8	8
9	9

**CURB RAMP TYPE 3**

W FEET	H INCHES	X1 FEET	L1 FEET	Y INCHES	X2 FEET	L2 FEET
2.5	3	2.5	9	2.5	0.5	5
	4	3.3	10.6	2.5	1.5	7
	5	4.2	12.4	2.5	2.5	9
	6	5.0	14.0	2.5	3.5	11
	7	5.8	15.6	2.5	4.5	13
	8	6.7	17.4	2.5	5.5	15
	9	7.5	19.0	2.5	6.5	17
3.0	3	*	*	*	*	*
	4	3.3	10.6	3.0	1	6
	5	4.2	12.4	3.0	2	8
	6	5.0	14.0	3.0	3	10
	7	5.8	15.6	3.0	4	12
	8	6.7	17.4	3.0	5	14
	9	7.5	19.0	3.0	6	16
3.5	3	*	*	*	*	*
	4	3.3	10.6	3.5	0.5	5
	5	4.2	12.4	3.5	1.5	7
	6	5.0	14.0	3.5	2.5	9
	7	5.8	15.6	3.5	3.5	11
	8	6.7	17.4	3.5	4.5	13
	9	7.5	19.0	3.5	5.5	15
4.0	3	*	*	*	*	*
	4	*	*	*	*	*
	5	4.2	12.4	4.0	1	6
	6	5.0	14.0	4.0	2	8
	7	5.8	15.6	4.0	3	10
	8	6.7	17.4	4.0	4	12
	9	7.5	19.0	4.0	5	14

**CURB RAMP TYPE 4**

W FEET	H INCHES	Y INCHES	X2 FEET	L2 FEET
2.5	3	2.5	0.5	5
	4	2.5	1.5	7
	5	2.5	2.5	9
	6	2.5	3.5	11
	7	2.5	4.5	13
	8	2.5	5.5	15
	9	2.5	6.5	17
3.0	3	**	**	**
	4	3.0	1	6
	5	3.0	2	8
	6	3.0	3	10
	7	3.0	4	12
	8	3.0	5	14
	9	3.0	6	16
3.5	3	**	**	**
	4	3.5	0.5	5
	5	3.5	1.5	7
	6	3.5	2.5	9
	7	3.5	3.5	11
	8	3.5	4.5	13
	9	3.5	5.5	15
4.0	3	**	**	**
	4	**	**	**
	5	4.0	1	6
	6	4.0	2	8
	7	4.0	3	10
	8	4.0	4	12
	9	4.0	5	14

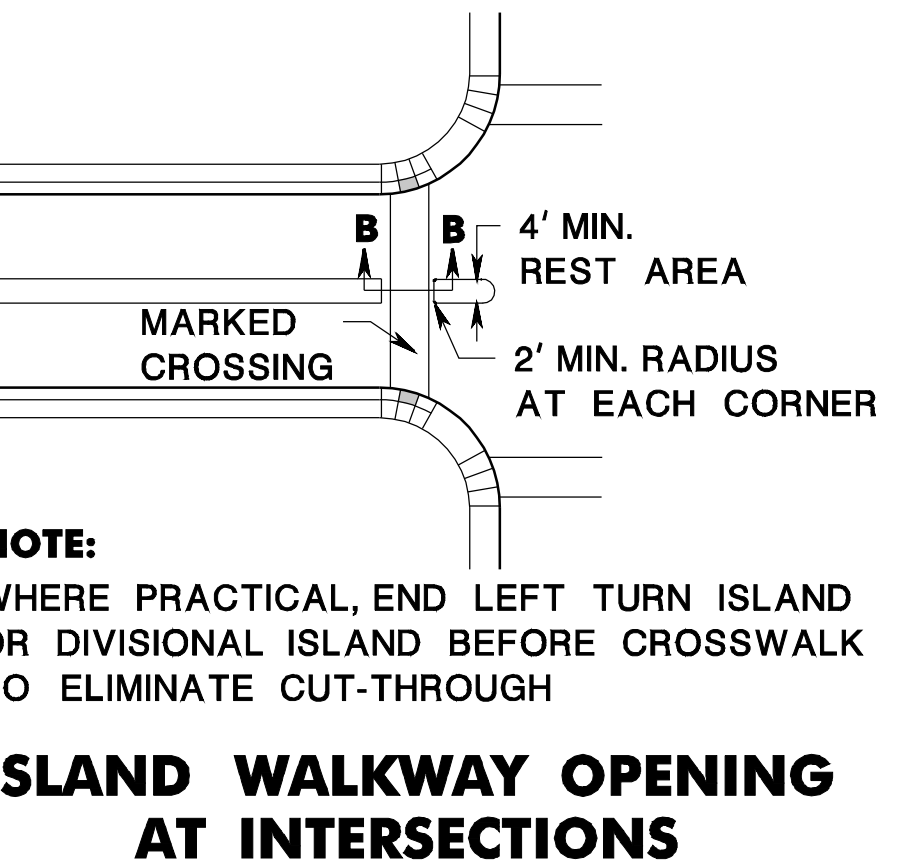

- LANDING AREA, APPROACH SIDEWALK TRANSITIONS, AND CURB RAMP SHALL BE KEPT CLEAR OF OBSTRUCTIONS.
- DIMENSIONS SHOWN IN TABLES ARE FOR RELATIVELY FLAT SIDEWALK AREAS. CARE SHOULD BE TAKEN WHEN DETERMINING CURB RAMP SIZE BASED ON CURB HEIGHT (H) WHERE ELEVATION OF CURB AND SIDEWALK VARY DRASTICALLY IN AREA OF PROPOSED CURB RAMP.
- CURB (DROPPED CURB) GUTTERLINE TO BE FLUSH WITH ROADWAY PAVEMENT A MINIMUM OF 4 FEET AT ALL CURB RAMP.
- FOR CURB RAMP TYPES 5 AND 6, IF A GRASS BUFFER DOES NOT EXIST, SLOPE CURB TO EQUAL SLOPE OF ADJACENT CURB RAMP.
- SIDEWALK AND CURB RAMP WITHIN AREA ENCLOSED BY HEAVY LINES TO BE PAID FOR AS CONCRETE SIDEWALK OF THE APPROPRIATE ADJACENT THICKNESS.
- CURB AND HEADER WITHIN AREA ENCLOSED BY HEAVY LINES TO BE PAID FOR AS VERTICAL CURB OR SLOPING CURB OF THE APPROPRIATE ADJACENT SIZE AND KIND.
- WHERE THE DISTANCE FROM THE GUTTER LINE TO THE OUTSIDE EDGE OF SIDEWALK IS 6 FEET OR LESS, CURB RAMP TYPE 7 SHOULD BE USED, INSTEAD OF CURB RAMP TYPE 1 THROUGH 4.
- CROSSWALKS AND STOP LINES MAY BE MARKED OR UNMARKED, SEE PLANS.
- PREFERRED AND ALTERNATE TREATMENTS SHOULD NOT BE INTERMIXED WITHIN THE SAME INTERSECTION.
- DIMENSIONS SHOWN IN TABLES ARE FOR 3 INCH TO 9 INCH CURB HEIGHTS. WHERE THE CURB HEIGHTS ARE OTHER THAN WHAT IS PROVIDED IN THE TABLES, THE DIMENSIONS OF THE RAMPS WILL HAVE TO BE CALCULATED BASED ON CROSS SLOPES SHOWN.

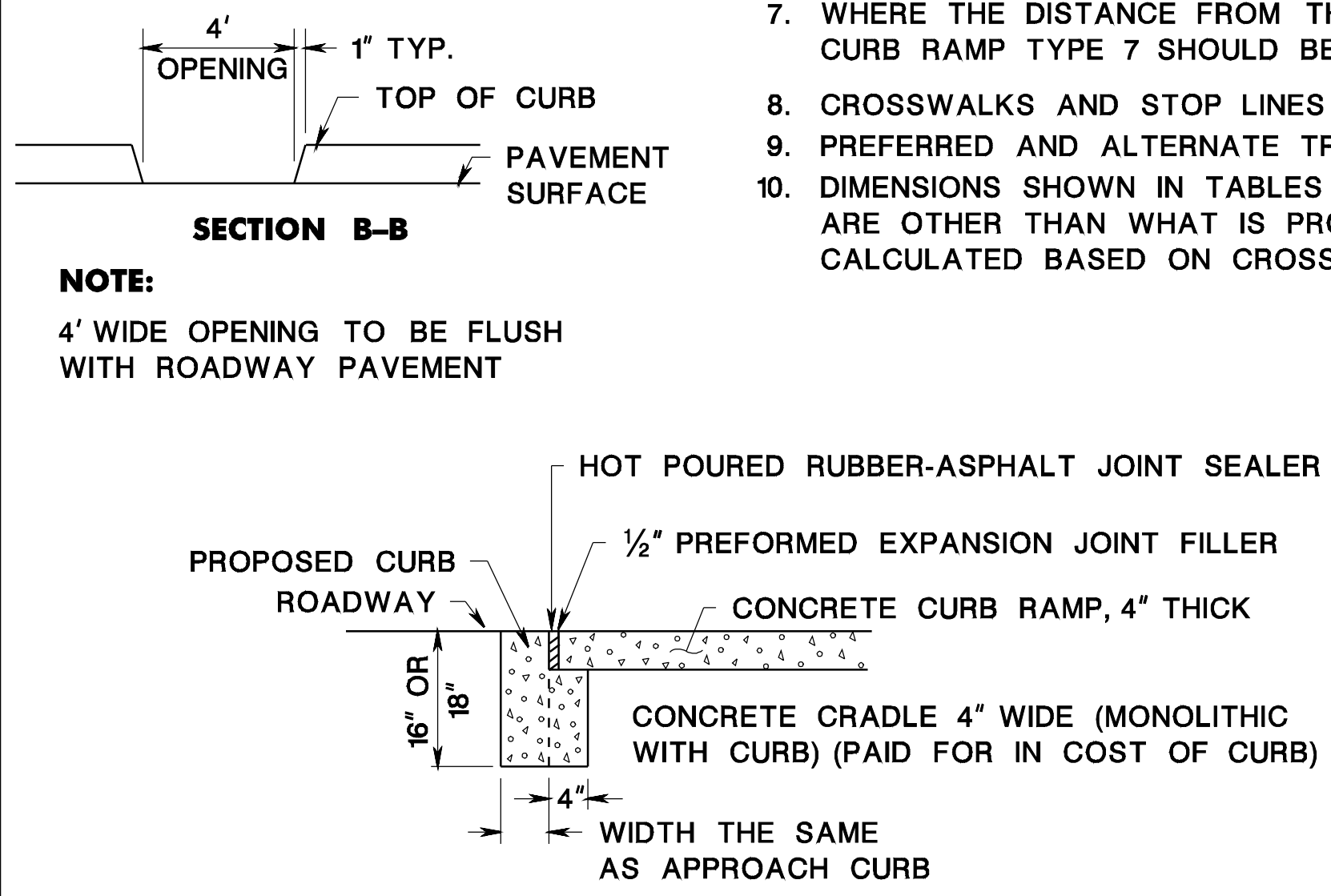
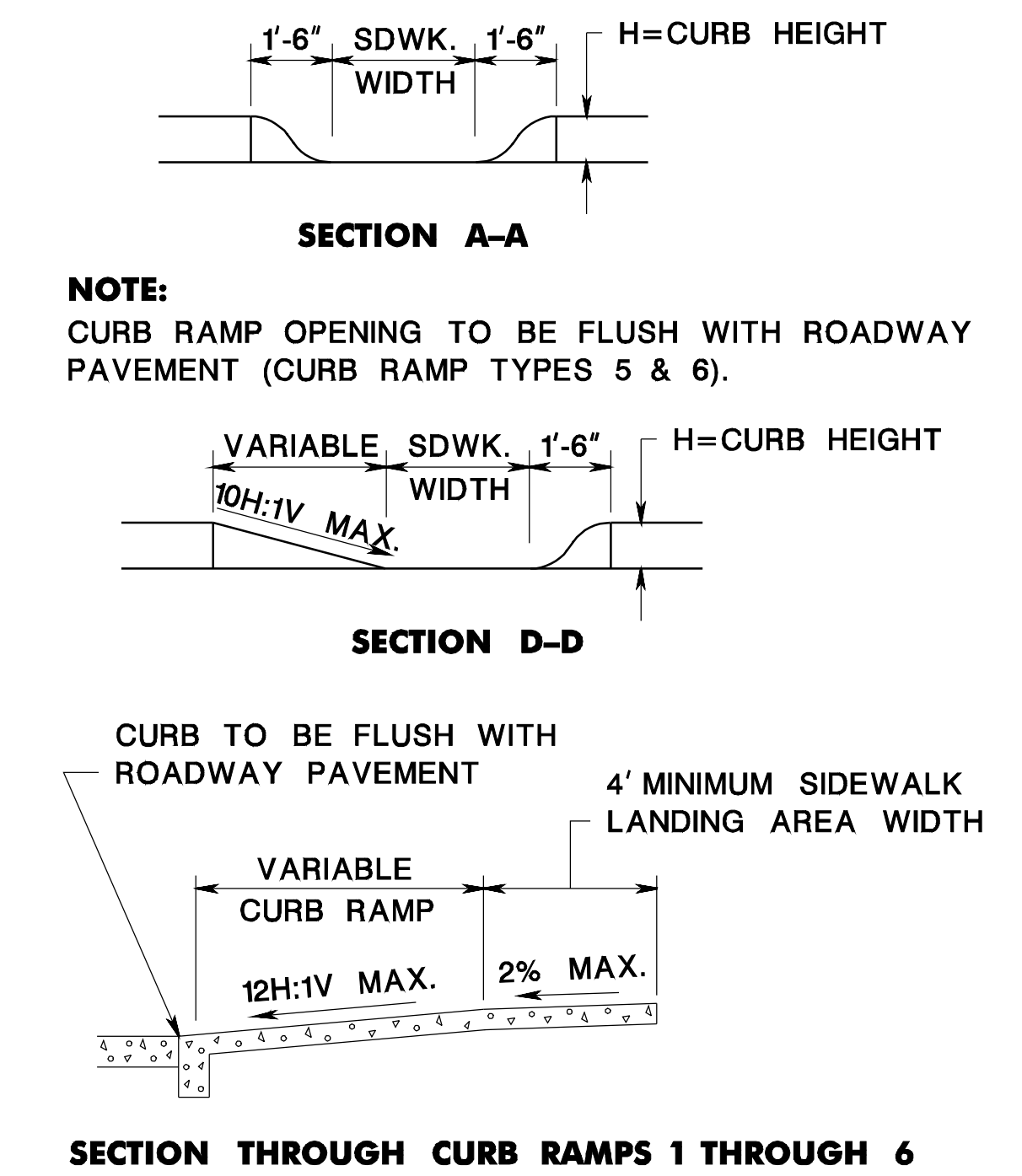

**PUBLIC SIDEWALK CURB RAMP DETECTABLE WARNING SURFACE**  
N.T.S.  
HMA = HOT MIX ASPHALT  
CD-606-1  
NEW JERSEY DEPARTMENT OF TRANSPORTATION

**CONSTRUCTION DETAILS**

**CURB RAMPS**

CD-606-1.2