

SITE LOCATION CHART

TOC N/S	JOB SITE	PLAN SHEET	ROUTE AND INTERSECTION	MUNICIPALITY	COUNTY	DEVICE	TYPE	COMMUNICATIONS
N	*	ITS-*	ROUTE 78 EB M.P. 28.6	BEDMINSTER TOWNSHIP	SOMERSET	DMS	FRONT ACCESS 27' X 80'	WIRELESS
N	*	ITS-*	ROUTE 78 EB M.P. 34.7	BEDMINSTER TOWNSHIP	SOMERSET	DMS	FRONT ACCESS 27' X 70'	WIRELESS
N	*	ITS-*	ROUTE 287 SB M.P. 23.68	FAR HILLS BOROUGH	SOMERSET	CAMERA	DOME	FIBEROPTIC
N	*	ITS-*	ROUTE 287 NB PRIOR TO EXIT 90 M.P. 28.2	BERNARDS TOWNSHIP	SOMERSET	DMS	WALK-IN 27' X 80'	FIBEROPTIC
N	*	ITS-*	ROUTE 287 AT NORTH MAPLE AVE.	BERNARDS TOWNSHIP	SOMERSET	CAMERA	DOME	FIBEROPTIC
N	*	ITS-*	ROUTE 287 AT MT. AIRY ROAD	BERNARDS TOWNSHIP	SOMERSET	CAMERA	DOME	DSL
N	*	ITS-*	ROUTE 287 FROM M.P. 21	BEDMINSTER TOWNSHIP	SOMERSET	HUB	N/A	FIBEROPTIC
N	*	ITS-*	ROUTE 287/ROUTE 78 HAR	BEDMINSTER TOWNSHIP	SOMERSET	HAR	N/A	FIBEROPTIC
N	*	ITS-*	ROUTE 287 AND ROUTE 10	HANOVER TOWNSHIP	MORRIS	CAMERA	POSITIONAL	BROAD BAND CABLE

GENERAL CONSTRUCTION NOTES

1. STATIONS ARE APPROXIMATE AND ARE FOR INFORMATIONAL PURPOSES ONLY.
2. ENSURE THAT THE MINIMUM DISTANCE SPECIFIED BY THE UTILITY OWNER IS MAINTAINED BETWEEN ALL EXISTING UNDERGROUND UTILITIES AND ALL PROPOSED UNDERGROUND.
3. COMPLETE GUIDE RAIL INSTALLATIONS AND UPGRADES PRIOR TO INSTALLING ABOVE GROUND ITS FACILITIES.
4. CONTACT TRAFFIC OPERATIONS FOR MARK OUT OF EXISTING ITS UNDERGROUND WIRES AND CABLES.

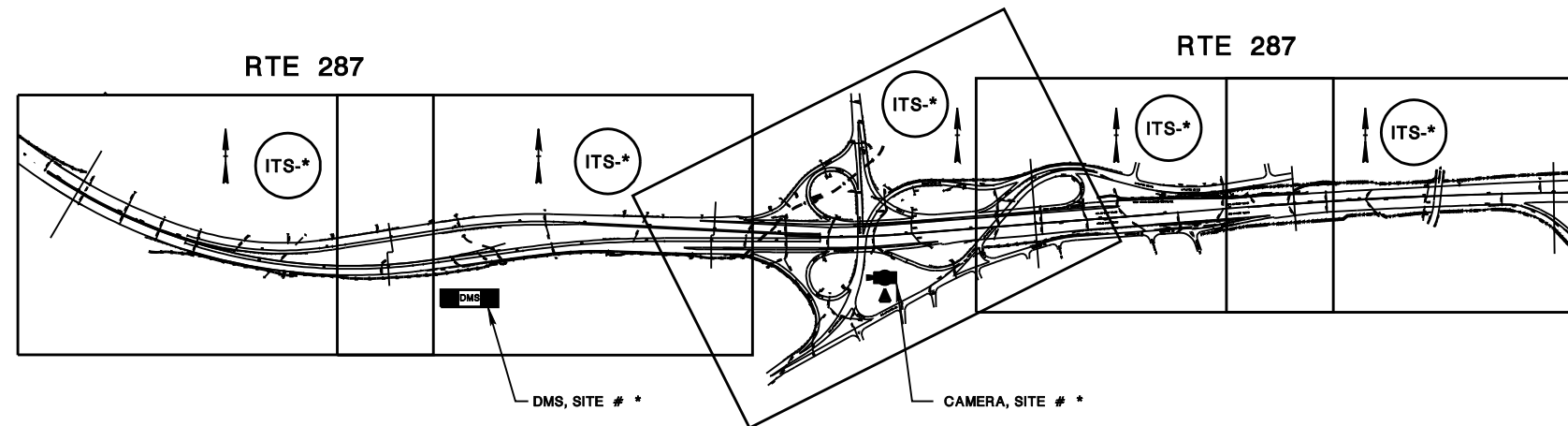

LEGEND OF SYMBOLS AND NOTATIONS

EXISTING	PROPOSED	
		JUNCTION BOX ITS
		CAMERA (WITH BLIND SPOT)
		HIGHWAY ADVISORY RADIO ANTENNA
		HAR SIGN
		DMS
		TRAVEL TIME SYSTEM
		ITS WIRES & CABLES
		CONTROLLER CABINET W/SIDEWALK
		18' X 36' JUNCTION BOX
		METER CABINET
		CONTROLLER
		IMAGE DETECTOR
		GRID PAVERS



NEW JERSEY DEPARTMENT OF TRANSPORTATION

ITS LOCATION PLAN

ROUTE *

CONTRACT NO. *

Individual, Firm, Partnership, etc.
(signature) (date)
Name
N.J.P.E. LIC. NO. *

NEW JERSEY DEPARTMENT OF TRANSPORTATION
 PROJECT NO. 15-00000000
 DRAWING NO. ITS-001
 DATE: 08/11/15

STATE FEDERAL PROJECT NO.
N.J. *

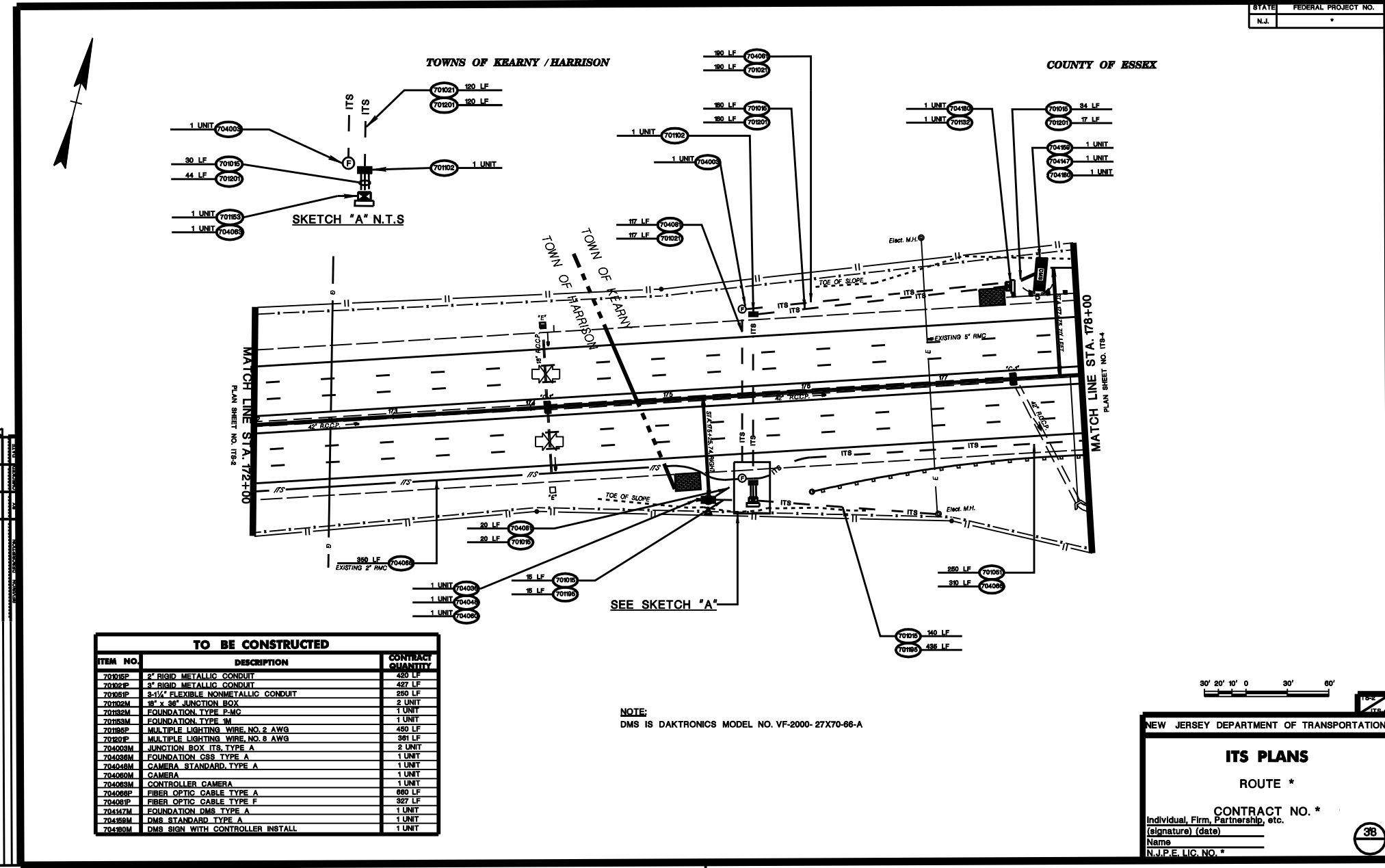

SKETCH "A" N.T.S.

SEE SKETCH "A"

ITEM NO.	DESCRIPTION	CONTRACT QUANTITY
704085P	2" RIGID METALLIC CONDUIT	450 LF
704082P	2" RIGID METALLIC CONDUIT	427 LF
704081P	3-1/2" FLEXIBLE NONMETALLIC CONDUIT	250 LF
704082M	38" x 36" JUNCTION BOX	2 UNIT
704082M	FOUNDATION TYPE P-MC	1 UNIT
704083M	FOUNDATION TYPE M	1 UNIT
704083P	MULTIPLE LIGHTING WIRE, NO. 2 AWG	450 LF
704081P	MULTIPLE LIGHTING WIRE, NO. 8 AWG	381 LF
704003M	JUNCTION BOX ITS, TYPE A	2 UNIT
704083M	FOUNDATION CRS TYPE A	1 UNIT
704084M	CAMERA, STANDARD, TYPE A	1 UNIT
704083M	CAMERA	1 UNIT
704083M	CONTROLLER CAMERA	1 UNIT
704088P	FIBER OPTIC CABLE TYPE A	660 LF
704089P	FIBER OPTIC CABLE TYPE F	327 LF
704087M	FOUNDATION DMS, TYPE A	1 UNIT
704086M	DMS STANDARD TYPE A	1 UNIT
704080M	DMS SIGN WITH CONTROLLER INSTALL	1 UNIT

NOTE:
DMS IS DAKTRONICS MODEL NO. VF-2000-27X70-66-A



NEW JERSEY DEPARTMENT OF TRANSPORTATION

ITS PLANS

ROUTE *

CONTRACT NO. *

Individual, Firm, Partnership, etc.
(signature) (date)

Name _____

N.J.P.E. LIC. NO. *

38

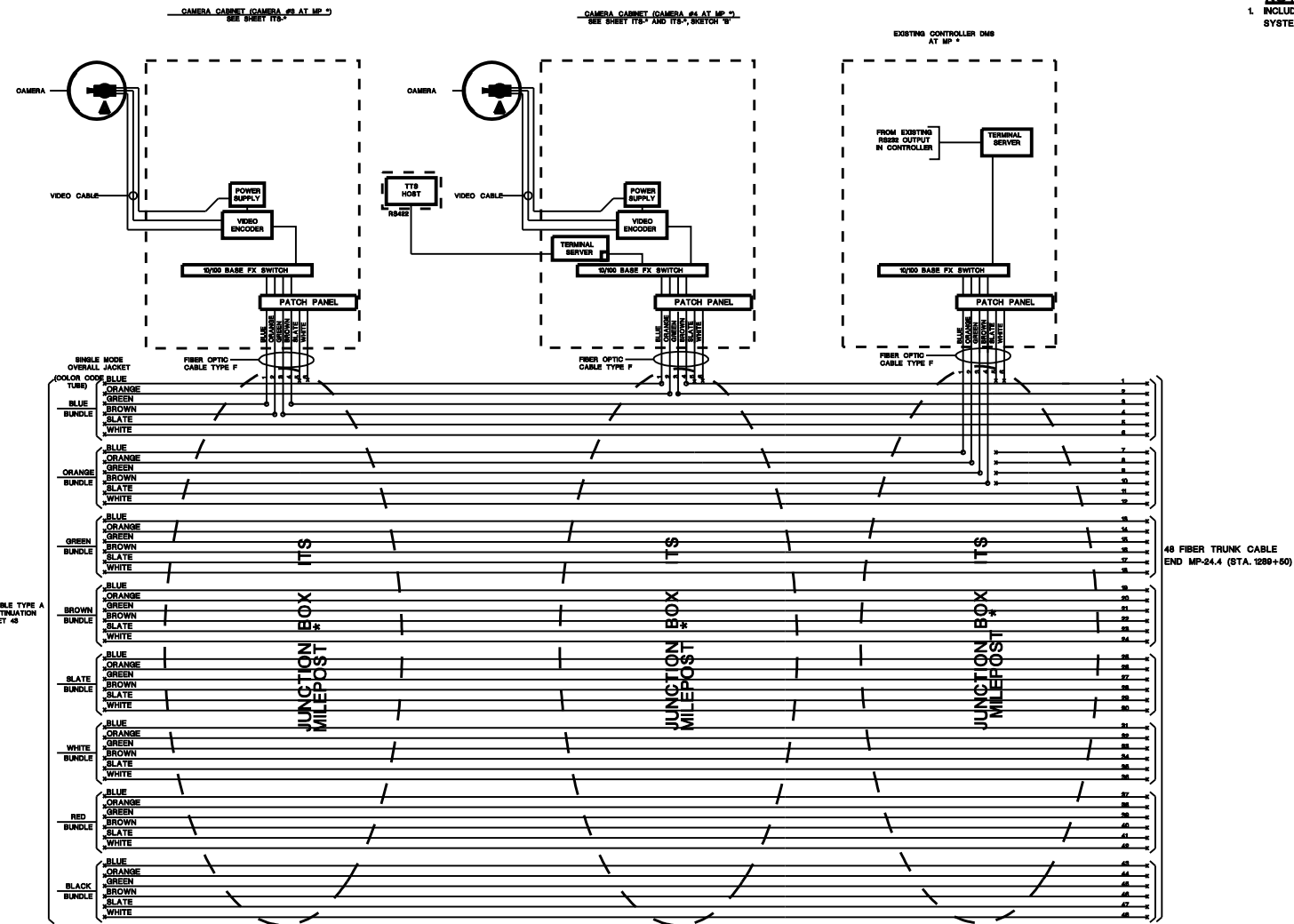

NOTE:
1. INCLUDE TEMPORARY COMMUNICATIONS ARRANGEMENTS IN THE SYSTEM WORKING DRAWING SUBMITTAL.

FIBER OPTIC CABLE INTERCONNECTIONS
N.T.S.

NEW JERSEY DEPARTMENT OF TRANSPORTATION

**FIBER SYSTEM BLOCK
DIAGRAM**

ROUTE *

CONTRACT NO. *

Individual, Firm, Partnership, etc.
Signature (date)
Name
NJPE LIC. NO. *

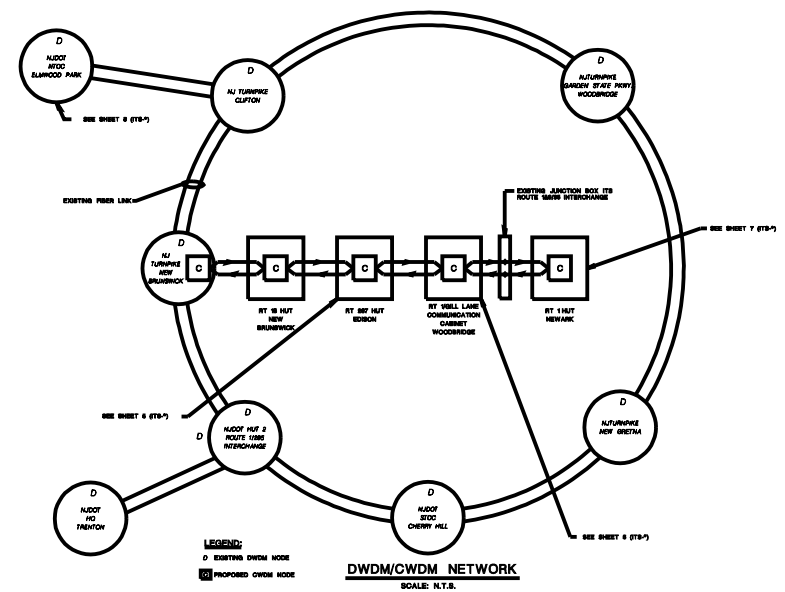
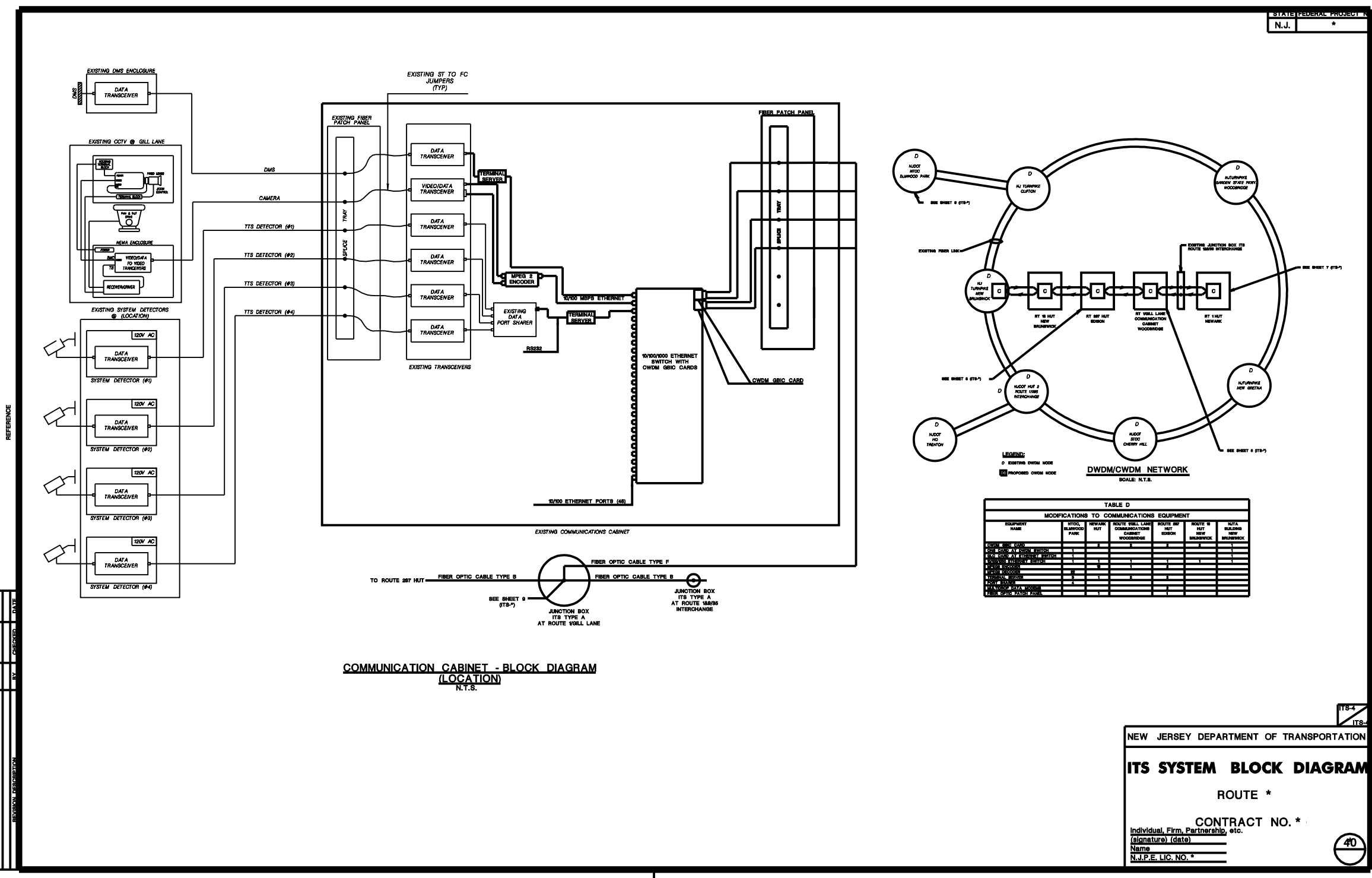

TABLE D
MODIFICATIONS TO COMMUNICATIONS EQUIPMENT

EQUIPMENT NAME	ITSD	NEWARK	ROUTE VELL LANE COMMUNICATIONS CABINET	ROUTE 307 HWT BOCH	ROUTE 141T NEWARK	ALTA DELMONTE NEW BRUNSWICK
10/100/1000 ETHERNET SWITCH WITH CWDM SBC CARDS						
DATA TRANSCEIVER						
SYSTEM DETECTOR (#1-4)						
VIDEO/DATA TO VIDEO TRANSDUCER						
AC/DC CONVERTER						
EXISTING DATA PORT SHARER						
TERMINAL SERVERS						
EXISTING TRANSCEIVERS						
10/100 ETHERNET PORTS (48)						
EXISTING FIBER TRAY						
SPLICE						
EXISTING FIBER PATCH PANEL						

NEW JERSEY DEPARTMENT OF TRANSPORTATION
ITS-4
ITS-

ITS SYSTEM BLOCK DIAGRAM
ROUTE *

CONTRACT NO. *
Individual, Firm, Partnership, etc.
(signature) (date)
Name
N.J.P.E. LIC. NO. *

40