

# NEW JERSEY TRANSIT CORPORATION

## NOTICE TO CONTRACTORS

### OBSERVER HIGHWAY SWITCHING HOUSE - HOBOKEN TERMINAL INVITATION FOR BID NO. 16-042X

Notice is hereby given that this is an electronic bid submission. Electronic bids will be received NJ TRANSIT via the Internet until 2:00 pm, Tuesday, May 9, 2017, for the Observer Highway Switching House – Hoboken Terminal.

Bids for the project will be downloaded from the Bid Express website on the scheduled Bid Due Date (subject to change by Addenda) at 2:00 pm, Tuesday, May 9, 2017 and publicly opened and read immediately thereafter at NJ TRANSIT's offices located at One Penn Plaza East, 6th Floor, Bid Room, Newark, New Jersey 07105. The Bidder must upload its bid prior to the hour named so that it is included in the project download. Late bids cannot be accepted. This is the only way to submit a bid for this project; paper bids will not be accepted.

The work under this Invitation for Bid consists of the construction of new switch house and RTU facilities located on a common, elevated steel platform. The electrical feed to the Hoboken "Depot" Substation must remain in continuous operation throughout the project, and the new Observer Highway Switching House must be installed, tested and energized prior to disconnecting any loads from the existing service feeds/equipment.

In order to obtain all pertinent Bid Documents, interested firms must register with BID EXPRESS at <https://www.bidx.com>. Contractors that are currently registered with BID EXPRESS to bid NJDOT or any other public construction project do not require further registration, only an additional digital ID. To subscribe, follow instructions on the website. Fees apply to downloading documents and plans and bidding access. The fee schedule is available on the website. All fees are directly payable to Bid Express.

All firms must be prequalified by NJ TRANSIT prior to submitting a bid. Contractors must be prequalified for Building Construction – Rail (BR) in a classification of GC – General Contractor and for an amount of work that is equal to or greater than their bid amount. NJ TRANSIT suggests a minimum rating amount of "I", \$1,000,001 to \$2,000,000. Prequalification questionnaires are available for download from the Bid Express website [www.bidx.com](http://www.bidx.com). Contractors who are not currently prequalified as required above or whose prequalification has expired **should** submit completed prequalification forms to NJ TRANSIT's Bid Desk no later than seven (7) calendar days after the scheduled Pre-Bid Meeting date. Late submissions **may not** be considered for this solicitation.

A pre-bid conference has been scheduled for 2:00 p.m., Monday, April 3, 2017. The pre-bid conference will be held at NJ TRANSIT headquarters located at One Penn Plaza East, Newark, NJ 07105.

A site visit has been scheduled for 11:00 a.m., Wednesday, April 5, 2017. The site visit will be held at the Observer Highway Switching House, Hoboken Terminal, Hoboken, NJ. Contractors are advised that a NJ TRANSIT escort is necessary while present on non-public areas of NJ TRANSIT property. Contractors must bring and wear their own safety apparatus including hard hats, reflective vests and hard toed shoes/boots in order to go on the site visit. Unauthorized/unescorted entry onto the railroad right-of-way is strictly prohibited. Bidders are advised that attendance at both the pre-bid conference and site visit is strongly recommended.

Contractors and subcontractors are also required to comply with the State of New Jersey, Division of Revenue Business Registration Certificate requirements (P.L. 2004, c.57). Contractors or Subcontractors shall not engage in the performance of any work, unless the Contractor or Subcontractor is registered with the New Jersey Department of Labor and Department of Treasury Division of Revenue, as required. In addition, Source Disclosure Requirements (N.J.S.A. 52:34-13.2) apply to this project.

Bidders are required to comply with the requirements of N.J.S.A. 10:5-31 et seq. and N.J.A.C. 17:27, regarding Equal Employment Opportunity Laws and Regulations. Disadvantaged Business Enterprises, in accordance with the Department of Transportation (DOT) Regulations 49 CFR, Part 26, shall have the maximum opportunity to participate in the performance of this contract. A race conscious thirteen percent (13%) DBE goal has been set for this project.

In accordance with N.J.S.A. 27:25-11(b) (3) and N.J.A.C. 16:72-2.2 bidders are notified that a bid bond in the amount of 10% of the bid price is required with their bids.

This project is subject to the requirements of the Public Works Contractor Registration Act, N.J.S.A. 34:11-56.48 et seq. and the Business Registration Certificate Requirement, N.J.S.A. 52:32-44.

Chris Christie, Governor  
 Kim Guadagno, Lieutenant Governor  
 Richard T. Hammer, Commissioner  
 Steven H. Santoro, Executive Director

**TRANSIT**  
 One Penn Plaza East  
 Newark, NJ 07105-2246  
 973-491-7000

May 8, 2017

**Re: NJ TRANSIT Invitation for Bid No. 16-042X  
 Observer Highway Switching House - Hoboken Terminal  
 Addendum No. 4**

To Whom it May Concern:

The following constitutes Addendum No. 4 and must be acknowledged with each bid. Prospective bidders are advised of the following clarifications, additions and/or revisions to the above referenced Invitation for Bid. The following constitute changes that were made to the bid line items.

ALLOWANCE CHANGES				
UNITS	QTY	CURRENT	PREVIOUS	TITLE
ALW	1	\$7,045	\$8,825	Permit Fees
ALW	1	\$92,583	\$115,978	Supplemental Construction Costs
ALW	1	\$14,090	\$17,651	Laboratory Testing
ALW	1	\$17,113	\$21,564	CM Field Office and Sanitary Facilities
ALW	1	\$3,523	\$4,413	CM Field Office Furnishings and Equipment

QUANTITY CHANGES			
UNITS	CURRENT QTY	PREVIOUS QTY	TITLE
Tons	461	2828	Contaminated Soil Disposal - ID27

<b>QUANTITY CHANGES</b>			
<b>UNITS</b>	<b>CURRENT QTY</b>	<b>PREVIOUS QTY</b>	<b>TITLE</b>
Tons	61	(previously was an allowance bid item)	Contaminated Soil Disposal - Hazardous
CY	592	2155	Excavation
Tons	15.23	15.00	Structural Steel
LS	1	10 LF	Drilled Shaft in Soil 42" Diameter

<b>MISCELLANEOUS CHANGES</b>			
<b>UNITS</b>	<b>CURRENT QTY</b>	<b>CHANGE</b>	<b>TITLE</b>
SY	180	New Item	Dense-Graded Aggregate Base Course, 4" Thick
LS	1	Previously Titled "Painting"	Division 9 Lump Sum – Finishes

This concludes Addendum No. 4. An authorized representative of your organization shall acknowledge receipt of this Addendum in the Exhibit provided with its bid. Failure to acknowledge receipt of all Addenda may cause the rejection of the Bid as non-responsive.

Sincerely,



Maggie Sotolongo  
Senior Contract Specialist  
Procurement Department

**Chris Christie**, Governor  
**Kim Guadagno**, Lieutenant Governor  
**Richard T. Hammer**, Commissioner  
**Steven H. Santoro**, Executive Director

**NJ TRANSIT**  
One Penn Plaza East  
Newark, NJ 07105-2246  
973-491-7000

May 5, 2017

**Re: NJ TRANSIT Invitation for Bid No. 16-042X  
Observer Highway Switching House - Hoboken Terminal  
Addendum No. 3**

To Whom it May Concern:

The following constitutes Addendum No. 3 and must be acknowledged with each bid. Prospective bidders are advised of the following clarifications, additions and/or revisions to the above referenced Invitation for Bid:

1. Attached are the responses to questions received.

This concludes Addendum No. 3. An authorized representative of your organization shall acknowledge receipt of this Addendum in the Exhibit provided with its bid. Failure to acknowledge receipt of all Addenda may cause the rejection of the Bid as non-responsive.

Sincerely,



Maggie Sotolongo  
Senior Contract Specialist  
Procurement Department

## RESPONSES TO BIDDER'S REQUEST FOR CLARIFICATIONS

1. Please correct the proposal quantity for Bid Item 180, "Drilled Shaft in Soil, 42" Diameter." The proposal quantity is 10 LF, but the detail shown on drawing C-502 (sheet 8 of 36) indicates that this shaft should be 36 LF.

**The 36.5 feet total depth of the drilled shaft includes a 5' concrete plug. The depth of the drilled shaft in the Bid Item has been revised from LF to a Lump Sum bid item. The bid price sheet has been revised to indicate a LS item, Quantity 1, to match Specification Section 02383.**

2. Plan sheet 6 shows a "Gravel Surface Section" please clarify where this gets measured and paid. In addition, please clarify the exact limits of this Gravel Surface which is only called out on plan sheet 5 but does not clearly indicate the limits.

**The Part 4 – Compensation section of Specification sections 02060 (Aggregate) and 02721 (Aggregate Base Course) have been modified to indicate how this work gets paid; and, Plan Sheet C-100 has been revised to indicate the limits of the gravel section. A Line Item for 4" DGA has been added to the Bid Price Sheet. Please see the revised Bid Price Sheet, specification sections and the revised C-100 drawing with Revision B clouds dated 05-01-17.**

3. Per plan sheet 4 it appears the existing wall is to be removed within the entire project limits. Plan sheet 5 shows only 90 ft of new curb wall being constructed. How is the grade difference supported for the +/- 100' east of the new curb wall? Also, is any rebar required in the new curb wall?

**This is correct. The entire curb wall is not being replaced so as to accommodate a proposed future project to install a new accessible pedestrian access path between Observer Highway and the Track 1 platform. The elevation difference is to be sloped as indicated on the plans and covered in aggregate. Please see the revised C-501 drawing with Revision B clouds showing the curb wall rebar dated 05-01-17.**

4. Please review the current DBE goal of 13% for this project. We have just been informed by several potential DBE electrical subcontractors, that they will not be submitting quotes on this project, and others are unresponsive. Electrical work is probably the largest subcontract value with potential DBE firms on the project. This could greatly impact the ability to achieve the DBE goal specified on the project. The other largest value of work is the specialty drilled shaft foundation items which we are unaware of registered DBE firms quoting that work. Due to the specialty drilled shafts work and the fact that, at this time, there are no DBE electrical subcontractors willing to quote our firm for this project, we

are concerned the DBE goal will not be able to be attained. Therefore, we ask you review and lower the goal for this project.

**Once the project is advertised for bid, the goal cannot be changed. There are 2 ways the Bidder can demonstrate the required Good Faith Efforts (GFE) to meet the goal:**

**1) Subcontract with certified DBE firms for values sufficient to meet the goal and submit the required formwork necessary; or**

**2) Documenting their adequate good faith efforts, which would include their submission of the required formwork, indicating detailed written explanation of all of the efforts made, and result of such efforts, along with all supporting documentation of these efforts, to allow the NJ TRANSIT Office of Business Development to review and make a determination of their Good Faith Effort.**

**If electrical work is the largest subcontract value with potential DBE firms, than the Bidder shall identify all other areas of subcontracting opportunities. (i.e. DBE Compliance Consultant, Metals, Painting, Testing, Site Work, Concrete, etc.)**

**Self-performance or price is not a valid reason to not meet a contract goal. The fact that there may be some additional costs involved in finding and using DBEs is not in itself sufficient reason for a Bidder's failure to meet the contract DBE goal.**

**Bidder shall document evidence of attempts to solicit DBE firms, calling and/or emailing once or twice in not sufficient good faith effort. Bidder must submit evidence of good faith efforts that satisfies quality, quantity, and intensity of the efforts made.**

5. In regards to the section 16951, paragraph 2.7.P: "The device shall include no-charge technical support for the life of the product". Please clarify the following: What is the mean of "device"? Does this refers to SCADA RTU cabinet?

**The term "Device" is meant to convey need for technical support of electronic based SCADA cabinet components such as the Remote I/O, HMI, Incoming Gateway, or other such components. General information for tech support related to these items must be supported by the vendor. This does not mean providing diagnostics, trouble shooting or design. It is for general help for the product.**

6. In regards to the section 16951, paragraph 2.7.P: “The device shall include no-charge technical support for the life of the product”. Please clarify the following: Please clarify the terms of “technical support”. Please identify and detail the requirements of technical support you are asking for and to be considered at no-charge for the life of the product?

**General information for tech support related to these items must be supported by the vendor. This does not mean providing diagnostics, trouble shooting or design. It is for general help for the product.**

7. Section 16951 requires a SEL-3530 RTAC for the SCADA RTU, to communicate directly with the HMI unit without any additional peripheral equipment or programs, as shown as well in the contract drawings. However, we were informed by SEL manufacturer that RTAC SEL-3530 do not have any graphics hardware, and if it has the HMI feature we would need another computer to use to connect it to view the HMI via a web browser, which seems to indicate we would need additional peripheral equipment (such as another computer) or a different SEL RTAC model than the specified in the bid documents. That said, it seems that the specified SEL-3530 and HMI do not perform the required functionalities as shown/described in the drawings and specifications. Besides, per drawing TP-05 it's shown an Ametek Panalarm #90A panel mounted annunciator, which seems to be in contradiction/conflict to what is described on section 16951 – Appendix A, in regards to the several HMI screens/displays. Please clarify.

**An HMI shall be selected to be compatible with the SEL specified equipment and shall be approved by NJ TRANSIT. The Panalarm #90A reference on Drawing TP-05 is to be deleted and replaced with specified programmable type HMI display.**

8. The HMI panel is shown as being installed in MOD Control Panel (drawing TP-05) and in the SCADA RTU Cabinet (drawing TP-12). Please clarify where the HMI panel is required to be installed.

**The HMI panel is to be installed on the door of the MOD Control Panel. The RTU Cabinet shall have no door mounted components.**



9. In order to perform a correct sizing of battery charger, we would like to be clarified on the following: i. Which type of battery (flooded, valve regulated) is being used? The spec section 16900, paragraph 2.2.M. says valve regulated lead acid, but then it also refers to the cell electrolyte having a specific gravity between 1.210 and 1.222 which is typical for flooded (1.300 typical for VRLA). Please advise. ii. Spec section 16900 paragraph 2.2.M.1.a.3) says the battery capacity shall not be less than 200Ah. If it is more than 200Ah we would need to know a more accurate number on this requirement.

**Battery to be VRLA with calculations to support the 200Ahr minimum capacity. If greater capacity is required, it will be handled by a change order.**

10. Please see the e-mail below from RTU house manufacturer and advise if the bid due date could be extended.

**No extension will be issued at this time.**

11. I looking for information on the water main pipe requirements & support details.

**Multiple details for this are shown on sheet C-501. Also, connection of water pipe at top of post to match existing connection which shall be approved by NJ TRANSIT. A note has been added to Drawing C-501. Please see the revised C-501 Addendum 1 drawing with Revision B clouds showing the note for the water post dated 05-01-17.**

12. I also noticed the new wall that will be installed in lower than the existing wall? – Existing wall extends 3' above grade – New plans show it a top of sidewalk – and concern this wall act like a crash wall due to location and what is behind it?

**This is not meant to be a vehicular barrier. Additionally, the City of Hoboken is pursuing a project that would add a vehicular barrier on the other side of the adjacent, parallel bicycle path that would actually serve this purpose.**

13. Demo of RTU building – leave the slab & footing in place – I don't see a note to remove below grade?

**The requirement to “DEMO EXISTING RTU BUILDING” shown on plan sheets C-010 and C-100 is intended to include the slab/footing. It would not be feasible to install the foundation system as indicated on sheet S-100 and the conduits and duct banks shown on the structural and electrical without demolishing the existing slab/footing. Added “and foundation” to the demolition plan. Please see the revised C-010 Addendum 1 drawing with Revision B clouds showing the revised demolition note dated 05-01-17.**

14. Demo poles & footing – remove 12” below grade or completely?

**Per Specification Section 02220.3.4, the poles are to be removed completely.**

15. There is a bid item called Temp CLF 8’ high – 260 LF – I don’t see where you want it and any details for it. Is there any spec or details on what is required or does the contractor get to pick type. (Driven Post, Tension Wire T&B) etc.)

**Please see the attached revised Demolition Plan C-010 updated to show the location of the Temporary Chain Link Fence (Addendum 1, Revision B dated 05-01-17). Please see the attached Modified Chain Link Fence Specifications 02821 which includes measurement and payment of the temporary chain link fence.**

16. NJT wants to keep the walkway between the tracks and the LOD in place during construction. How wide of a path is required for this walkway because the 2’ over dig on SH footing and the temp SOE will encroach the LOD and this path.

**Enough of the existing walkway must remain open to allow for passage of a Cushman type golf cart vehicle.**

17. The specifications (02112) calls for a SMP with a stockpile operations. This section indicates that the CM will provide the stock pile location. Please provide the location of our stock pile for testing and hauling requirements.

**Temporary stockpile location will likely be south of adjacent Records Building, but space is limited, and location is not finalized. If longer term stockpiling is required, it will be on Hoboken Yard site, exact location TBD.**

18. Are there any geotechnical reports sent out with this RFP? I see a note in section 02466 – 1.4 C – Indicating STV provided a report using information from Contract 94CA035. Please provide geo information for review.

**The geotechnical report was already included as an attachment. With respect to Section 1.4C of the specifications for the N40 and N41 caisson installation work, the 2001 STV report referenced has no bearing on the RTU project and Poles N40 and N41, and is not available.**

19. During the excavation for the new RTU slab – excavation will be approx. 7' deep, we have to over excavate by 2' (Foundation Note 5) and the tracks are only approx. 15' away. – Please provide your track influence line detail so I can confirm if SOE is needed in this area. If temp SOE is needed will cost be added to the excavation item?

**Zone of influence is 45 degree splay from tracks. As such, 7-foot deep excavation that is 15 feet away from tracks should be outside the of that area, with no temporary structural measures required.**

20. Drawing C-010 shows the existing wall to be removed from the station - all the way past the Electric Control Building, however C-100 only shows us installing a new wall by the Electrical Control Building to ½ way to the station (actually shows North/East Cords). Please confirm wall limits.

**The wall removal limits and new wall limits shown on the Drawings C-010 and C-100 are correct. The entire curb wall is not being replaced so as to accommodate a proposed future project to install a new accessible pedestrian access path between Observer Highway and the Track 1 platform. Please see the revised C-010 and C-100 drawings with Revision B clouds.**

21. There are several overhead wires that appear to be in the way for drilling and for the installation of the new switch house and wall panels. Please confirm what these existing utilities are & who gets to move them. I don't believe the contractors will be allowed to touch these items. Based on existing wire height and new platform location, please confirm there is not a conflict between the two items.

**The overhead wires in question are NJ Transit communication cables. For cables that are in conflict with the proposed work, refer to Note 6 on Drawing E-011; cables that are not in conflict shall remain. The Contractor shall coordinate with NJ TRANSIT for these relocated cables.**

22. Please confirm what these existing utilities are & who gets to move them. I don't believe the contractors will be allowed to touch these items.

**The overhead wires in question are NJ Transit communication cables. For cables that are in conflict with the proposed work, refer to Note 6 on Drawing E-011; cables that are not in conflict shall remain. The Contractor shall coordinate with NJ TRANSIT for these relocated cables.**

23. Based on existing wire height and new platform location, please confirm there is not a conflict between the two items.

**The overhead wires in question are NJ TRANSIT communication cables. For cables that are in conflict with the proposed work, refer to Note 6 on Drawing E-011; cables that are not in conflict shall remain. The Contractor shall coordinate with NJ TRANSIT for these relocated cables.**

24. Subject questions "The Downguy Anchor:
- The plans show the depth as 36.6' min drilled anchor, but the bid data sheet reads 10 LF – please advise.
  - The length of the steel post is unknown – please advise.
  - Please advise on the location of Pole OCS D7+42 to help understand where the guywire will go & if it will impact the Metal wall panel system.

**The total depth of the drilled shaft including a 5' concrete plug is 36.5 feet. The depth of the drilled shaft in the Bid Item has been revised from LF to a Lump Sum bid item (LS item, Quantity 1), to match Specification Section 02383.**

**Refer to Note 2 on Drawing C-502 for determining the column height to maintain the existing back guy angle. Contractor shall field verify existing conditions.**

**Pole OCS D7+42 – It is anticipated that the guy wire will not impact the metal wall panels; final determination shall be made in the field.**

25. Spec section 16900 indicated that the RTU will have a fire suppression system and refers to spec section 16720. There is no spec 16720 in the bid so the RTU supplier will not provide.

**There is no fire suppression system in the RTU and Specification Section 16720 is not applicable.**

26. Please provide additional information regarding the curb wall. The typical curb wall detail does not provide enough information to properly bid the item. This wall is a substantial structure that is approx. 7' tall and supporting 4' of roadway fill. The drawings currently imply this is basically a simple replacement of a section of curb with no real details, including rebar, etc. Is temporary sheeting needed to support the excavation due to the proximity to the existing roadway, or rail side? There is also an existing utility pole on the street side that is to remain with main overhead utilities on it. It appears that pole could be in direct conflict with the excavation and new wall footing. Provide additional details of how that wall can be built with regards to the existing utility conflicts. Is there enough clearance to build the wall footing adjacent to the existing signal house and the existing utility pole that is to remain? Has NJ Transit coordinated with the city

regarding construction access to demo & build this wall, as it appears most of this work will have to be done from the road side. Will temporary construction barrier be needed along the construction limits? Also, please provide as-builts of the existing wall for review.

**Please see the revised C-501 drawing with Revision B clouds showing the curb wall rebar dated 05-01-17.**

**Contractor shall provide sheeting as required to support the roadway.**

**The existing utility poles and other structures to remain are not anticipated to interfere with the wall footing.**

**The City of Hoboken does not have an issue with accessing the site from the Observer Highway side during construction, with the provision that the area will be cleared as required by the City in the event of an emergency.**

**Contractor shall provide temporary fence as shown on the revised Demolition Plan C-010 updated to show the location of the Temporary Chain Link Fence (Addendum 1, Revision B dated 05-01-17). Please see the attached Modified Chain Link Fence Specifications 02821 which includes measurement and payment of the temporary chain link fence.**

**As-builts of the existing wall are not available.**

## SECTION 02060

### AGGREGATE

#### PART 1 GENERAL

##### 1.1 SECTION INCLUDES

- A. Aggregate materials.

##### 1.2 RELATED SECTIONS

- A. General Provisions for Construction
- B. Section 02055 - Soils.
- C. Section 02311 - Rough Grading.
- D. Section 02319 - Backfill.
- E. Section 02324 - Trenching.
- F. Section 02721 - Aggregate Base Course.

##### 1.3 REFERENCES

- A. New Jersey Department of Transportation Standard Specifications for Road and Bridge Construction- 2007 or latest edition.
- B. AASHTO - M147 - Materials for Aggregate and Soil-Aggregate.
- C. AASHTO T180 - Moisture-Density Relations of Soils Using a 10-lb Rammer and an 18-in. Drop.
- D. ANSI/ASTM C136 - Method for Sieve Analysis of Fine and Coarse Aggregates.
- E. ANSI/ASTM D698 - Test Methods for Moisture-Density Relations of Soils and Soil-Aggregate Mixtures, Using 5.5 lb Rammer and 12 inch Drop.
- F. ANSI/ASTM D1557 - Test Methods for Moisture-Density Relations of Soils and Soil-Aggregate Mixtures Using 10 lb Rammer and 18 inch Drop.
- G. ASTM D2167 - Test Method for Density and Unit Weight of Soil in Place by the Rubber Balloon Method.
- H. ASTM D2487 - Classification of Soils for Engineering Purposes.

- I. ASTM D2922 - Test Methods for Density of Soil and Soil-Aggregate in Place by Nuclear Methods (Shallow Depth).
- J. ASTM D3017 - Test Methods for Moisture Content of Soil and Soil-Aggregate Mixtures.
- K. ASTM D4318 - Test Method for Liquid Limit, Plastic Limit, and Plasticity Index of Soils.

#### 1.4 SUBMITTALS

- A. Submit in accordance with the, "General Provisions".
- B. Samples: Submit, in air-tight containers, 10 lb. sample of each type of fill to testing laboratory.
- C. Materials Source: Submit name of imported materials suppliers. Provide materials from same source throughout the work. Change of source requires Construction Manager's approval.

### PART 2 PRODUCTS

#### 2.1 AGGREGATE MATERIALS

- A. Aggregates for Bituminous Concrete: shall be in compliance with NJDOT Section 901.05
- B. Aggregates for Bituminous-Stabilized base course shall be in compliance with NJDOT Section 901.05
- C. Aggregates for Bituminous Surface treatment shall be in compliance with NJDOT Section 901.05
- D. Aggregates for Portland Cement Concrete, Mortar and Grout shall be in compliance with NJDOT Section 901.06
- E. Aggregate for Curb Wall shall be in compliance with NJDOT Section 901.03 Table 901.03-1 #57.

- F. Aggregate for "Gravel Surface Section" shall be in compliance with NJDOT Section 901.03 Table 901.03-1 #57.

#### 2.2 SOURCE QUALITY CONTROL

- A. Field inspection and testing will be performed in accordance with the General Provisions.
- B. Tests and analysis of aggregate material will be performed in accordance with

NJDOT.

- C. If tests indicate materials do not meet specified requirements, change material and retest.

## PART 3 EXECUTION

### 3.1 STOCKPILING

- A. Materials shall be removed off site as required or stockpiled on site at locations approved by the Construction Manager.
- B. Stockpile in sufficient quantities to meet project schedule and requirements.
- C. Separate differing materials with dividers or stockpile apart to prevent mixing.
- D. Direct surface water away from stockpile site so as to prevent erosion or deterioration of materials.
- E. All stock piles approved by the Construction Manager shall have sediment filter installed around the base to prevent erosion. Refer to standard details in the contract plan set for installation of the sediment filter.

### 3.2 STOCKPILE CLEANUP

- A. Remove stockpile, leave area in a clean and neat condition. Grade site surface to prevent freestanding surface water.
- B. If a borrow area is indicated, leave area in a clean and neat condition. Grade site surface to prevent freestanding surface water.

## PART 4 MEASUREMENT AND PAYMENT

### 4.1 PAYMENT

- A. Costs for aggregate materials shall be included with the base bids for associated Sections requiring the use of the materials covered under this Section. The respective bid shall include costs for all excavation, hauling, stockpiling, placement, removal, disposal and cleanup.
- B. The bid shall be full compensation for furnishing all labor, tools, equipment, materials and other incidentals necessary to complete the specified task.

### 4.2 MEASUREMENT

- A. Work covered by this Section shall not be measured.

END OF SECTION



## SECTION 02721

### AGGREGATE BASE COURSE

#### PART 1 GENERAL

##### 1.1 SECTION INCLUDES

- A. Aggregate base course.

##### 1.2 RELATED SECTIONS

- A. General Provisions for Construction.
- B. Section 02055 - Soils
- C. Section 02060 – Aggregate.
- D. Section 02741 – Flexible Pavements.

##### 1.3 REFERENCES

- A. New Jersey Department of Transportation - Standard Specification for Road and Bridge Construction - 2007 or latest edition.
- B. AASHTO T180 - Moisture-Density Relations of Soils using a 10-lb Rammer and an 18-in. Drop.
- C. ANSI/ASTM D698 - Test Methods for Moisture-Density Relations of Soils and Soil-Aggregate Mixtures, Using 5.5 lb Rammer and 12 inch Drop.
- D. ANSI/ASTM D1557 - Test Methods for Moisture-Density Relations of Soils and Soil-Aggregate Mixtures Using 10 lb Rammer and 18 inch Drop.
- E. ASTM D2167 - Test Method for Density and Unit Weight of Soil in Place by the Rubber Balloon Method.
- F. ASTM D2922 - Test Methods for Density of Soil and Soil-Aggregate in Place by Nuclear Methods (Shallow Depth).
- G. ASTM D3017 - Test Methods for Moisture Content of Soil and Soil-Aggregate Mixtures.

#### PART 2 PRODUCTS

##### 2.1 FILL MATERIALS

- A. All aggregates shall conform to Sections 02055 and 02060.
- B. Dense Graded Aggregates shall be used for all paved areas and all concrete pads,

walks, and other site items.

C. Coarse Aggregate #57 shall be used for "Gravel Surface Section" 4" Thick.

## PART 3 EXECUTION

### 3.1 EXAMINATION

A. Verify substrate has been inspected; gradients and elevations are correct and dry.

### 3.2 AGGREGATE PLACEMENT

A. Spread aggregate over prepared substrate to a total compacted thickness of six (6) inches or as noted on contract drawings.

B. Place aggregate in maximum twelve (12) inch layers, loose depth, and compact.

C. Level and contour surfaces to elevations and gradients as indicated on contract drawings.

D. Add small quantities of fine aggregate to course aggregate as appropriate to assist compaction.

E. Add water to assist compaction. If excess water is apparent, remove aggregate and aerate to reduce moisture content.

F. Use mechanical tamping equipment in areas inaccessible to compaction equipment.

### 3.3 TOLERANCES

A. Flatness: Maximum variation of 3/4 inch measured with 10 foot straight edge at random locations not to exceed 500 feet. All depressions shall be corrected by removing the entire layer and replacing it with new material. High spots may be removed by methods that provide an acceptable surface.

B. Scheduled Compacted Thickness: Within plus 3/4 inch or minus 1/2 inch, determined from random test holes dug at intervals not to exceed 500 feet. Test holes are to be refilled with base course material and re-compacted.

C. Variation from True Elevation: Within 1/2 inch.

### 3.4 FIELD QUALITY CONTROL

A. Field inspection and testing will be performed in accordance with the General Provisions.

B. Compaction testing will be performed in accordance with standards conforming to

NJDOT Standard Specifications 2007.

- C. If tests indicate Work does not meet specified requirements, remove Work, replace and retest.
- D. Frequency of Tests: Shall Conform to NJDOT Standard Specifications 2007.

### 3.5 SCHEDULES

- A. Under Asphalt Pavement:
  - 1. Compact placed Dense Graded Aggregate materials to achieve compaction to 95 percent maximum density.
- B. Under Concrete Pavement:
  - 1. Compact placed Dense Graded Aggregate materials to achieve compaction to 95 percent maximum density.

## PART 4 MEASUREMENT AND PAYMENT

### 4.1 PAYMENT

- A. Work covered by this Section shall be compensated for in the corresponding "Flexible Pavements" and "Rigid pavements" Square yard bids, except that "Gravel Surface Section" shall be compensated for in the Square Yard "DENSE-GRADED AGGREGATE BASE COURSE, 4" THICK" bid. The price will include all costs for excavation, placement, storage, hauling, disposal and cleanup for all work as outlined in the contract documents.
- B. The bid shall not reflect any item which explicitly defines its bid price as including the cost of the Aggregate Base Course.
- C. The bid shall be full compensation for furnishing all labor, tools, equipment and other incidentals necessary to complete the specified task.

### 4.2 MEASUREMENT

- A. "Gravel Surface Section" shall be measured by the Square Yard. Remaining work covered by this Section shall not be measured.

END OF SECTION

SECTION 02821

CHAIN LINK FENCE AND GATES

PART 1 GENERAL

1.01 SECTION INCLUDES

- A. This Section includes materials applicable for commercial/industrial, security, and temporary chain link fence and gates.
  - 1. Galvanized steel coated chain link fabric
  - 2. Galvanized steel framework and fittings
  - 3. Gates: swing
  - 4. Barbed wire
  - 5. Installation

1.02 RELATED WORK

- A. 03300 Cast-In-Place Concrete

1.03 REFERENCES

- A. ASTM C920 Standard Specification for Elastomeric Joint Sealants
- B. ASTM A121 Specification for Metallic-Coated Carbon Steel Barbed Wire
- C. ASTM A392 Specification for Zinc-Coated Steel Chain-Link Fence Fabric
- D. ASTM A824 Specification for Metallic-Coated Steel Marcellled Tension Wire for Use With Chain Link.
- E. ASTM F552 Standard Terminology Relating to Chain Link Fencing
- F. ASTM F567 Standard Practice for Installation of Chain Link Fence
- G. ASTM F626 Specification for Fence Fittings
- H. ASTM F900 Specification for Industrial and Commercial Swing Gates
- I. ASTM F1083 Specification for Pipe, Steel, Hot-Dipped Zinc-Coated (Galvanized) Welded, for Fence Structures
- J. CLFMI SFR 2445 Security Fence Recommendations
- K. CLFMI WLG2445 Chain Link Fence Wind Load Guide for the Selection of Line Post and Line Post Spacing

1.04 SUBMITTALS

- A. Shop drawings: Site plan showing layout of fence location with dimensions, location of gates and opening size, cleared area, elevation of fence and gates, details of attachments and footings.
- B. Certifications: Manufacturers material certifications in compliance with current

ASTM specifications.

- C. Domestic certifications: Material certifications, Made in U.S.A., Buy American Act or Buy America when required.
- B. Specification Changes: May not be made after the date of bid.

#### 1.05 QUALITY ASSURANCE

- A. Manufacturer: Company operating in the United States having U.S. manufacturing facility/facilities specializing in manufacturing chain link fence products with at least 5 years experience.
- B. Fence contractor: Company with demonstrated successful experience installing similar projects and products in accordance with ASTM F567 and have at least 5 years experience.
- C. Tolerances: Current published edition of ASTM specifications tolerances apply. ASTM specification tolerances supersede any conflicting tolerance.

#### 1.06 DELIVERY, STORAGE AND HANDLING

- A. Delivery: Deliver products to site per contract requirements.
- B. Storage: Store and protect products off the ground when required.

### PART 2 PRODUCTS

#### 2.01 MANUFACTURERS

- A. Framework, posts, rails, pipe for gates:
  - 1. Ameristar Fence Products
  - 2. Merchant Metals (281) 372-3800
  - 3. Swan Fence Inc. (310-669-8000)
  - 4. Approved Equals
- B. Fabric, fittings, gates and accessories:
  - 1. Ameristar Fence Products
  - 2. Merchant Metals (281) 372-3800
  - 3. Swan Fence Inc. (310-669-8000)
  - 4. Approved Equals

#### 2.02 CHAIN LINK FABRIC

- A. Steel Chain Link Fabric: 5/8" in. mesh, 11 gauge 8'-0" high per ASTM A392, top selvage knuckle, bottom selvage knuckle.
  - 1. Zinc-Coated Steel Fabric: ASTM A392 hot dipped galvanized before or after weaving.
    - a. Class 1 - 1.2 oz/ft<sup>2</sup> (366 g/m<sup>2</sup>)

#### 2.03 STEEL FENCE FRAMEWORK

- A. Round steel pipe and rail: ASTM F1043 Group IA Heavy Industrial Fence Framework,

schedule 40 galvanized pipe per ASTM F1083. Exterior zinc coating Type A, interior zinc coating Type A. High Strength 83000 Grade.

1. Line Post: 2.875 in. OD, 5.80 lb/ft
2. End, Corner, Pull post: 3.5 in. OD, 7.58 lb/ft
3. Top, brace, bottom and intermediate rails, 1.660 in. OD, 2.27 lb/ft

#### 2.05 TENSION WIRE

- A. Metallic Coated Steel Marcellled Tension Wire: 7 gauge (0.177 in.) (4.50 mm) marcellled wire complying with ASTM A824. Match coating type to chain link fabric.

#### 2.06 BARBED WIRE

- A. Metallic Coated Steel Barbed Wire: Comply with ASTM A121, Design Number 12-4-5-14R, double 12-½ gauge (0.099 in.) twisted strand wire, with 4 point 14 gauge (0.080 in.) round barbs spaced 5 inches on center. Match coating type to that of the chain link fabric.

#### 2.07 FITTINGS

- A. Tension and Brace Bands: Galvanized pressed steel complying with ASTM F626, minimum steel thickness of 12 gauge (0.105 in.) (2.67 mm), minimum width of 3/4 in. (19 mm) and minimum zinc coating of 1.20 oz/ft<sup>2</sup> (366 g/m<sup>2</sup>). Bands supplied with 5/16 in. (7.94 mm) or 3/8 in. (9.53 mm) galvanized steel carriage bolts.
- B. Terminal Post Caps, Line Post Loop Tops, Rail and Brace Ends, Boulevard Clamps, Rail Sleeves: In compliance to ASTM F626, pressed steel galvanized after fabrication having a minimum zinc coating of 1.20 oz/ft<sup>2</sup> (366 g/m<sup>2</sup>).
- C. Truss Rod Assembly: In compliance with ASTM F626, 3/8 in. (9.53 mm) diameter steel truss rod with a pressed steel tightener, minimum zinc coating of 1.2 oz/ft<sup>2</sup> (366 g/m<sup>2</sup>), assembly capable of withstanding a tension of 2,000 lbs. (970 kg).
- D. Tension Bars: In compliance with ASTM F626. Galvanized steel one-piece length 2 in. (50 mm) less than the fabric height. Minimum zinc coating 1.2 oz. /ft<sup>2</sup> (366 g/m<sup>2</sup>).
  1. Bars for small mesh 3/8 in., 1/2 in., and 5/8 in., shall be attached (sandwiched) to the terminal post using a galvanized steel strap having a minimum cross section of 2 in. (51 mm) by 3/16 in. (4.8 mm) with holes spaced 15 in. (381 mm) on center to accommodate 5/16 in. (7.9 mm) carriage bolts which are to be thru bolted thru the strap the mesh and thru the terminal post.
- E. Barbed Wire Arms: In compliance with ASTM F626, pressed steel galvanized after fabrication, minimum zinc coating of 1.20 oz. /ft<sup>2</sup> (366 g/m<sup>2</sup>), capable of supporting a vertical 250 lb (113 kg) load. Type I – three strand 45 degree (0.785 rad) arm.

#### 2.08 TIE WIRE and HOG RINGS

- A. Tie wire and hogs rings per ASTM F626. Match coating type to that of the chain link fabric.

#### 2.09 SWING GATES

- A. Swing Gates: single opening (see drawings for size). Galvanized steel welded fabrication in compliance with ASTM F900. Gate frame members 1.900 in. OD, [ASTM F1043 Group

IA F1083 schedule 40 pipe. Frame members spaced no greater than 8 ft. apart vertically and horizontally. Welded joints protected by applying zinc-rich paint in accordance with ASTM Practice A780. Positive locking gate latch fabricated of 5/16 in. (7.9 mm) thick by 1 3/4" pressed steel galvanized after fabrication. Galvanized malleable iron or heavy gauge pressed steel post and frame hinges. Match gate fabric to that of the fence system. Gateposts 3.5 in, OD, 7.58 lb/ft. Security chain to be core hardened with 1/2 in. OD links. Padlock to be stainless steel security lock, with anti bumping mechanism, keyed as per New Jersey Transit standards, American Lock A6461 or approved equal.

### PART 3 EXECUTION

#### 3.01 CLEARING FENCE LINE

- A. Clearing: Surveying, clearing, grubbing, grading and removal of debris for the fence line or any required clear areas adjacent to the fence. Surveying, clearing, grubbing, grading and removal of debris for the fence line Or any required clear areas adjacent to the fence is not included in the earthwork contractor's contract and is the responsibility of the fence contractor in accordance with the provisions of 02230 Site Clearing.

#### 3.02 FRAMEWORK INSTALLATION

- A. Posts: Posts shall be set plumb in concrete footings in accordance with ASTM F567. Top of post concrete footing to be crowned to shed water away from post. If a concrete foundation is not required, the Contractor may drive posts to the required depth if ground conditions permit. When solid rock is encountered, install posts not required to be set in concrete by drilling the rock to the required depth and securing with mortar.
- B. Top rail: When specified, install 21 ft. lengths of rail continuous thru the line post or barb arm loop top. Splice rail using top rail sleeves minimum 6 in. long. The rail shall be secured to the terminal post by a brace band and rail end. Bottom rail or intermediate rail shall be field cut and secured to the line posts using boulevard bands or rail ends and brace bands.
- C. Terminal posts: End, corner, pull and gate posts shall be braced and trussed for fence 6 ft. and higher and for fences 5 ft. (1.5 m) in height not having a top rail. The horizontal brace rail and diagonal truss rod shall be installed in accordance with ASTM F567.
- D. Tension wire: Shall be installed 4 in. up from the bottom of the fabric. Fences without top rail shall have a tension wire installed 4 in. down from the top of the fabric. Tension wire to be stretched taut, independently and prior to the fabric, between the terminal posts and secured to the terminal post using a brace band. Secure the tension wire to the chain link fabric with a 9 gauge hog rings 18 in. on center and to each line post with a tie wire.

#### 3.03 CHAIN LINK FABRIC INSTALLATION

- A. Chain Link Fabric: Install fabric to outside of the framework. Attach fabric to the terminal post by threading the tension bar through the fabric; secure the tension bar to the terminal post with tension bands and 5/16 in. carriage bolts spaced no greater than 12 inches on center. Small mesh fabric less than 1 in. attach to terminal post by sandwiching the mesh between the post and a vertical 2 in. wide by 3/16 in. steel bar using carriage bolts, thru bolted thru the bar, mesh and post spaced 15 in. on center. Chain link fabric to be stretched taut free of sag. Fabric to be secured to the line post with tie wires spaced no greater than 12 inches on center and to rail spaced no greater than 18 inches on center. Secure fabric to the tension wire with hog rings spaced no greater than 18 inches apart. Pre-formed 9 gauge galvanized steel power-fastened tie wire shall be wrapped 360 degrees around the post or rail and fabric picket, twist the two wire ends together three full turns per ASTM F626. Excess wire shall be cut off

and bent over to prevent injury. The installed fabric shall have a ground clearance of no more than 2 inches.

#### 3.04 BARBED WIRE INSTALLATION

- A. Barbed Wire: Stretched taut between terminal posts and secured in the slots provided on the line post barb arms. Type 1 barb arm shall have an outward installation.

#### 3.05 GATE INSTALLATION

- A. Swing Gates: Installation of swing gates and gateposts in compliance with ASTM F567. Direction of swing shall be outward. Gates shall be plumb in the closed position having a bottom clearance of 3 in. grade permitting. Hinge and latch offset opening space from the gate frame to the post shall be no greater than 3 in. in the closed position. Double gate drop bar receivers shall be set in a concrete footing minimum 6 in. diameter 24 in. (609.6 mm) deep. Gate leaf holdbacks shall be installed for all double gates.

#### 3.06 NUTS AND BOLTS

- A. Bolts: Carriage bolts used for fittings shall be installed with the head on the secure side of the fence. All bolts shall be peened over to prevent removal of the nut.

#### 3.07 ELECTRICAL GROUNDING

- A. Grounding: Grounding of the fence and gates is not the responsibility of the fence contractor and not included in the fencing scope of work for this contract. A licensed electrical contractor shall install grounding.

#### 3.08 NUTS AND BOLTS

- A. Clean Up: The area of the fence line shall be left neat and free of any debris caused by the installation of the fence.

#### 3.09 TEMPORARY CHAIN LINK FENCE

- A. Before beginning construction activities, erect temporary chain link fence required to enclose construction areas. Provide a 10' wide access gate to allow for construction access; location to be approved by NJT. Construct temporary fence as described in this section above. Maintain temporary fence as directed during construction and properly dispose of after it is no longer needed for the project.

### PART 4 COMPENSATION

#### 4.01 MEASUREMENT

- A. Chain Link Fences and Gates, and Temporary Chain Link Fence and Gates will be measured by the linear foot along the bottom line of the fabric.



4.02 PAYMENT

- A. Payment for Chain Link Fences and Gates will be made at the linear foot price bid for the item "CHAIN LINK FENCES AND GATES". Payment for Temporary Chain Link Fences and Gates will be made at the linear foot price bid for the item "TEMPORARY CHAIN LINK FENCING, 8' HIGH". Price shall include all costs for labor, materials, tools, equipment and incidentals necessary to complete the work.
- B. Separate payment will not be made for concrete footing-mounted chain link fence. All costs therefor shall be included in the price per linear foot bid for the items "CHAIN LINK FENCES AND GATES" and "TEMPORARY CHAIN LINK FENCING, 8' HIGH".

END OF SECTION

CITY OF HOBOKEN

COUNTY OF HUDSON

NOTES:

1. CONTRACTOR SHALL PROTECT UTILITY LINES UTILITY POLES, ELECTRICAL CABINETS, PUMP STATION, SIGNAL HOUSE, AND RECORDS BUILDING.
2. SEE SPECIFICATIONS FOR DEMOLITION REQUIREMENTS.
3. AERIAL WATER MAIN TO BE RELOCATED AND EXISTING FENCE AND WALL TO BE REMOVED PRIOR TO START OF CONSTRUCTION OF RTU PLATFORM.

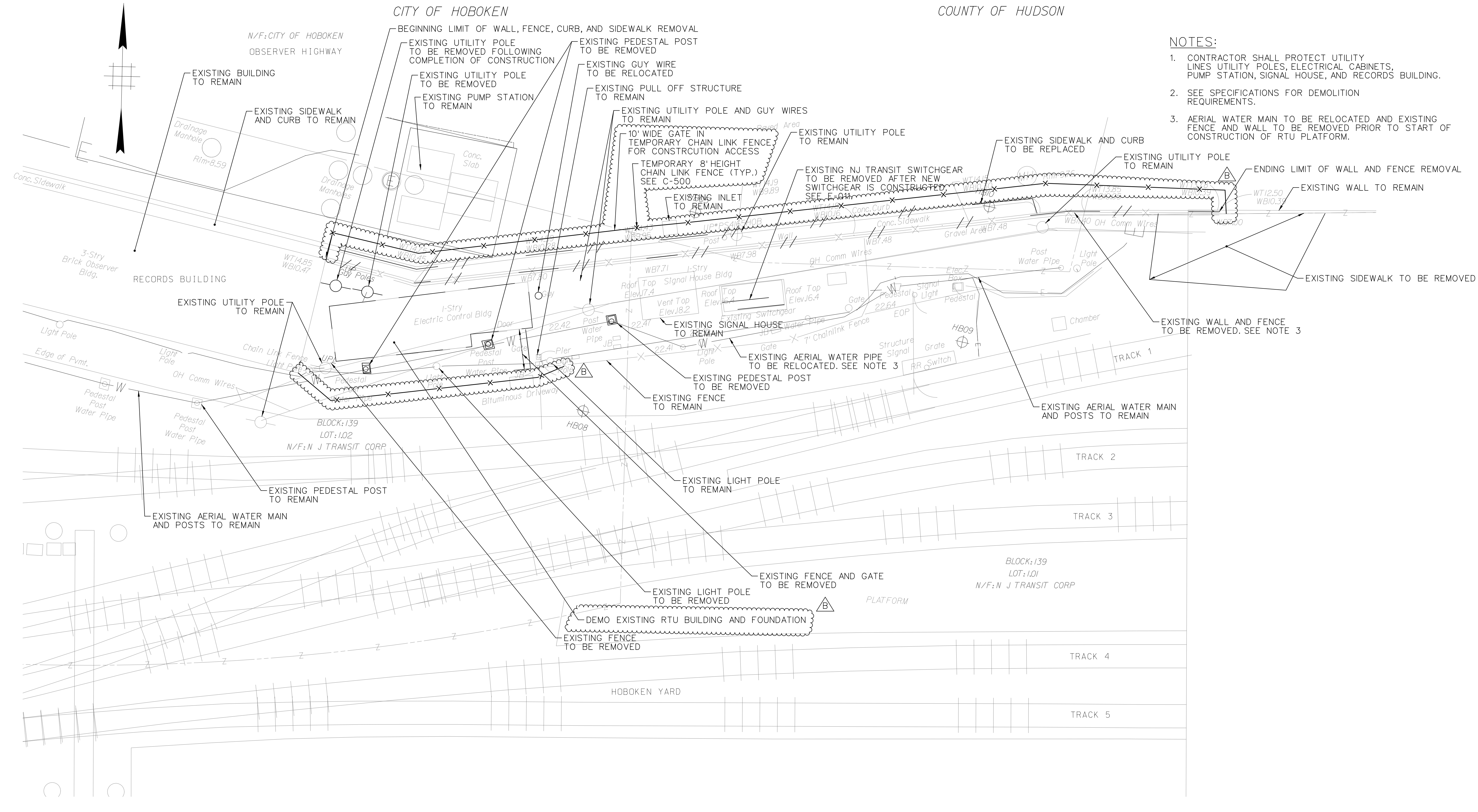

CIVIL - OBSERVER HIGHWAY DEMOLITION PLAN

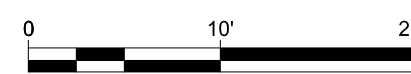

5/2/2017 3:38:59 PM / SZAPOTICZNY / SZAPOTICZNY / SZAPOTICZNY\00357412\HOB\_OH\_C-010.DGN

SUBMISSIONS			REVISIONS		
No.	Date	DESCRIPTION	No.	Date	DESCRIPTION
B	05-01-17	ADDENDUM I			
A	11-21-16	100% SUBMISSION			

Date	05-01-17	<b>GANNETT FLEMING, INC.</b> ONE CRAGWOOD ROAD, SUITE 205, SOUTH PLAINFIELD, NJ 07080 CERTIFICATE OF AUTHORIZATION NO. 24GA28032500  <b>JAMES M. DZIEDZIAK</b> DATE <small>NEW JERSEY PROFESSIONAL ENGINEER LICENSE NO. 24GE03746700</small>
Des.	SZ	
Dwn.	RB	
Chkd.	JL	
Apprvd.	JD	
Scale	1"=10'	



HOBOKEN TERMINAL/YARD  
OBSERVER HIGHWAY

CIVIL  
DEMOLITION PLAN

Contract No.  
16-042X  
Drawing  
C-010  
Sheet  
4 of 36

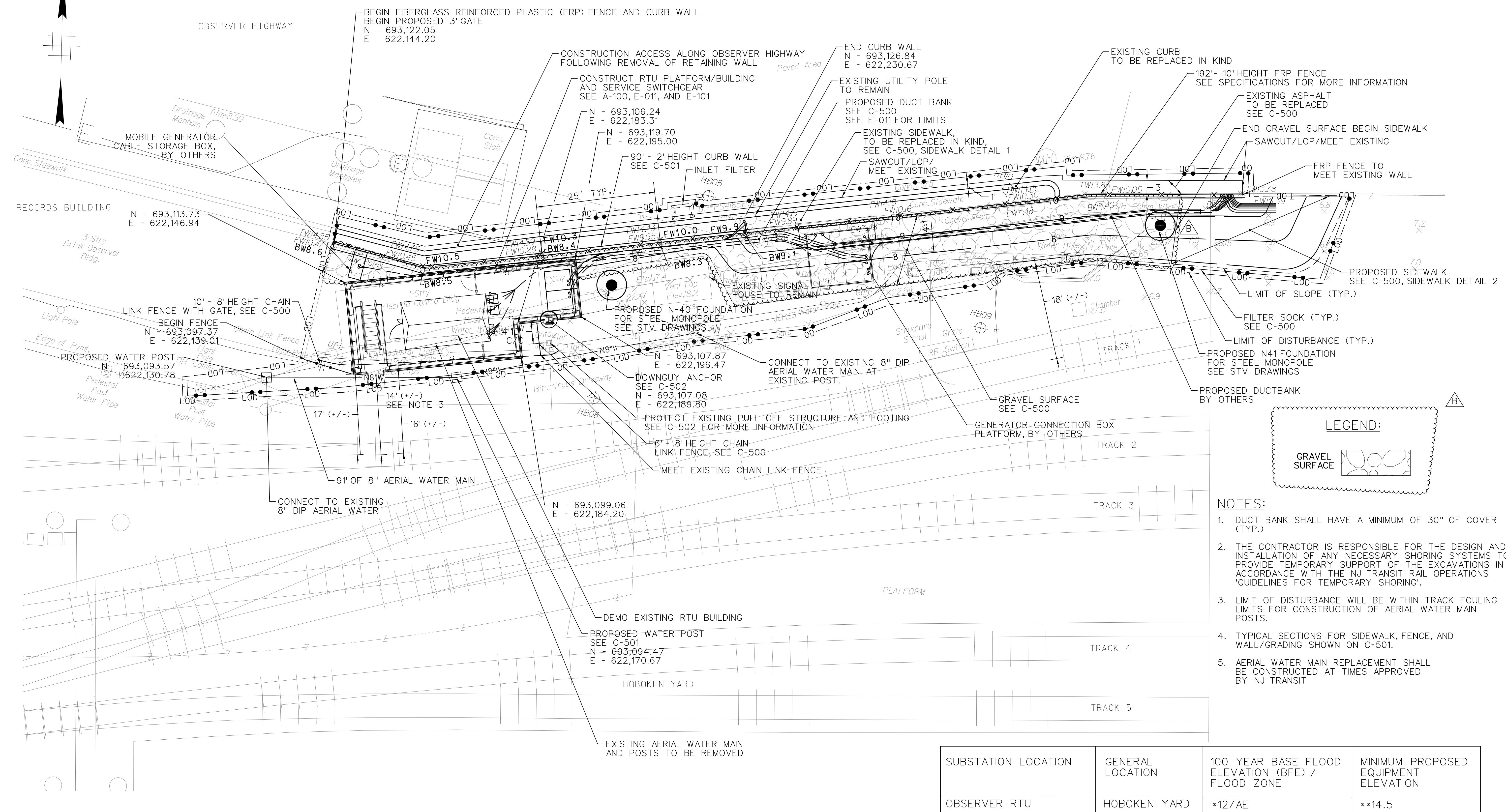

- NOTES:**
1. DUCT BANK SHALL HAVE A MINIMUM OF 30" OF COVER (TYP.)
  2. THE CONTRACTOR IS RESPONSIBLE FOR THE DESIGN AND INSTALLATION OF ANY NECESSARY SHORING SYSTEMS TO PROVIDE TEMPORARY SUPPORT OF THE EXCAVATIONS IN ACCORDANCE WITH THE NJ TRANSIT RAIL OPERATIONS 'GUIDELINES FOR TEMPORARY SHORING'.
  3. LIMIT OF DISTURBANCE WILL BE WITHIN TRACK FOULING LIMITS FOR CONSTRUCTION OF AERIAL WATER MAIN POSTS.
  4. TYPICAL SECTIONS FOR SIDEWALK, FENCE, AND WALL/GRADING SHOWN ON C-501.
  5. AERIAL WATER MAIN REPLACEMENT SHALL BE CONSTRUCTED AT TIMES APPROVED BY NJ TRANSIT.

SUBSTATION LOCATION	GENERAL LOCATION	100 YEAR BASE FLOOD ELEVATION (BFE) / FLOOD ZONE	MINIMUM PROPOSED EQUIPMENT ELEVATION
OBSERVER RTU	HOBOKEN YARD	*12/AE	**14.5

\* PRELIMINARY/REVISED PRELIMINARY FIRM RELEASE DATE: 01/30/2015  
 \*\* SEE ARCHITECTURAL PLANS FOR PROPOSED ELEVATIONS

**CIVIL - SITE PLAN**

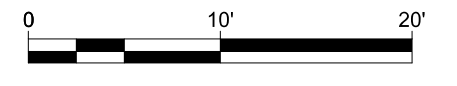

5/1/2017 3:27:59 PM SZAPOTICZNY C:\PWORKING\GFPW01\SZAPOTICZNY\0357412\HOB\_OH\_C\_100.DGN

SUBMISSIONS			REVISIONS		
No.	Date	DESCRIPTION	No.	Date	DESCRIPTION
B	05-01-17	ADDENDUM I			
A	11-21-16	100% SUBMISSION			

Date	05-01-17	<b>GANNETT FLEMING, INC.</b> ONE CRAGWOOD ROAD, SUITE 205, SOUTH PLAINFIELD, NJ 07080 CERTIFICATE OF AUTHORIZATION NO. 24GA28032500
Des.	SZ	
Dwn.	RB	
Chkd.	JL	
Apprvd.	JD	
Scale	1"=10'	<b>JAMES M. DZIEDZIAK</b> DATE NEW JERSEY PROFESSIONAL ENGINEER LICENSE NO. 24GE03746700



HOBOKEN TERMINAL/YARD OBSERVER HIGHWAY		Contract No. 16-042X
CIVIL SITE PLAN		Drawing C-100
		Sheet 5 of 36

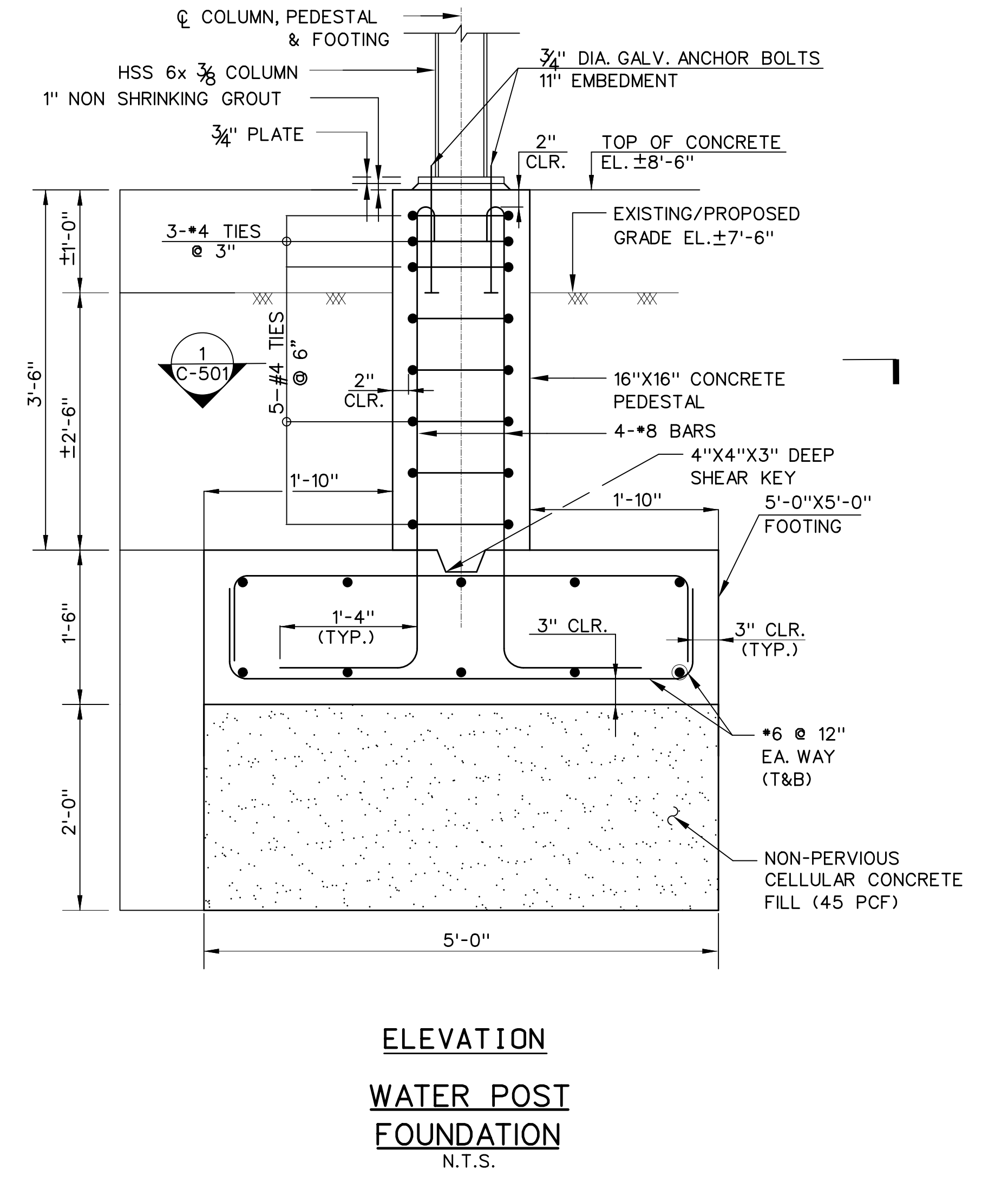
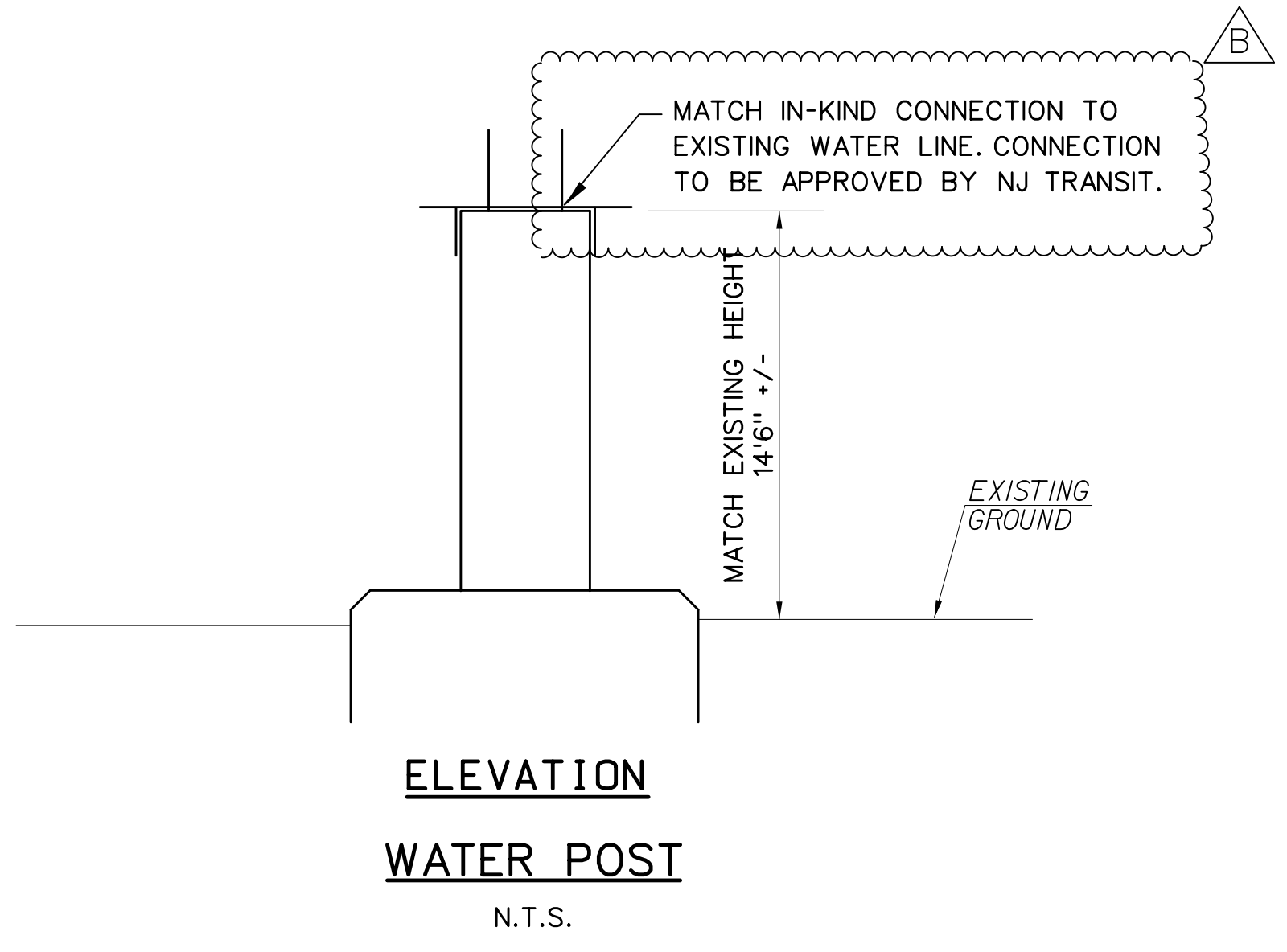
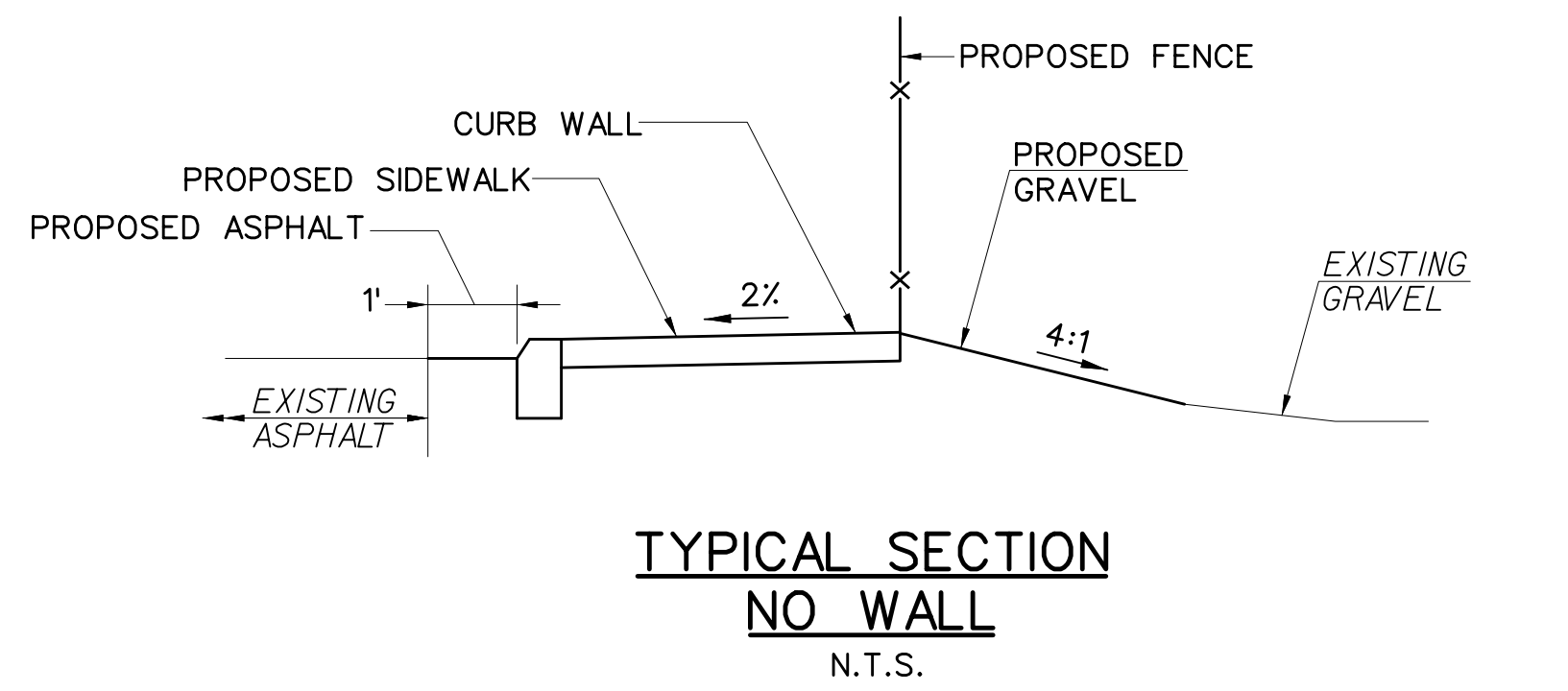
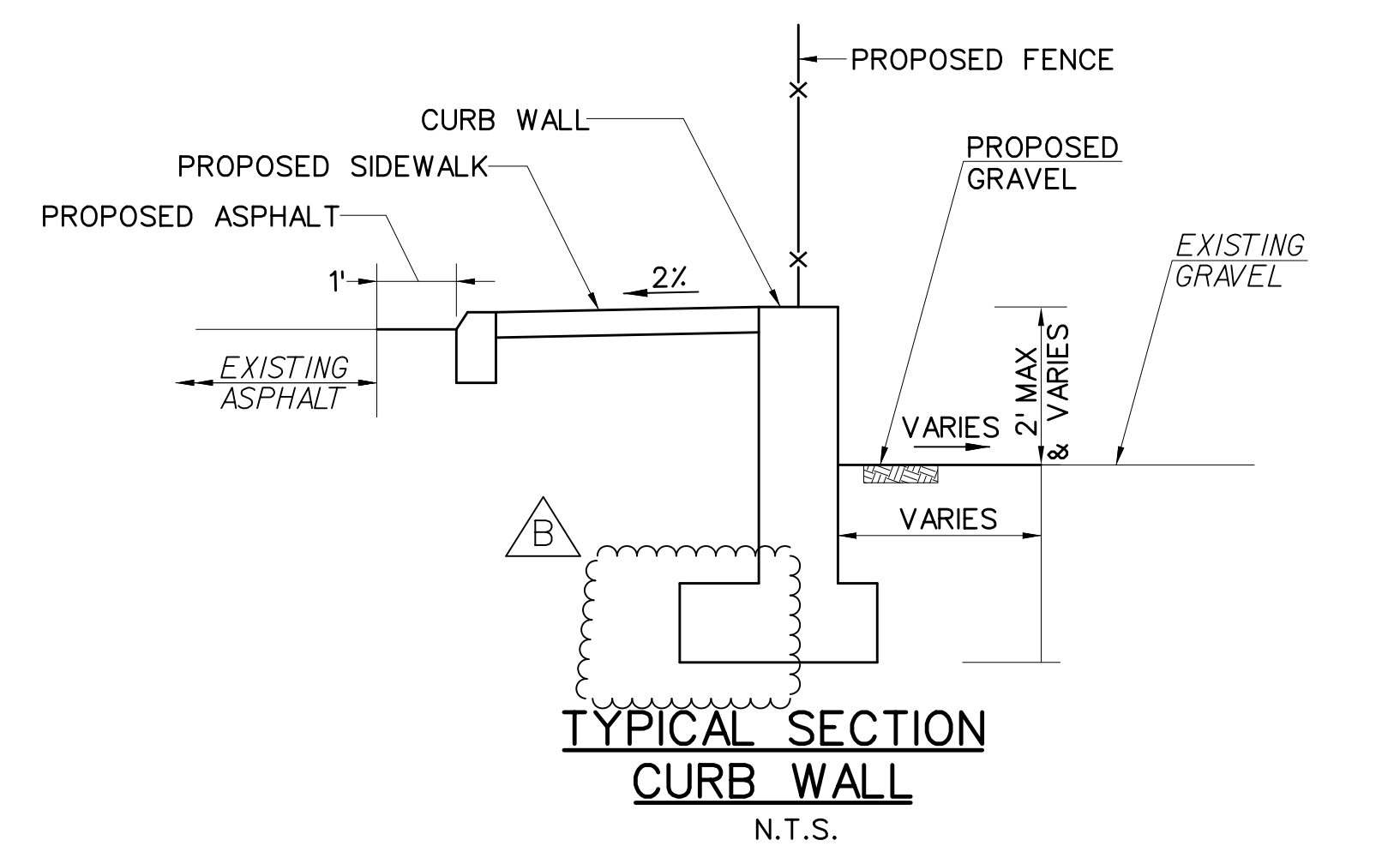
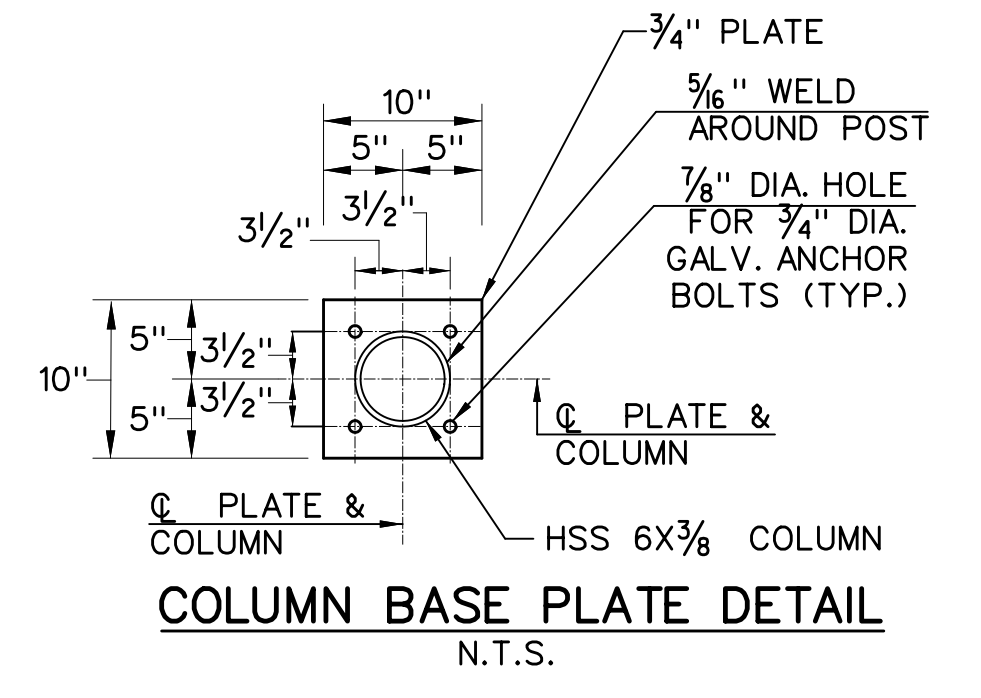
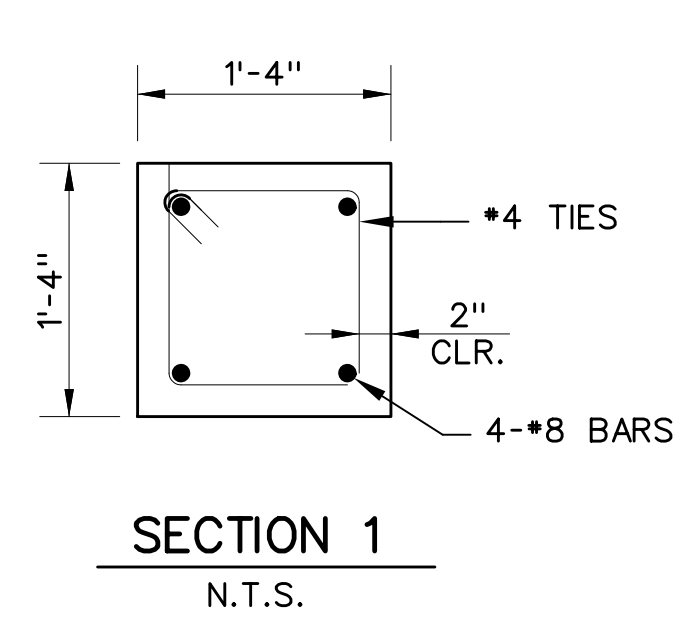
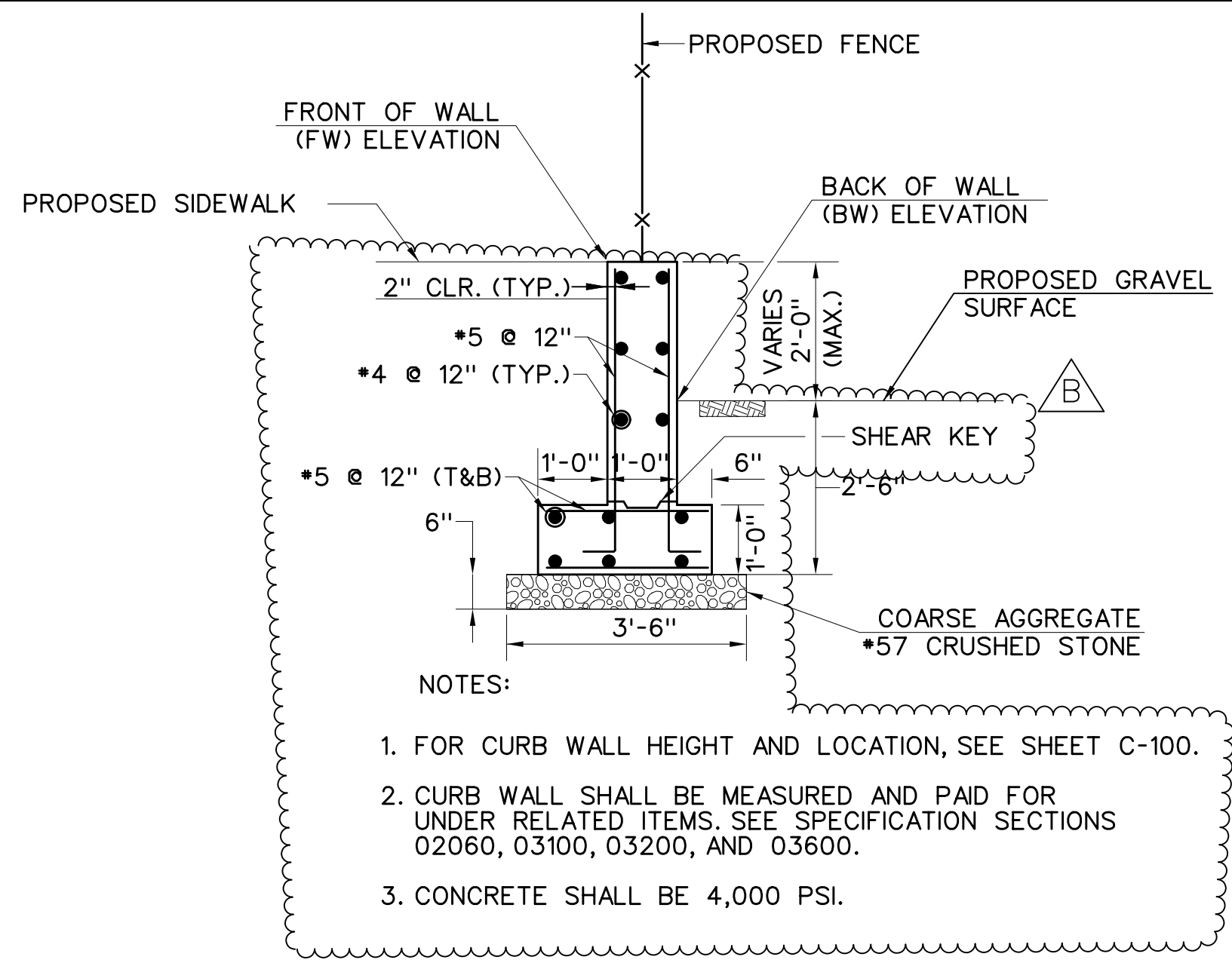

5/1/2017 2:20:19 PM SZAPOTICZNY C:\PWORKING\GFPW01\SZAPOTICZNY\00357412\HOB\_OH\_C-501.DGN

No.	Date	DESCRIPTION	No.	Date	DESCRIPTION
B	05-01-17	ADDENDUM I			
A	11-21-16	100% SUBMISSION			

Date	05-01-17	<b>GANNETT FLEMING, INC.</b> ONE CRAGWOOD ROAD, SUITE 205, SOUTH PLAINFIELD, NJ 07080 CERTIFICATE OF AUTHORIZATION NO. 24GA28032500  <b>JAMES M. DZIEDZIAK</b> DATE <small>NEW JERSEY PROFESSIONAL ENGINEER LICENSE NO. 24GE03746700</small>
Des.	SZ	
Dwn.	RB	
Chkd.	JL	
Apprvd.	JD	
Scale	NONE	



HOBOKEN TERMINAL/YARD  
OBSERVER HIGHWAY  
  
CIVIL DETAILS II

Contract No.  
16-042X  
Drawing  
C-501  
Sheet  
7 of 36

Chris Christie, Governor  
Kim Guadagno, Lieutenant Governor  
Richard T. Hammer, Commissioner  
Steven H. Santoro, Executive Director

**NJ TRANSIT**  
One Penn Plaza East  
Newark, NJ 07105-2246  
973-491-7000

April 4, 2017

**Re: NJ TRANSIT Invitation for Bid No. 16-042X  
Observer Highway Switching House - Hoboken Terminal  
Addendum No. 2**

To Whom it May Concern:

The following constitutes Addendum No. 2 and must be acknowledged with each bid. Prospective bidders are advised of the following clarifications, additions and/or revisions to the above referenced Invitation for Bid:

1. Enclosed for Bidders information is a Pre-Bid Data Sheet summarizing information discussed at the Pre-Bid Conference is included as Attachment A.
2. The Attendance Sheet from the Pre-Bid Conference held April 3, 2017 is included as Attachment B.

This concludes Addendum No. 2. An authorized representative of your organization shall acknowledge receipt of this Addendum in the Exhibit provided with its bid. Failure to acknowledge receipt of all Addenda may cause the rejection of the Bid as non-responsive.

Sincerely,



Maggie Sotolongo  
Senior Contract Specialist  
Procurement Department

## **Attachment A**

**Invitation for Bid No. 16-042X  
Observer Highway Switching House - Hoboken Terminal**

**INVITATION FOR BID (IFB) NO. 16-042X  
OBSERVER HIGHWAY SWITCHING HOUSE - HOBOKEN TERMINAL  
PRE-BID CONFERENCE AGENDA**

**Monday, April 3, 2017, 2:00 pm**

**Agenda**

- |                                 |   |
|---------------------------------|---|
| I. Introduction                 | Maggie Sotolongo, Senior Contract Specialist  |
| II. Proposal Process            | Maggie Sotolongo, Senior Contract Specialist  |
| III. DBE Goal and Requirements  | Maggie Sotolongo, Senior Contract Specialist for<br>Melisa Campusano, Business Development Specialist,<br>Contract Compliance |
| IV. Project Overview            | Kelly Giblin, Project Manager   |
| V. Questions and Answer Session |   |

**I. Introduction**

**Attendance Sheet**

<b>Project Dates:</b>	Pre-Bid Conference	April 3, 2017, 2:00 pm
	Site Visit	April 5, 2017, 11:00 am
	Questions Due:	April 10, 2017 (COB)
	Prequalification's Due:	April 10, 2017 (COB)
	Bid Opening:	May 9, 2017, 2:00 pm

**II. Proposal Requirements and Process**

**Obtaining Bid Documents:**

This Project is being bid by use of an electronic bidding process. Electronic bidding information is available on NJ TRANSIT's electronic bidding website: [www.bidx.com](http://www.bidx.com) Registration and a subscription fee are required to access the Bid Documents. The Bidder shall download the bidding software. The Bidder shall not alter or in any way change the software.

The Bidder shall address questions or problems with downloading or using electronic files, not requirements of the Contract, to:

NJ TRANSIT Bid Express Administrator  
E-Mail: [e-bidding@njtransit.com](mailto:e-bidding@njtransit.com)

Or

Bid Express Customer Support  
Tel: (352) 381-4888  
Fax: (352) 381-4444  
E-Mail: [customer.support@bidx.com](mailto:customer.support@bidx.com)

**Obtaining a Digital ID:**

Contractors need to apply for a Digital ID at least seven (7) business days prior to a letting if they want to submit a bid through Bid Express.

**Communications:**

Communications regarding this Invitation for Bid are to be conducted through NJ TRANSIT's Procurement Department. All other contacts are considered improper and are prohibited. Violation of this prohibition may cause for removal of a bidder from consideration for award of this contract.

Bidders are also advised that any discussions held regarding this project are considered informal and are not binding. The only means for modifying the Invitation for Bid is through a formal written Addendum. Therefore, any inquiries or requests for clarification must be submitted in writing. Inquiries and requests for clarification may be faxed to Maggie Sotolongo (973) 232-1892 or e-mailed [msotolongo@njtransit.com](mailto:msotolongo@njtransit.com). Any response NJ TRANSIT elects to make will be made by a written Addendum to the Bid and issued to all plan holders.

**Prequalification:**

Classification: "BR" (Building Construction – Railroad Environment) as a "GC" (General Contractor).

Suggested Minimum Rating: "J" (\$2,000,001 to \$3,000,000).

Bidders must be prequalified with NJ TRANSIT prior to submitting a bid. Bids received from contractors that are not prequalified or are prequalified with a rating insufficient to support its bid will be rejected. Prequalification questionnaires are available for download from the Bid Express website [www.bidx.com](http://www.bidx.com). Completed prequalification forms MUST be submitted by April 10, 2017 (COB).

Late submissions of prequalification questionnaires or submission of incomplete requests for prequalification may result in contractors not being prequalified to bid. Once processed, the prequalification classifications are valid for thirty-six (36) months.

Prequalification questionnaires are available through the Bid Express website.

Questions regarding prequalification status should be addressed to the Procurement Department.

**Inquiries and Requests for Clarification:**

All inquiries and requests for clarifications regarding the contract documents shall be submitted by e-mail to the Contract Specialist identified in the Special Provisions. Such requests shall state the Bid number and name of Project. Any response that NJ TRANSIT may choose to make will be by a written addendum to the Bid. NJ TRANSIT



will not be bound by any informal explanation, clarification, or interpretation, oral or written, by whomsoever made, that is not incorporated into an addendum to the Bid. All such Addenda will be posted on the electronic bidding website prior to the opening of Bids.

It is the obligation of the Bidder to check the website for addenda. Certain Addenda will contain Amendments. The Bidder shall ensure that the Schedule of Bid Items to be bid contains all applicable Amendments. NJ TRANSIT has the right to reject bids that do not contain all applicable Amendments to the Schedule of Bids Items to be bid.

All inquiries and requests for clarifications can be e-mailed to [msotolongo@njtransit.com](mailto:msotolongo@njtransit.com) or faxed to (973) 232-1892 and are due by April 10, 2017 (COB).

**Receipt of Bids:** Bidders who have been prequalified will be authorized to submit a bid.

The bids for this project are due on or before 2:00 pm, Tuesday, May 9, 2017. Bids are to be submitted electronically via Bid Express to NJ TRANSIT. Late bids will not be accepted.

Bids shall be accompanied by Bid Security in the form of a Bid Bond, Cashier's Check, Certified Check or irrevocable Letter of Credit. Cash is not considered an acceptable form of security.

The amount of the Bid Security shall equal to ten percent (10%) of the total bid amount. A Bid shall be rejected as non-responsive if it is not accompanied by satisfactory Bid Security.

**Please Note:** Your Bid Security can be obtained electronically via Bid Express or you may submit a hard copy from your bonding company. However, the hard copy of your bid security must be submitted prior to the Bid Opening.

When submitting a hard copy Bid Security, please send to NJ TRANSIT's Bid Desk, One Penn Plaza East, Sixth Floor, Newark, NJ 07105. Bid Security must be received by **2:00 pm, Tuesday, May 9, 2017.**

Please make sure to include the following information on the front of your envelope:

**16-042X  
OBSERVER HIGHWAY SWITCHING HOUSE - HOBOKEN  
TERMINAL  
Bid Bond**

**Award:** Award of Contract, if any, will be to that bidder who is deemed to be the lowest responsive and responsible bidder.

**Bid Validity:** One hundred eighty (180) days following the date of the bid opening.

**Time of Completion:** 450 calendar days from the effective date of the Notice-to-Proceed.

**Liquidated Damages:** \$3,000.00 per day each calendar day of delay in completing the work.

**Bonding**

**Requirements:** A Performance and Payment Bond is required for this project and shall be equal to 100% of the Contract price to secure fulfillment of the Contractor's obligations specified in the Contract.

**Insurance**

**Requirements:** The successful bidder is required to submit evidence of insurance coverage of the types in the amounts specified in the General and Special Provisions.

**III. DBE Goal and Requirements**

**DBE Goal:** A race conscious thirteen percent (13%) DBE goal has been set for this project. Bidders are to seek DBE participation under the State DBE Program.

**DBE Requirements:** For this Contract, the apparent low Bidder and the second low Bidder shall identify all DBE and non-DBE subcontractors, subconsultants, and suppliers proposed to participate in and those solicited for this Contract, and shall complete and submit the mandatory DBE Forms A, A1, A2, and B. The apparent low Bidder and the second low Bidder must also submit NJ Unified Certification Program (NJUCP) certificate or letter for all potential DBE subcontractors. Additionally, the apparent low Bidder and the second low Bidder shall submit any applicable supplemental forms (AA, AA1, AA2, BB, and D). All DBE forms and NJUCP certificates or letters shall be submitted with the Bid or within five (5) calendar days of the bid opening date.

However, Bidders are strongly encouraged to submit all mandatory documents with the Bid to prevent delay of the Contract award. Bidders are requested to review carefully and complete the forms entirely, with no blank fields.

Notwithstanding the date of submission of the mandatory DBE forms, all negotiations between a Bidder and any potential DBE subcontractor, subconsultant, or supplier shall be completed prior to the bid opening date.

**Failure to submit any and all mandatory DBE documentation within five (5) calendar days of the bid opening date shall result in a rejection of a Bid as non-responsible.**

Questions regarding DBE certification shall be submitted directly to NJ TRANSIT's Office of Business Development to the attention of:

Melisa Campusano  
Business Development Specialist, Contract Compliance  
(973) 491-8614  
mcampusano@njtransit.com

**IV. Project Overview**

**V. Question and Answer Session**

## **Attachment B**

**Invitation for Bid No. 16-042X  
Observer Highway Switching House - Hoboken Terminal**

NJ TRANST IFB NO. 16-042X  
OBSERVER HIGHWAY SWITCHING HOUSE - HOBOKEN TERMINAL

PRE-BID CONFERENCE ATTENDANCE SHEET

April 3, 2017, 2:00 pm

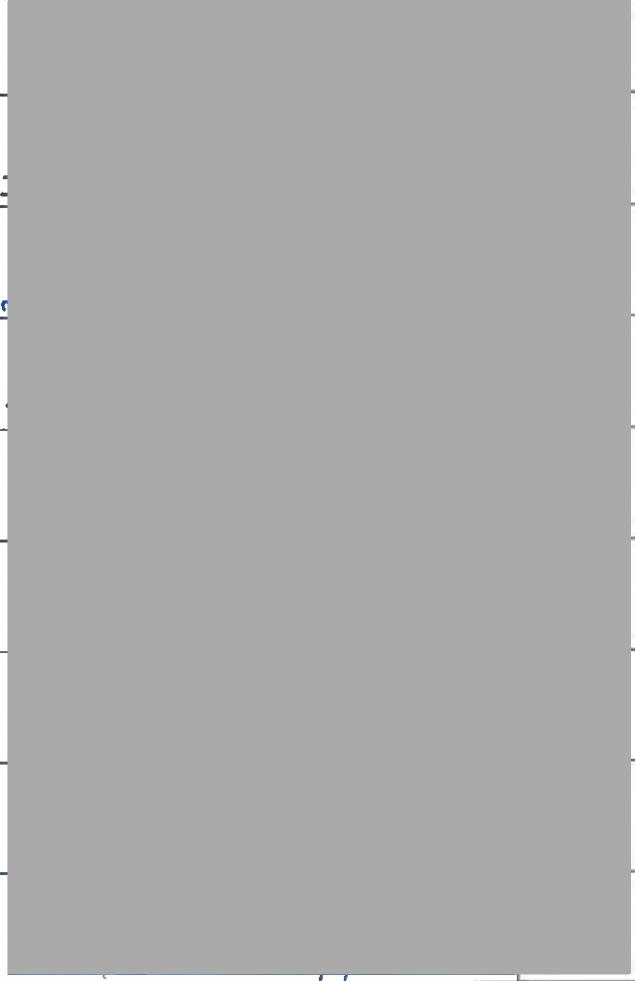
Printed Name of Attendee	Company Name	Email	SBE/DBE
Adam Schmit	RCC		
IAN BAKER	IEW CONSTRUCTION GROUP		
Michael Ondic	George Harms Construction		
Peter Gentle	HNTB Corp		
Douglas Flannery	NJT CM		
Kelly A. Giblin	NJTRANSIT - PM		
Victoria Vicari	NJ TRANSIT		
Jonathan D Smith	Beach Electric		
Umut Isler	Hall Building Grp.		



**Chris Christie**, Governor  
**Kim Guadagno**, Lieutenant Governor  
**Richard T. Hammer**, Commissioner  
**Steven H. Santoro**, Executive Director

**NJ TRANSIT**  
One Penn Plaza East  
Newark, NJ 07105-2246  
973-491-7000

March 20, 2017

To Whom it May Concern:

**Re: NJ TRANSIT Invitation for Bid No. 16-042X  
Observer Highway Switching House – Hoboken Terminal  
Addendum No. 1**

The following constitutes Addendum No.1 and must be acknowledged with each bid. Prospective bidders are advised of the following clarifications, additions and/or revisions to the above referenced Invitation for Bid. The prequalification requirement has been revised.

- Contractors must be prequalified for Building Construction – Rail (BR) in a classification of GC – General Contractor and for an amount of work that is equal to or greater than their bid amount. NJ TRANSIT suggests a minimum rating amount of “J”, \$2,000,001 to \$3,000,000.

This concludes Addendum No.1. An authorized representative of your organization shall acknowledge receipt of this Addendum in the Exhibit provided with its bid. Failure to acknowledge receipt of all Addenda may cause the rejection of the Bid as non-responsive.

Sincerely,



Maggie Sotolongo  
Senior Contract Specialist  
Procurement Department

**New Jersey Transit Corporation  
Instructions To Bidders For Construction**

**Table of Contents**

<b>A.</b>	<b>ABBREVIATIONS AND DEFINITIONS .....</b>	<b>1</b>
A.1	ABBREVIATIONS .....	1
A.2	DEFINITIONS.....	1
<b>B.</b>	<b>COMMUNICATIONS.....</b>	<b>1</b>
B.1	OBTAINING BID DOCUMENTS .....	1
B.2	INQUIRIES AND REQUESTS FOR CLARIFICATION .....	1
B.3	ACKNOWLEDGMENT OF RECEIPT OF ADDENDA.....	2
B.4	IMPROPER COMMUNICATIONS .....	2
B.5	PRE-BID CONFERENCE .....	2
<b>C.</b>	<b>REGISTRATIONS, PREQUALIFICATION AND DBE CERTIFICATION.....</b>	<b>2</b>
C.1	CORPORATE REGISTRATION .....	2
C.2	PREQUALIFICATION OF BIDDERS .....	3
C.3.	DISADVANTAGED BUSINESS ENTERPRISES("DBE") GOAL ASSIGNMENT .....	4
C.4	DEPARTMENT OF LABOR REGISTRATION .....	4
C.5	OWNERSHIP DISCLOSURE.....	5
C.6	DISCLOSURE OF POLITICAL CONTRIBUTIONS (N.J.S.A. 19:44A-20.27).....	6
C.7	BUSINESS REGISTRATION NOTICE .....	6
<b>D.</b>	<b>ETHICAL REQUIREMENTS FOR BIDDERS.....</b>	<b>7</b>
D.1	CODE OF ETHICS FOR BIDDERS .....	7
D.2	CERTIFICATION REGARDING DEBARMENT, SUSPENSION, INELIGIBILITY AND VOLUNTARY EXCLUSION – LOWER TIER COVERED TRANSACTION.....	7
D.3	STATE DEBARMENT AND SUSPENSION CERTIFICATION .....	9
D.4	LIMITATIONS ON LOBBYING .....	9
D.5	DISCLOSURE OF INVESTMENT ACTIVITIES IN IRAN .....	10



**New Jersey Transit Corporation  
Instructions To Bidders For Construction**

**Table of Contents**

<b>E.</b>	<b><i>BID PREPARATION AND SUBMISSION PROCEDURES</i></b> .....	<b>10</b>
E.1	EXAMINATION OF CONTRACT DOCUMENTS .....	10
E.2	BID FORM QUANTITIES .....	10
E.3	PREPARATION OF THE BID .....	11
E.4	DBE FORMS AND CERTIFICATION .....	11
E.5	BID GUARANTEE .....	12
E.6	BID VALIDITY .....	13
E.7	WITHDRAWAL OF BIDS .....	13
E.8	SUBMISSION OF MULTIPLE BIDS .....	14
E.9	SUBMISSION OF BIDS .....	14
<b>F.</b>	<b><i>BID OPENING</i></b> .....	<b>14</b>
F.1	PUBLIC OPENING OF BIDS .....	14
F.2	UNOPENED BIDS .....	14
F.3	CONDITIONALLY ACCEPTED .....	15
<b>G.</b>	<b><i>IRREGULAR BIDS</i></b> .....	<b>15</b>
G.1	IRREGULARITIES AND NON-CONFORMANCES .....	15
G.2	RIGHT TO REJECT OR WAIVE .....	15
<b>H.</b>	<b><i>AWARD AND EXECUTION OF CONTRACT</i></b> .....	<b>16</b>
H.1	CALCULATION OF BIDS .....	16
H.2	SINGLE BIDS .....	16
H.3	DETERMINATION OF LOW BID .....	16
H.4	AWARD PROCESS .....	16
H.5	CANCELLATION OF AWARD .....	16
H.6	CONTRACT BONDS .....	17

**New Jersey Transit Corporation  
Instructions To Bidders For Construction**

**Table of Contents**

H.7	EXECUTION OF CONTRACT .....	18
H.8	FAILURE TO EXECUTE CONTRACT .....	18
H.9	RELIEF OF BIDDERS .....	18
H.10	RELEASE OF BID GUARANTEES .....	18
<b>I.</b>	<b><i>PROTEST PROCEDURE</i></b> .....	<b>19</b>
I.1	PURPOSE .....	19
I.2	DEFINITIONS.....	19
I.3	PROCEDURE .....	19

**A. ABBREVIATIONS AND DEFINITIONS**

A.1 ABBREVIATIONS

See Article 1.1.1 of the General Provisions for Construction.

A.2 DEFINITIONS

See Article 1.1.2 of the General Provisions for Construction.

**B. COMMUNICATIONS**

B.1 OBTAINING BID DOCUMENTS

This Project is being bid by use of an electronic bidding process. Electronic bidding information is available on NJ TRANSIT's electronic bidding website: [www.bidx.com](http://www.bidx.com). Registration and a subscription fee are required to access the Bid Documents. The Bidder shall download the bidding software. The Bidder shall not alter or in any way change the software.

The Bidder shall download all Bid documents from NJ TRANSIT's electronic bidding website. NJ TRANSIT assumes no responsibility for errors or omissions in the downloaded documents except as specifically provided for in the Contract Documents. The Bidder shall address questions or problems with downloading or using the electronic files, not the requirements of the Contract, to:

NJ TRANSIT Bid Express Administrator

E-Mail: [e-bidding@njtransit.com](mailto:e-bidding@njtransit.com)

or

Bid Express Customer Support

Tel: (352) 381-4888

Fax: (352) 381-4444

E-Mail: [customer.support@bidx.com](mailto:customer.support@bidx.com)

B.2 INQUIRIES AND REQUESTS FOR CLARIFICATION

All inquiries and requests for clarifications regarding the Contract Documents shall be submitted by e-mail to the Contract Specialist identified in the Special Provisions. Such requests shall state the Invitation for Bid (IFB) number and name of Project. Any response that NJ TRANSIT may choose to make will be by a written Addendum to the IFB. NJ TRANSIT will not be bound by any informal explanation, clarification, or interpretation, oral or written, by whosoever made, that is not incorporated into an Addendum to the IFB. All such Addenda will be posted on the electronic bidding website

prior to the opening of Bids. It is the obligation of the Bidder to check the website for Addenda. Certain Addenda will contain amendments to the IFB. The Bidder shall ensure that the Schedule of Items to be bid contains all applicable amendments. NJ TRANSIT has the right to reject Bids that do not contain an acknowledgement of all applicable Addenda to the Schedule of Items to be bid. No response may be made by NJ TRANSIT to inquiries received less than ten (10) calendar days prior to the scheduled Bid opening.

**B.3 ACKNOWLEDGMENT OF RECEIPT OF ADDENDA**

Bidders are required to acknowledge receipt of all Addenda on the Bid Form in the space provided. Failure to acknowledge receipt of all Addenda may be grounds for the rejection of a Bid as non-responsive.

**B.4 IMPROPER COMMUNICATIONS**

In accordance with N.J.S.A. 52:34-10.1, Bidders are advised that communications with NJ TRANSIT that in any way relate to an IFB shall only be conducted with the Contract Specialist, the authorized representative of the Contracting Officer in NJ TRANSIT's Procurement Department. All other contacts, with the exception of contacting NJ TRANSIT's Office of Business Development for matters related to Disadvantage Business Enterprise (DBE) requirements, are strictly prohibited and are considered improper.

Bidders are advised that violation of this prohibition, as required by N.J.S.A. 52:34-10.1, may result in the rejection of a Bid or the removal of the Bidder from consideration for award of this Contract.

**B.5 PRE-BID CONFERENCE**

A pre-bid conference may be held with prospective Bidders to review the IFB, Contract Documents and generally discuss the Project. The time and place will be specified in the Advertisement. Bidders are strongly encouraged to attend.

**C. REGISTRATIONS, PREQUALIFICATION AND DBE CERTIFICATION**

**C.1 CORPORATE REGISTRATION**

In accordance with N.J.S.A. 14A:13-3, a foreign corporation (i.e., a corporation for profit organized under the laws of a jurisdiction other than New Jersey) that contracts to do business with NJ TRANSIT must have a certificate of authority to do business in the State of New Jersey. To obtain a certificate of authority, a foreign corporation should contact the New Jersey Business Registration and Commercial Recording Services Line

at (609) 292-9292, or go to the State of New Jersey's Business Gateway Registry Services (NJBGS) website at [www.state.nj.us/njbgs](http://www.state.nj.us/njbgs). The relevant documents, contained in the New Jersey Complete Business Registration Package (NJ-REG), instructions and customer service assistance are available from the above locations. No contract will be entered into by NJ TRANSIT with a Bidder unless the successful Bidder has obtained a certificate of authority to do business in New Jersey. In addition, all foreign companies must have a registered agent in the State of New Jersey upon whom process may be served and such information must be provided to NJ TRANSIT.

## C.2 PREQUALIFICATION OF BIDDERS

In accordance with N.J.A.C. 16:72-2.4, prospective Contractors, prior to bidding on capital improvement projects, must be prequalified as to the character and amount of work for which they are permitted to submit Bids. Such prequalification shall be assigned to Contractors based on all factors related to Contractor responsibility as set forth in N.J.A.C. 16:72-1.4, and any pertinent information relating to the qualification of Contractors, ("**Prequalification Classification and Rating**").

A Prequalification Classification and Rating shall be assigned to Contractors based on information submitted by them in response to the Prequalification Questionnaire available through NJ TRANSIT's electronic bidding website. A fully completed Prequalification Questionnaire must be received by NJ TRANSIT no later than the submittal date identified in the Special Provisions. Failure of a prospective Bidder to submit its fully completed Prequalification Questionnaire by that date may result in a denial of Prequalification for the IFB.

The required prequalification character for the type of work and suggested minimum rating amount will be identified in the Special Provisions for the IFB. Prospective Bidders are advised that a key consideration in the evaluation, classification and rating of the Contractor is past experience with work similar both in nature and in magnitude to the prequalification classification and rating requested by the Contractor. Failure, either in the Prequalification Questionnaire or in any subsequent information provided by the prospective Bidder, to demonstrate responsible experience with work of the nature and magnitude of the classification and rating requested may result in NJ TRANSIT assigning a different classification, lower rating, or both, or a rejection of the Prequalification request pending the submission of evidence of prior responsible experience. The Prequalification Classification and Rating shall be valid for thirty-six (36) months from the date of the Notice of Classification letter.

Please note that the prequalification classification will only be conducted for those Bidders who have subscribed to NJ TRANSIT's electronic bidding service, have downloaded the relevant Bid Documents from NJ TRANSIT's electronic bidding website [www.bidx.com](http://www.bidx.com), are intending to bid as a prime Contractor or as a member of a joint venture, and have submitted a completed Prequalification Questionnaire.

Firms seeking to submit Bids as Joint Ventures are advised that both firms must submit Prequalification Questionnaires independently, in addition to a Statement of Joint Venture form executed by both firms. A rating and classification shall be assigned to **each firm and a determination shall be made as to the Joint Venture's eligibility to submit a Bid in response to this IFB only.**

Two or more firms which maintain an ongoing Joint Venture relationship may request Prequalification as a single entity, provided they can demonstrate a past history of responsible performance as a single entity. In such event, the Prequalification Classification and Rating assigned to the entity shall be valid for thirty six (36) months.

#### C.3. DISADVANTAGED BUSINESS ENTERPRISES("DBE") GOAL ASSIGNMENT

Disadvantaged Business Enterprises, in accordance with the Department of Transportation (DOT) Regulations located at 49 C.F.R. Part 26, shall have the maximum opportunity to participate in the performance of this contract. The DBE subcontracting goals are identified in the Special Provisions for this Project.

#### C.4 DEPARTMENT OF LABOR REGISTRATION

Pursuant to The Public Works Contractor Registration Act, N.J.S.A. 34:11-56.48, et seq., Bidders are advised that Contractors shall not Bid on any contract for public work unless the Contractor is registered in accordance with N.J.S.A. 34:11-56.51. Public work is defined in N.J.S.A. 34:11-56.26(5). A Bidder can only list Subcontractor(s) in its Bid proposal if the Subcontractor(s) is registered in accordance with N.J.S.A. 34:11-56.48, et seq. Contractors or Subcontractors, including a Subcontractor not listed in the Bid, shall not engage in the performance of any public work subject to the Contract, unless the Contractor or Subcontractor is registered pursuant to the Act.

The Bidder shall possess a valid Public Works Contractor Registration Certificate at time of Bid submission. The Bidder is requested to provide its Public Works Registration Certificate number with its Bid submission. If requested, proof of valid registration shall

be submitted to NJ TRANSIT, in care of the Contract Specialist, within seven (7) calendar days of NJ TRANSIT's request.

The Bidder shall, after the Bid is made and prior to the awarding of the contract, submit to NJ TRANSIT the Public Works Contractor Registration Certificate for all Subcontractors listed in the Bid in accordance with N.J.S.A. 34:11-56.55. Applications for registration from either the Contractor or any Subcontractor shall not be accepted as a substitute for a certificate of registration.

Registration forms, copies of the Act and other relevant information may be obtained by contacting:

New Jersey Department of Labor and Workforce Development  
Division of Wage & Hour Compliance  
P.O. Box 389  
Trenton, New Jersey 08625-0389  
Telephone: (609) 292-9464  
Fax: (609) 633-8591

Companies not listed in the Bid that quote successfully as Subcontractors at any tier will be required to submit evidence of registration with the Department of Labor as part of the post-award Subcontractor approval process as detailed in General Provisions 1.9.2.

#### C.5 OWNERSHIP DISCLOSURE

Pursuant to N.J.S.A. 52:25-24.2, in the event the Bidder is a corporation, partnership or limited liability company, the Bidder must complete a current, Ownership Disclosure Form prior to the receipt of the Bid or accompanying the Bid. The Ownership Disclosure Form must set forth the names and addresses of all stockholders in a corporation who own ten percent (10%) or more of its stock, or of all the individual partners in the partnership who own a ten percent (10%) or greater interest, or of all the members in the limited liability company who own a 10 percent or greater interest. If one or more stockholders, partners, or members is itself a corporation, partnership, or limited liability company, the stockholders holding ten percent (10%) of more of that **corporation's stock**, or the individual partners owning ten percent (10%) or greater interest in that partnership, or the members owning ten percent (10%) of greater interest in the limited liability company, shall also be listed.

To comply with this requirement, a Bidder with any direct or indirect parent entity which is publicly traded may submit the name and address of each publicly traded entity and the name and address of each person that holds a ten percent (10%) or greater beneficial interest in the publicly traded entity as of the last annual filing with the Securities and Exchange Commission, and, if there is any person that holds a ten percent (10%) or greater beneficial interest, also shall submit links to the websites containing the last annual filings with the federal Securities and Exchange Commission or the foreign equivalent and the relevant page numbers of the filings that contain the information on each person that holds a ten percent (10%) or greater beneficial interest.

Failure to submit the form will result in the rejection of the Bid.

C.6 DISCLOSURE OF POLITICAL CONTRIBUTIONS (N.J.S.A. 19:44A-20.27)

The Bidder is advised of its responsibility to file an annual disclosure statement of any political contributions with the New Jersey Election Law Enforcement Commission (ELEC), pursuant to N.J.S.A. 19:44A-20.27 if the Bidder receives \$50,000 or more in the aggregate through agreements or contracts with a public entity in a calendar year. It is the **Bidder's** responsibility to determine if filing is necessary. Failure to so file can result in the imposition of financial penalties by ELEC. Additional information about this requirement is available from ELEC at 888-313-3532 or at [www.elec.state.nj.us](http://www.elec.state.nj.us).

C.7 BUSINESS REGISTRATION NOTICE

Pursuant to N.J.S.A. 52:32-44 (a), "**Business registration**" means a business registration certificate issued by the Division of Revenue in the Department of the Treasury or such other form of verification or proof of registration as may be approved by the Division that a Contractor or Subcontractor is registered with the Department of the Treasury.

In accordance with N.J.S.A. 52:32-44, the Bidder shall provide NJ TRANSIT with its Business Registration Certificate and that of any named Subcontractor(s) prior to the time a Contract is awarded or authorized. The Bidder is requested to provide its Business Registration Certificate number and Taxpayer Identification (FEIN) with Bid submission. The business registration form (Form NJ-REG) can be found online at <http://www.state.nj.us/treasury/revenue/busregcert.shtml>.

No Contract with a Subcontractor shall be entered into by any Contractor unless the Subcontractor first provides proof of valid business registration. In conjunction with the



Subcontractor approval process detailed in General Provision 1.9.2, the Contractor shall provide a copy of the Business Registration Certificate for each Subcontractor.

**D. ETHICAL REQUIREMENTS FOR BIDDERS**

**D.1 CODE OF ETHICS FOR BIDDERS**

Bidders are informed that it is NJ TRANSIT policy that Bidders who do or may do business with NJ TRANSIT must avoid all situations where proprietary or financial interest, or the opportunity for financial gain, could lead a NJ TRANSIT officer or employee to secure favored treatment for any organization or individual.

Bidders must also avoid circumstances and conduct which may not constitute actual wrongdoing, or conflict of interest, but might nevertheless appear questionable to the general public, thus compromising the integrity of NJ TRANSIT. All Bidders must comply with NJ TRANSIT's Code of Ethics as set forth in Article 10.4 of the General Provisions for Construction.

**D.2 CERTIFICATION REGARDING DEBARMENT, SUSPENSION, INELIGIBILITY AND VOLUNTARY EXCLUSION – LOWER TIER COVERED TRANSACTION.**

This section is governed by the requirements set forth in 2 C.F.R. Parts 180 and 1200. By signing and submitting a Bid the prospective lower tier participant, defined as the Contractor and its Subcontractors, is providing the certification set out below. The certification in this clause is a material representation of fact upon which reliance was placed when this transaction was entered into. If it is later determined that the prospective lower tier participant knowingly rendered an erroneous certification, in addition to other remedies available to the Federal Government, NJ TRANSIT may pursue available remedies, including suspension and/or debarment.

The prospective lower tier participant shall provide immediate written notice to NJ TRANSIT if at any time the prospective lower tier participant learns that its certification was erroneous when submitted or has become erroneous by reason of changed circumstances.

The prospective lower tier participant agrees by submitting a Bid that, should the proposed covered transaction be entered into, it shall not knowingly enter into any lower tier covered transaction with a person who is debarred, suspended, declared ineligible, or voluntarily excluded from participation in this covered transaction, unless authorized in writing by NJ TRANSIT.

The prospective lower tier participant further agrees by submitting a Bid that it will **include the clause titled "Certification Regarding Debarment, Suspension, Ineligibility and Voluntary Exclusion – Lower Tier Covered Transaction", without modification, in all** lower tier covered transactions (valued at \$25,000 or more) and in all solicitations for lower tier covered transactions.

A participant in a covered transaction may rely upon a certification of a prospective participant in a lower tier covered transaction that it is not debarred, suspended, ineligible, or voluntarily excluded from the covered transaction, unless it knows that the certification is erroneous. Each participant shall check the U.S. Government System for Award Management (SAM) database.

Nothing contained in the foregoing shall be construed to require establishment of a system of records in order to render in good faith the certification required by this clause. The knowledge and information of a participant is not required to exceed that which is normally possessed by a prudent person in the ordinary course of business dealings.

Except for transactions authorized under the fourth paragraph above, if a participant in a covered transaction knowingly enters into a lower tier covered transaction with a person who is suspended, debarred, ineligible, or voluntarily excluded from participation in this transaction, in addition to all remedies available to the Federal Government, NJ TRANSIT may pursue available remedies including suspension and/or debarment.

The prospective lower tier participant certifies by submission of this Bid that neither it nor its principals (as defined at 2 C.F.R. Part 180.995) is presently debarred, suspended, proposed for debarment, declared ineligible, or voluntarily excluded from participation in this transaction by any Federal department or agency. A participant may decide the method and frequency by which it determines the eligibility of its principals.

When the prospective lower tier participant is unable to certify to the statements in this certification, such prospective participant shall attach an explanation to this proposal.

The prospective lower tier participant shall also be currently registered and active with no exclusion on the U.S. Government System for Award Management (SAM) database.

D.3 STATE DEBARMENT AND SUSPENSION CERTIFICATION

The Bidder shall certify that neither it nor its principals are included on the State of New Jersey, Department of the Treasury, Consolidated Debarment Report or on the State of New Jersey, Department of Labor and Workforce Development, Division of Wage and Hour Compliance, Prevailing Wage Debarment List.

If the Bidder or its principals is included on such report, the Bidder may not be eligible for Award of Contract.

D.4 LIMITATIONS ON LOBBYING

(APPLICABLE FOR FEDERALLY FUNDED PROJECTS VALUED OVER \$100,000)

By signing and submitting a Bid, the prospective lower tier participant, defined as a Contractor or Subcontractor, is providing the signed certification set out below. This certification is a material representation of fact upon which reliance was placed when this transaction was made or entered into. Submission of this certification is a prerequisite for making or entering into this transaction imposed by 31 U.S.C. 1352. Any person who fails to file or amend a declaration required to be filed or amended under 31 U.S.C. 1352 shall be subject to a civil penalty of not less than \$10,000 and not more than \$100,000 for each such failure.

Bidder certifies, to the best of his or her knowledge and belief, that:

(1) No Federal appropriated funds have been paid or will be paid, by or on behalf of the undersigned, to any person for influencing or attempting to influence an officer or employee of any agency, a Member of Congress, an officer or employee of Congress, or an employee of a Member of Congress in connection with the awarding of any Federal Contract, the making of any Federal grant, the making of any Federal loan, the entering into of any cooperative agreement, and the extension, continuation, renewal, amendment, or modification of any Federal Contract, grant, loan, or cooperative agreement.

(2) If any funds other than Federal appropriated funds have been paid or will be paid to any person for influencing or attempting to influence an officer or employee of any agency, a Member of Congress, an officer or employee of Congress, or an employee of a Member of Congress in connection with this Federal Contract, grant, loan, or cooperative agreement, the undersigned shall complete and submit "Disclosure of Lobbying Activities," in accordance with its instructions.

(3) At the end of each calendar quarter in which there occurs any event that materially affects the accuracy of the information contained in any declaration previously filed in accordance with D.4.1 or D.4.2 above, Bidders shall file an updated certification or declaration, as appropriate, in accordance with 31 U.S.C. 1352.

(4) The Bidder shall require that the language of this certification be included in the award documents for all sub-awards at all tiers (including subcontracts, sub-grants, and contracts under grants, loans, and cooperative agreements) and that all sub-recipients shall certify and disclose accordingly.

D.5 DISCLOSURE OF INVESTMENT ACTIVITIES IN IRAN

Pursuant to N.J.S.A. 52:32-55 et seq., a Bidder that, at the time of Bid opening, is identified on a list created pursuant to such law by the New Jersey Department of the Treasury as a person or entity engaging in investment activities in Iran as described in such law, shall be ineligible to, and shall not, bid on or enter into a contract with NJ TRANSIT. As required by such law, the Bidder must complete the certification with its Bid to attest under penalty of perjury, that neither the person or entity nor any of its parents, subsidiaries or affiliates is identified on the **Department of Treasury's Chapter 25** list as a person or entity engaging in investment activities in Iran. Failure to complete the certification will render the Bid non-responsive and shall result in a rejection of the Bid.

**E. BID PREPARATION AND SUBMISSION PROCEDURES**

E.1 EXAMINATION OF CONTRACT DOCUMENTS

The Bidder shall examine carefully the Contract Documents, project site and conditions affecting the procurement. By submitting a Bid, the Bidder acknowledges that he has carefully examined the Contract Documents and project site, and has satisfied himself as to the conditions affecting the procurement. NJ TRANSIT assumes no responsibility for any conclusions or interpretations made by the Bidder on the basis of the information made available by NJ TRANSIT.

E.2 BID FORM QUANTITIES

E.2.1 The quantities stipulated are approximate and are given only as a basis for the comparison of Bids. NJ TRANSIT does not expressly, or by implication, represent that the actual amount of work will correspond to the estimated quantities stipulated in the Bid Form.

NJ TRANSIT reserves the right to increase or decrease the amount of any class or portion of the Work or omit portions of the Work.

E.2.2 The Bid Form may include Pay Items that have been designated as Allowances. Such items may or may not be shown on the Contract Drawings. NJ TRANSIT, in its sole discretion, may or may not incorporate Allowances into the Project.

### E.3 PREPARATION OF THE BID

E.3.1 The Bidder shall ensure that all Addenda, including Amendments to the Bid Form, are applied to the Bid and properly acknowledged. The Bidder shall insert the price for each Pay Item **in the appropriate box provided under the column designated "Unit Price"**. The only entries permitted in the Bid Form will be the lump sum prices or unit prices for items that shall be bid. The software will perform all extensions of the unit prices and calculate the total Bid amounts.

E.3.2 Prices shall be provided for all items called for on the Bid Form. All Bid prices must be quoted in numeric form. When the Bidder intends to bid zero dollars (\$0.00) for a Pay **Item, the Bidder shall insert a "0" in the appropriate box under the "Unit Price" column.** Where no figure is provided by the Bidder in the "Unit Price" column for one or more Contract Items, the Bid will be considered to be nonconforming and shall be rejected.

E.3.4 Alternate Bids for any item will not be considered unless specifically requested in the Bid.

E.3.4 The Bidder shall check the Bid before submission using the software. The Bidder shall **select "tools" and then select "check bid" and ensure there are no errors prior to submitting the electronic bid.** For **Bids submitted by Joint Ventures select "tools" from the software menu and mark the electronic bid as "Joint Bid."** The Bidder may print a completed Proposal Form for their records after completing the Bid.

### E.4 DBE FORMS AND CERTIFICATION

E.4.1 **All Bidders shall refer to NJ TRANSIT's DBE Requirements for Federally Funded Construction Contracts and Subcontracts for the requirements concerning the DBE obligations and mandatory submissions for this Contract.** In accordance with those requirements, the apparent low Bidder and the second low Bidder shall identify all DBE and Non-DBE subcontractors and suppliers proposed to participate in or those solicited for this contract, and must complete and submit the mandatory DBE Forms A, A1, A2,

B, and D, if applicable; the New Jersey Unified Certification Program (NJUCP) DBE certificate or letter; and any applicable supplemental forms AA, AA1, AA2 and BB to NJ TRANSIT, in the care of the Contract Specialist, within five (5) calendar days after the date for receipt of Bids. All negotiations between a Bidder and its DBE subcontractors must occur prior to the bid opening date.

The apparent low Bidder and second low Bidder are also required to submit DBE Certificates, as issued by the certifying agency, for each firm or Subcontractor listed on DBE Form A to NJ TRANSIT, in the care of the Contract Specialist, within five (5) calendar days after the date for receipt of Bids. Bidders are strongly encouraged to submit these forms with the Bid to prevent delay of award. Bidders are requested to review forms carefully and complete all forms in their entirety, with no blank fields. Failure to submit all mandatory forms within five (5) calendar days after the Bid opening date shall result in rejection of the Bid as non-responsible.

E.5 BID GUARANTEE

E.5.1 Bids shall be accompanied by Bid Security, as defined in N.J.A.C. 16:72-1.2, in the form of a Bid Bond, Cashier's Check, Certified Check or irrevocable Letter of Credit drawn to the order of NJ TRANSIT, to serve as a guarantee that the Bidder will, upon NJ TRANSIT's acceptance of its Bid, execute contractual documents as may be required. Cash is not considered an acceptable form of security.

E.5.2 Whenever the Bid Security accompanying the Bid is a Bid Bond in electronic form, the Bidder shall complete the electronic bond form. The Bidder shall ensure that the Bid Bond is properly completed and furnished by a corporation or corporations authorized to issue surety bonds in the State of New Jersey and listed in the current U.S. Treasury Department Circular 570 as of the date for the receipt of Bids and made payable to the New Jersey Transit Corporation.

Whenever the Bid Security accompanying the Bid is a Bid Bond in non-electronic form, the Bidder shall ensure that the Bid Bond is properly completed and furnished by a corporation or corporations authorized to issue surety bonds in the State of New Jersey and listed in the current U.S. Treasury Department Circular 570 as of the date for the receipt of Bids and made payable to the New Jersey Transit Corporation. The Bid Bond shall be delivered to NJ TRANSIT's Bid Desk located at One Penn Plaza East, 6<sup>th</sup> Floor, Newark, New Jersey, prior to the time and date set for the opening of Bids. Failure to

deliver such Bid Bond to NJ TRANSIT's Bid Desk prior to the time set for the opening of Bids shall result in rejection of the Bid as non-responsive.

- E.5.3 Pursuant to N.J.A.C. 16:72-2.2, whenever the Bid Security is a Letter of Credit, it shall be issued by a Federally insured financial institution, within the meaning of the Act creating the Federal Deposit Insurance Corporation (12 U.S.C. 1811). When the Bid Security accompanying the Bid is a Cashier's Check or a Certified Check, it shall also be drawn on an account with an "insured bank" within the meaning of the Act creating the Federal Deposit Insurance Corporation (12 U.S.C. 1811).

The Letter of Credit, Cashier's Check or Certified Check shall be delivered to NJ TRANSIT's Bid Desk located at One Penn Plaza East, 6<sup>th</sup> Floor, Newark, New Jersey prior to the time and date set for the opening of Bids. Failure to deliver such Cashier's Check, Certified Check or irrevocable Letter of Credit to NJ TRANSIT's Bid Desk prior to the time set for the opening of Bids shall result in rejection of the Bid as non-responsive.

Cashier's Checks, Certified Checks or irrevocable Letters of Credit based on accounts with or guaranteed by persons, corporations or institutions other than those identified in the preceding paragraph shall not be considered acceptable Bid Security and the Bid shall be declared non-responsive and will result in a rejection of the Bid.

- E.5.4 The amount of the Bid Security shall equal ten percent (10%) of the total amount Bid. A Bid shall be rejected as non-responsive if it is not accompanied by satisfactory Bid Security.

#### E.6 BID VALIDITY

NJ TRANSIT reserves the right to issue a Notice of Award to the successful Bidder, as determined by NJ TRANSIT, at any time for a period of one hundred-twenty (120) calendar days following the date of Bid opening. If necessary, requests for extensions of the date for issuance of the notice of award may be made by NJ TRANSIT by written request to Bidders. The Bid shall remain valid through the date NJ TRANSIT fully executes the contract.

#### E.7 WITHDRAWAL OF BIDS

Bids may be withdrawn at any time prior to the time specified for the opening of Bids by using the "Tools" feature of the software, selecting "View Submitted Bids" and then

**selecting "Withdraw Bid."** The withdrawal of a Bid does not prejudice the right of the Bidder to file a new Bid. Withdrawals received after the time specified for the opening of Bids are subject to N.J.A.C. 16:72-2.19.

E.8 SUBMISSION OF MULTIPLE BIDS

Submission of more than one Bid from an individual, firm, partnership, corporation or combination thereof under the same or different names shall be cause for disqualification of the Bids submitted by such entities. Reasonable grounds for believing that any individual, firm, partnership, corporation, or combination thereof, is interested as a principal in more than one Bid for the procurement contemplated may cause the rejection of all Bids submitted by such individual, firm, partnership, corporation, or combination thereof.

E.9 SUBMISSION OF BIDS

E.9.1 Once the Bidder has completed its Bid, the Bidder shall submit the electronically signed Bid via the Internet. The Bidder shall ensure delivery of its Bid with all required components and attachments.

E.9.2 The Bidder is solely responsible for any and all errors and for timely submission of the Bid, all components thereof, and all attachments thereto, through the electronic bidding system; NJ TRANSIT assumes no responsibility for any claim arising from the failure of any Bidder or of the electronic delivery system to cause any Bid, Bid component, or attachment to not be delivered to NJ TRANSIT on or before the time set for Bid opening.

**F. BID OPENING**

F.1 PUBLIC OPENING OF BIDS

Bids will be publicly opened and read aloud at the advertised time and place set for such Bid opening, unless NJ TRANSIT extends the time for opening of Bids. NJ TRANSIT reserves the right at its sole discretion to extend the time for opening of Bids at any time prior to the opening of the Bids. Their contents will be made public for the information of Bidders and other interested parties.

F.2 UNOPENED BIDS

NJ TRANSIT may reject a Bid and leave the Bid unopened, if the Bidder has not been prequalified in accordance with Paragraph C.2, above, or for other material violations of NJ TRANSIT's bidding requirements.



F.3 CONDITIONALLY ACCEPTED

All Bids opened by NJ TRANSIT shall be considered conditionally accepted pending NJ TRANSIT's detailed review and examination of the Bids.

**G. IRREGULAR BIDS**

G.1 IRREGULARITIES AND NON-CONFORMANCES

A. Bids will be considered irregular and shall be rejected for the following reasons:

1. If the Bid materially fails to conform to the requirements of the Invitation for Bids.
2. If the Bid is received from a firm which is not adequately prequalified or is otherwise determined to be not responsible.
3. If the Bid is not received by the specified date and time.
4. If the Bidder fails to furnish Bid Security in accordance with Paragraph E.5.
5. If the Bidder takes material exception to any of the Bid requirements.
6. If the Bid is not digitally signed by the authorized representative of the Bidder.
7. If the Bidder fails to deliver before receipt of the bid or with the bid, the Ownership Disclosure Form as required by N.J.S.A. 52:25-24.2.
8. If the Bidder fails to complete the Disclosure of Investment Activities in Iran certification.
9. If the Bidder or any named Subcontractor is not registered pursuant to the Public Works Contractor Registration Act, N.J.S.A. 34:11-56.48 et seq., at the time the bid is made.

B. Bids will be considered irregular and may be rejected for the following reasons:

1. If the Bidder fails to comply with all material EEO/DBE requirements.
2. If the Bidder fails to submit or complete any of the mandatory DBE forms.
3. Subject to Paragraph G.2, if the Bid is not properly completed.
4. If all Addenda are not properly acknowledged by the Bidder.
5. If the Bid contains prices that are materially unbalanced.
6. For other reasons, if NJ TRANSIT deems it advisable to do so in the public interest.

G.2 RIGHT TO REJECT OR WAIVE

NJ TRANSIT, in its sole discretion, reserves the right to reject any and all Bids and to waive informalities and minor irregularities in Bids received, notwithstanding other provisions of the Contract Documents.

## **H. AWARD AND EXECUTION OF CONTRACT**

### H.1 CALCULATION OF BIDS

H.1.1 After the Bids are opened and read, they will be compared on the basis of the correctly determined summation of the correctly determined products of all the quantities for Contract Items shown in the Bid multiplied by the unit prices Bid. The results of such comparisons will be made available to the public. Award will be made on the basis of the correct total Contract price.

H.1.2 In the event an error is encountered with the software and a discrepancy exists between the unit price Bid for any Contract Item and the extension shown for that item under the column of the Bid designated "Extension," the unit price shall govern.

### H.2 SINGLE BIDS

If only one Bid is received in response to the Invitation for Bids, a detailed cost proposal may be requested of the single Bidder. A cost/price analysis and evaluation and/or audit may be performed of the cost proposal in order to determine if the price is fair and reasonable.

### H.3 DETERMINATION OF LOW BID

The award of the firm-fixed-price Contract, if it is awarded, will be to that responsible Bidder whose Bid, conforming to the Invitation for Bids, is lowest in price.

### H.4 AWARD PROCESS

Contract Award is a process initiated by NJ TRANSIT when it issues the Notice of Award, includes the period when the Contractor executes and returns the Contract, and is completed when NJ TRANSIT executes the Contract.

### H.5 CANCELLATION OF AWARD

NJ TRANSIT reserves the right to cancel the Award of any Contract before execution of the Contract by NJ TRANSIT, even if it has been executed by the Contractor, if NJ TRANSIT deems such cancellation to be in its best interests. In no event will NJ TRANSIT have any liability for the cancellation of such award. The Contractor assumes sole risk and responsibility for any expenses incurred prior to execution of the Contract and shall not commence work until receipt of the written Notice to Proceed.

H.6 CONTRACT BONDS

Pursuant to N.J.S.A. 2A:44-143 through 147, as amended, and N.J.A.C. 16:72-2.3 the Bidder to whom the Contract is awarded shall furnish the following bonds in a form substantially similar to that provided by NJ TRANSIT.

- H.6.1 A Performance Bond equal to one-hundred percent (100%) of the Contract price to secure fulfillment of the Contractor's obligations specified in the Contract.
- H.6.2 A Payment Bond equal to one-hundred percent (100%) of the Contract price to protect firms or persons supplying labor or materials to the Contractor for the performance of work provided for in the Contract.
- H.6.3 Performance and Payment Bonds must be executed by surety companies licensed to do business in the State of New Jersey and listed in the U.S. Treasury Department Circular 570 as of the date for receipt of Bids.
- H.6.4 Provisions of the Performance and Payment Bonds shall not limit any liability of the Contractor to NJ TRANSIT.
- H.6.5 The Performance and Payment Bonds shall continue in full force and effect until receipt by NJ TRANSIT of Contractor affidavits of payments, debts, claims and until final Acceptance of the Work.
- H.6.6 All alterations, extensions of time, extra and additional work, and other changes authorized by the Contract Documents may be made without securing the consent of the Surety or Sureties on the Performance Bond and Payment Bond.
- H.6.7 The Performance and Payment Bonds will be paid for at the lump sum price bid therefore or at the actual cost of the Bonds to the Contractor, whichever price may be lower. Payment for the Bonds will be made only upon delivery to the Engineer of a receipted bill for the Bonds.
- H.6.8 If any Surety upon any Bond furnished in connection with this Contract becomes unacceptable to NJ TRANSIT, the Contractor shall promptly furnish such additional security as may be required from time to time to protect the interests of NJ TRANSIT and of persons supplying labor or materials in the prosecution of the Work contemplated by the Contract.

H.7 EXECUTION OF CONTRACT

Within ten (10) calendar days of receipt of a Notice of Award, the Bidder to whom the Contract is awarded shall deliver to NJ TRANSIT the Bonds, specified certificates and policies of insurance, and other specified documents required herein by NJ TRANSIT and shall properly execute two (2) copies of the Contract by signing the Contract Execution Form, as shown in Appendix C of the General Provisions. NJ TRANSIT will execute both copies of the Contract and will return one (1) copy to the Contractor.

H.7.1 This contract is subject to the provisions of N.J.S.A. 10:2-1 through 10:2-4 and N.J.S.A. 10:5-31 et seq. (P.L. 1975, c.127), and in accordance with the rules and regulations promulgated pursuant thereto, the Bidder agrees to comply with the following:

At the time the signed contract is returned to NJ TRANSIT, the Bidder that has been awarded the Contract shall submit to NJ TRANSIT and the New Jersey Department of Treasury, Division of Public Contracts, Equal Employment Opportunity Compliance and Initial Project Workforce Report (Form AA-201) consisting of forms provided by NJ TRANSIT and completed by the Contractor in accordance with Subchapter 7 of the regulations promulgated by the Treasurer pursuant to P.L. 1975, c.127. Contractors **shall comply with NJ TRANSIT's General Provisions for Construction, Article 11.2 entitled "Equal Opportunity."**

H.8 FAILURE TO EXECUTE CONTRACT

Failure of a Bidder to whom the Contract is awarded to execute the Contract or to file acceptable bonds or certificates and policies of insurance, as provided herein, shall be just cause for the annulment of the award and the forfeiture of such Bidder's Bid Security.

H.9 RELIEF OF BIDDERS

No Bidder shall be relieved of his Bid, nor shall any change be made in his Bid, because of a mistake, except as provided under applicable New Jersey Statutes and Administrative Codes.

H.10 RELEASE OF BID GUARANTEES

Within thirty (30) calendar days of Bid opening, NJ TRANSIT will release or return, as appropriate, the Bid Security of all but the two lowest responsible Bidders. The Bid Security of the two lowest Bidders shall be released or returned upon execution and

delivery of the Contract and Performance and Payment Bonds by the Bidder to whom the Contract has been awarded as required by H.6.

**I. PROTEST PROCEDURE**

I.1 PURPOSE

This section describes the policies and procedures governing the receipt and resolution of bid protests in connection with an Invitation for Bid (IFB).

I.2 DEFINITIONS

Definitions **Applicable to Instructions to Bidders, Section I, entitled "Protest Procedure"**

- a. "File" and "Submit" mean date of receipt by NJ TRANSIT's Contracting Officer.
- b. "Federal Law or Regulation" means any valid requirement imposed by Federal statute or regulation governing contracts awarded pursuant to a grant agreement between NJ TRANSIT and the FTA. This includes the requirements as stated in FTA Circular 4220.1F.
- c. "Contracting Officer" means the Chief of Procurement & Support Services or his designee as indicated in the solicitation document.
- d. **"Interested Party" means** a party that is an actual or prospective bidder or offeror whose direct economic interest would be affected by the award or failure to award the third party contract at issue.

I.3 PROCEDURE

I.3.1 Parties

Only an Interested Party may file a protest.

I.3.2 Types of Protests/Time Limits

- a. Protests based upon a challenge to the specifications or alleged improprieties in NJ TRANSIT's procurement process must be filed no later than fourteen (14) calendar days prior to the Bid opening date.
- b. Protests based upon alleged improprieties of a Bid submission shall be filed no later than five (5) business days after the apparent Bid results are posted to the Bid Express website.
- c. Protests based upon the rejection of a Bid shall be filed no later than five (5) business days after the protestor receives notification of rejection from NJ TRANSIT.
- d. Protests based upon the award of a contract shall be filed no later than five (5) business days after **receipt of NJ TRANSIT's Notice of Intent to Award.**

- e. All protests must be filed in writing. Oral protests will not be accepted.

### I.3.3 Where To File

Protests must be filed directly with NJ TRANSIT's Contracting Officer at the address below and identifying the IFB Number.

Contracting Officer  
NJ TRANSIT  
One Penn Plaza East, Sixth Floor  
Newark, NJ 07105

IFB NO.: \_\_\_\_\_

### I.3.4 The Protest

- a. The protest must contain the following information:
  - (i) The name, address and telephone number of the protestor.
  - (ii) Identity of the IFB (by number and description).
  - (iii) A statement of the specific grounds for protest and any supporting documentation. Additional materials in support of the protest will only be considered if filed within the time limits set in Paragraph I.3.2.
  - (iv) An indication of the ruling or relief desired from NJ TRANSIT.

### I.3.5 Confidentiality of Protest

Material submitted by a protestor will not be withheld from any interested party, except to the extent that the withholding of information is permitted or required by law or regulation. If the protestor considers that the protest contains proprietary material which should be withheld, a statement advising of this fact must be affixed to the front page of the protest documents and the alleged proprietary information must be so identified wherever it appears. In the event that a public request is made for materials that the protestor has identified as confidential, NJ TRANSIT shall have the sole discretion and final authority to determine whether the materials are exempt from public disclosure and shall take action as required by applicable law.

### I.3.6 Protest Procedures for I.3.2A: Challenges to a Specification

- (a) An Interested Party finding cause to challenge a specification contained within the **IFB may submit a written protest to NJ TRANSIT's Contracting Officer** setting forth in detail the grounds for such protest.

(b) A written protest may be submitted by a Bidder only after NJ TRANSIT has formally responded to any questions raised by Bidders and must be submitted at least fourteen (14) calendar days prior to the Bid opening date to permit a review of the merits of the protest and to take appropriate action, as may be necessary, prior to the scheduled deadline for proposal submission.

(c) A protest of a specification of any advertised IFB shall contain the following:

- (i) Identification of the IFB number; and
- (ii) The specification(s) at issue and the specific grounds for challenging the cited specification(s), including all arguments, materials, or other documentation in support of **the protestor's position**.

(d) **NJ TRANSIT's Contracting Officer may disregard** a protest not containing all of the items set forth in (c) above.

(e) **NJ TRANSIT's Contracting Officer may, upon timely receipt of a protest of a specification, issue a final written decision on the protest prior to the Bid opening date.** Where a decision is issued, such determination shall be a final agency decision. **NJ TRANSIT's Contracting Officer has the sole discretion to determine if** an in-person presentation by the protestor is necessary to reach an informed decision on the protest.

(f) **NJ TRANSIT's Contracting Officer may resolve a protest of a specification by** amending the IFB and extending the deadline for proposal submission, by canceling the procurement, or by any other appropriate means.

1.3.7 Protest Procedures for 1.3.2 (b), (c), and (d): Challenges to a Bid Submission, Bid Rejection or Contract Award.

(a) A protestor who finds cause to protest in accordance with Section 1.3.2 (b), (c), or (d), as set forth above, may submit a **written protest to NJ TRANSIT's Contracting Officer** setting forth in detail the grounds for such protest. All written protests must conform to the time requirements as set forth above. Failure to timely submit a protest may result in the disregard of a protest.

(b) The written protest shall contain the following information:

- (i) Identification of the IFB number;
- (ii) The specific grounds for the protest, including all arguments materials and/or **other documentation that may support the protestor's position;**
- (iii) A statement as to whether the protestor requests an opportunity for an in-person presentation and the reason(s) for the request. The opportunity for in-person presentation is at the sole discretion of the NJ TRANSIT Contracting Officer and subject to the terms of 1.3.6(c)(i) set forth below.

(iv) Failure by a protestor to include all required information may result in disregard

of the protest.

(c) Protests accepted by NJ TRANSIT shall be resolved in writing on the basis of NJ TRANSIT's **review of the record, including, but not** limited to, the written protest, the terms, conditions and requirements of the IFB, pertinent administrative rules, statutes, and case law, and any associated documentation NJ TRANSIT deems appropriate. In cases where no in-person hearing is held, the written record shall, in and of itself, constitute a hearing. The determination by NJ TRANSIT shall be a final agency decision.

(i) NJ TRANSIT has the sole discretion to determine if an in-person presentation by the protestor is necessary to reach an informed decision on the matter(s) of the protest. In-person presentations are for the benefit of NJ TRANSIT. NJ TRANSIT also has the discretion to limit attendance at an in-person presentation, when granted.

(ii) NJ TRANSIT's decision will address only the issues raised originally by the protestor.

#### I.3.8 Request for Additional Information

(a) NJ TRANSIT's **Contracting Officer, or designee**, is entitled to request, receive, and review copies of any and all records and documents deemed appropriate and relevant to the issues and arguments set forth in the protest. Upon receipt of a request by NJ TRANSIT's **Contracting Officer, or designee**, the protestor shall promptly provide the requested records and documents free of charge within the time frame specified by NJ TRANSIT.

(b) If the protesting protestor fails to comply with the provisions of this section, such failure may constitute a reasonable basis for NJ TRANSIT to resolve the protest against the protestor submitting the protest. Failure of a protestor to comply expeditiously with a request for information as specified by NJ TRANSIT's Contracting Officer, or designee, may also result in determination of the protest without consideration of the additional information.

(c) **NJ TRANSIT's Contracting Officer, or designee, may also consider** relevant information requested and received from other parties deemed appropriate by NJ TRANSIT.

#### I.3.9 Procurement Process Status

Upon timely receipt of a protest, NJ TRANSIT will delay the opening of Bids until after resolution of the protest for protests filed prior to the Bid opening, or withhold award



until after resolution of the protest for protests filed after Bid opening. However, NJ TRANSIT may open Bids or award a contract whenever NJ TRANSIT, at its sole discretion, determines that:

- a. The items or work to be procured are urgently required; or
- b. Delivery or performance will be unduly delayed by failure to make the award promptly or;
- c. Failure to make prompt award will otherwise cause undue harm to NJ TRANSIT or the Federal Government.

#### I.3.10 Federal Transit Administration (FTA) Involvement

Where procurements are funded by the FTA, the protestor may protest to the FTA only where the protest alleges that NJ TRANSIT failed to have or to adhere to its protest procedures, failed to review a complaint or protest, or violated a Federal law or regulation. Any protest to the FTA must be filed in accordance with the requirements set forth in FTA Circular 4220.1F.

**NJ TRANSIT CORPORATION**  
**INVITATION FOR BID NO. 16-042X**

**SPECIAL PROVISIONS FOR**  
**OBSERVER HIGHWAY SWITCHING HOUSE - HOBOKEN TERMINAL**  
**HOBOKEN, NEW JERSEY**

## TABLE OF CONTENTS

SP-1	INQUIRIES AND CLARIFICATIONS (B.2)	1
SP-2	PREQUALIFICATION OF BIDDERS (C.2)	1
SP-3	DBE GOAL ASSIGNMENT (C.3)	2
S.P.4	DBE FORMS AND CERTIFICATION (E.4.1)	3
SP-3	PERMITS, LAWS AND REGULATIONS (1.6)	4
SP-4	INDEPENDENT CONTRACTOR (1.8)	4
SP-5	DESCRIPTION OF WORK (1.18)	5
SP-6	TIME OF COMPLETION – DELAY – LIQUIDATED DAMAGES (2.1)	6
SP-7	NO DAMAGES FOR DELAY (2.2)	7
SP-8	USE OF PREMISES (4.2)	7
SP-9	PROTECTION AGAINST DAMAGE (4.5)	9
SP-10	PROTECTION OF PUBLIC UTILITIES (4.7)	9
SP-11	MAINTENANCE OF MARINE TRAFFIC (4.10)	9
SP-12	MAINTENANCE OF RAILROAD TRAFFIC (4.11)	9
SP-13	ARTS IN TRANSIT	10
SP-14	FIELD OFFICE AND SANITARY FACILITIES (5.2)	10
SP-15	CONSTRUCTION SIGN (5.3)	10
SP-16	CONSTRUCTION PROJECT SCHEDULE (6.2)	10
SP-17	MATERIALS-WORKMANSHIP-LABOR (7.2)	12
SP-18	INSPECTION OF WORK (7.3)	12
SP-19	NEW JERSEY PREVAILING WAGE ACT (11.1)	13
SP-20	EMPLOYEE PROTECTIONS-CONSTRUCTION ACTIVITIES (14.1)	13
SP-21	RCRA REQUIREMENTS: BUILDING INSULATION PRODUCTS AND FLY ASH IN CONCRETE (14.10)	13
SP-22	NOTICE OF EXECUTIVE ORDER 125 REQUIREMENT FOR POSTING OF WINNING PROPOSAL AND CONTRACT DOCUMENTS	13
EXHIBIT A		15

**NEW JERSEY TRANSIT CORPORATION  
SPECIAL PROVISIONS  
FOR  
OBSERVER HIGHWAY SWITCHING HOUSE – HOBOKEN TERMINAL  
  
INVITATION FOR BID NO. 16-042X**

**NOTE:** References shown thus ( ) for SP-1, SP-2, SP-3 & SP-4 refer to article numbers in the NJ TRANSIT Instructions to Bidders.

**SP-1 INQUIRIES AND CLARIFICATIONS (B.2)**

Supplement Article B.2 by adding the following:

All inquiries and requests for clarifications, shall be submitted to the NJ TRANSIT Procurement Department to the attention of:

Ms. Maggie Sotolongo  
Senior Contract Specialist  
NJ TRANSIT  
Procurement Department  
One Penn Plaza East  
Newark, NJ 07105  
Office: (973) 491-7588  
Fax: (973) 232-1892  
[msotolongo@njtransit.com](mailto:msotolongo@njtransit.com)

**SP-2 PREQUALIFICATION OF BIDDERS (C.2)**

*The following is hereby added to the end of Section II, Instruction to Bidders, Article C.2*

All General Contractors (GCs) must be prequalified by NJ TRANSIT prior to submitting a bid. All General Contractors (GCs) must be prequalified for BR (Building Construction– Rail (Operating Railroad Environment) with a minimum rating of “I” \$1,000,001 to \$2,000,000.

Prequalification questionnaires are available for download from the Bid Express website [www.bidx.com](http://www.bidx.com). Completed prequalification questionnaires must be received by NJ TRANSIT no later than seven (7) calendar days after the pre-bid conference.

The completed prequalification questionnaire shall be submitted to:

Ms. Maggie Sotolongo  
Senior Contract Specialist  
NJ TRANSIT  
Procurement Department  
One Penn Plaza East  
Newark, NJ 07105  
Office: (973) 491-7588  
Fax: (973) 232-1892  
[msotolongo@njtransit.com](mailto:msotolongo@njtransit.com)

### **SP-3 DBE GOAL ASSIGNMENT (C.3)**

*Add the following Paragraphs to Disadvantaged Business Enterprises (“DBE”) Goal Assignment (C.3) to the Instructions to Bidders:*

As an aid in meeting its commitment to the Disadvantaged Business Enterprise (DBE) Program, NJ TRANSIT has assigned a race conscious thirteen percent (13%) DBE goal on the gross sum amount of the bid or contract for DBE subcontracting participation. All NJ Unified Certification Program (NJUCP) certified DBE firms, including suppliers, are eligible to participate in this contract.

NJ TRANSIT’s DBE Program is accorded the same priority as all compliance with all other legal obligations required by the USDOT.

Contractors shall comply with the DBE Program requirements in the award and administration of NJ TRANSIT contracts. Failure by the Contractor to carry out these requirements shall constitute breach of contract, which may result in the termination of the contract or other such remedy, as NJ TRANSIT deems appropriate.

The Contractor shall refer to the DBE Requirements for Federally Funded Construction Contracts and Subcontracts included in the IFB for the requirements concerning the DBE obligations and mandatory submissions for this contract. In accordance with those requirements, the Contractor shall identify all DBE and Non-DBE subcontractors and suppliers proposed to participate in or solicited for this contract, and complete and submit the mandatory required forms (A, A1, A2, B, DBE certificate/letter and D if applicable) with their bid or within five (5) calendar days of the bid opening date. Contractors are strongly encouraged to submit these forms with the bid to prevent delay of award. These mandatory required forms shall be completed entirely with no blank fields.

Any questions regarding the DBE requirements or the mandatory required forms for this contract should be directed to Melisa Campusano, Business Development Specialist, Contract Compliance of the Office of Business Development (OBD) at (973) 491-8614.

Should the actual contract amount increase or decrease, through approved change order(s), OBD must be informed. OBD will determine if this will result in an adjustment to DBE participation to reflect the assigned DBE goal.

#### **S.P.4 DBE FORMS AND CERTIFICATION (E.4.1)**

*Add the following to Paragraph E.4.1 to the Instructions to Bidders:*

The Contractor shall refer to NJ TRANSIT's DBE Requirements for Federally Funded Construction Contracts and Subcontracts, which is included as an attachment, for instructions, guidance, and explanations for DBE program obligations under this Contract.

For this Contract, the apparent low Bidder and the second low Bidder shall identify all DBE and non-DBE subcontractors, subconsultants, and suppliers proposed to participate in and those solicited for this Contract, and shall complete and submit the mandatory DBE Forms A, A1, A2, and B. The apparent low Bidder and the second low Bidder must also submit NJ Unified Certification Program (NJUCP) certificate or letter for all potential DBE subcontractors. Additionally, the apparent low Bidder and the second low Bidder shall submit any applicable supplemental forms (AA, AA1, AA2, BB, and D). All DBE forms and NJUCP certificates or letters shall be submitted with the Bid or within five (5) calendar days of the bid opening date.

However, Bidders are strongly encouraged to submit all mandatory documents with the Bid to prevent delay of the Contract award. Bidders are requested to review carefully and complete the forms entirely, with no blank fields.

Notwithstanding the date of submission of the mandatory DBE forms, all negotiations between a Bidder and any potential DBE subcontractor, subconsultant, or supplier shall be completed prior to the bid opening date.

**Failure to submit any and all mandatory DBE documentation within five (5) calendar days of the bid opening date shall result in a rejection of a Bid as non-responsible.**

## **MODIFICATIONS TO GENERAL PROVISIONS FOR CONSTRUCTION**

**NOTE:** References shown thus ( ) for SP-5 through SP-24 refer to article numbers in the NJ TRANSIT General Provisions for Construction.

### **SP-3 PERMITS, LAWS AND REGULATIONS (1.6)**

*Supplement Article 1.6 by adding the following:*

- 1.6.10 The Contractor shall be aware that governmental agencies and bodies such as the DCA may require a significant amount of time to review, process and approve submittals, applications and permits. Consequently, the Contractor shall include time allowances in the Project Schedule as may be required because of same; and the Contractor shall be aware that further adjustments to the Contractor's Work plans may be necessary due to the aforementioned lead times.
- 1.6.11 NJ TRANSIT has obtained or will obtain the NJDCA/NJUCC Construction Permits, New Jersey Department of Environmental Protection (NJDEP) Coastal Area Facility Review Act (CAFRA) Permit, and Soil Erosion and Sediment Control (SESC) Permit for this Project. Upon award of the Contract, the Construction Manager will provide the required NJDCA Subcode forms to the Contractor, which shall be completed by the Contractor and his subcontractors in the appropriate disciplines, and returned to the Construction Manager. Once all required Subcode forms have been returned to NJ TRANSIT, the forms will be submitted to the NJDCA for processing. Any subsequent NJDCA fees incurred for reviewing Contractor-initiated modifications to the Contract design and/or issuing amended permits shall be paid by the Contractor. Any and all permit fees paid by the Contractor will be reimbursed under the Supplemental Construction allowance.

### **SP-4 INDEPENDENT CONTRACTOR (1.8)**

*Supplement Article 1.8 by adding the following:*

- 1.8.1 The scheduling of Work shall be coordinated by the Contractor with the Construction Manager. Time scheduling shall be arranged to enable all subcontractors to work at the same time, in so far as may be practical. The Contractor shall be responsible for overall construction operations at the site, and other subcontractors shall work through him in all matters involving the coordination of the various items of Work.
- 1.8.2 All coordination between the various trades and in particular between electrical work, instrumentation work, and process equipment, shall be the Contractor's responsibility, and he shall provide the services of competent

professionals to perform this coordination function including the preparation of coordination drawings which interrelate with the approved shop drawings.

## **SP-5 DESCRIPTION OF WORK (1.18)**

*Add the following new Article 1.18 to the General Provisions for Construction:*

### 1.18 Description of Work

1.18.1 The proposed Observer Highway Switching House and Remote Terminal Unit (RTU) facilities shall be constructed by the Contractor adjacent to Track 1 of the Hoboken Terminal Train Shed and the vacant, former Records Building, which are located in the City of Hoboken, County of Hudson, in the State of New Jersey. These structures will replace an existing switch house and RTU facilities, which were significantly damaged by Superstorm Sandy in October 2012, are currently located in the same area where the new facilities will be constructed.. The Observer Highway Switching House provides 13.2 kV electrical power from a PSE&G service feed to the Hoboken "Depot" Substation facility being reconstructed adjacent to the Hoboken Terminal building. The RTU facilities provide for the remote operation of the catenary disconnect switches used to sectionalize power provided to the railroad catenary system at the Hoboken Yard.

1.18.2 The Work of this Project consists of the construction of a new switch house, identified herein as the Observer Highway Switching House, and new RTU facilities to be located on a common, elevated steel platform. The existing electrical feed to the Hoboken "Depot" Substation must remain in continuous operation throughout the Project. The new Observer Highway Switching House must be installed, tested and energized, with approval by NJ TRANSIT, prior to the Contractor disconnecting any loads from the existing service feeds/equipment.

The new Observer Highway Switching House service equipment shall include a two-section, metal enclosed, weatherproof, non-walk-in housing with front access only. The first section shall include an air terminal chamber for termination of the PSE&G service cable. The second section of the switchgear shall be a fused load interrupter switch that will serve as the service-disconnecting means for the Hoboken "Depot" Substation feeder. The PSE&G overhead circuit on Observer Highway will terminate on a riser pole and continue in conduit to enter the bottom of the new switchgear.

The new RTU house shall be a factory-wired, pre-fabricated metal building manufactured in accordance the NJ TRANSIT Standard RTU House design drawings and specifications. The new RTU house shall include a SCADA RTU Cabinet, combined local control panel, AC-power automatic transfer switch, AC-power distribution breakers, main AC-power distribution panel, telecommunications equipment, telephone, interior and exterior lighting with



associated lighting control equipment, exit and emergency lighting, interior convenience power, suspended cable ladder, provisions for a small table or desk, HVAC unit with associated controls, ground bus bars, fire and security alarms, portable fire extinguisher, and appropriate accessories for the building.

The new RTU House shall also be constructed with a 125V DC battery power system including rack-mounted, sealed batteries with containment, battery charger, DC battery disconnect switch, DC-power distribution panel, emergency eye wash station, and appropriate accessories.

The RTU related Work will include the installation of electrical raceway and cabling between the new RTU House equipment and the catenary motor-operated disconnect (MOD) switches; and, demolition and removal of the existing RTU house equipment once the new RTU House is constructed, commissioned and accepted.

The new Observer Highway Switching House and RTU facilities will be located adjacent to the existing Records Building, which is a State and National Historic Register building. As such, the new switch house platform work includes installation of decorative architectural screening on several sides that has been approved by the NJ State Historic Preservation Office (SHPO).

The Project includes all demolition, architectural, structural, geotechnical, electrical, HVAC, fire protection, and plumbing work specified on the contract drawings and specifications. This Project will require NJ TRANSIT flag protection and potential track outages for certain Work. Protection and outages will be arranged and coordinated through the Construction Manager and/or the Project Manager.

1.18.3 Work, as set forth above, shall include the following:

1. Mobilization;
2. Complete removal of all demolished/cleared material;
3. Completion of all contractual Work; and,
4. Site clearing and demobilization, including removal of all materials, tools and equipment used in the completion of this Project.

## **SP-6 TIME OF COMPLETION – DELAY – LIQUIDATED DAMAGES (2.1)**

*Supplement 2.1.1 by adding the following:*

- 2.1.1a The Contractor shall pay to NJ TRANSIT the amount of \$3,000.00 as liquidated damages for each calendar day of delay in completing the Work specified by this Contract.

*Supplement 2.1.2 by adding the following:*

- 2.1.2a Time for completion for the Project shall be 450 calendar days from the effective date of the Notice to Proceed.

*Add the following new Sub-Article 2.1.14:*

- 2.1.14 All construction activities requiring NJDCA review and approval must be completed and approved with either a Certificate of Occupancy (CO) or Temporary Certificate of Occupancy (TCO) granted prior to NJ TRANSIT occupancy.

**SP-7 NO DAMAGES FOR DELAY (2.2)**

*Add the following new Sub-Article 2.2.5:*

- 2.2.5 The Contractor shall receive no additional compensation for canceled Work caused by unavailable flag men, or the need of NJ TRANSIT to perform railroad maintenance and repair Work, other than by granting the Contractor time added to the approved Project schedule. The approval of additional time shall be determined at the sole discretion of NJ TRANSIT.

**SP-8 USE OF PREMISES (4.2)**

*Add the following to Sub-Article 4.2.1:*

The Contractor fully acknowledges that the Work described in this contract will occur at an active and congested rail terminal, adjacent to active tracks with overhead electrical catenary work, a high-traffic roadway serving as a main access point for the City of Hoboken and the Hudson Bus Terminal, and busy pedestrian access ways; that the site contains very limited laydown areas for construction staging and storage; and, that the Contractor's access to and use of the premises may be restricted by NJ TRANSIT's equipment, material and/or personnel, which are required to ensure continued NJ TRANSIT operation, safety and security.

If the Contractor's access to or use of the Project site is restricted, the Contractor shall be given additional time only, in accordance with Article 2.2 of the General Provisions for Construction.

The Contractor shall maintain site access for all essential services including, but not limited to, NJ TRANSIT operations, ferry operations, police and security activities, emergency services, and garbage collection and/or disposal during all construction activities.

The Contractor shall not interfere with or hinder daily operations at the subject Project site for any NJ TRANSIT maintenance equipment and/or personnel; and the Contractor shall coordinate and schedule construction activities with the NJ TRANSIT Construction Manager and/or Project Manager.

The failure or inability of NJ TRANSIT to provide previously-approved storage and staging areas shall not entitle the Contractor to additional compensation, damages or time.

*Add the following new Sub-Article 4.2.10:*

- 4.2.10 Adjacent to the Work site are ACTIVE terminal tracks with trains entering and leaving the station through all hours of the day and night. The Contractor shall allow sufficient time to move personnel, equipment and/or materials back to any approved construction staging areas.

*Add the following new Sub-Article 4.2.11:*

- 4.2.11 No fouling of any tracks will be permitted unless under the direct supervision of the required NJ TRANSIT flagman, and only after all Contractor and/or subcontractor personnel have been NJ TRANSIT safety trained. Rail Safety Training shall be arranged and scheduled in advance of the commencement of Work through either the NJ TRANSIT Construction Manager or Project Manager. Refer to Sub-Article 4.2.13 below.

*Add the following new Sub-Article 4.2.12:*

- 4.2.12 The Contractor shall submit a detailed Site Specific Work Plan (SSWP) to NJ TRANSIT for review and approval prior to commencement of ANY work. The SSWP must include all material and equipment staging plans, storage/trailer locations, and security procedures; and, ensure conformance with railroad loading for installed materials, either permanent or temporary. Allow a minimum of forty-five (45) calendar days for **SSWP review**.

*Add the following new Sub-Article 4.2.13:*

- 4.2.13 Within ten (10) calendar days after Notice to Proceed the Contractor shall make arrangements through the Construction Manager for Rail Safety Training. All Contractor on-site personnel must attend Rail Safety Training and have a current sticker on their hard hat and identification card on their person in their possession at all times and be prepared to present such identification upon request before the Contractor will be allowed to work at the Project site.

**NOTE: The Contractor shall not be compensated for safety violation related site shutdowns.**

## **SP-9 PROTECTION AGAINST DAMAGE (4.5)**

*Add the following to Sub-Article 4.5.2:*

The Contractor shall ensure that no damage(s) occurs to any station, track, parking elements or other NJ TRANSIT property, which is not specifically contemplated for as part of the Work in this Contract. If there is any damage to the station, track, parking, or other NJ TRANSIT property which are beyond the scope of this Contract, the Contractor shall have the sole expense and sole responsibility to make repairs, to the satisfaction of NJ TRANSIT, and will not be compensated by NJ TRANSIT.

*Supplement Article 4.5 by adding the following:*

- 4.5.8 The Contractor shall protect the contract Work, including all construction in progress, completed construction, materials and equipment. Protection shall include, but not be limited to, installation of substantial temporary enclosures or buildings providing strong locking entrances to prevent unauthorized entrance, vandalism, theft or other such violations.
- 4.5.9 The Contractor shall prohibit entry to the Project area by unauthorized personnel during both working and non-working hours. The Contractor shall not rely upon existing security measures in place by NJ TRANSIT for the protection of the Contractor's equipment, materials and personnel since such security measures are for the sole protection of NJ TRANSIT passengers, employees, equipment and existing facilities. The Contractor shall coordinate all of its own security measures through the Construction Manager.

## **SP-10 PROTECTION OF PUBLIC UTILITIES (4.7)**

*Supplement the second paragraph of Sub-Article 4.7.1 by inserting the following sentence:*

The Contractor shall use the New Jersey One-Call System at (800) 272-1000 to check for underground utilities and to arrange for markouts.

## **SP-11 MAINTENANCE OF MARINE TRAFFIC (4.10)**

*Delete Article 4.10 in its entirety.*

## **SP-12 MAINTENANCE OF RAILROAD TRAFFIC (4.11)**

*Supplement Sub-Article 4.11.1 by adding the following:*

- 4.11.1.1 The Contractor shall notify the Construction Manager in writing at least three (3) weeks prior to any requested track fouling and obtain the Construction

Manager's express approval before proceeding with the Work. In addition, the request for a flagman shall be submitted 48 hours in advance and must be accompanied by a detailed Work plan. The plan shall indicate specific Work locations and said Work to be performed.

### **SP-13 ARTS IN TRANSIT**

*Delete article 4.13 in its entirety.*

### **SP-14 FIELD OFFICE AND SANITARY FACILITIES (5.2)**

*Add the following to the end of Sub-Article 5.2.7:*

Provide necessary desktop computers, fax machines, printers, internet connections, software, phone lines and fax lines (as determined by NJ TRANSIT) paid for in the Field Office allowance item.

*Delete the last paragraph from Article 5.2.9.*

### **SP-15 CONSTRUCTION SIGN (5.3)**

*Delete and replace the first sentence of Article 5.3 to read as follows:*

The Contractor shall fabricate and install construction sign(s) as indicated in the NJ TRANSIT Sign Standards Manual – Section 7.0 Temporary Signs (see attached manual excerpt entitled Exhibit A). Sign selection and location shall be made by the Construction Manager. Cost of the construction signs shall be included in the line item for "Project Mobilization."

### **SP-16 CONSTRUCTION PROJECT SCHEDULE (6.2)**

*Add the following to Article 6.2.1:*

The Contractor shall employ a scheduler specializing in CPM scheduling with a minimum of approximately five (5) years documented experience. The Contractor shall provide a coordinated Project schedule, for review and approval by NJ TRANSIT, generated using Primavera, latest release, or scheduling software that is fully compatible with it, as approved by the Construction Manager.

The coordinated schedule shall list all activities in sorts or groups:

- A. By preceding work item or event number from lowest to highest.
- B. By amount of float, then in order of early start date.
- C. By responsibility in order of earliest possible start date.
- D. In order of latest allowable start dates.
- E. In order of latest allowable finish dates.

- F. Listing of basic input data which generates the report.
- G. Listing of activities on the critical path.

All milestone dates shall be provided with the schedule for all major activities.

*Add the following to Article 6.2.6:*

The Contractor will plan for and schedule a Bi-Weekly Construction Meeting with the Resident Engineer, Construction Manager and/or Project Manager to update the Detailed Project Schedule (DPS) and review any logic revisions.

The updated DPS shall include the actual start date, percentage complete, and remaining duration or actual finish date for each activity in progress as well as any proposed schedule revisions such as the addition on new activities, change to the logic and/or duration of the existing activities.

The Contractor shall attach the updated DPS to a progress narrative that discusses the progress made during the current period, the impact of the progress on the milestone dates, the status of the critical path activities, the Work planned for the following period, any anticipated problems, the resolution to previously noted problems and the means of recovering the DPS should the Project fall behind.

Resultant of the update meeting, the Contractor shall submit an updated DPS to the Construction Manager each month with the Contractor's application for payment, which must be submitted by the 25 day of each month. Delayed payment applications will result in delayed payment.

*Add the following Article 6.2.16:*

- 6.2.16 Failure to submit the DPS in accordance with this Provision, or failure by the Contractor to attend and participate in scheduled update meetings, shall be sufficient cause for NJ TRANSIT to take the appropriate action to remedy the failures.

*Add the following Article 6.2.17:*

- 6.2.17 The Contractor's DPS shall include a period of one (1) week duration, immediately prior to Substantial Completion, for the Construction Manager to perform a final inspection of the Work and to prepare the list of Remaining Work which is incorporated into the Certificate of Substantial Completion (4.18.2). The Work must be sufficiently complete, prior to this activity, for the Construction Manager to perform this inspection.

## **SP-17 MATERIALS-WORKMANSHIP-LABOR (7.2)**

*Supplement Article 7.2 by adding the following:*

- 7.2.10 The Contractor assumes all the responsibility and liability associated with ensuring that all workers in its employment, or that of its subcontractors, have the capacity to fully understand all verbal and written training, instructions and commands given to them by NJ TRANSIT safety, security and supervisory personnel. The Contractor shall immediately remove and replace all workers who fail to strictly and completely comply with all NJ TRANSIT training, instructions and commands, with no exceptions.
- 7.2.11 The Contractor shall submit to NJ TRANSIT, within ten (10) days of the bid opening, a detailed resume citing the name, training and experience of the proposed project superintendent designated for assignment on this Contract.

The project superintendent shall be a competent, English-speaking individual to be employed on this Project full time and to be present on the Work site to direct and supervise the Work on each day and every workday that Work is being performed, from the start of the Work to the acceptance of the same.

The Project Superintendent shall be empowered by the Contractor to make binding decisions in a timely manner; and, shall be an individual with a minimum ten (10) years of supervisory experience on construction projects of a similar type and complexity. A list of three (3) references from past (recent) projects shall be furnished. The Project Superintendent shall have a demonstrated record of successfully supervising and have a reputation as cooperative and responsive to clients in the opinion of the client reference.

- 7.2.12 The Contractor shall submit the required personnel information to propose a project superintendent that meets the aforementioned minimum qualifications.

## **SP-18 INSPECTION OF WORK (7.3)**

*Supplement Article 7.3 by adding the following:*

- 7.3.8 The Contractor shall recognize the necessity to schedule regulatory and code enforcement inspections well in advance and make all reasonable accommodations necessary to facilitate said inspections so as to avoid delay in progressing or completing the Work. Furthermore, the Contractor shall realize that even scheduled inspections may be cancelled by the regulatory and code enforcement agencies without advance notice.

7.3.9 The Contractor shall not receive additional time or compensation for untimely lack of responsiveness and associated delay caused by a regulatory or code enforcement agency, unless said delay exceeds that which is normally and customarily experienced by others when interfacing with said agency. If such a delay occurs, the Contractor shall be granted additional time only for the portion of the delay which exceeds the response time ordinarily and typically experiences with the specific agency under similar circumstances.

### **SP-19 NEW JERSEY PREVAILING WAGE ACT (11.1)**

*In Section IV, General Provisions For Construction, Article 11. Social and Economic Requirements, Sub-Article 11.1, add the following:*

Attached is the New Jersey Department of Labor Prevailing Wage Rate Determination.

### **SP-20 EMPLOYEE PROTECTIONS-CONSTRUCTION ACTIVITIES (14.1)**

*In Section IV, General Provisions For Construction, Article 14. Federal Provisions, Sub-Article 14.1, add the following:*

Attached is the General Wage Determination dated November 4, 2016.

### **SP-21 RCRA REQUIREMENTS: BUILDING INSULATION PRODUCTS AND FLY ASH IN CONCRETE (14.10)**

*Modify Sub-Article 14.10.2 to read as follows:*

No cement used on this Project shall contain any fly ash.

### **SP-22 NOTICE OF EXECUTIVE ORDER 125 REQUIREMENT FOR POSTING OF WINNING PROPOSAL AND CONTRACT DOCUMENTS**

Pursuant to Executive Order No. 125, signed by Governor Christie on February 8, 2013, the Office of the State Comptroller ("OSC") is required to make all approved State contracts for the allocation and expenditure of federal reconstruction resources available to the public by posting such contracts on an appropriate State website. Such contracts are posted on the New Jersey Sandy Transparency website located at: <http://nj.gov/comptroller/sandytransparency/contracts/sandy/>

The contract resulting from this IFB is subject to the requirements of Executive Order No. 125. Accordingly, the OSC will post a copy of the contract, including the IFB, the winning bidder's proposal and other related contract documents for the above contract on the Sandy Transparency website.



In submitting its proposal, a bidder may designate specific information as not subject to disclosure. However, such bidder must have a good faith legal and/ or factual basis to assert that such designated portions of its proposal (i) are proprietary and confidential financial or commercial information or trade secrets or (ii) must not be disclosed to protect the personal privacy of an identified individual. The location in the proposal of any such designation should be clearly stated in a cover letter, and a redacted copy of the proposal should be provided.

The State reserves the right to make the determination as to what is proprietary or confidential, and will advise the winning bidder accordingly. The State will not honor any attempt by a winning bidder to designate its entire proposal as proprietary, confidential and/or to claim copyright protection for its entire proposal. In the event of any challenge to the winning bidder's assertion of confidentiality with which the State does not concur, the bidder shall be solely responsible for defending its designation.

**END OF SPECIAL PROVISIONS**

## Sign Type 7.1

Project Site Signs - NJT/STATE Sign Detail

### General Specifications

**Materials:**  
 1- Panel: 3/4" thick marine grade plywood  
 2- Posts: 4"x4" pressure treated wood

### Colors & Finishes:

- 1- Panel:  
 e- Header: White, painted  
 f- Message Panel: Black, painted  
 g- Type: White, painted, or vinyl  
 5- NJ TRANSIT signature: Chevron  
 a- Orange, silkscreened or vinyl  
 b- Magenta, silkscreened or vinyl  
 c- Blue, silkscreened or vinyl  
 Symbol & logo  
 d- Black, silkscreened, painted or vinyl.

**Fabrication:** •See Detail 1.7

**Installation:** •See Detail 3.2 (direct burial)

**Copy:**  
 •Header: Use NJ TRANSIT signature-obtain camera-ready artwork from NJ TRANSIT Passenger Facilities Department  
 •Message Panel: Helvetica Medium upper and lower case



EXHIBIT A

**NEW JERSEY TRANSIT CORPORATION**  
**GENERAL PROVISIONS FOR CONSTRUCTION**

**Table of Contents**

1.	GENERAL REQUIREMENTS	1
1.1	ABBREVIATIONS AND DEFINITIONS .....	1
1.2	ORDER OF PRECEDENCE .....	7
1.3	REFERENCED STANDARDS .....	7
1.4	INTENTION .....	8
1.5	INTERPRETATION .....	9
1.6	PERMITS, LAWS, AND REGULATIONS .....	10
1.7	FEDERAL, STATE, AND LOCAL TAXES .....	11
1.8	INDEPENDENT CONTRACTOR .....	12
1.9	ASSIGNING AND SUBCONTRACTING CONTRACT .....	12
1.10	CONTRACTING OFFICER'S AUTHORITY .....	14
1.11	PROJECT MANAGER'S AUTHORITY .....	14
1.12	CONSTRUCTION MANAGER'S AUTHORITY .....	14
1.13	INSPECTOR'S AUTHORITY .....	14
1.14	NOTICE AND COMMUNICATION .....	15
1.15	DISPUTES .....	15
1.16	GOVERNING LAW; CONSENT TO JURISDICTION AND WAIVER OF TRIAL BY JURY .....	15
1.17	AUDIT AND INSPECTION OF RECORDS .....	16
2.	CONTRACT TIME, SUSPENSION AND TERMINATION	17
2.1	TIME OF COMPLETION - DELAY - LIQUIDATED DAMAGES .....	17
2.2	NO DAMAGES FOR DELAY .....	20
2.3	SUSPENSION OF WORK .....	21
2.4	TERMINATION FOR CONVENIENCE .....	21
2.5	TERMINATION FOR CAUSE .....	25
3.	CONTRACT CHANGES	26
3.1	CHANGE ORDERS .....	26
3.2	CHANGE ORDER PRICING .....	28
3.3	TIME AND MATERIAL (T&M) CHANGE ORDER RECORDS .....	35
3.4	CONTRACTOR INITIATED CHANGE ORDERS .....	36
3.5	AUDIT OF CHANGE ORDERS .....	37
3.6	SUPPLEMENTAL CONSTRUCTION COSTS .....	39
4.	PROTECTION AND CONTROL OF PREMISES	39
4.1	RESPONSIBILITY FOR WORK .....	39
4.2	USE OF PREMISES .....	40
4.3	MAINTENANCE AND CLEANING OF PREMISES .....	41
4.4	FIRE PREVENTION ON PREMISES .....	42
4.5	PROTECTION AGAINST DAMAGE .....	43
4.6	PROTECTION OF PRIVATE PROPERTY .....	44
4.7	PROTECTION OF PUBLIC UTILITIES .....	44
4.8	PROTECTION OF EXISTING MONUMENTS .....	45
4.9	MAINTENANCE AND PROTECTION OF ROADWAY AND PEDESTRIAN TRAFFIC .....	46
4.10	MAINTENANCE OF MARINE TRAFFIC .....	47
4.11	MAINTENANCE OF RAILROAD TRAFFIC .....	47
4.12	WORK FURNISHED BY OTHERS .....	53
4.13	ARTS IN TRANSIT .....	53
5.	MOBILIZATION AND TEMPORARY FACILITIES	54
5.1	MOBILIZATION .....	54
5.2	FIELD OFFICE AND SANITARY FACILITIES .....	56
5.3	CONSTRUCTION SIGN .....	59
5.4	TEMPORARY WATER .....	59
5.5	TEMPORARY LIGHT AND POWER .....	60
5.6	TEMPORARY HEAT .....	60
5.7	TEMPORARY PARTITIONS, ENCLOSURES, GLAZING BREAKAGE AND CLEANING .....	62
5.8	TEMPORARY, INTERMEDIATE AND HIDDEN WORK .....	62
5.9	DEMOBILIZATION .....	63
6.	PROJECT ADMINISTRATION AND DOCUMENT CONTROL	63

**NEW JERSEY TRANSIT CORPORATION**  
**GENERAL PROVISIONS FOR CONSTRUCTION**

**Table of Contents**

6.1	PROJECT MEETINGS.....	63
6.2	CONSTRUCTION PROJECT SCHEDULE .....	65
6.3	CONTRACT DRAWINGS AND SPECIFICATIONS .....	69
6.4	GENERAL REQUIREMENTS FOR SUBMITTALS .....	70
6.5	SHOP AND WORKING DRAWING SUBMITTALS.....	72
6.6	SAMPLES SUBMITTALS.....	75
6.7	PRODUCT AND SUBMITTALS.....	75
6.8	VALUE ENGINEERING SUBMITTALS .....	78
6.9	PROGRESS PHOTOGRAPH SUBMITTALS .....	79
6.10	REPORTS, RECORDS AND DATA SUBMITTALS .....	80
6.11	AS-BUILT DRAWINGS AND QUANTITIES SUBMITTAL.....	80
7.	QUALITY ASSURANCE AND QUALITY CONTROL .....	81
7.1	QUALITY ASSURANCE.....	81
7.2	MATERIAL - WORKMANSHIP - LABOR.....	82
7.3	INSPECTION OF WORK .....	84
7.4	PLANT INSPECTION.....	85
7.5	INSTALLED EQUIPMENT TESTING AND TRAINING .....	85
7.6	LABORATORY TESTING AND INSPECTION .....	86
7.7	CERTIFICATION OF COMPLIANCE .....	89
7.8	NON-CONFORMING WORK AND MATERIALS .....	90
7.9	WARRANTY AGAINST DEFECTIVE WORK.....	91
8.	EXCAVATION AND DIFFERING SITE CONDITIONS .....	92
8.1	UNCLASSIFIED EXCAVATION .....	92
8.2	MEASUREMENT OF PAY LIMITS FOR EXCAVATION.....	92
8.3	SOIL BORINGS.....	92
8.4	DIFFERING, LATENT OR UNUSUAL SITE CONDITIONS.....	92
8.5	ARCHEOLOGICAL FINDINGS .....	93
9.	INDEMNIFICATION AND LIABILITY .....	93
9.1	INDEMNIFICATION; RISKS ASSUMED BY THE CONTRACTOR .....	93
9.2	INSURANCE .....	96
9.3	LIMITATIONS OF LIABILITY.....	99
9.4	NO THIRD PARTY BENEFICIARIES .....	99
9.5	PERSONAL LIABILITY OF PUBLIC OFFICIALS .....	99
9.6	INTELLECTUAL PROPERTY .....	99
9.7	ENVIRONMENTAL COMPLIANCE AND LIABILITY .....	100
10.	ETHICAL REQUIREMENTS .....	101
10.1	COVENANT AGAINST CONTINGENT FEES .....	101
10.2	OFFICIALS NOT TO BENEFIT .....	101
10.3	GRATUITIES.....	101
10.4	NJ TRANSIT CODE OF ETHICS .....	102
11.	SOCIAL AND ECONOMIC REQUIREMENTS .....	103
11.1	NEW JERSEY PREVAILING WAGE ACT .....	103
11.2	EQUAL OPPORTUNITY .....	104
11.3	UTILIZATION OF DISADVANTAGED BUSINESS ENTERPRISES.....	111
12.	MEASUREMENT AND PAYMENT .....	112
12.1	SCOPE OF PAYMENT.....	112
12.2	QUANTITIES: MEASUREMENT AND PAYMENT .....	112
12.3	PARTIAL PAYMENTS.....	113
12.4	MATERIALS PAYMENTS .....	114
12.5	RETAINAGE .....	115
12.6	SUBCONTRACTOR PAYMENTS AND RETAINAGE .....	115
12.7	PAYMENTS WITHHELD.....	117
12.8	FINAL PAYMENT.....	117
12.9	SETTING OFF TAX ARREARS AGAINST SUMS OWED .....	119
13.	ACCEPTANCE AND COMPLETION .....	120
13.1	PARTIAL ACCEPTANCE.....	120

**NEW JERSEY TRANSIT CORPORATION**  
**GENERAL PROVISIONS FOR CONSTRUCTION**

**Table of Contents**

13.2	SUBSTANTIAL COMPLETION .....	120
13.3	COMPLETION AND FINAL ACCEPTANCE OF THE WORK .....	121
14.	FEDERAL PROVISIONS .....	122
14.1	EMPLOYEE PROTECTIONS-CONSTRUCTION ACTIVITIES .....	122
14.2	CLEAN WATER AND CLEAN AIR ACTS .....	130
14.3	BUY AMERICA.....	131
14.4	FLY AMERICA REQUIREMENTS.....	131
14.5	CARGO PREFERENCE - USE OF U.S. FLAG VESSELS .....	131
14.6	ENERGY CONSERVATION .....	132
14.7	CONTRACT WORK HOURS AND SAFETY STANDARDS .....	132
14.8	CIVIL RIGHTS.....	132
14.9	PATENT RIGHTS.....	134
14.10	RCRA REQUIREMENTS: BUILDING INSULATION PRODUCTS AND FLY ASH IN CONCRETE.....	134
14.11	FEDERAL EEO PROVISIONS FOR CONSTRUCTION CONTRACTS.....	137
14.12	LIMITATIONS ON LOBBYING .....	146
14.13	SEISMIC SAFETY.....	147
14.14	EXCLUSIONARY OR DISCRIMINATORY SPECIFICATIONS .....	147
14.15	NO FEDERAL GOVERNMENT OBLIGATIONS TO THIRD PARTIES .....	147
14.16	FALSE OR FRAUDULENT STATEMENTS AND CLAIMS .....	147
14.18	FEDERAL AID, LAWS AND REGULATIONS.....	148

*APPENDIX A – SUBCONTRACTOR EVALUATION DATA FORM*

*APPENDIX B – CLOSEOUT FORMS*

*APPENDIX C – CONTRACT EXECUTION FORM*

*APPENDIX D – GOVERNING RULES FOR WORKING WITHIN THE RAILROAD RIGHT OF WAY*

*APPENDIX E – AGREEMENT BETWEEN CONTRACTOR AND ARTIST*

**NEW JERSEY TRANSIT CORPORATION**  
**GENERAL PROVISIONS FOR CONSTRUCTION**

**1. GENERAL REQUIREMENTS**

1.1 ABBREVIATIONS AND DEFINITIONS

1.1.1 ABBREVIATIONS:

<u>AAR</u>	Association of American Railroads
<u>AASHTO</u>	American Association of State Highway and Transportation Officials
<u>AMTRAK</u>	National Railroad Passenger Corporation
<u>ANSI</u>	American National Standards Institute (Formerly USASI, United States of American Standards Institute, and ASA, American Standard Association)
<u>AREMA</u>	American Railway Engineering and Maintenance Association (Formerly AREA, American Railway Engineering Association)
<u>ASTM</u>	American Society for Testing and Materials
<u>CONRAIL</u>	Consolidated Rail Corporation
<u>CFR</u>	Code of Federal Regulations
<u>CPM</u>	Critical Path Method
<u>DCA</u>	New Jersey Department of Community Affairs
<u>FTA</u>	Federal Transit Administration
<u>IOM</u>	Integrity Oversight Monitor
<u>MSDS</u>	Material Safety Data Sheet(s)
<u>NFPA</u>	National Fire Protection Association
<u>NJAC</u>	New Jersey Administrative Code
<u>NJDOT</u>	New Jersey Department of Transportation
<u>NJUFC</u>	New Jersey Uniform Fire Code
<u>NJ TRANSIT</u>	New Jersey Transit Corporation
<u>NJUCC</u>	New Jersey Uniform Construction Code
<u>NPC</u>	Notice of Proposed Change
<u>OSHA</u>	Occupational Safety and Health Administration, and Occupational Safety and Health Act of 1970, and amendments thereto; United States Department of Labor
<u>PMO</u>	Project Management Oversight
<u>RFI</u>	Request for Information
<u>USDOT</u>	United States Department of Transportation

1.1.2 DEFINITIONS:

Acceptance of the Work: The act of the Contracting Officer, or the Contracting Officer's authorized representative, by which NJ TRANSIT accepts the work performed as partial or complete performance of the requirements of the Contract on the part of the Contractor.

Addendum (plural Addenda): Written interpretations, clarifications, and revisions to any of the Contract Documents issued by NJ TRANSIT before the Bid opening.

Advertisement: The public announcement, as required by law, inviting Bids for work to be performed, materials to be furnished, or both.

Affiliate: Any entity that (1) directly, indirectly, or constructively controls another entity, (2) is directly, indirectly, or constructively controlled by another entity, or (3) is subject to the control of a common entity. An entity controls another entity if it owns, directly or individually, more than 50% of the ownership in that entity.

Allowance: An item included in the Bidder's Proposal for the exclusive use and benefit of NJ TRANSIT.

Approved Equal: A product which, in the opinion of the Engineer, complies with the technical specification requirements in form, fit, functionality, maintainability, useful life and quality of performance.

Approval: The written endorsement, sanction, or authorization by NJ TRANSIT of a proposal, plan, procedure, action, document, report, specification, design, or any part thereof, undertaken, promulgated, or developed by the Contractor in accordance with the indicated requirements of the Contract.

Architect: The term Architect shall be used interchangeably with Engineer and shall have the same meaning as Engineer.

Award: The approval by NJ TRANSIT of the Bid and written notice of same to the tenderer of said Bid.

Bid: The proposal or offer of the Bidder for the Work, when made out and submitted on the prescribed Bid Forms, properly signed, dated, and guaranteed, and which includes the schedule of Bid Items.

Bid Security: The Bid bond, cashier's check, certified check or irrevocable letter of credit accompanying the Bid submitted by the Bidder guaranteeing that the Bidder will enter into a Contract with NJ TRANSIT for the performance of the Work indicated and will provide acceptable bonds and insurance if the Contract is awarded to it.

Bidder: An individual, firm, partnership, corporation, joint venture or combination thereof submitting a proposal for the Work contemplated as a single business entity and acting directly or through a duly authorized representative.

Bidder's Proposal: The prescribed Bid Form which contains the schedule of Bid Items and the Bidder's declaration to perform the work for the prices bid.

Business Organization: An individual, partnership, association, joint stock company, trust, corporation, or other legal business entity or successor thereof.

Business Registration: A business registration certificate issued by the Department of the Treasury or such other form or verification that a Contractor or Subcontractor is registered with the Department of Treasury.

Calendar Day: Each and every day shown on the calendar.

Change Order: A written order issued by the Contracting Officer of NJ TRANSIT to the Contractor delineating changes in the Contract Documents in conjunction with one or more Notice(s) of Proposed Change and establishing, if appropriate, an equitable adjustment to the Contract Price or Contract Time for the work affected by the change(s).

Construction Equipment: All machinery and equipment, together with the necessary supplies for upkeep and maintenance, and also tools and apparatus necessary for the proper and acceptable completion of the Work.

Construction Manager: NJ TRANSIT's Assistant Executive Director (AED) of Capital Planning and Programs acting, directly or through the AED's authorized representatives at the Construction Site, within the scope of duties assigned to him or her.

Construction Site: The geographical area of the property at which the contract work is performed, as authorized and identified by NJ TRANSIT.

Consultant: A firm or individual contracting with and providing professional services to NJ TRANSIT.

Contract: The written agreement executed by the Contracting Officer of NJ TRANSIT and the Contractor which covers the performance of the Work, the furnishing of labor, materials, tools and equipment and the basis of payment, and which incorporates the various Contract Documents. The Contract represents the entire and integrated agreement between the parties and supersedes all prior negotiations, representations or agreements either written or oral.

Contract Documents: The Contract Documents include: The General Provisions for Construction, Special Provisions, Technical Provisions, Contract Drawings, Contract Forms, Documents referenced by these specifications, the Notice(s) to Proceed, Directive Letters, Change Orders, and Addenda.

Contract Drawings: The official plans, sections, elevations and details in the Contract Documents or amendments thereto and supplemental drawings approved by NJ TRANSIT which show the locations, character, dimensions and details of the Work to be performed.

Contract Item (Pay Item): A specifically described product or unit of work for which a price is listed in the Contract or the Bidder's Proposal.

Contractor Initiated Change Order Request (CICOR): A request submitted to NJ TRANSIT by the Contractor specifying a proposed addition, deduction, or change to the Contract Documents.

Contract Limit: The lines shown on the drawings beyond which no construction work shall be performed unless otherwise noted on the drawings or in the specifications.

Contract Time: The number of calendar days or specified date set forth in the Contract for substantial completion of the Work, including amendments authorized by Change Order thereto; also referred to as Time of Completion. Contract Time begins on the date of the Notice to Proceed which is day one (1) of the Contract Time.

Contracting Officer: NJ TRANSIT's Chief of Procurement & Support Services acting, directly or through the Chief of Procurement & Support Services authorized representative(s), within the scope of duties assigned to him or her.

Contractor: The individual, firm, partnerships, corporation, joint venture, or any combination thereof, who, as an independent contractor, has entered into a Contract with NJ TRANSIT, as party or parties of the second part and who is referred to throughout the Contract Documents by singular number and non-specific gender.

Days: Days as used in the Specifications shall be understood to mean calendar days unless otherwise designated.



Directive Letter: A letter issued by the Contracting Officer, or the Contracting Officer's duly authorized designee, directing the Contractor to proceed with added, deleted or changed work.

Drawings: See Contract Drawings.

Engineer: The authorized representative of NJ TRANSIT providing design and engineering services for the Project. This may be either internal NJ TRANSIT staff or an outside consultant.

Execution of the Contract: The signing of the Contract by the authorized representative of NJ TRANSIT and the authorized representative of the Contractor.

Executive Director: The chief executive officer of NJ TRANSIT appointed in accordance with N.J.S.A. 27:25-1 et seq. and NJ TRANSIT's by-laws, or his/her designee.

Extra Work: An item of work not provided for in the Contract as awarded but found essential to the acceptable completion of the Contract within its intended scope.

Failure: Inability of a component, equipment, or system to function or perform in accordance with the indicated requirements.

Federal Transit Administration: Formerly known as the Urban Mass Transportation Administration, an agency within the United States Department of Transportation.

Final Inspection: The inspection conducted by the Project Manager to determine if the Work, or any substantial portion thereof, declared by the Contractor to be completed, has been satisfactorily completed in accordance with the requirements of the Contract and Contract Documents, and properly conditioned for final acceptance by the Contracting Officer.

Form, Fit, and Function: The technical documentation describing the physical and functional characteristics of an item as an entity, but not including any characteristics of the elements making up the item.

General Provisions: The general conditions of the Contract set forth in the Contract Documents as the General Provisions for Construction.

Government: The Government of the United States of America.

Holidays: Specific days on which NJ TRANSIT is not open for business.

Inspector: The Construction Manager's authorized representative assigned to observe Contract performance and materials furnished by the Contractor.

Installed Equipment: Equipment incorporated into the Work under this Contract.

Installer: The Contractor or entity (person or firm) engaged by the Contractor or its Subcontractor at any tier for the performance of a particular unit of work at the project site, including installation, erection, application and similar required operations.

Integrity Oversight Monitor: A private entity that contracts to provide specialized services to ensure legal compliance, detect misconduct, and promote best practices in the administration of recovery and rebuilding projects, which services may include, but should not be limited to, legal, investigative, accounting, forensic accounting, engineering, other professional specialties, risk assessment, developing compliance system constructs, loss prevention, monitoring, contract managers and independent private inspectors general.

Invitation for Bids: The set of documents issued by NJ TRANSIT's Procurement Department for the purpose of soliciting Bids.

Joint Venture: A legal association of Contractors formed for the purpose of bidding and executing a Contract as a single business entity.

Logo: An abbreviation for logotype, trademark or symbol.

Materials: Substances specified for use in the Work and its appurtenances.

NJ TRANSIT: A public instrumentality of the State of New Jersey established by the New Jersey Public Transportation Act, N.J.S.A. 27:25-1 et seq. (L. 1979, c.150).

Notice of Proposed Change (NPC): A notice issued to the Contractor by NJ TRANSIT specifying a proposed addition, deduction or change to the Contract Documents. A Notice of Proposed Change is not an order to incorporate revisions into the Work.

Notice(s) to Proceed: The written directive from the Contracting Officer to the Contractor authorizing the Contractor to begin the prosecution of the Work in the initial Contract or for added, deleted or changed Work.

Owner: The New Jersey Transit Corporation (NJ TRANSIT).

Performance and Payment Bonds: The approved form of security furnished by the Contractor and its surety guaranteeing complete performance of the Contract in conformity with the Contract Documents and the payment of legal obligations pertaining to the construction of the Contract.

Project: The specific Work required to be performed by the Contractor as described in the Contract Documents.

Project Data: Illustrations, standard schedules, performance charts, instructions, brochures, diagrams, performance and test data, test procedures, existing drawings, operational manuals, maintenance manuals, spare parts lists and data, descriptive literature, catalogs, catalog cuts, and other information furnished by the Contractor to illustrate a material, product or equipment and to support its test, installation, operation or maintenance.

Project Management Oversight: Continuous review and evaluation of grantees and FTA processes to ensure compliance with federal, state and local statutory, administrative and regulatory requirements.

Project Manager: NJ TRANSIT's Assistant Executive Director (AED) of Capital Planning and Programs or Deputy General Manager (DGM) of Infrastructure Design acting, directly or through their authorized representative(s), within the scope of the particular duties assigned to him or her.

Proposal: See Bid.

Purchase Order: The written document generated by the Procurement Department and issued to the Contractor for billing purposes.

Quotation: The Contractor's written response to the Notice of Proposed Change.

Reliability: The probability that equipment or a system will perform its intended functions without failure and within design parameters under specified operating conditions for which designed and for a specific period of time.

Remaining Work: Any and all Work remaining to be performed after Substantial Completion, including but not limited to, punch list work, which in the opinion of the Engineer is necessary for full conformance to the Contract.

Samples: Physical examples which illustrate materials, equipment or workmanship and establish standards by which the acceptability of the Work will be judged.

Shop Drawings: Original drawings, submitted to the Construction Manager by or through the Contractor, Subcontractor or any lower tier Subcontractor pursuant to the Work, including, but not limited to: stress sheets, working drawings, diagrams, illustrations, schedules, performance charts, brochures, erection plans, falsework plans, framework plans, cofferdam plans, bending diagrams for reinforcing steel, reinforced concrete formwork drawings, or other supplementary plans or similar data which are prepared by the Contractor or a Subcontractor, manufacturer, supplier or distributor, and which the Contractor is required to submit to the Construction Manager for review and approval by the Engineer.

Special Provisions: Special Provisions are supplementary specified clauses setting forth conditions or requirements peculiar to the Work taking precedence over the General Provisions.

Specifications: The directions, provisions, and requirements contained or referred to in the Contract Documents, together with all duly authorized written agreements and directives made or to be made pertaining to the manner of performing the Work, or to the quantities and qualities of materials to be furnished or the quantities and qualities of work to be performed under the Contract.

State: State of New Jersey.

Subcontractor: Any individual, partnership, firm or corporation who undertakes for the Contractor, with the prior approval of the Project Manager, the partial or total manufacture or installation, or both, of one or more items of work under the terms of the Contract, or who performs other services for the Contractor as required to fulfill the terms of this Contract, by virtue of an agreement with the Contractor.

Substantial Completion: The point at which the Project Manager determines that the performance of work or portion thereof under the Contract, except Remaining Work, has been completed: provided that the Project Manager has determined, in the Project Manager's sole discretion, that (1) the project is safe and convenient for use and occupancy by the public and NJ TRANSIT employees and visitors; and (2) the project and facilities resulting therefrom may be used for the purposes for which they were intended.

Substitution: A product which, in the opinion of the Engineer, does not comply in form, fit, functionality, maintainability, useful life and quality of performance, with the technical specification requirements yet is proposed by the Contractor for incorporation into the Work in lieu of a specified product.

Superintendent: The Contractor's designated representative at the Construction Site responsible for the supervision and coordination of the Work.

Supplier: Any individual, partnership, firm or corporation which provides materials or equipment but not labor or services to the Contractor in partial fulfillment of the Scope of the Work of the Contract and who is responsible to the Contractor by virtue of an agreement.

Surety: The corporate body authorized to issue surety bonds in New Jersey which is bound with and for the Contractor for the guarantee of its proposal and the satisfactory performance of the Work by the

Contractor, and the prompt payment in full for materials, labor, equipment, rentals, utility services, and debts and obligations, as provided in the bonds.

Total Bid: The total monetary amount of the Bidder's proposal in dollars for performance of the Work of the entire Contract.

Technical Data: Written, typed or printed material prepared by the Contractor, Subcontractors, vendors and suppliers or others, whether or not copyrighted, and submitted by the Contractor in response to the requirements set forth in these specifications. Technical data include, but are not limited to, product data, shop drawings, pictorial representations, reports, schedules, studies, and assessments.

Technical Provisions: The Technical Provisions are specific requirements setting forth the materials and methods required to accomplish the Work.

U.S. Department of Transportation: The Secretary of the U.S. Department of Transportation, and other persons who may at the time be acting in the capacity of the Secretary, or an authorized representative or other persons otherwise authorized to perform the functions to be performed by USDOT, including representatives of the Federal Transit Administration (FTA).

Work: Work shall mean the furnishing of labor, materials, equipment, and other incidentals necessary or convenient to the successful completion of the Project and the carrying out of the duties and obligations imposed by the Contract, including alterations, amendments or extensions.

## 1.2 ORDER OF PRECEDENCE

The sequence of precedence pertaining to the Contract Documents is as follows:

Contract Change Orders and Directive Letters

Addenda, if any

Special Provisions, if any

General Provisions

Technical Provisions

Details

Figured Dimensions

Scaled Dimensions

Drawings

Referenced Standards

## 1.3 REFERENCED STANDARDS

- 1.3.1 All materials, equipment and workmanship, specified by the number, symbol or title of a referenced standard shall comply with the latest edition or revision thereof and all amendments and supplements thereto in effect on the date of the opening Bids, except where a particular issue is indicated in the reference. Where products or workmanship are specified by an association, trade or federal standard, Contractor shall comply with the requirements of that standard, except where exceeded by the requirements of the Contract plans and specifications or regulatory authorities. Where referenced

standards are in conflict, the more stringent shall apply. In case of conflicting requirements between Referenced Standards and the Contract Documents, the Contract Documents shall govern.

1.3.2 Where the New Jersey Uniform Construction Code, its adopted subcodes and their referenced standards, and the other regulations described in Article 1.6 are silent regarding the construction requirements of the work specified herein, installation shall be in accordance with the most current versions of the following:

- 1.) National Fire Protection Association (NFPA) Standard 130 - Standard for Fixed Guideway Transit Systems;
- 2.) American Railway Engineering and Maintenance Association (AREMA) Manual of Railway Engineering;
- 3.) Industrial Risk Insurers (IRI) Standards;
- 4.) NJ TRANSIT Standards as identified in the Contract Documents;
- 5.) NJ TRANSIT Graphic Standards Manual; and
- 6.) NJDOT Standard Specification for Road Bridge Construction (except Section 100).

#### 1.4 INTENTION

1.4.1 The Contract Documents are intended to provide for and comprise everything necessary to the proper and complete finishing of the work in every part notwithstanding that each and every item necessary may not be shown on drawings or mentioned in the specifications. The Contractor shall abide by and comply with the true intent and meaning of all the Contract Documents taken as a whole, and shall not avail itself of any apparent error or omission, should any exist.

1.4.2 The Contractor's execution of this Contract constitutes its certification that it satisfied itself, through personal inspection, as to the correctness of information given which may affect the quantity, size and quality of materials required for a satisfactorily completed Contract, whether or not such information is indicated on the Drawings or within the Specifications. The Contractor confirms that it checked and verified conditions outside of the Contract Limit Lines to determine whether or not any conflict exists between elevations or other data shown on the drawings and existing elevations or other data outside of the Contract Limit Lines.

1.4.3 Work that may be called for in the Specifications and not shown on the Drawings or shown on the Drawings and not called for in the Specifications, shall be executed and furnished by the Contractor as if described in both. Should work or materials be required which are necessary for the proper carrying out of the intent thereof, the Contractor shall understand same to be implied and required and it shall perform such work and furnish such materials as fully as if they were particularly delineated or described.

1.4.4 The Contractor shall not at any time after the execution of this Contract set up any claims whatsoever based upon insufficient data, patent ambiguities, inconsistencies or confusion in the Contract Documents or incorrectly assumed conditions, nor shall it claim any misunderstanding with regard to the nature,

conditions or character of the work to be done under the Contract, except as provided for under Article 8.4- DIFFERING, LATENT OR UNUSUAL SITE CONDITIONS.

1.4.5 Should any error or discrepancy appear or should any doubt exist or any dispute arise as to the true intent and meaning of the Contract Documents, or should any portion of same be obscure or capable of more than one method of construction, the Contractor shall immediately apply in writing to the Construction Manager for the correction or explanation thereof and, in case of dispute, the Contracting Officer's decision shall be final.

1.4.6 Each and every provision of law and clause required by law to be inserted in this Contract shall be deemed to be inserted herein and the Contract shall be read and enforced as though it were included herein, and if through mistake or otherwise such provision is not inserted, or is not correctly inserted, then upon the application of either party the Contract shall forthwith be physically amended to make such insertion or correction.

1.4.7 NJ TRANSIT may act directly through its own employees or may act indirectly through retained independent third party Contractors and consultants and their employees. The Contractor shall be advised by the Contracting Officer of those persons authorized to act on NJ TRANSIT's behalf.

1.4.8 A waiver on the part of NJ TRANSIT of any breach of any part of the Contract shall not be held to be a waiver of any other or subsequent breach.

## 1.5 INTERPRETATION

1.5.1 The headings of the articles herein are for convenience of reference only and shall have no bearing on their interpretation. Whenever in these Contract Documents the following terms are used, the intent and meaning shall be interpreted as defined herein. All of the terms used herein are treated throughout the Contract as if each were the singular number and non-specific gender.

1.5.2 Wherever in the Contract Documents the words "directed", "required", "ordered", "designated", "prescribed", or words of like import are used, it shall be understood that the "direction", "requirement", "order", "designation", or "prescription" of NJ TRANSIT is intended and similarly the words "approved", "acceptable", "satisfactory", or words of like import, shall mean "approved by", or "acceptable to", or "satisfactory to" NJ TRANSIT unless otherwise expressly stated. Where "as shown", "as indicated", "as detailed", or words of similar import are used, it shall be understood that the reference is made to the Specifications and Drawings accompanying the Contract unless stated otherwise.

1.5.3 References to all Articles or Sections include all Sub-articles or subsections under the Article referenced, and references to all Sub-articles include all sub-Sub-articles.

1.6 PERMITS, LAWS, AND REGULATIONS

1.6.1 NJ TRANSIT in entering into this Contract does not waive its sovereign immunity except as provided in the New Jersey Contractual Liability Act, N.J.S.A. 59:13-1 et seq. The terms and conditions of the Contract are not intended to, and shall not be deemed to expand the waiver of sovereign immunity as set forth in that Act.

1.6.2 The work under this Contract is subject to Federal, State, and local laws, ordinances, codes, and regulations, including those of railroad companies and utility companies, for work on the Project. Except as otherwise provided in the Contract Documents, the Contractor shall obtain and pay for necessary permits and make necessary arrangements with the authorities having jurisdiction. Where the Contractor's compliance with Federal, State or local laws, ordinances, codes or regulations may or will conflict with the Contract, the Contractor shall notify the Construction Manager in writing for appropriate action.

1.6.3 NJ TRANSIT will supply the Contractor with applications for construction permits, as required by the New Jersey Department of Community Affairs (DCA). The Contractor shall return within seven (7) calendar days permit applications signed and sealed to NJ TRANSIT. NJ TRANSIT will submit the Contractor's applications along with all fees required, to the DCA. The fees for all DCA applications shall be the responsibility of NJ TRANSIT.

- (a) Except as otherwise provided in the Contract Documents, all work shall be performed in accordance with the New Jersey Uniform Construction Code (NJUCC), N.J.A.C. 5:23-1 et seq., its adopted subcodes, and their referenced standards. Specific requirements of the NJUCC and its adopted subcodes shall supersede any conflicting requirements in other documents referenced herein.
- (b) The Contractor shall be responsible for assisting NJ TRANSIT in the preparation and submission of any new or revised plans and specifications required due to DCA requests for clarification, changes in scope of work, etc., necessary for obtaining amended or additional permits or approvals for work for which NJ TRANSIT has already secured construction permits.
- (c) The Contractor shall be responsible for requesting utility location markups and obtaining permits and approvals from utility authorities and other authorities having jurisdiction.

1.6.4 It shall be the responsibility of the Contractor to keep itself fully informed concerning all requirements of law, including but not limited to, all Federal, State, and local laws, ordinances, codes, and regulations which in any manner affect the Project, and of all such orders and decrees of bodies or tribunals having jurisdiction or authority over the same. The Contractor shall at all times observe, and shall cause its subcontractors, agents, and employees to observe, such requirements of law, and shall defend, indemnify, save, and hold harmless the State of New Jersey and NJ TRANSIT and all of their officers, agents, and employees against claims and liabilities arising from or based upon the violation of such requirement of law whether by the Contractor or its agents, Subcontractors or employees.

- 1.6.5 Plumbing, drainage, and sewage disposal work shall conform with applicable Federal, State and all relevant utility regulator environmental laws and regulations.
- 1.6.6 Electrical and applicable mechanical materials and systems shall bear the label of the Underwriters' Laboratories (UL) and shall be listed in the publication issued by the UL. Other materials or systems bearing labels of other testing laboratories may be accepted upon written approval of the Engineer. Rules of the National Fire Protection Association shall be followed explicitly unless deviations are agreed to in writing by the Engineer or otherwise modified by these specifications.
- 1.6.7 Work shall be conducted in accordance with the State of New Jersey Department of Labor and Industry Construction Safety Code, as promulgated by the Commissioner of Labor and Industry under the authority of the Construction Safety Act, N.J.S.A. 34:5-166 to 34:5-181, and applicable provisions of the Occupational Safety and Health Administration (OSHA), 29 C.F.R. 1910, Rules and Regulations. Where the Construction Safety Code refers to the designation of General Contractor for enforcing compliance with the Code, such designation shall be intended to refer to the Contractor.
- 1.6.8 Construction work shall be performed in accordance with the requirements of the New Jersey Uniform Fire Code (NJUFC), N.J.A.C. 5:71-1 et seq.
- 1.6.9 The Contractor shall immediately notify the Construction Manager should any review or inspection by any regulatory agency or official result in the issuance of a citation or notice of violation of any permit, regulation, statute or other governmental rule.

#### 1.7 FEDERAL, STATE, AND LOCAL TAXES

Except as may be otherwise provided in the Contract, each Contract Item shall include all applicable taxes and duties. N.J.S.A. 54:32B-9 provides that any sale or service to NJ TRANSIT is not subject to the sales and use taxes imposed under the Sales and Use Tax Act. N.J.S.A. 54:32B-8.22 provides that sales made to Contractors or repairmen of materials, supplies or services for exclusive use in erecting structures, or building on, or otherwise improving, altering or repairing real property of NJ TRANSIT are exempt from the tax on retail sales imposed by the Sales and Use Tax Act. The exemption provided under N.J.S.A. 54:32B-8.22 is conditioned on the person seeking such exemption qualifying therefore pursuant to the rules and regulations and upon the forms prescribed by the New Jersey Division of Taxation. The required form, "Contractor's Exemption Purchase Certificate" (Form No. ST-13), can be obtained by writing or calling the New Jersey Division of Taxation, Tax Information Service (TIS), West State and Willow Streets, Trenton, New Jersey 08625.

NJ TRANSIT is exempt from Federal Excise Taxes. The State of New Jersey's Federal Excise Tax exemption number is 22-75-0050K.



The Contractor and any Subcontractor providing goods or performing services under the Contract, and each of their Affiliates, shall, during the term of the Contract, collect and remit to the Director of the Division of Taxation in the Department of the Treasury the use tax due pursuant to the "Sales and Use Tax Act", P.L. 1966, c. 30 (N.J.S.A. 54:32B-1 et seq.) on all their sales of tangible personal property delivered into the State.

#### 1.8 INDEPENDENT CONTRACTOR

The relationship of the Contractor to NJ TRANSIT is that of an independent Contractor, and said Contractor, in accordance with its status as an independent Contractor, covenants and agrees that it will conduct itself consistent with such status, that it will neither conduct itself as nor claim to be an officer or employee of NJ TRANSIT or the State by reason thereof. The Contractor will not, by reason thereof, make any claim, demand or application to or for any right or privilege applicable to an officer or employee of NJ TRANSIT or the State, including, but not limited to, worker's compensation coverage, unemployment insurance benefits, social security coverage or retirement membership or credit.

#### 1.9 ASSIGNING AND SUBCONTRACTING CONTRACT

1.9.1 The Contractor shall not transfer, assign or otherwise dispose of the Contract or Contract funds, due or to become due, or claims of any nature it has against NJ TRANSIT to any other party except upon the express written approval of NJ TRANSIT, which approval NJ TRANSIT shall not unreasonably withhold. Application for subcontracting any part or parts of the work shall be made by the Contractor and shall be addressed to NJ TRANSIT through the Construction Manager. The Contractor shall perform with its own organization and with the assistance of workmen under its immediate superintendence, work amounting to not less than twenty (20) percent of the Contract Price, exclusive of Bid Items for Insurance, Performance/Payment Bonds, Mobilization and Allowances.

1.9.2 At the Preconstruction Meeting, the Contractor shall submit to the Construction Manager a list of, and Subcontractor Evaluation Data Forms (Appendix A) for, all Subcontractors to be used on the Project within the first two months. The list shall identify the Subcontractor's name, nature of work and value of work to be performed, and date work is to start. Thereafter, the Contractor shall provide the Construction Manager with at least fifteen (15) calendar days' notice before engaging additional or alternative Subcontractors. Each proposed Subcontractor shall submit a completed Subcontractor Evaluation Data Form. NJ TRANSIT reserves the right to reject any Subcontractor with unsatisfactory qualifications, experience or record of performance. No Contract shall be entered into by the Contractor with a Subcontractor before its name has been approved in writing by the Construction Manager.

All Subcontractors are required to comply with the Public Works Contractor Registration Act N.J.S.A. 34:11-56.48 et seq. as amended. Subcontractors shall not engage in the performance of any public work as defined in N.J.S.A. 34:11-56.26 unless the Subcontractor is registered pursuant to the Act. As part of the

post award Subcontractor approval process detailed above, certificates of registration shall be submitted to NJ TRANSIT's Construction Manager for each Subcontractor.

In accordance with N.J.S.A. 52:32-44 all Subcontractors must obtain a Business Registration Certificate prior to performing work or providing goods and/or services on the contract. A Subcontractor shall provide a copy of its business registration to the Contractor who shall forward it to NJ TRANSIT. No contract with a Subcontractor shall be entered into by the Contractor unless the Subcontractor first provides proof of valid business registration.

The Contractor shall maintain a list of the names of all Subcontractors and their current addresses, updated as necessary during the course of the Contract performance. In conjunction with the Subcontractor approval process detailed above, the Contractor shall submit a complete and accurate list of the Subcontractors to NJ TRANSIT before for final payment is made.

- 1.9.3 The Contractor agrees that it is as fully responsible to NJ TRANSIT for the acts and omissions of its Subcontractors and of persons either directly or indirectly employed by them as it is for the acts and omissions of persons directly employed by the Contractor. The Contractor hereby gives its assurance that, when minimum wage rates are specified, they shall apply to labor performed on all work subcontracted, assigned or otherwise disposed of in any way.
- 1.9.4 The Contractor agrees to bind every Subcontractor to and have every Subcontractor agree to be bound by the terms of the Contract Documents, as far as applicable to its work. Each Subcontractor Evaluation Data Form shall contain the Subcontractor's certification that it has reviewed and is familiar with the Contract Documents in their entirety and that the Subcontractor shall comply with all Contract requirements.
- 1.9.5 It is understood, however, that any consent of NJ TRANSIT for the subcontracting of any of the work of the Contract in no way relieves the Contractor from its full obligations under the Contract. Approval by NJ TRANSIT of a Subcontractor, including a material supplier, does not relieve the Contractor or its Subcontractor of the responsibility of complying with the Contract Documents. Further, the approval of a Subcontractor does not imply approval of any material, installed equipment, substitution or additional approved equal.
- 1.9.6 When the Contractor proposes to subcontract a portion of an item which involves a breakdown of the unit of measurement of that item, it shall submit a breakdown of cost showing the value of the portion of the item to be subcontracted in relation to the value of the whole item, which shall be subject to the approval of NJ TRANSIT.
- 1.9.7 Nothing contained in the Contract Documents shall create any contractual relation between any Subcontractor and NJ TRANSIT. The consent to subcontract any part of the work shall not be construed to

be an approval of the said subcontract or of any of its terms, but shall operate only as an approval of the Contractor's request for the making of a subcontract between the Contractor and its chosen Subcontractor.

#### 1.10 CONTRACTING OFFICER'S AUTHORITY

The Contracting Officer is the final interpreter of the terms and conditions of the Contract and the judge of its performance. The Contracting Officer has the sole authority to execute the Contract; order additions, deductions and changes to the Work; render final decisions on disputes; suspend or terminate the Work, or portions thereof; and accept or reject Contractor performance.

#### 1.11 PROJECT MANAGER'S AUTHORITY

In connection with the Work to be performed under the Contract, the Project Manager shall be the technical representative of the Contracting Officer. The Project Manager shall review and approve the Contractor's invoices, after certification by the Construction Manager, and the Project Manager shall authorize payments. When duly authorized in writing by the Contracting Officer, the Project Manager shall have the authority to give approval of and order changes in the Work. The limits of this authorization shall be specified in writing by the Contracting Officer and provided to the Contractor. The Project Manager shall monitor the performance of the Contract, shall determine Substantial Completion of the Work and recommend to the Contracting Officer its Final Acceptance.

#### 1.12 CONSTRUCTION MANAGER'S AUTHORITY

The Construction Manager shall apply the Contract Documents, and shall judge the quantity, quality, fitness and acceptability of all parts of the work. In addition, the Construction Manager shall determine whether specific items of construction work, methods or materials are properly specified in the Contract Documents. In the event of a dispute, the Contractor shall proceed diligently with the performance of the work in accordance with the Construction Manager's determination, pending the decision of the Contracting Officer. The Construction Manager shall certify Contractor's invoices for work performed and materials delivered to the site, and shall be given access to the work for inspection at all times. The Construction Manager shall not have authority to give approval of nor order changes in work which alter the terms or conditions of the Contract, nor which involve additional cost or Contract Time unless duly authorized in writing by the Contracting Officer. The Construction Manager may, however, make recommendations to the Contracting Officer for such changes, whether or not costs are to be revised and the Contracting Officer may act, at the Contracting Officer's discretion, on the basis of the Construction Manager's recommendations. The Construction Manager has the authority to reject unsuitable material or suspend work that is being improperly performed.

#### 1.13 INSPECTOR'S AUTHORITY

Inspectors are authorized to inspect work done and materials furnished. Such inspection may extend to all or any part of the work and to the preparation, fabrication or manufacture of the materials to be used. Inspectors are not authorized to alter or waive the provisions of the Contract. Inspectors are not authorized

to issue instructions contrary to the Contract Documents, or to act as foremen for the Contractor; however, they shall have the authority to reject work or materials until a question at issue can be referred to and decided by the Construction Manager.

1.14 NOTICE AND COMMUNICATION

1.14.1 Written notice shall be deemed to have been duly served and received by NJ TRANSIT and the Contractor if: **(A)** Delivered in person to the intended individual, to a member of the firm, an officer of the corporation or their authorized representative on the Work, or **(B)** Sent by certified mail, or other mail or courier service, with delivery receipt, to the last business address known to the individual who gives the notice, or **(C)** Sent by telefacsimile or electronic mail, followed by a hard copy to the last business address known to the individual who gives the notice.

1.14.2 Communications to the Contractor shall be transmitted through and coordinated by the Contractor's authorized representative(s), as designated at the Pre-Construction Conference.

1.14.3 Communications to NJ TRANSIT shall be transmitted through and coordinated by the Construction Manager. Correspondence shall be addressed to the appropriate NJ TRANSIT authorized representative as set forth in the Contract Documents or as otherwise designated by NJ TRANSIT at the Pre-Construction Conference. Upon written notice to the Contractor, NJ TRANSIT may change its authorized designee(s) at any time.

1.14.4 All communications to NJ TRANSIT shall be clearly marked with NJ TRANSIT's Contract Number and Contract Title

1.15 DISPUTES

Disputes regarding whether a party has failed to make payments may be submitted to a process of alternative dispute resolution. Disputes arising in the performance of this Contract, which are not resolved by agreement of the parties shall be decided in writing by the authorized representative of the Contracting Officer. This decision shall be final and conclusive unless within ten (10) calendar days from the date of receipt of its copy, the Contractor mails or otherwise furnishes a written appeal to the Contracting Officer. In connection with any such appeal, the Contractor shall be afforded an opportunity to be heard and to offer evidence in support of its position. Pending final decision of a dispute hereunder, the Contractor shall proceed diligently with performance of the Contract in accordance with the decision of the authorized representative of the Contracting Officer.

1.16 GOVERNING LAW; CONSENT TO JURISDICTION AND WAIVER OF TRIAL BY JURY

1.16.1 This Contract shall be construed in accordance with and shall be governed by the Constitution and laws of the State of New Jersey.

1.16.2 Except as otherwise provided in this Contract, disputes and claims arising under this Contract which are not disposed of by mutual agreement shall be governed by the laws of the State of New Jersey as they may from time to time be in effect. The Contractor, by entering into this Contract, consents and submits to the exclusive jurisdiction of the Courts of the State of New Jersey over any action at law, suit in equity or other proceeding that may arise out of this Contract, and the Contractor agrees, during the period of performance and of Warranty, to maintain within the State of New Jersey an agent to accept service of legal process on its behalf. Notwithstanding the language of N.J.S.A. 59:13-4, the Contractor expressly waives trial by jury on any and all disputes and claims arising out of this Contract whether by or against the Contractor, NJ TRANSIT or any other person or entity.

1.17 AUDIT AND INSPECTION OF RECORDS

The Contractor shall retain all Contract records and permit the authorized representatives of NJ TRANSIT, the State of New Jersey, the USDOT , the FTA and the Comptroller General of the United States and their duly authorized representatives, such as Project Management Oversight (PMO, Integrity Oversight Monitors (IOM) etc. to inspect and audit all financial data, operational data and other records of the Contractor including but not limited to disclosure forms, payment requests, change orders, invoices, certified payrolls, manifests, etc. relating to products, transactions or services provided under this Contract including the performance of its Subcontractors from the date of the Advertisement of the Invitation for Bid (IFB) and for five (5) years after final payment under this Contract has been made.

NJ TRANSIT, the State of New Jersey, the USDOT, the FTA and the Comptroller General of the United States and their duly authorized representatives also shall have the right to examine all aspects of the products, transactions and services and specifically the right to conduct interviews, on-site visits, surveillance, field activities and head counts and to perform financial audits and operational reviews as deemed necessary to prevent, remediate or mitigate fraud, waste and abuse. Any inspection, audit or review or lack thereof shall not relieve the Contractor of responsibility for satisfactory performance of the Work. Contractor shall maintain a true and correct set of records for all financial and operational data in sufficient detail to permit reasonable verification or correction of charges and performance in accordance with this Contract from the date of the Advertisement of the IFB and for five (5) years after final payment under this Contract has been made.

The Contractor further agrees to include in all its subcontracts hereunder a provision requiring the Subcontractor to keep all Contract records and that NJ TRANSIT, the Department of Transportation, the FTA and the Comptroller General of the United States or any of their duly authorized representatives , such as PMO,IOM etc. shall, until the expiration of five (5) years after final payment under the subcontract, have access to and the right to examine pertinent books, documents, papers, and records of such subcontractor, involving transactions related to the Subcontractor. The term "Subcontractor" as used in this clause excludes (1) purchase orders not exceeding \$10,000 and (2) subcontracts or purchase orders for public utility services at rates established for uniform applicability to the general public.

Pursuant to N.J.S.A. 52:15C-14(d), the Contractor shall maintain all documentation related to products, transactions or services under this contract for a period of five (5) years from the date of final payment. Such records shall be made available to the New Jersey Office of State Comptroller upon request.

The periods of access and examination described above, for records which relate to (1) appeals under the "Disputes" clause of the Contract, (2) litigation or the settlement of claims arising out of the performance of this Contract, or (3) costs and expenses of this Contract as to which exception has been taken by the Comptroller General, USDOT, FTA, NJ TRANSIT or the State of New Jersey or their duly authorized representatives, shall continue until such appeals, litigation, claims, or exceptions have been disposed of.

## **2. CONTRACT TIME, SUSPENSION AND TERMINATION**

### **2.1 TIME OF COMPLETION - DELAY - LIQUIDATED DAMAGES**

2.1.1 The Contractor and NJ TRANSIT recognize that delay in completion of the project will result in damage to the State of New Jersey in terms of the effect of the delay in the use of the Project upon the public convenience and economic development of the State of New Jersey, and will also result in additional cost to NJ TRANSIT for engineering, inspection, and administration of the Contract. Because some of this damage is difficult or impossible to estimate, the parties agree that if the Contractor fails to substantially complete the project or any interim milestones within the time stated in the Contract, or within such further time as may have been granted in accordance with the provisions of the Contract, or fails to complete Remaining Work, other than Punch List Work (as described in Article 13.2- SUBSTANTIAL COMPLETION) within the period fixed by NJ TRANSIT, the Contractor shall pay NJ TRANSIT liquidated damages, in accordance with the amount set forth in the Special Provisions for each day that it is in default on time to complete the work. The days in default shall be the number of calendar days in default when the time for completion of the Project is specified on the basis of calendar days or a fixed date; and shall be the number of working days in default when the time for completion is specified on the basis of working days. NJ TRANSIT shall recover said damages by deducting the amount thereof from monies due or that may become due the Contractor, and if said monies be insufficient to cover said damages, then the Contractor or its Surety shall pay the amount due. This clause is expressly limited in purpose and effect to damages to NJ TRANSIT and the State of New Jersey as a consequence of the Contractor's failure to complete the project on time. It is not intended, and shall not be construed, to apply to any other claim for damages or disputes arising from the Contractor's performance on the Project, nor shall it limit the Contractor's duty to indemnify NJ TRANSIT for claims made by third parties.

2.1.2 The work embraced in this Contract including work authorized under Article 3.1 shall commence as soon as possible but not later than ten (10) calendar days after receipt of a Notice to Proceed unless otherwise specified by NJ TRANSIT.

The Contractor agrees that said work shall be prosecuted regularly, diligently, and without interruption at such rate of progress as will insure substantial completion thereof within the time specified. It is expressly understood and agreed, by and between the Contractor and NJ TRANSIT, that the time for the completion

of the work herein is a reasonable time for the completion of the same. It is further agreed that float, or slack time, is not for the exclusive use or benefit of either the Contractor or NJ TRANSIT, as further described in Article 6.2- Construction Project Schedule.

2.1.3 It is further agreed that time is of the essence of each and every portion of this Contract and of the Specifications wherein a definite and certain length of time is fixed for the performance of any act whatsoever, and where under the Contract additional time is allowed for the completion of any work, the new time limit fixed by such extension shall be of the essence of this Contract. The Contractor shall not be charged with liquidated damages when the delay in the completion of the work arises from both: a.) causes beyond the reasonable control and without any fault or negligence of the Contractor, its officers, employees, agents, servants, Subcontractors, and suppliers, including but not restricted to, acts of God, or of the public enemy, acts of another contractor in the performance of a Contract with NJ TRANSIT, fires, floods, epidemics, quarantine restrictions, labor disputes not determined by final judicial or administrative adjudication to have been caused or provoked by the illegal acts of the Contractor or one of its Subcontractors or agents, freight embargoes, and unusually severe weather and, b.) such causes arise after the award of the Contract and neither were nor could have been anticipated by the Contractor by reasonable investigation before such award. The basis to define unusually severe weather will be the data showing high and low temperatures, precipitation and wind conditions in the geographic area of the Work for the previous twenty (20) years, as compiled by the recording station of the U.S. National Weather Service located nearest to the Work.

2.1.4 Even though a cause of delay meets both conditions a.) and b.) above, an extension shall be granted only to the extent that (i) the completion of the affected work is actually and necessarily delayed, (ii) the effect of such cause could not be anticipated and avoided or mitigated by the exercise of all reasonable precautions, efforts and measures (including planning, scheduling and rescheduling) whether before or after the occurrence of the cause of delay, and (iii) the critical path of the project schedule is actually extended due to the delay beyond the required Contract completion date. Any reference in this Article to the Contractor shall be deemed to include materialmen, suppliers, and Subcontractors, whether or not in privity of Contract with the Contractor, all of whom shall be considered as agents of the Contractor for the purposes of this Article. A delay resulting from a cause meeting all conditions in Sub-article 2.1.3 and this Sub-article 2.1.4 shall be deemed an Excusable Delay.

2.1.5 The period of any extension of time shall be only that which is necessary to make up the time actually lost as determined by NJ TRANSIT. NJ TRANSIT may defer all or part of its decision on an extension and any extension may be rescinded or shortened if it subsequently is found that the delay can or could have been overcome or reduced by the exercise of reasonable precautions, efforts and measures.

2.1.6 In case the Contractor shall be actually and necessarily delayed by reason of the failure of NJ TRANSIT to deliver to the Contractor access to the Project Site or any materials or facilities to be furnished by NJ

TRANSIT which are actually needed for use in the work, or by any act or omission on the part of NJ TRANSIT, and such delay is recognized by NJ TRANSIT in writing, such delay shall also be deemed to be an Excusable Delay. The time for completion of the Project shall be extended by NJ TRANSIT by the amount of time of such delay as determined by NJ TRANSIT, but no allowance by way of damages of any kind or nature will be made for such failure.

- 2.1.7 As a condition precedent to the granting of an extension of time, the Contractor shall give written notice to NJ TRANSIT within seven (7) calendar days after the time when the Contractor knows or should know of any cause which might under reasonably foreseeable circumstances result in delay for which it may claim an extension of time (including those causes for which NJ TRANSIT itself is responsible or of which NJ TRANSIT has knowledge), specifically stating in such notice that an extension is or may be claimed, identifying such cause and describing, as fully as practicable at that time, the nature and expected duration of the delay, including justification, and its effect on the completion of that part of the work identified in the notice. Since the possible necessity for an extension of time may materially alter the scheduling plans, and other actions of NJ TRANSIT and since, with sufficient notice, NJ TRANSIT may, if it should so elect, attempt to mitigate the effect of the delay for which an extension of time might be claimed, and since mere oral notice may cause dispute as to the existence or substance thereof, the giving of written notice as above required shall be of the essence of the Contractor's obligations hereunder. Failure to give the written notice within the aforementioned seven (7) calendar day period shall deprive the Contractor of any right to an extension of time, except to the extent that NJ TRANSIT may determine otherwise in its sole discretion.

It shall in all cases be presumed that no extension, or further extension of time, is due unless the Contractor shall affirmatively demonstrate the extent thereof to the reasonable satisfaction of NJ TRANSIT. To this end, the Contractor shall maintain adequate records supporting any claim for an extension of time, and in the absence of such records, this presumption shall be deemed conclusive.

- 2.1.8 In regard to an injunction or interference of public authority which may delay or impact the Project, the Contractor shall give NJ TRANSIT a copy of the injunction or other orders and of the papers upon which the same shall have been granted.

- 2.1.9 Within a reasonable time after receipt of a written notice requesting an extension of time NJ TRANSIT will advise the Contractor if such notice is adequate, or if further information is required. Failure of NJ TRANSIT to furnish the Contractor with the foregoing advisement shall not, however, be deemed to waive NJ TRANSIT's right to deny an extension of time. Within a reasonable time after NJ TRANSIT, at its sole discretion, has determined that the Contractor has provided sufficient information for NJ TRANSIT to decide on a request for an extension of time, NJ TRANSIT shall issue a determination on that request. In the event that NJ TRANSIT was unable to decide on a request for an extension, NJ TRANSIT may issue at the completion of the Project, in conjunction with issuing its Final Certificate of Payment, a final determination on the Contractor's request or requests for an extension of time.



- 2.1.10 Only the actual delay or impact to the Contractor necessarily resulting from the causes above-mentioned, as determined by NJ TRANSIT, shall be considered for an extension of time. In case the Contractor shall be delayed or impacted at any time or for any period by two or more of the causes above-mentioned, the Contractor shall not be entitled to a separate extension for each one of the causes but only one period of extension shall be granted for the period of concurrent delay. In case the Contractor shall be actually and necessarily delayed by one or more of the causes above-mentioned in the performance of any portion of the Project, the extension of time to be granted to the Contractor shall be only for such portion of the Project. The Contractor shall not be entitled by reason of such delay to an extension of time for the completion of the remainder of the Project. If the Contractor shall be so delayed as to a portion of the Project, it shall nevertheless proceed continuously and diligently with the prosecution of the remainder of the Project. No demand by the Contractor that NJ TRANSIT determine any matter of extension of time for the completion of the Project or any part thereof will be of any effect whatsoever unless the same be made in writing and duly served upon NJ TRANSIT prior to the issuance of the Final Certificate of Payment as provided for in Article 12.8, FINAL PAYMENT.
- 2.1.11 Delay to or impacts upon the Contractor's performance arising out of any request of the Contractor to change the order of furnishing working drawings as provided elsewhere in this Contract or arising out of any changes made or requested by the Contractor in any matters shown or indicated on the Contract Drawings will not be cause for an extension of time, and all additional costs to the Contractor, incidental to such request or change, shall be borne by the Contractor.
- 2.1.12 The permitting of the Contractor to go on and finish the Project or any part thereof after the time fixed for completion or after the date to which the time for completion may have been extended or the making of payments to the Contractor after any such period shall not operate as a waiver on the part of NJ TRANSIT of any rights under this Contract, including but not limited to declaring the Contractor in default.
- 2.1.13 The determination of NJ TRANSIT as to any matter of extension of time for completion of the Project or any part thereof shall be binding and conclusive upon the Contractor.
- 2.2 NO DAMAGES FOR DELAY
- 2.2.1 The Contractor expressly waives the right to make any claim against NJ TRANSIT for damages or additional compensation for any delay to or impact upon the performance of this Contract occasioned by any act or omission to act by NJ TRANSIT or its employees or any third parties for any reason whether or not enumerated in Article 2.1, and agrees that any such claim shall be fully compensated for by an extension of time to complete performance of the work as provided in Article 2.1.
- 2.2.2 Except as provided in Subarticle 2.2.4, the Contractor alone hereby specifically assumes the risk of all delays, obstruction, or interference of any kind, duration or cause whatsoever, whether or not within the contemplation of the parties or foreseeable.

2.2.3 The Contractor shall have no right to rescind or terminate this Contract, and Contractor shall have no cause of action under any theory of unjust enrichment, quasi-contract, quantum meruit or additional risk by reason of any delay, obstruction, or interference of any kind or duration whatsoever.

2.2.4 Nothing in these General Provisions is intended to limit Contractor's remedy for delayed performance caused by NJ TRANSIT's negligence, bad faith, active interference or other tortious conduct, to the extent such limitation is determined by a court of law to be void and unenforceable under N.J.S.A. 2A:58B-3.

## 2.3 SUSPENSION OF WORK

2.3.1 If the Contracting Officer deems it advisable, the Contracting Officer may notify the Contractor in writing to suspend work on one or more occasions on all or any part of the Project, for a period not to exceed ninety (90) calendar days in the aggregate. After notification(s) is delivered to the Contractor, the Contractor shall do no work where so suspended until it has received written notice from the Contracting Officer to resume work.

2.3.2 When work is suspended as provided above, payments for the completed parts of the work will be made as provided and a suitable extension of time for completing the suspended work will be granted where appropriate. Should any single suspension be for a period greater than forty-five (45) calendar days and the Contractor incurs unavoidable extended field overhead costs as a result of the suspension, the Contractor shall notify the Contracting Officer within thirty (30) calendar days of the completion of the suspension period and provide a detailed accounting of such extended field overhead costs. No profit markup will be allowed on extended field overhead costs. The Contracting Officer's determination as to the amount of compensation to be paid under this clause shall be final and conclusive. Under no circumstances shall any other compensation or allowance be made on account of such suspension. No payment will be made for work done by the Contractor on suspended work.

2.3.3 Within the period of ninety (90) calendar days (or the lesser period specified) after a notice of suspension is delivered to the Contractor, or within any extension of that period to which the parties shall have agreed, NJ TRANSIT shall either: a.) cancel the notice of suspension, or b.) terminate the work covered by such suspension as provided in Article 2.4, TERMINATION FOR CONVENIENCE, or c.) negotiate reasonable compensation with the Contractor for a further period of suspension.

## 2.4 TERMINATION FOR CONVENIENCE

2.4.1 NJ TRANSIT may terminate performance of work under this Contract in whole or, from time to time, in part if the Contracting Officer determines that a termination is in NJ TRANSIT's interest. The Contracting Officer shall terminate the work by delivering to the Contractor a Notice of Termination specifying the extent of termination and the effective date.

2.4.2 After receipt of a Notice of Termination, and except as directed by the Contracting Officer, the Contractor shall immediately proceed with the following obligations, regardless of any delay in determining or adjusting any amounts due under this clause:

- (a) Stop work as specified in the notice.
- (b) Place no further subcontracts or orders (referred to as subcontracts in this clause) for materials, services, or facilities, except as necessary to complete the continued portion of the Contract.
- (c) Terminate all subcontracts to the extent they relate to the work terminated.
- (d) Assign to NJ TRANSIT, as and if directed by the Contracting Officer, all right, title, and interest of the Contractor under the subcontracts terminated, in which case NJ TRANSIT shall have the right to settle or to pay any termination settlement proposal arising out of those terminations.
- (e) With approval or ratification to the extent required by the Contracting Officer, settle all outstanding liabilities and termination settlement proposals arising from the termination of subcontracts; the approval or ratification will be final for purposes of this clause.
- (f) As directed by the Contracting Officer, transfer title and deliver to NJ TRANSIT: (i) the fabricated or unfabricated parts, work in process, completed work, supplies, and other material produced or acquired for the work terminated, and (ii) the completed or partially completed plans, drawings, information, and other property that, if the Contract had been completed, would be required to be furnished to NJ TRANSIT.
- (g) Complete performance of the work not terminated.
- (h) Take any action that may be necessary, or that the Contracting Officer may direct, for the protection and preservation of the property related to this Contract that is in the possession of the Contractor and in which NJ TRANSIT has or may acquire an interest.
- (i) Use its best efforts to sell, as directed or authorized by the Contracting Officer, any property of the types referred to in Subparagraph (f) above; provided, however, that the Contractor (i) is not required to extend credit to any purchaser and (ii) may acquire the property under the conditions prescribed by, and at prices approved by the Contracting Officer. The proceeds of any transfer or disposition will be applied to reduce any payments to be made by NJ TRANSIT under this contract, credited to the price or cost of the work, or paid in any other manner directed by the Contracting Officer.

2.4.3 After expiration of the plant clearance period as defined in Subpart 45.6 of the Federal Acquisition Regulation, the Contractor may submit to the Contracting Officer a list, certified as to quantity and quality, of termination inventory not previously disposed of, excluding items authorized for disposition by the Contracting Officer. The Contractor may request NJ TRANSIT to remove those items or enter into an agreement for their storage. Within twenty (20) calendar days, NJ TRANSIT will accept title to those items and remove them or enter into a storage agreement. The Contracting Officer may verify the list upon removal of the items, or if stored, within sixty (60) calendar days from submission of the list, and shall correct the list, as necessary, before final settlement.

2.4.4 After termination, the Contractor shall submit a final termination settlement proposal to the Contracting Officer in the form and with the certification prescribed by the Contracting Officer. The Contractor shall submit the proposal promptly, but no later than one (1) year from the effective date of termination, unless extended in writing by the Contracting Officer upon written request of the Contractor within this one (1)-year period. However, if the Contracting Officer determines that the facts justify it, a termination settlement proposal may be received and acted on after one (1) year or any extension. If the Contractor fails to submit the proposal within the time allowed, the Contracting Officer may determine, on the basis of information available, the amount, if any, due the Contractor because of the termination and shall pay the amount determined.

2.4.5 Subject to Sub-article 2.4.4 above, the Contractor and the Contracting Officer may agree upon the whole or any part of the amount to be paid because of the termination. However, the agreed amount, whether under this Sub-article or Sub-article 2.4.6 below, exclusive of costs shown in Sub-article 2.4.6(b) below, may not exceed the total contract price as reduced by: (i) the amount of payments previously made and, (ii) the contract price of work not terminated. The Contract shall be amended, and the Contractor paid the agreed amount. Sub-article 2.4.6 below shall not limit, restrict, or affect the amount that may be agreed upon to be paid under this Paragraph.

2.4.6 If the Contractor and Contracting Officer fail to agree on the whole amount to be paid the Contractor because of the termination of work, the Contracting Officer shall pay the Contractor the amounts determined as follows, but without duplication of any amounts agreed upon under Sub-article 2.4.5 above:

- (a) For contract work performed before the effective date of termination, the total (without duplication of any items) of:
  - (i) The cost of this work;
  - (ii) The cost of settling and paying termination settlement proposals under terminated subcontracts that are properly chargeable to the terminated portion of the Contract if not included in subdivision (i) above; and
  - (iii) A sum, as profit on (i) above, determined by the Contracting Officer to be fair and reasonable; however, if it appears that the Contractor would have sustained a loss on the entire contract had it been completed, the Contracting Officer shall allow no profit under this subdivision (iii) and shall reduce the settlement to reflect the indicated rate of loss.
  
- (b) The reasonable costs of settlement of the work terminated, including:
  - (i) Accounting, legal, clerical, and other expenses reasonably necessary for the preparation of termination settlement proposals and supporting data;
  - (ii) The termination and settlement of subcontracts (excluding the amounts of such settlements); and

- (iii) Storage, transportation, and other costs incurred, reasonably necessary for the preservation, protection, or disposition of the termination inventory.

- 2.4.7 Except for normal spoilage, and except to the extent that NJ TRANSIT expressly assumed the risk of loss, the Contracting Officer shall exclude from the amounts payable to the Contractor under Sub-article 2.4.6 above, the fair value, as determined by the Contracting Officer, of property that is destroyed, lost, stolen, or damaged so as to become undeliverable to NJ TRANSIT or to a buyer.
- 2.4.8 The cost principles and procedures of Part 31 of the Federal Acquisition Regulation, in effect on the date of this contract, shall govern all costs claimed, agreed to, or determined under this clause.
- 2.4.9 The Contractor shall have the right of appeal, under the Disputes clause, from any determination made by the Contracting Officer under Sub-article 2.4.4, 2.4.6, or 2.4.11, except that if the Contractor failed to submit the termination settlement proposal within the time provided in Sub-article 2.4.4 or 2.4.11, and failed to request a time extension, there is no right of appeal. If the Contracting Officer has made a determination of the amount due under Sub-article 2.4.4, 2.4.6, or 2.4.11, NJ TRANSIT shall pay the Contractor (i) the amount determined by the Contracting Officer if there is no right of appeal or if no timely appeal has been taken, or (ii) the amount finally determined on an appeal.
- 2.4.10 In arriving at the amount due the Contractor under this clause, there shall be deducted:
- (a) All unliquidated advance or other payments to the Contractor under the terminated portion of this Contract;
  - (b) Any claim which NJ TRANSIT has against the Contractor under this contract; and
  - (c) The agreed price for, or the proceeds of sale of, materials, supplies, or other things acquired by the Contractor or sold under the provisions of this clause and not recovered by or credited to NJ TRANSIT.
- 2.4.11 If the termination is partial, the Contractor may file a proposal with the Contracting Officer for an equitable adjustment of the price(s) of the continued portion of the contract. The Contracting Officer shall make any equitable adjustment agreed upon. Any proposal by the Contractor for an equitable adjustment under this clause shall be requested within ninety (90) calendar days from the effective date of termination unless extended in writing by the Contracting Officer.
- 2.4.12 NJ TRANSIT may, under the terms and conditions it prescribes, make partial payments and payments against costs incurred by the Contractor for the terminated portion of the contract, if the Contracting Officer believes the total of these payments will not exceed the amount to which the Contractor will be entitled. If the total payments exceed the amount finally determined to be due, the Contractor shall repay the excess to NJ TRANSIT upon demand, together with interest computed at the rate established by the Secretary of the Treasury under 50 U.S.C. App. 1215(b)(2). Interest shall be computed for the period from the date the

excess payment is received by the Contractor to the date the excess is repaid. Interest shall not be charged on any excess payment due to a reduction in the Contractor's termination settlement proposal because of retention or other disposition of termination inventory until ten (10) calendar days after the date of the retention or disposition, or a later date determined by the Contracting Officer because of the circumstances.

2.4.13 Unless otherwise provided in this contract, or by statute, the Contractor shall maintain all records and documents relating to the terminated portion of this Contract for three (3) years after final settlement. This includes all books and other evidence bearing on the Contractor's costs and expenses under this contract. The Contractor shall make these records and documents available to NJ TRANSIT, at the Contractor's office, at all reasonable times, without any direct charge. If approved by the Contracting Officer, photographs, microphotographs, or other authentic reproductions may be maintained instead of original records and documents.

## 2.5 TERMINATION FOR CAUSE

2.5.1 In the event that any of the provisions of this Contract are violated by the Contractor, or any of its Subcontractors, the Contracting Officer may serve written notice upon the Contractor and Surety of NJ TRANSIT's intention to terminate the Contract for cause. The Notice of Intent to Terminate for Cause shall identify the causes for the proposed termination and demand the elimination of such causes.

2.5.2 If the Contractor or Surety, within a period of ten (10) calendar days after such notice or within such additional time as may be granted by the Contracting Officer, does not proceed in accordance therewith to make satisfactory arrangements to eliminate the causes of the proposed termination, then the Contracting Officer may terminate the Contract for cause.

2.5.3 The Notice of Termination for Cause will terminate the Contractor's right to proceed with all items of work except as specified in the termination notice. The latter will include all work necessary to ensure the safety of the public, to properly secure existing work already constructed or partially constructed, and to secure the Job Site. The work specified in the notice shall be performed in accordance with the Contract Documents and may include items of work not in the original Contract. Unless otherwise specified in the notice, all insurance policies provided by the Contractor naming NJ TRANSIT and any other parties as additional insureds shall remain in full force and effect until issuance by NJ TRANSIT of a Final Certificate of Payment.

2.5.4 Payment for completed or partially completed items of Work shall be made in accordance with the Contract Documents. Payment for new items, if any, will be paid either at agreed prices or paid for by Time and Material methods described in Sub-article 3.2.7. No other costs or compensation will be allowed the Contractor.

- 2.5.5 When all work specified in the termination notice is completed to the satisfaction of NJ TRANSIT, the Contract shall terminate upon issuance by NJ TRANSIT of a Final Certificate of Payment.
- 2.5.6 Upon issuance of a Notice of Termination for Cause, the Surety shall have ten (10) calendar days to advise NJ TRANSIT in writing that it intends to take over and complete the Project in accordance with the Contract terms and conditions, without any further conditions. If so notified, the Surety shall have thirty (30) calendar days from such notice to commence the work. Upon the Surety's failure to comply with either of the above, NJ TRANSIT may take over the work and prosecute the same to completion by contract with another contractor, or use whatever methods it deems necessary to complete the work, including completion of the Work by its own forces for the account and at the expense of the Contractor. NJ TRANSIT may take possession of and utilize in completing the work such materials, appliances and plants as may be on the site of the work and necessary therefor.
- 2.5.7 Whether the Contract Work is completed by NJ TRANSIT, either directly or through other contractors, or the Surety, the Contractor and its Surety shall be liable to NJ TRANSIT for excess costs incurred by NJ TRANSIT and other such damages arising out of the Termination for Cause including liquidated damages caused by the delay to the date of completion of the Project Work.
- 2.5.8 All such costs and damages incurred by NJ TRANSIT will be deducted from any monies due or that may become due the Contractor and Surety. If such costs and damages exceed the sum which is available, then the Contractor and the Surety shall be liable and shall pay NJ TRANSIT within thirty (30) calendar days of the issuance of an invoice for the amount of such excess.
- 2.5.9 In terminating the Contract for cause NJ TRANSIT does not waive its right to sue the Contractor and/or Surety for any costs incurred or damages suffered by NJ TRANSIT as a result of the Contractor's default and termination.
- 2.5.10 If, after a Notice of Termination for Cause has been issued, it is determined for any reason that the provisions of the Contract were not violated by the Contractor, or any of its Subcontractors, or if the termination of the Contract for Cause pursuant to the provisions of this Article is found by a court to be legally improper, then the termination of the Contract for cause will be treated as if it had been a termination for convenience and such termination shall be compensated for in accordance with the provisions of Article 2.4.

### **3. CONTRACT CHANGES**

#### **3.1 CHANGE ORDERS**

- 3.1.1 The Contracting Officer, at the Contracting Officer's sole discretion, may at any time during the progress of the work authorize additions, deductions, or changes to the Work as set forth below, and the Contract shall not be terminated or the surety released thereby. When changes in the work must be performed

immediately, the Contracting Officer may issue a written directive to the Contractor detailing the changed work and the basis for determining compensation, and the Contractor will proceed immediately with the Work as directed, pending the execution of a formal Change Order.

If any such change causes an increase or decrease in the cost of the performance of any part of the Work or requires a change in the Contract Time, then a Change Order shall be issued incorporating the change. All Change Orders shall be priced in accordance with Article 3.2. The Change Order shall be a written order to the Contractor and shall describe the change with cost changes and changes to Contract Time. The Change Order shall be signed by the Contractor and returned to NJ TRANSIT. Upon receipt, the Change Order shall be countersigned by the Contracting Officer and shall then become a part of the Contract Documents.

In the event the Contractor and NJ TRANSIT cannot, for whatever reason, reach an agreement on cost changes or changes to Contract Time, the Contracting Officer shall issue a unilateral Change Order incorporating the change and the Contractor shall nonetheless proceed with the Work as directed therein. The unilateral Change Order shall then become a part of the Contract Documents.

- 3.1.2 The Construction Manager shall have the authority to order, in writing, minor changes in the work not involving an adjustment to the price of any items of work or an extension of time and not inconsistent with the intent of the Contract. Such changes shall be binding on NJ TRANSIT and the Contractor, and shall not be the basis of increased compensation to the Contractor. Such work shall be executed under the conditions of the original Contract.
- 3.1.3 All additions, deductions or changes to the work as directed by Change Orders shall be executed under the conditions of the original Contract. The Change Order shall recite the additional time granted by NJ TRANSIT to perform the Work, if any. Except as specified in Sub-article 3.1.2 above, or in an emergency endangering life or property, no change shall be made unless pursuant to a written directive of the Contracting Officer or Change Order, and no claim for an addition to the Contract Price or time shall be valid unless so ordered.
- 3.1.4 Should the Contractor dispute the Construction Manager's interpretation of work specified in the Contract Documents and claim that work is Extra Work that will involve additional costs or Contract Time, the Contractor shall proceed with the work in accordance with the Construction Manager's interpretation. In such event, the Contractor shall follow the procedures and maintain the detailed cost records set forth in Article 3.3-T&M CHANGE ORDER RECORDS pending the resolution of the dispute. In all other cases, should the Contractor perform Extra Work without first obtaining a written directive or Change Order from the Contracting Officer's authorized representative, such action shall be construed by NJ TRANSIT as voluntary performance and as a waiver of any and all claims to extra payment and time therefor.



3.1.5 The time needed to perform Extra Work shall not be the basis of claims by the Contractor for extra costs of any nature whatsoever.

3.2 CHANGE ORDER PRICING

3.2.1 Proposed additions, deductions and changes shall be defined in a Notice of Proposed Change (NPC) and issued to the Contractor. The Contractor's proposal for all proposed additions, deductions and changes to the work involving cost or Contract Time shall be submitted by the Contractor to the Construction Manager with copies to the Contracting Officer and Project Manager within fifteen (15) calendar days, or such other time as the Construction Manager may direct, after the issuance of the Notice of Proposed Change. The Contractor's cost proposal shall be structured in accordance with the format(s) set forth below and shall comply with the pricing specifications set forth in this Article 3.2. NJ TRANSIT shall review the Contractor's proposal and, if necessary, meet with the Contractor to negotiate the proposal. Should the Contracting Officer require additional information, the Contractor will provide the requested information. The Contractor's costs for preparing, submitting, and negotiating proposals will not be paid separately and shall not be included in the proposals, but shall be considered paid for in the Contract Price.

<b>Table 3.2.1: Change Order Cost Proposal Format</b>		
I	II	III
LABOR <sup>1</sup>	Cost Calculation	Summary of Costs
Name Each Trade Classification	(Manhours) x (Labor Costs) =	A
MATERIAL <sup>2</sup>		
Name Each Major Type of Material	(Quantity) x (Unit Costs) =	B
EQUIPMENT <sup>3</sup>		
Name Each Major Piece of Equipment	(Time) x (Unit Costs) =	C
SUBTOTAL	A + B + C =	D
OVERHEAD <sup>4</sup>	(D) x (Overhead %) =	E
PROFIT <sup>5</sup>	(D) x (Profit %) =	F
TOTAL	D + E + F =	G
Footnotes: <sup>1</sup> Labor Costs as specified in Sub-article 3.2.9.1 <sup>2</sup> Material Costs as specified in Sub-article 3.2.9.2 <sup>3</sup> Equipment Costs as specified in Sub-article 3.2.9.3 <sup>4</sup> Overhead Markups as specified in Article 3.2.9.4 <sup>5</sup> Profit Markups as specified in Article 3.2.9.6		

3.2.2 Requests for extension of time for proposed Change Order work shall be included in the Contractor's proposal. Extensions of time will not be granted unless requested in accordance with the provisions of Subarticle 3.2.1.

- 3.2.3 Full documentation supporting all estimated and actual costs shall be furnished to the Construction Manager or Contracting Officer if such is requested. Documentation may consist of records such as actual payroll records and receipted bills for rentals and materials. All Change Orders shall be subject to audit by the Contracting Officer or the Contracting Officer's authorized representative.
- 3.2.4 All proposed and incurred change order costs shall as a minimum be allowable, allocable and reasonable in accordance with the Contract cost principles and procedures in Part 31 of the Federal Acquisition Regulations in effect on the date of the Contract. The Contracting Officer's determination on the allowability, allocability and reasonableness of incurred costs shall be final and conclusive.
- 3.2.5 The value of any change in the Contract shall be determined in accordance with the following pricing bases, listed in the order of priority of use: a) Unit Price, b) Lump Sum and c) Time and Material (T&M). Unit Prices shall govern if contained in the Bidder's Proposal for the applicable work. If no Unit Prices apply, then a Lump Sum pricing approach shall be used. If a Lump Sum cannot be determined, or agreement cannot be reached, or the Contracting Officer determines that work must be performed immediately, then the Contracting Officer will direct the Contractor to proceed on a T & M basis. Whenever the terms "labor", "materials", "equipment", "overhead" and "profit" are used herein with regard to change order cost and price proposals, they are used as these cost and price elements are defined in this Article 3.2.
- 3.2.6 Unit Price Basis: Whenever unit prices govern, the Contractor's cost proposal shall identify the additional estimated quantities required for the work. The unit price included in the Contract, or subsequently agreed upon, shall be used to solely determine the increased or decreased cost of the work. The unit price shall be deemed to include all costs for labor, material, overhead and profit and the increase or decrease in the cost of the work shall be on a dollar for dollar basis.
- 3.2.7 Lump Sum Basis: When unit prices do not apply, the Contractor shall submit a detailed breakdown of labor, materials, and equipment. The Contractor shall add to this overhead and profit markups as specified in Sub-article 3.2.10. Cost proposals for labor and material shall be provided on the stationary of the parties that will be performing the work (Subcontractors) and supplying material (suppliers).
- 3.2.8 Time and Material: The Contractor shall submit the same detailed breakdown of costs as set forth in Sub-article 3.2.7 for Lump Sum change orders. In addition, the Contractor shall submit a Guaranteed Maximum Price (GMP) which may be accepted or rejected by the Contracting Officer.
- 3.2.8.1 Time and Material with GMP: If the Guaranteed Maximum Price is accepted, the payment for such work shall not exceed the actual cost for labor, materials, and equipment. To this may be added overhead and profit mark-ups both as specified in Sub-article 3.2.10. However, in no event shall payment exceed the Guaranteed Maximum Price established by agreement between the Contractor and NJ TRANSIT.

3.2.8.2 Time and Material with Upset Price: If the Guaranteed Maximum Price submitted by the Contractor is rejected, NJ TRANSIT may direct the Contractor to proceed on a time and material basis with an Upset Price established by NJ TRANSIT. The Upset Price shall be the limit of authorization for performance of the Extra Work by the Contractor. At such time as the Contractor has expended eighty percent (80%) of the authorized limit, NJ TRANSIT may establish a new limit by revising the Upset Price. However, if NJ TRANSIT chooses not to establish a revised Upset Price, the Contractor shall cease the time and material work when the original Upset Price has been reached. The payment for such work shall include the actual cost for labor, materials and equipment and may also include added overhead and profit mark-ups as specified in Sub-article 3.2.10.

3.2.8.3 Emergent Time and Material: Should the Contracting Officer determine that changed work must be performed immediately, and NJ TRANSIT determines that the Contractor has insufficient time to submit a detailed cost proposal in advance of performing the work, NJ TRANSIT may direct the Contractor to proceed on an emergent time and material basis with an Upset Price established by NJ TRANSIT. The terms of performance and payment shall be as set forth in Sub-article 3.2.8.2, except that profit markups shall be as specified in Sub-article 3.2.10.

3.2.9 NJ TRANSIT will consider for payment only the labor, material and equipment cost elements as specified herein in conjunction with any cost proposal submitted by the Contractor. These cost elements, individually or together, shall serve as the cost basis upon which applicable markups for profit and overhead shall be applied, all as specified in Sub-article 3.2.10. These costs elements, together with the applicable markups for profit and overhead, shall constitute full compensation for all direct and indirect costs and shall be deemed to include all items of expense not specifically designated.

3.2.9.1 Labor Costs

- a) For necessary labor and foremen in direct charge of the specific operations, whether the employer is the Contractor, subcontractor or another, the Contractor shall receive the rate of wage (or scale) actually paid as shown in its certified payrolls for each and every hour that said labor and foremen are actually engaged in such work.
- b) The Contractor shall also receive the actual costs paid to, or in behalf of, workers by reason of health and welfare benefits, pension fund benefits or other benefits, when such amounts are required by collective bargaining agreements or other employment contracts, or the Contract prevailing wage determination, generally applicable to the classes of labor employed on the work.
- c) The Contractor shall receive the actual cost paid to applicable State and Federal agencies and insurance carriers for Worker's Compensation Insurance, Federal Insurance Compensation Act (FICA, Social Security), Unemployment Insurance and Contractor's General Liability and Worker's Disability.

3.2.9.2 Material Costs: Only materials furnished by the Contractor and necessarily used in the performance of the work will be paid for. The cost of such materials will be the cost to the purchaser, whether Contractor, subcontractor or other forces from the supplier thereof, together with transportation charges actually paid by the Contractor, except as the following are applicable.

- (a) If a cash or trade discount by the actual supplier is offered or available to the purchaser, it shall be credited to NJ TRANSIT notwithstanding the fact that such discount may not have been taken.
- (b) If materials are procured by the purchaser by any method which is not a direct purchase from and a direct billing by the actual supplier to such purchaser, the cost of such materials shall be deemed to be the price paid to the actual supplier as determined by NJ TRANSIT plus the actual costs, if any, incurred in the handling of such materials.
- (c) If the materials are obtained from a supply or source owned wholly or in part by the purchaser, the cost of such materials shall not exceed the price paid by the purchaser for similar materials furnished from said source on Contract Items or the current wholesale price for such materials delivered to the job site, whichever price is lower.
- (d) If the cost of such materials is, in the opinion of NJ TRANSIT, excessive, then the cost of such material shall be deemed to be the lowest current wholesale price at which such materials are available in the quantities concerned delivered to the job site, less any discounts as provided in Subparagraph (a) above.
- (e) If the Contractor does not furnish satisfactory evidence of the cost of such materials from the actual supplier thereof, the cost shall then be determined in accordance with Paragraph (d) above.

NJ TRANSIT reserves the right to furnish such materials as it deems advisable, and the Contractor shall have no claims for costs and markups on such materials.

3.2.9.3 Equipment and Plant Rental Costs:

- (a) Contractor Owned Equipment and Plant - The hourly rates for Contractor owned equipment and plant will be based on "Rental Rate Blue Book for Construction Equipment" or the "Rental Rate Blue Book for Older Construction Equipment" (both referred to hereafter as the "Blue Book"), published by Nielsen/DATAQUEST, Inc. of Palo Alto, California. The Blue Book shall be used in the following manner:
  - (1) The hourly rate will be determined by dividing the "monthly" rate set out in the Blue Book by 176. The "weekly," "hourly," and "daily" rates listed in the Blue Book will not be used.
  - (2) The number of hours to be paid for shall be the number of hours that the equipment or plant is actually used on a specific activity.
  - (3) The "current revisions" to the Blue Book will be used in establishing rates. The "current revision" applicable to specific Change Order work will be the "current revision" as of the first day of work performed on that Change Order work and that rate will apply throughout the period the Change Order work is being performed.

- (4) Area adjustments will not be made. Equipment life adjustments will be made in accordance with the rate adjustment tables.
- (5) Overtime shall be charged at the same rate indicated in (1), above.
- (6) The "estimated operating costs per hour" shall be used for each hour that the equipment or plant is in operation on the Change Order work. No such costs shall apply to idle time regardless of the cause of the idleness.
- (7) Idle time for equipment will not be paid for, except where the equipment has been held on the Project site on a standby basis at the request of NJ TRANSIT and, but for this request, would have left the Project site. Such payment will be made at one half (1/2) the rate established in (1), above.
- (8) The rates as established above shall be deemed to include the cost of fuel, oil, lubrication, supplies, small tools, necessary attachments, repairs, overhaul, and maintenance of any kind, depreciation, storage, overhead, profits, insurance, costs of moving equipment or plant on to and away from the site, and incidentals (including labor and equipment).
- (9) Operator costs shall be paid only as provided in Sub-article 3.2.9.1, "Labor," of this Article.

Equipment shall be in good operating condition and suitable for the work, in the opinion of the Construction Manager. Equipment used by the Contractor shall be specifically described and be of suitable size and capacity required for the work to be performed. In the event the Contractor elects to use equipment of a higher rental value than that suitable for the work, payment will be made at the rate applicable to the suitable equipment. The equipment actually used and the suitable equipment paid for will be recorded as a part of the record for Change Order work. If there is a differential in the rate of pay of the operator of oversize or higher rate equipment, the rate paid for the operator will likewise be that for the suitable equipment.

In the event that a rate is not established in the Blue Book for a particular piece of equipment or plant, NJ TRANSIT shall establish a rate for that piece of equipment or plant that is consistent with its cost and use.

The provisions of this Subparagraph (a), "Contractor Owned Equipment and Plant" shall apply to the equipment and plant owned directly by the Contractor or by entities which are divisions, affiliates, subsidiaries or in any other way related to the Contractor or its parent company.

- (b) Rented Equipment and Plant - In the event that the Contractor does not own a specific type of equipment and must obtain it by rental, it shall be paid the actual rental for the equipment for the time that the equipment is actually used to accomplish the work, plus the cost of moving the equipment on, to, and away from the job. The Contractor shall provide a copy of the paid receipt for the rental expense incurred.

3.2.9.4 Overhead Costs: Overhead shall be defined to include any and all Contractor Field Office and Home Office overhead and operating expenses whatsoever. Overhead includes, as a minimum, the following categories of expense, regardless of whether or not the Contractor's accounting system allocates such expenses on a direct or indirect basis:

- (a) Salary and expenses of all Field Office employees, including project managers, supervising officers, supervising employees, superintendents, technical, scheduling or engineering employees, draft persons and clerical or stenographic employees;
- (b) Charges for minor equipment, small tools, and other miscellaneous supplies and expenses, including computers and telephones, personal protection equipment, shovels, picks, axes, saws, bars, sledges, lanterns, jacks, cables, pails, wrenches, etc.;
- (c) Charges for trailer rentals, utility and other temporary facility rental and maintenance charges, monthly utility charges, and all other costs to operate and maintain Contractor's Field Office unless otherwise provided as a direct charge elsewhere in the contract.
- (d) Salary and expenses of Home Office employees, including executive officers, managers, professional and administrative staff, and clerical and support staff;
- (e) Charges and expenses for drafting, Computer Assisted Design, scheduling, billing, financing, etc.
- (f) All other costs to operate and maintain the Contractor's Home Office.
- (g) Bond and insurance costs described in Sub-article 3.2.9.5.

The Contractor agrees that its overhead costs will be fully and fairly compensated by the fixed, non-negotiable overhead percentage markups set forth in Sub-article 3.2.10.

3.2.9.5 Bond and Insurance: Compensation for bond premiums and other insurance premiums not listed in Sub-article 3.2.9.1 shall be considered paid for under the overhead percentages added to the sum of the actual cost for labor, material and equipment and will not be considered or paid separately by NJ TRANSIT.

3.2.9.6 Profit: The Contractor's profit shall be negotiated as a percentage markup based on the type of work, the value of the change, the pricing basis and the amount of risk to the Contractor associated with the work to be performed. The Contractor agrees that the profit percentage markups are subject to negotiation on each change. However under no circumstances shall negotiated markups exceed the maximum allowable markup set forth in Sub-article 3.2.10.

3.2.10 Overhead and profit markups on each change shall be calculated in accordance with this Sub-article 3.2.10. Where work is performed by Subcontractors at any tier, the Contractor shall reach an agreement with such Subcontractors as to the distribution of payments, including overhead and profit markups made by NJ TRANSIT for such work. No additional payment therefor will be made by NJ TRANSIT by reason of the performance of the work of any Subcontractor.

- 3.2.10.1 When work is to be added or deleted on a Unit Price basis, the Unit Price shall govern and is deemed to include all markups for overhead and profit. No additional markups for overhead and profit will be allowed. When a complete Bid Item is deleted, it shall be treated as a Unit Price Bid item (regardless of whether it is a Lump Sum or Unit Price item) and the total Bid price for that item shall be deducted from the Contract Price.
- 3.2.10.2 When work is to be added on a lump sum or time and material basis, markups for profit and overhead shall be as specified in Table 3.2.10.
- 3.2.10.3 When work is to be deleted on a lump sum or time and material basis, markups specified in Table 3.2.10, for overhead costs that will not be incurred and profit that would have been realized if the work had not been deleted, shall be included in the deductive cost proposal submitted by the Contractor. If the Contractor's deductive cost proposal does not include an amount for overhead and profit, the Contracting Officer will add the markups specified in Table 3.2.10 to the cost proposal. When work is to be deleted, the Contractor may include documented cancellation and restocking charges and subtract those charges from the cost basis of the deductive cost proposal.
- 3.2.10.4 When work is to be both added and deleted on a lump sum or time and material basis, the cost basis shall be determined first by calculating both the added and deleted labor, material and equipment costs. Overhead and profit markups specified in Table 3.2.10 shall be applied to:
- a) Net increase in cost basis, in which case Paragraph 3.2.10.2 shall govern;
  - b) Net decrease in cost basis, in which case Paragraph 3.2.10.3 shall govern.

Should there be a net change in cost basis of zero, there will be no change in the Contract Price.

- 3.2.10.5 When there is a change only to the material being supplied and no additional labor cost will be incurred by the Contractor or Subcontractors at any tier, markups for overhead and profit shall be as specified in Table 3.2.10.
- 3.2.10.6 When a change is authorized for standby time, markups for overhead and profit shall be as specified in Table 3.2.10. Any claim for standby time will be rejected unless documented by time sheets signed by the Inspector.
- 3.2.10.7 When a change is authorized for overtime and the work to be performed is an established item of work, markups for overhead and profit shall be as specified in Table 3.2.10 and shall be applied only to the premium portion of labor costs.

<b>Table 3.2.10: Maximum Overhead and Profit Markups for Added Work</b>				
Work Performed By	Change Order Pricing Basis	Cost Basis	Overhead Markup (as a % of Cost Basis)	Maximum Profit Markup (as a % of Cost Basis)
Contractor	Lump Sum or T&M with GMP	Contractor labor, material and equipment costs	10%	10%
Subcontractor (at any tier)	Lump Sum or T&M with GMP	Subcontractor labor, material and equipment costs	15% (to be shared between Contractor and Subcontractors)	15% (to be shared between Contractor and Subcontractors)
Contractor	T&M with NJT Upset Price	Contractor labor, material and equipment costs	10%	5%
Subcontractor (at any tier)	T&M with NJT Upset Price	Subcontractor labor, material and equipment	15% (to be shared between Contractor and Subcontractors)	7.5% (to be shared between Contractor and Subcontractors)
Contractor	Emergent T&M	Contractor labor, material and equipment costs	10%	7.5%
Subcontractor (at any tier)	Emergent T&M	Subcontractor labor, material and equipment costs	15% (to be shared between Contractor and Subcontractors)	10% (to be shared between Contractors and Subcontractors)
No Additional Labor	Lump Sum All T&M's	Only Material Costs	2.5%	2.5%
Standby Time	T&M Only	Labor Costs Only	5%	5%
Overtime	T&M Only	Premium Labor Costs Only	5%	5%

### 3.3 TIME AND MATERIAL (T&M) CHANGE ORDER RECORDS

3.3.1 The Contractor shall maintain its records in such a manner as to provide a clear distinction between the direct costs of T & M work and the costs of other Work.

From the above records, the Contractor shall furnish the Construction Manager completed daily work reports for each day's work to be paid for on a T & M basis. The daily T & M work reports shall be detailed as follows:

- (a) Name, classification, date, daily hours, total hours, rate, and extension for each laborer and foreman.
- (b) Designation, dates, daily hours, total hours, rental rate, and extension for each unit of machinery and equipment.
- (c) Quantities of materials, prices, and extensions.
- (d) Transportation of materials.
- (e) Cost of property damage, liability, and worker's compensation insurance premiums, unemployment insurance contributions, bonds, and social security tax.

3.3.2 Material charges shall be substantiated by valid copies of vendor's invoices. Such invoices shall be submitted with the daily work reports, or if not available, they shall be submitted with subsequent daily



T & M work reports. Should said vendor's invoices not be submitted within sixty (60) calendar days after the date of delivery of the material, NJ TRANSIT reserves the right to establish the cost of such materials at the lowest current wholesale prices at which said materials are available, in the quantities concerned delivered to the location of work less any discounts provided in Sub-article 3.2.9.2(a), above.

- 3.3.3 Said daily time and material work reports shall be signed by the Contractor or its authorized representative.
- 3.3.4 The Construction Manager will compare NJ TRANSIT's records with the completed daily time and material work reports furnished by the Contractor and make any necessary adjustments. Except when daily time and material work reports are submitted for the purpose of recording the cost of disputed items of work, as required under Sub-article 3.1.4, when daily time and material work reports are agreed upon and signed by both parties, said reports shall become the basis of payment for the work performed, but shall not preclude subsequent adjustment based on a later audit by NJ TRANSIT. In the case of disputed items of work, the signature of NJ TRANSIT's Construction Manager represents only the Construction Manager's concurrence with the costs allocated by the Contractor to the disputed work and shall not preclude the Contracting Officer from disputing such work.

#### 3.4 CONTRACTOR INITIATED CHANGE ORDERS

- 3.4.1 The Contractor may request a change order for an increase in the cost of the performance of any part of the Work or a change in the Contract Time only when such costs or time impacts are attributable to the following:
  - a.) Latent errors and omissions in the contract documents;
  - b.) Additional costs or an extension of Contract time for which a change order is expressly permitted under any Article in this Contract.

The Contractor must give immediate notice to the Construction Manager when it becomes aware of the condition causing the initiation of a request for change.

- 3.4.2 Contractor Initiated Change Order Requests (CICOR's) will not be considered unless the Contractor has strictly complied with the notice requirements of the appropriate Articles of this Contract. The Contractor further understands and agrees that neither the procedure established under this Article nor the review of CICOR's by NJ TRANSIT pursuant hereto shall in any way affect the requirements of the filing of a Notice of Claim or the filing of a suit pursuant to the provisions of N.J.S.A. 59:13-1 et seq.
- 3.4.3 Within fifteen (15) calendar days of notification by the Contractor of a condition causing the initiation of a request for change, the Contractor must submit the CICOR with sufficient detail to enable NJ TRANSIT to ascertain the basis and amount of said request. As a minimum, the following information must accompany each request submitted pursuant to the provisions of this Sub-article:

- (a) A detailed factual statement of the CICOR providing all necessary dates, locations and items of work affected by the CICOR;
- (b) The date on which facts arose which gave rise to the CICOR;
- (c) The name, function, and activity of each NJ TRANSIT individual, official or employee involved in or knowledgeable about such CICOR;
- (d) The specific provisions of the Contract which support or mitigate against the CICOR and a statement of the reasons why such provisions support or mitigate against the CICOR;
- (e) If the CICOR relates to a decision of NJ TRANSIT or the Construction Manager which the Contract leaves to NJ TRANSIT's or the Construction Manager's discretion or as to which the Contract provides that NJ TRANSIT's or the Construction Manager's decision is final, the Contractor shall set out in detail all facts supporting its contention that the decision of NJ TRANSIT or the Construction Manager was fraudulent or capricious or arbitrary or is not supported by substantial evidence;
- (f) The identification of documents and the substance of oral communications relating to such CICOR;
- (g) A statement as to whether the additional compensation or extension of time sought is based on the operation of the provisions of the Contract or an alleged breach of contract;
- (h) If an extension of time is sought, the specific days for which it is sought and the CPM schedule data providing a logical basis for such an extension;
- (i) If additional compensation is sought, the exact amount sought and a breakdown of that amount in accordance with the pricing specifications set forth in Article 3.2.

It will be the responsibility of the Contractor to furnish within a reasonable time such further information and details as may be required by NJ TRANSIT to determine the facts or contentions involved in the CICOR's, including but not limited to those items identified in Article 3.5.

### 3.5 AUDIT OF CHANGE ORDERS

3.5.1 The cost records of the Contractor and its Subcontractors pertaining to change orders shall be open to inspection or audit by representatives of NJ TRANSIT during the life of the Contract and for a period of not less than three years after the date of acceptance thereof, and the Contractor and its Subcontractors shall retain such records for that period. This audit provision shall apply whether or not such change orders are part of a suit pending in the courts of this State pursuant to the New Jersey Contractual Liability Act. The audit may be performed by employees of NJ TRANSIT or by an auditor under contract with NJ TRANSIT. The audit may begin with ten (10) calendar days notice to the Contractor or its Subcontractor. The Contractor or Subcontractor shall provide adequate facilities, acceptable to NJ TRANSIT, for such audit during normal business hours. The Contractor or its subcontractor shall make a good faith effort to cooperate with the auditors.

- 3.5.2 If an audit is to be commenced more than sixty (60) calendar days after the acceptance date of the Contract, the Contractor will be given a reasonable notice of the time when such audit is to begin.
- 3.5.3 As a minimum, the Contractor shall maintain and the auditors shall have available to them the following documents:
- (a) daily time sheets and foreman's daily reports.
  - (b) union agreements.
  - (c) insurance, welfare and benefits records.
  - (d) payroll registers.
  - (e) earnings records.
  - (f) payroll tax forms.
  - (g) material invoices and/or requisitions.
  - (h) material cost distribution worksheet.
  - (i) equipment records (list of company equipment, rates, etc.)
  - (j) vendors', rental agencies', and subcontractors' invoices.
  - (k) subcontractors' payment certificates.
  - (l) canceled checks (payroll and vendors).
  - (m) job cost report.
  - (n) job payroll ledger.
  - (o) general ledger.
  - (p) cash disbursements journal.
  - (q) financial statements for all years reflecting the operations on this Project.
  - (r) income tax returns for all years reflecting the operations on this Project.
  - (s) depreciation records on all company equipment whether such records are maintained by the company involved, or its accountant, or others.
  - (t) if a source other than depreciation records is used to develop costs for the Contractor's internal purposes in establishing the actual cost of owning and operating equipment, all such other source documents.
  - (u) all documents which reflect the Contractor's actual profit and overhead during the years this Project was being performed and for each of the five years prior to the commencement of this Project.
  - (v) all documents related to the preparation of the Contractor's Bid including the final calculations on which the Bid was based.
  - (w) all documents which relate to each and every change order together with all documents which support the amount of claimed costs.
  - (x) worksheets used to prepare the CICOR or cost proposal tracing the cost elements of the change order (including, but not limited to, labor, benefits and insurance, materials, equipment and subcontractors) to the primary records which establish the time periods, individuals, hours, rates, materials and equipment involved in the change order.

### 3.6 SUPPLEMENTAL CONSTRUCTION COSTS

Whenever the Bid Item "Supplemental Construction Costs" appears in the Bidder's Proposal, NJ TRANSIT has provided an allowance for additional or supplemental construction work that it has not yet defined. This allowance is provided for the sole convenience of NJ TRANSIT and can only be used for work authorized by NJ TRANSIT.

All additional or supplemental work authorized under this provision will be incorporated into the Contract by Change Order pursuant to Article 3.1. The Change Order will describe the additional or supplemental work with any associated cost changes and will reduce the Supplemental Construction Cost allowance in the amount specified in the Change Order. Residual amounts remaining in the Supplemental Construction Cost Allowance Bid Item at Final Completion will be deleted from the Contract Amount by NJ TRANSIT.

## 4. PROTECTION AND CONTROL OF PREMISES

### 4.1 RESPONSIBILITY FOR WORK

4.1.1 The Contractor shall be responsible for damages arising from its work on the Project, to any part of the Project work, both temporary and permanent, to adjoining property and to NJ TRANSIT property both within and outside the project limits. The Contractor shall, at its own expense, protect finished work susceptible to damage and keep the same protected until the Project is completed and accepted by NJ TRANSIT.

4.1.2 All Contractor and Sub-Contractor personnel are required to carry, and display when requested, a form of photo identification acceptable to NJ TRANSIT.

4.1.3 The Contractor shall make, use, and provide proper, necessary, and sufficient precautions, safeguards, and protection against the occurrence of accident, injury, damage or hurt to person or property during the progress of the work. The Contractor alone shall be responsible for the safety, efficiency, and adequacy of its plant, appliances, and methods, and for damage or injury which may result from its failure to act in a safe, careful, efficient, and workmanlike manner. Any action or direction by NJ TRANSIT or its representatives relating to the adequacy or implementation of the Contractor's precautions, safeguards, and protection shall in no manner relieve the Contractor of any of its obligations or responsibilities hereunder.

4.1.4 In case of an emergency which threatens persons or property, the Contractor shall act, without previous instructions from the Construction Manager, in a diligent and proper manner to remedy the situation. The Contractor shall notify the Construction Manager immediately. During non-standard work hours (See Sub-Article 4.2.9 for Standard Work Hours) the Rail or Bus Control Center, as appropriate, shall be notified. Claims for compensation by the Contractor for Extra Work arising from emergencies not caused by the Contractor shall be documented and promptly submitted for review and approval. Where the Contractor has notified the Construction Manager of such emergency but has not taken any action, it shall act as instructed or authorized by the Construction Manager.

## 4.2 USE OF PREMISES

4.2.1 Prior to the use of NJ TRANSIT premises, the Contractor shall obtain the approval of the Construction Manager for the Contractor's staging area(s), access and egress to the premises, parking area(s) for Contractor vehicles and equipment, elevator use, and any other use of NJ TRANSIT property, facilities, or on site utilities. The Contractor shall notify the Construction Manager no later than 72 hours in advance of any utility shutdowns that affect NJ TRANSIT facilities. All cut overs of existing mechanical and electrical services shall be done at a time convenient to NJ TRANSIT and any other private or public agency having jurisdiction, so as not to interfere with facility operations.

4.2.2 The Contractor shall comply with the rules and regulations of NJ TRANSIT. The Contractor shall confine its apparatus, the storage of materials and the operations of workmen to limits indicated by law, ordinances, permits, contract limit lines as established, or directions of the Construction Manager and shall not unreasonably encumber the premises with its materials. The Contractor shall maintain a reasonably clean job site free of debris and litter.

4.2.3 The Contractor shall be responsible for hoisting and distributing material and equipment throughout the Project for its work, and the work of its Subcontractors. The Contractor shall handle materials in a controlled manner with as few handlings as possible. The Contractor shall not drop or throw materials from heights. The Contractor shall not load or permit any part of a structure to be so loaded as might endanger its safety or integrity.

The Contractor agrees to NJ TRANSIT's use and occupancy of a portion or unit of the Project after the portion or unit has been declared Substantially Complete by NJ TRANSIT.

4.2.4 The Contractor shall request of and obtain from NJ TRANSIT specific instructions, rules and regulations regarding the required conduct of the Contractor during the construction so that the security and safety of personnel and property, including both NJ TRANSIT's and the general public's, will not be endangered. NJ TRANSIT will not allow an increase in the Contract amount due to the Contractor's failure to determine the conditions under which it must perform its contractual obligations. The Contractor shall enforce the Construction Manager's instructions regarding but not limited to signs, advertisements, fires, smoking, alcohol, safety and cleanliness on the site.

4.2.5 Accessibility to the work area shall be determined by the Contractor and approved by the Construction Manager, unless otherwise indicated in the Contract Documents. It is the Contractor's responsibility to make arrangements for use of public and/or private properties required to execute and complete the work under this Contract.

4.2.6 Space that the Contractor may require for plant, equipment, storage or other purposes, in addition to that available therefor at the site of the Project, shall be procured by the Contractor and the cost thereof is

considered to be included in the prices Bid for the various items scheduled in the Bid. In event of default, NJ TRANSIT has the right to take over and occupy such space, or cause it to be occupied, for the purpose of completing the Project, at the Contractor's expense. If leased, the lease shall contain a provision that in event of default by the Contractor the lease may be assigned to NJ TRANSIT or its nominee. The Contractor agrees, in event of said default, that it will make such assignment. At the time of execution, a copy of all lease agreements shall be submitted to the Construction Manager.

4.2.7 The Contractor shall provide watchmen service, when necessary or when directed by the Construction Manager throughout the period of construction, to adequately protect the work, stored materials and temporary structures located on the premises, and to prevent unauthorized persons from entering upon the construction site.

4.2.8 The Contractor shall adequately insure, secure and protect its own tools, equipment, materials and supplies.

4.2.9 Regular working hours are from 8:00 a.m. to 4:30 p.m., Monday through Friday. The Contractor shall obtain the written approval of the Construction Manager for performance of work other than during regular working hours or on weekends or Holidays. Standard NJ TRANSIT Holidays are as follows: New Year's Day, Martin Luther King Day, President's Day, Good Friday, Memorial Day (Monday observance), Independence Day, Labor Day, Thanksgiving Day and the day after, and Christmas Day. The Contractor shall advise the Construction Manager no less than ten (10) calendar days in advance of work to be performed during such times. This shall not preclude taking prudent and necessary actions in an emergency situation.

#### 4.3 MAINTENANCE AND CLEANING OF PREMISES

4.3.1 The Contractor shall maintain and clean the premises as necessary to ensure a safe, orderly and clutter-free working environment. The Contractor shall comply with the following cleaning requirements:

4.3.2 The Contractor shall retain all stored items in an orderly arrangement to allow maximum access, not impede drainage or traffic, eliminate fire hazards and provide proper protection of materials. Weekly, and more often if necessary, the Contractor shall inspect all material storage conditions on the site and restack, tidy, or otherwise service material storage conditions to maintain an orderly arrangement. Scrap, debris, waste materials, and other items not required for construction of the Work shall be regularly disposed of in accordance with the requirements set forth below. The Contractor shall wet down dry materials to minimize dust and prevent blowing dust. The Contractor shall maintain the site in a neat and orderly condition at all times.

4.3.3 The Contractor shall provide adequate storage for all items awaiting removal from the job site, observing all requirements for fire protection, health and protection of the environment. Combustible waste, scrap, rubbish, etc., shall be stored in properly sized metal containers (with metal covers where practical) pending removal from the premises. Pest control services shall be provided as necessary to control vermin, rodents

and other pests. Daily, and more often as necessary, the Contractor shall inspect the site and move all scrap debris and waste material to the place designated for their storage. At least once a week and more often if necessary, the Contractor shall completely remove and legally dispose of all scrap, debris and waste material from the job site. Placement of waste containers and carting schedules shall be submitted to the Construction Manager for the Construction Manager's review and approval. If the Contractor fails to remove debris from the site within seven (7) calendar days after it has been given written notice to do so by the Construction Manager, the Construction Manager will have the debris removed by others and the cost backcharged to the Contractor.

4.3.4 Weekly, and more often if necessary, the Contractor shall sweep all interior spaces clean. "Clean", for the purpose of this Subparagraph, shall be interpreted as meaning free from dust and other material capable of being removed by use of reasonable effort and a hand-held broom.

4.3.5 Preparatory to the installation of any succeeding materials, the Contractor shall clean all structures, or pertinent portions thereof, to the degree of cleanliness recommended by the manufacturer of the succeeding material, using all equipment and materials required to achieve the required cleanliness.

4.3.6 The Contractor shall schedule cleaning operations so that dust and other contaminants resulting from any cleaning process will not fall on wet, newly painted surfaces.

4.3.7 The Contractor shall schedule final cleaning, as approved by the Construction Manager, to enable NJ TRANSIT to accept a completely clean project. Prior to completion of Work, the Contractor shall remove from the job site all tools, surplus materials, equipment, scrap, debris and waste. The Contractor shall remove all traces of soil, waste material, mortar and paint droppings, grease and other foreign matter from all interior and exterior surfaces. All floor slabs shall receive a final steam cleaning.

#### 4.4 FIRE PREVENTION ON PREMISES

4.4.1 Each Contractor shall perform its work on or about the premises in a careful manner with full consideration to fire prevention as required by the New Jersey Uniform Fire Code (NJUFC), N.J.A.C. 5:71-1 et seq., and its referenced standards. Fire resistant materials shall be used for temporary enclosures. Storage of flammable materials on the site shall be subject to limitations specified in the NJUFC and the approval of the Construction Manager, and shall be the Contractor's responsibility. Accessibility to fire hydrants shall be maintained at all times. On site open burning of rubbish, garbage, trade waste, leaves or plant life is strictly prohibited by New Jersey law.

4.4.2 Chemical extinguishers approved by the Construction Manager shall be provided by the Contractor during the progress of the work where specified by the NJUFC or required by Fire Officials from the DCA Bureau of Fire Safety or the local fire department. In addition, the Contractor shall be responsible for furnishing and

maintaining his own extinguisher equipment in storage sheds, warehouses, Contractor's offices, and workmen's temporary buildings.

4.4.3 The Contractor shall maintain an active program of fire prevention to keep workers fire conscious during the entire Contract duration. It shall designate one member of its organization to execute and coordinate the fire control measures of its own organization, that of all Subcontractors under its jurisdiction and that of all other personnel at the site. It shall report to the Construction Manager any lack of cooperation or refusal to participate on the part of any worker or Subcontractor with regard to the fire prevention program. Failure of any worker or Subcontractor to cooperate with the Contractor in carrying out the above program shall be grounds for barring that individual or firm from the Project.

4.4.4 Temporary heating systems provided under Article 5.6 shall conform to the requirements of the NJUFC where the building is fully or partially occupied.

4.4.5 Where required under the NJUFC, the Contractor shall be responsible for obtaining required permits from the DCA Bureau of Fire Safety for flammable or combustible gas or liquid storage, fumigation/fogging, blasting, welding, burning, cutting and torch-applied roofing or paint removal.

#### 4.5 PROTECTION AGAINST DAMAGE

4.5.1 The Contractor shall protect existing property, structures, curbs, walks, drives, trees, shrubs, lawns, and landscape work on the site or affected by its activities from damage and shall provide such guards and covering as necessary. Damaged items shall be repaired or replaced at the Contractor's expense to the satisfaction of NJ TRANSIT. No extension of time will be allowed for repair or replacement of damaged items. Should the Contractor not repair or replace such damaged items, NJ TRANSIT will take corrective measures and deduct the cost from the Contract Price.

4.5.2 It shall be the responsibility of the Contractor at all times to protect construction excavations, trenches up to 10 feet from structures, and the structures from water damage, including damage by rainwater, ground water, backing up of drains, downspouts, or sewers. The Contractor shall construct and maintain necessary drainage and do pumping required to keep the Project free from water, and shall perform pumping necessary for the full and proper execution of the construction work and protection of the Project including equipment installed therein.

4.5.3 Beyond a point 10 feet from facilities, it shall be the responsibility of the Contractor to protect the trenches by shoring or other methods and perform pumping required to dispose of the surface and subsurface water to permit the satisfactory performance of the work. Each Contractor shall provide its own pumping equipment of adequate capacity and shall be responsible for fuel, cost of operators, and supervision.



4.5.4 The Contractor shall protect equipment, such as electric switch gear and HVAC equipment that is subject to damage by moisture during the period from installation of equipment to completion of the Project acceptance, and shall provide temporary waterproof enclosures and ceilings over such equipment. The interior of the enclosure shall be kept dry by whatever measures are necessary. Special openings shall be provided in the enclosures and ceilings in order to service the equipment during the protection period. The Contractor shall procure and maintain, during the protection period, insurance covering the subject equipment in the full amount of the value of the equipment. See Article 9.2- INSURANCE for submission of proof of carriage of insurance.

4.5.5 The Contractor shall remove snow and ice as may be required for the proper protection and prosecution of the Contract and to provide access to the Project Site.

4.5.6 In the event of temporary suspension of work, or during inclement weather, or whenever the Construction Manager shall direct, the Contractor shall protect, and shall cause its Subcontractors to protect, carefully its and their work and materials against damage from the weather. If, in the opinion of the Construction Manager or NJ TRANSIT, work or materials have been damaged, such work or materials shall be removed and replaced at the expense of the Contractor.

4.5.7 Unless otherwise specified or shown in the Contract Documents, the Contractor shall provide protection of the entire construction area. It shall also install four foot high snow fence around trees that are to remain and that are located within the Contract Limit Line, at a distance equal to the branch spread of the tree.

#### 4.6 PROTECTION OF PRIVATE PROPERTY

The Contractor shall not enter on or make use of private property in the prosecution of the Project unless written permission therefor is secured, in duplicate, from the owner of the property, one copy of which shall be filed with NJ TRANSIT. The Contractor shall promptly restore or repair, without cost to NJ TRANSIT and in a manner satisfactory to the owner of the property, property damaged or destroyed by its operations. Special attention shall be given to the protection of existing landscape features and natural vegetation.

#### 4.7 PROTECTION OF PUBLIC UTILITIES

4.7.1 The terms public utility or public utilities used in this Contract shall be construed to include those publicly and privately owned. Within the site of the Project there may be public utility facilities, and notwithstanding any other clause or clauses of this Contract, the Contractor shall not proceed with its work until it has made diligent inquiry at the offices of the Construction Manager, the utility companies and municipal authorities, NJ TRANSIT or other owners to determine their exact location. The Contractor shall notify, in writing, the utility companies and municipalities or other owners involved of the nature and scope of the Project and of its operations that may affect their facilities or property. Two copies of such notices shall be sent to the Construction Manager.

The Contractor's attention is called to the fact that the exact locations of the various overhead and underground lines, utilities, and structures located throughout the Project are unknown, and the Contractor is advised to use extreme caution during construction. The plans showing the approximate locations of the various overhead and underground lines, utilities, and structures are to be used only as guidelines and are not guaranteed as to their accuracy or correctness.

4.7.2 The Contractor shall carry out its work carefully and skillfully and shall support and secure public utility facilities so as to avoid damage to them. Flow in drains and sewers shall be satisfactorily maintained. The Contractor shall not move any public utility facilities without the owner's written consent and, upon the completion of the work, the condition of the facilities shall be as safe and permanent as before. When public utility facilities are damaged by the Contractor, it shall notify their owner, who shall cause the damage to be repaired at the Contractor's expense. If the cost thereof is not paid by the Contractor within thirty (30) calendar days after repairs have been completed, the Contracting Officer shall deduct an amount sufficient to cover the cost from any monies due or that may become due the Contractor under this Contract. Service connections damaged by the Contractor shall be repaired by competent skilled mechanics.

4.7.3 During the normal course of construction the Contractor may find it necessary to temporarily relocate certain public utilities in order to proceed. The Contractor will be responsible for the coordination and scheduling of all such relocations with the utility owner. If the Bid Item "Protection of Public Utilities" appears in the Bidder's Proposal, NJ TRANSIT shall reimburse the Contractor for these relocation services upon receipt of an itemized invoice from the participating utility owner, and only for the amount of the invoices, to be submitted along with the Contractor's monthly invoice. If the Bid Item "Protection of Public Utilities" does not appear in the Bidder's Proposal, the Contractor shall assume all costs associated with the temporary relocation of public utilities.

When facilities requiring relocation belong to NJ TRANSIT, the Contractor shall make requests for relocation by NJ TRANSIT personnel through the Construction Manager. The cost of such relocation shall be borne by NJ TRANSIT.

4.7.4 Under no circumstances shall the Contractor be entitled to damages of any kind arising from the need to relocate public utilities in order to complete the Work.

#### 4.8 PROTECTION OF EXISTING MONUMENTS

Existing monuments and title stones which need not be removed shall be left in place and protected by the Contractor against damage and dislocation. When relocation or change in the grade of existing monuments is necessary, they shall be protected in their original position until their removal is approved by NJ TRANSIT, and shall be reset when directed and in conformance with the new lines and grades to be furnished by the Contractor. Monuments and title stones that are to be left in place or reset and are moved without approval of NJ TRANSIT shall be replaced at the Contractor's expense.

4.9 MAINTENANCE AND PROTECTION OF ROADWAY AND PEDESTRIAN TRAFFIC

- 4.9.1 The Contractor shall conduct its work with the least possible obstruction of traffic. The convenience of the public and of the residents adjacent to the Project, and the protection of persons and property, are of primary importance and shall be provided for by the Contractor in an adequate and satisfactory manner. When a detour will be established, the Contractor shall make arrangements for establishing, maintaining, and signing for it and provide safety measures as are necessary to provide traffic guidance and protection. The signage shall include safety, directional and informational signals and devices necessary to provide effective pedestrian and vehicular circulation. The number and location of the signals and devices shall be subject to the Construction Manager's approval.
- 4.9.2 The Contractor shall erect or place, and maintain in good condition, appropriate and adequate barricades, signs, lights, beacons, flares, approved red flasher units, rubber cones, drums and other warning and danger signals and devices at working sites, closed roads, intersections, open excavations, locations of material storage, standing equipment and other obstructions; at points where the usable traffic width of the road is reduced; at points where traffic is deflected from its normal course of lanes; and at other places of danger to vehicular or pedestrian traffic or to completed work. Flagmen will be used as necessary. The various traffic control and warning devices shall be in accordance with Part VI of the Manual on Uniform Traffic Control Devices of the USDOT and approved by NJ TRANSIT's Construction Manager.
- 4.9.3 The Contractor shall provide, maintain and remove when no longer required, temporary driveways, parking areas and walkways that may be necessary to allow access to all parts of the Project, to adjacent property, and for handling of materials and equipment. Should the Contractor elect to place materials that will be incorporated into the permanent driveways, parking areas or walks, it shall not do so without having prepared the subgrade as may be elsewhere required by the Specifications nor will it be relieved from responsibility for providing additional materials or for reworking the subgrade, if required to make the improvements conform fully with the Specifications.
- 4.9.4 The Contractor shall obtain permission in writing from the Construction Manager before using existing driveways or parking areas for construction purposes. It shall maintain such driveways and areas in good condition during the construction period, and at the completion of the Project, shall leave them in the essentially equal or better condition as at the start of the work to the satisfaction of the Construction Manager.
- 4.9.5 The Contractor shall employ construction methods and means that will keep flying dust to the minimum. Trucks hauling materials shall have tight tail gates and shall be loaded with adequate freeboard of not less than three inches, without precarious cones or piles of material. It shall provide for the containment of dust on the Project, and on roads, streets and other areas immediately adjacent to the Project limits, wherever traffic or buildings that are occupied or in use are affected by such dust. The materials and methods used for dust control shall be subject to the approval of NJ TRANSIT.

- 4.9.6 When vehicular or pedestrian traffic, or both, is to be maintained on new or existing roadways and pedestrian paths of travel, the Contractor shall plan and carry out its work to provide for the convenient and safe passage of such traffic. The Contractor shall provide for prompt removal from such roadways and pedestrian paths of all dirt and other materials that have been spilled, washed, tracked or otherwise deposited thereon by its hauling or other operations. Roadways and pedestrian paths within the limits of the Project which are reserved for traffic shall be maintained by the Contractor free from obstructions and in a smooth traveling condition at all times.
- 4.9.7 The Contractor shall not perform construction work above vehicular or pedestrian traffic until it obtains explicit written permission from the Construction Manager. Subject to such permission, the Contractor shall provide the necessary devices and means to protect such traffic from falling construction materials and other objects and from painting operations, during the time that construction work is carried on above traffic.
- 4.9.8 The Contractor shall comply with local codes and ordinances affecting complete or partial roadway closings, detours and roadway and pedestrian protective measures. All costs associated with maintaining and protecting roadway and pedestrian traffic is at the Contractor's sole expense and is considered included in the Contract Price.
- 4.10 MAINTENANCE OF MARINE TRAFFIC
- Work over, on or adjacent to navigable waters shall be so conducted that free navigation of the waterways will not be interfered with and the existing navigable depths will not be impaired except as allowed by permit issued by the U.S. Coast Guard and/or the U.S. Army Corps of Engineers, as applicable.
- 4.11 MAINTENANCE OF RAILROAD TRAFFIC
- 4.11.1 Where the Project includes work across, over, under or adjacent to railroad tracks or railroad right-of-way as specified in the Contract Documents, the Contractor shall safeguard the traffic, tracks and appurtenances, and other railroad property affected by its work. It shall comply with the regulations of NJ TRANSIT Rail Operations and those of any other operating railroad company relating to the work; shall keep the tracks clear of obstructions; shall provide barricades, warning signs, lights, flares, and other danger signals and means of protection; and shall arrange with the operating railroad company through NJ TRANSIT for the furnishing of watchmen and flagmen and other protective service that may be required by the railroad company. The Contractor's work activities shall be conducted in strict conformance with the governing rules of the specific railroad on whose track it is working as detailed in Appendix D to these General Provisions. The Contractor shall note that work around and adjacent to the railroad is severely restricted during the annual holiday moratorium on performance of work, which is defined as the period beginning five (5) calendar days prior to Thanksgiving and ending on January 2 of the following year. Track outages and fouling may not be permitted during this period.

- 4.11.2 Work done within NJ TRANSIT railroad right-of-way shall be subject to the approval of NJ TRANSIT in matters affecting railroad property and the safety and operation of its trains. The safety and continuity of railroad operation shall be of primary importance and shall be at all times protected and safeguarded. The Contractor, and any Subcontractor, shall perform and arrange all pertaining construction work accordingly. Work shall be performed carefully and shall be regulated so as to avoid interruption of train movements and damage to the tracks and other facilities of the railroad. The Contractor agrees that delays in the performance of the Work attributable to the operations of the railroad shall not be the basis of claims for damages for delay or otherwise or for additional compensation. However, the Contractor may be entitled to an extension of time for completion of the Work, but only to the extent that the critical path of the work schedule is impacted by NJ TRANSIT railroad operations.
- 4.11.3 The maintenance and protection of railroad traffic will not be paid for under any specific scheduled item but the cost thereof, including the safeguarding of tracks, traffic and appurtenance of the railroad, watchmen, barricades, lights, signs, signals, warning, other protection and services is considered included in the Contract Price.
- 4.11.4 If work is done on or affecting the property of a railroad company other than NJ TRANSIT, the railroad company may assign inspectors or engineers during the time the Contractor is engaged in construction work on said railroad property for the general supervision of construction operations to insure adherence to Plans and Specifications and to insure the use of approved construction methods pertaining to the safety and condition of the company's right-of-way. The salary and expense of said inspector and/or engineers and the cost of other engineering services furnished by the railroad company will be at no cost to the Contractor, unless otherwise specified in the Special Provisions. The same care taken to protect NJ TRANSIT railroad traffic as set forth above shall be exercised in the protection of railroad traffic on other affected railroads.
- 4.11.5 Detailed Protective Measures
- A. General
1. Whenever in this Sub-article the term "Railroad" is used without further qualifications, it shall mean and be taken to mean NJ TRANSIT Rail Operations.
  2. The Contractor should note that the proposed work involves construction operations on and over property owned or controlled by the Railroad and will be performed adjacent to the high speed main line electrified tracks of the Railroad in the vicinity of high voltage lines of the Railroad. In working near these lines great care must be exercised and the Railroad's rules detailing requirements for clearance to be maintained between equipment and energized wires and other instructions in regard to working in the vicinity of their electric operations and requirements must be strictly observed whenever the tracks, structures, or properties of the Railroad are involved or affected.

3. Prior to commencement of work on Railroad property, the Contractor will name a qualified safety representative to interface with the Railroad's supervision. The Contractor safety representative will be responsible for ensuring full compliance with the Railroad's safety policies and procedures as they relate to the project. All Contractor personnel working within fouling distance shall attend the Railroad's safety orientation class which will be provided by the Railroad at no cost to Contractor. The Contractor's personnel may be required to travel to offices in Newark at One Penn Plaza East, or some other location convenient to the Railroad and remote from the site, for administration of this class. Each trained employee shall be issued a safety sticker to be placed on the employee's hard hat. The employee must display the sticker when working in the Railroad's limits. Contractor shall comply with the Railroad's safety requirements throughout the entire construction period. All costs encountered by Contractor due to complying with Railroad's safety requirements shall be at the sole expense of Contractor.
  4. If, during the carrying out of the Work, the tracks or other facilities of the Railroad are endangered, the Contractor shall immediately do such work as directed by the Railroad to restore safety, and upon failure of the Contractor to carry out such orders immediately, the Railroad may take whatever steps as are necessary to restore safe conditions. The cost and expense to the Railroad of restoring safe conditions or of any damage to the Railroad's trains, tracks or other facilities caused by the Contractor or Subcontractor's operations, shall be considered a charge against the Contractor and shall be paid for by the Contractor, or may be deducted from any monies due or that may become due to Contractor under this Contract. Final payment to Contractor shall be contingent upon a showing by the Contractor that the bills of the Railroad for such services have been paid by the Contractor.
- B. Rules and Regulations
1. Railroad traffic shall be maintained at all times with safety and continuity, and the Contractor shall conduct all of its operations on or over the Railroad's right-of-way fully within the rules, regulations, and requirements of the Railroad. The Contractor shall be responsible for acquainting itself with such requirements as the Railroad may demand. It is understood and agreed that the Contractor is cognizant of the limited ability of NJ TRANSIT to control the actions of the Railroad's operations and in its Bid has made allowance for the fact that no additional compensation will be allowed for any delays, inconvenience or damages sustained by Contractor due to the actions, operations, inactions, or interference of the Railroad.
  2. The Contractor shall obtain verification of the time and schedule of track occupancy from the Railroad before proceeding with any construction or demolition work over, under, within, or adjacent to the Railroad's right-of-way. The Contractor shall submit for the approval of the Railroad a detailed description of the method of procedure which will be followed for Work within these areas. The Work in the field shall not proceed until the plans and method of procedure have been approved by the Railroad.
  3. All work to be done under or over the Railroad's right-of-way shall be performed by the Contractor in a manner satisfactory to the Railroad and shall be performed at such times and in such manner

as not to interfere with the movement of trains or traffic upon the tracks of the Railroad. The Contractor shall use all necessary care and precaution in order to avoid accidents, damage, delay or interference with the Railroad's trains or other property.

4. The Contractor shall give written notice to NJ TRANSIT's Construction Manager and the Railroad at least thirty (30) calendar days prior to the commencement of any Work, or any portion of the Work, by the Contractor or its Subcontractors on, over or adjacent to the Railroad's right-of-way, in order to protect Railroad traffic.
5. If deemed necessary by the Railroad, it may furnish or assign an inspector who will be placed on the site of the Work during the time the Contractor or any Subcontractor is performing work under the Contract on Railroad property. The cost and expense will be paid directly by NJ TRANSIT.
6. Before proceeding with any construction or demolition work on, over or adjacent to the Railroad's property, a pre-construction meeting shall be held, at which time the Contractor shall submit for approval of the Railroad plans, computations, and a detailed description of Contractor's method of procedure for accomplishing the Work required under this Contract, including methods of protecting railroad traffic; however, such approval shall not serve in any way to relieve the Contractor of its complete responsibility for the adequacy and safety of its methods or procedures.
7. During the demolition procedures the Contractor must provide an approved shield to prohibit all debris from falling onto Railroad's right-of-way. The shield must be designed to provide a solid barrier between the work area and the tracks below. This shield must span over all tracks plus an additional 15 feet beyond the center line of each track. The Contractor is to submit details and calculations of the proposed shield for Railroad approval.
8. Whenever equipment or personnel are working closer than fifteen (15) feet from the nearest rail or eighteen (18) feet from the center line of track or over the top of track within this limitation, that track shall be considered fouled. Cranes, shovels, or any other equipment shall be considered to be fouling the track when located in such position that failure of same, with or without load, brings the equipment within the fouling limit. Operations within this fouling distance shall be conducted only with the permission of the Railroad and as directed by qualified railroad employees providing protection for track, signal, and catenary equipment. A power line is fouled and subject to hazard when any object is brought to a point less than ten (10) feet therefrom and a signal line or communication line shall be considered fouled and subject to hazard when any object is brought nearer than eight feet to any wire or cable.
9. The Contractor shall conduct its Work and handle its equipment and materials so that no part of any equipment shall foul an operated track or wire line without the written permission of the Railroad and NJ TRANSIT's Construction Manager. When the Contractor desires to foul an operated track, it must give the Railroad and NJ TRANSIT's Construction Manager written notice of its intentions thirty (30) calendar days in advance, so that if approved, arrangements may be made for proper protection of the Railroad. Although the Railroad may shift or reroute traffic to accommodate Contractor, flagging protection shall still be provided when fouling a normal operating track as this track could be returned to operation on short notice as necessitated by

demand. Contractor shall conform to working hours as determined by the Railroad with regard to fouled tracks and/or platform work. If railroad flagmen or protection is not available, construction work shall not be undertaken if this Work is to take place within the fouling limits. Should Contractor violate any of the conditions set forth herein, Railroad shall have the right to remedy the situation as appropriate, including suspending the Work, at the sole cost and expense of Contractor. The Contractor's employees and equipment will not be permitted to work near overhead wires or apparatus, except when protected by a Class A employee of the Railroad who will take necessary precautions for their safety before starting and during the progress of such Work. The Contractor must supply and install a grounding cable (4/0 copper or equivalent ACSR) for each piece of equipment working adjacent to any electrified lines. The ground must be an approved 'C' clamp type ground. When Contractor is working in existing electrified territory, it shall comply with the High Voltage Proximity Act, N.J.S.A. 34:6-47 et seq.

10. Equipment of the Contractor to be used adjacent to the tracks shall be in first-class condition so as to fully prevent failures of defective equipment that might cause delay in the operation of trains or damage to Railroad facilities. The Contractor's equipment shall not be placed or put into operation adjacent to tracks without first obtaining permission from the Railroad and NJ TRANSIT's Construction Manager. Under no circumstances shall any equipment or materials be placed or stored within eighteen (18) feet from the near rail of a track in operation.
11. Materials and equipment belonging to the Contractor shall not be stored on Railroad property without first having obtained permission from the Railroad NJ TRANSIT's Construction Manager and such permission will be on the condition that the Railroad and NJ TRANSIT will not be liable for damage to such materials and equipment from any cause. The Contractor shall keep tracks adjacent to the site clear of all refuse and debris that may accumulate from its operations, and shall leave the Railroad property in the condition existing before the start of its operations.
12. The Contractor shall consult the Railroad and NJ TRANSIT's Construction Manager in order to determine the type of protection required to insure safety and continuity of Railroad traffic incident to the particular methods of operation and equipment to be used on the Work. Any B & B Inspectors, track foremen or track watchmen, signalmen, electric traction linemen, or other employees deemed necessary for protective services by the Railroad, or its duly authorized representative, to insure the safety of trains, contingent upon the Contractor's operations, shall be obtained from the Railroad by the Contractor. The Contractor shall make all such requests through NJ TRANSIT's Construction Manager. The cost of same shall be paid by NJ TRANSIT.
13. The providing of such watchmen and other precautionary measures shall not, however, relieve the Contractor from liability for payment of damages caused by its operations.
14. The Railroad will require flagging and/or other protection of railroad traffic during all periods when the Contractor is working on or over the right-of-way of the Railroad, or as may be found necessary in the opinion of the Railroad Engineers. When protection is required the Contractor shall make the requests in writing to NJ TRANSIT's Construction Manager, who will forward same to the Railroad at least thirty (30) calendar days before such protection is required. NJ TRANSIT



shall be responsible for any compensation owing to the Railroad for such protection. Contractor shall not include the cost of such railroad protective services in its Bid. However, the costs for safeguarding the tracks, barricades, lights, signs, signals warnings, other protections and services, including insurance shall be provided by the Contractor and shall be included in the Bid price.

15. Prior to the beginning of Work, it must be determined whether the tracks near the work area must be taken out of service. The track must be taken out of service by a qualified Railroad employee when any of the following conditions exist:
  - a. Any construction machinery or equipment occupies the traffic envelope or is standing within 18 feet of the center line of an outside track.
  - b. Any unsecured construction materials are stored within 20 feet of the center line of any track.
  - c. Excavations will be performed under operating tracks or adjacent to where stability of tracks may be affected. Under no circumstances will excavations be permitted within the "track live load influence line". The live load influence occurs when an excavation nearest the adjacent track intersects a line from a point five feet horizontally from center line of adjacent track at the plane of the base or rail drawn on a slope of 1-1/2 foot horizontal to one foot vertical. If the excavation occurs within this perimeter, then temporary earth support plans, designed and sealed by a registered professional engineer, shall be submitted for approval. In any event, the excavation shall be no less than 25 feet from adjacent track, unless otherwise approved by the Railroad. Excavations shall be fenced, lighted, and otherwise protected as directed by the Railroad.
  - d. Any other conditions, circumstances, or situation that may present a danger to the safe movement of trains.
16. It shall be expressly understood that this Contract includes no work for which the Railroad is to be billed by the Contractor, and it shall be further understood that the Contractor is not to bill the Railroad for any work which the Contractor may perform.
17. Upon completion of the work and as a condition of Final Acceptance, the Contractor shall remove from within the limits of the Railroad's right-of-way, all machinery, equipment, surplus materials, false work, rubbish and temporary buildings and other property of the Contractor, or Subcontractor, and shall leave the right-of-way in a condition satisfactory to the Railroad and NJ TRANSIT's Construction Manager.
18. Contractor notices for assignment of Railroad personnel and other written requests shall be directed to the Railroad through NJ TRANSIT's Construction Manager.
19. Crossing of tracks at-grade by equipment and personnel is prohibited except by prior arrangement with the Railroad.
20. All tunneling, jacking and boring operations within the railroad track influence lines shall be performed on a 24 hour/day basis to minimize the Railroad's exposure to construction hazards.
21. No Work across, over, under or adjacent to the Railroad shall commence until the Contractor's written notice is received and approved by the Railroad and all required personnel have attended

the Railroad's safety class. Thereafter, rail protective personnel will be assigned, as required, for the Work.

4.12 WORK FURNISHED BY OTHERS

4.12.1 NJ TRANSIT may, and reserves the right to, enter upon the work site, or areas adjacent thereto, at any and all times during the progress of the work, or cause others to do so, for the purpose of performing work not included in these Contract Documents.

4.12.2 When such additional work is to be performed, the Contractor shall conduct its work so as not to interfere with or hinder the progress or completion of the work being performed by others. Moreover, the Contractor assumes the positive obligation of cooperating with such others and coordinating its activities with theirs. If there is a difference of opinion as to the respective rights of the Contractor and others doing work within the limits of or adjacent to the Project, NJ TRANSIT will decide as to the respective rights of the various parties involved in order to secure the completion of NJ TRANSIT's work in general harmony and in a satisfactory manner. NJ TRANSIT's decision shall be final and binding on, and shall not be cause for claims by the Contractor for additional compensation.

4.12.3 The Contractor shall assume all liability, financial or otherwise, in connection with this Contract and hereby waives any and all claims against NJ TRANSIT for additional compensation that may arise because of inconvenience, delay, or loss experienced by the Contractor because of the presence and operations of others working within the limits of or adjacent to the Project.

4.12.4 The Contractor will not be held responsible for damage or loss to work performed on the Contract or on other contracts within or adjacent to the site of the Project that may be caused by or on account of the work of others. The Contractor will be held responsible for any damage or loss done or caused by its work or forces to the work performed by other contractors within or adjacent to the site of the Project and it shall repair or make good any such damage or loss in a manner satisfactory and without cost to NJ TRANSIT.

4.12.5 The Contractor shall examine work or materials not included in this Contract, the installation of which will affect the work in this Contract, and should the same be imperfect, incorrect or insecure, it shall notify the Construction Manager immediately in order that the same may be rectified. The Contractor shall arrange its work and shall place and dispose of the materials being used so as not to interfere with the operation of others within the limits of the Project or adjacent thereto. The Contractor shall join its work with that of the others in an acceptable manner and shall perform it in proper sequence to that of the others.

4.13 ARTS IN TRANSIT

4.13.1 Art is included in NJ TRANSIT's capital program to enhance the appearance of NJ TRANSIT's buildings and infrastructure. As such, this Contract may incorporate art as designated by NJ TRANSIT.

NJ TRANSIT will be responsible for the selection of the Artist(s) and the Contractor shall enter into and abide by the Artist Agreement contained in Appendix E, Agreement between Contractor and Artist. The Contractor shall place no other contract requirements or conditions upon the Artist(s). The Contractor shall submit a copy of the executed agreement to the Construction Manager within fifteen (15) calendar days after its execution. NJ TRANSIT retains the right to direct the Contractor to amend the Artist Agreement under the terms of Article 3.1, Change Orders.

4.13.2 The Contractor shall prosecute its Work so that installation of Artwork shall proceed in the manner and within the scheduled times directed by NJ TRANSIT and as incorporated in the Artist Agreement. The installation of the Artwork shall be included in the Contractor's Construction Progress Schedule.

Should the subject Artwork not be deemed substantially complete by NJ TRANSIT within the specified time allotted in the Artist Agreement, except for causes beyond the Contractor's and Artist's control, NJ TRANSIT may deduct from the amount due the Contractor \$100.00 per calendar day of delay as Artwork Liquidated Damages. The Artwork Liquidated Damages are to be separate from the Contract liquidated damages set forth in Article 2.1, TIME OF COMPLETION, DELAY, LIQUIDATED DAMAGES.

The Contractor shall not be charged with the Contract liquidated damages when the delay in substantial completion of the Work is solely due to late completion of the Artwork, unless the delay is attributable to acts or omissions of the Contractor. In that event, only the Artwork Liquidated Damages shall apply.

4.13.3 Upon completion and installation of the Artwork, NJ TRANSIT shall inspect the Artwork and installation and shall either accept or reject the Artwork. Upon NJ TRANSIT's acceptance of the Project and as part of the Contract close-out process, the Contractor shall assign the Agreement with the Artist(s) and all rights to the Artwork to NJ TRANSIT.

4.13.4 Payment for the above work and services shall be made from the Allowance identified in the Bidder's Proposal under the Item entitled: "Artwork Allowance". The Contractor shall pay the Artist in accordance with Attachment A, "Fees, Material and Payment Schedule" in the Artist Agreement. The Contractor is entitled to a markup of 5% overhead and 5% profit on the Artist's contract amount identified in the Artist Agreement as "Attachment D".

## **5. MOBILIZATION AND TEMPORARY FACILITIES**

### **5.1 MOBILIZATION**

5.1.1 When the item Mobilization and General Requirements (Mobilization) is included as a Contract Item it shall consist of initiating the Contract, and shall include such portions of the following as are required at the beginning of the Project: setting up the Contractor's general plant, offices, shops, storage areas, sanitary and other facilities as required by the Specifications, by Federal, State, or local law or by regulation; providing access to the Project site; obtaining necessary permits, grants and licenses, and payment of fees;

protecting existing utilities; lighting work areas; providing shop drawings; sampling and testing of materials; providing required insurance and bonds other than the Performance Bond and Payment Bond, unless Insurance Bid Items are included in the Bidder's Proposal. Mobilization shall also be deemed to include the Contractor's cost of ongoing maintenance and protection of the work premises, demobilization and remobilization as necessary to accommodate sequencing the work, and all costs associated with the provision and maintenance of temporary facilities, unless a specific Bid Item has been provided in the Bidder's Proposal for a specific element of work (e.g. Field Offices).

5.1.2 Payment for Mobilization as hereinbefore specified will be made for the lump sum price bid therefor, regardless of the fact that the Contractor may have, for any reason, shut down its work on the Project or moved equipment away from the Project and back again.

5.1.3 Except where a specific Bid Item has been provided in the Bidder's Proposal for a specific element of work, the provisions for payment of the Contract Item Mobilization supersede any provisions elsewhere in the Contract for including the costs of these initial and ongoing services and facilities in the prices bid for the various Contract Items in the Proposal.

5.1.4 Payment to the Contractor for the item Mobilization will be made in accordance with the following schedule:

- (a) When five (5) percent of the work is completed – twenty-five (25) percent of the amount bid for mobilization or two and one half (2 1/2) percent of the total Contract Price, whichever is less, will be paid.
- (b) When ten (10) percent of the work is completed an additional twenty-five (25) percent of the amount bid for mobilization or five (5) percent of the total Contract Price, whichever is less, will be paid.
- (c) When twenty-five (25) percent of the work is completed an additional twenty-five (25) percent of the amount bid for mobilization or six (6) percent of the total Contract Price, whichever is less, will be paid.
- (d) When fifty (50) percent of the work is completed – an additional twenty-five (25) percent of the amount bid for mobilization or ten (10) percent of the total Contract Price, whichever is less, will be paid.
- (e) The percentage of work completed shall be the total of payments earned, exclusive of the amount paid for this item, as shown on the monthly certificates of the approximate quantities of work done.
- (f) Upon completion of all work on the Project, payment for any amount bid for mobilization in excess of ten (10) percent of the total Contract Price will be paid.

5.1.5 When the item Mobilization is not a Contract Item, no specific payment will be made for the work included in this Article. All costs thereof shall be included in the prices bid for the various scheduled Contract Items.

5.2 FIELD OFFICE AND SANITARY FACILITIES

5.2.1 The Contractor shall provide a field office on or as convenient to the job site as possible, subject to the approval of the Construction Manager and sufficient to accommodate NJ TRANSIT representatives assigned to the Project. Such space, together with necessary furnishings, equipment, supplies, etc., and all utilities shall be as required by this Article.

5.2.2 Within thirty (30) calendar days of the Notice to Proceed, the Contractor shall provide and maintain the mobile trailer units described herein with parking facilities for five vehicles. The Field Office and the parking facilities will be for the use of the Construction Manager, Engineer/Architect, and their staff.

5.2.3 The Field Office shall be a new or like new NJDCA approved weatherproof mobile trailer with a 7-foot minimum ceiling height, weatherproof windows (screened), doors each equipped with adequate locking devices, and a burglar and fire alarm system to be connected to a local 24-hour security service. The Field Office shall total at least 576 square feet and shall be divided into three rooms, one with a floor area of not less than 288 square feet and two with floor areas of not less than 144 square feet. All walls shall be paneled. The Field Office location shall be approved by the Construction Manager. The trailer shall be adequately tied down to resist high winds. The Contractor shall level the Field Office trailer and provide entrance steps, landing platforms, handrails, and under trailer enclosures as directed by the Construction Manager. The Contractor shall obtain required DCA permits and approvals for the Field Office as well as any subsequent permit renewals.

5.2.4 All Field Office windows are to be protected by expanded metal grilles with angle frames which are to be through bolted top 2" x 2" x 1/4" plates. All external doors are to be heavy duty construction with cylinder locks and with two 2" x 2" x 1/4" angle bars which can be placed across the closed door and padlocked in place. Padlocks to be placed through eye bolts which are to be through-bolted to 2" x 2" x 1/4" plates. Contractor shall supply the padlocks and all keys (original and copies) to the Construction Manager.

5.2.5 The Contractor shall maintain and service the Field Office trailer as specified in this Article. Upon project completion, and only after receipt of written authorization from the Construction Manager, the Contractor shall remove the Field Office from the job site.

5.2.6 Any relocation of the Field Office trailer and utilities during the entire project duration shall be the Contractor's responsibility.

5.2.7 The Contractor shall provision the Field Office as follows:

1. Provide adequate lighting, electrical receptacles, and ground fault circuit interruptions as required by OSHA.
2. Provide lighting to furnish a minimum of 100 foot-candles at desk height uniformly in all areas.

3. Provide heating and cooling equipment and any necessary fuel to maintain an ambient air temperature of 70 degrees F +/- 5 degrees F.
4. Provide and maintain a source of hot and cold potable water for use in a flushing water closet, and for hand washing. The Contractor shall be responsible for plumbing hook-up to a sanitary line or for provision of a storage tank.
5. Provide five separate phone lines; three lines to be equipped for voice; one for fax and one with modem capabilities. Provide and install the phone system with three new touch-tone phones with answering machine, speaker and hunting capabilities. All equipment shall be approved by the Construction Manager prior to installation.
6. Provide OSHA required fire extinguisher.
7. Furnish the CM Field Office with the following new equipment and furniture as approved by the Construction Manager:

<b>Table 5.2.7.7: Field Office Equipment</b>	
Description	Quantity
Desk (60" x 30") with three lockable draws and rolling armchair	3
Drafting table (60" x 36") with drawer and 54" straightedge and stool	1
Reference table (54" x 30")	1
Conference table (36" x 96")	1
Metal folding chairs with saddle seat and steel back	10
Storage cabinet (36" x 18" x 6") with lock and two keys	1
Two file cabinets, four (4) drawers (legal size) with lock and key.	2
Two file cabinets, fireproof, four (4) drawers (legal size) with lock and key.	2
Greensteel marker board (36" x 48"), mounted, and supply of markers including replacements as required	1
Copier, using 8-1/2" x 11", 8-1/2" x 14", and 11" x 17" paper	1
Two cubic feet refrigerator/freezer	1
Wall clock (battery operated) 12" diameter face	1
Plain paper laser and facsimile machine capable of 8½ x 11 and 8½ x 14" paper	1
Automatic Drip Coffee machine (10 cup)	1
Fully stocked first-aid cabinet in compliance with OSHA regulations	1
Microwave	1
Bookcase (36 x 42) with four shelves	1

5.2.8 The Contractor shall maintain and service the Field Office in accordance with the following requirements. The Contractor shall:

1. Repair and clean the Field Office, including complete janitorial services, including cleaning and emptying of any temporary sanitary system, and trash removal, at a minimum frequency of once per week to the level approved by the Construction Manager.
2. Repair, clean, and adjust equipment specified under Sub-article 5.2.7 and provide repair/maintenance service with 24 hour response/repair time for proper operation of all copiers,

typewriters, computers, and any other office equipment whether supplied by the Contractor or supplied by others.

3. During other than normal working hours, provide security measures and area protection adequate to insure the safety and integrity of the project site.
4. Provide all necessary paper, including sanitary paper, and other office supplies as required by the Construction Manager.
5. Provide adequate bottled water and paper cups inside the Field Office.
6. Provide coffee, filters, plastic stirrers, sugar, cups, napkins, and non-dairy creamer.
7. Maintain and restock the first-aid cabinet as required.

5.2.9 Payment for the Field Office materials and services identified in this Article shall be as follows:

- A. Included and to be paid for under the Bid Item "Mobilization and General Requirements" shall be the costs for the following:
  1. Trailer site preparation and trailer delivery.
  2. Trailer utility and sanitary hookups.
  3. Trailer set-up, including: skirting, tying down, securing and making the trailer weatherproof; wooden stair and platform construction (including handrails); installation of burglar alarm system; and other miscellaneous efforts required to provide safe and orderly access to the trailer. Further, any and all labor and materials required for repair and maintenance to the above for the duration of the project.
  4. Obtaining and paying for any and all permits required for hauling, building and making utility connections for the trailer.
  5. Any costs associated with the location and/or relocation, for any reason, of the Field Office and utilities.
  6. All Field Office equipment and furnishings identified in this Article.
  7. Trailer demobilization and removal at the completion of the project, including utility disconnections, temporary construction and disposal fees.
  8. Any and all other costs associated with mobilizing, erecting, maintaining, repairing, demobilizing and removing the Field Office trailer and associated temporary improvements/structures.
  9. All costs associated with Sub-article 5.2.8 Items 1, 2 and 3.
- B. Included and to be paid for under the Bid Item Allowance "Field Office" shall be the costs for the following:
  1. Monthly rental of the Field Office trailer.
  2. NJ TRANSIT telephone usage.
  3. NJ TRANSIT electrical power usage.
  4. NJ TRANSIT heating fuel expenses.
  5. Office supply account covering all costs associated with Sub-article 5.2.8 Items 4, 5, 6 and 7.

The Contractor shall submit copies of invoices from the trailer rental and utility companies and receipts for office supply expenses along with the monthly applications for payment. The Contractor shall be reimbursed for the items listed in this Sub-article 5.2.9.B as a direct expense without any additional markups for overhead or profit.

All items purchased by the Contractor under Article 5.2 shall become the property of the Contractor for his use or disposition upon removal of the Field Office.

### 5.3 CONSTRUCTION SIGN

The Contractor shall construct and install construction sign(s) as indicated in the Contract Documents. Lettering shall be as shown in the Contract Documents and shall include the names of the Contractors engaged on the Project and such other persons or entities as directed. The sign(s) shall be securely installed to remain rigid and plumb, shall be maintained in good condition throughout the construction period, and shall be removed when directed by the Construction Manager. If the Contractor desires to install a sign other than those specified in the Contract Documents it shall first obtain the approval of the Construction Manager.

### 5.4 TEMPORARY WATER

5.4.1 The Contractor shall provide, protect and maintain an adequate water supply for use on the Project during the period of construction, either by means of the permanent water supply line, or by the installation of a temporary water supply line. This water supply line shall be made available within fifteen (15) calendar days after written authorization to proceed with the Project. If the source of water supply is a well, provisions covering the supply of water will include the installation of necessary power driven pumping facilities by the Contractor, as well as protection of well from contamination. The water supply shall be tested periodically by the Contractor and, if necessary, shall be chlorinated and filtered.

5.4.2 The Contractor will be required to install a valved temporary water supply connection at a point approximately 10 feet from the building or buildings and provide a meter, if required; the actual location of the point to which the water is brought shall be determined by the Contractor.

5.4.3 If there is a charge for water, said charges shall be paid by the Contractor. When temporary water lines are no longer required they shall be removed by the Contractor and any part, or parts, of the grounds or building disturbed or damaged shall be restored to the original condition by the Contractor. The Contractor shall install its permanent water lines to the boiler room and heating equipment in sufficient time to be available for supplying water for testing and operation of the heating system when needed to supply heat on the Project.



5.5 TEMPORARY LIGHT AND POWER

5.5.1 The Contractor shall extend electrical service to the building or buildings at locations approved by the Construction Manager; temporary electrical service shall be independent of the existing permanent service. Initial temporary service shall be three phase or single phase depending upon which phase is nearest to the Project site. This service shall be installed within fifteen (15) calendar days after written Notice to Proceed with the Project. When the Contract calls for three phase permanent service, the Contractor shall install same within a reasonable time to permit use by all the trades.

5.5.2 The Contractor shall extend the service into the building and shall provide such receptacles and lighting as required for the proper conduct of the work.

5.5.3 The Contractor shall pay for cost of all electric energy used, and it shall also maintain and service any electrical equipment installed and necessary for maintaining heat after same is required in the building.

5.5.4 When the temporary electrical lines are no longer required they shall be removed by the Contractor and it shall restore to their original condition any part, or parts, of the grounds or building disturbed or damaged.

5.5.5 Any Contractor who fails to carry out its responsibility in the supplying of uninterrupted light and power to expedite the Project, as set forth in this Contract, shall be held responsible for such failure and the Contracting Officer shall have the right to take such action as the Contracting Officer deems proper for the protection and conduct of the work and shall deduct the costs involved from the amount due the Contractor.

5.6 TEMPORARY HEAT

5.6.1 The Contractor shall provide, protect and maintain, at its own expense, sufficient heat to the Project during the entire period of construction either by using an NJ TRANSIT approved method of temporary heat or, when operational, the permanent heating system.

5.6.2 Prior to any building being enclosed by walls and roof, if the outside temperature shall fall below 40 degrees F., at any time during the day or night, and the work in progress requires heat for execution and protection, the Contractor shall furnish acceptable means to provide sufficient heat to maintain a temperature of 40 degrees F., for that portion of the work which requires same.

5.6.3 Heating of field office, storage spaces, concrete and masonry materials and working area heating required prior to enclosure, as specified herein, shall be provided by the Contractor as specified in the Contract Documents.

5.6.4 As soon as the building, or a major unit thereof, is generally enclosed by walls and roof, as determined by the Construction Manager, the responsibility for supplying working area heat shall rest with the Contractor. When the outside temperature falls below 40 degrees F., at any time during the day or night, the Contractor

shall furnish sufficient heat, by the use and maintenance of LP gas heaters or other system approved by the Construction Manager, to maintain a temperature of 45 degrees F. within the enclosed area of the building at all times and shall remove same when no longer required. The Contractor shall provide or arrange at its own expense supervision of the LP gas heaters at all times prior to start of the permanent heating system. The Contractor shall furnish and pay for all fuel required for the above temporary installation during the term of this contract.

- 5.6.5 The Contractor will be held responsible for freeze ups following enclosure of the building. The Contractor shall remove soot, smudges, and other deposits from walls, ceilings, and exposed surfaces which are the result of the use of heating equipment including the permanent heating system during the period of its use for supplying heat. The Contractor shall not do any finish work until the areas are properly cleaned.
- 5.6.6 A building, or major unit thereof, shall be considered "enclosed" when: (1) the exterior walls have been erected; (2) temporary roof or permanent roof is installed and in watertight condition; and (3) temporary or permanent doors are hung and window openings are closed with either permanent or temporary weather tight enclosures (cardboard, muslin and light canvas materials are not acceptable; any impervious transparent material is acceptable). A major unit of building as referred to herein shall be: (1) an entire separate structure; (2) a fully enclosed wing which shall have a floor area equal to at least 50 percent of the total floor area of the Project; or (3) a section which shall have a floor area equal to at least 50 percent of the total floor area of the Project.
- 5.6.7 Sixty (60) calendar days after the building, or major unit thereof, is enclosed and the Engineer has determined that heat is required for the proper execution of the construction work, the permanent heating system shall provide the heat. Regardless of whether the boiler room is within the confines of the major unit or not, it shall be enclosed and the floor installed at the time the permanent heating system shall supply heat. The boiler room floor area shall not be considered in determining the area comprising the major unit. The 60 day period shall apply only to the enclosed portion of this building.
- 5.6.8 The Contractor shall continue to provide acceptable means of temporary heat until the permanent heating system is operational. If the permanent heating system is not acceptable to the Construction Manager for providing sufficient heat, the Contractor shall continue to provide temporary heat as described above and as ordered by the Construction Manager or NJ TRANSIT.
- 5.6.9 When the heating system provided by the Contractor is designed for tie-in to existing steam lines for source of heat, NJ TRANSIT will provide steam for temporary heat through the Project's permanent heating system at no additional cost to the Contractor. The Contractor shall arrange, at its own cost, for connections.
- 5.6.10 Valves, traps and other parts of the heating system which are permanently installed by the Contractor and used for supplying heat during the construction period need not be replaced, provided the system was in acceptable condition prior to its use, and further, that the system is properly cleaned and adjusted to

operate after the permanent system is in use to the satisfaction of the Construction Manager. Seven (7) calendar days prior to acceptance by NJ TRANSIT of the heating system as substantially complete, the Contractor shall replace disposable filters or turn over spare sets of filters to NJ TRANSIT.

## 5.7 TEMPORARY PARTITIONS, ENCLOSURES, GLAZING BREAKAGE AND CLEANING

5.7.1 Whenever necessary, in order to maintain proper temperatures for the prosecution of the work, or for the protection thereof, the Contractor shall furnish and maintain temporary enclosures and partitions. All openings in exterior walls not enclosed with finishing materials shall be closed temporarily. Window sashes may be installed and glazed. Temporary wood doors shall be provided at door openings. Temporary partitions shall be securely anchored, stable, well-constructed and maintained, and fit for the purpose intended, e.g., work area separation, protection of the public, delineation of pedestrian pathways, etc.

5.7.2 The Contractor shall be responsible for all breakage of glazing after same has been installed, no matter by whom or what caused, and shall replace all broken, scratched or otherwise damaged glazing before the completion and acceptance of the work. The Contractor shall wash all glazing on both sides at completion, or when directed, removing all paint spots, stains, plaster, etc.

5.7.3 The Contractor shall provide and maintain necessary temporary dustproof partitions around areas of work in any existing building.

## 5.8 TEMPORARY, INTERMEDIATE AND HIDDEN WORK

5.8.1 The Contractor shall be responsible for temporary, intermediate and hidden work, including the furnishing and setting of sleeves, built in items, anchors, inserts, and chases for its work. The Contractor shall build these items into the construction. The Contractor shall build recesses, channels, chases, openings, and flues, and leave or create holes where shown on Drawings or where directed for steam, water or other piping, electrical conduits, switch boxes, panel boards, flues and ducts, or other features of the heating and ventilating work. Subcontractors requiring such recesses, channels, chases, openings, and flues shall furnish to the Contractor complete details and drawings of such as required in connection with the work. Such information shall be furnished in complete form and in ample time to allow the construction work to proceed without interruption or delay. These details and drawings shall be furnished in accordance with Article 6.5- SHOP AND WORKING DRAWING SUBMITTALS to the Construction Manager for review and approval prior to installation.

5.8.2 The Contractor shall close, build in, and finish around or over openings, chases, channels, pockets, and sleeves after installation has been completed.

5.8.3 Positive instructions in writing shall be obtained from the Engineer before cutting or boring floor beams, floor constructions, or supporting members.

5.9 DEMOBILIZATION

At the completion of the Work and prior to final payment, the Contractor shall remove temporary facilities entirely from the site including, but not limited to the following: Field offices, trailers, shanties, sheds, temporary electric services, temporary water hydrants, temporary fences, project sign, job telephone, temporary roads, temporary toilets, temporary enclosures, dust barriers, and other temporary protection devices. The Contractor shall conduct final cleaning activities and restore all disturbed landscaping, street and sidewalk surfaces, subsurfaces and overhead structures, if any. Should the Contractor fail to remove such temporary facilities and restore disturbed conditions, NJ TRANSIT shall perform such activities as necessary and deduct the cost from the Contractor's final payment.

**6. PROJECT ADMINISTRATION AND DOCUMENT CONTROL**

6.1 PROJECT MEETINGS

6.1.1 The Contractor, Subcontractor, supplier or vendor whose presence is necessary, unless excused in writing by the Construction Manager, shall attend project meetings when called by the Construction Manager for the purpose of discussing the execution of the Work. The initial pre-construction meeting will generally be held prior to commencement of the work at a time, date and location to be set by the Contracting Officer.

6.1.2 General Requirements for Project Meetings:

- A. One of the persons designated by the Contractor to attend and participate in the project meetings shall have all required authority to commit the Contractor to solutions agreed upon in the project meetings.
- B. To the maximum extent practicable, advise the Construction Manager at least 24 hours in advance of project meetings regarding all items to be added to the agenda.
- C. The Construction Manager will compile the official minutes of each project meeting and will furnish three (3) copies to the Contractor.
- D. Except as noted below for the Pre-Construction Meeting, Project Meetings will be held once every two weeks. The Contractor and Construction Manager shall coordinate as necessary to establish a mutually acceptable schedule for meetings.

6.1.3 Pre-Construction Meeting:

- A. A pre-construction meeting will be scheduled by NJ TRANSIT. The Contractor shall provide attendance by an authorized representative and authorized representatives of all major Subcontractors. The Construction Manager will advise other interested parties and request their attendance. The Construction Manager and the Contractor will arrange to review details of construction, and if appropriate, to walk the project with the Contract Drawings in hand and carefully observe all pertinent conditions relating to the construction of the Work, including the status of right-of-way, existing structures and obstructions to be removed, altered or changed.

- B. Minimum Pre-Construction Agenda: The Contractor shall be prepared to discuss:
- (1) Organizational arrangement of Contractor's forces and personnel, and those of Subcontractors, materials suppliers, Engineer and Construction Manager.
  - (2) Established channels and procedures for communications as approved by NJ TRANSIT.
  - (3) Construction schedule, including sequence of critical work as described in Article 6.2- CONSTRUCTION PROJECT SCHEDULE.
  - (4) Contract Documents, including distribution of required copies of original documents and revisions.
  - (5) Processing of shop drawings and other data submitted to the Construction Manager for review.
  - (6) Processing of field decisions and contract change orders.
  - (7) Rules and regulations governing performance of the Work.
  - (8) Procedures for safety and first aid, security, quality control, housekeeping, and other related matters.
  - (9) Existing conditions.
  - (10) Equal employment regulations.
  - (11) DBE requirements.
  - (12) Quality assurance.
  - (13) MSDS submittal requirements as set forth in Article 9.7- ENVIRONMENTAL COMPLIANCE AND LIABILITY.
  - (14) Subcontractor submittals and approvals as set forth in Article 1.9- ASSIGNING AND SUBCONTRACTING CONTRACT. The Contractor shall provide the initial submittals noted therein.
  - (15) Contract Completion and liquidated damages.

6.1.4 Project Meetings:

- A. Attendance: To the maximum extent practicable, assign the same person or persons to represent the Contractor and major Subcontractors, as requested by NJ TRANSIT, at project meetings throughout progress of the Work. If requested by NJ TRANSIT, Subcontractors, material suppliers, and others shall attend those project meetings in which their aspects of the Work are involved.
- B. Minimum Agenda for Project Meetings:
- (1) Review, revise as necessary, and approve minutes of previous meeting.
  - (2) Questions and issues unresolved at the previous Project Meeting.
  - (3) Engineer's, Construction Manager's and/or Contractor's unsatisfied request for information.
  - (4) Work accomplished since the previous Project Meeting, off-site fabrication problems, product delivery problems, proposed changes, and other circumstances which might delay progress of the Work.

- (5) Corrective measures and procedures developed to regain planned and scheduled progress.
- (6) Field observations, problems, Engineer's or Construction Manager's decisions, work quality, and employee work standards.
- (7) Plan of the following month's Work.
- (8) Status of DBE Subcontractors.
- (9) NPC and Change Order statuses.
- (10) CPM status.
- (11) Submittal schedule.
- (12) Safety.
- (13) Others, as required.

## 6.2 CONSTRUCTION PROJECT SCHEDULE

6.2.1 The Contractor shall be responsible for preparing and furnishing, at the pre-construction meeting, an initial draft of a coordinated combined project schedule that incorporates the project schedules of the Contractor and its Subcontractors activities for the prosecution of the work. The schedule shall be a CPM (Critical Path Method) schedule in sufficient detail satisfactory to the Construction Manager.

6.2.2 Float, or slack time, in the schedule is defined as the amount of time between the early start date and late start date or the early finish and late finish date of any activity. The definition of float or slack time also includes the amount of time between the late finish date of the Contractor's schedule and the time for completion specified in the Contract Documents, if the Contractor's scheduled late finish date is earlier than the Contract Time. Float or slack time is not for the exclusive use or benefit of either the Contractor or NJ TRANSIT, but for the overall benefit of the project as determined by NJ TRANSIT. Extensions of time for performance under any and all of the provisions of this Contract will be granted only to the extent that such equitable time adjustments for the activity or activities affected exceed the total float along the paths involved at the time the delay occurred or notification was issued for the change. The Contractor shall not sequester shared float through such strategies as excessively extending durations, artificially constraining resources, or introducing faulty logical relationships between schedule activities.

6.2.3 The Contractor shall prepare and maintain the Contract Schedule by the use of skilled and experienced scheduling personnel; each with at least five (5) years experience or the equivalent thereof in detailed scheduling. Such personnel shall be directly involved in the planning, scheduling, evaluating, and progress reporting of the work. The Contractor shall submit the qualifications of the scheduler/scheduling consultant for approval at the Pre-Construction Meeting. Should the scheduler/scheduling consultant's qualifications prove unacceptable to NJ TRANSIT, the Contractor shall submit the qualifications of a substitute scheduler/scheduling consultant within seven (7) calendar days of NJ TRANSIT's rejection of the originally proposed personnel.

- 6.2.4 No later than ten (10) calendar days after the Notice to Proceed, Contractor shall submit to the Construction Manager a Detailed Project Schedule (DPS). This DPS shall outline all activities and sequences of operations, as needed, for the orderly performance and timely completion of all work in accordance with the Contract, commencing with the Notice to Proceed and concluding with the Contract completion. The schedule should take into account mandatory sequencing, phasing, and restrictions of access to the Project Area, if any. The DPS is required to ensure adequate planning and scheduling of the work by Contractor and to enable the Construction Manager to evaluate work progress and to make progress payments. No progress payments (excluding payments for mobilization) will be made until a DPS is approved by the Construction Manager.
- 6.2.5 Within twenty-one (21) calendar days of receipt of Contractor's DPS, the Construction Manager will review the schedule for conformance with the Contract and provide the Contractor with the Construction Manager's comments. The Contractor shall incorporate the Construction Manager's comments into the DPS and shall resubmit the DPS to the Construction Manager within ten (10) calendar days of receipt of such comments. Contractor shall repeat this process (at its own expense) until the Construction Manager approves the DPS.
- 6.2.6 Upon approval by the Construction Manager, the Contractor's DPS shall become the Baseline Schedule for the work. This schedule shall be used by Contractor for planning, scheduling and executing the work, for monitoring and reporting progress to the Construction Manager, and as a basis for progress payments. Progress shall be shown in terms of remaining duration, actual dates and percent complete for each activity. During the life of this Contract, Contractor shall make monthly progress updates to the DPS. The updated DPS reflecting progress through the end of the month, as determined by NJ TRANSIT during the schedule meetings, shall be submitted by the fifth work day of the following month. Under no circumstances at any time during the project shall the Contractor make any changes to the NJ TRANSIT-approved Baseline Schedule logic, durations and construction sequencing without first receiving the written approval of the Construction Manager.
- 6.2.7 The DPS shall be a CPM schedule prepared with the software "Primavera", latest version, using the precedence diagram method. The DPS shall show a clear and definable critical path for the work. All imposed or constrained dates shall be clearly identified. The DPS shall include all contractual milestones and activities for the complete scope of the work including interface activities with the Railroad and other parties such as utility companies and outside agencies. Contractor's activities shall delineate the individual components of the work such as design efforts, submittals, procurement activities, fabrication, deliveries, construction operations, application and receipt of permits, track usage requirements, and testing. For each activity in the DPS, Contractor shall include:
1. Description, which shall clearly describe the operation and the location where it is occurring.
  2. Durations, which shall be expressed in calendar days. Durations shall not exceed twenty (20) calendar days except in the case of non-construction activities such as the site specific work plan

review, procurement of materials, fabrication and delivery of equipment or other such activities. Durations shall include allowances for lost time and inefficiencies. Activities that have started shall show the remaining duration.

3. Activity code, which will be utilized to allow for breakdown of the total schedule by work area, phase of work, activity type, etc. A responsibility code (as part of the activity code), shall individually and singularly denote Contractor, each Subcontractor, the Railroad, outside agencies, utilities, and any other parties performing the activity.
4. The number of person-hours required performing the activity. The number of person-hours shall be shown as a resource using integers.
5. The percent complete using integers, which represents the activity's progress as of the status date.
6. The actual start and finish dates.

6.2.8 Every DPS Submittal shall include a 3-1/2 inch diskette containing the Contract schedule and all related files generated by the "Primavera" back-up utility and shall include five hard copies of the following graphical and tabular reports:

1. Graphical:
  - a. Activity Bar Chart (ABC), on 8-1/2 inch by 11 inch or 11 inch by 17 inch paper with activities grouped by work areas and sorted by early start.
2. Tabular:
  - a. Activity Listing Report (ALR), sorted by activity identifier and including predecessor activities, successor activities, resources, and allocated dollar amount. Show constraint dates on a separate line.
  - b. Total Float Report (TFR), sorted by total float with a secondary sort by early start and including predecessor activities and successor activities.
  - c. Early Start Report (ESR), sorted by early start with a secondary sort by total float.
  - d. Cost Control Activity Report (CCAR), sorted by activity identifier and including the dollar amount earned to date for each activity (to be used as invoice back up).
  - e. Predecessor-Successor Report (PSR), sorted by activity number.

6.2.9 Every DPS Submittal shall include a written Narrative Report explaining the CPM schedule and the Contractor's approach for meeting the interim and completion milestones. This report will include an analysis and summary of the contents of the computer reports and will address, as a minimum, the following:

1. Description of the project status.
2. Critical path analysis which takes into account construction sequencing, major procurement items that may influence the critical path, activities that influence interim contract milestones, and NJ TRANSIT approved constraint dates.



3. Total float
4. Schedule slippage, including a comparison to the previous month's status.
5. List of activities that may become critical within the next 30 day period.
6. Logic revisions/other changes as approved by NJ TRANSIT.
6. If the project falls behind, the measures the Contractor will take to get the project back on schedule.

6.2.10 In the event that it is necessary for Contractor to revise the durations, construction sequencing or logic of the DPS, the revised DPS shall be submitted to the Construction Manager for approval, at no additional cost to NJ TRANSIT. Minor changes to the DPS, such as re-sequencing of activities, may be approved at a Project or Schedule Meeting; a minor change is not considered a revision in the context of this Paragraph. However, a revision shall incorporate all previously made changes, major or minor, to reflect current as-built and as-planned conditions. Reasons for revisions may include, but are not limited to, the incorporation of an approved change order or changes required to recover lost time if the Construction Manager determines that work is not progressing in accordance with the Baseline Schedule. In the case of minor changes or revisions that were made to improve Contractor's work progress and are not part of a change order, the monetary value of the activities in the revised portion of the schedule shall be identical, in aggregate value, to the value of that same work as reflected in the initial Baseline Schedule.

6.2.11 NJ TRANSIT will conduct Schedule Meetings as necessary with the Contractor to review and discuss the schedule. Schedule Meetings will generally be held as part of a progress meeting. If necessary, they shall be held as separate meetings. All Schedule Meetings shall be attended by the Contractor's Project Manager or a designee, who shall have the authority to make decisions on behalf of, and commit the resources of, the Contractor. The Contractor's superintendent and appropriate scheduling staff shall also attend the meetings. At these meetings, NJ TRANSIT will examine and comment on the Contractor's DPS. Schedule slippages will be analyzed and corrective actions will be discussed and agreed upon.

6.2.12 The Construction Manager will plan the Schedule Meetings so that, regardless of frequency, there will always be a Schedule Meeting taking place on or about the 25th day of the month. During this "monthly" Schedule Meeting, in addition to the in-depth review of the DPS, the Project progress (i.e., completed activities and percent complete of partially completed activities) shall be presented by the Contractor and reviewed by NJ TRANSIT. NJ TRANSIT shall determine the percent of work complete and advise the Contractor accordingly. Subsequent to this meeting, the DPS shall be updated with the progress, as determined by NJ TRANSIT, and the Contractor shall submit the monthly Narrative Report and the revised DPS to the Construction Manager as part of its Payment Application. NJ TRANSIT's review of the DPS and Narrative Report shall not constitute NJ TRANSIT's approval of any Contractor changes to the logic, durations and construction sequencing of the previously approved Baseline Schedule unless NJ TRANSIT specifically confirms in writing its acceptance of such changes.

- 6.2.13 In the event of a change order, the Contractor must clearly demonstrate how it proposes to incorporate the change order into the schedule. The Contractor shall provide, as part of its change order documentation and prior to change order negotiations, a schedule that clearly identifies the newly introduced change order work activities, the CPM path(s) affected and a narrative explaining the schedule impact of the change order to the DPS. If Contractor fails to notify the Construction Manager of the schedule changes associated with a change order, it will be deemed an acknowledgment by Contractor that the change order has no impact on the schedule.
- 6.2.14 All change order work activities shown in the schedule are considered to be tentative unless a Directive Letter or Change Order has been issued incorporating the changed Work into the Contract. Acceptance of a schedule containing change order work activities will not be construed to be approval of the value of the change, the duration of the work or constraints concerning the changed activities. The applicable Directive Letter or Change Order shall govern the monetary value and Contract Time impact of the changed work.
- 6.2.15 The Contractor shall furnish sufficient labor, plant and equipment to insure the prosecution of the work in accordance with the approved Project Schedule. If, in the opinion of the Construction Manager, the Contractor falls behind in the prosecution of the Work as indicated in the Project Schedule, the Contractor shall take such steps as may be necessary to improve its progress. The Construction Manager may require the Contractor to increase the number of shifts, days of work, and/or the amount of plant and equipment, all without additional cost to NJ TRANSIT.
- 6.3 CONTRACT DRAWINGS AND SPECIFICATIONS
- 6.3.1 Unless otherwise provided in the Contract Documents, NJ TRANSIT will furnish to the Contractor, free of charge, a maximum of six (6) full size copies of conformed Drawings and Specifications for the execution of the work. The Contractor shall at all times keep one copy of all Contract Documents up to date and in good order, available to the Engineer and to the Engineer's representatives. The Contractor shall keep its prints of the Contract Drawings up to date at all times by marking on them the final location of any changes in the Work. Prior to final payment the Contractor shall submit a copy of the marked-up drawings of all Contract Drawings whether altered or not to the Construction Manager. These marked up As-Built Drawings shall become the property of NJ TRANSIT.
- 6.3.2 The Engineer or NJ TRANSIT may furnish additional detail instructions to the Contractor through the Construction Manager, by means of supplemental drawings or otherwise, necessary for the proper execution of the work. Such drawings and instructions shall be consistent with the Contract Documents and reasonably inferable therefrom. The work shall be executed in conformity therewith and the Contractor shall do no work without proper drawings and instructions.

- 6.3.3 When the Contractor requests clarifications of Contract Drawings and Specifications it must give written notice to the Construction Manager with at least fourteen (14) calendar days lead time for the Construction Manager and Engineer to provide timely instruction or interpretation.
- 6.3.4 All Drawings referred to, together with such supplementary details as may be furnished or approved from time to time as the work progresses, are understood as being included in and a part of the Contract.
- 6.3.5 Dimensioned and full size drawings shall take precedence over scaled dimensions. Where the work is shown in complete detail on only half or a portion of a drawing or there is an indication of continuation, the remainder being shown in outline, the work drawn out in detail shall be understood to apply to other like portions of the Project.
- 6.4 GENERAL REQUIREMENTS FOR SUBMITTALS
- 6.4.1 The Contractor shall make all submittals required by the Contract Documents, and revise and resubmit as necessary to establish compliance with the specified requirements. Individual requirements for submittals are described in the Technical Provisions of these Specifications. Prior to each submittal, the Contractor shall carefully review and coordinate all aspects of each item being submitted and verify that each item and the submittal for it conforms in all respects with the requirements of the Contract Documents. By affixing the Contractor's signature to each submittal, the Contractor certifies that this coordination has been performed.
- 6.4.2 No later than thirty-five (35) calendar days after the Notice to Proceed, and before any items are submitted for review, the Contractor shall submit to the Construction Manager two (2) copies of the schedule described below.
- 6.4.3 The Contractor shall compile a complete and comprehensive schedule of all submittals anticipated to be made during progress of the Work which shall include a list of each type of item for which Contractor's drawings, shop drawings, Certificates of Compliance, material samples, guarantees, or other types of submittals are required. Upon review and approval of the Submittal Schedule by the Construction Manager, the Contractor will be required to adhere to the schedule except when specifically otherwise permitted in writing by the Construction Manager. The submittal schedule shall be incorporated into the Construction Project Schedule specified in Article 6.2.
- 6.4.4 The Contractor shall coordinate the submittal schedule with all necessary subcontractors and materials suppliers to ensure their understanding of the importance of adhering to the approved submittal schedule and their ability to so adhere. The Contractor shall coordinate as required to ensure the grouping of submittals as described in Sub-article 6.4.11 herein.

- 6.4.5 The Contractor shall, on a monthly basis, revise, update and submit the submittal schedule to the Construction Manager reflecting the actual conditions and sequences highlighting any changes from the previously approved schedule.
- 6.4.6 The Contractor shall submit documentation such as certificates, reports, test results, delivery tickets, manufacturers' literature, etc., as specified in the Technical Provisions to the Construction Manager for NJ TRANSIT's use and approval. Where contents of submitted literature from manufacturers or other submittals include data not pertinent to the submittal, the Contractor shall clearly indicate which portion of the contents is being submitted for review. The Contractor shall submit six (6) copies of each of the various items required to the Construction Manager, except that only one (1) copy of delivery ticket will be required. Three (3) copies will be returned to the Contractor.
- 6.4.7 The Contractor shall consecutively number all submittals and accompany each submittal with a letter of transmittal containing all pertinent information required for identification and checking of submittals to the satisfaction of the Construction Manager. The Contractor shall on at least the first page of each copy of each submittal, and elsewhere as required for positive identification, clearly indicate the submittal number in which the item was included.
- 6.4.8 When material is resubmitted for any reason, the Contractor shall transmit under a new letter of transmittal. All resubmittals shall carry the same submittal number as the original submittal except that an appendage ".01", ".02", ".03", etc. shall be added to indicate that the material is a first, second, third, etc. resubmission. For example, submission 177.01 would indicate the first resubmission; 177.02, would indicate a second resubmission; and 177.03, would indicate a third resubmission, etc.
- 6.4.9 The Contractor shall maintain an accurate submittal log for the duration of the Contract, showing current status of all submittals at all times and make the submittal log available for the Construction Manager's review upon request.
- 6.4.10 The Contractor shall, prior to submittal, use all means necessary to fully coordinate all material including, but not necessarily limited to:
- (a) Determining and verifying all interface conditions, catalog numbers, and similar data.
  - (b) Coordinating with other trades as required.
  - (c) Clearly indicating all deviations from requirements of the Contract Documents.
- 6.4.11 Unless otherwise specified, the Contractor shall make all submittals in groups containing all associated items to ensure that information is available for checking each item when unit is received. Partial submittals may be rejected by the Construction Manager as not complying with the provisions of the Contract Documents and the Contractor shall be strictly liable for all delays by such non-compliance.

6.4.12 The Contractor shall make all submittals in advance of schedule dates for installation to provide sufficient time required for reviews, for securing necessary approvals, for possible revisions and resubmittals, and for placing orders and securing delivery. All submittals shall be made within the first six (6) months of the Project.

6.4.13 In scheduling, the Contractor shall allow at least thirty (30) calendar days from receipt of the submittal for review. The Construction Manager will stamp all submittals "Received", and the date so stamped shall be the official receipt date. Delays caused by tardiness in receipt by the Construction Manager of submittals will not be an acceptable basis for extension of the Contract Time.

6.4.14 The Engineer's review of submittals will be general, but should not be construed:

- (a) As permitting any departure from the Contract requirements.
- (b) As offering relief from the responsibility for any errors, omissions or negligence in the preparation by the Contractor of details, dimensions, materials, etc.
- (c) As approving departures from details furnished by the Engineer, except as otherwise provided herein.

6.4.15 The Contractor shall take responsibility for and bear all cost of damages which may result from the ordering of any material or from proceeding with any part of the work prior to the final review by the Engineer of necessary submittals, including Shop and Working Drawings and all other required submittals.

6.4.16 Full compensation for furnishing all submittals shall be considered as included in the payments for the Contract Items to which such submittals relate and no additional compensation will be allowed therefor.

6.4.17 The provisions of Article 6.4 apply to all submittals.

## 6.5 SHOP AND WORKING DRAWING SUBMITTALS

6.5.1 The Contractor shall submit, with such promptness as to cause no delay in the work, a reproducible and five (5) legible copies and one sepia of all completed and detailed shop, setting or working drawings, details and schedules as are necessary to adequately perform the Work to the Construction Manager for review as to conformance to the design. By approving and submitting shop drawings, the Contractor thereby represents that it has determined and verified field measurements, field construction criteria, materials, catalog numbers, and similar data, or will do so, and that it has checked and coordinated each shop drawing with the requirements of the Work and of the Contract Documents. Drawings submitted by the Contractor on behalf of Subcontractors shall have been checked by the Contractor before being submitted.

6.5.2.1 The Engineer will review the shop and working drawings within thirty (30) calendar days. The sepia and three (3) copies will be returned to the Contractor reviewed and with comments. The Contractor shall make corrections if required by the Engineer and resubmit a reproducible and five (5) copies for approval. After final approval of the Drawings has been received, the Contractor shall immediately send the Engineer a minimum of three (3) prints of the finally approved drawings, plus the required number of approved prints each to every other affected Contractor. The Contractor shall prepare all work and shop drawings on sheets measuring 24 inches by 36 inches unless otherwise approved by the Construction Manager. The Contractor shall make all shop drawings and working drawings accurately to a scale sufficiently large to show all pertinent aspects of the item and its method of connection to the Work. The Contractor shall provide each drawing with a blank area 5 inches by 5 inches, located adjacent to the title block, and labeled as shown in the following Table. Failure to comply with these instructions will be sufficient reason to return such drawings to the Contractor without any action being taken. The title block shall display the following:

Table 6.5.2 Shop Drawing Labeling
Contract Number and Name
Number and Title of the Drawings
Date of Drawing and Revision Number
Name of Contractor and Subcontractor submitting Drawing
Clear identification of contents and location or work
Specification Article Number
Name; New Jersey State Registration Number and seal of professional Engineer certifying the drawings if engineering computations are involved or if original design work is depicted
Submittal Number

6.5.3 The Contractor's shop drawings shall show the general arrangement and such details as are necessary to provide a comprehensive description of the work to be performed. Shop Drawings shall consist of, but are not limited to, fabrication and erection drawings, schedule drawings, manufacturer's scale drawings, wiring and control diagrams, cuts of entire catalogs, pamphlets, descriptive literature, performance and test data.

6.5.4 Shop drawings for steel structures shall consist of shop, erection, and other drawings, showing details, dimensions, sizes, and other information necessary for the complete fabrication and erection of the metal work. Shop drawings for concrete structures shall consist of such additional detailed drawings as may be required for the prosecution of the work and may include drawings of falsework, bracing, centering, formwork, and masonry layout diagrams. The Contractor shall check completely the rod lists and details of reinforcement steel shown on the plans and shall submit complete shop drawings for the reinforcement steel to the Construction Manager for the Engineer's review. Material specification designations for the various components of the structures shall be noted on the drawings. If structural steel is scheduled for payment on the basis of weight, shop drawings for steel structures shall include a shop bill of material on each individual drawing showing pertinent information including weights of items together with the total weight of steel for that shop drawing.

6.5.5 Working Drawings shall consist of, but are not limited to, plans for temporary structures such as decking, temporary bulkheads, support of excavation, support of utilities, groundwater control systems and forming and falsework; for underpinning; and for such other work as may be required for construction but which does not become an integral part of the completed project. They shall be accompanied by calculations or other sufficient information to completely explain the structure or system described and its intended manner of use. The Contractor shall coordinate drawings for work on utilities, streets and other facilities which are constructed for owners other than NJ TRANSIT so that the information required by these other owners is included on the Working Drawings.

6.5.6 At the time of submission the Contractor shall inform the Engineer in writing of any deviation in the shop drawings from the requirements of the Contract Documents. If drawings show variations from the Contract requirements because of standard shop practice or for other reasons, the Contractor shall describe such variations in the letter of transmittal.

Failure to describe such variation to the Construction Manager, and the Engineer's review of shop drawings, shall not relieve the Contractor of responsibility for deviation from the requirements of the Contract Documents unless the Contractor has informed the Engineer in writing of such deviation at the time of submission and the Engineer has given written acceptance of the specific deviation. Neither shall the Engineer's review relieve the Contractor from responsibility for errors or omissions in the shop drawings nor relieve the Contractor from the responsibility for executing the work in accordance with the Contract.

6.5.7 Drawings Not In Conformance:

- (1) If corrections to the drawings are required, each print will be marked "REJECTED" or "FURNISH AS CORRECTED" or "REVISE AND RESUBMIT" and in each case the required corrections will be shown.
- (2) Each resubmittal will be handled in the same manner and review timeframe as the first submittal.
- (3) The Contractor shall direct specific attention, in writing or on the resubmitted drawings to revisions other than the corrections requested by the Engineer or Construction Manager on previous submittals.
- (4) If any corrections indicated on the drawings constitutes a change of the Contract requirements, the Contractor shall give direct and specific notice to the Construction Manager.
- (5) Work indicated on drawings marked "CONFORMS AS NOTED" or "FURNISH AS CORRECTED" may be carried out without resubmission if progressed "As Noted" or "As Corrected".

6.5.8 Drawings In Conformance:

- (1) Each copy of the drawings will be identified as conforming by being stamped, "REVIEWED", and dated by the Engineer.

- (2) When Shop and Working Drawings have been completed and stamped "REVIEWED," the Contractor shall carry out the construction in accordance therewith and make no further changes therein except upon written instructions from the Construction Manager.

## 6.6 SAMPLES SUBMITTALS

6.6.1 The Contractor shall furnish samples as required by the Contract Documents and as directed by the Construction Manager for review and acceptance. The work shall be in accordance with accepted samples. Such samples shall be submitted promptly to the Construction Manager, at the beginning of the work, so as to give the Construction Manager ample time to obtain approval from the Engineer. A list of samples required by the Construction Manager is for NJ TRANSIT's convenience only, and shall not be construed as limiting the number or type of samples which the Contractor shall furnish.

### 6.6.2 Procedure for Submittal of Samples:

- A. The samples submitted by the Contractor shall be of the precise article, product or material proposed to be furnished.
- B. The Contractor shall submit all samples in the quantity identified.
- C. The Contractor shall prepay all shipping charges on samples.
- D. The Contractor shall label each sample indicating the following:
  - (1) Name of Project and Contract Number;
  - (2) Name of Contractor and Subcontractor;
  - (3) Material or equipment represented;
  - (4) Source;
  - (5) Name of producer and brand (if any);
  - (6) Specification Section, article or paragraph;
  - (7) Location in Project; and
  - (8) Submittal Number.

## 6.7 PRODUCT AND SUBMITTALS

6.7.1 The Contractor shall, within thirty (30) calendar days after the notice to proceed date, notify the Construction Manager in writing of the names of manufacturers, products, and equipment. The Construction Manager may reject products or installed equipment not in conformance with the specifications. The Contractor shall properly submit complete identifying information, note whether the item is included in the Specifications and state Specifications Section and Paragraph. Requests for approval of alternate products and equipment (approved equals or substitutions) shall comply with the provisions of Sub-articles 6.7.3 or 6.7.4, as applicable.



- 6.7.2 Where a particular brand or manufactured product is specified, it is to be regarded as a standard. Another brand or make which meets or exceeds the specifications, in the sole discretion of the Project Manager, may be accepted, in accordance with Article 6.7.3.
- 6.7.2.1 The designs in the Contract are based on the named manufacturer's product(s) in each Section of the Technical Provisions. Where the Contractor proposes to use a product other than the named product(s), the Contractor shall pay all costs for modifications of the design, including all re-engineering costs and any additional construction costs associated with the use of that product. Written approval shall be obtained from the Engineer through the Construction Manager prior to any use of a product other than the named.
- 6.7.2.2 Where a performance is specified and no manufacturer is listed, the Contractor shall submit in accordance with Sub-article 6.7.1 the name of the manufacturer, the product proposed, and detailed information showing its characteristics.
- 6.7.2.3 Where a choice of color, pattern, or texture is available for a specified product, the Engineer will make a selection from the manufacturer's highest and best standards.
- 6.7.2.4 Where the Contractor requests that a manufacturer's product be added to the named list it shall follow the procedure set forth in Sub-article 6.7.3 below. Any NJ TRANSIT approval of an additional approved equal is subject to the conditions of Sub-article 6.7.2.1 above.
- 6.7.2.5 Where the Contractor requests that an alternate product be substituted for that specified the terms of Sub-article 6.7.4. below shall apply.
- 6.7.3 Request for Approved Equal: Should the Contractor desire to use a product other than the named manufacturer(s) product, it shall first make application to the Engineer through the Construction Manager in writing, otherwise it will be held to what is specified. The application shall clearly identify that it is a "Request for Approved Equal".
- 6.7.3.1 The procedure for submitting a request for an approved equal will be as follows: The Contractor shall submit five (5) copies of the request and data. The Contractor shall amend and update data when changes concerning information on products become known. The Contractor shall include the following information:
- a. Complete data substantiating compliance of proposed approved equal with requirements of the Specifications and Contract Drawings.
  - b. For products:
    - (1) Product identification, including manufacturer's name and address, model number and options.

- (2) Installation characteristics, installation drawings, manufacturer's literature including product description, performance and test data, and reference standards if pertinent.
- (3) Name and address of project(s) on which product was used under similar circumstances, and date of installation.
- c. For construction methods:
  - (1) Detailed description of proposed method.
  - (2) Drawings illustrating methods.
- d. Itemized comparison of proposed manufacturer's product with first-named product specified. Include differences in estimated life, estimated maintenance, availability of spare parts and repair services, energy consumption, performance capacity, salvageability, manufacturer's warranties, and other material differences. The Contractor may be required, at its own expense, to perform tests to demonstrate proof of equality.
- e. Data relating to changes in Construction Schedule.
- f. In making a request for an approved equal, Contractor is certifying:
  - (1) That it personally investigated the proposed product and method; that it believes, to the best of its knowledge and information, that product and method is either equivalent or superior to the product and method specified; and that it will update information as new or different data becomes known to the Contractor.
  - (2) That it will furnish the same guarantee as it would for the product and method specified.
  - (3) That it will coordinate installation of proposed product and method into the Work, and will make those changes required for the Work to be complete in all respects, all at no additional expense to NJ TRANSIT.
  - (4) That it waives all claims for additional costs and entitlement to any extension of Contract Time as a result of requesting approval of an approved equal, whether such approval is granted by NJ TRANSIT or not.

6.7.3.2 NJ TRANSIT reserves the right, at its sole discretion, to deny requests for approved equals should it deem the number of such requests to be excessive.

6.7.4 Requirements for Substitutions: The Contractor agrees that NJ TRANSIT is under no obligation to consider substitutions of any kind and may direct the Contractor to proceed with the work as specified. NJ TRANSIT shall not be liable for any costs or delays in action upon or for failure to act upon a proposed request for substitution. Requests for substitutions will not be considered if, in the opinion of the Project Manager, the substitutions are excessively broad in scope, require substantial revision of the Contract Drawings or Specifications, require substantial administrative effort and expense to review or are otherwise not in NJ TRANSIT's best interest.

Substitutions merely indicated or implied on shop drawings or product data submittals will not be considered if no formal request for substitution has been submitted in accordance with this Article. NJ TRANSIT's

approval of such a shop drawing or data submittal shall not constitute approval of a substitution and the Contractor shall be liable for all costs for corrective work to provide products in conformance with the Contract Documents.

When making a request for substitution, the Contractor shall follow the same procedural and data submission requirements as set forth in Sub-article 6.7.3 above, except that any such submission shall be clearly identified as a "Request for Substitution". The Contractor shall include the following additional information:

- a) A detailed cost breakdown of the proposed product in comparison to the product specified, naming the difference in cost in each case. The cost breakdown shall be submitted in the format specified in Article 3.2.
- b) A description of the benefit that will accrue to NJ TRANSIT should approval of the proposed substitution be granted.

If a substitute item is approved and the substitute item changes the scope of work under this or other contracts from the original specifications, then the Contractor offering the substitute item shall be responsible for all added costs and additional Contract Time involved by reason of the change in its work and the work of other contracts, including redesign. Any reduction in costs involved by reason of the change in its work shall be deducted from the Contract Price by Change Order. No change involving cost shall be made without the written consent of the Contracting Officer.

## 6.8 VALUE ENGINEERING SUBMITTALS

6.8.1 Value Engineering is defined as cost reduction proposals initiated and developed by the Contractor for changing the materials or other requirements of the Contract. This clause does not apply to such proposal unless it is identified by the Contractor at the time of submission to the Construction Manager or NJ TRANSIT as a proposal submitted pursuant to this clause. The cost reduction proposals contemplated are those that:

- (a) Would result in less costly items or components of items than those specified herein without impairing any of the items' essential functions and characteristics such as service life, reliability, economy of operation, ease of maintenance, and necessary standardized features; and
- (b) Would require, in order to be applied to this Contract, a Change Order to the Contract.

6.8.2 Cost reduction proposals as defined herein will be processed expeditiously and in the same manner as prescribed for any other proposal which would likewise necessitate issuance of a Change Order. As a minimum, the following information shall be submitted by the Contractor with each proposal:

- (a) A description of the difference between the existing Contract requirements and the proposed change, and the comparative advantages and disadvantages of each;
- (b) An itemization of the requirement of the Contract which must be changed if the proposal is adopted and suggested wording for revisions required;
- (c) An estimate of the reduction in performance costs that will result from adoption of the proposal taking into account the costs of implementation by the Contractor and the basis for the estimate;
- (d) A prediction of the effects the proposed change would have on other costs to NJ TRANSIT such as NJ TRANSIT furnished property costs, costs of related items, and costs of maintenance and operation;
- (e) A statement of the time by which a Change Order adopting the Proposal must be issued so as to obtain the maximum cost reduction during the remainder of the Contract, noting any effect on maintaining the Contract delivery schedule.

6.8.3 NJ TRANSIT shall not be liable for delays in action upon or for failure to act upon a proposal submitted pursuant to this clause. The decision of the Contracting Officer as to the acceptance or rejection of such proposal under this Contract shall be final and shall not be subject to the "Disputes" clause of this Contract. Unless and until a Change Order adding such proposal to the Contract is issued, the Contractor shall remain obligated to perform in accordance with the existing terms of the Contract. NJ TRANSIT may accept in whole or in part a cost reduction proposal submitted pursuant to this clause by issuing a Change Order which will identify the cost reduction on which it is based.

6.8.4 If a cost reduction proposal submitted pursuant to this clause is accepted under this Contract, an equitable adjustment in the Contract Price and in other affected provisions of this Contract shall be made in accordance with this clause. If the equitable adjustment involves a reduction in the Contract Price, it shall be established by determining the amount of the total estimated decrease in the Contractor's cost of performance resulting from the adoption of the cost reduction proposal, taking into account the cost of implementing the change by the Contractor, and reducing the Contract Price by 50 percent of such decrease.

## 6.9 PROGRESS PHOTOGRAPH SUBMITTALS

6.9.1 Prior to construction beginning and after construction operations have been started at the site, the Contractor shall have twenty (20) different color photographs taken each month, by a professional photographer, until completion of the Work. The Construction Manager will designate the location of views to be taken each month. The Contractor shall submit three (3) sets of prints of each photograph to the Construction Manager within ten (10) calendar days after taking.

6.9.2 The prints shall be standard commercial quality, 8 x 10 inches, single weight glossy paper. Each print shall have an information box, stamped on the back, 1-1/2 x 3-1/2 inches, and arranged as follows:

<b>Table 6.9.2 Photo Labeling</b>
NJ TRANSIT
Contract Name
Contract Number
Contractor
Photograph Number
Date
Submittal Number
Information regarding view such as location, direction or site and significant points of interest

6.9.3 The Contractor shall enclose the three (3) sets of photographs back-to-back in a double-faced plastic sleeve punched and bound in separate standard three-ring binders.

6.9.4 Negatives: The Contractor shall submit the negatives with the photos to the Construction Manager.

6.10 REPORTS, RECORDS AND DATA SUBMITTALS

The Contractor shall submit to the Construction Manager such schedules of quantities and costs, progress schedules, certified payrolls, reports, estimates, records and other data as NJ TRANSIT may request concerning work performed or to be performed under this Contract. The cost of submitting all such data shall not be paid separately and is considered paid for under the various items contained in the Bidder's Proposal.

6.11 AS-BUILT DRAWINGS AND QUANTITIES SUBMITTAL

6.11.1 The Contractor shall keep its prints of the Contract Drawings up to date at all times by marking on them the final location of any changes in the Work. These drawings shall be identified as the "Marked-Up Drawings". The data shall be transferred regularly by the Contractor to transparencies furnished by the Construction Manager at the expense of the Contractor.

6.11.2 Prior to final payment the Contractor shall submit a copy of the Marked-Up Drawings of all Contract Drawings whether altered or not to the Construction Manager with the Contractor's certifications as to the accuracy of the information. As built drawings shall be entitled "AS-BUILT" above the Title Block and dated. This information shall be reviewed by the Construction Manager; such review by the Construction Manager is for content only and not for accuracy and does not relieve the Contractor of its certification. The Contractor shall pay for the cost of reproduction. Upon completion of the Work and prior to release of final payment the Contractor shall transfer all as-built data to 24" x 36" transparencies (sepia mylar or mylars) at the expense of the Contractor. These Marked-Up Drawings and As-Built Drawings shall be submitted to and become the property of NJ TRANSIT.

- 6.11.3 Following acceptance of the Project, the Construction Manager will proceed with the preparation of as-built quantities for all Contract Items and Extra Work which has been authorized and incorporated into the Project. When such as-built quantities are completed, they will be incorporated into a proposed Final Certificate of Payment. The Contractor assumes the positive obligation of assisting the Construction Manager wherever possible in the preparation of such as-built quantities.
- 6.11.4 The Construction Manager may from time to time, prior to acceptance, prepare as-built quantities and incorporate these quantities into monthly estimate certificates through an appropriate field order or change order. Such interim as-built quantities shall be subject to recalculation following acceptance of the Project. However, nothing contained in these specifications shall be construed to place on the Construction Manager the obligation of providing the Contractor with as-built quantities for the work performed prior to the issuance of a Final Certificate of Payment, nor to provide more than rough, approximate quantities of the work done for use in the preparation of monthly estimates.
- 6.11.5 Should it appear to the Construction Manager at the time the Project is accepted that the calculation of as-built quantities might result in the Contractor being obliged to return money to NJ TRANSIT, NJ TRANSIT may, in its sole discretion, refuse to release retainages pending completion of the proposed Final Certificate of Payment. Where the estimate reveals that an overpayment has been made, the Contractor shall immediately return the amount of the overpayment. If the Contractor fails to remit the overpayment, NJ TRANSIT shall avail itself of other funds held on other projects with the same Contractor or against the retainages, and then if necessary proceed against the Contractor or its Surety. Where the proposed Final Certificate of Payment reveals that no overpayment has been made, the Contractor shall be entitled to payment thereunder and the release of retainages, but the Contractor shall have no claim of any kind for additional compensation as a result of NJ TRANSIT's decision to withhold retainages or other monies pending issuance of the proposed Final Certificate.

## **7. QUALITY ASSURANCE AND QUALITY CONTROL**

### **7.1 QUALITY ASSURANCE**

- 7.1.1 General: The Contractor shall establish and maintain a quality assurance program in accordance with ANSI/ASQC Q9001-1994. The program shall ensure compliance with the requirements of the Contract Documents and shall include provisions ensuring compliance by Subcontractors should any portion of the Work be subcontracted.
- 7.1.2 Six copies of the Contractor's quality assurance program shall be submitted to the Construction Manager at the pre-construction meeting for review and approval by the Construction Manager. Work undertaken by the Contractor before the Construction Manager's formal approval of the Contractor's program will be at the Contractor's sole risk and expense. A quality assurance audit of the Contractor's quality assurance program may be conducted by NJ TRANSIT at any time.

- 7.1.3 The Contractor's designated quality assurance program shall not be changed without the written concurrence of NJ TRANSIT. Work undertaken by the Contractor before receipt of written concurrence from NJ TRANSIT concerning such changes of the Contractor's quality assurance program will be at the Contractor's sole risk and expense.
- 7.1.4 The Contractor's quality assurance operations may be subject to NJ TRANSIT verification at any time. Verification shall include, but not be limited to: Audit of the quality assurance program; surveillance of the operations to determine that practices, methods, and procedures of the program are being properly implemented; inspection to measure the quality of items offered for acceptance; and inspection of items prior to release for shipment to ensure compliance with requirements of the Contract Documents.
- 7.1.5 Failure by the Contractor to promptly correct deficiencies discovered by the Contractor or of which the Contractor is notified by NJ TRANSIT may be cause for suspension of the Contract until corrective action has been taken or until conformance of the Work to prescribed criteria has been demonstrated to and approved by NJ TRANSIT. As a result of such suspension, no adjustment will be made with respect to increases in the cost or time.
- 7.2 MATERIAL - WORKMANSHIP - LABOR
- 7.2.1 Only approved materials shall be used, and the work shall be carefully carried out in strict accordance with the general and detail drawings. The Construction Manager shall have full power at any time to reject such work or material which does not, in the Construction Manager's opinion, conform to the true intent and meaning of the Contract Documents.
- 7.2.2 Work when completed in a substantial and workmanlike manner, to the satisfaction of the Construction Manager, shall be accepted by NJ TRANSIT in writing. Unless otherwise specified all materials used shall be new.
- 7.2.3 The Contractor shall furnish and pay for necessary transportation, scaffolding, centering, forms, water, labor, tools, light, power, and mechanical appliances, permits for the installation and construction of work, and all other means, materials, and supplies for properly prosecuting its work under the Contract, unless expressly specified otherwise. The Contractors and all Subcontractors shall rely on their own measurements for the performance of their work.
- 7.2.4 The Contractor shall furnish necessary and approved materials in ample quantities and as frequently as required to avoid delay in the progress of the work, and shall so store them as to prevent interference with work not under this Contract.
- 7.2.5 The Contractor shall employ qualified and competent personnel in their respective lines of work. Should the Construction Manager deem any employee incompetent or negligent or for any cause unfit for the

employee's duties, the Contractor shall dismiss that person, and that individual shall not again be employed on the Work; except that the permanent dismissal and replacement of any workers employed by a Disadvantaged Business Enterprise (DBE) Subcontractor or organization also requires the prior review of the NJ TRANSIT Office of Business Development in accordance with 49 C.F.R. Part 26.

7.2.6 The Contractor shall employ a full-time superintendent assigned solely to this Project who shall have full authority to act for the Contractor. It is understood that such representative shall be acceptable to the Construction Manager and shall be one who is to be continued in that capacity for the particular job involved unless that individual ceases to be on the Contractor's payroll.

The various Subcontractors shall have competent foremen in charge of their respective part of the work at all times. They are not to employ on the work an unfit person or anyone not skilled in the work assigned to that person.

The Contractor shall give the work its special supervision, lay out its own work, do the necessary leveling and measuring or employ a competent New Jersey licensed engineer or land surveyor satisfactory to the Construction Manager to do so. If, due to trade agreement, additional standby personnel are required to supervise equipment or temporary services used by other trades, the Contractor shall provide such standby services.

The superintendence and the number of workmen shall be sufficient to insure the completion of the Project within the time stipulated therefore.

7.2.7 No materials or supplies for the work shall be purchased by the Contractor or by any Subcontractor which are subject to a lien or other encumbrance or an agreement by which an interest is retained by the seller. The Contractor and all Subcontractors warrant that they have good title to materials and supplies used by them in the work, free from liens, claims or encumbrances.

7.2.8 Manufacturer's Instructions: Where installations include manufactured products, the Contractor shall comply with the manufacturer's applicable instructions and recommendations for installation to the extent that these instructions and recommendations are more explicit or more stringent than the requirements indicated in the Contract Documents.

7.2.9 Where the specifications or the manufacturer's instructions or warranty require that the site be visited and inspected by a representative of the manufacturer prior to the commencement of a particular item of work, the Contractor shall ensure that said visit or inspection occurs and that the Construction Manager be given no less than 24 hours notice of arrival of the manufacturer's representative.



### 7.3 INSPECTION OF WORK

- 7.3.1 NJ TRANSIT shall at all times have access to the work whether it is in preparation or in progress and the Contractor shall provide proper facilities for such access and for inspection and testing. NJ TRANSIT reserves the right, at its option, to employ the services of professional consultants for any phase of the work as it may deem to be in the best interest of NJ TRANSIT. The Contractor shall cooperate with NJ TRANSIT and these consultants and shall provide access to the work and facilities for inspection and testing.
- 7.3.2 If the Specifications, the Engineer's or Construction Manager's instructions, laws, ordinances or public or private authority require work to be specifically tested or approved, the Contractor so affected shall give the Construction Manager five (5) calendar days' notice in writing of its readiness for inspection, and if the inspection is by an authority other than the Construction Manager, of the date fixed for such inspection. Inspections by the Construction Manager will be promptly made. If such work should be covered up or otherwise concealed from view without approval or consent of the Construction Manager, it must, if required by the Construction Manager, be uncovered for examination and recovered after the examination at the Contractor's expense. There will be no extension of time to the Contract for uncovering or recovering work.
- 7.3.3 Except as otherwise provided herein, materials and installed equipment used in the construction of the Project shall be adequately tested according to standards of the trade, industry or as required by NJ TRANSIT, at the expense of the Contractor.
- 7.3.4 Whenever, in the Construction Manager's opinion, the Construction Manager considers it necessary or advisable to insure the proper implementation of the intent of the Contract Documents, the Construction Manager will have authority to require special inspection or testing of the work in addition to that required elsewhere in the Contract Documents, whether or not such work be then fabricated, installed or completed. However, neither the Construction Manager's authority to act under this Subsection, nor any decision made by the Construction Manager either to exercise or not to exercise such authority, shall give rise to any duty or responsibility of the Construction Manager to the Contractor, Subcontractor, their agents or employees, or any other person performing part of the work.
- 7.3.5 If after commencement of the Work the Construction Manager determines that some portion of the Work requires special inspection, testing or approval not provided for elsewhere in the Contract Documents, the Construction Manager will proceed with such inspection, testing or approval under contract with a third party for such services, or instruct the Contractor to order such special inspection, testing or approval. If such special inspection or testing reveals a failure of the Work to comply (1) with the requirements of the Contract Documents or (2) with respect to the performance of the Work, with laws, ordinances, rules, regulations or orders of public authority having jurisdiction, the Contractor shall bear all costs thereof, including the Construction Manager's additional services made necessary by such failure; otherwise NJ TRANSIT shall bear such costs, and an appropriate change order will be issued.

7.3.6 The Contractor shall cooperate fully with the Construction Manager and any testing company and supply materials for testing as required.

7.3.7 All construction subcode inspections shall be performed by the DCA Bureau of Code Services. The Contractor shall be responsible for requesting subcode inspections, as necessary, by contacting the DCA directly. The Contractor shall abide by all DCA instructions regarding subcode inspection procedures. The Contractor is responsible for notifying the Construction Manager of the time and date.

#### 7.4 PLANT INSPECTION

NJ TRANSIT may undertake the inspection of materials at the source. Manufacturing plants may be inspected periodically for compliance with specified manufacturing methods. Material samples may be obtained for laboratory testing for compliance with materials quality requirements. This may be the basis for acceptance of manufactured lots as to quality.

In the event plant inspection is undertaken the following conditions shall be met:

- (a) NJ TRANSIT shall have the cooperation and assistance of the Contractor and the producer with whom it contracted for the provision of materials and equipment.
- (b) NJ TRANSIT shall have full entry at all times to such parts of the plant as may concern the manufacture or production of the materials being furnished.
- (c) If required by NJ TRANSIT, the Contractor shall arrange for approved office space for the use of the inspector; such space to be located conveniently in or near the plant.
- (d) Adequate safety measures shall be provided and maintained.

It is understood that NJ TRANSIT reserves the right to retest materials which have been tested and accepted at the source of supply after the same have been delivered and to reject materials which, when retested, do not meet the requirements of the Contract Documents. The cost of retesting in case of rejection shall be borne by the Contractor.

#### 7.5 INSTALLED EQUIPMENT TESTING AND TRAINING

7.5.1 When mechanical, electrical or other equipment is installed it shall be the responsibility of the Contractor to operate it for a satisfactory period of time as required by the Contract Documents for proper testing of the equipment and instructing NJ TRANSIT operating personnel. Fuel, power, and other items or services required for proper testing of equipment and for the period of instruction shall be provided at the expense of the Contractor furnishing such equipment. The Contractor shall provide the Construction Manager with a minimum of five (5) business days prior written notice of the performance of a test. Tests shall be conducted in the presence of NJ TRANSIT. Test results shall be submitted and approved by NJ TRANSIT prior to acceptance of the installation.

- 7.5.2 The Contractor shall furnish six (6) copies of each "Operating and Maintenance Booklet" which shall contain not less than the following (as applicable to each trade):
1. Manufacturer's service manuals and equipment parts list of all functional components of the system including control diagrams, wiring diagrams of controllers, and explanation and description of each system;
  2. A complete typewritten list of all items of pertinent equipment including compressors, pumps, fans, motors, coils, etc. with nameplate date, capacities, model numbers, lubrication charts and preventive maintenance schedule;
  3. Trouble shooting guides and testing instructions;
  4. Manufacturer's parts list and ordering requirements;
  5. Names, addresses and telephone numbers of all manufacturers agents, Subcontractors, supply houses, etc. from which replacement parts, service and operating information can be obtained;
  6. The manuals shall be divided into indexed sections with tabs dividing sections, for A) Mechanical/HVAC, B) Electrical/Lighting, C) Finish Schedules.

7.5.3 The Contractor shall instruct NJ TRANSIT designated personnel as to the proper operation of all equipment and apparatus, and each of the various systems specified. No later than two weeks prior to conducting training sessions, the Contractor shall submit a Training Plan for the Construction Manager's approval. The Training Plan shall include the instructor's qualifications, the proposed training schedule and an outline of the instructor's lesson plan. Training session topics shall include, as a minimum, a detailed review of operating and maintenance procedures, spare parts, tool requirements, prescribed lubricants and fuels, hazards and warranties. The Contractor shall be responsible for providing all visual aids and training materials. Training sessions shall be conducted at a time and place convenient to NJ TRANSIT personnel.

The Contractor, after issuing complete instructions and direction to the NJ TRANSIT designated personnel, shall secure from such persons a signed acknowledgment in duplicate stating that complete and comprehensive instructions have been received and understood. The Contractor shall then forward the two copies of the signed acknowledgment to the Construction Manager for record purposes.

## 7.6 LABORATORY TESTING AND INSPECTION

### 7.6.1 General Requirements:

NJ TRANSIT will reimburse the Contractor for the services of an independent Testing Laboratory to perform structural steel, reinforced concrete, soils and any other testing services required by NJ TRANSIT. The Contractor shall cooperate with the laboratory to facilitate the execution of its required services. Employment of the laboratory shall in no way relieve the Contractor of its obligations to either perform any other testing and inspection work as required by the Contract Documents or to perform any other item of Work.

7.6.2 Related Requirements:

- A. Laboratory Selection: The Contractor shall submit the name and qualifications of three independent testing laboratories for approval to the Construction Manager. The Contractor shall solicit pricing from each prospective testing and inspection laboratory for the services requested by NJ TRANSIT. The pricing information shall be submitted with the qualification submissions listed in Sub-article 7.6.3. The Construction Manager shall determine the best qualified laboratory.
- B. Payment: Payment for the services described herein shall be made only for work which is actually performed and approved by NJ TRANSIT. Payment shall be at the rates quoted for the services listed in the Special Provisions and shall be in effect from the Notice to Proceed date and for a two year period thereafter.

Rates and fees are to be based on work performed between 8:30 a.m. and 4:30 p.m.; overtime rate of 1-1/2 times the corresponding hourly rates may be applied for work performed after 4:30 p.m. and before 8:30 a.m. The overtime rate shall also be applicable for weekends and holidays.

Travel expenses for inspection and testing services rendered outside the 50 mile radius of Newark, New Jersey shall be completely documented to the satisfaction of NJ TRANSIT. Any out of town travel expenses shall be pre-approved via an estimate submitted by the laboratory.

NJ TRANSIT shall reimburse the Contractor for laboratory testing and inspection costs upon receipt of itemized invoices from the approved laboratory.

NJ TRANSIT shall pay only the amounts of the laboratory invoices, under the allowance amount included by NJ TRANSIT as a Bid Item in the Bidder's Proposal. The allowance may be adjusted upward or downward at NJ TRANSIT's sole discretion, to reflect actual costs. NJ TRANSIT shall pay for the initial testing only. Should any material fail to satisfy the test requirements, the Contractor shall be responsible for any additional costs and delays to retest or test replacement material.

7.6.3 Qualification of Laboratory:

To be qualified the laboratory shall:

- A. Meet "Recommended Requirements for Independent Laboratory Qualification", published by American Council of Independent Laboratories.
- B. Meet basic requirements of ASTM E329, "Standards of Recommended Practice for Inspection and Testing Agencies for Concrete and Steel as Used in Construction."
- C. Be authorized to operate in the State of New Jersey.

- D. Submit copy of report inspection of facilities made by Materials Reference Laboratory of National Bureau of Standards during the most recent tour of inspection, with memorandum of remedies of any deficiencies reported by inspection.
- E. Have testing equipment:
  - 1. Calibrated at reasonable intervals by devices of accuracy traceable to either:
    - a. National Bureau of Standards; or
    - b. Accepted value of natural physical constants.

#### 7.6.4 Laboratory Duties:

The laboratory shall promptly submit three (3) copies of a written report of each test and inspection to the Construction Manager for distribution. Each report shall include:

- 1. Date issued;
- 2. Project title and number;
- 3. Testing laboratory name, address and telephone number;
- 4. Name and signature of laboratory inspector;
- 5. Date and time of sampling or inspection;
- 6. Record of temperature and weather conditions;
- 7. Date of test;
- 8. Identification of product and specification section;
- 9. Location of inspection or test;
- 11. Results of tests and compliance with Contract Documents; and
- 12. Interpretation of test results, when requested by the Construction Manager.

#### 7.6.5 Limitation of Authority of Testing Laboratory:

Laboratory is not authorized to:

- 1. Release, revoke, alter or enlarge on requirements of Contract Documents;
- 2. Approve or accept any portion of the Work; or
- 3. Perform any duties of the Contractor.

#### 7.6.6 Contractor's Responsibilities:

- A. Cooperate with laboratory personnel, provide access to work, and to manufacturer's operations.
- B. Secure and deliver to the laboratory adequate quantities or representational samples of materials proposed to be used and which require testing.
- C. Provide to the laboratory the preliminary design mix proposed to be used for concrete, and other materials mixes which require control by the testing laboratory.
- D. Furnish copies of products test reports as required.

- E. Furnish incidental labor and facilities:
  - 1. To provide access to work to be tested;
  - 2. To obtain and handle samples at the Project Site or at the sources of the product to be tested;
  - 3. To facilitate inspections and tests; and
  - 4. For storage and curing of test samples.
- F. Notify laboratory sufficiently in advance of operations to allow for laboratory assignment of personnel and scheduling of tests. NJ TRANSIT reserves the right to have materials that were not properly tested, removed and replaced at no additional cost to NJ TRANSIT. When test or inspections cannot be performed after such notice, reimburse laboratory for laboratory personnel and travel expenses incurred due to Contractor's negligence.
- G. The Contractor shall have the laboratory perform additional tests as required by NJ TRANSIT

## 7.7 CERTIFICATION OF COMPLIANCE

Certain materials as specified elsewhere will be accepted on the basis of Certificates of Compliance stating that such materials or assemblies fully comply with the requirement of the Contract. The form of the Certificates of Compliance shall be approved by the Construction Manager.

Materials or assemblies used on the basis of Certificates of Compliance may be sampled and tested at any time and if found not to be in conformity with the Contract requirements, will be subject to rejection whether in place or not. The Contractor shall require the manufacturer or supplier to furnish three copies of Certificates of Compliance with each delivery of materials, components, and manufactured items that are acceptable by certification. Two copies shall be furnished to the Construction Manager and one copy shall be retained by the Contractor.

Certificates of Compliance shall contain the following information:

- (a) Project to which the material is consigned.
- (b) Name of the Contractor to which the material is supplied.
- (c) Kind of material supplied.
- (d) Quantity of material represented by the certificate.
- (e) Means of identifying the consignment, such as label marking, seal number, manufacturer or supplier, and such additional information as required to make positive identification.
- (f) Date and method of shipment.
- (g) A statement that the material has been tested and found in conformity with the pertinent Contract requirements stated in the certificate and that test results pertaining to the material are either on file with the producer and available upon request or attached to the certificate.
- (h) Signature of a person having legal authority to bind the supplier.

- (i) Signature attested to by a Notary Public.

No payments relative to materials specified to be accepted on the basis of Certificates of Compliance shall be made until the Construction Manager is in possession of an acceptable Certificate of Compliance.

A Certificate of Compliance shall not be construed as a waiver of NJ TRANSIT's right to test the material or assemblies supplied.

## 7.8 NON-CONFORMING WORK AND MATERIALS

7.8.1 Materials or work found to be defective, or not in strict conformity with the requirements of the Contract Documents, or defaced or damaged through the acts or omissions of a Contractor or its Subcontractors, or through action of fire, weather, vandalism or other causes, shall be removed immediately and new materials or work substituted therefor to the satisfaction of the Construction Manager without delays by the Contractor involved and at its sole cost and expense. Under no circumstances shall the Contractor be entitled to an extension of time for correcting defective work.

7.8.2 Should the Construction Manager determine that work, including work of an administrative nature, is not in conformance with the requirements of the Contract Documents, the Construction Manager shall issue a Non-Conformance Notice (NCN). The NCN shall state the work or material which is non-conforming and establish a reasonable time period for correcting the non-conforming work or material. Should the Contractor fail to correct, repair or replace the non-conforming work or material in a timely manner, NJ TRANSIT may take such actions as NJ TRANSIT deems necessary to protect NJ TRANSIT's and the public's interest, including but not limited to, withholding payments, suspending all or a portion of the Work, terminating the Contract for Default, denying future prequalification or Subcontractor approvals, and/or suspending or debaring the Contractor from bidding on future NJ TRANSIT contracts.

7.8.3 No previous inspection or certification shall be held as an acceptance of defective work or materials or to relieve the Contractor from the obligation to furnish sound materials and to perform good satisfactory work. The Engineer shall be the final judge of the materials and work furnished.

7.8.4 The Contractor shall be given every opportunity to correct defective or damaged work; however, if the Contracting Officer deems it inexpedient to have the Contractor correct work damaged or done not in accordance with the Contract, the difference in value between such work and that specified, as determined by the Contracting Officer, together with the cost and expense of correcting the work, shall be deducted from the Contract Price.

7.9 WARRANTY AGAINST DEFECTIVE WORK

7.9.1 In addition to other warranties set out elsewhere in this Contract, the Contractor warrants that work performed under this Contract conforms to the Contract requirements and is free of defect of equipment, material or design furnished, or workmanship performed by the Contractor or its Subcontractors or suppliers at any tier. Such warranty shall continue for a period of one year from the date of Acceptance of the Work. Under this warranty, the Contractor shall remedy at its own expense any such failure to conform or any such defect. In addition, the Contractor shall remedy at its own expense damage to NJ TRANSIT owned or controlled real or personal property, when that damage is the result of the failure of the Contractor or its Subcontractors or suppliers at any tier to conform to contract requirements or any such defect of equipment, material, workmanship, or design. The Contractor shall also restore work damaged in fulfilling the terms of this clause. The Contractor's warranty with respect to work repaired or replaced hereunder will run for one year from the date of the acceptance by NJ TRANSIT of such repair or replacement.

7.9.2 NJ TRANSIT shall notify the Contractor in writing within a reasonable time after the discovery of failure, defect, or damage. Should the Contractor fail to remedy failure, defect or damage described in the first paragraph of this Article within a reasonable time after receipt of notice thereof, NJ TRANSIT shall have the right to replace, repair, or otherwise remedy such failure, defect, or damage at the Contractor's expense.

7.9.3 In addition to the other rights and remedies provided by this clause, Subcontractor's, manufacturers', and suppliers' warranties, expressed or implied, respecting work and materials shall, at the direction of the Contracting Officer, be enforced by the Contractor for the benefit of NJ TRANSIT. In such case if the Contractor's warranty under the first paragraph of this Article has expired, a suit directed by NJ TRANSIT to enforce a Subcontractor's, manufacturer's or supplier's warranty shall be at the expense of NJ TRANSIT. The Contractor shall obtain warranties which the Subcontractors, manufacturers, or suppliers would give in normal commercial practice.

If directed by the Contracting Officer, the Contractor shall require any such warranties to be executed in writing to NJ TRANSIT.

7.9.4 Notwithstanding other provisions of this Article, unless such a defect is caused by the negligence of the Contractor or its Subcontractors or suppliers at any tier, the Contractor shall not be liable for the repair of defects of material or design furnished by NJ TRANSIT nor for the repair of damage which results from any such defect in NJ TRANSIT furnished material or design.

7.9.5 The warranty specified herein shall not limit NJ TRANSIT's rights under Article 13.3, COMPLETION AND FINAL ACCEPTANCE.



**8. EXCAVATION AND DIFFERING SITE CONDITIONS**

**8.1 UNCLASSIFIED EXCAVATION**

Unless otherwise provided elsewhere in this Contract, excavation work shall be considered unclassified excavation and shall consist of the removal of earth, rock, abandoned utilities, foundations and all other materials encountered of whatever nature.

**8.2 MEASUREMENT OF PAY LIMITS FOR EXCAVATION**

The method of measurement and establishment of pay limits for additions or deductions for excavation shall be as follows:

Basement Excavations: Pay limit for excavation shall be in accordance with cross sections limited by vertical parallel planes extending 24 inches outside of foundation walls shown on Contract Drawings, and horizontal plane along bottom of basement concrete slab or footings.

Pipelines and Encased Utilities: Pay limit for trench excavation shall be limited to width of 36 inches or the largest diameter of pipe barrel plus 24 inches, whichever is greatest and depth at bottom of pipe barrel. When rock is encountered, the Contractor shall excavate to six inches below bottom of pipe barrel. A six inch compacted granular fill for the pipe shall be provided by the Contractor. No additional payment will be made for this additional excavation of six inches and the granular fill.

Encased Electrical Conduit, Steam Transmission Lines, Unformed Foundation Footings: Width and depth of trench shall be limited to same width and elevations of structure shown on Contract Drawings.

Where unsuitable foundation material is encountered, the Contractor shall excavate to elevations as directed by the Construction Manager. Unit prices for additional excavation and replacement with approved compacted granular fill, if stated in the proposal form, shall be used as a basis for additional payment by NJ TRANSIT.

**8.3 SOIL BORINGS**

Where data pertaining to test pits, test borings, or any like information are given, by drawings or in writing, they are for general information only and shall not relieve the Contractor from the responsibility for making such investigations as may have been necessary to insure that its Bid was based on actual conditions.

**8.4 DIFFERING, LATENT OR UNUSUAL SITE CONDITIONS**

**8.4.1** The Contractor shall not proceed with the work at the site until it has satisfied itself that the topographic data in the Contract Documents are correct.

**8.4.2** Should the Contractor encounter subsurface and latent conditions at the site materially differing from those shown on the plans or indicated in the Specifications (Type I), it shall immediately give notice to the

Construction Manager of such conditions before they are disturbed. NJ TRANSIT will thereupon promptly investigate the conditions, and if it finds that they materially differ from those shown on the plans or indicated in the Specifications, it will promptly make such changes in the plans and/or Specifications as it may find necessary. Any increase or decrease of cost and time of completion resulting from such change shall be adjusted in the manner provided in Article 3.1, Contract Changes.

8.4.3 The Contractor shall promptly, and before such conditions are disturbed, notify the Construction Manager in writing of any other unknown physical conditions at the site, (Type II) of an unusual nature, differing materially from those ordinarily encountered and generally recognized as belonging in work of the character provided for in this Contract. NJ TRANSIT shall promptly investigate the conditions, and if it finds that such conditions do materially so differ that they could not have been discovered by the Contractor through employing the high standard of care required in the Contractor's pre-bid investigations and that they cause an increase or decrease in the Contractor's cost of, or the time required for, performance of any part of the Work under this Contract, an equitable adjustment shall be made in accordance with Article 3.2.

8.4.4 No claim of the Contractor under this Article shall be allowed unless the Contractor has given the written notice required above.

8.4.5 No claim by the Contractor for an equitable adjustment hereunder shall be allowed if asserted after substantial completion under this Contract.

8.4.6 The Contractor waives its right of claim if it disturbs the condition prior to submitting notice to the Construction Manager and before the Contracting Officer acts thereon.

## 8.5 ARCHEOLOGICAL FINDINGS

When the Contractor's excavating operations encounter prehistoric remains or artifacts of historical or archeological significance, the operations shall be temporarily discontinued in that area. NJ TRANSIT will consult archeological authorities and determine the disposition of the remains or artifacts. The discontinuance of the work shall be governed by Article 2.3, SUSPENSION OF WORK.

## 9. INDEMNIFICATION AND LIABILITY

### 9.1 INDEMNIFICATION; RISKS ASSUMED BY THE CONTRACTOR

9.1.1 The Contractor shall defend, indemnify and save harmless the State of New Jersey, NJ TRANSIT, the USDOT, the FTA (if the Contract is in whole or part federally funded) and their officers, employees, servants and agents from all suits, actions, or claims of any character including, but not limited to, expenditures and costs of investigations, hiring of witnesses, court costs, counsel fees, settlements, judgments or otherwise, brought because of any injuries or damage received or sustained by any person, persons, or property on account of the operations of said Contractor or its Subcontractors in the performance of the work specified in this Contract; or on account of or in consequence of any neglect in safeguarding the work as specified in

this Contract; or because of any act or omission, neglect, or misconduct of said Contractor or its Subcontractors in the performance of the work specified in this Contract; or from any claims or amounts arising or recovered under the Worker's Compensation Act, or any other law, ordinance, order, or decree. So much of the money due the said Contractor under and by virtue of this Contract as may be considered necessary by NJ TRANSIT for such purpose may be retained for the use of NJ TRANSIT; except that money due to the Contractor will not be withheld when the Contractor produces satisfactory evidence that it is adequately protected by public liability and property damage insurance. NJ TRANSIT shall, as soon as practicable after a claim has been made against it, give written notice thereof to the Contractor along with full and complete particulars of the claim. If the suit is brought against NJ TRANSIT, NJ TRANSIT shall immediately forward to the Contractor every claim, demand, complaint, notice, summons, pleading or other process received by NJ TRANSIT or its representatives. NJ TRANSIT shall have the right, but not the obligation, to participate, to the extent it deems appropriate, in the defense of the matter and must concur in the terms of any settlement or other voluntary disposition of the matter. In the defense of any such claims, demands, suits, actions and proceedings, the Contractor shall not raise or introduce, without the express written permission in advance of the Attorney General of the State of New Jersey, any defense involving in any way the immunity of NJ TRANSIT or the State of New Jersey, the jurisdiction of the tribunal over NJ TRANSIT or the State of New Jersey, or the provisions of any statutes respecting suits against NJ TRANSIT or the State of New Jersey.

9.1.2 The Contractor assumes the following distinct and several risks, whether they arise from acts or omissions whether negligent or not of the Contractor, its Subcontractors, suppliers, employees, agents, and others working for the Contractor on the Project, of NJ TRANSIT or of third persons, or from any other cause, and whether such risks are within or beyond the control of the Contractor, excepting only risks which arise from solely affirmative acts performed by NJ TRANSIT subsequent to the execution of the Contract with actual and willful intent to cause the loss, damage, and injuries described in Paragraphs (a) and (b) below:

- (a) Risks of Loss or Damage to the Construction: Until completion of all work and the acceptance of the Project by NJ TRANSIT, the Contractor shall have the charge and care of the work and of the materials to be used therein, whether permanent or temporary, including materials for which it has received partial payment and shall take every precaution against injury or damage to any part thereof by the action of the elements or from any other cause, whether arising from the execution or from the non-execution of the work. The Contractor shall rebuild, repair, restore, and make good all injuries or damages to any portion of the work occasioned by any of the above causes before acceptance and shall bear the expense thereof. However, the Contractor shall not assume the risk for damage to the work due to acts of war.

Where necessary to protect the work or materials from damage the Contractor shall in furtherance of the above Paragraph, but not by way of limitation, at its expense, provide suitable drainage for

the Project and erect such temporary structures as are necessary to protect the work or materials from damage. The risks for failure to take such actions are assumed by the Contractor.

In case of suspension of work from any cause whatever, the Contractor shall continue to be responsible for the Project as provided above and shall take such precautions as may be necessary to prevent damage to the Project, shall provide for drainage and shall erect necessary temporary structures, signs or other facilities. During such period of suspension of work, the Contractor shall properly and continuously maintain in an acceptable growing condition living material in newly established plantings, seedings, and soddings furnished under this Contract, and shall take adequate precautions to protect new tree growth and other important vegetative growth against injury. If ordered by NJ TRANSIT, the Contractor shall properly store during such suspension of work materials which have been partially paid for by NJ TRANSIT or which have been furnished by NJ TRANSIT. Such storage by the Contractor shall be on behalf of NJ TRANSIT. NJ TRANSIT shall at all times be entitled to the possession of such materials, and the Contractor shall promptly return the same to the site of the work when requested. The Contractor shall not dispose of any of the materials so stored except on written authorization from NJ TRANSIT. The Contractor shall be solely responsible for the loss of or damage to such materials.

- (b) Risk of Loss to Property in Performing the Work: The risk of loss or damage to any property of the Contractor, and of claims made against the Contractor or NJ TRANSIT for loss or damage to any property of subcontractors, supplier, workmen, and others performing the work, and to lessors, occurring at any time prior to completion of removal of such property from the construction site or NJ TRANSIT's premises, or the vicinity thereof shall be borne by the Contractor.

9.1.3 Neither the acceptance of the Project by NJ TRANSIT nor the making of final payment shall release the Contractor from its obligations under this Article. Moreover, neither the enumeration in this Subparagraph nor the enumeration elsewhere in this Contract of particular risks assumed by the Contractor or of particular claims for which it is responsible shall be deemed: (a) to limit the effect of the provisions of this Article or of any other provision of this Contract relating to such risks or claims; (b) to imply that it assumes or is responsible for risks or claims only of the type enumerated in this Article or in any other provision of this Contract; or (c) to limit the risks which it would assume or the claims for which it would be responsible in the absence of such enumerations.

9.1.4 The Contractor expressly understands and agrees that insurance protection required by the Contract, or otherwise provided by the Contractor, shall in no way limit the Contractor's responsibility to defend, indemnify, and save harmless NJ TRANSIT and the State as herein provided.

9.2 INSURANCE

The Contractor shall and shall require its Subcontractor(s) to procure and maintain until the issuance of the Final Certificate of Payment, the types of insurance specified below:

9.2.1 Fire Insurance and Extended Coverage (Builder's Risk):

The Contractor shall effect and maintain "All Risk" Builder's Risk insurance coverage, including terrorism coverage, for 100% of the Construction value upon the facility or facilities on which the work is to be executed or which is to be constructed, and shall also cover materials, equipment, and supplies of all kinds incident to the construction of said facility or facilities, in temporary structures, or on vehicles, or in the open.

9.2.2 Workers' Compensation Insurance:

The Contractor shall procure and shall maintain during the life of this Contract, Workers' Compensation Insurance, as required by applicable State law, for all of its employees to be engaged in work at the site of the Project under this Contract and, in case any such work is sublet, the Contractor shall require the Subcontractor similarly to provide Workers' Compensation Insurance for all of the latter's employees to be engaged in such work unless such employees are covered by the protection afforded by the Contractor's Workers Compensation Insurance. In case any class of employees on the Project under this Contract is not protected under the Workers' Compensation Statute, the Contractor shall provide and shall cause each Subcontractor to provide employer's liability insurance for the protection of such of its employees as are not otherwise protected. Limits of Employer Liability are as follows:

Employer's Liability

Bodily Injury by Accident	\$1,000,000 each accident
Bodily Injury by Disease	\$1,000,000 each employee
Bodily Injury by Disease	\$1,000,000 policy limit

9.2.3 Commercial General Liability Insurance:

The Contractor shall and shall require its Subcontractor(s) to procure and maintain during the life of this Contract, Commercial General Liability Insurance using ISO Occurrence Form CG0001 10/93 or equivalent. The policy shall provide a minimum amount of \$2,000,000 each occurrence, \$2,000,000 personal and advertising injury, \$4,000,000 general aggregate and \$4,000,000 products completed operations aggregate.

Coverage provided under this liability policy shall be on an occurrence basis and shall include, but not be limited to, bodily injury and property damage coverage including products liability/completed operations coverage, premises operations liability, blanket contractual liability, personal injury liability, independent contractors liability, mobile equipment, damage from explosion, collapse and underground hazards, and cross liability and severability of interests clause. Additional insured endorsement CG2026 11/85, CG 2010 11/85 or CG 2010 10/93 (but only if modified to include both ongoing and completed operations)

naming NJ TRANSIT, the State of New Jersey, and the Indemnified Parties and coverage must apply on a primary and non-contributory basis. The policy shall allow the Contractor to waive its and its insurer's rights of subrogation. There shall be no coverage exceptions for property containing or adjacent to railroad facilities or other transportation facilities..

The Contractor shall furnish completed operations insurance written to the limits stipulated herein for Commercial General Liability Insurance. Coverage shall be required and maintained in force for a minimum of three years following acceptance of the overall Contract, regardless of any beneficial occupancy by NJ TRANSIT during the Contract term.

9.2.4 Umbrella Liability Insurance

The Contractor shall and shall require its Subcontractors to procure and maintain umbrella liability insurance with a minimum limit of \$8,000,000 per occurrence and in the aggregate; coverage must follow form above underlying Commercial General Liability, Business Automobile Liability and Employer's Liability policies.

9.2.5 Automobile Liability Insurance

The Contractor shall and shall require its Subcontractor(s) to procure and maintain during the life of the Contract, Automobile Liability Insurance applicable to all owned, non-owned, hired or leased vehicles with a minimum of \$1,000,000 combined single limit per accident for bodily injury and property damage liability. This policy shall name NJ TRANSIT and the State of New Jersey as an additional insured.

9.2.6 Asbestos Abatement Liability –If applicable, the Contractor or whoever is performing the removal of any Asbestos Containing Material {ACM} shall maintain throughout the entire period of their performance under this Contract Asbestos Abatement Liability Insurance in the amount of \$2,000,000 per loss and \$2,000,000 in the aggregate. The Contractor or whoever is responsible for transporting and disposing of the {ACM} shall maintain throughout the entire period of their performance under this Contract Transportation Pollution Coverage {Form MCS90} in the amount of \$2,000,000 or statutory minimum whichever is greater.

9.2.7 Contractor's Pollution Liability Insurance

The Contractor and any Subcontractor performing construction and/or environmental remediation work must procure and maintain through the life of the Contract, Contractor's Pollution Liability Insurance, including lead abatement if required, covering the liability arising out of any sudden and non-sudden pollution or impairment of the environment, including bodily injury, property damage, clean-up costs and defense that arise from the work performed by the Contractor or its Sub-Contractor(s). Coverage under this policy shall have limits of liability with a minimum of \$5,000,000 per occurrence and shall be on an occurrence basis. The policy shall name NJ TRANSIT and the State of New Jersey as an additional insured. Transport of any hazardous waste generated under this Contract shall require Hazardous Waste

Haulers Insurance (MCS90) in an amount of \$5,000,000 per occurrence or statutory minimum, whichever is greater.

9.2.8 The Contractor and its Subcontractor(s) shall, at its own expense, carry all insurance which may be required to provide the necessary protection against loss or damage to any property of the Contractor or to any property of Subcontractors, suppliers, workmen, and others performing the work and to lessors, which insurance shall contain a waiver of any right of subrogation against NJ TRANSIT.

9.2.9 The insurance required herein shall provide adequate protection for the Contractor and its Subcontractors, respectively, against damage claims which may arise from operations under this Contract, whether such operations be by the insured or by anyone directly or indirectly employed by the Contractor and, also against any of the special hazards which may be encountered in the performance of this Contract.

9.2.10 The insurance policies are to be written by good and solvent insurance companies authorized to do business in New Jersey with an A.M. BEST Insurance Rating of "A-" or better or by such other companies acceptable to NJ TRANSIT in its sole discretion.

9.2.11 The Contractor shall furnish NJ TRANSIT with two copies of all Certificates showing the types, amount, class of operations covered, effective dates, and dates of expiration of policies. The policies evidencing required insurance shall contain an endorsement to the effect that cancellation or any material change in the policies adversely affecting the interests of NJ TRANSIT in such insurance shall not be effective for less than thirty (30) calendar days after written notice thereof to NJ TRANSIT. Evidence of such endorsement must be contained in the certificate of insurance. If requested by NJ TRANSIT, the Contractor shall also provide copies of the insurance policies covered by the certificate. The Contractor shall not commence work under this Contract until it has obtained the insurance required under this Paragraph and such insurance has been approved by the Contracting Officer, nor shall the Contractor allow any Subcontractor to commence work on its subcontract until the insurance required of the Subcontractor has been so obtained and approved.

If the insurance provided by the Contractor or any of its Subcontractor(s) fails to comply with the requirements listed herein, or if the Contractor or its Subcontractor(s) fails to maintain such insurance, then NJ TRANSIT maintains the right to stop work until proper evidence is provided.

9.2.12 The cost of providing the required insurance shall be included under the Bid Item "Mobilization" whenever such a Bid item is listed in the Bidder's Proposal. If no such item is listed then the cost shall be considered included under the total lump sum bid amount or allocated within the unit prices that sum to the total Bid price.

9.2.13 Railroad Protective Comprehensive General Liability Insurance:

Should it be required, NJ TRANSIT will provide Railroad Protective Comprehensive General Liability Insurance coverage for this Contract.

### 9.3 LIMITATIONS OF LIABILITY

In no event, whether under the provisions of this Contract, as a result of breach of Contract, tort (including negligence) or otherwise, shall NJ TRANSIT, the State, or USDOT, be liable to the Contractor for special, consequential, incidental or penal damages including, but not limited to, loss of profit or revenues, loss of rental value for Contractor owned equipment, damages to associated equipment, additional risk, cost of capital or interest of any nature (whether characterized as damages for the retention of money, an increase in the cost of performance, a penalty, or otherwise).

### 9.4 NO THIRD PARTY BENEFICIARIES

It is specifically agreed between the parties executing this Contract that it is not intended by any of the provisions of any part of the Contract to create the public or any member thereof a third party beneficiary hereunder, or to authorize anyone not a party to the Contract to maintain a suit for personal injuries or property damage pursuant to the terms or provisions of the Contract.

It is the further intent of NJ TRANSIT and the Contractor in executing this Contract that no individual, firm, corporation or any combination thereof, which supplies materials, labor, services or equipment to the Contractor for the performance of the work becomes thereby a third party beneficiary of this Contract. NJ TRANSIT and the Contractor understand that such individual, firm, corporation or combination thereof, has no right to bring an action in the courts of this State against the State or NJ TRANSIT, by virtue of this lack of standing and also by virtue of the provisions of the New Jersey Contractual Liability Act, N.J.S.A. 59:13-1, et seq.

### 9.5 PERSONAL LIABILITY OF PUBLIC OFFICIALS

In carrying out the provisions of the Contract, or in exercising power or authority granted to them by or within the scope of the Contract, there shall be no liability upon any NJ TRANSIT employee, either personally or as officials of the State, it being understood that in all such matters they act solely as agents and representatives of the State.

### 9.6 INTELLECTUAL PROPERTY

If the Contractor uses any design, device or materials covered by letters, patent or copyright, it shall provide for such use by suitable agreement with the owner of such patented or copyrighted design, device or material. It is mutually agreed and understood that, without exception, the Contract Price shall include all royalties or costs arising from the use of such design, device or materials in any way involved in the Work. The Contractor shall defend, indemnify and save harmless the State, USDOT, NJ TRANSIT, and their officers, agents, servants, and employees from any and all claims for infringement by reason of the use of such patented or copyrighted design, device or materials or any trademark or copyright in connection with



Work agreed to be performed under this Contract, and shall defend and indemnify the State, USDOT, NJ TRANSIT, and their officers, agents, servants, and employees, for any cost, expense or damage which it or they may be obliged to pay by reason of such infringement at any time during the prosecution of the Work or after completion of the Work.

9.7 ENVIRONMENTAL COMPLIANCE AND LIABILITY

9.7.1 The Contractor shall conduct all activities in compliance with all applicable federal, state and local laws, rules, regulations and permits designed to prevent or control the discharge of substances into the land, water and air and to protect individual health and safety. The Contractor will indemnify, hold harmless and defend NJ TRANSIT, the State of New Jersey, their directors, officers, employees, agents and assigns from and against any and all suits, actions, proceedings, costs, fines, penalties and claims arising from or alleged to have arisen from its violation of any such environmental, health or safety laws, rules, regulations or permits whenever such suits, actions, claims or proceedings shall be commenced, or whenever such costs are accrued, except for any violations, if any, at the NJ TRANSIT facility existing prior to the Contractor's activities. The Contractor shall take reasonable and necessary precautions to prevent the discharge of hazardous substances, including asbestos and petroleum products, onto NJ TRANSIT property or into the environment, including the air. Failure to comply will be considered grounds for default, and NJ TRANSIT may terminate the Contract in accordance with Article 2.5, TERMINATION FOR CAUSE. The indemnification obligations hereunder shall survive the completion or termination of this Contract.

9.7.2 No later than two weeks after the Notice to Proceed for this project, the Contractor shall supply to NJ TRANSIT a set of MSDS for any and all chemicals, materials or substances intended for use in the completion of the project that are covered by reference or definition by the OSHA Hazard Communication Standard (hereinafter HCS) and/or the New Jersey Worker and Community Right-to-Know Act, N.J.S.A. 34:5A-1 et seq. The chemical name and Chemical Abstract Service (hereinafter CAS) number must be provided for all hazardous substances and for the five most predominant ingredients. If this information is not available on the MSDS, the information must be provided under separate cover when the MSDS is submitted. The Contractor shall also supply to NJ TRANSIT a copy of its written hazard communication program as defined by the OSHA-HCS and the New Jersey Worker and Community Right-to-Know Act, N.J.S.A. 34:5A-1 et seq.

9.7.3 In addition to supplying NJ TRANSIT with the MSDS, the Contractor shall obtain the expressed written approval of NJ TRANSIT to use any chemicals with a flammability or reactivity hazard classification of 2, 3, or 4 as defined by the National Fire Protection Association Standard NFPA704.

9.7.4 During the performance of this contract, the Contractor shall take any and all necessary precautions to ensure that personnel and property of NJ TRANSIT, the Contractor, third parties, and the general public are not exposed to physical or health hazards from any of the aforementioned chemicals, materials and substances. In addition, the aforementioned chemicals, materials and substances shall be labeled with the

chemical name and CAS number of all hazardous substances including the five most predominant ingredients in accordance with the requirements of OSHA-HCS and the New Jersey Worker and Community Right-to-Know Act.

9.7.5 In the event the Contractor obtains any new information pertaining to the aforementioned chemicals, materials and substances during the performance of the work on this contract, the Contractor shall immediately make that information available to NJ TRANSIT.

9.7.6 The Contractor's format shall meet the requirements of OSHA-HCS. Alternative formats may be accepted provided they meet the requirements of the OSHA-HCS and New Jersey Worker and Community Right-to-Know Act.

## **10. ETHICAL REQUIREMENTS**

### **10.1 COVENANT AGAINST CONTINGENT FEES**

The Contractor warrants that no person or selling agency has been employed or retained to solicit or secure this Contract upon an agreement or understanding for a commission, percentage, brokerage, or contingent fee, except bona fide employees or bona fide established commercial or selling agencies maintained by the Contractor for the purpose of securing business. For breach or violation of this warranty, NJ TRANSIT shall have the right to annul this Contract without liability and in its discretion to deduct from the Contract Price, or otherwise recover, the full amount of such commission, percentage, brokerage or contingent fee.

### **10.2 OFFICIALS NOT TO BENEFIT**

10.2.1 Interest of Members of Congress: No member of or delegate to the Congress of the United States shall be admitted to any share or part of this Contract or to any benefit arising therefrom.

10.2.2 Interest of Public Officials: No member, officer or employee of NJ TRANSIT or the State shall have any interest, direct or indirect, in this Contract or the proceeds thereof. No former member, officer or employee of NJ TRANSIT who, during that person's tenure, had a direct, substantial involvement with matters that are related to this Contract, shall have any interest, direct or indirect, in this Contract or the proceeds thereof.

### **10.3 GRATUITIES**

10.3.1 The Contracting Officer may, by written notice to the Contractor, terminate the right of the Contractor to proceed under the Contract if it is found, after notice and hearing, that gratuities (in the form of entertainment, gifts or otherwise) were offered or given by the Contractor, or any agent or representative of the Contractor, to any officer, agent or employee of NJ TRANSIT with a view toward securing a contract or securing favorable treatment with respect to the performance of such Contract; provided that the existence of the facts upon which NJ TRANSIT makes its findings shall be in issue and may be reviewed in any competent court.

- 10.3.2 In the event this Contract is terminated as provided in the preceding Paragraph, NJ TRANSIT shall be entitled to pursue the same remedies against the Contractor as it could pursue in the event of a breach of the Contract by the Contractor.
- 10.4 NJ TRANSIT CODE OF ETHICS
- 10.4.1 It is NJ TRANSIT policy that Contractors must avoid all situations where proprietary or financial interest, or the opportunity for financial gain, could lead an officer or employee of NJ TRANSIT to secure favored treatment for any organization or individual. Contractors must also avoid circumstances and conduct which may not constitute actual wrongdoing, or conflict of interest, but might nevertheless appear questionable to the general public, thus compromising the integrity of NJ TRANSIT. For the purposes of this Article only, NJ TRANSIT shall be deemed to include any person contracting with NJ TRANSIT to perform services on the Project. All Contractors must comply with NJ TRANSIT's Code of Ethics contained in this Article.
- 10.4.2 The Contractor shall not employ any NJ TRANSIT officer or employee in the business of the Contractor or in professional activity in which the Contractor is involved with the NJ TRANSIT officer or employee.
- 10.4.3 The Contractor shall not offer or provide any interest, financial or otherwise, direct or indirect, to any NJ TRANSIT officer or employee, in the business of the Contractor or in professional activity in which the Contractor is involved with the NJ TRANSIT officer or employee. The Contractor shall not cause or influence, or attempt to cause or influence, any NJ TRANSIT officer or employee to act in his or her official capacity in any manner which might tend to impair the objectivity or independence of judgment of that NJ TRANSIT officer or employee.
- 10.4.4 The Contractor shall not cause or influence, or attempt to cause or influence, any NJ TRANSIT officer or employee to use or attempt to use his or her official position to secure any unwarranted privileges or advantages for that Contractor or any other person.
- 10.4.5 The Contractor shall not offer any NJ TRANSIT officer or employee any gift, favor, service or other thing of value under circumstances from which it might be reasonably inferred that such gift, service or other thing of value was given or offered for the purpose of influencing the recipient in the discharge of his or her official duties. In addition, employees or officers of NJ TRANSIT will not be permitted to accept breakfasts, lunches, dinners, alcoholic beverages, tickets to entertainment and/or sporting events, or any other item which could be construed as having more than nominal value.
- 10.4.6 In accordance with N.J.A.C. 16:72-4.1, the Contractor may be suspended and/or debarred if the Contractor:
- A. Makes any offer or agreement to pay or to make payment of, either directly or indirectly, any fee, commission, compensation, gift, gratuity, or other thing of value of any kind to any NJ TRANSIT Board member, officer, or employee or to any member of the immediate family of such Board

member, officer, or employee, or any partnership, firm, or corporation with which they are employed or associated, or in which such Board member, officer, or employee has an interest within the meaning of N.J.S.A. 52: 13D-13g;

- B. Fails to report to the Attorney General and to the State Ethics Commission in writing forthwith the solicitation of any fee, commission, compensation, gift, gratuity or other thing of value by any NJ TRANSIT Board member, officer, or employee;
- C. Undertakes, directly or indirectly, any private business, commercial, or entrepreneurial relationship with, whether or not pursuant to employment, contract or other agreement, express or implied, or sale, directly or indirectly of any interest in such Contractor to, any NJ TRANSIT Board member, officer, or employee having any duties or responsibilities in connection with the purchase, acquisition, or sale of any property or services by or to NJ TRANSIT, or with any person, firm, or entity with which he has an interest within the meaning of N.J.S.A. 52:13D-13g. Any relationship subject to this provision shall be reported in writing forthwith to the State Ethics Commission, which may grant a waiver of this restriction upon application of the NJ TRANSIT Board member, officer, or employee upon a finding that the present or proposed relationship does not present the potential, actuality, or appearance of a conflict of interest;
- D. Influence or attempts to influence or causes to be influenced, any NJ TRANSIT Board member, officer, or employee in his official capacity in any manner which might tend to impair the objectivity or independence of judgment of such Board member, officer, or employee; or
- E. Causes or influences or attempts to cause or influence, any NJ TRANSIT Board member, officer, or employee to use, or attempt to use, his official position to secure unwarranted privileges or advantages for the Contractor or any other person.

## **11. SOCIAL AND ECONOMIC REQUIREMENTS**

### **11.1 NEW JERSEY PREVAILING WAGE ACT**

11.1.1 The Contractor and each Subcontractor shall comply with the New Jersey Prevailing Wage Act, N.J.S.A. 34:11-56.25 et seq., and this Act is hereby made a part of this Contract. All workers shall be paid not less than the prevailing wage rate as designated by the Commissioner of Labor and Industry or the Commissioner's duly authorized deputy or representative.

In the event it is found that any worker has been paid a rate of wages less than the prevailing wage required to be paid by this Contract, the Contracting Officer may terminate the Contractor's or Subcontractor's right to proceed with the work, or such part of the work as to which there has been a failure to pay required wages, and take such action it deems necessary or prosecute the work to completion.

NJ TRANSIT shall furnish as part of the Contract a copy of the prevailing minimum wage rates which shall be paid to the workers employed in the performance of the Contract.

- 11.1.2 Nothing contained in the Prevailing Wage Act shall prohibit the payment of more than the prevailing wage rate to any worker employed on the Project.
- 11.1.3 The Contractor and each Subcontractor performing work for NJ TRANSIT who is subject to the provisions of the Prevailing Wage Act shall post the prevailing wage rates for each craft and classification involved, including the effective date of any changes thereof, in prominent and easily accessible places at the site of the work or at such place or places as are used by them to pay workers their wages.
- 11.1.4 The Bidder's signature on the proposal is its guarantee that neither it nor any Subcontractor it intends to contract with is currently listed by or on record with the Commissioner of Labor and Industry as one who failed to pay the prevailing wages according to the Prevailing Wage Act.
- 11.1.5 The Contractor and all of its Subcontractors performing work at the site must prepare their Bids as to labor costs in accordance with the prevailing wage (valid for the date the Bids are to be submitted) for the geographical area of the Project Site.
- 11.1.6 After the completion of all construction work and before the proposed Final Certificate of Payment will be issued, the Contractor and Subcontractors shall furnish the Construction Manager with written statements in form satisfactory to NJ TRANSIT certifying to the amounts then due and owing from the Contractor and Subcontractors filing such statement to any and all workers for wages due on account of the Contract, setting forth therein the names of the persons whose wages are unpaid and the amount due to each respectively, which statement shall be verified by the oath of the Contractor or Subcontractor, as the case may be, that it has read such statement subscribed by the Contractor or Subcontractor, knows the contents thereof, and that the same is true of its own knowledge, provided, however, that nothing herein shall impair the right of the Contractor to receive Final Payment because of failure of any Subcontractor to comply with provisions of this Article.

11.2 EQUAL OPPORTUNITY

11.2.1 Equal Employment Opportunity

The Contractor hereby acknowledges that pursuant to N.J.A.C. 17:27-3.1, NJ TRANSIT cannot award a contract or pay money to any Contractor or Subcontractor which has not agreed and guaranteed to afford equal employment opportunity in performance of the contract in accordance with an affirmative action program and, except with respect to affectional or sexual orientation, approved under the terms established in N.J.A.C. 17:27.

MANDATORY EQUAL EMPLOYMENT OPPORTUNITY LANGUAGE FOR CONSTRUCTION CONTRACTS (required by N.J.S.A. 10:5-31 et seq. and N.J.A.C. 17:27-1.1 et seq.) – EXHIBIT B (last revised 4/10)

During the performance of this contract, the contractor agrees as follows:

The contractor or subcontractor, where applicable, will not discriminate against any employee or applicant for employment because of age, race, creed, color, national origin, ancestry, marital status, affectional or sexual orientation, gender identity or expression, disability, nationality or sex. Except with respect to affectional or sexual orientation and gender identity or expression, the contractor will ensure that equal employment opportunity is afforded to such applicants in recruitment and employment, and that employees are treated during employment, without regard to their age, race, creed, color, national origin, ancestry, marital status, affectional or sexual orientation, gender identity or expression, disability, nationality or sex. Such equal employment opportunity shall include, but not be limited to the following: employment, upgrading, demotion, or transfer; recruitment or recruitment advertising; layoff or termination; rates of pay or other forms of compensation; and selection for training, including apprenticeship. The contractor agrees to post in conspicuous places, available to employees and applicants for employment, notices to be provided by the Public Agency Compliance Officer setting forth provisions of this nondiscrimination clause.

The contractor or subcontractor, where applicable will, in all solicitations or advertisements for employees placed by or on behalf of the contractor, state that all qualified applicants will receive consideration for employment without regard to age, race, creed, color, national origin, ancestry, marital status, affectional or sexual orientation, gender identity or expression, disability, nationality or sex.

The contractor or subcontractor will send to each labor union, with which it has a collective bargaining agreement, a notice, to be provided by the agency contracting officer, advising the labor union or workers' representative of the contractor's commitments under this act and shall post copies of the notice in conspicuous places available to employees and applicants for employment.

The contractor or subcontractor, where applicable, agrees to comply with any regulations promulgated by the Treasurer, pursuant to N.J.S.A. 10:5-31 et seq., as amended and supplemented from time to time and the Americans with Disabilities Act.

When hiring or scheduling workers in each construction trade, the contractor or subcontractor agrees to make good faith efforts to employ minority and women workers in each construction trade consistent with the targeted employment goal prescribed by N.J.A.C. 17:27-7.2; provided, however, that the Dept. of LWD, Construction EEO Monitoring Program, may, in its discretion, exempt a contractor or subcontractor from compliance with the good faith procedures pre-scribed by the following provisions, A, B, and C, as long as the Dept. of LWD, Construction EEO Monitoring Program is satisfied that the contractor or subcontractor is employing workers provided by a union which provides evidence, in accordance with standards prescribed by the Dept. of LWD, Construction EEO Monitoring Program, that its percentage of active "card carrying" members who are minority and women workers is equal to or greater than the targeted employment goal established in accordance with N.J.A.C. 17:27-7.2. The contractor or subcontractor agrees that a good faith effort shall include compliance with the following procedures:

- (A) If the contractor or subcontractor has a referral agreement or arrangement with a union for a construction trade, the contractor or subcontractor shall, within three business days of the contract award, seek assurances from the union that it will cooperate with the contractor or subcontractor as it fulfills its affirmative action obligations under this contract and in accordance with the rules promulgated by the Treasurer pursuant to N.J.S.A. 10:5-31 et seq., as supplemented and amended from time to time and the Americans with Disabilities Act. If the contractor or subcontractor is unable to obtain said assurances from the construction trade union at least five business days prior to the commencement of construction work, the contractor or sub-contractor agrees to afford equal employment opportunities minority and women workers directly, consistent with this chapter. If the contractor's or subcontractor's prior experience with a construction trade union, regardless of whether the union has provided said assurances, indicates a significant possibility that the trade union will not refer sufficient minority and women workers consistent with affording equal employment opportunities as specified in this chapter, the contractor or subcontractor agrees to be prepared to provide such opportunities to minority and women workers directly, consistent with this chapter, by complying with the hiring or scheduling procedures prescribed under (B) below; and the contractor or subcontractor further agrees to take said action immediately if it determines that the union is not referring minority and women workers consistent with the equal employment opportunity goals set forth in this chapter.
- (B) If good faith efforts to meet targeted employment goals have not or cannot be met for each construction trade by adhering to the procedures of (A) above, or if the contractor does not have a referral agreement or arrangement with a union for a construction trade, the contractor or subcontractor agrees to take the following actions:
- (1) To notify the public agency compliance officer, the Dept. of LWD, Construction EEO Monitoring Program, and minority and women referral organizations listed by the Division pursuant to N.J.A.C. 17:27-5.3, of its workforce needs, and request referral of minority and women workers;
  - (2) To notify any minority and women workers who have been listed with it as awaiting available vacancies;
  - (3) Prior to commencement of work, to request that the local construction trade union refer minority and women workers to fill job openings, provided the contractor or subcontractor has a referral agreement or arrangement with a union for the construction trade;
  - (4) To leave standing requests for additional referral to minority and women workers with the local construction trade union, provided the contractor or subcontractor has a referral agreement or arrangement with a union for the construction trade, the State Training and Employment Service and other approved referral sources in the area;
  - (5) If it is necessary to lay off some of the workers in a given trade on the construction site, layoffs shall be conducted in compliance with the equal employment opportunity and non-discrimination standards set forth in this regulation, as well as with applicable Federal and State court decisions;

(6) To adhere to the following procedure when minority and women workers apply or are referred to the contractor or subcontractor:

- (i) The contractor or subcontractor shall interview the referred minority or women worker.
- (ii) If said individuals have never previously received any document or certification signifying a level of qualification lower than that required in order to perform the work of the construction trade, the contractor or subcontractor shall in good faith determine the qualifications of such individuals. The contractor or subcontractor shall hire or schedule those individuals who satisfy appropriate qualification standards in conformity with the equal employment opportunity and non-discrimination principles set forth in this chapter. However, a contractor or subcontractor shall determine that the individual at least possesses the requisite skills, and experience recognized by a union, apprentice program or a referral agency, provided the referral agency is acceptable to the Dept. of LWD, Construction EEO Monitoring Program. If necessary, the contractor or subcontractor shall hire or schedule minority and women workers who qualify as trainees pursuant to these rules. All of the requirements, however, are limited by the provisions of (C) below.
- (iii) The name of any interested women or minority individual shall be maintained on a waiting list, and shall be considered for employment as described in (i) above, whenever vacancies occur. At the request of the Dept. of LWD, Construction EEO Monitoring Program, the contractor or subcontractor shall provide evidence of its good faith efforts to employ women and minorities from the list to fill vacancies.
- (iv) If, for any reason, said contractor or subcontractor determines that a minority individual or a woman is not qualified or if the individual qualifies as an advanced trainee or apprentice, the contractor or subcontractor shall inform the individual in writing of the reasons for the determination, maintain a copy of the determination in its files, and send a copy to the public agency compliance officer and to the Dept. of LWD, Construction EEO Monitoring Program.

(7) To keep a complete and accurate record of all requests made for the referral of workers in any trade covered by the contract, on forms made available by the Dept. of LWD, Construction EEO Monitoring Program and submitted promptly to the Dept. of LWD, Construction EEO Monitoring Program upon request.

- (C) The contractor or subcontractor agrees that nothing contained in (B) above shall preclude the contractor or subcontractor from complying with the union hiring hall or apprenticeship policies in any applicable collective bargaining agreement or union hiring hall arrangement, and, where required by custom or agreement, it shall send journeymen and trainees to the union for referral, or to the apprenticeship program for admission, pursuant to such agreement or arrangement. However, where the practices of a union or apprenticeship program will result in the exclusion of minorities and women or the failure to refer minorities and women consistent with the targeted county employment goal, the contractor or subcontractor shall consider for employment persons referred pursuant to (B) above without regard to such agreement or arrangement; provided further, however, that the contractor or subcontractor shall not be required to employ women and minority advanced trainees and trainees in numbers which result



in the employment of advanced trainees and trainees as a percentage of the total workforce for the construction trade, which percentage significantly exceeds the apprentice to journey worker ratio specified in the applicable collective bargaining agreement, or in the absence of a collective bargaining agreement, exceeds the ratio established by practice in the area for said construction trade. Also, the contractor or subcontractor agrees that, in implementing the procedures of (B) above, it shall, where applicable, employ minority and women workers residing within the geographical jurisdiction of the union.

After notification of award, but prior to signing a construction contract, the contractor shall submit to the public agency compliance officer and the Dept. of LWD, Construction EEO Monitoring Program an initial project workforce report (Form AA-201) electronically provided to the public agency by the Dept. of LWD, Construction EEO Monitoring Program, through its web-site, for distribution to and completion by the contractor, in accordance with N.J.A.C. 17:27-7. The contractor also agrees to submit a copy of the Monthly Project Workforce Report once a month thereafter for the duration of this contract to the Dept. of LWD, Construction EEO Monitoring Program, and to the public agency compliance officer.

The contractor agrees to cooperate with the public agency in the payment of budgeted funds, as is necessary, for on-the-job and/or off-the-job programs for outreach and training of minorities and women.

(D) The contractor and its subcontractors shall furnish such reports or other documents to the Dept. of LWD, Construction EEO Monitoring Program as may be requested by the Dept. of LWD, Construction EEO Monitoring Program from time to time in order to carry out the purposes of these regulations, and public agencies shall furnish such information as may be requested by the Dept. of LWD, Construction EEO Monitoring Program for conducting a compliance investigation pursuant to N.J.A.C. 17:27-1.1 et seq.

**(NOTE: FOR THE PURPOSE OF THIS CONTRACT THE "PUBLIC AGENCY COMPLIANCE OFFICER" IS NJ TRANSIT'S VP CIVIL RIGHTS & DIVERSITY PROGRAMS AND THE "PUBLIC AGENCY" IS NJ TRANSIT.)**

11.2.2 The Contractor and all Subcontractors hereby agree that the provisions of N.J.S.A. 10:2-1 through 10:2-4 and N.J.S.A. 10:5-31 et seq. (P.L. 1975, c.127) as amended and supplemented, and the rules and regulations promulgated pursuant thereto are made a part of the Contract and are binding upon them.

11.2.3 The Contractor, Subcontractors, and their assignees shall guarantee an equal employment opportunity to Veterans of the Vietnam era, pursuant to N.J.S.A. 10:5-40. "Veterans of the Vietnam era" are defined by N.J.S.A. 10:5-39(c).

11.2.4 Antidiscrimination: In accordance with N.J.S.A. 10:2-1 the Contractor agrees that:

a. In the hiring of persons for the performance of work under this contract or any subcontract hereunder, or for the procurement, manufacture, assembling or furnishing of any such materials, equipment, supplies or services to be acquired under this contract, no Contractor, nor any person acting on behalf of such Contractor or Subcontractor, shall, by reason of race, creed, color, national origin, ancestry, marital status, gender identity or expression, affectional or sexual orientation or sex, discriminate against any person who is qualified and available to perform the work to which the employment relates;

b. No Contractor, Subcontractor, nor any person on his behalf shall, in any manner, discriminate against or intimidate any employee engaged in the performance of work under this contract or any subcontract hereunder, or engaged in the procurement, manufacture, assembling or furnishing of any such materials, equipment, supplies or services to be acquired under such contract, on account of race, creed, color, national origin, ancestry, marital status, gender identity or expression, affectional or sexual orientation or sex;

c. There may be deducted from the amount payable to the Contractor by the contracting public agency, under this contract, a penalty of \$ 50.00 for each person for each calendar day during which such person is discriminated against or intimidated in violation of the provisions of the contract; and

d. This contract may be canceled or terminated by the contracting public agency, and all money due or to become due hereunder may be forfeited, for any violation of this section of the contract occurring after notice to the Contractor from the contracting public agency of any prior violation of this section of the contract.

No provision in this section shall be construed to prevent a board of education from designating that a contract, subcontract or other means of procurement of goods, services, equipment or construction shall be awarded to a small business enterprise, minority business enterprise or a women's business enterprise pursuant to P.L.1985, c.490 (C.18A:18A-51 et seq.).

#### 11.2.5 Provision Mandated by Executive Order 151

Executive Order No. 151 enhances inclusion efforts for minorities and women to benefit from the New Jersey Economic Assistance and Recovery Plan and the American Recovery and Reinvestment Act of 2009 (ARRA). The Executive Order requires the inclusion of the following mandatory equal employment and affirmative action language in construction contracts:

It is the policy of NJ TRANSIT that its contracts should create a workforce that reflects the diversity of the State of New Jersey. Therefore, Contractors engaged by NJ TRANSIT to perform under a construction contract shall put forth a good faith effort to engage in recruitment and employment practices that further the goal of fostering equal opportunities to minorities and women.

The Contractor must demonstrate to the NJ TRANSIT's satisfaction that a good faith effort was made to ensure that minorities and women have been afforded equal opportunity to gain employment under the NJ TRANSIT's contract with the Contractor. Payment may be withheld from a Contractor for failure to comply with these provisions.

Evidence of a "good faith effort" includes, but is not limited to:

- a. The Contractor shall recruit prospective employees through the State Job bank website, managed by the Department of Labor and Workforce Development, available online at <http://NJ.gov/JobCentralNJ>.
- b. The Contractor shall keep specific records of its efforts, including records of all individuals interviewed and hired, including the specific numbers of minorities and women.
- c. The Contractor shall actively solicit and shall provide NJ TRANSIT with proof of solicitations for employment, including but not limited to advertisements in general circulation media, professional service publications and electronic media.
- d. The Contractor shall provide evidence of efforts described in b above to NJ TRANSIT no less frequently than once every twelve (12) months.
- e. The Contractor shall comply with the requirements set forth at N.J.A.C. 17:27.

#### 11.2.6 Equal Opportunity for Individuals with Disabilities

The Contractor and NJ TRANSIT agree that the provisions of Title II of the Americans with Disabilities Act of 1990 (the "Act") (42 U.S.C. §12101 et seq.), which prohibit discrimination on the basis of disability by public entities in all services, programs, and activities provided or made available by public entities, and the rules and regulations promulgated thereto, are made a part of this Contract. In providing any aid, benefit, or service on behalf of NJ TRANSIT pursuant to this Contract, the Contractor agrees that the performance shall be in strict compliance with the Act. In the event that the Contractor, its agents, servants, employees, or Subcontractors violate or are alleged to have violated the Act during the performance of this Contract, the Contractor shall defend NJ TRANSIT and the State of New Jersey in any action or administrative proceeding commenced pursuant to this Act. The Contractor shall indemnify, protect, and save harmless NJ TRANSIT and the State, their agents, servants, and employees from and against any and all suits, claims, losses, demands, or damages of whatever kind or nature arising out of or claimed to arise out of the alleged violation. The Contractor shall, at its own expense, appear, defend, and pay any and all charges for legal services and any and all costs and other expenses arising from such action or administrative proceeding or incurred in connection therewith. In any and all complaints brought pursuant to the applicable grievance procedure, the Contractor agrees to abide by any decision rendered pursuant to such grievance procedure. If any action or administrative proceeding results in an award of damages against NJ TRANSIT or the State or if NJ TRANSIT or the State incur any expense to cure a violation of the Act which has been brought pursuant to its grievance procedure, the Contractor shall satisfy and discharge the same at its own expense.

NJ TRANSIT shall, as soon as practicable after a claim has been made against it, give written notice thereof to the Contractor along with full and complete particulars of the claim. If any action or administrative proceeding is brought against NJ TRANSIT or any of its agents, servants, and employees, NJ TRANSIT will forward or have forwarded to the Contractor every demand, complaint, notice, summons, pleading, or other process received by it or its representatives.

It is expressly agreed and understood that any approval by NJ TRANSIT of the services provided by the Contractor pursuant to this Contract will not relieve the Contractor of the obligation to comply with the Act and to defend, indemnify, protect, and save harmless NJ TRANSIT pursuant to this paragraph.

The Contractor expressly understands and agrees that the provisions of this indemnification clause shall in no way limit the Contractor's obligations assumed in this Contract, nor shall they be construed to relieve the Contractor from any liability, nor preclude NJ TRANSIT from taking any other actions available to it under any other provisions of this Contract or otherwise at law.

### 11.3 UTILIZATION OF DISADVANTAGED BUSINESS ENTERPRISES

The term "disadvantaged business enterprise" means a for-profit small business concern that is owned and controlled by one or more socially and economically disadvantaged persons, as defined by 49 C.F.R., Part 26. Such disadvantage may arise from cultural, racial, chronic economic circumstances or background or other similar cause. Such persons would include, but not be limited to, Black Americans (not of Hispanic origin); Hispanic Americans; Native Americans; Asian-Pacific Americans; Subcontinent Asian Americans; and Women, regardless of race or ethnicity.

NJ TRANSIT's DBE Program is accorded the same priority as compliance with all other legal obligations required by the USDOT. Contractors shall comply with the DBE Program requirements in the award and administration of NJ TRANSIT contracts. Failure by the Contractor to carry out these requirements shall constitute a breach of the contract, which may result in the termination of the contract or other such remedy, as NJ TRANSIT deems appropriate.

Should the actual contract amount increase or decrease, through approved change order(s), the Office of Business Development (OBD) must be informed. OBD will determine if this will result in an adjustment to DBE participation to reflect the assigned DBE goal.

The Contractor shall fully comply with the requirements and provisions set forth in the New Jersey Transit Corporation DBE Requirements for Federal Procurement Activities.

**12. MEASUREMENT AND PAYMENT**

**12.1 SCOPE OF PAYMENT**

12.1.1 The Contractor shall receive and accept compensation provided for in the Contract as full payment for furnishing materials and for performing work under the Contract in a complete and acceptable manner and for risk, loss, damage or expense of whatever character arising out of the nature of the work or the prosecution thereof.

12.1.2 If the specifications relating to a unit price in the Proposal require that the said unit price cover and be considered compensation for certain work or material essential to the item, this same work or material will not also be measured or paid for under any other item which may appear elsewhere in the Contract.

12.1.3 If the specifications include Work for which no specific method of payment is provided, no separate payment will be made for that Work and the cost thereof shall be considered as included in the prices paid for the various scheduled Contract Items.

12.1.4 Except as specifically provided otherwise, no separate payment will be made for any of the requirements of the General and Special Provisions, and the cost thereof shall be considered as included in the various scheduled Contract Items.

12.1.5 Notwithstanding any other provision of this Contract, for a period of three years after acceptance, all estimates and payments (including the Final Certificate of Payment and payments made pursuant to the Final Certificate of Payment) shall be subject to correction and adjustment for clerical or other errors in the calculations involved in the determination of quantities and payments. The Contractor and NJ TRANSIT agree to pay to the other any sum due under the provisions of this Article.

**12.2 QUANTITIES: MEASUREMENT AND PAYMENT**

12.2.1 Work completed under the Contract will be measured by the Construction Manager according to United States standard measure. The method of measurement and computations to be used in determination of quantities of material furnished and of work performed under the Contract will be those methods generally recognized as conforming to good engineering practice.

12.2.2 Wherever the estimated quantities of work to be done and materials to be furnished under the Contract are shown in the documents including the proposal, they are given for use in comparing Bids and the right is especially reserved, except as herein otherwise specifically limited, to increase or diminish them as may be deemed reasonably necessary or desirable by NJ TRANSIT to complete the work contemplated by this Contract, and such increase or diminution shall in no way abrogate this Contract, nor shall such increase or diminution give cause for claims or liability for damages.

12.2.3 When the Bidder's Proposal contains itemized quantities which are to be paid on a Unit Price basis, those quantities are designated as the Pay Quantities. When the estimated quantities for a specific portion of the work are designated as the Pay Quantities in the Contract, and if the work is actually performed as specified, they shall be the final quantities for which payment for such specific portion of the work will be made, unless the dimensions of said portions of the work shown on the plans are revised, or unless errors in the quantities are discovered. If revised dimensions result in an increase or decrease in the quantities of such work, the final quantities for payment will be revised in the amount represented by the authorized changes in the dimensions.

12.2.4 Wherever the actual quantity of work performed varies more than twenty-five percent (25%) above or below an estimated quantity shown in the Bidder's Proposal, an equitable adjustment to the contract shall be made upon demand of either NJ TRANSIT or the Contractor. The equitable adjustment shall be based upon an increase or decrease in costs due solely to the twenty-five percent (25%) variation above or below the estimated quantity.

### 12.3 PARTIAL PAYMENTS

12.3.1 Monthly estimates will be made of the approximate quantities of work satisfactorily performed in accordance with the Contract Documents during the preceding month. Partial payments on account of such monthly estimate will be made based on the prices bid or as provided by change order. The Contractor will also be paid under the monthly estimates for materials delivered in accordance with Article 12.4, MATERIALS PAYMENTS and Article 8.2, MEASUREMENT OF PAY LIMITS FOR EXCAVATIONS.

For each lump sum Bid item excluding Performance/Payment Bond, Mobilization and Allowances, the Contractor shall submit for the Construction Manager's review and approval a "Schedule of Values" (a detailed price breakdown of all individual items of work that are contained in said Bid items) within ten (10) calendar days of the Notice to Proceed. The approved Schedule of Values shall be incorporated into each Application for Payment and shall be used by NJ TRANSIT as the basis for partial payment and, if it so elects, as a basis for determining values of work it wishes to modify or delete.

12.3.2 No such estimate or payment shall be required to be made, in the judgment of NJ TRANSIT, when the work is not proceeding in accordance with the Contract Documents or following NJ TRANSIT giving the Contractor or surety notice of delay, neglect or default.

12.3.3 No such estimate or payment shall be construed to be an acceptance of any defective work or improper materials. NJ TRANSIT upon determining that any payment under a previous monthly estimate was improper or unwarranted for any reason may deduct the amount of such payment from the subsequent monthly estimate and partial payments made to the Contractor.

12.3.4 Material and work covered by partial payments made shall thereupon become the sole property of NJ TRANSIT but this provision shall not be construed as relieving the Contractor from the sole responsibility for care and protection of materials and work upon which payments have been made or restoration of any damaged work, or as a waiver of the right of NJ TRANSIT to require fulfillment of terms of the Contract.

12.3.5 NJ TRANSIT shall deduct from any monthly estimate and payment and the final payment such amounts as are required to be deducted pursuant to provisions of the Contract Documents.

12.3.6 In accordance with N.J.S.A. 52:32-40 and 52:32-41, prior to the issuance of a partial payment by NJ TRANSIT to the Contractor, the Contractor shall certify that a Subcontractor or Supplier has been paid any amount due from any previous partial payment and shall be paid any amount due from the current partial payment, or that a valid basis for withholding payment exists and the Contractor has complied with the applicable notice provisions.

#### 12.4 MATERIALS PAYMENTS

12.4.1 The monthly estimates and payments made on account thereof will also include, when allowed by the Project Manager, an amount equal to the actual cost of materials furnished but not incorporated into the work, provided, however, that such amount shall not exceed 85 percent of the Contractor's Bid price for the Contract Item into which the material will be incorporated, and the quantity allowed does not exceed the corresponding quantity estimated in the Contract.

12.4.2 Before including payments for such materials in an estimate, the Construction Manager must be satisfied that:

- (a) The materials have been properly stored and protected by the Contractor or have been stored at locations owned or leased by NJ TRANSIT,
- (b) The materials have been inspected and appear to be acceptable,
- (c) The Contractor has provided NJ TRANSIT an invoice or bill of sale sufficient to show the price paid for the materials and proof that title, if applicable, has been transferred to NJ TRANSIT,
- (d) The materials, if stored on property not belonging to NJ TRANSIT, are fenced in with access limited to NJ TRANSIT and the Contractor or their authorized agents and the fenced in materials are clearly identified in large letters as being without encumbrances and for use solely on this Project, and
- (e) When such materials are stored in a leased area, the lease is made out to the Contractor and provides that it shall be cancelled only with the written permission of NJ TRANSIT.

12.4.3 The Contractor assumes full responsibility for the safe storage and protection of the materials and nothing in this Paragraph shall alter the provisions of Article 9.1, INDEMNIFICATION; RISKS ASSUMED BY THE

CONTRACTOR. If materials paid for under this Article are damaged, stolen or prove to be unacceptable, the payment made therefor shall be deducted from subsequent estimates and payment.

12.4.4 Payment for materials as provided in this Article shall not be deemed to be an acceptance of such materials, and the Contractor shall be responsible for and must deliver to the site and properly incorporate in the work only those materials that comply with the Contract.

12.4.5 No payment for living or perishable plant materials will be made until they are accepted by NJ TRANSIT.

12.4.6 The Contractor shall pay all costs of handling and delivering materials to and from the place of storage to the site of the work, as well as storage rental. Taxes levied by any government against the materials shall be borne by the Contractor.

## 12.5 RETAINAGE

12.5.1 In making partial payments for work, there will be retained by NJ TRANSIT five percent of the estimated amount until completion and final acceptance of all work covered by the Contract and issuance of a Final Certificate of Payment.

12.5.2 The Contractor shall defend, indemnify and save NJ TRANSIT harmless from claims arising out of the demands of Subcontractors, laborers, workmen, mechanics, Suppliers, and furnishers of machinery and parts thereof, equipment, power tools, and supplies, including commissary, incurred in the furtherance of the performance of this Contract. The Contractor shall, at NJ TRANSIT's request, furnish satisfactory evidence that all obligations of the nature herein above designated have been paid, discharged or waived. The retainage specified herein shall not be paid to the Contractor until such obligations have been paid, discharged or waived. Recourse may also be made, if necessary, to the payment bond.

## 12.6 SUBCONTRACTOR PAYMENTS AND RETAINAGE

12.6.1 A Subcontractor shall look only to the Contractor for the payment of any claims of any nature whatsoever arising out of the said subcontract, and said Subcontractor agrees, as a condition of NJ TRANSIT's consent to the making of said subcontract, that it shall make no claim whatsoever against NJ TRANSIT, its officers, agents, servants or employees for any work performed or thing done by reason of said subcontract, or for any other cause whatsoever that may arise by reason of the relationship created between the Contractor and Subcontractor by the subcontract.

12.6.2 Prompt Payment: The Contractor agrees to pay each Subcontractor and Supplier under this Contract for satisfactory performance of completed work under its subcontract no later than ten (10) calendar days from the receipt of each payment the Contractor receives from NJ TRANSIT. The Contractor shall ensure that all lower tier Subcontractors and suppliers are paid all invoiced amounts (less retainage) that meet all



applicable requirements within fifteen (15) calendar days from the time the Subcontractor receives payment from the Contractor.

- 12.6.3 In accordance with N.J.S.A. 52:32-40 and 52.32-41, the Contractor shall certify, prior to the issuance of a progress payment by NJ TRANSIT, that all Subcontractors and Suppliers have been paid any amounts due from previous progress payments and shall be paid any amounts due from the current progress payment. Alternatively, the Contractor shall certify that there exists a valid basis under the terms of the Subcontractor's or Supplier's contract to withhold payment from the Subcontractor or Supplier and therefore payment is withheld.
- 12.6.4 If the Contractor withholds payment from the Subcontractor or Supplier, the Contractor shall provide to the Subcontractor or Supplier written notice thereof. The notice shall detail the reason for withholding payment and state the amount of payment withheld. If a Performance/ Payment Bond has been provided under this Contract, the Contractor shall send a copy of the notice to the Surety providing the bond for the Contractor. A copy of the notice shall also be submitted to NJ TRANSIT with the certification that payments are being withheld.
- 12.6.5 Should the Contractor provide notice and proceed to withhold payment from any Subcontractor or Supplier, NJ TRANSIT may elect, at its sole discretion, to help resolve the dispute. NJ TRANSIT's efforts shall be limited to meeting with the Contractor and the Subcontractor or Supplier and reviewing the relevant facts with both parties. NJ TRANSIT will not act as a decider of fact nor will NJ TRANSIT direct a settlement to the dispute. Any NJ TRANSIT effort is solely intended to assist the parties in understanding their respective positions and to encourage a reasonable resolution of the dispute.
- 12.6.6 The Contractor agrees to make retainage payments to each Subcontractor or Supplier within fifteen (15) calendar days after the Subcontractor's or Supplier's work is completed. Only Subcontractors whose work has been 100% completed, including all Punchlist Work and any other Remaining Work, and who have supplied closeout documents shall be eligible for release of retainage. Any delay or postponement of payment from the above referenced time frame may occur only for good cause following written approval of NJ TRANSIT.
- 12.6.7 NJ TRANSIT agrees to release an equivalent amount of Contractor retainage provided that a) there are no offsetting claims from NJ TRANSIT (including, but not limited to, liquidated damages), other Subcontractors, Suppliers, materialmen or workers, and b) none of the other reasons to withhold payments specified under Article 12.7 exists. Prior to release of the Contractor's retainage, the Contractor shall provide to NJ TRANSIT executed copies of the following Subcontractor Closeout Documents, as appropriate: Consent of Surety to Final Payment to the Subcontractor, Subcontractor's Certificate of Amounts Due Workers For Wages, a Subcontractor Affidavit of Payment of Debts and Claims, a Subcontractor Affidavit of Release of

Liens and a Certificate of Final Acceptance of Subcontractor Work, all in the form shown in Appendix B to the Contract.

12.6.8 Notwithstanding NJ TRANSIT's release or partial release of retainage, nothing in this Article shall be deemed to constitute NJ TRANSIT's partial or final acceptance of the Work, or any portion thereof, unless either a Certificate of Partial Acceptance or a Certificate of Final Acceptance has been executed by NJ TRANSIT, in the form(s) shown in Appendix B to the Contract.

## 12.7 PAYMENTS WITHHELD

12.7.1 NJ TRANSIT may withhold or, on account of subsequently discovered evidence, nullify the whole or a part of a certificate for payment to such extent as may be necessary to protect NJ TRANSIT from loss on account of:

- (1) Defective work not remedied;
- (2) Claims filed, or reasonable evidence indicating probable filing of claims;
- (3) Failure of the Contractor to make payments promptly to Subcontractors or Suppliers for material or labor;
- (4) A reasonable doubt that the Contract can be completed for the balance then unpaid;
- (5) Damage to another contractor;
- (6) Lack of updated and approved CPM schedule;
- (7) Submission of incomplete payment invoice;
- (8) Liquidated damages;
- (9) Previous overpayments; and
- (10) Lack of compliance with Contract terms.

12.7.2 When the above grounds are removed, certificates of payment will be issued for amounts withheld because of them, less appropriate adjustments.

## 12.8 FINAL PAYMENT

12.8.1 Submissions required from the Contractor as a condition of final payment, include, but are not limited to, the following items:

- (1) Completed Operations Insurance Certificate,
- (2) Affidavit of Payment of Debts and Claims,
- (3) Affidavit of Release of Liens,
- (4) Consent of Surety to Final Payment,
- (5) Certificate of amounts due workers for wages on the work pursuant to N.J.S.A. 34:11-56.25 et seq.,

- (6) The one year and special written guarantees for periods of time in excess of the one year general guarantee,
- (7) Operating instructions and maintenance manuals for equipment as required under Article 7.5.3. The maintenance and operating information shall be organized into suitable sets. Where applicable, these include: Operating and emergency instructions, replacement parts listing, maintenance contracts, warranties, guarantees, wiring diagrams, recommended "turn around" cycles, inspection procedures, shop drawings, product data, and similar applicable information for each type of equipment. Each set should be bound in a plastic covered binder. Identification should be printed clearly on both front and spine of each binder, and a complete typewritten index of contents should be provided. These shall be submitted to the Construction Manager for review by the Engineer. Corrections as required shall be made and then five (5) copies submitted in final form to NJ TRANSIT,
- (8) Markup Drawings, as required under Article 6.11,
- (9) Certificate of Final Acceptance,
- (10) Final payment request based on 100 percent completion of the work with all releases, certificates, consents, guarantees, warranties, and other documents, attached as required, including "Consent of Surety", and
- (11) Final Contractor Monthly DBE Payment Report.

12.8.2 The Proposed Final Certificate of Payment will show the total amount payable to the Contractor, including therein an itemization of said amount segregated as to Contract Item quantities, Extra Work and other basis for payment, and shall also show therein all deductions made or to be made for prior payments and as required pursuant to the provisions of the Contract Documents. All prior estimates and payments shall be subject to correction in the Proposed Final Certificate of Payment. Within thirty (30) calendar days after said Proposed Final Certificate of Payment has been issued to the Contractor, the Contractor shall submit to the Construction Manager its written approval of said Final Certificate of Payment or a written statement of all outstanding Contractor Initiated Change Order Requests (CICOR's) it has arising under or by virtue of the Contract or any action by any NJ TRANSIT employee, agent or officer in the prosecution of the Contract. CICOR's will not be considered unless the Contractor has strictly complied with the requirements of Article 3.4 - CONTRACTOR INITIATED CHANGE ORDERS.

12.8.3 On the Contractor's approval, or if it files no statement of outstanding CICOR's within said period of thirty (30) calendar days, the Contracting Officer will issue a Final Certificate of Payment in writing in accordance with the proposed Final Certificate of Payment submitted to the Contractor and within thirty (30) calendar days thereafter, NJ TRANSIT will pay the entire sum due thereunder. Such Final Certificate of Payment and acceptance by the Contractor of the Final Payment based thereon shall operate as a release by the Contractor of the State and NJ TRANSIT, their agents, officers and employees, from all claims and liability of whatsoever nature for anything done or furnished or in any manner growing out of the performance of the Contract.

- 12.8.4 If the Contractor within said period of thirty (30) calendar days files a statement of outstanding CICOR's, the Contracting Officer will issue a Conditional Final Certificate of Payment in accordance with the proposed Final Certificate of Payment. Within thirty (30) calendar days thereafter, NJ TRANSIT will pay the sum due there under, provided the Contractor has in good faith provided the detailed CICOR cost information required by Article 3.4. The Contractor may request up to an additional thirty (30) calendar days within which to provide the required information.
- 12.8.5 Failure to submit such detailed cost information as to any CICOR within the sixty (60) calendar days provided from the date of the issuance of the proposed Final Certificate of Payment shall operate as a waiver of those CICOR's as to which such information is not provided and a release by the Contractor in favor of the State and NJ TRANSIT as to such CICOR. NJ TRANSIT will then issue a Conditional Final Payment based on the Conditional Final Certificate. Acceptance by the Contractor of this Conditional Final Payment shall constitute a release by the Contractor of the State and NJ TRANSIT, their agents, officers and employees, from all claims and liability of whatsoever nature for anything done or furnished or in any manner growing out of the performance of the Contract except those CICOR's filed in response to the proposed Final Certificate and not waived as herein provided for failure to provide information and details.
- 12.8.6 The Contracting Officer's decision on outstanding CICOR's will be rendered in accordance with Article 1.15-DISPUTES.
- 12.8.7 Upon final resolution of the outstanding CICOR's, the Contracting Officer shall then make and issue a Final Certificate of Payment, and within thirty (30) calendar days thereafter, NJ TRANSIT will pay the entire sum, if any, found due thereon. Such Final Payment, if it resolves any of the CICOR's reserved under the Conditional Final Payment, will operate as a release in favor of the State, and NJ TRANSIT, their agents, officers and employees as to such claims.
- 12.8.8 No payment, however, final or otherwise, shall operate to release the Contractor or its Sureties from any obligations under this Contract or the Performance and Payment Bond.
- 12.9 SETTING OFF TAX ARREARS AGAINST SUMS OWED
- Whenever any taxpayer under contract to provide goods or services to the State of New Jersey or its agencies or instrumentalities, and including the legislative and judicial branches of State government, or under contract for construction projects of the State of New Jersey or its agencies or instrumentalities, and including the legislative and judicial branches of State government, is entitled to payment for the goods or services or on that construction project and at the same time the taxpayer is indebted for any State tax, the Director of the Division of Taxation shall seek to set off so much of that payment as shall be necessary to satisfy the indebtedness. The Director, in consultation with the Director of the Division of Budget and Accounting in the Department of the Treasury, shall establish procedures and methods to effect a set-off. The Director shall give notice of the set-off to the taxpayer, the provider of goods or services or the

Contractor or Subcontractor of construction projects and provide an opportunity for a hearing within thirty (30) calendar days of such notice under the procedures for protests established under N.J.S.A.54:49-18, but no request for conference, protest, or subsequent appeal to the Tax Court from any protest under this section shall stay the collection of the indebtedness. No payment shall be made to the taxpayer, the provider of goods or services or the Contractor or Subcontractor of construction projects pending resolution of the indebtedness. Interest that may be payable by the State pursuant to N.J.S.A.52:32-32 et seq., to the taxpayer, the provider of goods and services or the Contractor or Subcontractor of construction projects shall be stayed.

### **13. ACCEPTANCE AND COMPLETION**

#### **13.1 PARTIAL ACCEPTANCE**

If at any time during the prosecution of the Project the Contractor completes a unit or portion of the Project, such as a structure or a section of right-of-way, it may request that NJ TRANSIT make a final inspection of that unit. NJ TRANSIT reserves the right to reject the request made by the Contractor if NJ TRANSIT, in its sole discretion, determines that the unit or portion of the project should not be the subject of a Partial Acceptance.

If NJ TRANSIT determines that Partial Acceptance of the unit or portion of the Project is appropriate and finds upon inspection that the unit or portion is satisfactorily completed in compliance with the Contract, the Project Manager may accept that unit as being completed and the Contractor may be relieved of the responsibility of doing further work on or maintaining that unit or portion of the Project.

Such Partial Acceptance shall in no way void or alter the terms of the Contract, including Articles 9.1- INDEMNIFICATION; RISKS ASSUMED BY THE CONTRACTOR and 9.2- INSURANCE, nor shall it be construed as relieving the Contractor of full responsibility for making good defective work or materials found at any time before Final Acceptance pursuant to Article 13.3- COMPLETION AND FINAL ACCEPTANCE OF THE WORK.

#### **13.2 SUBSTANTIAL COMPLETION**

**13.2.1** The Work shall be deemed substantially complete when, in the opinion of the Project Manager (whose judgment shall be conclusive), so much thereof has been completed in accordance with the terms of the Contract Documents that NJ TRANSIT may occupy the site of the work and use the work and the facilities resulting therefrom for the purposes for which they are intended. Unless the Project Manager determines that temporary pavement is sufficient, substantial completion will not be deemed to have occurred prior to the backfilling and restoration of street surfaces (if any) and the restoration of other surfaces, subsurfaces and overhead structures. Upon such substantial completion the Project Manager shall issue a Certificate of Substantial Completion. The issuance of this Certificate shall not relieve the Contractor from its obligation hereunder to finally complete all of the work of the Contract.

13.2.2 The work remaining to be completed after substantial completion in order for the Contractor to fulfill its obligations to fully complete the Work in accordance with the Contract shall be known as the "Remaining Work". The Remaining Work shall generally be limited to minor defects or omissions (also known as "Punch List Work"). However, NJ TRANSIT may include as part of Remaining Work, work which would ordinarily be required for substantial completion. Such other Remaining Work includes, but is not limited to, work not done because of seasonal factors or work which cannot be done until third persons perform other work which is not the Contractor's responsibility under the Contract. Nothing herein, however, shall diminish the right of NJ TRANSIT to determine what is necessary for substantial completion in accordance with Sub-article 13.2.1 above.

13.2.3 NJ TRANSIT shall advise the Contractor of the time required to complete Punch List Work and the time required to complete all other Remaining Work. Failure to complete in a timely manner all Remaining Work, other than Punch List Work, will result in the Contractor being liable for liquidated damages as set forth in Article 2.1, TIME OF COMPLETION - DELAY - LIQUIDATED DAMAGES. As an additional remedy for such failure, and not in lieu of liquidated damages, NJ TRANSIT may complete the Remaining Work including Punch List Work, either by its own forces or by other contractors. The Contractor shall be entitled to payment according to the Contract Price upon such completion, subject however to NJ TRANSIT's right to reimbursement for its costs of completion. NJ TRANSIT may deduct such costs from any payment or payments due to the Contractor, and if such costs exceed the amount due the Contractor, the Contractor shall promptly pay such excess to NJ TRANSIT. NJ TRANSIT's entitlement to such reimbursement shall in no respect relieve the Contractor of its obligation to timely complete the Remaining Work.

13.2.4 Before final inspection, completion and acceptance of the Project, borrow and local material sources and areas occupied by the Contractor in connection with the work shall be cleaned of rubbish, excess materials, temporary structures and equipment, and the work shall be left in an acceptable condition. The final inspection and acceptance will not be made by NJ TRANSIT until the Project has been completed, including all work identified as "Remaining Work" (Punch List Work).

### 13.3 COMPLETION AND FINAL ACCEPTANCE OF THE WORK

13.3.1 When the Contractor believes that the Project has been fully completed, the Contractor shall provide written notification to the Construction Manager that the Project is ready for final inspection by NJ TRANSIT.

If the Project Manager finds the Work to be in compliance with the Contract, it will notify the Contracting Officer establishing completion as of the date of notification from the Contractor. If the Contracting Officer concurs, the Contractor will be issued a Certificate of Final Acceptance.

If the Project Manager's inspection discloses that the Work is not in conformance with the Contract, the Construction Manager will advise the Contractor as to the particular defects to be remedied. Upon correction of the defects, the Contractor shall provide written notification to the Construction Manager and

another inspection shall be made. This procedure shall be repeated until the Project Manager finds the work to be in compliance with the Contract.

Payments made to the Contractor before the final acceptance do not commit NJ TRANSIT to acceptance of the Project.

13.3.2 NJ TRANSIT shall not be precluded or estopped, by any measurement, estimate or certificate made either before or after the completion and final acceptance of the Project and payment therefor if such measurement, estimate or certificate is found to be in error or untrue, from showing the true amount and character of the work performed and materials furnished by the Contractor, or from showing that any such measurement, estimate or certificate is incorrectly made or untrue, or that the work or materials do not conform in fact to the requirements of the Contract. NJ TRANSIT shall not be precluded or estopped, notwithstanding any such measurement, estimate or certificate, and payment made in accordance therewith, from recovering from the Contractor and its Surety such damages as it may sustain by reason of the Contractor's failure to comply or to have complied with the terms of the Contract.

13.3.3 The Contractor, without prejudice to the terms of the Contract, shall be liable to NJ TRANSIT at any time both before and after acceptance for latent defects, fraud, or such gross mistakes as may amount to fraud, or as regards NJ TRANSIT's rights under any warranty or guarantee.

#### **14. FEDERAL PROVISIONS**

##### **14.1 EMPLOYEE PROTECTIONS-CONSTRUCTION ACTIVITIES**

The Contractor agrees to comply, and assures the compliance by each Subcontractor at any tier, with the following employee protection requirements for construction employees:

1. Davis-Bacon Act, as amended, 49 U.S.C. § 5333(a), the Davis-Bacon Act, 40 U.S.C. §§ 276a-276a(7), and U.S. DOL regulations, "Labor Standards Provisions Applicable to Contracts Governing Federally Financed and Assisted Construction", 29 C.F.R. Part 5, and 29 C.F.R. Parts 1 & 3.
2. Contract Work Hours and Safety Standards Act, as amended, in particular with the requirements of section 102 of the Act, 40 U.S.C. §§ 327-332; and U.S. DOL regulations, "Labor Standards Provisions Applicable to Contracts Governing Federally Financed and Assisted Construction", 29 C.F.R. Part 5; and with section 107 of the Act, 40 U.S.C. S 333, and U.S. DOL regulations, "Safety and Health Regulations for Construction", 29 C.F.R. Part 1926;
3. Copeland "Anti-Kickback" Act, as amended, 18 U.S.C. § 874 and 40 U.S.C. S 276c, and U.S. DOL regulations, "Contractors and Subcontractors on Public Building or Public Work Financed in Whole or in part by Loans or Grants from the United States", 29 C.F.R. Part 3.

#### 14.1.1 MINIMUM WAGES

The Contractor shall comply with the following labor provisions. Should wage rates determined in accordance with the following conflict with those determined in accordance with Article 11.1, New Jersey Prevailing Wage Act, the greater of the two rates apply.

- (a) All laborers and mechanics employed or working upon the site of the work (or under the United States Housing Act of 1937 or under the Housing Act of 1949 in the Construction or Development of the Project), will be paid unconditionally and not less often than once a week, and without subsequent deduction or rebate on any account (except such payroll deductions as are permitted by regulations issued by the Secretary of Labor under the Copeland Act, 29 C.F.R. Part 3), the full amount of wages and bona fide fringe benefits (or cash equivalents thereof) due at the time of payment computed at rates not less than those contained in the wage determination of the Secretary of Labor which is attached hereto and made a part hereof, regardless of any contractual relationship which may be alleged to exist between the Contractor and such laborers and mechanics.

Contributions made or costs reasonably anticipated for bona fide fringe benefits under Section 1(b)(2) of the Davis-Bacon Act on behalf of laborers or mechanics are considered wages paid to such laborers or mechanics, subject to the provisions of 29 C.F.R. Part 5.5(a)(1)(iv); also, regular contributions made or costs incurred for more than a weekly period (but not less often than quarterly) under plans, funds, or programs that cover the particular weekly period, are deemed to be constructively made or incurred during such weekly period. Such laborers and mechanics shall be paid the appropriate wage rate and fringe benefits on the wage determination for the classification of work actually performed, without regard to skill, except as provided at 29 C.F.R. Part 5.5(a)(4). Laborers or mechanics performing work in more than one classification may be compensated at the rate specified for each classification for the time actually worked therein: provided, that the employer's payroll records accurately set forth the time spent in each classification in which work is performed. The wage determination (including any additional classification and wage rates conformed 29 C.F.R. Part 5.5(a)(1)(ii) of this section) and the Davis-Bacon poster (WH-1321) shall be posted at all times by the Contractor and its Subcontractors at the site of the work in a prominent and accessible place where it can be easily seen by the workers.

- (b) 1. The Contracting Officer shall require that any class of laborers or mechanics, including helpers, which is not listed in the wage determination and which is to be employed under the Contract shall be classified in conformance with the wage determination. The Contracting Officer shall approve an additional classification and wage rate and fringe benefits therefore only when the following criteria have been met:



- (a) The work to be performed by the classification requested is not performed by a classification in the wage determination; and
  - (b) The classification is utilized in the area by the construction industry; and
  - (c) The proposed wage rate, including any bona fide fringe benefits, bears a reasonable relationship to the wage rates contained in the wage determination.
  
- 2. If the Contractor and the laborers and mechanics to be employed in the classification (if known), or their representatives, and the Contracting Officer agree on the classification and wage rate (including the amount designated for fringe benefits where appropriate), a report of the action taken shall be sent by the Contracting Officer to the Administrator of the Wage and Hour Division, Employment Standards Administration, U.S. Department of Labor, Washington, DC 20210. The Administrator, or an authorized representative, will approve, modify, or disapprove every additional classification action within thirty (30) calendar days of receipt and so advise the Contracting Officer or will notify the Contracting Officer within the thirty (30) day period that additional time is necessary.
  
- 3. In the event the Contractor, the laborers or mechanics to be employed in the classification or their representatives, and the Contracting Officer do not agree on the proposed classification and wage rate (including the amount designated for fringe benefits, where appropriate), the Contracting Officer shall refer the questions, including the views of all interested parties and the recommendation of the Contracting Officer, to the Administrator for determination. The Administrator, or an authorized representative, will issue a determination within thirty (30) calendar days of receipt and so advise the Contracting Officer or will notify the Contracting Officer within the 30-day period that additional time is necessary.
  
- 4. The wage rate (including fringe benefits where appropriate) determined pursuant to 29 C.F.R. Part 5.5 shall be paid to all workers performing work in the classification under this Contract from the first day on which work is performed in the classification.
  
- (c) Whenever the minimum wage rate prescribed in the Contract for a class of laborers or mechanics includes a fringe benefit which is not expressed as a hourly rate, the Contractor shall either pay the benefit as stated in the wage determination or shall pay another bona fide fringe benefit or an hourly cash equivalent thereof.
  
- (d) If the Contractor does not make payments to a trustee or other third person, the Contractor may consider as part of the wages of any laborer or mechanic the amount of any costs reasonably anticipated in providing bona fide fringe benefits under a plan or program, provided, that the Secretary of Labor has found, upon the written request of the Contractor, that the applicable

standards of the Davis-Bacon Act have been met. The Secretary of Labor may require the Contractor to set aside in a separate account assets for the meeting of obligations under the plan or program.

#### 14.1.2 WITHHOLDING

FTA shall upon its own action or upon written request of an authorized representative of the Department of Labor withhold or cause to be withheld from the Contractor under this Contract or any other Federal contract with the same prime contractor, or any other federally-assisted contract subject to Davis-Bacon prevailing wage requirements, which is held by the same prime Contractor, so much of the accrued payments or advances as may be considered necessary to pay laborers and mechanics, including apprentices, trainees, and helpers, employed by the Contractor or any Subcontractor the full amount of wages required by the Contract. In the event of failure to pay any laborer or mechanic, including any apprentice, trainee, or helper, employed or working on the site of the work (or under the United States Housing Act of 1937 or under the Housing Act of 1949 in the Construction or Development of the Project), all or part of the wages required by the contract, FTA may, after written notice to the Contractor, sponsor, applicant or owner, take such action as may be necessary to cause the suspension of any further payment, advance, or guarantee of funds until such violations have ceased.

#### 14.1.3 PAYROLLS AND BASIC RECORDS

(a) Payrolls and basic records relating thereto shall be maintained by the Contractor during the course of the work and preserved for a period of three years thereafter for all laborers and mechanics working at the site of the work (or under the United States Housing Act of 1937, or under the Housing Act of 1949, in the Construction or Development of the Project). Such records shall contain the name, address, and social security number of each such worker, his or her correct classification, hourly rates of wages paid (including rates of contributions or costs anticipated for bona fide fringe benefits or cash equivalents thereof of the types described in Section 1(b)(2)(B) of the Davis-Bacon Act), daily and weekly number of hours worked, deductions made and actual wages paid. Whenever the Secretary of Labor has found under 29 C.F.R. Part 5.5(a)(1)(iv) that the wages of any laborer or mechanic include the amount of any costs reasonably anticipated in providing benefits under a plan or program described in Section 1(b)(2)(B) of the Davis-Bacon Act, the Contractor shall maintain records which show that the commitment to provide such benefits is enforceable, that the plan or program is financially responsible, and that the plan or program has been communicated in writing to the laborers or mechanics affected, and records which show the costs anticipated or the actual costs incurred in providing such benefits. Contractors employing apprentices or trainees under approved programs shall maintain written evidence of the registration of apprenticeship programs and certification of trainee programs, the registration of the apprentices and trainees, and the ratios and wage rates prescribed in the applicable programs.

- (b) 1. The Contractor shall submit weekly for each week in which any contract work is performed a copy of all payrolls to the FTA if the agency is a party to the contract, but if the agency is not such a party, the Contractor shall submit the payrolls to the applicant, sponsor, or owner, as the case may be, for transmission to the FTA. The payrolls submitted shall set out accurately and completely all of the information required to be maintained under 29 C.F.R. Part 5.5(a)(3)(i), except that full social security numbers and home addresses shall not be included on weekly transmittals. Instead the payrolls shall only need to include an individually identifying number for each employee (e.g., the last four digits of the employee's social security number). The required weekly payroll information may be submitted in any form desired. Optional Form WH-347 is available for this purpose from the Wage and Hour Division Web site at <http://www.dol.gov/esa/whd/forms/wh347instr.htm> or its successor site. The Contractor is responsible for the submission of copies of payrolls by all Subcontractors. Contractors and Subcontractors shall maintain the full social security number and current address of each covered worker, and shall provide them upon request to the FTA if the agency is a party to the contract, but if the agency is not such a party, the Contractor shall submit them to NJ TRANSIT for transmission to the FTA, the Contractor, or the Wage and Hour Division of the United States Department of Labor for purposes of an investigation or audit of compliance with prevailing wage requirements. It is not a violation of 29 C.F.R. Part 5.5(a)(3) for a contractor to require a Subcontractor to provide addresses and social security numbers to the Contractor for its own records, without weekly submission to the sponsoring government agency (or the applicant, sponsor, or owner).
2. Each payroll submitted shall be accompanied by "Statement of Compliance", signed by the Contractor or Subcontractor or his or her agent who pays or supervises the payment of the persons employed under the Contract and shall certify the following:
- (a) That the payroll for the payroll period contains the information required to be provided under 29 C.F.R. Part 5.5 (a)(3)(ii), the appropriate information is being maintained under 29 C.F.R. Part 5.5 (a)(3)(i) and that such information is correct and complete;
  - (b) That each laborer or mechanic (including each helper, apprentice, and trainee) employed on the Contract during the payroll period has been paid the full weekly wages earned, without rebate, either directly or indirectly, and that no deductions have been made either directly or indirectly from the full wages earned, other than permissible deductions as set forth at 29 C.F.R. Part 3;
  - (c) That each laborer or mechanic has been paid not less than the applicable wage rates and fringe benefits or cash equivalents for the classification of work performed, as specified in the applicable wage determination incorporated into the contract.

3. The weekly submission of a properly executed certification set forth on the reverse side of optional form WH-347 shall satisfy the requirement for submission of the "Statement of Compliance" required by 29 C.F.R. Part 5.5(a)(3)(ii)(B).
  4. The falsification of any of the above certifications may subject the Contractor or Subcontractor to civil or criminal prosecution under 18 U.S.C. 1001 and 31 U.S.C. 231.
- (c) The Contractor or Subcontractor shall make the records required under 29 C.F.R. Part 5.5(a)(3)(i) available for inspection, copying, or transcription by authorized representatives of FTA or the Department of Labor, and shall permit such representatives to interview employees during working hours on the job. If the Contractor or Subcontractor fails to submit the required records or make them available, FTA may, after written notice to the Contractor, sponsor, applicant, or owner, take such action as may be necessary to cause the suspension of any further payment, advance, or guarantee of funds. Furthermore, failure to submit the required records upon request or make such records available may be grounds for debarment action pursuant to 29 C.F.R. Part 5.12.

#### 14.1.4 APPRENTICES AND TRAINEES

- (a) Apprentices - Apprentices will be permitted to work at less than the predetermined rate for the work they performed when they are employed pursuant to and individually registered in a bona fide apprenticeship program registered with the U.S. Department of Labor, Employment and Training Administration, Office of Apprenticeship Training, Employer and Labor Services, or with a State Apprenticeship Agency recognized by the Office, or if a person is employed in his or her first ninety (90) calendar days of probationary employment as an apprentice in such an apprenticeship program, who is not individually registered in the program, but who has been certified by the Office of Apprenticeship Training, Employer and Labor Services, or a State Apprenticeship Agency (where appropriate) to be eligible for probationary employment as an apprentice. The allowable ratio of apprentices to journeymen on the job site in any craft classification shall not be greater than the ratio permitted to the Contractor as to the entire work force under the registered program. Any worker listed on a payroll at an apprentice wage rate, who is not registered or otherwise employed as stated above, shall be paid not less than the applicable wage rate on the wage determination for the classification of work actually performed. In addition, any apprentice performing work on the job site in excess of the ratio permitted under the registered program shall be paid not less than the applicable wage rate on the wage determination for the work actually performed. Where a Contractor is performing construction on a project in a locality other than that in which its program is registered, the ratios and wage rates (expressed in percentages of the journeyman's hourly rate) specified in the Contractor's or Subcontractor's registered program shall be observed. Every apprentice must be paid at not less than the rate specified in the registered program for the apprentice's level of progress, expressed as a percentage of the journeyman hourly rate specified in the applicable wage determination. Apprentices shall be paid fringe

benefits in accordance with the provisions of the apprenticeship program. If the apprenticeship program does not specify fringe benefits, apprentices must be paid the full amount of fringe benefits listed on the wage determination for the applicable classification. If the Administrator determines that a different practice prevails for the applicable apprentice classification, fringes shall be paid in accordance with that determination. In the event the Office of Apprenticeship Training, Employer and Labor Services, or a State apprenticeship agency recognized by the Office, withdraws approval of an apprenticeship program, the Contractor will no longer be permitted to utilize apprentices at less than the applicable predetermined rate for the work performed until an acceptable program is approved.

- (b) Trainees - Except as provided in 29 C.F.R. Part 5.16, trainees will not be permitted to work at less than the predetermined rate for the work performed unless they are employed pursuant to and individually registered in a program which has received prior approval, evidenced by formal certification by the U.S. Department of Labor, Employment and Training Administration. The ratio of trainees to journeymen on the job site shall not be greater than permitted under the plan approved by the Employment and Training Administration. Every trainee must be paid at not less than the rate specified in the approved program for the trainee's level of progress, expressed as a percentage of the journeyman hourly rate specified in the applicable wage determination. Trainees shall be paid fringe benefits in accordance with the provisions of the trainee program. If the trainee program does not mention fringe benefits, trainees shall be paid the full amount of fringe benefits listed on the wage determination unless the Administrator of the Wage and Hour Division determines that there is an apprenticeship program associated with the corresponding journeyman wage rate on the wage determination which provides for less than full fringe benefits for apprentices. Any employee listed on the payroll at a trainee rate who is not registered and participating in a training plan approved by the Employment and Training Administration shall be paid not less than the applicable wage rate on the wage determination for the classification of work actually performed. In addition, any trainee performing work on the job site in excess of the ratio permitted under the registered program shall be paid not less than the applicable wage rate on the wage determination for the work actually performed. In the event the Employment and Training Administration withdraws approval of a training program, the Contractor will no longer be permitted to utilize trainees at less than the applicable predetermined rate for the work performed until an acceptable program is approved.
- (c) Equal Employment Opportunity - The utilization of apprentices, trainees, and journeymen under 29 C.F.R. Part 5 shall be in conformity with the Equal Employment Opportunity requirements of Executive Order 11246, as amended, and 29 C.F.R. Part 30.

14.1.5 COMPLIANCE WITH COPELAND ACT REQUIREMENTS

The Contractor shall comply with the requirements of 29 C.F.R. Part 3, which are incorporated herein by reference.

14.1.6 CONTRACT TERMINATION: DEBARMENT

A breach of the Contract clauses in 29 C.F.R. Part 5.5 may be grounds for termination of the contract, and for debarment as a Contractor and a Subcontractor as provided in 29 C.F.R. Part 5.12.

14.1.7 COMPLIANCE WITH DAVIS-BACON AND RELATED ACT REQUIREMENTS

All rulings and interpretations of the Davis-Bacon and related acts contained in 29 C.F.R. Parts 1, 3, and 5 are incorporated herein by reference.

14.1.8 DISPUTES CONCERNING LABOR STANDARDS

Disputes arising out of the labor standards provisions of this Contract shall not be subject to the general disputes clause of this Contract. Such disputes shall be resolved in accordance with the procedures of the Department of Labor set forth in 29 C.F.R. Parts 5, 6, and 7. Disputes within the meaning of this clause include disputes between the Contractor (or any of its Subcontractors) and NJ TRANSIT, the U.S. Department of Labor, or the employees or their representatives.

14.1.9 CERTIFICATION OF ELIGIBILITY

- (a) By entering into this Contract, the Contractor certifies that neither it (nor he nor she) nor any person or firm that has an interest in the Contractor's firm is a person or firm ineligible to be awarded government contracts by virtue of Section 3(a) of the Davis-Bacon Act or 29 C.F.R. Part 5.12(a)(1).
- (b) No part of this Contract shall be subcontracted to any person or firm ineligible for award of a government contract by virtue of Section 3(a) of the Davis-Bacon Act or 29 C.F.R. Part 5.12(a)(1).
- (c) The penalty for making false statements is prescribed in the U.S. Criminal Code, 18 U.S.C. 1001.

14.1.10 OVERTIME REQUIREMENTS

No Contractor or Subcontractor contracting for any part of the contract work which may require or involve the employment of laborers or mechanics shall require or permit any such laborer or mechanic in any work week in which he or she is employed on such work to work in excess of forty hours in such work week unless such laborer or mechanic receives compensation at a rate not less than one and one-half times the basic rate of pay for all hours worked in excess of forty hours in such work week.

14.1.11 VIOLATION; LIABILITY FOR UNPAID WAGES; LIQUIDATED DAMAGES

In the event of any violation of the requirements of 29 C.F.R. Part 5.5(b)(1), the Contractor and any Subcontractor responsible therefor shall be liable for the unpaid wages. In addition, such Contractor and Subcontractor shall be liable to the United States (in the case of work done under contract for the District of Columbia or a territory, to such District or to such territory) for liquidated damages. Such liquidated damages shall be computed with respect to each individual laborer or mechanic, including watchmen and guards, employed in violation of 29 C.F.R. Part 5.5(b)(1) in the sum of \$25 for each calendar day on which such individual was required or permitted to work in excess of the standard work week of forty hours without payment of the overtime wages required by 29 C.F.R. Part 5.5(b)(1).

14.1.12 WITHHOLDING FOR UNPAID WAGES AND LIQUIDATED DAMAGES

FTA or NJ TRANSIT shall upon its own action or upon written request of an authorized representative of the Department of Labor withhold or cause to be withheld, from any moneys payable on account of work performed by the Contractor or Subcontractor under any such contract or any other Federal contract with the same prime Contractor, or any other Federally-assisted contract subject to the Contract Work Hours and Safety Standards Act, which is held by the same prime Contractor, such sums as may be determined to be necessary to satisfy any liabilities of such Contractor or Subcontractor for unpaid wages and liquidated damages as provided in the clause set forth at 29 C.F.R. Part 5.5(b)(2).

14.1.13 SUBCONTRACTS

The Contractor or Subcontractor shall insert in any subcontracts the clauses set forth in this Article 14.1 and also a clause requiring the Subcontractors to include these clauses in any lower tier subcontracts. The prime Contractor shall be responsible for compliance by any Subcontractor or lower tier Subcontractor with the clauses set forth in this Article 14.1.

14.2 CLEAN WATER AND CLEAN AIR ACTS

14.2.1 The Contractor shall comply with all applicable standards, orders, or regulations issued pursuant to the Federal Water Pollution Control Act, as amended, 33 U.S.C. § 1251 et seq.;

(a) With the notification of violating facilities provisions of Executive Order No. 11738; "Administration of the Clean Air Act and the Federal Water Pollution Control Act with Respect to Federal Contracts, Grants, or Loans", 42 U.S.C. S 7606 note. The Contractor agrees to report each violation to NJ TRANSIT and understands and agrees that NJ TRANSIT will, in turn, report each violation as required to assure notification to FTA and the appropriate EPA Regional Office.

(b) With the provisions of the Safe Drinking Water Act of 1974, as amended, 42 U.S.C. § 300h et seq.

14.2.2 The Contractor agrees to comply with all applicable regulations, standards, orders or regulations issued pursuant to the Clean Air Act, as amended, 42 U.S.C. § 7401 et seq. The Contractor agrees to report each violation to NJ TRANSIT and understands and agrees that NJ TRANSIT will, in turn, report each violation as required to assure notification to FTA and the appropriate EPA Regional Office.

14.2.3 The Contractor agrees to include both the Clean Water and Clean Air requirements in each subcontract exceeding \$100,000. The \$100,000 limit includes indefinite quantities where the amount is expected to exceed this limit in any year.

#### 14.3 BUY AMERICA

Pursuant to 49 U.S.C. 5323(j) (P.L. 106-274), and the regulation found at 49 C.F.R. Part 661, the Contractor agrees that all iron, steel and manufactured products purchased or used as a result of this Contract shall be of domestic manufacture or origin unless a waiver of these provisions is granted by the U.S. Secretary of Transportation.

There are four exceptions to this requirement:

- (a) That its application would be inconsistent with the public interest.
- (b) That such materials or products are not produced in the United States in sufficient and reasonably available quantities and of a satisfactory quality.
- (c) With respect to rolling stock only, but including train control, communications, traction power equipment, 40 percent may be non-domestic manufacture, but final assembly of such products must take place in the United States.
- (d) That inclusion of domestic material will increase the cost of the overall project contract by more than 25 percent.

#### 14.4 FLY AMERICA REQUIREMENTS

The Contractor agrees to comply with 49 U.S.C. 40118 (the "Fly America" Act) in accordance with the General Services Administration's regulations at 41 C.F.R. Part 301-10, which provide that recipients and subrecipients of Federal funds and their Contractors are required to use U.S. Flag air carriers for U.S. Government-financed international air travel and transportation of their personal effects or property, to the extent such service is available, unless travel by foreign air carrier is a matter of necessity, as defined by the Fly America Act. The Contractor shall submit, if a foreign air carrier was used, an appropriate certification or memorandum adequately explaining why service by a U.S. flag air carrier was not available or why it was necessary to use a foreign air carrier and shall, in any event, provide a certificate of compliance with the Fly America requirements. The Contractor agrees to include the requirements of this section in all subcontracts that may involve international air transportation.

#### 14.5 CARGO PREFERENCE - USE OF U.S. FLAG VESSELS

The Contractor agrees to utilize privately owned United States-flag commercial vessels to ship at least 50 percent of the gross tonnage (computed separately for dry bulk carriers, dry cargo liners, and tankers) involved, whenever shipping any equipment, materials, or commodities pursuant to 46 C.F.R. Part 381.7(b), to the extent such vessels are available at fair and reasonable rates for United States-flag commercial vessels.



The Contractor further agrees to furnish within twenty (20) working days following the date of loading for shipments originating within the United States, or within thirty (30) working days following the date of loading for shipment originating outside the United States, a legible copy of a rated "on-board" commercial ocean bill-of-lading in English for each shipment of cargo described in the Paragraph above to NJ TRANSIT (through the prime Contractor in the case of Subcontractor bills-of-lading) and to the Division of National Cargo, Office of Market Development, Maritime Administration, Washington, D.C. 20590, marked with appropriate identification of the Project pursuant to 46 C.F.R. Part 381.7(b).

The Contractor further agrees to insert the substance of the provisions of this clause in all subcontracts issued pursuant to this Contract.

14.6 ENERGY CONSERVATION

The Contractor shall comply with mandatory standards and policies relating to energy efficiency contained in applicable State of New Jersey energy conservation plans issued in compliance with the Energy Policy and Conservation Act (42 U.S.C. 6321 et seq.).

14.7 CONTRACT WORK HOURS AND SAFETY STANDARDS

Each Contractor shall be required to compute the wages of every mechanic and laborer on the basis of a standard work day of eight (8) hours and a standard work week of forty (40) hours. Work in excess of a work day or work week is permissible provided that the worker is compensated at a rate of not less than one and one half (1½) times the basic rate of pay for all hours worked in excess of eight (8) hours of any calendar day or forty (40) hours in the work week. No laborer or mechanic shall be required to work in surroundings or under working conditions which are unsanitary, hazardous or dangerous to his/her health and safety. The foregoing provisions are to be in compliance with Section 103 and 107 of the Contract Work Hours and Safety Standards Act (40 U.S.C. 327-330) as supplemented by Department of Labor Regulations (29 C.F.R. Part 5).

14.8 CIVIL RIGHTS

During the performance of this Contract, the Contractor, for itself, its assignees and successors in interest and its Subcontractors at every tier (hereinafter referred to as the "Contractor") agrees as follows:

(a) Compliance with Regulations

The Contractor shall comply with the Regulations relative to nondiscrimination in federally-assisted programs of the United States Department of Transportation, Title 49, Code of Federal Regulations, Part 21, as they may be amended from time to time (hereinafter referred to as the Regulations), which are herein incorporated by reference and made a part of this Contract.

(b) Nondiscrimination

In accordance with Title VI of the Civil Rights Act, as amended, 42 U.S.C. § 2000d, section 303 of the Age Discrimination Act of 1975, as amended, 42 U.S.C. § 6102, section 202 of the Americans with Disabilities Act of 1990, 42 U.S.C. § 12132, Federal transit law at 49 U.S.C. § 5332, and N.J.S.A. 10:3-1, the Contractor agrees that it will not discriminate against any employee or applicant for employment because of race, color, religion, national origin, sex, age, or disability. In addition, the Contractor agrees to comply with applicable Federal implementing regulations and other implementing requirements FTA may issue.

(c) Equal Employment Opportunity

The following equal employment opportunity requirements apply to the underlying contract:

(1) Race, Color, Religion, National Origin, Sex In accordance with Title VI of the Civil Rights Act, as amended, 42 U.S.C. § 2000e, and Federal transit laws at 49 U.S.C. § 5332, the Contractor agrees to comply with all applicable equal employment opportunity requirements of U.S. Department of Labor (U.S. DOL) regulations, "Office of Federal Contract Compliance Programs, Equal Employment Opportunity, Department of Labor," 41 C.F.R. Parts 60 et seq., (which implement Executive Order No. 11246, "Equal Employment Opportunity," as amended by Executive Order No. 11375, "Amending Executive Order 11246 Relating to Equal Employment Opportunity," 42 U.S.C. § 2000e note), and with any applicable Federal statutes, executive orders, regulations, and Federal policies that may in the future affect construction activities undertaken in the course of the Project. The Contractor agrees to take affirmative action to ensure that applicants are employed, and that employees are treated during employment, without regard to their race, color, creed, national origin, sex, sexual orientation, gender identity or age. Such action shall include, but not be limited to, the following: employment, upgrading, demotion or transfer, recruitment or recruitment advertising, layoff or termination; rates of pay or other forms of compensation; and selection for training, including apprenticeship. In addition, the Contractor agrees to comply with any implementing requirements FTA may issue.

(2) Age

In accordance with section 4 of the Age Discrimination in Employment Act of 1967, as amended, 29 U.S.C. § § 623, Federal transit law at 49 U.S.C. § 5332, and N.J.S.A. 10:3-1, the Contractor agrees to refrain from discrimination against present and prospective employees for reason of age. In addition, the Contractor agrees to comply with any implementing requirements FTA may issue.

(3) Disabilities

In accordance with section 102 of the Americans with Disabilities Act, as amended, 42 U.S.C. § 12112, the Contractor agrees that it will comply with the requirements of U.S.

Equal Employment Opportunity Commission, "Regulations to Implement the Equal Employment Provisions of the Americans with Disabilities Act," 29 C.F.R. Part 1630, pertaining to employment of persons with disabilities. In addition, the Contractor agrees to comply with N.J.S.A. 10:5-29.1 and any implementing requirements FTA may issue.

(d) The Contractor also agrees to include these requirements in each subcontract financed in whole or in part with Federal assistance provided by FTA, modified only if necessary to identify the affected parties.

(e) Information and Reports

The Contractor shall provide all information and reports required by the Regulations or directives issued pursuant thereto, and shall permit access to its books, records, accounts, other sources of information, and its facilities as may be determined by the Recipient or NJ TRANSIT or the FTA to be pertinent to ascertain compliance with such Regulations, orders and instruction. Where any information is required or a Contractor is in the exclusive possession of another who fails or refuses to furnish this information, the Contractor shall so certify to NJ TRANSIT, or the FTA, as appropriate, and shall set forth what efforts it has made to obtain the information.

(f) Sanctions for Noncompliance

In the event of the Contractor's noncompliance with the nondiscrimination provisions of this Contract, NJ TRANSIT shall impose such contract sanctions as it or the FTA may determine to be appropriate, including but not limited to:

- (1) Withholding of payments to the Contractor under the Contract until the Contractor complies; and/or
- (2) Cancellation, termination or suspension of the Contract, in whole or in part.

14.9 PATENT RIGHTS

If any invention, improvement, or discovery of the Contractor is conceived or first actually reduced to practice in the course of or under this Contract, which invention, improvement or discovery may be patentable under the laws of the United States of America or any foreign country, the Contractor shall immediately notify NJ TRANSIT and provide a detailed report for transmission to FTA.

The rights and responsibilities of NJ TRANSIT, the Contractor and FTA with respect to such invention, improvement, or discovery will be determined in accordance with applicable Federal laws, regulations, policies and any waiver thereof.

14.10 RCRA REQUIREMENTS: BUILDING INSULATION PRODUCTS AND FLY ASH IN CONCRETE

The Contractor agrees to comply with all the requirements of Section 6002 of the Resource Conservation and Recovery Act (RCRA), as amended (42 U.S.C. 6962), including but not limited to the regulatory

provisions of 40 C.F.R. Part 247, and Executive Order 12873, as they apply to the procurement of the items designated in Subpart B of 40 C.F.R. Part 247.

14.10.1 Building Insulation Products

NJ TRANSIT has adopted minimum recovered material content standards for the following types of insulating material:

<b>Material Type</b>	<b>Percent By Weight</b>
Cellulose Loose Fill and Spray-On	75 percent post-consumer recovered paper
Perlite Composite Board	23 percent post-consumer recovered paper
<u>Plastic Rigid Foam,</u> <u>Polyisocyanurate/Polyurethane</u>	
Rigid Foam:	9 percent recovered material
Foam-in-place:	5 percent recovered material
Glass Fiber Reinforced:	6 percent recovered material
Phenolic Rigid Foam	5 percent recovered material
Rock Wool	50 percent recovered material

Note: The minimum content standards are based on the weight of material (not volume) in the insulating core.

The Contractor agrees to certify, prior to delivery, that building insulation products listed above which are to be supplied under the Contract shall meet or exceed the applicable minimum content standard.

Where NJ TRANSIT has specified building insulation products for which no minimum content standard has been established, the Contractor agrees to certify, prior to delivery, the minimum percentage of recovered materials that such products shall contain.

Also, the Contractor agrees to provide, at the time of installation, an estimate of the actual total percentage of recovered material contained in the building insulation product and an estimate of the product's cost.

The Contractor shall also obtain from the original manufacturer documentation that verifies the recovered material content of the building insulation products supplied. Such documentation should include manufacturer records identifying batch numbers and total percentage and type of recovered materials contained in the product. If specific batch data is unavailable, the average of recovered materials used by the manufacturer in a specific insulation product over a one-month period may be used.

The requirement to supply building insulation products containing recovered materials to the maximum extent practicable is subject to the following limitations:

- (1) Unsatisfactory level of competition;
- (2) Unavailability within a reasonable period of time;
- (3) Inability to meet the performance standards in the applicable specifications;
- (4) Unavailability at a reasonable price.

Should the Contractor claim that one or more of the four limitations identified above applies to any building insulation products to be delivered or installed under this Contract, the Contractor shall so notify the Construction Manager in writing.

NJ TRANSIT reserves the right to reject any claims where the Contractor has failed to provide adequate evidence that one or more of the four limitations applies.

Failure to deliver or install building insulation products in accordance with these requirements shall be considered a material breach of the Contract.

#### 14.10.2 Fly Ash In Concrete

Portland cement, Type II, which has been pre-blended with a maximum of 15 percent fly ash, by weight, and conforming to ASTM C 595 may be used. When blended portland cement is used, no additional fly ash shall be added.

Fly ash for portland cement concrete shall conform to ASTM C 618, Class C or Class F except that the loss on ignition shall be not more than 3 percent. When Class C fly ash is used, the magnesium oxide shall not exceed 2.5 percent. Before each source of fly ash is approved, certified results of test conducted by a testing agency shall be submitted to and verified by the Department. Accompanying the certification shall be a statement from the supplier listing the source and type of coal, the methods used to burn, collect, and store the fly ash, and the quality control measures employed.

Conformance to the requirements for loss on ignition and fineness shall be determined by the supplier for each truck load of fly ash delivered to the mixing site. The test values determined shall be included on the delivery ticket. The Engineer may require that the fly ash not be used until the Department has performed tests for loss on ignition and fineness.

Fly ash for other uses shall conform to ASTM C 593 except that the loss on ignition shall be not more than 10 percent and the combined content of silica and aluminum oxide shall be a minimum of 50 percent.

14.11 FEDERAL EEO PROVISIONS FOR CONSTRUCTION CONTRACTS

The Contractor, in addition to complying with Article 11.2, shall comply with the following Federal EEO Provisions for Construction Contracts:

14.11.1 EQUAL EMPLOYMENT OPPORTUNITY

During the performance of this contract, the Contractor agrees as follows:

- a.) In connection with the execution of this Contract, the Contractor shall not discriminate against any employee or applicant for employment because of race, color, religion, sex, sexual orientation, gender identity, or national origin pursuant to Executive Order 11246, as amended. The Contractor shall take affirmative action to ensure that applicants are employed, and that employees are treated during their employment without regard to their race, color, religion, sex, sexual orientation, gender identity or national origin. Such action shall include, but not be limited to the following: employment, upgrading, demotion or transfer; recruitment or recruitment advertising; layoff or termination; rates of pay or other forms of compensation; and selection for training, including apprenticeship. The Contractor agrees to post in conspicuous places, available to employees and applicants for employment, notices to be provided setting forth the provisions of this nondiscrimination clause.
- b.) The Contractor will, in all solicitations or advertisements for employees placed by or on behalf of the Contractor, state that all qualified applicants will receive consideration for employment without regard to race, color, religion, sex, sexual orientation, gender identity, or national origin.
- c.) The Contractor will not discharge or in any other manner discriminate against any employee or applicant for employment because such employee or applicant has inquired about, discussed, or disclosed the compensation of the employee or applicant or another employee or applicant. This provision shall not apply to instances in which an employee who has access to the compensation information of other employees or applicants as a part of such employee's essential job functions discloses the compensation of such other employees or applicants to individuals who do not otherwise have access to such information, unless such disclosure is in response to a formal complaint or charge, in furtherance of an investigation, proceeding, hearing, or action, including an investigation conducted by the employer, or is consistent with the Contractor's legal duty to furnish information.
- d.) The Contractor will send to each labor union or representative of workers with which he has a collective bargaining agreement or other contract or understanding, a notice to be provided advising the said labor union or workers' representative of the Contractor's commitments under this Article, and shall post copies of the notice in conspicuous places available to employees and applicants for employment.

- e.) The Contractor will comply with all provisions of Executive Order 11246 of September 24, 1965, as amended by Executive Orders 11478, 11375, 12086, 13665, 13672 and of the rules, regulations and relevant orders of the Secretary of Labor.
- f.) The Contractor will furnish all information and reports required by Executive Order 11246, as amended, and by the rules, regulations, and orders of the Secretary of Labor or pursuant thereto, and will permit access to his books, records and accounts by the Federal Transit Administration (FTA) and the Secretary of Labor for purposes of investigation to ascertain compliance with such rules, regulations and orders.
- g.) In the event of the Contractor's noncompliance with the nondiscrimination clauses of this contract or with any of the said rules, regulations or orders, this contract may be cancelled, terminated or suspended in whole or in part and the Contractor may be declared ineligible for further Government contracts or federally assisted construction contracts in accordance with procedures authorized in Executive Order 11246, as amended, and such other sanctions as may be imposed and remedies invoked as provided in the said Executive Order or its amendments, or by rule, regulation or order of the Secretary of Labor, or as otherwise provided by law.
- h.) The Contractor will include the provisions of paragraphs (a) through (g) in every subcontract or purchase order unless exempted by rules, regulations or orders of the Secretary of Labor issued pursuant to Section 204 of Executive Order 11246, as amended,, so that such provisions will be binding upon each Subcontractor or vendor. The Contractor will take such action with respect to any subcontract or purchase order as FTA may direct as a means of enforcing such provisions, including sanctions for noncompliance; provided, however, that in the event a Contractor becomes involved in, or is threatened with, litigation with a Subcontractor or vendor as a result of such direction by FTA, the Contractor may request the United States to enter into such litigation to protect the interests of the United States.

14.11.2 NOTICE OF REQUIREMENT FOR AFFIRMATIVE ACTION TO ENSURE EQUAL EMPLOYMENT OPPORTUNITY (EXECUTIVE ORDER 11246)

- a.) The Contractor's attention is called to the "Equal Opportunity Clause" and the "Standard Federal Equal Employment Opportunity Construction Contract Specifications" set forth herein.
- b.) The goals and timetables for minority and female participation expressed in percentage terms for the Contractor's aggregate work force in each trade on all construction work in the covered area, are as follows:

**GOALS FOR MINORITY PARTICIPATION (Timetable Until Further Notice)**

<u>County</u>	<u>Goal Percent</u>
Atlantic	18.2
Bergen	22.6
Burlington	17.3
Camden	17.3
Cape May	14.5
Cumberland	16.0
Essex	17.3
Gloucester	17.3
Hudson	12.8
Hunterdon	17.0
Mercer	16.4
Middlesex	5.8
Monmouth	9.5
Morris	17.3
Ocean	17.0
Passaic	12.9
Salem	12.3
Somerset	17.3
Sussex	17.0
Union	17.3
Warren	1.6

**GOALS FOR FEMALE PARTICIPATION (Timetable Until Further Notice)**

<u>County</u>	<u>Goal Percent</u>
All	6.9

These goals are applicable to all the Contractor's construction work (whether or not it is Federal or federally assisted) performed in the covered area.

The Contractor's compliance with Executive Order 11246, as amended, and the regulations in 41 C.F.R. Part 60-4.1, et seq., shall be based on its implementation of the Equal Employment Opportunity Clause, specific affirmative action obligations required by the specifications set forth in 41 C.F.R. Part 60-4.3(a), and its efforts to meet the goals established for the geographical area where the contract resulting from this solicitation is to be performed. The hours of minority and female employment and training must be substantially uniform throughout the length of the contract and in each trade, and the Contractor shall make a good faith effort to employ minorities and women on each of its projects. The transfer of minority or female employees or



trainees from Contractor to Contractor or from project to project for the sole purpose of meeting the Contractor's goals shall be a violation of the contract, the Executive Order and the regulations in 41 C.F.R. Part 60-4, et seq. Compliance with the goals will be measured against the total work hours performed.

- c.) The Contractor shall provide written notification to the Director of the Office of Federal Contract Compliance Programs within ten (10) working days of award of any construction subcontract in excess of \$10,000 at any tier for construction work under the contract resulting from this solicitation. The notification shall list the name, address and telephone number of the Subcontractor; employer identification number; estimated dollar amount of the subcontract; estimated starting and completion dates of the subcontract; and the geographical area in which the contract is to be performed.
- d.) As used in this notice, and in the contract resulting from this solicitation, the "covered area" is the State of New Jersey.

14.11.3 STANDARD FEDERAL EQUAL EMPLOYMENT OPPORTUNITY CONTRACT SPECIFICATIONS (EXECUTIVE ORDER 11246, as amended)

- 1. As used in these specifications and defined by 41 C.F.R. Part 60-4.3:
  - (a) "Covered area" means the geographical area described in the solicitation from which this contract resulted;
  - (b) "Director" means Director, Office of Federal Contract Compliance Programs, United States Department of Labor, or any person to whom the Director delegates authority;
  - (c) "Employer identification number" means the Federal Social Security number used on the Employer's Quarterly Federal Tax Return, U.S. Treasury Department Form 941.
  - (d) "Minority" includes:
    - (i) Black (all persons having origins in any of the Black African racial groups not of Hispanic origin);
    - (ii) Hispanic (all persons of Mexican, Puerto Rican, Cuban, Central or South American or other Spanish culture or origin, regardless of race);
    - (iii) Asian and Pacific Islander (all persons having origins in any of the original peoples of the Far East, Southeast Asia, the Indian Subcontinent, or the Pacific Islands); and
    - (iv) American Indian or Alaskan Native (all persons having origins in any of the original peoples of North America and maintaining identifiable tribal affiliations through membership and participation or community identification).

2. Whenever the Contractor, or any Subcontractor at any tier, subcontracts a portion of the work involving any construction trade, it shall physically include in each subcontract in excess of \$10,000 the provisions of these specifications and the Notice which contains the applicable goals for minority and female participation and which is set forth in the solicitations from which this contract resulted.
3. If the Contractor is participating (pursuant to 41 C.F.R. Part 60-4.5) in a Hometown Plan approved by the U.S. Department of Labor in the covered area either individually or through an association, its affirmative action obligations on all work in the Plan area (including goals and timetables) shall be in accordance with that Plan for those trades which have unions participating in the Plan. Contractors must be able to demonstrate their participation in and compliance with the provisions of any such Hometown Plan. Each Contractor or Subcontractor participating in an approved Plan is individually required to comply with its obligations under the EEO clause, and to make a good faith effort to achieve each goal under the Plan in each trade in which it has employees. The overall good faith performance by other contractors or subcontractors toward a goal in an approved Plan does not excuse any covered Contractor's or Subcontractor's failure to make good faith efforts to achieve the Plan goals and timetables.
4. The Contractor shall implement the specific affirmative action standards provided in paragraphs 7(a) through (o) of this Article. The goals set forth in the solicitation from which this contract resulted are expressed as percentages of the total hours of employment and training of minority and female utilization the Contractor should reasonably be able to achieve in each construction trade in which it has employees in the covered area. The Contractor is expected to make substantially uniform progress toward its goals in each craft during the period specified.
5. Neither the provisions of any collective bargaining agreement, nor the failure by a union with whom the Contractor has a collective bargaining agreement, to refer either minorities or women shall excuse the Contractor's obligations under these specifications, Executive Order 11246, as amended, or the regulations promulgated pursuant thereto.
6. In order for the nonworking training hours of apprentices and trainees to be counted in meeting the goals, such apprentices and trainees must be employed by the Contractor during the training period, and the Contractor must have made a commitment to employ the apprentices and trainees at the completion of their training, subject to the availability of employment opportunities. Trainees must be trained pursuant to training programs approved by the U.S. Department of Labor.

7. The Contractor shall take specific affirmative actions to ensure equal employment opportunity. The evaluation of the Contractor's compliance with these specifications shall be based upon its effort to achieve maximum results from its actions. The Contractor shall document these efforts fully, and shall implement affirmative action steps at least as extensive as the following:
- (a) Ensure and maintain a working environment free of harassment, intimidation, and coercion at all sites, and in all facilities at which the Contractor's employees are assigned to work. The Contractor, where possible, will assign two or more women to each construction project. The Contractor shall specifically ensure that all foremen, superintendents, and other on-site supervisory personnel are aware of and carry out the Contractor's obligation to maintain such a working environment, with specific attention to minority or female individuals working at such sites or in such facilities.
  - (b) Establish and maintain a current list of minority and female recruitment sources, provide written notification to minority and female recruitment sources and to community organizations when the Contractor or its unions have employment opportunities available, and maintain a record of the organizations' responses.
  - (c) Maintain a current file of the names, addresses and telephone numbers of each minority and female off-the-street applicant and minority or female referral from a union, a recruitment source or community organization and of what action was taken with respect to each such individual. If such individual was sent to the union hiring hall for referral and was not referred back to the Contractor by the union, or, if referred, not employed by the Contractor, this shall be documented in the file with the reason therefor, along with whatever additional actions the Contractor may have taken.
  - (d) Provide immediate written notification to the Director and the Contract Compliance Officer of NJ TRANSIT when the union or unions with which the Contractor has a collective bargaining agreement has not referred to the Contractor a minority person or a woman sent by the Contractor, or when the Contractor has other information that the union referral process has impeded the Contractor's efforts to meet its obligations.
  - (e) Develop on-the-job training opportunities and/or participate in training programs for the area which expressly include minorities and women, including upgrading programs and apprenticeship and trainee programs relevant to the Contractor's employment needs, especially those programs funded or approved by the Department of Labor. The Contractor shall provide notice of these programs to the sources compiled under 7(b) above.

- (f) Disseminate the Contractor's EEO policy by providing notice of the policy to unions and training programs and requesting their cooperation in assisting the Contractor in meeting his EEO obligations; by including it in any policy manual and collective bargaining agreement; by publicizing it in the company newspaper, annual report, etc.; by specific review of the policy with all management personnel and with all minority and female employees at least once a year; and by posting the company EEO policy on bulletin boards accessible to all employees at each location where construction work is performed.
- (g) Review, at least annually, the company's EEO policy and affirmative action obligations under these specifications with all employees having any responsibility for hiring, assignment, layoff, termination or other employment decisions including specific review of these items with on-site supervisory personnel such as Superintendents, General Foremen, etc., prior to the initiation of construction work at any job site. A written record shall be made and maintained identifying the time and place of these meetings, persons attending, subject matter discussed, and disposition of the subject matter.
- (h) Disseminate the Contractor's EEO policy externally by including it in any advertising in the news media, specifically including minority and female news media, and providing written notification to and discussing the Contractor's EEO policy with other contractors and Subcontractors with whom the Contractor does or anticipates doing business.
- (i) Direct its recruitment efforts, both oral and written, to minority, female and community organizations, to schools with minority and female students and to minority and female recruitment and training organizations serving the Contractor's recruitment area and employment needs. Not later than one month prior to the date for the acceptance of applications for apprenticeship or other training by any recruitment source, the Contractor shall send written notification to organizations such as the above, describing the openings, screening procedures, and tests to be used in the selection process.
- (j) Encourage present minority and female employees to recruit other minority persons and women and, where reasonable, provide after school, summer and vacation employment to minority and female youth both on the site and in other areas of a Contractor's work force.
- (k) Validate all tests and other selection requirements where there is an obligation to do so under 41 C.F.R. Part 60-3.1 et seq.

- (l) Conduct, at least annually, an inventory and evaluation at least of all minority and female personnel for promotional opportunities and encourage these employees to seek or to prepare for, through appropriate training, etc., such opportunities.
  - (m) Ensure that seniority practices, job classifications, work assignments and other personnel practices, do not have a discriminatory effect by continually monitoring all personnel and employment related activities to ensure that the EEO policy and the Contractor's obligations under these specifications are being carried out.
  - (n) Document and maintain a record of all solicitations of offers for subcontracts from minority and female construction contractors and suppliers, including circulation of solicitations to minority and female contractors' associations and other business associations.
  - (o) Conduct a review, at least annually, of all supervisors' adherence to and performance under the Contractor's EEO policies and affirmative action obligations.
8. Contractors are encouraged to participate in voluntary associations which assist in fulfilling one or more of their affirmative action obligations (7 (a) through (o)). The efforts of a contractor association, joint contractor-union, contractor-community, or other similar group of which the Contractor is a member and participant, may be asserted as fulfilling any one or more of its obligations under 7(a) through (o) of this Article, provided that the Contractor actively participates in the group, makes every effort to assure that the group has a positive impact on the employment of minorities and women in the industry, ensures that the concrete benefits of the program are reflected in the Contractor's minority and female work force participation, makes a good faith effort to meet its individual goals and timetables, and can provide access to documentation which demonstrates the effectiveness of actions taken on behalf of the Contractor. The obligation to comply, however, is the Contractor's and failure of such a group to fulfill an obligation shall not be a defense for the Contractor's noncompliance.
9. A single goal for minorities and a separate goal for women have been established. The Contractor, however is required to provide equal employment opportunity and to take affirmative action for all minority groups, both male and female, and all women, both minority and non-minority. Consequently, the Contractor may be in violation of Executive Order 11246, as amended, if a particular group is employed in a substantially disparate manner (for example, even though the Contractor has achieved its goals for women generally, the Contractor may be in violation of the Executive Order if a specific minority group of women is underutilized).

10. The Contractor shall not use the goals and timetables or affirmative action standards to discriminate against any person because of race, color, religion, sex, sexual orientation, gender identity, or national origin.
11. The Contractor shall not enter into any subcontract with any person or firm debarred from Government contracts pursuant to Executive Order 11246, as amended.
12. The Contractor shall carry out such sanctions and penalties for violation of these specifications and of the Equal Employment Opportunity Clause, including suspension, termination and cancellation of existing subcontracts as may be imposed or ordered pursuant to Executive Order 11246, as amended, and its implementing regulations, by the Office of Federal Contract Compliance Programs. Any Contractor who fails to carry out such sanctions and penalties shall be in violation of these specifications and Executive Order 11246, as amended.
13. The Contractor, in fulfilling its obligations under this Article, shall implement specific affirmative action steps, at least as extensive as those standards prescribed in Paragraph 7 of these General Provisions, so as to achieve maximum results from its efforts to ensure equal employment opportunity. If the Contractor fails to comply with the requirements of Executive Order 11246, as amended, the implementing regulations, or this Article, the Director, Office of Federal Contract Compliance Programs, United States Department of Labor, or any person to whom the Director delegates authority, shall proceed in accordance with 41 C.F.R. Part 60-4.8. In connection with the foregoing, NJ TRANSIT or its Contract Compliance Officer may utilize any remedies that may be available.
14. The Contractor shall designate a responsible official to monitor all employment related activity to ensure that the company EEO policy is being carried out, to submit reports relating to the provisions herein as may be required by the Government and to keep records. Records shall at least include for each employee the name, address, telephone numbers, construction trade, union affiliation if any, employee identification number when assigned, social security number, race, sex, status (e.g., mechanic, apprentice, trainee, helper, or laborer), dates of changes in status, hours worked per week in the indicated trade, rate of pay, and locations at which the work was performed. Records shall be maintained in an easily understandable and retrievable form; however, to the degree that existing records satisfy this requirement, Contractors shall not be required to maintain separate records.
15. Nothing herein provided shall be construed as a limitation upon the application of other laws which establish different standards of compliance or upon the application of requirements for the hiring of local or other area residents (e.g., those under the Public Works Employment Act of 1977 and the Community Development Block Grant Program).

14.12 LIMITATIONS ON LOBBYING

The Contractor and its Subcontractors shall comply with 31 U.S.C. 1352, entitled "Limitation on Use of Appropriated Funds to Influence Certain Federal Contracting and Financial Transactions".

- 1.) No appropriated funds may be expended by the recipient of a Federal contract, grant, loan or cooperative agreement to pay any person for influencing or attempting to influence an officer or employee of any agency, a Member of Congress, an officer or employee of Congress or an employee of a Member of Congress in connection with any of the following covered Federal actions: the awarding of any Federal contract, the making of any Federal grant, the making of any Federal loan, the entering into of any cooperative agreement, and the extension, continuation, renewal, amendment or modification of any Federal contract, grant, loan or cooperative agreement.
- 2.) Any Contractor and any Subcontractor at any tier who requests or receives a Federally-assisted contract or subcontract in excess of \$100,000 from NJ TRANSIT shall file with NJ TRANSIT the certification attached to this Contract and entitled "Certification for Contracts, Grants, Loans and Cooperative Agreements", that the Contractor or Subcontractor, as applicable, has not made, and will not make, any payment prohibited by Paragraph 1 of this Section.
- 3.) Any Contractor and any Subcontractor who has made or has agreed to make any payment using non-appropriated funds (to include profits from any covered Federal action) which would be prohibited under Paragraph 1 of this Section if paid for with appropriated funds, shall file with NJ TRANSIT a disclosure form, which may be obtained from the Contracting Officer, entitled "Disclosure of Lobbying Activities".
- 4.) Any certification or disclosure form filed under Paragraphs 2 and 3 of this Section shall be forwarded from tier to tier until received by NJ TRANSIT. Any certification or disclosure form shall be treated as a material representation of fact upon which all receiving tiers shall rely. All liability arising from an erroneous representation shall be borne solely by the tier filing that representation and shall not be shared by any tier to which the erroneous representation is forwarded.
- 5.) The prohibition on the use of appropriated funds does not apply in the case of a payment of reasonable compensation to an officer or employee of the Contractor or Subcontractor if the payment is for agency and legislative liaison activities not directly related to a covered Federal action.
- 6.) The prohibition on the use of appropriated funds does not apply in the case of any reasonable payment to an officer or employee of a Contractor or Subcontractor or to a person, other than an officer or employee of a Contractor or Subcontractor, if the payment is for professional or technical

services rendered directly in the preparation, submission or negotiation of any Bid, proposal or application for a Federal contract, grant, loan or cooperative agreement.

14.13 SEISMIC SAFETY

The Contractor agrees that any new building or addition to an existing building will be designed and constructed in accordance with the standards for Seismic Safety required in USDOT Seismic Safety Regulations, 49 C.F.R. Part 41, and will certify to compliance to the extent required by the regulation. The Contractor also agrees to ensure that all work performed under this Contract including work performed by a Subcontractor is in compliance with the standards required by the Seismic Safety Regulations and the certification of compliance issues on the project.

14.14 EXCLUSIONARY OR DISCRIMINATORY SPECIFICATIONS

Except where otherwise required by Federal statute or regulations, the Contractor agrees that it will comply with the requirements of 49 U.S.C. § 5323(h)(3) by refraining from using exclusionary or discriminatory specifications in the performance of the Work.

14.15 NO FEDERAL GOVERNMENT OBLIGATIONS TO THIRD PARTIES

The Contractor agrees that, absent the Federal Government's express written consent, the Federal Government shall not be subject to any obligations or liabilities to the Contractor in connection with the performance of the Project. Notwithstanding any concurrence provided by the Federal Government in the approval of the Contract, the Federal Government continues to have no obligations or liabilities to the Contractor.

14.16 FALSE OR FRAUDULENT STATEMENTS AND CLAIMS

14.16.1 The Contractor recognizes that the requirements of the Program Fraud Civil Remedies Act of 1986, as amended, 49 U.S.C. §§ 3801 et seq. and USDOT regulations, "Program Fraud Civil Remedies," 49 C.F.R. Part 31, apply to its actions pertaining to the Project. Accordingly, by signing the Contract, the Contractor certifies or affirms the truthfulness and accuracy of any statement it has made, it makes, or it may make pertaining to the Contract. In addition to other penalties that may be applicable, the Contractor also acknowledges that if it makes a false, fictitious, or fraudulent claim, statement, submission, or certification, the Federal Government reserves the right to impose the penalties of the Program Fraud Civil Remedies Act of 1986, as amended, on the Contractor to the extent the Federal Government deems appropriate.

14.16.2 The Contractor also acknowledges that if it makes a false, fictitious, or fraudulent claim, statement, submission, or certification to the Federal Government in connection with an urbanized area formula project financed with Federal assistance authorized by 49 U.S.C. § 5307, the Government reserves the right to impose on the Contractor the penalties of 18 U.S.C. § 1001 and 49 U.S.C. § 5307(n)(1), to the extent the Federal Government deems appropriate.



14.17 VETERAN'S EMPLOYMENT

The Contractor and Subcontractors under this Federally-funded Contract shall ensure that they give a hiring preference, to the extent practicable, to veterans (as defined in 5 U.S.C. § 2108) who have the requisite skills and abilities to perform the construction work required under the Contract. This Sub-article shall not be understood, construed or enforced in any manner that would require an employer to give preference to any veteran over any equally qualified applicant who is a member of any racial or ethnic minority, female, an individual with a disability, or a former employee.

14.18 FEDERAL AID, LAWS AND REGULATIONS

This Contract is funded in whole or in part by the United States Government and is subject to all Federal laws and regulations governing Federally-financed projects.

(a) Changes to Federal Requirements

The Contractor shall at all times comply with all applicable FTA regulations, policies, procedures and directives, including without limitation those listed directly or by reference in the Master Agreement between NJ TRANSIT and the FTA, as they may be amended or promulgated from time to time during the term of this Agreement. Contractor's failure to so comply shall constitute a material breach of this Agreement unless the FTA determines otherwise.

(b) Incorporation of FTA Terms

These General Provisions include, in part, certain standard terms and conditions required by USDOT, whether or not expressly set forth in this Agreement. All Contractual provisions required by USDOT, as set forth in FTA circular 4220.1F, are hereby incorporated by reference. Anything to the contrary herein notwithstanding, all FTA mandated terms shall be deemed to control in the event of a conflict with other provisions contained in this Agreement. The Contractor shall not perform any act, fail to perform any act, or refuse to comply with any NJ TRANSIT requests which would cause NJ TRANSIT to be in violation of the FTA Master Agreement between NJ TRANSIT and the FTA.

# APPENDIX A

## SUBCONTRACTOR EVALUATION DATA FORM

---

(PROJECT)

---

(SUBCONTRACTOR)

---

(DATE)

# SUBCONTRACTOR EVALUATION DATA FORM

1. Proposed Project: \_\_\_\_\_
2. Proposed work or trade: \_\_\_\_\_ Division Nos.: \_\_\_\_\_
3. Approximate Contract Amount: \_\_\_\_\_
4. Company Name: \_\_\_\_\_  
\_\_\_\_\_ Corp. \_\_\_\_\_ Partnership \_\_\_\_\_ Individual \_\_\_\_\_ Joint Venture
5. Principal Office Location: \_\_\_\_\_  
\_\_\_\_\_  
Phone: \_\_\_\_\_ Person in Charge: \_\_\_\_\_
6. Name and Title of Principals:  
\_\_\_\_\_  
\_\_\_\_\_  
\_\_\_\_\_
7. Branch Office Locations:  
\_\_\_\_\_  
Phone: \_\_\_\_\_  
\_\_\_\_\_  
Phone: \_\_\_\_\_
8. Office which would be directly responsible for work at this project.  
\_\_\_\_\_  
\_\_\_\_\_  
\_\_\_\_\_
9. Subcontractor Information Data Form as required by Federal Regulation, submitted herewith.
10. Contractor has confirmed that the listed Subcontractor is not listed on the State of New Jersey, Department of Labor and Workforce Development, Division of Wage and Hour Compliance, Prevailing Wage Debarment List or on the Department of Treasury, Consolidated Debarment Report and Contractor has also confirmed that the listed Subcontractor is currently registered and active with no exclusion on the consolidated U.S. Government, System for Award Management (SAM) database.
11. Number of years organization has been under present name:  
\_\_\_\_\_
12. List all other names under which the company has done business and for how many years.  
\_\_\_\_\_  
\_\_\_\_\_  
\_\_\_\_\_
13. State Licensed or Certified to do business in:  
\_\_\_\_\_
14. Certificate of registration pursuant to P.L.1999, c.238, "THE PUBLIC WORKS CONTRACTOR REGISTRATION ACT": (Copy attached) Yes: \_\_\_\_\_ No: \_\_\_\_\_
15. Business Registration Certificate (P.L. 2004, c.57): (Copy attached) Yes: \_\_\_\_\_ No: \_\_\_\_\_

16. Have you ever failed to complete any work awarded to you? If so, note When, Where, And Why:

\_\_\_\_\_

17. List Name, address, type of work and person in charge for any sub-sub, 3<sup>rd</sup> tier subcontractors, or major suppliers to whom portions of this sub-contract will be left:

Name: \_\_\_\_\_ Phone: \_\_\_\_\_ Attn: \_\_\_\_\_  
Address: \_\_\_\_\_ Work: \_\_\_\_\_ Value: \_\_\_\_\_  
Name: \_\_\_\_\_ Phone: \_\_\_\_\_ Attn: \_\_\_\_\_  
Address: \_\_\_\_\_ Work: \_\_\_\_\_ Value: \_\_\_\_\_  
Name: \_\_\_\_\_ Phone: \_\_\_\_\_ Attn: \_\_\_\_\_  
Address: \_\_\_\_\_ Work: \_\_\_\_\_ Value: \_\_\_\_\_

18. Do you qualify as a DBE/SBE/ESBE on this project: \_\_\_\_\_

19. Surety company that normally handles bonding: \_\_\_\_\_

Company Name: \_\_\_\_\_ No. of Years: \_\_\_\_\_

Agent: \_\_\_\_\_ Phone: \_\_\_\_\_

Address: \_\_\_\_\_

Bond Limits: \_\_\_\_\_

20. Project references: (List four projects where you performed similar work to this project):

<u>NAME</u>	<u>ADDRESS</u>	<u>PHONE</u>	<u>CONTACT</u>
-------------	----------------	--------------	----------------

_____	_____	_____	_____
_____	_____	_____	_____

21. Are you listed in Dunn & Bradstreet: \_\_\_\_\_ What City? \_\_\_\_\_

22. List all projects that you are participating in litigation against the owner:

\_\_\_\_\_

23. Annual Billings: \_\_\_\_\_

24. The undersigned certifies that it is aware of the terms, conditions, specifications and other Contract requirements of the Prime Contract.

25. The undersigned certifies the truth and correctness of all statements and of all answers to questions made herein.

COMPANY: \_\_\_\_\_  
BY: \_\_\_\_\_  
TITLE: \_\_\_\_\_

# NJ TRANSIT

## SUBCONTRACTOR INFORMATION

### DATA FORM

#### **PURPOSE:**

Federal Regulations require that NJ TRANSIT obtain information on an ongoing basis from all companies seeking to do business with NJ TRANSIT as prime contractors or subcontractors. As part of the subcontractor evaluation process, prime contractors shall provide the required information for all subcontractors performing work under the contract.

Information may be completed on-line by visiting the following website:

<http://www.tcgionline.com/njtransitbidresponse.asp>

Prime contractors will need to create a company profile and password by clicking on the "Add or Update Bidder Profile" link.

Once the company profile and password are created, prime contractors may add Bid and subcontractor information by clicking on appropriate links.

Include the printed form with the Subcontractor Evaluation Data Form.\*

Completion and submission of this form will:

1. Place the firm in NJ TRANSIT'S database for use in developing Bidder's lists;
2. Assist NJ TRANSIT in establishing appropriate small and disadvantaged business enterprise goals; and,
3. Alert NJ TRANSIT of any changes in the goods and services provided.

#### **Important Notice about DBE/SBE/ESBE Certification:**

Submission of this form does not certify a firm as a Disadvantaged Business Enterprise with either NJ TRANSIT or the State of New Jersey. Contact NJ TRANSIT'S Office of Business of Diversity (973) 491-8060 for clarification of this form and for information regarding certification. For questions regarding the Bid package, contact the contract specialist.

# NEW JERSEY TRANSIT CORPORATION SUBCONTRACTOR INFORMATION DATA FORM

(MANDATORY FORM TO BE FILLED OUT ENTIRELY)

**NJT Contract No:** \_\_\_\_\_ **Project Name:** \_\_\_\_\_

**Prime Contractor Name:** \_\_\_\_\_

**Address:** \_\_\_\_\_

Complete the information below for **ALL SUBCONTRACTORS**

	SUBCONTRACTOR
<i>Company's Full Name</i>	
<i>Address</i>	
<i>City</i>	
<i>Zip</i>	
<i>County</i>	
<i>Phone</i>	
<i>Fax</i>	
<i>E-mail</i>	
<i>Owner</i>	
<i>Date Established</i>	
<i>Date Certified</i>	
<i>Ethnicity</i>	
<i>Gender</i>	
<i>Certification Status: Non SBE or SBE I, SBE II, SBE III, SBE IV or SBE V (please indicate all that apply)</i>	
<i>Federal Tax ID # / SSN #</i>	
<i>Annual Gross Receipts:</i> A – Less than \$500K B - \$500K to \$1M C - \$1M to \$2M D - \$2M to \$5M E - \$5M and over  <i>*indicate the letter that applies</i>	
<i>Primary Industry Operation Code:</i>	

## APPENDIX B- CLOSEOUT FORMS

Affidavit of Payment of Debts and Claims

Affidavit of Release of Liens

Consent of Surety to Final Payment

Certificate of amounts due workers for wages on the work pursuant  
to N.J.S.A. 34:11-56.25 et seq.

Certificate of Substantial Completion

Certificate of Partial Acceptance

Certificate of Final Acceptance

Proposed Final Certificate of Payment

Final Certificate of Payment

Subcontractor Affidavit of Payment of Debts and Claims

Subcontractor Affidavit of Release of Liens

Consent of Surety to Final Payment to the Subcontractor

Subcontractor's Certificate of amounts due workers for wages on the work pursuant  
to N.J.S.A. 34:11-56.25 et seq.

Certificate of Final Acceptance of Subcontractor's Work

AFFIDAVIT OF PAYMENT OF DEBTS AND CLAIMS

TO: New Jersey Transit Corporation  
One Penn Plaza East  
Newark, New Jersey 07105-2246

CONTRACT NO.:

CONTRACTOR:

PROJECT:

CONTRACT DATE:

STATE OF:

COUNTY OF:

The undersigned, pursuant to Sub-article 12.8.1 of the Contract's General Provisions for Construction, hereby certifies that, except as listed below he has paid in full or has otherwise satisfied all obligations for all materials and equipment furnished, for all work, labor, and services performed, and for all known indebtedness and claims against the CONTRACTOR for damages arising in any manner in connection with the performance of the Contract referenced above for which the NEW JERSEY TRANSIT CORPORATION or its property might in any way be held responsible.

EXCEPTIONS: (If none, write "NONE". The CONTRACTOR shall furnish bond satisfactory to the NEW JERSEY TRANSIT CORPORATION for each exception.)

SIGNED,  
CONTRACTOR

Subscribed and sworn to before me this  
\_\_\_\_\_ day of \_\_\_\_\_, 20\_\_\_\_\_

Notary Public of

My commission expires \_\_\_\_\_, 20\_\_\_\_\_

By: \_\_\_\_\_

Title: \_\_\_\_\_

(SEAL)



AFFIDAVIT OF RELEASE OF LIENS

TO: New Jersey Transit Corporation  
One Penn Plaza East  
Newark, New Jersey 07105-2246

CONTRACT NO.:

CONTRACTOR:

PROJECT:

CONTRACT DATE:

STATE OF:

COUNTY OF:

The undersigned, pursuant to Sub-article 12.8.1 of the Contract's General Provisions for Construction, hereby certifies that to the best of his knowledge, information and belief, except as listed below, there are no liens filed against any property of the NEW JERSEY TRANSIT CORPORATION by the CONTRACTOR, or any subcontractors, suppliers of materials and equipment, or performers of work, labor or services arising from the performance of the Contract referenced above.

**EXCEPTIONS:** (If none, write "NONE". The CONTRACTOR shall furnish bond satisfactory to the NEW JERSEY TRANSIT CORPORATION for each exception.)

SIGNED,  
CONTRACTOR

Subscribed and sworn to before me this  
\_\_\_\_\_ day of \_\_\_\_\_, 20\_\_\_\_\_

Notary Public of

My commission expires \_\_\_\_\_, 20\_\_\_\_\_

By: \_\_\_\_\_

Title: \_\_\_\_\_

(SEAL)

CONSENT OF SURETY TO FINAL PAYMENT

Bond No.

TO: New Jersey Transit Corporation
One Penn Plaza East
Newark, New Jersey 07105-2246

CONTRACT NO.:

CONTRACTOR:

PROJECT:

CONTRACT DATE:

In accordance with the General Provisions for Construction, Sub-article 12.8.1 of the Contract between the NEW JERSEY TRANSIT CORPORATION and the CONTRACTOR as indicated above, the

, SURETY COMPANY

on bond of

, CONTRACTOR

hereby approves to the final payment to the CONTRACTOR, and agrees that final payment to the CONTRACTOR shall not relieve the SURETY COMPANY of any of its obligations to

NEW JERSEY TRANSIT CORPORATION
One Penn Plaza East
Newark, New Jersey 07105-2246

, OWNER

as set forth in said Surety Company's bond.

IN WITNESS WHEREOF, the SURETY COMPANY has hereunto set its hand this \_\_\_ day of \_\_\_, 20\_\_.

Surety Company

Attest: \_\_\_\_\_

Signature of Authorized Representative

(Seal):

Title

CERTIFICATE OF AMOUNTS DUE WORKERS FOR WAGES

TO: New Jersey Transit Corporation
One Penn Plaza East
Newark, New Jersey 07105-2246

CONTRACT NO.:

CONTRACTOR:

PROJECT:

CONTRACT DATE:

The undersigned CONTRACTOR, pursuant to Sub-articles 11.1.6 and 12.8.1 of the Contract's General Provisions for Construction, hereby certifies that, except as listed below he has paid in full all wages earned on the work to all laborers, mechanics, apprentices, trainees, watchmen, guards, and workers in general employed by him or by any subcontractor performing work under the Contract on the Project. It is further certified that all laborers, mechanics, apprentices, trainees, watchmen, guards, and workers in general have been paid wages at rates not less than those required by the Contract provisions and pursuant to N.J.S.A. 34:11-56.25 et seq., and that the work performed by each such laborer, mechanic, apprentice, trainee, watchman, guard, and worker in general conformed to the classifications set forth in the Contract or training program provisions applicable to the wage rate paid.

EXCEPTIONS: (If none, write "NONE"; for each exception, the CONTRACTOR shall provide complete and detailed explanation.)

SIGNED,
CONTRACTOR

Subscribed and sworn to before me this
\_\_\_\_\_ day of \_\_\_\_\_, 20\_\_\_\_\_

Notary Public of
My commission expires \_\_\_\_\_, 20\_\_\_\_\_

(SEAL)

By: \_\_\_\_\_

Title: \_\_\_\_\_

Date: \_\_\_\_\_

CERTIFICATE OF SUBSTANTIAL COMPLETION

TO: New Jersey Transit Corporation  
One Penn Plaza East  
Newark, New Jersey 07105-2246

CONTRACT NO.:

CONTRACTOR:

PROJECT:

CONTRACT DATE:

The undersigned Project Manager hereby certifies that a field inspection performed on \_\_\_\_\_, 20\_\_ at the above captioned Project revealed that the CONTRACTOR has substantially completed his base contract and all authorized additional work for the following items of work:

All Contract Bid Items

Bid Item(s) No.

Other

It is further certified that the items of work above enumerated have been satisfactorily completed in accordance with the Contract Documents, and that as of the aforementioned date the NEW JERSEY TRANSIT CORPORATION may take beneficial occupancy of the subject work.

The Remaining Work to be completed in order to achieve one hundred percent (100%) completion is hereby listed in the Punch List Work attached hereto.

**SIGNED,**

**ACCEPTED,**

**NJ TRANSIT**

**CONTRACTOR**

By: \_\_\_\_\_

By: \_\_\_\_\_

Title: \_\_\_\_\_

Title: \_\_\_\_\_

Date: \_\_\_\_\_

Date: \_\_\_\_\_

CERTIFICATE OF PARTIAL ACCEPTANCE

TO: New Jersey Transit Corporation
One Penn Plaza East
Newark, New Jersey 07105-2246

CONTRACT NO.:

CONTRACTOR:

PROJECT:

CONTRACT DATE:

The undersigned Project Manager hereby certifies that a field inspection performed on \_\_\_\_\_, 20\_\_ at the above captioned Project revealed that the CONTRACTOR has completed one hundred percent (100%) of the work described below within its base contract and all authorized additional work for the following items of work:

Bid Item(s) No.

Other

It is further certified that the items of work above enumerated have been satisfactorily completed in accordance with the Contract Documents, and that as of the aforementioned date the NEW JERSEY TRANSIT CORPORATION may take beneficial occupancy of the subject work, subject to the terms of general provision Sub-Article 13.1.

SIGNED,

ACCEPTED,

NJ TRANSIT

CONTRACTOR

By: \_\_\_\_\_

By: \_\_\_\_\_

Title: \_\_\_\_\_

Title: \_\_\_\_\_

Date: \_\_\_\_\_

Date: \_\_\_\_\_

CERTIFICATE OF FINAL ACCEPTANCE

TO: New Jersey Transit Corporation  
One Penn Plaza East  
Newark, New Jersey 07105-2246

CONTRACT NO.:

CONTRACTOR:

PROJECT:

CONTRACT DATE:

In accordance with Sub-article 12.8.1.9 and 13.3.1 of the Contract's General Provisions for Construction, the undersigned CONTRACTOR hereby notifies that as of \_\_\_\_\_, 20\_\_ the base contract and all authorized additional work has been 100% completed, including but not limited to the Remaining Work (Punch List Work) listed on the attached Certificate(s) of Substantial Completion.

SIGNED,

CONTRACTOR

By: \_\_\_\_\_

Title: \_\_\_\_\_

The undersigned Project Manager hereby certifies that on \_\_\_\_\_, 20\_\_ a final field inspection was performed on the Project and all base and authorized additional work found to be 100% complete in accordance with the Contract Documents.

In testimony thereof, this Certificate of Final Acceptance is signed on this \_\_\_\_ day of \_\_\_\_\_, 20\_\_.

SIGNED,

CONCURRENCE,

\_\_\_\_\_  
Project Manager

\_\_\_\_\_  
Contracting Officer

\_\_\_\_\_  
Title

\_\_\_\_\_  
Title

PROPOSED FINAL CERTIFICATE OF PAYMENT

TO: New Jersey Transit Corporation
One Penn Plaza East
Newark, New Jersey 07105-2246

CONTRACT NO.:

CONTRACTOR:

PROJECT:

CONTRACT DATE:

The undersigned Project Manager, considering that

, CONTRACTOR

on the above referenced Contract has completed one hundred percent (100%) of the base contract and all authorized additional work, and fulfilled all his contractual obligations including those enumerated in Sub-article 12.8.1 of the Contract's General Provisions for Construction, hereby proposes that a Final Payment in the amount of \_\_\_\_\_ be issued to said CONTRACTOR in compensation for the unpaid balance of his work under this Contract.

Table with 2 columns: Description and Amount. Rows include Original Contract Value, Total Contract Changes Value, Changed Contract Value, Less: Payments to Date, Balance Due Contractor, Less: Deductions, and Total Final Payment Amount.

(1) Deductions Explanations:

It is further understood that this Final Payment includes all direct and indirect costs attributable to this Contract, and that the CONTRACTOR will not seek further compensation for any other costs related to this Contract.

SIGNED,

ACCEPTED CONTRACTOR,

Title: \_\_\_\_\_
Date: \_\_\_\_\_

Title: \_\_\_\_\_
Date: \_\_\_\_\_

FINAL CERTIFICATE OF PAYMENT  
(Attach to Final Payment Request)

TO: New Jersey Transit Corporation  
One Penn Plaza East  
Newark, New Jersey 07105-2246

CONTRACT NO.:

CONTRACTOR:

PROJECT:

CONTRACT DATE:

The undersigned Contracting Officer, considering that

, CONTRACTOR

on the above referenced Contract has completed one hundred percent (100%) of the base contract and all authorized additional work, and fulfilled all his contractual obligations including those enumerated in Sub-article 12.8.1 of the Contract's General Provisions for Construction, hereby proposes that a Final Payment in the amount of \_\_\_\_\_ be issued to said CONTRACTOR in compensation for the unpaid balance of his work under this Contract.

Original Contract Value:	\$	
Total Contract Changes Value		_____
Changed Contract Value:	\$	
Less: Payments to Date:		_____
Balance Due Contractor:	\$	
Less: Deductions:		_____ (1)
Total Final Payment Amount:	\$	_____

(1) Deductions Explanations:

It is further understood that this Final Payment includes all direct and indirect costs attributable to this Contract, and that the CONTRACTOR will not seek further compensation for any other costs related to this Contract.

SIGNED,

ACCEPTED CONTRACTOR,

\_\_\_\_\_

\_\_\_\_\_

Title: \_\_\_\_\_

Title: \_\_\_\_\_

Date: \_\_\_\_\_

Date: \_\_\_\_\_



**SUBCONTRACTOR AFFIDAVIT OF PAYMENT OF DEBTS AND CLAIMS**

**TO: New Jersey Transit Corporation  
One Penn Plaza East  
Newark, New Jersey 07105-2246**

**CONTRACT NO.:**

**CONTRACTOR:**

**PROJECT:**

**SUBCONTRACTOR:**

**CONTRACT DATE:**

**STATE OF:**

**COUNTY OF:**

*The undersigned, pursuant to Sub-article 12.6.7 of the Contract's General Provisions for Construction, hereby certifies that, except as listed below, he has paid in full or has otherwise satisfied all obligations for all materials and equipment furnished for all work, labor, and services performed, and for all known indebtedness and claims against the SUBCONTRACTOR for damages arising in any manner in connection with the performance of the Contract referenced above for which the NEW JERSEY TRANSIT CORPORATION or its property might in any way be held responsible.*

**EXCEPTIONS:** *(If none, write "NONE". The CONTRACTOR shall furnish bond satisfactory to the NEW JERSEY TRANSIT CORPORATION for each exception.)*

**SIGNED,  
SUBCONTRACTOR**

*Subscribed and sworn to before me this  
\_\_\_\_\_ day of \_\_\_\_\_, 20\_\_\_\_\_*

*Notary Public of*

*My commission expires \_\_\_\_\_, 20\_\_\_\_\_*

By: \_\_\_\_\_

Title: \_\_\_\_\_

(SEAL)

**SIGNED,  
CONTRACTOR**

*Subscribed and sworn to before me this  
\_\_\_\_\_ day of \_\_\_\_\_, 20\_\_\_\_\_*

*Notary Public of*

*My commission expires \_\_\_\_\_, 20\_\_\_\_\_*

By: \_\_\_\_\_

Title: \_\_\_\_\_

(SEAL)

SUBCONTRACTOR AFFIDAVIT OF  
RELEASE OF LIENS

**TO:** *New Jersey Transit Corporation  
One Penn Plaza East  
Newark, New Jersey 07105-2246*

**CONTRACT NO.:**

**CONTRACTOR:**

**PROJECT:**

**SUBCONTRACTOR:**

**CONTRACT DATE:**

**STATE OF:**

**COUNTY OF:**

*The undersigned, pursuant to Sub-article 12.6.7 of the Contract's General Provisions for Construction, hereby certifies that to the best of his knowledge, information and belief, except as listed below, there are no liens filed against any property or Contract funds of the NEW JERSEY TRANSIT CORPORATION by the SUBCONTRACTOR, or its suppliers of materials and equipment, or performers of work, labor or services arising from the performance of the Contract referenced above.*

**EXCEPTIONS:** *(If none, write "NONE". The CONTRACTOR shall furnish bond satisfactory to the NEW JERSEY TRANSIT CORPORATION for each exception.)*

**SIGNED,**

*Subscribed and sworn to before me this*

**SUBCONTRACTOR**

*\_\_\_\_\_ day of \_\_\_\_\_, 20\_\_\_\_\_*

*Notary Public of*

*My commission expires \_\_\_\_\_, 20\_\_\_\_\_*

*By: \_\_\_\_\_*

*(SEAL)*

*Title: \_\_\_\_\_*

**SIGNED,**

*Subscribed and sworn to before me this*

**CONTRACTOR**

*\_\_\_\_\_ day of \_\_\_\_\_, 20\_\_\_\_\_*

*Notary Public of*

*My commission expires \_\_\_\_\_, 20\_\_\_\_\_*

*By: \_\_\_\_\_*

*(SEAL)*

*Title: \_\_\_\_\_*

CONSENT OF SURETY  
PAYMENT TO THE SUBCONTRACTOR

Bond No.

---

TO: New Jersey Transit Corporation  
One Penn Plaza East  
Newark, New Jersey 07105-2246

CONTRACT NO.:

CONTRACTOR:

PROJECT:

SUBCONTRACTOR:

CONTRACT DATE:

---

In accordance with the General Provisions for Construction, Sub-article 12.6.7, of the Contract between the NEW JERSEY TRANSIT CORPORATION and the CONTRACTOR as indicated above, the

, SURETY COMPANY

on bond of

, CONTRACTOR

hereby consents to the final payment to the SUBCONTRACTOR, and agrees that final payment to the SUBCONTRACTOR shall not relieve the SURETY COMPANY of any of its obligations to

NEW JERSEY TRANSIT CORPORATION  
One Penn Plaza East  
Newark, New Jersey 07105-2246

, OWNER

as set forth in said Surety Company's bond.

IN WITNESS WHEREOF, the SURETY COMPANY has hereunto set its hand this \_\_\_\_ day of \_\_\_\_\_, 20\_\_.

Attest: \_\_\_\_\_

\_\_\_\_\_  
Surety Company

(Seal):

\_\_\_\_\_  
Signature of Authorized Representative

\_\_\_\_\_  
Title

**SUBCONTRACTOR'S CERTIFICATE OF AMOUNTS DUE WORKERS FOR WAGES**

**TO: New Jersey Transit Corporation  
One Penn Plaza East  
Newark, New Jersey 07105-2246**

**CONTRACT NO.:**

**CONTRACTOR:**

**PROJECT:**

**SUBCONTRACTOR:**

**CONTRACT DATE:**

The undersigned SUBCONTRACTOR, pursuant to Sub-articles 11.1.6 and 12.6.7 of the Contract's General Provisions for Construction, hereby certifies that, except as listed below, he has paid in full all wages earned on the work to all laborers, mechanics, apprentices, trainees, watchmen, guards, and workers in general employed by him. It is further certified that all laborers, mechanics, apprentices, trainees, watchmen, guards, and workers in general have been paid wages at rates not less than those required by the Contract provisions and pursuant to N.J.S.A. 34:11-56.25 et seq., and that the work performed by each such laborer, mechanic, apprentice, trainee, watchman, guard, and worker in general conformed to the classifications set forth in the Contract or training program provisions applicable to the wage rate paid.

**EXCEPTIONS:** (If none, write "NONE"; for each exception, the SUBCONTRACTOR shall provide complete and detailed explanation.)

**SIGNED,**

Subscribed and sworn to before me this

**SUBCONTRACTOR**

\_\_\_\_\_ day of \_\_\_\_\_, 20\_\_\_\_\_

Notary Public of

By: \_\_\_\_\_

My commission expires \_\_\_\_\_, 20\_\_\_\_\_

Title: \_\_\_\_\_

(SEAL)

Date: \_\_\_\_\_

**SIGNED,**

Subscribed and sworn to before me this

**CONTRACTOR**

\_\_\_\_\_ day of \_\_\_\_\_, 20\_\_\_\_\_

Notary Public of

By: \_\_\_\_\_

My commission expires \_\_\_\_\_, 20\_\_\_\_\_

Title: \_\_\_\_\_

(SEAL)

Date: \_\_\_\_\_

CERTIFICATE OF FINAL ACCEPTANCE OF SUBCONTRACTOR'S WORK

TO: New Jersey Transit Corporation
One Penn Plaza East
Newark, New Jersey 07105-2246

CONTRACT NO.:

CONTRACTOR:

PROJECT:

SUBCONTRACTOR:

CONTRACT DATE:

In accordance with Sub-article 12.6.7 of the Contract's General Provisions for Construction, the undersigned SUBCONTRACTOR hereby notifies the NJ TRANSIT Corporation that as of \_\_\_\_\_, 20\_\_ its Subcontract work and all authorized additional work has been 100% completed, including but not limited to the Remaining Work (Punch List Work) listed on the attached Certificate(s) of Substantial Completion.

SIGNED,
SUBCONTRACTOR

SIGNED,
CONTRACTOR

By: \_\_\_\_\_

By: \_\_\_\_\_

Title: \_\_\_\_\_

Title: \_\_\_\_\_

The undersigned Project Manager hereby certifies that on \_\_\_\_\_, 20\_\_ a final field inspection was performed on the Subcontractor's work and all Subcontract work and authorized additional work found to be 100% complete in accordance with the Contract Documents.

This Certificate of Final Acceptance of Subcontractor's work is signed on this \_\_\_\_ day of \_\_\_\_\_, 20\_\_.

SIGNED,
Project Manager

CONCURRENCE,
Contracting Officer

Title

Title

## **APPENDIX C CONTRACT EXECUTION FORM**

### **CONTRACT NO.**

This Agreement made this \_\_\_\_\_ day of \_\_\_\_\_, 20\_\_\_\_, between the New Jersey Transit Corporation, hereinafter referred to as NJ TRANSIT, and \_\_\_\_\_ hereinafter referred to as the Contractor.

### **WITNESSETH:**

Whereas, the said Contractor, for and in consideration of the payments hereinafter specified and agreed to be made by NJ TRANSIT, hereby covenants and agrees to furnish and deliver all materials and to do and perform all work and labor required to complete the \_\_\_\_\_ within \_\_\_\_\_ consecutive calendar days from the issuance of the official notice to proceed, in strict and entire conformity with the specifications for the project, which said specifications are as follows and are hereby made a part of this Contract as fully and with the same effect as if the same had been set forth at length in the body of this Contract:

*Bidders Proposal*  
*Performance / Payment Bond*  
*Non-Collusion Affidavit*  
*New Jersey Prevailing Wage Determination*  
*Federal Prevailing Wage Determination*  
*Prevailing Wage Affidavit*  
*Contractor's Certification of Eligibility*  
*Affidavit of Compliance*  
*Ownership Disclosure*  
*Disclosure of Investment Activities in Iran*  
*Federal EEO Provisions for Construction Contracts*  
*State EEO Provisions for Construction Contracts*  
*Certification for Contracts, Grants, Loans and*  
*Cooperative Agreements*  
*Buy America Certificate*  
*DBE Provisions*  
*General Provisions*  
*Special Provisions*  
*Technical Provisions*  
*Addendum: \_\_\_\_\_*

The Contractor agrees to make payment of all proper charges for labor and materials required in the aforementioned work.

*It is also agreed and understood that the acceptance by the Contractor of the final payment by NJ TRANSIT shall be considered as a release in full of all claims against the Executive Director and NJ TRANSIT out of, or by reason of, the work done and materials furnished under this Contract.*

*In consideration of the premises, NJ TRANSIT hereby agrees to pay to the Contractor for the said work when completed in accordance with the said specifications, the sum of \$\_\_\_\_\_. It is understood that payments shall be the total of the unit prices written in this Contract for the work actually done.*

*In Witness Whereof, the Contracting Officer of NJ TRANSIT has signed this instrument and caused it to be attested, and the Contractor has caused this instrument to be signed by its \_\_\_\_\_ and attested by its \_\_\_\_\_ the day and year first written.*

**ATTEST:**

**NEW JERSEY TRANSIT CORPORATION**

\_\_\_\_\_

By: \_\_\_\_\_  
Contracting Officer

**ATTEST:**

**CONTRACTOR**

\_\_\_\_\_  
Name:  
Title:

By: \_\_\_\_\_  
Name:  
Title:

*The above Contract has been reviewed and approved as to form only.*

**CHRISTOPHER S. PORRINO  
ATTORNEY GENERAL OF NEW JERSEY**

By: \_\_\_\_\_  
Deputy Attorney General

## APPENDIX D

### GOVERNING RULES FOR WORKING WITHIN THE RAILROAD RIGHT OF WAY

#### A. GENERAL REQUIREMENTS FOR WORKING WITHIN NJ TRANSIT'S RIGHT OF WAY

Contractors shall cooperate at all times with officials of NJ TRANSIT and use all reasonable care and diligence in their work to avoid accidents, damage or unnecessary delay to, or interference with, passenger trains and other property of NJ TRANSIT. Contractors are to be advised that a pre-construction meeting will be required prior to any work commencing on NJ TRANSIT property (within the Right-of-Way). In advance of any work on the property, a two-hour "NJTRO Contractor Safety Program" is to be administered by the New Jersey Transit Rail Operations ("NJTRO") Safety Department for the sponsor agency resident Engineer and Contractor's Safety Coordinator and Crane Groundmen. The Contractor's Construction Superintendent should contact the Safety Department at (973) 522-3719 to arrange for the scheduling of this program.

Contractors are to be advised that all construction operations within and over the limits of NJ TRANSIT's Right-of-Way shall be accomplished by methods which will in no way cause damage to the tracks, facilities, aerial or underground lines, embankments or drainage systems. It shall be the Contractor's responsibility to provide for protection of the tracks and embankments as shown on approved plans or as field approved in a safe and satisfactory manner, to install and maintain such shoring, sheeting and bracing as may be required, and to remove and dispose of such protective facilities upon completion of the work. Blasting will not be permitted on or along the right-of-way without prior written approval of NJ TRANSIT. All damage to NJ TRANSIT property caused by the Contractor's operations shall be repaired by the Contractor, or at his cost by NJ TRANSIT at the discretion of NJTRO. Work shall not continue until such damage is repaired and the railroad is back in service.

Whenever, in the judgment of NJTRO, work within or above the railroad's right-of-way may affect or involve the safe movement of its trains, the time and method of doing such work shall first be submitted in writing and approved by NJTRO. This approval shall not be considered as releasing the Contractor from responsibility or liability for any damage which NJTRO may suffer, or for which it may be held liable, by the action or omissions of the Contractor or those of his Sub-Contractors, or his or their employees.

Contractors shall provide written notice not less than ten (10) calendar days in advance of any work to be performed within or above the right-of-way, or other work which may affect railroad safety to: Director of Right-of-Way Engineering, NJ TRANSIT Rail Operations, One Penn Plaza East, Newark, NJ 07105.



NJTRO will require protective personnel to be on duty to protect its operations when the Contractor is working within the property right-of-way. Flag protection will be required when the Contractor is on, above or below, or immediately adjacent to NJTRO property or having the capability of obstructing an adjacent track. The specific responsibilities of the NJTRO Flagman are to provide enforcement of NJTRO Safety and Operating rules and other items as provided in these General Requirements as discussed in the "Contractor Safety Program", and is not provided for Engineering related matters.

Where such work is in proximity (20 feet or less) or has the potential to come in contact with overhead electrical wires or facilities, before any work proceeds, an on-site safety meeting must be conducted to determine the identity of such wires or facilities and appropriate steps to be taken. If owned by NJTRO, a qualified Class A employee(s) will be assigned who will take the necessary precautions in accordance with the NJTRO-3 Electrical Operating Instructions. All cranes and hoisting equipment used in this application must be properly grounded in accordance with NJTRO Specification MW-252.

When Crane Operators' visibility is impaired during any hoisting operation; Spotters or qualified Groundmen shall be utilized to guide the Operator. Universal hand signals shall be utilized and their meaning clearly understood between Operator and Spotter. When visual contact between the Operator and Spotter is impaired, two-way radio contact must be utilized.

If a temporary crossing of railroad tracks is necessary, Contractors shall apply to NJ TRANSIT in writing for such a crossing, and, if required, NJTRO shall execute its regular form of private grade crossing agreement covering the crossing desired and providing for the Contractor to pay all construction, maintenance, removal, protection, and other costs and affording contractual liability insurance in the amounts required.

The minimum hours per day for employees engaged in flagging or protection purposes will be eight (8) hours, plus appropriate travel time. For all time over eight (8) hours, the overtime rate will be charged. Personnel used in flagging service will be paid deadhead (traveling) time to and from headquarters each day, plus transportation from headquarters to the site of the work if required [in accordance with the current collective bargaining agreement]. It will be the responsibility of the Contractor to provide transportation for the Flagmen from and to the nearest NJTRO train station, as necessary.

NJTRO will assign Inspectors and /or Engineers during the time the Contractor is engaged in construction work on railroad property to provide general coordination of construction operations, to insure adherence to plans and specifications, and to insure the use of approved construction methods. It is to be understood that the providing of Inspectors, Engineers, Operators, Conductors, Flagmen or other forces, and the taking of any other precautions deemed necessary by NJTRO shall not relieve the Contractor

or his Sub-Contractor from liability for payment of damages caused by their respective operations.

All of NJTRO's costs shall be at the prevailing rates of pay in accordance with railroad accounts, and shall include overtime burden, [if overtime pay is warranted], and Workmen's Compensation Insurance, Public Liability Insurance, Property Damage Insurance, Railroad Unemployment Insurance, Railroad Retirement, Excise Tax, Vacation allowance, and other standard and legal costs, including overhead for supervision and accounting. In general, a recommendation is made that final payment to Contractors, not be made until NJTRO has been reimbursed in full for all of the costs.

Typically, use of NJ TRANSIT property will be restricted as follows, unless specifically authorized by the on-site NJTRO qualified employee (Flagman):

- (a) All workers must maintain a distance of no less than eighteen (18) feet from the track.
- (b) Any tools and equipment being utilized must not extend closer than eighteen (18) feet from the track.
- (c) When a train is approaching, all workers must cease work, stand clear of the track, and face the approaching train.
- (d) No worker is permitted to cross the railroad tracks at any area other than designated grade crossings.
- (e) No tools or working materials are permitted to be left along the NJTRO right-of-way.
- (f) In no event shall equipment or material be transported across a track or tracks without special permission and appropriate flagging protection.
- (g) All personnel, equipment and materials to be used during the construction shall be kept at all times at least fifteen (15) feet from all electrical, signal and communication systems unless protected by an Electrical, Signal or Communication's Department representative. The Contractor is responsible for damage to NJTRO property and any utilities located thereon, whether above or below ground.
- (h) All personnel, equipment and materials to be used during the construction in electrified territory shall also be kept at all times at least fifteen (15) feet from overhead trolley, messenger, static and transmission lines unless clearance and protection is provided by a qualified Electric Traction Department Class A High Tension Lineman.

- (i) All lifting operations shall be reviewed in meeting a standard requirement for a positive block to be installed on the hoisting equipment. This positive block is required to avoid contact with facilities or interfere with safe train operations.
- (j) When construction activity involves any type of hoisting procedure adjacent to aerial lines, the Contractor shall furnish NJTRO with sufficient florescent orange rubber goods, as determined by NJTRO, to be installed as an aid for equipment Operators and Groundmen in visually locating the aerial lines, and as additional protection against damage.

**ENGINEERING DATA REQUIRED FOR ERECTION, DEMOLITION  
OR OTHER HOISTING OPERATIONS PROPOSED**

1. A detailed plan must be submitted and approved by NJTRO, showing locations of cranes or hoisting devices (both horizontally and vertically), operating radii, positive stops and delivery or disposal locations. The location of all tracks and other railroad facilities should also be clearly shown on the submission (with distance and dimension information).
2. Crane rating sheets are to be provided showing cranes to be adequate for 150% of the lift. Crane and boom nomenclature is to be indicated.
3. Plans and computations are to be included with the submission showing weight of pick, safety factors and what work is being performed over NJTRO. Plans must also show a positive stop attachment and general plans of the existing and proposed facilities, showing complete and sufficient details with supporting data for the demolition or erection of the structure.
4. A location plan showing all physical limitations, restrictions or obstructions such as wires, poles, adjacent structures, etc., showing that the proposed swings are possible. In the event of any hoisting operation proposed to be adjacent to aerial lines, the Contractor shall furnish NJTRO with sufficient florescent orange rubber goods, as determined by NJTRO, to be installed as an aid in visually locating the aerial lines and as additional protection.
5. A data sheet shall be prepared listing the type, size and arrangements of slings, shackles, or other connecting equipment. Include copies of a catalog or information sheets of specialized equipment being used.
6. A complete lifting procedure is to be included, indicating the order of lifts and any repositioning of crane or cranes including reattachment of positive stop.
7. Temporary support of any components or intermediate stages is to be shown.
8. A time schedule of various stages must be provided as well as a schedule for the entire lifting procedure.

9. All bridge erection or demolition procedures submitted will be signed and sealed by a registered professional Engineer licensed in the State of New Jersey.
10. At least six (6) copies of the plan should be sent to Director of Right-of-Way Engineering, One Penn Plaza East, Newark, NJ 07105.
11. The Contractor is to be advised that they can expect a minimum thirty (30) day review period for this and any other shop drawing submissions.

### **MINIMUM STANDARDS FOR GEO-TECHNICAL INVESTIGATIONS ALONG THE RIGHT-OF-WAY**

Subsurface investigations made on or adjacent to the right-of-way should meet the minimum recommended practices as provided in Chapter 1, Volume 1, of the current American Railway Engineering association Manual for Railway Engineering. Additionally, the following requirements must be met:

- Borings shall be advanced using casing or mud rotary techniques. Use of hollow stem augers below the water table is prohibited.
- All borings shall be tremie grouted with non-shrink cement grout from the bottom to the top of the bore hole at completion. Subsequent minor surface settlement shall be back-filled with tamped earth, asphalt or finished concrete, as appropriate.
- No observation or monitoring wells shall be installed on railroad property without the prior express authorization of the Environmental Services Unit.
- No sampling of any kind shall be done on railroad property without the prior express authorization of the Environmental Services Unit.
- No work shall be done that interferes with operation and/or maintenance of the railroad unless specifically approved in the Temporary Access Permit.
- The crossing of tracks or use of tracks for or by personnel, equipment of material shall only be done under the protection of a qualified NJTRO representative.
- The presence of buried railroad or foreign utilities may or may not be known and any damage resulting from the investigation will be repaired as required, and all charges resulting from such damage shall be paid promptly by the Permittee in accordance with the terms of the Temporary Access Permit.
- In advance of the authorized investigation, the locations of proposed pits, boring location, or monitoring well location shall be marked out in the field to

review the site for possible location of buried utilities or conflict with operating systems.

A reproducible location plan of proposed boring layout, test pits' locations, or monitoring well locations will be submitted with the technical specification for the work for review and approvals prior to start of work. Detail of the plan shall be sufficient to permit review and comment by the Engineering and Environmental Services Departments. These plans and specifications shall be accompanied by a brief narrative of how the work will be carried out.

The location plan should provide from a licensed Land Surveyor the proposed State plane coordinates and approximate ground surface elevations of the work, and reference centerline alignment and profile of near tracks, support poles and guy anchors, existing foundations and overhead or undergrade wire, conduit, pipelines or structures. NJ TRANSIT uses State coordinate systems for horizontal control as appropriate and vertical datum based on Mean Sea Level equal to 0.0 feet in plan and nearest 0.1 feet in elevation.

Property information should be coordinated with the applicable Right-of-Way and Track Maps or Valuation Sheets. Copies of these maps can be obtained from the NJTRO Real Estate Department. These maps should be used to locate the work with respect to railroad stationing, structure number and mile post.

A draft summary Engineering Report shall be prepared signed and sealed by the licensed professional Engineer in charge of the work. Upon review and comment by NJTRO, three copies of the final report shall be submitted for record.

### **ADDITIONAL REQUIREMENTS FOR PIPELINE OCCUPANCIES**

The Contractor shall be responsible for compliance with all provisions of NJTRO Specification EP-2 and shall comply with all reasonable requests from NJTRO.

The Contractor shall be responsible to furnish all labor, materials and equipment necessary to install the casing and carrier pipes as referred to in the executed Occupancy Agreement and as shown on the approved contract documents. The Contractor shall be responsible for notification to the appropriate utility companies for surface markout and NJTRO shall be responsible for markout of its own facilities potentially affected by the installation.

If the jacking pit/boring equipment is constructed such that verbal communications are limited, universal hand signals shall be utilized and their meaning clearly understood between all employees. When visual contact between key operators and support Groundmen cannot be adequately maintained, two-way radio contact must be utilized.

The Contractor must provide material certifications for all material to be installed and must prepare and submit for review (allowing 30 calendar days) detailed drawings and supporting calculations (all signed and sealed by a licensed professional Engineer) showing the proposed methods of crossing; including jacking pit details, shoring, bracing, dewatering methods, pushing backstops, receiving pits, grade and alignment controls, catalog cuts on jacking equipment, and narrative methods for installing casing and carrier pipe. The Contractors must be prepared to work continuously and complete the jacking operation below the tracks once the live load influence line has been entered by the auger/casing.

The use of water or other liquids to facilitate conventional casing emplacement and soil removal is prohibited. If during installation, an obstruction is encountered which prevents installation of the pipe in accordance with the approved plans,, the pipe shall be abandoned in place and immediately filled with grout. A revised installation plan must be submitted for approval.

When water is known or expected to be encountered, a designed dewatering system with pumps of sufficient capacity shall be utilized to handle the flow in such a fashion which does not allow groundwater to affect the installation. When dewatering, close observation shall be maintained to detect any settlement or displacement of the embankments, tracks and facilities.

As part of the jacking operation, the Contractor shall be responsible for the completion of Survey Control Monitoring to verify track movement prior to, during, and at a point after completion. The survey monitoring procedure and location layout can be site-specific modified, but, must generally follow those as shown on the attached. The survey monitoring procedure must be completed and signed by a Licensed Land Surveyor.

## NJ TRANSIT SURVEY MONITORING PROCEDURES FOR PIPELINE OCCUPANCIES

<u>ACTIVITY</u>	<u>LOCATION OF SETTLEMENT POINTS</u>	<u>FREQUENCY</u>
Prior to installation and disturbance of the property.	The top of each rail at the centerline of crossing, 5', 10' and 25' on each side of the crossing or as directed by the Manager of Right-of-Way Engineering or his designee. When temporary track supports have been installed, only the running rails shall be monitored.	Take three (3) sets of reading with at least one (1) train passing the area between readings for a base level measurement. All readings to be measured to the nearest 0.001 ft.
Installation of the casing, grouting operation, and, or during dewatering operation.	All points noted above and as required by NJTRO on the Contractors approved dewatering plans.	Immediately prior to start and trains continuously during jacking, and week all dewatering activities for the first activities for the first seven (7) calendar days and then twice weekly.
At completion of jacking, as, necessary,	All points noted above.	After one (1) train, after five (5) after one (1) day, after one (1) after one (1) month or as directed by the Manager, Right-of-Way Engineering or his designee

Should the total changes in rail elevations for any pair of adjacent points exceed the established base elevations by 0.02 ft., the Surveyor shall immediately notify the Manager, Right-of-Way, Engineering or his designee. All readings shall be transmitted directly to the NJ TRANSIT Resident Engineer within twenty-four (24) hours of taking the measurement. Elevations shall be referenced to a U.S.G.S. benchmark and survey runs shall be reported with the proper closure errors. Readings and elevations shall be certified by a licensed Land Surveyor. Copies of the field data shall be maintained on-site by the Permittee's Engineer. Review of the survey data by NJ TRANSIT will be made at the end of the first month following the jacking operation to determine the need for additional elevation measurements.

**TRACK SURVEY MONITORING POINTS (TYPICAL FOR ALL TRACKS)**

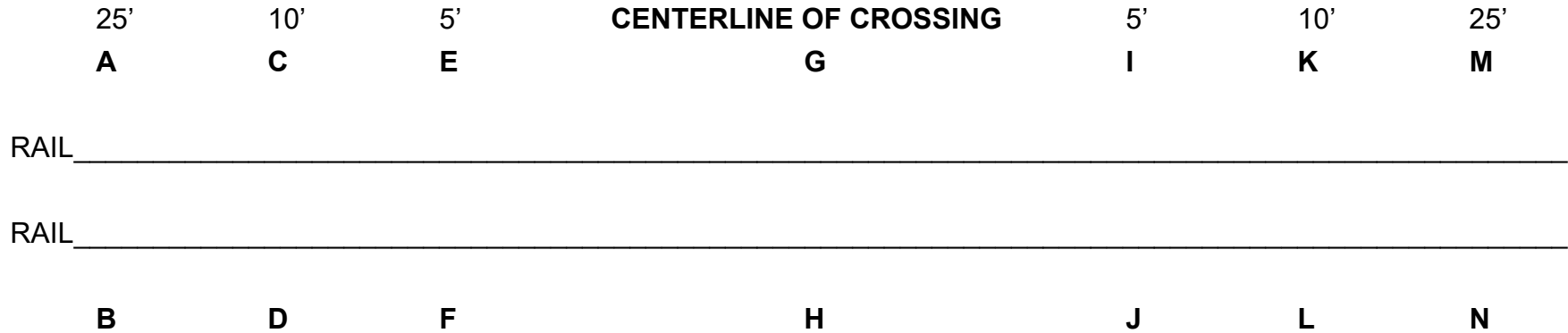

NOTE: All field markouts shall be accomplished using a paint or keel marker, chisel cuts are prohibited on the rail.



**B. SPECIFICATIONS REGARDING SAFETY AND PROTECTION OF RAILROAD TRAFFIC AND PROPERTY WHEN WORKING WITHIN THE NATIONAL RAILROAD PASSENGER CORPORATION (RAILROAD) RIGHT OF WAY**

In the following Specifications “Chief Engineer” shall, mean Railroad’s Vice President, Chief Engineer, “Railroad” shall mean the National Railroad Passenger Corporation, ‘and/or his/her duly authorized representative.

(1) **Pre-Entry Meeting:** Before entry of Permittee and/or Contractors onto Railroad’s property, a pre-entry meeting shall be held at which time Permittee and/or Contractors shall submit for written approval of the Chief Engineer, plans, computations and a detailed description of proposed methods for accomplishing the work, including methods for protecting Railroad’s traffic. Any such written approval shall not relieve Permittee and/or Contractor of their complete responsibility for the adequacy and safety of their operations.

(2) **Rules, Regulations and Requirements:** Railroad traffic shall be maintained at all times with safety and continuity, and Permittee and/or Contractors shall conduct their operations in compliance with all rules, regulations, and requirements of Railroad (including these Specifications) with respect to any work performed on, over, under, within or adjacent to Railroad’s property. Permittee and/or Contractors shall be responsible for acquainting themselves with such rules, regulations and requirements. Any violation of Railroad’s safety rules, regulations, or requirements shall be grounds for the immediate suspension of the Permittee and/or Contractor work, and the retraining of all personnel, at the Permittee’s expense.

(3) **Maintenance of Safe Conditions:** If tracks or other property of Railroad are endangered during the work, Permittee and/or Contractor shall immediately take such steps as may be directed by Railroad to restore safe conditions, and upon failure of Permittee and/or Contractor to immediately carry out such direction, Railroad may take whatever steps are reasonably necessary to restore safe conditions. All costs and expenses of restoring safe conditions, and of repairing any damage to Railroad’s trains, tracks, right-of-way or other property caused by the operations of Permittee and/or Contractors, shall be paid by Permittee.

(4) **Protection in General:** Permittee and/or Contractors shall consult with the Chief Engineer to determine the type and extent of protection required to insure safety and continuity of railroad traffic. Any Inspectors, Track Foremen, Track Watchmen, Flagmen, Signalmen, Electric Traction Linemen, or other employees deemed necessary by Railroad, at its sole discretion, for protective services shall be obtained from Railroad by Permittee and/or Contractors. The cost of same shall be paid directly to Railroad by Permittee. The provision of such employees by Railroad, and any other precautionary measures taken by Railroad, shall not relieve Permittee and/or Contractors from their complete responsibility for the adequacy and safety of their operations.

(5) **Protection for Work Near Electrified Track or Wire:** Whenever work is performed in the vicinity of electrified tracks and/or high voltage wires, particular care must be exercised, and Railroad's requirements regarding clearance to be maintained between equipment and tracks and/or energized wires, and otherwise regarding work in the vicinity of electrified tracks, must be strictly observed. No employees or equipment will be permitted to work near overhead wires, except when protected by a Class A employee of Railroad. **Permittee and/or Contractors must supply an adequate length of grounding cable (4/0 copper with approved clamps) for each piece of equipment working near or adjacent to any overhead wire.**

(6) **Fouling of Track or Wire:** No work will be permitted within twenty-five (25) feet of the centerline of track or the energized wire or have potential of getting within twenty-five (25) feet of track wire without the approval of the Chief Engineer's representative. Permittee and/or Contractors shall conduct their work so that no part of any equipment or material shall foul an active track or overhead wire without the written permission of the Chief Engineer's representative. **When Permittee and/or Contractors desire to foul an active track, they must provide the Chief Engineer's representative with their site-specific work plan a minimum of twenty-eight (28) calendar days in advance, so that, if approved, arrangements may be made for proper protection of Railroad.** Any equipment shall be considered to be fouling a track or overhead wire when located (a) within fifteen (15) feet from the centerline of the track or within fifteen (15) feet from the wire, or (b) in such a position that failure of same, with or without a load, would bring it within fifteen (15) feet from the centerline of the track or within fifteen (15) feet from the wire and requires the presence of the proper Railroad protection personnel.

If acceptable to the Chief Engineer's representative, a safety barrier (approved temporary fence or barricade) may be installed at fifteen (15) feet from centerline of track or overhead wire to afford the Permittee and/or Contractor with a work area that is not considered fouling. Nevertheless, protection personnel may be required at the discretion of the Chief Engineer's representative.

(7) **Track Outages:** Permittee and/or Contractors shall verify the time and schedule of track outages from Railroad before scheduling any of their work on, over, under, within, or adjacent to Railroad's right-of-way. Railroad does not guarantee the availability of any track outage at any particular time. Permittee and/or Contractors shall schedule all work to be performed in such a manner as not to interfere with Railroad operations. Permittee and/or Contractors shall use all necessary care and precaution to avoid accidents, delay or interference with Railroad's trains or other property.

(8) **Demolition:** During any demolition, the Contractor must provide horizontal and vertical shields, designed by a Professional Engineer registered in the state in which the work takes place. These shields shall be designed in accordance with the Railroad's specifications and approved by the Railroad, so as to prevent any debris from falling onto the Railroad's right-of-way or other property. A grounded temporary vertical protective barrier must be provided if an existing vertical protective barrier is removed during demolition. In addition, if any openings are left in an existing bridge deck, a protective fence must be erected at both ends of the bridge to prohibit unauthorized persons from entering onto the bridge.

(9) **Equipment Condition:** All equipment to be used in the vicinity of operating tracks shall be in “certified” first-class condition so as to prevent failures that might cause delay to trains or damage to Railroad’s property. No equipment shall be placed or put into operation near or adjacent to operating tracks without first obtaining permission from the Chief Engineer’s representative. **Under no circumstances shall any equipment or materials be placed or stored within twenty-five (25) feet from the centerline of an outside track, except as approved by the Site Specific Safety Work Plan.** To insure compliance with this requirement, Permittee and/or Contractors **must establish a twenty-five (25) foot foul line prior to the start of work** by either driving stakes, taping off or erecting a temporary fence, or providing an alternate method as approved by the Chief Engineer’s representative. Permittee and/or Contractors will be issued warning stickers which must be placed in the operating cabs of all equipment as a constant reminder of the twenty-five (25) foot clearance envelope.

(10) **Storage of Materials and Equipment:** No material or equipment shall be stored on Railroad’s property without first having obtained permission from the Chief Engineer. Any such storage will be on the condition that Railroad will not be liable for loss of or damage to such materials or equipment from any cause.

(11) **Condition of Railroad’s Property:** Permittee and/or Contractors shall keep Railroad’s property clear of all refuse and debris from its operations. Upon completion of the work, Permittee and/or Contractors shall remove from Railroad’s property all machinery, equipment, surplus materials, falsework, rubbish, temporary structures, and other property of the Permittee and/or Contractors and shall leave Railroad’s property in a condition satisfactory to the Chief Engineer.

(12) **Safety Training:** **All individuals, including representatives and employees of the Permittee and/or Contractors, before entering onto Railroad’s property or coming within twenty-five (25) feet of the centerline of the track or energized wire shall first attend Railroad’s Safety Contractor/Leasee Employee Training Class.** The Safety Orientation Class will be provided by Railroad’s Safety Representative at Permittee’s expense. A photo I.D. will be issued and must be worn/displayed while on Railroad property. All costs of complying with Railroad’s safety training shall be at the sole expense of Permittee. Permittee and/or Contractors shall appoint a qualified person as their Safety Representative. He/she shall continuously assure that all individuals comply with Railroad’s safety requirements. All safety training records shall be maintained with site specific work plan.

(13) **No Charges to Railroad:** It is expressly understood that neither these Specifications, nor any document to which they are attached, include any work for which Railroad is to be billed by Permittee and/or Contractors, unless Railroad gives a written request that such work be performed at Railroad’s expense.

## **C. SPECIFIC REQUIREMENTS OF CONSOLIDATED RAIL CORPORATION ("CONRAIL") FOR WORK ON ITS RIGHT OF WAY**

### **SCOPE**

It must be clearly understood that CONRAIL owns and uses its right of way for the primary purpose of operating a railroad. All work shall therefore be done in a manner such that the rail operations and facilities are not interfered with, interrupted or endangered. In addition, any facilities that are a result of the proposed work shall be located to minimize encumbrance to the right of way so that CONRAIL will have unrestricted use of its property for current and future operations.

The sponsor of the project shall be ultimately responsible for assuring that its agents, consultants, contractors and sub-contractors fully comply with the specifications contained herein. The term 'sponsor' used throughout these specifications shall mean the sponsor, its employees, its agents, consultants, contractors, sub-contractors, etc. The following terms and conditions shall apply to any project which requires performance of work on the right of way or other property of CONRAIL.

### **RIGHT OF ENTRY ON CONRAIL PROPERTY**

No entry upon CONRAIL property shall be permitted without the proper authorization by CONRAIL to the sponsor in the form of an agreement or a proper permit-to-enter prepared by CONRAIL. The applicant shall pay the associated fees and execute the permit-to-enter prior to entering CONRAIL property. The location and design of that portion of the access route to the project site that is on CONRAIL property shall be shown clearly on any plans for the project and approved by CONRAIL.

It is to be clearly understood that the issuance of a permit-to-enter does not constitute authority to proceed with any construction work. Construction cannot begin until a formal agreement between CONRAIL and the sponsor is executed, and the sponsor receives permission from CONRAIL's representative to proceed with the work.

### **INSURANCE**

In addition to any other forms of insurance or bonds required under the terms of any contract or specifications and except to the extent that any of the requirements of this section are expressly waived or revised in writing by CONRAIL, prior to the commencement of any work, Contractor, at his own cost and expense, shall maintain insurance of the following kinds and amounts and deliver to CONRAIL satisfactory evidence of such insurance as indicated herein:

#### **1. Public Liability Insurance**

Public Liability Insurance, including contractual liability insurance of not less than \$5,000,000 combined single limit for bodily injury and/or property damage for damages arising out of bodily injuries to or death of all persons in any one occurrence and for damage to or destruction of

property, including the loss of use thereof, in any one occurrence. CONRAIL shall be named as an additional insured under this insurance.

2. **Automobile Liability Insurance**

Automobile Liability Insurance with a limit of not less than \$5,000,000 combined single limit for bodily injury and/or property damage per occurrence. CONRAIL shall be named as an additional insured under this insurance.

3. **Workers' Compensation / Employers' Liability Insurance**

Employers' Liability and Occupational Disease Insurance with limits of \$1,000,000 each accident, \$1,000,000 policy limit and \$1,000,000 each employee. Such policy shall include a waiver of subrogation in favor of CONRAIL.

4. **General Contractor's Pollution Legal Liability Insurance**

General Contractor's Pollution Liability Insurance with limits of not less than \$5,000,000 per occurrence/ \$5,000,000 aggregate bodily injury, property damage and cleanup expenses resulting from pollution conditions. CONRAIL shall be named as an additional insured under this insurance.

5. **Railroad Protective Liability Insurance**

Should it be required, NJ TRANSIT will provide Railroad Protective Liability Insurance Coverage for this Contract.

**CHANGES IN RAILROAD FACILITIES**

Temporary and permanent changes of signal, communication, power transmission lines, trailers, drainage and other railroad facilities required in connection with the project to clear temporary and/or permanent work of the sponsor as shown on the approved construction plans, shall be made or caused to be made by CONRAIL at the sole cost and expense of the sponsor in accordance with CONRAIL's force account estimate. Any other changes made or services furnished by CONRAIL at the request of the sponsor shall be the sole cost and expense of the sponsor.

**PROTECTION OF RAILROAD OPERATIONS**

The sponsor shall conduct the work in such a manner as to safeguard the operations, facilities, right-of-way and property of CONRAIL. All work affecting the above items shall be subject to the approval of CONRAIL. The sponsor's operations adjacent to, over or under CONRAIL's tracks, facilities, right-of-way, and property shall be governed by CONRAIL's standards and by such other requirements as specified by CONRAIL's representative so as to insure the safe operation of trains, prevent delay to trains and insure the safety of all concerned, including the sponsor's forces.

An operating track shall be considered obstructed or fouled when any object is brought closer than fifteen (15) feet (4.6 m) horizontally from the centerline of track and projects above the top of tie or as determined by CONRAIL's representative. A power line shall be considered fouled when any object is brought to a point less than eight (8) feet (2.5 m) therefrom. A signal line shall be considered fouled when any object is brought nearer than six (6) feet (1.8 m) to any wire or cable. Cranes, trucks and other equipment shall be considered as fouling the track, power line or signal line when failure of equipment, whether working or idle, with or without load, will obstruct the track or other CONRAIL facilities.

Equipment used by the sponsor shall be in first-class condition to preclude any failure that would cause interference with the operation of CONRAIL trains or damage to its facilities. The sponsor's equipment shall not be placed or put in operation adjacent to the tracks or facilities of CONRAIL without obtaining clearance from CONRAIL's representative. All such equipment shall be operated by the sponsor in a manner satisfactory to CONRAIL. No equipment or material shall be stored on CONRAIL property.

In general, a hazard occurs and a flagman is necessary in the following circumstances: (1) the driving of sheeting or piles within twenty five (25) feet (7.6 m) of the tracks, (2) the removal or demolition of all or part of an overhead or adjacent structure, (3) the erection of any structural material, or (4) the performance of any other operation that could obstruct or foul (as described above) the tracks or other facilities of CONRAIL as determined by CONRAIL 's representative.

Minimum overhead and lateral clearances as specified by CONRAIL, shall be maintained during the performance of all work. Existing overhead and lateral clearances shall be maintained during construction unless a temporary reduction in clearance for construction purposes is approved, in writing, by CONRAIL. The sponsor shall erect a highly visible construction fence no closer than fifteen (15) feet (4.6 m) from the centerline of the track through the work area to insure that the lateral clearance requirement is being met.

All wire and attachments shall be treated as live unless notified by CONRAIL's representative that same have been grounded and de-energized. Particular attention shall be given to the use of hand lines containing metal strands which cannot be used when working near or above exposed live wires. When working over wires, tools and materials not in use shall be stored in a manner to prevent them from falling. Tools or materials shall not be thrown to or by men working over the wires. The sponsor shall be responsible for locating and protecting all underground facilities.

Painting and paint removal procedures shall be approved by CONRAIL and inspected by CONRAIL's representative prior to beginning the work over railroad right of way. The sponsor shall protect the track structure and railroad property from any material used in conjunction with performing the work. A flagman shall be required whenever the above described work fouls or is likely to foul the track, as previously defined.

The sponsor shall give notice to CONRAIL's representative at least fourteen (14) calendar days in advance of the time work is to be commenced. CONRAIL shall assign, at the sole cost and expense of the sponsor, conductors and/or flagmen, or other similar qualified employees to protect CONRAIL's trains and facilities when in the opinion of its representative, the construction

work will cause or may cause a hazard to CONRAIL facilities and the safe operation of trains. No operations of the sponsor shall be carried out without all the necessary protection to properly safeguard the work.

The minimum hours per day for railroad employees engaged in flagging service shall be eight (8) hours. The overtime rate will be charged for all time in excess of eight (8) hours. Flagmen are paid from the time they leave headquarters until they arrive back at headquarters. The travel time to and from project site is known as "deadheading" and is paid at full rate of pay, plus travel expenses. No conductor or flagman may remain on duty longer than twelve (12) hours in any twenty-four (24) hour period.

The providing of flagmen or inspectors or the taking of other precautionary measures, shall not, however, relieve the sponsor from liability for payment of damages caused by their operations. The sponsor must obtain permission from the flagman before fouling or obstructing any track.

The sponsor shall be responsible for damage to CONRAIL facilities or property arising out of the execution of its work. CONRAIL shall undertake any necessary repair work at the sole cost and expense of the sponsor. Billing for the work shall be in accordance with CONRAIL's standard billing procedures.

CONRAIL labor shall be charged to sponsor at actual rate plus amount paid for insurance, railroad retirement, excise tax, vacation allowance, holidays, health and welfare benefits, small tools, 401k payment and overhead in accordance with CONRAIL's standard billing procedures. Materials shall be charged to the sponsor at actual cost to CONRAIL plus transportation costs, handling expense and applicable taxes.

## **RAILROAD ENGINEERING AND INSPECTION**

CONRAIL, at its sole discretion, may assign an engineer or inspector for the general protection of railroad property and operations during the construction of the project. This inspection service shall be supplied at the sole cost and expense of the sponsor.

## **PAYMENT OF RAILROAD SERVICES**

It is a requirement that the sponsor shall reimburse CONRAIL in full for work undertaken by CONRAIL in accordance with any provision of these special requirements. Final contract payment shall not be made by the sponsor to its Contractor, Subcontractor, consultant or agent, until CONRAIL certifies that all railroad bills against them, if any, have been paid in full.

## **TEMPORARY GRADE CROSSING**

Under most circumstances, a grade crossing of our track will not be permitted. Should the sponsor demonstrate a necessity for a temporary grade crossing of CONRAIL's tracks, the sponsor shall be required to apply for and execute the standard private grade crossing agreement for each crossing required. Application for the crossing shall be made to CONRAIL at least twelve (12) weeks before the crossing is required and addressed to:

**Consolidated Rail Corporation**  
**3501 Island Ave.**  
**Philadelphia, PA 19153**  
**Attention: Robert J. Dempsey**  
**Manager, Real Estate Services**  
**Telephone: (215) 937-7562**

A letter size plan showing the location, size, construction details, and access to the requested crossing should accompany the letter of application. The plan shall be fully detailed and dimensioned with all CONRAIL facilities shown and referenced. The sponsor shall state the purpose for which the crossing is needed and the expected life of the crossing. All application fees, construction, maintenance, protection and removal costs shall be at the sole cost and expense of the sponsor. The roadbed and all other CONRAIL facilities will be restored to the original condition subject to the approval of CONRAIL's designated representative.

### **SHEETING AND SHORING REQUIREMENTS**

The following items are to be included in the design and construction procedures for all permanent and temporary facilities adjacent to CONRAIL tracks:

- 1) Footings for all piers, columns, walls or other facilities shall be located and designed so that any temporary sheeting and shoring for support of adjacent track or tracks during construction shall not be closer than ten (10) feet (3.0 m) from the centerline of the nearest track.
- 2) When excavation for construction of the above mentioned facilities is within the theoretical railroad embankment line (see CONRAIL Drawing SK-1, attached), interlocking steel sheet piling, driven prior to excavation, must be used to protect track stability. The use of trench boxes or similar devices is not acceptable. Soldier piling and lagging will be considered for supporting adjacent track(s) only when its use is approved by CONRAIL. Consideration for the use of soldier piling and lagging shall be made if the required penetration of steel sheet piling cannot be obtained and when dry, non-running, stable material will be encountered.
- 3) The sheeting shall be designed to support all lateral forces caused by the earth, railroad and other surcharge loads. The railroad loading to be applied is an E-80 loading. This loading consists of 80 Kip (356 KN) axles spaced five (5) feet (1.5 m) on centers. The lateral forces acting on the sheeting shall be computed as follows:
  - (a) The Rankine Theory shall be used to compute the active earth pressure due to the weight of the soil.
  - (b) The Boussinesq analysis shall be used to determine the lateral pressure caused by the railroad loading. The load on the track shall be taken as a strip load with a width equal to the length of the ties (8'-6" or 2.6 m). The vertical surcharge,  $q$  (psf), caused by each axle, shall be uniform and equal to the axle weight divided by the tie length



and the axle spacing (5'-0" or 1.5 m). For an E-80 loading, this results in:  $q = 80,000 / (8.5 \times 5) = 1882$  psf (90.1 KPa).

- (c) The horizontal pressure due to the live load surcharge at any point on the sheet piling wall is  $P_h$  and can be calculated by the following:  $P_h = (2q/\pi)(B \sin B \cos 2 \alpha)$  (see CONRAIL Drawing SK-2, attached).
- 4) Deflection design criteria is as follows:
    - (a) 1/2" (1.27 cm) maximum deflection for sheet piling ten (10) feet (3.0 m) from centerline of the nearest track.
    - (b) 1" (2.54 cm) maximum deflection for sheet piling greater than ten (10) (3.0m) feet from centerline of the nearest track.
    - (c) Use K (at-rest earth pressure) for design of all braced and tie-back excavations.
  - 5) The allowable stresses for the sheet piling and other steel members (wales, struts, etc.) shall be in accordance with AREA Chapter 15, Part 1. These allowable stresses may be increased ten percent (10%) due to the temporary nature of the installations. A factor of safety of at least 1.5 must be used on temporary sheeting for the embedment length (i.e. multiply calculated embedment depth by 1.5).
  - 6) Where soil or rock anchors are used, all anchors must be tested. Testing shall be in accordance with industry standards with ten percent (10%) of the anchors "Performance Tested" and all others "Proof Tested". All tie-back anchor stresses are to be in accordance with AREA Chapter 8, Part 20.5.7.
  - 7) Exploratory trenches, three (3) feet (0.9 m) deep and fifteen (15) inches (0.4 m) wide in the form of an "H" with outside dimensions matching the outside of sheeting dimensions are to be hand dug, prior to placing and driving steel sheeting, in areas where railroad underground installations are known to exist. These trenches are for exploratory purposes only and are to be backfilled with the backfill compacted immediately. This work must be done in the presence of CONRAIL's representative.
  - 8) Absolute use of track is required while driving sheeting within fifteen (15) feet (4.6 m) from centerline of a live track. The procedure for arranging the use of track shall be as outlined on pages Three and Four.
  - 9) Cavities adjacent to the sheet piling, created by the driving of sheet piling, shall be filled with sand and any disturbed ballast must be restored and tamped immediately.
  - 10) Sheet piling shall be cut off at the top of tie during construction. After construction and backfilling has been completed, piling within ten (10) feet (3.0 m) from centerline of track, or when bottom of excavation is below a line extending a 1:1 slope from end of tie to point of intersection with sheeting, shall be cut off eighteen (18) inches (0.5 m) below existing ground line and left in place.

- 11) Any excavation adjacent to track shall be covered and ramped and provided with barricades as required by CONRAIL. A lighted walkway with a handrail must be provided adjacent to the track for any excavation within ten (10) feet (3.0 m) of the centerline.
- 12) Final backfilling of excavation shall be as required by project specifications.
- 13) The sponsor is to advise CONRAIL of the time schedule of each operation and obtain approval of CONRAIL for all work to be performed adjacent to Conrail tracks so that it may be properly supervised by railroad personnel.
- 14) All drawings for temporary sheeting and shoring shall be prepared and stamped by a Registered Professional Engineer and shall be accompanied by complete design computations when submitted for approval.
- 15) Where physical conditions of design impose insurmountable restrictions requiring the placing of sheeting closer than specified above, the matter must be submitted to CONRAIL for approval of any modifications.
- 16) Five (5) copies of the submission are to be sent to Conrail's Area Engineer. The sponsor is advised to expect a minimum thirty (30) day review period from the day the submission is received by the Area Engineer.
- 17) CONRAIL's representative must be present at the site during the entire sheeting and shoring procedure period. The sponsor must notify the railroad representative at least seventy-two (72) hours in advance of the work. No changes will be accepted after that time.

## **ERECTION, HOISTING AND DEMOLITION REQUIREMENTS**

- 1) A plan showing the locations of cranes, horizontally and vertically, operating radii, with delivery or disposal locations shown. The location of all tracks and other railroad facilities should also be shown.
- 2) Crane rating sheets showing cranes to be adequate for 150% of the actual weight of the pick. A complete set of crane charts, including crane, counterweight, and boom nomenclature is to be submitted.
- 3) Plans and computations showing weight of picks must be submitted. Where beams are being removed over CONRAIL facilities, the weight shall include the weight of concrete or other material that will be included in each pick. Calculations shall be made from plans of the existing and/or proposed structure showing complete and sufficient details with supporting data for the demolition or erection of the structure.
- 4) If the sponsor can prove to CONRAIL that plans do not exist and weights must be calculated from field measurements, the field measurements are to be made under the supervision of the Registered Professional Engineer submitting the procedure and he

shall include sketches and estimated weight calculations with his procedure. If possible, field measurements shall be taken with a CONRAIL representative present. Weights shall include the weight of concrete, or other material that will be included in the lifts.

- 5) If the procedure involves either the cutting of steel or the bolting of joints which would affect CONRAIL operations, a detailed staging plan with estimated durations will be required.
- 6) A location plan showing all obstructions such as wires, poles, adjacent structures, etc., must be provided to show that the proposed lifts are clear of these obstructions.
- 7) A data sheet shall be prepared listing the type, size and arrangements of slings, shackles, or other connecting equipment. Include copies of a catalog or information sheets for specialized equipment.
- 8) A complete procedure is to be included, indicating the order of lifts and any repositioning or rehitching of the crane or cranes.
- 9) Demolition shield submittals must include a plan showing the details of the shield, a written installation and removal procedure and design calculations verifying the capacity of the shield. The shield should be designed for a minimum load of fifty (50) pounds/sq.ft. (245 kgs/sq.m.) plus the weight of the equipment, debris and any other load to be carried.
- 10) Temporary support of any components (overhead or undergrade) or intermediate stages is to be shown and detailed. A guardrail (railroad) will be required to be installed in a track where a temporary bent is located within twelve (12) feet (3.7 m) from the centerline of that track.
- 11) A time schedule of the various stages must be shown as well as a schedule for the entire lifting procedure.
- 12) All bridge erection or demolition procedures submitted will be prepared, signed and sealed by a Registered Professional Engineer.
- 13) Five (5) copies of the lifting procedures are to be sent to CONRAIL's Area Engineer. The sponsor is to expect a minimum thirty (30) day review period from the day the submission is received by the Area Engineer.
- 14) CONRAIL's representative must be present at the site during the entire demolition and erection procedure period. The sponsor must notify the railroad representative at least seventy-two (72) hours in advance of the work. No changes will be accepted after that time.
- 15) The name and experience of the employee supervising the operation must be supplied to CONRAIL.

# **OVERGRADE BRIDGE REQUIREMENTS**

## **CLEARANCES**

- 1) The minimum vertical clearance above the top of the higher rail shall be twenty three (23) feet (7 m) at all times. In areas where the railroad has been electrified with a catenary wire, and areas which are likely to be electrified, the minimum vertical clearance must be twenty four (24) feet, six (6) inches (7.5 m) above the top of the higher rail.
- 2) The minimum horizontal clearance measured from the centerline of track to the near face of the obstruction must be twenty (20) feet (6.1 m) for tangent track and twenty one (21) feet (6.4 m) for curves. See CONRAIL Standard Plan 48754-B, attached.
- 3) Whenever practicable, bridge structures must have the piers and abutments located outside of the railroad right of way. All piers located less than twenty five (25) feet (7.6 m) from the centerline of track require a crash wall designed in accordance with specifications outlined in the current AREA manual.
- 4) All piers should be located so that they do not interfere with ditches. Where special conditions make this impossible, an explanation of these conditions must be submitted with the drainage plans for review by CONRAIL.
- 5) The permanent clearances should be correlated with the methods of construction so that temporary construction clearances will not be less than the minimum allowed.
- 6) Bridge structures shall provide sufficient lateral and vertical clearance for anticipated future tracks, changes in track centers and raising of tracks for maintenance purposes. The locations of these tracks shall be determined by inquiry to CONRAIL.
- 7) The profile of the top of rail should be examined to determine if the track is in a sag at the location of the bridge. If the track is in a sag, the vertical clearance from the track to the bridge should be increased sufficiently to allow raising the track to remove the sag.
- 8) Plans for bridges must show dimensioned locations of all utilities which might be located on the railroad right of way.
- 9) Vertical and horizontal clearances must be adjusted so that the sight distance to railroad signals is not reduced from what is existing.
- 10) All proposed temporary clearances which are less than those listed above must be submitted to Conrail for review and must be approved by CONRAIL prior to construction.
- 11) Clearances are subject to the requirements of the state in which the construction takes place and must be approved by NJ TRANSIT and CONRAIL if less than those prescribed by law.

## **DRAINAGE**

- 1) Maintaining the existing drainage and providing for future drainage improvements is of the utmost importance. CONRAIL will give special attention to reviewing drainage details.
- 2) Drainage plans must be included with the general plans submitted to CONRAIL for approval. These plans must include hydrologic and hydraulic studies and computations showing the frequency and duration of the design storm used, as well as the method of analysis such as Soil Conservation Service or the Rational method. CONRAIL uses storms with a 100-year recurrence interval as the minimum design storm.
- 3) Lateral clearances must provide sufficient space for construction of the required track ditch parallel to the standard roadbed section. If the ditch cannot be provided, or the pier will interfere with the ditch, then a culvert of sufficient size must be provided. See CONRAIL Standard Plans 48754-B and 48747, attached.
- 4) Ditches and culverts must be sized to accommodate all increased run-off due to the construction and the increased size must continue to the natural outlet of the ditch. Ditches must be designed in accordance with good drainage engineering practices and must meet all local codes and ordinances.
- 5) No scuppers or other deck drains, roadway drainage, catch basins, inlets or outlets are permitted to drain onto Conrail property. Any variation of this policy must have the prior approval of CONRAIL. If an exception is ultimately granted, maintenance of such should not be CONRAIL's responsibility. Drainage from scuppers and deck drains must be conveyed through pipes, preferably to a point which is off CONRAIL property. If the drainage must be conveyed into a railroad ditch, calculations must be provided to CONRAIL which indicate the ability of the ditch to carry the additional runoff.
- 6) Additional drainage may require the installation of a pipe or pipes, new ditch or reprofiling of the existing ditch.

## **EROSION CONTROL**

- 1) Embankment slopes on CONRAIL property adjacent to the track must have a slope of 2:1 or less and be paved for a minimum of two (2) feet (0.6 m) beyond the outside edge of the bridge foundation structure. The purpose of the pavement is to minimize erosion of the embankment material and to reduce deterioration of the sub-grade material by drainage water. The pavement shall consist of a prepared sub-base and/or filter fabric with grouted rip-rap on the surface.
- 2) The general plans for the bridge should indicate the proposed methods of erosion control during construction and must specifically address means to prevent silt accumulation in ditches and culverts and to prevent fouling the track ballast and sub-ballast. If the plans do not show erosion control, the Contractor must submit a proposed method of erosion control and must have this method approved by CONRAIL prior to beginning any grading on the site.

- 3) Existing track ditches must be maintained at all times throughout the construction period. After the construction has been completed, all erosion and siltation must be removed and the ditches must be restored.
- 4) CONRAIL's approval of drainage and erosion control plans will not relieve the sponsor submitting these plans from ultimate responsibility for a satisfactory plan.

## **REFERENCES**

- 1) In areas where underground utilities may be affected, CONRAIL's C.E. 8, "Specifications for Pipeline Occupancy" will govern.
- 2) In areas where power or communication lines will be affected, CONRAIL's C.E. 4, "Specifications for Wire, Conduit and Cable Occupations" will govern.

# APPENDIX E

## AGREEMENT BETWEEN CONTRACTOR AND ARTIST

This Agreement made the day of \_\_\_\_\_ 20\_\_\_\_,  
between \_\_\_\_\_ (hereinafter referred to as  
"Contractor") having its principal office at \_\_\_\_\_ and  
\_\_\_\_\_ (hereinafter referred to as  
the "Artist").

### WITNESSETH:

WHEREAS, pursuant to N.J.S.A. 52:16A-29 et seq., NJ TRANSIT is desirous of incorporating fine arts in the following project:

**Name of Project:**

**Location of Project:**

WHEREAS, the Artist has submitted a proposal to design such Artwork, under the terms and conditions set forth herein and in accordance with the following Attachments which are hereby made a part of this Agreement:

**Appendix "1"** - Federal Contract Requirements

**Attachment "A"** - Fees, Materials and Payment Schedule

**Attachment "B"** - Progress Schedule

**Attachment "C"** - Scope of Work

**Attachment "D"** - Artist Proposal for Artwork

The proposal to design and deliver the Artwork shall be incorporated in this Agreement as Attachment "D". To the extent that this contract contains requirements different from the proposal, the contract shall control.

NOW, THEREFORE, in consideration of the mutual promises and undertakings contained herein, the parties covenant and agree as follows:

1. The Artist shall provide all design, engineering, project coordination and project management services which are necessary in the performance of work required by this Agreement. The Artist is responsible for all of the Artist's travel and transportation expenses associated with the performance of this Agreement.

2. The Artist is responsible for the provision of the Artwork design, documents and submittals which include engineering drawings and lighting design, physical layout, complete fabrication, transportation, installation and documentation of the Artwork. The Artist shall ensure that all structural elements of the Artwork and mounting devices are designed and certified by an engineer licensed in the State of New Jersey. The Artist agrees to provide all necessary lighting fixtures and fixture-ready attachments including cords and plug connections, bulbs and mounting bracket/tracks. The Artist shall consult with the project architect prior to procurement of lighting equipment for review and approval of manufacturer, type and number of fixtures, and to ensure proper interface with electrical source(s) in the building.

3. It shall be Contractor's responsibility to prepare and make available the site for preparation, modification, or other necessary work by the Artist and Contractors performing services relevant to the Artwork.

4. Contractor and NJ TRANSIT, through their authorized representative or representatives, may at reasonable times and on reasonable notice, set up mutually convenient times to review the Artwork while in the process of being designed, completed and installed. Such visits shall be preceded by a telephone communication to the Artist with verbal confirmation by the Artist.

5. The Artist will complete the Artwork in accordance with the Progress Schedule contained herein in Attachment B.

In the event the installation is not properly completed by the agreed-upon date, except for causes beyond the Artist's control (such as, but not limited to fire, theft, strikes, lock-outs, materials shortages, illness and acts of God) and as liquidated damages (not as a penalty), Contractor may deduct from the amount due Artist \$\_\_\_\_\_ for each day's delay encountered until installation is properly completed, or the Agreement terminated. The Artist may request Contractor, not later than ten (10) calendar days before the installation date set forth in this contract, for an extension of that installation date. Such extension, if granted, must be in writing. If the site is not available to receive the Artwork when the Artist has completed on schedule, Contractor will pay for all excess costs of storage and transportation. Contractor may at its own expense take possession of the Artwork and store same at its own site. In that event, Contractor shall bear risk of loss. Subsequent delivery and installation shall be in accordance with the terms stated herein.

6. The Artist shall regularly confer with Contractor's Project Management staff and attend required meetings in order to verify and insure that the Artwork will be incorporated into the project at the proper time. Meetings shall be held at a time which is mutually convenient for Contractor and the Artist.

7. The Artist must take all reasonable precautions to protect the property of NJ TRANSIT and all others at and adjacent to the installation site of the work. The Contractor will be responsible for adequate protection of the public during installation.

8. To the extent possible, NJ TRANSIT will not intentionally remove, alter, modify or change the Artwork unless it is necessary for the preservation, safety, repair, destruction or renovation of the premises in which the Artwork is installed as determined by NJ TRANSIT at its sole discretion. NJ TRANSIT shall not otherwise remove, alter, modify, destroy or change the Artwork without the agreement of the Artist. Such agreement shall be governed by the applicable provisions of 17 U.S.C.A. 113. The Artist further waives any rights he may have against and agrees not to institute suit against NJ TRANSIT for any removal, alterations, modifications, damage, destruction or changes that may occur to the Artwork in the event that the premises are no longer under the ownership, supervision, or control of NJ TRANSIT. The Artist hereby agrees to provide a suggested maintenance schedule for the Artwork to NJ TRANSIT at the time of completion of the project. These obligations and waivers shall survive the termination of this Agreement.



9. The Artist agrees that for one year following the installation and acceptance of the Artwork, he shall correct, without charge, any defects in the Artwork which require repair or correction.

10. A plaque containing the title of the Artwork, name of the Artist, and recognition of NJ TRANSIT shall be publicly displayed and identified with the Artwork. Such plaque shall be provided by the Artist upon completion of the work. The design and content of the plaque is subject to approval in writing by NJ TRANSIT.

11. The Artist agrees to register the completed Artwork for copyright immediately upon acceptance by NJ TRANSIT. Copyright notice shall appear on the work and project plaque. The Artist grants to NJ TRANSIT and the NJSCA the non-exclusive right to photograph the Artwork and otherwise reproduce it in film, tape, digital format, or any other reproductive media, and publish the same with proper identification of copyright, including identification of Artist. With the exception of the above listed parties, Artist reserves to himself all copyrights in the work, the preliminary design, and any incidental works, made in the creation of the work.

The Artist further agrees that the Artwork completed under this Agreement is a unique work and that copies or editions of the Artwork will not be created and installed at any other location worldwide.

NJ TRANSIT will consult with the Artist prior to the production of any commercially marketable items which depict the Artwork and are intended to be offered for sale to the general public.

12. The Artist agrees to supply NJ TRANSIT and the NJSCA with full archival documentation of the completed Artwork including, but not limited to 35mm slides, black and white and color photographs, original presentation maquette, original drawings and a written physical description. Such documentation is to be placed in the archives of the NJSCA. The submitted material shall not be offered for sale at any time.

This documentation is to be supplied by the Artist not later than thirty (30) calendar days after installation of the Artwork and must comply with the NJSCA documentation format for visual artwork.

13. NJ TRANSIT may elect to publicly dedicate/unveil the Artwork and the Artist will attend said dedication/unveiling, upon adequate written notice from NJ TRANSIT, unless excused by NJ TRANSIT.

14. Contractor/NJ TRANSIT may terminate this Agreement for convenience by giving written notice to the ARTIST of such termination sent to the ARTIST at the address set forth in paragraph 34. In that event the ARTIST shall be paid for all reasonable costs of work properly completed on the date of termination including all reasonable costs of materials and equipment purchased and/or rented to date, and any penalties due on leased space and subcontracts for fabrication of the ARTWORK.

15. Contractor/NJ TRANSIT may terminate this Agreement for cause at any time if the ARTIST has materially failed to comply with terms of the Agreement. In the event of such failure, NJ TRANSIT shall promptly give written notification to the ARTIST of its intent to terminate and the reasons thereof. The ARTIST shall have ten (10) calendar days, or such additional time as NJ TRANSIT may grant, after receipt of notice to cure its failure. If the failure is not cured to the satisfaction of NJ TRANSIT, the ARTIST shall be held in breach of contract and the contract terminated (in whole or in part) effective immediately.

After receipt of notice of termination, the ARTIST shall not incur any new obligations without the approval of NJ TRANSIT and shall cancel as many outstanding obligations as possible. NJ TRANSIT will evaluate each obligation deemed non-cancellable by the ARTIST in order to determine its eligibility for inclusion in compensable costs.

Compensation shall be made for work properly completed and approved by NJ TRANSIT prior to the date of termination.

If this Agreement or any part thereof is terminated for cause, NJ TRANSIT may procure services similar to those so terminated. The ARTIST shall be liable to NJ TRANSIT for any reasonable excess costs incurred for such similar services.

No damages of any nature shall be claimed against NJ TRANSIT in the event it exercises this right of termination. The rights and remedies available to in this section shall not be exclusive and are in addition to any other rights and remedies provided by law or under this Agreement.

If, after notice of termination of this Agreement under the provisions of this section, it is determined for any reason that the ARTIST was not in default under the provisions of this section, or that the default was excusable under the provisions of this section, the rights and obligations of the parties shall be the same as if the notice of termination had been issued pursuant to Section 14.

16. Ownership of all materials, designs and drawings related to the Artwork, originated and prepared for NJ TRANSIT after the date of signing of this Agreement, shall rest with NJ TRANSIT, and shall be submitted by the Artist to the project archives of the NJSCA. The Artist shall provide NJ TRANSIT and the NJSCA with copies of all pertinent maintenance information and structural design information in accordance with the requirements of this Agreement.

17. a. With the execution of this Agreement, Contractor will ensure that the Artist will receive a full review and discussion of plans to date and complete background information relevant to all considerations affecting the Artist's responsibility to fulfill its obligations. In particular, Contractor shall make available to the Artist all necessary background and orientation materials, adequate notice of scheduled presentations, meetings dealing with matters affecting the Artist's participation in construction schedules, deadlines and plans affecting the Artist's installation of his/her work, and shall invite the Artist and afford the Artist full participation at all such presentations and meetings.

b. The quality of the finishes of the completed Artwork shall be as described by the Artist in his Design Development Plans unless Contractor and NJ TRANSIT have authorized necessary changes. NJ TRANSIT reserves the right to reject the completed Artwork if it does not meet the stated specifications of the Design Development Plans.

18. The Contracting Officer for this Agreement shall be: \_\_\_\_\_, (NAME OF CONTRACTING OFFICER). Wherever this Agreement requires any notice to be given to or by Contractor, or any determination to be made by Contractor, the Contracting Officer or his Designee shall represent and act for the Contractor.

19. The Artist shall schedule any on-site activities with Contractor, and will provide notice of on-site activities to Contractor and NJ TRANSIT.

20. The Artist's status shall be that of an independent contractor and not as agent or employee of Contractor or NJ TRANSIT.

21. The Artist agrees not to assign this Agreement in whole or in part, or any moneys hereunder, without the prior written approval of NJ TRANSIT. Following installation of the artwork and its acceptance by NJ TRANSIT, and acceptance of the overall project, the Contractor will assign this Agreement and all its rights hereunder to NJ TRANSIT.

22. The Artist agrees that in the performance of this Agreement he will obey, abide and comply with applicable Federal, State, County and Municipal laws and regulations.

23. If incorporated in a state other than the State of New Jersey, the Artist shall promptly file with the Secretary of State an application for a Certificate of Authority to do business in the State of New Jersey and shall comply with the provisions of the laws of the State of New Jersey in that regard.

24. This Agreement shall be governed by and construed and the rights and obligations of the parties hereto shall be determined in accordance with the laws of the State of New Jersey. The courts of New Jersey Shall have sole jurisdiction over any suits brought concerning this Agreement.

25. The Artist hereby covenants and agrees to take, use, provide and make all proper and necessary and sufficient precautions, safeguards and protections against the occurrence or happening of any accident, injuries, damages or hurt to any person or property during the progress of the work herein covered and to indemnify, defend, and save harmless the Contractor and NJ TRANSIT, its officers, agents, servants and employees for the payment of all sums of money by reason of all, or any, such accidents, injuries, damages or hurt that may occur upon or about such work and all fines, penalties and loss incurred for or by reason of the violation of any ordinance, regulation, or statute, while the said work is in progress.

26. The risk of loss to the Artwork shall remain on the Artist at all times until the Artwork is delivered to Contractor. The Artist shall ensure that All Risk insurance on the Artwork, which shall protect the Artist's, Contractor and NJ TRANSIT's interests, is carried by the Artist or the Artist's fabricators and other subcontractors during the period of fabrication.

27. The Artist will carry Comprehensive General Liability insurance in the amount of \$5,000,000 Combined Single Limit for each occurrence. Such insurance shall name NJ TRANSIT, Contractor, (LIST OTHER INSURED) as additional insureds. This insurance to provide coverage during the period of fabrication and installation and until the installation is accepted in writing by Contractor.

The certificate of such insurance shall be submitted to the Contractor and NJ TRANSIT upon signing of this Agreement and shall be kept current through acceptance of the artwork.

28. The parties to this contract do hereby agree that the provisions of N.J.S.A. 10:2-1 through 10:2-4, dealing with discrimination in employment on public contracts, and the rules and regulations promulgated pursuant thereunto, are hereby made a part of this contract and are binding upon them. The Artist further agrees to comply with the requirements of N.J.S.A. 10:5-31, et seq., and all rules and regulations promulgated thereunder.

For the purpose of this Section 28, and only this Section 28 of this Agreement the "Public Agency Compliance Officer" referenced below is NJ TRANSIT's VP Civil Rights & Diversity Programs and the "Public Agency" is NJ TRANSIT and the Contractor is the Artist.

During the performance of this contract, the Contractor agrees as follows: The Contractor or subcontractor, where applicable, will not discriminate against any employee or applicant for employment because of age, race, creed, color, national origin, ancestry, marital status, sex, affectional or sexual orientation, nationality, gender identity or expression, or disability. The Contractor will take affirmative action to ensure that such applicants are recruited and employed, and that employees are treated during employment, without regard to their age, race, religion, color, national origin, ancestry, marital status, sex, affectional or sexual orientation. Such action shall include but not be limited to the following: employment, upgrading, demotion, or transfer; recruitment or recruitment advertising; layoff or termination; rates of pay or other forms of compensation; and selection for training, including apprenticeship. The Contractor agrees to post in conspicuous places, available to employees and applicants for employment, notices to be provided by the Public Agency Compliance Officer setting forth provisions of this non-discrimination clause;

The Contractor or subcontractor, where applicable, will in all solicitations or advertisements for employees placed by or on behalf of the Contractor, state that all qualified applicants will receive consideration for employment without regard to age, race, religion, color, national origin, ancestry, marital status, sex, affectional or sexual orientation;

The Contractor or subcontractor, where applicable, will send to each labor union or representative of workers with which it has a collective bargaining agreement or other contract or understanding, a notice, to be provided by the agency contracting officer advising the labor union or workers' representative of the Contractor's commitments under this act and shall post copies of the notice in conspicuous places available to employees and applicants for employment.

The Contractor or subcontractor, where applicable, agrees to comply with any regulations promulgated by the Treasurer pursuant to P.L. 1975, c.127, as amended and supplemented from time to time and the Americans with Disabilities Act.

The Contractor or subcontractor agrees to attempt in good faith to employ minority and female workers consistent with the applicable county employment goals prescribed by N.J.A.C. 17:27-5.2 promulgated by the Treasurer pursuant to P.L. 1975, c.127, as amended and supplemented from time to time or in accordance with a binding determination of the applicable county employment goals determined by the Affirmative Action Office pursuant to N.J.A.C. 17:27-5.2 promulgated by the Treasurer pursuant to P.L. 1975, c.127, as amended and supplemented from time to time.

The Contractor or subcontractor agrees to inform in writing appropriate recruitment agencies in the area, including employment agencies, placement bureaus, colleges, universities, labor unions, that it does not discriminate on the basis of age, creed, color, national origin, ancestry, marital status, sex, affectional or sexual orientation, nationality, gender identity or expression, or disability and that it will discontinue the use of any recruitment agency which engages in direct or indirect discriminatory practices.

The Contractor or subcontractor agrees to revise any of its testing procedures, if necessary, to assure that all personnel testing conforms with the principles of job-related testing, as established by the statutes and court decisions of the State of New Jersey and as established by applicable Federal law and applicable Federal court decisions.

The Contractor or subcontractor agrees to review all procedures relating to transfer, upgrading, downgrading and layoff to ensure that all such actions are taken without regard to age, creed, color, national origin, ancestry, marital status, sex, affectional or sexual orientation, nationality, gender identity or expression, or disability and conform with the applicable employment goals, consistent with the statutes and court decisions of the State of New Jersey, and applicable Federal law and applicable Federal court decisions.

The Contractor and its subcontractors shall furnish such reports or other documents to the Affirmative Action Office as may be requested by the office from time to time in order to carry out the purposes of these regulations, and public agencies shall furnish such information as may be requested by the Affirmative Action Office for conducting a compliance investigation pursuant to Subchapter 10 of the Administrative Code (N.J.A.C. 17:27).

29. The New Jersey prevailing wage laws are hereby made a part of this contract. The Artist's signature on the proposal and on this Agreement is his guarantee that neither he nor any subcontractors he might employ to perform work are listed by or are recorded in the New Jersey Department of Labor as one who has failed to pay prevailing wages in accordance with the provisions of the Prevailing Wage Act.

30. The Artist does hereby warrant and represent that this Agreement has not been solicited or secured, directly or indirectly, in a manner contrary to the laws of the State of New Jersey or of the United States and that said laws have not been violated as they relate to the procurement or the performance of this Agreement by any conduct, including the paying or giving of any fee, commission, compensation, gift, gratuity or consideration of any kind, directly or indirectly, to any NJ TRANSIT Contractor, or State of New Jersey employee, officer or official.

31. The Artist warrants and represents that no person has been employed to solicit or secure this contract in violation of any other laws and further represents that all applicable laws and regulations shall be complied with in the performance of this contract.

32. Prohibited Interest: No member, officer, or employee of NJ TRANSIT or its subsidiaries shall have any interest, direct or indirect, in this Agreement or the proceeds thereof. No former member, officer or employee of NJ TRANSIT or its subsidiaries who, during his tenure, had a direct, substantial involvement with matters that are closely related to this Agreement, shall have any interest, direct or indirect, in this Agreement or the proceeds thereof.

33. Release of Claims: It is agreed the Artist acceptance of final payment from Contractor/NJ TRANSIT shall release in full all claims and liability of whatsoever nature against Contractor and NJ TRANSIT for anything done or furnished or in any manner growing out of the performance of this Contract except such claims as may specifically excepted in writing by the Artist from the operation of such release.

34. All notices should be sent certified mail, return receipt requested, to the parties at the addresses listed below:

**(Name and Address of Contractor)**

and;

**(Name and Address of Artist)**

35. All changes to this Agreement shall be in writing and signed by the Contractor and the Artist.

36. Project Close-Out: Submissions required prior to final payment, include, but are not limited to, the following items:

- (1) Certificate of Final Acceptance,
- (2) Final Release of Claims,
- (3) Affidavit of Payment of Debts and Claims,
- (4) Affidavit of Release of Liens,
- (5) Final Certificate of Payment

IN WITNESS WHEREOF, Contractor and the Artist have executed this Agreement the day and year above written.

**ARTIST**

\_\_\_\_\_  
Witness

By \_\_\_\_\_  
Artist

**CONTRACTOR**

\_\_\_\_\_  
Witness

By: \_\_\_\_\_  
Title

## APPENDIX 1

### FEDERAL CONTRACT REQUIREMENTS

**1. NO FEDERAL GOVERNMENT OBLIGATIONS TO THIRD PARTIES:** The Artist agrees that, absent the Federal Government's express written consent, the Federal Government shall not be subject to any obligations or liabilities to any subrecipient, any third party contractor, or any other person not a party to the contract in connection with the performance of the project. Notwithstanding any concurrence provided by the Federal Government in or approval of any solicitation, subagreement, or third party contract, the Federal Government continues to have no obligations or liabilities to any party, including the subrecipient and third party contractor.

**2. FALSE OR FRAUDULENT STATEMENTS AND CLAIMS:**

A.) The Artist recognizes that the requirements of the Program Fraud Civil Remedies Act of 1986, as amended, 49 U.S.C. § 3801 et seq. and USDOT regulations, "Program Fraud Civil Remedies," 49 C.F.R. Part 31, apply to its actions pertaining to the project. Accordingly, by signing the Agreement, the Artist certifies or affirms the truthfulness and accuracy of any statement it has made, it makes, or it may make pertaining to the Agreement. In addition to other penalties that may be applicable, the Artist also acknowledges that if it makes a false, fictitious, or fraudulent claim, statement, submission, or certification, the Federal Government reserves the right to impose the penalties of the Program Fraud Civil Remedies Act of 1986, as amended, on the Artist to the extent the Federal Government deems appropriate.

B.) The Artist also acknowledges that if it makes a false, fictitious, or fraudulent claim, statement, submission, or certification to the Federal Government in connection with an urbanized area formula project financed with Federal Assistance authorized by 49 U.S.C. §5307, the Government reserves the right to impose on the Artist the penalties of 18 U.S.C. § 1001 and 49 U.S.C. §5307(n)(1), to the extent the Federal Government deems appropriate.

**3. EXCLUSIONARY OR DISCRIMINATORY SPECIFICATIONS:** Apart from inconsistent requirements imposed by Federal statute or regulations, the Artist agrees that it will comply with the requirements of 49 U.S.C. § 5323(h)(3) by refraining from using any Federal Assistance awarded by FTA to support procurements using exclusionary or discriminatory specifications.

**4. INTERESTS OF MEMBERS OF OR DELEGATES TO CONGRESS:** No member of or delegate to the Congress of the United States shall be admitted to any share or part of this Agreement or to any benefit arising therefrom.

**5. CERTIFICATION OF DEBARMENT AND SUSPENSION:** During the performance of this Agreement, the Artist must be in compliance with the requirements of the United States Department of Transportation, 49 C.F.R. Part 29, and FTA Circular 2015.1. The attached Exhibit sets forth detailed requirements and is hereby made a part of this Agreement.

**6. CIVIL RIGHTS:** During the performance of this Agreement, the Artist, for itself, its assignees and successors in interest (hereinafter referred to as the "Artist") agrees as follows:

A.) Compliance with Regulations: The Artist shall comply with the Regulations relative to nondiscrimination in federally-assisted programs of the United States Department of Transportation (hereinafter, "USDOT") Title 49, Code of Federal Regulations, Part 21, as they may be amended from time to time (hereinafter the "Regulations"), which are herein incorporated by reference and made a part of this Agreement.

B.) Nondiscrimination: In accordance with Title VI of the Civil Rights Act, as amended, 42 U.S.C. § 2000d, section 303 of the Age Discrimination Act of 1975, as amended, 42 U.S.C. § 6102, section 202 of the Americans with Disabilities Act of 1990, 42 U.S.C. § 12132, and Federal transit law at 49 U.S.C. § 5332, the Artist agrees that it will not discriminate against any employee, applicant or in the selection and retention of subcontractors, including procurements of materials and leases of equipment for employment because of race, color, religion, national origin, sex, age, or disability.. The Artist shall not participate either directly or indirectly in the discrimination prohibited by Section 21.5 of the Regulations, including employment practices when contract covers a program set forth in Appendix B of the Regulations.

C.) Solicitations for Subcontracts Including Procurements of Materials and Equipment: In all solicitations either by competitive bidding or negotiation made by the Artist for work to be performed under a subcontract, including procurements of materials or leases of equipment, each potential subcontractor or supplier shall be notified by the Artist of the Artist's obligations under this Agreement and the Regulations relative to nondiscrimination on the grounds of race, religion, color, sex, age, national origin or disability.

D.) Equal Employment Opportunity

The following equal employment opportunity requirements apply to the underlying contract:

(1) Race, Color, Religion, National Origin, Sex

In accordance with Title VII of the Civil Rights Act, as amended, 42 U.S.C. § 2000e, and Federal transit laws at 49 U.S.C. § 5332, the Artist agrees to comply with all applicable equal employment opportunity requirements of U.S. Department of Labor (U.S. DOL) regulations, "Office of Federal Contract Compliance Programs, Equal Employment Opportunity, Department of Labor," 41 C.F.R. Parts 60 et seq., (which implement Executive Order No. 11246, "Equal Employment Opportunity," as amended by Executive Order No. 11375, "Amending Executive Order 11246 Relating to Equal Employment Opportunity," 42 U.S.C. § 2000e note), and with any applicable Federal statutes, executive orders, regulations, and Federal policies that may in the future affect construction activities undertaken in the course of the Project. The Artist agrees to take affirmative action to ensure that applicants are employed, and that employees are treated during employment, without regard to their race, color, religion, national origin, sex, sexual orientation, gender identity or age. Such action shall include, but not be limited to, the following: employment, upgrading, demotion or transfer, recruitment or recruitment advertising, layoff or termination; rates of pay or other forms of compensation; and selection for training, including apprenticeship. In addition, the Artist agrees to comply with any implementing requirements FTA may issue.

(2) Age

In accordance with section 4 of the Age Discrimination in Employment Act of 1967, as amended, 29 U.S.C. § 623 and Federal transit law at 49 U.S.C. § 5332, the Artist agrees to refrain from discrimination against present and prospective employees for reason of age. In addition, the Artist agrees to comply with any implementing requirements FTA may issue.

(3) Disabilities

In accordance with section 102 of the Americans with Disabilities Act, as amended, 42 U.S.C. § 12112, the Artist agrees that it will comply with the requirements of U.S. Equal Employment Opportunity Commission, "Regulations to Implement the Equal Employment Provisions of the Americans with Disabilities Act," 29 C.F.R. Part 1630, pertaining to employment of persons with disabilities. In addition, the Artist agrees to comply with any implementing requirements FTA may issue.

E.) Information and Reports: The Artist shall provide all information and reports required by the Regulations or directives issued pursuant thereto, and shall permit access to its books, records, accounts, other sources of information, and its facilities as may be determined by NJ TRANSIT or the FTA to be pertinent to ascertain compliance with such Regulations, orders and instruction. Where any information is required or an Artist is in the exclusive possession of another who fails or refuses to furnish this information, the Artist shall so certify to NJ TRANSIT, or the FTA, as appropriate, and shall set forth what efforts it has made to obtain the information.

F.) Sanctions for Noncompliance: In the event of the Artist's noncompliance with the nondiscrimination provisions of this Agreement, NJ TRANSIT shall impose such contract sanctions as it or the FTA may determine to be appropriate, including but not limited to:

1.) Withholding of payments to the Artist under the Agreement until the Artist complies;  
and/or

2.) Cancellation, termination or suspension of the Agreement, in whole or in part.

G.) Incorporation of Provisions: The Artist shall include the provisions of Paragraphs A through F of this Section in every subcontract, including procurements of materials and leases of equipment, unless exempt by the Regulations, or directives issued pursuant thereto. The Artist shall take such action with respect to any subcontract or procurement as NJ TRANSIT or the FTA may direct as a means of enforcing such provisions including sanctions for noncompliance: provided, however, that, in the event an Artist becomes involved in, or is threatened with, litigation with a subcontractor or supplier as a result of such direction, the Artist may request NJ TRANSIT to enter into such litigation to protect the interests of NJ TRANSIT and, in addition, the Artist may request NJ TRANSIT to enter into such litigation to protect the interest of the United States.

**7. CONTRACT WORK HOURS AND SAFETY STANDARDS:** During the performance of this Agreement, the Artist, for itself, its assignees and successors in interest (hereinafter referred to as the "Artist") agrees as follows:



A.) Overtime Requirements: No Artist or subcontractor contracting for any part of the contract work which may require or involve the employment of laborers or mechanics shall require or permit any such laborer or mechanic in any work week in which he or she is employed on such work to work in excess of forty hours in such work week unless such laborer or mechanic receives compensation at rate not less than one and one-half times the basic rate of pay for all hours worked in excess of forty hours in such work week.

B.) Violation; Liability for Unpaid Wages; Liquidated Damages: In the event of any violation of the clause set forth in subparagraph (b)(1) of 29 C.F.R. Part 5.5, the Artist and any subcontractor responsible therefore shall be liable for the unpaid wages. In addition, such Artist and subcontractor shall be liable to the United States (in case the work done under contract for the District of Columbia or a territory, to such district or to such territory), for liquidated damages. Such liquidated damages shall be computed with respect to each individual laborer or mechanic, including watchmen and guards, employed in violation of the clause set forth in subparagraph (b)(1) of 29 C.F.R. Part 5.5 in the sum of \$25 for each calendar day on which such individual was required or permitted to work in excess of the standard work week of forty hours without payment of the overtime wages required by the clause set forth in subparagraph (b)(1) of 29 C.F.R. Part 5.5.

C.) Withholding for Unpaid Wages and Liquidated Damages: The Contractor, on behalf of USDOT or NJ TRANSIT, shall upon its own action or upon written request of an authorized representative of the Department of Labor withhold or cause to be withheld, from any monies payable on account of work performed by the Artist or subcontractor under any such contract or any other Federal contract with the same Artist, or any other Federally-assigned contract subject to the Contract Work Hours and Safety Standards Act, which is held by the same Artist, such sums as may be determined to be necessary to satisfy any liabilities of such Artist or subcontractor for unpaid wages and liquidated damages as provided in the clause set forth in subparagraph (b)(2) of 29 C.F.R. Part 5.5.

D.) Nonconstruction Grants: The Artist or subcontractor shall maintain payrolls and basic payroll records during the course of the work and shall preserve them for a period of three (3) years from the completion of the Agreement for all laborers and mechanics, including guards and watchmen, working on the Agreement. Such records shall contain the name and address of each such employee, social security number, correct classifications, hourly rates of wages paid, daily and weekly number of hours worked, deductions made, and actual wages paid. These records shall be made available by the Artist or subcontractor for inspection, copying, or transcription by authorized representatives of NJ TRANSIT, the FTA and the Department of Labor, and the Artist or subcontractor will permit such representatives to interview employees during working hours on the job.

E.) Subcontracts: The Artist or subcontractor shall insert in any subcontracts the clauses set forth in Paragraphs A through E of this Section and also a clause requiring the subcontractors to include these clauses in any lower tier subcontracts. The Artist shall be responsible for compliance by any subcontractor or lower tier subcontractor with the clauses set forth in Paragraphs A through E of this Section.

**8. LIMITATIONS ON LOBBYING:** The Artist shall comply with 31 U.S.C. 1352, entitled "Limitation on use of appropriated funds to influence certain Federal contracting and financial transactions".

A.) No appropriated funds may be expended by the recipient of a Federal contract, grant, loan or cooperative agreement to pay any person for influencing or attempting to influence an officer or employee of any agency, a Member of Congress, an officer or employee of Congress or an employee of a Member of Congress in connection with any of the following covered Federal actions: the awarding of any Federal contract, the making of any Federal grant, the making of any Federal loan, the entering into of any cooperative agreement, and the extension, continuation, renewal, amendment or modification of any Federal contract, grant, loan or cooperative agreement.

B.) Any Artist who requests or receives a Federally-assisted contract or subcontract in excess of \$100,000 from NJ TRANSIT shall file with NJ TRANSIT the certification attached to this Agreement and entitled "Certification for Contracts, Grants, Loans and Cooperative Agreements" which certifies that the Artist or subcontractor, as applicable, has not made, and will not make, any payment prohibited by paragraph A.) of this Article.

C.) Any Artist who has made or has agreed to make any payment using non appropriated funds (to include profits from any covered Federal action) which would be prohibited under paragraph A.) of this Article if paid for with appropriated funds, shall file with NJ TRANSIT a disclosure form entitled "Disclosure of Lobbying Activities", which is available from NJ TRANSIT.

D.) Any certification or disclosure form filed under paragraphs B.) and C.) of this Article shall be forwarded from tier to tier until received by NJ TRANSIT. Any certification or disclosure form shall be treated as a material representation of fact upon which all receiving tiers shall rely. All liability arising from an erroneous representation shall be borne solely by the tier filing that representation and shall not be shared by any tier to which the erroneous representation is forwarded.

E.) The prohibition on the use of appropriated funds does not apply in the case of a payment of reasonable compensation to an officer or employee of the Artist or subcontractor if the payment is for agency and legislative liaison activities not directly related to a covered Federal action.

F.) The prohibition on the use of appropriated funds does not apply in the case of any reasonable payment to an officer or employee of the Artist or to a person, other than an officer or employee of the Artist, if the payment is for professional or technical services rendered directly in the preparation, submission or negotiation of any Bid, proposal or application for a Federal contract, grant, loan or cooperative agreement.

**9. AUDIT AND INSPECTION OF RECORDS:** The Artist shall retain all Agreement records and permit the authorized representatives of the State of New Jersey, NJ TRANSIT, U.S. Department of Transportation (USDOT), the FTA and the Comptroller General of the United States and their duly authorized representatives, such as Project Management Oversight (PMO), Integrity Oversight Monitors (IOM) etc., to inspect and audit all financial data, operational data and other records of the Artist including but not limited to disclosure forms, payment requests, change orders, invoices, certified payrolls, manifests, etc. relating to its products, transactions or services provided under the

performance and that of its subcontractors and assignees, if any, under this Agreement from the effective date hereof through and until the expiration of five (5) years after completion of and final payment for the Project Services.

The Artist further agrees to include in all its subcontracts hereunder a provision to the effect that the subcontractor agrees that it will keep all Agreement records and that the State of New Jersey, NJ TRANSIT, the USDOT, the FTA and the Comptroller General of the United States and any of their duly authorized representatives shall, until the expiration of five (5) years after final payment under the subcontract, have access to and the right to examine pertinent books, documents, papers and records of such subcontractor involving transactions related to the subcontractor.

Documents of every nature prepared pursuant to this Agreement shall be available to and become the property of NJ TRANSIT, and basic notes and other pertinent data shall be made available to NJ TRANSIT upon request without restriction as to their future use.

At least until the expiration of five (5) years after the completion of, and final payment by, NJ TRANSIT for the Project Services, the Artist shall keep and maintain complete financial records showing actual time devoted and cost incurred in connection with services rendered under this Agreement, and it shall make same subject to inspection and audit by NJ TRANSIT, should NJ TRANSIT desire. Following passage of five (5) years from the date of completion of and final payment by NJ TRANSIT for the Project Services, the Artist may request from NJ TRANSIT permission to dispose of the various records. NJ TRANSIT may either order the records be destroyed or surrendered to NJ TRANSIT.

#### **10. BUY AMERICA**

Pursuant to 49 U.S.C. 5323(j) , and the regulation found at 49 C.F.R. Part 661, the Artist agrees that all iron, steel and manufactured products purchased or used as a result of this Agreement shall be of domestic manufacture or origin unless a waiver of these provisions is granted by the U.S. Secretary of Transportation.

There are four exceptions to this requirement:

- (a) That its application would be inconsistent with the public interest.
- (b) That such materials or products are not produced in the United States in sufficient and reasonably available quantities and of a satisfactory quality.
- (c) With respect to rolling stock only, but including train control, communications, traction power equipment, 40 percent may be non-domestic manufacture, but final assembly of such products must take place in the United States.
- (d) That inclusion of domestic material will increase the cost of the overall project contract by more than 25 percent.

**11. FLY AMERICA REQUIREMENTS:** The Consultant agrees to comply with 49 U.S.C. 40118 (the "Fly America" Act) in accordance with the General Services Administration's regulations at 41 C.F.R. Part 301-10, which provide that recipients and subrecipients of Federal funds and their

consultants are required to use U.S. Flag air carriers for U.S. Government-financed international air travel and transportation of their personal effects or property, to the extent such service is available, unless travel by foreign air carrier is a matter of necessity, as defined by the Fly America Act. The Consultant shall submit, if a foreign air carrier was used, an appropriate certification or memorandum adequately explaining why service by a U.S. flag air carrier was not available or why it was necessary to use a foreign air carrier and shall, in any event, provide a certificate of compliance with the Fly America requirements. The Consultant agrees to include the requirements of this section in all subcontracts that may involve international air transportation.

## **12. CLEAN WATER AND CLEAN AIR ACTS**

12.1 The Contractor agrees to comply with all applicable standards, orders, or regulations issued pursuant to the Federal Water Pollution Control Act, as amended, 33 U.S.C. § 1251 et seq.:

(a) With the notification of violating facilities provisions of Executive Order No. 11738; "Administration of the Clean Air Act and the Federal Water Pollution Control Act with Respect to Federal Contracts, Grants, or Loans", 42 U.S.C. § 7606. The Contractor agrees to report each violation to NJ TRANSIT and understands and agrees that NJ TRANSIT will, in turn, report each violation as required to assure notification to FTA and the appropriate EPA Regional Office.

(b) With the provisions of the Safe Drinking Water Act of 1974, as amended, 42 U.S.C. § 300h et seq.

12.2 The Contractor agrees to comply with all applicable, standards, orders or regulations issued pursuant to the Clean Air Act, as amended, 42 U.S.C. § 7401 et seq. The Contractor agrees to report each violation to NJ TRANSIT and understands and agrees that NJ TRANSIT will, in turn, report each violation as required to assure notification to FTA and the appropriate EPA Regional Office.

12.3 The Contractor agrees to include both the Clean Water and Clean Air requirements in each subcontract exceeding \$100,000. The \$100,000 limit includes indefinite quantities where the amount is expected to exceed \$100,000 in any year.

**13. ENERGY CONSERVATION:** The Consultant shall comply with mandatory standards and policies relating to energy efficiency contained in applicable State of New Jersey Energy Conservation Plans issued in compliance with the Energy Policy and Conservation Act (42 U.S.C. § 6321 et seq.).

## **14. INCORPORATION OF FEDERAL TRANSIT ADMINISTRATION (FTA) TERMS**

This Contract is funded in whole or in part by the United States Government and is subject to all Federal laws and regulations governing Federally-financed projects.

(a) Changes to Federal Requirements

The Contractor shall at all times comply with all applicable FTA regulations, policies, procedures and directives, including without limitation those listed directly or by reference in the Master Agreement between NJ TRANSIT and the FTA, as they may be amended or promulgated from time to time during the term of this Agreement. Contractor's failure to so comply shall constitute a material breach of this Agreement unless the FTA determines otherwise.

(b) Incorporation of FTA Terms

These General Provisions include, in part, certain standard terms and conditions required by USDOT, whether or not expressly set forth in this Agreement. All Contractual provisions required by USDOT, as set forth in FTA Circular 4220.1F, are hereby incorporated by reference. Anything to the contrary herein notwithstanding, all FTA mandated terms shall be deemed to control in the event of a conflict with other provisions contained in this Agreement. The Contractor shall not perform any act, fail to perform any act, or refuse to comply with any NJ TRANSIT requests which would cause NJ TRANSIT to be in violation of the FTA Master Agreement between NJ TRANSIT and the FTA.

## ATTACHMENT A

### FEES, MATERIALS AND PAYMENT SCHEDULE

1. The Contract Amount totals \$\_\_\_\_\_. This amount represents all costs, whether identified as a specific item or not, to provide the completed and installed artwork as described in the Artist's proposal, and as such, it includes any and all items and in terms as described in the NJSCA publication "Procedures for Artists in the Performance of Arts Inclusion Contracts" which are necessary to complete this project and shall be made part of this contract.
2. As payment for the Artwork, including all fees, supplies, design and transportation of same, Contractor will pay the Artist the total sum of (\$000,000.00) as follows:\*\*\*
  - a. \$00,000.00 upon consultation, acceptance of proposal, establishment of project timeline, acceptance of a date for submission of Design Development Plans and signing of contract.
  - b. \$00,000.00 upon acceptance of Design Development Plans (including installation plan) for Artwork.
  - c. \$00,000.00 upon receipt and approval of all signed and sealed shop drawings for the Artwork.
  - d. \$00,000.00 upon delivery of materials to the Artist, presentation of receipts or certifications of ownership for said materials, and start of construction.
  - e. \$00,000.00 upon 50% completion of the Artwork.
  - f. \$00,000.00 upon 100% installation of the Artwork.
  - g. \$00,000.00 upon 100% project completion including receipt of archival documentation, copyright application to NJSCA; acceptance of the Artwork by Contractor and NJ TRANSIT; submission of final invoice and close-out documents.

#### **Payment Notes**

Artist shall submit an invoice for each milestone to Contractor at the address identified under Article 34 of the contract.

Payment to the Artist shall be made not later than ten (10) calendar days after Terminal receives payment from NJ TRANSIT.

**NJ TRANSIT is exempt from sales tax; please provide sales tax exemption certificates to supplier.)**

**ATTACHMENT B**  
**PROGRESS SCHEDULE**

15 Calendar Days After Signing of the Agreement (Design and Development Plans) to NJ TRANSIT for Approval	The Artist submits complete Plans and Drawings
10 Calendar Days After Receipt of the Design and Development Plans	Design Development and Installation Plan approved by Contractor and NJ TRANSIT.
10 Calendar Days After Receipt of materials.	The Artist begins creation of Artwork.
To Be Determined	Meetings at the Artist's studio and/or fabricator to review and approve progress of Artwork. Pictural Documentation may be substituted
To Be Determined	Artwork ready for delivery and installation.
To Be Determined	Installation completed.
30 Calendar Days After Installation of the Artwork	Final approval by Contractor and completion of Agreement. The Artist submits all required project close-out documents.

**ATTACHMENT C**  
**SCOPE OF WORK AND BUDGET**

1. Purpose

The purpose of this Agreement is to provide the Artwork design, engineering design, construction documents, construction management, complete fabrication, complete transportation and complete installation for Artwork to be installed in the (NAME OF PROJECT).

2. Project Budget

The total contract for the Artwork is \$000,000 including all costs.

3. Schedule

The Artwork must be completed and ready for installation by MONTH, DAY, YEAR. Installation of the Artwork must be completed by MONTH, DAY, YEAR. All close-out submissions must be completed and submitted to NJ TRANSIT within thirty (30) calendar days after completion of installation.

4. Site Location

The Artwork will be installed in the (LOCATION) of the (NAME OF PROJECT). The exact location(s) for the Artwork(s) shall be proposed by the Artist in the Design Development Plans and approved by the project architect in writing.

5. Artwork Description

The Artist will design, fabricate, and deliver the following work of art:

- a. An Artwork which shall consist of (DETAILED DESCRIPTION OF ARTWORK (S)). The surface textures and color of the Artwork shall remain in accordance with the Artist's Design Development Plans as reviewed and accepted by Contractor and NJ TRANSIT.

The Artist shall execute and complete fabrication, transportation and installation of the Artwork upon consultation and coordination with Contractor. All dimensions for the Artwork shall be formally documented as a part of the Design Development Plans. Any structural plans shall be reviewed and approved by engineers who hold license in the State of New Jersey. The Artist will coordinate and produce pertinent plans, engineering and technical data and shall promptly submit such information in accordance with the project schedule as determined by Contractor.

The Artist shall be responsible for the structural integrity and proper installation of the Artwork. The installation plans shall be submitted and approved by NJ TRANSIT prior to installation of the artwork. Close contact shall be maintained with NJ TRANSIT project management staff to properly schedule installation activities.

- b. Project Control Specifications: The following are control specifications which address specific issues of the Artist's proposal are hereby incorporated into this Agreement.

1. There shall be no reduction in the scale of the elements which comprise the Artwork.



2. The Artist must provide clean connection devices for the mounting of the Artwork to ensure access for potential service needs/ease of maintenance/or removal of same.

3. The elements comprising the Artwork, must be absolutely secure in their mounting methods as called for in engineering calculations sealed by a New Jersey licensed engineer.

4. The Artist shall control the overall weight and structural integrity of each of the elements of the Artwork ensuring that they will not exceed live load design criteria as called for in engineering calculations sealed by a New Jersey licensed engineer and approved by Contractor's project architect/engineer (**NAME OF ENGINEER**).

5. The Artist shall use paints which ensure maximum color fading protection for the Artwork from exposure to UV rays.

6. The Artist shall provide all lighting equipment and fixtures (brackets and plugs) necessary for installation.

c. The Artist shall provide complete construction management services for the Artwork, which shall include, but not be limited to the following:

1. Schedule all work to be performed on the Artwork by both on and off site suppliers, fabricators or workers.

2. Provide all necessary engineering information and supervision for layout of the proper installation devices to insure that the eventual installation of the Artwork will properly interface with the structure.

d. The Artist shall provide the following upon completion of the Artwork.

1. Install, a plaque containing the title of the Artwork, Artist's name, credits and other information as per NJSCA guidelines. The plaque shall be publicly displayed at a size to be mutually agreed upon by NJ TRANSIT, and the Artist.

2. Delivery of complete archival documentation of the finished Artwork to the **NJSCA**:

a. All original designs, original drawings, and original presentation maquette.

b. 35mm slides, color and black and white photographs

c. A written physical description and statement of intent.

Such documentation shall be placed in the archives of the NJSCA and is to be supplied by the Artist not later than thirty (30) calendar days after the installation of the Artwork. Materials submitted must comply with the NJSCA documentation format for visual artwork. All such materials will remain joint property of NJ TRANSIT and the NJSCA.

## ATTACHMENT D

### CONTRACT DELIVERABLES

The following is a listing of contract deliverables that are required at the completion of each phase of this project. The detailed requirements of each deliverable item are specified in the NJSCA publication entitled "Procedures for Artists," a copy of which is attached hereto as part of this attachment.

#### Design Development Phase

<u>Ref.</u>	<u>Deliverable</u>
1.1.0	Art Design and Installation Plan
1.3.0	Time Schedule
1.4.0	Comprehensive Site Plan/Elevations, Details
1.7.0	Site Inspection

#### Construction/Project Phase

<u>Ref.</u>	<u>Deliverable</u>
2.1.0	Schedule and Progress Reports
2.2.0	Meetings
2.3.0	Correspondence
2.4.0	Pre-Construction/Project Meeting
2.5.0	Review and Approve Project Schedule
2.6.0	Coordinate with Project Management
2.7.0	Coordinate and Maintain Documentation
2.8.0	Certification of Insurance
2.9.0	Site Inspection/Field Observation Reports

#### Project Close-Out Phase

<u>Ref.</u>	<u>Deliverable</u>
3.1.0	Responsibilities
3.2.0	Commencement
3.3.0	<u>Project Close-Out Requirements</u>
3.3.1	Complete Photo
3.3.2	Project Plaque
3.3.3	Submission of Copyright Form VA
3.3.4	Maintenance Schedule
3.3.5	Publicity Agreement with NJSCA
3.3.6	Final Cost Analysis
3.3.7	Final Payment

**ATTACHMENT D**  
**ARTIST PROPOSAL FOR ARTWORK**

## Procurement Staff Checklist (for federal contracts)

Upon completion of the Required and/or Supplemental Forms packet(s), please be sure that the completed checklist and the forms listed below are included for each DBE subcontractor listed on the Form A and submitted to the Office of Business Development (OBD) for review.

**Note:** Failure to complete and submit the forms below will delay the OBD from issuing approval to move forward in the contract award process.

### Required Forms

- Form A - First Tier DBE Utilization
- Form A1 - Bidder/Proposer Solicitation and Contractor Information
- Form A2 - Non-DBE Sub Utilization
- Form B - Intent to Perform as a DBE Sub
- Form D - DBE Good Faith Effort Form
- Trucking Commitment Agreement (if applicable)

### Supplemental Forms (if applicable)

- Form AA - Second Tier DBE Utilization
- Form AA1 - Second Tier Bidder/Proposer Solicitation and Contractor Information
- Form AA2 - Second Tier Non-DBE Sub Utilization
- Form BB - Intent to Perform as a Second Tier DBE Sub
- Trucking Commitment Agreement (if applicable)

**NEW JERSEY TRANSIT CORPORATION  
DBE REQUIREMENTS FOR  
RACE-NEUTRAL GOAL PROGRAM  
FEDERAL PROCUREMENT ACTIVITIES**

**TABLE OF CONTENTS**

TITLE OF ARTICLE	PAGE
1.1 POLICY.....	2
1.2 ASSURANCE.....	3
1.3 DBE GOAL FOR THIS PROJECT.....	3
1.4 GUIDANCE TO BIDDER/PROPOSERS/PRIMES.....	3
1.5 TRANSIT VEHICLE MANUFACTURERS (TVM).....	4
1.6 RESPONSIBLE BID/PROPOSAL CRITERIA.....	4
2.1 GUIDANCE ON A GOOD FAITH .....	4-5
2.2 A GOOD FAITH EFFORT.....	5-6
2.3 REQUIRED FORMS.....	6-7
2.4 SUPPLEMENTAL REQUIRED FORMS (IF APPLICABLE).....	7
2.5 INSTRUCTIONS FOR COMPLETING REQUIRED FORMS.....	7-10
2.6 INSTRUCTIONS FOR COMPLETING SUPPLEMENTAL REQUIRED FORMS.....	10-11
3.1 GUIDANCE ON COUNTING DBE PARTICIPATION .....	11
3.2 COUNTING DBE PARTICIPATION.....	11-12
3.3 DBE PRIME CONTRACTOR GUIDANCE.....	12
3.4 DBE TRUCKING FIRM GUIDANCE.....	12
3.5 LEASING TRUCKS.....	12-13
3.6 COUNTING MATERIALS AND SUPPLIES.....	13
4.1 TERMINATION OF DBE(s).....	14
4.2 ADDITION OF DBE(s).....	14
4.3 REPLACEMENT OR REMOVAL OF DBE(s).....	14-15
4.4 WITHDRAWN DBE(s).....	15
4.5 DECERTIFIED DBE(s).....	15-16
5.1 AWARD OBLIGATIONS.....	16
5.2 POST AWARD DELIVERABLES .....	16-17
5.3 PROMPT PAYMENT OF INVOICES TO SUBCONTRACTORS.....	17-18
5.4 SUBCONTRACT PAYMENT DISPUTE RESOLUTION.....	18
5.5 PROMPT PAYMENT OF SUBCONTRACTOR RETAINAGE.....	18-19
5.6 REMEDIES AND PENALITES.....	19
5.7 LIQUIDATED DAMAGES.....	19-20
APPENDIX 1 (GLOSSARY).....	20-21

**NEW JERSEY TRANSIT CORPORATION  
DBE REQUIREMENTS FOR  
RACE-NEUTRAL GOAL PROGRAM  
FEDERAL PROCUREMENT ACTIVITIES**

This project is a component of our Race Neutral Goal Program; therefore, a Race-Neutral (RN) Disadvantaged Business Enterprise (DBE) goal has been established. NJ TRANSIT will meet a portion of its overall agency goal by using Race-Neutral means of facilitating DBE participation. NJ TRANSIT encourages Contractors to award subcontracts to DBEs.

NJ TRANSIT will track and report the extent of your Race-Neutral and Race-Conscious business assistance efforts. For reporting purposes, Race-Neutral/DBE participation includes, but is not necessarily limited to, the following:

- 1) DBE participation through a prime contract, a DBE obtains through customary competitive procurement procedures,
- 2) DBE participation through a subcontract on a prime contract that does not carry a DBE goal; DBE participation on a prime contract exceeding a contract goal; and
- 3) DBE participation through a subcontract from a prime contractor that did not consider a firm's DBE status in making the award.

Pursuant to Federal Regulations 49 CFR Part 26, the following pages will provide bidders/proposers with information about the New Jersey Transit Corporation (NJ TRANSIT) DBE Program requirements, which is administered by the Office of Business Diversity (OBD) Office. Clarification of the DBE specifications along with assistance in completing the forms can be obtained by calling (973) 491-7593. Prospective bidders will also have an opportunity to ask questions regarding the directives contained in the DBE specifications at the pre-bid/pre-proposal conference(s).

A list of certified DBE firms may be found in the NJ Unified Certification Program (NJUCP) Directory at [www.njucp.net](http://www.njucp.net). **Note: Use of this list does not relieve the Bidder/Proposer/Prime contractor/consultant of responsibility to seek DBE participation from other sources. The list is updated daily and must be checked periodically, as firms are certified and decertified daily.**

These DBE specifications are a part of the Contract and shall be binding upon the successful Bidder/Proposer and Prime in the pre and post-award stages of NJT professional services, construction, and goods and services contracts. These specifications shall be binding upon sub-recipients and imposed on their contractors.

### **1.1 POLICY**

As defined in the U.S. Department of Transportation (USDOT) Regulation 49 CFR Part 26, it is the policy of NJT that Disadvantaged Business Enterprises shall have the opportunity to compete for and participate in the performance of contracts financed in whole or in part with federal funds. Each subcontract a Prime signs with a

subcontractor/subconsultant must include the following assurance referenced in **article 1.2**.

## 1.2 ASSURANCE

- 1.2.1 The Prime contractor/consultant, or subcontractor/subconsultant shall not discriminate on the basis of race, color, national origin, or sex in the performance of this contract. The Prime contractor/consultant shall carry out applicable requirements of 49 CFR Part 26 in the award and administration of DOT-assisted contracts. Failure by the contractor/consultant to carry out these requirements is a material breach of this contract, which may result in the termination of this contract or such other remedy, as the recipient deems appropriate (49 CFR 26.13).
- 1.2.2 **This language is included to comply with relevant Federal law and to ensure that all persons who enter into any direct or indirect form of contractual agreement with NJT are aware of their responsibilities and the commitment of NJT to see that NJT's DBE Policy is carried out in all instances.**

## 1.3 DBE GOAL FOR THIS PROJECT

As an aid in meeting the commitment of its DBE Program, NJT is setting a *race neutral* goal of the gross sum bid/proposal to certified NJUCP DBE firms. A **race-neutral measure** is one that is used to assist all small businesses, including DBEs. For the purposes of this part, **race-neutral** includes gender-neutrality.

## 1.4 GUIDANCE TO BIDDER/PROPOSERS/PRIMES

- 1.4.1 Failure by a Bidder/Proposer/Prime to comply with any of the requirements contained herein shall result in breach of contract and it shall be subject to the appropriate penalties, remedies, or liquidated damage(s). **Refer to articles 5.6-5.7**
- 1.4.2 All required forms, including the supplemental section (**see articles 2.3-2.4**) must be submitted in accordance with the requirements. **Firms must be certified under the NJUCP at the time of contract award in order to obtain DBE credit toward the goal.**
- 1.4.3 Price alone is not an acceptable basis for rejecting a DBE subcontractor/subconsultant's bid.
- 1.4.4 The Bidder/Proposer/Prime shall, at a minimum, seek DBEs in the same geographic area in which it generally seeks subcontractors/subconsultants. However, the Bidder/Proposer/Prime may be required to expand its search under specific circumstances as determined by OBD. **Refer to article 2.0**
- 1.4.5 Agreements between a Bidder/Proposer/Prime and a DBE in which the DBE promises not to provide subcontracting quotations to other Bidder/Proposers are prohibited.
- 1.4.6 The desire of a Bidder/Proposer/Prime to self-perform the work of a contract with its own organization is not an acceptable basis to not meet the goal or demonstrate a good faith effort to do so.
- 1.4.7 The Bidder/Proposer/Prime is responsible for verifying that the DBE is certified under the appropriate NAICS code for the scope of work identified. DBE credit shall be given only for work performed in the NAICS code(s) under which the DBE is certified.
- 1.4.8 A DBE firm listed on the First-Tier DBE Utilization Form (Form A) shall constitute a binding representation to NJT, by the Bidder/Proposer/Prime, that the DBE firm is qualified, available, and certified under the appropriate DBE Requirements for Federal Procurement Activities

and required NAICS code to perform the scope of work identified. **Refer to article 2.5a**

## 1.5 TRANSIT VEHICLE MANUFACTURERS (TVM)

1.5.1 As a transit vehicle manufacturer, you must establish and submit for FTA's approval an annual overall DBE percentage goal. A TVM must certify that it submitted the annual DBE goal required by 49 CFR 26.49 and FTA has approved it or not disapproved it.

(a) As a condition of being authorized to bid or propose on FTA assisted transit vehicle procurements, the Bidder/Proposer must complete and submit the TVM Certification form with the bid/proposal certifying that it has complied with the requirements of 49 CFR 26.49.

1.5.2 NJT may, with FTA approval, establish project-specific goals for DBE participation in the procurement of transit vehicles in lieu of complying with the procedures of this section.

## 1.6 RESPONSIBLE BID/PROPOSAL CRITERIA

1.6.1 As a matter of responsibility, the two lowest Bidders or two highest ranked Proposers must submit the required forms, including the supplemental section (if applicable), with the bid/proposal or within seven (7) days after the bid opening or proposal due date. *NJT may grant a formal written request to extend this 7-day requirement at its sole discretion on a case-by-case basis.*

1.6.2 Failure to satisfactorily complete or submit all required forms when due may result in determination by NJT that the Bidder/Proposer is non-responsible and may cause rejection of the bid or proposal.

1.6.3 If the two lowest Bidders/highest ranked Proposers submit the DBE forms, but fail to meet the DBE goal, the OBD will consider the efforts made to determine if a Bidder/Proposer/Prime has in fact, demonstrated a good faith effort. **See article 2.0**

1.6.4 If it is determined that efforts were made to include DBE participation on the contract, however these efforts did not result in meeting the goal, NJT may request that additional efforts be made within 10 business days of the request. If at this time the Bidder/Proposer fails to demonstrate a good faith effort to achieve the goal, NJT shall consider awarding the contract to the next lowest bidder or highest ranked proposer who offers a reasonable price and meets the DBE goal or demonstrates a good faith effort and other bid requirements or requirements of 49 CFR Part 26.

## 2. GUIDANCE ON A GOOD FAITH EFFORT

2.1 To demonstrate a good faith effort to meet the DBE goal, a Bidder/Proposer/Prime shall provide written documentation in addition to Form D (article 2.3e), of the steps it has taken, prior to the bid opening/proposal due date, or during the life of the contract to obtain DBE participation. **The Bidder/Proposer/Prime can meet this requirement in either of two ways:**

(1) The Bidder/ Proposer/Prime can meet the goal.

(2) The Bidder/Proposer/Prime shall exhaust the available options referenced in **article 2.2** in making a continuous good faith effort to meet the assigned contract goal for the life of the contract.

(a) The efforts employed by the bidder should be those that one could reasonably expect a bidder to take if the



- bidder were actively and aggressively trying to obtain DBE participation sufficient to meet the contract goal.
- (b) In determining a good faith effort, the OBD will consider the **quality, quantity, and intensity** of the different kinds of efforts that the Bidder/Proposer/Prime has made. Mere *pro forma* efforts will not be considered as demonstration of good faith effort to meet the DBE contract requirements.
  - (c) The Bidder/Proposer/Prime shall use good business judgment and consider a number of factors in negotiating with subcontractors/subconsultants, including DBE subcontractors/ subconsultants, and should take a firm's price and capabilities as well as contract goals into consideration. **The fact that there may be some additional costs involved in finding and using DBEs is not in itself sufficient reason for a Bidder's/Proposer's failure to meet the contract DBE goal, as long as such costs are reasonable as determined by NJT. Primes are not, however, required to accept higher quotes from DBEs if the price difference is excessive or unreasonable.**
  - (d) The Bidder/Proposer/Prime's **ability or desire to perform the work of a contract with its own organization (self-performance) does not relieve the Bidder/Proposer/Prime of the responsibility to meet the goal or demonstrate a good faith effort.**
  - (e) The Bidder/Proposer/Prime shall not reject DBEs as being unqualified without sound reasons based on a thorough investigation of their capabilities. The Bidder/Proposer/Prime's standing within its industry, membership in specific groups, organizations, or associations and political or social affiliations (for example, union vs. non-union employee status) are not legitimate causes for the rejection or non-solicitation of bids in the Bidder/Proposer/Prime's efforts to meet the assigned project goal.
  - (f) The OBD will support the Bidder/Proposer/Prime in indentifying ways to meet the assigned contract goal.

## 2.2 A GOOD FAITH EFFORT

The following is a list of actions that NJT will consider as evidence of a Bidder/Proposer/Prime's good faith effort to obtain DBE participation. While exhausting the available options in this list may count as a good faith effort, this list is not intended to be a mandatory checklist, nor is this list intended to be exclusive or exhaustive of all the efforts a Bidder/Proposer/Prime might make to achieve the assigned DBE goal. NJT may require a Bidder/Proposer/Prime to take action above and beyond those listed below to meet the assigned DBE goal.

- (a) The Bidder/Proposer/Prime shall solicit through all reasonable and available means (e.g. attendance at pre-bid meetings, advertising and/or written notices) the interest of all certified DBEs who have the capacity to perform the work of the contract.
  - (1) The Bidder/Proposer/Prime must solicit this interest within sufficient time to allow the DBE to respond to the solicitation.
  - (2) The Bidder/Proposer/Prime must take appropriate steps to follow up on initial solicitations in order to determine with certainty if the DBE firms are interested.
- (b) The Bidder/Proposer/Prime shall select portions of the work to be performed by DBEs in order to increase the likelihood that the DBE goals will be achieved. This includes, where appropriate, breaking out contract work items into economically feasible units to facilitate DBE participation, even when the Prime might otherwise prefer to perform these work items with its own forces.
- (c) The Bidder/Proposer/Prime shall provide interested DBEs with adequate information about the plans, DBE Requirements for Federal Procurement Activities

specifications, and requirements of the contract in a timely manner to assist them in responding to a solicitation.

- (d) The Bidder/Proposer/Prime shall negotiate with a DBE(s) with the intent to enter into a contract. It is the Bidder/Proposer's responsibility to make a portion of the work available to DBE subcontractors/subconsultants and suppliers and to select those portions of the work or material needs consistent with the available DBE Primes and suppliers, so as to facilitate DBE participation.
  - (1) **Evidence of such negotiation includes:** the names, addresses, and telephone numbers of DBEs that were considered; a description of the information provided regarding the plans and specifications for the work selected for subcontracting; and evidence as to why additional agreements could not be reached for DBEs to perform the work.
- (e) The Bidder/Proposer/Prime shall make efforts to assist interested DBEs in obtaining bonding, lines of credit, or insurance as required by NJT or the Prime contractor.
- (f) The Bidder/Proposer/Prime shall make efforts to assist interested DBEs in obtaining necessary equipment, supplies, materials, or related assistance or services.
- (g) The Bidder/Proposer/Prime shall effectively use the services of available minority/women community organizations; minority/women Prime contractors groups; local, State and Federal minority/women business assistance offices; and other organizations as allowed on a case-by-case basis to provide assistance in the recruitment and placement of DBEs.

### 2.3 REQUIRED FORMS

- (a) **Form A - First Tier DBE Utilization:** Lists all First Tier DBE firms scheduled to participate on this contract.
- (b) **Form A1 - Bidder/Proposer Solicitation and Contractor Information:** Lists all DBE and Non-DBE sub contractor/subconsultants, including suppliers, solicited for, and participating on this contract.
- (c) **Form A2- Non-DBE Sub Utilization:** Lists all DBE and Non-DBE subcontractors/ subconsultants, including suppliers, participating on this contract.
- (d) **Form B - Intent to Perform as a DBE Sub:** Identifies the work the 1<sup>st</sup> Tier DBE intends to perform including scope of work, subcontract dollar value, etc.
- (e) **DBE Good Faith Effort Form (if applicable):** Identifies any DBE subcontractor invited to quote, but declined to do so for any reason.
- (f) **Trucking Commitment Agreement (if applicable):** Identifies all trucking firms (DBE and Non-DBE) participating on this contract, at any tier.
- (g) **NJ UCP DBE Certification & NAICS Code Verification:** Confirms the DBE status and NAICS code(s) of each First Tier DBE subcontractor/subconsultant.
- (h) **\*Form E - Contractor's Monthly DBE Payment Report & Payment Certification Voucher (Post-Award):** Records monthly payments issued to each DBE subcontractor/subconsultant/supplier and monthly payments issued by NJ TRANSIT to the Prime. Certifies that DBE subs have been paid for previous month's invoices.
- (i) **Form E2 – DBE's Monthly Payment Report (Post-Award):** Records monthly invoices submitted by the DBE,

payments owed to the DBE on past due invoices and payments received from the prime by each DBE subcontractor/subconsultant.

- (j) **Form E1- DBE Prime's Monthly Payment Report (For DBE Prime Only)**: Records monthly payments issued to each DBE Prime by NJ TRANSIT to.

*\*This form is due from the Prime in each month following the notice to proceed issued by NJ TRANSIT. Refer to article 5.2.4*

#### 2.4 SUPPLEMENTAL REQUIRED FORMS (IF APPLICABLE)

- (a) **Form AA – Second Tier DBE Utilization**: Lists all Second Tier DBE firms scheduled to participate on the DBE sub-Prime's contract.
- (b) **Form AA1 – Second Tier Bidder/Proposer Solicitation and Contractor Information**: Lists all Second Tier DBE firms participating on this contract as indicated on Form AA and Form AA2.
- (c) **Form AA2- Second Tier Non-DBE Sub Utilization**: Lists all DBE and Non-DBE firms including suppliers participating on the DBE sub-Prime's contract.
- (d) **Form BB - Intent to Perform as a Second Tier DBE Sub**: Identifies the work the 2<sup>nd</sup> Tier DBE intends to perform including scope of work, subcontract dollar value, etc.
- (e) **NJ UCP DBE Certification & NAICS Code Verification**: Confirms the DBE status and NAICS code(s) of each Second Tier DBE subcontractor/subconsultant.

#### 2.5 INSTRUCTIONS FOR COMPLETING REQUIRED FORMS (see glossary for definition of terms)

- (a) **Form A - First Tier DBE Utilization**:

Form A is a formal agreement between the Bidder/Proposer and the DBE(s). Replacement/removal of DBE subcontractors/subconsultants/supplier identified on Form A is prohibited after the bid or proposal is submitted to NJT. **Refer to article 4.3.** A DBE Bidder/Proposer, which lists itself on Form A, is committed to performing the work indicated with its own personnel.

DBEs performing as second tier sub(s) to a **non-DBE sub Prime** should be listed with the name of the non-DBE sub Prime's firm name in parenthesis next to the DBE sub's name. {*Ex: DBE Electric Co. (Prime Contractor, Inc.)*}

(1) A first Tier DBE is required to perform at least 51% of its subcontract value with its own forces.

Bidders/Proposers/Primes will not receive any credit for DBEs performing less than 51% and therefore must not be listed on this form.

(2) **For DBE suppliers**, identify all manufacturers, regular dealers, and brokers. If a DBE supplier is a **manufacturer**, indicate the full value of its subcontract. If a DBE supplier is a **regular dealer**, show its total contract value multiplied by 60% (Ex. \$100K x 60%= \$60K). If a DBE supplier is **neither a manufacturer nor a dealer**, indicate the fee/commission only, not the cost of materials or supplies.

See **article 3.0** for direction on determining credit toward the goal.

(3) A detailed scope of work must be provided; one-word descriptions are not acceptable. (Ex. Haul and dispose of approximately 192,000 tons of contaminated soil to a clean earth facility at \$34.00 a ton).

(b) **Form A1 - Bidder/Proposer/Prime Solicitation and Contractor Information:**

The Bidder/Proposer must complete and submit **page one** (1). The DBE and non-DBE subcontractors/subconsultants, including suppliers, solicited for, participating on, or expressed interest in this contract must complete **page two** (2).

(c) **Form A2- Non-DBE Sub Utilization:**

Bidders/Proposers are required to report and submit all dollars committed to non-DBE subcontractors/subconsultants/suppliers. The non-DBE portion of work is not counted toward the assigned DBE goal. **See article 3.0**

A detailed scope of work must be provided; one-word descriptions are not acceptable.

(Ex. Haul and dispose of approximately 192,000 tons of contaminated soil to a clean earth facility at \$34.00 a ton).

(d) **Form B - Intent to Perform as a First Tier DBE Sub:**

Each DBE subcontractor/subconsultant/supplier listed on Form A must complete and sign Form B. **Note: The Bidder/Proposer/Prime is prohibited from completing any portion of the form and from directing DBE(s) to sign a blank form.**

(1) The Bidder/Proposer/Prime must provide interested DBEs with a copy of appropriate plans, specifications, and requirements of the contract in a timely manner to allow the DBE to prepare an appropriate price quote and submit on time.

(2) First Tier DBEs must perform at least 51% of the total dollar value of its subcontract, with its own forces. The firm must indicate the percentage of the total portion of work to be subcontracted to DBE and non-DBE firms. The non-DBE percentage of work is not counted toward the assigned goal.

(3) The OBD encourages DBE-to-DBE subcontracting in order to preserve DBE participation credit. **See article 3.0**

(4) The DBE must provide a detailed scope of work; one-word descriptions are not acceptable. Descriptions should include: *type of services provided, total number of units, price per unit, total cost, etc.*

(e) **DBE Good Faith Effort: (If Applicable)**

Form D applies to any Bidder/Proposer/Prime who failed to meet the assigned DBE goal. This form will assist the Bidder/Proposer/Prime in demonstrating a good faith effort.

If the DBE(s) solicited declines to sign this form, the completed form should be submitted with the Bidder/Proposer's signature only and the OBD will verify the information provided with the firm. **Refer to articles 2.0-2.2** for guidance.

**(f) Trucking Commitment Agreement: (If Applicable)**

DBEs must provide information for all DBE and non-DBE trucking firms it will lease from or subcontract to. Subcontracting to a non-DBE trucker means that the non-DBE will perform a portion of the DBE firm's subcontract. **Refer to article 3.4**

The following documents must be attached for all trucks owned: copy of title(s)/finance agreement(s), registration card(s), insurance card(s), apportioned cab card(s) and/or hazardous material license(s) if applicable. A copy of the title or finance agreement is the only acceptable proof of ownership.

The following documents must be attached for all trucks leased: copy of lease agreement(s) established between both firms, title(s), registration card(s), insurance card(s), lease agreement(s), apportioned cab card(s) and/or hazardous material license(s) if applicable.

**(g) NJ UCP DBE Certification and NAICS Code Verification:**

All DBEs listed on Form A must be certified at the time of contract award. It is the Bidder/ Proposer's responsibility to ensure that DBEs are certified and that their NAICS code(s) match the scope of work to be performed on this contract. Credit will not be given for any work to be performed without the appropriate NAICS code. Status can be verified through [www.njucp.net](http://www.njucp.net) and [www.census.gov/eos/www/naics/](http://www.census.gov/eos/www/naics/).

**(h) Form E - Contractor's Monthly DBE Payment Report & Payment Certification Voucher:**

Beginning the month following the contract's notice to proceed, the Prime must report monthly payment activity for each DBE subcontractor/subconsultant/supplier; certifies each DBE sub has been paid any amounts due from previous or current progress payments paid to the Prime. **(article 5.2.4)**

All invoices 30 days past due from NJT must be listed in the appropriate field.

This report is due even if there is no payment activity. This form must be completed and submitted to the OBD **by the 7<sup>th</sup> of each month** to the attention of the OBD's Manager of Contract Compliance.

**(i) Form E1- DBE Prime's Monthly Payment Report (For DBE Prime Only)**

Beginning the subsequent month following the contract's execution date, the DBE Prime must report its monthly payments received by NJT. **Refer to article 5.2.5.**

All invoices 30 days past due from NJT must be listed in the appropriate field.

This report is due even if there is no payment activity. This form must be completed and submitted to the OBD **by the 7<sup>th</sup> of each month** to the attention of the OBD's Manager of Contract Compliance.

**(j) Form E2 – DBE's Monthly Payment Report:**

The Prime must provide a copy of the Form E2 to each DBE subcontractor/subconsultant/ supplier(s).

Beginning the subsequent month following the DBE's execution date, the DBE firm must report its monthly

payment activity.

This report is due even if there is no payment activity. **This form must be completed and submitted by the DBE only** to the OBD by the 7<sup>th</sup> of each month to the attention of the OBD's Manager of Contract Compliance.

All invoices 30 days past due must be listed in the appropriate field. Identify concerns or issues in the comments section to be addressed by the OBD. (Refer to article 5.2.6)

## 2.6 INSTRUCTIONS FOR COMPLETING SUPPLEMENTAL REQUIRED FORMS:

- (a) **Form AA – Second Tier DBE Utilization:** The Second Tier DBE must perform 100% of its subcontract with its own forces. A formal request to waive this requirement may be granted, solely at the discretion of the OBD; however, approval is required.

A detailed scope of work must be provided; one-word descriptions are not acceptable.

*(Ex. Haul and dispose of approximately 192,000 tons of contaminated soil to a clean earth facility at \$34.00 a ton).*

- (b) **Form AA1 – Second Tier Bidder/Proposer Solicitation and Contractor Information:**

The DBE sub-Prime must submit and complete **page one** (1). Second Tier DBE(s) solicited for and participating on this contract must complete **page two** (2).

- (c) **Form AA2- Second Tier Non-DBE Subcontractor Utilization:**

DBE sub-Primes are required to report and submit all dollars committed to non-DBEs. The non-DBE portion of work is not counted toward DBE participation credit. Refer to article 3.0

A detailed scope of work must be provided; one-word descriptions are not acceptable.

*(Ex. Haul and dispose of approximately 192,000 tons of contaminated soil to a clean earth facility at \$34.00 a ton).*

- (d) **Form BB - Intent to Perform as a Second Tier DBE Subcontractor:**

Each DBE firm listed on Form AA, must complete, and sign. **Only Second Tier DBE(s) must complete and sign this form.**

The Second Tier DBE must provide a detailed scope of work; one-word descriptions are not acceptable. Descriptions should include: type of services provided, total number of units, price per unit, total cost, etc

- (e) **NJ UCP DBE Certification & NAICS Code Verification:**

All DBEs listed on Form AA must be certified at the time of contract award. It is the Bidder/Proposer/Prime's responsibility to ensure that DBEs are certified and that their NAICS code(s) match the scope of work to be performed on this contract. Credit will not be given for any work to be performed without the appropriate NAICS code. Status can be verified through [www.njcup.net](http://www.njcup.net) and [www.census.gov/eos/www/naics/](http://www.census.gov/eos/www/naics/).

## 3.0 GUIDANCE ON COUNTING DBE PARTICIPATION

- 3.1 If a firm is not currently certified as a DBE in accordance with 49 CFR part 26 at the time of the execution of the DBE Requirements for Federal Procurement Activities

contract, the firm's participation will not count toward the DBE goal.

- 3.1.1 A DBE performing less than 51% of its subcontract will not count toward the assigned goal and should not be listed on any forms.
- 3.1.2 When a DBE subcontracts part of the work of its contract to another firm, the value of the subcontracted work may be counted toward DBE goals only if the DBE's subcontractor/subconsultant is a DBE.
  - (a) Work that a DBE subcontracts to a non-DBE firm does not count toward the DBE contract goal.
  - (b) When a DBE performs as a participant in a **joint venture with a Non-DBE**, count the portion of the total dollar value of the contract equal to the distinct, clearly defined portion of the work of the contract that the DBE performs with its own forces toward DBE goals.
  - (c) A DBE performs a *commercially useful function* when it is responsible for execution of the work of the contract and is carrying out its responsibilities by actually performing, managing and supervising the work involved.

**A DBE does not perform a *commercially useful function* if its role is limited to that of an extra participant in a transaction, contract, or project through which funds are passed in order to obtain the appearance of DBE participation.**

### 3.2 COUNTING DBE PARTICIPATION

- 3.2.1 When a DBE participates in a contract, only the value of the work actually performed by the DBE is counted toward DBE goals.
  - (a) The entire amount of that portion of a contract that is performed by the DBE's own forces is counted. This includes the cost of supplies and materials obtained by the DBE for the work of the contract, as well as supplies purchased or equipment leased by the DBE (*except supplies and equipment the DBE subcontractor/subconsultant purchases or leases from the Prime contractor or its affiliate*).
- 3.2.2 The entire amount of fees or commissions charged by a DBE firm for providing a bona fide service, such as professional, technical, consultant, or managerial services, or for providing bonds or insurance specifically required for the performance of a contract, is counted toward DBE goals, provided the fee is reasonable and not excessive as compared with fees customarily allowed for similar services by a DBE.

### 3.3 DBE PRIME CONTRACTOR GUIDANCE

- 3.3.1 If a **DBE Prime**, expenditures are counted toward DBE goals only if the DBE is performing a commercially useful function on that contract.
- 3.3.2 A DBE Prime must perform or be responsible at least 30% of the total cost of its contract with its own workforce.
- 3.3.3 **If a DBE Prime does not perform or exercise responsibility for at least 30% of the total cost of its contract with its own workforce** or subcontracts a greater portion of the work of a contract than would be expected on the basis of normal industry practice for the type of work involved, NJT will consider that it is not performing a commercially useful function and the DBE Prime shall be in breach of the contract and subject to the appropriate remedies and penalties. **Refer to Articles 5.6-5.7**

### 3.4 DBE TRUCKING FIRMS GUIDANCE

- 3.4.1 A DBE trucking firm is performing a commercially useful function if:

- (a) The DBE is responsible for the management and supervision of the entire trucking operation for which it is responsible on a particular contract, and there is not a contrived arrangement for the purpose of meeting DBE goals.
- (b) The DBE itself **owns and operates at least one** fully licensed, insured, and operational truck to be used on the contract.

3.4.2 The DBE receives credit for the total value of the transportation services it provides on the contract using trucks it owns, insures, and operates using drivers it employs.

### 3.5 LEASING TRUCKS

3.5.1 Leased trucks must display the name and identification number of the DBE.

3.5.2 The DBE may lease trucks from another DBE firm, including an owner-operator that is certified as a DBE. The DBE who leases trucks from another DBE receives credit for the total value of the transportation services the lessee DBE provides on the contract.

3.5.3 The DBE may also lease trucks from a **non-DBE firm**, including an owner-operator.

(a) **The DBE who leases trucks from a non-DBE is entitled to credit only for the fee or commission it receives as a result of the lease arrangement.**

3.5.4 For the purposes of this section (Leasing), a lease must indicate that the DBE has exclusive use of and control over the truck.

(a) This does not preclude the leased truck from working for others during the term of the lease with the consent of the DBE, so long as the lease gives the DBE absolute priority for use of the leased truck.

### 3.6 COUNTING MATERIALS AND SUPPLIES

3.6.1 Expenditures with DBEs for materials or supplies are counted toward DBE goals as provided in the following:

- (a) If the materials or supplies are obtained from a **DBE manufacturer**, 100% of the cost of the materials or supplies are counted toward DBE goals.
  - (1) For purposes of this paragraph 3.6.1(a), a manufacturer is a firm that operates or maintains a factory or establishment that produces, on the premises, the material, supplies, articles, or equipment required under the contract and of the general character described by the specifications.
- (b) If the materials or supplies are purchased from a **DBE regular dealer**, sixty percent (60%) of the cost of the materials or supplies is counted toward DBE goals.
  - (1) For purposes of this paragraph 3.6.1(b), a regular dealer is a firm that owns, operates, maintains a store, warehouse, or other establishment in which the materials, supplies, articles or equipment of the general character described by the specifications and required under the contract are bought, kept in stock, and regularly sold or leased to the public in the usual course of business.
  - (2) The firm must be an established, regular business that engages, as its principal business and under its own name, in the purchase and sale or lease of the products in question.
  - (3) A person may be a regular dealer in such bulk items as petroleum products, steel, cement, gravel, stone,



or asphalt without owning, operating, or maintaining a place of business as provided above if the person both owns and operates distribution equipment for the products. Any supplementing of regular dealers' own distribution equipment shall be by a long-term lease agreement and not on an ad hoc or contract-by-contract basis.

- (4) Packagers, brokers, manufacturers' representatives, or other persons who arrange or expedite transactions are not regular dealers within the meaning of this paragraph 3.6.1(b).
- (c) With respect to materials or supplies purchased from a DBE, **which is neither a manufacturer nor a regular dealer**, only the entire amount of fees or commissions charged for assistance in the procurement of the materials and supplies, or fees or transportation charges for the delivery of materials or supplies required on a job site, is counted toward DBE goals, provided the fees are determined to be reasonable and not excessive as compared with fees customarily allowed for similar service. **However, any portion of the cost of the materials and supplies themselves do not count toward DBE goals.**

#### 4.0 TERMINATION OF DBE(s)

- 4.1 The Bidder/Proposer/Prime may not terminate for convenience, or any other reason, and then perform the work of the terminated subcontractor/subconsultant with its own forces or those of an affiliate without NJT's prior written consent. **Refer to Article 4.3.**

***Submission of all REQUIRED FORMS is mandatory for the following Articles 4.2 through 4.5***

#### 4.2 ADDITION OF DBE(s)

- 4.2.1 Should the Bidder/Proposer/Prime wish to add a DBE not listed on Form A, a written request for the addition of a DBE(s) must be submitted by the Bidder/Proposer/Prime.
- 4.2.2 The Bidder/Proposer/Prime must receive written approval of the OBD **prior to** the addition of the DBE subcontractor/subconsultant in order for the addition to be credited toward the goal.

#### 4.3 REPLACEMENT OR REMOVAL OF DBE(s)

- 4.3.1 When a Prime is considering replacing or removing a DBE due to performance issues, the OBD must be contacted as soon as possible.
- 4.3.2 Request for DBE replacement or removal may be made under the following conditions:
- 1) The DBE materially fails to successfully perform the contract tasks.
  - 2) Under unusual situations referenced in article 4.3.8.
- 4.3.3 A written request for replacement or removal of a DBE(s) listed on Form A, must be submitted by the Bidder/Proposer/Prime to the OBD with complete justification for the request. The process to follow such requests is as follows:
- (a) Written communications (over a period) from the Prime and/or NJT's PM/CM team to the DBE, notifying the DBE of its poor performance must be provided to the OBD.
  - (b) **The OBD will arrange a meeting with the DBE, the Prime, and a representative from Procurement and project management to discuss the specifics of the performance issue.**

- (c) The DBE must provide a written plan identifying the efforts it will make to correct the deficiencies.
- (d) The Prime must provide the DBE with a minimum of 30 calendar days from acceptance of its plan to improve its performance. Throughout the 30-day window, the Prime and/or NJT PM/CM team must provide written communication to the DBE of any additional/continued performance issues, with a copy to the OBD.

4.3.4 The Bidder/Proposer/Prime must receive written approval of the OBD **prior to** replacement or removal of the DBE subcontractor/subconsultant can be made, regardless of the reason for the replacement or removal.

4.3.5 If the OBD issues written approval for the removal of a DBE(s), NJT will require a Bidder/Proposer/Prime to continue to demonstrate a good faith effort to replace the removed DBE to the extent needed to meet the contract goal established by NJT for the procurement.

**These good faith efforts shall be directed at finding another DBE to perform at least the same amount of work under the contract as the removed DBE.**

4.3.6 Failure to obtain approval from the OBD **prior to** replacing or removing a DBE shall result in the Bidder/Proposer/Prime being found in breach of the contract and subject to the appropriate remedies, audits and penalties. **Articles 5.6-5.7**

4.3.7 If NJT finds that the Bidder/Proposer/Prime upon submission of its bid/proposal committed itself to the goal in good faith, the Bidder/Proposer/Prime may, in "unusual situations", be permitted to substitute a DBE subcontractor(s)/subconsultant(s).

4.3.8 The term "unusual situations", includes, but is not limited to, the following circumstances:

- (a) Failure to qualify as a DBE, or maintain DBE certification status.
- (b) Death or physical disability of a key individual.
- (c) Dissolution, if a corporation or partnership.
- (d) Bankruptcy of the subcontractor/subconsultant, subject to applicable bankruptcy law, and only in instances where the bankruptcy affects the subcontractor/subconsultant's ability to perform.
- (e) Inability to obtain, or loss of, a license necessary for the performance of the particular category of work.
- (f) Failure or inability to comply with a requirement of law applicable to Primes or, subcontractors/subconsultants.

#### **4.4 WITHDRAWN DBE(s)**

4.4.1 When a DBE is unable to complete a subcontract (withdraws), for any reason, NJT will require a Bidder/Proposer/Prime to make a good faith effort to replace a withdrawn DBE at least to the extent needed to ensure that the Prime contractor is able to meet the contract goal established by NJT for the procurement. **These good faith efforts shall be directed at finding another DBE to perform at least the same amount of work under the contract as the removed DBE.**

4.4.2 The Bidder/Proposer/Prime is required to make a good faith effort to seek other DBE subcontractors/subconsultants in substitution of the original DBE. The good faith efforts described in **article 2** are required in finding another DBE to perform at least the same amount of work under the contract as the DBE that was terminated, to the extent needed to meet the contract goal established for the procurement.

#### **4.5 DECERTIFIED DBE(S)**

- 4.5.1 If the Prime has reason to doubt that a proposed DBE is still eligible due to change in ownership, management, or size, the Prime shall, within 10 days of learning this information, notify NJT of that fact in writing.
- 4.5.2 If the subcontract has not been executed before the DBE's ineligibility occurs, the Prime will not receive credit toward the contract goal for the ineligible DBE. The Prime may continue to use the ineligible DBE, however, DBE participation credit will not be granted.
- (a) To the extent necessary to meet the assigned contract goal, the Prime will make a good faith effort to replace the ineligible DBE within 10 days after notification by the OBD. The OBD will support the Prime in its efforts to replace with an eligible DBE firm in order to meet the contract goal.
- 4.5.3 If the contract has been executed before the firm has been notified of its ineligibility, the Prime may continue to use the firm on the contract and receive credit toward its DBE goal for the duration of that particular phase of or option in the contract. This may not apply to future phases or options, which will be handled on a case-by-case basis at the sole discretion of the OBD.
- 4.5.4 **Exception:** If the DBEs ineligibility is caused solely by its having exceeded the size standard during the performance of the contract the Prime may continue to count its participation on that contract only toward the contract goals. This may not apply to future phases or options and will be subject to determination by the OBD.

## 5.0 AWARD OBLIGATIONS

- 5.1 The Prime must designate a **DBE Liaison Officer**. The liaison officer will be responsible to NJT regarding DBE subcontract matters.
- 5.1.1 If at any point during the contract's life, the Prime's DBE participation falls below the assigned goal, the Prime must identify additional work or new work items for which it will subcontract to DBEs to the extent necessary to meet the assigned goal. Any new scope of work issued to the Prime shall still be subject to the assigned goal.
- 5.1.2 The OBD will support the Prime in identifying current/future opportunities in the contract to meet the assigned contract goal.
- 5.1.3 Should the Prime seek a change that addresses the DBE's performance, or affects the work scope and/or compensation, the OBD must be notified, prior to implementation, for its review and approval of the changes as soon as possible. No change will be allowed without prior review and approval by the OBD. Failure to notify the office and obtain approval prior to a change shall result in breach of the contract and may be subject to the appropriate remedies, audits, and penalties.
- 5.1.4 Whenever NJT issues project change orders the goal may still apply; the OBD will determine if increased DBE participation will be required.
- 5.1.5 To ensure that all obligations under subcontracts awarded to DBEs are met NJT shall review the Prime's DBE involvement efforts during the performance of the contract.

## 5.2 POST AWARD DELIVERABLES

- 5.2.1 After the execution of a contract with NJT, **signed copies** of subcontractor/subconsultant agreements between the Prime and DBE subcontractors must be submitted to the OBD no later than 10 business days after the Prime's contract execution date. The agreement between the Prime and DBE subcontractor shall remain firm for the duration of the contract.

- 5.2.2 The Prime shall provide a list of the anticipated job start date for all DBE subcontractors/subconsultants **no later than two days** after the initial pre-construction meeting.
- 5.2.3 **Certification of DBE(s) Payments** – submit monthly with the Form E to the Manager of the OBD and with its monthly invoice submittal to NJT project manager of this project. **Refer to article 5.3.2**
- (a) The Prime will certify, prior to the issuance of each progress payment by NJT, that all DBE subs have been paid any amounts due on past due invoices from previous or current progress payments.
- 5.2.4 **Form E (Contractor's Monthly DBE Payment Report & DBE Payment Certification Voucher)** - submit monthly to the Manager of the OBD. **Refer to articles 2.5h and 5.3.2.**

**Failure to submit this report on a monthly basis may result in breach of the contract and be subject to the appropriate remedies, penalties or liquidated damages as indicated in articles 5.6-5.7.**

- 5.2.5 **Form E1 (DBE Prime's Monthly Payment Report) (For DBE Prime Only)** - submit monthly to the Manager of the OBD.
- 5.2.6 **Form E2 (DBE's Monthly Payment Report)** – Refer to article 2.5j
- (a) Forms E/E1 and E2 will be reviewed monthly to determine compliance with the assigned DBE goal, the subcontractor prompt payment regulation, and the DBE Program.
- (b) Attainment of goals will be monitored and based upon actual payments received by the DBE.
- Failure to submit Form E/E1 may result in suspension of payments or such other remedies as provided in **article 5.6**. *If at any time, NJT has reason to believe that any person or firm has willfully and knowingly provided incorrect information or made false statements, it shall refer the matter to the USDOT for inquiry.*

### **5.3 PROMPT PAYMENT OF INVOICES TO SUBCONTRACTORS**

- 5.3.1 The Prime must pay each subcontractor under this contract for satisfactory performance of its work **no later than ten (10) days** from the receipt of each payment the Prime receives from NJT for the subcontractor's work. Failure to comply with this requirement shall result in breach of the contract and shall be subject to the appropriate remedies as determined by OBD.
- 5.3.2 In accordance with 49 CFR 26.29, the Prime shall certify, prior to the issuance of a progress payment by NJT that all subcontractors have been paid any amounts due on past due invoices (greater than 30 days) from previous or current progress payments. **The Prime must submit the Certification of DBE(s) Payments with its monthly invoice submittals to NJT project manager, and with its Form E to the OBD.**
- 5.3.3 The Prime will not be reimbursed for work performed by subcontractors/subconsultants unless and until the Prime ensures that the subs are promptly paid for the work performed. Alternatively, the Prime shall certify that a valid basis exists under the terms of the subcontractor's/subconsultant's or supplier's contract to withhold payment from the subcontractor/subconsultant and therefore payment is withheld.
- 5.3.4 If the Prime withholds payment from the subcontractor/subconsultant, the Prime shall provide to the subcontractor/subconsultant or supplier written notice thereof. The notice shall detail the reason for withholding payment and state the amount of the payment withheld. If a performance/payment bond has been provided under this contract, the Prime shall send a copy of the notice to the surety providing the bond for the Prime. A

copy of the notice shall also be submitted to NJT with the certification that payments are being withheld.

5.3.5 If withholding payment is due to the Prime's failure to promptly pay the DBE in accordance with the prompt payment of invoices and/or retainage clauses, the OBD may request proof of payment to DBE(s) for delinquent invoices and/or retainage in order to issue release of payment to Prime.

5.3.6 Failure to comply with the above shall result in breach of the contract and may be subject to the appropriate penalties. **See article 5.6**

#### **5.4 SUBCONTRACTOR PAYMENT DISPUTE RESOLUTION**

5.4.1 The Prime is required to notify the OBD of its intention to withhold payment from a DBE as soon as possible and in advance of taking action. Should the Prime provide notice and proceed to withhold payment from any subcontractor/subconsultant or supplier due to a performance issue or unapproved work performed, an OBD representative shall make an effort to resolve the dispute.

- (a) OBD's efforts shall be limited to meeting with the Prime and the subcontractor/ subconsultant, and reviewing the relevant facts with both parties.
- (b) OBD will not act as a decider of fact nor will OBD direct a settlement to the dispute.
- (c) Any OBD effort is solely intended to assist the parties in understanding their respective positions and to encourage a reasonable resolution of the dispute. The Prime is required to send written notification of the above to the OBD immediately.

5.4.2 Should payments be withheld that are not related to the previous items mentioned, and/or a determination can be made that the withholding of payments violates the prompt payment clause, NJT may execute the appropriate remedies in accordance with article 5.6.

#### **5.5 PROMPT PAYMENT OF SUBCONTRACTOR RETAINAGE (FOR CONSTRUCTION CONTRACTS ONLY)**

5.5.1 **The Prime must include a contract clause in the subcontractor agreement obligating the Prime to pay all retainage owed to the subcontractor/subconsultant for satisfactory completion of the accepted scope of work no later than 15 days after the DBE subcontractor's/subconsultant's work is satisfactorily completed.**

5.5.2 Only subcontractors/subconsultants whose work has been 100% completed, including all punch list work or remaining work, and who have supplied closeout documents shall be eligible for release of retainage. *Any delay or postponement of payment from the above referenced time frame may occur only for good cause following written approval of NJT.*

5.5.3 NJT may agree to release an equivalent amount of Prime retainage provided that:

- (a) There is no offsetting claims from NJT (including, but not limited to, liquidated damages), other subcontractors/subconsultants, material men, or workers;
- (b) None of the other reasons to withhold payments specified under the Prime contract exists.

5.5.4 Prior to release of the Prime's retainage, the Prime shall provide to NJT executed copies of the following subcontractor closeout documents, (shown in Appendix A of the contract) as appropriate:

- (a) Consent of Surety to Final Payment to the Subcontractor

- (b) Certificate of Amounts Due and Owing to Subcontractor Employees
- (c) Subcontractor Release of Claims
- (d) Subcontractor Release of Liens and a Certificate of Final Acceptance of Subcontractor Work

5.5.5 Notwithstanding NJT's release or partial release of retainage, nothing in this clause shall be deemed to constitute NJT's partial or final acceptance of the work, or any portion thereof, unless either a Certificate of Partial Acceptance or a Certificate of Final Acceptance has been executed by NJT, in the form(s).

## **5.6 REMEDIES AND PENALTIES**

5.6.1 Where a Prime is found to be in breach of the requirements of the DBE Program during the performance of the contract, and does not promptly take corrective action, the following sanctions may be instituted (singularly, in any combination, and in addition to any other contractual remedies or otherwise provided by law):

- (a) The Prime may be ordered to stop work without penalty to NJT.
- (b) The contract may be terminated for breach.
- (c) Suspension or debarment proceedings may be commenced in accordance with New Jersey law.
- (d) The relevant performance bond may be enforced.
- (e) NJT may withhold payment of specific invoices.

## **5.7 LIQUIDATED DAMAGES**

5.7.1 Liquidated damages (LD) may be assessed when the Prime fails to meet the established DBE goal on the contract.

5.7.2 If the DBE goal is not met, and the Prime has not demonstrated a good faith effort to do so, NJT may elect to subtract from the Prime's payment, as liquidated damages and not a penalty, the following:

The amount equal to the difference (in dollars) between the total contract value multiplied by the assigned DBE goal percentage, (originally established or as subsequently modified) and the actual DBE participation percentage (total dollars paid to DBEs divided by total dollars paid to the Prime).

5.7.3 This may be withheld from a series of payments or from the Prime's final payment, depending on the size of the liquidated damage.

5.7.4 If the Prime's final payment is not sufficient to satisfy the LD in full, the balance shall be due and owing from the Prime and subject to repayment terms as determined by NJT. NJT shall waive liquidated damages where good cause is shown for the deficiency in DBE participation upon determination by the OBD.

## APPENDIX I

### GLOSSARY

**A Good Faith Effort**-the efforts employed by the bidder, which should be those that one could reasonably expect a bidder to take if the bidder were actively and aggressively trying to obtain DBE participation sufficient to meet the contract goal.

**Certification** - means the process by which a business is determined to be a bona fide DBE. Any business applying for DBE certification must complete the appropriate NJ Unified Certification Program Application. Certification Applications are available at the OBD.

**Disadvantaged Business Enterprise or DBE** - means a small business concern:

Which is at least 51 percent owned by one or more socially and economically disadvantaged individuals, or in the case of any publicly owned business, at least 51 percent of the stock of which is owned by one or more socially and economically disadvantaged individuals; and where one or more of the socially and economically disadvantaged owners controls management and daily business operations. A DBE shall not include a small business concern where that concern or a group of concerns controlled by the same socially and economically disadvantaged individual or individuals has annual average gross receipts in excess of **\$22,410,000** over the previous three fiscal years or is not otherwise eligible as a small business as defined by the Small Business Administration in 13 CFR Part 121.

**DBE Goal** - means numerically expressed objectives for DBE participation on federal contracts Prime contractors are required to make a good faith effort to achieve to the extent necessary to meet the assigned DBE goal.

**DBE Sub-Prime** - means any 1<sup>st</sup> Tier DBE subcontractor/subconsultant listed on the Form A that will subcontract any portion of its subcontract/scope of work to a DBE(s) and/or non-DBE(s) firm(s).

**DBE Ineligibility** – means a firm's DBE status changes or ceases due to change in ownership, management, or size, etc.

**DBE Prime** – means the successful Bidder is a DBE firm and has a direct contract with NJT.

**DBE Trucking Firm** – owns and operates at least one fully licensed, insured, and operational truck used on the contract. Is responsible for the management and supervision of the entire trucking operation for which it is responsible on a particular contract.

**First Tier DBE** - refers to any DBE listed on the Bidder/Proposer/Prime's Form A and having a direct contract with the Prime.

**Joint Venture**–means an association of a DBE firm and one or more other firms to carry out a single, for-profit business enterprise, for which parties combine their property, capital, efforts, skills and knowledge, and in which the DBE is responsible for a distinct, clearly defined portion of the work of the contract and whose share in the capital contribution, control, management, risks, and profits of the joint venture are commensurate with its ownership interest.

**Prime** - means any contractor or consultant, including a DBE contractor/consultant, who enters into a direct contractual relationship with NJT.

**Race-conscious Measure or Program** - is one that is focused specifically on assisting only DBEs, including women-owned DBEs.

**Race-neutral Measure or Program**- is one that is focused specifically on assisting all small businesses equally, including DBEs. Such activities include bonding, insurance, and technical assistance. For the purposes of this part, race-neutral includes gender-neutrality.

**Reasonable Bid Price** - means a price that shall be considered reasonable if the Bidder/Proposer/Prime would have been awarded the contract had the firm submitted the only bid.

**Regular Dealer** - means a firm that owns, operates, or maintains an establishment in which the materials or supplies required for the performance of a contract are bought, kept in stock and regularly sold to the public in the usual course of business.

The firm must engage in, as its principal business, and in its own name, the purchase and sale of products in question. Bulk items such as steel, cement and petroleum products need not be stocked, if the dealer owns or operates distribution equipment.

**Note: Brokers and packagers are not regarded as regular dealers.**

**Second Tier DBE** - refers to any DBE listed on the DBE Sub-Prime's Form AA.

**Subcontractor/ Subconsultant** - means any contractor/consultant, including suppliers, who enters into a contract issued by a Prime contractor.

**Transit Vehicle Manufacturer (TVM)** - is a manufacturer of vehicles used by NJT for the primary program purpose of public mass transportation (e.g., buses, railcars, vans). The term does not apply to firms, which rehabilitate old vehicles, or to manufacturers of locomotives or ferryboats. The term refers to distributors of or dealers in transit vehicles with respect to the requirements of 49 CFR Section 26.49.

**U.S. DOT** – means the U.S. Department of Transportation, including the Office of the Secretary, the Federal Highway Administration (FHWA), the Federal Transit Administration (FTA), and the Federal Railroad Administration (FRA).

**Withdrawn DBE** – a DBE withdraws, or drops out of its contract, or fails to complete its work on the contract for any reason.



## **Bidders Checklist (for federal contracts)**

Upon completion of the Required and/or Supplemental Forms packet(s), please be sure that the completed checklist and the forms listed below are included for each DBE subcontractor listed on the Form A and submitted to the Office of Business Development (OBD) for review.

**Note:** Failure to complete and submit the forms below will delay the OBD from issuing approval to move forward in the contract award process.

### **Required Forms**

- Form A - First Tier DBE Utilization
- Form A1 - Bidder/Proposer Solicitation and Contractor Information
- Form A2 - Non-DBE Sub Utilization
- Form B - Intent to Perform as a DBE Sub
- Form D - DBE Good Faith Effort Form
- Trucking Commitment Agreement (if applicable)

### **Supplemental Forms (if applicable)**

- Form AA - Second Tier DBE Utilization
- Form AA1 - Second Tier Bidder/Proposer Solicitation and Contractor Information
- Form AA2 - Second Tier Non-DBE Sub Utilization
- Form BB - Intent to Perform as a Second Tier DBE Sub
- Trucking Commitment Agreement (if applicable)

# REQUIRED FORMS

ENCLOSED FOR COMPLETION (MANDATORY):

- Form A; A1; A2; B; D & Trucking Commitment Schedule

TO BE OBTAINED AND SUBMITTED (MANDATORY):

- Copy of a valid NJUCP DBE Certificate (Provided by 1<sup>st</sup> Tier DBEs.)

Consult DBE Program Requirements for further guidance.

**First Tier DBE UTILIZATION - FORM A**

Project Name: \_\_\_\_\_

NJT Contract No: \_\_\_\_\_

Assigned DBE Goal %: \_\_\_\_\_ NJT Procurement Specialist: \_\_\_\_\_

Contract Value (\$): \_\_\_\_\_

**First Tier DBE must perform at least 51% of its subcontract value if subcontracting to a Second -Tier DBE or Non-DBE. Do not count Non-DBE portion toward the goal.**

Name, Address and Telephone # of DBE Subcontractor/Subconsultant	Provide <u>Detailed</u> Scope of Work to be Performed (Identify all suppliers)	Dollar Value of Subcontract/Sub-consultant Work (\$) Awarded	Percentage of Subcontract Work (%)
			%
			%
			%
			%
			%
For DBE suppliers, show original subcontract value multiplied by 60% (\$2,000*60%=\$1200). For DBE portion of work, subtract Non-DBE portion of work from original subcontract value.	<b>TOTALS</b>	\$	%

The undersigned will enter into a formal agreement with the DBE(s) listed in this schedule conditioned upon execution of a contract with NJ TRANSIT for the above referenced project. The undersigned understands that removal/replacement of the DBE(s) listed is NOT PERMISSIBLE for any reason (pre or post-award), without submitting a written request to the Office of Business Development and receiving WRITTEN APPROVAL from the Office of Business Development. Failure to obtain written approval shall result in the breach of contract and subject to corrective action to be determined by NJ TRANSIT.

Company Name: \_\_\_\_\_

Authorized Signature: \_\_\_\_\_

Company Address: \_\_\_\_\_

Print Name: \_\_\_\_\_

\_\_\_\_\_

Title: \_\_\_\_\_

Federal Tax ID #: \_\_\_\_\_

Prime Contractor's DBE Liaison Officer: \_\_\_\_\_

Company Tel #: \_\_\_\_\_

Date Signed: \_\_\_\_\_

**BIDDER SOLICITATION & CONTRACTOR INFORMATION - FORM A1**

NJT Contract No: \_\_\_\_\_

Project Title: \_\_\_\_\_

Prime Contractor: \_\_\_\_\_

Telephone #: \_\_\_\_\_

Date: \_\_\_\_\_

*Complete the information below for Bidder/Proposer/Prime(s) working on the project. Use Page 2 for all subcontractors/subconsultants participating on or solicited for this project.*

	Bidder/Proposer/Prime	Bidder/Proposer/Prime	Bidder/Proposer/Prime
Company's Full Name			
Address			
City			
Zip			
County			
Phone			
Fax			
E-mail			
Owner			
Date Established			
Date Certified			
Ethnicity			
Gender			
Certification Status: DBE or Non-DBE			
Federal Tax ID # / SSN #			
Annual Gross Receipts: A - Less than \$500K B - \$500K to \$1M C - \$1M to \$2M D - \$2M to \$5M E - \$5M and over <b>indicate the letter that applies</b>			
Primary NAICS Code:			

**BIDDER SOLICITATION & CONTRACTOR INFORMATION - FORM A1**

NJT Contract No: \_\_\_\_\_  
 Prime Contractor: \_\_\_\_\_  
 Date: \_\_\_\_\_

Project Title: \_\_\_\_\_  
 Telephone #: \_\_\_\_\_

*Complete the information below for "all" subcontractors/subconsultants solicited for or participating on this project.*

Subcontractor/Subconsultant	Subcontractor/Subconsultant	Subcontractor/Subconsultant	Subcontractor/Subconsultant
Company's Full Name			
Address			
City			
Zip			
County			
Phone			
Fax			
E-mail			
Owner			
Date Established			
Date Certified			
Ethnicity			
Gender			
Certification Status: <b>DBE or Non-DBE</b>			
Federal Tax ID # / SSN #			
Annual Gross Receipts: A - Less than \$500K B - \$500K to \$1M C - \$1M to \$2M D - \$2M to \$5M E - \$5M and over <b>indicate the letter that applies</b>			
Primary NAICS Code:			

**NON-DBE SUBCONTRACTOR UTILIZATION - FORM A2**

*Directions: To be completed by any Bidder/Proposer/Prime for "all" subs including suppliers participating on this contract.*

NJ Transit Contract No: \_\_\_\_\_

Date: \_\_\_\_\_

Prime Contract Value: \_\_\_\_\_

Bidder/Proposer Prime Name: \_\_\_\_\_

Project Title: \_\_\_\_\_

Name, Address and Telephone # of all Subcontractor/Subconsultants	FEIN #	Provide Detailed Scope of Work to be Performed	Dollar Amount of Subcontractor/Sub-consultant Work (\$) Awarded	Percentage of Subcontract or Work (%)
			\$	%
			\$	%
			\$	%
			\$	%
			\$	%
Must provide a detailed scope of work; one-word descriptions are not acceptable.		<b>TOTALS</b>	\$	%

**INTENT TO PERFORM AS A 1<sup>ST</sup> TIER DBE - FORM B**

The Bidder/Proposer/Prime is prohibited from completing any portion of this form and directing the DBE to sign a blank form.

DIRECTIONS: DBE(s) listed on the Form A must complete all information on this form.

Name of Bidder/Proposer/Prime: \_\_\_\_\_

Name of DBE Firm: \_\_\_\_\_

Project/Contract Name: \_\_\_\_\_

IFB/RFP Contract Number: \_\_\_\_\_

**Does the undersigned DBE (Answer Accordingly):**

Intend to perform subcontract work in connection with the above-mentioned project as a Joint Venture? Circle one. (Yes or No)

Intend to subcontract any portion of its scope of work to a DBE(s)?  
*If yes, DBE Sub-Primes must complete and submit Form AA.*

Circle one. (Yes or No)  
At what percent? \_\_\_\_\_%

Intend to subcontract any portion of its scope of work to a Non-DBE(s)?  
*If yes, must complete and submit Form AA2.*

Circle one. (Yes or No)  
At what percent? \_\_\_\_\_%

The undersigned will perform the following described work on the above-referenced project: *(Provide a detailed description of the type of work you will perform on your subcontract. Attach a copy of quote approved and signed by Bidder (optional)).*

Dollar Value of DBE Subcontract: \$ \_\_\_\_\_

Total Quantity/Units (if applicable): \_\_\_\_\_ Per Unit Cost (if applicable): \$ \_\_\_\_\_

The undersigned based the above scope of work and subcontract value on detailed project specs received from the Bidder contractor named above. Circle one. (Yes or No)

The Prime Contractor projected the following commencement and completion date for such work as follows:

DBE Contract Start Date: \_\_\_\_\_ DBE Contract Completion Date \_\_\_\_\_

The undersigned DBE will enter into a formal agreement for the above work with the Prime Contractor conditioned upon execution of a contract with NJ TRANSIT. As a DBE subcontractor, I will cooperate with the certification, compliance and monitoring process set forth by NJ TRANSIT. I attest that I will perform at least 51% of my subcontract with my own workforce for the referenced project.

Signature of 1<sup>st</sup> Tier DBE \_\_\_\_\_

Date

Title

Print Name

Telephone #:

Failure to adhere to these instructions or the falsification of any information on this form shall result in breach of contract and subject to the appropriate penalties to be determined by NJ TRANSIT.

ADDENDUM

**FORM D INSTRUCTION SHEET**  
**PRE AND POST AWARD GOOD FAITH EFFORT (IF APPLICABLE)**

**Required for all DBE subcontractors who decline to provide a quote.**  
**Applies in pre and post-award.**

**Important**

Bidder/proposer/prime compliance with contract goals and good faith efforts are handled as a matter of responsibility. If the bidder/proposer/prime did not meet the goal, they must document that they made Good Faith Efforts to do so. This requirement is an important and serious one. NJ Transit's Office of Business Diversity will make a fair and reasonable judgment as to whether the bidder made adequate Good Faith Efforts.

Bidders/proposers/primes are required to read the DBE Program Requirements and the guidelines/ instructions of all forms; and required to submit all forms in the Addendum (mandatory) and Supplemental Section (if applicable) with the bid/proposal or within seven (7) days after bid/proposal submission.

**Guidelines to Bidder/Proposer/Prime:**

- FORM D outlines actions that may be considered good faith efforts though it is not a mandatory checklist, nor is it intended to be exclusive or exhaustive. Please read DBE Program Requirements for further guidance.
- Bidder/Proposer/Prime must complete FORM D if and when it fails to meet the DBE goal.
- FORM D must be completed in this instance for any DBE firms which were solicited but declined to quote for the project.
- DBE firm must sign Page 2 of FORM D. If DBE declines to do so, submit completed form with bidder/proposer/prime signature only and the Office of Business Diversity will verify information with DBE.
- If/when the contract goal is not met, the fact that there may be some additional costs involved in finding and using DBEs is not in itself sufficient reason for a bidder's failure to meet the contract DBE goal, as long as such costs are reasonable. Prime contractors are not, however, required to accept higher quotes from DBEs if the price difference is excessive or unreasonable.
  - In short, unless the price difference is excessive or unreasonable, incurring additional costs in using and finding a DBE is not sufficient reason to reject the DBE quote or not to meet the contract goal.

**Instructions:**

- On Page 1 of FORM D, indicate with a check mark the various types of detailed good faith efforts made and attach documentation of such efforts. Types of acceptable documentation are listed on Page 2.
- Document any other type of good faith efforts not listed on Page 1.
- Complete this form entirely.

Bidders/proposers/primes are to provide the required forms and instruction sheet, including the Supplemental section to their 1<sup>st</sup> Tier DBE subs. DBE sub-primes must provide required forms under Supplemental section to their 2<sup>nd</sup> Tier DBE/Non-DBE subs, if applicable. Please contact the compliance officer identified for this contract at the pre-bid/proposal conference for guidance on completing any of these forms.



## DBE GOOD FAITH EFFORT- FORM D

IFB/RFP Number: \_\_\_\_\_

Project Title: \_\_\_\_\_

Bidder/Proposer/Prime Name: \_\_\_\_\_

Address: \_\_\_\_\_  
\_\_\_\_\_

Phone: \_\_\_\_\_ Email: \_\_\_\_\_

Date Signed: \_\_\_\_\_

The following is a list of the types of actions that may be considered good faith efforts. It is not intended to be a mandatory checklist, nor is it intended to be exclusive or exhaustive. Other factors or types of efforts may be relevant in appropriate cases, however please check all that apply in this instance. Please provide documentation for ALL instances selected.

- Selected portions of work to be performed by DBEs and, where appropriate, broke down contracts into economically feasible units to facilitate DBE participation.
- Provided interested DBE with adequate information about plans, specifications, and requirements of the contract.
- Negotiated in good faith with interested DBE, not rejecting DBEs as unqualified without sound reasons based on a thorough investigation of their capabilities.
- Made efforts to assist interested DBE in obtaining bonding, lines of credit, or insurance required by NJ Transit or Bidder.
- Made efforts to assist interested DBEs in obtaining necessary equipment, supplies, materials, or related assistance or services.
- Advertised subcontracting opportunities in appropriate media.
- Used the services of minority organizations, minority contractors' groups, local state and federal minority business assistance offices and other organizations that provide assistance identifying subcontractors.
- Provided written notice to DBEs in sufficient time to allow the DBE to respond. (Provide copy of documentation with Page 2.)
- Followed up initial solicitation of interest by contacting DBE to determine interest. (Provide proof of follow up with Page 2.)

Describe any other efforts not covered above that may indicate Good Faith Efforts to obtain DBE participation on this project and provide documentation.

**PRIME CONTRACTOR Monthly DBE Payment Report - Form E**

Name of Project: \_\_\_\_\_

NJT Contract #: \_\_\_\_\_

Prime Original Contract Value: \_\_\_\_\_

Report for the Month of: \_\_\_\_\_

Change Orders (Overall Inc/Dec.): \_\_\_\_\_

Notice to Proceed Date: \_\_\_\_\_

Total Contract Amount to Date: \_\_\_\_\_

NJT Project Mgr Name: \_\_\_\_\_

Total Payments Received from NJT Date: \_\_\_\_\_

Assigned DBE Goal %: \_\_\_\_\_

Name of DBE Subcontractor	Work Task Performed	Original Contract Amount \$	Change Order Amount \$ (+/-)	Amount of Invoice Received this Month (\$)	Date of Invoice Received in this Month	Payment(s) Made to DBE in this Month in \$\$ (Itemize)	Date(s) Payment Made This Month	Total DBE Payments made to Date in (\$)	% Overall Work Finished	Final Pmt (Y/N)
<b>Total(s)→</b>		\$	\$	\$	<b>Total(s)</b>	\$	<b>Total(s)</b>	\$		

Itemize payments/invoices and dates if paid/received more than one payment/invoice between the 1<sup>st</sup> and 31<sup>st</sup> of THIS Month.

**Prime Contractor Information:**

Prime Firm Name: \_\_\_\_\_

Project Director Name: \_\_\_\_\_

Address: \_\_\_\_\_

Project Director Signature: \_\_\_\_\_

Telephone #: \_\_\_\_\_ Date: \_\_\_\_\_

Federal TIN #: \_\_\_\_\_

**Prime's Past Due Invoice Information:** List any invoice more than 40 days past due from the date submitted to NJT at the time you complete this form.

Invoice #	Invoice Date	Invoice Amount (\$)	Number of Days Past Due	Comments:

**Form E - Prime Contractor's DBE Payment Certification**

1. Have all DBE subcontractors with executed subcontracts been paid amounts due from previous progress payments?

- If yes, skip the next section and go to number 3.
- If no, please complete fields in box below: (Use additional paper, if needed)

DBE SubContractor Name	Amount Withheld From Invoice (\$)	Total of Invoice Amount (\$)	Invoice Number	Invoice Date	Specific Reason for Withholding

2. Have you notified the DBE subcontractor(s) that you are withholding payment and the reason(s) why?

- If yes, provide a copy of written notification to the DBE subcontractor with this form, indicating the date of notification.
- If no, lack of prior written notification to the DBE(s) that you are withholding payment violates the prompt payment clause guidelines. Please contact the DBE immediately, and provide a copy of written notification to the subcontractor with this form.

3. By signing this form, I certify that all of the above represent true and accurate information.

Note: CFO or equivalent Sr. Manager must complete and sign off on this form.

\_\_\_\_\_  
PROJECT DIRECTOR NAME (PRINT)

\_\_\_\_\_  
PROJECT DIRECTOR (SIGNATURE)

\_\_\_\_\_/\_\_\_\_\_/\_\_\_\_\_  
DATE

Additional Reasons/Comments for Withholding Payment:

---



---

DO NOT WRITE BELOW. DEPARTMENTAL USE ONLY.

- Approved
- Denied

THIS FORM IS DUE ON THE 7TH OF EACH MONTH Please forward to:  
Office of Civil Rights and Diversity Programs  
Business Development  
NJ TRANSIT  
One Penn Plaza East, 6<sup>th</sup> Fl  
Newark, New Jersey 07105-2246

**DBE PRIME CONTRACTOR'S MONTHLY PAYMENTS FROM NJ TRANSIT  
INFORMATION ON CONTRACT**

DATE CONTRACT EXECUTED: \_\_\_\_\_ CONTRACT NUMBER: \_\_\_\_\_ REPORT FOR THE MONTH OF: \_\_\_\_\_ YEAR \_\_\_\_\_  
 ORIGINAL CONTRACT AMOUNT: \_\_\_\_\_ FED TAX ID #: \_\_\_\_\_  
 CHANGE ORDERS (OVERALL INC/DEC.): \_\_\_\_\_ PURCHASE ORDER #: \_\_\_\_\_  
 TOTAL CONTRACT AMOUNT TO DATE: \_\_\_\_\_ NAME OF PROJECT: \_\_\_\_\_

Original Contract Value	Change Order Amount +/-	Date of Change Order	New Contract Value	Payments Received This Month	Total Payments Received to Date	% Work Completed To Date	Final Pmt Y/N
<b>TOTALS:</b>							

**PRIME INVOICE 30 DAYS PAST DUE FROM NJT:**

**NJ TRANSIT**

Invoice Date      Reference #      No. Days Past Due      Amount

\_\_\_\_\_

\_\_\_\_\_

Project Manager (Name): \_\_\_\_\_

Telephone #: \_\_\_\_\_

**PRIME CONTRACTOR INFORMATION**

Firm Name: \_\_\_\_\_

Compliance Officer (Name): \_\_\_\_\_

Date: \_\_\_\_\_ Telephone #: \_\_\_\_\_

FORM IS DUE ON THE 7<sup>TH</sup> OF EACH MONTH.  
 PLEASE FORWARD TO:  
 NJ TRANSIT  
 Manager, Contract Compliance  
 Office of Business Diversity – 6<sup>TH</sup> FL  
 One Penn Plaza East  
 Newark, New Jersey 07105-2246

**DBE SUBCONTRACTOR Monthly Payment Report - Form E2**

Name of DBE Firm: \_\_\_\_\_  
 DBE's FEIN#: \_\_\_\_\_  
 DBE Address: \_\_\_\_\_  
 DBE Telephone #: \_\_\_\_\_

Report for the Month of: \_\_\_\_\_  
 Contract Number: \_\_\_\_\_  
 Contract Name: \_\_\_\_\_  
 DBE Contract Start Date: \_\_\_\_\_

**Prime Contractor's Information:**

Name of Prime: \_\_\_\_\_ Address: \_\_\_\_\_ Telephone #: \_\_\_\_\_

**DBE PAYMENT INFO:** *Itemize payments/invoices and dates if received/submitted more than one payment/invoice between the 1<sup>st</sup> and 31<sup>st</sup> of THIS Month.*

Work Task Performed	Original Subcontract Amount \$	Change Order Amount (+/-)	Invoice #(s) Submitted in this month	Dollar Amount of Each Invoice Submitted in this Month	Date of Invoice(s) Submitted this Month	Total Payments Received by DBE In this Month * (\$)	Date Payment(s) Received in this Month	Total Payments Received by DBE To Date (\$)	Total % Work To Date	Final Payment? Y or N
<b>TOTALS →</b>	\$	\$	<b>TOTALS→</b>	\$	<b>TOTALS→</b>	\$	<b>TOTALS→</b>	\$		

Is retainage held on your subcontract? **Yes** or **No** (circle one) If yes, how much? \$ \_\_\_\_\_. Did your final payment include retainage? **Yes** or **No** (circle one)

**Past Due Invoice(s) Information:** List any invoice more than 40 days past due from date submitted to prime at the time you complete this form.

Invoice #	Invoice Date	Invoice Amount (\$)	Number of Days Past Due	Comments: use additional paper if necessary

*Note: CFO or equivalent Sr. Manager must complete and sign off on this form.*

Name: \_\_\_\_\_ Signature: \_\_\_\_\_ Title: \_\_\_\_\_ Date: \_\_\_\_\_

THIS FORM IS DUE ON THE 7<sup>TH</sup> OF EACH MONTH IMMEDIATELY FOLLOWING DBE's SUBCONTRACT START DATE, EVEN IF PAYMENT NOT RECEIVED.

**Please mail this form to:**  
 NJ TRANSIT, Office of Business Development, One Penn Plaza East, 6<sup>th</sup> Fl, Newark, New Jersey 07105-2246

## **SUPPLEMENTAL SECTION REQUIRED FORMS**

**ENCLOSED FOR COMPLETION (IF APPLICABLE):**

- **Form AA; AA1; AA2; BB; & Trucking Commitment Schedule**

**TO BE OBTAINED AND SUBMITTED (IF APPLICABLE):**

- **Copy of a valid NJUCP DBE Certificate (Provided by 2<sup>nd</sup> Tier DBEs.)**

Consult DBE Program Requirements for further guidance.

**SECOND TIER DBE UTILIZATION-- FORM AA**

Project Name: \_\_\_\_\_

NJT Contract No: \_\_\_\_\_

DBE Sub-Prime (First Tier) Subcontractor Contract Value (\$): \_\_\_\_\_

I plan to subcontract \_\_\_\_\_% of my subcontract to Second Tier DBE subcontractor(s)/subconsultant(s) listed on the chart below to perform/supply the following:

*Second Tier DBE subs must perform 100% of their scope of work.*

Name, Address and Telephone # of Second Tier DBE Subcontractor/Subconsultant	Provide <u>Detailed</u> Scope of Work to be Performed	Dollar Value of Subcontractor/Subconsultant Work (\$) Awarded	Percentage of Subcontractor Work (%)
			%
			%
			%
Any First-Tier DBE firm listed on the Form A must identify any DBE firm it will use to perform its scope of work.	<b>TOTALS</b>	\$	%

The undersigned understands its approval to perform on the above contract is based upon its identified DBE team listed above and its Non-DBE team listed on the Form AA2. The DBE Sub-Prime must receive written approval from the Office of Business Development for any changes to its DBE and/or Non-DBE subcontractors, their dollar values or scope of work identified on the Form AA and/or AA2 before making any changes. It attests that the identified firms will perform all work. Failure to adhere to, or falsification of any information contained herein shall result in breach of contract and subject to corrective action to be determined by NJ TRANSIT.

DBE Sub-Prime Firm: \_\_\_\_\_

Authorized Signature: \_\_\_\_\_

Company Address: \_\_\_\_\_

Print Name: \_\_\_\_\_

\_\_\_\_\_

Title: \_\_\_\_\_

Federal Tax ID #: \_\_\_\_\_

Sub-Prime's DBE Liaison Officer: \_\_\_\_\_

Company Tel #: \_\_\_\_\_

Date Signed: \_\_\_\_\_

**BIDDER SOLICITATION & CONTRACTOR INFORMATION - FORM AA1**

VJT Contract No: \_\_\_\_\_  
 DBE Sub-Prime: \_\_\_\_\_  
 Date: \_\_\_\_\_

Project Title: \_\_\_\_\_  
 Telephone #: \_\_\_\_\_

*Complete the information below for Second Tier contractor(s) participating on the project.*

	Subcontractor/Subconsultant	Subcontractor/Subconsultant	Subcontractor/Subconsultant
Company's Full Name			
Address			
City			
Zip			
County			
Phone			
Fax			
E-mail			
Owner			
Date Established			
Date Certified			
Ethnicity			
Gender			
Certification Status: DBE or Non-DBE			
Federal Tax ID # / SSN #			
Annual Gross Receipts: A - Less than \$500K B - \$500K to \$1M C - \$1M to \$2M D - \$2M to \$5M E - \$5M and over indicate the letter that applies			
Primary NAICS Code:			



**NON-DBE SECOND TIER SUBCONTRACTOR UTILIZATION - FORM AA2**

*Directions: To be completed by any DBE Sub-Prime Contractor for "all" subs including suppliers participating on this contract.*

NJ Transit Contract No: \_\_\_\_\_ Date: \_\_\_\_\_ DBE Sub-Prime Contract Value: \$ \_\_\_\_\_

DBE Sub-Prime Contractor Name: \_\_\_\_\_ Project Title: \_\_\_\_\_

Name, Address and Telephone # of all Second Tier Subcontractor(s)/Subconsultant(s)	FEIN #	Provide <u>Detailed</u> Scope of Work to be Performed	Dollar Amount of Subcontractor/Subconsultant Work (\$) Awarded	Percentage of Subcontractor Work (%)
			\$	%
			\$	%
			\$	%
			\$	%
			\$	%
<b>Must provide a detailed scope of work; one-word descriptions are not acceptable.</b>		<b>TOTALS</b>	\$	%

**INTENT TO PERFORM AS A SECOND TIER DBE - FORM BB**

**The Bidder is prohibited from completing any portion of this form and directing the DBE to sign a blank form.**  
**DIRECTIONS:** DBE(s) listed on the Form AA must complete all information on this form and must complete Form AA2 for any Non-DBE subcontractor performing a portion of its subcontract.

\_\_\_\_\_  
 Name of First Tier DBE/Sub-Prime:

\_\_\_\_\_  
 Name of Second Tier DBE Firm:

Project/Contract Name: \_\_\_\_\_

IFB/RFP Contract Number: \_\_\_\_\_

Does the undersigned intend to perform subcontract work in connection with the above-mentioned project as a Joint Venture? Circle one. (Yes or No)

Will you subcontract any portion of your scope of work to a DBE(s)? Circle one. (Yes or No)

Will you subcontract any portion of your scope of work to a Non-DBE(s)? Circle one. (Yes or No)

The undersigned will perform the following described work on the above-referenced project: *(Provide a detailed description of the type of work you will perform on your subcontract. Attach a copy of quote approved and signed by Bidder (optional)).*

\_\_\_\_\_  
 Dollar Value of DBE Subcontract: \$ \_\_\_\_\_

Total Quantity/Units (if applicable): \_\_\_\_\_ Per Unit Cost (if applicable): \$ \_\_\_\_\_

The undersigned based the above scope of work and subcontract value on detailed project specs received from the DBE Sub-Prime named above. Circle one. (Yes or No)

The Prime Contractor *projected* the following commencement and completion date for such work as follows:

DBE Contract Start Date: \_\_\_\_\_ DBE Contract Completion Date \_\_\_\_\_

**The undersigned DBE will enter into a formal agreement for the above work with the DBE Sub-Prime conditioned upon execution of a contract with the Prime on the project. As a Second Tier DBE subcontractor, I will cooperate with the certification, compliance and monitoring process set forth by NJ TRANSIT. I attest that I will perform 100% of my subcontract with my own workforce for the referenced project.**

\_\_\_\_\_  
 Signature of Second Tier DBE

\_\_\_\_\_  
 Date

\_\_\_\_\_  
 Title

\_\_\_\_\_  
 Print Name

\_\_\_\_\_  
 Telephone #:

Failure to adhere to these instructions or the falsification of any information on this form shall result in breach of contract and subject to the appropriate penalties as determined by NJ TRANSIT.

## DBE TRUCKING COMMITMENT AGREEMENT

The DBE Trucking Firm Commitment Agreement sheet attached must be signed and completed entirely. Make duplicate copies for additional subcontractors as needed. Please read DBE Requirement Language for details.

- DBEs must provide information for all DBE/Non-DBE trucking firms it will lease from or subcontract to.
  - *Subcontracting to a Non-DBE trucker means that the Non-DBE will perform a portion of the DBE firm's subcontract.*
  - *2<sup>nd</sup> Tier DBE trucking firms must perform 100% of their total subcontract value.*
- For Non-DBE leased trucks, credit will only be given for the fee/commission that is received for arranging the transportation services.
  - *All DBE-leased trucks are required to reflect the DBE firm's company name and identification number.*

**Copies of the following items must be attached for ALL trucks owned by the DBE:**

- Proof of ownership: title(s) or finance agreement(s) ONLY
- registration card(s)
- insurance card(s)
- hazardous waste license(s), if applicable
- apportioned cab card(s), if applicable

**Copies of the following items must be attached for ALL DBE/non-DBE trucks leased by the DBE:**

- lease agreement(s)
- title(s)
- registration card(s)
- insurance card(s)
- hazardous waste license(s), if applicable
- apportioned cab card(s), if applicable





# NJ TRANSIT IFB No. 16-042X

One Penn Plaza East  
Newark, New Jersey 07105-2246

## BIDDERS PREQUALIFICATION

**FIRM NAME** \_\_\_\_\_

\_\_\_\_\_ An Individual      \_\_\_\_\_ A Partnership      \_\_\_\_\_ A Corporation

Mailing Address \_\_\_\_\_  
\_\_\_\_\_

Telephone No. (      ) \_\_\_\_\_ Federal Employee Identification No. \_\_\_\_\_

Fax No. (      ) \_\_\_\_\_ DUNS No. \_\_\_\_\_

To be completed for partnership. Date of organization _____	
State whether partnership is general, limited or association _____	
NAMES OF PARTNERS	ADDRESS
_____	_____
_____	_____
_____	_____

To be completed for a corporation. Date incorporated _____	
State _____ Capital paid in cash _____	
If not incorporated in New Jersey - Date of Certificate of Authority to perform work in New Jersey _____	
Present officers of the corporation:	
NAME	ADDRESS
President _____	_____
Vice President _____	_____
Secretary _____	_____
Treasurer _____	_____

**REGISTERED AGENT IN NEW JERSEY:** \_\_\_\_\_

Provide name and address of registered agent authorized to represent the firm in the State of New Jersey.

### RELATED STATE OF NEW JERSEY PREQUALIFICATION

\_\_\_\_\_ NJ Department of Transportation      \_\_\_\_\_ NJ Department of the Treasury  
Division of Property Management and Construction

If prequalified by either of the above, attach copy of the current Notice of Classification.

## BIDDERS PREQUALIFICATION INSTRUCTIONS AND GENERAL INFORMATION

1. Pursuant to New Jersey Transit Corporation (NJ TRANSIT) Procurement Regulations certain Bidders must be prequalified prior to submitting a bid.
2. Please note that all Out-of-State companies contracting with NJ TRANSIT must have a registered agent in the State of New Jersey. If you do not have a registered agent or you have changed your registered agent since filing for a Business Registration Certificate with the State of New Jersey, contact the Secretary of State of New Jersey at (609) 984-1900.
3. Fill out the attached forms, answering each question fully and completely. Joint venturers must execute and submit a "Statement of Joint Venture" form, available from NJ TRANSIT's Procurement Department.
4. Please be advised that this Prequalification applies to sealed bids only. Approval will not constitute acceptance of any bid, license or contract. NJ TRANSIT reserves the right to rescind any prequalification approval and reject any and all bids.
5. Prospective Bidders will be classified according to the type of work and the amount of work on which they are entitled to bid. Factors considered in the evaluation process include, but are not limited to:
  - Technical Qualifications and Experience - demonstrated ability to successfully manage performance of work of the type for which qualification is requested.
  - Financial Resources - financial status, value of projects successfully completed, bonding capacity, accounting and auditing procedures, etc.
  - Organization - experience of key personnel, years in business, record of integrity, etc.
  - References
6. Each prospective bidder will be classified for one or more types of work in accordance with its financial ability, organization, record of work, and any other pertinent and material facts which may affect such classification. The prospective bidder will be assigned classification(s) which will designate the type and quantity of work upon which it will be eligible to bid. NJ TRANSIT will give notice of such classification(s) after receipt and evaluation of the fully completed prequalification questionnaire, or after receipt of any additional information requested. An applicant who fails to furnish any of the information requested in the questionnaire will not be classified to submit bids for work to be awarded on contract by NJ TRANSIT.
7. Bids will be accepted only from prospective bidders that have been assigned a classification. Under no circumstances will bids be accepted from bidders that have not been classified, nor for work different in type or greater in amount than that to which the classification of the bidder entitles it. When a doubt arises as to whether a bid is within the class for which the bidder is qualified, the bid will be opened provisionally, and if it appears that the bid is, in fact, not within the class to which the prospective bidder is classified, the bid will be immediately excluded.
8. When a prospective bidder has been assigned a classification, it shall be entitled to bid on any project within its class for a period not exceeding thirty six (36) months from the date shown upon its Classification Notice. The Dollar Limit of the classification assigned applies to each individual project bid and is not an aggregate value.

9. NJ TRANSIT may establish special classification requirements for a particular project, or class of projects, when deemed necessary.
10. Where multiple contractors, each holding a valid classification from NJ TRANSIT, propose to form a joint venture for the purposes of bidding on a project, the joint venturers shall execute and submit a "Statement of Joint Venture" form. The classification limit for the joint venture shall be no greater than the lower of 1) the combined value of their respective classifications or 2) the bonding capacity of the joint venture. The Joint Venture must notify NJ TRANSIT of its intent to bid as a joint venture at least fourteen (14) days prior to the date set for receipt of bids on the project. Failure to provide such notice within the prescribed time may be cause for rejection of the bid as nonresponsive.
11. NJ TRANSIT may reject any bid at any time prior to the actual award of a contract where there have been developments subsequent to qualification and classification which, in the opinion of NJ TRANSIT would affect the Responsibility of the Bidder. Before taking such action, NJ TRANSIT will notify the bidder and give such bidder an opportunity to present additional information.
12. In the event a corporation not incorporated in the State of New Jersey is the lowest bidder, it must be authorized to do business in New Jersey pursuant to N.J.S.A. 14:15-1 et seq., before the contract will be executed by NJ TRANSIT. All corporations, firms and individuals from outside the State of New Jersey are required to designate a resident of New Jersey to accept process in case of litigation before the contract is approved.
13. If a prospective bidder objects to its assigned classification, it may request a reconsideration of the assigned classification by writing to the Director of Contracts within 15 calendar days after the date of the Classification Notice.
14. Prequalification by the NJ TRANSIT Procurement Department does not constitute certification of the firm as a DBE/SBE/ESBE. Certification of DBE/SBE/ESBE status is performed by NJ TRANSIT's Office of Business Diversity Certification and Outreach. All requests concerning certification approval as a Small/Disadvantaged Business Enterprise must be directed to the Director, Business Diversity Certification and Outreach, Office of Business Diversity Certification and Outreach Programs, One Penn Plaza East, Newark, New Jersey 07105-2246.
15. Recent letters from banks, certifying to the establishment of lines of credit, may be submitted for the purpose of augmenting financial qualifications. Such letters must be on regular bank letterhead and must be specific as to the amount of the line of credit approved and the total amount of loans outstanding at the present time against this line of credit.
16. On all matters of classification or appeal of classification, the decision of NJ TRANSIT's, Senior Director, Contracts Unit is final.
17. A Bidder to be prequalified to perform construction work in an "Operating Railroad Environment" shall have identified in their Bidder's Prequalification Questionnaire specific completed projects which demonstrate construction experience working on an FRA regulated high speed commuter or passenger railroad, in both an electrified and diesel fuel environment, working on or within four feet of the active railroad tracks.
18. Prospective Bidders seeking prequalification with NJ TRANSIT must be registered and active with the System for Award Management (S.A.M). To register please go to [www.SAM.gov](http://www.SAM.gov) and follow the registration instructions.



# NJ TRANSIT

Please identify the type(s) of work for which prequalification is requested and a request for the amount per project on which the applicant would be entitled to bid.

A. As to the Type of Work:

- HC - Heavy Construction **(Non-Operating Railroad Environment)**
  - GC - General Contractor, includes management of multiple subcontractors performing work in the subcategories identified below.
    - EC - Excavation and Clearing
    - GP - Grading & Paving
    - DM - Demolition
    - BG - Bridges & Related Structures
    - BB - Boring/Blasting
    - PD - Pile Driving
    - UU - Underground Utilities, Lighting
    - LS - Landscaping
    - CM - Concrete/Masonry
    - SP - Specialty-Other, please specify \_\_\_\_\_
- HR - Heavy Construction-Rail **(Operating Railroad Environment)**
  - GC - General Contractor, includes management of multiple subcontractors performing work in the subcategories identified below.
    - EC - Excavation and Clearing
    - GP - Grading & Paving
    - DM - Demolition
    - BG - Bridges & Related Structures
    - MB - Moveable Bridges
    - BB - Boring/Blasting
    - PD - Pile Driving
    - UU - Underground Utilities, Lighting
    - LS - Landscaping
    - CM - Concrete/Masonry
    - TW - Trackwork
    - SW - Signal Work
    - ET - Catenary/Electrification
    - SP - Specialty-Other, please specify \_\_\_\_\_
- BC - Building Construction **(Non-Operating Railroad Environment)**
  - GC - General Contractor, includes management of multiple subcontractors performing work in the subcategories identified below.
    - EE - Electrical (copy of license must be attached)
    - DM - Demolition
    - PB - Plumbing (copy of license must be attached)
    - HV - HVAC, Mechanical Systems
    - IS - Iron/Steel Erection
    - FP - Fire Protection (requires certification)
    - RF - Roofing
    - SP - Specialty-Other, please specify \_\_\_\_\_

# NJ TRANSIT

- \_\_\_\_\_ BR - Building Construction-Rail **(Operating Railroad Environment)**
- \_\_\_\_\_ GC - General Contractor, includes management of multiple subcontractors performing work in the subcategories identified below.
  - \_\_\_\_\_ EE - Electrical (copy of license must be attached)
  - \_\_\_\_\_ DM - Demolition
  - \_\_\_\_\_ PB - Plumbing (copy of license must be attached)
  - \_\_\_\_\_ HV - HVAC, Mechanical Systems
  - \_\_\_\_\_ IS - Iron/Steel Erection
  - \_\_\_\_\_ FP - Fire Protection (requires certification)
  - \_\_\_\_\_ RF - Roofing
  - \_\_\_\_\_ SP - Specialty-Other, please specify \_\_\_\_\_
- \_\_\_\_\_ ES - Environmental Services
  - \_\_\_\_\_ HW - Hazardous Material Removal
  - \_\_\_\_\_ AR - Asbestos Removal (copy of license must be attached)
  - \_\_\_\_\_ UT - Underground Tank Removal/Installation – (requires DEP certification)
  - \_\_\_\_\_ WT - Water Treatment – (requires DEP license)
  - \_\_\_\_\_ SP - Specialty-Other, please specify \_\_\_\_\_
- \_\_\_\_\_ MC - Marine Construction
  - \_\_\_\_\_ GC - General Contractor, including fender systems, piers, dredging, etc.
  - \_\_\_\_\_ SP - Specialty-Other, please specify \_\_\_\_\_
- \_\_\_\_\_ MG - Manufacturing
  - \_\_\_\_\_ BS - Bus Rolling Stock
  - \_\_\_\_\_ RS - Rail Rolling Stock
  - \_\_\_\_\_ EQ - Equipment-Other, please specify \_\_\_\_\_

**B. As to the Amount of Work:**

_____ A \$ 50,000 to \$ 100,000	_____ J \$ 2,000,001 to \$ 3,000,000
_____ B 100,001 to 150,000	_____ K 3,000,001 to 4,000,000
_____ C 150,001 to 200,000	_____ L 4,000,001 to 6,000,000
_____ D 200,001 to 300,000	_____ M 6,000,001 to 8,000,000
_____ E 300,001 to 400,000	_____ N 8,000,001 to 10,000,000
_____ F 400,001 to 500,000	_____ O 10,000,001 to 15,000,000
_____ G 500,001 to 750,000	_____ P 15,000,001 to 20,000,000
_____ H 750,001 to 1,000,000	_____ Q 20,000,001 to 25,000,000
_____ I 1,000,001 to 2,000,000	_____ R Over 25,000,000

# NJ TRANSIT

**I. FINANCIAL STATUS (as of \_\_\_\_\_ )**

Fill in appropriate blanks in Financial Status form.

Aggregate Bonding Amount: \$ \_\_\_\_\_ Single Project Bonding Amount: \$ \_\_\_\_\_

Value of Ongoing Contracts: \$ \_\_\_\_\_

**QUICK ASSETS**

**(Omit Cents)**

Cash		\$ _____
Notes Receivable		\$ _____
Accounts Receivable from Construction Contracts		\$ _____
Retainage		\$ _____
Accounts Receivable, not from Construction Contracts		\$ _____
Inventories		\$ _____
Other Quick Assets (specify): _____		\$ _____
_____		\$ _____
_____		\$ _____
_____		\$ _____
_____		\$ _____
<b>TOTAL QUICK ASSETS</b>		<b>\$ _____</b>

**CURRENT LIABILITIES (Due within 12 Months)**

Notes and Mortgages Payable		\$ _____
Accounts Payable		\$ _____
Other Current Liabilities		\$ _____
<b>TOTAL CURRENT LIABILITIES</b>		<b>\$ _____</b>
<b>NET QUICK ASSETS</b>		<b>\$ _____</b>

**AVAILABLE LINE OF CREDIT (attach letter from bank)**

See Note 15 of the Bidders Prequalification Instructions and General Information.

<b>POTENTIAL QUICK ASSETS</b>		<b>\$ _____</b>
-------------------------------	--	-----------------

# NJ TRANSIT

## II. RELATED PROJECT EXPERIENCE

Fill in complete information for at least five (5) projects finished recently for which the organization performed the type of work for which prequalification is requested.

Project Name: \_\_\_\_\_

Contract Price: \$ \_\_\_\_\_

Date Completed: \_\_\_\_\_

Type of Work: \_\_\_\_\_

Client: \_\_\_\_\_

Contact Person: \_\_\_\_\_

Telephone No.: (    ) \_\_\_\_\_

Fax No.: (    ) \_\_\_\_\_

Project Name: \_\_\_\_\_

Contract Price: \$ \_\_\_\_\_

Date Completed: \_\_\_\_\_

Type of Work: \_\_\_\_\_

Client: \_\_\_\_\_

Contact Person: \_\_\_\_\_

Telephone No.: (    ) \_\_\_\_\_

Fax No.: (    ) \_\_\_\_\_

Project Name: \_\_\_\_\_

Contract Price: \$ \_\_\_\_\_

Date Completed: \_\_\_\_\_

Type of Work: \_\_\_\_\_

Client: \_\_\_\_\_

Contact Person: \_\_\_\_\_

Telephone No.: (    ) \_\_\_\_\_

Fax No.: (    ) \_\_\_\_\_

Project Name: \_\_\_\_\_

Contract Price: \$ \_\_\_\_\_

Date Completed: \_\_\_\_\_

Type of Work: \_\_\_\_\_

Client: \_\_\_\_\_

Contact Person: \_\_\_\_\_

Telephone No.: (    ) \_\_\_\_\_

Fax No.: (    ) \_\_\_\_\_

Project Name: \_\_\_\_\_

Contract Price: \$ \_\_\_\_\_

Date Completed: \_\_\_\_\_

Type of Work: \_\_\_\_\_

Client: \_\_\_\_\_

Contact Person: \_\_\_\_\_

Telephone No.: (    ) \_\_\_\_\_

Fax No.: (    ) \_\_\_\_\_

# NJ TRANSIT

### III. ORGANIZATIONAL EXPERIENCE

What is the experience of the principal individuals of your organization?

INDIVIDUAL'S NAME	PRESENT POSITION OR OFFICE	YEARS IN ORGANIZATION	YEARS OF EXPERIENCE	MAGNITUDE & TYPE OF WORK	IN WHAT CAPACITY?

Provide name and telephone number of the Equal Employment Opportunity Officer for your firm:

---

How many years experience has your organization had as a:

Prime Contractor \_\_\_\_\_

Subcontractor \_\_\_\_\_

**ELECTRICAL CONTRACTOR LICENSE NO.** \_\_\_\_\_

If an electrical contractor, provide State of New Jersey license number and attach copy of license.

**PLUMBING CONTRACTOR LICENSE NO.** \_\_\_\_\_

If a plumbing contractor, provide State of New Jersey license number and attach copy of license.

**ASBESTOS LICENSE**

If an asbestos abatement contractor/ASTM, attach copy of the appropriate license from the State of New Jersey Department of Labor.

# NJ TRANSIT

## IV. PERFORMANCE AND INTEGRITY

Has the entity seeking prequalification ever failed to complete any work awarded?

No \_\_\_\_\_ Yes \_\_\_\_\_ (Attach a detailed explanation of each instance)

Is the entity seeking prequalification or any owner, partner, officer or manager of same currently suspended or debarred from performing contracts in the State of New Jersey or by any other federal, state, or local governmental jurisdiction?

No \_\_\_\_\_ Yes \_\_\_\_\_ (Attach a detailed explanation stating name of individual or organization, the governmental jurisdiction, the reason for the suspension/debarment and the time period for which it is effective)

On any project within the last five years in which the entity seeking prequalification was the prime contractor did the public or private owner file a claim against the performance/payment bond furnished for said project?

No \_\_\_\_\_ Yes \_\_\_\_\_ (Attach a detailed explanation of each instance)

Has the entity seeking prequalification or any owner, partner, officer or manager of same been cited by any federal, state or local agency, department or bureau with environmental, safety, and/or health violations within the last five years?

No \_\_\_\_\_ Yes \_\_\_\_\_ (Attach a detailed explanation of each instance)

Has the entity seeking prequalification or any owner, partner, officer or manager of same been charged, arrested, indicted or convicted of embezzlement, theft, forgery, bribery, falsification or destruction of records, perjury, false swearing, receiving stolen property, obstruction of justice or any other offense indicating a lack of business integrity or honesty?

No \_\_\_\_\_ Yes \_\_\_\_\_ (Attach a detailed explanation of each instance)

Has the entity seeking prequalification or any owner, partner, officer or manager of same been charged, arrested indicted or convicted of a violation of the Federal Organized Crime Control Act of 1970; Federal or State Antitrust statutes or the Anti-Kickback Act (18 U.S.C. 874, 40 U.S.C. 276b)?

No \_\_\_\_\_ Yes \_\_\_\_\_ (Attach a detailed explanation of each instance)

Has the entity seeking prequalification or any owner, partner, officer or manager of same been charged, arrested, indicted or convicted of a violation of any of the Federal or State laws governing hours of labor, minimum wage standards, prevailing wage standards, discrimination in wages, child labor or immigration?

No \_\_\_\_\_ Yes \_\_\_\_\_ (Attach a detailed explanation of each instance)

# NJ TRANSIT

## V. STOCKHOLDER LIST CERTIFICATION AND CORPORATION INFORMATION

The list below contains the names and home addresses of all stockholders holding ten percent (10%) or more of the issued and outstanding stock of the corporation. If one or more such stockholder or partner is itself a corporation or partnership, the stockholder holding ten percent (10%) or more of that corporation's stock, or the individual partners owning ten percent (10%) or greater interest in that partnership, as the case may be, must also be listed.

### STOCKHOLDERS

Name \_\_\_\_\_

Home Address \_\_\_\_\_

\_\_\_\_\_

Name \_\_\_\_\_

Home Address \_\_\_\_\_

\_\_\_\_\_

Name \_\_\_\_\_

Home Address \_\_\_\_\_

\_\_\_\_\_

Name \_\_\_\_\_

Home Address \_\_\_\_\_

\_\_\_\_\_

Name \_\_\_\_\_

Home Address \_\_\_\_\_

\_\_\_\_\_

Name \_\_\_\_\_

Home Address \_\_\_\_\_

\_\_\_\_\_

Is the firm a subsidiary of a parent corporation? \_\_\_\_\_

Name of Parent Corporation \_\_\_\_\_

Address \_\_\_\_\_

Date Incorporated-State Incorporated \_\_\_\_\_

Name & Address of Registered Agent \_\_\_\_\_

\_\_\_\_\_

# NJ TRANSIT

## V. STOCKHOLDER LIST CERTIFICATION AND CORPORATION INFORMATION (continued)

Is parent corporation owner of all assets of subsidiary? \_\_\_\_\_  
If not, identify all owners and percentage of ownership. \_\_\_\_\_  
\_\_\_\_\_  
\_\_\_\_\_

Stockholders holding 10% or more of issued and outstanding stock of Parent Corporation are to be listed above.

## VI. CERTIFICATION

I, \_\_\_\_\_ being of full age, hereby certify as follows:

I am authorized to execute this certification for and on behalf of the individual, partnership or corporation herein first named as applicant for a classification by the New Jersey Transit Corporation.

The forgoing information and any attachments thereto to the best of my knowledge are true and complete.

Any depository, vendor or other agency herein named is hereby authorized to supply New Jersey Transit Corporation with any information necessary to verify any statement made herein.

In addition to an agreement to comply with an Affirmative Action Program as required by New Jersey Public Law 1975, Chapter 127 for equal employment opportunity as part of classification requirements, we do hereby further affirm that we will comply with the rules and regulations which are and/or may be promulgated by the State Treasurer pursuant to the Affirmative Action Law (P.L. 1975, c.127) as amended and supplemented.

I certify that the applicant recognizes that one of the criteria in determining a "responsible" bidder under New Jersey Transit Corporation contract specifications is active compliance with the aforesaid Equal Employment Opportunity Program and that documentation required by this program, as evidence of compliance, may be inspected at the applicant's offices.

I hereby certify that the foregoing statements made by me are true. I am aware that if any of the foregoing statements made by me are willfully false, I am subject to punishment.

Signature: \_\_\_\_\_

Date: \_\_\_\_\_

Print Name: \_\_\_\_\_

Print Title: \_\_\_\_\_

E-mail Address: \_\_\_\_\_



**BID BOND**

KNOW ALL MEN BY THESE PRESENTS, that we, the undersigned \_\_\_\_\_

\_\_\_\_\_ as PRINCIPAL, and \_\_\_\_\_

\_\_\_\_\_ a corporation organized and existing under the laws of the State of \_\_\_\_\_

and duly authorized to do business in the State of New Jersey, as SURETY, are held and firmly bound unto the New Jersey Transit Corporation in the penal sum of ten percent (10%) of the amount bid for the project(s) listed below, for the payment of which well and truly to be made, we hereby jointly and severally bind ourselves, our heirs, executors, administrators, successors and assigns.

Signed, sealed, and dated this \_\_\_\_\_ day of \_\_\_\_\_ two thousand and \_\_\_\_

\_\_\_\_\_.

The condition of the above obligation is such that whereas the principal is herewith submitting a proposal for:

**SEALED BID NO. \_**

NOW, THEREFORE, THE CONDITION OF THE ABOVE OBLIGATION IS SUCH, that if the said principal shall execute a contract and give bond for the faithful performance thereof within ten (10) state business days after being notified in writing of the award of such contract to principal, or if the principal or surety shall pay the obligee the sum, not exceeding the penalty hereof, by which the amount of the contract, covering the said proposal, properly and lawfully executed by and between the obligee and some third party, may exceed the amount bid by principal, then this obligation shall be void; otherwise it shall remain in full force and effect.

Witness or Attest:

\_\_\_\_\_

\_\_\_\_\_

\_\_\_\_\_

\_\_\_\_\_

(Principal)

\_\_\_\_\_

Witness or Attest:

\_\_\_\_\_

\_\_\_\_\_

\_\_\_\_\_

(Surety)

Certification to the Authority of the attorney in fact to commit the surety company must accompany this Bond, and true and correct statement of the financial condition of said surety company.

PREVAILING WAGE SCHEDULES FOR THIS PROJECT ARE NOT REPRINTED  
HERE DUE TO SIZE

SPECIFICATIONS FOR THIS PROJECT ARE NOT REPRINTED HERE DUE TO  
SIZE