



State of New Jersey

DEPARTMENT OF TREASURY
DIVISION OF PROPERTY MANAGEMENT & CONSTRUCTION
P O BOX 034
TRENTON NJ 08625-0034

PHILIP D. MURPHY
Governor

SHEILA Y. OLIVER
Lt. Governor

ELIZABETH MAHER MUOIO
State Treasurer

CHRISTOPHER CHIANESE
Director

July 25, 2023

E.E. Cruz & Company, Inc.
16-16 Whitestone Expressway, 5th Floor
Whitestone, NY 11357

Re: Project #P1155-02 Re-Bid, Re-Build By Design – Resist Alignment, Hudson River Project
Hoboken, Weehawken and Jersey City, NJ – Hudson County
Award Amount: \$251,205,588.

The State of New Jersey intends to accept your bid price on the above referenced project. **The contract award meeting is scheduled for Monday, July 31, 2023 at 10:00 a.m. The meeting will be held in the DPMC Offices located at 33 W. State Street, 9th Floor, Trenton, NJ 08608.**

Enclosed are the original and two copies of the formal contract to be signed by an official of the firm and witnessed by a member of your staff. Please affix the corporate seal if required. **Contracts must be returned by the contract award date with the properly executed performance and payment bonds and the required proof of insurance.** Sample forms of the bonds were provided by email (submit two originals of each bond). **The bonds must be dated on or before the date of the contract award.**

Two copies of the insurance certificate must be produced naming your firm as the insured and listing the State of New Jersey as the Additional Insured (See Article 13.4 of the General Conditions). The insurance certificates must also be dated on or before the date of the contract award.

You shall perform no work under the contract until the required evidence of financial responsibility and bonds have been furnished. Thereafter, work other than that at the contract site may be undertaken. You shall perform no work at the site except pursuant to a Notice to Proceed issued by the Contracting Officer.

The State of New Jersey recently introduced a new payment procedure for all vendors. In order to process invoices for payment contractors must register on NJ START. Please go to www.njstart.gov to register your business online.

Time extensions for completion of the work will not be granted due to a failure to comply with these procedures.

Should you have any questions regarding the above, please contact this office at (609) 292-5229.

Sincerely,

Christopher R. Geary
Assistant Deputy Director
Contracts and Procurement

CONTRACT

THIS AGREEMENT, made this 31st day of July, 2023

by and between The State of New Jersey, herein called "owner," acting herein through its
(Corporate Name of Owner)

Division of Property Management and Construction, Deputy Director, , and
(Title of Authorized Official)

E.E. CRUZ & COMPANY, INC.

(a corporation)

of 16-16 Whitestone Expressway, 5th floor, City of Whitestone, County of Queens, and State of New York
hereinafter called "Contractor". (FID#22250166400)

WITNESSETH: That for and in consideration of the payments and agreements hereinafter mentioned, to be made and performed by the OWNER, the CONTRACTOR hereby agrees with the OWNER to commence and complete the construction described as follows:

CONTRACT PROJECT NO.: **P1155-02-RE-BID-CC01**
RE-BUILD BY DESIGN
HUDSON RIVER COASTAL DEFENSE – RESIST ALIGNMENT
HUDSON COUNTY – HOBOKEN, JERSEY CITY & WEEHAWKEN
NEW JERSEY

TOTAL OF BASE BID UNIT PRICES\$209,656,188.
Add Alt. #1A.. \$ 41,549,400.
Net Award \$251,205,588.

- SPECIFICATIONS: Dated June 2022 included as part of this contract
- UNIT PRICES: Submitted on pages 5 through 21 of 25 of the Bid Proposal Form, included as part of this contract
- ALTERNATES: Submitted on page 21 of 25 of the Bid Proposal Form, included as part of this contract
- ALLOWANCES: Submitted on pages 16, 17, 18 and 21 of 25 of the Bid Proposal Form, included as part of this contract
- BULLETINS: "A" dated 06-28-21, "B" dated 07-12-21, "C" dated 08-03-22, "D" dated 08-03-22, "E" dated 08-03-22, "F" dated 08-03-22, "G" dated 08-26-22, "H" dated 09-01-22, "I" dated 09-08-22, "J" dated 09-27-22, "K" dated 10-06-22, "L" dated 10-18-22, "M" dated 10-20-22, "N" dated 11-16-22, "O" dated 11-22-22, "P" dated 12-13-22, "Q" dated 12-20-22, "R" dated 01-05-23, "S" dated 01-26-23, "T" dated 02-23-23, "U" dated 04-18-23 and "V" dated 05-25-23 have been acknowledged by the bidder and included as part of this contract
- GEN.CONDITIONS: Instructions to Bidders & General Conditions for Hudson River Rebuild by Design dated Revised June 2022, included as part of this contract
- DRAWINGS: See cover sheet dated June 2022, included as part of this contract
- POST BID REVIEW CERTIFICATION: Dated 06-22-23, included as part of this contract

hereinafter called the project, for the sum of **TWO HUNDRED FIFTY-ONE MILLION TWO HUNDRED FIVE THOUSAND FIVE HUNDRED EIGHTY-EIGHT Dollars (\$251,205,588.)** and all extra work in connection therewith, under the terms as stated in the General and Special Conditions, if applicable, of the Contract Specifications, and at his (its or their) own proper cost and expense to furnish all the materials, supplies, machinery, equipment, tools, superintendent, labor, insurance, and other accessories and services necessary to complete the said project in accordance with the conditions and prices stated in the Proposal, the General Conditions, Special Conditions of the Contract Specifications, the plans, which include all maps, plats, blue prints, and other drawings and printed or written explanatory matter thereof, the specifications and contract documents therefore as prepared by **AECOM Technical Services, Inc.**, herein entitled the Architect/Engineer, all of which are made a part hereof and collectively evidence and constitute the contract.

The contractor hereby agrees to commence work under this contract on **(See Notice to Proceed)** and to fully complete the project within **1,440** consecutive calendar days thereafter. This is of the essence for the completion of this contract. The contractor further agrees to pay, as liquidated damages, the sum of **\$5,000.00** for each consecutive calendar day thereafter as hereinafter provided in Article 7.5 of the General Conditions.

The OWNER agrees to pay the CONTRACTOR in current funds for the performance of the contract, subject to additions and deductions, as provided in the General Conditions of the Contract Specification, and to make payments on account thereof as provided in Article 10 of the General Conditions.

Only domestic materials shall be acquired or used for any public work unless the head of the department, or other public officer charged with the duty by law, shall determine it to be inconsistent with the public interest, or the cost to be unreasonable, or domestic materials of the class or kind to be used are not mined, produced or manufactured, as the case may be, in the United States in commercial quantities and of a satisfactory quality.

The Contractor shall conform to all provisions of "Law Against Discrimination" N.J.S.A. 10:5-31 et seq. and N.J.A.C. 17:27.

IN WITNESS WHEREOF, the parties to these presents have executed this contract in four (4) counterparts, each of which shall be deemed an original, in the year and day first above mentioned.

ATTEST:

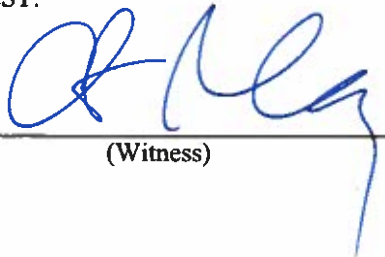

(Witness)

**DIVISION OF PROPERTY MANAGEMENT
AND CONSTRUCTION**

By 

RICHARD S. FLÓDMAND
DEPUTY DIRECTOR

(Title)

(Affix Corporate Seal)

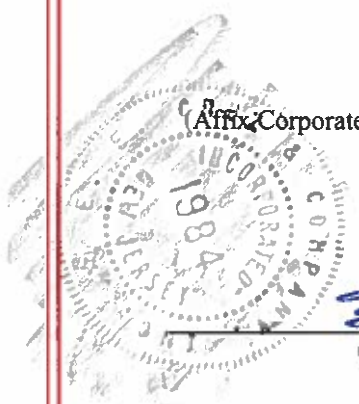



(Witness)

By _____
E.E. CRUZ & COMPANY, INC.
(Contractor)

PRESIDENT

(Title)

16-16 WHITESTONE EXPRESSWAY, 5TH
FLOOR
WHITESTONE, NY 11357

(Address)

WARRANTY:

It is hereby certified and warranted by the undersigned contractor and by the undersigned principals or officers thereof, for said Contractor and for themselves, personally and individually, that no person has been employed to solicit or secure this Contract in violation of the provisions of Section 10, Chapter 48 of the Laws of 1954, N.J.S.A. 52:34-15, or in violation of any other laws of the State of New Jersey; and it is further warranted that all applicable laws and regulations shall be complied within the performance of this contract.

Please be advised that pursuant to N.J.S.A. 54:49-19 et seq. and notwithstanding any provision of the law to the contrary, whenever any taxpayer, partnership or S corporation under contract to provide goods or services or construction projects to the State of New Jersey or its agencies or instrumentalities, including the legislative and judicial branches of State government, is entitled to payment for those goods or services at the same time the taxpayer, partner or shareholder of that entity is indebted for any State tax, the Director of the Division of Taxation shall seek to set off so much of that payment as shall be necessary to satisfy the indebtedness. The amount set-off shall not allow for the deduction of any expense or other deductions which might be attributable to the taxpayer, partner, or shareholder subject to set-off under this Act.

The Director of the Division of Taxation shall give notice of the set-off to the taxpayer, partner or shareholder and provide an opportunity for a hearing within 30 days of such notice under the procedures for protests established under N.J.S.A. 54:49-18. No request for conference, protest, or subsequent appeal to the Tax Court from any protest shall stay the collection of the indebtedness. Interest that may be payable by the State, pursuant to N.J.S.A. 52:32-32 et seq. to the taxpayer shall be stayed.

By signing this contract, I certify, pursuant to N.J.S.A. 52:34-12.2, that the entity for which I am authorized to bid:

has no ongoing business activities in Northern Ireland and does not maintain a physical presence therein through the operation of offices, plants, factories, or similar facilities, either directly or indirectly, through intermediaries, subsidiaries or affiliated companies over which it maintains effective control; or

will take lawful steps in good faith to conduct any business operations it has in Northern Ireland in accordance with the McBride principles of nondiscrimination in employment as set forth in N.J.S.A. 52:18A-89.5 and in conformance with the United Kingdom's Fair Employment (Northern Ireland) Act of 1989, and permit independent monitoring of their compliance with those principles.

I certify that the foregoing statements made by me are true. I am aware that if any of the foregoing statements made by me are willfully false, I am subject to punishment.

(Affix Corporate Seal)

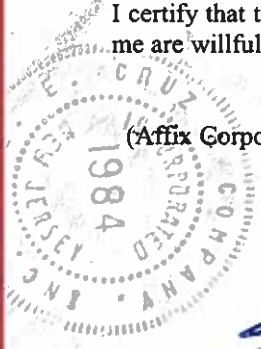



(Witness)

By

E.E. CRUZ & COMPANY, INC.

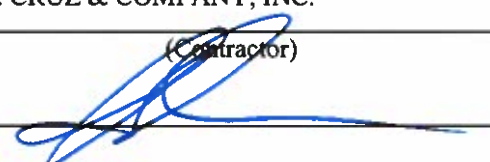
(Contractor)

PRESIDENT
(Title)
16-16 WHITESTONE EXPRESSWAY, 5TH
FLOOR
WHITESTONE, NY 11357

(Address)

This contract conforms to the standard form approved by the Attorney General.

**MATTHEW J. PLATKIN
ATTORNEY GENERAL OF NEW JERSEY**

* Current Wage Rates dated July 31, 2023 and are included as part of this contract.

“THE MINORITY PERCENTAGE GOAL REQUIREMENT FOR THIS CONTRACT IS 60% PER SKILLED CRAFT.”

“THE FEMALE PERCENTAGE GOAL REQUIREMENT FOR THIS CONTRACT IS 6.9% PER SKILLED CRAFT.”

“(The Contractor) shall maintain all documentation related to products, transactions or services under this contract for a period of five years from the date of final payment. Such records shall be made available to the New Jersey Office of the State Comptroller upon request.”

****Revised via Bulletin V****

BID PROPOSAL FORM

STATE OF NEW JERSEY
DEPARTMENT OF TREASURY
DIVISION OF PROPERTY MANAGEMENT & CONSTRUCTION
P O BOX 034
TRENTON NEW JERSEY 08625-0034

The bid proposal is to be returned in the pre-addressed envelope and will be accepted no later than 2:00 p.m.,
June 8, 2023 after which time the bid proposals will be publicly opened and read.

FIRM NAME:
(Please Type or Print)
(Business Street Address ONLY –
No P O Box)

E.E. Cruz & Company, Inc.
16-16 Whitestone Expressway, 5th Fl
Whitestone, NY 11357

PROJECT NO P1155-02 Re-Bid

PROJECT: Re-Build By Design – Resist Alignment, Hudson River Project

LOCATION: Hoboken, Weehawken and Jersey City, NJ

COUNTY: Hudson

The undersigned Specially Pre-Qualified Single Prime Contractor proposes to be responsible for all work shown in the contract plans and specifications and provide a unit cost sum bid, including allowances, for all materials, equipment, and labor to construct the **Hudson River Coastal Defense – Resist Alignment**, for the unit price total of:

Total of Base Bid \$
Items 1 through 42
from the attached
Unit Price List: **209,656,188.00**

(Numerical Figures Only)

In accordance with N.J.S.A. 52:35-1 et seq., the Contractor is classified with the Division of Property Management and Construction (DPMC) in one of the following trades: **Construction Manager as Constructor (C006) or General Construction (C008) or Site Work (C054)**

The proposal is based upon the bid documents listed below.

1. Instructions to Bidders and General Conditions dated revised June 2022
2. Specifications dated June 2022
3. Drawing(s)#: See Cover Sheet Dated June 2022

This project will be fully completed and ready for occupancy within 1,440 calendar days.

Liquidated damages will be assessed at \$5,000.00 per day.

The above price is good through sixty (60) days after the bid opening date.

Submit only one bid proposal and bid bond form.

PROJECT NO.: P1155-02 Re-Bid

A bid bond in the amount of ten percent (10%) of the TOTAL bid, including alternates if applicable, must accompany this proposal form.

The Contractor must submit a fully completed bid form with prices for all unit price items and allowances, otherwise the bid may be considered non-responsive.

Having examined the bid documents and the site of the proposed work and being familiar with all of the conditions surrounding the construction of the proposed project including the availability of materials and labor, the Contractor hereby proposes to furnish all labor, materials and supplies, and to construct the project as submitted, within the time set forth therein, and at the price stated. This price is to cover all expenses incurred in performing the work required, of which this proposal is a part.

The Contractor acknowledges and affirms that it has personal knowledge of or has obtained and reviewed a copy of the valid prevailing wage rates for all trades involved in the project for the geographical location of the project as issued by the Commissioner of the Department of Labor, P O Box 389, Trenton, New Jersey, 08625 (609) 292-2259.

The Contractor acknowledges receipt of the following Bulletins:

<u>BULLETIN NUMBER</u>	<u>DATE OF BULLETIN</u>
A	June 28, 2021
B	July 12, 2021
C	August 3, 2022
D	August 3, 2022
E	August 3, 2022
F	August 3, 2022
G	August 26, 2022
H	September 1, 2022
I	September 8, 2022
J	September 27, 2022
K	October 6, 2022
L	October 18, 2022
M	October 20, 2022
N	November 16, 2022
O	November 22, 2022
P	December 13, 2022
Q	December 20, 2022
R	January 5, 2023
S	January 26, 2023
T	February 23, 2023
U	April 18, 2023
V	May 25, 2023

Specially Pre-Qualified Sub-Contractors

The names and addresses of each Specially Pre-Qualified Subcontractor included in this Single Bid proposal are listed below and have been Specially Pre-Qualified for this project. The Contractor acknowledges the failure to list Specially Pre-Qualified Subcontractors in the section below as part of Single Bid proposals shall constitute a non-waivable material deviation resulting in a rejection of the bid.

SPECIALITY FLOOD GATES

NAME: Walz & Krezner, Inc.

ADDRESS: 91 Willenbrock Rd Ste B4, Oxford, CT 06478

SPECIALITY FLOOD GATES

NAME: Orange Flood Control, LLC

ADDRESS: 48 Bi State Plz, Old Tappan, NJ 07675

SPECIALITY FLOOD GATES

NAME: Rodney Hunt, Inc.

ADDRESS: 6200 Savoy Drive, Houston, TX 77036

URBAN PARK CONSTRUCTION

NAME: Kelco Construction, Inc.

ADDRESS: 25 Newton Pl, Hauppauge, NY 11788

DPMC Classified Sub-Contractors

The names and addresses of each Subcontractor included in this Single Bid proposal are listed below and are classified with DPMC in accordance with N.J.S.A. 52:35-1 et seq. at the time of the bid due date. If the Single Prime contractor intends to perform the work described under any of the listed trades sections of this bid proposal form, that Single Prime Contractor must be classified in that trade and listed in the appropriate Subcontractor section of this bid proposal. The Contractor acknowledges the failure to list classified Subcontractors as part of Single Bid proposals shall constitute a non-waivable material deviation resulting in a rejection of the bid.

STRUCTURAL STEEL & ORNAMENTAL IRON (C029)

NAME: Shepard Steel Co., Inc.

ADDRESS: 110 Meadow St, Hartford, CT 06114

PROJECT NO.: P1155-02 Re-Bid

PLUMBING (C030)

NAME: Cooper Plumbing and Mechanical LLC

ADDRESS: 40 Patterson Ave, Hamilton Square, NJ 08610

ELECTRICAL (C047)

NAME: Welsbach Electric Corp.

ADDRESS: 11101 14th Ave, College Point, NY 11356

UNIT PRICES

- A. Unit Prices, unless otherwise noted, are to include incidental work included in connection with the particular type of work involved and are to include, but not necessarily be limited to, the following:
1. Engineering, including calculations, detailing, coordination, and shop drawings.
 2. Material costs, including all allowances necessary for all gates, piping, utility connections, irrigation systems, lighting systems, etc.
 3. Labor, tools, and equipment.
 4. Necessary accessories, e.g., hangers, inserts, clips, bolts, painting, labeling, testing, etc.
 5. Fabrication and shop costs.
 6. Shop and field labor, including supervision and engineering layout costs.
 7. Temporary utilities required, all traffic control and detours including all necessary work and general public safety precautions.
 8. Costs of standby trades during or beyond normal working hours.
 9. Transportation, storage, hoisting, rigging, freight, taxes of any kind, fringe benefits, overhead and profit (excluding Insurance Cost).
 10. Operations and maintenance manual, training, testing, cleaning, balancing and controlled and certified special inspections.
 11. Overhead.
 12. Profit
- B. Provide unit prices based upon the specification standards and as noted herein. Unit prices shall apply to work when added and also to work when deleted, as indicated in the Bid Proposal Form, and applied as detailed in the Project specifications.

PROJECT NO.: P1155-02 Re-Bid

Contractor is to provide unit cost and total cost for each item listed below and as defined in Section 012901 – Measurement and Payment, for each item listed below. All unit costs shall be filled out in numbers and words, if there is a difference between the numbers and words, the written price shall govern.

<u>UNIT PRICES</u> <u>ITEM #</u>	<u>DESCRIPTION OF ITEM</u>	<u>BID ITEMS QUANTITY</u>	<u>TOTAL COST</u>
1	Mobilization/Demobilization See Specification Section 012901		
	Six Million Five Hundred Thousand Dollars	Per 1 LS	\$ 6,500,000.00
	Zero Cents		
	\$ 6,500,000.00		
2	Temporary Facilities Maintenance See Specification Section 012901		
	Thirty-Five Thousand Dollars	48 MO	\$ 1,680,000.00
	Zero Cents		
	\$ 35,000.00		
3A	Concrete Resist Structure Walls – Removals & Utility Work See Specification Section 012901		
	Eleven Million Seventy-Six Thousand Five Hundred Dollars	Per 1 LS	\$ 11,076,500.00
	Zero Cents		
	\$ 11,076,500.00		
3B	Concrete Resist Structure Walls – Restoration See Specification Section 012901		
	Eight Hundred Fifty Thousand Dollars	Per 1 LS	\$ 850,000.00
	Zero Cents		
	\$ 850,000.00		

PROJECT NO.: P1155-02 Re-Bid

3C	Concrete Resist Structure Walls – Concrete Wall See Specification Section 012901			
	Fifty Million Nine Hundred Eighty Thousand One Hundred Fifty Eight	Dollars	Per 1 LS	\$ 50,980,158.00
	Zero	Cents		
	\$ 50,980,158.00			
4A	Resist Structure Gate SG-1 and Appurtenances See Specification Section 012901			
	Five Hundred Thirty Thousand	Dollars	Per 1 LS	\$ 530,000.00
	Zero	Cents		
	\$ 530,000.00			
4B	Resist Structure Gate SG-2 and Appurtenances See Specification Section 012901			
	Three Hundred Eighty-Five Thousand	Dollars	Per 1 LS	\$ 385,000.00
	Zero	Cents		
	\$ 385,000.00			
4C	Resist Structure Gate SG-3 and Appurtenances See Specification Section 012901			
	Three Million Seventy-Eight Thousand	Dollars	Per 1 LS	\$ 3,078,000.00
	Zero	Cents		
	\$ 3,078,000.00			
4D	Resist Structure Gate SG-4 and Appurtenances See Specification Section 012901			
	One Million Seven Hundred Thousand	Dollars	Per 1 LS	\$ 1,700,000.00
	Zero	Cents		
	\$ 1,700,000.00			

PROJECT NO.: P1155-02 Re-Bid

4E	Resist Structure Gate SG-5 and Appurtenances See Specification Section 012901		
	One Million Six Hundred Forty Thousand Dollars	Per 1 LS	\$ 1,640,000.00
	Zero Cents		
	\$ 1,640,000.00		
4F	Resist Structure Gate SG-6 and Appurtenances See Specification Section 012901		
	Eight Hundred Eighty-Three Thousand Dollars	Per 1 LS	\$ 883,000.00
	Zero Cents		
	\$ 883,000.00		
4G	Resist Structure Gate SG-7 and Appurtenances See Specification Section 012901		
	Nine Hundred Ninety Thousand Dollars	Per 1 LS	\$ 990,000.00
	Zero Cents		
	\$ 990,000.00		
4H	Resist Structure Gate SG-8 and Appurtenances See Specification Section 012901		
	Seven Hundred Eighty-Five Thousand Dollars	Per 1 LS	\$ 785,000.00
	Zero Cents		
	\$ 785,000.00		

PROJECT NO.: P1155-02 Re-Bid

4I	Resist Structure Gate SG-9 and Appurtenances See Specification Section 012901		
	Seven Hundred Thirty-Seven Thousand Dollars	Per 1 LS	\$ 737,000.00
	Zero Cents		
	\$ 737,000.00		
4J	Resist Structure Gate SG-10 and Appurtenances See Specification Section 012901		
	One Hundred Thirty-Six Thousand Dollars	Per 1 LS	\$ 136,000.00
	Zero Cents		
	\$ 136,000.00		
4K	Resist Structure Gate SG-11 and Appurtenances See Specification Section 012901		
	Four Hundred Twenty Thousand Dollars	Per 1 LS	\$ 420,000.00
	Zero Cents		
	\$ 420,000.00		
4L	Resist Structure Gate SG-12 and Appurtenances See Specification Section 012901		
	One Million Two Hundred Fifty Thousand Dollars	Per 1 LS	\$ 1,250,000.00
	Zero Cents		
	\$ 1,250,000.00		
4M	Resist Structure Gate SG-13 and Appurtenances See Specification Section 012901		
	One Hundred Ninety-Four Thousand Dollars	Per 1 LS	\$ 194,000.00
	Zero Cents		
	\$ 194,000.00		

4N	Resist Structure Gate SSG-1 and Appurtenances See Specification Section 012901		
	<u>Eight Hundred Twenty Thousand Dollars</u>	<u>Per 1 LS</u>	<u>\$ 820,000.00</u>
	<u>Zero Cents</u>		
	<u>\$ 820,000.00</u>		
4O	Resist Structure Gate SSG-2 and Appurtenances See Specification Section 012901		
	<u>Six Hundred Fifty Thousand Dollars</u>	<u>Per 1 LS</u>	<u>\$ 650,000.00</u>
	<u>Zero Cents</u>		
	<u>\$ 650,000.00</u>		
4P	Resist Structure Gate SSG-3 and Appurtenances See Specification Section 012901		
	<u>Eight Hundred Forty-Five Thousand Dollars</u>	<u>Per 1 LS</u>	<u>\$ 845,000.00</u>
	<u>Zero Cents</u>		
	<u>\$ 845,000.00</u>		
4Q	Resist Structure Gate SSG-4 and Appurtenances See Specification Section 012901		
	<u>Six Hundred Forty Thousand Dollars</u>	<u>Per 1 LS</u>	<u>\$ 640,000.00</u>
	<u>Zero Cents</u>		
	<u>\$ 640,000.00</u>		

PROJECT NO.: P1155-02 Re-Bid

4R	Resist Structure Gate NG-1 and Appurtenances See Specification Section 012901			
	Ninety-One Thousand	Dollars	Per 1 LS	\$ 91,000.00
	Zero	Cents		
	\$ 91,000.00			
4S	Resist Structure Gate NG-2 and Appurtenances See Specification Section 012901			
	Eight Hundred Thousand	Dollars	Per 1 LS	\$ 800,000.00
	Zero	Cents		
	\$ 800,000.00			
4T	Resist Structure Gate NG-3 and Appurtenances See Specification Section 012901			
	Eighty-Six Thousand	Dollars	Per 1 LS	\$ 86,000.00
	Zero	Cents		
	\$ 86,000.00			
4U	Resist Structure Gate NG-5 and Appurtenances See Specification Section 012901			
	Seven Hundred Eighty-Six Thousand	Dollars	Per 1 LS	\$ 786,000.00
	Zero	Cents		
	\$ 786,000.00			

PROJECT NO.: P1155-02 Re-Bid

4V	Resist Structure Gate NG-6 and Appurtenances See Specification Section 012901		
	One Hundred Fifty-Six Thousand Dollars	Per 1 LS	\$ 156,000.00
	Zero Cents		
	\$ 156,000.00		
4W	Resist Structure Gate NG-7 and Appurtenances See Specification Section 012901		
	Five Million Five Hundred Thousand Dollars	Per 1 LS	\$ 5,500,000.00
	Zero Cents		
	\$ 5,500,000.00		
4X	Resist Structure Gate NG-8 and Appurtenances See Specification Section 012901		
	One Million One Hundred Thirteen Thousand Dollars	Per 1 LS	\$ 1,113,000.00
	Zero Cents		
	\$ 1,113,000.00		
4Y	Resist Structure Gate NG-9 and Appurtenances See Specification Section 012901		
	Nine Hundred Ten Thousand Dollars	Per 1 LS	\$ 910,000.00
	Zero Cents		
	\$ 910,000.00		

PROJECT NO.: P1155-02 Re-Bid

4Z	Resist Structure Gate NG-10 and Appurtenances See Specification Section 012901		
	Nine Hundred Sixty Thousand Dollars	Per 1 LS	\$ 960,000.00
	Zero Cents		
	\$ 960,000.00		
4AA	Resist Structure Gate NG-11 and Appurtenances See Specification Section 012901		
	Three Million Six Hundred Fifty Thousand Dollars	Per 1 LS	\$ 3,650,000.00
	Zero Cents		
	\$ 3,650,000.00		
4BB	Resist Structure Gate SG-3A and Appurtenances See Specification Section 012901		
	Five Hundred Thirty Thousand Dollars	Per 1 LS	\$ 530,000.00
	Zero Cents		
	\$ 530,000.00		
4CC	Resist Structure Sluice Gates (6), Steel Flap Gate, Steel Face Plate and Appurtenances See Specification Section 012901		
	Two Hundred Fifty Thousand Dollars	Per 1 LS	\$ 250,000.00
	Zero Cents		
	\$ 250,000.00		

PROJECT NO.: P1155-02 Re-Bid

5	Provide and Install H-Piles See Specification Section 012901			
	Two Hundred	Dollars	51,954 LF	\$ 10,390,800.00
	Zero	Cents		
	\$ 200.00			
6	Provide and Install Micro-piles, 9-5/8-inch diameter See Specification Section 012901			
	Four Hundred Seventy-Five	Dollars	57,138 LF	\$ 27,140,550.00
	Zero	Cents		
	\$ 475.00			
7	Provide and Install Micro-piles, 11-7/8- inch diameter See Specification Section 012901			
	Four Hundred Forty	Dollars	6,700 LF	\$ 2,948,000.00
	Zero	Cents		
	\$ 440.00			
8	Provide and Install Micro-piles, 13-3/8- inch diameter See Specification Section 012901			
	Four Hundred Fifty	Dollars	2,484 LF	\$ 1,117,800.00
	Zero	Cents		
	\$ 450.00			
9	Provide and Install Sheetpile Cutoff Walls PZ-22 See Specification Section 012901			
	One Hundred	Dollars	81,591 SF	\$ 8,159,100.00
	Zero	Cents		
	\$ 100.00			

PROJECT NO.: P1155-02 Re-Bid

10	Provide and Install Sheetpile I-Wall Support PZ-27 See Specification Section 012901 One Hundred Thirty	Dollars	2,888 SF	\$ 375,440.00
	Zero	Cents		
	\$ 130.00			
11	Install Jet Grouting See Specification Section 012901 Two Thousand One Hundred	Dollars	1,830 CY	\$ 3,843,000.00
	Zero	Cents		
	\$ 2,100.00			
12	Excess Soil Disposal – Contaminated/ Regulated Non-Hazardous See Specification Section 012901 One Hundred Fifty	Dollars	34,746 Ton	\$ 5,211,900.00
	Zero	Cents		
	\$ 150.00			
13	Excess Soil Disposal – Hazardous or TSCA Regulated See Specification Section 012901 Three Hundred Ninty	Dollars	3,861 Ton	\$ 1,505,790.00
	Zero	Cents		
	\$ 390.00			
14	Additional Excavation – If and Where Directed See Specification Section 012901 One Hundred Twenty	Dollars	1,000 CY	\$ 120,000.00
	Zero	Cents		
	\$ 120.00			

PROJECT NO.: P1155-02 Re-Bid

15	Additional Excavation – Rock / Concrete, If and Where Directed See Specification Section 012901 Seven Hundred	Dollars	1,750 CY	\$ 1,225,000.00
	Zero	Cents		
	\$ 700.00			
16	Structural Backfill – If and Where Directed See Specification Section 012901 Ninty-One	Dollars	1,550 Tons	\$ 141,050.00
	Zero	Cents		
	\$ 91.00			
17	Roadway Base Course, DGA See Specification Section 012901 Eighty	Dollars	5,195 Tons	\$ 415,600.00
	Zero	Cents		
	\$ 80.00			
18	Roadway Base Course, Hot Mix Asphalt See Specification Section 012901 Two Hundred	Dollars	1,225 Tons	\$ 245,000.00
	Zero	Cents		
	\$ 200.00			
19	Roadway Top Course, Hot Mix Asphalt See Specification Section 012901 Three Hundred	Dollars	1,445 Tons	\$ 433,500.00
	Zero	Cents		
	\$ 300.00			

PROJECT NO.: P1155-02 Re-Bid

20	Replace Concrete Curb See Specification Section 012901		
	One Thousand Four Hundred Seventy-Five Dollars	350 CY	\$ 516,250.00
	Zero Cents		
	\$ 1,475.00		
21	Replace Concrete Sidewalk See Specification Section 012901		
	One Thousand Three Hundred Fifty Dollars	500 CY	\$ 675,000.00
	Zero Cents		
	\$ 1,350.00		
22	Replace Concrete Driveway See Specification Section 012901		
	Eight Hundred Sixty Dollars	250 CY	\$ 215,000.00
	Zero Cents		
	\$ 860.00		
23	Replace Asphalt Bikeway/Walkway See Specification Section 012901		
	Two Hundred Fifty Dollars	250 Tons	\$ 62,500.00
	Zero Cents		
	\$ 250.00		
24	Utility Relocation, If and Where Directed See Specification Section 012901		
	Four Million Five Hundred Thousand Dollars	ALLOWANCE	\$4,500,000.00
	Zero Cents		
	\$4,500,000.00		

PROJECT NO.: P1155-02 Re-Bid

25	Uniformed Traffic Directors, If and Where Directed See Specification Section 012901			
	Three Million One Hundred Thousand Dollars		ALLOWANCE	\$3,100,000.00
	Zero Cents			
	\$3,100,000.00			
26	Misc. Concrete, If and Where Directed See Specification Section 012901			
	Nine Hundred Dollars	300 CY		\$ 270,000.00
	Cents			
	\$ 900.00			
27	Sheeting Left in Place, If and Where Directed See Specification Section 012901			
	Five Dollars	7,650 SF		\$ 38,250.00
	Zero Cents			
	\$ 5.00			
28	Type 57 Clean Stone, If and Where Directed See Specification Section 012901			
	One Hundred Eighty Dollars	500 CY		\$ 90,000.00
	Zero Cents			
	\$ 180.00			
29	Subsurface Utility Explorations (SUE) See Specification Section 012901			
	One Thousand Dollars	180 EA		\$ 180,000.00
	Zero Cents			
	\$ 1,000.00			

PROJECT NO.: P1155-02 Re-Bid

30	Microtunnel for NHSA Outfall See Specification Section 012901			
	N/A	Dollars	Per 1 LS	N/A
	N/A	Cents		
	\$ N/A			
31	Urban Amenities See Specification Section 012901			
	Five Million Two Hundred Thousand	Dollars	Per 1 LS	\$ 5,200,000.00
	Zero	Cents		
	\$ 5,200,000.00			
32	Cove Park Improvement Option A (Base Park) See Specification Section 012901			
	Ten Million Five Hundred Thousand	Dollars	Per 1 LS	\$ 10,500,000.00
	Zero	Cents		
	\$ 10,500,000.00			
33	Controlled Low Strength Material (CLSM) – If and Where Directed See Specification Section 012901			
	Three Hundred Twenty	Dollars	500 CY	\$160,000.00
	Zero	Cents		
	\$ 320.00			
34	Nighttime Work, If and When Directed See Specification Section 012901			
	One Million Five Hundred Thousand	Dollars	ALLOWANCE	\$1,500,000.00
	Zero	Cents		
	\$1,500,000.00			

PROJECT NO.: P1155-02 Re-Bid

35	Excavation of Test Pits, If and Where Directed See Specification Section 012901			
	One Thousand Dollars	1,600 CY	\$ 1,600,000.00	
	Zero Cents			
	\$ 1,000.00			
36	Excavation of Test Pits, Archeological Investigation See Specification Section 012901			
	Seven Hundred Fifty Dollars	300 CY	\$ 225,000.00	
	Zero Cents			
	\$ 750.00			
37	Maintenance and Protection of Traffic See Specification Section 012901			
	Fifty Thousand Dollars	48 MO	\$ 2,400,000.00	
	Zero Cents			
	\$ 50,000.00			
38	Air, Noise, Dust, Vibration and Settlement Monitoring See Specification Section 012901			
	Two Million Five Hundred Thousand Dollars	Per 1 LS	\$ 2,500,000.00	
	Zero Cents			
	\$ 2,500,000.00			

PROJECT NO.: P1155-02 Re-Bid

39	Electrical Work See Specification Section 012901			
39A	Electrical Work – Resist Structure			
	One Million Five Hundred Fifty Thousand Dollars		Per 1 LS	\$ 1,550,000.00
	Zero Cents			
	\$ 1,550,000.00			
39B	Electrical Work – Urban Amenities			
	Three Million Six Hundred Thousand Dollars		Per 1 LS	\$ 3,600,000.00
	Zero Cents			
	\$ 3,600,000.00			
39C	Electrical Work – Gates			
	One Million Eight Hundred Thousand Dollars		Per 1 LS	\$ 1,800,000.00
	Zero Cents			
	\$ 1,800,000.00			
40	Gravel, If and Where Directed See Specification Section 012901			
	Two Hundred Dollars		500 CY	\$ 100,000.00
	Zero Cents			
	\$ 200.00			
41	Brick, Cobblestone, and Paver Sidewalks, Pavement, and Driveways See Specification Section 012901			
	One Thousand Dollars		2,500 SY	\$ 2,500,000.00
	Zero Cents			
	\$ 1,000.00			

PROJECT NO.: P1155-02 Re-Bid

42 New Jersey Transit Force Account
See Specification Section 012901

One Million Five Hundred Thousand
Dollars

ALLOWANCE

\$1,500,000.00

Zero Cents

\$1,500,000.00

If the unit prices are left blank, the bid will be deemed non-responsive.

ALTERNATE PRICING SCHEDULE

ALTERNATE PROPOSALS: ADDITIVE

Alternate Cove Park Improvement Option B (Full
No. 1 Park) - See Specification Section 012901

Forty One Million Five Hundred Forty-Nine Thousand
Four Hundred Dollars

Per 1 LS

\$ 41,549,400.00

Zero Cents

\$ 41,549,400.00

NOTE: If the alternate prices are left blank, the bid will be deemed non-responsive and will not be considered. The bidders shall enter a dollar amount, "0" or "No Change".

PROJECT NO.: P1155-02 Re-Bid

EXECUTION OF CONTRACT

Upon receipt of written notice of the acceptance of this bid, the Contractor shall execute the formal contract within 10 calendar days and deliver a Performance and Payment Bond as well as other information as required in the bid solicitation.

COMMENCEMENT OF WORK

Contractor acknowledges that the work is to commence upon receipt of the Notice to Proceed with the exception of permit activities.

BID SECURITY

Bid Bond is ten percent (10%) of the TOTAL bid, including alternates if applicable, and is to become the property of the State in the event the contract and bond are not executed within the time set forth as described in Section 6.4 of the Instructions to Bidders.

PROJECT NO.: P1155-02 Re-Bid

CERTIFICATION

I certify that the below named firm is classified by the Division of Property Management and Construction in the approved amount of \$ Unlimited for (trade) C054-Site Work until 8/02/2023 (expiration date).

I further certify that this firm's bid for this project does not cause the firm to exceed its aggregate rating limit, including consideration of uncompleted construction work (please refer to N.J.A.C. 17:19-2.13, which describes how certain major trade subcontract work is discounted 85% for purposes of calculating whether a contractor is within its rating).

Respectfully submitted,

(Seal-if Bid proposal is by a corporation)

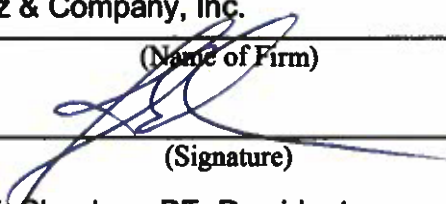
By: E.E. Cruz & Company, Inc.
(Name of Firm)

(Signature)
Joseph F. Sheehan, PE, President
(Title)
16-16 Whitestone Expressway, 5th FL
(Business Street Address ONLY – No P O Box)
Whitestone, NY, Queens, 11357
(City State County Zip)
Phone No. 212-431-3993
Fax No. 212-431-3996

Federal Identification No. [REDACTED]

Any change in ownership information since filing your Request for Classification (Form DPMC 27)

Yes

No

If yes, attach explanation.



State of New Jersey

DEPARTMENT OF TREASURY
DIVISION OF PROPERTY MANAGEMENT & CONSTRUCTION
P O Box 034
TRENTON NJ 08625-0034

PHILIP D. MURPHY
Governor

SHEILA Y. OLIVER
Lt. Governor

ELIZABETH MAHER MUOIO
State Treasurer

CHRISTOPHER CHIANESE
Director

June 28, 2021

SUBJECT: Bulletin "A" Dated June 28, 2021
PROJECT #: P1155-02
DESCRIPTION: Re-Build by Design Hudson River Project
Coastal Defense – Resist Alignment
Hoboken, Hudson County, NJ

To Whom It May Concern:

WE ARE FORWARDING A COPY OF THE ABOVE REFERENCED BULLETIN. PLEASE ACKNOWLEDGE RECEIPT BY RETURNING THIS FORM TO:

Division of Property Management and Construction
Attention: C. Geary
Contracts & Procurement
PO Box 034
Trenton NJ 08625-0034
Fax #: 609-777-1970

Sincerely,

Christopher R. Geary

Christopher R. Geary
Assistant Deputy Director
Contracts and Procurement

6/28/2021

Date Received

E.E. Cruz & Company, Inc

Firm Name

16-16 Whitestone Expressway, 5th FL, Whitestone, NY, 11357

Address

Joseph F. Sheehan
Signature

Joseph F. Sheehan, PE, President

Title



State of New Jersey

DEPARTMENT OF TREASURY
DIVISION OF PROPERTY MANAGEMENT & CONSTRUCTION
P O Box 034
TRENTON NJ 08625-0034

PHILIP D. MURPHY
Governor

SHEILA Y. OLIVER
Lt. Governor

ELIZABETH MAHER MUOIO
State Treasurer

CHRISTOPHER CHIANESE
Director

July 12, 2021

SUBJECT: Bulletin "B" Dated July 12, 2021
PROJECT #: P1155-02
DESCRIPTION: Re-Build by Design Hudson River Project
Coastal Defense – Resist Alignment
Hoboken, Hudson County, NJ

To Whom It May Concern:

WE ARE FORWARDING A COPY OF THE ABOVE REFERENCED BULLETIN. PLEASE ACKNOWLEDGE RECEIPT BY RETURNING THIS FORM TO:

By Email: christopher.geary@treas.nj.gov or

By Mail: Division of Property Management and Construction
Attention: C. Geary
Contracts & Procurement
DPMC, PO Box 034
Trenton NJ 08625-0034 or

By Fax: 609-777-1970

Sincerely,

Christopher R. Geary
Assistant Deputy Director
Contracts and Procurement

7/12/2021

Date Received

E.E. Cruz & Company, Inc

Firm Name

16-16 Whitestone Expressway, 5th FL, Whitestone, NY, 11357

Address

Signature

Joseph F. Sheehan, PE, President

Title

Project #P1155-02
Bulletin C

STATE OF NEW JERSEY DEPARTMENT OF TREASURY
DIVISION OF PROPERTY MANAGEMENT AND CONSTRUCTION
PO BOX 034, TRENTON, NJ 08625-0034

PROJECT#: P1155-02
Re-Build by Design Hudson River Project
Coastal Defense – Resist Alignment
Hoboken, Hudson County, NJ

A/E: AECOM

DATE: August 3, 2022

8/3/2022

Date Received

E.E. Cruz & Company, Inc

Firm Name

16-16 Whitestone Expressway, 5th FL, Whitestone, NY, 11357

Address

Signature

Joseph F. Sheehan, PE, President

Title

BULLETIN C

Bidder must acknowledge receipt of this Bulletin on bid form in the space provided therefor.

This Bulletin is issued for the purpose of amending certain requirements of the original Contract Documents, as noted hereinafter, and is hereby made part of and incorporated in full force as part of the Contract Documents. Unless specifically noted or specified hereinafter, all work shall comply with the applicable provisions of the Contract Documents.

A) NOTICE OF EXECUTIVE ORDER 125 REQUIREMENT

<http://nj.gov/comptroller/sandytransparency/contracts/sandy/>.

The contract resulting from this RFQ/RFP is subject to the requirements of Executive Order No. 125. Accordingly, the OSC will post a copy of the contract, including the RFQ/RFP, the winning bidder's proposal and other related contract documents for the above contract on the Sandy Transparency website.

In submitting its proposal, a bidder may designate specific information as not subject to disclosure. However, such bidder must have a good faith legal and/ or factual basis to assert that such designated portions of its proposal (i) are proprietary and confidential financial or commercial information or trade secrets or (ii) must not be disclosed to protect the personal privacy of an identified individual. The location in the proposal of any such designation should be clearly stated in a cover letter, and a redacted copy of the proposal should be provided.

The State reserves the right to make the determination as to what is proprietary or confidential, and will advise the winning bidder accordingly. The State will not honor any attempt by a winning bidder to designate its entire proposal as proprietary, confidential and/or to claim copyright protection for its entire proposal. In the event of any challenge to the winning bidder's assertion of confidentiality with which the State does not concur, the bidder shall be solely responsible for defending its designation.

B) REVISIONS TO PROJECT REQUIREMENTS

1. All businesses engaged in construction projects in the State must adopt policies that include, at a minimum, the requirements as per all Executive Orders, NJDOH and CDC recommendations regarding COVID. Please see the attached DPMC Notice dated March 9, 2022 to All Contractors and Project Personnel on DPMC Construction Projects.

STATE OF NEW JERSEY
DEPARTMENT OF TREASURY
DIVISION OF PROPERTY MANAGEMENT AND CONSTRUCTION
PO BOX 034, TRENTON, NJ 08625-0034

PROJECT #: P1155-02

A/E: AECOM

DATE: August 3, 2022

8/3/2022

Date Received

E.E. Cruz & Company, Inc

Firm Name

16-16 Whitestone Expressway, 5th FL, Whitestone, NY, 11357

Address

Signature

Joseph F. Sheehan, PE, President

Title

BULLETIN "D" - SBE

Bidder must acknowledge receipt of this Bulletin on bid form in the space provided therefore.

This Bulletin is issued for the purpose of amending certain requirements of the original Contract Documents, as noted hereinafter, and is hereby made part of and incorporated in full force as part of the Contract Documents. Unless specifically noted or specified hereinafter, all work shall comply with the applicable provisions of the Contract Documents.

1. SMALL BUSINESS ENTERPRISE GOALS

The Prime Contractor shall take all necessary and reasonable steps to ensure that Small Business Enterprises (SBE's), as defined in N.J.A.C. 17:13-1.2 have the maximum opportunity to compete for and perform contracts.

A. GOALS FOR THIS CONTRACT

1. Except as provided in this Bulletin, this contract includes a goal of awarding twenty-five (25) percent of the total contract value to Subcontractors that qualify as small businesses as defined in N.J.A.C. 17:13-2.1 and small businesses with revenues that do not exceed the annual revenue standards established by the Federal standard at 13 C.F.R. 121.201.
2. Only SBE's properly certified in accordance with A. 1 above by the date of bid with the Division of Revenue and Enterprise Services will be considered in determining whether the Contractor has met the Contract ~~set-aside~~ goals.
3. A database of certified SBE firms is available for review from the Division of Revenue and Enterprise Services (Telephone: 609-292-2146. Website: www.state.nj.us/njbusiness/contracting). This database is to be used as a source of information only, and does not relieve the Prime Contractor of the responsibility of seeking out other SBE's.

Revised June 2022

Project #P1155-02
Bulletin E

STATE OF NEW JERSEY DEPARTMENT OF TREASURY
DIVISION OF PROPERTY MANAGEMENT AND CONSTRUCTION
PO BOX 034, TRENTON, NJ 08625-0034

PROJECT#: P1155-02
Re-Build by Design Hudson River Project
Coastal Defense – Resist Alignment
Hoboken, Hudson County, NJ

A/E: AECOM

DATE: August 3, 2022

8/3/2022

Date Received

E.E. Cruz & Company, Inc

Firm Name

16-16 Whitestone Expressway, 5th FL, Whitestone, NY, 11357

Address

Signature

Joseph F. Sheehan, PE, President

Title

BULLETIN E

Bidder must acknowledge receipt of this Bulletin on bid form in the space provided therefor.

This Bulletin is issued for the purpose of amending certain requirements of the original Contract Documents, as noted hereinafter, and is hereby made part of and incorporated in full force as part of the Contract Documents. Unless specifically noted or specified hereinafter, all work shall comply with the applicable provisions of the Contract Documents.

A) REVISIONS TO SPECIFICATIONS

PART II: TECHNICAL CONTRACT SECTIONS

Division 01 – General Requirements

SECTION 011100 – SUMMARY OF WORK

1.03 SUMMARY

DELETE THE FOLLOWING:

In paragraph 1.03 A.1. in the second paragraph first sentence delete, “steel sheet pile cutoff walls”

REPLACE WITH THE FOLLOWING:

“steel sheet pile and grout cutoff walls”

DELETE THE FOLLOWING:

Paragraphs 1.03 A.3. c., d., and e. in their entirety.

REPLACE WITH THE FOLLOWING:

- c. Approximately 51,954 lf of H-Piles.
- d. Approximately 66,322 lf of Micropiles.
- e. Approximately 81,591 sf of steel sheet piles.”

1.05 WORK COVERED BY CONTRACT DOCUMENTS

ADD THE FOLLOWING:

After paragraph 1.05 B.1., add

Project #P1155-02
Bulletin F

STATE OF NEW JERSEY DEPARTMENT OF TREASURY
DIVISION OF PROPERTY MANAGEMENT AND CONSTRUCTION
PO BOX 034, TRENTON, NJ 08625-0034

8/3/2022

Date Received

E.E. Cruz & Company, Inc

Firm Name

16-16 Whitestone Expressway, 5th FL, Whitestone, NY, 11357

Address

Signature

Joseph F. Sheehan, PE, President

Title

PROJECT#: P1155-02
Re-Build by Design Hudson River Project
Coastal Defense – Resist Alignment
Hoboken, Hudson County, NJ

A/E: AECOM

DATE: August 3, 2022

BULLETIN F

Bidder must acknowledge receipt of this Bulletin on bid form in the space provided therefor.

This Bulletin is issued for the purpose of amending certain requirements of the original Contract Documents, as noted hereinafter, and is hereby made part of and incorporated in full force as part of the Contract Documents. Unless specifically noted or specified hereinafter, all work shall comply with the applicable provisions of the Contract Documents.

A) REVISED INSTRUCTIONS TO BIDDERS AND GENERAL CONDITIONS

1. Attached to this Bulletin is the Instructions to Bidders and General Conditions for Hudson River Coastal Defense – Resist Alignment Re-Build by Design dated Revised June 2022 for Contractor use.
 - a. Within Article 13.4, Insurance; revisions to 13.4.1 Insurance to Be Carried By The Contractor are illustrated in red below:

13.4.1 Insurance To Be Carried By The Contractor:

The Contractor shall obtain and maintain, **and cause its subcontractors to obtain and maintain**, at its expense and for the duration of the contract, minimum insurance coverage set forth below. By requiring such minimum insurance, the State of New Jersey shall not be deemed or construed to have assessed the risk that may be applicable to the Contractor under this contract. The Contractor shall assess its own risks and if it deems appropriate and/or prudent, maintain higher limits and/or broader coverage. The Contractor is not relieved of any liability or other obligations assumed or pursuant to the Contract by reason of its failure to obtain or maintain insurance in sufficient amounts, duration or types.

a Commercial General Liability:

(1) Commercial General Liability (CGL)-ISO occurrence form CG001 or a substitute form providing a minimum coverage of \$2,000,000 per occurrence for bodily injury liability and \$2,000,000 per occurrence for property damage liability and shall cover liability arising from:

- Premises/Operations
- Independent Contractors
- Products/Completed Operations
- Personal and Advertising Injury



State of New Jersey

DEPARTMENT OF TREASURY
DIVISION OF PROPERTY MANAGEMENT & CONSTRUCTION
P O BOX 034
TRENTON NJ 08625-0034

PHILIP D. MURPHY
Governor

SHEILA Y. OLIVER
Lt. Governor

ELIZABETH MAHER MUOIO
State Treasurer

CHRISTOPHER CHIANESE
Director

August 26, 2022

SUBJECT: Bulletin "G" Dated August 26, 2022
PROJECT #: Project #P1155-02
DESCRIPTION: Re-Build by Design
Coastal Defense -- Resist Alignment
Hoboken, Hudson County, NJ

To Whom It May Concern:

WE ARE FORWARDING A COPY OF THE ABOVE REFERENCED BULLETIN. PLEASE
ACKNOWLEDGE RECEIPT BY RETURNING THIS FORM TO:

By Email: shawn.taylor@treas.nj.gov or

By Mail: Division of Property Management and Construction
Attention: S. Taylor
Contracts & Procurement
DPMC, PO Box 034
Trenton NJ 08625-0034 or

By Fax: 609-777-1970

Sincerely,

Christopher R. Geary

Christopher R. Geary
Assistant Deputy Director
Contracts and Procurement

8/26/2022
Date Received

E.E. Cruz & Company, Inc.
Firm Name

16-16 Whitestone Expressway, 5th FL, Whitestone, NY, 11357
Address

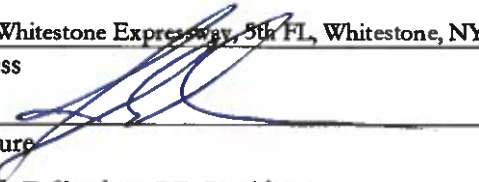
Signature
Joseph F. Sheehan, PE, President
Title



State of New Jersey

DEPARTMENT OF TREASURY
DIVISION OF PROPERTY MANAGEMENT & CONSTRUCTION
P O BOX 034
TRENTON NJ 08625-0034

PHILIP D. MURPHY
Governor

SHEILA Y. OLIVER
Lt. Governor

ELIZABETH MAHER MUOIO
State Treasurer

CHRISTOPHER CHIANESE
Director

September 1, 2022

SUBJECT: Bulletin "H" Dated September 1, 2022
PROJECT #: Project #P1155-02
DESCRIPTION: Re-Build by Design
Coastal Defense – Resist Alignment
Hoboken, Hudson County, NJ

To Whom It May Concern:

WE ARE FORWARDING A COPY OF THE ABOVE REFERENCED BULLETIN. PLEASE ACKNOWLEDGE RECEIPT BY RETURNING THIS FORM TO:

By Email: shawn.taylor@treas.nj.gov or

By Mail: Division of Property Management and Construction
Attention: S. Taylor
Contracts & Procurement
DPMC, PO Box 034
Trenton NJ 08625-0034 or

By Fax: 609-777-1970

Sincerely,

Christopher R. Geary
Assistant Deputy Director
Contracts and Procurement

9/1/2022

Date Received

E.E. Cruz & Company, Inc

Firm Name

16-16 Whitestone Expressway 8th FL, Whitestone, NY, 11357

Address

Joseph F. Sheehan, PE, President

Title



State of New Jersey

DEPARTMENT OF TREASURY
DIVISION OF PROPERTY MANAGEMENT & CONSTRUCTION
P O BOX 034
TRENTON NJ 08625-0034

PHILIP D. MURPHY
Governor

SHEILA Y. OLIVER
Lt. Governor

ELIZABETH MAHER MUOIO
State Treasurer

CHRISTOPHER CHIANESE
Director

September 8, 2022

SUBJECT: **Bulletin "I" Dated September 8, 2022**
PROJECT #: **Project #P1155-02**
DESCRIPTION: **Re-Build by Design
Coastal Defense – Resist Alignment
Hoboken, Hudson County, NJ**

To Whom It May Concern:

WE ARE FORWARDING A COPY OF THE ABOVE REFERENCED BULLETIN. PLEASE ACKNOWLEDGE RECEIPT BY RETURNING THIS FORM TO:

By Email: shawn.taylor@treas.nj.gov or

By Mail: Division of Property Management and Construction
Attention: S. Taylor
Contracts & Procurement
DPMC, PO Box 034
Trenton NJ 08625-0034 or

By Fax: 609-777-1970

Sincerely,
Christopher R. Geary
Christopher R. Geary
Assistant Deputy Director
Contracts and Procurement

9/8/2022
Date Received
E.E. Cruz & Company, Inc
Firm Name
16-16 Whitestone Expressway, 5th FL, Whitestone, NY, 11357
Address

Joseph F. Sheehan, PE, President
Title



State of New Jersey

DEPARTMENT OF TREASURY
DIVISION OF PROPERTY MANAGEMENT & CONSTRUCTION
P O Box 034
TRENTON NJ 08625-0034

PHILIP D. MURPHY
Governor

SHEILA Y. OLIVER
Lt. Governor

ELIZABETH MAHER MUOIO
State Treasurer

CHRISTOPHER CHIANESE
Director

September 27, 2022

SUBJECT: Bulletin "J" Dated September 27, 2022
PROJECT #: Project #P1155-02
DESCRIPTION: Re-Build by Design
Coastal Defense – Resist Alignment
Hoboken, Hudson County, NJ

To Whom It May Concern:

WE ARE FORWARDING A COPY OF THE ABOVE REFERENCED BULLETIN. PLEASE ACKNOWLEDGE RECEIPT BY RETURNING THIS FORM TO:

By Email: shawn.taylor@treas.nj.gov or

By Mail: Division of Property Management and Construction
Attention: S. Taylor
Contracts & Procurement
DPMC, PO Box 034
Trenton NJ 08625-0034 or

By Fax: 609-777-1970

Sincerely,
Christopher R. Geary
Christopher R. Geary
Assistant Deputy Director
Contracts and Procurement

9/27/2022
Date Received
E.E. Cruz & Company, Inc.
Firm Name
16-16 Whitestone Expressway, 5th FL, Whitestone, NY 11357
Address

Signature
Joseph F. Sheehan, PE, President
Title



State of New Jersey

DEPARTMENT OF TREASURY
DIVISION OF PROPERTY MANAGEMENT & CONSTRUCTION
P O BOX 034
TRENTON NJ 08625-0034

PHILIP D. MURPHY
Governor

SHEILA Y. OLIVER
Lt. Governor

ELIZABETH MAHER MUOIO
State Treasurer

CHRISTOPHER CHIANESE
Director

October 6, 2022

SUBJECT: Bulletin "K" Dated October 6, 2022
PROJECT #: Project #P1155-02
DESCRIPTION: Re-Build by Design
Coastal Defense -- Resist Alignment
Hoboken, Hudson County, NJ

To Whom It May Concern:

WE ARE FORWARDING A COPY OF THE ABOVE REFERENCED BULLETIN. PLEASE ACKNOWLEDGE RECEIPT BY RETURNING THIS FORM TO:

By Email: shawn.taylor@treas.nj.gov or

By Mail: Division of Property Management and Construction
Attention: S. Taylor
Contracts & Procurement
DPMC, PO Box 034
Trenton NJ 08625-0034 or

By Fax: 609-777-1970

Sincerely,
Christopher R. Geary
Christopher R. Geary
Assistant Deputy Director
Contracts and Procurement

10/6/2022
Date Received
E.E. Cruz & Company, Inc.
Firm Name
16-16 Whitestone Expressway, 5th FL, Whitestone, NY 11357
Address

Signature
Joseph F. Sheehan, PE, President
Title



State of New Jersey

DEPARTMENT OF TREASURY
DIVISION OF PROPERTY MANAGEMENT & CONSTRUCTION
P O BOX 034
TRENTON NJ 08625-0034

PHILIP D. MURPHY
Governor

SHEILA Y. OLIVER
Lt. Governor

ELIZABETH MAHER MUOIO
State Treasurer

CHRISTOPHER CHIANESE
Director

October 18, 2022

SUBJECT: Bulletin "L" Dated October 18, 2022
PROJECT #: Project #P1155-02
DESCRIPTION: Re-Build by Design
Coastal Defense - Resist Alignment
Hoboken, Hudson County, NJ

To Whom It May Concern:

WE ARE FORWARDING A COPY OF THE ABOVE REFERENCED BULLETIN. PLEASE ACKNOWLEDGE RECEIPT BY RETURNING THIS FORM TO:

By Email: shawn.taylor@treas.nj.gov or

By Mail: Division of Property Management and Construction
Attention: S. Taylor
Contracts & Procurement
DPMC, PO Box 034
Trenton NJ 08625-0034 or

By Fax: 609-777-1970

Sincerely,

Christopher R. Geary
Christopher R. Geary
Assistant Deputy Director
Contracts and Procurement

10/18/2022
Date Received
E.E. Cruz & Company, Inc.
Firm Name
16-16 Whitestone Expressway, 5th FL, Whitestone, NY 11357
Address
Signature
Joseph F. Sheehan, PE, President
Title



State of New Jersey

DEPARTMENT OF TREASURY
DIVISION OF PROPERTY MANAGEMENT & CONSTRUCTION
P O BOX 034
TRENTON NJ 08625-0034

PHILIP D. MURPHY
Governor

SHEILA Y. OLIVER
Lt. Governor

ELIZABETH MAHER MUOIO
State Treasurer

CHRISTOPHER CHIANESE
Director

October 20, 2022

SUBJECT: Bulletin "M" Dated October 20, 2022
PROJECT #: Project #P1155-02
DESCRIPTION: Re-Build by Design
Coastal Defense – Resist Alignment
Hoboken, Hudson County, NJ

To Whom It May Concern:

WE ARE FORWARDING A COPY OF THE ABOVE REFERENCED BULLETIN. PLEASE ACKNOWLEDGE RECEIPT BY RETURNING THIS FORM TO:

By Email: shawn.taylor@treas.nj.gov or

By Mail: Division of Property Management and Construction
Attention: S. Taylor
Contracts & Procurement
DPMC, PO Box 034
Trenton NJ 08625-0034 or

By Fax: 609-777-1970

Sincerely,
Christopher R. Geary
Christopher R. Geary
Assistant Deputy Director
Contracts and Procurement

10/20/2022
Date Received

E.E. Cruz & Company, Inc.
Firm Name

16-16 Whitestone Expressway, 5th FL, Whitestone, NY 11357
Address

[Signature]
Signature
Joseph F. Sheehan, PE, President
Title



State of New Jersey

DEPARTMENT OF TREASURY
DIVISION OF PROPERTY MANAGEMENT & CONSTRUCTION
P O BOX 034
TRENTON NJ 08625-0034

PHILIP D. MURPHY
Governor

SHEILA Y. OLIVER
Lt. Governor

ELIZABETH MAHER MUOJO
State Treasurer

CHRISTOPHER CHIANESE
Director

November 16, 2022

SUBJECT: Bulletin "N" Dated November 16, 2022
PROJECT #: Project #P1155-02
DESCRIPTION: Re-Build by Design
Coastal Defense – Resist Alignment
Hoboken, Hudson County, NJ

To Whom It May Concern:

WE ARE FORWARDING A COPY OF THE ABOVE REFERENCED BULLETIN. PLEASE ACKNOWLEDGE RECEIPT BY RETURNING THIS FORM TO:

By Email: shawn.taylor@treas.nj.gov or

By Mail: Division of Property Management and Construction
Attention: S. Taylor
Contracts & Procurement
DPMC, PO Box 034
Trenton NJ 08625-0034 or

By Fax: 609-777-1970

Sincerely,
Christopher R. Geary
Christopher R. Geary
Assistant Deputy Director
Contracts and Procurement

9/16/2022
Date Received
E.E. Cruz & Company, Inc.
Firm Name
16-16 Whitestone Expressway, 5th FL, Whitestone, NY 11357
Address

Signature
Joseph F. Sheehan, PE, President
Title



State of New Jersey

DEPARTMENT OF TREASURY
DIVISION OF PROPERTY MANAGEMENT & CONSTRUCTION
P O BOX 034
TRENTON NJ 08625-0034

PHILIP D. MURPHY
Governor

SHEILA Y. OLIVER
Lt. Governor

ELIZABETH MAHER MUOIO
State Treasurer

CHRISTOPHER CHIANESE
Director

November 22, 2022

SUBJECT: Bulletin "O" Dated November 22, 2022
PROJECT #: Project #P1155-02
DESCRIPTION: Re-Build by Design
Coastal Defense – Resist Alignment
Hoboken, Hudson County, NJ

To Whom It May Concern:

WE ARE FORWARDING A COPY OF THE ABOVE REFERENCED BULLETIN. PLEASE ACKNOWLEDGE RECEIPT BY RETURNING THIS FORM TO:

By Email: shawn.taylor@treas.nj.gov or

By Mail: Division of Property Management and Construction
Attention: S. Taylor
Contracts & Procurement
DPMC, PO Box 034
Trenton NJ 08625-0034 or

By Fax: 609-777-1970

Sincerely,

Christopher R. Geary

Christopher R. Geary
Assistant Deputy Director
Contracts and Procurement

11/22/2022

Date Received

E.E. Cruz & Company, Inc.

Firm Name

16-16 Whitestone Expressway, 5th FL, Whitestone, NY 11357

Address

Signature

Joseph F. Sheehan, PE, President

Title



State of New Jersey

DEPARTMENT OF TREASURY
DIVISION OF PROPERTY MANAGEMENT & CONSTRUCTION
P O BOX 034
TRENTON NJ 08625-0034

PHILIP D. MURPHY
Governor

ELIZABETH MAHER MUOIO
State Treasurer

SHEILA Y. OLIVER
Lt. Governor

CHRISTOPHER CHIANESE
Director

December 13, 2022

SUBJECT: Bulletin "P" Dated December 13, 2022
PROJECT #: Project #P1155-02
DESCRIPTION: Re-Build by Design
Coastal Defense – Resist Alignment
Hoboken, Hudson County, NJ

To Whom It May Concern:

WE ARE FORWARDING A COPY OF THE ABOVE REFERENCED BULLETIN. PLEASE ACKNOWLEDGE RECEIPT BY RETURNING THIS FORM TO:

By Email: shawn.taylor@treas.nj.gov or

By Mail: Division of Property Management and Construction
Attention: S. Taylor
Contracts & Procurement
DPMC, PO Box 034
Trenton NJ 08625-0034 or

By Fax: 609-777-1970

Sincerely,
Christopher R. Geary
Christopher R. Geary
Assistant Deputy Director
Contracts and Procurement

12/13/2022
Date Received

E.E. Cruz & Company, Inc.
Firm Name

16-16 Whitestone Expressway, 5th Floor, Whitestone, NY, 11357
Address

[Signature]
Signature

Joseph F. Sheehan, PE, President
Title



State of New Jersey

DEPARTMENT OF TREASURY
DIVISION OF PROPERTY MANAGEMENT & CONSTRUCTION
P O BOX 034
TRENTON NJ 08625-0034

PHILIP D. MURPHY
Governor

SHEILA Y. OLIVER
Lt. Governor

ELIZABETH MAHER MUOIO
State Treasurer

CHRISTOPHER CHIANESE
Director

December 20, 2022

SUBJECT: Bulletin "Q" Dated December 20, 2022
PROJECT #: Project #P1155-02
DESCRIPTION: Re-Build by Design
Coastal Defense – Resist Alignment
Hoboken, Hudson County, NJ

To Whom It May Concern:

WE ARE FORWARDING A COPY OF THE ABOVE REFERENCED BULLETIN. PLEASE ACKNOWLEDGE RECEIPT BY RETURNING THIS FORM TO:

By Email: shawn.taylor@treas.nj.gov or

By Mail: Division of Property Management and Construction
Attention: S. Taylor
Contracts & Procurement
DPMC, PO Box 034
Trenton NJ 08625-0034 or

By Fax: 609-777-1970

Sincerely,
Christopher R. Geary
Christopher R. Geary
Assistant Deputy Director
Contracts and Procurement

12/20/2022
Date Received
E.E. Cruz & Company, Inc
Firm Name
18-16 Whitestone Expressway 5th FL, Whitestone, NY, 11357
Address

Signature
Joseph F. Sheehan, PE, President
Title



State of New Jersey

DEPARTMENT OF TREASURY
DIVISION OF PROPERTY MANAGEMENT & CONSTRUCTION
P O Box 034
TRENTON NJ 08625-0034

PHILIP D. MURPHY
Governor

SHEILA Y. OLIVER
Lt. Governor

ELIZABETH MAHER MUOIO
State Treasurer

CHRISTOPHER CHIANESE
Director

January 5, 2023

SUBJECT: Bulletin "R" Dated January 5, 2023
PROJECT #: Project #P1155-02
DESCRIPTION: Re-Build by Design
Coastal Defense – Resist Alignment
Hoboken, Hudson County, NJ

To Whom It May Concern:

WE ARE FORWARDING A COPY OF THE ABOVE REFERENCED BULLETIN. PLEASE ACKNOWLEDGE RECEIPT BY RETURNING THIS FORM TO:

By Email: shawn.taylor@treas.nj.gov or

By Mail: Division of Property Management and Construction
Attention: S. Taylor
Contracts & Procurement
DPMC, PO Box 034
Trenton NJ 08625-0034 or

By Fax: 609-777-1970

Sincerely

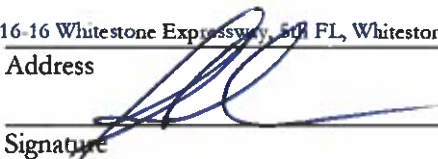
Christopher R. Geary
Assistant Deputy Director
Contracts and Procurement

1/5/2023
Date Received
E.E. Cruz & Company, Inc.
Firm Name
16-16 Whitestone Expressway, 5th FL, Whitestone, NY 11357
Address

Signature
Joseph F. Sheehan, PE, President
Title



State of New Jersey

DEPARTMENT OF TREASURY
DIVISION OF PROPERTY MANAGEMENT & CONSTRUCTION
P O BOX 034
TRENTON NJ 08625-0034

PHILIP D. MURPHY
Governor

ELIZABETH MAHER MUOIO
State Treasurer

SHEILA Y. OLIVER
Lt. Governor

CHRISTOPHER CHIANESE
Director

January 26, 2023

SUBJECT: Bulletin "S" Dated January 26, 2023
PROJECT #: Project #P1155-02
DESCRIPTION: Re-Build by Design
Coastal Defense – Resist Alignment
Hoboken, Hudson County, NJ

To Whom It May Concern:

WE ARE FORWARDING A COPY OF THE ABOVE REFERENCED BULLETIN. PLEASE ACKNOWLEDGE RECEIPT BY RETURNING THIS FORM TO:

By Email: shawn.taylor@treas.nj.gov or

By Mail: Division of Property Management and Construction
Attention: S. Taylor
Contracts & Procurement
DPMC, PO Box 034
Trenton NJ 08625-0034 or

By Fax: 609-777-1970

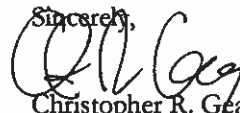
Sincerely,

Christopher R. Geary
Assistant Deputy Director
Contracts and Procurement

1/26/2023
Date Received
E.E. Cruz & Company, Inc.
Firm Name
16-16 Whitestone Expressway, 5th FL, Whitestone, NY 11357
Address

Signature
Joseph F. Sheehan, PE, President
Title



State of New Jersey

DEPARTMENT OF TREASURY
DIVISION OF PROPERTY MANAGEMENT & CONSTRUCTION
P O BOX 034
TRENTON NJ 08625-0034

PHILIP D. MURPHY
Governor

SHEILA Y. OLIVER
Lt. Governor

ELIZABETH MAHER MUOIO
State Treasurer

CHRISTOPHER CHIANESE
Director

February 23, 2023

SUBJECT: Bulletin "T" Dated February 23, 2023
PROJECT #: Project #P1155-02
DESCRIPTION: Re-Build by Design
Coastal Defense – Resist Alignment
Hoboken, Hudson County, NJ

To Whom It May Concern:

WE ARE FORWARDING A COPY OF THE ABOVE REFERENCED BULLETIN. PLEASE ACKNOWLEDGE RECEIPT BY RETURNING THIS FORM TO:

By Email: shawn.taylor@treas.nj.gov or

By Mail: Division of Property Management and Construction
Attention: S. Taylor
Contracts & Procurement
DPMC, PO Box 034
Trenton NJ 08625-0034 or

By Fax: 609-777-1970

Sincerely,

Christopher R. Geary
Assistant Deputy Director
Contracts and Procurement

2/23/2023

Date Received

E.E. Cruz & Company, Inc.

Firm Name

16-16 Whitestone Expressway, 5th Fl, Whitestone, NY 11357

Address

Signature

Joseph F. Sheehan, PE, President

Title



PHILIP D. MURPHY
Governor

SHEILA Y. OLIVER
Lt. Governor

State of New Jersey
DEPARTMENT OF TREASURY
DIVISION OF PROPERTY MANAGEMENT & CONSTRUCTION
P O BOX 034
TRENTON NJ 08625-0034

ELIZABETH MAHER MUOIO
State Treasurer

CHRISTOPHER CHIANESE
Director

April 18, 2023

SUBJECT: Bulletin "U" Dated April 18, 2023
PROJECT #: Project #P1155-02 Re-Bid
DESCRIPTION: Re-Build by Design
Coastal Defense – Resist Alignment
Hoboken, Hudson County, NJ

To Whom It May Concern:

WE ARE FORWARDING A COPY OF THE ABOVE REFERENCED BULLETIN. PLEASE
ACKNOWLEDGE RECEIPT BY RETURNING THIS FORM TO:

By Email: shawn.taylor@treas.nj.gov or

By Mail: Division of Property Management and Construction
Attention: S. Taylor
Contracts & Procurement
DPMC, PO Box 034
Trenton NJ 08625-0034 or

By Fax: 609-777-1970

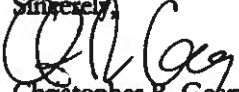
Sincerely,

Christopher R. Geary
Assistant Deputy Director
Contracts and Procurement

4/18/2023
Date Received

E.E. Cruz & Company, Inc.
Firm Name

16-16 Whitestone Expressway, 5th FL, Whitestone, NY 11357
Address

Signature
Joseph F. Sheehan, PE, President
Title



State of New Jersey

DEPARTMENT OF TREASURY
DIVISION OF PROPERTY MANAGEMENT & CONSTRUCTION
P O Box 034
TRENTON NJ 08625-0034

PHILIP D. MURPHY
Governor

SHEILA Y. OLIVER
Lt. Governor

ELIZABETH MAHER MUOIO
State Treasurer

CHRISTOPHER CHIANESE
Director

May 25, 2023

SUBJECT: Bulletin "V" Dated May 25, 2023
PROJECT #: Project #P1155-02 Re-Bid
DESCRIPTION: Re-Build by Design
Coastal Defense -- Resist Alignment
Hoboken, Hudson County, NJ

To Whom It May Concern:

WE ARE FORWARDING A COPY OF THE ABOVE REFERENCED BULLETIN. PLEASE ACKNOWLEDGE RECEIPT BY RETURNING THIS FORM TO:

By Email: shawn.taylor@treas.nj.gov or

By Mail: Division of Property Management and Construction
Attention: S. Taylor
Contracts & Procurement
DPMC, PO Box 034
Trenton NJ 08625-0034 or

By Fax: 609-777-1970

Sincerely,

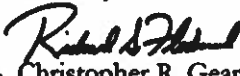
for Christopher R. Geary
Assistant Deputy Director
Contracts and Procurement

5/25/2023
Date Received

E.E. Cruz & Company, Inc.
Firm Name

16-16 Whitestone Expressway, 6th Fl., Whitestone, NY 11357
Address

Signature

Joseph F. Sheehan, PE, President
Title

Bond No. F012401

Document A310™ – 2010

Conforms with The American Institute of Architects AIA Document 310

Bid Bond

CONTRACTOR:

(Name, legal status and address)

E.E. Cruz & Company, Inc.
16-16 Whitestone Expressway, 5th Floor
Whitestone, NY 11357

SURETY:

(Name, legal status and principal place of business)

Liberty Mutual Insurance Company
175 Berkeley Street
Boston, MA 02116

Mailing Address for Notices

Attention: Surety Claims Dept.
1001 4th Avenue, Suite 3800
Seattle, WA 98154

This document has important legal consequences. Consultation with an attorney is encouraged with respect to its completion or modification.

Any singular reference to Contractor, Surety, Owner or other party shall be considered plural where applicable.

OWNER:

(Name, legal status and address)

State of New Jersey, Department of the Treasury
Division of Property Management and Construction (DPMC)
PO Box 034, Trenton, NJ 08625-0034

BOND AMOUNT: \$ (10%) Ten Percent of the Total Amount Bid

PROJECT:

(Name, location or address, and Project number, if any)

Project # P1155-02 - Re-Bid
Re-Build by Design Hudson River Project; Coastal Defense - Resist Alignment
Hoboken, Weehawken and Jersey City - Hudson County, NJ

The Contractor and Surety are bound to the Owner in the amount set forth above, for the payment of which the Contractor and Surety bind themselves, their heirs, executors, administrators, successors and assigns, jointly and severally, as provided herein. The conditions of this Bond are such that if the Owner accepts the bid of the Contractor within the time specified in the bid documents, or within such time period as may be agreed to by the Owner and Contractor, and the Contractor either (1) enters into a contract with the Owner in accordance with the terms of such bid, and gives such bond or bonds as may be specified in the bidding or Contract Documents, with a surety admitted in the jurisdiction of the Project and otherwise acceptable to the Owner, for the faithful performance of such Contract and for the prompt payment of labor and material furnished in the prosecution thereof; or (2) pays to the Owner the difference, not to exceed the amount of this Bond, between the amount specified in said bid and such larger amount for which the Owner may in good faith contract with another party to perform the work covered by said bid, then this obligation shall be null and void, otherwise to remain in full force and effect. The Surety hereby waives any notice of an agreement between the Owner and Contractor to extend the time in which the Owner may accept the bid. Waiver of notice by the Surety shall not apply to any extension exceeding sixty (60) days in the aggregate beyond the time for acceptance of bids specified in the bid documents, and the Owner and Contractor shall obtain the Surety's consent for an extension beyond sixty (60) days.

If this Bond is issued in connection with a subcontractor's bid to a Contractor, the term Contractor in this Bond shall be deemed to be Subcontractor and the term Owner shall be deemed to be Contractor.

When this Bond has been furnished to comply with a statutory or other legal requirement in the location of the Project, any provision in this Bond conflicting with said statutory or legal requirement shall be deemed deleted herefrom and provisions conforming to such statutory or other legal requirement shall be deemed incorporated herein. When so furnished, the intent is that this Bond shall be construed as a statutory bond and not as a common law bond.

Signed and sealed this 30th day of May, 2023.



(Witness)

E.E. Cruz & Company, Inc.
(Principal) *(Seal)*

By: 
(Title) Joseph F. Sheehan, P.E., President



(Witness) Susan L. Kozak-Manna

Liberty Mutual Insurance Company
(Surety) *(Seal)*

By: 
(Title) Lisa M. Scavetta
Attorney-In-Fact



CORPORATE ACKNOWLEDGMENT

Form 152

STATE OF New York

COUNTY OF Queens

On this 31st day of May, 2023, before me personally
came Joseph F. Sheehan, PE to me known, who, being by me
duly sworn, did depose and say that she/he resides in Scarsdale, NY
that she/he is the President of the

E.E. Cruz & Company, Inc. the corporation
described in and which executed the above instrument that she/he knows the seal of said
corporation; that the seal affixed to said instrument is such corporate seal; that it was so
affixed by order of the Board of Directors of said corporation, and that she/he signed
her/his name thereto by like order.

(SEAL)

Ann B. Wieland

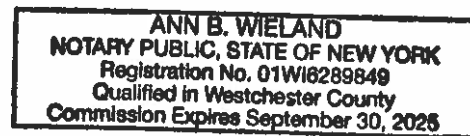

CORPORATE ACKNOWLEDGMENT

Form 152

STATE OF NEW JERSEY
COUNTY OF BERGEN

On this 30th day of May, 2023 before me personally came Lisa M. Scavetta to me known, who, being by me duly sworn, did depose and say that she/he resides in Bronxville, New York that she/he is the ATTORNEY IN FACT of the LIBERTY MUTUAL INSURANCE COMPANY the corporation described in and which executed the above instrument that she/he knows the seal of said corporation; that the seal affixed to said instrument is such corporate seal; that it was so affixed by order of the Board of Directors of said corporation, and that she/he signed her/his name thereto by like order.

(SEAL)

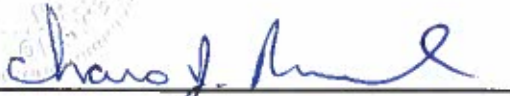

CHARO J. ROSEMOND
NOTARY PUBLIC, STATE OF NEW JERSEY
MY COMMISSION EXPIRES
JUNE 13, 2027



LIBERTY MUTUAL INSURANCE COMPANY
Financial Statement – December 31, 2022

Assets		Liabilities	
Cash and Bank Deposits	\$3,908,755,039	Unearned Premiums	\$10,133,358,204
*Bonds — U.S Government.....	3,451,999,931	Reserve for Claims and Claims Expense.....	27,953,643,316
*Other Bonds	18,862,255,155	Funds Held Under Reinsurance Treaties.....	368,610,620
*Stocks.....	19,372,953,698	Reserve for Dividends to Policyholders	1,379,296
Real Estate.....	190,092,373	Additional Statutory Reserve	197,278,000
Agents' Balances or Uncollected Premiums	7,929,876,358	Reserve for Commissions, Taxes and Other Liabilities	9,206,000,954
Accrued Interest and Rents	166,740,412	Total.....	\$47,860,270,390
Other Admitted Assets.....	15,968,062,977	Special Surplus Funds	\$195,696,103
Total Admitted Assets.....	<u>\$69,850,735,943</u>	Capital Stock	10,000,075
		Paid in Surplus	13,324,803,036
		Unassigned Surplus.....	8,459,966,339
		Surplus to Policyholders	21,990,465,553
		Total Liabilities and Surplus	<u>\$69,850,735,943</u>



* Bonds are stated at amortized or investment value; Stocks at Association Market Values.
 The foregoing financial information is taken from Liberty Mutual Insurance Company's financial statement filed with the state of Massachusetts Department of Insurance.

I, TIM MIKOLAJEWSKI, Assistant Secretary of Liberty Mutual Insurance Company, do hereby certify that the foregoing is a true, and correct statement of the Assets and Liabilities of said Corporation, as of December 31, 2022, to the best of my knowledge and belief.

IN WITNESS WHEREOF, I have hereunto set my hand and affixed the seal of said Corporation at Seattle, Washington, this 8th day of March 2023.

TAMikolajewski

Assistant Secretary



This Power of Attorney limits the acts of those named herein, and they have no authority to bind the Company except in the manner and to the extent herein stated.

Liberty Mutual Insurance Company
The Ohio Casualty Insurance Company
West American Insurance Company

Certificate No: 8208613-974450

POWER OF ATTORNEY

KNOWN ALL PERSONS BY THESE PRESENTS: That The Ohio Casualty Insurance Company is a corporation duly organized under the laws of the State of New Hampshire, that Liberty Mutual Insurance Company is a corporation duly organized under the laws of the State of Massachusetts, and West American Insurance Company is a corporation duly organized under the laws of the State of Indiana (herein collectively called the "Companies"), pursuant to and by authority herein set forth, does hereby name, constitute and appoint, Bianca L. Meli, Charo J. Rosemond, James Baldassare, Jr.; John F. Surano; Krista A. Burke; Lisa M. Scavetta, Maria L. Spadaccini; Michael Dugan; Nicholas F. Walsh; Sherryanne M. DePirro

all of the city of Saddle Brook state of NJ each individually if there be more than one named, its true and lawful attorney-in-fact to make, execute, seal, acknowledge and deliver, for and on its behalf as surety and as its act and deed, any and all undertakings, bonds, recognizances and other surety obligations, in pursuance of these presents and shall be as binding upon the Companies as if they have been duly signed by the president and attested by the secretary of the Companies in their own proper persons.

IN WITNESS WHEREOF, this Power of Attorney has been subscribed by an authorized officer or official of the Companies and the corporate seals of the Companies have been affixed thereto this 18th day of August, 2022.



Liberty Mutual Insurance Company
The Ohio Casualty Insurance Company
West American Insurance Company

By: David M. Carey, Assistant Secretary

State of PENNSYLVANIA
County of MONTGOMERY

On this 18th day of August, 2022 before me personally appeared David M. Carey, who acknowledged himself to be the Assistant Secretary of Liberty Mutual Insurance Company, The Ohio Casualty Company, and West American Insurance Company, and that he, as such, being authorized so to do, execute the foregoing instrument for the purposes therein contained by signing on behalf of the corporations by himself as a duly authorized officer.

IN WITNESS WHEREOF, I have hereunto subscribed my name and affixed my notarial seal at Plymouth Meeting, Pennsylvania, on the day and year first above written.



Commonwealth of Pennsylvania - Notary Seal
Teresa Pastella, Notary Public
Montgomery County
My commission expires March 28, 2025
Commission number 1126044
Member, Pennsylvania Association of Notaries

By: Teresa Pastella, Notary Public

This Power of Attorney is made and executed pursuant to and by authority of the following By-laws and Authorizations of The Ohio Casualty Insurance Company, Liberty Mutual Insurance Company, and West American Insurance Company which resolutions are now in full force and effect reading as follows:

ARTICLE IV - OFFICERS: Section 12. Power of Attorney.

Any officer or other official of the Corporation authorized for that purpose in writing by the Chairman or the President, and subject to such limitation as the Chairman or the President may prescribe, shall appoint such attorneys-in-fact, as may be necessary to act in behalf of the Corporation to make, execute, seal, acknowledge and deliver as surety any and all undertakings, bonds, recognizances and other surety obligations. Such attorneys-in-fact, subject to the limitations set forth in their respective powers of attorney, shall have full power to bind the Corporation by their signature and execution of any such instruments and to attach thereto the seal of the Corporation. When so executed, such instruments shall be as binding as if signed by the President and attested to by the Secretary. Any power or authority granted to any representative or attorney-in-fact under the provisions of this article may be revoked at any time by the Board, the Chairman, the President or by the officer or officers granting such power or authority.

ARTICLE XIII - Execution of Contracts: Section 5. Surety Bonds and Undertakings.

Any officer of the Company authorized for that purpose in writing by the chairman or the president, and subject to such limitations as the chairman or the president may prescribe, shall appoint such attorneys-in-fact, as may be necessary to act in behalf of the Company to make, execute, seal, acknowledge and deliver as surety any and all undertakings, bonds, recognizances and other surety obligations. Such attorneys-in-fact subject to the limitations set forth in their respective powers of attorney, shall have full power to bind the Company by their signature and execution of any such instruments and to attach thereto the seal of the Company. When so executed such instruments shall be as binding as if signed by the president and attested by the secretary.

Certificate of Designation - The President of the Company, acting pursuant to the Bylaws of the Company, authorizes David M. Carey, Assistant Secretary to appoint such attorneys-in-fact as may be necessary to act on behalf of the Company to make, execute, seal, acknowledge and deliver as surety any and all undertakings, bonds, recognizances and other surety obligations.

Authorization - By unanimous consent of the Company's Board of Directors, the Company consents that facsimile or mechanically reproduced signature of any assistant secretary of the Company, wherever appearing upon a certified copy of any power of attorney issued by the Company in connection with surety bonds, shall be valid and binding upon the Company with the same force and effect as though manually affixed.

I, Renee C. Llewellyn, the undersigned, Assistant Secretary, The Ohio Casualty Insurance Company, Liberty Mutual Insurance Company, and West American Insurance Company do hereby certify that the original power of attorney of which the foregoing is a full, true and correct copy of the Power of Attorney executed by said Companies, is in full force and effect and has not been revoked.

IN TESTIMONY WHEREOF, I have hereunto set my hand and affixed the seals of said Companies this 30th day of May, 2023.



By: Renee C. Llewellyn, Assistant Secretary

Not valid for mortgage, note, loan, letter of credit, currency rate, interest rate or residual value guarantees.

For bond and/or Power of Attorney (POA) verification inquiries, please call 610-832-8240 or email HOSUR@libertymutual.com.

ATTENTION
CONSTRUCTION MANAGER AS CONSTRUCTOR (C006) OR GENERAL CONSTRUCTION
(C008) OR SITE WORK (C054)
DPMC PROJECT NO. P1155-02
REBUILD BY DESIGN HUDSON RIVER COASTAL DEFENSE – RESIST ALIGNMENT
HOBOKEN, NEW JERSEY
CCE \$ 196,000,000.00

The State of New Jersey has committed to the construction of the Rebuild By Design Coastal Defense – Resist Alignment Project (Project). The Resist Structure includes hard infrastructure (i.e., walls, floodgates, and supporting drainage features) for coastal defense, as well as soft (i.e., landscaping and public amenity) improvements. This Resist Structure shall adhere to all of the guidelines required by the National Environmental Policy Act (NEPA).

By this Advertisement, the State of New Jersey, Department of the Treasury, Division of Property Management and Construction (DPMC) is soliciting evidence of interest from experienced Contractors for **Project No. P1155-02**, which will consist of a large scale flood mitigation project in Hoboken, New Jersey utilizing linear reinforced concrete walls and movable metal floodgates along with extensive utility relocations.

Pursuant to N.J.A.C. 17:19-2.10, the Director of DPMC has determined that special classification criteria for pre-qualification is required for the Prime Contractor on this Project and for the “Specialty Flood Gates” and “Urban Park Construction” subcontractors.

THIS WILL BE THE ONLY ADVERTISEMENT OF THE PROJECT. ONLY PRIME CONTRACTORS WHO ARE CLASSIFIED AND SPECIALLY PREQUALIFIED FOR THIS PROJECT WILL BE INVITED TO SUBMIT BIDS.

Contractors who wish to be specially prequalified for this Project must be classified with the DPMC as **Construction Manager as Constructor (C006) or General Construction (C008) or Site Work (C054)**. Contractors not currently classified in one of the above trades who wish to be classified should complete the Contractor Classification form (DPMC-27) found at <https://www.state.nj.us/treasury/dpmc/Assets/Files/DPMC-27.pdf> . For any questions about the Contractor Classification process, please contact Katie.Karr@treas.nj.gov.

Contractors seeking prequalification must have experience in the construction of flood control mitigation projects of similar scale and complexity, as described in the Instructions for Form I and in Form I itself. Form I must be fully completed and submitted on or before the deadline.

Only those contractors classified as **CONSTRUCTION MANAGER AS CONSTRUCTOR (C006) OR GENERAL CONSTRUCTION (C008) OR SITE WORK (C054)** and successfully pre-qualified by DPMC will be eligible to bid on this project.

Contractors seeking special prequalification for this Project are required to submit an application for special prequalification (**FORM I**) as set forth below. This application shall also describe proposed subcontractors for special prequalification in the trades of Specialty Flood Gates Vendor/Fabricator and Urban Park Construction. Contractors shall complete the portions of Form I on behalf of the subcontractors they wish to be prequalified. Contractors must submit at least one proposed subcontractor for each of the specialty subtrades, but may submit more than one subcontractor for each of the required subtrades.

If your firm wishes to be considered for pre-qualification for this Project, you must request the necessary Form I and accompanying instructions and pre-register for the project presentation, if you choose to attend, by contacting Shawn.Taylor@treas.nj.gov.

An original and 5 copies of Form I and one electronic copy on a USB drive must be received and time-stamped in the Division of Property Management and Construction (DPMC) Plan Room, 33 W. State Street, 9th Floor, P.O. Box 034, Trenton, NJ 08625 no later than 2:00 p.m., July 27, 2021.

The **Prequalified Subcontractors** named in Form 1 of the Prequalified Prime Contractors' submission will be considered a "Pool" of Subcontractors that can be utilized by any Prequalified Prime Contractor that is invited to submit a bid for Project P1155-02.

A non-mandatory virtual project presentation to familiarize interested bidders will take place at 10:00 AM on June 30, 2021 virtually via Microsoft Teams. Contractors who have pre-registered for the project presentation will be sent the link for the Teams meeting via email.

IT IS HIGHLY RECOMMENDED CONTRACTORS PARTICIPATE IN THIS NON-MANDATORY PROJECT PRESENTATION.

****ATTENTION****

CONTRACTOR PRE-REGISTRATION REQUIRED - SEE BELOW FOR INSTRUCTIONS

The non-mandatory virtual project presentation is scheduled for June 30, 2021 at 10:00 AM. Contractors must **PRE-REGISTER** via email with Shawn Taylor at shawn.taylor@treas.nj.gov **NO LATER THAN 2PM ON June 28, 2021** if they plan to participate.

Contractors who obtain pre-qualification through this process will be notified and required to attend a mandatory pre-bid meeting prior to submission of construction bids.

Design Development, Contract documents, and other informational documents are available electronically. Contractors shall contact Shawn Taylor via email at Shawn.Taylor@treas.nj.gov to request the documents.

During the construction bidding phase, this Project is expected to be bid as a unit price bid including materials and labor for all trades. Bidders must be classified themselves or name their classified subcontractor(s) for the following trades in their construction bid package:

Structural Steel (029)
Plumbing (030)
Electrical (047)

Bidders must be classified by the DPMC under N.J.S.A. 52:35-1, et. seq. and will be required to submit bid security with their final construction bid, as provided in the Instructions to Bidders and General Conditions Revised May 2021. No bidder may withdraw its bid for 60 calendar days after the opening. The State may reject any and all bids.

Pursuant to N.J.A.C. 17:13, this project has been designated as a **Small Business Enterprise Subcontracting Opportunity**.

Note: This contract includes a goal of awarding 25 percent of the total contract value to Small Business Enterprise (SBE) subcontractors and/or suppliers. The firm determined

to be the lowest responsible bidder during the construction bidding process must undertake a good faith effort to seek out and involve SBE subcontractors or suppliers. The successful firm that designates certain subcontractors as SBEs will be required to produce copies of approval notices from the Division of Revenue and Enterprises Services designating each named SBE subcontractor firm(s) as a Small Business Enterprise **prior to the award of contract.**

All questions concerning the Small Business Set-Aside Program should be addressed to:
Division of Revenue and Enterprises Services
Small Business Enterprise
Department of the Treasury
33 West State Street, 5th Floor
P.O. Box 026 Trenton, NJ 08625-0026
Phone: 609-292 2146
www.state.nj.us/njbusiness/contracting

This project is funded in whole or in part by Community Development Block Grant- Disaster Recovery (CDBG-DR) funds received from the U.S. Department of Housing and Urban Development (HUD). The successful bidder following the construction bid process must comply with all applicable Federal CDBG-DR laws, guidelines, and standards in a manner satisfactory to the State of New Jersey and HUD, including, but not limited to, the requirements of Section 3 of the HUD Act of 1968.

Bidders are required to comply with the requirements of P.L. 1975, c. 127 and N.J.A.C. 17:27. The contract resulting from this RFQ/RFP is subject to the requirements of Executive Order No. 125. Accordingly, the Office of the State Comptroller will post a copy of the contract, including the RFQ/RFP, the winning bidder's proposal and other related contract documents for the above contract on the Sandy Transparency website. <http://nj.gov/comptroller/sandytransparency/contracts/sandy/>.

**CHRISTOPHER GEARY, ASSISTANT DEPUTY DIRECTOR
CONTRACTS AND PROCUREMENT
DIVISION OF PROPERTY MANAGEMENT AND CONSTRUCTION
STATE OF NEW JERSEY, DEPARTMENT OF THE TREASURY
P.O. BOX 034
TRENTON, NJ 08625-0034**

MANDATORY VIRTUAL PRE-BID MEETING

PROJECT # P1155-02

PROJECT LOCATION: Hoboken, Hudson County, NJ

DATE: September 1, 2022

TIME: 10:00 AM

CONTACT PERSON: Shawn Taylor

PHONE: 609-292-5229

VIRTUAL MEETING Link [Click here to join the meeting](#)

PLATFORM:

Meeting ID: 265 233 619 242

Passcode: 2Tz8h7

Or

Call-In (Audio Only)

+1 856-338-7074

Phone Conference ID: 471 654 796#

MUST ATTEND TO HAVE VALID BID

SPECIFICATIONS

REBUILD BY DESIGN HUDSON RIVER PROJECT

COASTAL DEFENSE Resist Alignment

Hoboken, Jersey City, Weehawken, Hudson County, NJ

DPMC PROJECT #P1155-02

STATE OF NEW JERSEY

Honorable Phil D. Murphy, Governor
Honorable Sheila Y. Oliver, Lt. Governor

DEPARTMENT OF THE TREASURY
Elizabeth Maher Muoio, State Treasurer

DEPARTMENT OF ENVIRONMENTAL PROTECTION
Shawn M. LaTourette, Commissioner



DIVISION OF PROPERTY MANAGEMENT AND CONSTRUCTION
Christopher Chianese, Director

AECOM Technical Services, Inc.
125 Broad Street, 15th Floor, New York, NY 10004
Certificate of Authorization No. 24GA28042700

Resist Bid Package Issued For Construction

Karen L. Appell
New Jersey Professional Engineer
Lic. 24GE04489000

June 2022

TABLE OF CONTENTS
RESIST BID PACKAGE ISSUED FOR CONSTRUCTION

PART I: INSTRUCTIONS TO BIDDERS AND GENERAL CONDITIONS

ITB and General Conditions

PART II: TECHNICAL CONTRACT SECTIONS

Section #	Description
Division 01 – General Requirements	
011100	Summary of Work
011414	Control of Work
011433	Work in Rights-of-Way
012901	Measurement and Payment
013443	Environmental Procedures
013543	Environmental Engineering Controls
014150	Health and Safety Requirements
014300	Quality Requirements
015000	Temporary Facilities and Controls
015300	Temporary Retaining Structures
015639	Temporary Tree Protection
015713	Erosion Control, Sedimentation, and Containment of Construction Materials
016100	Control of Materials
017329	Cutting, Coring, and Patching
017423	Cleaning Up
017700	Contract Closeout
017823	Operation and Maintenance Manual
Division 02 – Existing Conditions	
020804	Dust and Volatile Emission Control
021600	Excess Clean Fill and Contaminated Materials Management
023214	Vibration and Noise Monitoring
023219	Subsurface Utility Locating (Potholing)
025100	Decontamination

Division 03 – Concrete

031000	Concrete Formwork
031500	Concrete Joints and Accessories
032100	Reinforcement Bars
033000	Cast-In-Place Concrete
033300	Architectural Concrete
033400	Controlled Low Strength Material
033500	Concrete Finishes and Floor Treatment
034500	Site Precast Architectural Concrete

Division 05 – Metals

050513	Shop Applied Coatings for Metal
051200	Structural Steel
055000	Miscellaneous Metal
055001	Site Metal Fabrications
057010	Decorative Metal-Retaining Wall Cladding
057020	Decorative Metal-Trellis Canopy
057300	Decorative Metal Railings and Fences
057500	Decorative Formed Metal
058100	Prefabricated Expansion Joint Assemblies

Division 06 - Wood, Plastics and Composites

061533	Decking
062013	Exterior Finish Carpentry

Division 07 – Thermal and Moisture Protection

071416	Cold Fluid-Applied Waterproofing
074213	Metal Composites Material Panels
07900	Expansion Control
079200	Joint Sealants

Division 08 – Openings

083326	Overhead Coiling Grilles
088400	Glazing Plastics

Division 09 – Finishes

099110	Shop Painting
099702	Coal-Tar Epoxy

Division 10 – Specialties

101400	Signage
--------	---------

Division 11 – Equipment

116800	Play Field Equipment and Structures
--------	-------------------------------------

Division 12 – Furnishings

129300 Site Furnishings

Division 13 – Special Construction

133400 Fabricated Engineered Structures

Division 26 – Electrical

260519 Wires and Cables Less Than 600V
260526 Grounding and Bonding for Electrical Systems
260533 Conduits and Junction Boxes
262000 Electric Winch Motors
262416 Panelboards
262717 Winch Control Panel and Pendant Panel
263213 Portable Generator
263613 Non-Automatic (Manual) Transfer Switches
265619 LED Lighting
265620 Panelboards - LED Lighting

Division 31 – Earthwork

310930 Geotechnical Instrumentation
311000 Site Clearing
312200 Grading
312300 Excavation and Fill
312319 Dewatering
313236 Jet Grouting
313519 Geogrid Slope Protection
314116 Steel Sheet Piling
315000 Excavation Support Systems
316216 Steel Piles
316323 Micropiles
316623 Column Supported Embankment

Division 32 – Exterior Improvements

321200 Flexible Paving
321223 Imprinted Asphalt
321300 Rigid Paving
321343 Pervious Concrete Paving
321400 Unit Paving
321560 Bound Crushed Stone Surfacing
321600 Concrete Curbs, Gutters, and Sidewalks
321710 Asphalt Sidewalks and Driveways
321726 Tactile Warning Surfacing
321813 Artificial Turf
321816 Playground Protective Surfacing
323111 Fence Gate Operators

323113	Chain Link Fences and Gates
323119	Decorative Metal Picket Fences and Gates
323300	Bollards
323900	Manufactured Site Specialties
328400	Planting Irrigation
329113	Soil Preparation and Finish Grading
329123	Structural Soil
329200	Turf and Grasses
329300	Planting
329400	Planting Accessories
329700	Landscape Maintenance

Division 33 – Utilities

331000	Water Utilities
331300	Disinfecting of Water Utility Distribution
333000	Sanitary Sewerage Utilities
333915	Manholes and Structures
334000	Storm Drainage Utilities
334229	Slip-in Inline Check Valves
334235	Flap Gate Check Valves
334237	Slide Gate Check Valves
335000	Gas Utilities
337000	Electric Utilities
338000	Telephone Utilities
338101	Communication Utilities

Division 34 – Transportation

340113	Operation and Maintenance of Roadways
344116	Traffic Control Equipment
347113	Vehicle Traffic Barriers
347120	Beam Guide Rail

Division 35 – Floodgates

353130	Rolling Gates and Appurtenances
353131	Swing Gates and Appurtenances
353132	Stop Logs and Appurtenances

STATE OF NEW JERSEY
DEPARTMENT OF THE TREASURY
DIVISION OF PROPERTY MANAGEMENT AND CONSTRUCTION

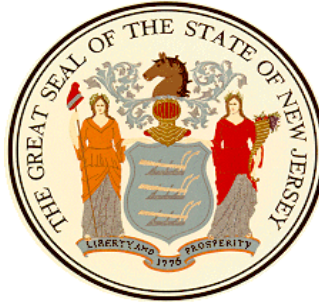

REVISED
MAY 2021

INSTRUCTIONS TO BIDDERS
AND
GENERAL CONDITIONS
FOR
HUDSON RIVER COASTAL DEFENSE – RESIST ALIGNMENT
REBUILD BY DESIGN
HOBOKEN, NEW JERSEY
DPMC PROJECT P1155-02

TABLE OF CONTENTS

INSTRUCTIONS TO BIDDERS

IB 1 Bid Proposals.....	5
IB 2 Bid Modification.....	7
IB 3 Consideration of Bid.....	8
IB 4 Awards.....	9
IB 5 Qualification of Bidders	9
IB 6 Deposit and Bid Bond.....	10
IB 7 Performance and Payment Bond	11
IB 8 Bulletins and Interpretations.....	11
IB 9 Assignments.....	12
IB 10 Federal Excise Taxes and State Sales Tax.....	12
IB 11 Restrictive Specifications	12
IB 12 Offer of Gratuities	13

GENERAL CONDITIONS

ARTICLE 1 - GENERAL PROVISIONS.....	15
1.1 Definitions	15
1.2 Contract Documents to be provided by DPMC.....	17
1.3 Intent of the Contract.....	17
1.4 Workdays.....	19
1.5 Assignments.....	19
1.6 State Sales Tax.....	19
1.7 Easements	19
ARTICLE 2 - OWNER/DPMC.....	20
2.1 DPMC's Representation.....	20
2.2 Right to Perform Work.....	20
2.3 Means and Methods.....	20
ARTICLE 3 - ARCHITECT/ENGINEER	21
3.1 Duties and Responsibilities	21
3.2 Progress Meetings.....	21
3.3 Site Observations.....	21
3.4 Shop Drawings and Submittals and Invoices	21
3.5 Payment Approvals.....	21
ARTICLE 3A - Construction Management Firm.....	22
3A.1 Duties and Responsibilities.....	22
3A.2 Progress Meetings.....	22
3A.3 Site Responsibilities.....	22
3A.4 Shop Drawings and Submittals.....	22
3A.5 Payment Approvals.....	22
ARTICLE 4 - THE CONTRACTOR.....	23
4.1 Review of the Contract Documents and Field Conditions	23
4.2 Insurance.....	24
4.3 Permits, Laws, and Regulations	24
4.4 Responsibility for the Work	25
4.5 Indemnification.....	26

4.6	Supervision	26
4.7	Shop Drawings and Other Submittals	27
4.8	As-Built Drawings	29
4.9	Excavations, Cutting and Patching	29
4.10	Testing	29
4.11	Equipment and Materials	31
4.12	Temporary Facilities	31
4.13	Storage and Site Maintenance	37
4.14	Cut-Overs and Interruptions	38
4.15	Protection/Safety	38
4.16	Uncovering and Correction of Work	39
4.17	Layout and Dimensional Control	41
4.18	Project Sign	41
4.19	Security	41
4.20	Field Office	42
4.21	Photographs	42
4.22	Repair of Finished Surfaces, Applied Finishes, Glass	42
ARTICLE 5 - SUBCONTRACTORS		43
5.1	Subcontractors and Material Supplier Approvals	43
5.2	Contractor-Subcontractor Relationship	43
ARTICLE 6 - CONSTRUCTION PROGRESS SCHEDULE		44
6.1	General	44
6.2	Construction Progress Scheduling Provided by the Contractor	44
ARTICLE 7 - CONTRACT DURATION/TIME OF COMPLETION		47
7.1	Contract Duration/Notice to Proceed	47
7.2	Substantial Completion	47
7.3	Final Completion	47
7.4	Partial Occupancy for Use	48
7.5	Delay, Disruption and Interference	48
ARTICLE 8 - CLOSE-OUT		51
8.1	Close-out Procedures/Final Payment	51
8.2	Operations, Equipment and Maintenance Manuals	51
8.3	Training	51
8.4	Guarantee	51
ARTICLE 9 - PAYMENTS		53
9.1	Invoices	53
9.2	Interest	54
9.3	Schedule of Values and Final Payment	54
9.4	Certification of Payments to Subcontractor	56
9.5	Stored Materials	56
9.6	Allowances	56
9.7	Retainage	57
9.8	Miscellaneous	58
ARTICLE 10 - CHANGES IN THE WORK		59
10.1	Changes in the Work	59
10.2	Acceleration	61
ARTICLE 11 - CLAIMS AND DISPUTES		62
11.1	Contractor Claims	62

11.2	Mutual Rights and Responsibilities of All Contractors and the A/E.....	62
ARTICLE 12 - TERMINATION/SUSPENSION.....		63
12.1	Suspension of the Work / Stop Work.....	63
12.2	Termination for Cause.....	63
12.3	State's Right to Complete the Work.....	64
12.4	Termination for Convenience.....	64
ARTICLE 13 - OTHER REQUIREMENTS.....		66
13.1	Prevailing Wage.....	66
13.2	Patents.....	67
13.3	Right to Audit.....	67
13.4	Insurance.....	68
13.5	Assignment of Antitrust Claims.....	71
END, GENERAL CONDITIONS.....		72

INSTRUCTIONS TO BIDDERS

IB 1 Bid Proposals

IB 1.1 Sealed proposals for the work described herein must be received and time-stamped in the Plan Room, Division of Property Management and Construction (DPMC), 9th Floor, 33 West State Street, P O Box 034, Trenton, NJ 08625-0034. The closing date and time for bids will be communicated to all Prequalified Contractors via Bulletin. Bidders are cautioned that reliance on the US Postal Service or other mail delivery or courier service for timely delivery of proposals is at the bidders' risk. Failure by a bidder to have a sealed proposal reach DPMC by the prescribed time will result in rejection of the unopened submission.

IB 1.2 Bids may be accepted on the following branches of work, as applicable:

- a. Lump Sum All Trades
- b. General Construction
- c. Structural Steel
- d. Plumbing
- e. Heating, Ventilating and Air Conditioning
- f. Electrical
- g. Special Categories as may be required

IB 1.3 Contractors classified by DPMC may obtain contract documents at the DPMC address above, or upon written request, subject to payment of applicable fees. Each bidder is herewith put on notice that its general classification by DPMC is not the sole basis for qualification for the award of work. The Director reserves the right to deny award to any bidder that is not clearly responsible, based upon experience, past performance, financial capability or other material factors, to perform the work required herein.

IB 1.4 The schedule of non-refundable bid fees below is based upon individual trade construction cost estimates. Upon request and at no cost the DPMC will furnish a set of the contract documents for review in the offices of the division at the address noted in paragraph IB1.1 above.

DPMC BID DOCUMENTS FEE SCHEDULE (PER PACKAGE):

<u>TRADE ESTIMATE</u>	<u>DOCUMENT FEE</u>	<u>MAILING FEE</u>
\$100,000 or less	No charge	\$25.00
Greater than \$100,000	\$ 65.00	\$25.00

IB 1.5 Bid proposals based upon the plans, specifications, general, special and supplementary conditions and bulletins shall be deemed as having been made by the bidder with full knowledge of the conditions therein. Bidders are required to visit the site prior to submitting proposals for the work herein described, and to have thoroughly examined the conditions under which the contract is to be executed, including those reasonably observable conditions of the premises which would hinder, delay, or otherwise affect the performance of the contractor required under the terms of the contract. The State will not allow claims for additional costs as a result of the contractor's failure to become aware of the reasonably observable conditions affecting its required performance. The bidder is required to make appropriate allowances in the preparation of the bid for the accommodation of such conditions.

Bidders must warrant in the bid documents that the bidder is familiar with conditions existing at the site at the time the bid is submitted.

IB 1.6 Bid proposals shall be submitted on the standard form provided by DPMC, enclosed in a sealed envelope issued by DPMC. The name and address of the bidder must be indicated on the envelope, as well as indication of the DPMC project number, project location and other appropriate identification.

IB 1.7 All amounts in the bid documents, Lump Sum, Unit Prices and Allowances, shall be stated in numerical figures and written out only. If there is discrepancy between the numerical figures and written amount, the written amount will be used to calculate the total bid cost.

IB 1.8 The bidder must include in the bid envelope: (1) the proposal signed by the bidder, (2) the executed affidavit of non-collusion, (3) the executed Source Disclosure Certification Form as further described in section IB1.11, (4) the executed Disclosure of Investment Activities in Iran Form and (5) bid security as further described in Section IB6.

IB 1.9 Proposals shall remain open for acceptance and may not be withdrawn for a period of 60 calendar days after the bid opening date.

IB 1.10 Proposals not submitted and filed in accordance with instructions contained herein and in the Advertisement for Bids may be rejected as non-responsive.

IB 1.11 Procurement Reform

- a. **RESTRICTIONS ON POLITICAL CONTRIBUTIONS** – In accordance with N.J.S.A. 19:44A-20.13, *et seq.*, bidders submitting a bid on or after October 15, 2004, shall be required to submit a Certification and Disclosure Form and Ownership Disclosure Form for all Business Entities. These forms must be submitted by the bidder and approved prior to contract award.

N.J.S.A. 19:44A-20.13, *et seq.* prohibits State departments, agencies and authorities from entering into a contract that exceeds \$17,500 with an individual or entity that has made a contribution to that political party committee. N.J.S.A. 19:44A-20.13, *et seq.* further requires the disclosure of all contribution to any political organization organized under section 527 of the Internal Revenue Code that also meets the definition of “continuing political committee” within the meaning of N.J.S.A. 19:44A-3(n) and N.J.A.C. 19:25-1.7. The successful bidder shall also be required to adhere to all continuing obligations contained in N.J.S.A. 19:44A-20.13, *et seq.* regarding contributions and disclosures as required in N.J.S.A. 19:44A-20.13, *et seq.*

- b. **Source Disclosure Certification** - Pursuant to N.J.S.A. 52:34-13.2, *et seq.*, all bidders submitting a proposal shall be required to complete a Source Disclosure Certification that all services will be performed in the United States. The bidder shall disclose the location by country where services under the contract will be performed and any subcontracted services will be performed. The Source Disclosure Certification will be attached to the bid proposal.
- c. **MacBride Principles** - Pursuant to N.J.S.A. 52:34-12.2, a bidder must complete a certification on the DPMC form provided prior to contract award to attest, under penalty of perjury, that neither the person or entity, nor any of its parents,

subsidiaries, or affiliates pursuant to N.J.S.A. 52:34-12.2, that the bidder has no ongoing business activities in Northern Ireland and does not maintain a physical presence therein through the operation of offices, plants, factories, or similar facilities, either directly or indirectly, through intermediaries, subsidiaries or affiliated companies over which it maintains effective control; or will take lawful steps in good faith to conduct any business operations it has in Northern Ireland in accordance with the MacBride principles of nondiscrimination in employment as set forth in N.J.S.A. 52:18A-89.8 and in conformance with the United Kingdom's Fair Employment (Northern Ireland) Act of 1989, and permit independent monitoring of their compliance with those principles. If a contractor who would otherwise be awarded a contract or agreement does not complete the certification, then the Director may determine, in accordance with applicable law and rules, it is in the best interest of the State to award the contract or agreement to the next responsible bidder who has completed the certification. If the Director finds the contractor to be in violation of the principles which are the subject of this law, s/he shall take such action as may be appropriate and provided for by law, rule or contract, including, but not limited to, imposing sanctions, seeking compliance, recovering damages, declaring the contractor in default and seeking debarment or suspension of the contractor.

- d. Investment Activities in Iran - Pursuant to N.J.S.A. 52, 32-55, *et seq.*, any person or entity that submits a bid or proposal or otherwise proposes to enter into or renew a contract must complete a certification prior to award on the DPMC form provided to attest, under penalty of perjury, that neither the person or entity, nor any of its parents, subsidiaries, or affiliates, is identified on the Department of Treasury's Chapter 25 list as a person or entity engaging in investment activities in Iran. The Chapter 25 list is found on the Division of Purchase and Property's website at www.state.nj.us/treasury/purchase/pdf/Chapter25List.pdf. Bidders must review this list prior to completing the certification. Failure to complete the certification may render a bidder's proposal non-responsive. If the Director finds a person or entity to be in violation of law, s/he shall take action as may be appropriate and provided by law, rule or contract, including but not limited to, imposing sanctions, seeking compliance, recovering damages, declaring the party in default and seeking debarment or suspension of the party.

IB 2 Bid Modification

IB 2.1 A bidder may modify its bid proposal by electronic mail or letter at any time prior to the scheduled closing time for receipt of bids, provided such communication is received by the DPMC prior to such closing time. A mailed confirmation of any modification signed by the bidder must have been mailed and time-stamped by the US Postal Service prior to the specified closing time. Such confirmation, whether transmitted electronically or by mail, shall be accompanied by a newly executed affidavit of non-collusion.

IB 2.2 Communications shall not reveal the basic bid price but shall only provide the amount to be added, subtracted or modified so that the final prices or terms will not be revealed until the sealed proposal is opened. If written confirmation of the telegraphic modification is not received within two working days after the scheduled closing time, no consideration will be given to the telegraphic modification.

IB 2.3 Bids may be withdrawn upon receipt of a bidder's written request prior to the time fixed for the bid opening. A bidder's right to withdraw a bid is lost after a bid has been opened. If an error has been made in the bid amount, request for relief from the bid may be made in writing to the Director. The written request shall be signed by an authorized corporate officer. A determination of whether the bidder will be released shall be at the sole discretion of the Director, who shall issue a finding within five working days of receipt of all pertinent information relating to such request for relief.

IB 3 Consideration of Bids

IB 3.1 Award of Contracts or Rejection of Bids:

- a. Contracts will be awarded to the lowest responsible bidder. The awards will be made, or the bids rejected, within 60 calendar days from the date of the opening of bids. At the discretion of the Director, a bid extension may be requested from the bidders if circumstances warrant an extension.
- b. The Director reserves the right to award the contract on the basis of the single bid for the entire work, or on the basis of a separate bid and alternate, or any combination of separate bids and alternates, which the Director deems best serves the interest of the State.
- c. The Director reserves the right to waive any bid requirements when such waiver is in the best interests of the State, and where such waiver is permitted by law. Such waiver shall be at the sole discretion of the Director.
- d. The Director reserves the right to reject any and all bids when such rejection is in the best interests of the State. The Director also may reject the bid of any bidder which, in the Director's judgment, is not responsible or capable of performing the contract obligations based on financial capability, past performance, or experience. A bidder whose bid is so rejected may request a hearing before the Director by filing a written notice.

IB 3.2 The bidder to be awarded the contract shall execute and deliver the requisite contract documents, including payment and performance bonds, within the time specified. Upon the bidder's failure or refusal to comply in the manner and within the time specified, the Director may either award the contract to the next low responsible bidder or re-advertise for new proposals. In either case, the Director may hold the defaulting bidder and its surety liable for the difference between the applicable sums quoted by the defaulting bidder and the sum which the State may be obligated to pay to the contractor which is contracted to perform and complete the work of the defaulting bidder.

IB 4 Awards

IB 4.1 In executing a contract, the successful bidder agrees to perform the required work in a good and workmanlike manner to the reasonable satisfaction of the Director, and to complete all work within the number of calendar days specified in its contract.

IB 4.2 Successful bidders will be notified of the time and place for the signing of contracts. Key requirements in the contract, including, but not limited to, the number of days of performance of the contract, manner and schedule of payments, and other administrative details will be reviewed at the award meeting. The time and place of the first job meeting will be announced at the award meeting.

IB 4.3 The State reserves the right to award the contract upon the basis of a single bid for the entire work, or on the basis of separate bids for each prime trade when the total of the separate bids is less than the single bid. Alternates will be accepted or rejected in numerical sequence as cited in the bid documents and shall not be selected at random except as provided herein. Add alternates and deduct alternates will be specified separately. The State may choose from the add and deduct alternates without priority between the two groups so long as selection within each group is in numerical sequence from the first to the last. This limitation shall not apply, however, to any alternates concerning proprietary items. The Director, with the approval of the Using Agency, may accept alternates out of sequence, provided the Director states the reasons for so doing, in writing, within five working days following the opening of bids.

IB 4.4 Should submission of unit prices be required for specified items of work in bid proposals, they will be considered in the evaluation of bids as set forth in the bid proposal form.

IB 4.5 The successful bidder and all of its subcontractors are required to comply with the requirements of N.J.S.A. 10:5-31 et seq., regarding Equal Employment Opportunity in Public Works Contracts.

IB 5 Qualification of Bidders

IB 5.1 If the successful bidder is a corporation not organized under the laws of the State of New Jersey or is not authorized to do business in this State (foreign corporation), the award of the contract shall be conditioned upon the prompt filing by the said corporation of a certificate to do business in this State and complying with the laws of this State in that regard. This filing must be made with the Division of Revenue and Enterprise Services. No award of contract will be made until the Division of Revenue and Enterprise Services confirms this authorization.

IB 5.2 The State requires that each contractor, except in the case of a single contractor, shall perform a minimum of 35 percent of the contract work by the contractor's own forces. However, the Director has the sole discretion to reduce this percentage depending upon the nature and circumstances in any particular case, if the Director determines that to do so would be in the best interests of the State, and provided that the bidder submits a written request with the original bid proposal.

IB 5.3 The State reserves the right to reject a bidder at any time prior to the signing of a contract if information or data is obtained which, in the opinion of the Director, adversely affects the responsibility and/or the capability of the bidder to undertake and to complete the work, regardless of the bidder's previous qualification or classification. The State may

conduct any investigation as it deems necessary to determine the bidder's responsibility and capacity, and the bidder shall furnish all information and data for this purpose as requested by the State.

IB 5.4 Each bidder must be classified by DPMC in accordance with the provisions of the classification statute, NJSA 52:35-1, *et seq.* In the case of a single bid for all of the work, the bidder shall include in the bid the names of its principal subcontractors (in categories as listed in IB1.2 above), which must also be classified in accordance with the said statute.

IB 5.5 At the time of the bid due date, the bidder and the subcontractors must be registered in accordance with “The Public Works Contractor Registration Act”, N.J.S.A. 34:11-56.48, *et seq.* All questions regarding registration shall be addressed to:

Contractor Registration Unit
New Jersey Department of Labor
& Workforce Development
Division of Wage & Hour Compliance
P O Box 389
Trenton NJ 08625-0389
Telephone: 609-292-9464
FAX: 609-633-8591

IB 5.6 In accordance with N.J.S.A. 52:32-44 all contractors and subcontractors providing goods/services to State agencies and authorities are required to provide the contracting agency or authority with proof of registration with the Department of Treasury, Division of Revenue and Enterprise Services. The basic registration process involves the filing of Form NJ-Reg., which can be filed online at www.state.nj.us/njbgs/services.html or by calling (609) 292-7077 or (609) 292-1730.

IB 6 Deposit and Bid Bond

IB 6.1 The Proposal, when submitted, shall be accompanied by a Bid Bond satisfactory to the Director, for the sum of not less than fifty percent (50%) of the Total Bid including alternates, if applicable.

IB 6.2 The Bid Bond shall be properly filled out, signed, and witnessed.

IB 6.3 The Bid Bond shall be accompanied by a copy of the power of attorney executed by the Surety Company or companies. The power of attorney shall set forth the authority of the attorney-in-fact who has signed the bond on behalf of the surety company to bind the company and shall further certify that such power is in full force and effect as of the date of the bond.

IB 6.4 If the bidder whose proposal is accepted is unable to provide the performance and payment bonds or fails to execute a contract, then such bidder and the bid bond surety, where applicable, shall be obligated to pay to the State the difference between the amount of the bid and the amount which the State contracts to pay another party to perform the work. The bidder and the surety shall pay, upon demand, the entire amount of the State's difference in cost. Should there be a deficiency in excess of the bid deposit, the bidder shall make immediate payment to the State for any such deficiency. Nothing contained herein shall be construed as a waiver of any other legal remedies that the State may have against the contractor.

IB 6.5 Attorneys-in-fact who sign bid bonds or contract bonds must file a certified power-of-attorney with the State indicating the effective date of that power.

IB 7 Performance and Payment Bond

IB 7.1 The successful bidder shall furnish within ten (10) calendar days after notice of award both a performance bond in statutory form in an amount equal to one hundred percent (100%) of the total contract price as security for the faithful performance of this contract and a payment bond in statutory form in amount equal to one hundred percent (100%) of the contract price as security for the payment of all persons and firms performing labor and furnishing materials in connection with this contract. The performance bond and the payment bond may be combined or in separate instruments in accordance with law. If combined, they must be for 200% of the award amount. No contract shall be executed unless and until each bond is submitted to and approved by the State. The surety must be presently authorized to do business in the State of New Jersey. In addition to the other coverage provided, the Bond shall cover all Contract guarantees and any other guarantees/warranties issued by the Contractor.

IB 7.2 The cost of all performance and payment bonds shall be paid for by the successful bidder.

IB 7.3 If at any time the State, for justifiable cause, is dissatisfied with any surety which has issued or proposes to issue a performance or payment bond, the contractor shall, within ten calendar days after notice from the State to do so, substitute an acceptance bond (or bonds). The substituted bond(s) shall be in such form and sum and executed by such other surety or sureties as may be satisfactory to the State. The premiums on such bond(s) shall be paid by the contractor. No contract shall be executed and/or no payment made under a contract until the new surety or sureties shall have furnished such an acceptable bond to the State.

IB 7.4 Bonds must be legally effective as of the date the contract is signed. Each must indicate the contractor's name exactly as it appears on the contract. Current attorney-in-fact instruments and financial statement of the surety must be included with the bonds. Bonds must be executed by an authorized officer of the surety. Bonds furnished under this section shall conform in all respects to the requirement and language of NJSA 2A:44-143 to 147.

IB 8 Bulletins and Interpretations

IB 8.1 No interpretation of the meaning of the plans, specifications or other pre-bid documents will be provided to any bidder unless such interpretation is made in writing to all prospective bidders prior to the opening of bids. Any such interpretations must be identified in bid proposals submitted. Any interpretations which are not entered in accordance with this provision shall be unauthorized and not binding upon the State.

IB 8.2 Every request for an interpretation relating to clarification or correction of the plans, specifications, or other bid documents must be made in writing, addressed to the architect/engineer and the DPMC Director, and must be received at least five (5) working days prior to the date fixed for the opening of the bids. Any and all interpretations, clarifications or corrections and any supplemental instructions must be issued by the Director in the form of written bulletins and mailed by certified mail, return receipt requested, or by electronic notice to all prospective bidders not later than three (3) working days prior to the date of the opening of bids. All bulletins issued shall become part of the contract documents and shall be acknowledged in all bid proposals. Failure of a bidder to acknowledge receipt of all such

bulletins and interpretations by the time of bid opening shall result in its proposal being considered non-responsive, at the option of the Director.

IB 8.3 Each bidder shall be responsible for thoroughly reviewing the contract documents prior to the submission of bids. Bidders are advised that no claim for expenses incurred or damages sustained as a result of any error, discrepancy, omission, or conflict in the contract documents shall be recognized by the State unless, and only to the extent that, a written request for interpretation, clarification or correction has been submitted in compliance with Section IB8.2 and provided the matter has not been addressed by the State through the issuance of a bulletin interpreting, clarifying or correcting such error, discrepancy, omission or conflict.

IB 9 Assignments

IB 9.1 The contractor shall not assign all or any part of this contract without written consent of the State. Money due (or to become due) the contractor hereunder shall not be assigned for any purposes whatsoever.

IB 10 Federal Excise Taxes and State Sales Tax

IB 10.1 In general, bidders, in preparing bids, must take into consideration applicable Federal and State tax laws.

IB 10.2 Materials, supplies or services for exclusive use in erecting structures or buildings or otherwise improving, altering or repairing all State-owned property are exempt from the State sales tax. The successful bidder must submit Division of Taxation form ST13, Exempt Use Certificate, to the seller of all materials, supplies or services that will be incorporated into the Work.

IB 10.3 Bidders must determine the current status and applicability of any tax laws, and the contractor may make no claim based upon any error or misunderstanding as to the applicability of any tax laws.

IB 10.4 Purchases or rentals of equipment are not exempt from any tax under the State Sales Tax Act.

IB 11 Restrictive Specifications

IB 11.1 Should any bidder determine before the bid due date that any portion of the specifications or drawings specify a particular product which can be provided by only one supplier or manufacturer, with the result that competitive prices are not available, the bidder shall immediately notify the Director in writing of such fact.

IB 11.2 If such notice is not given in a timely manner, it shall be assumed that the bidder has included the estimate of such sole source in the bid. However, if the Director is notified in a timely manner of the sole source of supply or manufacture, the Director may order the product re-bid or take other lawful action. Such action shall be at the Director's sole discretion.

IB 12 Offer of Gratuities

IB 12.1 Bidders are advised that the laws of New Jersey (NJSA 52:34-19) make it a misdemeanor to offer, pay or give any fee, commission, compensation, gift or gratuity to any person employed by the State. Also, Executive Order #189 (1988) requires that all requests for proposals and contracts issued by the State specify prohibitions on vendor (contractor) activities, the violation of which shall render the vendor liable to ineligibility for State contracts, pursuant to the debarment procedures set forth in N.J.A.C. 17:19-4.1., *et seq.* These prohibited activities include the following:

- a. No vendor shall pay, offer to pay, or agree to pay, either directly or indirectly, any fee, commission, compensation, gift, gratuity, or other thing of value of any kind to any State officer or employee or special State officer or employee, as defined by NJSA 52:34D-13b. and e., in the Department of Treasury or any other agency with which such vendor transacts or offers or proposes to transact business, or to any member of the immediate family, as defined by NJSA 52:13D-13i., of any such officer or employee, or any partnership, firm, or corporation with which they are employed or associated, or in which such officer or employee has an interest within the meaning of NJSA 52:13D-13g.
- b. The solicitation of any fee, commission, compensation, gift, gratuity or other thing of value by any State officer or employee or special State officer or employee from any State vendor shall be reported in writing forthwith by the vendor to the Attorney General and the State Ethics Commission.
- c. No vendor may, directly or indirectly, undertake any private business, commercial or entrepreneurial relationship with, whether or not pursuant to employment, contract or other agreement, express or implied, or sell any interest in such vendor to, any State officer or employee or special State officer or employee having any duties or responsibilities in connection with the purchase, acquisition or sale of any property or services by or to any State agency or any instrumentality thereof, or with any person, firm or entity with which he is employed or associated or in which he has an interest within the meaning of NJSA 52:13D-13g. Any relationships subject to this provision shall be reported in writing forthwith to the Executive Commission on Ethical Standards, which may grant a waiver of this restriction upon application of the State officer or employee or special State officer or employee upon a finding that the present or proposed relationship does not present the potential, actuality or appearance of a conflict of interest.
- d. No vendor shall influence, or attempt to influence or cause to be influenced, any State officer or employee or special State officer or employee in his official capacity in any manner which might tend to impair the objectivity or independence of judgment of said officer or employee.
- e. No vendor shall cause or influence, or attempt to cause or influence, any State officer or employee or special State officer or employee to use, or attempt to use, his official position to secure unwarranted privileges or advantages for the vendor or any other person.

- f. The provisions cited above in paragraphs IB12.1.a. through e. shall not be construed to prohibit a State officer or employee or special State officer or employee from receiving gifts from or contracting with vendors under the same terms and conditions as are offered or made available to members of the general public subject to any guidelines the State Ethics Commission may promulgate under paragraph IB12.1.c. above.

END OF INSTRUCTIONS TO BIDDERS

GENERAL CONDITIONS

ARTICLE 1 - GENERAL PROVISIONS

1.1 DEFINITIONS:

1.1.1 Architect/Engineer: The Architect/Engineer (“A/E”) is the consultant engaged by the DPMC to prepare the design and perform certain contract administration functions in accordance with the provisions of its contract with the DPMC.

1.1.2 Bulletin: A document, issued by DPMC prior to the opening of bids, which supplements, revises or modifies the bid document(s).

1.1.3 Change in the Work: A change in the Project and the Contract Documents, including, but not limited to, an increase or decrease in the Work, an acceleration or extension of time for the performance of the Work.

1.1.4 Change Order: A written order, directing or authorizing a Change in the Work executed by the DPMC and agreed to by the Contractor (except in the case of unilateral change orders executed by DPMC) that includes all adjustments to work, compensation and/or time warranted by the Change in the Work.

1.1.5 Code Official: the individual licensed by the NJ Department of Community Affairs authorized to enforce the NJ Uniform Construction Code (UCC) and approve or reject the Work for NJ UCC compliance.

1.1.6 Construction Management Firm (“CMF”): A person or firm that may be engaged by the DPMC to assist DEP and DPMC in the administration of its contracts.

1.1.7 Contract: The entire and integrated agreement between the Contractor and the DPMC encompassing all of the Contract Documents.

1.1.8 Contract Documents: The executed form of Contract, General Conditions, Supplementary Conditions, Supplementary Instructions, Bulletins, plans, specifications, instructions to bidders, addenda, responses to requests for information, Price Proposal, Change Orders, other amendments, including construction change directives, and all exhibits, appendices and documents attached to or referenced in any of the foregoing materials.

1.1.9 Contract Limit Lines: The lines shown on the Contract Drawings that define the boundaries of the Project, and beyond which no construction work or activities may be performed by the Contractor unless otherwise noted on the drawings or specifications.

1.1.10 Contractor: The business entity with whom the DPMC enters a contract for the performance of the construction of a construction Project by the terms set forth in the Contract Documents.

1.1.11 Contract Price: The sum stated in the Contract, as it may be adjusted in accordance with the Contract Documents, that represents the total amount payable by the State to the Contractor for performance of the Work.

1.1.12 Day: A calendar day, unless otherwise designated.

1.1.12A DEP: The New Jersey Department of Environmental Protection.

1.1.12B: DEP Project Director: The DEP representative designated to assist and direct the CMF with regard to the Contract and the Project Work, or such other person(s) as the

DEP Project Director may authorize to act in his or her behalf.

1.1.13 Director: The DPMC person authorized by statute to administer the design, engineering and construction of all State buildings.

1.1.14 Division of Property Management and Construction (DPMC): The State of New Jersey's contracting agency for the design and construction of State facilities.

1.1.15 Final Acceptance and Completion: The date following receipt, review and acceptance by DEP, the CMF and DPMC of all administrative and close-out documents. Following acceptance, the DPMC will issue a Certificate of Final Acceptance and Completion for the Project.

1.1.16 Generally Accepted Accounting Principles: The common set of accounting principles, standards and procedures that companies use to compile their financial statements. Accounting records must identify all labor and material costs and expenses, whether they are direct or indirect. The identity must include at least the Project number for direct expenses and/or account number for indirect expenses.

1.1.17 Key Personnel: Consultant, Contractor or Subcontractor employees or individual subcontractors or consultants who are directly involved in the project and whose knowledge and experience serves as the basis for their firms' proposal.

1.1.18 NJUCC or Code: The New Jersey Uniform Construction Code which governs the permit and approval process for construction projects.

1.1.19 Notice: A written directive or communication given by the State to the Contractor to act or perform work or carry out some other contractual obligation, or a written communication to be served by the Contractor upon the State. A notice served on the Contractor will be deemed to have been duly served if delivered to an individual or member of the firm or entity or to an officer of the corporation for whom it was intended. This includes regular mail, e-mail, delivery by courier, or registered or certified mail, or facsimile to the Contractor's business address cited in the Contract documents. A notice from the Contractor to the State shall be deemed to have been duly served only if delivered to the Director or the Director's duly authorized representative.

1.1.20 Notice to Proceed: The written communication issued by the DPMC to the Contractor directing the Contractor to begin the Work. The contract calendar day duration period will commence on the effective date noted.

1.1.21 Project: The term for the entire public works engagement. It includes the design, construction work and all administrative aspects required to fully complete the engagement.

1.1.22 Punch List: The list of incomplete or defective Work, compiled by the CMF and the A/E, in consultation with DEP and/or its authorized representative, which remains to be completed after achievement of Substantial Completion.

1.1.23 Schedule: The time tracking mechanism that establishes the Project's allotted time requirements for completion as more specifically described in Article 6 of these General Conditions. When the construction activity items of the schedule have a monetary value associated with them, the schedule is referred to as a "costed" or "cost-loaded" schedule.

1.1.24 Site: The geographical location of the facility or property at which the Work under the Contract is to be performed.

1.1.25 State: The State of New Jersey, acting through DPMC or DEP.

1.1.26 Subcontractor: The business entity that enters into an agreement with the Contractor for the performance of work or materials under this Contract. Also refers to any agreement between a Subcontractor and any of lower tier Subcontractors. Such an agreement creates no relationship, legal or otherwise, between the DPMC and the Subcontractor(s) and/or lower tier Subcontractor(s).

1.1.27 Substantial Completion: The date when all essential requirements of the Contract Documents have been satisfied so that the purpose of the Contract Documents is accomplished, as determined by the DPMC including training of staff by the Contractor on all equipment, and resulting in the issuance of a temporary Certificate of Occupancy, a permanent Certificate of Occupancy or a permanent Certificate of Acceptance and when the Work and the facility can be safely occupied and used in accordance with its intended purpose. DPMC or DEP may condition issuance of a Certificate of Substantial Completion upon satisfactory receipt of critical documents.

1.1.28 Unit Schedule Breakdown: A detailed list of the Work activities required for Project construction, other elements associated with fulfilling the requirements of the Contract (bonds, insurance, etc.), major items of material, labor or equipment, and the prices associated with each of them.

1.1.28 Using Agency: The State department or agency for whom the construction project is being completed.

1.1.29 Work: All construction, supervision, labor, material and equipment necessary to complete the obligations under the Contract including Operation and Maintenance Manuals, Punch List completion, and As-Built Documents.

1.2 CONTRACT DOCUMENTS TO BE PROVIDED BY DPMC

Upon Contract award, the DPMC will furnish to the Contractor, free of charge, three copies of the drawings and specifications, and any additional instructions by means of supplemental contract documents as otherwise necessary for the proper execution of the Work, unless otherwise provided in the Contract Documents. Upon request, additional copies of the contract documents will be furnished at the Contractor's expense.

1.3 INTENT OF THE CONTRACT

1.3.1 The drawings, specifications and all of the Contract Documents are intended to require the Contractor to provide for everything necessary to accomplish the proper and complete finishing of all work. For the Project, the Contractor shall perform all of the obligations and work identified in the Contract Documents, regardless of the manner in which it is divided among the trades or the order in which it appears in the Contract Documents. All work and materials included in the specifications and not shown on the drawings, or shown on the drawings and not in the specifications shall be performed and/or furnished by the Contractor. The Contractor shall include any incidental materials and/or Work not indicated in the drawings and/or the specifications which are nevertheless necessary for the development of the Project and are reasonably inferable from the contract documents and industry practice. The Contractor shall perform all such work and furnish all such materials as if particularly delineated or described in the contract documents as part of the bid proposal.

1.3.2 The Contractor acknowledges that in preparing its bid, the Contractor had the obligation to raise any reasonably observable errors, omissions, ambiguities or

discrepancies and request an interpretation of the alleged errors, omissions, ambiguities or discrepancies. If the Contractor failed to do so, it will have waived all rights to a Change Order or claim and the Contractor will be responsible to complete the Work as required, consistent with the intent of the Contract Documents as interpreted by the DPMC and DEP, without additional compensation.

1.3.3 No interpretation of the meaning of the plans, specifications or other Contract Documents provided prior to bid submission shall be binding upon the State for any purpose unless issued in a Bulletin.

1.3.4 The Contractor shall abide by and comply with the intent and meaning of the Contract Documents taken as a whole, and shall not take advantage of any error or omission, should any exist. Should the Contractor become aware of the existence of any error, omission or discrepancy, the Contractor shall immediately notify the DEP, the CMF and the A/E of any such errors, omissions, ambiguities or discrepancies and seek correction or interpretation thereof prior to commencement of the Work at issue. The A/E will issue a written interpretation. The Contractor shall do no work outside of the Contract Documents, unless written authorization to proceed from the State is received by the Contractor.

1.3.5 Each and every provision required by law to be inserted in the Contract Documents is deemed to have been inserted therein. If any such provision has been omitted or has not been correctly inserted, then upon application of either party, the Contract may be modified to provide for such insertion or correction.

1.3.6 The order of precedence pertaining to interpretation of Contract Documents is as follows:

- a. Executed Contract
- b. Bulletins and Instructions
- c. Supplemental General Conditions
- d. Specifications and General Conditions
- e. Drawings, in the following order of precedence:
 - (1) Notes on drawings
 - (2) Large scale details
 - (3) Figured dimensions
 - (4) Scaled dimensions

1.3.7 Where there may be a conflict in the Contract Documents not resolvable by application of the provisions of this Article, then the more expensive labor, materials, or equipment shall be assumed to be required and shall be provided by the Contractor.

1.3.8 On all work, it shall be the responsibility of the Contractor, by personal inspection of the existing building, facility, plant, utility systems, roadways, or New Jersey Transit property and infrastructure, to ascertain the accuracy of any information given. This shall be the case, whether or not such information is indicated on the drawings, included in the specifications, or shown in any other documentation that is available. The Contractor shall have an affirmative duty to make reasonable inquiry for all available information. The Contractor shall include the costs of all material and labor required to complete the Work

based on inspection and reasonably observable conditions.

1.4 WORKDAYS

Regular working hours will be defined in the Contract Documents. Changes thereto may be granted with written approval of the DEP Project Director. Any work required to be performed after regular working hours or on Saturdays, Sundays, or legal holidays as specially set forth in the Contract documents, as may be reasonably required and consistent with contractual obligations, shall be performed at the amount set forth in the Contractor's bid without additional expense to the State. The Contractor shall obtain written approval of the DEP Project Director for performance of work after regular working hours or on non-regular workdays at least forty-eight (48) hours prior to the commencement of overtime, unless such overtime work is caused by an emergency. If the Contractor seeks such approval for the overtime work, same shall be performed at no additional cost to the State except in the event of an emergency, at which time, the State, in its sole discretion, shall determine if the submitted overtime is compensable.

1.5 ASSIGNMENTS

The Contractor shall not assign all or any part of this Contract without the written consent of the Director. Money due (or to become due) the Contractor hereunder shall not be assigned for any purpose whatsoever without the written consent of the Director.

1.6 STATE SALES TAX

1.6.1 Materials, supplies or services for exclusive use in the construction of structures or buildings or otherwise improving, altering or repairing all State-owned property are exempt from the State sales tax.

1.6.2 Purchases or rentals of equipment are not exempt from any tax under the State Sales Tax Act.

1.7 EASEMENTS

A portion of the Work is to be constructed within easements obtained by the State for private property owners or other State Agencies. The Contractor is to contain his work and operations within the permanent or temporary easements obtained by the State. Easement maps are included in the Contract Documents. Any damage to property or structures outside the easements caused by the Contractor, its employees, Subcontractors, and Vendors or agents, shall be repaired and restored to original condition by the Contractor at no cost to the State.

ARTICLE 2 - STATE/DPMC/DEP

2.1 DPMC REPRESENTATION

The DPMC will be represented on the Project by the DEP Project Director and other representative(s) as may be designated by the DEP Project Director. Such designated representative(s) have only those duties that are required of the State under this Contract.

2.2 RIGHT TO PERFORM WORK

The DPMC or DEP may, and reserves the right to, enter upon the premises at any and all times during the progress of the Work, or cause others to do so, for the purpose of performing any work or installing any apparatus or carrying on any work of any kind not included in the Contract Documents, or for any other reasonable purpose.

The DPMC or DEP shall have the right to defer the beginning of Work or to suspend the whole or any part of the Work whenever, in the sole discretion of the DPMC or DEP, it may be necessary or expedient for the State to do so.

2.3 MEANS AND METHODS

The State will not be responsible for, nor have control or charge of construction means, methods, techniques, sequences of procedures, or safety precautions and programs in connection with the Work. The State will not be responsible for, nor have control or charge of, the acts or omissions of the Contractor, Subcontractors, or any of their agents or employees, or any other person performing any of the Work.

ARTICLE 3 - ARCHITECT/ENGINEER

3.1 DUTIES AND RESPONSIBILITIES

3.1.1 The Architect/Engineer (“A/E”) is the consultant engaged by the DPMC to prepare the design and perform certain contract administration functions in accordance with the provisions of its contract with the DPMC.

3.2 PROGRESS MEETINGS

The A/E will attend and will assist the CMF in issuing record minutes of weekly job progress meetings.

3.3 SITE OBSERVATIONS

3.3.1 The A/E will assist the CMF in monitoring the execution and progress of the Work when necessary. The A/E shall at all times be provided reasonable and safe access to the Work. The Contractor shall provide facilities for such access so as to enable the A/E to perform its functions.

3.3.2 The A/E will not be responsible for, nor have control or charge of construction means, methods, techniques, sequences of procedures, or safety precautions and programs in connection with the Work. The A/E will not be responsible for, nor have control or charge of, the acts or omissions of the Contractor, Subcontractors, or any of their agents or employees, or any other person performing any of the Work.

3.4 SHOP DRAWINGS AND SUBMITTALS

As more specifically described in Article 4, the A/E will review, approve or take other appropriate action relating to Contractor’s submittals, including shop drawings, product data and samples, and as – built drawings, to assure conformance with the requirements of the Contract. Such actions shall be taken with reasonable promptness. Approval of a specific item shall not indicate approval of an assembly of which the item is a component.

3.5 PAYMENT APPROVALS

3.5.1 The A/E will assist the DPMC, the DEP and the CMF with the review of all invoices submitted by the Contractor.

3.5.2 The A/E will assist the DPMC, the DEP and the CMF in reviewing and recommending approval of Contractor closeout documentation in conjunction with the final application for payment.

ARTICLE 3A - CONSTRUCTION MANAGEMENT FIRM

3A.1 DUTIES AND RESPONSIBILITIES

3A.1.1 The CMF is the consultant engaged by the DPMC to perform certain contract administration functions and to assist DEP and DPMC in management of the Project and direction of the work of the Contractor, in accordance with the provisions of its contract with the DPMC. In performance of its duties on the Project, the CMF shall be considered an independent contractor and not an agent of DEP or DPMC, and shall not have the authority to issue binding directives to the Contractor on DEP's or DPMC's behalf.

3A.2 PROGRESS MEETINGS

The CMF will schedule, attend and chair and will issue record minutes of bi-weekly job progress meetings.

3A.3 SITE RESPONSIBILITIES

3A.3.1 The CMF will assist DEP and DPMC in managing the execution and progress of the Work. The CMF shall at all times be provided reasonable and safe access to the Work. The Contractor shall provide facilities for such access so as to enable the CMF to perform its functions.

3A.3.2 The CMF will not be responsible for, nor have control or charge of construction means, methods, techniques, sequences of procedures, or safety precautions and programs in connection with the Work. The CMF will not be responsible for, nor have control or charge of, the acts or omissions of the Contractor, Subcontractors, or any of their agents or employees, or any other person performing any of the Work.

3A.4 SHOP DRAWINGS AND SUBMITTALS

The CMF will assist the A/E and DEP in the review of Contractor's submittals, including shop drawings, product data and samples, and will monitor the Contractor's updating of as-built drawings as the Work progresses.

3A.5 PAYMENT APPROVALS

3A.5.1 The CMF, together with the DPMC and the DEP will review all invoices submitted by the Contractor.

3A.5.2 The CMF, in consultation with the DPMC, the DEP and the A/E, will review and recommend approval of Contractor closeout documentation in conjunction with the final application for payment.

ARTICLE 4 - THE CONTRACTOR

4.1 REVIEW OF THE CONTRACT DOCUMENTS AND FIELD CONDITIONS

4.1.1 The Contractor shall thoroughly examine and be familiar with all of the Contract Documents and the Site. The Contractor shall investigate and accurately determine the nature and location of the Work, the current site conditions including access to the Work, labor and material conditions, and all matters which may affect the Work or its performance.

4.1.2 The Contractor shall be deemed to have verified all reasonably observable conditions outside the Contract limit lines to determine whether any conflict exists with the Work that the Contractor is required to perform under the Contract. This includes but is not limited to a check on elevations, utility connections and other site data. If a condition changed from the time of the bid to the time of the issuance of the Notice to Proceed, the Contractor shall notify the DEP, CMF and A/E immediately. The Contractor shall immediately report any conflicts prior to the bid proposal due date or waive any claim for additional compensation arising from such conflict.

4.1.3 During the progress of the Work, the Contractor shall immediately report in writing any alleged error, inconsistency, ambiguity or omission in the Contract Documents to DEP, the CMF and A/E. The Contractor shall not continue with any work that is affected by such alleged error, inconsistency, ambiguity or omission until the DEP has had the opportunity to respond. Any error, inconsistency, ambiguity or omission shall be addressed pursuant to appropriate procedures set forth in these General Conditions.

4.1.4 Following notification of an alleged error, inconsistency, ambiguity or omission, the DEP may issue supplemental instructions for the proper execution of the Work. The Contractor shall do no work without proper supplemental instructions. In giving such supplemental instructions, the DEP shall have the right to direct the Contractor to make minor changes in the Work without payment of additional monies. This provision is not intended to infringe upon or limit the DEP's and DPMC's authority to otherwise direct changes in the Work, described elsewhere in these general conditions.

4.1.5 Where certain work is shown in complete detail, but not repeated in similar detail in other areas of the drawings, or if there is an indication of continuation with the remainder being shown only in outlines, the Work shown in detail shall be understood to be required in other like portions of the Project.

4.1.6 Unless otherwise directed in writing by the DEP or the DPMC, the Contractor shall perform no portion of the Work without appropriate approvals as may be applicable and required by the Contract Documents.

4.1.7 Unless otherwise provided in the Contract Documents, the Contractor shall provide and pay for all labor, equipment, materials, tools, construction equipment and machinery, water, heat, utilities, transportation and other facilities and services necessary for the proper execution, protection, and completion of the Work.

4.1.8 For this Contract, the designated Key Personnel for the Contractor shall be the Project Manager, Project Superintendent and Site Supervisor(s). Contractor may not substitute Key Personnel without written notice to the DEP Project Director, and prior written approval by the DEP Project Director for such substitution. Such notice should explain the reasons that

Key Personnel are required to be substituted, and give reasonable detail about the proposed substitute personnel so that the DEP Project Director can ensure that the new person has sufficient experience. Approval of all substitutions of Key Personnel shall be at the sole discretion of the DEP Project Director, and shall not be unreasonably withheld.

4.2 INSURANCE

The Contractor shall secure and maintain in force, for the term of the Contract, insurance coverage provided in Section 13.4. The Contractor shall provide the State of New Jersey with current certificates of insurance for all coverage and renewals thereof which must contain a provision that the insurance provided in the certificate shall not be canceled for any reason except after thirty (30) calendar day's written notice to the State of New Jersey. If cancellation occurs, the Contractor shall immediately procure new coverage, not allowing any lapse of coverage to occur.

4.3 PERMITS, LAWS, AND REGULATIONS

4.3.1 The DEP will obtain and pay for any construction and environmental permits and inspections (building, plumbing, electrical, elevator and fire), required by the Department of Community Affairs (DCA). When permits are issued by DCA, the appropriate licensed Contractors and/or Subcontractors shall be required to fill out the Contractor section of the Sub Code Technical Section and sign and affix their raised seal thereto.

4.3.2 Unless otherwise provided in the Contract Documents, the Contractor shall secure and pay for all other permits and governmental fees, licenses and inspections necessary for the proper execution and completion of the Work, and which are legally required at the time of receipt of bids.

4.3.3 All work must be done in accordance with the NJUCC. No work requiring inspections and approval by construction NJUCC code officials is to be covered or enclosed prior to inspection and approval by the appropriate NJUCC enforcement officials.

4.3.4 The Work performed pursuant to this Contract is exempt from local ordinances, codes and regulations as related to the building and the Site on which it is located, except in certain limited circumstances, where construction could adversely affect adjacent property, public sidewalks and/or streets. In those instances, the Contractor shall coordinate its activities with municipal and/or highway authorities having appropriate jurisdiction.

4.3.5 Immediately upon receipt of the contract award documents from the DPMC, the Contractor shall notify all utility companies involved regarding utility services required for completion of the Work. Such notification shall be in addition to any notification requirements imposed by law, including, without limitation, the Underground Facility Protection Act, N.J.S.A. 48:2-73, et seq.

4.3.6 The Contractor shall perform all soil conservation measures in accordance with County Soil Conservation District requirements.

4.3.7 The Contractor shall perform all sewerage disposal work and dispose of all water collected during dewatering operations in conformance with NJDEP regulations.

4.3.8 The Contractor shall be responsible for obtaining timely NJUCC inspections of the

Work from the applicable State agency. The Contractor shall request such inspections through the CMF allowing for sufficient notice to enable NJUCC inspections to be scheduled without delay to the work.

4.3.9 Consistent with section 4.4 of these General Conditions, the Contractor shall be responsible for its own actions and protect, defend and indemnify the State from all fines, penalties or loss incurred for, or by reason of, the violation of any municipal ordinance or regulation or law of the State while the said work is in progress.

4.3.10 The Contractor shall comply with the Federal Occupational Safety and Health Act of 1970 and all of the rules and regulations promulgated there under.

4.3.11 If the Contractor causes a substantial violation of a State, local or federal statute or regulation on the Project, DPMC may declare the Contractor to be in default, and/or terminate the Contract.

4.3.12 Prior to the start of any crane equipment operations, the Contractor shall make all necessary applications and obtain all required permits from the Federal Aviation Administration (FAA). When the FAA has jurisdiction, the sequence of operations, timing and methods of conducting the Work shall be approved by the FAA.

4.3.13 The Contractor shall establish an approved Silica Health and Safety Program when tasks generating crystalline silica dust are being performed. This program shall include engineering, work practice, and respiratory protection controls to reduce worker exposure to airborne respirable crystalline dust to levels that are as low as reasonably achievable. When tasks are performed that generate airborne crystalline dust, the Contractor will minimize worker exposure to dust by one, or a combination of the following methods: 1) dust suppression with water, 2) local exhaust ventilation to a high-efficiency dust collector, and/or 3) appropriate respiratory protection devices. The Contractor shall provide a trained, competent person, as defined by OSHA 29 CFR 1926, on site at all times to implement the Silica Health and Safety Program when tasks generating crystalline silica dust are being performed.

4.4 RESPONSIBILITY FOR THE WORK

4.4.1 The Contractor shall be responsible to the State and to any separate Contractors and/or consultants including, without limitation, the CMF, the A/E, for the acts, errors and omissions of its employees, Subcontractors and their agents and employees that injure, damage or delay such other Contractors and/or consultants in the performance of their work.

4.4.2 The Contractor shall be responsible for all damage or destruction caused directly or indirectly by its operations to all parts of the Work, both temporary and permanent, and to all adjoining property at no cost to the State.

4.4.3 The Contractor shall, at its own expense, protect all finished work and keep the same protected until the Project (or identifiable portions thereof, that are declared as substantially complete and being used) is completed and accepted.

4.4.4 The Contractor shall be responsible for safety and for any damage or injury which may result from the Contractor's failure or improper construction, maintenance or operation.

4.4.5 In order to protect the lives and health of its employees, the Contractor shall comply with all applicable statutes and regulations and pertinent provisions of the "Manual of Accident Prevention in Construction" issued by the Associated General Contractors of America, Inc. and shall maintain accurate records of all cases of death, occupational disease, and injury requiring medical attention or causing loss of time from work arising out of and in the course of employment on work under the Contract. If a conflict should exist with the requirements of the Federal Occupational Safety and Health Act of 1970, then the most stringent statute or pertinent provision shall apply.

4.5 INDEMNIFICATION

4.5.1 The Contractor shall assume all risk of and responsibility for, and agrees to protect, defend and indemnify the State of New Jersey, its agents, and its employees, from and against, any and all claims, demands, suits, actions, recoveries, judgment and costs of expenses in connection therewith on account of the loss of life, property, injury or damage to the person, body or property of any person or persons whatsoever, resulting from the Contractor's performance on the Project or through the use of any improper or defective machinery, implements or appliances, or through any act or omission on the part of the Contractor or its agents, employees or servants, which shall arise from or result directly or indirectly from the Work and/or materials supplied under this Contract. This indemnification obligation is not limited by, but is in addition to, the insurance obligations contained in this Contract.

4.5.2 In any and all claims against the State or any of its agents or employees, any employees of the Contractor or Subcontractor or anyone directly or indirectly employed by any of them, or anyone for whose acts any of them may be liable, the indemnification obligation under this section shall not be limited in any way as to the amount or type of damages, compensation or benefits payable by or for the Contractor or any Subcontractor under worker's compensation acts, disability benefit acts, or other employee benefit acts.

4.6 SUPERVISION

4.6.1 The Contractor shall attentively supervise and direct the Work. The Contractor shall be solely responsible for all construction means, methods, techniques, sequences and procedures and for coordinating all portions of the Work under the Contract.

4.6.2 The Contractor shall employ a full-time competent superintendent and necessary foremen and assistants who shall be in attendance on the Project Site during the progress of the Work. The superintendent shall represent the Contractor, and all communications given to the superintendent shall be binding upon the Contractor. The State reserves the right to require a change in superintendent if the superintendent's performance, as judged by the DEP or the DPMC, is deemed to be inadequate.

4.6.3 The Contractor shall ensure that its Subcontractors shall likewise have competent superintendents in charge of their respective portions of the Work at all times. Upon application in writing, and if deemed appropriate and expressly approved by the DEP, the requirement for a full-time superintendent may be waived. If such a waiver is permitted, the Subcontractor shall employ a full-time competent foreman who shall be in attendance on the site during the progress of work and shall represent the subcontractor, and all

communications given to the foreman shall be binding upon the Subcontractor. The Subcontractor shall not employ persons unfit or unskilled in the assigned area of work. If it becomes apparent that a Subcontractor does not have its portion of the Work under control of a competent foreman, the Contractor shall have the obligation to take appropriate steps to immediately provide proper supervision.

4.6.4 The Contractor shall employ qualified competent craftsmen in their respective lines of work. The State may require evidence that all employees have received sufficient training to execute the Work.

4.6.5 If, due to a trade agreement or project labor agreement, standby personnel are required to supervise equipment installation or for any other purpose during the normal working hours of other trades, the Contractor normally required to provide the standby services shall be deemed to have evaluated and included the costs thereof in its bid price and shall provide said services without additional charge.

4.6.6 The Contractor shall at all times enforce strict discipline and good order among its employees and shall not employ any unfit person or anyone not skilled in the task assigned.

4.6.7 DEP and DPMC reserve the right to request dismissal or substitution of any Contractor personnel, including Key Personnel who are unqualified for their role or who engage in dangerous or illegal activity or cause or contribute to personal injury or property damage in connection with the Project.

4.7 SHOP DRAWINGS AND OTHER SUBMITTALS

4.7.1 The Contractor shall, within two weeks of the Notice to Proceed, submit to the CMF for approval by the A/E, shop drawings and sample submission schedule for approval, which shall be used as a basis for complying with the overall progress schedule. The Contractor shall obtain, from its Subcontractor(s), all submittals including shop drawings, details, and schedules. The Contractor shall review the submittals for completeness and conformity with the Contract Documents, and shall stamp the submittals "approved". The Contractor shall promptly submit to the Construction Manager two copies of each submittal in reproducible form for its review. The shop drawing and sample submission schedule shall be developed so as not to cause any delay in the Contractor's own work or that of any other contractor. The DPMC Project number and the drawing and specification references shall be written or typed on all submissions. Failure to comply with these instructions will be sufficient reason to return the drawing to the Contractor without approval and any resulting delay in the Project shall be the sole responsibility of the Contractor.

4.7.2. The A/E will review shop drawings and other submittals with reasonable promptness. The Contractor shall promptly make any corrections, if required by the A/E, and resubmit a reproducible copy to the Construction Manager for approval by the A/E. Within five (5) working days of final approval, the Contractor shall send the A/E a minimum of seven (7) prints of the finally approved shop drawings as well as seven (7) copies of all catalog cuts, as well as electronic files of all finally approved shop drawings and catalog cuts. The Construction Manager will dictate the appropriate file type for any electronic files submitted by the Contractor.

4.7.3 The Contractor shall prepare original shop drawings, and not simply copy the

Contract Drawings for submission as shop drawings. All shop drawing sizes shall be in multiples of 9" x 12" (e.g., 18" x 24", 24" x 27", 24" x 36", etc.) as approved by the A/E.

4.7.4 Any deviations or changes from the requirements of the Contract Documents, must be approved by the A/E. A Contractor seeking approval for any deviations or changes must: a) make a written request for the proposed change; b) provide to the A/E a detailed narrative description of the proposed change; c) highlight on the applicable drawing the proposed change; and d) furnish a detailed description of all potential impacts on the schedule and project budget.

4.7.5 Substitution of Equipment or other Products

4.7.5.1 Where any particular brand or manufactured article is specified, it shall be regarded as a standard. Similar products of other manufacturers, capable of equal performance and quality, may be accepted if approved by the A/E and CMF and accepted by the DEP Project Director in writing.

4.7.5.2 In the event that a Contractor proposes a substitution to the specified equipment or materials, it shall be the Contractor's responsibility to submit proof of equality and to provide and pay for any tests which may be required by the DEP in order to evaluate the proposal. If there is a substantial cost savings between the substitution and the specified equipment or material, the difference will be returned to the State in the form of a credit Change Order.

4.7.5.3 The application for the approval of a substitution must be submitted on the State form within 10 days of Notice to Proceed. Further, the submission shall include the following requirements:

- a. A Full and complete identification information;
- b. The identification of the paragraph and section of the specifications for which the substitution is proposed. The attachment of data indicating in detail whether and how the equipment or material differs, if at all, from the article specified;
- d. A detailed explanation of any effect the proposed substitution will have on the scope of the Work and a certification that the Contractor agrees to be responsible for any and all resulting added costs to its Work and to any additional costs incurred by the A/E in time, labor and/or redesign of the Contract Documents;
- e. The submission of documents that demonstrate proof of equality, along with an agreement to have such tests performed at the Contractor's own expense as may be required for approval by the DPMC and/or the A/E. The Contractor shall be responsible for the cost of reviews by the A/E of subsequent submissions of additional information.

4.7.5.4 No Contractor shall base a bid on a substitution that may have been approved on previous Projects. Bids shall be based solely on plans and specifications of this Project.

4.7.5.5 The Contractor shall not proceed with the purchase or installation of a substitution without the written approval of the CMF and the DEP Project Director. Any such

installation may result in the assessment of costs for its removal at the Contractor's expense, and/or other damages and/or termination of the Contract for default.

4.8 AS-BUILT DRAWINGS

The Contractor shall maintain on the Project Site at all times one set of drawings to be marked "AS-BUILT". The DEP and CMF shall have the right to rely on the accuracy of the "as-built" drawings provided by the Contractor. During the course of the Project, the Contractor shall mark these drawings with colored pencils to reflect any changes, pile locations and depths, foundation depths, as well as the dimensions and locations of all utilities encountered. These marked-up drawings shall remain current and shall be made available to DEP or the CMF at all times during the progress of the Work.

4.8.1 In instances where shop drawings and/or erection drawings, of a scale larger than the Contract Drawings, are prepared by the Contractor, such drawings may be acceptable "as-built" drawings provided they are updated. A master sheet of the same dimensions as the Contract Drawings shall be prepared by the Contractor that shall indicate, sheet by sheet, a cross-reference to all shop drawings pertaining to that drawing.

4.8.2 The Contractor shall submit the "as-built" documents to the CMF for approval by the A/E with a certification as to the accuracy of the information thereon at the time of Contract completion and before final payment will be made to the Contractor. After review and acceptance by the A/E, the Contractor will furnish two sets of all shop drawings from Article 4.7.2 used for "as-built" documentation.

4.8.3 All "as-built" drawings as submitted by the Contractor shall be dated and labeled "AS- BUILT" above the title block. This information shall be checked, edited and certified by the Architect/Engineer, who will then transpose such information from the Contractor's "as-built" drawings to the original drawings. Where shop drawings have been used by the Contractor for "as-built" documentation, the master sheet providing cross reference information, as described in section 4.8.2, shall be included in the set of "as-built" drawings furnished to DEP.

4.9 EXCAVATIONS, CUTTING AND PATCHING

4.9.1 Soil borings, test pits or other subsurface information may be secured by an independent contractor retained by the State prior to design and construction of the Project and, if obtained, may be included in the Contract Documents for the Contractor's use. The Contractor assumes full responsibility for interpretation of said information.

4.9.2 The Contractor shall be responsible for furnishing and setting of sleeves, built-in items, anchors, inserts, and other necessary materials for its work and for all cutting, fitting, closing in, patching, finishing, or adjusting of its work in new and/or existing construction, as required for the completed installation.

4.10 TESTING

4.10.1 Contractor shall notify the DEP Project Director in writing of all work required to be inspected or tested. The notice shall be provided no later than five working days prior to the scheduled inspection or test. The Contractor shall bear all costs of such inspections or tests,

except for Code inspections as stated in section 4.3 of this document.

4.10.2 When mechanical, electrical or other equipment is installed, it shall be the responsibility of the installing Contractor to maintain, warrant and operate it for such period of time as required by the Contract Documents or as necessary for the proper inspection and testing of the equipment and for adequately instructing the State's operating personnel. All costs associated with the maintenance, warranty, operations, inspection and testing of equipment, as well as instructing State personnel, shall be borne by the Contractor installing the equipment. All tests shall be conducted in the presence of, and upon timely notice to, the DEP, A/E and CMF prior to acceptance of the equipment.

4.10.3 DEP Project Director shall have the authority to direct in writing that special or additional inspections or tests be performed. The Contractor shall comply and give notice as detailed above.

4.10.4 In the event such special or additional inspections or testing reveal a failure of the Work to comply with the terms and conditions of the Contract, the Contractor shall bear all costs thereof, including all costs incurred by the State made necessary by such failures.

4.10.5 Contractor shall utilize inspection or testing from those firms/entities pre-qualified by DPMC. Failure to use a firm/entity pre-qualified by DPMC shall be grounds for rejection of the inspection or test as non-conforming.

4.10.6 All submittals of inspections, test reports or requests for approval shall be accompanied by a certification signed by the Contractor, attesting to: the Contractor's knowledge of the submittal; acceptance of its findings; acknowledgment that material testing meets the required standards; and a certification of the report's representation of the facts. Failure to provide the written certification shall be grounds for rejection of the submittal.

4.10.7 Contractor shall ensure that a copy of the inspection report is transmitted directly to the CMF and the DEP. The Contractor shall ensure that it includes in all of its subcontracts and purchase orders for inspection and testing, the requirement for the inspection or testing firm/entity to submit a copy of the report directly to the DEP Project Director. The Contractor shall ensure that all such reports are submitted within fourteen (14) calendar days of the test or inspection.

4.10.8 In addition to tests performed by the Contractor, the State reserves the right to engage an independent testing agency or firm to perform testing inspections. The Contractor shall provide full access, provide samples, and cooperate fully with this testing agency.

4.10.9 Testing requirements for real property installed equipment (RPIE) to be furnished by the Contractor, when such testing is required by Code, Contract, or the manufacturer, shall be performed by a testing laboratory pre-qualified by DPMC, or in the absence of such, by the manufacturer or its authorized representative. The Contractor shall provide five working days' notice to the DEP Project Director, to allow sufficient opportunity to witness the test.

4.10.10 The DEP Project Director may order that any part of the Work be re-examined by the DEP, and if so ordered, the Contractor shall open or uncover such work for re-inspection by the DEP Project Director. If such work is found to be in accordance with the Contract, the DEP shall pay the cost of re-inspection; however, if such work is not found to be in accordance with the Contract, the Contractor shall be responsible for the cost of

re-inspection and replacement of any defective or non-conforming work.

4.11 EQUIPMENT AND MATERIALS

4.11.1 Contractor warrants that all materials and equipment furnished under the Contract will be new, unless otherwise specified, and that all work will be of good quality, free from faults, defects, and installed in conformance with the Contract Documents. All work not conforming to these requirements, including substitutions not properly approved and authorized, may be considered defective and rejected by the DEP Project Director or the A/E. If required by the A/E or the DEP Project Director, the Contractor shall furnish satisfactory evidence as to the kind and quality of materials and equipment. This warranty shall be in addition to but not in lieu of any other warranty or guarantee provided for in the Contract.

4.11.2 Contractor shall submit to the CMF for approval by the Architect/Engineer an original and six copies of the request for approval of materials on the form provided by DEP for approval. Each item of material listed shall be marked "As Specified", "Substitution" or "Unspecified" as appropriate.

4.11.3 Contractor shall furnish and deliver the necessary equipment and materials in ample quantities and as frequently as required to avoid delay in the progress of the Work and shall store them so as not to cause interference with the orderly progress of the Project.

4.11.4 Contractor shall furnish and pay for all necessary transportation, storage, scaffolding, centering, forms, water, labor, tools, light and power and mechanical appliances and all other means, materials and supplies for properly executing the Work under this Contract, unless expressly specified otherwise in the Contract Documents. The Contractor shall have its representatives at the Site to accept delivered materials. State agencies employees and/or representatives will not accept materials, nor will State agency employees and/or representatives be responsible for damage, theft, or disappearance of the Contractor's materials, equipment, tools, or other property.

4.11.5 Only domestic materials shall be acquired or used for this work unless the Director, or other public officer charged with the duty by law, shall determine it to be inconsistent with the public interest, or the cost to be unreasonable, or domestic materials of the class or kind to be used are not mined, produced or manufactured, as the case may be, in the United States in commercial quantities and of a satisfactory quality.

4.11.6 No materials, equipment, or supplies for the Work shall be purchased by the Contractor subject to any lien or encumbrance or other agreement by which an interest is retained by the seller. This clause shall be a condition included in all agreements between the Contractor and its Subcontractors. The Contractor warrants, by signing its invoice, that it has good and sufficient title to all such material, equipment and supplies used by it in the Work, free from all liens, claims or encumbrances.

4.12 TEMPORARY FACILITIES

4.12.1 The Contractor shall be responsible for providing for its own storage areas, employee vehicular parking and staging areas, excavation borrow/spoils designated areas,

commercial canteen areas, and all other areas necessary for use by the Contractor. The Contractor shall locate these areas to be reviewed and coordinated with the DEP and CMF. These areas must comply with all Municipal regulations and ordinances.

4.12.2 Field Offices - The Contractor shall provide and maintain during the contract duration an on-site suitable weather-tight insulated field office conveniently located, and shall maintain therein a complete set of Contract Documents including plans, specifications, CPM network diagrams, Change Orders, logs and other details and Project correspondence. The Contractor shall maintain the field office until final acceptance or until the DEP Project Director approves its removal. The Contractor shall be responsible to obtain and pay for all permits required for the Contractor's field offices.

4.12.3 Telephones - The Contractor shall provide its own telephones. The State will be responsible only for the cost of calls made by State employees, if there is a documented cost for same.

4.12.4 Storage - The Contractor will provide and maintain, for its own use suitable and safe temporary storage, tool shops, and employees' sheds for proper protection, storage work and shelter. The Contractor shall maintain these structures properly and remove the structures at the completion of work. The Contractor shall be responsible to maintain these facilities and the areas around the facilities in a clear and clean manner. The Contractor shall be responsible for correcting defects and damage caused by such use.

4.12.5 Facilities

- a. The Contractor shall provide and pay for suitable temporary toilets at an approved location on the Site and prior to the start of any field work. The toilet facilities shall comply with federal, State and local laws and regulations. The Contractor will be responsible for maintenance, removal and relocation as described hereinafter.
- b. The Contractor shall provide a temporary toilet and/or indoor toilet connected to water and sewer to accommodate the meeting room and the Architect/Engineer's office, as well as the CMF's office and the DEP office.
- c. Toilets shall be serviced by a qualified and experienced firm authorized to maintain services.
- d. Each portable toilet facility shall be maintained in a neat and clean condition and serviced at least twice a week, including the removal of waste matter, sterilizing, recharging tank, refilling tissue holders, and thoroughly cleaning and scrubbing entire interior. When temporary toilets are connected to water and sewer lines, precautions shall be taken to prevent freezing. The Contractor shall remove the temporary toilet units from the Site at the completion of the Work, or when so directed by the DEP Project Director or the CMF.

4.12.6 Access, Roads and Walks

- a. The Contractor shall be responsible for providing and maintaining unobstructed access to all office trailers and temporary storage areas provided for the Work. The Contractor shall provide and maintain all reasonably required safety devices. The Contractor shall not store or leave during non-work hours, any materials or equipment within municipal rights-of-way without the permission of

the DEP or CMF. The Contractor shall provide any necessary additional materials, grading and compaction, and shall remove snow, ice and debris as necessary to provide and maintain access roadway and pedestrian ways in serviceable and safe condition.

b. The Contractor shall be responsible for providing and maintaining unobstructed traffic lanes, temporary pedestrian walkways, drives and parking areas within or proximate to the Site free and clear of debris, gravel, mud, snow, ice or any other Work zone materials, by ensuring that all reasonably necessary measures are taken to prevent such materials from being deposited on such surfaces. This includes as may be appropriate, the cleaning of vehicle wheels and/or other necessary maintenance, prior to exit from the Construction Work zones. Should such surface require cleaning, the Contractor shall clean these surfaces without additional cost to the State. The Contractor will be held accountable for any citations, fines or penalties imposed on the State for failing to comply with local rules and regulations related to Work zone and off-Work zone maintenance.

c. The Contractor shall not commence final construction of permanent roadways, driveways, parking areas or walks without the written approval of the DEP Project Director. The Contractor shall provide additional materials and labor for maintaining and reworking the sub-grade prior to completion of the Work, to ensure improvements conform fully to the specifications.

d. The Contractor shall obtain written permission from the State for the use of any existing driveways or parking areas not specifically designated for such use in the Contract Documents. If permission is granted, the Contractor shall maintain such driveways and areas in good condition during the construction period, and at the completion of the Project, shall leave them in the same or better condition as at the start of the Work. Conditions before use shall be carefully photographed and documented by the Contractor.

4.12.7 Light and Power

a. The Contractor shall extend sufficient electrical service to the temporary construction offices and all other structures to receive electrical service at locations approved by the DEP Project Director. Temporary electrical service shall be independent of the existing permanent service. Initial temporary service shall be three phase or single phase as indicated in the Contract Documents. The Contractor is responsible to investigate and verify the appropriateness and availability of electrical service with the local utility company prior to the bid date. The Contractor's bid shall be deemed to include all costs associated with providing this power. Temporary light and power installations, wiring, and miscellaneous electrical hardware must meet the electrical Code and will be inspected by NJUCC officials. The Contractor shall provide the necessary distributing facilities and a meter, and shall pay the cost of running temporary services from the nearest utility company power pole. All costs shall be included in the Contractor's bid.

b. In the event that a water well is the source of water supply for the Project, the extension of electrical service shall include the necessary wiring of sufficient capacity to the location of the well for the operation of the well pump. Where service of a type other than herein mentioned is required, the Contractor requiring it shall install and pay all costs of such special service. The size and incoming

service and main distribution switch and panel shall be sized as any service by NEC requirements.

c. The Contractor shall pay for the cost of all electric energy used on distribution lines installed.

d. The Contractor shall provide and pay for all maintenance, servicing, operation and supervision of the service and distribution facilities.

e. If the Contractor fails to carry out its responsibility in the supplying uninterrupted light and power as set forth herein, the Contractor shall be held responsible for such failure, and the DEP Project Director shall have the right to take such action as is deemed proper for the protection and conduct of the Work. Any costs associated with DEP Project Director obtaining or supplying light and power shall be deducted from any payment due to the Contractor.

f. The Contractor shall comply with the requirements of the Federal Occupational Safety and Health Act of 1970 with regard to temporary light and power.

4.12.8 Temporary Enclosures and Heat

Whenever necessary in order to maintain proper temperatures for the execution or protection of the Work, the Contractor shall furnish and maintain temporary enclosures for all openings in exterior walls that are not enclosed with finished materials. Temporary wood doors shall be provided at door openings. Heat for the protection of the Work is to be provided by the Contractor.

4.12.9 Temporary Heating, Ventilation and Air Conditioning

a. Prior to Enclosure - Prior to the building being enclosed by walls and roof, if the outside temperatures falls below 45 degrees Fahrenheit ("F") at any time during the day or night, and heat is required for work in progress or for its protection or curing, the Contractor shall furnish, at its expense, acceptable means to provide sufficient temporary heat to maintain a temperature required by the Work being performed but in no case less than 45 degrees F.

b. Generally Enclosed

(1) For the purposes of establishing the beginning of the Contractor's obligation to provide temporary heat, a building or major unit thereof shall be considered generally enclosed when (a) the exterior walls have been erected, (b) a temporary roof or permanent roof is installed and in a watertight condition, and (c) temporary or permanent doors are hung and window openings are closed with either permanent or temporary weather-tight enclosures. A major unit of buildings as referred to herein shall be: (a) an entire separate structure, or (b) a fully enclosed wing which shall have a floor area equal to at least 50% (fifty percent) of the total floor area of the Project.

(2) As soon as the State determines that the building, or a major unit thereof, is "generally enclosed" by walls and roof, and when the outside temperature falls below 55 degrees F. at any time during the day or night, the Contractor shall furnish sufficient heat by the use and maintenance of LP gas heaters or other acceptable means to maintain a temperature of not less than

55 degrees F. within the enclosed area of the building at all times, and shall remove such heaters when no longer required. The Contractor will be held responsible for providing temporary heat and for all damages resulting from freeze-ups, for the duration of the Project from the time the building is generally enclosed to final acceptance and occupancy. The Contractor shall remove soot, smudges, and other deposits from walls, ceilings, and all exposed surfaces which are the result of the use of heating equipment, including the permanent heating system, during the period of its use for supplying heat. The Contractor shall not do any finish work until the areas are properly cleaned. The Contractor shall provide or arrange, at its own expense, supervision of the heating equipment at all times prior to providing heat, using the permanent heating system. This obligation shall commence immediately after the acknowledged permanent enclosure of the building or buildings, as confirmed by the State. The Contractor shall furnish and pay for all fuel for heat required during the period when the building is generally or permanently enclosed.

(3) The Contractor shall not assume that the permanent heating system or any part thereof will be available for furnishing of temporary heat during the period for which temporary heat is required. The Contractor's base bid price shall therefore include the cost of all equipment necessary for providing temporary heat as required by the Contract Documents. The Contractor may use the permanent heating system, with written approval from the State. Such use however does not cause to commence the equipment's warranties and guarantees. The equipment's warranties and guarantees shall not commence to run until the State takes beneficial use of the Project and facility for the purposes intended.

(4) All heating equipment shall be NFPA-approved and connected to approved flues to the atmosphere. Heaters shall be approved by a recognized testing laboratory and must be equipped with a positive shut-off safety valve.

(5) Storage of gas cylinders within the building will not be permitted at any time.

(6) The Contractor shall provide fire extinguishers on each floor where heaters are used, and the areas must be adequately ventilated.

c. Permanent Enclosure

(1) When the building enclosure has been confirmed by the Architect/Engineer has been completed in accordance with the Contract Documents, and to the satisfaction of the State, it shall be considered permanently enclosed. The Architect/Engineer will also confirm in the job meeting minutes that the building, or a major unit thereof, is permanently enclosed.

(3) The Contractor shall install adequate controls to make such temporary connection as required for the operation of the HVAC system. Should the heating system be designed for the tie-in to existing steam lines for resource of heat, the State will provide steam for temporary heat through the Project permanent heating system, at no cost to the Contractor, after the tie-in is completed by the Contractor.

(4) When the building enclosure has been confirmed by the A/E as completed, the Contractor may request permission to operate the permanent HVAC system to meet its temporary HVAC obligation. The Contractor shall maintain a minimum temperature of 55 degrees F., or a higher temperature, not to exceed 75 degrees F., as may be directed by the Contract Documents for the proper conduct and protection of the Work. The Contractor shall do so until such time as its work is completed and accepted and the Contractor is relieved of this requirement in writing by the State. The Contractor shall pay for and be responsible for the maintenance in accordance with the manufacturer's recommendations, operation and supervision of the HVAC system, including the cost of all water, electricity, and fuel, until the State assumes beneficial occupancy/use of the Project.

4.12.10 Temporary Water

a. The Contractor shall provide, protect and maintain an adequate valved water supply. The Contractor is responsible for all permits and fees required by the municipality and service provider to connect to the water supply. If the source of water supply is a well, provisions covering the supply water will include the installation of necessary power-driven pumping facilities. The well shall be protected against contamination. The water supply shall be tested periodically by the Contractor, and if necessary, shall be chlorinated and filtered. All costs of providing water will be paid for by the Contractor.

b. The Contractor is responsible to protect all temporary and permanent water lines from damage or freezing. Should water connections be made to an existing line, the Contractor shall provide a positive shut-off valve at its own cost and expense.

4.12.11 Standby Personnel

If, pursuant to trade agreement to which the Contractor is a party, the Contractor is obligated to employ standby personnel then the Contractor shall determine and include all such costs thereof in its bid proposal. The Contractor shall not, at any time, make a claim to the State for costs relating to standby maintenance or standby supervision for electric motor-driven or other equipment.

4.12.12 Dust Control

The Contractor shall provide dust control at the Site and all areas affected by the Work, including roads used to haul Work materials. Contractor shall provide a minimum of weekly sweeping and water washdown, more frequently if directed by the CMF, in order to minimize airborne dust.

4.13 STORAGE AND SITE MAINTENANCE

4.13.1 Contractor shall confine its apparatus, the storage of its equipment, tools and materials, and its operations and workers to areas permitted by law, ordinances, permits, and Contract as set forth in the Contract Documents, the rules and regulations of the State, or as ordered by the DPMC. The Contractor shall not unreasonably encumber the Site or the premises with materials, tools and equipment. The Contractor shall not store nor leave during non-work hours, any materials or equipment within municipal rights-of-way without the permission of the DEP or CMF.

4.13.2 Contractor shall, at all times during the progress of the Work keep the premises and the Site free from the accumulation of all refuse, rubbish, scrap materials and debris caused by its operations and/or the actions of its employees, Subcontractors and/or workers, to ensure that, at all times, the premises and Site shall present a neat, orderly and workmanlike appearance. This is to be accomplished as frequently as is necessary by the removal of such refuse, rubbish, scrap materials and debris from the Site. Loading, cartage, hauling and dumping of same will be at the Contractor's expense.

4.13.3 At the completion of the Work, the Contractor shall remove all of its tools, construction equipment, machinery, temporary staging, false work, mock-ups, form work, shoring, bracing, protective enclosures, scaffolding, stairs, chutes, ramps, runways, hoisting equipment, elevators, derricks, cranes, and any other materials and equipment brought onto the Site.

4.13.4 Should the Contractor not promptly and properly discharge its obligation relating to Site maintenance and/or final clean up, the State shall have the right to employ others and to charge the resulting cost to the Contractor after first having given the Contractor a three-working day written notice of such intent.

4.13.5 Contractor's responsibilities for final clean up shall include:

- a. Removal of all debris and rubbish resulting from or relating to the Contractor's work.
- b. Removal of stains from glass and mirrors. Glass shall be washed and polished inside and outside.
- c. Removal of marks, stains, fingerprints, soil, dust or dirt from painted, decorated or stained woodwork, plaster or plasterboard, metal acoustic tile and equipment surfaces.
- d. Removal of spots, paint and soil from resilient, glazed and unglazed masonry and ceramic flooring and wall work.
- e. Removal of temporary floor protections; and cleaning, washing or otherwise treating and/or polishing, as directed, all finished floors.

- f. Cleaning of exterior and interior metal surfaces, including doors, window frames and hardware, of oil stains, dust, dirt, paint, etc. Polishing and removal of fingerprints or blemishes from such surfaces shall be completed, as applicable.
- g. Restoration of all landscaping, roadways and walkways to preexisting condition. Damage to trees and plantings shall be repaired in the next planting season, and such shall be guaranteed for one year from the date of repair and/or replanting.

4.13.6 All construction equipment, materials and/or supplies of any kind, character or description, regardless of value, which remain on the Site for more than 30 (thirty) calendar days from the date of the Certificate of Final Acceptance, shall become the property of the State. Such construction equipment, materials and/or supplies will be disposed of in any manner the State shall deem reasonable and proper. The cost of this disposal shall be deducted from any sums due the Contractor. If the payments then or thereafter due the Contractor are not sufficient to cover such amount, the Contractor shall pay the difference to the State.

4.14 CUT-OVERS AND INTERRUPTIONS

All cut-overs of mechanical and electrical services to existing buildings shall be approved, scheduled and coordinated in advance with the State's representative and performed at a time convenient to the occupants of said buildings so as not to unreasonably interfere with its operations.

4.15 PROTECTION/SAFETY

4.15.1 Safety Precautions and Programs – The Contractor shall be responsible for initiating, maintaining and supervising all required safety precautions and programs in connection with the Work. The Contractor shall designate a responsible member of its organization at the Site whose duty shall be the prevention of accidents. This person shall be competent to review, implement and coordinate the safety programs being performed as required by Occupational Safety and Health Administration (OSHA) or any other agency having authority over safety on a State Construction Site.

4.15.2 Protection of Persons

- a. The Contractor shall take all reasonable precautions for the safety of, and shall provide all reasonable protection to prevent damage, injury or loss to:
 - (1) Every employee on the Site and all other persons who may be affected thereby;
 - (2) All the Work and all materials and equipment to be incorporated therein, whether in storage on or off the Site, under the care, custody or control of the Contractor, or any of its Subcontractor(s) or lower tier sub-Subcontractor(s); and
 - (3) Other property at the Site or adjacent thereto (whether owned by the State or not), including but not limited to trees, shrubs, lawns, walks, pavements, roadways, structures and utilities not designated for removal, relocation or replacement in the course of construction.

b. The Contractor shall give all notices and comply with all applicable laws, ordinances, rules, regulations and lawful orders of any public authority bearing on the safety of persons or property or their protection from damage, injury or loss.

c. The Contractor shall erect and maintain, as required by existing conditions and progress of the Work, all reasonable safeguards for safety and protection, including but not limited to rails, night-lights, aircraft warning lights, the posting of danger signs and other warnings against hazards, promulgating safety regulations, notifying owners and users of adjacent utilities and other means of protection against accidental injury or damage to persons and property.

d. The Contractor shall not load or permit any part of the Work to be loaded so as to endanger the safety of the project, its employees, or any other person on the project Site.

e. The Contractor shall promptly remedy all damage or loss to any property caused in whole or in part by the Contractor, any of its Subcontractors, lower tier Subcontractors, or anyone directly or indirectly employed by any of them, or by anyone for whose acts any of them may be liable and for which the Contractor is responsible. These obligations are in addition to those stated elsewhere herein.

4.15.3 Protection of Property

The Contractor shall have full responsibility to install, protect, and maintain all materials and supplies in proper condition whether in storage or off the site and to immediately repair and/or replace any such damage until Final Acceptance. The Contractor shall maintain an inventory of all materials and supplies for the Work at the Site that are delivered to the site, or delivered to approved off-site storage facilities. The State shall not be liable for any damage, theft or negligent injury to the Contractor's property.

4.15.4 Hazardous Materials

a. When the use or storage of explosives or other hazardous materials or equipment is necessary for the execution of the Work, the Contractor shall exercise the utmost care and shall carry on such activities under the supervision of properly qualified personnel.

b. The Contractor shall maintain all records, reports and files of the general storage and handling of hazardous materials as required by any and all federal, State and/or local regulatory agencies.

4.15.5 Emergencies

In any emergency affecting the safety of persons or property, the Contractor shall act with diligence to prevent threatening injury, damage or loss. In such case, the Contractor shall immediately, but in no case, not more than 24-hours following the emergency, notify the DEP and the CMF of the action taken.

4.16 UNCOVERING AND CORRECTION OF WORK

4.16.1 Uncovering of Work

a. The Contractor is obligated to provide reasonable notice to the DEP Project Director, the CMF and/or the A/E of all work scheduled to be covered, to permit

the DEP Project Director, the CMF the opportunity to inspect the Work prior to actual covering. If any portion of the Work is covered prior to inspection by the DEP Project Director, the CMF, it shall be uncovered for observation. Uncovering and replacement of the covering shall be at the Contractor's expense.

b. The DEP Project Director and/or the CMF may request any work be uncovered by the Contractor for inspection. If such work is found to be in accordance with the Contract Documents, the cost of uncovering and replacement shall, by appropriate Change Order, be reimbursed to the Contractor. If such work is found not to be in accordance with the Contract Documents, the Contractor shall pay all associated costs.

4.16.2 Correction of Work

a. The Contractor shall promptly correct all work rejected by the DEP Project Director, the CMF or the A/E as defective or failing to conform to the Contract Documents, whether observed before or after final acceptance and whether or not fabricated, installed or completed. The Contractor shall bear all costs of correcting such rejected work, including the costs of all consultant services including but not limited to the CMF's and the A/E's additional services.

b. The Contractor shall remove from the Site, at its own expense, all portions of the Work which are defective or non-conforming and which have not been corrected, unless removal is waived by the DEP Project Director.

c. If the Contractor fails to correct defective or non-conforming work in a reasonable time fixed by written notice from DEP Project Director, then the DEP Project Director may make arrangements for such correction by others and charge the cost of so doing to the Contractor.

d. If the Contractor does not proceed with the removal and correction of such defective or non-conforming work within a reasonable time, fixed by written notice from the DEP Project Director, any materials or equipment shall become the property of the State and the State may remove and dispose the non-conforming work in any manner to best meet the interest of the State. If such material is sold and the proceeds of the sale do not cover all costs which the Contractor should have borne and any additional cost incurred by the State in the uncovering, removal, disposal and correction of non-conforming work, the difference shall be charged to the Contractor and an appropriate credit Change Order shall be issued. If the payments then or thereafter due the Contractor are not sufficient to cover such amount, the Contractor shall pay the difference to the State. The Contractor shall be responsible for the cost of making good all work destroyed or damaged by such correction or removal.

e. Notwithstanding other obligations within the Contract Documents, nothing contained herein shall be construed to establish a time or date limitation upon which the State must discover non-conforming work.

4.16.3 Acceptance of Non-Conforming Work

The DEP Project Director and DPMC, with the assistance of the A/E and CMF may determine that the best interests of the State will be served by accepting defective or non-conforming work instead of requiring its removal and correction. In such instance, the DPMC may, by any means available, exact an appropriate reduction in the Contract sum.

Such adjustment shall be effected regardless of final payment having previously been made, and the Contractor and/or its surety shall be responsible for promptly remitting any funds due the State as a result thereof.

4.17 LAYOUT AND DIMENSIONAL CONTROL

4.17.1 Contractor shall be responsible for locating and laying out the Work, including all structures, piping and all of its parts on the site, in strict accordance with the Contract Documents, and shall accurately establish and maintain dimensional control. The Contractor shall employ and pay for the services of a competent and licensed New Jersey engineer or land surveyor who shall be pre-qualified by DPMC to perform all layout work.

4.17.2 Contractor's engineer/surveyor, in the course of layout work either on the Site or along any structure or within any building, shall establish all points, lines, elevations, grades and bench marks for proper control and execution of the Work. The Contractor's engineer/surveyor shall establish multiple permanent benchmarks needed to control the Work as set forth in the Contract Documents to which all three coordinates of dimensional control shall be referenced. The Contractor's engineer/surveyor shall verify all furnished survey data in the Contract Documents including but not limited to topographical and utility location points, lines, elevations, grades and benchmarks, and buildings. Should any discrepancies be found between information given on the Contract Documents and the actual site or field conditions, the Contractor shall notify DEP, the A/E and the CMF in writing of such discrepancy, and shall not proceed with any work affected until receipt of written instructions from the DEP or CMF.

4.18 PROJECT SIGN

The Contractor shall erect and maintain signs at the Site, as set forth in the Contract Documents and located as directed by the CMF. Painting shall be done by a professional sign painter, with two coats of exterior paint, colors, letter face and layout as shown. No other sign will be permitted at the Site. Upon completion of the Project, and when directed by the CMF or the DEP Project Director, the Contractor shall remove the sign.

4.19 SECURITY

4.19.1 The Contractor shall be responsible for the protection of the Work from all damage including defacement of all structures, until final acceptance of the Work by the State. The Contractor is responsible for the security of all temporary structures used for the Project, including structures used by the DEP, CMF and A/E.

4.19.2 The Contractor shall provide all locks, doors and security construction and personnel as required to secure the Project building throughout the period of construction.

4.19.3 The Contractor shall be responsible for the security of any temporary structures located on the premises outside of the building and/or any stored materials.

4.20 FIELD OFFICE

4.20.1 Contractor shall provide on-site, suitable, separate, weather-tight, insulated (floor, walls, ceilings) field office facilities for the use of DEP personnel and separate field offices for the CMF and A/E, as more fully described in the Contract Documents. At a minimum, the Contractor is to supply these field offices with toilet facilities, heating and air conditioning, tables and chairs, and phone and data communication lines. At a time determined by the DEP Project Director or the CMF, the Contractor shall remove field facilities and shall relocate the contents and operations of the field office to the interior of the Project building until completion of the Project.

4.20.2 The Contractor shall be responsible for the maintenance of all temporary field offices including the cost of heating, air conditioning, electric service and janitorial service.

4.21 PHOTOGRAPHS

4.21.1 The Contractor shall submit monthly progress photographs in duplicate to the CMF, giving six (6) views of the Work with each application for payment until the Project is completed.

4.21.2 The photographs shall be 8" by 10" shall bear the date and time of the exposure, the DPMC Project number and title, the names of the Contractor and the name of the A/E. All photographs shall also be submitted in digital format.

4.22 REPAIR OF FINISHED SURFACES, APPLIED FINISHES, GLASS

4.22.1 The Contractor accepts sole responsibility for repair of uncontrolled dislodging, cracking, delaminating or peeling of finished surfaces such as concrete, pre-cast concrete, cast and natural stone, unit masonry, millwork, plaster, glass and applied finishes such as compound, paint, and special coatings, within the Contract Work and the limits of specified guarantee periods, regardless of the cause.

4.22.2 The Contractor shall be responsible for replacement of all broken glass, regardless of the cause. The Contractor shall replace all broken, scratched or otherwise damaged glass before the completion and acceptance of the Work. If breakage is caused by the State, the Contractor will be reimbursed for the replacement costs. The Contractor shall wash all glass on both sides at completion, or when directed, removing all paint spots, stains, plaster, and other materials.

ARTICLE 5 - SUBCONTRACTORS

5.1 SUBCONTRACTORS AND MATERIAL SUPPLIER APPROVALS

5.1.1 Upon their execution, but not less than fourteen (14) calendar days prior to Subcontractor mobilization on the site, and/or Subcontractor billing, the Contractor shall forward to the CMF on the form provided by the DPMC the names of all its Subcontractors and suppliers, of such others as the DPMC may direct, proposed to perform the principal parts of the Work. The Contractor shall forward the appropriate DPMC form to the CMF for approval. Department of Labor and Workforce Development Public Works Contractor Registration and New Jersey Business Registration Certificate are required for all Subcontractors.

5.1.2 If the DPMC or DEP has objection to any proposed or approved Subcontractor and/or material supplier, the Contractor shall substitute another Subcontractor and/or material supplier acceptable to DPMC and DEP. Under no circumstances shall the State be obligated for additional cost due to such substitution.

5.1.3 After the acceptance of bids, the Contractor shall make no substitution of any Subcontractor person or firm previously selected and approved, without prior written approval from the CMF, DEP and DPMC. A Contractor seeking to substitute a Subcontractor person or firm shall provide written request for substitution no less than fourteen (14) calendar days prior to the execution of Work by the Subcontractor or material supplier.

5.1.4 Approval of a Subcontractor or material supplier by the DPMC, DEP and CMF shall not relieve the Contractor of the responsibility of complying with all provisions of the Contract Documents. The approval of a Subcontractor or material supplier does not imply approval of any construction, material, equipment or supplies.

5.2 CONTRACTOR-SUBCONTRACTOR RELATIONSHIP

5.2.1 The Contractor acknowledges its full responsibility to the State for the acts and omissions of its Subcontractors and lower tier subcontractors, and of persons and firms either directly or indirectly employed by them, equally to the extent that the Contractor is responsible for the acts and omissions of persons and firms directly or indirectly employed by it. The Contractor acknowledges that it remains fully responsible for the proper performance of its Contract regardless of whether work is performed by the Contractor's own forces or by Subcontractors engaged by the Contractor.

5.2.2 Nothing contained in the Contract Documents shall create any contractual relationship between any Subcontractor and the State. Further, no Subcontractor or material supplier shall be deemed an intended third party beneficiary under this Contract.

5.2.3 The Contractor shall require, in its agreements with Subcontractors and as a condition of agreement, that each Subcontractor require in its agreement(s) with lower tier Subcontractors and Suppliers, that the Subcontractor understands that there is no contractual obligation of any kind between the State and Subcontractor and the Subcontractor's sole recourse lies with the Contractor and/or the surety, and not with the State, that each Subcontractor and lower tier Subcontractor, bound by the terms of the Contract Documents for this Contract, and assume toward the Contractor all the obligations and responsibilities which the Contractor assumes, pursuant to the Contract Documents.

ARTICLE 6 - CONSTRUCTION PROGRESS SCHEDULE

6.1 GENERAL

The State may contract for the services of a Critical Path Method (CPM) scheduling consultant for Project planning, scheduling and cost control. If such has been arranged, then section 6.2 shall apply to the Contract between the State and the Contractor. In the absence of a statement in the bid documents that a CPM consultant has been retained by the State, then section 6.3 shall apply.

6.2 CONSTRUCTION PROGRESS SCHEDULING PROVIDED BY THE CONTRACTOR

6.2.1 The Project shall be completed within the specified number of calendar days from the effective date of the Notice to Proceed.

6.2.2 The Contractor shall be responsible for preparing and furnishing to the DEP Project Director through the CMF before the first Contract requisition date, but in no event later than 30 (thirty) days after the effective date of the Notice to Proceed, a coordinated combined progress schedule that incorporates the progress schedules of the Contractors and all Subcontractors engaged on the Project. The schedule shall be in the form of a network diagram or other recognized graphic critical path progress schedule format that indicates, among other things, predecessor and successor activities, and major and intermediate milestones, in sufficient detail to satisfy the DEP and the CMF. (See also section 6.3.4 below.) The Contractor shall use scheduling software Primavera P6 or equal with the approval of the CMF. The Contractor's initial invoice will not be processed by the DPMC until and unless such a single coordinated progress schedule has been submitted to and approved by the DPMC. Thereafter, the Contractor shall submit an updated coordinated progress schedule on a monthly basis. Receipt and approval of the updates will be a mandatory condition to payment.

6.2.3 Once each month, or more often if required by the CMF, the Contractor shall meet with the CMF and the D E P representative to gather the information necessary for the Contractor's preparation of the revised/updated computer generated scheduling reports.

6.2.4 The progress schedule, based upon the logic and time estimates based on a seven (7) day calendar, shall indicate in suitable detail for display, all significant features of the Work of the Contractor and each Subcontractor, including but not limited to, the placing of orders, manufacturing durations, anticipated delivery dates for critical and long-lead items, submissions and approvals of shop drawings, construction activities, all work activities to be performed by the Contractor and its Subcontractors, the beginning and time duration thereof, and the dates of all milestones, substantial and final completion of the various elements of the Work, including punch list and close-out. The Contractor shall consider availability of work zone areas in the planning and scheduling of work as noted in the Contract Documents. Reports shall be in booklets, indexed and separated as categorized below. Each activity listed on the Schedule shall include, as a minimum, the following:

- a. The activity description;

- b. The Work or trade(s);
- c. The duration in calendar days;
- d. The Early Start date;
- e. The Late Start date;
- f. The Early Finish date;
- g. The Late Finish date;
- h. The Total Float

6.2.5 The Contractor agrees that no time extension will be granted for time lost due to normal seasonal weather conditions. In order to qualify for consideration for a time extension due to adverse weather conditions, it must be shown by clear and convincing evidence that the weather conditions during a given quarterly period (summer, fall, winter, spring) were more severe than the previous five-year (5) average for the Project geographical area, and that these weather conditions critically impacted the final Project completion date by delaying the performance of work. If abnormal weather losses can be shown to have impacted the Project completion date, a non-compensable time extension will be considered for that portion of the proven weather-related delays, which exceeded normal weather losses that should have been anticipated for the quarterly period in question.

6.2.6 Immediately upon approval by DEP and the CMF, the Contractor shall prepare and distribute four copies of the progress schedule to the DEP plus two copies to the CMF and the A/E. Each monthly updated coordinated schedule shall be signed and dated by the Contractor.

6.2.7 The Contractor shall furnish sufficient labor and construction plant and equipment to ensure the execution of the Work in accordance with the approved progress schedule. If any updated completion time or date for any activity does not conform to the durations or milestones shown in the approved progress schedule, the sequence of activities and/or the time for performance of activities shall be updated on the progress schedule to be approved by the DEP and the CMF and cured by the Contractor by any means, including performing concurrent operations, additional manpower, additional shifts, and overtime. No additional charges to the State will be allowed the Contractor for overtime, additional manpower, equipment, additional shifts, etc. (except as may be provided elsewhere in the Contract), if such expediting procedures or measures are necessary to meet the Contract completion date.

6.2.8 The progress schedule shall show:

- a. Recommended changes in activity sequencing;
- b. Changes in activity duration for activities not started or partially completed, where agreed upon;
- c. The effect on the network of the modifications (activity duration, Predecessors and Successors);
- d. Changes for the purposes of regaining lost time or improving progress, and;
- e. Changes to milestones, due dates, and the overall Contract completion date, which have been agreed upon by the DPMC's project manager since the last

revision of the progress schedule.

6.2.9 The progress schedule shall accurately reflect the manner in which the Contractor intends to proceed with the Project and shall immediately incorporate and reflect the impact of all delays and change orders. All changes made to the schedule shall be subject to approval by the DEP and the CMF.

6.2.10 The DEP will not authorize or approve any claims for additional payment or extension of time for completion of the Work, or any other concession because of any alleged misinterpretation or misunderstanding on the Contractor's part of the Project schedule, the Contractor's failure to attend the pre-bid conference, because of any failure on the Contractor's part to become fully acquainted with all conditions relating to the Project schedule and the manner in which it will be used on the Project, or because of any other failure by the Contractor to properly participate in the development of a progress schedule or to perform the Contract in accordance with the progress schedule.

ARTICLE 7 - TIME OF COMPLETION

7.1 CONTRACT DURATION/NOTICE TO PROCEED

7.1.1 Contract duration shall commence on the effective date set forth on the written Notice to Proceed. The Notice to Proceed will be issued by the DPMC after the DPMC's receipt and acceptance of properly executed Contract Documents, including performance and payment bonds, proof of insurance and permit technical information submitted by the Contractor and/or Subcontractors. The Contractor shall not be entitled to delay, disruption, acceleration or any other claims arising from a deferred issuance of the Notice to Proceed.

7.1.2 The Contractor shall perform no work at the Contract Site prior to the issuance of the Notice to Proceed.

7.2 SUBSTANTIAL COMPLETION

7.2.1 At the request of the Contractor, the CMF, the A/E and the DEP may make a joint inspection of the Work for the purpose of determining if the Work is substantially complete in accordance with the definition provided in Article 1. If the CMF finds that the Work is substantially complete, then the DPMC will issue a written Notice of Substantial Completion for Beneficial Use. Such Notice shall in no way relieve the Contractor of any contractual obligation(s) or relieve the Contractor from responsibility to promptly complete all remaining Contract Work including, but not limited to, punch list items.

7.2.2 The standard guarantee period for equipment, workmanship and materials shall commence on the date DPMC issues the Notification of Substantial Completion for Beneficial Use, or from the time of completion and acceptance of equipment, work or materials in question, whichever is later.

7.2.3 In the event that the Project is completed in phases or stages, and/or in the event that the DEP takes possession of any part of the Work pursuant to Section 7.4 of these General Conditions, no part of the Project shall be deemed substantially complete for purposes of the New Jersey Statute of Repose, N.J.S.A. 2A:14-1.1, prior to the issuance of a formal Notice of Substantial Completion for Beneficial Use for the all of the Work.

7.3 FINAL COMPLETION

7.3.1 Final completion of the Contract shall occur when:

- a. The DEP, the CMF and the A/E have determined that the punch list has been completed;
- b. The Contractor has complied with the Contract Document's closeout requirements;
- c. The Contractor has submitted all Contract deliverables as required by the Contract Documents including but not limited to the following: "as-built" documents, operating and maintenance manuals, attic stock, parts lists, repair source lists, training and certificates; and

- d. The Contractor has submitted all warranties, guarantees and/or maintenance bonds required under the Contract.

7.4 PARTIAL OCCUPANCY FOR USE

7.4.1 Use and possession prior to completion: The DEP shall have the right to take possession or use of any completed or partially completed part of the Project. Said possession or use shall not be deemed acceptance of the Work performed on the Project.

7.4.2 Prior to such possession or use, the DEP shall furnish the Contractor with an itemized list of Work remaining to be performed or corrected on such portions of the Project that are to be possessed or used by the State. Failure by the DEP Project Director to list any item of work shall not be deemed an acceptance of any Work under the Contract.

7.4.3 The Contractor shall not be entitled to recovery of money damages for any delays, disruptions or inefficiencies caused by such partial occupancy.

7.5 DELAY, DISRUPTION AND INTERFERENCE

7.5.1 Delay - Time Extension. If the Contractor's work is delayed, disrupted or interfered with by act, neglect or default of any party, including the State, the CMF, the A/E, or by strikes, lockouts, fire, unusual delay by common carriers, natural disasters, or by any cause for which the Contractor is not responsible; then for all such delays and suspensions, the Contractor shall be allowed one (1) calendar day addition to the time herein stated for each and every calendar day of such delay so caused in the completion of the Work as specified above, the same to be determined by the DPMC. No such extension shall be granted for any delay unless, within ten (10) calendar days after the beginning of such delay, a written request for additional time shall be filed with the DEP and approved by the DPMC.

7.5.2 Contractor's Damages for Delay, Disruption or Interference

The Contractor shall not be entitled to recovery of money damages from the State caused by delay, disruption or interference with the Contractor's Work except as expressly provided under section 7.5.2 of these General Conditions. The Contractor expressly agrees that the Contractor's remedy for delay, disruption or interference shall be limited to an extension of time only and that there shall be no recovery of money damages by the Contractor for any delay, disruption or interference with the Contractor's work attributable to any cause whatsoever (other than the State's negligence, bad faith, active interference or other tortious conduct). The Contractor expressly agrees that it shall not be entitled to recover damages due to delay, disruption or interference caused by any of the following:

- a. Delayed execution of the contract or any of the causes referenced in paragraph 7.5.2;
- b. Any act or omission by any party other than the State, including, but not limited to, the CMF, the A/E, any other Contractor or Subcontractor, any CPM or other consultant retained by the State, any construction manager retained by the State, any agency or instrumentality of

the federal government or of any local governmental entity or any utility (e.g., gas, electric, telephone, cable);

- c. Any act or omission of any agency or instrumentality of the State, other than the DPMC or DEP, including, without limitation, the Department of Community Affairs;
- d. Weather;
- e. Subsurface conditions of any type including, without limitation rock and underground utilities, whether or not such conditions were reasonably ascertainable to the Contractor at the time of bidding;
- f. Use of all or any portion the Project premises prior to completion of the Work to the extent that such use is permitted under the terms of the Contract;
- g. Delay in obtaining any permit or approval;
- h. Delay caused by the issuance of any court order, injunction or restraining order;
- i. Any delay which does not entitle the Contractor to an extension of the Contract Completion Time under Section 6.2.8 of these General Conditions; or
- j. Delay attributable to any other cause, other than a cause for which the State is legally restricted from enforcing a contractual “no damage for delay” clause under N.J.S.A. 2A:58B-3 or any other provision of law restricting or barring the enforcement of such clauses.

In interpreting this provision, the negligence or other wrongful conduct of others, including, without limitation, the Architect/Engineer, the CMF, any construction management firm and any other firm or person retained by the State shall not be imputed to the State. Further, to the extent that the Contractor is entitled to recover monetary damages for delay under this Contract, such recovery shall be limited to actual direct costs incurred on account of the delay, and shall not include profit or other markup on such costs, home office overhead calculated under the Eichleay formula or any other kind of consequential or indirect cost or damage, including but not limited to any alleged cost or damage under the total cost method, the modified total cost method, or productivity factors (costs for inefficiency based on industry productivity factors such as those provided by the Mechanical Contractors Association of America (MCAA) Factors Affecting Labor Productivity).

7.5.3 In the event of the failure of the Contractor to complete its work within the time stated in its Contract, the Contractor shall be liable to the State in the sum as set forth as liquidated damages in the Contract, for each and every calendar day that the Contractor fails to attain contract completion of the work. This sum shall be treated as liquidated damages to compensate for the loss to the State of the use of premises in a completed state of construction, alteration or repair, and for added administrative and inspection costs to the State on account of the delay; provided, however, that the said liquidated damages shall be in addition to other compensatory or consequential losses or damages that the State may incur by reason of such delay, such as, but not limited to, added costs of the Project and

the cost of furnishing temporary services, if any. Any such sums for which the Contractor is liable may be deducted by the State from any moneys due or to become due to the Contractor.

7.5.4 It is hereby understood and mutually agreed by and between the Contractor and the State that the start date in the Notice to Proceed, the dates of all required intermediate milestones, and the times for substantial and final completion, as specified in the Contract Documents, are essential conditions of this Contract.

7.5.5 The Contractor agrees that said work shall be executed diligently, at such rate of progress as will ensure full completion of the Work within the time specified. It is expressly understood and agreed, by and between the Contractor and the State, that the time for the completion of the Work herein is a reasonable time, taking into consideration the average climactic range and usual industry conditions prevailing in this locality. If the said Contractor shall neglect, fail or refuse to complete the Work within the time herein specified, or any proper extension thereof granted by the State, then the Contractor does hereby agree, as a part of the consideration for the awarding of its Contract, to pay the State the amount specified in section 7.5.3 above, as liquidated damages for loss of use of the Project as hereinafter set forth, for each and every calendar day that the Contractor may have exceeded the stipulated date in the Contract for substantially completing the Work.

7.5.6 It is further agreed that time is of the essence of each and every portion of this Contract and of the specifications wherein a definite and certain length of time is fixed for the performance of any act whatsoever; and where under the Contract an additional time is allowed for the completion of any Work, the new time limit fixed by such extension shall similarly be of the essence.

ARTICLE 8 - CLOSE-OUT

8.1 CLOSE-OUT PROCEDURES/FINAL PAYMENT

As part of the final completion procedures described in Article 7 and the requirements for payment as described in Article 9, the Contractor must complete all of the Close-out procedures as follows:

- a. Submit the "as-built" record documents as described in Article 4;
- b. Submit all operating and maintenance manuals, parts lists, repair source parts, and certificates as defined in 8.2 below;
- c. Provide the necessary training for operating systems and equipment as defined in 8.3 below; and
- d. Submit all guarantees as defined in 8.4 below.

8.2 OPERATIONS, EQUIPMENT AND MAINTENANCE MANUALS

8.2.1 The Contractor shall provide six (6) copies of all operating, equipment and maintenance manuals, and applicable warranties, as identified and described in the Contract Documents. The operating, equipment and maintenance manuals and warranties, including contact personnel, addresses and telephone numbers, must include a complete description of all systems and equipment and the method of operating and maintaining the equipment. These manuals must be submitted to the CMF for approval by the A/E for review and approval at the earliest date possible following substantial completion, but in all cases prior to final acceptance. Included within the manuals shall be a list of names, addresses and telephone numbers of all the Subcontractors involved in the installations and of firms capable of performing services for each mechanical item.

8.2.2 As a pre-condition to the Final acceptance of a facility for beneficial use, the Contractor shall provide a "throw-away" copy of operations and maintenance manuals to allow DEP staff to operate the equipment prior to receiving the hard bound copies required by this Contract.

8.3 TRAINING

The Contractor shall provide formal instruction for DEP-designated personnel, addressing the operation and maintenance of the facilities and all installed equipment for each operating system or major item of equipment or as otherwise specified. The operations and maintenance manuals shall be used as training materials. Unless otherwise accepted by the DEP Project Director, training course format shall be split equally between classroom instruction and field exercise. All classroom instruction may be videotaped by the DPMC. Classroom instruction may be supported by professionally made videotapes. If used, a copy of each professional video that was utilized shall be provided to the DEP at no cost for future training and reference.

8.4 GUARANTEE

8.4.1 The issuance of a final certificate for payment and/or partial or complete occupancy of the premises shall not be deemed an acceptance of Work not completed in accordance

with the Contract Documents. The issuance of a final certificate for payment and/or partial or complete occupancy of the premises shall not relieve the Contractor or its surety of liability with respect to any express or implied warranties or responsibility for faulty materials or workmanship.

8.4.2 The Contractor shall guarantee and warrant, in writing, the Work performed and all materials furnished under this Contract against defects in materials and/or workmanship. The Contractor shall be responsible for the value or repair of any damage to other Work or to the building premises resulting from the performance of the Contract.

8.4.3 The Contractor is responsible for the above-stated obligations for a period of one (1) year from the date established in 7.2.2 above. All guarantees, including bonds and registrations, required by the Contract Documents shall be in writing and delivered to the CMF with submission of the invoice for final payment.

8.4.4 Contractor shall, at its own expense and without cost to the State, promptly after receipt of written notice thereof, make good any defects in materials or workmanship which may develop during stipulated guarantee periods, as well as any damage to other Work caused by such defects or by repairs. Any other defects in materials or workmanship not discovered during the guarantee period shall be repaired and/or replaced at the Contractor's expense, and such shall be completed within a reasonable time after written notice is given to the Contractor.

8.4.5 Pursuant to the Contract Documents, certain permanent equipment, including elevators and HVAC systems, will have to be activated during construction of the Project to support construction operations. Despite any early activation during the construction of the Project, any and all equipment warranties must extend for the time periods required in the Contract Documents, starting at the date set forth in paragraph 7.2.2.

8.4.6 It is expressly acknowledged and agreed that the express and implied warranties and guarantees to which the State is entitled as well as all warranty and guarantee bonds issued by any surety, shall be in addition to and not in lieu of the State's right to seek recourse against the Contractor and the Contractor's surety for defective work.

ARTICLE 9 - PAYMENTS

9.1 INVOICES

9.1.1 Requests for payment under the Contract for materials delivered or services rendered require the proper completion and submittal of specific forms including, but not limited to, the following:

- a. DPMC Form 11/AR50-1 - DPMC Invoice;
- b. DPMC Form 11-2 - Monthly Estimate for Payment to Contractor;
- c. DPMC Form 11-2a - Certification of Prime Contractor;
- d. DPMC Form 11-2b – Certification of Subcontractor;
- e. Copies of Subcontractor(s) invoices;
- d. DPMC Form 11-3 - Prime Contractors Summary of Stored Materials;
- e. DPMC Form 11-3A - Agreement and Bill of Sale Certification for Stored Materials;
- f. Consent of Surety forms;
- g. Certified Payroll Records;
- h. Updated project schedule
- i. Any other information or documentation required by other provisions of the Contract documents.

9.1.2 The Contractor shall submit the completed request for payment on a monthly basis for all properly completed billable work to the CMF and at the address identified at the pre-construction conference.

9.1.3 One (1) original and one (1) copy of the request for payment packets shall be prepared and submitted unless otherwise specified.

9.1.4 No request for payment shall be deemed to be formally submitted and received for payment until all dollar amounts and completion percentages for each line item in the invoice has been determined and agreed upon by the State and the Contractor.

9.1.5 For the purpose of the State's Prompt Payment Act (N.J.S.A. 2A:30A-1 et seq.):

- a. A proper invoice shall be deemed to have been received by the State when it is received by the person or entity designated by the State to review and sign the invoice on the State's behalf at the address designated in the pre-construction conference for receipt of invoices. Receipt of an invoice by such person or entity shall commence the running of the 20-day period for formal approval and certification as provided under N.J.S.A. 2A:30A-2(a);
- b. The "billing date", as the term is used in N.J.S.A. 2A:30A-2, shall be the earlier of the date upon which an invoice for payment is approved for payment or twenty (20) days after the invoice is received, unless within such 20-day period the invoice is found to be incomplete or otherwise unacceptable and returned to the contractor, with a written explanation of deficiencies;

c. In the event that an invoice is found to be deficient and returned to the contractor, the “billing date” shall be calculated from the date that a corrected invoice is received.

d. Payment shall be considered to have been made on the date on which a check for such payment is dated;

e. Payment terms (e.g., “net 20”) offered by the contractor shall not govern the State’s obligation to make payment;

f. The following periods of time will not be included in the calculation of the due date of any contractor invoice:

(1) Any time elapsed between receipt of an improper invoice and its return to the contractor, not to exceed twenty (20) calendar days; or

(2) Any time elapsed between the State’s return of an improper invoice to the contractor and the State’s receipt of a corrected invoice.

9.1.6 The provisions of this Article 9 shall not govern the State’s payment obligations nor shall they supersede or modify any other contractual provision allowing the withholding of monies from the contractor to the extent that the contractor has not performed in accordance with the provisions of the contract. Nor shall this Article 9 govern the State’s payment obligations nor supersede or modify any other contractual provision governing Contractor claims for additional compensation beyond the base contract price and approved change orders.

9.2 INTEREST

9.2.1 Interest shall be payable on amounts due the contractor if not paid within thirty (30) calendar days after the billing date specified in the above subparagraph 9.1.5(b), as provided under the State’s Prompt Payment of Contractors and Subcontractors Act (N.J.S.A. 2A:30A-1, et seq.). Interest on amounts due shall be payable to the contractor for the period beginning on the day after the required payment date and ending on the date on which the check for payment is drawn.

9.2.2 Interest may be paid by separate payment to the Contractor, but shall be paid within thirty (30) calendar days of payment of the principal amount of the approved invoice.

9.2.3 Nothing in this Article 9 shall be construed as entitling the Contractor to payment of interest on any sum withheld by the State for any reason permitted under the Contract or applicable law, or on any claim for additional compensation, over and above sums due under the base Contract or approved change orders.

9.3 SCHEDULE OF VALUES AND FINAL PAYMENT

9.3.1 Unless otherwise directed, the Contractor shall furnish a schedule of amounts for Contract payments (Unit Schedule Breakdown,) of the total Contract price, showing the amount included therein for each principal category of the Work and for each Contractor and Subcontractor, in such detail as requested, to provide a basis for determining progress payments. The schedule, as approved, shall be used only as a basis for the Contractor's estimates for progress payments, and approval by the CMF does not constitute acceptance of the allocability and allowability of costs to a specific element of Work. The Contractor is cautioned that no payment requests shall be approved until the Unit Schedule Breakdown has been approved in writing by the CMF.

9.3.2 The State will make progress payments monthly as the Work proceeds based upon the Unit Schedule Breakdown.

9.3.3 All material and Work paid pursuant to progress payments shall thereupon become the sole property of the State. This provision shall not be construed as relieving the Contractor from the sole responsibility for the protection of all material and Work upon which payments have been made for the restoration of any damaged work, or as waiving the right of the State to require the fulfillment of all of the terms and conditions of the Contract.

9.3.4 Following completion and acceptance of all work, the amount due the Contractor under this Contract shall be paid only upon satisfactory completion, by the Contractor, of all Contract close-out requirements, completion of a State audit on all Contract values and payments, and after the Contractor has furnished the State with a release of claims against the State, arising by virtue of this Contract, other than claims in stated amounts as may be specifically excepted by the Contractor from the release.

9.3.5 If for any reason the Contractor refuses final payment, the Project may be closed out by the State by the processing of a Final Contract Acceptance certification. The lack of such certification shall not toll the limitations period applicable to Contractor claims against the State.

9.3.6 In addition to other warranties required by provisions of the Contract and specifications, the Contractor warrants that title to all Work, materials and equipment covered by an application for payment will pass to the State free and clear of all liens, claims, security interests or encumbrances, either upon incorporation into the construction or upon receipt of payment to the Contractor, whichever occurs first. This provision shall not be construed as relieving the Contractor from sole responsibility for the care and protection of materials and work upon which payments have been made, or for the restoration of any damaged work, or as a waiver by the State of its rights to require fulfillment of all terms of the Contract.

9.3.7 By recommending approval of any invoice, neither the A/E nor the CMF shall be deemed to represent that it has made exhaustive or continuous on-Site inspections to check the quality or quantity of the Work, or that it has reviewed the construction means, methods, techniques, sequences or procedures, or that it has made any examination to ascertain how and for what purpose the Contractor has used the moneys previously paid. The payment of an invoice does not constitute an acceptance of the Work. The State reserves the right to further inspect the Work and to withhold retainage and any additional funds required to pay for any corrective action for non-conforming work.

9.3.8 If any corporation licensed to do business in New Jersey shall be or become delinquent in the payment of taxes, assessments or fees due the State, unless under an active appeal process or any final judgment in the State's favor against the Contractor, the State may, in accordance with N.J.S.A. 54:49-19 or other applicable law withhold moneys due the said corporation for the purpose of assuring the payment to the State of such taxes, assessments, fees or judgment.

9.4 CERTIFICATION OF PAYMENTS TO SUBCONTRACTOR

Pursuant to N.J.S.A. 52:32-40, 41 and N.J.S.A. 2A:44-148; the Contractor shall submit a Certification of Prime Contractors form and a Certification of Subcontractor form for each Subcontractor identified in the Unit Schedule Breakdown, as part of the submission for each invoiced progress payment.

9.5 STORED MATERIALS

9.5.1 Unless specifically allowed in the Contract Documents, all materials and equipment must be delivered and installed or stored on the Site prior to payment for such material or equipment.

9.5.2 The DEP may at its discretion allow payment for equipment stored off Site provided that the following has occurred:

- a. The DEP Project Director has approved the Contractor's written request;
- b. The equipment has been properly stored in an approved location;
- c. The Contractor has established the State's title to the specific equipment;
- d. The Contractor has provided sufficient proof of insurance for the materials, equipment and the storage facility;
- e. The Contractor has submitted a release of liens on said stored equipment;
- f. The Contractor has submitted a statement agreeing to assume all costs for storage of material and equipment off Site, including, if required by the DPMC, the cost of storing such material and equipment in a bonded warehouse; and
- g. The Contractor furnishes the "Prime Contractor's Summary of Stored Materials" and "Agreement and Bill of Sale Certification for Stored Materials," forms respectively.

9.6 ALLOWANCES

9.6.1 The Contractor shall purchase the allowance items as directed by the DEP Project Director on the basis of the lowest acceptable quote from at least three competitive offers or as a negotiated cost subject to DEP and DPMC approval. If the actual cost of the allowance items is more or less than the stipulated allowance, the Contract price may be adjusted accordingly. The adjustment in Contract price shall be made on the basis of the actual purchase cost without additional charges for overhead, profit, bond

premium or any other incidental expenses. The cost of installation of the "allowed materials," unless otherwise specified, is to be included as the responsibility of the Contractor in whose Contract the allowance is included, and the Contractor installing such allowance items shall not be entitled to additional payment for such installation.

9.6.2 Unless otherwise provided in the Contract Documents:

- a. These allowances shall cover the Contractor's true costs, including credit for any trade discount, of the materials and equipment required by the allowance, delivered at the Site, including all applicable taxes;
- b. The Contractor's costs for unloading and handling, labor, installation costs, overhead, profit and other expenses reasonably required in connection with such allowance items shall be included in the Contract sum and not as part of the allowances.

9.7 RETAINAGE

9.7.1 In making progress payments for Contract work completed, the State will retain ten percent (10%) of the approved invoice amount until final acceptance and completion of all work covered by the Contract.

9.7.2 The Contractor may, after 50% (fifty percent) of the Contract work is in place, and if the Work is proceeding on schedule, apply for a reduction in the amount retained by the State for the duration of the Contract. Such application must be in writing and accompanied by documentation granting formal consent of surety to the reduction in retainage request. If the DPMC determines that the Contractor's performance has been satisfactory and that the reduction is warranted and appropriate, the State may, with the next progress payment, release any portion of the accumulated retainage in excess of five percent (5%) of the Work in place and retain an amount equal to five percent (5%) of the Work in place for the duration of the Contract. If progress of the Work is not maintained in accordance with the approved schedule, the DEP Project Director may elect to re-institute retainage of ten percent (10%) of the Work in place for the duration of the Contract.

9.7.3 Withholding Payment for Non-Delivery of Data:

- a. If technical data such as "as-built" drawings, reports, spare parts lists, repair parts lists, or instruction books (including additional and maintenance manuals), or any part thereof, are not delivered within the time specified by this Contract or are deficient upon delivery, the DEP Project Director has the discretion to withhold from each invoice a percentage (in addition to any other retainage required by the Contract) of the Contract price in accordance with the following table:

When total contract price is: Percentage to be withheld is:

Less than \$250,000.	10%
\$250,000.01 through \$1,000,000	5.0%
Over \$1,000,000	2.0%

- b. The withholding of any sums pursuant to this article shall not be construed as, or constitute in any manner, a waiver by the State of the Contractor's obligation

to furnish the data required under this Contract. In the event the Contractor fails to furnish these items, the State shall have those rights and remedies provided by law and pursuant to this Contract, in addition to, and not in lieu of, the sums withheld in accordance with this article.

9.8 MISCELLANEOUS

9.8.1 Disputes regarding nonpayment of a Contractor's invoice under this Article 9 may be submitted to non-binding Alternative Dispute Resolution (ADR) upon mutual agreement of the State and the Contractor. In such event, the State and the Contractor shall share equally the fees and expenses of the selected mediator, arbitrator, umpire or other ADR neutral. Provided, however, that nothing herein shall be construed, in whole or in part, as a waiver, release or modification of the provisions of the New Jersey Contractual Liability Act, N.J.S.A. 59:13-1, et seq., which governs claims against the State.

9.8.2 A Contractor not paid sums due under an approved invoice within thirty (30) days of the billing date may suspend performance without penalty for breach of contract, but only after providing the State with seven (7) days written notice of non-payment, and only in the event that the State fails to furnish the Contractor, within that seven-day period, a written statement of the amount withheld and the reasons for the withholding. Nothing herein shall be construed to excuse the Contractor's nonperformance, or to limit the State's rights and remedies relating to such non-performance, with regard to any monies withheld from the Contractor upon the proper notice provided under this Article 9, or with regard to any Contractor claim disputed by the DPMC.

ARTICLE 10 - CHANGES IN THE WORK

10.1 CHANGES IN THE WORK

10.1.1 The DPMC may at any time, issue a written Change Order which shall direct a Change in the Work within the general scope of the Contract, including, but not limited to, changes:

- a. In the plans and/or specifications;
- b. In the method or manner of performance of the Work;
- c. In the State-furnished facilities, equipment, materials, services, or site; or directing acceleration in the performance of the Work; and/or
- d. In the time for the completion of the Work.

10.1.1.1 The Contractor agrees that immediately upon discovering, uncovering or encountering any conditions it considers a changed condition, it will immediately notify the A/E, DEP and CMF prior to continuing work or covering up the changed condition to allow the A/E, DEP and CMF the opportunity to assess and verify the potential changed condition. Should the Contractor fail to immediately notify the A/E, DEP and CMF and continues work or covers the condition, that failure to notify may be grounds for rejection of any claim or request for Change Order.

10.1.2 Change Orders

10.1.2.1 The Contractor agrees to prepare and submit, within ten (10) calendar days of encountering any conditions it considers a change, or upon receiving official notice of a proposed change or written direction to proceed with a change, a current DPMC form entitled "Contractor Change Order Request," to the DEP Project Director. The Contractor shall submit an original of the form. Failure to submit a timely form may be grounds for rejection of the request for Change Order, at the DEP Project Director's discretion.

10.1.2.2 All requests for Contract time extensions must be submitted in accordance with the requirements set forth in Articles 6 and 7, accompanied by copies of the current approved progress schedule and copies of a proposed progress schedule detailing the incorporation of the changed work and the effects of such incorporation on progress. Failure to provide all required information shall be grounds for rejection of the request.

10.1.2.3 The State will only consider a contract duration extension Change Order request arising from Changes in the Work, if that change is proven by the Contractor to have caused a delay in the completion of the Project. When the Contract duration is increased as a result of a change, the resulting change in Contract amount will include the costs of extended performance, computed in accordance with the terms of this Section, and no further consideration of such costs arising from the specific modification will be given.

10.1.2.4 Every Change Order request submitted by the Contractor shall furnish a price breakdown, which shall cover all work involved in the change whether such work was deleted, added or changed and shall be in sufficient detail to permit an analysis of all material, labor, equipment, subcontract, overhead costs and profit. Any amount proposed for subcontracts shall be supported by an equally detailed breakdown. In addition, if the request includes a time extension, a justification (see Article 6.2.8(a)) shall also be

furnished. The request, together with the price breakdown and time extension justification, shall be furnished by the date specified by the DEP Project Director.

10.1.2.5 The following rates shall apply in computing overhead (indirect costs) and profit for Change Orders that do not exceed \$25,000. The percentages shall be applicable for deleted work as well as additional work. When a change consists of both added and deleted work, the applicable percentages shall be applied to the net cost or credit. In any event, the percentages shall not exceed the following:

- a. Overhead will be the sum of:
 - (1) fifteen percent (15%) of direct labor costs. NOTE: For the purpose of this article, the term "direct labor" shall include all foremen (identified by name and not included in the Project as the full-time superintendent or full time foreman as required elsewhere in the contract documents), equipment operators and skilled, semi-skilled and common laborers directly assigned to the specified operation. The term "direct labor costs" shall consist of the Contract or actual payroll rate of wage per hour and fringe benefits paid for each and every hour that such employees are actually engaged in the performance of the Work.
 - (2) fifteen percent (15%) of direct material costs. NOTE: For the purpose of this article, the term "direct material costs" shall consist of the actual costs of the materials including applicable tax and transportation charges.
- b. For rented equipment, an hourly rental rate will be used which will be determined based upon the monthly rental rates in the current edition of the Rental Rate Blue Book for Construction Equipment (Rental Book) and dividing it by 176. An allowance will be made for operating costs for each and every hour the equipment is actually operating in accordance with the rates listed in the Rental Book. The Contractor will be allowed only 65% (sixty-five percent) of the rental rate on Contractor-owned equipment.
- c. Bond premiums and payroll taxes, if applicable, will be allowed at actual cost. The Contractor shall submit from the surety to DEP Project Director a letter for the bond premiums.
- d. The Contractor's profit on Subcontractor's work will be six percent (6%) of the Subcontractor's costs. Subcontractor indirect costs will be computed in the same manner as for the Contractor. The Contractor agrees to incorporate this article in each of its subcontracts. NOTE: When more than one tier of Subcontractor exists, for the purpose of markups, they shall be treated as one Subcontractor.
- e. A profit of six percent (6%), where profit is allowable by the terms of the applicable Contract provision, shall be added to the Contractor's total cost. Indirect costs shall not be duplicated in direct costs.

10.1.2.6 For Change Orders in excess of \$25,000 the maximum allowable percentages of 15% overhead and 6% profit applies unless negotiated lower based upon the nature, extent and complexity of the Work involved.

10.1.2.7 The DEP Project Director, in order to avoid delays in the progress of work or when in the best interests of the State, has the discretion to direct the Contractor, in

writing, to proceed with work claimed by the Contractor to be extra work , and/or to accelerate its work without a prior agreement on entitlement or costs. Such direction shall be in the form of a Letter of Direction. The Contractor may submit a claim for evaluation by the DEP Project Director, for costs or for time on account of such work and/or acceleration on the form entitled "Contractor Change Order Request," completed in sufficient detail and in accordance with this article within ten (10) calendar days after receipt of the Letter of Direction. Nothing in this article shall excuse the Contractor from proceeding with the Work identified in the Letter of Direction and all other Contract Work. Issuance of a Letter of Direction under this article shall not be intended nor construed as an admission or acknowledgment by the State that the Contractor is entitled to additional compensation and/or time on account of such Work and/or acceleration.

10.2 **ACCELERATION**

The DEP Project Director may order and direct the Contractor to accelerate its Work at any location(s) by increasing its forces, working overtime and/or working on Saturdays, Sundays, and holidays. If acceleration is required by the State, and not due to any delays on the part of the Contractor, the Contractor will be reimbursed for additional costs.

ARTICLE 11 - CLAIMS AND DISPUTES

11.1 CONTRACTOR CLAIMS

11.1.1 Any claims made by a Contractor against the State for damages, extra costs or any other claim made pursuant to the contract are governed by and subject to the New Jersey Contractual Liability Act, N.J.S.A. 59:13-1 et seq., as well as all the provisions in this Contract.

11.1.2 Upon presentation by the Contractor of a request in writing, the DPMC and the DEP may review any decision or determination of the State, the CMF or the Architect/Engineer as to any claim, dispute or any other matter in question relating to the execution or progress of the Work or the interpretation of the Contract Documents. Consistent with the intent of this Contract, the DPMC may schedule a conference for the purpose of settling or resolving such claims, disputes or other matters. Where such a conference is conducted, the Contractor, the CMF and/or the Architect/Engineer shall be afforded the opportunity to be heard on the matter in question. Following review of the Contractor's request, the DPMC and the Contractor may settle or resolve the disputed matter, provided however that any such negotiations, conferences, settlement or resolution shall be subject to all requirements imposed by law, including where applicable, the New Jersey Contractual Liability Act (N.J.S.A. 59:13-1 et seq.). The DPMC's participation in any effort to negotiate, settle or resolve any such claim or dispute with the Contractor shall not operate to toll or extend the time limitations for notice or suit under the New Jersey Contractual Liability Act.

11.2 MUTUAL RIGHTS AND RESPONSIBILITIES OF ALL CONTRACTORS, THE CONSTRUCTION MANAGEMENT FIRM AND THE ARCHITECT/ENGINEER

11.2.1 Any Contractor or the CMF or the A/E which by its own acts, errors or omissions, damages or unnecessarily delays the Work or otherwise causes damage to the State, any other Contractor or the CMF or A/E, shall be directly responsible to the aggrieved party or parties, for all costs and expenses incurred due to any such delays and/or damages whether by settlement, compromise or arbitration or judgment.

11.2.2 Any Contractor damaged by the actions of another Contractor or the CMF or A/E shall have a direct right to recovery against the party causing such damages, but shall not have a right to recover such damages against the State.

11.2.3 In addition, the party responsible for causing such damages agrees to defend, indemnify and save harmless the State from all such claims and damages. Nothing contained in this paragraph shall be construed to relieve the responsible party from any liability or damage sustained on account of such acts, errors or omissions.

11.2.4 The State shall not be held vicariously liable to any Contractor for any damages or extra costs caused by any acts or omissions by another party including but not limited to actions of the CMF or A/E as specified in the above paragraph. The Contractor's exclusive remedy shall be against the party directly responsible for causing such damages or extra costs.

ARTICLE 12 - TERMINATION/SUSPENSION

12.1 SUSPENSION OF THE WORK / STOP WORK

12.1.1 If the Contractor fails to correct defective work or persistently fails to carry out the Work in accordance with the Contract Documents, or if the State determines that it is in the best interest of the Project to do so, the DEP Project Director, with the approval of the DPMC, may order the Contractor to stop the Work, or any portion thereof, until the cause for such order has been eliminated and the DPMC provides written notice to the Contractor that the stopped Work may resume.

12.1.2 DPMC shall have the right to defer the beginning or to suspend the whole or any part of the Work herein contracted to be done whenever, in the opinion of the DPMC, it may be necessary or expedient for the State to do so.

12.2 TERMINATION FOR CAUSE

12.2.1 If the Contractor persistently or repeatedly refuses or fails to supply enough properly skilled workers or proper materials so as to avoid or eliminate delays in the orderly progress of the Work in accordance with the approved schedule; or if the Contractor fails to make prompt payment to any Subcontractor or for materials or labor; or persistently disregards laws, ordinances, rules, regulations or orders of any public authority having jurisdiction; or if the Contractor is guilty of a material breach of a provision of the Contract Documents or otherwise fails to carry out the Work in accordance with the Contract Documents, then the State may, without prejudice to any other right or remedy, and after giving the Contractor and its surety three (3) working days written Notice to forthwith address such breach and default with diligence and promptness, terminate the employment of the Contractor by the issuance of a written Notice to that effect to the Contractor and its surety, should the Contractor fail to comply with the demands of the original above mentioned Three Day Notice.

12.2.2 Upon such termination, the State may take possession of the Site and of all the materials, equipment, and tools on the Site and of any materials stored off Site paid for by the State, and may finish the Work by whatever method the State may deem expedient. In such case, the Contractor shall not be entitled to receive any further payment until the Work is finished.

12.2.3 In the event of termination for default, the surety shall either complete the principal's work or finance the completion of the Work. The surety shall not have the right to do nothing. In the event of the surety's breach of its obligations to the State, the surety shall be subject to all available damages under the law, including but not limited to debarment and the penalties imposed by New Jersey's Consumer Fraud Act.

12.2.4 Within seven (7) calendar days following receipt of Notice of Termination by the surety, the surety shall submit in writing its intention to satisfy its bond obligation to the

State as obligee, and to explain its plan to complete the Work, tender a completing Contractor or finance the completion of the Work.

12.2.5 If the surety elects to take over the Work and complete same or to tender a completing Contractor, it must furnish notice of its intent to do so in writing over the signature of an authorized representative and such notice shall be served upon the DPMC within seven (7) calendar days after service upon the surety of the Notice of Termination. This document shall identify the Contractor to perform this work.

12.2.6 If the surety elects to satisfy its bond obligation by financing the completion of the Work, in lieu of taking over same, the surety and the State shall enter into an agreement, within thirty (30) days of the termination Notice, setting forth the details of the payments to be made by the surety. All current obligations for labor and materials incurred and outstanding by the defaulting Contractor on this Project shall be paid by the surety without delay, subject to allowance of reasonable time to verify such claims by the surety.

12.2.7 If the surety fails to satisfy its bond obligations within the time frames established above, the State may undertake the completion of the Project in any manner deemed appropriate. In that circumstance, the surety shall not be relieved of any of its payment and performance bond obligations.

12.2.8 If the unpaid balance of the Contract sum exceeds the cost of finishing the Work (including but not limited to liquidated damages for delays and all other remaining damages sustained by the State originating from such breach of Contract), such excess shall be paid to the Contractor. If such costs exceed the unpaid balance, the Contractor and its surety shall be obligated to pay the difference to the State promptly upon receipt of billing from the State, and this obligation shall survive the termination of the Contract.

12.3 STATE'S RIGHT TO COMPLETE THE WORK

12.3.1 Alternatively, should the Contractor fail or refuse to correct its breach and default after receiving the required notice as provided under Section 12.2 hereof, the State, in lieu of terminating the Contractor's employment, may provide for the correction and completion of all remaining Work by other means, and deduct all costs associated with such correction and completion from any undisbursed balance of funds (including earned retainage) remaining under the Contract. Such deduction may be documented by issuance of one or more deductive change orders. The State's correction or completion of Work under this paragraph shall not operate to waive, release or diminish the liability of the Contractor and its surety to the State for any breach or default by the Contractor.

12.4 TERMINATION FOR CONVENIENCE

12.4.1 The State may, at any time, terminate the Contract in whole or in any part for the State's convenience and without cause when the State in its sole discretion views termination to be in the public interest.

12.4.2 Upon receipt of an order of Termination for Convenience, the Contractor shall not proceed with any item of work which is not specified in the Order of Termination. The Contractor shall complete all items of work specified in the termination order. Such work shall include punch list items and all work necessary to ensure the safety of the public, to properly secure existing work already constructed or partially constructed and to secure the Project Site. This work so ordered shall be performed in accordance with the Contract

Documents, and may include items of work not in the original Contract. The Work performed shall be considered substantially complete upon completion and acceptance of all items of work specified in the Order, except punch list items. After completion of the punch list items and all documents required by the Contract, the Contract shall terminate upon issuance of a Final Certificate and payment. The State reserves the right to declare in default a Contractor who fails to carry out the conditions set forth in an Order of Termination for Convenience.

12.4.3 When the State orders termination of the Contract for Convenience, all completed items of work as of that date will be paid for at the Contract prices.

12.4.3.1 Payment for partially completed work will be paid for at agreed prices.

12.4.3.2 Payment for new items, if any, will be made either at agreed prices or in accordance with Article 10.

12.4.3.3 Materials obtained by the Contractor for the Work but which have not been incorporated therein may, at the option of the State, be purchased from the Contractor at actual cost delivered to a prescribed location, or otherwise disposed of as mutually agreed.

12.4.4 Within sixty (60) days of the effective termination date, the Contractor shall submit claims for additional costs actually incurred, not covered above or elsewhere in the Contract. Such claims may include reasonable mobilization costs, overhead expenses attributable to the Work performed, Subcontractor costs not otherwise paid for, actual idle labor costs if Work is stopped in advance of the termination date. The State will not compensate the Contractor for costs prohibited under provisions of the Contract and/or anticipated profits on work not performed.

12.4.5 If the State terminates the Contractor for cause as provided under Article 12.2 of the General Conditions, and if a court of law subsequently determines such termination for cause to have been undertaken without lawful justification, then such termination shall be deemed a termination for convenience governed by this Article 12.4. In that event, recovery by the Contractor and/or the Contractor's surety shall be limited to those costs which are recoverable following a termination for convenience under this Article 12.4.

ARTICLE 13 – OTHER REQUIREMENTS

13.1 PREVAILING WAGE

13.1.1 The Contractor shall comply with the New Jersey Prevailing Wage Act Laws of 1963, Chapter 150, (N.J.S.A. 34:11-56.25 et seq.) and all amendments thereto, and this act is hereby made a part of every Contract entered into on behalf of the State of New Jersey through the DPMC, except those Contracts which are not within the contemplation of the Act. Provisions of the Act include the following stipulations and requirements:

a. All workers employed in the performance of every Contract in which the Contract sum is in excess of \$2,000 and to which the DPMC is a party shall be paid not less than the prevailing wage rate as designated by the Commissioner, Division of Labor or his or her duly authorized representative.

(1) The Contractor performing public work for the DPMC and which is subject to the provisions of the Prevailing Wage Act, shall post the prevailing wage rates for each craft and classification involved as determined by the Commissioner, Division of Labor. This posting shall include the effective date of any changes thereof, and shall be displayed in prominent and easily accessible places at the Site of the Work or at such place or places as are used by the Contractor/Subcontractor to pay workers' wages.

(2) At the time of the bid due date, the Bidder and any Subcontractors identified by the Bidder must be registered in accordance with “The Public Works Contractor Registration Act” (N.J.S.A. 34:11-56.48 et seq.) All questions regarding registration shall be addressed to:

Contractor Registration Unit
New Jersey Department of
Labor and Workforce
Development
Division of Wage & Hour
Compliance P O Box 389
Trenton NJ 08625-
0389
[https://www.rohrerbus.com/new-jersey-bus-sales/FAX: 609-633-8591](https://www.rohrerbus.com/new-jersey-bus-sales/FAX:609-633-8591)

b. In the event it is found that any worker, employed by any Contractor covered by any Contract in excess of \$2,000 for any public work to which the DPMC is a party, has been paid a rate of wages less than the prevailing wage required by such Contract, DPMC may terminate the Contractor's right to proceed with the Work, or such part of the Work as to which there has been failure to pay required wages, and may otherwise execute the Work to completion.

- c. In the event that any Subcontractor retained by a Contractor on any Contract in excess of \$2,000 for any public work to which the DPMC is a party, has been paid a rate of wages less than the prevailing wage required by such Contract, DPMC may terminate the Contractor's right to proceed with the Work, or such part of the Work as to which there has been failure to pay required wages, and may otherwise execute the Work to completion or may require that the Contractor immediately substitute a new Subcontractor at the costs set forth in the Contract.
- d. Nothing contained in the Prevailing Wage Act shall prohibit the payment of more than the prevailing wage rate to any worker employed on a Project.
- e. The Contractor shall, as a condition of subcontract with any tier Subcontractor, require compliance with this section as a condition of Subcontract.
- f. The State may audit the Contractor's conformance with the Prevailing Wage Act. If the result of such audit determines that the Contractor has not complied with the Prevailing Wage Act then such Contractor shall be responsible for the cost of this audit.

13.2 PATENTS

13.2.1 The Contractor shall hold and save the State and its officers, agents, servants, and employees harmless from liability of any nature or kind, including cost and expenses for or on account of any patented or non-patented design, devise, invention, process, article or appliance manufactured or used in the performance of the Contract, including its use by the State, unless otherwise specifically stipulated in the Contract Documents.

13.2.2 License and/or royalty fees for the use design, devise, invention, process, article or appliance which is authorized by the State must be reasonable, and paid to the holder of the patent or his or her authorized licensee directly by the State and not by or through the Contractor.

13.2.3 If the Contractor uses any design, devise, invention, process, article or appliance covered by letters, patent or copyright, it shall provide for such use by suitable agreement with the State of such patented or copyrighted design, device or material. It is mutually agreed and understood that, without exception, the Contract prices shall include all royalties or costs arising from the use of such design, devise, invention, process, article or appliance in any way involved in the Work.

13.2.4 The Contractor and/or its surety shall indemnify and save harmless the State from any and all claims for infringement by reason of the use of such patented or copyrighted devise, invention, process, article or appliance, or any trademark or copyright in connection with Work performed under this Contract, and shall defend and indemnify the State for any cost, expense or damage which it may be obliged to pay by reason of such infringement at any time during the execution of the Work or after the completion of the Work. This section shall survive the termination of the Contract.

13.3 RIGHT TO AUDIT

13.3.1 The State reserves the right to audit the records of the Contractor in connection with all matters related to its Contract. The Contractor agrees to maintain its records in accordance with "Generally Accepted Accounting Principles," for a period of not less than

five (5) years after receipt of final payment. All charges must be supported by appropriate documentation, including, but not limited to canceled checks. All records shall be made available to the New Jersey Office of the State Comptroller or other State audit agency upon request and at no cost to the State.

13.3.2 The Contractor shall maintain all documentation related to products, transactions or services under this contract for a period of five years from the date of final payment. Such records shall be made available to the New Jersey Office of the State Comptroller or other State audit agency upon request and at no cost to the State.

13.3.2 The Contractor shall develop, maintain and make available to the DPMC on request such schedule of quantities and costs, progress schedules, payrolls, reports, estimates, Change Orders, all original estimates, takeoffs and other bidding documents, all Subcontractor and supplier Contracts and changes, all records showing all costs and liabilities incurred or to be incurred in connection with the Project (including all Subcontractor and supplier costs), all payment records and all records showing all costs incurred in labor and personnel of any kind, records and other data as the State may request concerning work performed or to be performed under this Contract.

13.3.3 The Contractor acknowledges and agrees that no claim for payment which is premised to any degree upon actual costs of the Contractor shall be recognized or payable by the State except and to the extent that such actual costs are substantiated by records required to be maintained under these provisions.

13.3.4 The Contractor acknowledges and agrees that its obligation to establish, maintain and make available records and the State's right to audit as delineated herein shall extend to actual costs incurred by Subcontractors in performing work required under the Contract Documents. The Contractor shall require in each subcontract that the Subcontractor establish, maintain and make available to the State all records as defined and delineated herein, relating to all work performed under the Subcontractor including work performed by a sub-Subcontractor.

13.4 INSURANCE

13.4.1 Insurance To Be Carried By The Contractor:

The Contractor shall obtain and maintain, at its expense and for the duration of the contract, minimum insurance coverage set forth below. By requiring such minimum insurance, the State of New Jersey shall not be deemed or construed to have assessed the risk that may be applicable to the Contractor under this contract. The Contractor shall assess its own risks and if it deems appropriate and/or prudent, maintain higher limits and/or broader coverage. The Contractor is not relieved of any liability or other obligations assumed or pursuant to the Contract by reason of its failure to obtain or maintain insurance in sufficient amounts, duration or types.

a Commercial General Liability:

(1) Commercial General Liability (CGL)-ISO occurrence form CG001 or a substitute form providing a minimum coverage of \$2,000,000 per occurrence for bodily injury liability and \$2,000,000 per occurrence for property damage liability and shall cover liability arising from:

- Premises/Operations

- Independent Contractors
 - Products/Completed Operations
 - Personal and Advertising Injury
 - Liability assumed under an insured contract (including defense cost assumed)
- (2) The State of New Jersey shall be included as an additional insured under the CGL using ISO additional insured endorsement CG 20 10 and CG 20 37 or a substitute providing equivalent coverage, which endorsement shall include coverage for the State of New Jersey arising out of the completed operations of the contractor, and which coverage shall be maintained in effect for the benefit of the State of New Jersey for a period of three (3) years following the completion of the work specified in section 7.3 of this contract. Additional Insured coverage as required in this subparagraph shall apply as primary insurance with respect to any other insurance or self-insurance programs afforded to the State of New Jersey.
- (3) The CGL general aggregate shall apply separately to this project using ISO CG 2503 form – designated construction projects(s) General Aggregate Limit.
- (4) There shall be no endorsement or modification of the CGL limiting the scope of coverage for liability arising from explosion, collapse or underground property damage.
- (5) If not included in the policy form the CGL policy must be endorsed with a separation of insureds (severability of interests) endorsement.
- (6) CGL policy must provide or be endorsed (ISO form CG 24 04) to provide for waiver of subrogation.

b Business Automobile Liability:

- (1) Contractor and subcontractors shall maintain business auto liability insurance and such insurance shall cover liability arising out of any auto (including owned, hired and non-owned autos).
- (2) The limits of liability shall be not less than \$1,000,000 per occurrence for both bodily injury and property damage liability.
- (3) Business Automobile coverage shall be written on ISO form CA 00 01 or a substitute form providing equivalent liability coverage. If necessary, the policy shall be endorsed to provide contractual liability coverage equivalent to that provided in the 1990 and later additions of CA 00 01.
- (4) If required by law, the business auto policy shall be endorsed to provide pollution liability coverage equivalent to that provided under the ISO pollution liability broadened coverage for covered autos form CA 99 48 and the Motor Carrier Act endorsement (MCS 90) shall be attached.

- (5) Waiver of Subrogation -- Contractor waives all rights against the State of New Jersey for recovery of damages to the extent these damages are covered by the business auto liability insurance obtained by Contractor pursuant to Paragraph 2.0 of this Agreement.
- c Workers Compensation: Workers Compensation Insurance applicable to the laws of the State of New Jersey and other State or Federal jurisdiction is required to protect the employees of the Contractor or any Subcontractor who will be engaged in the performance of this Contract. This insurance shall include employers' liability protection with a limit of liability not less than \$500,000.
- d Umbrella Liability: Contractor must maintain an Umbrella Liability Policy excess of the Commercial General Liability, Automobile Liability and Employer Liability coverage.
 - (1) The coverages of the umbrella policy must be as broad as the primary policies covered by this policy and include a “drop-down” provision if the primary coverage becomes impaired or exhausted.

13.4.2 Insurance To Be Carried By The State of New Jersey:

- a Builders Risk Insurance: Unless otherwise provided in this agreement the State of New Jersey shall provide and maintain, in a company or companies lawfully authorized to do business in the jurisdiction which this project is located, Builders Risk Insurance in the amount of the initial contract amount as well as subsequent modifications for the entire project at the site on a replacement cost basis.
 - (1) The Builders Risk coverage shall be on an “All Risk of direct physical loss or damage” or equivalent policy form and include theft, earthquake, flood, temporary structures, demolition and increased cost of construction, architects fees and expenses.

Also the insurance must include coverage for Equipment Breakdown Coverage (a.k.a. Boiler & Machinery) which shall cover insured Equipment during installation and testing. The Builders Risk insurance shall include the interest of the State of New Jersey, the general Contractor, subcontractors and sub-tier contractors in the project.
 - (2) The Builders Risk Policy shall cover all materials equipment and supplies, assemblies and furnishings intended for specific installation in the project while located at the site. The policy will cover portions of the work off site and portions of the work in transit subject to the policy sub-limits for these coverages.
 - (3) Waivers of Subrogation -- The State of New Jersey and Contractor waive all rights against (1) each other and any of their subcontractors, sub-subcontractors, agents and employees and (2) the Architect/Engineer, Architect/Engineer’s Consultants, and any of their subcontractors, Sub-subcontractors, agents and employees for damages caused by fire or other causes of loss to the extent covered by the

Builders Risk insurance or any other property insurance applicable to the work.

- (4) The Builders Risk policy will provide for a waiver of subrogation against all interested parties covered by the policy but only to the extent the loss is covered by the policy.
- (5) The above insurance shall apply only to the work described in this contract, and shall not apply to alterations, repairs, maintenance and installations of systems, equipment and other items of work which do not result in creating additional habitable space. This insurance shall not protect against damage or loss to any of the Contractor's or Subcontractor's tools, equipment, scaffolding, staging towers or forms and Contractor's materials stored on Site which are not part of the construction Project,. It is understood that the Contractor will, at its own expense, carry all insurance which may be required to provide the necessary protection against such loss or damage herein described which shall contain a waiver of any right of subrogation against the State of New Jersey.
- (6) Deductible Provisions -- The insurance protection described herein may contain a deductible clause. The State of New Jersey agrees to bear the cost of all deductibles of the Builders Risk Policy.
- (7) Loss Reporting and Loss Adjustment – The Contractor will receive a Loss Reporting Form whenever Builders’ Risk Insurance is written. This form includes appropriate loss reporting instructions. In the event of loss, the Contractor shall immediately notify the State of New Jersey, DPMC, in writing, and take any other appropriate steps as may be required under the standard builders' risk insurance policy in effect. Upon the occurrence of any loss or damage prior to the acceptance of the building by the State, the Contractor shall, at the State's option, replace and repair the damaged work as originally provided in the drawings and specifications at no additional compensation to that provided in the original Contract.
- (8) Status Trustee for Loss Adjustment -- All losses will be adjusted with, and payable to, the State of New Jersey, as trustee for the insured as their interests may appear. The Contractor shall be named jointly with the State in all policies of insurance, all of which shall be open to inspection by the State.
- (9) This provision shall not relieve the Contractor from its obligation to complete, according to plans and specifications, the Project covered by the Contract, and the Contractor and its surety shall be obligated to full performance of the Contractor's undertaking.

13.5 ASSIGNMENT OF ANTITRUST CLAIMS

13.5.1 The Contractor recognizes that in actual economic practice, overcharges resulting from antitrust violations are in fact usually borne by the ultimate purchaser. Therefore,

and as consideration for executing this Contract, the Contractor, acting herein by and through its duly authorized agent, hereby conveys, sells, assigns, and transfers to the State of New Jersey, for itself and on behalf of its political subdivisions, instrumentalities, and public agencies, all right, title and interest to all claims and causes of action it may now or hereafter acquire under the antitrust laws of the United States or the State of New Jersey, relating to the particular goods or services purchased or acquired by the State of New Jersey or any of its political subdivisions or public agencies pursuant to this Contract.

13.5.2 In connection with this assignment, the following are the express obligations of the Contractor:

- a. The Contractor will take no action which will in any way diminish the value of the rights conveyed or assigned hereunder.
- b. The Contractor will advise the Attorney General of New Jersey and DPMC:
 - (1) in advance of its intention to commence any action on its own behalf regarding any such claim or cause(s) of action; and/or
 - (2) immediately upon becoming aware of the fact that an action has been commenced on its behalf by some other person(s) of the tendency of such action.
- c. The Contractor will notify the defendants in any antitrust suit of the fact of the within assignment at the earliest practicable opportunity after the Contractor has initiated an action on its own behalf or becomes aware that such an action has been filed on its behalf by another person. A copy of such Notice will be sent to the Attorney General of New Jersey and the DPMC.

13.5.3 It is understood and agreed that in the event any payment under any such claim or cause of action is made to the Contractor, it shall promptly pay over to the State of New Jersey the allotted share thereof, if any, assigned to the State hereunder.

END GENERAL CONDITIONS

SECTION 011100 - SUMMARY OF WORK

PART 1 - GENERAL

1.01 RELATED DOCUMENTS

- A. Drawings and General Conditions of the Contract, including Supplemental General Conditions, apply to this Section.

1.02 PAYMENT

- A. No separate payment shall be made for performing any Work required under this Section. All costs for Work required by this Section shall be included in the applicable lump sum(s), unit price(s), or allowance(s) as set forth in Section 012901.

1.03 SUMMARY

- A. Project Information:

1. The Project is intended to provide a concrete floodwall that will provide a greater level of protection to the Municipalities (City of Hoboken, a portion of the Township of Weehawken, and a portion of the City of Jersey City), from flooding events similar to Superstorm Sandy.

The Project includes 9,900 linear feet (lf) of a concrete retaining wall, 28 roller, swing gates and stoplogs, 6 sluice gates, 2 steel flap gate, 1 steel face plate on backflow preventor manifold, H-Piles and Micropiles foundation support, steel sheet pile cutoff walls, pressure grout cutoff walls and miscellaneous drainage, curb, sidewalk and pavement removal and restoration. The 28 roller, swing gates and stop logs include an additional gate (Gate SG-3A) that is currently not shown on the plans. Gate SG-3A will be equivalent to SG-1.

2. The Project is to be constructed within municipal right of ways, private easements, and NJ Transit (NJT) and Hudson-Bergen Light Rail (HBLR) right of ways.
3. Major Work Items Included in the Work.
 - a. Approximately 9,900 lf of varying height T-wall and I-wall concrete floodwall.
 - b. 28 Floodgates and stoplog gates, 6 sluice gates, 2 steel flap gate, and 1 steel face plate backflow preventor manifold.
 - c. Approximately 59,145 lf of H-Piles.
 - d. Approximately 57,951 lf of Micropiles.

- e. Approximately 87,479 sf of steel sheet piles.
 - f. Improvements to Harborside Park (to be renamed Cove Park)
4. Phased construction.
- a. There will be restrictions in the Contractor's ability to work in multiple areas at any one time, refer to the Construction Phasing Plans included in the Construction Plan set.
5. Work under separate contracts.
- a. Sewer System Modifications - There is a separate construction contract, "Sewer System Modifications" managed by the NJ DEP that will be running concurrently with the Work of this Contract. The Contractor is to coordinate their work with the Contractor(s) performing the Sewer System Modifications work, so as to not incur any delays by either party.
 - b. Long Slip Track Extension - There is a separate construction contract managed by NJ Transit, "Long Slip" near Marin Blvd and 18th Street in Jersey City, that will be running concurrently with the Work of this Contract. The Contractor is to coordinate their work with the Contractor(s) performing the Long Slip work, so as to not incur any delays by either party.
 - c. Other NJ Transit Yard Projects – During the course of the Project, NJ Transit may issue separate construction contracts for work in and around the Terminal Yard that would run concurrently with the Work of this Contract. The Contractor is to coordinate their work with the Contractor(s) performing Other NJ Transit Yard Projects work so as to not incur any delays by either party.
 - d. Other Projects - During the course of the Project, other projects, public and private, may issue separate construction contracts for work in and around the Project area that would run concurrently with the Work of this Contract. The Contractor is to coordinate their work with the Contractor(s) performing Other Projects work, so as to not incur any delays by either party.
 - e. Cove Park Soil Remediation – There is a separate construction contract managed by the City of Hoboken that will be running concurrently with the Work of this Contract. The Contractor is to coordinate their work with the Contractor(s) performing the Cove Park Soil Remediation work, so as to not incur any delays by either party. The Contractor shall be aware that Cove Park existing site conditions as shown on the plans may change due to the Cove Park Soil Remediation project. See attached Cove Park Soil Remediation plans for reference.

6. Access to site.
 - a. Refer to the Construction Phasing Plans contained in the Construction Plans of this Work.
 - b. The Contractor shall follow all rules and requirements of New Jersey Transit, Hudson-Bergen Light Rail, and NJNY Port Authority/PATH while working in or around their property or facilities.
7. Coordination with occupants.
 - a. The Contractor will coordinate all work in public rights-of-way with the respective Municipalities or Hudson County prior to performing any work. The Contractor's work schedule will include areas of work and duration of work in those area.
 - b. The Contractor will coordinate all work in private easements with the easement property owners. The Contractor shall develop detailed work plans for all activities in those easements for review by the property owners.
 - c. The Contractor shall coordinate all work in New Jersey Transit (NJT) and Hudson Bergen Light Rail (HBLR) properties with the Construction Manager and NJT and HBLR. Contractor will be required to prepare a detailed work plan on those properties for review by NJT/HBLR. Contractor's and Subcontractor's employees, vendors, suppliers or any other persons entering the NJT/HBLR properties, will be required to attend and pass the Roadway Worker Protection training administered by the Railroad, prior to entering the property. Contractor shall allow sufficient time to attend training so as to not affect or delay work within the railroad properties.
 - d. The Contractor shall coordinate all work in Port Authority (PA) and PATH property with the Construction Manager and PA and PATH. Contractor will be required to prepare a detailed work plan on those properties for review by PA/PATH. Contractor's and Subcontractor's employees, vendors, suppliers or any other persons entering the PA/PATH properties, will be required to attend and pass the Roadway Worker Protection training administered by the PA, prior to entering the property. Anyone looking to enter the PATH tunnels for any purpose will also be required to obtain the Secure Worker Access Consortium (SWAC) credentials. Contractor shall allow sufficient time to obtain SWAC credentials and attend training so as to not affect or delay work within the railroad properties.
8. Work restrictions. (See paragraph 1.07 of this Section)
9. Specification and drawing conventions.

10. Miscellaneous provisions.

- a. Products manufactured in the United States shall be used in this work. Contractor shall follow the provisions in General Conditions Article 4.11.5.
- b. Contractor shall complete Improvements to Harborside Park (to be renamed Cove Park), within the specified contract duration. There shall be no extension to the contract duration if the Add/Alternate Bid Item No. 32 Cove Park Improvement Option B is executed.

1.04 PROJECT INFORMATION

- A. Construction Manager (CM): The Louis Berger - Hill Joint Venture.
- B. Architect/Engineer (A/E): AECOM.
- C. A/E's Consultants: The A/E has retained the following design professionals who have prepared designated portions of the Contract Documents:
 1. Magnusson Klemencic Associates.
 2. Matrix New World Engineering, Inc.
 3. OMA*AMO Architecture, P.C.
- D. Project Website: A project Website administered by the Construction Manager will be used for purposes of managing communication and documents during the construction stage.

1.05 WORK COVERED BY CONTRACT DOCUMENTS

- A. The Work of Project is defined by the Contract Documents and consists of the following key items of work:
 1. Approximately 9,900 lf of varying height T-wall and I-wall concrete floodwall, including, but not limited to:
 - a. 18 Rolling Floodgates and appurtenances.
 - b. 8 Swing Floodgates and appurtenances.
 - c. 2 Stoplog Gate barriers and appurtenances, 6 sluice gates, 1 steel flap gate, and 1 steel face plate.
 - d. Approximately 59,145 lf of H-Piles.
 - e. Approximately 57,951 lf of Micropiles.

- f. Approximately 87,479 sf of steel sheet piles.
- g. 2 Bridged crossings of the PATH tunnels.
- h. Urban Landscape Architectural Treatments.
- i. Improvements to Harborside Park (to be renamed Cove Park).
- j. Underground utility relocations.
- k. Maintenance and protection of traffic, including uniformed traffic directors.

B. Type of Contract:

- 1. Project will be constructed under a single prime contract. References of work to be performed by other contractors (i.e., “Irrigation Contractor”, “Landscape Contractor”, etc.), shall be the responsibility of the awarded Contractor and shall be included in the Contractor’s bid amount.

1.06 ACCESS TO SITE

- A. General: The Contractor may not have full use of Project site for construction operations during construction period. The Contractor's use of Project site may be limited by the conditions noted in Paragraph 1.07 Work Restrictions. The Contractor shall coordinate construction sequencing and scheduling with other ongoing projects including, but not limited to NJT Long Slip project, NJT Monopole project, Hartz Mountain ATIR project, Lincoln Equities Holland Park project, and other county or municipal projects.
- B. Limits of Work shown on the Construction Plans and within permanent and/or temporary construction easements.
 - 1. Driveways, Walkways and Entrances: Keep driveways, sidewalks, and public access areas and entrances serving premises clear and available to the public at all times, unless noted otherwise in the “Maintenance and Protection of Traffic” Plans and Specifications.

1.07 WORK RESTRICTIONS

- A. Work Restrictions, General: Comply with restrictions on construction operations.
 - 1. Comply with limitations on use of public streets and with other requirements of the Municipalities such as:
 - a. Scheduled festivals, street fairs or other community events.
 - b. Phasing of adjacent work areas that may affect linear activities.

- c. School schedules
 - d. Noise ordinances.
 - e. Nighttime work at the direction of the municipality.
2. New Jersey Transit (NJT)
- a. The Contractor is to comply with all NJT requirements for accessing and working on NJT property.
 - b. All of the Contractor's employees assigned to the Project must obtain NJT track safety training before being allowed to access any NJT property.
 - c. The Contractor is to provide a work plan for work on or adjacent to NJT property for the review and approval of NJT. The Contractor to revise his plan of work as required by NJT at no additional cost to the NJDEP.
 - d. NJT may stop the Contractor's work if NJT flagmen are not available.
 - e. NJT may restrict the Contractor's working hours if there is a conflict with rail operations. This may include nighttime work.
3. Hudson-Bergen Light Rail (HBLR)
- a. The Contractor is to comply with all HBLR requirements for accessing and working on HBLR property.
 - b. All the Contractor's employees assigned to the Project must obtain HBLR track safety training before being allowed to access any HBLR property.
 - c. The Contractor is to provide a work plan for work on or adjacent to HBLR property for the review and approval of HBLR. Contractor to revise his plan of work as required by HBLR at no additional cost to the DEP.
 - d. HBLR may stop the Contractor's work if HBLR flagmen are not available.
 - e. HBLR may restrict the Contractor's working hours if there is a conflict with rail operations. This may include nighttime work.
4. Port Authority/PATH (PA/PATH)
- a. The Contractor is to comply with all PA/PATH requirements for accessing and working on or near PA/PATH property.

- b. The Contractor is to provide a work plan for work on or adjacent to PA/PATH property for the review and approval of PA/PATH. The Contractor to revise his plan of work as required by PA/PATH at no additional cost to the DEP.
 - c. PA/PATH may restrict the Contractor's working hours if there is a conflict with rail operations. This may include nighttime work.
- B. On-Site Work Hours: Normal daytime construction activity shall take place only between the hours of 8:00 a.m. to 6:00 p.m., excluding Saturdays, Sundays, and legal holidays. Night construction activity pending approval from the Municipality shall take place between the hours of 9:00 p.m. to 5:00 a.m., excluding Saturdays, Sundays, and legal holidays. Work outside the above time periods will be permitted only with the written approval of the appropriate municipalities (County of Hudson, City of Jersey City, City of Hoboken, and Township of Weehawken). Refer to paragraph C for NJT and HBLR working hours.

Contractor shall coordinate and confirm on-site work hours with the appropriate municipality prior to commencing construction activities so as to not interfere with Contractor's overall project schedule. Contractor shall be prepared to adjust their on-site work hours accordingly to accommodate restrictions from the appropriate municipality. Contractor shall be prepared to work nighttime hours if and where directed.

Regular Working Hours, as defined under Section 011100 Summary of Work, may be further restricted by order of the Construction Manager in coordination with NJT, HBLR, PATH, AMTRAK, NJDOT, City of Hoboken, City of Weehawken, or Jersey City. In the event that work cannot be rescheduled during regular working hours and consequently required to be performed outside of stipulated working hours and require working during premium time working hours, Item 33 Nighttime Work, If and when directed, will reimburse the Contractor for the premium time incremental hourly wages paid to field staff. Daily Time Sheets shall be submitted to the Construction Manager and Certified Payroll Records will be the basis of reimbursement.

- C. New Jersey Transit (NJT) – Hudson-Bergen Light Rail (HBLR) Work Hours -
- 1. NJT – Work within NJT property may be restricted during rush hours, 6:00 A.M. to 10:00 A.M. and 3:00 P.M. to 9:00 P.M., Monday through Friday, so as not to affect NJT operations or commuter access.
 - 2. HBLR – Work within HBLR property may be restricted during rush hours, 6:00 A.M. to 10:00 A.M. and 3:00 P.M. to 9:00 P.M., Monday through Friday, so as not to affect HBLR operations or commuter access.
 - 3. The crossing of the HBLR track will be limited to Saturday 3:00 A.M. to Sunday 9:00 P.M.

4. Contractor shall coordinate and confirm on-site work hours with NJT and HBLR prior to commencing construction activities so as to not interfere with Contractor's overall project schedule. Contractor shall be prepared to adjust their on-site work hours accordingly to accommodate restrictions from NJT and HBLR. Contractor shall be prepared to work nighttime hours if and where directed.
- D. Existing Utility Interruptions: Contractor shall not interrupt any utilities unless permitted under the following conditions and then only after providing temporary utility services according to requirements indicated:
1. Notify Construction Manager and utility owner no less than two (2) weeks in advance of proposed utility interruptions.
 2. Obtain Construction Manager's and utility owner's written permission before proceeding with utility interruptions.
- E. Combustion engine emissions, Noise, and Dust: Refer to Environmental Specifications for monitoring and limiting emissions, noise, and dust during construction activities.
- F. Vibration and Settlement: Refer to the Geotechnical Specifications for monitoring and allowable limits to vibration and settlement during construction activities.

1.08 SPECIFICATION AND DRAWING CONVENTIONS

- A. Specification Content: The Specifications use certain conventions for the style of language and the intended meaning of certain terms, words, and phrases when used in particular situations. These conventions are as follows:
1. Imperative mood and streamlined language are generally used in the Specifications. The words "shall," "shall be," or "shall comply with," depending on the context, are implied where a colon (:) is used within a sentence or phrase.
 2. Specification requirements are to be performed by Contractor unless specifically stated otherwise.
- B. Division 01 General Requirements: Requirements of Sections in Division 01 apply to the Work of all Sections in the Contract Sections.

1.09 DRAWING COORDINATION

- A. Requirements for materials and products identified on Drawings are described in detail in the Contract Sections.

1.10 CONSTRUCTION SCHEDULE ADDITIONAL REQUIREMENTS

- A. The Contractor shall prepare, maintain and modify as required an accepted detailed progress schedule as described below in addition to the requirements of Article 6 of the General Conditions. This progress schedule shall be prepared in such a manner as to permit the orderly planning, organization, and execution of the work, including the recording and reporting of actual performance, progress and plans to complete all Contract work. The progress schedule shall be based on the Critical Path Method (CPM) technique (the progress schedule is referred to herein as the “CPM”).
- B. A Scheduling Kick-off meeting between the DEP, Contractor, Contractor's scheduler and the Construction Manager and Scheduler will be held after Award. At a minimum, the following items will be discussed at the Scheduling Kick-off meeting: contract schedule requirements, project phasing, intermediate milestones, calendar workdays, schedule activity coding, schedule updating, schedule revisions, and any other items related to the Project Schedule Document development.
- C. The Contractor shall prepare the CPM in accordance with industry principles, standards and best practices. These include, but are not limited to, the instructions listed below. These instructions and the term "CPM" apply to Computerized CPM Schedules and all other required scheduling data.
 - 1. Each activity in the CPM shall include each of the items listed below (a - h) and shall be presented in one integrated and computerized schedule. That is, the Contractor shall incorporate all of this information into a scheduling software system.
 - a. Activity Description: The activity description shall clearly describe the work to be performed.
 - b. Activity Duration: Time estimates for each activity shall be expressed in full business days and shall be based on the anticipated time required to do the physical work of the activity.
 - c. No individual activity shall have a duration greater than 20 business days, except in the case of non-construction activities such as procurement of materials, fabrication and delivery of equipment, or other such activities which may be approved by the Construction Manager.
 - d. Other Codes: If any other activity codes are required (area, phase, milestones, specification item number, etc.), they will be discussed and agreed upon with the Construction Manager.
 - e. Activity Manhours: Manhour estimates that are required to complete the activity shall be identified. The Construction Manager reserves the right to

accept or reject any value and allocation of manhours. The manhours shall be shown as a resource.

- f. Logic Relationships: Only Finish to Start relationships are permitted. Lag time on any relationships is not allowed. Start to Start relationships may be accepted, but they shall be identified and submitted to the Construction Manager for approval.
 - g. Calendar: The calendar(s) basis used to develop the schedule shall be provided with the initial submittal. Items to be identified include holidays and work week (number of days per week and number of hours per day). All imposed dates shall be identified and explained.
 - h. All CPM schedules shall be prepared with the latest version “Oracle Primavera P6” or a version as indicated by the Construction Manager.
- D. The CPM shall be sufficiently detailed to accurately depict all the work required by the Contract and shall demonstrate the sequence and duration of all work activities in accordance with the requirements set forth in this Contract.
- E. The critical path identified by the Contractor on the CPM shall be determined according to CPM principles. All intermediate and/or contractual milestones and imposed dates shall be identified. Float shall be calculated against all contractual milestones and any other milestone established by the Construction Manager.
- F. The CPM shall be prepared and maintained by a Project Scheduler with at least three (3) years of relevant scheduling experience in planning, scheduling, expediting and maintaining the progress of the work on construction projects of a similar nature. The name, résumé and work experience of the Contractor's Project Scheduler shall be submitted to the Construction Manager and approved before work on the Schedule document commences. Should the Contractor utilize a Scheduling Consultant, the Consultant's name and work experience shall be submitted to the Construction Manager and approved before commencing work on the Schedule Document.

If either the proposed Consultant or the Contractor's Project Scheduler is not approved, the Contractor shall propose an alternate Consultant or another Scheduler within five (5) business days. The Construction Manager's approval of the proposed personnel is required before work is initiated on the CPM.

- G. The CPM Package submitted to the Construction Manager, either as an initial schedule, a revision or as a subsequent update, shall include the following:
- 1. The following tabulated and graphical reports:
 - a. Gantt Chart: Bar chart that illustrates the project schedule, showing the dependency relationships between activities and the current schedule status.

- b. Longest Path (Critical Path) Report: This report is a listing of all activities, except those that are completed, with all predecessor and successor relationships sequenced by total float.
 - c. Manhour Report: A report that shows the planned monthly noncumulative manhours that are generated from the CPM schedule. The Manhour Report shall be updated each month to reflect the projected remaining manhours required to complete the activities. The Manhour Report shall be presented in a graphical (curves) format.
2. Narrative Report: A report that shall be signed by the Contractor's Project Manager and shall include, but not be limited to:
- a. A discussion and analysis of why the project has gained or lost time since the previous update.
 - b. A discussion of the overall progress and goals.
 - c. A justification and identification of activities that were worked out of sequence.
 - d. A description of problem areas.
 - e. Identify and discuss planned staffing versus actual staffing usage and provide projections by Subcontractor.
 - f. Current and/or anticipated delaying factors and their potential impact.
 - g. An explanation of corrective action (recovery plan) either taken or proposed for all critical areas.
 - h. A listing of all intermediate contractual milestones with their respective float and schedule analysis.
 - i. Define activities that were not started or completed as scheduled and provide explanation.
 - j. Identify outstanding "Requests for Information (RFI)" and discuss their cost and/or schedule impact.
3. Distribution: CPM Packages shall be submitted via email to the Construction Manager. All required Schedule and Narrative information, including the relevant scheduling software file (XER file format), shall be submitted as attachments as part of the schedule package.

- H. Within thirty (30) business days after the Notice to Proceed of the Contract, the Contractor shall make a presentation to the Construction Manager and DEP concurrently with the submittal for acceptance of the Preliminary CPM. The Preliminary CPM shall contain in detail the Contractor's proposed schedule of all Work to be commenced within the first year after the Notice of Award. This CPM shall include, in a summary format, the balance of Work leading to Substantial Completion of the Project. A Preliminary CPM with a longer time duration than that specified (elsewhere) will not be accepted. This Preliminary CPM shall conform in all respects to the criteria set forth in this section. The Preliminary CPM package may be conditionally accepted by the Construction Manager pending acceptance of the Detailed CPM. The conditionally accepted Preliminary CPM shall be updated monthly until the Detailed CPM is accepted. The Contractor may make no changes to the conditionally accepted Preliminary CPM without the approval of the Construction Manager and DEP.
- I. Within ten (10) business days from receipt of the Preliminary CPM, the Construction Manager will review the Preliminary CPM and return it to the Contractor either with comments or conditionally accepted. During this time, the Contractor shall participate in the review and evaluation of the Preliminary CPM with the Construction Manager. Within 10 business days after comments are received, the Contractor shall address the Construction Manager's comments and resubmit a corrected Preliminary CPM package. The Contractor shall repeat this process as many times as required at no additional cost to the State until the Construction Manager and DEP conditionally accept the Preliminary CPM.
- J. Within one hundred (100) business days after the Notice to Proceed of the Contract, the Contractor shall make a presentation to the Construction Manager and DEP concurrently with the submittal for acceptance of the Detailed CPM. The Detailed CPM shall contain the Contractor's proposed schedule for completing all the contractual Work in the time allowed (shown elsewhere). A CPM with a longer time duration than that specified (elsewhere) will not be accepted. This Detailed CPM shall conform in all respects to the criteria set forth in this section.

Within twenty (20) business days from receipt of the Detailed CPM, the Construction Manager will review the Detailed CPM and return it to the Contractor either with comments or accepted. During this time, the Contractor shall participate in the review and evaluation of the Detailed CPM by the Construction Manager. Within 10 business days after comments are received, the Contractor shall address the Construction Manager's comments and resubmit for acceptance a corrected Detailed CPM package. The Contractor shall repeat this process as many times as required until the Construction Manager and DEP accept the Detailed CPM at no additional cost to the State.

- K. Upon review and acceptance, the Contractor's submitted Detailed CPM, described in paragraph (J), will be deemed to be the "Baseline Schedule". (The use of the term "Baseline Schedule" refers to the early dates; the late dates are for the purpose of calculating float, and do not represent the schedule). This Baseline Schedule shall be used

by the Contractor for planning, scheduling and executing the Work and for monitoring and reporting progress to the Construction Manager. The Contractor may make no change to the Baseline Schedule without the approval of the Construction Manager and the DEP.

- L. The Contractor and the Contractor's Project Scheduler shall participate with the Construction Manager and the DEP in Monthly Schedule Review/Update Meetings. The purpose of these meetings shall be to obtain joint agreement on job progress shown on the Activity List (see paragraph G above) and update the CPM as well as to discuss schedule-related problem areas, proposed logic changes and resolve any questions pertaining to the schedule. These meetings shall precede the formal submittal of the monthly updated CPM Schedule. Both the date and location of the meeting will be determined by the Construction Manager.

Three (3) business days prior to the Monthly Schedule Review/Update Meeting, the Contractor shall provide to the Construction Manager two (2) sets of the "Activity List" (see paragraph G above) which will identify, at a minimum, the following information for all activities that have started, are in progress, or have been completed during the reporting period.

1. Assessment of each in-progress activity's remaining duration
2. The actual start and finish dates whenever appropriate

Subsequent to the Monthly Schedule Review/Update Meeting, and in concert with the agreements made at said meeting with regard to progress, the Contractor shall update the CPM Schedule and provide all required reports showing current progress of the work as well as a plan and schedule of the completion of the remaining work. The CPM shall be updated as of the first working day of each calendar month or any other day as determined by the Construction Manager and shall be submitted within five (5) business days of the monthly schedule review and update meeting, until actual Substantial Completion of the Project is declared.

The update shall comply with the criteria and format set forth in this section.

- M. On every progress update, the Contractor may also report physical percent complete as of the status date, for all activities in progress. The physical percent complete for each activity should be established in the following manner: For activities that are quantifiable, the physical progress equals the quantity installed or erected divided by the total quantity allocated to the particular activity (including overruns and underruns). For those activities that cannot be quantified, physical percent complete shall be estimated.
- N. In the event that the Construction Manager determines that there will be or has been a delay which might affect the critical path(s), the Construction Manager will instruct the Contractor to analyze the circumstances as to whether the critical path(s) is or will be affected thereby and submit a proposed recovery plan.

- O. In the event that it is necessary to revise the CPM's schedule, a revised CPM shall be submitted for acceptance at no additional cost to the State. Reasons for revision may include, but are not limited to, incorporation of an approved Change Order, modification of activity manhours, if the Construction Manager determines that Work is not progressing to meet the accepted CPM, when a delay is affecting the critical path(s), or if the Work is not performed as shown in the accepted CPM.

In all situations in which the CPM schedule is revised, the Contractor shall submit a narrative explaining the reasons for the changes. In addition, the Contractor shall submit a listing of all proposed changes in network logic including, but not limited to changes in activity duration and logic, changes in activity manhours and quantity (if required), changes in activity sequence and any changes in completion dates. Revisions to the CPM shall only be made after authorization by the Construction Manager and the DEP.

Upon the Construction Manager's direction, the proposed schedule changes shall be added into the CPM and shall be submitted to the Construction Manager for review and acceptance within five (5) business days. Any revisions to the CPM shall conform in all respects to the criteria set forth in this section.

- P. In those cases, in which the Contractor is submitting a schedule delay claim, the claim request shall include a schedule subnet, tabular reports and an explanation that clearly demonstrates the impact of the claim on the Project Schedule. The Schedule to be utilized as the basis for the claim shall be the "Current Updated Schedule" which reflects the status of the Project at the time the delay occurred. The Contractor shall provide to the Construction Manager, as a minimum, the following information:
1. Schedule subnets (logic diagrams) and tabular reports (prior to and after the Change Order insertion) that clearly demonstrate the schedule impact on the entire Current Updated Schedule. Whenever the Contract calls for a CPM schedule, CPM tabular reports also shall be submitted as specified in paragraph G above.
 2. Impact on the activity's manhours and quantities (if required).
 3. Schedule impact on material and/or equipment procurement, fabrication and delivery schedules.
 4. Narrative that clearly identifies, describes, and substantiates the schedule impact on both the affected and subsequent (unchanged work) activities.
 5. Corrective action that can be taken in order to avoid/minimize the schedule impact.
 6. Any other tabular/graphical reports required by the Construction Manager.
- Q. The float or slack is not time for the exclusive use or benefit of either the State or the Contractor. Extensions of time for performance under any and all of the provisions of this Contract will be granted only to the extent the equitable time adjustments for the activity

or activities affected exceed the total float along the paths involved at the time the delay occurred or notification was issued for the change. “

- R. In addition, the Contractor shall prepare and submit a two (2) week look ahead schedule and logistical plans, herein referred to as the Two Week Look Ahead, on a weekly basis to the Construction Manager. The Two Week Look Ahead shall be submitted to the Construction Manager no later than the prior Thursday for the following two (2) weeks. The Two Week Look Ahead shall include, at a minimum, the following items:
1. Date range of the Two Week Look Ahead.
 2. Locations of planned work activities for the following two (2) weeks, to include the street names and intersections impacted.
 3. Roadway closures (if required).
 4. General work description of planned activities for each day on the Two Week Look Ahead.
 5. Number of Police Officers (Hoboken, NJ Transit, etc.) required, to include time range in hours.
 6. Locations of required ‘No Parking’ signs, to include time range in hours/days.

PART 2 - PRODUCTS

(Not Used)

PART 3 - EXECUTION

(Not Used)

END OF SECTION 011100

NO TEXT ON THIS PAGE

SECTION 011414 – CONTROL OF WORK

PART 1 - GENERAL

1.01 RESTRICTIONS AND HOURS OF CONSTRUCTION

- A. Refer to Section 011100; Article 1.07 for details of working hours and other project restrictions.

1.02 PAYMENT

- A. No separate payment shall be made for performing any Work required under this Section. All costs for Work required by this Section shall be included in the applicable lump sum(s), unit price(s), or allowance(s) as set forth in Section 012901.

1.03 NOISE

- A. All work by the Contractor shall comply with all requirements of the City of Hoboken's Noise Ordinance "Chapter 133 – Noise Control" effective March 14, 2011, and the City of Jersey City's Noise Ordinance "Chapter 222 - Noise".

1.04 RELATED SECTIONS

- A. General Conditions Article 4
- B. Section 011100 – Summary of Work
- C. Section 023219 - Subsurface Utility Locating (Potholing).
- D. Section 340113 - Operation and Maintenance of Roadways.

1.05 WORK ZONE LIMITS

- A. The Contractor shall not (except after written consent from the proper parties) enter or occupy with personnel, tools, materials or equipment any private property or public rights-of-ways outside the work zone limits as shown on the Contract Drawings. The Contractor shall coordinate with the Construction Manager to obtain written consent prior to entering or occupying land with the intent to stage and/or perform construction work outside of the work zone limits.

1.06 UTILITY LOCATIONS

- A. Comply with all requirements of the One-Call Damage Prevention System. Contact New Jersey One Call at <https://www.nj1-call.org> or 1-800-272-1000 (or dial 811) no less than three (3) and no more than 10 days prior to the start of subsurface work. Verify with each

utility owner if it requires that a representative be present during excavation, and, if required, coordinate with representative. Take all precautions required by the utility owner.

- B. Underground utilities are indicated on the Contract Drawings. These locations are approximate and neither the Construction Manager, A/E nor DEP makes any assurances that they are accurate or complete. The Contractor is to perform its own investigation of the utility locations and to take all necessary precautions to avoid damaging the utilities in the course of its Work.
- C. Contractor shall be aware that this project is located in a historic, dense urban environment. While effort has been made to identify underground utilities, there is a likelihood that unidentified underground utilities may exist. Added, the structural condition of the utilities is unknown and may be in a friable or fragile state. As such, Contractor shall be solely responsible for locating, protecting, and repairing all utilities (regardless of known or unknown location or condition) that are encountered during the Work. Following utility mark outs, test pits, and potholing, the Contractor shall supplement its efforts to identify underground utilities and obstructions by utilizing ground penetrating radar (GPR) for the length of the project floodwall within the properties of New Jersey Transit and Hudson Bergen Light Rail. The Contractor shall verify markout locations, and locate additional unmarked utilities, metallic and non-metallic pipes (PVC, AC, Concrete, VC) and non-utility structures (vaults, foundation walls, etc.) within the floodwall alignment footprint, prior to executing any Work to construct the Resist Structure within the following limits, Station 10+26.75 to Station 12+18.44, Station 300+05.01 to Station 313+24.03, Station 325+78.94 to Station 352+00.00, and Station 409+53.64 to Station 411+01.47. Contractor shall submit all data, reports, and interpretive information verifying and identifying utilities in conflict with the Work under the Contract to Construction Manager within seven (7) calendar days of the exploratory work. Test pits as deemed necessary by the Construction Manager will be performed as detailed under Section 023219.

1.07 DIMENSION OF EXISTING STRUCTURES

- A. The Contractor shall verify the dimensions and locations of existing structures in the field before the fabrication of any material or equipment that is dependent on the correctness of such information.

1.08 OPEN EXCAVATIONS

- A. All open excavations shall be adequately safeguarded by providing temporary barricades, fencing, caution signs, lights, and other means to prevent accidents to persons and damage to property, and in accordance with applicable occupational health and safety regulations and local municipality requirements. The Contractor shall, at his own expense, provide suitable and safe crossings for accommodating travel by pedestrians and workmen. Bridges provided for access during construction shall be removed when no longer required. The length or size of excavation will be controlled by the particular surrounding

conditions but shall always be confined to the limits shown on the Contract Drawings. If the excavation becomes a hazard, or if it excessively restricts traffic at any point, the Construction Manager may require special construction procedures, at the Contractor's sole cost and expense, such as limiting the length of the open trench, prohibiting storing excavated material in the street, and requiring that the trench not remain open overnight.

- B. The Contractor shall take precautions to prevent injury to the public due to open trenches. All trenches, excavated material, equipment, or other obstacles that could be dangerous to the public shall be well lighted at night.

1.09 TEST PITS

- A. Test pits for the purpose of pre-characterization of soils properties and locating underground utilities or structures in advance of the construction shall be excavated and backfilled by the Contractor at the direction of the Construction Manager. Test pits shall be backfilled immediately after their purpose has been satisfied and the surface restored and maintained in a manner satisfactory to the Construction Manager.
- B. Procedures for test pits (potholing) are found in Section 023219.

1.10 INTERFERENCE WITH AND PROTECTION OF STREETS

- A. The Contractor shall not close or obstruct any portion of a street, road, or private way without obtaining permits from the proper parties. If any street, road, or private way shall be rendered unsafe by the Contractor's operations, they shall make such repairs or provide such temporary ways or guards as acceptable to the proper parties. "Operation and Maintenance of Roadways" are described in Section 340113.
- B. Streets, roads, private ways, and walks not closed shall be maintained passable and safe by the Contractor, who shall assume and have full responsibility for the adequacy and safety of provisions made therefor.
- C. Contractor shall provide pedestrian passageways through or around all work zones as shown on the Contract Drawings.
- D. The Contractor shall, at least two (2) weeks in advance, notify the Municipalities and/or County in writing, with a copy to the Construction Manager if the closure of a street or road is necessary. The Contractor shall cooperate with the Municipalities and/or County in the establishment of alternate routes and shall provide adequate detour signs, plainly marked and well lighted, in order to minimize confusion.

1.11 TRAFFIC CONTROL

- A. Whenever work zones obstruct regular pedestrian or vehicular traffic, the Municipalities within the Project Area require uniformed officers to direct traffic. The Contractor shall coordinate with the Municipalities, based on jurisdiction of the streets and rights-of-ways, as to the number of officers required at each work zone, which shall be at the sole

discretion of the Municipalities. The Contractor will not be permitted to use his own flagmen or other workers in lieu of uniformed officers.

- B. NJT may also require additional NJT officers to direct NJT employee vehicles, emergency vehicles and/or buses around affected work zones. The Contractor shall coordinate with NJT as to the required number and location of NJT officers, which will be at the sole discretion of NJT.
- C. DEP shall reimburse the Contractor the cost of such uniformed officers. Such cost shall consist of the actual wages paid to such officers. The Contractor will be responsible for coordinating with the Municipalities to set up payment terms and accounts as required. The Contractor will be required to submit sufficient backup to DEP, including invoices from the Municipalities, plus daily officer sign-in logs, including names, start and end times, and work zone locations of the officers working each day.
- D. The presence of uniformed officers shall in no way relieve the Contractor of any responsibility or liability which is his under the terms of the Contract.

1.12 CARE AND PROTECTION OF PROPERTY

- A. In addition to paragraph B, the Contractor shall also follow the provisions in General Conditions Article 4.15.2.a.(3).
- B. The Contractor shall be responsible for the preservation of all public and private property, and shall use every precaution necessary to prevent damage thereto. If any direct or indirect damage is done to public or private property by or on account of any act, omission, neglect, or misconduct in the execution of the Work on the part of the Contractor, such property shall be restored by the Contractor, at their expense, to a condition similar or equal to that existing before the damage was done, or they shall make good the damage in other manner acceptable to the Construction Manager.
- C. Damage to NJ Transit or HBLR property. All damages to NJ Transit/HBLR property caused by the Contractor's operations or its Subcontractors, shall be repaired by the Contractor or at the Contractor's expense by NJ Transit, at the discretion of NJ Transit. Any damage that interferes with railroad operations, Project work shall not continue until the damage is repaired to the satisfaction of NJ Transit and the railroad is back in service.

1.13 PROTECTION AND RELOCATION OF EXISTING STRUCTURES AND UTILITIES

- A. The Contractor shall assume full responsibility for the protection of all buildings, structures, and utilities, public or private, including poles, signs, services to buildings, utilities in the street, gas pipes, water pipes, hydrants, sewers, drains, and electric and communication conduits and cables, whether or not they are shown on the Drawings. The Contractor shall carefully support and protect all such structures and utilities from injury of any kind. Any damage resulting from the Contractor's operations shall be repaired by them at their sole cost and expense.

- B. The Contractor bears full responsibility for obtaining all locations of underground structures and utilities. Services to buildings shall be maintained, and all costs or charges resulting from damage thereto shall be paid by the Contractor. As approved by the Construction Manager, locate utilities by potholing in accordance with Section 023219.
- C. Protection and temporary removal and replacement of existing utilities and structures as described in this Section shall be a part of the Work under the Contract and all costs in connection therewith shall be included in the Total Price Bid in the Bid Form.
- D. In addition to those utility relocations called out and shown on the Drawings, if additional permanent relocation of a utility is required, as determined by the Architect/Engineer or Utility Owner, the Construction Manager may direct the Contractor, in writing, to perform the Work. Work so ordered will be paid under the allowance item in the Bid, or as extra work under Article 11 of the Supplementary Conditions. The Contractor shall fully cooperate with the Municipality and utility owner and shall have no claim for delay due to such relocation.
- E. Comply with all requirements of the One-Call Damage Prevention System. Contact New Jersey One Call at <https://www.nj1-call.org> or 1-800-272-1000 (or dial 811) no less than three (3) and no more than ten (10) days prior to the start of subsurface work. Verify with each utility owner if it requires that a representative be present during excavation, and, if required, coordinate with representative. Take all precautions required by the utility owner.
- F. The Contractor shall coordinate the removal and replacement of traffic loops and signals, if required for the performance of the work, at no additional cost to the DEP.

1.14 COOPERATION WITHIN THIS CONTRACT

- A. All firms or persons authorized to perform any work under this Contract shall cooperate with any and all other contractors involved with the Project and shall assist in incorporating the work of other trades where necessary or required.
- B. Cutting and patching, drilling, and fitting shall be carried out where required by the trade or subcontractor having jurisdiction, unless otherwise indicated herein or recommended by the Construction Manager.

1.15 CLEANUP AND DISPOSAL OF EXCESS MATERIAL

- A. During the course of the work, the Contractor shall keep the site of his operations in as clean and as neat a condition as is possible. They shall dispose of all residues resulting from the construction work and, at the conclusion of the work, they shall remove and dispose any surplus excavation, broken pavement, lumber, equipment, temporary structures, and any other refuse remaining from the construction operations, and shall leave the entire site of the work in a neat and orderly condition.

- B. In order to prevent environmental pollution arising from the construction activities related to the performance of this Contract, the Contractor and his subcontractors shall comply with all applicable Federal, State, and local laws, and regulations concerning waste material disposal, as well as the specific requirements stated in this Section and elsewhere in the Contract Sections.

- C. The Contractor is advised that the disposal of excess excavated material in wetlands, stream corridors, and plains is strictly prohibited, even if the permission of the property owner is obtained. Any violation of this restriction by the Contractor or any person employed by them will be brought to the immediate attention of the responsible regulatory agencies, with a request that appropriate action be taken against the offending parties. Therefore, the Contractor will be required to remove the fill and restore the area impacted at their own expense.

PART 2 - PRODUCTS

(Not Used)

PART 3 - EXECUTION

(Not Used)

END OF SECTION 011414

SECTION 011433 - WORK IN RIGHTS-OF-WAY

PART 1 - GENERAL

1.01 DEFINITIONS

- A. As used in this numbered Section, and this Section only, the terms used herein shall have the following meaning:
1. The terms "Traffic Lane", "Lane", "Active Roadway", "Street" and "Roadway" shall mean, in addition to the normally traveled pavement areas, other areas including, but not limited to, ramp terminal gore areas, roadway shoulders, and all other areas that may foreseeably be occupied by moving vehicles.
 2. "Flashing Arrow Sign Unit" (FASU) shall mean an engine/generator-, solar- or battery-powered flashing light sign with lights displayed in the shape of an arrow.
 3. "Slow-Moving Vehicles" shall mean vehicles or equipment that travel at or under a speed corresponding to 15 mph less than the posted speed limit.
 4. "Work Area" shall mean the area immediately surrounding the Work in progress, typically, where workers are afoot, and/or the space within a Roadway where Work on the Roadway is being performed by the Contractor.
- B. General Requirements
1. Conform to requirements of this numbered Section, the Contract Drawings, and the following:
 - a. Portions of the latest editions, including all amendments thereto, of the Federal Highway Administration (FHWA): "Manual on Uniform Traffic Control Devices" (MUTCD) Part VI as hereinafter specified and applicable portions of the companion "Traffic Control Devices Handbook" (TCDH); "Standard Highway Signs"; and "Standard Specifications for Construction of Roads and Bridges on Federal Highway Projects".
 - b. The latest edition of the American Association of State Highway and Transportation Officials (AASHTO): "Roadside Design Guide", Chapter 9: "Traffic Barriers, Traffic Control Devices, and Other Safety Features for Work Zones"; and "Standard Specifications for Highway Bridges," as hereinafter specified.
 - c. The requirements of the Americans with Disabilities Act (ADA) laws in all respects as specified in the "2010 Standards for Accessible Design."

- d. FHWA's "Portable Changeable Message Signs Handbook" (PCMS).
- e. Maintenance of traffic and Work Area protection features specified herein and as shown on Contract Drawings and/or sketches to be furnished to the Contractor.
- f. In the event of a technical conflict between a requirement in the publications referenced herein and the Contract Sections and Contract Drawings, the requirements of the Contract Sections and Contract Drawings shall control.
- g. There may be more than one Work Area within the confines of a closed Roadway or Traffic Lane. Each Work Area shall be individually protected as specified herein.
- h. There may be other ongoing construction contracts within the vicinity of the Work Area. The Contractor shall not move, modify or relocate any item associated with these other contracts without prior approval of and coordination with the Construction Manager.
- i. Perform Work in such a manner and sequence as to interfere as little as possible with the passage of vehicles, pedestrians and other kinds of public traffic.
- j. All existing roadway items such as guiderail, pavement markings, curbs, signals and signs damaged by the Contractor shall be restored by them to the satisfaction of the Construction Manager at no additional cost to New Jersey Department of Environmental Protection (NJDEP).
- k. Street lighting, traffic signals and other utilities that are in close proximity to the proposed work shall be protected in place. Where removal of the utility is required to complete the work, Contractor shall remove, store, and re-install the utility at no additional cost to the DEP. Contractor shall bear the sole responsibility for coordinating with the utility owner, installing temporary traffic signals and lighting as required by the utility owner, and all costs associated with performing the work.

C. Contractor-Furnished Materials and Equipment

- 1. Comply with the requirements specified in Section 016100
- 2. Provide and maintain in good working order all materials, equipment, temporary construction signs and facilities required for proper maintenance of traffic and Work Area protection, as specified herein and/or shown on the Contract Drawings. All said equipment/devices shall remain the property of the Contractor, unless otherwise shown on the Contract Drawings.

3. All traffic control devices shall be properly installed prior to the commencement of the work to which they apply and shall be properly maintained by the Contractor thereafter. The devices shall remain in place as long as the conditions or restrictions to which they apply exist. Traffic control devices not applicable to existing conditions and restrictions shall be removed or covered over. Where roadway operations are implemented in stages, only those devices that apply to existing conditions and restrictions shall be in place.
4. All items provided under Paragraph 1.01.C.1 shall be new or undamaged previously used materials in serviceable condition conforming to requirements specified herein.
5. Provide and maintain in serviceable condition the following, where shown on the Contract Drawings or as directed by the Construction Manager:
 - a. Portable Changeable Message Signs
 - (1) Trailer Mounted Flashing Arrow Sign Unit (FASU).
 - b. Channelizing Devices
 - (1) Cones.
 - (2) Drums.
 - (3) Type III Barricades.
 - c. Vehicle-strong Barriers
 - (1) Water-filled Barrier: Conform to Contract Section 347113 and Test Level 3 as per National Cooperative Highway Research Program (NCHRP).
 - d. Temporary Signs: Conform to requirements of Contract Section 344116 (Type 1, unless otherwise shown on the Contract Drawings) hereof.
 - e. Temporary Sign Supports: All temporary maintenance of traffic and Work Area protection sign supports and mountings shall be constructed to hold the signs in their proper position and to resist swaying in the wind.
 - (1) Wooden Sign Supports: Wood conforming to requirements of Contract Section 344116.
 - (2) Portable Sign Supports: “Windmaster” as manufactured by Marketing Displays, Inc., Farmington Hills, MI.; Distinctive Displays Inc., Brooklyn, NY.; PFI Displays, Rittman, OH.; or approved equal.

- f. Back-Up Trucks: Nominal actual weight of 15,000 lbs. with nominal 24,000 lbs. gross vehicle weight registration and rear-most wheels situated close to rear of truck body. Standard "ICC" type rear bumpers are not an acceptable substitute for the required rear wheel location. Actual vehicle weight may vary depending on recommendations of the manufacturer of the vehicle-mounted impact attenuator selected. In addition, equip trucks with:
 - (1) Standard 4-lamp flashing hazard signal lights (parking and taillights).
 - (2) Four-lamp sealed beam rotating yellow warning light providing 35,000 candle power per lamp with an apparent flash rate of 120 flashes per minute. Truck mount such lights 7 to 10 feet above the Roadway and locate to be visually unobstructed by any part of truck body, load or equipment.
 - (3) Vehicle- Mounted Impact Attenuator: "TMA" units as manufactured by Energy Absorption Systems, Inc., Chicago, IL; Transpo Industries, Inc., New Rochelle, NY; Worksafe Traffic Control Industries, Inc., Berlin, VT; or approved equal.
 - g. Temporary Roadway Plates: Steel plates, sized to cover Roadway excavations with thickness and edge support adequate to accommodate HS-20-44 loading per Section 3.7.6 in the AASHTO "Standard Specifications for Highway Bridges".
6. Submit the following to the Construction Manager in accordance with General Conditions 4.7:
- a. Catalog Cuts and Data Sheets: Complete manufacturer's data for all equipment and materials.

D. General Work Area Protection

1. Contractor shall designate a supervisory-level employee with requisite onsite experience to act as the Traffic Control Coordinator (TCC). The TCC shall supervise the Traffic Management crew who shall be properly trained, supplied, staffed and equipped to deploy and remove the maintenance of traffic and Work Area protection elements required for each of the Contractor's construction activities, as shown on the Contract Drawings and in paragraph D.3 herein.
2. Traffic Maintenance crew training shall be specifically developed from this Section. The contents of Contractor's Training programs shall specifically include the Contract Drawings, Traffic Standard Details and all other requirements included on the Contract Drawings.
3. Prior to commencement of each day's Work, furnish and install where shown on the Contract Drawings, the traffic control delineations, guiding devices, signals,

signs and pedestrian protection, roadway plates, barricades and barriers. Periodically inspect, maintain, relocate, replace, cover, remove or reconstruct the devices. Maintain safe control of traffic flow and demarcate areas of Work at all times.

- a. Ensure that construction material and equipment not removed from areas of Work during non-working periods are protected in such a manner that they shall not constitute a traffic hazard.
 - b. Do not park any vehicles other than construction vehicles required for construction operations within the demarcated protected areas of Work.
 - c. Promptly remove traffic control delineations, guiding devices, signals, signs, pedestrian protection, roadway plates, barricades and barriers, where shown on the Contract Drawings, whenever operations under this Contract no longer require said Work Area protection.
 - d. Where shown on the Contract Drawings, existing permanent and temporary pavement markings and traffic guides that conflict with markings and traffic guides to be installed shall be concurrently removed prior to placement of new pavement markings and traffic guides as follows:
 - (1) On wearing surfaces that will be subsequently replaced, resurfaced or abandoned during the Work of this Contract, remove obsolete temporary marking tape and remove or obliterate obsolete thermoplastic or paint markings by grinding, scraping or other means as approved by the Construction Managers or as to completely obscure all obsolete markings for the duration of the Work.
 - (2) On finished wearing surfaces, completely remove temporary marking tape and completely remove obsolete permanent markings by grinding, scraping or other means as approved by the Construction Manager. Use of blackout paint or other coating material on any finished wearing surface is prohibited.
 - (3) Grind or chip off all adhesive residue resulting from removed or relocated traffic guides.
 - e. Prior to the end of each work period and not less than twice a day on non-workdays, the TCC shall visually inspect and maintain all elements of the maintenance of traffic and Work Area protection installations.
4. Throughout Progress of Work of This Numbered Section
- a. Maintain visual and physical accessibility to fire hydrants. Provide 24-hour notice to the Construction Manager in the event of hydrant obstruction.

7. Where excavations within pedestrian walkways including Traffic Lane crosswalks will be open to walkway pedestrian traffic prior to completion of construction, provide appropriate pedestrian railings and steel plate, wood plank or plywood covers surfaced with an approved heavy-duty, non-skid paint coating containing a grit additive. Temporary walkway covers over excavations shall be a minimum of 4-feet wide, designed and constructed to carry a minimum of 150 psf. Railings shall be approximately 3 feet 6 inches above the walkway cover and consist of a 2-inch by 4-inch wood top rail, 1-inch by 4-inch intermediate rail and a toe board 5-1/2 inches high all securely fastened to 2-inch by 4-inch wood posts spaced not more than 8 feet apart. Securely fasten wood walkway covers and posts to wood sleepers spanning excavation trench. Chamfer or asphalt ramp exposed edges and secure against displacement. Where applicable, Contractor's installations shall meet the requirements of the ADA laws in all respects.
8. Use Vehicle-strong Barriers where the Work Area contains open excavations or when materials and/or equipment are to remain in the Work Area without the presence of workers, unless otherwise shown on the Contract Drawings. Flare exposed ends of the barriers away from the Active Roadway by extending and terminating the barriers beyond the clear zone, in accordance with AASHTO's "Roadside Design Guide". Where flaring of the barriers beyond the clear zone cannot be achieved, protect the barrier end with Portable Impact Attenuators. Tapered barrier end section shall not be used unless approved by the Construction Manager.
9. Each Work Area not protected by Vehicle-strong Barriers shall be protected by a back-up truck when workers are present, unless otherwise shown on the Contract Drawings.
10. Vehicles used by the Contractor during performance of Work shall be considered as equipment vehicles and when not protected by a Vehicle-strong Barrier, said vehicle shall be protected by a back-up truck, unless otherwise shown on the Contract Drawings.
11. Construction material and equipment shall not be stored outside the Work Area, without approval by the Construction Manager.
12. Slow-Moving Vehicles traveling on a Roadway outside of demarcated protected Work Areas shall be followed (approximately 50 feet behind) by a vehicle displaying the same flashing hazard signal lights and sealed beam rotating yellow warning light as required for back-up trucks.
13. Traffic lanes and other areas closed by the Contractor shall be cleared of all materials, equipment and debris to the satisfaction of the Construction Manager, prior to reopening the lanes to traffic.

E. Spare Materials and Equipment

1. Where shown on the Contract Drawings, initially furnish and subsequently maintain the quantities of spare materials and equipment at the construction site, or at another nearby location approved by the Engineer.
2. Totally revamp FASU after each single bulb failure.

F. Notwithstanding provisions herein requiring or permitting the Authority to approve or disapprove of any traffic control or delineation and guiding device provided by the Contractor, the Contractor shall ensure the suitability and performance of all such traffic control devices such that inconvenience to the traveling public is held to an absolute minimum.

1.02 PAYMENT

A. No separate payment shall be made for performing any Work required under this Section. All costs for Work required by this Section shall be included in the applicable lump sum(s), unit price(s), or allowance(s) as set forth in Section 012901.

1.03 RELATED SECTIONS

- A. General Conditions 4.7 – Shop Drawings and Other Submittals
- B. Section 016100 – Control of Materials
- C. Section 344116 - Traffic Control Equipment
- D. Section 347113 - Vehicle Traffic Barriers

PART 2 PRODUCTS

(Not Used)

PART 3 EXECUTION

(Not Used)

END OF SECTION 011433

SECTION 012901 – MEASUREMENT AND PAYMENT

PART 1 - GENERAL

1.01 DESCRIPTION

A. Summary:

1. Section includes administrative and procedural requirements for Bid Items.
2. Related Requirements:
 - a. Section 014300 "Quality Requirements" for general testing and inspection requirements.
 - b. Section 015000 "Temporary Facilities"

1.02 DEFINITIONS

- A. Unit price is an amount incorporated in the Agreement, applicable during the duration of the Work as a price per unit of measurement for materials, equipment, or services. Payment will be made for actual quantities installed.
- B. Lump Sum price is an amount incorporated in the Agreement, applicable during the duration of the Work as total compensation for materials, equipment, or services, used to complete this item of work. Contractor is to prepare a detailed Schedule of Values, acceptable to the Construction Manager, breaking down and listing the costs that are included in the lump sum total. This Schedule of Values will be used by the Construction Manager to review partial payments during the Contract period.
- C. Allowance is an amount incorporated in the Agreement, applicable during the duration of the Work, estimated by the Owner that is a cost for services from third parties or for work that cannot be quantified at the time of Bid but is required to complete the work. Contractor shall refer to General Conditions Article 9.6 Allowances. The Contractor shall not modify any Allowance in the Bid. The Allowance is to cover a cost incurred by the Contractor and paid as detailed in this Section. Changes to Allowances shall be added to or deducted from the Contract Sum by appropriate modification as detailed in Articles 10 and 11 of the General Conditions.
- D. Bid Item 32: Cove Park Improvement Option A (Base Park) includes all references throughout the Contract Documents to "Cove Park Option A", "Cove Park Opt A", "Cove Park Opt A – Base Park" or "Base Park". Add/Alt Bid Item 1: Cove Park Improvement Option B (Full Park) includes all references throughout the Contract Documents to "Cove Park Option B", "Cove Park Opt B", "Cove Park Opt B – Full Park", "Full Park" or "Complete Park".

1.03 MEASUREMENT AND PAYMENT - GENERAL

- A. The following subsections describe the measurement of and payment for the work to be done under the items listed in the BID.
- B. The Contractor shall accept in compensation, as herein provided, in full payment for furnishing all materials, labor, tools, equipment, and incidentals necessary to complete the work and for performing all work required by the Contract; also for all losses or damages caused by the actions or inactions of the Contractor, its subcontractors, material suppliers, and any other agents of the contractor, during the execution of the work and until its final acceptance by the owner, and for all risks of every description connected with the execution of the work, except as provided herein.
- C. In order to facilitate the availability of the flood gates and appurtenant equipment as needed for the work, the DEP may authorize partial payments for the flood gates and appurtenant equipment, prior to their incorporation into the work, but only in strict accordance with and subject to all the terms and conditions set forth in the following subsections numbered 1 through 13 inclusive, unless another method of payment is elsewhere provided in the specifications for specified flood gates and appurtenant equipment.
 - 1. The Contractor shall submit to DEP a written request for payments for gate procurement “phases” which would include (a) Approved Shop Drawings, (b) Production, (c) Shop Testing (d) Transportation and Delivery, (e) Installation and (f) Testing and Commissioning, (see schedule in paragraph 13), for which they desire to be paid in phases. The request shall be accompanied by a schedule of the types and quantities of each type of gate, and state where such gates and appurtenant equipment are to be stored on or off the site prior to installation.
 - 2. Where the gates and appurtenant equipment are to be stored off the site, they shall be stored at a place other than the Contractor’s premises (except with the written consent of the DEP) and under the conditions prescribed or approved by the DEP. The Contractor shall set apart and separately store at the place or places of storage all gates and appurtenant equipment and shall clearly mark same “Property of the State of New Jersey”, and further shall not at any time move any of said gates and appurtenant equipment to another off-site place of storage without the prior written consent of the DEP. Materials may be removed from their place of storage off the site for incorporation in the work upon approval of the Construction Manager.
 - 3. Where gates and appurtenant equipment are to be stored at the site, they shall be stored at such locations as shall be approved by the Construction Manager and only in such quantities as, in the opinion of the Construction Manager, will not interfere with the proper performance of the work by the Contractor or other contractors then engaged in performing work on the site. Such gates and appurtenant equipment

shall not be removed from their place of storage on the site except for incorporation in the work, without the approval of the Construction Manager.

4. All costs, charges and expenses arising out of the storage of such gates and appurtenant equipment shall be borne by the Contractor. DEP hereby reserves the right to retain out of any partial or final payment made under the Contract an amount sufficient to cover such storage and handling costs, charges and expenses. There shall be no increase in the Contract price for such costs, charges and expenses and the Contractor shall not make any claim or demand for additional compensation, therefore.
5. The Contractor shall pay all costs of handling and delivery of gates and appurtenant equipment to the place of storage and from the place of storage to the site of the Work. The State shall have the right to retain from any partial or final payment an amount sufficient to cover the cost of such handling and delivery.
6. In the event that the whole or part of these gates and appurtenant equipment are lost, damaged or destroyed in advance of their satisfactory incorporation in the Work, the Contractor, at its own cost shall promptly replace such lost, damaged or destroyed gates and appurtenant equipment with gates and appurtenant equipment of the same character and quality. The Contractor shall also promptly replace at its sole expense work accepted under its Contract pursuant to Article 7 of the General Conditions which is lost or damaged by its negligence or carelessness or the negligence or carelessness of its subcontractors, agents or employees or by failure to comply with the provisions of this Contract. Until such time as the gates and appurtenant equipment are replaced, the State will deduct from the value of the stored materials, or from any other money due under the Contract, the amount paid to the Contractor for such lost, damaged or destroyed gates and appurtenant equipment.
7. Should any of the gates and appurtenant equipment paid for by DEP hereunder be subsequently rejected or incorporated in the Work in a manner or by a method not in accordance with the Contract and Specifications, the Contractor shall remove and replace such defective or improperly incorporated gates and appurtenant equipment with gates and appurtenant equipment complying with the Contract and Specifications. Until such time as the gates and appurtenant equipment are replaced, installed, and satisfactorily tested and commissioned, DEP shall deduct from the value of the stored gates and appurtenant equipment or from any other money due to the Contractor, the amount paid by the DEP for such rejected or improperly incorporated gates and appurtenant equipment.
8. Payment for the cost of gates and appurtenant equipment made hereunder shall not be deemed to be an acceptance of such gates and appurtenant equipment as being in accordance with the Contract Documents, and the Contractor always retains and must comply with its duty to deliver to the site and properly incorporate in the work only gates and appurtenant equipment which comply with the Contract Documents.

9. The Contractor shall retain all risks in connection with the damage, destruction or loss of the gates and appurtenant equipment paid for hereunder to the time of delivery of the same to the site of the Work and their proper incorporation in the Work in accordance with the Contract Documents.
10. The Contractor shall comply with all laws and the regulations of any governmental body or agency pertaining to the priority purchase, allocation and use of gates and appurtenant equipment.
11. When requesting payment for gates and appurtenant equipment, the Contractor shall submit with the partial estimate duly authenticated documents of title, such as bills of sale, invoices or warehouse receipts. The executed bills of sale shall transfer title to the gates and appurtenant equipment from the Contractor to the State (in the event that the invoices state that the gates and appurtenant equipment has been purchased by a subcontractor, bills of sale will also be required transferring title to the gates and appurtenant equipment from the subcontractor to the Contractor).
12. The Contractor shall include in such succeeding partial estimate requisitions a summary of gates and appurtenant equipment stored which shall set forth the quantity and value of gates and appurtenant equipment in storage, on or off the site, at the end of each proceeding estimate period; the amount removed for incorporation into the Work; the quantity and value of gates and appurtenant equipment delivered or gates in manufacturing “phases”; and the quantity and value of gates and appurtenant equipment delivered or “phases” completed for which payment thereof will be included in the current payment estimate.
13. The Contractor shall provide and perform the inspections and testing for the various types of Gate structures required by the Contract and not specifically covered by other items. The inspection and testing performed for each gate with corresponding submitted report for the specific gate. All inspections and testing required for each gate shall be included in the lump sum price paid on a gate-by-gate basis.
14. Upon proof to the satisfaction of the DEP and upon verification by the Architect/Engineer or Construction Manager that the steps a. through e. below have been completed to the satisfaction of the Architect/Engineer or Construction Manager as required under paragraph “11” or “12”, hereof, payment will be made in accordance with the following schedule:
 - a. Working (Shop) Drawings returned Furnish as Submitted 15%
 - b. Completed production of gates and appurtenances 25%
 - c. Submittal of successful Shop Tests on completed gates 10%
 - d. Transportation to Storage Area / Delivery to Site 10%

- | | | |
|----|--|-----|
| e. | Completed Installation of all components | 25% |
| f. | Testing and Commissioning | 15% |

All payments shall be subject to the prescribed retainages detailed in Article 9.7 of these Contract Documents.

- D. The payment of any partial estimate or of any retained percentage except by and under the approved final invoice, in no way shall diminish the obligation of the Contractor to repair or renew any defective parts of the construction or to be responsible for all damage due to such defects.
- E. The quantities listed in the bid documents do not govern final payment. Payments to the Contractor will be made for the actual quantities installed (and accepted) of contract items constructed in accordance with the Plans and Specifications. If, upon completion of the construction, these actual quantities show either an increase or decrease from the quantities given in the bid documents (except allowances or "if and where" items), the contract unit prices will prevail. If the quantity built exceeds the quantity indicated in the bid documents by more than 125%, NJDEP reserves the right to renegotiate the unit price and require the Contractor to provide justification for their unit prices. If the State and the Contractor cannot agree on a new unit price, then the State shall order the Contractor to provide the additional quantities of the item on a time and materials basis for the actual and reasonable costs as determined under Article 10 of the General Conditions.
- F. The payment of progress payments by the State shall not be construed as an absolute acceptance of the Work done up to the time of such payments. "Acceptance" shall mean only written acceptance signed by the DEP. Acceptance by the DEP will be made promptly after the contract has been fully completed, final inspection made, and the final certificate of the Engineer issued.
- G. The prices for those items which involve excavation shall include all costs for excavation, including but not necessarily limited to, excavation, dewatering, disposal of water generated from dewatering operations, all permits required for dewatering, and installation of all temporary sheeting and bracing, unless specifically noted otherwise. Disposal for excavated material shall be paid under a separate line item. Payment for additional excavation shall be at the sole discretion of the Construction Manager, if and where directed.
- H. In all items involving excavation, the price shall be based on doing the entire excavation in earth. Where rock or concrete structures are to be excavated, the price therefore, shall be in addition to the cost of excavating earth, and no deduction will be made in the amount for earth excavation. Payment for additional rock or concrete structure excavation will be at the sole discretion of the Construction Manager, if and where directed, and will only be utilized when the rock, as defined in the Rock / Concrete Excavation Item description, encountered during excavation has impeded the Contractor's typical production rates.

- I. The Bid may request bids on one or more Line Items to be incorporated into the Project "if and where directed" by the Construction Manager. Such items or quantities may not be located and/or depicted on the Plans. The estimated quantities set out in the Bid for such items are presented solely for the purpose of obtaining a representative bid price, but are not intended to indicate the State's anticipation as to the quantities of such items which are to be actually incorporated into the Project.

Incorporation of such items shall only be made on written directions of the State. In the absence of written directions, no such items shall be incorporated into the Project and if incorporated will not be paid for. The State may order incorporation of such items at any location within the Project, and at any time during the Contract Time.

- J. Underrun of unit price item – if during the progress of the work the actual quantity of any unit price item (except allowances or “if and where” items) required to complete the work will fall below seventy five (75) percent of the estimate quantity for that item set forth in the bid schedule, the Contractor may file a change order request to revise the unit price for that item as outlined in Article 10 and Article 11 of the General Conditions, to provide equitable compensation due to the reduced quantity.
- K. Overrun of unit price item - if during the progress of the work the actual quantity of any unit price item (except allowances or “if and where” items) required to complete the work exceeds one hundred and twenty-five (125) percent of the estimate quantity for that item set forth in the bid schedule, the State reserves the right to negotiate a new unit price for such item. If the State and the Contractor cannot agree on a new unit price, then the State shall order the Contractor to provide the additional quantities of the item on a time and materials basis for the actual and reasonable costs as determined under Article 10 and paragraph 1.05 of this Section of the General Conditions.
- L. Contractor shall be responsible for performing all the required special inspections for quality requirements to ensure specific Quality-Assurance and Quality-Control throughout the course of the contract. No separate payment shall be made for any of these inspections, application fees, or any associated fees necessary for the proper execution and completion of the Work, and which are required by the EOR and included in the Contract Documents at the time of the bid.
- M. The bid form may request bids on one or more pay items to be incorporated into the Project "if and where directed" or “if and where required" by the Construction Manager. Such items or quantities may not be located on the Plans. The estimated quantities set out in the bid form for such items are presented solely for the purpose of obtaining a representative bid price but are not intended to indicate the State's anticipation as to the quantities of such items which are to be actually incorporated into the Project. Depending on field conditions, such "if and where directed" or “if and where required” items may or may not be incorporated into the Project and if incorporated may be many times the estimated quantity or only a fraction thereof. The terms "if and where directed” and “if and where required" are used interchangeably.

Incorporation of such items shall only be made on written directions of the Construction Manager and NJDEP. In the absence of written directions, no such items shall be incorporated into the Project and if incorporated will not be paid for. The NJDEP may order incorporation of such items at any location within the Project, and at any time during the Contract Time. Claims for additional compensation shall not be made because of any increase, decrease or elimination of such items, nor because of an increase or decrease in the amount of work due to the field conditions encountered in incorporating such items into the Project.

1.04 SCHEDULE OF VALUES

- A. The Contractor is to prepare a detailed Schedule of Values for each Lump Sum item. The Schedule of Values shall be prepared as required in Article 9.3 of the General Conditions and reviewed and approved by the DEP. Coordinate preparation of the Schedule of Values for all Lump Sum items with preparation of Contractor's construction schedule. Coordinate line items in the schedule of values with other required administrative forms and schedules, including the following:
 - 1. Application for Payment forms with continuation sheets.
 - 2. Submittal schedule in accordance with Articles 4 and 6 of the General Conditions
 - 3. Items required to be indicated as separate activities in Contractor's construction schedule.
- B. Submit the Lump Sum Schedule of Values to Construction Manager for review no later than fourteen (14) days after the Notice to Proceed.

1.05 TIME AND MATERIALS CHANGE ORDER PROCEDURES

- A. The Contractor shall prepare a detailed Schedule of Labor Rates that shall be submitted with sixty (60) days after NTP.
 - 1. The Schedule of Labor Rates shall include all labor rates for personnel categories required to perform the Work. Rates provided based on union trade agreements, project labor agreements, or Prevailing Wage Rates for the work performed. Labor rates will be audited against certified payroll information presented monthly with payment requests. The labor rates provided shall be utilized as a basis for payment for any Time and Materials work that is deemed necessary and approved by the Construction Manager.
- B. For all change order work performed on a Time and Materials basis, the Contractor shall submit daily progress reports to the Construction Manager for approval. No work shall be considered eligible for payment without Construction Manager approval of daily progress report. Progress reports shall, at a minimum, include the following items.

1. Conditions of work area prior to Work, conditions of area surrounding and adjacent to the Work prior to beginning the Work, and a description of Work performed.
 2. Time and Materials tickets of all labor, equipment, tools, materials and incidentals required to perform the Work.
- C. To be considered eligible for payment, Contractor shall submit to the Construction Manager all material and equipment invoices that were utilized to perform the Work and not included in the Schedule of Equipment described above. Invoices shall be utilized as backup to justify basis of payment for all Time and Materials work.

1.06 LIMITS OF NORMAL EXCAVATION

- A. In determining the quantities of excavation to which lump sum or unit prices shall apply, the limits of normal width and depth of excavation shall be as described below, unless other limits are indicated on the Contract Drawings or specified.
- B. For pipes in trench, the normal width of the trench shall be measured between vertical planes which are a distance apart equal to the sum of 24 inches plus the outside diameter of the barrel of the pipe. If the width so computed is less than 3 feet, a width of 3 feet shall be taken as the normal width for payment. The normal depth shall be measured to a distance of 6 inches below the bottom of the pipe in earth and 8 inches in rock.
- C. For concrete Resist Structure foundation, the normal width of the excavation shall be 24 inches outside the neat line of the concrete. The normal depth shall be 4 inches below the base of the foundation slab for the installation of the stabilization slab as shown on the Contract Drawings.
- D. For concrete placed directly against undisturbed earth, the normal width and depth of the excavation for such concrete shall be measured to the neat lines of the concrete as indicated on the Contract Drawings or as ordered.
- E. For concrete placed against rock surfaces resulting from rock excavation, the normal width and depth of the excavation shall be measured to 4 inches outside the neat lines of the concrete as indicated on the Contract Drawings or as ordered.
- F. For other structures, including catch basins and manholes, the normal width shall be measured 1 foot outside the neat lines of the widest part of the structure. The normal depth shall be measured to the underside of that part of the structure plus stone bedding shown on the details, for which the excavation is made.

1.07 ADDITIONAL EXCAVATION

- A. The quantity of earth excavation outside the normal width or depth (limit of normal excavation) to be included for payment under this item shall be the number of additional cubic yards excavated, measured to the depths and lengths ordered by the Construction Manager.

1.08 SUBSURFACE UTILITY EXPLORATIONS, AND EXCAVATION OF TEST PITS, IF AND WHERE DIRECTED

- A. The number of subsurface utility explorations (SUE), and the quantity of excavation to be paid for under the respective items shall be the number SUE's and the quantity of cubic yards excavated per test pit, measured to the extent of the work done as directed by the Construction Manager. Material excavated during test pit activities will be returned into the excavation upon acceptance by the Construction Manager. Excavated material will be returned in the reverse order it was removed (i.e., most recently excavated material returned first). All work shall conform to Section 312300 Excavation and Fill.

1.09 EXCAVATION OF TEST PITS, ARCHEOLOGICAL INVESTIGATION

- A. The quantity of excavation for test pits for archeological investigations are to be paid for under this item shall be based on the size and depths of test pits identified under the Field Testing Plan for the New Jersey State Historic Preservation Office as directed by the Construction Manager. Material excavated during test pit activities will be returned into the excavation upon acceptance by the Construction Manager. Excavated material will be returned in the reverse order it was removed (i.e., most recently excavated material returned first). All work shall conform to Section 312300 Excavation and Fill.
- B. The Construction Manager will direct the Contractor's excavator to excavate in a slow and controlled manner and have the ability to stop the excavator during the excavation process to record the excavation and to photo document the excavation and excavated materials. The Contractor shall provide access for the archaeologist to hand dig within the excavation if necessary. The excavation shall measure approximately 3LF wide X 10LF long. Archeological investigations shall be concluded at the depth of the resource or the depth of construction, which ever depth is achieved first. Refer to Section 013443 for Archeologist Excavation Locations.

1.10 SHEETING LEFT IN PLACE, IF AND WHERE DIRECTED

- A. The quantity of sheeting left in place is to be paid for under this bid item as directed by the Construction Manager and shall be measured by the square foot.
- B. The number of square feet of sheeting to be measured shall be ONLY that left in place, as specified above. No measurement shall be made for sheeting, bracing, and coffer damming which is left in place at the option of the Contractor or which is removed from the excavation, it being understood and agreed that the compensation for all such sheeting and for cost of furnishing, placing, cutting, and removal thereof is included in the price to be paid for the items involving earth excavation for which sheeting is used.
- C. The unit price or prices for this item shall constitute full compensation for all sheeting including bracing and other accessories left in place as specified.

1.11 PAVEMENT

- A. The unit price for DGA-base course shall constitute full compensation for furnishing material for DGA-base course as specified and as indicated on the drawings or as directed by the Construction Manager, and within payment limits. Placing and compacting the DGA-base course will be paid for under the Line Item for Roadway Base Course, DGA.
- B. The unit price for base course pavement shall constitute full compensation for constructing and maintaining the base course pavement, as specified and as indicated on the drawings or as directed by the Construction Manager. Base course pavement shall be maintained and repaired as directed by the Construction Manager until the surface pavement course is installed.
- C. The unit price or prices for top course pavement shall constitute full compensation for milling the pavement to a depth of 2 inches minimum, and constructing the surface course pavement, as specified and as indicated. Top course shall not be installed by the Contractor until directed by the Construction Manager.
- D. The area of work contains several areas of historically significant brick pavers and cobblestone paver roadways. All such brick pavers and cobblestone roadways in the work area, whether exposed or covered, are to be removed without mechanical equipment and safely stored by the Contractor. The Contractor shall remove only the minimum number of pavers required to perform the work. Temporary bituminous pavement, a minimum of 4 inches thick, shall be placed on the trench surface until the Construction Manager directs the Contractor to re-install the removed cobblestone pavers. The temporary pavement is to be removed and paver installed per the details. Cobblestone pavers broken or lost by the Contractor are to be replaced in kind by the Contractor. Replacement pavers are to be matched in size, color and texture to the original pavers and be approved by the Construction Manager prior to installation. The cost to remove, store, install and remove temporary pavement, supplement damaged or lost pavers, and reinstall pavers is to be included in these items.
- E. Placement of temporary pavement markings and permanent placement of pavement markings (all types), as shown on the drawings, including costs of all tools, labor, equipment, materials, traffic control, protection of pavement markings against traffic and weather and any incidentals necessary for the installation of the pavement markings shown on the drawings as required shall be included in the Line Item for Roadway Top Course, Hot Mix Asphalt. The price shall be full compensation for all pavement markings of all sizes and colors required. Pavement markings replaced must be approved and accepted by the respective Municipality and/or Hudson County prior to payment.
 - 1. Application of equivalent temporary markings shall be placed after temporary restoration is placed and roadways are reopened to traffic.

1.12 SERVICES OF UNIFORMED SPECIAL OFFICERS

- A. Under this item, the Contractor shall be reimbursed for certain charges for the services of uniformed special officers (shown as traffic enforcement agents on the MPT plans) rendered in connection with traffic control, as noted on the Contract Drawings or as required by the Municipalities, New Jersey Transit or the Port Authority of New York and New Jersey.
- B. An allowance for this item with an established bid amount of \$3,100,000.00 is included in the bid items. Contractor shall not modify or change this amount in its Bid.
- C. The actual amount to be paid under this item shall consist of the contractual hourly rate. The Contractor will be responsible for coordinating with the Municipalities to set up payment terms and accounts as required. The Contractor will be required to submit sufficient backup to DEP, including paid invoices or cancelled checks from the Municipalities, plus daily officer sign-in logs, including names, start and end times, and work zone locations of the officers working each day.

1.13 URBAN AMENITIES

- A. This Project provides for the enhancement of the concrete floodwall with the structures, signage, plantings and surface treatments detailed in Plan Sheets designated URBAN AMENITIES.
- B. The cost for the work shown on these plan sheets is to be paid for under a lump sum item and is to cover only the additional work specifically shown and needed to provide, install, and test those items. The floodwall foundation, stem wall, gates, and other work called out elsewhere in the Contract Documents, including any temporary restoration required, is not part of this pay items and the cost of those items is to be included under other pay items. Wall form liners are to be paid for under Item 3C: Concrete Resist Structure Walls – Concrete Wall.

1.14 COVE PARK OPTIONS A & B

- A. This Project provides for the construction of new park facilities. The proposed Cove Park improvements will consist of two (2) bid items. The first bid item shall be bid as part of the Base Contract and a second Add/Alternate 1 bid item will include additional park amenities and facilities. Item 32: Cove Park Improvement Option A (Base Park) will be incorporated into the Base Contract as the “Base Park” and is defined in plan sheets designated COVE PARK OPT A – BASE PARK.
- B. Add/Alt Item 1: Cove Park Improvement Option B (Full Park) will be bid as an Add/Alternate item to the Contract and is considered the “Full Park” and is defined in plan sheets designated COVE PARK OPT B – FULL PARK.
 - 1. Item shall be inclusive of all structures, landscaping, drainage, fill materials and placement, load transfer platforms, plantings, surface treatments, retaining walls,

pedestrian bridge, wall treatments and other specified items shown unless explicitly covered under other Items. The cost for the work shown on these plan sheets is to be paid for under a lump sum item and is to cover only the additional work specifically shown and needed to provide, install and test for the lump sum item.

2. This Item is for all work required in addition to the Base Park work. As such, when determining the bid cost for the Full Park the Contractor shall not include costs for all work shown on the Plan Sheets designated COVE PARK OPT A – BASE PARK to avoid duplication of costs already included in the Base Park work.
 3. For example, items such as site demolition, load transfer platform, and column supported embankment shall be included in the Base Park bid item because those items are to be completed as a part of the Base Park work. These items are also shown on the Full Park plan sheets. Therefore, when determining the bid cost for the Full Park the Contractor shall not include the costs for these specific items. Please note the items above are not a complete list of duplicative items and are only listed to provide examples and attempt to offer clarity.
 4. There may be components in the Base Park that may require additional effort should the Full Park be implemented (items such as, but not limited to irrigation system, concrete pathways, railings, etc.). The Contractor shall include the incremental increase in cost for the work in the Add/Alt bid item for the Full Park and place the original cost in the Base bid. These items shall not be duplicated within the Add/Alt bid item work. Any work that is a component of Item 32: Cove Park Improvement Option A (Base Park) that will not be performed due to the execution of Add/Alt Item 1: Cove Park Improvement Option B (Full Park) shall not be included in the lump sum price of Add/Alt Item 1: Cove Park Improvement Option B (Full Park).
- C. All elements including the floodwall foundation, stem wall, formliners, gates, and other work called out elsewhere in the Contract Documents, including any temporary restoration required, is not part of this pay items and the cost of those items is to be included under other pay items. Wall formliners are to be paid for under Item 3C: Concrete Resist Structure Walls – Concrete Wall.
- D. All costs of temporary and final restoration required during the construction of Item 32: Cove Park Improvement Option A (Base Park), or Add/ALT Item 1: Cove Park Improvement Option B (Full Park), within the Limits of Disturbance shown on the drawings, shall be included in the respective Lump Sum amounts bid. No other payment will be made under unit or lump sum items unless such additional work is directed by the Construction Manager.
- 1.15 SUBSURFACE UTILITY EXPLORATION
- A. The Contractor is to provide the services of a pre-qualified utility locating service to provide Quality A level utility locations as required by the Contractor and approved by the Construction Manager. Quality Level A, also known as "locating", is the highest level

of accuracy presently available and involves the full use of the subsurface utility engineering services. It provides information for the precise plan and profile mapping of underground utilities through the nondestructive exposure of underground utilities, and also provides the type, size, condition, material and other characteristics of underground features.

1.16 MOBILIZATION

- A. The lump sum price for this item shall constitute full compensation for all tasks related to project mobilization and as specified and as indicated in this Section paragraph 3.01.A, and not specifically paid for under other items. De-mobilization costs will not be paid separately but shall be included in the cost of the work.

1.17 EXTRA WORK

- A. Extra work, if any, shall be performed in accordance with Article 10 of the General Conditions and will be paid for in accordance with Article 11 of the General Conditions.

1.18 PERMITTING

- A. Contractor shall not be responsible for road opening permit fees for the City of Hoboken, Township of Weehawken, and Hudson County and therefore shall not include costs for these items in their bid amount. The Contractor will be responsible for all other requirements in obtaining said road opening permits with the exception of the fees.
- B. No separate payment shall be made for any other permit fees, application fees, and associated governmental fees, licenses and inspections necessary for the proper execution and completion of the Work, and which are legally required at the time of receipt of the bid. No separate payment shall be made for the Contractor's implementation of their dewatering plan or dewatering activities. Dewatering activities, including the use and installation of monitoring instrumentation, shall be considered incidental to the payment item that requires dewatering. Payment shall include in the unit prices or lump sum prices for the respective payment item requiring Dewatering, in accordance with Section 012901.

PART 2 - PRODUCTS (NOT USED)

PART 3 - EXECUTION

3.01 SCHEDULE OF BID PRICES

- A. Item 1: Mobilization/Demobilization

- 1. Description: All tasks related to the mobilization of personnel, equipment and materials to/from the work site for other contract items that will be performed by

the Contractor. Mobilization shall include, but not be limited to, the movement of equipment, personnel, material, supplies, etc. to/from the Work site. Payment for bonds, insurance, etc. is also covered under this item. Unless specifically covered under other Contract Items, all costs required to comply with; the General Conditions, the Supplemental General Conditions and Division 1 of the Contract Sections, are included under the lump sum price bid for Mobilization. These items include, but are not limited to: the establishment of field offices and other temporary facilities; clearing; scheduling; construction photographs and videotapes; permits required to be obtained by the Contractor; project closeout and record items; and providing professional construction surveying services for project layout and as-built information.

2. Costs to provide Soil Erosion and Sediment Control as shown on the Plans, in accordance with Section 015713, and as required by the Hudson-Passaic-Essex Soil Conservation District are to be included in this Item. The costs to protect trees during construction are also to be included in this Item as shown on the Plans and in accordance with Section 015639.
3. Costs to prepare, submit, maintain, and update an Operations and Maintenance Manual in accordance with Section 017823 are to be included in this item.
4. Cost to prepare the following reports are to be included in this Item, all reports are to be submitted to the Construction Manager for review and approval prior to the Contractor mobilizing to the project. The Contractor will not be permitted to proceed with mobilization until the plans listed below are complete and accepted by the NJDEP.
 - a. Project Logistics Plan – this plan will cover work staging, access, restricted areas, Contractor office trailer location, storage areas, site safety and security. Obtaining approved storage, staging, and office trailer locations are the full responsibility of the Contractor.
 - b. The Contractor Health and Safety Plan – a Project specific plan that is consistent with the Occupational Safety and Health Act (OSHA) requirements. The Plan will address on-site and off-site health and safety issues, and emergency notifications and procedures. Contractor is solely responsible for ensuring and providing all the safety gear/ PPE to the workers on site.
 - c. Construction Quality Control and Assurance Plan – This Plan is to detail Project specific construction monitoring procedures to assure compliance with the Plans and Contract Sections. It shall include procedures for sampling, analytical testing, data validation and reporting requirements for on-site and off-site testing of materials to be incorporated into the work.

- d. Materials Management Plan – The Contractor shall prepare a (MMP) to address the management of regulated materials on the Project Site in accordance to Section 013443. The MMP will include, at a minimum; the methods to sample and characterize excess soils, dispose of excess material and soils, identification of off-site licensed disposal/recycling facilities, stockpiling and staging requirements, excavated soil management procedures, free product procedures, backfilling and capping, and equipment/vehicle decontamination procedures. The MMP shall also address the means and methods for handling, treatment, and disposal of contaminated groundwater, if encountered, as well as a description of how the Contractor will control environmental disturbances during construction and contingency measures for controlling potential spills from construction and operational activities.
- e. Construction Vibration Control Monitoring and Settlement Monitoring Plans. Plans shall be prepared in accordance to the procedures outlined in Section 023214. Payment for performing monitoring shall be paid under Item 38: Air, Noise, Dust, Vibration and Settlement Monitoring.
- f. A separate plan shall be prepared and submitted to monitor vibration and settlement in the Port Authority Trans Hudson (PATH) tunnels. This plan will be reviewed and approved by the Port Authority (PA) and PATH. Contractor is to allow sufficient time for PA and PATH review and approve so as to not delay any work in the tunnel vicinity. Payment for performing monitoring shall be paid under Item 38: Air, Noise, Dust, Vibration and Settlement Monitoring.
- g. Noise Control and Mitigation Plan. Plan shall be prepared in accordance to Section 023124. Payment for performing monitoring shall be paid under Item 38: Air, Noise, Dust, Vibration and Settlement Monitoring.
- h. Storm Water Management Plan to meet NJDEP stormwater regulations
- i. Pre-construction nest survey to identify active bird nests of nesting birds identified to be protected under the US fish and Wildlife’s Migratory Bird Treaty Act.
- j. Preconstruction photos and videos in accordance with General Conditions Article 4.
- k. Maintenance of Traffic Control Plan. This plan shall detail project specific maintenance and protection of traffic (MPT) measures to assure compliance with the Plans and Specifications. Contractor MPT Plans shall be coordinated with the City of Hoboken, New Jersey Transit, and all stakeholders of public and private entities impacted by the Work. Plan shall be approved by the City of Hoboken prior to commencement of construction. Costs to implement the

MPT measures shall be paid under Item 37: Maintenance and Protection of Traffic.

1. Utility Emergency Action Plan - Contractor shall prepare an Emergency Action Plan (UEAP) to address disruption or damage to utilities encountered during the work. Plan shall detail points of contact to each utility owner, designate a notification and response time to address the potential issue, and detail corrective actions to be performed to repair the damaged utility.
 - m. Update the inspections and reports on the daily report forms maintained by the Construction Management Firm (CMF) team. If the inspection identifies incidents of noncompliance by the inspector or the Engineer of Record permit, then the Contractor shall implement corrective actions and record when the action was performed.
5. Payment: This Item is limited to three and five-tenths (3.5%) percent of the Total Bid Cost. Mobilization shall be paid for under the following schedule;
- a. Twenty-five (25%) percent of Mobilization Lump Sum to be paid at five (5%) percent total project approved payment request, exclusive of the Mobilization Lump Sum price. The total project value shall be calculated to include the awarded contract value plus the value of all Change Orders registered at the time of the payment cut-off date.
 - b. Additional twenty-five (25%) percent of Mobilization Lump Sum to be paid at ten (10%) percent total project approved payment request, exclusive of the Mobilization Lump Sum price.
 - c. Remainder of Mobilization Lump Sum less \$1,000,000 to be paid at fifteen (15%) percent total project approved payment request, exclusive of the Mobilization Lump Sum price.
 - d. The final \$1,000,00.00, held in this item, will be paid once substantial completion has been awarded to the Contractor and with the approval of the State and Construction Manager.

B. Item 2: Temporary Facilities Maintenance

1. Description: Maintenance of the temporary facilities, for the time required, shall consist of maintaining the user utilities (sewer, water, electric, temporary heat), project identification, temporary facilities (field offices, fencing, sheds, office for Construction Manager), equipment, support facility installation, security and protection, operation, rodent and mosquito surveillance and control, termination of services, and removal as described in General Conditions Article 4.12 – Temporary Facilities and Contract Section 015000 of the field offices/ Construction Manager offices shall include the monthly rent. The field/ Construction Manager office

equipment shall be repaired or replaced within 48 hours of becoming inoperable or defective. Equipment should be maintained in working order for the duration of the contract.

2. Payment shall be on a monthly rate for the duration of the Project or until the Contractor is directed by the Construction Manager to remove all temporary facilities.

C. Item 3A: Concrete Resist Structure Walls – Removals & Utility Work

1. Description: This Item will include all Work related to demolition, removal, disposal, and utility work in order to construct concrete Resist Structure walls.
 - a. This Item includes, but is not limited to, all removals and disposal required to perform the work as shown on the plans: unclassified excavation for the foundations, excavation support, asphalt pavement removal, concrete sidewalk and curb removal, paver removal, street sign removal and replacement, hydrant removal and abandonment, guide rail removal, meter removal and replacement, dewatering, shoring, inspections, soil testing and classification, and all vegetative removals. Price to include all materials, labor, disposal, and equipment necessary to perform the work.
 - b. This item will include implementation, frequency and schedule date/ dates of inspections in relation to the progress schedule.
 - c. This Item includes, but is not limited to, drainage system abandonment, location and protection of existing utilities, utility relocation of known utilities as shown on the Contract Drawings, new manholes, inlets, catch basins, roadway and sidewalk trench drains, valves, culverts, cleanouts, temporary diversions, backfill, and pipes as shown on the plans. In addition, a 30-inch and 20-inch water main bypass near Station 303+00 shall be included in the cost of this item. Price to include all materials, labor, and equipment necessary to perform the work.
 - d. This Item will include costs for all other work needed to complete the installation and not specifically noted in other items.
2. Lump Sum payment under this Item will constitute full compensation for all work and costs to perform and complete the various types of demolitions, removals, and utilities to construct concrete resist structures with the exception of allowances and unit price contract items.

D. Item 3B: Concrete Resist Structure Walls – Restoration

1. Description: This Item will include all Work related to restoration in order to construct concrete Resist Structure walls.

- a. This item will include implementation, frequency and schedule date/ dates of inspections in relation to the progress schedule.
 - b. This Item includes, but is not limited to, restoration of all disturbed areas to the reasonable satisfaction of the property owners, including replacement in kind of trees, shrubs, topsoil, and grass seeding of disturbed areas. Price to include all materials, labor, and equipment necessary to perform the work.
 - c. This Item includes, but is not limited to, the installation of bollards as depicted on the Contract Drawings. Price to include all materials, labor, and equipment necessary to perform the work.
 - d. This Item will include costs for all other work needed to complete the installation and not specifically noted in other items.
2. Lump Sum payment under this Item will constitute full compensation for all work and costs to perform and complete the various types of restoration to construct concrete resist structures with the exception of allowances and unit price contract items.

E. Item 3C: Concrete Resist Structure Walls – Concrete Wall

1. Description: This Item will include all Work to construct concrete Resist Structure walls.
 - a. This item will include implementation, frequency and schedule date/ dates of inspections in relation to the progress schedule.
 - b. This Item includes, but is not limited to, all components required to fully construct the concrete resist structure walls, including but not limited to, the concrete, reinforcement, forms, formliners, falsework, and foundations under the gate structures. Price to include all materials, labor, and equipment necessary to perform the work. The end pilasters, and track, guides or intermediate support posts are to be paid for under the appropriate Bid Item 4A thru 4CC for Resist Structure Gates and Appurtenances.
 - c. This Item will include costs for all other work needed to complete the installation and not specifically noted in other items.
2. Lump Sum payment under this Item will constitute full compensation for all work and costs to perform and complete the various types of concrete resist structures with the exception of allowances and unit price contract items.

F. Item 4A: Resist Structure Gate SG-1 and Appurtenances

1. Description: Provide and install the Gate structure required by the Contract and not specifically covered by other items. Price to include all materials and labor,

fabrication and transportation to the site, including embedded seals, sills and bearing plates, bearing bars, hinges, bracing bars, latching devices, central posts and covers, lintel beams, and all other incidentals required for a complete project meeting the Contract Documents.

2. Lump Sum payment under this Item will constitute full compensation for all work and costs to perform and complete the Resist structure gate and appurtenances with the exception of allowances and unit price contract items.

G. Item 4B: Resist Structure Gate SG-2 and Appurtenances

1. Description: Provide and install the Gate structure required by the Contract and not specifically covered by other items. Price to include all materials and labor, fabrication and transportation to the site, including embedded seals, sills and bearing plates, bearing bars, hinges, bracing bars, latching devices, central posts and covers, lintel beams, and all other incidentals required for a complete project meeting the Contract Documents.
2. Lump Sum payment under this Item will constitute full compensation for all work and costs to perform and complete the Resist structure gate and appurtenances with the exception of allowances and unit price contract items.

H. Item 4C: Resist Structure Gate SG-3 and Appurtenances

1. Description: Provide and install the Gate structure required by the Contract and not specifically covered by other items. Price to include all materials and labor, fabrication and transportation to the site, including embedded rolling paths, runways, stabilizing rollers, track guides, embedded bearing plates, rubber seals, removable stabilizing guides intermediate posts and covers, concrete pilaster supports, winches, transfer sheaves, and all other incidentals required for a complete project meeting the Contract Documents.
2. Lump Sum payment under this Item will constitute full compensation for all work and costs to perform and complete the Resist structure gate and appurtenances with the exception of allowances and unit price contract items.

I. Item 4D: Resist Structure Gate SG-4 and Appurtenances

1. Description: Provide and install the Gate structure required by the Contract and not specifically covered by other items. Price to include all materials and labor, fabrication and transportation to the site, including embedded rolling paths, runways, stabilizing rollers, track guides, embedded bearing plates, rubber seals, removable stabilizing guides intermediate posts and covers, concrete pilaster supports, winches, transfer sheaves, and all other incidentals required for a complete project meeting the Contract Documents.

2. Lump Sum payment under this Item will constitute full compensation for all work and costs to perform and complete the Resist structure gate and appurtenances with the exception of allowances and unit price contract items.

J. Item 4E: Resist Structure Gate SG-5 and Appurtenances

1. Description: Provide and install the Gate structure required by the Contract and not specifically covered by other items. Price to include all materials and labor, fabrication and transportation to the site, including embedded rolling paths, runways, stabilizing rollers, track guides, embedded bearing plates, rubber seals, removable stabilizing guides intermediate posts and covers, concrete pilaster supports, winches, transfer sheaves, and all other incidentals required for a complete project meeting the Contract Documents.
2. Lump Sum payment under this Item will constitute full compensation for all work and costs to perform and complete the Resist structure gate and appurtenances with the exception of allowances and unit price contract items.

K. Item 4F: Resist Structure Gate SG-6 and Appurtenances

1. Description: Provide and install the Gate structure required by the Contract and not specifically covered by other items. Price to include all materials and labor, fabrication and transportation to the site, including embedded rolling paths, runways, stabilizing rollers, track guides, embedded bearing plates, rubber seals, removable stabilizing guides intermediate posts and covers, concrete pilaster supports, winches, transfer sheaves, and all other incidentals required for a complete project meeting the Contract Documents.
2. Lump Sum payment under this Item will constitute full compensation for all work and costs to perform and complete the Resist structure gate and appurtenances with the exception of allowances and unit price contract items.

L. Item 4G: Resist Structure Gate SG-7 and Appurtenances

1. Description: Provide and install the Gate structure required by the Contract and not specifically covered by other items. Price to include all materials and labor, fabrication and transportation to the site, including embedded rolling paths, runways, stabilizing rollers, track guides, embedded bearing plates, rubber seals, removable stabilizing guides intermediate posts and covers, concrete pilaster supports, winches, transfer sheaves, and all other incidentals required for a complete project meeting the Contract Documents.
2. Lump Sum payment under this Item will constitute full compensation for all work and costs to perform and complete the Resist structure gate and appurtenances with the exception of allowances and unit price contract items.

M. Item 4H: Resist Structure Gate SG-8 and Appurtenances

1. Description: Provide and install the Gate structure required by the Contract and not specifically covered by other items. Price to include all materials and labor, fabrication and transportation to the site, including embedded rolling paths, runways, stabilizing rollers, track guides, embedded bearing plates, rubber seals, removable stabilizing guides intermediate posts and covers, concrete pilaster supports, winches, transfer sheaves, and all other incidentals required for a complete project meeting the Contract Documents.
2. Lump Sum payment under this Item will constitute full compensation for all work and costs to perform and complete the Resist structure gate and appurtenances with the exception of allowances and unit price contract items.

N. Item 4I: Resist Structure Gate SG-9 and Appurtenances

1. Description: Provide and install the Gate structure required by the Contract and not specifically covered by other items. Price to include all materials and labor, fabrication and transportation to the site, including embedded rolling paths, runways, stabilizing rollers, track guides, embedded bearing plates, rubber seals, removable stabilizing guides intermediate posts and covers, concrete pilaster supports, winches, transfer sheaves, and all other incidentals required for a complete project meeting the Contract Documents.
2. Lump Sum payment under this Item will constitute full compensation for all work and costs to perform and complete the Resist structure gate and appurtenances with the exception of allowances and unit price contract items.

O. Item 4J: Resist Structure Gate SG-10 and Appurtenances

1. Description: Provide and install the Gate structure required by the Contract and not specifically covered by other items. Price to include all materials and labor, fabrication and transportation to the site, including embedded seals, sills and bearing plates, bearing bars, hinges, bracing bars, latching devices, central posts and covers, lintel beams, and all other incidentals required for a complete project meeting the Contract Documents.
2. Lump Sum payment under this Item will constitute full compensation for all work and costs to perform and complete the Resist structure gate and appurtenances with the exception of allowances and unit price contract items.

P. Item 4K: Resist Structure Gate SG-11 and Appurtenances

1. Description: Provide and install the Gate structure required by the Contract and not specifically covered by other items. Price to include all materials and labor, fabrication and transportation to the site, including embedded seals, sills and bearing plates, bearing bars, hinges, bracing bars, latching devices, central posts

and covers, lintel beams, and all other incidentals required for a complete project meeting the Contract Documents.

2. Lump Sum payment under this Item will constitute full compensation for all work and costs to perform and complete the Resist structure gate and appurtenances with the exception of allowances and unit price contract items.

Q. Item 4L: Resist Structure Gate SG-12 and Appurtenances

1. Description: Provide and install the Gate structure required by the Contract and not specifically covered by other items. Price to include all materials and labor, fabrication and transportation to the site, including embedded rolling paths, runways, stabilizing rollers, track guides, embedded bearing plates, rubber seals, removable stabilizing guides intermediate posts and covers, concrete pilaster supports, winches, transfer sheaves, and all other incidentals required for a complete project meeting the Contract Documents.
2. Lump Sum payment under this Item will constitute full compensation for all work and costs to perform and complete the Resist structure gate and appurtenances with the exception of allowances and unit price contract items.

R. Item 4M: Resist Structure Gate SG-13 and Appurtenances

1. Description: Provide and install the Gate structure required by the Contract and not specifically covered by other items. Price to include all materials and labor, fabrication and transportation to the site, including embedded seals, sills and bearing plates, bearing bars, hinges, bracing bars, latching devices, central posts and covers, lintel beams, and all other incidentals required for a complete project meeting the Contract Documents.
2. Lump Sum payment under this Item will constitute full compensation for all work and costs to perform and complete the Resist structure gate and appurtenances with the exception of allowances and unit price contract items.

S. Item 4N: Resist Structure Gate SSG-1 and Appurtenances

1. Description: Provide and install the Gate structure required by the Contract and not specifically covered by other items. Price to include all materials and labor, fabrication and transportation to the site, including embedded rolling paths, runways, stabilizing rollers, track guides, embedded bearing plates, rubber seals, removable stabilizing guides intermediate posts and covers, concrete pilaster supports, winches, transfer sheaves, and all other incidentals required for a complete project meeting the Contract Documents.
2. Lump Sum payment under this Item will constitute full compensation for all work and costs to perform and complete the Resist structure gate and appurtenances with the exception of allowances and unit price contract items.

T. Item 4O: Resist Structure Gate SSG-2 and Appurtenances

1. Description: Provide and install the Gate structure required by the Contract and not specifically covered by other items. Price to include all materials and labor, fabrication and transportation to the site, including embedded rolling paths, runways, stabilizing rollers, track guides, embedded bearing plates, rubber seals, removable stabilizing guides intermediate posts and covers, concrete pilaster supports, winches, transfer sheaves, and all other incidentals required for a complete project meeting the Contract Documents.
2. Lump Sum payment under this Item will constitute full compensation for all work and costs to perform and complete the Resist structure gate and appurtenances with the exception of allowances and unit price contract items.

U. Item 4P: Resist Structure Gate SSG-3 and Appurtenances

1. Description: Provide and install the Gate structure required by the Contract and not specifically covered by other items. Price to include all materials and labor, fabrication and transportation to the site, including embedded rolling paths, runways, stabilizing rollers, track guides, embedded bearing plates, rubber seals, removable stabilizing guides intermediate posts and covers, concrete pilaster supports, winches, transfer sheaves, and all other incidentals required for a complete project meeting the Contract Documents.
2. Lump Sum payment under this Item will constitute full compensation for all work and costs to perform and complete the Resist structure gate and appurtenances with the exception of allowances and unit price contract items.

V. Item 4Q: Resist Structure Gate SSG-4 and Appurtenances

1. Description: Provide and install the Gate structure required by the Contract and not specifically covered by other items. Price to include all materials and labor, fabrication and transportation to the site, including embedded rolling paths, runways, stabilizing rollers, track guides, embedded bearing plates, rubber seals, removable stabilizing guides intermediate posts and covers, concrete pilaster supports, winches, transfer sheaves, and all other incidentals required for a complete project meeting the Contract Documents.
2. Lump Sum payment under this Item will constitute full compensation for all work and costs to perform and complete the Resist structure gate and appurtenances with the exception of allowances and unit price contract items.

W. Item 4R: Resist Structure Gate NG-1 and Appurtenances

1. Description: Provide and install the Gate structure required by the Contract and not specifically covered by other items. Price to include all materials and labor, fabrication and transportation to the site, including embedded sills, rubber base

seals side frames, pad lockable compression clamps stop logs and all other incidentals required for a complete project meeting the Contract Documents.

2. Lump Sum payment under this Item will constitute full compensation for all work and costs to perform and complete the Resist structure gate and appurtenances with the exception of allowances and unit price contract items.

X. Item 4S: Resist Structure Gate NG-2 and Appurtenances

1. Description: Provide and install the Gate structure required by the Contract and not specifically covered by other items. Price to include all materials and labor, fabrication and transportation to the site, including embedded rolling paths, runways, stabilizing rollers, track guides, embedded bearing plates, rubber seals, removable stabilizing guides intermediate posts and covers, concrete pilaster supports, winches, transfer sheaves, and all other incidentals required for a complete project meeting the Contract Documents.
2. Lump Sum payment under this Item will constitute full compensation for all work and costs to perform and complete the Resist structure gate and appurtenances with the exception of allowances and unit price contract items.

Y. Item 4T: Resist Structure Gate NG-3 and Appurtenances

1. Description: Provide and install the Stop Log Gate structure required by the Contract and not specifically covered by other items. Price to include all materials and labor, fabrication and transportation to the site, including embedded sills, rubber base seals side frames, pad lockable compression clamps stop logs and all other incidentals required for a complete project meeting the Contract Documents.
2. Lump Sum payment under this Item will constitute full compensation for all work and costs to perform and complete the Resist structure gate and appurtenances with the exception of allowances and unit price contract items.

Z. Item 4U: Resist Structure Gate NG-5 and Appurtenances

1. Description: Provide and install the Gate structure required by the Contract and not specifically covered by other items. Price to include all materials and labor, fabrication and transportation to the site, including embedded rolling paths, runways, stabilizing rollers, track guides, embedded bearing plates, rubber seals, removable stabilizing guides intermediate posts and covers, concrete pilaster supports, winches, transfer sheaves, and all other incidentals required for a complete project meeting the Contract Documents.
2. Lump Sum payment under this Item will constitute full compensation for all work and costs to perform and complete the Resist structure gate and appurtenances with the exception of allowances and unit price contract items.

AA. Item 4V: Resist Structure Gate NG-6 and Appurtenances

1. Description: Provide and install the Gate structure required by the Contract and not specifically covered by other items. Price to include all materials and labor, fabrication and transportation to the site, including embedded seals, sills and bearing plates, bearing bars, hinges, bracing bars, latching devices, central posts and covers, lintel beams, and all other incidentals required for a complete project meeting the Contract Documents.
2. Lump Sum payment under this Item will constitute full compensation for all work and costs to perform and complete the Resist structure gate and appurtenances with the exception of allowances and unit price contract items.

BB. Item 4W: Resist Structure Gate NG-7 and Appurtenances

1. Description: Provide and install the Gate structure required by the Contract and not specifically covered by other items. Price to include all materials and labor, fabrication and transportation to the site, including embedded rolling paths, runways, stabilizing rollers, track guides, embedded bearing plates, rubber seals, removable stabilizing guides intermediate posts and covers, concrete pilaster supports, winches, transfer sheaves, and all other incidentals required for a complete project meeting the Contract Documents.
2. Lump Sum payment under this Item will constitute full compensation for all work and costs to perform and complete the Resist structure gate and appurtenances with the exception of allowances and unit price contract items.

CC. Item 4X: Resist Structure Gate NG-8 and Appurtenances

1. Description: Provide and install the Gate structure required by the Contract and not specifically covered by other items. Price to include all materials and labor, fabrication and transportation to the site, including embedded rolling paths, runways, stabilizing rollers, track guides, embedded bearing plates, rubber seals, removable stabilizing guides intermediate posts and covers, concrete pilaster supports, winches, transfer sheaves, and all other incidentals required for a complete project meeting the Contract Documents.
2. Lump Sum payment under this Item will constitute full compensation for all work and costs to perform and complete the Resist structure gate and appurtenances with the exception of allowances and unit price contract items.

DD. Item 4Y: Resist Structure Gate NG-9 and Appurtenances

1. Description: Provide and install the Gate structure required by the Contract and not specifically covered by other items. Price to include all materials and labor, fabrication and transportation to the site, including embedded rolling paths, runways, stabilizing rollers, track guides, embedded bearing plates, rubber seals,

removable stabilizing guides intermediate posts and covers, concrete pilaster supports, winches, transfer sheaves, and all other incidentals required for a complete project meeting the Contract Documents.

2. Lump Sum payment under this Item will constitute full compensation for all work and costs to perform and complete the Resist structure gate and appurtenances with the exception of allowances and unit price contract items.

EE. Item 4Z: Resist Structure Gate NG-10 and Appurtenances

1. Description: Provide and install the Gate structure required by the Contract and not specifically covered by other items. Price to include all materials and labor, fabrication and transportation to the site, including embedded seals, sills and bearing plates, bearing bars, hinges, bracing bars, latching devices, central posts and covers, lintel beams, and all other incidentals required for a complete project meeting the Contract Documents.
2. Lump Sum payment under this Item will constitute full compensation for all work and costs to perform and complete the Resist structure gate and appurtenances with the exception of allowances and unit price contract items.

FF. Item 4AA: Resist Structure Gate NG-11 and Appurtenances

1. Description: Provide and install the Gate structure required by the Contract and not specifically covered by other items. Price to include all materials and labor, fabrication and transportation to the site, including embedded rolling paths, runways, stabilizing rollers, track guides, embedded bearing plates, rubber seals, removable stabilizing guides intermediate posts and covers, concrete pilaster supports, winches, transfer sheaves, and all other incidentals required for a complete project meeting the Contract Documents.
2. Lump Sum payment under this Item will constitute full compensation for all work and costs to perform and complete the Resist structure gate and appurtenances with the exception of allowances and unit price contract items.

GG. Item 4BB: Resist Structure Gate SG-3A and Appurtenances

1. Description: Provide and install the Gate structure required by the Contract and not specifically covered by other items. Price to include all materials and labor, fabrication and transportation to the site, including embedded seals, sills and bearing plates, bearing bars, hinges, bracing bars, latching devices, central posts and covers, lintel beams, and all other incidentals required for a complete project meeting the Contract Documents.
2. Lump Sum payment under this Item will constitute full compensation for all work and costs to perform and complete the Resist structure gate and appurtenances with the exception of allowances and unit price contract items.

HH. Item 4CC: Resist Structure Sluice Gates (6), Flap Gates, Backflow Preventor, and Appurtenances

1. Description: Provide and install the various types of Gate structures required by the Contract and not specifically covered by other items. Price to include all materials and labor, fabrication and transportation to the site, including track guides, intermediate posts and covers, concrete pilaster supports, and all other incidentals required for a complete project meeting the Contract Documents.
2. Lump Sum payment under this Item will constitute full compensation for all work and costs to perform and complete the Resist structure sluice gates, flap gates, backflow preventor, and appurtenances with the exception of allowances and unit price contract items.

II. Item 5: Provide and Install H-Piles

1. Description: Provide and install H-piles required by the Contract and will include all labor and materials, equipment, pile driving plans, testing, reports and all incidentals required for a complete installation meeting the Contract Documents.
2. Payment shall be based on the actual length of H-Pile installed measured in linear feet and will not include any portion cut off at the surface.

JJ. Item 6: Provide and Install Micropiles 9-5/8-inch diameter

1. Description: Provide and install micropiles required by the Contract and will include all labor and materials, equipment, pile installation plans, testing, reports and all incidentals required for a complete installation meeting the Contract Documents.
2. Payment shall be based on the actual length of micropile installed measured in linear feet and will not include any portion cutoff at the surface.

KK. Item 7: Provide and Install Micropiles 11-7/8-inch diameter

1. Description: Provide and install micropiles required by the Contract and will include all labor and materials, equipment, pile installation plans, testing, reports and all incidentals required for a complete installation meeting the Contract Documents.
2. Payment shall be based on the actual length of micropile installed measured in linear feet and will not include any portion cutoff at the surface.

LL. Item 8: Provide and Install Micropiles 13-3/8-inch diameter

1. Description: Provide and install micropiles required by the Contract and will include all labor and materials, equipment, pile installation plans, testing, reports

and all incidentals required for a complete installation meeting the Contract Documents.

2. Payment shall be based on the actual length of micropile installed measured in linear feet and will not include any portion cutoff at the surface.

MM. Item 9: Provide and Install Sheetpile Cutoff Walls, PZ-22

1. Description: Provide and install PZ-22 sheetpile cutoff walls required by the Contract and will include all labor and materials, equipment, testing and all incidentals required for a complete installation meeting the Contract Documents.
2. Payment shall be based on the actual area of sheetpile installed measured in square feet and will not include any portion cut off at the surface.

NN. Item 10: Provide and Install Sheetpile I-Wall Support, PZ-27

1. Description: Provide and install PZ-27 I-Wall support sheetpile required by the Contract and will include all labor and materials, equipment, testing and all incidentals required for a complete installation meeting the Contract Documents.
2. Payment shall be based on the actual area of sheetpile installed measured in square feet and will not include any portion cut off at the surface.

OO. Item 11: Install Jet Grouting

1. Description: Provide and install jet grouting required by the Contract and will include all labor and materials, equipment, testing and all incidentals including the jet grouting work plan submission as required for a complete installation meeting the Contract Documents.
2. Payment shall be based on the actual quantity installed measured in cubic yards, verified by daily as-built log of installed material, as approved by the Construction Manager.

PP. Item 12: Excess Soil Disposal – Contaminated/Regulated Non-Hazardous

1. Description: Load, haul and dispose of excess soils and non-hazardous excavated materials encountered during excavation. Provide manifests, transport, and dispose of materials in accordance with New Jersey Department of Environmental Protection requirements and as required in the Contract Documents. Unit price to include testing, preparation of any manifests, bills of lading, waste characterization forms, or other documents necessary for shipment and disposal of non-hazardous excavation. Unit price to include any waste classification sampling required by the receiving facility and/or any treatment and disposal of the non-hazardous material at the identified facility, and any fees for disposal charged by the receiving facility. Excavated soils encountered outside the normal excavation limits that have not

been approved by the Construction Manager for additional excavation, as defined per Item 14: Additional Excavation - If and Where Directed, shall not be eligible for payment and shall be disposed of at the Contractor's expense.

2. Unit of Measure: Tons, as measured in truck, provided via material manifest, unless otherwise directed by the Construction Manager.

QQ. Item 13: Excess Soil Disposal – Hazardous or TSCA Regulated

1. Description: Load, haul and dispose of hazardous excavated materials encountered during excavation. Provide manifests, transport and dispose of materials in accordance with New Jersey Department of Environmental Protection requirements and as required in the Contract Documents. Unit price to include testing, preparation of any manifests, bills of lading, waste characterization forms, or other documents necessary for shipment and disposal of hazardous excavation. Unit price to include any waste classification sampling required by the receiving facility and/or any treatment and disposal hazardous material at the identified facility and any fees for disposal charged by the receiving facility. Excavated soils encountered outside the normal excavation limits that have not been approved by the Construction Manager for additional excavation, as defined per Item 14: Additional Excavation - If and Where Directed, shall not be eligible for payment and shall be disposed of at the Contractor's expense.
2. Unit of Measure: Tons, as measured in truck, provided via material manifest, unless otherwise directed by the Construction Manager.

RR. Item 14: Additional Excavation – If and Where Directed

1. Description: Excavation at the direction of the Construction Manager for any reason. Costs for disposal and fill will be covered by other items.
2. Payment shall be based on the neat cubic yards removed, measured in the excavation.

SS. Item 15: Additional Excavation – Rock/ Concrete, If and Where Directed

1. Description: Additional effort required to perform excavation when rock or concrete structures are encountered.
2. Rock shall be defined as material, natural or manmade, that requires hydraulic hammer to remove and has a volume one (1) cubic yard or greater. Blasting or chemical agents to break rock / concrete will not be allowed.
3. Load, haul and dispose of additional excavated rock / concrete materials. Provide manifests, transport and dispose of materials in accordance with New Jersey Department of Environmental Protection requirements and as required in the Contract Documents. Unit price to include preparation of any manifests, bills of

loading, waste characterization forms, or other documents necessary for shipment and disposal of non-hazardous excavation. Unit price to include any waste classification sampling required by the receiving facility and/or any treatment and disposal at the identified facility.

4. Unit of Measure: Cubic Yards of rock / concrete excavated, measured in-place immediately following excavation. Payment for additional rock excavation will be at the sole discretion of the Construction Manager and will only be made when the rock encountered during excavation has impeded the Contractor's typical production rates.

TT. Item 16: Structural Backfill – If and Where Directed

1. Description: Provide clean structural backfill as described in Section 312300 and at the direction of the Construction Manager. Cost to include placement and compaction of fill as required by the Contract Sections.
2. Unit of Measure: Tons, as measured in truck, provided via material manifest, unless otherwise directed by the Construction Manager.

UU. Item 17: Roadway Base Course, DGA

1. Description: Proof roll and prepare sub-grade. Furnish, place, grade and compact Dense Graded Aggregate (DGA) to a depth of not less than the depth as shown on the Contract Drawings, unless otherwise directed by the Construction Manager.
2. Unit of Measure: Tons, as measured in truck, provided via material manifest, unless otherwise directed by the Construction Manager.

VV. Item 18: Roadway Base Course, Hot Mix Asphalt

1. Description: Furnish, place, grade and compact Asphalt Base Course to a depth of not less than the depth as shown on the Contract Drawings, unless otherwise directed by the Construction Manager.
2. Unit of Measure: Tons, as measured in truck, provided via material manifest, unless otherwise directed by the Construction Manager.

WW. Item 19: Roadway Top Course, Hot Mix Asphalt

1. Description: When directed by the Construction Manager in areas shown on the Contract Drawings that require removal and replacement of pavement, mill off top 2 inches of pavement to the limits shown on the details, furnish, place, grade and compact Asphalt Top Course to a depth of not less than 2 inches, unless otherwise directed by the Construction Manager. In areas shown on the Contract Drawings that require new pavement installation or full depth pavement restoration, furnish, place, grade and compact Asphalt Top Course to a depth of not less than the depth

as shown on the Contract Drawings, unless otherwise directed by the Construction Manager.

2. Place temporary pavement markings and permanent pavement markings (all types), as shown on the Contract Drawings. Pavement markings replaced must be approved and accepted by the respective Municipality and/or Hudson County prior to payment.
3. Application of equivalent temporary markings shall be placed after temporary restoration is placed and roadways are reopened to traffic.
4. Unit of Measure: Tons, as measured in truck, provided via material manifest, unless otherwise directed by the Construction Manager. Costs of all tools, labor, equipment, materials, traffic control, protection of pavement markings against traffic and weather and any incidentals necessary for the installation of the pavement markings shown on the Contract Drawings as required shall be included in this line item for Roadway Top Course, Hot Mix Asphalt. The price shall be full compensation for all pavement markings of all sizes and colors required.

XX. Item 20: Replace Concrete Curb

1. Description: Furnish and install new concrete curb, as required by the Contract Documents or as directed by the Construction Manager.
2. Payment shall be based on the neat cubic yards of curb installed and measured in place.

YY. Item 21: Replace Concrete Sidewalk

1. Description: Furnish and install new concrete sidewalk, as required by the Contract Documents or as directed by the Construction Manager. Item shall include installation of the DGA base course, curb ramps, expansion joints, and tactile warning surfaces as part of this line item.
2. Payment shall be based on the neat cubic yards of concrete sidewalk installed and measured in place.

ZZ. Item 22: Replace Concrete Driveway

1. Description: Furnish and install new concrete driveway, as required by the Contract Documents or as directed by the Construction Manager. Item shall include installation of the 3/4-inch clean stone base course as part of this line item.
2. Payment shall be based on the actual quantity of concrete driveway installed measured in cubic yards, verified by daily as-built log of installed material, as approved by the Construction Manager.

AAA. Item 23: Replace Asphalt Bikeway/Walkway

1. Description: Furnish and install new marked bikeway as required by the Contract Documents or as directed by the Construction Manager.
2. Unit of Measure: Tons, as measured in truck, provided via material manifest, unless otherwise directed by the Construction Manager.

BBB. Item 24: Utility Relocation, If and Where Directed

1. Description: This Item covers the cost to relocate utilities that interfere or conflict with the work due to unforeseen conditions and was not expected as a part of the Contractor's work. Payment will be on a Time and Materials basis in accordance with the Contract Documents. Contractor shall coordinate all utility relocation work with the owner of that utility and/or as instructed by the Construction Manager. A bid amount of \$4,500,000.00 is obligated for this item. The overall project schedule shall not be impacted by any utility relocation covered in this item. Contractor shall not make a delay claim based on the work covered under this item.
2. This item also applies to the Contractor's investigative efforts to determine the unknown subsurface item if encountered during the course of excavation, as directed by the Construction Manager, unless work is explicitly covered under another bid item.
3. Unit of Measure: Based on Time and Materials costs submitted and approved by the Construction Manager. Contractor shall submit all proposed equipment, labor, materials, and preliminary schedule for approval by the Construction Manager prior to the beginning the work in this item. Contractor shall submit daily equipment, labor, and material quantities for verification by the Construction Manager at the end of each day of work.

CCC. Item 25: Uniformed Traffic Directors, If and Where Directed

1. Description: Coordinate with the City of Hoboken, City of Jersey City, Township of Weehawken, NJ Transit and Port Authority, the services of Uniformed Traffic Control Officers in accordance with this Section, paragraph 1.12, and as instructed by the Construction Manager.
2. Allowance to reimburse Contractor for actual costs paid is set at \$3,100,000.00. No mark up on costs is allowed.

DDD. Item 26: Misc. Concrete, If and Where Directed

1. Furnish, place, grade, and compact Concrete Pavement within the limits as directed by the Construction Manager to a depth of not less than the depth as shown on the Contract Drawings, unless otherwise directed by the Construction Manager. Bedding to be paid for under Item 17: Roadway Base Course, DGA.

2. Unit of Measure: Installed cubic yards of concrete pavement, measured in place.

EEE. Item 27: Sheeting Left in Place, If and Where Directed

1. Description: Total square feet of trench sheeting left in place as directed by the Construction Manager and as described in this Section and Paragraph 1.10.
2. Unit of Measure: Total square feet left in place as directed by the Construction Manager

FFF. Item 28: Type 57 Clean Stone, If and Where Directed

1. Description: Additional stone required to backfill over-excavations of unsuitable material to the normal backfill limits as indicated on the plans or if and where directed by the Construction Manager. Separate payment shall not be made for Type 57 Clean Stone that is paid under other Items.
2. Unit of Measure: Cubic yards of Type 57 Clean Stone, measured in-place, post compaction.

GGG. Item 29: Subsurface Utility Explorations (SUE)

1. Description: To provide a Quality Level A test pit to locate utility or other potential obstructions as detailed in paragraph 1.13 of this Section, as described in Section 023219, as indicated on the plans or if and where directed by the Construction Manager. The work includes developing work plans; obtaining relevant permits; coordination with local municipalities for work/ street opening permits and coordination with utilities; and reporting. The data will be used to determine if a pipe run needs to be adjusted in advance of the work being performed. The cost of all utility location and protection, with the exception of those covered under this Item, are to be included in the cost of work.
2. Unit of Measure: Each test hole performed with corresponding submitted report for the locations that are specifically identified on the plans for SUE.

HHH. Item 30: Microtunnel for NHSA Outfall

1. Description: Provide and install all items including but not limited to casing pipe and appurtenances, launching and receiving pits, dewatering, installation of break-in/break-out blocks, survey, excavation and backfill, pile caps, bulkheads, surface restoration and all incidentals required to construct a cased crossing of the floodwall foundation as shown on Plan Sheets C800 through C803. The micropiles for the casing pipe support are to be paid for in the micropile unit cost item.
2. Unit of Measure: Lump sum payment under this item will constitute full compensation for all work and costs to perform and complete the various types of

microtunnel improvements with the exception of allowances and unit price contract items.

III. Item 31: Urban Amenities

1. Description: Provide and install all the structures, plantings, irrigation, surface treatments, wall treatments and other specified items shown on Plan Sheets designated URBAN AMENITIES, unless specifically noted to include in other pay items. This Item will not include the Resist Wall foundations, stem wall, wall formliners, gates or other items paid for in other pay items. Any surface improvements not specifically noted in Plan Sheets designated URBAN AMENITIES are to be paid for in other pay items.
2. Unit of Measure: Lump sum payment under this item will constitute full compensation for all work and costs to perform and complete the various types of urban amenity improvements with the exception of allowances and unit price contract items.

JJJ. Item 32: Cove Park Improvement Option A (Base Park)

1. Description: Provide and install all the structures, landscaping, drainage, fill materials and placement, load transfer platforms, plantings, surface treatments, retaining walls, wall treatments and other specified items shown on Plan Sheets designated COVE PARK OPT A – BASE PARK, unless specifically noted to include in other pay items. This Item will not include the Resist Wall foundations, stem wall, formliners, gates, gate storage structures or other items paid for in other pay items.
2. Unit of Measure: Lump sum payment under this item will constitute full compensation for all work and costs to perform and complete the improvements for Cove Park Option A (Base Park) with the exception of allowances and unit price contract items.

KKK. Item 33: Controlled Low Strength Material (CLSM) – If and Where Directed

1. Description: Provide Controlled Low Strength Material (CLSM) as described in Section 033400 and at the direction of the Construction Manager. Cost to include placement and all incidentals as required by the Contract Sections.
2. Payment shall be based on the neat cubic yards placed and measured in place.

LLL. Item 34: Nighttime Work, If and When Directed

1. Description: This Item is an allowance that covers the cost to reimburse the Contractor for the additional incremental payroll costs for rescheduling work to nighttime hours, or Saturdays, Sundays and legal holidays as a result of the direction of County of Hudson, City of Hoboken, Township of Weehawken, Jersey

City, New Jersey Transit, Hudson-Bergen Light Rail, and as approved by the Construction Manager. Contractor shall coordinate all nighttime work hours with municipality and transit company as approved by the Construction Manager. Payment will be based on premium time payroll costs for field work staff only. No markups of the premium time reimbursement will be paid. An allowance of \$1,500,000.00 is set for this item.

2. Unit of Measure: Based on incremental premium time payroll costs submitted and approved by the Construction Manager. Contractor shall submit, seven (7) days in advance of the work, all proposed labor forces involved in the nighttime work and preliminary schedule for approval by the Construction Manager. Contractor shall submit daily labor quantities for verification by the Construction Manager at the end of each day of nighttime work.

MMM. Item 35: Excavation of Test Pits, If and Where Directed

1. Description: Excavation of test pits as directed by the Construction Manager. Test pits under this item shall include any test pits as directed by the Construction Manager for any reason. Material excavated during test pit activities shall be returned into the excavation upon acceptance by the Construction Manager. Excavated material shall be returned in the reverse order it was removed (i.e., most recently excavated material removed first). To prevent future settlement, Contractor shall compact material as it is returned to the excavation. Costs for disposal of pavement removed and temporary pavement restoration shall be considered incidental to this item.
2. Payment shall be based on the neat cubic yards removed, measured in the excavation.

NNN. Item 36: Excavation of Test Pits, Archeological Investigation

1. Description: Excavation of test pits as directed by the Construction Manager. Test pits under this item shall include those identified under the Field Testing Plan for the New Jersey State Historic Preservation Office. Costs shall include any shoring and/or excavation protection required to perform the work. Material excavated during test pit activities shall be returned into the excavation upon acceptance by the Construction Manager. Excavated material shall be returned in the reverse order it was removed (i.e., most recently excavated material removed first). To prevent future settlement, Contractor shall compact material as it is returned to the excavation. Costs for disposal of pavement removed and temporary pavement restoration shall be considered incidental to this item.
2. Payment shall be based on a neat cubic yard excavated for each test pit performed as approved by the Construction Manager.

OOO. Item 37: Maintenance and Protection of Traffic

1. Description: Provide, install, operate, maintain and remove of all temporary traffic control devices, signs and pavement markings as shown on the Contract Drawings and as required by the City of Hoboken, New Jersey Transit and all other public and private entities impacted by the Work. Costs for Uniformed Special Officers as defined in paragraph 1.12, will be paid for separately.
2. Payment shall be on a monthly rate for the duration of the Project or until the Contractor is directed by the Construction Manager Maintenance and Protection of Traffic is not required.

PPP. Item 38: Air, Noise, Dust, Vibration and Settlement Monitoring

1. Description: Provide, operate, maintain and report air, noise, dust, vibration and settlement monitoring as indicated in Sections 023214 and 012901.
2. Payment for air, noise, dust, vibration and settlement monitoring for the duration of the Project shall be paid lump sum amount bid.

QQQ. Item 39 A, B, C: Electrical Work

1. Description: Provide all electrical services required by the Contract and not specifically covered by other items. Price to include all materials, labor, equipment, subcontractors, permits, and all other incidentals required for a complete project meeting the Contract Documents.
2. Lump Sum payments under these Items will constitute full compensation for all work and costs to perform and complete the various types of electrical work appurtenant to the Item 39A Electrical Work - Resist Structure, Item 39B Electrical Work - Urban Amenities, and Item 39C Electrical Work - Gates with the exception of allowances and unit price contract items.

RRR. Item 40: Gravel, If and Where Directed

1. Description: Gravel required as indicated on the plans as a separate item, or if and where directed by the Construction Manager. Gravel shown on Plan Sheets C321, C326, and C327 shall be paid under this item. Separate payment shall not be made for Gravel that is included within, or paid under, other Items.
2. Unit of Measure: Cubic yards of Gravel, measured in-place, post compaction.

SSS. Item 41: Brick, Cobblestone, and Paver Sidewalks, Pavement and Driveways

1. Description: Install brick, cobblestone, and paver sidewalks, pavement, and driveways as required by the Contract Documents or as directed by the Construction Manager. Item shall include furnish and installation of new, or

removal and reinstallation of existing brick, cobblestone, and paver sidewalks, pavement, and driveways as required by the Contract Documents or as directed by the Construction Manager.

2. Payment shall be measured in square yards of brick, cobblestone, and paver sidewalks, pavement, and driveways, as measured in place.

TTT. Item 42: New Jersey Transit Force Account

1. Description: Coordinate with NJ Transit for the services of inspectors, engineers, watchmen, flagmen, and any other required personnel for oversight and execution of the work on NJ Transit property as instructed by the Construction Manager.
2. Allowance to reimburse Contractor for actual costs paid is set at \$1,500,000.00. No mark up on costs is allowed.

UUU.Add/Alt Item 1: Cove Park Improvement Option B (Full Park)

1. Description: Provide and install all the structures, landscaping, drainage, fill materials and placement, load transfer platforms, plantings, surface treatments, retaining walls, pedestrian bridge, wall treatments and other specified items shown on Plan Sheets designated COVE PARK OPT B – FULL PARK, unless specifically noted to include in other pay items. This Item will not include the Resist Wall foundations, stem wall, formliners, gates, gate storage structures or other items paid for in other pay items.
 - a. This designated COVE PARK OPT B – FULL PARK Item is for all Work required in addition to the Base Park work. As such, when determining the bid cost for the Full Park the Contractor shall not include costs for all work shown on the Plan Sheets designated COVE PARK OPT A – BASE PARK to avoid duplication of costs already included in the Base Park work.
 - b. For example, items such as site demolition, load transfer platform, and column supported embankment shall be included in the Base Park bid item because those items are to be completed as a part of the Base Park work. These items are also shown on the Full Park plan sheets. Therefore, when determining the bid cost for the Full Park the Contractor shall not include the costs for these specific items. Please note the items above are not a complete list of duplicative items and are only listed to provide examples and attempt to offer clarity.
 - c. There may be components in the Base Park that may require additional effort should the Full Park be implemented (items such as, but not limited to irrigation system, concrete pathways, railings, etc.). The Contractor shall include the incremental increase in a cost for the work in the Add/Alt bid item for the Full Park and place the original cost in the Base bid. These items shall

not be duplicated within the Add/Alt bid item work. All work that is a component of Item 32: Cove Park Improvement Option A (Base Park) that will not be performed due to the execution of Add/Alt Item 1: Cove Park Improvement Option B (Full Park) shall not be included in the lump sum price of Add/Alt Item 1: Cove Park Improvement Option B (Full Park).

2. Unit of Measure: Lump sum payment under this item will constitute full compensation for all work and costs to perform and complete the improvements for Cove Park Option B (Full Park) with the exception of allowances and unit price contract items.

END OF SECTION 012901

SECTION 013443 – ENVIRONMENTAL PROCEDURES

PART 1 - GENERAL

1.01 SECTION INCLUDES

- A. Environmental protection considerations for the Project, including:
 - 1. Submittals;
 - 2. General Requirements;
 - 3. Protection of Natural Resources;
 - 4. Temporary Erosion and Sedimentation Control;
 - 5. Toxic Substances;
 - 6. Waste Characterization;
 - 7. Off-Site Disposal;
 - 8. Control and Disposal of Waste, Trash, and Debris;
 - 9. Control and Disposal of Chemical and Sanitary Wastes;
 - 10. Decontamination Procedures;
 - 11. Dust Control; and
 - 12. Construction Noise Control.

1.02 PAYMENT

- A. No separate payment shall be made for performing any Work required under this Section unless noted otherwise. All costs for Work required by this Section shall be included in the applicable lump sum(s), unit price(s), or allowance(s) as set forth in Section 012901.
- B. Disposal of excess non-hazardous fill and disposal of hazardous fill will be paid for under the appropriate unit price item.

1.03 REFERENCES

- A. Code of Federal Regulations (CFR):

1. 40 CFR Part 761 – Identification and Listing of Hazardous Waste.
2. 40 CFR 61 Subpart M - National Emission Standards for Asbestos.
- B. New Jersey Department of Environmental Protection (NJDEP):
 1. New Jersey Flood Hazard Area Control Act rules (N.J.A.C. 7:13).
 2. Surface Water Quality Standards (NJAC 7:9B).
 3. Ground Water Quality Standards (NJAC 7:9C).
 4. New Jersey Pollutant Discharge Elimination System (NJPDES) Rules (NJAC 7:14A).
 5. NJDEP - Historic Fill Material Technical Guidance (April 2013).
- C. National Registers of Historic Places (16 U.S.C., paragraph 470a).
- D. Rebuild by Design Hudson River Project Resist Alignment – Field Testing Plan

1.04 RELATED SECTIONS

- A. General Conditions 4.7 - Shop Drawings and Other Submittals.
- B. Section 012901 – Measurement and Payment.
- C. Section 014300 – Quality Requirements.
- D. Section 015713 - Erosion Control, Sedimentation, and Containment of Construction Materials.
- E. Section 020804 - Dust and Volatile Emission Control.
- F. Section 021600 – Excess Clean Fill and Contaminated Materials Management.

1.05 SUBMITTALS

- A. The Contractor shall submit the following in accordance with General Conditions Article 4.7.
 1. Proposed protection and removal procedures for historic and scientific specimens. Provide procedures for the identification and protection of historic architectural features to be removed, safe conduct of the Work, careful removal and disposition of preserved features, and the protection and storage of preserved features. Include Contractor’s proposed schedule of removal of designated items.

2. A certificate that all materials and operating equipment installed as a part of this Contract, the installation thereof and all equipment used in the construction, are in compliance with all applicable federal, State, and local laws, ordinances, regulations, and permits concerning environmental pollution control and abatement.
3. Submit a Materials Management Plan (MMP). Contractor shall prepare a MMP to address: the management of regulated materials during construction and detail the Contractor's plans and methods for: a.) waste characterization and b.) disposal plan for excess soils, concrete, and materials. The MMP shall include a description of how the Contractor will control environmental disturbances during construction and contingency measures for controlling potential spills from construction and operational activities. The MMP shall include a description of: Stockpiling/Staging Requirements and Procedures; Spill Protection and Prevention Requirements and Procedures; Excavated Soil Management Procedures; Procedures for Handling Free Product; Backfilling and Capping; Decontamination Procedures; and Emergency Response Procedures. The MMP shall identify at least three (3) off-site licensed disposal/recycling facilities for each type of disposed material. The MMP shall include a copy of the A-901 license for the Contractor and a copy for each of the transporters. The MMP shall address means and methods for handling, treatment, and disposal of contaminated groundwater, if encountered. The MMP shall be approved by the Construction Manager's Licensed Site Remediation Professional (LSRP).

PART 2 - PRODUCTS

(Not Used)

PART 3 - EXECUTION

3.01 GENERAL REQUIREMENTS

- A. Provide and maintain environmental protection defined herein.
- B. Comply with all federal, State, and local laws, ordinances and regulations pertaining to environmental protection.
- C. Ensure compliance by subcontractors with the provisions of this and various other sections of these Contract Sections.
- D. Use of equipment from which factory-installed, anti-pollution and noise control devices are removed or rendered ineffective, either intentionally or through lack of proper maintenance is prohibited.

- E. Environmental Protection: Provide protection, operate temporary facilities, and conduct construction as required to comply with environmental regulations to minimize possible air, waterway, and subsoil contamination or pollution or other undesirable effects.
 - 1. Comply with work restrictions noted in individual Sections.

3.02 PROTECTION OF NATURAL RESOURCES

- A. General: It is intended that the natural resources within the Project boundaries and outside the limits of permanent work performed be preserved in their existing condition or be restored to an equivalent of the existing condition upon completion of the Work. Confine onsite construction activities to areas defined by the Contract Drawings and Contract Sections.
- B. Protection of Existing Waterways and Highways:
 - 1. Do not dump debris or rubbish of any kind into or allow to fall into drainage swales, waterways, onto adjacent banks, or onto highways. Take care to prevent damage and injury to personnel, vessels, and vehicles using rivers, highways, or pedestrian ways. Provide devices and maintain as required to prevent such occurrences. Promptly remove any material or items falling into a river, onto adjacent banks or onto highways and immediately report to the Construction Manager and the jurisdictional agency.
- C. Land Resources:
 - 1. Except in areas indicated to be cleared, do not remove, cut, deface, injure, or destroy trees, shrubs, and vegetation without special permission from the Construction Manager. Do not fasten or attach ropes, cables, or guys to any existing nearby trees for anchorage.
 - 2. The use of herbicides is not permitted unless otherwise specified.
 - 3. Protect existing trees and vegetation to remain and that could be injured, bruised, defaced, and otherwise damaged by construction operations. Remove rocks that are displaced into areas not cleared.
 - 4. Protect monuments, markers, and works of art prior to the start of operations.
 - 5. Repair and restoration:
 - a. All trees and other landscape features scarred or damaged by the Contractor's equipment and operations shall be repaired and restored to their original condition.

6. Construction facilities:

- a. The location of the Contractor's staging area, storage area and other construction buildings on public or privately-owned property required temporarily in the performance of the Work, require review by the Construction Manager. Store equipment and materials at the job site in conformance with applicable local statutes, ordinances, regulations, and rulings of the proper jurisdictional authority. Do not store unnecessary materials or equipment on the jobsite and take care to prevent any structure from being loaded with a weight that will endanger its structural integrity or the safety of persons. Do not store materials on or encroach upon private property without the written consent of the owners of such private property.
- b. Storage of equipment or materials will not be allowed on any public right-of-way without the expressed approval by the municipality and Construction Manager.
- c. Storage of equipment or materials will not be allowed on any easement running through private property without the expressed approval of the property owner and Construction Manager.

D. Water Resources:

1. At all times, take measures to prevent oil or other hazardous substances from entering the ground, drainage areas, and local bodies of water. Do not discharge the waste material from the washing out of concrete mixing trucks, concrete pumping, and grouting operation equipment into sewer manholes, catch basins, sewers, streets, or sidewalks.
2. Protection of Existing Wetlands and Watercourses:
 - a. Plan, schedule, and undertake work in a manner that will ensure the protection and preservation of existing wetlands and watercourses.
 - b. Undertake work in and around wetlands and water courses in a manner to prevent any impact upon health, safety, and welfare.
 - c. The Contractor is to obtain written confirmation from the Construction Manager that all work in and around any wetland or watercourse is complete and areas have been restored as required.
3. Storm Water Control: Comply with requirements of authorities having jurisdiction. Provide barriers in and around excavations and subgrade construction to prevent flooding by runoff of storm water from heavy rains.

E. Flood Plain Management:

1. Design and undertake work that may involve floodplains in full compliance with the New Jersey Flood Hazard Area Control Act rules at N.J.A.C. 7:13.

F. Staging Areas:

1. Do not use in connection with this Contract, for storage, as a staging area or as a preparation site, any cultural resource facility, building, site or cleared area that is, as of the date of this Contract, on or eligible for listing on the State or National Registers of Historic Places (16 U.S.C., paragraph 470a), without the prior approval of the Construction Manager.
2. For the purpose of the preceding paragraph, the term “cultural resource” includes districts, sites, building, structures, and objects significant in American history, architecture, archaeology, or culture.

G. Historical and Scientific Specimens:

1. Protect and preserve intact all historic architectural features indicated on the Drawings and designated by the Construction Manager. Protect these features from damage, including, but not limited to that resulting from the elements, vandalism, and effects of excavation, demolition, removal, and construction operations. Remove reserved features in a manner to prevent damage and pack or crate in a manner to protect from damage. Mark all containers with proper identification and deliver to designated onsite areas for storage or transfer to a warehouse. Replace or repair lost, or damaged designated architectural features as directed by the Construction Manager. Protect the right of ownership of the property owner with regards to all preserved items.
2. If during the course of Work, artifacts or other evidence of archaeological, historic, or scientific value are discovered or accidentally exposed, report such artifacts or evidence immediately to the Construction Manager. Halt work in the immediate area and protect the artifacts or other evidence from damage, including that resulting from the elements, vandalism, and the effects of excavation, demolition, removal, and construction operations until such time as qualified officials from the NJDEP are able to conduct appropriate investigations. Do not proceed with Work in the immediate area until authorization to proceed is obtained from the Construction Manager. Deliver any such evidence or artifacts found during construction operations or subsequent investigations required by this Section into the custody of the Construction Manager. Such evidence or artifacts do not become the property of the Contractor. Any delay in the progress of the Work as a result of encountering archaeological or historic artifacts on the project is to be mitigated by the Contractor.

H. Field Testing Plan for NJDEP Historic Preservation Office Compliance:

1. The Contractor shall excavate the following locations shown in Table 013443-1 (below) in a manner controlled by NJDEP’s professional archaeologist (Archaeologist). The Archaeologist will direct the Contractor’s excavator to excavate in a slow and controlled manner and have the ability to stop the excavator during the excavation process to record the excavation and to photo document the excavation and excavated materials. The Contractor shall provide access for the Archaeologist to hand dig within the excavation if necessary. The excavation shall measure approximately 3LF X 10LF by the depth indicated on Table 013443-1. The approximate excavation depth shall be the shallower of the depths indicated in column “Depth Below Grade (Resource)” and “Depth Below Grade (Construction)” as indicated on Table 013443-1. The Archeologist shall make all final determinations when the required excavation depth has been achieved. The excavation dimensions may be increased or decreased, as directed by the Archeologist, if required to access and evaluate cultural resources. The Contractor shall assume that it will take up to 4 hours to complete the excavation to the bottom depths at each of the locations in Table 013443-1. This time duration is based on the time starting once the existing asphalt material or other overburden is excavated and removed. Once the excavation has progressed below a depth at which archaeological remains may be anticipated, the Archaeologist will recommend that the individual work site be declared a Cleared Site and the Contractor will be able to continue with their work. The Contractor shall provide a minimum of 72 hours advance notice in writing to the Construction Manager prior to performing the work in the areas identified in Table 013443-1.
2. If the artifacts and/or features are identified and assessed by the Archaeologist to be potentially significant archaeological remains, the NJDEP and the New Jersey Historic Preservation Office (NJHPO) will be notified. No work by the Contractor will be allowed to continue within that area until it has been cleared by the Archaeologist, NJDEP, and NJHPO. The extent of the area to be protected will be defined by the Archaeologist and will include sufficient space to adequately sample the cultural deposits and stage the workspace for further archaeological investigation. Representatives of NJDEP and NJHPO will be responsible for attending all necessary field views, meetings, or phone conferences to make timely decisions, which in most cases will not exceed two business days.

Table 013443-1 - Archaeologist Excavation Locations

Test Pit No.	Sta. No.	Street	Depth Below Grade (Resource)	Depth Below Grade (Construction)	Resource
1	302.00	Near Hoboken Avenue and Hudson-Bergen Light Rail	0-14 ft	4-6 ft	Mid- to late nineteenth- to early twentieth century DLWRR Railroad and Industrial deposits; early twentieth-century Freight House and structure associated with the Standard Oil Company
2	306.00	South of Hudson Bergen Light Rail, west of Jersey Ave.	0-14 ft	4-6 ft	Mid- to late nineteenth- to early twentieth century DLWRR Railroad and Industrial deposits; early twentieth-century Freight House and structure associated with the Standard Oil Company
3	319.00	Near Grove Street and Hudson Bergen Light Rail	0-35 ft	6-8 ft	Prehistoric deposits; early to mid-twentieth-century structure associated with meat packing industry, early twentieth-century grain and straw building, early to mid- twentieth-century ice platform and icehouse, railroad related fill
4	327.50	Henderson Street	0-35 ft	6-8 ft	Prehistoric deposits; mid- to late nineteenth- to early twentieth century DLWRR & Erie Lackawanna Terminal deposits

Test Pit No.	Sta. No.	Street	Depth Below Grade (Resource)	Depth Below Grade (Construction)	Resource
5	342.00	Observer Highway between Park Avenue and Garden Street	3-35 ft	5-7 ft	Prehistoric deposits; late nineteenth-century brick sewer deposits
6	410.50	Marin Boulevard north of Hudson Bergen Light Rail	0-35 ft	10-12 ft	Prehistoric deposits; mid- to late nineteenth- to early twentieth century DLWRR & Erie Lackawanna Terminal deposits
7	402.00	Between 18 th Street and Hudson Bergen Light Rail	0-35 ft	6-8 ft	Prehistoric deposits; deposits associated with Long Slip Canal and railroad-related landfill
8	200.50	Washington Street near intersection with 13 th Street	2-17 ft	6-8 ft	Historic structures
9	202.50	Intersection of Washington Street and 14 th Street	2-17 ft	6-8 ft	Seawall; historic structures
10	Between 206.00 and 206.50	Bloomfield and between 14 th and 15 th Street	0-10 ft	8-10 ft	Historic structures associated with waterfront development

Test Pit No.	Sta. No.	Street	Depth Below Grade (Resource)	Depth Below Grade (Construction)	Resource
11	212	Intersection of 15th Street and Garden Street	0-17 ft	10-12 ft	Seawall; historic structures
12	219	South of Park Avenue	0-9 ft	8-10 ft	Prehistoric deposits
13	222	East of Park Avenue	2-12 ft	5-7 ft	Erie Freight Terminal and prehistoric deposits
14	229.5	North of Harbor Path	2-12 ft	6-8 ft	Erie Freight Terminal and prehistoric deposits
15	235.00	Between Lincoln Harbor Road and Hudson Bergen Light Rail	2-12 ft	5-7 ft	Erie Freight Terminal and prehistoric deposits
16	241.00	Between Park Avenue and Lincoln Harbor Road	2-12 ft	6-8 ft	Erie Freight Terminal and prehistoric deposits

- I. No separate payment shall be made for the work identified under Field Testing Plan for NJDEP Historic Preservation Office Compliance. Payment should be included in the various unit bid prices for excavation.

3.03 TEMPORARY EROSION AND SEDIMENTATION CONTROL

- A. Temporary Erosion and Sedimentation Control: Comply with requirements of the Soil Erosion and Sediment Control Plan (SESC Plan) as approved by the Hudson-Essex-

Passaic (HEP) Soil Conservation District and the associated New Jersey Pollutant Discharge Elimination System (NJPDES) Stormwater General Permit for Construction Activities (5G3 Permit). Upon receipt of the final SESC Plan approval from HEP SCD, Contractor shall apply to NJDEP for Request for Authorization under the 5G3 Permit.

- B. Temporary Erosion and Sedimentation Control: Provide measures to prevent soil erosion and discharge of soil-bearing water runoff and airborne dust to undisturbed areas and to adjacent properties and walkways, according to Section 015713 and requirements of the approved SESC Plan or authorities having jurisdiction, whichever is more stringent.
1. Verify that flows of water redirected from construction areas or generated by construction activity do not enter or cross tree- or plant- protection zones.
 2. Inspect, repair, and maintain erosion- and sedimentation-control measures during construction until permanent vegetation has been established.
 3. Clean, repair, and restore adjoining properties and roads affected by erosion and sedimentation from the project site during the course of the Work.
 4. Remove erosion and sedimentation controls and restore and stabilize areas disturbed during removal.

3.04 TOXIC SUBSTANCES

- A. Contractor is responsible for collecting representative samples of soil and submitting the samples to a New Jersey State certified laboratory for analysis for off-site disposal purposes as described herein, in accordance with the MDP. Contractor will have three options for excavated materials:
1. Replace excavated material in the trench as backfill at the location where it was excavated, in accordance with NJDEP Linear Construction Guidelines. Material reused in this manner cannot contain any free or residual product.
 2. Pre-sample the soils along the alignment for waste classification and disposal using test pits, vacuum truck or other soil extraction means approved by the Construction Manager.
 3. If excess material is not immediately removed from the site to the designated disposal facility, stockpile excess excavated material at a suitable site controlled by the Contractor for sampling, waste classification, and disposal.
- B. Asbestos and Hazardous Materials Procedure: In the event the Contractor, during the course of the Work, encounters the presence of asbestos or any materials containing asbestos, or PCBs or any other hazardous materials not previously identified, promptly

notify the Construction Manager. Do not perform any work pertinent to the asbestos or hazardous material prior to receipt of special instructions from the Construction Manager. Any delay in the progress of the Work as a result of encountering either asbestos or hazardous materials on the project will be mitigated by the Contractor. Within 24 hours of this notification to the Construction Manager of the encountering of the presence of asbestos or hazardous materials, the Contractor will meet with the Construction Manager to re-plan and work around the affected area.

- C. Comply with all applicable provisions of the National Emission Standards for Asbestos (40 CFR 61 Subpart M).
- D. Comply with the local regulations of PCBs. Since these chemicals are used in some existing insulation, existing fixed and vehicular transformers, assure proper marking, handling, and disposal of any PCBs in accordance with the regulations of 40 CFR 761.
 - 1. Do not use PCB chemical substance, mixture, equipment, container, sealant, coating, or dust-control agent except in accordance with regulations of 40 CFR 761.
 - 2. Immediately report in writing any PCB chemical substance, mixture, equipment, container, sealant, coating or dust control agent, found stored within the Work Site to the Construction Manager and stop work in the area.
- E. Soil containing free and/or residual product must be disposed at an off-site licensed disposal/recycling facility. The Contractor shall provide means and methods for disposal of free product in the case it is encountered.

3.05 WASTE CHARACTERIZATION

- A. Waste Characterization
 - 1. Regulated material consists of material of whatever nature encountered that is classified as regulated or hazardous in the NJDEP Solid Waste Regulations, N.J.A.C 7:26-1 et seq. or N.J.A.C 7:26-8.
 - 2. Submit the results of material sampling and analysis, material sampling and analysis plans, waste facilities and waste transporters certification to accept waste, waste facility applications and acceptance documentation, and fee payment requirements to the Construction Manager at least fifteen (15) days before planned removal of regulated material.
 - 3. For off-site disposal purposes, the Contractor is responsible for collecting representative samples of the excess soil and submitting the samples to a New Jersey State certified laboratory for analysis. The Contractor will sample and analyze material in strict accordance with the most recent versions of the NJDEP

Field Sampling Procedures Manual. The disposal facility will dictate the waste characterization analytical parameters and sampling frequency.

4. The Contractor shall determine the process for waste characterization. If the Contractor decides to sample soil in areas designated for removal prior to excavation, the Contractor shall provide a sampling and analysis plan for in-situ waste characterization that meets the licensed disposal/recycling facility requirements. If the Contractor decides to stockpile the soil prior to disposal, the Contractor shall provide a sampling and analysis plan for stockpiled soil waste characterization that meets the licensed disposal/recycling facility requirements. The selection between in-situ and stockpile waste characterization may be dictated by the ability to stockpile the soil within the Project area pending disposal.
5. The results of the waste characterization analysis will determine whether the soil is hazardous or non-hazardous (i.e., ID-27) waste.

3.06 OFF-SITE DISPOSAL

A. Off-Site Disposal and Transportation

1. Prior to disposal activities, the Contractor will ensure that all operations associated with disposal/recycling of materials are in compliance with applicable federal and New Jersey Department of Transportation regulations, as well as all applicable local requirements. The Contractor shall hold an A-901 license for the collection or disposal of solid or hazardous waste and a Certificate of Public Convenience and Necessity (CPCN) for solid waste, pursuant to NJSA 13:1E-126 et. seq. and NJSA 48:13A-1 et. seq. Transporters of solid or hazardous waste shall also have an A-901 license and CPCN. The Construction Manager's LSRP will review the Contractor's proposed methods and facilities.
2. The Contractor will specify the proposed transportation/storage/disposal (TSD) facility. A commitment letter will be obtained from the TSD facility indicating the capacity to accept the type and volume of waste material and stating that it will be open for business during the Contract duration to accept the volume of waste materials. The Contractor will ensure that the hauler of record and TSD facility possess the proper licenses, credentials, and experience to transport and dispose of the subject material.
3. The Contractor will provide the Construction Manager with a list of permitted alternative TSD facilities to be utilized in the event the approved facility ceases to accept waste materials generated under this contract. The DEP will not bear any additional costs if the alternative TSD facility is used for waste disposal.

4. The Contractor will maintain a Daily Soil & Groundwater Tracking Log to record soil and groundwater movement on site. The Daily Soil & Groundwater Tracking Log will be used to record all incoming and outgoing material for the duration of disposal activities. The log will include up-to-date records that identify the origin/source of each waste stream in the staging area; type, characteristics, and quantity of material; list the specific storage location; indicate the date the materials were transported from the storage area to the final destination; and the location of the final destination.
5. The Contractor shall comply with all applicable regulations, including, but not limited to:
 - a. Vehicle placard requirements.
 - b. Container requirements.
 - c. Manifest requirements.
 - d. Responsibilities and requirements for collectors and haulers of hazardous and non-hazardous solid waste.
 - e. Posted weight limitations on roads and bridges.
 - f. Other local restrictions on storage and transportation of waste/debris.
6. Any material deemed hazardous shall be removed from the site within 90 days as per NJDEP regulations (NJAC 7:26). No hazardous material shall be reused.
7. Excess regulated non-hazardous soil must be disposed off-site within 180 days of excavation as per NJDEP regulations (NJAC 7:26). The licensed hauler shall transport the regulated soil directly to the selected disposal facility.
8. Containers of waste will be immediately sealed as each container is filled. The Contractor shall continuously maintain custody of all non-hazardous and hazardous material generated at the Work site including security, short term storage, transportation, and disposition until custody is transferred to the off-site TSD facility. All vehicles used to transport material to off-site facilities shall be covered to prevent loss soil during transport.
9. Immediately submit written notification to the Construction Manager if problems arise regarding the facility chosen to accept the regulated material for off-site management that would require the return of waste or if the chosen facility has violated any environmental regulation that may result in regulatory enforcement action. Propose an alternate disposal facility and obtain the Construction Manager's written approval of off-site management at such facility.

10. Should the disposal facility reject material transported from the site, and said material is returned to the Project Site, the material shall be separately stockpiled in an area that does not “cross contaminate” other materials, compromise construction activities, or violate existing permits and approvals. The Contractor, in consultation with the DEP, shall assess said stockpiled material for disposal options.
11. Potentially contaminated soil designated for additional testing will be stockpiled in accordance with the Material Management Plan under Section 021600. The types and frequencies of tests to be conducted will be based on knowledge of the material, previous pre-characterization and waste characterization data, conditions encountered during excavation, and the permit requirements of the receiving recycling or disposal facility.
12. The licensed hauler shall transport the regulated material to the disposal/recycling facility with no unauthorized stops in between, except as required by regulatory authority. The hauler shall use appropriate vehicles and operating practices to prevent spillage or leakage from occurring during transport. Remove excess soil adhering to the wheels or under carriage of the vehicles before leaving the Project Limits. If soil or water escapes to the public roads, immediately clean the road to restore it to the original condition and immediately notify the Construction Manager. Do not transport contaminated material over public roads if they contain free liquid or are sufficiently wet to be potentially flowable during transport.
13. Once the material leaves the project limits, the Contractor is responsible for ensuring that the handling procedures, placement methods, and disposal location are according to applicable Federal, State, and local laws, rules, and requirements, including permits that may be issued for the project. If the disposal of contaminated material results in violation notices from any governmental authority, immediately correct the violation. Indemnify and defend the DEP for any violation incurred, penalty assessed, or any claims, suits, losses, demands or damages of whatever kind or nature arising out of, or claimed to arise out of, the improper disposal of excess materials. If the Contractor does not correct the violation to the satisfaction of the governmental authority that issued the violation notice, the Contractor is responsible for assessed penalties including costs incurred by the DEP to remedy the violations.

B. Waste Disposal Documentation

1. Comply with the requirements specified in Section 014300.

2. Submit to the Construction Manager a bill of lading for each truckload of regulated material removed from the Project Limits. Ensure that the bill of lading and waste manifest include the following information:
 - a. Transport subcontractor name, address, permit number, and telephone number.
 - b. Type and quantity of material removed.
 - c. Weight of vehicle with weigh slip.
 - d. Recycling or disposal facility name, address, permit number, and telephone number.
 - e. Date removed from the Project Limits.
 - f. Signature of transport vehicle operator.
3. The Construction Manager will sign the bills of lading for the DEP as the generator of the waste. Submit one (1) copy of the bill of lading to the Construction Manager by the end of each working day that the transport vehicle leaves the site. For hazardous regulated material, the manifest will verify the type and quantity of hazardous regulated material being transported off-site.
4. The Uniform Hazardous Waste Manifests are required by the Federal Resource Conservation and Recovery Act (RCRA) (40 CFR Subpart B Parts 262.20 to 262.23) and N.J.A.C 7:26G for all off-site shipments of hazardous regulated materials.
 - a. The DEP is the generator of the waste. The DEP will obtain an EPA Identification Number (EPA ID#) and supply this information to the Construction Manager for inclusion on the Uniform Hazardous Waste Manifest. The Construction Manager will provide the Contractor with an EPA ID# if the Project contains hazardous regulated material.
 - b. Complete the manifest form in accordance with all applicable regulations and mail to the Bureau of Environmental Program Resources at 951 Parkway Avenue, PO Box 600, Trenton, NJ 08625-0600 to ensure that the “final disposition” (TSD to Generator) copy of the manifest is mailed back to the office responsible for the record keeping requirements.
 - c. The Construction Manager will keep a copy of the original manifest for the Contract files.

- d. The Contractor is responsible for all manifest discrepancies. Immediately report discrepancies to the Construction Manager and resolve to the satisfaction of the Construction Manager.
5. Copies of each manifest/bill of lading shall be submitted to the Construction Manager within seven (7) business days following transportation from the site, and within five (5) business days after delivery to the disposal facility. All manifests/bills of lading must be fully executed by the disposal facility for this task to be considered complete.

3.07 CONTROL AND DISPOSAL OF WASTE, TRASH, AND DEBRIS

- A. Dispose of rubbish and debris in accordance with all local ordinances.
- B. Waste Materials: No waste (including excavated asphalt, rock or other materials) or erosion materials shall be allowed to enter natural or manmade water courses. Erosion materials from excavations and borrow areas shall be contained within the affected work area. The Contractor shall develop methods for controlling waste and erosion. If waste materials come into contact with regulated materials, they shall be considered regulated materials and be managed and disposed of as such.
- C. Burning: No burning of waste will be allowed.

3.08 CONTAMINATED GROUNDWATER DISPOSAL PROCEDURES

- A. The Contractor shall select the groundwater disposal method based on anticipated dewatering rates, treatment options, proximity of storm sewers and surface water bodies, the permeability of the subsurface materials, and groundwater quality as determined by an engineer engaged by the Contractor.
- B. The potential options for managing and disposing the generated groundwater are:
 1. Discharge to surface water;
 2. Discharge to groundwater;
 3. Discharge to a sanitary sewer; and
 4. Transportation to a permitted treatment facility.
- C. Discharge to surface water will require a New Jersey Pollutant Discharge Elimination System (NJPDES) Discharge to Surface Water (DSW) Permit issued by the NJDEP Division of Water Quality. The NJDEP provides a General Groundwater Remediation Cleanup (BGR) permit for non-petroleum contamination, which authorizes discharges of treated groundwater to surface waters.

- D. NJPDES Discharge to Ground Water (DGW) Permits can also be issued by the NJDEP Site Remediation Program.
- E. Discharge to a sanitary sewer will require a permit from the receiving utility. The Contractor may be required to obtain a Treatment Works Approval (TWA) prior to discharge to public utility as well depending on groundwater characteristics. Groundwater should be considered contaminated until confirmed via sampling.
- F. If the dewatering effluent requires treatment prior to discharge to surface water or discharge to groundwater, it is likely that a Treatment Works Approval will be required from the NJDEP Division of Water Quality prior to application for the discharge permit.
- G. The Contractor shall apply for and obtain a Construction Dewatering General Permit (B7) from the NJDEP Division of Water Quality for the authorization of a short-term groundwater discharge for lowering the groundwater table during construction related dewatering of uncontaminated groundwater. Discharges associated with industrial processes, site remediation activities, and sanitary sewerage systems are not covered under the General Permit B7.
- H. The Contractor shall also apply for and obtain a Dewatering Permit-by-Rule or Water Allocation Permit from the NJDEP's Division of Water Supply and Geoscience, as needed, when the pumping or lowering of any groundwater at an average rate of 100,000 gallons per day, over a 30-day period.
- I. Permitting information can be found on the following NJDEP permitting webpages:
 - 1. NJDEP BGR DSW Permitting: http://www.nj.gov/dep/dwq/gp_bgr.htm
 - 2. NJDEP DGW Permitting: http://www.nj.gov/dep/dwq/dgw_home.htm
 - 3. NJDEP Treatment Works Approval: <http://www.nj.gov/dep/dwq/twa.htm>
 - 4. NJDEP Dewatering Permitting: http://www.nj.gov/dep/watersupply/a_wtable.html
 - 5. NJDEP Air Permitting: <https://www.nj.gov/dep/aqm/rules27.html>
- J. At all times, the Contractor shall maintain and operate proper and adequate dewatering in order to keep the construction site dry and in such condition that construction of structures and placement and compaction of fill and backfill may proceed unhindered by saturation of the area. The Contractor shall provide and maintain pumps, well points, sumps, suction and discharge lines, or other dewatering system components necessary to convey all water away from excavations. The Contractor shall prevent surface water from flooding or spilling into excavations.

- K. The Contractor shall obtain any local and State permits required for construction dewatering as discussed above. Cost of permits shall be paid by the Contractor. The Contractor shall adhere to all terms of the environmental permits.
- L. All discharges from dewatering activities to surface waters, groundwater or storm sewers shall be free of sediments. The Contractor shall meet all State and local requirements for treatment and monitoring for dewatering. The Contractor shall collect effluent samples from the treatment system at the frequency required by the permit and analyze the samples for the parameters specified in the permit. The Contractor shall provide the sample results to the Construction Manager to document that the discharge meets the permit limits.
- M. Sediment collected from the dewatering process shall be considered as a regulated material and disposed of as detailed herein.

3.09 CONTROL AND DISPOSAL OF CHEMICAL AND SANITARY WASTES

- A. Dispose of sewage through connection to municipal sanitary sewage systems. Where such systems are not available, use chemical toilets or comparably effective units with wastes periodically emptied. Include provisions for pest control and for masking or elimination of odors.
 - 1. Maintaining Sewers and Drains: The Contractor shall provide for and maintain the flow in all sewers, drains, house or inlet connections, and all water courses that may be encountered during progress of the work, at the Contractor's cost. Unless otherwise directed, the Contractor shall not allow the contents of any sewer, drain, house, or inlet connection to flow into trenches. The Contractor shall immediately remove from the proximity of the work all offensive matter, using such means as may be required at the Contractor's cost.
- B. Store chemical waste in corrosion-resistant containers, remove from the Project site, and dispose of as necessary, but not less frequently than monthly. Provide for disposal of chemical waste in accordance with standard established practices as approved by the Construction Manager. Conduct fueling and lubricating of equipment and motor vehicles onsite in a manner that affords the maximum protection against spills and evaporation. Dispose of lubricants to be discarded, in accordance with approved procedures meeting state, and local regulations. The Contractor must provide spill control kits at each work location. For oil and hazardous material spills that may be large enough to violate state, and local regulations, notify the Construction Manager immediately. The Contractor will be responsible for notifying the NJDEP Hotline and for tracking spill information.

3.10 DECONTAMINATION PROCEDURES

- A. The Contractor will designate an area for implementing decontamination procedures (e.g., steam cleaning, manual scrubbing, etc.) for all vehicles contacting contaminated material leaving the site in accordance with Section 025100. The Contractor will remove soil from the truck tires as needed to ensure that contamination is not tracked off site. Recovered wastes resulting from decontamination shall be properly characterized, transported and disposed off-site in accordance with applicable Federal, State, and local requirements and the requirements herein.

3.11 DUST CONTROL

- A. Refer to Section 020804.

3.12 CONSTRUCTION NOISE CONTROL

- A. Noise Control: The Contractor shall take every action possible to minimize the noise caused by its operation. Conduct all operations in compliance with the latest requirements of the local noise control code for maximum noise levels due to construction work. Noise-producing work shall be performed in less sensitive hours of the day or week as directed by the Construction Manager or local ordinance.

END OF SECTION 013443

SECTION 013543 – ENVIRONMENTAL ENGINEERING CONTROLS

PART 1 - GENERAL

1.01 DESCRIPTION

- A. This Section includes specifications and requirements for the disturbance and restoration of environmental engineering controls previously installed to protect human health and the environment from soils impacted with contaminants above New Jersey Department of Environmental Protection (NJDEP) Soil Remediation Standards (N.J.A.C. 7:26D) and historic fill. This also includes any previously unknown contamination that is returned to the excavation as backfill.
- B. The Contractor Scope of Work is subject to oversight by the Construction Manager's Licensed Site Remediation Professional (LSRP) In addition to NJDEP Linear Construction Project requirements, some Recognized Environmental Condition (REC) locations have existing Remedial Action Permits (RAP), Deed Notices and engineering controls, which will require separate notification, coordination and approval with the LSRP of Record for the REC locations (REC's LSRP) prior to disturbance.
- C. The Construction Manager's LSRP will review and confirm that the alterations, improvements, and disturbances to engineering controls are conducted in accordance with requirements in the Administrative Requirements for the Remediation of Contaminated Sites (N.J.A.C. 7:26C) and any existing RAP requirements in place for the REC location. Contractor is responsible for coordinating alterations, improvements, disturbances and restoration to engineering controls with each REC's LSRP of Record in advance of any disturbance. Any alterations to existing controls will require DEP notification, Deed Notice Termination, New Deed Notice, and a new RAP; Contractor shall be responsible for coordinating with the proper regulators and agencies.

1.02 PAYMENT

- A. No separate payment shall be made for performing any Work required under this Section. All costs for Work required by this Section shall be included in the applicable lump sum(s), unit price(s), or allowance(s) as set forth in Section 012901.

1.03 REFERENCES

- A. Code of Federal Regulations (CFR)
 - 1. 40 CFR Part 261 - Identification and Listing of Hazardous Waste.
 - 2. 29 CFR 1910.120 – Hazardous Waste Operations and Emergency Response.

- B. New Jersey Department of Environmental Protection (NJDEP)
 - 1. Administrative Requirements for the Remediation of Contaminated Sites (NJAC 7:26C).
 - 2. Remediation Standards (N.J.A.C. 7:26D).
 - 3. Technical Requirements for Site Remediation (N.J.A.C. 7:26E).
 - 4. Well Construction and Maintenance, Sealing of Abandoned Wells (N.J.A.C. 7:9D).
 - 5. Linear Construction Technical Guidance (January 2012).
 - 6. Fill Material Guidance for SRP Sites (April 2015).
 - 7. Guidance Document for the Remediation of Contaminated Soils (January 1998).
 - 8. Technical Guidance on the Capping of Site Undergoing Remediation (July 2014).
 - 9. Historic Fill Material Technical Guidance (April 2013).
 - 10. Presumptive and Alternative Remedy Technical Guidance (February 2018).
 - 11. Remedial Action Permits for Soils Guidance (February 2010).
 - 12. Guidance for Characterization of Concrete and Clean Material Certification for Recycling (January 2010).
 - 13. Field Sampling Procedures Manual (August 2005, as updated).
- C. Contract Provided Documents.
 - 1. Rebuild by Design Hudson River Project *Environmental Results Report* (October 22, 2019).

1.04 RELATED SECTIONS

- A. General Conditions Article 4.7 - Shop Drawings and Other Submissions
- B. Section 013443 – Environmental Procedures.
- C. Section 020804 – Dust and Volatile Emission Control.
- D. Section 021600 – Excess Clean Fill, Contaminated Soil, and Groundwater Management and Disposal.

1.05 QUALITY ASSURANCE

- A. In accordance with the NJDEP Linear Construction Technical Guidance, the LSRP hired by the Construction Manager (Construction Manager's LSRP) will serve at the LSRP of Record for the Linear Construction Project and will be responsible for compliance with the Linear Construction requirements in Subchapter 16 of the Administrative Requirements for the Remediation of Contaminated Sites, N.J.A.C. 7:26C-16.1 et. seq.
- B. The Contractor shall conduct environmental work in accordance with NJDEP Technical Guidance and local, State, and Federal requirements, in conjunction with the requirements of these Specifications. The Contractor shall notify the Construction Manager no less than 24 hours in advance if the environmental requirements of this work cannot be met.
- C. Work conducted by the Contractor that is not in accordance with this Section and Section 013443 shall be rejected by the Construction Manager.
- D. The Contractor shall conduct the work in accordance with the Material Management Plan (MMP) and Air Monitoring Plan (AMP) in conjunction with this Section and Sections 020804 and 021600.

1.06 SUBMITTALS

- A. Submit the following in accordance with General Conditions Article 4.7.
- B. Analytical data (collected within one (1) year prior to placement) and a clean fill certification letter (if acceptable to the Construction Manager's LSRP and REC's LSRP) for imported clean fill that is proposed to be used for construction purposes. A clean fill certification letter and analytical data is required from each supplier providing the clean fill. Provide analytical data and clean fill certification letters with each Material Certification that is submitted for geotechnical/construction purposes.
- C. Receipts and/or weight tickets for imported clean fill that will be used for construction purposes, including thermal fill, asphalt, concrete, and imported clean stone, and imported clean fill.
- D. The Contractor must retain a clearly labeled 5-gallon bucket of each clean fill material used at each REC location until released by the Construction Manager's LSRP or up to a maximum period of 60 days after installation of the material. The bucket must be a new, clean, 5-gallon plastic or metal bucket with a tight-fitting lid.
- E. Shop drawings showing details of engineering controls utilized by the Contractor to restore engineering controls at each REC, as approved by the REC's LSRP.

- F. Figures and surveyed coordinates identifying the locations disturbance to the engineering controls.
- G. As-built drawing showing the surveyed locations of the completed engineering control restoration. The thickness and type of each engineering control shall be denoted on the drawing.
- H. Copies of reports, correspondence and communications provided to the REC’s LSRP, in a form acceptable to the REC’s LSRP and the Construction Manager.
- I. Copies of reports and correspondence provided to the NJDEP Bureau of Operation, Maintenance, and Monitoring Deed Notice Inspection.

1.07 DEFINITIONS

- A. “Construction Manager’s LSRP” means the Licensed Site Remediation Professional (LSRP) retained by the Construction Manager to comply with the Linear Construction Project requirements in Subchapter 16 of the Administrative Requirements for Site Remediation, N.J.A.C. 7:26C-16.1 et. seq.
- B. “Recognized Environmental Condition” shall be as defined in the Rebuild by Design Hudson River Project Environmental Results Report (October 22, 2019).
- C. “REC’s LSRP” means the Licensed Site Remediation Professional retained by the Person Responsible for Conducting the Remediation for the REC location.

PART 2 - PRODUCTS

2.01 EQUIPMENT

- A. Equipment shall be free of contamination or decontaminated to comply with Section 021600 prior to contacting materials used for engineering controls to prevent cross contamination.
- B. Equipment shall comply and be operated in accordance with applicable OSHA, federal, state and local regulations.

2.02 MATERIALS

- A. Import clean materials for engineering controls, restoration, or backfill. Alternative Fill, as defined by NJDEP Fill Material Guidance for SRP Sites (2015), will not be considered.
- B. Additional materials as identified.

PART 3 - EXECUTION

3.01 ALTERATIONS, IMPROVEMENTS, AND DISTURBANCES TO EXISTING ENGINEERING CONTROLS

- A. No person shall make, or allow to be made, any alteration, improvement, or disturbance in, to, or about the Property which disturbs any engineering control at the Property without first obtaining the express written consent of the LSRP for the REC site. Nothing herein shall constitute a waiver of the obligation of any person to comply with applicable laws and regulations including, without limitation, the applicable rules of the Occupational Safety and Health Administration.
- B. The Contractor shall certify any soils proposed for backfilling excavations, and that engineering controls are returned to pre-construction/disturbance conditions or equivalent engineering control and provide the certification in writing to the Construction Manager's LSRP. Approval by the REC's LSRP and the Construction Manager's LSRP is required prior to the placement of certified clean fill materials.
- C. The Contractor shall be responsible for restoring the Work area to match pre-existing conditions or an equivalent engineering control as directed by the REC's LSRP within 60-days of initiation of the disturbance. Approval by the REC's LSRP and the Construction Manager's LSRP is required for placement of certified clean fill materials.
- D. Work conducted in wetlands shall be restored back to original conditions as per Land Use Regulation Program (LURP), United States Coast Guard (USCG), and United States Army Corps of Engineers (USACE) permits. The site shall be cleared of any debris, equipment, garbage, etc. as part of the site restoration activities. It will be the Contractor's responsibility to protect existing monitoring wells at the site including any repair or replacement due to any damages during field activities. Any permanent closure of existing monitoring wells will require prior approval of the REC's LSRP and well decommissioning by a New Jersey licensed driller to comply with Well Construction and Maintenance, Sealing of Abandoned Wells, N.J.A.C. 7:9D.
- E. Pursuant to the Administrative Requirements for the Remediation of Contaminated Sites (NJAC 7:26C, last amended August 6, 2018), a formal soil remedial action permit modification is not required for a minor disruption of an engineering control if the site is returned to its original condition within 60 days. For any disturbance lasting more than 60 days, or permanent alteration or improvement. The Contractor must provide all documentation to the Construction Manager's LSRP and the REC's LSRP for approval. The REC's LSRP shall then submit the following within 30 days plus the time it takes to receive the approved documents after the occurrence of the permanent alteration, improvement, or disturbance:

1. A Remedial Action Work plan or Linear Construction Project notification and Final Report Form, whichever is applicable.
2. A Remedial Action Report and Termination of Deed Notice Form.
3. A revised recorded Deed Notice with revised Exhibits, and
4. A Remedial Action Permit Modification or Remedial Action Permit Termination form and Remedial Action Report.

In order to meet the regulatory requirements, the contractor shall provide as-built drawings to the Construction Manager's LSRP within 15 days of the alterations.

- F. No responsible party, lessor, lessee or operator shall be required to obtain a Remedial Action Permit Modification for any temporary alteration, improvement, or disturbance, provided that the site is restored to the condition described in the REC's Deed Notice, and the responsible party, lessee, or operator complies with the following:
1. Restores any disturbance of an engineering control to pre-disturbance conditions within sixty (60) calendar days after the initiation of the alteration, improvement or disturbance.
 2. Ensures that applicable worker health and safety laws and regulations are followed during the alteration, improvement, or disturbance, and during the restoration.
 3. Ensures that human exposure to contamination in excess of the Remediation Standards, N.J.A.C. 7:26D, does not occur; and
 4. Describes, in the next biennial certification the nature of the temporary alteration, improvement, or disturbance, the dates and duration of the temporary alteration, improvement, or disturbance, the name of key individuals and their affiliations conducting the temporary alteration, improvement, or disturbance, the notice the owner gave to those persons prior to the disturbance.
 5. In order to meet the regulatory requirements, the Contractor shall provide as-built drawings of the engineering control restoration to the Construction Manager's LSRP for submittal to the REC's LSRP within 60 days of the initiation of the alternation, improvement, or disturbance or two weeks after completion of the restoration, whichever is sooner.

3.02 INSTALLATION OF ENGINEERING CONTROLS

- A. Restore any disturbance of an engineering control to pre-disturbance conditions within 60 calendar days after the initiation of the alteration, improvement or disturbance.

- B. Restoration plans for all engineering controls must be approved by the REC's LSRP prior to implementation. Final restoration of the engineering controls must be approved by the REC's LSRP.
- C. Any soils with contaminant concentrations above the most stringent NJDEP soil Remediation Standards, N.J.A.C. 7:26D, that are left in-place by the Contractor shall use the following caps for engineering controls to protect human health and the environment or equivalent engineering control:
 - 1. Clean fill (6" thick minimum), as determined by the NJDEP Fill Material Guidance for SRP Sites;
 - 2. Asphalt and Concrete (6" thick minimum), including imported clean sub-base materials; and
 - 3. Retaining walls.
- D. If clean fill is utilized as a cap for the engineering and the fill contains fines that are susceptible to erosion than the surface of the fill shall be stabilized in accordance with soil erosion and sediment control measures.
- E. If clean fill is utilized as a cap for the engineering control the Contractor shall install a visible warning layer (demarcation) at the bottom of the cap/top of impacted soil covering the entire footprint of the cap. The visible warning layer (demarcation) may include one of the following:
 - 1. High visibility vinyl construction fence; or
 - 2. Geotextile fabric.

No plastic poly shall be utilized for the warning layer (demarcation).

END OF SECTION 013543

NO TEXT ON THIS PAGE

SECTION 014150 - HEALTH AND SAFETY REQUIREMENTS

PART 1 - GENERAL

1.01 DESCRIPTION

- A. This Section includes requirements for health and safety during performance of work, including identification of applicable regulations, submittals, notification requirements, and health and safety execution specifications.

1.02 PAYMENT

- A. No separate payment shall be made for performing any Work required under this Section. All costs for Work required by this Section shall be included in the applicable lump sum(s), unit price(s), or allowance(s) as set forth in Section 012901.

1.03 REFERENCES

- A. Applicable regulations and publications include, but are not limited to, the following:
 1. Occupational Safety and Health Administration (OSHA), Title 29 CFR Part 1910, Occupational Safety and Health Standards, and Title 29 CFR Part 1926, Safety and Health Regulations for Construction Sites.
 2. National Fire Protection Association (NFPA), Flammable and Combustible Liquids Code, NFPA 30, most recent revision.
 3. United States Environmental Protection Agency (USEPA), Standard Operating Safety Guidelines, November 1984.
 4. Department of Health and Human Services (DHHS), "Manual of Analytical Methods", 3rd edition Volumes I and II, DHHS (National Institute for Occupational Safety and Health [NIOSH]) Publication 84-100.
 5. American Nation Standards Institute (ANSI), Practices for Respiratory Protection, Z88.2, most recent version.
 6. ANSI, Emergency Eyewash and Shower Equipment, Z358.1, 1981.
 7. ANSI, Protective Footwear, Z41.1, 1983.
 8. ANSI, Respirator Use Physical Qualification for Personnel, Z88.6, 1984.
 9. ANSI, Practice for Occupational and Educational Eye and Face Protection, Z87.1, 1979.

10. NIOSH/OSHA/ United States Coast Guard (USCG)/USEPA, Occupational Safety and Health Guidance Manual for Hazardous Waste Site Activities, DHHS/ Public Health Service (PHS)/ Centers for Disease Control (CDC)/NIOSH, October 1985.
 11. NIOSH Pocket Guide to Chemical Hazards, DHHS/PHS/CDC/NIOSH, June 2000 or most recent.
 12. USEPA, Health and Safety Requirements for Personnel Engaged in Field Activities, USEPA Order No. 14402.
 13. Department of Transportation (DOT) Standards and Regulations, 49 CFR 171 and 49 CFR 172.
 14. American Conference of Governmental Industrial Hygienists (ACGIH), Threshold Limit Values and Biological Exposure Indices (most recent version).
 15. Compendium of Methods for the Determination of Toxic Organic Compounds in Ambient Air, Environmental Protection Agency (EPA)/600/4-87-006, September 1986.
- B. Where two or more regulations/documents conflict, the one(s) offering the greatest degree of protection shall apply.

1.04 RELATED SECTIONS

- A. General Conditions Article 4.7 – Shop Drawings and Other Submittals.
- B. Section 012901 – Measurement and Payment.
- C. Section 014150 - Health and Safety Requirements.
- D. Section 025100 – Decontamination.

1.05 CONTRACTOR’S RESPONSIBILITY FOR HEALTH AND SAFETY

- A. The Contractor shall comply with any and all state, federal, and local ordinances and Regulations.
- B. The Contractor shall be responsible for the Health and Safety of Contractor’s employees, its Subcontractors, suppliers, agents, inspectors, visitors, the general public, and any others associated with or interacting with Contractor who provides labor, goods, or other services on the Site.
- C. The Contractor shall be responsible for emergency response planning and notification, and for actual response to any and all emergencies that may occur during the course of

- the Work, including emergencies that may occur when the Contractor is not present at the Site.
- D. The Contractor is responsible for communicating daily with the Construction Manager regarding Health and Safety issues for the Construction Manager's safe conduct of the Construction Manager's duties, but such communication shall not imply any duty or responsibility on the part of the Construction Manager with regard to Health and Safety of Contractor's employees, its Subcontractors, suppliers, the general public, or Others. The Construction Manager's responsibility and duty with regards to Health and Safety shall be limited to the Construction Manager's employees. Contractor shall have responsibility and duty to the Construction Manager to communicate Health and Safety issues accurately and in a timely manner to allow the Construction Manager to take appropriate actions to protect the Construction Manager's employees and the DEP's employees.
 - E. The Contractor shall designate a dedicated Contractor's Site Safety and Health Officer (SSHO) on the Site during the Work who shall, at a minimum, have at least one (1) year of experience as an SSHO on an uncontrolled hazardous waste site, and have 40-hour OSHA Hazardous Waste Operations training and 8-hour OSHA Supervisor training. Contractor's SSHO shall be solely dedicated to Health and Safety issues from the start of the site activities through completion.
 - F. The SSHO shall enforce the requirements of safety for all Contractor personnel on site at all times. The SSHO shall ensure that all Contractor personnel, Subcontractor personnel, and Contractor visitors, follow the Health and Safety Plan (HASP), including wearing the designated level of personal protective equipment (PPE). If the SSHO elects to require a higher level of protection than that specified in the HASP, the extra costs associated with such higher level shall be borne by Contractor, unless such extra costs are approved in advance in writing by the Construction Manager.
 - G. Prior to mobilization and continually through the duration of the Work, the SSHO shall inspect the Site and document area-specific and worker-specific protection requirements.
 - H. After mobilization, the SSHO shall monitor activities and shall document the need for additional worker protection as required, based on activities performed and Action Levels specified in the HASP.
 - I. The SSHO shall, on a daily basis, verify that all activities are performed in accordance with the HASP and all federal, state, local, and Health and Safety standards, regulations, and guidelines.
 - J. In the event of a health or safety risk, as determined by the SSHO or by other Contractor personnel or by the Construction Manager, Contractor shall not proceed with the Work until a method for handling the risk has been determined in consultation with the

Construction Manager and implemented. Any health or safety risk resulting in a stoppage of Work shall be reported immediately to the Construction Manager.

- K. The Contractor shall be responsible for implementing a “Behavior Based Safety” process and providing site training, observation, and feedback for Contractor personnel employed at the Site.
- L. The Contractor shall be responsible for stability of excavations and embankments caused by the Contractor’s Work. Contractor shall designate one competent person as defined in 29 CFR Part 1926, Subpart P, Excavations, to inspect and document excavation safety conditions daily, and to ensure excavation safety prior to any personnel entering an excavation.

1.06 SUBMITTALS

- A. The Contractor shall prepare and submit a Health and Safety Plan (HASP) to the Architect/Engineer in accordance with General Conditions Article 4.7, for review and approval, as part of its startup submittals in accordance with Section 012901. The Contractor will not be able to perform any work on the Project until the HASP is approved.
- B. The Contractor shall follow all applicable local, State, and Federal Health and Safety standards, regulations, and guidelines implemented through, but not limited to, the OSHA, NIOSH, ACGIH, and USEPA. Where these are in conflict, the most stringent requirement shall be followed. The following points shall be addressed in the Contractor’s HASP:
 - 1. Names of key personnel and alternates responsible for Health and Safety, including a Contractor Health and Safety Representative and SSHO. The Construction Manager must approve the SSHO.
 - 2. A Health and Safety risk or Job Safety and Hazard Analysis (JSHA) associated with each portion of the Work (i.e., list potential chemical and physical hazards), including JSAs for excavation work around active utilities, excavation safety, and truck traffic into and out of the Site.
 - 3. Employee and Subcontractor training assignments to assure compliance with 29 CFR 1910.120.
 - 4. A requirement that the Contractor notify the New Jersey One Call System (811) to locate public utilities prior to the start of the Work.
 - 5. Personal protective equipment (PPE) to be used for each of the site tasks and operations being conducted, as required by the PPE program in 29 CFR 1910.120 and 29 CFR 1926.

6. Medical surveillance requirements in accordance with the program in 29 CFR 1910.120.
7. Frequency and types of air monitoring, personnel monitoring, and environmental sampling techniques and instrumentation to be used by the Contractor, including methods of maintenance and calibration of monitoring and sampling equipment.
8. Corrective actions and upgrading of personnel protection based on monitoring of air, personnel, and environmental sampling, with specific Action Levels identified.
9. Site control measures in accordance with the control program required in 29 CFR 1910.120 and 29 CFR 1926.
10. Decontamination procedures in accordance with 29 CFR 1910.120 and Contract Section 025100 and Section 014150.
11. An emergency response plan meeting federal, state, and local requirements for safe and effective responses to emergencies, including the necessary PPE and other equipment must be incorporated into the HASP. Explanation of potential emergencies and contingency plan of action, including description of the route to the nearest appropriate hospital, hospital route map, and posting of emergency telephone numbers at the Site.
12. If confined space entry is required, include confined space entry procedures in accordance with 29 CFR 1910.146 and training, and a list of all anticipated confined space entries required by Contractor in the course of the Work.
13. A spill containment program meeting the requirements of all applicable local, state, and federal Health and Safety standards.
14. A list of Health and Safety and emergency equipment available on the Site.
15. A description of engineering controls used to reduce the hazards of equipment operation and exposure to site hazardous chemicals.
16. An air monitoring plan describing the method, type, frequency, locations of air monitoring, laboratories, and type of analysis to be performed at the Work area for the purpose of employee safety and safety of the general public.
17. Open trench excavation procedures in accordance with applicable OSHA Regulations.
18. Procedures for earthwork near buried utilities, where hand digging should be performed within 24 inches of known utility lines unless more stringent requirements are specified by law, Regulation, or the affected utility.

19. Training for emergency response procedures, Heat stress program consistent with the references, Cold stress program consistent with the references, Lockout/Tagout where the operation of machinery and/or equipment in which the unexpected energization on start-up or the release of stored energy could cause injury to personnel.
- C. The Contractor’s Daily Construction Report shall include a summary of daily safety issues and a summary of Contractor’s Daily Safety Meeting.
- D. The Contractor shall submit monthly health and safety reports that include:
1. The names of all Contractor and Subcontractor personnel employed at the Site at any time during the month, and the names and duties of key personnel including Contractor’s Project Manager, Project Superintendent, SSHO, and excavation-competent person.
 2. A summary of all Health and Safety incidents describing any medical treatment that was provided during the month, the current Work status of any individuals affected the names of individuals who may have observed the incident, and actions taken by Contractor to address the unsafe act or unsafe condition.
 3. A summary of all Health and Safety near-misses or observations providing an opportunity for shared learning and future hazard avoidance. For any Health or Safety incident or near-miss, list the date, the nature of the incident or near-miss, and the names of individuals involved. A near-miss form for use in submitting near-misses is attached to this Section.
 4. The total number of labor hours worked at the Site during that month.
 5. Internal Health and Safety audits performed by the Contractor as part of the Contractor’s HASP.
 6. Results of Contractor behavioral observation and feedback evaluations.
- E. Prior to initiating Work, Contractor shall provide the Construction Manager with documentation of employee and applicable Subcontractor training and medical certifications required by 20 CFR 1910.120 as described in Paragraph 3.01.A of this Section.
- F. The Contractor shall submit documentation of training and experience for the designated excavation-competent person.
- G. The Contractor shall maintain all required and applicable training and medical monitoring rerecords on-site.

- H. The Contractor shall submit a Hot Work Permit, using the form attached to this Section, for any welding, torch cutting, or activities that generate sparks.
- I. The Contractor shall conduct a JSHA for significant activities and submit the documentation to the Construction Manager for review prior to the start of the activities. Contractor's JSHA shall be submitted on the JSHA forms attached to this Section, or other form acceptable to the Construction Manager.
- J. The Contractor shall submit copies of all periodic crane, pile-driver, and drill rig inspections completed.

1.07 NOTIFICATIONS

- A. The Contractor shall immediately (within 30 minutes) verbally report to the Construction Manager the occurrence of any and all Health and Safety incidents. An Incident Report form or Near-Miss Report form, as appropriate, attached to this Section, shall be submitted within 24 hours of occurrence of the incident or issue.
- B. The Contractor shall immediately and fully investigate any such incident or near miss and conduct a root cause analysis, and shall submit to the Construction Manager, the Contractor's written corrective action plan for such incident within one day after the incident occurs in accordance with General Conditions 4.7.
- C. The Contractor shall notify the Construction Manager in writing at least five (5) days prior to bringing any hazardous material, equipment, or process to the Site, or using the same on the Site. Contractor shall provide the Construction Manager with a Safety Data Sheet (SDS) for all chemicals brought on to the Site.
- D. The Contractor shall immediately notify the Construction Manager in writing of any hazard that Contractor discovers or observes on the Site and corrective measures planned or taken to eliminate or minimize such hazard. Hazard reporting will be completed as a Near Miss Report as described in of this Section.

PART 2 - PRODUCTS

2.01 EQUIPMENT AND FACILITIES

- A. The Contractor shall provide all equipment, temporary facilities, and personnel required to perform activities on site safely in accordance with all Regulations and standards, and with the Contractor's HASP.

2.02 PERSONAL PROTECTIVE EQUIPMENT

- A. The appropriate level of PPE shall be determined by the Contractor for specific tasks as described in the Contractor's HASP. If hazards are identified that require a level of

- protection greater than Level C, Work shall be suspended, and the Construction Manager notified. The Contractor's SSHO, shall determine what actions are required prior to restarting Work. The Contractor shall determine and document the appropriateness of suggested minimum PPE requirements for Contractor's employees and others at the Site.
- B. The Contractor shall furnish and maintain materials and equipment for the Health and Safety of Contractor employees, its subcontractors, suppliers, the DEP, the Construction Manager, and visitor personnel. Contractor shall provide all required Health and Safety equipment, first aid equipment, tools, monitoring equipment, PPE, and ancillary equipment and methods required to ensure workers' Health and Safety and to comply with the Contractor's HASP.
- C. Modified Level D protection will be required at all times while on site by all personnel and visitors on the Site, except in Support Zone areas. Level D PPE consists of:
1. Hard hat.
 2. Safety-toed boots (chemical resistant).
 3. Safety glasses with permanent side shields.
 4. Work clothes (long pants, shirts with sleeves).
 5. Work gloves.
 6. High visibility reflective safety vests.
 7. Hearing protection (as needed to prevent exposure exceeding 85 dB level).
- D. If additional protection consisting of Level C PPE is required during the Work, Level C PPE shall include protection from organic compounds and consist of Level D protection with the following additions:
1. Air purifying respirator, half-face or full-face (depending on required protection factor) with organic vapor/High Efficiency Particulate Air cartridges meeting NIOSH/Mine Safety and Health Administration Specifications.
 2. Disposable poly-coated chemically protective coveralls.
 3. Disposable chemically resistant outer gloves (nitrile).
 4. Disposable chemically resistant inner gloves (nitrile).
 5. Chemically resistant, steel-toed, and steel-shanked boots (PVC, neoprene, or nitrile), or outer booties.

- E. In most cases, Level C will be the maximum allowed level of PPE. Level B may be allowed provided that personnel are properly trained, and certified and exposure levels are below immediately dangerous to life and health (IDLH) conditions.

2.03 OTHER HEALTH AND SAFETY EQUIPMENT

- A. Contractor is required to have the following equipment available on the Site for the Health and Safety of Contractor, subcontractors, suppliers, the DEP, the Construction Manager, and visitors:
 - 1. First aid kits.
 - 2. Fire suppression equipment (appropriate to location and type of flammable materials present).
 - 3. OSHA-approved emergency eyewash facilities.
 - 4. Personnel decontamination facilities and equipment.
 - 5. Other equipment or supplies as determined to be necessary or prudent by Contractor or the Construction Manager.
 - 6. Flammable liquids storage cabinet, if necessary.
 - 7. Fall protection equipment.
 - 8. Heavy Blankets.

PART 3 - EXECUTION

3.01 TRAINING

- A. The Contractor shall provide the following training to each worker except those who will be restricted to the Support Zone:
 - 1. Initial 40-hour (or 80-hour where appropriate) OSHA hazardous waste Health and Safety training and current annual 8-hour refresher training.
 - 2. Eight-hour OSHA hazardous waste supervisory training (required for the Contractor's Superintendent and SSHO).
 - 3. Enrollment in a medical monitoring program, with clearance within the previous 12 months from a licensed physician allowing the worker to participate in field activities and use respiratory protective equipment. The Contractor shall not submit detailed medical information for employees.

4. Current respiratory fit testing certification.
 5. Current cardiopulmonary resuscitation (CPR) and first aid certification for at least two workers assigned to Work on the Site.
 6. For one who is assigned the role of a “competent person,” documentation of sufficient and relevant training and experience to perform the assigned duties and responsibilities of that role. As defined in 29 CFR 1926.31, the competent person shall be “one who is capable of identifying existing and predictable hazards, and who has authority to take prompt corrective measures to eliminate them.” Relevant training and experience shall be in the same type of Project activities included in the Work under this Contract.
- B. The Contractor shall designate one “competent person” as defined in 29 CFR Part 1926, Subpart P, Excavations, to inspect and document excavation safety conditions daily, and to ensure excavation safety prior to any personnel entering an excavation.

3.02 WORK PLANNING AND MEETINGS

- A. The Contractor shall conduct a daily Health and Safety meeting, prior to beginning Work for that day, to address Health and Safety issues, changing site conditions, activities and personnel. All Contractor and Subcontractor employees working on the site on that day shall attend the meeting. All meetings shall be documented, and attendees shall sign acknowledgement of their presence at the meeting. Daily meetings shall include a Safety Task Analysis Review (STAR) evaluation of the Work to be conducted and to document meeting attendance and discussion points. The STAR evaluation and daily safety meeting shall be documented on STAR forms, which are attached to this Section.
- B. Subcontractor personnel who are not in attendance for the daily Health and Safety meeting shall be briefed on the meeting notes upon arrival at the site and prior to commencing their Work activities. Employees shall sign acknowledgement of briefings prior to commencing Work.
- C. The Contractor shall hold and document additional safety meetings at the start of each major task and whenever site conditions affecting personnel safety change. Any major task undertaken shall require the completion of a JSHA as described in Paragraph 1.05.H of this Section.

3.03 ENGINEERING CONTROLS

- A. The Contractor shall, at a minimum, provide the following engineering controls to reduce the hazards of equipment operation and exposure to site hazardous chemicals:
1. Roll-over cages for bulldozers, back hoes, loaders, and tractors.

2. Back-up alarms for all trucks and moving equipment.
 3. Wetting of soil or other means to control dust during the Work.
 4. Decontamination of personnel and equipment in accordance with Section 025100 and Section 014150.
 5. Barricades for open trenches and excavations.
 6. Sloping, benching, shoring, drainage systems, or other controls as necessary to ensure stability of excavations and embankments.
 7. Providing a dedicated flag person to manage truck traffic along public ROWs (if deemed necessary by Construction Manager).
 8. Others as determined to be necessary or prudent by Contractor or as directed by the Construction Manager.
- B. The Contractor shall post ground level warning signs every 50 feet below all overhead utilities on site.

3.04 MONITORING

- A. The Contractor shall perform heat exposure and cold exposure monitoring activities as required by weather conditions.
- B. The Contractor shall perform all air monitoring activities described in the Contractor's HASP required to provide Health and Safety protection to the Contractor's and Subcontractor's personnel.
- C. The Site Perimeter Community Air Monitoring shall be conducted by the Contractor. Weekly reports shall be submitted for review.

3.05 EVALUATION OF PERFORMANCE

- A. The Contractor shall routinely conduct internal safety audits on Subcontract and Sub-subcontract Work sites in accordance with the Contractor's HASP. The focus of these routine audits will be on compliance with OSHA and local occupational safety regulations.
- B. The Contractor shall conduct routine behavioral observations and provide immediate feedback during Work activities to promote safe behavior of Contractor employees and Subcontractor employees. The Contractor behavioral observation and feedback sampling will be conducted in accordance with the Contractor's BEST observation and feedback process which is attached at the end of this Section.

END OF SECTION 014150

HEALTH AND SAFETY FORMS FOLLOW

EHS INCIDENT REPORT

Section One: Background Information

Your Name _____ Today's Date _____
Company Name _____ Site Name _____
Project Manager _____ Project Number _____
Project Name _____

Were there any witnesses to the incident? Yes No

If yes, list name(s)/office locations (including Contractors):

Was weather a factor? (Check one) Yes No

If yes, please describe weather conditions:

Section Two: Injury, Illness and Exposure

Was there an injury, illness or exposure associated with this incident?

Yes No

If yes, please complete this section.

If no, please proceed to Section Three.

Name of Injured: _____ Job Title: _____
Male/Female: _____ Date of Hire: _____
Date of Birth: _____ SSN: _____
Date/Time of Injury/Exposure: _____ Time Employee Began Work: _____
Supervisor: _____ H&S Coordinator: _____
Log Number: _____

Employee's Home Address: _____

NOTE: the Occupational Safety and Health Administration requires the above information for regulatory reporting.

Where did the incident occur (place name, address)?

Please describe the incident:

Was injured person/persons using required PPE? (Circle one) Yes No
Were there any unsafe conditions at the time of the incident? (Check one) Yes No

If yes, please describe:

Please describe what the employee was doing just before the incident (was there an unsafe act involved?):

What was the severity of the injury / exposure (please check):

First Aid Only Medical Treatment Only Fatality Non-Occupational No Treatment Necessary

What was the nature of the injury / exposure (please check):

<input type="checkbox"/> Fractures	<input type="checkbox"/> Blisters	<input type="checkbox"/> Heat Exhaustion	<input type="checkbox"/> Dislocations
<input type="checkbox"/> Respiratory Allergy	<input type="checkbox"/> Toxic Respiratory	<input type="checkbox"/> Exposure	<input type="checkbox"/> Concussion
<input type="checkbox"/> Heat Burns	<input type="checkbox"/> Toxic Ingestion	<input type="checkbox"/> Faint/Dizziness	<input type="checkbox"/> Abrasions
<input type="checkbox"/> Chemical Burns	<input type="checkbox"/> Cold Exposure	<input type="checkbox"/> Toxic Respiratory	<input type="checkbox"/> Lacerations
<input type="checkbox"/> Radiation Burns	<input type="checkbox"/> Frostbite	<input type="checkbox"/> Dermal Allergy	<input type="checkbox"/> Punctures
<input type="checkbox"/> Bruises	<input type="checkbox"/> Heatstroke	<input type="checkbox"/> Ergonomic	<input type="checkbox"/> Sprains
<input type="checkbox"/> Bites	<input type="checkbox"/> Other:		

Parts of Body Affected (Specify Right/Left):

Date medical care was received: _____

Was employee taken to the emergency room? Yes No

Was employee hospitalized overnight as an in-patient? Yes No

Facility Where Medical Care Was Received:

Clinic/Hospital Name: _____

Name of Attending Physician: _____

Clinic/Hospital Address: _____

Clinic/Hospital Telephone Number: _____

Section Three: Environmental Incident

Did one of the following occur: a spill to land over one quart, any spills to surface water, a significant release to the air, a violation of permit conditions, receipt of a Notice of Violation, or an event that causes potentially significant damage to the environment?

Yes No

If yes, please complete this section.

What type of environmental incident occurred?

Spill to Land Spill to Water Release to Air Permit Violation Notice of Violation Other

If other, specify:

Please describe the incident in detail:

If the incident was a spill or release, what material was involved and what amount?

Was there a violation of permit limits associated with the incident?

Yes

No

If yes, list permits and issuing agencies:

Were the required regulatory agencies notified?

Yes

No

If yes, which agencies were notified?

Section Four: Property Damage / Loss

Did the damage exceed \$500.00

Yes No

If yes, please complete this section.

What type of loss and/or property damage occurred?

Equipment Failure Collision Contamination Weather Fire Vandalism/Theft Other

If other, specify:

Describe the incident of loss or damaged property in detail (Contractor's):

Describe the incident of loss or damage of property in detail (3rd Party):

Was an insurance representative contacted? Yes No
If yes, list name of agent and time

What was the approximate cost of the loss / property damage?

Section Five: Analysis and Corrective Action

Were there any behavioral factors that contributed to the incident? (Check one) Yes No
If yes, please describe (describe any unsafe acts or conditions):

What can be done to prevent a recurrence of this type of incident?

List corrective actions that were taken to prevent this type of incident in the future:

Person Responsible for taking corrective action:

Forward this form within 24 hours to the Construction Manager

Contractor's SSHO Signature _____ Date _____

Contractor's Site Manager Signature _____ Date _____

CONTRACTORS ARE REQUIRED TO SUBMIT A ROOT CAUSE ANALYSIS TO THE CONSTRUCTION MANAGER FOR ALL INCIDENTS.

EHS Opportunity or Near Miss Reporting

EHS OPPORTUNITY OR NEAR MISS REPORT

Reported by:

Incident Date/Time:

Date Reported:

Site Location:

Report Type (check one):

EHS Opportunity (suggestion for improvement, good EHS idea to share, or EHS observation)

EHS Near Miss (event that could have resulted in an incident under different circumstances)

Event Description:

Describe key aspects such as the operation in progress, worker experience, potential outcome of event, and any contributing conditions. Use additional sheets as necessary.

Hazard Category (check all that apply):

Slip/trip/fall

Traffic/vehicle

Plant/Animal

Chemical

Electrical

Faulty equipment

Weather

Not following procedures

Fire

Improper PPE

Improper body position/tool use

Other: _____

Possible Outcome (check all that apply):

Injury/illness

Property damage

Environmental release

Were you able to correct the problem?

Yes

No

If no, whom did you inform: _____

N/A

Potential Outcome if Circumstances Occurred:

Corrective Action Taken:

HOT WORK PERMIT

Permit Valid

For 1 Work Day

Site Name: _____

Project Number: _____

EHS Officer: _____

Client: _____

Hot Work Description: _____

Workers/Welders Conducting Hot Work: _____

Permit MUST be completed in its Entirety Before Hot Work Begins

	Yes	No
Has Project supervisor been notified of intended Hot Work?		
Does client representative need to be notified of the intended Hot Work?		
Will Hot Work impact the general public, clients, or operation employees?		
Will the intended Hot Work need to be coordinated with other contractors who may be working on the site to make them aware of any hazards and the scope of work to be performed?		
Have hazardous energy sources been identified, isolated, and locked out/tagged out before the start of the Hot Work?		
Will Hot Work be conducted within a confined space?		
All testing equipment (i.e., CGI, oxygen meter, etc.) and firefighting equipment (i.e., extinguisher, etc.) have been checked to ensure proper operation and calibration before the start of this Hot Work?		
Has a fire watch been designated and on station?		
Have coatings on metal surfaces been tested for ignitability and flame spread?		
Has the area been cleared of all flammable materials?		
Have all fuel sources been identified and protected?		
Has the area been restricted with proper barriers and signs?		
Has the area been tested to be certain that atmosphere is 0% LEL before starting Hot Work?		
Have flame sensitive areas and equipment (including cylinders and gas delivery lines) exposed to slag and sparks been protected by flame resistant blankets or removed from the area?		
Have all equipment and hoses been protected from falling metal structures and debris?		
Have escape routes been identified before starting work?		
Is ventilation equipment needed? Type needed:		

The Following Protective Equipment Will be Required:

	Yes	No		Yes	No
Welding Goggles/Shield Tint			Supplied Air Respirator		
Safety Boots			Head Protection		
Leather gloves			Safety Harness		
Hearing Protection			Welding Leathers – Top		
APR Cartridge			Welding Leathers – Bottom		

Permit Valid for 1 Work Day

The following procedures will be applicable prior to Hot Work on tanks or other types of enclosed structures. (Check all that apply and fill in appropriate information.)

- Ventilate to 0% LEL
- Confined Space Entry Permit
- Mechanical Ventilation Required
- Cold Cut Only Method Allowed: _____
- Hot Cutting Permitted Method Allowed: _____

Inert to < _____ % Oxygen

Approvals:

_____ Date

_____ Construction Manager

_____ Site Safety and Health Officer

_____ Fire Watch

_____ Performed Hot Work Employee

File Permit in Project Work File and Health and Safety Department

JOB SAFETY AND HAZARD ANALYSIS

JSHA Type: <input type="checkbox"/> Investigation <input type="checkbox"/> O&M <input type="checkbox"/> Office <input type="checkbox"/> Construction	<input type="checkbox"/> New <input type="checkbox"/> Revised	Date:
--	---	-------

Office: Client: none Location:

Work Type:	Work Activity:
------------	----------------

Personal Protective Equipment (PPE):

Development Team	Position/Title	Reviewed By	Position/Title	Date

○ Job Steps	○ Potential Hazard	○ Critical Actions

**SAFETY
TASK ANALYSIS REVIEW
(STAR)**

TASK DESCRIPTION: _____

LIST TASKS

LIST ADDITIONAL HAZARDS (HAZARDS NOT SHOWN WITH CHECK BOX)

LIST ADDITIONAL CONTROLS (CONTROLS NOT SHOWN WITH CHECK BOX)

TAILGATE MEETING TOPIC

Signatures of Personnel on Task Analysis Review/Tailgate Meeting

MENTOR ASSIGNED TO WORK

LESSONS LEARNED
(Based on changes in work, changes in conditions, HSE Near-Incidents/Observations, Potential Emergencies)
IS THERE A BETTER/SAFER WAY TO PERFORM THE WORK/TASK?

COMPLETED BY: _____
JOB LOCATION: _____

Company: _____
Date: _____

SUPERVISOR REVIEW (date/time): _____

HSE REVIEW (date & time): _____

COMMENTS:

IDENTIFY POTENTIAL HAZARDS	IDENTIFY CONTROLS	PRE-TASK REVIEW (Yes/No/NA)
ABRASIONS	<input type="checkbox"/> AIR MONITORING	1. HAS A JOB HAZARD/SAFETY ANALYSIS BEEN COMPLETED AND REVIEWED? _____
BIOLOGICAL HAZARDS (plants, animals, insects)	<input type="checkbox"/> BARRICADES/FENCING/SILT FENCING	
CAVE-IN (trench/excavation work)	<input type="checkbox"/> BUDDY SYSTEM	2. IS JOB SCOPE UNDERSTOOD BY ALL PERSONNEL? _____
CHEMICAL/THERMAL BURN	<input type="checkbox"/> APPROPRIATE CLOTHING/MONITORING OF WEATHER	
CUTS	<input type="checkbox"/> CONFINED SPACE PROCEDURES	3. PROPER SAFETY EQUIPMENT ON JOB SITE? _____
DERMATITIS	<input type="checkbox"/> DECONTAMINATION PROCEDURES	
DROPPING MATERIALS/TOOLS TO LOWER LEVEL	<input type="checkbox"/> DRINKING WATER/FLUIDS	4. PERMIT ISSUED? _____ WHAT TYPE: HOT WORK _____ EXCAVATION _____ CONFINED SPACE _____ OTHER _____
DROWNING/FLOWING WATER	<input type="checkbox"/> DUST ABATEMENT MEASURES	
FUGITIVE DUST	<input type="checkbox"/> EQUIPMENT INSPECTION	5. PROPER TOOLS FOR JOB ON SITE? _____
ELECTRICAL SHOCK	<input type="checkbox"/> EXCLUSION/WORK ZONES	
ELEVATED/OVERHEAD WORK	<input type="checkbox"/> EXHAUST VENTILATION	6. OXYGEN/FLAMMABILITY CHECKED? _____
ENERGIZED EQUIPMENT	<input type="checkbox"/> FALL PROTECTION - TYPE	
FIRE	<input type="checkbox"/> FIRE EXTINGUISHER/FIRE WATCH	7. REVIEWED MSDS's FOR ANY HAZARDOUS SUBSTANCE THAT MIGHT BE PRESENT? _____
FLAMMABILITY	<input type="checkbox"/> FLOTATION DEVICES/LIFELINES	
FOREIGN BODY IN EYE	<input type="checkbox"/> GROUNDS ON EQUIPMENT/TANKS	8. PROPER TRAINING FOR ALL PERSONNEL? _____
HAZARDOUS MATERIALS (exposure or release)	<input type="checkbox"/> GROUND FAULT INTERRUPTER	
HEAT OR COLD STRESS	<input type="checkbox"/> GROUND HYDRAULIC ATTACHMENTS	9. ARE THERE ANY PLANNED DEVIATIONS FROM SET PROCEDURES OR EQUIPMENT MODIFICATIONS? _____ If so, contact supervisor to check applicability of MOC procedures.
HEAVY EQUIPMENT OPERATION	<input type="checkbox"/> HAND SIGNAL COMMUNICATION	
HEAVY LIFTING	<input type="checkbox"/> HAZARDOUS/FLAMMABLE MATERIAL STORAGE	10. IS THERE ANY WORK PLANNED THAT COULD CAUSE ACTIVATION OF EMERGENCY PROCEDURES? _____ If so, have these procedures been discussed and communicated?
HIGH NOISE LEVELS	<input type="checkbox"/> HAZARDOUS PLANT/ANIMAL TRAINING	
IMPACT NOISE	<input type="checkbox"/> HEARING PROTECTION (Specify)	POST-TASK REVIEW
INABILITY TO MAINTAIN COMMUNICATION	<input type="checkbox"/> HOSES, ACCESS TO WATER	
INCLEMENT WEATHER	<input type="checkbox"/> HOTWORK PROCEDURES	1. HAS WORK AREA BEEN CLEANED UP? _____
OVERHEAD WORK	<input type="checkbox"/> INSECT REPELLENT or PRECAUTIONS	
OVERHEAD UTILITIES	<input type="checkbox"/> ISOLATION OF EQUIPMENT OR PROCESS (LOCKOUT/TAGOUT)	2. HAVE ALL LOCKS/TAGS BEEN REMOVED AND SIGNED OFF BY INDIVIDUALS? _____
UNDERGROUND UTILITIES	<input type="checkbox"/> STORMWATER CONTROL PROCEDURES/METHODS	
PINCH POINTS	<input type="checkbox"/> MACHINE/EQUIPMENT GUARDS	3. HAVE WORK PERMITS BEEN TURNED IN? _____
PRESSURIZED LINES	<input type="checkbox"/> MANUAL LIFTING EQUIPMENT	
SLIPS, TRIPS, FALLS	<input type="checkbox"/> PROTECTIVE EQUIPMENT (specify)	4. STAR SUBMITTED TO HSE DEPARTMENT? _____
SPRAINS/STRAINS	<input type="checkbox"/> PROPER LIFTING TECHNIQUES	
TRAFFIC	<input type="checkbox"/> PROPER TOOL FOR JOB	5. WERE THERE ANY UNPLANNED DEVIATIONS FROM SET PROCEDURES OR EQUIPMENT MODIFICATIONS? _____
CONFINED SPACE	<input type="checkbox"/> RADIO COMMUNICATION	
NEW OR RENTAL EQUIPMENT	<input type="checkbox"/> RESPIRATOR, (specify type)	If so, contact supervisor to check applicability of MOC procedures.
SURFACE WATER RUN-ON/RUN-OFF	<input type="checkbox"/> SAFETY HARNESS/LANYARD/SCAFFOLD	
ODOR/VOC EMISSIONS	<input type="checkbox"/> SLOPING, SHORING, TRENCH BOX	
COMPRESSED GAS CYLINDERS	<input type="checkbox"/> VEHICLE INSPECTION	
GENERATED WASTES (solids/liquids)	<input type="checkbox"/> SPILL PREVENTION MEASURES/SPILL KITS	
KNOWN/UNKNOWN VISITORS	<input type="checkbox"/> EQUIPMENT MANUALS/TRAINING	
VISIBILITY	<input type="checkbox"/> EMERGENCY PROCEDURES/INCIDENT MANAGEMENT PLAN	
NEW PERSONNEL	<input type="checkbox"/> APPROPRIATE LABELS/SIGNAGE	
HOISTS/RIGGING/SLINGS/WIRE ROPE	<input type="checkbox"/> DERIVED WASTE MANAGEMENT PLAN	
SPECIAL OPERATIONS/INSTRUCTIONS (attach)	<input type="checkbox"/> VISITOR ESCORT/ORIENTATION/SECURITY	
ERGONOMICS	<input type="checkbox"/> WINDOW CLEANING/DEFROST	
	<input type="checkbox"/> PROPER WORK POSITION/TOOLS	

SECTION 014300 - QUALITY REQUIREMENTS

PART 1 - GENERAL

1.01 DESCRIPTION

- A. This Section covers Quality Assurance and Quality Control requirements for this Contract.
- B. The Contractor is responsible for controlling the quality of work, including work of its subcontractors and suppliers, and for assuring the quality specified in the Technical Specifications is achieved.
- C. Refer to General Conditions Article 4.4 - Responsibility for the Work
- D. Refer to the General Conditions Article 4.10 – Testing.

1.02 PAYMENT

- A. No separate payment shall be made for performing any Work required under this Section. All costs for Work required by this Section shall be included in the applicable lump sum, unit price(s), or allowance(s) as set forth in Section 012901.
- B. If the Contractor fails to perform the Quality Requirements in such circumstances, a monetary value can be deducted from the specified construction activity pertaining to the bid item. The exact monetary value of the inspection shall be at the sole discretion of the Construction Manager.

1.03 SUMMARY

- A. Section includes administrative and procedural requirements for quality assurance and quality control.
- B. Testing and inspecting services are required to verify compliance with requirements specified or indicated. These services do not relieve Contractor of responsibility for compliance with the Contract Document requirements.
 - 1. Specific quality-assurance and quality-control requirements for individual construction activities are specified in the Sections that specify those activities. Requirements in those Sections may also cover production of standard products.
 - 2. Specified tests, inspections, and related actions do not limit Contractor's other quality-assurance and quality-control procedures that facilitate compliance with the Contract Document requirements.

3. Requirements for Contractor to provide quality-assurance and quality-control services required by Construction Manager or authorities having jurisdiction are not limited by provisions of this Section.
4. The Contractor will be responsible for performing all the required special inspections for quality requirements to ensure specific Quality-Assurance and Quality-Control throughout the course of the contract. The requirements for individual construction activities as called forth in the Sections that specify those activities will be deemed inclusive of the pay items. The costs for all special inspections shall be considered incidental to the bid amount of each item. The Contractor will be responsible for all other inspections in obtaining additional test requirements in the instance that any Non-Conformance Reports (NCRs) are reported. No separate payment shall be made for any of these inspections, application fees, or any associated fees necessary for the proper execution and completion of the Work, and which are required by the EOR and included in the Contract Documents at the time of the bid.

C. Related Requirements:

1. General Conditions Article 4.4 – Responsibility for the Work
2. General Conditions Article 4.7 – Shop Drawings and Other Submittals
3. General Conditions Article 4.10 - Testing
4. General Conditions Article 4.15 – Uncovering and Correction of Work
5. General Conditions Article 4.16 – Layout and Dimensional Control
6. Divisions 02 through 40 Sections for specific test and inspection requirements.

1.04 REFERENCES

A. American Society for Testing and Materials (ASTM):

1. E329: Standard Specification for Agencies Engaged in Construction Inspection and/or Testing

1.05 DEFINITIONS

- A. Quality-Assurance Services: Activities, actions, and procedures performed before and during execution of the Work to guard against defects and deficiencies and substantiate that proposed construction will comply with requirements.
- B. Quality-Control Services: Tests, inspections, procedures, and related actions during and after execution of the Work to evaluate that actual products incorporated into the Work

and completed construction comply with requirements. Services do not include contract enforcement activities performed by Construction Manager.

- C. Mockups: Full-size physical assemblies that are constructed on-site. Mockups are constructed to verify selections made under Sample submittals; to demonstrate aesthetic effects and, where indicated, qualities of materials and execution; to review coordination, testing, or operation; to show interface between dissimilar materials; and to demonstrate compliance with specified installation tolerances. Mockups are not Samples. Unless otherwise indicated, accepted mockups establish the standard by which the Work will be accepted.
- D. Preconstruction Testing: Tests and inspections performed specifically for Project before products and materials are incorporated into the Work, to verify performance or compliance with specified criteria.
- E. Product Testing: Tests and inspections that are performed by a Nationally Recognized Testing Laboratory (NRTL), a National Voluntary Laboratory Accreditation Program (NVLAP), or a testing agency qualified to conduct product testing and acceptable to authorities having jurisdiction, to establish product performance and compliance with specified requirements.
 - 1. NRTL: A nationally recognized testing laboratory according to 29 CFR 1910.7.
- F. Source Quality-Control Testing: Tests and inspections that are performed at the source, e.g., plant, mill, factory, or shop.
- G. Field Quality-Control Testing: Tests and inspections that are performed on-site for installation of the Work and for completed Work.
- H. Testing Agency: An entity engaged to perform specific tests, inspections, or both. Testing laboratory shall mean the same as testing agency.
- I. Installer/Applicator/Erector: Contractor or another entity engaged by Contractor as an employee, Subcontractor, or Sub-subcontractor, to perform a particular construction operation, including installation, erection, application, and similar operations.
 - 1. Use of trade-specific terminology in referring to a trade or entity does not require that certain construction activities be performed by accredited or unionized individuals, or that requirements specified apply exclusively to specific trade(s).
- J. Experienced: When used with an entity or individual, "experienced" means having successfully completed a minimum of five (5) previous projects similar in nature, size, and extent to this Project; being familiar with special requirements indicated; and having complied with requirements of authorities having jurisdiction.

- K. Non-Conformance Report (NCR): A report issued by the Testing Agency and/or Construction Manager that addresses specification deviation or work that fails to meet quality standards. The Contractor shall use the NCR to determine a resolution and document all corrective changes made. Issuance of an NCR may include the following:
1. Work that was not built as indicated in the Contract Drawings.
 2. Work that fails to meet specified tolerances as established in the Contract Specifications.
 3. Work that is being performed using non-approved methods or standards.
 4. Failure to follow the approved testing and inspection plan.
 5. Testing results demonstrate that the product does not meet established and approved standards.
 6. Material used that has not been approved as a substitute (equal or similar).
 7. Approved procedure was not followed, and quality defects have been identified by the Construction Manager.

1.06 CONFLICTING REQUIREMENTS

- A. Referenced Standards: If compliance with two (2) or more standards is specified and the standards establish different or conflicting requirements for minimum quantities or quality levels, comply with the most stringent requirement. Refer conflicting requirements that are different, but apparently equal, to Construction Manager for a decision before proceeding.
- B. Minimum Quantity or Quality Levels: The quantity or quality level shown or specified shall be the minimum provided or performed. The actual installation may comply exactly with the minimum quantity or quality specified, or it may exceed the minimum within reasonable limits. To comply with these requirements, indicated numeric values are minimum or maximum, as appropriate, for the context of requirements. Refer uncertainties to Construction Manager for a decision before proceeding.

1.07 SUBMITTALS

- A. Refer to General Conditions Article 4.7
- B. Contractor's Quality-Control Plan: For quality-assurance and quality-control activities and responsibilities. Refer to General Conditions Section 4.10 testing for procedures and requirements.

- C. Qualification Data: For Contractor's quality-control personnel. This shall be submitted as part of the Contractor's Quality-Control Plan.
- D. Testing Agency Qualifications: Refer to General Conditions Section 4.10 for testing agency requirements. This shall be submitted as part of the Contractor's Quality-Control Plan.
- E. Schedule of Tests and Inspections: Prepare in tabular form and include the following:
 - 1. Specification Section number and title.
 - 2. Entity responsible for performing tests and inspections.
 - 3. Description of test and inspection.
 - 4. Identification of applicable standards.
 - 5. Identification of test and inspection methods.
 - 6. Number of tests and inspections required.
 - 7. Time schedule or time span for tests and inspections.
 - 8. Requirements for obtaining samples.
 - 9. Unique characteristics of each quality-control service.

This shall be submitted as part of the Contractor's Quality-Control Plan.

1.08 CONTRACTOR'S QUALITY-CONTROL PLAN

- A. Quality-Control Plan, General: Submit quality-control plan within ten (10) days of Notice to Proceed, and not less than five (5) days prior to preconstruction conference. Submit in format acceptable to Construction Manager. Identify personnel, procedures, controls, instructions, tests, records, and forms to be used to carry out Contractor's quality-assurance and quality-control responsibilities. Coordinate with Contractor's construction schedule.
- B. Quality-Control Personnel Qualifications: Engage qualified full-time personnel trained and experienced in managing and executing quality-assurance and quality-control procedures similar in nature and extent to those required for Project.
- C. Submittal Procedure: Describe procedures for ensuring compliance with requirements through review and management of submittal process. Indicate qualifications of personnel responsible for submittal review.

- D. Testing and Inspection: In quality-control plan, include a comprehensive schedule of Work requiring testing or inspection, including the following:
 - 1. Contractor-performed tests and inspections including subcontractor-performed tests and inspections. Include required tests and inspections as detailed in the Specifications and as required by the applicable Codes, Standards and Publications referenced as detailed or referenced in the Specifications, and Contractor-elected quality control tests and inspections.
 - 2. Special tests and inspections required by authorities having jurisdiction.
- E. Continuous Inspection of Workmanship: Describe process for continuous inspection during construction to identify and correct deficiencies in workmanship in addition to testing and inspection specified. Indicate types of corrective actions to be required to bring work into compliance with standards of workmanship established by Contract requirements and accepted mockups.
- F. Monitoring and Documentation: Maintain testing and inspection reports including log of accepted and rejected results. Include work Construction Manager has indicated as nonconforming or defective. Indicate corrective actions taken to bring nonconforming work into compliance with requirements and schedule. Comply with requirements of authorities having jurisdiction.

1.09 REPORTS AND DOCUMENTS

- A. Test and Inspection Reports: Prepare and submit certified written reports specified in other Sections. Include the following:
 - 1. Date of issue.
 - 2. Project title and number.
 - 3. Name, address, and telephone number of testing agency.
 - 4. Dates and locations of samples and tests or inspections.
 - 5. Names of individuals making tests and inspections.
 - 6. Description of the Work and test and inspection method.
 - 7. Identification of product and Specification Section.
 - 8. Complete test or inspection data.
 - 9. Test and inspection results and an interpretation of test results.

10. Record of temperature and weather conditions at time of sample taking and testing and inspecting.
 11. Comments or professional opinion on whether tested or inspected Work complies with the Contract Document requirements.
 12. Name and signature of laboratory inspector.
 13. Recommendations on retesting and re-inspecting.
- B. Manufacturer's Technical Representative's Field Reports: Prepare written information documenting manufacturer's technical representative's tests and inspections specified in other Sections. Include the following:
1. Name, address, and telephone number of technical representative making report.
 2. Statement on condition of substrates and their acceptability for installation of product.
 3. Statement that products at Project Site comply with requirements.
 4. Summary of installation procedures being followed, whether they comply with requirements and, if not, what corrective action was taken.
 5. Results of operational and other tests and a statement of whether observed performance complies with requirements.
 6. Statement whether conditions, products, and installation will affect warranty.
 7. Other required items indicated in individual Contract Sections.
- C. Factory-Authorized Service Representative's Reports: Prepare written information documenting manufacturer's factory-authorized service representative's tests and inspections specified in other Contract Sections. Include the following:
1. Name, address, and telephone number of factory-authorized service representative making report.
 2. Statement that equipment complies with requirements.
 3. Results of operational and other tests and a statement of whether observed performance complies with requirements.
 4. Statement whether conditions, products, and installation will affect warranty.
 5. Other required items indicated in individual Contract Sections.

- D. Permits, Licenses, and Certificates: For DEP's records, submit copies of permits, licenses, certifications, inspection reports, releases, jurisdictional settlements, notices, receipts for fee payments, judgments, correspondence, records, and similar documents, established for compliance with standards and regulations bearing on performance of the Work.

1.10 QUALITY ASSURANCE

- A. General: Qualifications paragraphs in this Section establish the minimum qualification levels required; individual Contract Sections specify additional requirements.
- B. Manufacturer Qualifications: A firm experienced in manufacturing products or systems similar to those indicated for this Project and with a record of successful in-service performance, as well as sufficient production capacity to produce required units.
- C. Fabricator Qualifications: A firm experienced in producing products similar to those indicated for this Project and with a record of successful in-service performance, as well as sufficient production capacity to produce required units.
- D. Installer Qualifications: A firm or individual experienced in installing, erecting, or assembling work similar in material, design, and extent to that indicated for this Project, whose work has resulted in construction with a record of successful in-service performance.
- E. Professional Engineer Qualifications: A professional engineer who is legally qualified to practice in jurisdiction where Project is located and who is experienced in providing engineering services of the kind indicated.
- F. Specialists: Certain Contract Sections require that specific construction activities shall be performed by entities who are recognized experts in those operations. Specialists shall satisfy qualification requirements indicated and shall be engaged for the activities indicated.
 - 1. Requirements of authorities having jurisdiction shall supersede requirements for specialists.
- G. Testing Agency Qualifications: An NRTL, or an independent agency with the experience and capability to conduct testing and inspecting indicated, as documented according to ASTM E329; and with additional qualifications specified in individual Sections; and, where required by authorities having jurisdiction, that is acceptable to authorities.
- H. Manufacturer's Technical Representative Qualifications: An authorized representative of manufacturer who is trained and approved by manufacturer to observe and inspect installation of manufacturer's products that are similar in material, design, and extent to those indicated for this Project.

- I. **Factory-Authorized Service Representative Qualifications:** An authorized representative of manufacturer who is trained and approved by manufacturer to inspect installation of manufacturer's products that are similar in material, design, and extent to those indicated for this Project.

- J. **Preconstruction Testing:** Where testing agency is indicated to perform preconstruction testing for compliance with specified requirements for performance and test methods, comply with the following:
 - 1. Contractor responsibilities include the following:
 - a. Provide test specimens representative of proposed products and construction.
 - b. Submit specimens in a timely manner with sufficient time for testing and analyzing results to prevent delaying the Work.
 - c. Build site-assembled test assemblies and mockups using installers who will perform same tasks for Project.
 - d. When testing is complete, remove mockups; do not reuse products on Project.
 - 2. **Testing Agency Responsibilities:** Submit a certified written report of each test, inspection, and similar quality-assurance service to Construction Manager, with copy to Contractor. Interpret tests and inspections and state in each report whether tested and inspected work complies with or deviates from the Contract Documents.

- K. **Mockups:** Before installing portions of the Work requiring mockups, build mockups for each form of construction and finish required to comply with the following requirements, using materials indicated for the completed Work:
 - 1. Build mockups of the following structures;
 - a. T-Wall with pilaster, including formliners to 8 feet above top of foundation
 - b. I-Wall, including formliners to 5 feet above grade.
 - c. Other mock-ups called for in the various Sections.

Note, pile supports and cutoff sheeting are not required for the floodwall mockups.
 - 2. Notify Construction Manager seven (7) days in advance of dates and times when mockups will be constructed.
 - 3. Employ supervisory personnel who will oversee mockup construction. Employ workers that will be employed during the construction at Project.
 - 4. Demonstrate the proposed range of aesthetic effects and workmanship.

5. Obtain EOR's acceptance of mockups before starting work, fabrication, or construction.
 - a. Allow seven (7) days for initial review and each re-review of each mockup.
 6. Maintain mockups during construction in an undisturbed condition as a standard for accepting the completed Work.
 7. Demolish and remove mockups when directed unless otherwise indicated.
- L. Laboratory Mockups: Comply with requirements of preconstruction testing and those specified in individual Contract Sections in Divisions 02 through 35.
- M. Codes and Standards: Refer to General Conditions Article 4.1 - Review of the Contract Documents and Field Conditions, paragraph 4.1.3 of the General Conditions.
- N. Copies of applicable referenced standards are not included in the Contract Documents. Where copies of standards are needed by the Contractor for superintendence and quality control of the work, the Contractor shall obtain a copy or copies directly from the publication source and maintain at the jobsite, available to the Contractor's personnel, subcontractors, and Construction Manager.
- O. Quality of Materials: Unless otherwise specified, all materials and equipment furnished for permanent installation in the Work shall conform to applicable standards and specifications and shall be new, unused, and free from defects and imperfections, when installed or otherwise incorporated in the Work. The Contractor shall not use material and equipment for any purpose other than that intended or specified unless the Construction Manager authorizes such use.
- P. Where so specified, products or workmanship shall also conform to the additional performance requirements included within the Contract Documents to establish a higher or more stringent standard or quality than that required by the referenced standard.
- 1.11 OFFSITE INSPECTION
- A. If the Contract Sections require that Work to be done away from the construction site is to be inspected on behalf of the DEP during its fabrication, manufacture, testing, and before shipment, the Contractor shall give notice to the Construction Manager of the place and time where such fabrication, manufacture, testing, or shipping is to be done. Such notice shall be in writing and delivered to the Construction Manager no less than 60 days prior so that the necessary arrangements for the inspection can be made.
 - B. The Contractor and the manufacturer/fabricator shall cooperate with and make safe and proper arrangements for the DEP and its agents to review and inspect the Work away from the site at the manufacturer/fabricator's facilities. The Contractor shall provide the

DEP with the following information at least five (5) working days prior to the scheduled inspection date:

1. A diagram of the proposed testing equipment.
 2. A description of the manufacturer/fabricator's inspection and testing facilities and procedures.
 3. A list of all instruments the manufacturer/fabricator proposes to use for the tests with initial and last calibration reports certified by an independent testing agency.
 4. Sample test data sheets.
 5. Sample calculations.
 6. Descriptive matter on the testing equipment which shall contain illustrative photographs, drawings and other such matter that may be requested by the DEP.
- C. The Contractor to provide six (6) copies of all inspection and test results, along with a certificate of authenticity sworn to, before a notary, by an officer of the manufacturing/fabricating company, to the Architect/Engineer (A/E) for review and approval.
- D. When witness shop tests are waived by the DEP, six (6) copies of the manufacturer/fabricator's actual test data and the interpreted results thereof, along with a certificate of authenticity sworn to by an office of the manufacturing/fabricating company, shall be forwarded to the A/E for review and approval.

1.12 MATERIALS AND EQUIPMENT

- A. The Contractor shall maintain control over procurement sources to ensure that materials and equipment conform to specified requirements in the Contract Documents.
- B. The Contractor shall comply with manufacturer's printed instructions regarding all facets of materials and/or equipment movement, storage, installation, testing, startup, and operation. Should circumstances occur where the Contract Documents are more stringent than the manufacturer's printed instructions, the Contractor shall comply with the specifications. In cases where the manufacturer's printed instructions are more stringent than the Contract Documents, the Contractor shall advise the Construction Manager of the disparity and conform to the manufacturer's printed instructions. In either case, the Contractor is to apply the more stringent specification or recommendation, unless accepted otherwise by the Architect/Engineer.

1.13 QUALITY CONTROL

- A. Contractor Responsibilities: Contractor has primary responsibility for all required quality control and assurance inspections and tests so that the Work complies with requirements of the Specifications, Drawings and references Standards and Codes. Contractor shall retain the services of qualified, certified, and licensed inspecting and testing agencies to perform the Quality Control and Assurance oversight as detailed in the approved Quality Control Plan.
1. The Contractor shall furnish a construction schedule and a minimum of 48-hour notice of readiness for testing and inspection of the work. The Construction Manager shall retain the option to witness Contractor field sampling and testing and may require such additional sampling and testing to determine that materials and equipment conform with data previously furnished by Contractor and with the Contract Documents.
 2. The Contractor shall schedule the work to permit adequate time for testing and re-testing should test results do not conform to the contract documents. Lack of testing or inspection will be cause for rejection of the work.
 3. Laboratory testing shall be performed within a reasonable time, consistent with the specified standards.
 4. The Contractor shall furnish material samples and cooperate in the field sampling and testing activities, interrupting the work when necessary. The Contractor shall furnish personnel, facilities and access to assist in the sampling and testing activities.
 5. Unless otherwise indicated, provide quality-control services specified and those required by authorities having jurisdiction. Perform quality-control services required of Contractor by authorities having jurisdiction, whether specified or not.
 6. Monitor quality control over suppliers, manufacturers, products, services, site conditions, and workmanship, to produce Work of specified quality.
 7. Comply with manufacturers' instructions, including each step-in sequence.
 8. When manufacturers' instructions conflict with Contract Documents, request clarification from Architect/Engineer before proceeding.
 9. Comply with specified standards as minimum quality for the Work except where more stringent tolerances, codes, or specified requirements indicate higher standards or more precise workmanship.
 10. Perform Work by persons qualified to produce required and specified quality.

11. Verify field measurements are as indicated on Shop Drawings or as instructed by manufacturer.
12. Secure products in place with positive anchorage devices designed and sized to withstand stresses, vibration, physical distortion, or disfigurement.
13. Contractor shall submit certified written reports, in duplicate, of each quality-control service.
14. Submit additional copies of each written report directly to authorities having jurisdiction, when they so direct.
15. Costs for retesting and re-inspecting construction that replaces or is necessitated by work that failed to comply with the Contract Documents will be at the sole cost and expense of the Contractor.

B. Tolerances:

1. Monitor fabrication and installation tolerance control of products to produce acceptable Work. Do not permit tolerances to accumulate.
2. Comply with manufacturers' tolerances. When manufacturers' tolerances conflict with Contract Documents, request clarification from Construction Manager before proceeding.
3. Adjust products to appropriate dimensions; position before securing products in place.
4. Manufacturer's Field Services: Where indicated, engage a factory-authorized service representative to inspect field-assembled components and equipment installation, including service connections. Report results in writing as called for in General Conditions Article 4.7.

C. Manufacturer's Technical Services: Where indicated, engage a manufacturer's technical representative to observe and inspect the Work. Manufacturer's technical representative's services include participation in preinstallation conferences, examination of substrates and conditions, verification of materials, observation of Installer activities, inspection of completed portions of the Work, and submittal of written reports.

D. Retesting/Re-inspecting: Regardless of whether original tests or inspections were Contractor's responsibility, provide quality-control services, including retesting and re-inspecting, for construction that replaced Work that failed to comply with the Contract Documents.

E. Testing Agency Responsibilities: Cooperate with Contractor in performance of duties. Provide qualified personnel to perform required tests and inspections.

1. Notify Contractor and Construction Manager promptly of irregularities or deficiencies observed in the Work during performance of its services.
 2. Determine the location from which test samples will be taken and in which in-situ tests are conducted.
 3. Conduct and interpret tests and inspections and state in each report whether tested and inspected work complies with or deviates from requirements.
 4. Submit a certified written report, in duplicate, of each test, inspection, and similar quality-control service through the Contractor.
 5. Do not reduce, revoke, alter, or increase the Contract Document requirements or approve or accept any portion of the Work.
- F. Associated Services: Cooperate with agencies performing required tests, inspections, and similar quality-control services, and provide reasonable auxiliary services as requested. Notify agency sufficiently in advance of operations to permit assignment of personnel. Provide the following:
1. Free and safe access to the Work.
 2. Incidental labor and facilities necessary to facilitate tests and inspections.
 3. Adequate quantities of representative samples of materials that require testing and inspecting. Assist agency in obtaining samples.
 4. Facilities for storage and field curing of test samples.
 5. Delivery of samples to testing agencies.
 6. Preliminary design mix proposed for use for material mixes that require control by testing agency.
 7. Security and protection for samples and for testing and inspecting equipment at Project site.
- G. Coordination: Coordinate sequence of activities to accommodate required quality-assurance and quality-control services with a minimum of delay and to avoid necessity of removing and replacing construction to accommodate testing and inspecting.
1. Schedule times for tests, inspections, obtaining samples, and similar activities.
- H. Schedule of Tests and Inspections: Prepare a schedule of tests, inspections, and similar quality-control services required by the Contract Documents and include in the

Contractor's Quality Control Plan Coordination Schedule and submit concurrently with Contractor's construction schedule. Update as the Work progresses.

1. Distribution: Distribute schedule to Construction Manager testing agencies, and each party involved in performance of portions of the Work where tests and inspections are required.
- I. DEP Responsibilities: DEP retains the option to perform supplementary or conformance quality-assurances services as it deems necessary to assure quality of construction. DEP will engage qualified testing agencies to perform these services.
 1. DEP will furnish Contractor with names, addresses, and telephone numbers of testing agencies engaged and a description of types of testing and inspecting they are engaged to perform.

1.14 SPECIAL TESTS AND INSPECTIONS

- A. Special Tests and Inspections: The Contractor shall engage independent qualified testing agencies, as required to conduct special tests and inspections required by authorities having jurisdiction, and as required by the applicable Codes, Standards and Publications referenced within specifications entitled REFERENCES, and as follows:
 1. Verifying that manufacturer maintains detailed fabrication and quality-control procedures and reviews the completeness and adequacy of those procedures to perform the Work.
 2. Notifying Construction Manager and Contractor promptly of irregularities and deficiencies observed in the Work during performance of its services.
 3. Submitting a certified written report of each test, inspection, and similar quality-control service to the Construction Manager with copy to the Contractor and to authorities having jurisdiction.
 4. Submitting a final report of special tests and inspections at Substantial Completion, which includes a list of unresolved deficiencies.
 5. Interpreting tests and inspections and stating in each report whether tested and inspected work complies with or deviates from the Contract Documents.
 6. Retesting and re-inspecting corrected work.

PART 2 - PRODUCTS

(Not Used)

PART 3 - EXECUTION

3.01 EXAMINATION

- A. Verify existing site conditions and substrate surfaces are acceptable for subsequent Work. Beginning new Work means acceptance of existing conditions.
- B. Verify existing substrate is capable of structural support or attachment of new Work being applied or attached.
- C. Examine and verify specific conditions described in individual specification sections.
- D. Verify utility services are available, of correct characteristics, and in correct locations.
- E. Survey lines and levels
 - 1. The A/E will supply information to establish co-ordinates and basic benchmarks. The Contractor shall verify the correctness of stakes and marks and perform survey and layout Work.
 - 2. The layout of new structures is based on the connections and relationships with the existing structures. Dimensions shown require verification and adjustment as the existing structures are exposed.
 - 3. The Contractor shall expose the existing structures. The Contractor shall confirm existing dimensions both above and below grade.
 - 4. The Contractor shall provide accurate measurements to the Construction Manager. The Contractor shall coordinate with the dimensions shown on the Contract Drawings and propose the final dimensions to be used for the layout. The Contractor shall await the Construction Manager's review and complete the layout to the approved dimensions.
 - 5. The Contractor shall establish the required lines, elevations and grades. The Contractor shall erect and protect batterboards, Site lines and reference boards, during excavation and construction of structures.
 - 6. The Contractor shall carefully protect all benchmarks and reference points.
 - 7. The Contractor shall periodically verify by instrument, reference marks and Site lines. The Contractor shall be responsible throughout the Contract for the accuracy of lines and levels.
 - 8. The Construction Manager may, from time to time, verify lines, elevations, grades, reference marks, and batterboards. The Contractor shall correct any errors in lines,

elevations, grades, reference marks and batterboards disclosed by the verification of the Construction Manager.

3.02 PREPARATION

- A. Clean substrate surfaces prior to applying next material or substance.
- B. Seal cracks or openings of substrate prior to applying next material or substance.
- C. Apply manufacturer required or recommended substrate primer, sealer, or conditioner prior to applying new material or substance in contact or bond.

3.03 QUALITY CONTROL

- A. Quality control is the responsibility of the Contractor, and the Contractor shall maintain control over construction and installation processes to assure compliance with specified requirements.
- B. Certifications for personnel, procedures, and equipment associated with special processes (e.g., welding, cable splicing, instrument calibration, surveying) shall be maintained in the Contractor's field office, available for inspection by the Construction Manager. Copies shall be made available to the Construction Manager upon request.
- C. Means and methods of construction and installation processes are the responsibility of the Contractor, and at no time is it the intent of the Construction Manager to supersede or void that responsibility.

3.04 TEST AND INSPECTION LOG

- A. Test and Inspection Log: Prepare a record of tests and inspections. Include the following:
 - 1. Date test or inspection was conducted.
 - 2. Description of the Work tested or inspected.
 - 3. Date test or inspection results were transmitted to Construction Manager.
 - 4. Identification of testing agency or special inspector conducting test or inspection.
- B. Maintain log at Project site. Post changes and revisions as they occur. Provide access to test and inspection log for Construction Manager's reference during normal working hours.

3.05 REPAIR AND PROTECTION

- A. General: On completion of testing, inspecting, sample taking, and similar services, repair damaged construction and restore substrates and finishes.

1. Provide materials and comply with installation requirements specified in other Specification Sections or matching existing substrates and finishes. Restore patched areas and extend restoration into adjoining areas with durable seams that are as invisible as possible. Comply with the Contract Document requirements for cutting and patching in General Provisions Article 4.9.
- B. Protect construction exposed by or for quality-control service activities.
- C. Repair and protection are Contractor's responsibility, regardless of the assignment of responsibility for quality-control services.

END OF SECTION 014300

SECTION 015000 - TEMPORARY FACILITIES AND CONTROLS

PART 1 - GENERAL

1.01 SCOPE OF WORK

- A. The Contractor shall provide all temporary services, utilities, and facilities, including payment of utility costs for the proper completion of the work, as required and as specified.

1. Section includes:

a. Project identification:

- (1) Project signs.

b. Temporary Facilities:

- (1) Field offices and sheds.

- (2) Office for Construction Manager, NJDEP and EOR.

c. Equipment.

d. Support facility installation.

e. Security and Protection.

f. Operation, termination, and removal.

1.02 PAYMENT

- A. All costs for Work required by this Section shall be included in the applicable lump sum(s), unit price(s), or allowance(s) as set forth in Section 012901.

1.03 REFERENCES

- A. See individual Contract Sections for appropriate references.

1.04 RELATED SECTIONS

- A. General Conditions Article 4.7 – Shop Drawings and Other Submittals
B. General Conditions Article 4.12 – Temporary Facilities
C. General Conditions Article 4.13 – Storage and Site Maintenance

D. Section - 14300 – Quality Requirements

E. Section 012901 – Measurement and Payment

1.05 PROJECT IDENTIFICATION

A. Project Identification Sign:

1. Provide three (3) signs as shown on the attached drawing.
2. Each painted sign, 32 sq. ft. area, bottom 6 feet above ground.

B. Submit drawing of proposed sign for Construction Manager’s approval.

C. Design sign and structure to withstand 60 miles/hr. wind velocity.

D. Sign Painter: Experienced as professional sign painter for minimum three (3) years.

E. Finishes, Painting: Adequate to withstand weathering, fading, and chipping for duration of construction.

F. Sign Materials:

1. Structure and framing: new wood structurally adequate.
2. Sign surfaces: Exterior grade plywood with medium density overlay, minimum 3/4-inch thick, standard large sizes to minimize joints.
3. Rough Hardware: Galvanized.
4. Paint and Primers: Exterior quality, two (2) coats; sign background of white color.
5. Lettering: Exterior quality paint, colors as selected by the EOR.

G. Installation:

1. Install project identification sign within 15 days after Notice to Proceed.
2. Erect as shown on the Contract Drawings or as directed by the Construction Manager.
3. Erect supports and framing on secure foundation, rigidly braced, and framed to resist wind loadings.
4. Install sign surface plumb and level, with butt joints. Anchor securely.
5. Paint exposed surfaces of sign, supports, and framing.

H. Maintenance: Maintain signs and supports clean, repair deterioration, and damage.

I. Removal: Remove signs, framing, supports, and foundations at completion of Project and restore the area.

1.06 TRAFFIC REGULATION

A. Signs, Signals, and Devices:

1. See Contract Sections and Maintenance and Protection of Traffic (MPT) Plans.

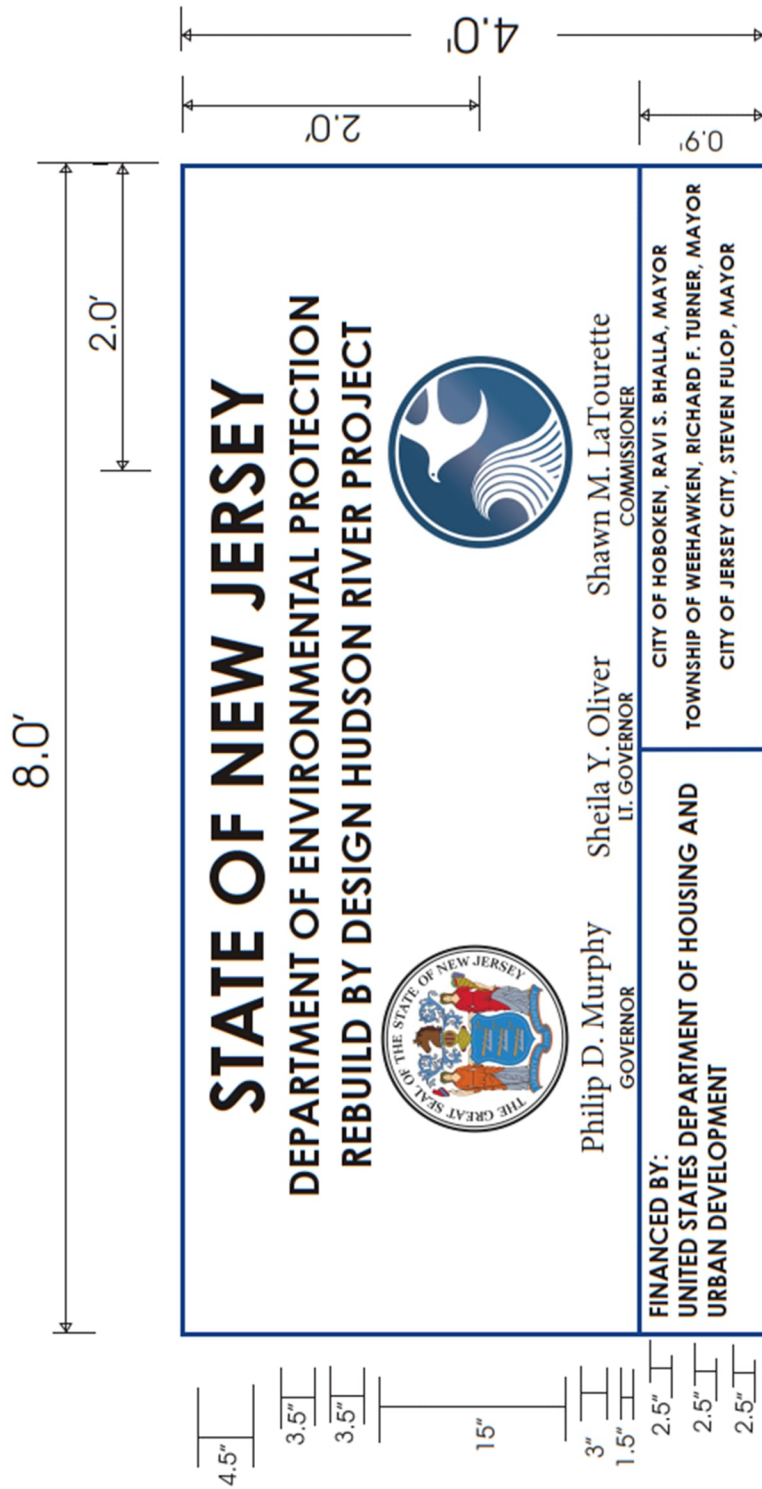

- * State of New Jersey, Department of Environmental Protection and Rebuild by Design Hudson River Project to be centered across sign.
- * Governor Lt. Governor and Commissioner Names and title to be centered with seals.
- * Sign border and lines shall be blue.
- * Logos should be centered on each half of sign
- * Seals to be provided by NJDEP
- * Dimensions identified on left are letter and logo sizes. Vertical spacing shall be as appropriate.

B. Uniformed Traffic Directors:

1. Provide uniformed traffic directors, provided by municipal police force, NJ Transit or Hudson County in the municipality where the work is occurring. Cost for uniformed traffic directors will be paid under the appropriate Allowance Item.

C. Flares and Lights: Use flares and lights during hours of low visibility to delineate traffic lanes and to guide traffic.

D. Haul Routes:

1. Consult with authority having jurisdiction, establish public thoroughfares to be used for haul routes and site access.
2. Confine construction traffic to designated haul routes.
3. Provide traffic control at critical areas of haul routes to regulate traffic, to minimize interference with public traffic.

E. Traffic Signs and Signals:

1. Refer to Maintenance and Protection of Traffic Plans and Specifications.
2. Signs are to be covered until needed.

F. Removal:

1. Remove equipment and devices when no longer required.
2. Repair damage caused by installation.
3. Remove post settings to depth of 2 feet.

1.07 SUBMITTALS

- A. Refer to General Conditions Article 4.7 for submittal requirements.
- B. Site Plan: Show temporary facilities, utility hookups, staging areas, and parking areas for construction personnel.
- C. Soil Erosion and Sedimentation Control (SESC) Plan: Show compliance with requirements of Hudson County Soil Conservation District.

1.08 QUALITY ASSURANCE

- A. Electric Service: Comply with NECA, NEMA, and UL standards and regulations for temporary electric service.

- B. Contractor to contact PSE&G for temporary power services. Contractor is responsible for all temporary service fees. Include power to all trailers and temporary power for testing electric services at the gates and other power needs on the Project.
- C. As shown on the Drawings, contractor to provide the disconnect and meter box (if required) and all conduit, wiring and devices. PSE&G will install service to the disconnect/meter box. Install service to comply with NFPA 70.
- D. Tests and Inspections: Arrange for authorities having jurisdiction to test and inspect each temporary utility before use. Obtain required certifications and permits.

1.09 PROJECT CONDITIONS

- A. During adverse weather and against the possibility thereof, the Contractor shall take all necessary precautions so that the Work is properly performed and is satisfactory in all respects. When required, protection shall be provided by use of tarpaulins, wood and building-paper shelters, temporary heat, water curing, or other suitable means.
- B. During cold weather, materials shall be preheated, if required, and the materials and adjacent structure into which they are to be incorporated shall be made and kept sufficiently warm so that a proper bond will take place and a proper curing, aging, or drying will result. Protected spaces shall be artificially heated by suitable means that will result in a moist or a dry atmosphere according to the particular requirements of the work being protected. Ingredients for concrete and mortar shall be sufficiently heated so that the mixture will be warm throughout when used.

PART 2 - PRODUCTS

2.01 MATERIALS

- A. Portable Chain-Link Fencing: Minimum 2-inch, 0.148-inch- thick, galvanized-steel, chain-link fabric fencing; minimum six (6) feet high with galvanized-steel pipe posts; minimum 2-3/8-inch- OD line posts and 2-7/8-inch- OD corner and pull posts, with 1-5/8-inch- OD top and bottom rails.

2.02 CONSTRUCTION FACILITIES

- A. The Contractor shall provide construction facilities, including payment of utility costs, including the following:
 - 1. Field Offices, General: Prefabricated or mobile units with serviceable finishes, temperature controls, and foundations adequate for normal loading.
 - 2. The Contractor shall maintain a temporary field office near the work for his own use during the period of construction at which readily accessible copies of all

Contract Documents shall be kept. The office shall be located where it will not interfere with the progress of the work.

3. Temporary Storage Yards: The Contractor shall construct temporary storage yards for storage of Products that are not subject to damage by weather conditions.
4. Temporary Storage Buildings:
 - a. The Contractor shall provide environmental control systems that meet the recommendations of suppliers and manufacturers of the equipment and materials stored.
 - b. The Contractor shall arrange for a chain link partition fence to provide security of contents and ready access for inspection and inventory.
5. The Contractor shall store combustible materials (paints, solvents, fuels) in a well ventilated and remote building meeting all applicable safety standards.

2.03 OFFICE FOR CONSTRUCTION MANAGER

- A. Prior to Mobilization, the Contractor shall provide and equip a primary and secondary office space to be located within the vicinity of the northern and southern resist alignments, respectively. The primary office space shall consist of one thousand (1,000) square footage of office space for exclusive use of the Construction Manager & NJDEP and an additional four hundred (400) square footage of office space for the exclusive use of the EOR that is separate from the Construction Manager's office space. The secondary office space shall consist of 200 square footage of office space that shall be mutually shared for use of the Construction Manager, NJDEP and EOR. Primary office space shall be separate from the Contractor's office space, located in Hoboken and no further than one-quarter mile from the project limits of the northern resist alignment, and in a location that will not interfere with the progress of the work. Secondary office space shall be separate from the Contractor's office space, located no further than one-quarter mile from the project limits of the southern resist alignment, and in a location that will not interfere with the progress of the work. The use of Cove Park for the primary office space is acceptable; however, the Contractor shall reestablish office space when it interferes with the work in the Cove Park area. The new office space shall not be more than one-quarter mile from the location of the major work remaining at the time of reestablishment. If the office space needs to be relocated during the course of work, the Contractor shall coordinate the relocation to ensure that suitable office space is available and provided for the Construction Manager, NJDEP, and EOR at all times. Any permits that are required for the office space shall be obtained by the Contractor at no cost to the State. Office spaces can be in the form of an acceptable, suitably constructed and equipped trailers of adequate size and design for the purpose or rented office space in an existing building. Primary office space shall conform to all the requirements listed in Section 2.03.

Secondary office space shall conform to 2.03 A.1, 2, 3; B; C.1.d, 1.f, 2, 3, 4, 5, 6; D; E.1, 2, 3, 4, 5, 6, 11, 13, 17, 18, 21, 22, 25, 28, 29, 30; F; G; H; I; and J.

1. If a trailer is furnished, it shall have a minimum width of 12 feet, and a length as required to obtain the square footage specified below and an insulated floor. The Contractor will need to request approval from the Hoboken Zoning Officer on a form provided by the Hoboken Zoning Office. The Contractor is encouraged to review the Hoboken Temporary Use requirements and restrictions prior to bidding.
 2. The office and furniture shall be relatively new and in good condition.
 3. The equipment, supplies, and services furnished shall be acceptable to the Construction Manager.
- B. The Contractor shall furnish insurance coverage of adequate amount to replace not only the Contractor's equipment, but all property belonging to the Construction Manager and the Construction Manager's staff, at replacement cost.
- C. The Office shall be of suitable height and of ample size to accommodate the furniture and equipment listed below, without crowding (at least one thousand (1,000) sq. ft. of floor area for the Construction Manager's office and four hundred (400) sq. ft. of floor area for the EOR's office). It shall be weathertight and acceptably insulated and suitably ventilated; the floor shall be tight and of sufficient construction to withstand the loads imposed upon it.
1. The office shall be partitioned so as to provide separate rooms as follows:
 - a. Two (2) private offices for the Construction Manager's office.
 - b. Four (4) offices in open area complete with partition walls for the Construction Manager's office.
 - c. Two (2) offices in open area complete with partition walls for the EOR's office.
 - d. One (1) private conference/meeting room for the Construction Manager's office.
 - e. One (1) lunch area/kitchenette complete with sink, counter and storage cabinets for each of the Construction Manager's and EOR's offices.
 - f. Two (2) private washrooms (1 male and 1 female).
 - g. One (1) storage/drawing room or each of the Construction Manager's and EOR's offices.

2. Each room will have a door, with lock and key. If a trailer is provided each room will have a minimum of two (2) screened windows which can be both opened and locked shut.
 3. If a trailer is provided, the offices shall each have two (2) exterior doors, with cylinder locks and keys. If rented office space in an existing building is provided, each office shall have an exterior door, with lock and keys
 4. If a trailer is provided, the exterior doors shall also be provided with a hasp, for which the Construction Manager will furnish his own locks.
 5. The office shall contain acceptable toilet facilities, to include a toilet, sink with hot and cold water, exhaust fan, and mirror.
 6. The Contractor shall make arrangements and pay all costs associated with tying the office water system into utility water supply system.
 7. The Contractor shall make arrangements and pay all costs associated with tying the office sanitary system into an approved disposal system.
- D. The Contractor shall furnish a parking area large enough to accommodate a minimum of five (5) cars adjacent to the office, for the exclusive use of the Construction Manager, NJDEP, and EOR.
- E. The Contractor shall furnish the following furniture, equipment, supplies, and services:
1. One plan table or sloping plan shelf for each of the Construction Manager's and EOR's offices, about 3 feet by 6 feet, with a reasonably smooth top, and one (1) suitable swivel stool.
 2. Eight (8) additional folding chairs.
 3. Shelves, tables, and bookcases as recommended by the Construction Manager.
 4. Electric lights, desk lamps and outlets as recommended by the Construction Manager. The Contractor shall pay for installation and all charges for the energy used.
 5. Broom and dustpan.
 6. Two (2) desks for general office use. Each about three (3) feet by five (5) feet, all with a desk chair of the armchair swivel type.
 7. Plan rack, accepted by the Construction Manager.
 8. Plan storage cabinet as accepted by the Construction Manager.

9. Two (2) four-drawer, legal size, metal filing cabinets each with locks. The Contractor shall furnish up to two (2) additional filing cabinets if requested by the Construction Manager.
10. Private line, touch-tone telephones with internal electronic that allows the telephone to be used on both touch-tone and digital pulse services. Telephone to be ATT or equal. Provide touch-tone service where available. A phone shall be furnished for conference/meeting room. One line service and intercom feature shall be provided. The Contractor shall pay all charges for local calls.
11. Class ABC type fire extinguisher of at least four (4) pound capacity.
12. Insulated waterproof chest for storage and moist curing of concrete cylinders; size and construction with capability of maintaining required curing temp.
13. Supply of drinking water in a suitable dispenser, with hot and cold supply and refrigerator space.
14. Refrigerator (Frigidaire 18 Cu. Ft. Compact Refrigerator, Samsung, GE or approved equal).
15. Coffee maker with supply of coffee and insulated cups to be resupplied weekly or as requested by the Construction Manager.
16. Microwave.
17. Paper cups, paper towels, liquid soap, and toilet paper; each with suitable dispenser or holder to be resupplied weekly or as requested by the Construction Manager.
18. A waste basket for each desk, and a supply of appropriately sized plastic trash bags.
19. A four-drawer, lockable file cabinet for each office.
20. One (1) four-drawer fireproof file cabinet.
21. Thermostatically controlled heating unit or system of adequate capacity to maintain a minimum temperature of not less than 68 degrees F under all cold weather conditions. The Contractor shall provide all fuel used and service necessary.
22. Thermostatically controlled, refrigerant type, air conditioner of adequate capacity to maintain a maximum temperature of not more than 72 degrees F under all hot weather conditions. The Contractor shall provide all service necessary and provide all power used.
23. Metal clothing locker, or closet, 36-inches wide by 18-inches deep by 72-inches high, minimum dimensions.

24. Metal storage cabinet 36-inches wide, by 18-inches deep by 72-inches high, with a minimum of five (5) adjustable shelves, and a door lock.
 25. The Contractor shall arrange for complete janitor service to be provided on a weekly basis.
 26. Outdoor minimum-maximum thermometer with range of -40 degrees F to +120 degrees F reset provisions.
 27. 200-foot reel-mounted stainless-steel Engineer's tape, Richter No. RI 553112, Lufkin, Stanley or approved equal.
 28. Printer: "All-in-one" unit equipped with printer server, combining color printing, photocopying, scanning, and faxing, or separate units for each of these three functions. Printer shall be capable of wireless printing. Printer shall also be capable of copying and scanning 8.5"x11", 8.5"x14", and 11"x17" paper sizes. Copy rate shall be at least 20 copies per minute for 8.5"x11" paper size. Ink, & paper to be resupplied as requested by the Construction Manager.
 29. Internet Service: Broadband modem, router, and ISP, equipped with hardware firewall, providing unlimited data of minimum 200Mbps upload and 200 Mbps download speeds at each computer and works with Microsoft Windows 10 and higher. Wireless (WiFi) internet service shall be provided.
 30. Internet Security: Integrated software, providing software firewall, virus, spyware, phishing, and spam protection in a combined application.
 31. Backup: External hard drive, minimum five (5) terabyte, with automated backup software providing daily backups.
- F. The Contractor shall provide office space and facilities until the office, furnishings, and equipment described above are ready for use, but by so doing he shall not be relieved of his obligation to provide and equip the specified Construction Manager's office as promptly as possible.
- G. Unless otherwise directed by the Construction Manager, after the date of completion of the Work as stated in the final estimate, the Contractor shall remove the office and all such temporary facilities from the site, the same to become his property, and leave the premises in a condition acceptable to the Construction Manager.
- H. The printer and copying machine furnished as part of the office for the Construction Manager shall become the property of the Contractor at final completion of the Project.
- I. Remove snow and ice as required to minimize accumulations for the safety of all personnel.

- J. Contractor shall provide office space and facilities in compliance with guidelines and directives issued by the New Jersey Department of Health, the CDC, and the Occupational Health and Safety Administration, as applicable, for maintaining a clean, safe, and healthy work environment. Contractor shall be aware that office space and facilities may require changes throughout the duration of the project based on current guidelines and directives. The Contractor and all onsite personnel will be required to comply with the attached memo issued by the DPMC on June 28, 2021, regarding COVID, or latest applicable requirements.

2.04 EQUIPMENT

- A. Fire Extinguishers: Portable, UL rated; with class and extinguishing agent as required by locations and classes of fire exposures.

PART 3 - EXECUTION

3.01 INSTALLATION, GENERAL

- A. Locate facilities where they will serve Project adequately and result in minimum interference with performance of the Work. Relocate and modify facilities as required by progress of the Work.
- B. Provide each facility ready for use when needed to avoid delay. Do not remove until facilities are no longer needed.

3.02 TEMPORARY SERVICES

- A. General: Install temporary service and utilities or connect to existing service.
 - 1. Arrange with utility company to make connections for temporary services.
 - 2. Costs for installation, removal, and use of temporary facilities shall be included in the Contract Sum unless otherwise indicated. Allow other entities to use temporary services and facilities without cost, including, but not limited to, NJDEP, Construction Manager, Engineer, testing agencies, and authorities having jurisdiction.
 - 3. Notwithstanding the availability of potable water and effluent water services from the existing system, The Contractor shall be solely responsible for the provision of water for leakage and other testing, for concrete curing and protection and to prevent freezing of equipment, as required by the Contract.
- B. Sewers and Drainage: Provide temporary utilities to remove effluent lawfully.

1. Connect temporary sewers to North Hudson Sewerage Authority or Jersey City system as directed by authorities having jurisdiction.
 2. Pay sewer-service connection fees and use charges for sewer usage by all entities for construction operations.
 - a. The Contractor shall provide adequate sanitary facilities for the use of those employed on the Work. Such facilities shall be made available when the first employees arrive on the site of the Work, shall be properly secluded from public observation, and shall be constructed and maintained during the progress of the Work in suitable numbers and at such points and in such manner as may be required by pertinent health and safety regulations.
 - b. The Contractor shall maintain the sanitary facilities in a satisfactory and sanitary condition at all times and shall enforce their use. The Contractor shall rigorously prohibit the committing of nuisances on the site of the Work, on the lands of the Owner, or on adjacent property.
- C. Water Service (potable and non-potable): Install temporary service or connect to existing service.
1. Water from utility's existing water system is available for use with metering and payment of connection fees and use charges. Install water service and distribution piping in sizes and pressures adequate for construction.
 - a. The Contractor shall furnish all necessary pipe or hose extensions to conduct the water to the points of use and shall exercise due care not to waste water. The Contractor shall not contaminate the water supply and shall comply with all applicable regulations and code requirements.
 2. Pay all water-service use charges for potable water used by all entities for construction operations.
 3. At Substantial Completion, disconnect and seal water connection at the direction of the utility.
- D. Sanitary Facilities: Provide temporary toilets, wash facilities, and drinking water for use of construction personnel. Comply with requirements of authorities having jurisdiction for type, number, location, operation, and maintenance of fixtures and facilities.
1. Pay sewer connection fees and service use charges for sewer usage by all entities for construction operations.
- E. Heating and Cooling: Provide temporary heating and cooling required by construction activities for curing or drying of completed installations or for protecting installed construction from adverse effects of low temperatures or high humidity. Select

equipment that will not have a harmful effect on completed installations or elements being installed.

1. If temporary heat is required for the protection of the Work, the Contractor shall provide and install suitable heating apparatus, shall provide adequate and proper fuel, and shall maintain heat as required. Costs for temporary heating, cooling, and ventilating required to execute the Work shall be borne by the Contractor.
 2. The Contractor shall provide 24-hour monitoring of temporary heating, cooling and ventilating equipment.
- F. Lighting and Electric Power Service: Provide lighting and electric power service and distribution system of sufficient size, capacity, and power characteristics required for construction operations.
1. Electric power from utility's existing system is available for use with metering and payment of use charges. The Contractor shall make all necessary applications and arrangements and pay all fees and charges for electrical energy for power and light necessary for the proper completion of the Work and during its entire progress. The Contractor shall provide and pay for all temporary wiring, switches, connections, and meters.
 2. The Contractor shall provide sufficient electric lighting so that all work may be done in a workmanlike manner when there is not sufficient daylight.
 - a. Provide temporary lighting with local switching that provides adequate illumination for construction operations, observations, inspections, and traffic conditions.
 - b. Contractor shall provide a construction lighting plan that details the lighting required for construction operations and shall include, but is not limited to, lighting locations, operational hours of lighting, light pollution mitigation measures, and measures of reducing and/or preventing intrusive or distracting lighting to the surrounding community during construction operations.
- G. Temporary and Permanent Facilities Light and Power: The Contractor shall extend sufficient electrical service for all temporary and permanent load centers feeding public and park right-of-way lighting, floodwall lighting, signs, amenities, and electrically operated flood gates.
1. Temporary and permanent electrical service shall be three phase or single phase as indicated in the Contract Documents and required by the equipment installed in the project. The Contractor is responsible to investigate and verify the appropriateness and availability of electrical service with the local utility company. Temporary and permanent light and power installations, wiring, and miscellaneous electrical hardware must meet the electrical Code and will be inspected by NJUCC officials.

The Contractor shall provide the necessary distributing facilities and a meter and shall pay the cost of running temporary services from the nearest utility company power source.

Contractor shall contact PSE&G for all temporary and permanent power services needed for the Contract work. The Contractor shall initiate and obtain Electric Service Agreements for each required service feed location. The Contractor's bid shall be deemed to include all costs associated with providing temporary and permanent power for the project and pay for the cost of all electric energy used on distribution lines installed.

2. Electric Service: Comply with NECA, NEMA, and UL standards and regulations for temporary and permanent electric services. The Contractor shall provide and pay for all maintenance, servicing, operation and supervision of the service and distribution facilities.
3. Contractor to provide the disconnect and meter box, as shown on the drawings or required, and all conduit, wiring and devices. PSE&G will install service to the disconnect/meter box. Install service to comply with NFPA 70.
4. Tests and Inspections: Arrange for authorities having jurisdiction to test and inspect each temporary utility before use. Obtain required certifications and permits.
5. If the Contractor fails to carry out its responsibility in the supplying uninterrupted light and power as set forth herein, the Contractor shall be held responsible for such failure, and the DEP Project Director shall have the right to take such action as is deemed proper for the protection and conduct of the Work.

All costs associated with DEP Project Director obtaining or supplying light and power shall be deducted from any payment due to the Contractor.

6. Upon acceptance of the final installation and testing, the Contractor shall prepare, complete and file all required documents to transfer Electrical Service Accounts to the NJDEP as directed by the Construction Manager in accord with Section 017700.

3.03 SUPPORT FACILITIES INSTALLATION

- A. Parking: Provide parking areas for construction personnel. The Contractor shall not use public roads or undesignated areas for parking.
- B. Materials Storage: Provide adequate space for materials storage and laydown area.

3.04 SECURITY AND PROTECTION FACILITIES INSTALLATION

- A. Protection of Existing Property: Protect existing vegetation, equipment, structures, utilities, and other improvements at Project site and on adjacent properties, except those indicated to be removed or altered. Repair damage to existing facilities.
 - 1. Use of site enclosure, barricades, warning signs, and lights.
 - 2. Building enclosure and lock up protocols.
- B. Environmental Protection: Provide protection, operate temporary facilities, and conduct construction to comply with environmental regulations and that minimize possible air, waterway, and subsoil contamination or pollution or other undesirable effects.
- C. Pest Control: Engage pest-control service to recommend practices to minimize attraction and harboring of rodents, mosquitos, and other pests and to perform extermination and control procedures at continuing and regular intervals so the Project will be free of pests and their residues at Substantial Completion. Perform control operations lawfully, using environmentally safe materials.
 - 1. Technical Specifications
 - a. Definitions
 - (1) “Rodent” refers to but not limited to the common rat and mouse species and their young found such as sewer rat, roof rat and house mouse.
 - (2) “Mosquito” in the Contract means the adult mosquito, including its egg, larva and pupa capable of carrying or causing any disease to human beings.
 - (3) “Permanently destroy” refers to treatment, removal and eradication of mosquito and rodent.
 - (4) “Construction Manager (CM) means construction site management or DEP authorized representative and also such person or persons as may be deputed by him in writing to act on his behalf for the purpose of this Contract.
 - b. Scope of Services
 - (1) Contractor shall make provisions for rodent and mosquito surveillance and control services prior to and throughout the entire construction duration/project/contract for the following:

- (a) To provide rodent control services to eradicate rodents and harboring sites
 - (b) To detect and permanently destroy the mosquito breeding and harboring sites
 - (c) To provide advice on interim or permanent measures for the destruction of potential breeding and harboring sites of rodents and mosquitoes
- (2) Rodent and mosquito surveillance and control services shall include all disturbed areas within the construction site, and not limited to the following:
- (a) All areas designated on the drawings within the Limit of Work (L.O.W.),
 - (b) Contractor Storage Yards, Machinery and Truck Parking Areas
 - (c) Vehicle Wash Bays,
 - (d) Trash and Concrete Washout Locations,
 - (e) Contractor Staff Parking Areas
 - (f) Trash and Waste Transfer Areas
 - (g) Contractor and Construction Manager Trailer / Office areas
- (3) The Contractor shall provide all manpower, materials, equipment and everything else necessary to carry out the services in accordance with the Contract Specifications and the Conditions of Contract.

c. Rodent Control Services

- (1) Service Requirements
 - (a) The Contractor shall be responsible to carry out a baseline survey to identify the state of rodent infestation, signs of rodent infestation e.g., droppings, rub marks, gnaw marks, live rodents etc. and environmental irregularities/lapses that contributed to the infestation.
 - (b) The following should be carried out:
 - i. Inspect all areas within the construction site Limit of Work (L.O.W.) and designated in the Scope of Services.

- ii. Identify rodent burrows/nests in the immediate surroundings e.g.
- iii. Gather information on signs of rodent activity from stakeholders
- iv. Identify irregularities detected in housekeeping, storage and waste disposal that are contributing to rodent infestation and make recommendations for rectification/follow-up action by CM.
- v. Identify potential rodent entry/exit points and make recommendations for rectification/follow-up actions by S.O.
- vi. Highlight signs of rodent infestation (e.g., rub marks, rodent droppings, burrows, etc.)
- vii. Use of special equipment e.g., night vision infrared camera and borescope to verify status of rodent infestation, if necessary
- viii. Carry out all other forms of rodent surveillance, where necessary or as instructed by S.O.
- ix. Carry out treatment to destroy rodents in all stages of their life cycle:
 - x. Where required and permitted carry out treatment by using trapping devices e.g., glue and cage traps at strategic locations where rodent activities have been detected.
 - xi. Carry out outdoor treatment by deploying tamper-resistant bait stations (with rodenticide baits, provided safety is not compromised) at high-risk location(s)
 - xii. Remove carcasses of dead rodents, disinfect and deodorize area accordingly
 - xiii. Seal all inactive rodent burrows in the outdoors one (1) month after completion of treatment
 - xiv. Carry out night inspections and treatment as and when necessary

- (c) In the event of heavy rodent infestation (e.g., repeated rat sightings in a specific area as defined by the CM), the contractor shall carry out intensified containment measures.
 - (d) Investigate and carry out rodent treatment after receiving feedbacks and/or notifications on rodents by the public or CM. A thorough investigation is also to be carried out to determine the cause(s) of infestation. Such activities are to be reported to the CM upon completion as well as reported in the service report.
 - d. Work and Service Standards
 - (1) The Contractor shall ensure that his staff are equipped with proper tools, pesticides and all other materials/equipment that is necessary for all services specified in the Contract.
 - (2) All pesticides, regardless of packaging, shall be placed either in locations not accessible to children, pets, wildlife and domestic animals, or in tamper-resistant bait stations.
 - (3) If bait stations are used, the Contractor shall ensure:
 - (a) All bait stations are placed out of the general view, and in locations where they will not be interfered or be disturbed during routine operations
 - (b) The lids of all bait stations are securely locked or fastened and only authorized personnel will be able to open them
 - (c) All bait stations are securely attached or anchored to floor, ground, wall or other immovable surface, so that they cannot be easily removed
 - (d) Baits are secured in the feeding chamber of the stations and not placed at the exit hole of the stations or along the rat runway
 - (e) All bait stations are properly labelled with the Contractor's business name and telephone number with the words "Rodent Bait Station, Do Not Remove" printed on it
 - e. The Contractor shall submit a proposal for rodent control program for the area within the construction site and should include the following:
 - (1) Define the location and extent of the service areas based on the layout plan provided by CM.

- (2) Service Report (including photographs of affected areas) on pest situation (no. of rodent, species caught etc.) and advice on housekeeping and rat-proofing measures
- (3) Night surveillance and control recommended
- (4) Option for ‘Intensive Treatment’ depending on rodent situation
- (5) Sketch plans showing all rodent monitoring stations, including traps and outdoor tamper resistant baiting stations, etc., if applicable
- (6) The Contractor shall carry out the frequency of surveillance to all areas within the construction site, but contractor may increase its frequency or conduct surveillance to other areas when deemed necessary or as instructed by CM.
- (7) In the event of heavy rodent infestation, intensified rodent treatment and containment measures are to be carried out as instructed by CM.

f. Work Report

- (1) The Contractor shall furnish a full baseline report for all rodent burrows, activity and environmental irregularities detected by the second week after the commencement of the Contract or at the beginning of each construction stage.
- (2) The Contractor shall furnish a service report for all rodent control services performed at the end of each service. It shall also recommend specific solutions to prevent rodent infestation such as building design details, structural modifications, repairs, housekeeping program, user habits and all other factors that have direct bearing on rodent infestation. Photos of each rodent burrow or structural defect and the respective treatment to eradicate rodents taken from different perspectives/ angles are required to be included in the reports. At the end of each month, the Contractor shall furnish a monthly service report. The report shall consolidate the findings and the outcomes of the action taken for the month. The CM reserves the right to withhold any payment to the Contractor for failure to perform required inspections and treatments in any monthly period.

g. Employment of Qualified and Licensed Personnel

- (1) The Contractor shall ensure that no unlicensed vector control technicians or uncertified vector control workers are to be employed by him or any subcontractor, in the execution of any part of the works. The Contractor shall note that the employment of any unlicensed/uncertified vector

control technicians/workers to carry out vector control work shall be considered a failure of compliance with the requirements of the Contract. All pest control work shall be performed in accord with the applicable requirements of 1974 CDC Urban Rat Surveys Manual.

- (2) The Contractor shall engage supervisors and technicians to ensure the efficient execution of the works to the satisfaction of the CM. They shall also carry out all instructions/ directions issued by the CM. and such instructions/ directions shall be deemed to be instructions/directions given to the Contractor.
- (3) The Contractor shall submit a list of names and licenses of all the technicians and workers to be deployed by him under the Contract before the commencement of the contract and shall ensure that only such licensed technicians or certified workers are to be deployed for all Works carried out under the Contract. The Contractor shall provide an updated manpower list to the CM as and when there are changes in deployment arrangements or when the CM. requires.

h. Pesticides & Safety Data Sheets

- (1) Upon taking over the service site(s), the Contractor shall select and decide on the appropriate type of pesticides to be used for all treatment/maintenance. The Contractor shall provide updated OSHA Safety Data Sheets (SDS) for all pesticides proposed to be used during vector control services at the construction sites, for inspection by the authority or CM. upon demand. Should there be a change of pesticides used during the contract period, the Contractor shall submit new updated SDS and inform CM on the new selection.
- (2) The Contractor shall also take the initiative to update the CM with new and updated SDS should the existing SDS become invalid.

i. Safety Precautions

- (1) The Contractor shall provide all personnel working at the service areas designated under the Contract, distinctive and proper attire and appropriate footwear etc., and ensure that they are worn. all additional personal protective equipment required for the safe performance of work must be determined and provided by the Contractor in accordance with recommendations on the SDS for each pesticide.
- (2) The Contractor shall be responsible to take every safety precaution to eliminate dangers to his vector control technicians/ workers, the general public and property of others. The Contractor must not compromise on

the safety measures taken on site and shall ensure that there shall be no incidents of safety issues or breaches.

- D. Fire extinguishers: In addition to supplying a minimum of one (1) ABC fire extinguisher in each construction office, fire extinguishers shall be placed as required in or near construction vehicles, generators, or other flammable storage areas.
- E. Snow and ice removal, if applicable.

3.05 CLEANING CONSTRUCTION OFFICES DURING CONSTRUCTION

- A. Contractor to maintain the grounds within his working limits, including the temporary office trailer and site used by the Contractor, Construction Manager and Engineer, and around any equipment or storage areas. This includes removal of waste material, cutting of grass, weed whacking around storage racks and material, snow plowing, and snow shoveling.
- B. The Contractor shall make arrangements with, and obtain permits from, any authorities having jurisdiction for disposal of waste and debris.
- C. The Contractor shall wet down exterior surfaces prior to sweeping to prevent blowing of dust and debris. At least weekly, the Contractor shall sweep all floors (basins, tunnels, platforms, walkways, roof surfaces), and pick up all debris and dispose of off Site.
- D. The Contractor shall provide approved containers for collection and disposal of waste materials, debris, and rubbish. At least at weekly intervals, the Contractor shall dispose of such waste materials, debris, and rubbish off Site.
- E. At least weekly, the Contractor shall brush sweep entry drive and roadways, and all other streets and walkways affected by the Work and where adjacent to the Work.

END OF SECTION 015000

SECTION 015300 - TEMPORARY RETAINING STRUCTURES

PART 1 GENERAL

1.01 SCOPE

- A. This Work shall consist of designing, furnishing, installing, maintaining and subsequently removing all temporary retaining structures required to complete this project. The Contractor shall be solely responsible for the design, layout, construction, maintenance, and subsequent removal and disposal of all elements of the temporary retaining structures. Temporary retaining structures shall be required as shown on the Plans or required by the Construction Manager or Architect/Engineer.

1.02 PAYMENT

- A. Payment for temporary retaining structures including design, installation, maintenance, removal, and any incidental work as required will be included in the price for other items in the Bid. Such price and payment shall constitute full compensation for furnishing all plant, labor, materials and equipment for work required by this Section.
- B. Temporary Retaining Structures left in place at the direction of the Construction Manager or the Architect/Engineer will be measured and paid for as set forth in Section 012901.

1.03 REFERENCES

- A. The publications listed below form a part of this specification to the extent referenced. The publications are referred to within the text by the basic designation only.
 - 1. Pile Buck International, Inc. (PBI)
PBI-01. (1987) Steel Sheet Pile Design Manual
 - 2. U.S. Army Corps of Engineers (USACE)
EM 385-1-1. (2008) Safety and Health Requirements Manual
 - 3. U.S. Steel Corporation (USS)
USS-01. (1972) Steel Sheet Piling Design Manual
 - 4. Virginia Polytechnic University, Dept. Of Civil Engineering (VT)
VT-01. (1987) An Engineering Manual for Sheet Pile Walls

1.04 RELATED SECTIONS

- A. General Conditions Article 4.7 – Shop Drawings and Other Submittals
- B. Section 014300 - Quality Requirements.

- C. Section 312300 – Excavation and Fill.

1.05 SUBMITTALS

- A. Submit the following in accordance with General Conditions Article 4.7. Submittals signed by the Contractor's (or their Subcontractor's) licensed professional engineer, will be reviewed for content only and not intended for approval by the Architect/Engineer.

- B. Shop Drawings:

- 1. A detailed layout of temporary retaining structures on standard size (22 inches x 34 inches) sheets. These shop drawings shall bear the stamp and signature of the Registered Professional Engineer licensed in the State of New Jersey. These drawings shall clearly show:

- a. All pertinent dimensions and locations of these structures with reference to the project centerline (Wall-line, Baseline, etc.).
- b. Material grade, weight, length and designation of steel sheet pile section(s) used.
- c. Bracing details.
- d. Excavation sequence and procedure.
- e. Provisions made for dewatering, indicating stage of excavation vs. necessary drawdown, water loading conditions, soil loads and equipment loads.
- f. Any other items incidental or significant to this Work.
- g. Equipment Description. Complete hammer, extractors and other installation appurtenances.

- 2. Design Data: Design Calculations

1.06 DESIGN CALCULATIONS

- A. Design Procedures:

- 1. The Contractor shall follow design procedures using the wedge-type method of developing soil pressure for estimating the external forces, set forth in USS-01 excluding the Danish Rules Method published by U.S. Steel Corp.; the PBI-01; or the Free Earth or Fixed Earth methods in the Virginia Tech Dept. of Civil Engineering paper VT-01; or Chapter 4 of the U.S. Army Corps of Engineers Manual EM 1110-2-2504 "Design of Sheet Pile Walls", excluding the Danish

Rules Method. Determination of the effects of surcharge loads on the soil pressures shall be based on the procedures set forth in PBI-01.

2. The design performed by the Contractor must evaluate the overall stability and sizing of the sheet piling and other structural elements for the temporary retaining structures.
3. The Contractor shall submit for approval shop drawings of the proposed design.
4. The Contractor shall use and rely upon the soil borings, design shear strength profile(s) and unit weight data presented in the plans and/or in the figure(s) attached at the end of this section for its design.
5. The structure shall meet all the requirements of EM 385-1-1 for fall protection and ingress and egress.

B. Elevations:

1. The Contractor shall design temporary retaining structure with sufficient height to retain the surrounding soils, and provide for Architect/Engineer's approval, his calculations with pile tip elevations below the bottom of the excavation, and the excavation depth below existing grade.
2. Design shall include determination of the sheet pile tip elevation required for cut-off of recharge of strata having excess hydrostatic water levels. As a minimum this tip elevation shall be provided regardless of that computed in overturning computation.

C. Sheet Pile Wall Design:

1. The design of the sheet pile wall shall be developed using a method of analysis indicated in paragraph "Design Procedures," with the safety factor applied to the soil strengths on both sides of the wall, such as a free earth or fixed earth method.
2. The soil properties used shall be those presented in the drawings and found in the Geotechnical Report which is available to the Contractor but not part of this Contract.

D. Loads:

1. The minimum safety factor used in the geotechnical design for the determination of overturning tip elevation and sheet pile section modulus is 1.30 in the short term (Q) case analysis and 1.0 for the long term (S) shear strength cases.

2. For design of the sheet pile wall the water conditions outside the excavation shall be assumed to be at the existing ground surface, while the water inside the temporary retaining structure excavation is in the drawn-down condition.
 3. The design shall also include the loading influence of any equipment that may be operated adjacent to the temporary retaining structure.
- E. Design of Anchors and Deadmen: In the design of anchors and deadmen the designer shall develop a minimum safety factor of 2.0 for the soil resistance against pull out.
- F. Retaining Wall Members:
1. The structural design of the temporary retaining structure excluding the sheet pile shall be designed using industry standards.
 2. The earth pressures for the structural design of these wall members shall be based upon a wedge-type method applying a safety factor chosen by the designer which shall be no lower than 1.0.
- G. Arch Web "U" Piles:
1. Use of arch web "U" piles shall not be used.
- H. Designs and Modifications:
1. All designs and any subsequent modifications to the design presented above shall be performed, certified and stamped by a Registered Professional Engineer in New Jersey and submitted to the Construction Manager for review and approval. The Registered Professional Engineer shall be present at the Contractor Quality Control preparatory and initial inspections.
 2. The Contractor shall, as a part of the Quality Control, furnish a signed statement by the design Professional Engineer stating that the installation is in conformance with the approved design.
- I. Engineering Analysis and Calculations:
1. If the Contractor's construction plan, sequence and/or methods require the use of the existing structures for any purpose, he shall perform engineering analysis and calculations to ascertain that the purpose for which he intends to use the existing structure will not jeopardize the structural integrity of the same or any part, component, or portion thereof.
 2. Any damages, direct or indirect, caused to that property and to the property of others due to Contractor's failure to comply with this requirement or negligence in calculations shall be the sole responsibility of the Contractor.

1.07 QUALITY CONTROL

- A. The Contractor shall establish and maintain quality control for all operations to assure compliance with contract specifications and maintain records of its quality control for all construction operations, including but not limited to the following:
1. Designing.
 2. Materials (type, strength, etc.).
 3. Fabrication, installation and workmanship.
 4. Full and proper engagement of interlock (inspection and strength).
 5. Placing (location, alignment, etc.).
 6. Driving (pile hammer and rate of operation).
 7. Cutting.
 8. Welding.
 9. Final sheet pile position; depth of penetration; tip and top elevations.
 10. Stockpiling and Storage.
 11. Removal and disposal of damaged piles.
- B. Reporting: The original and two (2) copies of these records and tests, as well as the corrective action taken, shall be furnished to the Construction Manager daily. Format of the report shall be as prescribed in Section 014300.

1.08 DELIVERY, STORAGE AND HANDLING OF MATERIALS

- A. Materials delivered to the site shall be undamaged and shall be accompanied by certified test reports. Sheet piling shall be stored and handled in the manner recommended by the manufacturer to prevent permanent deflection, distortion or damage to the interlocks. Storage of sheet piling should also facilitate inspection.

PART 2 PRODUCTS

2.01 SHEET PILING

- A. The sheet pile shall be hot rolled sheet pile.

PART 3 EXECUTION

3.01 INSTALLATION

- A. **Placing:** Suitable temporary wales, templates, guide structures, or other approved methods shall be provided to ensure that the piles are placed and driven to the correct alignment as shown on the Contractor's shop drawings. Piles shall be placed with each pile interlocked with adjoining piles for its entire length, so as to form a continuous diaphragm throughout the length of each run of piling wall. Interlocks shall be properly engaged. The Contractor's personnel shall not sit or place themselves on top of the sheet piling during the handling, installation, and removal of the piling.
- B. **Driving:** All sheet piles shall be driven to the depths shown on the Contractor' shop drawings using the non-impact, non-vibratory press-in driving method. Pilings shall be driven by approved methods so as not to subject the pilings to damage and to insure proper interlocking throughout their lengths. Pilings damaged during driving or driven out of interlock shall be removed and replaced. All piles shall be driven without the aid of a water jet, unless otherwise authorized. Unless specifically indicated otherwise, each run of piling wall shall be driven to grade progressively from the start and pilings in each run shall be driven alternately in increments of depth to the required depth or elevation. On each day of sheet pile driving, the Contractor shall stab only the number of piles that can be driven to grade by the end of the day, and all piling stabbed shall be driven to grade by the end of each working day except that the last two piles may remain tapered up to receive the next day's piles. If the piling next to the one being driven tends to follow below final grade, it may be pinned to the next adjacent piling. The Contractor is advised that buried stumps or similar debris may be encountered periodically on the sheet pile wall alignment and appropriate consideration should be given to hard driving conditions should they occur. Piles shall not be driven within 100 feet of concrete less than seven (7) days old or within 30 feet of concrete less than 28 days old.
- C. **Emergency Locking System on Pile Driving Head:** All pile driving equipment shall be equipped so as to prevent piles from falling when a single or multiple power failure occurs after the pile driving head is attached to the pile.
- D. **Inspection of Driven Piling:** The Contractor shall inspect the interlocked joints of driven pilings extending above ground. Pilings found to be damaged or driven out of interlock shall be removed and replaced.
- E. **Void Backfill:** Where voids adjacent to the steel sheet piling are induced by pile driving operations, the Contractor shall pump out all seepage and rainwater and backfill with a tremie-placed slurry. The slurry shall consist of one-part cement, two parts bentonite, and six parts sand mixed with enough water to produce a slurry viscous enough to thoroughly fill the voids.

3.02 REMOVAL OF MATERIAL

- A. Removal Criteria: The temporary retaining structures shall not be removed until suitable backfill, between the finished structure and the steel sheet pile wall of the temporary retaining structures is satisfactorily placed and compacted to an elevation approximately one (1) foot below the finished surface. Piles shall not be pulled within 100-feet of concrete less than seven (7) days old nor within 30 feet of concrete less than 28 days old. Nor shall the temporary retaining structures be removed until the completed permanent structure and/or excavations are re-watered. Where voids are induced by removal operations, the Contractor shall pump out all seepage and rainwater and backfill to within 3 feet of the ground surface with a tremie-placed slurry. The slurry shall consist of one-part cement, two parts bentonite and six parts sand mixed with enough water to produce a slurry viscous enough to thoroughly fill the voids but have no less than 12 pounds of solids per gallon. The upper 3 feet shall be filled with suitable backfill. Suitable backfill and compaction requirements shall be as defined in Section 312300. All Contractor-furnished temporary retaining structures shall be removed from the site of work upon completion of work.

3.03 SAFETY

- A. The removal of the temporary retaining structures shall be accomplished in a manner not injurious to the properties adjacent to and in the proximity of the Project excavations.

END OF SECTION 015300

NO TEXT ON THIS PAGE

SECTION 015639 –TEMPORARY TREE PROTECTION

PART 1 - GENERAL

1.01 DESCRIPTION

- A. This Section includes the protection and trimming of trees that are to remain, interfere with, or are affected by, execution of the Work, whether temporary or new construction.

1.02 PAYMENT

- A. No separate payment shall be made for performing any Work required under this Section unless noted otherwise. All costs for Work required by this Section shall be included in the applicable lump sum(s), unit price(s), or allowance(s) as set forth in Section 012901.

1.03 REFERENCES

- A. Nomenclature shall comply with the latest editions of:
 - 1. Standardized Plant Names of the American Joint Committee on Horticulture Nomenclature.
 - 2. Hortus Third, Bailey Hortorium, Cornell Owner (1976).
- B. Sizing and grading shall comply with:
 - 1. “US Standards for Nursery Stock”, 2004, American Association of Nurserymen.
- C. Existing tree value appraisal shall comply with Council of Tree and Landscape Appraisers:
 - 2. Manual for Plant Appraisers Handbook.
 - 3. Guide for Establishing Values of Trees and Other Plants.
- D. Pruning standards: ANSI Z1333.1 – 1972, Safety Requirements for Tree Pruning, Trimming, Repairing or Removal.
- E. Tree Care Standards: ANSI A300 Standards for Tree Care Operations

1.04 RELATED SECTIONS

- A. General Conditions Article 4.7 – Shop Drawings and Other Submittals.
- B. Section 012901 – Measurement and Payment.

- C. Section 014300 - Quality Requirements.
- D. Section 016100 - Control of Materials.
- E. Section 017700 - Contract Closeout.

1.05 REQUIREMENTS OF REGULATORY AGENCIES

- A. Perform work in accordance with all applicable laws, codes, and regulations required by authorities having jurisdiction over such work and provide for all inspections and permits required by Federal, State and local authorities in furnishing, transporting and installing materials.

1.06 DEFINITIONS

- A. Drip line: The outer extent of the canopy projected vertically onto the ground but not less than a radius of 8 foot.

1.07 SUBMITTALS

- A. Submit the following in accordance with General Conditions Article 4.7.
- B. Product Data: For each type of product indicated.
- C. Examination Report: Prior to site work submit an examination report outlining the existing condition of the trees to be protected. Include photographs of each tree:
 - 1. The Contractor shall include as part of the plant examination report submittal a package for trees to be retained and protected. Submittal is to clearly identify the source, sizes of trees including photographs of each tree type (with a person and yard stick for scale purposes). Accompanying each photograph of each tree shall be the following:
 - a. Name of the Project & Owner
 - b. Date photograph was taken
 - c. Species name and number
- D. Qualification Data: For firms and persons specified in paragraph 1.08 - Quality Assurance to demonstrate their capabilities and experience. Include lists of completed projects with project names and addresses, names and addresses of Landscape Architects and owners, and other information specified.
- E. Certification: From a qualified arborist that trees indicated to remain have been protected during construction according to recognized standards and that trees were promptly and properly treated and repaired when damaged.

- F. Maintenance Recommendations: From a qualified arborist for care and protection of trees affected by construction during and after completing the Work.

1.08 QUALITY ASSURANCE

- A. Comply with the requirements specified in Section 014300.
- B. Tree Service Qualifications: An experienced tree service firm that has successfully completed tree protection and trimming work similar to that required for this Project and that will assign an experienced, qualified arborist to Project site on a full-time basis during execution of the Work.
- C. Arborist Qualifications: An arborist certified by the International Society of Arboriculture or licensed in the jurisdiction where Project is located.
- D. Pre-installation Conference: Conduct conference at Project site to comply with requirements.
 - 1. Before starting tree protection and trimming, meet with representatives of authorities having jurisdiction, DEP, Construction Manager, Architect/Engineer, consultants, and other concerned entities. Review tree protection and trimming procedures and responsibilities. Notify participants at least three working days before convening conference. Record discussions and agreements and furnish a copy to each participant.

1.09 DISPOSAL OF WASTE MATERIALS

- A. Burning is not permitted.
- B. Disposal: Remove excess excavated material, displaced trees, and excess chips from Owner's property.

PART 2 - PRODUCTS

2.01 MATERIALS

- A. Fencing: Orange plastic safety mesh, metal “T” bar stakes with tie wires, hog ring ties, and other accessories for a complete fence system.
- B. Water: Potable.
- C. Mulch: Chipped tree trimming waste if free of pests and diseases and growth-inhibiting chemicals.

PART 3 - EXECUTION

3.01 EXAMINATION

- A. Prior to any on site construction work, examine, record and report on the condition of the existing trees. The submitted report shall be used as a basis to assess any future damage.

3.02 PREPARATION

- A. Install temporary fencing located as indicated or outside the drip line of trees to protect remaining vegetation from construction damage. Fencing may be removed to accommodate necessary work within the drip line but shall be reinstalled at the end of each day until the works are complete. Remove fence upon completion.
- B. Protect tree root systems from damage due to noxious materials caused by runoff or spillage while mixing, placing, or storing construction materials. Protect root systems from flooding, eroding, or excessive wetting caused by dewatering operations.
- C. Do not store construction materials, debris, or excavated material within the drip line of remaining trees. Do not permit vehicles or foot traffic within the drip line; prevent soil compaction over root systems. Do not discharge hot exhaust close to foliage.
- D. Do not allow fires under or adjacent to remaining trees or other plants.

3.03 EXCAVATION

- A. Install shoring or other protective support systems to minimize sloping or benching of excavations.
- B. Do not excavate within drip line of trees, unless otherwise indicated.
- C. Where excavation for new construction is required adjacent to existing trees vary excavation methods to protect the root systems:
 - 1. Within 5 foot of trunk no excavation is permitted: Tunnel under roots by drilling, auger boring or pipe jacking.
 - 2. Outside 5 foot of trunk but inside drip line: Excavate by high-pressure water jet on one side of the tree only to leave the root system intact. Relocate roots in backfill areas where possible. If encountering large, main lateral roots, expose roots beyond excavation limits as required to bend and relocate them without breaking. Do not allow exposed roots to dry out before placing permanent backfill. Provide temporary earth cover or pack with peat moss and wrap with burlap. Water and maintain in a moist condition. Temporarily support and protect roots from damage until they are permanently relocated and covered with soil.
 - 3. Outside drip line but inside the radius equal to the height of the tree: Machine excavation is permitted on a maximum of two sides of the tree if at least 6 inches

of the trench wall is hand dug and the roots cut with sharp clean pruning instruments. Do not cut main lateral roots or taproots.

3.04 TREE PRUNING

- A. After verifying extent of pruning with Landscape Architect, execute Maintenance Pruning including Crown Cleaning and Crown Raising as defined by ANSI A300.
- B. Pruning Standards: Prune trees according to ANSI A300.
- C. Chip branches removed from trees. Spread chips where indicated or as directed by Landscape Architect.
- D. Provide subsequent maintenance during Contract period as recommended by qualified arborist.

3.05 TREE REPAIR AND REPLACEMENT

- A. Be responsible for all damage from works under this contract and all damage from works by others if trees were not protected as documented. The contractor shall not be responsible for damage by others if the trees were protected as documented.
- B. For minor repairable damage: Promptly repair trees within 24 hours. Treat damaged trunks, limbs, and roots according to written instructions of the qualified arborist. For compacted soil:
 - 1. Aerate surface soil 10 feet (3 m) beyond drip line and no closer than 36 inches (900 mm) to tree trunk. Drill 2-inch- (50-mm-) diameter holes a minimum of 12 inches (300 mm) deep at 24 inches (600 mm) o.c. Backfill holes with an equal mix of augered soil and sand.
- C. For major damage and/or death of trees under 6-inch caliper (measured 6 inches (150 mm) above grade):
 - 1. Remove and replace with new trees of the same size and species as those being replaced; plant and maintain as directed by the Landscape Architect.
- D. For major damage and/or death of trees over 6-inch caliper (measured 12 inches (300 mm) above grade):
 - 1. Remove and replace with new trees of 6-inch (150-mm) caliper size and of a species selected by the Landscape Architect.
 - 2. For trees between 6-inch and 12-inch caliper, compensate the DEP at a rate of \$250 per inch of caliper.
 - 3. For trees between 12-inch and 18-inch caliper, compensate the DEP at a rate of \$350 per inch of caliper.

4. For trees over 18-inch caliper, compensate the DEP at a rate of \$450 per inch of caliper.

3.06 CONTRACT CLOSEOUT

- A. Provide in accordance with Section 017700.

END OF SECTION 015639

SECTION 015713 - EROSION CONTROL, SEDIMENTATION, AND
CONTAINMENT OF CONSTRUCTION MATERIALS

PART 1 - GENERAL

1.01 DESCRIPTION

- A. Provide all work and take all measures necessary to control soil erosion resulting from construction operations, prevent flow of sediment from construction site, and contain construction materials (including excavation and backfill) within protected working area as to prevent damage to any stream or wetlands.
- B. Section includes:
 - 1. Bales.
 - 2. Silt Fence.
 - 3. Caution Fence.
 - 4. Inlet Filters.
 - 5. Tree Protection During Construction.
 - 6. Construction Driveway.
 - 7. Concrete Washout Facility.
 - 8. Cove Park Sediment Basin
 - 9. Oil-only Emergency Spill Kit.

1.02 PAYMENT

- A. No separate payment shall be made for performing any Work required under this Section unless noted otherwise. All costs for Work required by this Section shall be included in the applicable lump sum(s), unit price(s), or allowance(s) as set forth in Section 012901.

1.03 REFERENCES

- A. Hudson-Essex-Passaic Soil Conservation District (HEPSCD):
 - 1. HEPSCD Soil Erosion & Sediment Control Notes and Application Forms, etc.
- B. New Jersey Department of Agriculture (NJDA):
 - 1. The Standards for Soil Erosion and Sediment Control in New Jersey, current edition.

- C. New Jersey Department of Environmental Protection (NJDEP):
 - 1. New Jersey Stormwater Best Management Practices Manual, current edition.
- D. New Jersey Department of Transportation (NJDOT):
 - 1. Standard Specifications for Road and Bridge Construction, current edition.
- E. United States Environmental Protection Agency (USEPA):
 - 1. Guidelines for Erosion and Sediment Control, Planning and Implementation.
 - 2. Processes, Procedures and Methods to Control Pollution Resulting from all Construction Activity.
- F. American Association of State Highway and Transportation Officials (AASHTO):
 - 1. M288: Standard Specification for Geosynthetic Specification for Highway Applications
- G. American Society of Testing Materials (ASTM):
 - 1. ASTM D 3786: Bursting Strength
 - 2. ASTM D 648: Standard Test Method for Deflection Temperature of Plastics Under Flexural Load in the Edgewise Position
- H. United States General Services Administration
 - 1. FED-STD-595B: Federal Standard 595B – Colors Used in Government Procurement

1.04 RELATED SECTIONS

- A. General Conditions Article 4.7 – Shop Drawings and Other Submittals.
- B. Section 014300 – Quality Requirements.
- C. Section 021600 - Excess Clean Fill, Contaminated Soil, and Groundwater Management and Disposal.

1.05 SUBMITTALS

- A. Submit the following items in accordance with General Conditions Article 4.7
 - 1. At least 10 days before the first concrete placement, the Contractor shall submit to the Construction Manager for approval a plan for the concrete washout system.

Design the concrete washout system to fully contain the concrete washout needs, concrete slurry, and the concrete testing of the Work.

2. Silt Fence
3. Inlet Protection

1.06 PERMITS BY THE CONTRACTOR

- A. In addition to the work permits required to be obtained by the Contractor, the following permits are also required:
 1. Contractor is required to apply for SESC plan approval from the Hudson-Essex-Passaic Soil Conservation District for any staging area, office trailer locations and other contractor managed areas. SESC plan approval for the project work has been obtained by the NJDEP. Provide all information needed by the HEPCSD for their review and approval.
 2. Contractor will also apply for the NJPDES Stormwater General Permit for Construction Activities (5G3 permit).

1.07 QUALITY ASSURANCE

- A. Comply with the requirements under Section 014300
- B. Use acceptable procedures, including use of water diversion structures, diversion ditches, settling basins, and sediment traps.
- C. Operations restricted to areas of work indicated on drawings and area which must be entered for construction of temporary or permanent facilities.
- D. Before start of construction operations, place oil-only emergency spill kits within the Project Limits.
- E. If construction materials are washed away during construction, remove materials from fouled areas.
- F. Stabilize diversion outlets by means acceptable to Construction Manager.
- G. Construction Manager has authority to limit surface area of erodible earth material exposed by clearing and grubbing, excavation, borrow and fill operations and to direct immediate permanent or temporary pollution control measures to prevent contamination of any stream or wetlands, including construction of temporary berms, dikes, dams, sediment basins, sediment traps, slope drains, and use of temporary mulches, mats, or other control devices or methods to control erosion.

PART 2 - PRODUCTS

2.01 BALES

- A. Straw or other suitable material acceptable to Construction Manager.

2.02 WOOD STAKES

- A. For silt fence and bales, 2 inches by 2 inches by 3 feet. For heavy-duty silt fence, 4 inches by 4 inches by 5 feet. A 2-inch diameter galvanized chain-link fence post may be substituted for the heavy-duty silt fence wood stake.

2.03 SILT FENCE

- A. Provide geotextiles that meet the requirements of AASHTO M288. Reinforce heavy duty silt fence with wire mesh. Wire mesh shall be 15-gauge welded steel wire mesh, with 4-inch square openings.

2.04 CAUTION FENCE

- A. Fabricate the fabric for plastic caution fence from HDPE with a minimum tensile strength of 5000 pounds per square inch when tested according to ASTM D 648. Use fabric that is blaze orange in color that matches FED-STD-595B color chip No. 38915 and is ultraviolet stabilized.
- B. Use posts made of high carbon steel with a flanged leg channel section or flanged leg U-bar section having a uniform thickness of metal of not less than 1/8 inch. Ensure that the posts weigh at least two (2) pounds per linear foot, exclusive of ground plate, and are designed to be easily driven into the ground. Equip each post with at least 11 riveted lugs. Do not equip posts with punched or welded lugs. Galvanize posts.

2.05 COARSE AGGREGATE

- A. Obtain coarse aggregate as specified in NJDOT Standard Specifications Section 901.03. Use coarse aggregate that is broken stone or washed gravel graded as specified NJDOT Standard Specifications Table 901.03-1.

2.06 INLET PROTECTION

- A. Provide geotextiles that meet the requirements of AASHTO M288. For inlet filters, use Class 2 for woven monofilament geotextiles or Class 1 for all other types of geotextiles. For inlet filter, Type 2, in addition to the AASHTO M 288 requirements, ensure that the geotextile's burst strength is at least 650 pounds per square inch when tested according to ASTM D 3786.

2.07 SEDIMENT BASIN – COVE PARK

- A. Provide Cove Park sediment basin as detailed on the Plans

2.08 OIL-ONLY EMERGENCY SPILL KIT

- A. Each oil-only emergency spill kit shall be capable of cleaning up at least 95 gallons of spill. Provide Oil-Only Emergency Spill Ki that consists of the following:
 - 1. An instruction manual and emergency response guide.
 - 2. Ten 5-inch × 10-foot oil-only absorbent booms.
 - 3. Ten 3-inch × 10-foot oil-only absorbent booms.
 - 4. One hundred 20 × 16-inch oil-only absorbent pads.
 - 5. Twenty temporary disposal bags and ties.
 - 6. A 40-pound bag of loose absorbent pellets.
 - 7. A wheeled container for the above.

PART 3 - EXECUTION

3.01 GENERAL

- A. Do not discharge chemicals, fuels, lubricants, bitumen, raw sewage, and other harmful waste into or alongside any body of water or into natural or man-made channels.
- B. If a spill occurs, immediately contain the spill and notify the NJDEP Hotline (1-877-927-6337), the Construction Manager. Clean up and remediate the spill as directed by the DEP. Separately stockpile, as specified in Section 021600, the contaminated material and dispose of the contaminated material. Submit an incident report to the Construction Manager within five (5) days after clean-up that includes a summary of the incident, the clean-up and containment measures taken, the time and date of the incident, and the NJDEP case number.
- C. Replenish the kits to ensure that the specified number of complete kits is on-site at all times during construction operations.
- D. Design erosion and sediment controls to handle peak runoff resulting from storm events.
- E. The Contractor shall be responsible for inspecting and maintaining these control measures to ensure their proper function and adequate sediment storage at all times. The Contractor shall remove sediment once it reaches 50 percent of the capacity of the structure. Sediment collected shall be disposed of offsite at the Contractor's cost.

3.02 INSTALLATION

- A. Install baled straw erosion checks, silt fence, heavy-duty silt fence, and inlet protection in all locations as directed, surrounding base of all deposits of stored excavated material outside of disturbed area, and where directed by the Construction Manager.
- B. Install checks immediately after site is cleared and before trench excavation. Locate checks, surrounding stored material, approximately 6 feet from material.
- C. Hold bales in place with two (2) 2 inch by 2 inch by 3 feet stakes so that each bale is butted tightly against adjoining bale thereby precluding short-circuiting of erosion check.
- D. Place stakes for silt fence along the line shown on the plans. Hold silt fence in place with 2 inch by 2 inch by 3 feet stakes. For heavy-duty silt fence, use stakes measuring 4 inch by 4 inch by 5 feet or 2 inch diameter galvanized chain-link fence posts.
- E. Install inlet filters where shown on the plans and in accordance with the manufacturer's instructions.
- F. Install a stabilized construction driveway at all points of construction ingress and egress where sediment may be tracked, or flow off, the construction site. Construct driveways using No. 2 coarse aggregate placed on geotextile. Ensure that the driveway is at least 15 feet wide. The Contractor may make driveways wider if approved by the Construction Manager. Maintain the driveway by top dressing or by excavating and top dressing, as directed by the Construction Manager, with additional No. 2 coarse aggregate. When the driveway is no longer required, remove the driveway, backfill to the adjacent ground elevation, and restore the disturbed area to the original condition.
- G. Install concrete washout facilities to prevent discharge from concrete trucks and equipment cleaning from entering into inlets and into surface or groundwater. Ensure that the locations of concrete washout facilities are no closer than 50 feet from environmentally sensitive areas such as streams, wetlands, or other areas shown on the Plans. Use signs to designate concrete washout areas. Ensure that concrete washout facilities are limited to the designated areas.
 - 1. The concrete washout system must be in place before delivery of concrete to the site. Ensure that a secure, non-collapsing, non-water collecting cover over each concrete washout facility is in place during precipitation so that precipitation does not accumulate and cause the washout areas to overflow. If the concrete washout facility becomes 50 percent full, discontinue pouring concrete until the concrete washout facility is cleaned out. Allow slurry to evaporate, or dispose of, as specified in Section 021600.
 - 2. If a lined basin is used, replace the liner if it becomes damaged or compromised. Remove concrete washout facilities when no longer needed. Restore the disturbed area to original condition.

- H. Construct earth berms or diversions to intercept and divert runoff water from critical areas.
- I. Discharge silt-laden water from excavations onto filter fabric mat and/or baled straw sediment traps to ensure that only sediment-free water is returned to watercourses.
- J. Do not place excavated soil material adjacent to water-course in manner that will cause it to wash away by high water or runoff.
- K. Prevent damage to vegetation by excessive watering or silt accumulation in the discharge area.
- L. Do not dump spoiled material into any streams, wetlands, surface waters, or unspecified locations.
- M. Prevent indiscriminate, arbitrary, or capricious operation of equipment in streams, wetlands, or surface waters.
- N. Do not pump silt-laden water from trenches or excavations into surface waters, streams, wetlands, or natural or man-made channels leading thereto.
- O. Prevent damage to vegetation adjacent to or outside of construction area limits by surrounding the vegetation with fencing or other barrier installed at the drip line of the tree branches.
- P. Do not dispose of trees, brush, debris, paints, chemicals, asphalt products, concrete curing compounds, fuels, lubricants, insecticides, wash water from concrete trucks or hydroseeders, or any other pollutant in streams, wet-lands, surface waters, or natural or man-made channels leading thereto, or unspecified locations.
- Q. Do not alter flow line of any stream unless indicated or specified.
- R. Remove temporary soil erosion and sediment control (SESC) measures when necessary to allow for the installation of permanent measures, or as permanent measures become functional. Notify the Construction Manager 10 days before removing temporary SESC measures. Do not remove temporary SESC measures until the Construction Manager determines which, if any, specific Items must remain in place.

END OF SECTION 015713

NO TEXT ON THIS PAGE

SECTION 016100 - CONTROL OF MATERIALS

PART 1 - GENERAL

1.01 DESCRIPTION

- A. This Section includes administrative and procedural requirements for selection of products for use in Project; product delivery, storage, and handling; manufacturers' standard warranties on products; special warranties; and comparable products.

1. Section Includes:

- a. Definitions.
- b. Submittals.
- c. Spare parts.
- d. Quality assurance.
- e. Delivery, storage, and handling.
- f. Warranty.
- g. Products.
- h. Substitution and "Or Equal" items.
- i. Reuse of existing material.
- j. Manufacturer's instructions.
- k. Special tools.
- l. Lubrication.
- m. Nameplates.
- n. Loads and seismic forces.
- o. General material and equipment requirements.
- p. Materials and Equipment.
- q. Field Quality Control; Installation, Instructional, and Post Startup Services.

1.02 PAYMENT

- A. No separate payment shall be made for performing any Work required under this Section. All costs for Work required by this Section shall be included in the applicable lump sum(s), unit price(s), or allowance(s) as set forth in Section 012901.

1.03 REFERENCES

- A. American Society of Mechanical Engineers (ASME):
 - 1. B1.1: Unified Inch Screw Threads (UN and UNR Thread Form)
- B. American Society for Testing and Materials International (ASTM):
 - 1. A123/A123M: Standard Specification for Zinc (Hot-Dip Galvanized) Coatings on Iron and Steel Products
 - 2. A252: Standard Specification for Welded and Seamless Steel Pipe Piles
 - 3. A325/A325M: Standard Specification for Structural Bolts, Steel, Heat Treated, 120/105 ksi Minimum Tensile Strength

1.04 RELATED SECTIONS

- A. General Conditions Article 4.7 – Shop Drawings and Other Submittals.
- B. General Conditions Article 4.11 – Equipment and Materials.
- C. General Conditions Article 8 – Close-out.
- D. Section 012901 – Measurement and Payment.
- E. Section 014300 - Quality Requirements.
- F. Section 017700 - Contract Closeout.

1.05 DEFINITIONS

- A. Products: Items obtained for incorporating into the Work, whether purchased for Project or taken from previously purchased stock. The term "product" includes the terms "material," "equipment," "system," and terms of similar intent.
 - 1. Named Products: Items identified by manufacturer's product name, including make or model number or other designation shown or listed in manufacturer's published product literature, that is current as of date of the Contract Documents.

2. New Products: Items that have not previously been incorporated into another project or facility. Products salvaged or recycled from other projects are not considered new products.
3. Comparable Product: Product that is demonstrated and accepted through submittal process to have the indicated qualities related to type, function, dimension, in-service performance, physical properties, appearance, and other characteristics that equal or exceed those of specified product.

1.06 SUBMITTALS

- A. Comparable Product Requests: Submit request for consideration of each comparable product. Identify product or fabrication or installation method to be replaced. Include Contract Section number and title and Drawing numbers and titles.
 1. Comply with the requirements of General Conditions Article 4.7.
 2. Include data to indicate compliance with the requirements specified in General Conditions Article 4.7.

1.07 SPARE PARTS

- A. Provide spare parts for Products as specified in the individual technical specification sections. Comply with the requirements specified in this Section.
- B. Pack spare parts to protect them during storage. Tag spare parts and containers to clearly identify them in accordance with Contractor's parts numbering system as reviewed by the Construction Manager. All parts shall be cross-referenced to their applicable the Contract Section.

1.08 QUALITY ASSURANCE

- A. Comply with the requirements specified in Section 014300.
- B. Compatibility of Options: If Contractor is given option of selecting between two (2) or more products for use on Project, select product compatible with products previously selected, even if previously selected products were also options.

1.09 DELIVERY, STORAGE AND HANDLING

- A. Contractor shall arrange deliveries of materials and equipment in accordance with construction Progress Schedule, coordinate to avoid conflict with Work and conditions at site.
- B. Comply with the requirements of General Conditions Article 4.11.

- C. Provide equipment and personnel to handle materials and equipment by methods recommended by manufacturer to prevent soiling or damage to materials or equipment, or their packaging.
- D. Deliver, store, and handle products using means and methods that will prevent damage, deterioration, and loss, including theft and vandalism. Comply with manufacturer's written instructions.
- E. NJDEP assumes no responsibility for damage or loss due to storage of materials and equipment.
- F. Interior Storage:
 - 1. Store with seals and labels intact and legible.
 - 2. Store materials and equipment subject to damage by elements in weathertight enclosures.
 - 3. Maintain temperature and humidity within ranges required by manufacturer's instructions.
- G. Exterior Storage:
 - 1. Store fabricated materials and equipment above ground, on blocking or skids, to prevent soiling or staining. Cover materials and equipment subject to deterioration with impervious sheet coverings. Provide ventilation to avoid condensation.
 - 2. Store loose granular materials in well drained area on solid surfaces to prevent mixing with foreign matter.
 - 3. Store materials such as pipe, reinforcing steel, structural steel, and equipment on pallets or racks, off ground.
- H. Inspection and Maintenance:
 - 1. Arrange storage to provide easy access for inspection, maintenance, and inventory.
 - 2. Make periodic inspections of stored materials and equipment to ensure materials and equipment maintained under specified conditions are free from damage or deterioration, and coverings are in place and in condition to provide required protection.
 - 3. Perform maintenance on stored material and equipment in accordance with manufacturer's written instructions and in presence of NJDEP or Construction Manager.

- a. Notify Construction Manager twenty-four (24) hours before performance of maintenance.
 - b. Submit report of completed maintenance and condition of coverings to Construction Manager with each Application for Payment.
 - c. Failure to perform maintenance, to notify Construction Manager of intent to perform maintenance, or to submit maintenance report may result in rejection of material or equipment.
- I. Contractor shall assume responsibility for protection of completed construction and repair and restore damage to completed Work equal to original condition.
 - J. Where structural concrete is also finished surface, avoid marking or damaging surface.
- 1.10 WARRANTY
- A. Refer to General Conditions Article 8.4.
 - B. Warranties specified in other Sections shall be in addition to, and run concurrent with, other warranties required by the Contract Documents. Manufacturer's disclaimers and limitations on product warranties do not relieve Contractor of obligations under requirements of the Contract Documents.
 - 1. Manufacturer's Warranty: Written warranty furnished by individual manufacturer for a particular product and specifically endorsed by manufacturer to NJDEP.
- 1.11 PRODUCTS
- A. Furnish products of qualified manufacturers suitable for intended use. Furnish products of each type by single manufacturer unless specified otherwise.
 - B. Do not use materials and equipment removed from existing premises, except as specifically permitted by Contract Documents.
 - C. Furnish interchangeable components from same manufacturer for components being replaced.
- 1.12 SUBSTITUTION AND “OR EQUAL” ITEMS
- A. Follow the procedures in General Conditions Article 4.7.
- 1.13 ACCEPTANCE OF MATERIALS
- A. Unless otherwise specified, only new materials and equipment shall be incorporated in the work. All materials and equipment furnished by the Contractor shall be subject to the

inspection and acceptance of the Construction Manager. No material shall be delivered to the work without prior acceptance of the Construction Manager.

- B. As specified in General Conditions 4.7, the Contractor shall submit to the Construction Manager, data relating to materials and equipment he proposes to furnish for the work. Such data shall be in sufficient detail to enable the Construction Manager to identify the particular product and to form an opinion as to its conformity to the specifications.
- C. Facilities and labor for handling and inspection of all materials and equipment shall be furnished by the Contractor. If the Construction Manager requires, either prior to beginning or during the progress of the work, the Contractor shall submit additional samples or materials for such special tests as may be necessary to demonstrate that they conform to the specifications. Such samples shall be furnished, stored, packed, and shipped at the Contractor's expense.
- D. Any delay of acceptance resulting from the Contractor's failure to submit samples or data promptly shall not be used as a basis of a claim against the NJDEP or the Construction Manager.
- E. In order to demonstrate the proficiency of workmen or to facilitate the choice among several textures, types, finishes, and surfaces, the Contractor shall provide such samples of workmanship or finish as may be required.
- F. The materials and equipment used on the work shall correspond to the accepted samples or other data.

1.14 REUSE OF EXISTING MATERIAL

- A. Except as specifically indicated or specified, do not use materials and equipment removed from existing structure(s) in new Work.

1.15 MANUFACTURER'S INSTRUCTIONS

- A. Installation of equipment and materials shall comply with manufacturer's instructions. Obtain and distribute printed copies of such instructions to parties involved in installation, including two (2) copies to Construction Manager.
 - 1. Maintain one (1) set of complete instructions at Site during installation and until completion of Work.
- B. Handle, store, install, connect, clean, condition, and adjust materials and equipment in accordance with manufacturer's written instructions and in conformance with Contract Sections.

1. If Site conditions or specified requirements conflict with manufacturer's instructions, consult Construction Manager for further instructions. Do not proceed with Work without written instructions.

1.16 SPECIAL TOOLS

- A. For each type of equipment furnished, the Contractor shall provide a complete set of all special tools (including grease guns or other lubricating devices) which may be necessary for the adjustment, operation, maintenance, and disassembly of such equipment. Tools shall be high-grade, smooth, forged, alloy, tool steel. Grease guns shall be lever type.
- B. Special tools are considered to be those tools which because of their limited use are not normally available, but which are necessary for the particular equipment.
- C. Pack items to protect them during storage. Tag items and containers to clearly identify them in accordance with Contractor's part system, as reviewed by the Construction Manager. Cross-reference all items to their applicable Contract Section.
- D. Special tools shall be delivered at the same time as the equipment to which they pertain. The Contractor shall properly store and safeguard such special tools until completion of the work, at which time they shall be delivered to the Construction Manager.
- E. The Contractor shall furnish and erect one or more steel wall cases with flat key locks and clips or hooks to hold each tool in arrangement.

1.17 LUBRICATION

- A. Where lubrication is required for proper operation of equipment, incorporate necessary and proper provisions in equipment in accordance with manufacturer's requirements. Where possible, lubrication shall be automated and positive.
- B. Where oil is used, reservoir shall be of sufficient capacity to supply unit for 24 hour period.
- C. Provide adequate and, as far as practicable, automatic means of lubrication for working parts. Arrange lubrication grease nipples, grease boxes and other lubrication devices so that they are readily accessible for routing greasing using grease nipples and Type 316 stainless steel or copper tubing extensions where required. Secure nipples and tubing to the equipment at appropriate locations. Indicate on the working drawings submitted, the types of lubricants to be used (must be readily available in New Jersey). Use grease nipples of a consistent type, Alemite button head type or equivalent. Provide grease gun(s) of the appropriate size(s) and pressure(s).
- D. Provide a one (1) year supply of all lubricants necessary for the routine, daily operation of the equipment. All lubricants to be readily available New Jersey. Provide a complete schedule of all the lubricant including the manufacturer name, type, name and local

address and phone number of where each lubricant can be purchased for each piece of equipment.

1.18 NAMEPLATES

- A. With the exceptions mentioned below, each piece of equipment shall be provided with a nameplate of non-corrodible metal, securely fastened in place and clearly and permanently inscribed with the manufacturer's name, model or type designation, serial number, principal rated capacities, electrical or other power characteristics, and similar information.
- B. This requirement shall not apply to standard, manually operated hydrants,
- C. Each process valve shall be provided with a substantial tag of non-corrodible metal securely fastened in place and inscribed with an identification number in conformance with the Valve Identification Schedule indicated on the drawings or furnished later by the EOR.

1.19 GENERAL MATERIAL AND EQUIPMENT REQUIREMENTS

- A. The requirements of this Paragraph shall constitute the standards for the material and equipment specified herein. Should these requirements conflict with the Supplier's recommendations or in any way be less stringent than the Supplier's requirements, they shall be superseded by the Supplier's requirements.
- B. Bolts, Anchor Rods and Nuts:
 - 1. All necessary bolts, anchor rods, nuts, washers, plates and bolt sleeves shall be furnished by the contractor in accordance herewith. Anchor rods shall have suitable washers and hexagonal nuts.
 - 2. All anchor rods, nuts, washers, plates, and bolt sleeves shall be stainless steel unless otherwise indicated or specified.
 - 3. Unless otherwise specified, stud, tap, and machine bolts, and nuts shall conform to the requirements of ASTM A325. Hexagonal nuts of the same quality of metal as the bolts shall be used. All threads shall be clean cut and shall conform to ANSI Standard B1.1 for Unified Inch Screw Threads (UN and UNR Thread Form).
 - 4. Bolts, anchor rods, nuts, and washers, specified to be galvanized, shall be zinc coated, after being threaded, by the hot-dip process in conformity with ASTM A123, or ASTM A153, as appropriate.
 - 5. Bolts, anchor rods, nuts, and washers specified to be stainless steel shall be Type 304 or Type 316 stainless steel, as indicated.

6. Anchor rods shall be set accurately. They shall be carefully held in suitable templates of acceptable design. Where indicated on the Drawings, specified, or required, anchor bolts shall be provided with square plates at least 4 in. by 4 in. by 3/8 in. or shall have square heads and washers and set in the concrete forms with suitable pipe sleeves, or both. If anchors are set after the concrete has been placed, all necessary drilling and grouting or caulking shall be done by the Contractor and care shall be taken not to damage the structure or finish by cracking, chipping, spalling, or otherwise during the drilling and caulking.

C. Grease Fittings:

1. Provide extension fittings and tubing on all grease fittings that are installed in an inaccessible location. The extension is to be located so that equipment can be lubricated from the operating level without the use of ladders, staging or shutting down the equipment. Tubing: Type 316 stainless steel.

D. Concrete Inserts For Hangers:

1. Concrete inserts for hangers shall be designed to support safely, in the concrete that is used, the maximum load that can be imposed by the hangers used in the inserts. Inserts for hangers shall be of a type which will permit adjustment of the hangers both horizontally (in one (1) plane) and vertically and locking of the hanger head or nut. All inserts shall be galvanized by the hot-dip process in conformity with ASTM A123, or ASTM A153, as appropriate.

E. Equipment Foundations, Installation and Grouting:

1. The Contractor shall furnish the necessary materials and construct suitable concrete foundations for all equipment installed by him, even though such foundations may not be indicated on the Contract Drawings. The tops of foundations shall be at such elevations as will permit grouting as specified below.
2. All such equipment shall be installed by skilled mechanics and in accordance with the instructions of the manufacturer.
3. In setting pumps, motors, and other items of equipment customarily grouted, the Contractor shall make an allowance of at least one (1) inch for grout under the equipment bases. Shims used to level and adjust the bases shall be steel. Shims may be left embedded in the grout, in which case they shall be installed neatly and so as to be as inconspicuous as possible in the completed work. Unless otherwise permitted, all grouts shall be a suitable non-metallic, non-shrink grout.
4. Grout shall be mixed and placed in accordance with the recommendations of the manufacturer. Where practicable, the grout shall be placed through the grout holes in the base and worked outward and under the edges of the base and across the

rough top of the concrete foundation to a peripheral form so constructed as to provide a suitable chamfer around the top edge of the finished foundation.

5. Where such procedure is impracticable, the method of placing grout shall be as accepted by the Construction Manager. After the grout has hardened sufficiently, all forms, hoppers, and excess grout shall be removed, and all exposed grout surfaces shall be patched in an accepted manner and given a burlap-rubbed finish.

F. Equipment Drive Guards:

1. All equipment driven by open shafts, belts, chains, or gears shall be provided with acceptable all-metal guards enclosing the drive mechanism. Guards shall be constructed of Type 316 Stainless Steel (12 gage minimum), as shown on the Contract Drawings. Guards are to be lockable. Guards shall be secured in position by steel braces or straps which will permit easy removal for servicing the equipment. The guards shall conform in all respects to all applicable safety codes and regulations.
2. Provide pivoting access covers for shaft speed measurements.

G. Sleeves:

1. Unless otherwise indicated on the drawings, or specified, form openings for the passage of pipes, conduits, and circular ducts through slabs and walls using sleeves of standard weight, galvanized-steel pipe according to ASTM A 252 and ASTM A 123. Provide sleeves of ample diameter to pass the pipe and its insulation, if any, and to permit expansion as may occur. Provide sleeves that extend 8 inches past the structure face. Threaded nipples shall not be used as sleeves.
2. Sleeves shall be set accurately before the concrete is placed or shall be built in accurately as the masonry is being built.

H. Protection Against Electrolysis:

1. Where dissimilar metals are used in conjunction with each other, provide insulation between adjoining surfaces to eliminate direct contact and any resultant electrolysis. Provide bituminous insulation, heavy bituminous coatings, non-metallic separators or washers, impregnated felt, or other means to provide insulation.

PART 2 - PRODUCTS

2.01 MATERIALS AND EQUIPMENT

A. Material and Equipment Incorporated into Work:

1. Conform to applicable specifications and standards.
 2. Comply with size, make, type, and quality specified or as accepted by Submittal.
- B. Manufactured and Fabricated Materials and Equipment:
1. Design, fabricate, and assemble in accordance with engineering and shop practices standard with industry.
 2. Manufacture like parts of duplicate units to standard sizes and gauges, to be interchangeable.
 3. Two (2) or more items of same kind shall be identical, by same manufacturer.
 4. Material and equipment shall be suitable for service conditions.
 5. Equipment capabilities, sizes, and dimensions shown or specified shall be adhered to, unless variations are specifically accepted, in writing.
 6. Equipment shall be adapted to best economy in power consumption and maintenance. Parts and components shall be proportioned for stresses occurring during continuous or intermittent operation, and for additional stresses occurring during fabrication or installation.
 7. Design so working parts are readily accessible for inspection and repair, easily duplicated, and replaced.
 8. Design structural members of equipment for anticipated shock and vibratory loads.
 9. Design machinery such that working parts are readily accessible for inspection and repair, and that each part is suitable for the service required.
- C. Do not use material or equipment for purpose other than for which it is designed or specified.

PART 3 - EXECUTION

3.01 FIELD QUALITY CONTROL; INSTALLATION, INSTRUCTIONAL, AND POST STARTUP SERVICES

- A. General:
1. Provide on-site services of Supplier's representatives for equipment provided by Contractor during construction, installation, equipment startup, and training of NJDEP's personnel for equipment or plant operation as specifically required in Specification section for equipment or system.

2. Include and pay costs for Supplier's services.
3. Normal daytime construction activity shall take place only between the hours of 8:00 a.m. to 6:00 p.m., excluding Saturdays, Sundays, and legal holidays. Night construction activity, pending approval from the Municipality, shall take place between the hours of 9:00 p.m. to 5:00 a.m., excluding Saturdays, Sundays, and legal holidays. Work outside the above time periods will be permitted only with the written approval of the appropriate municipalities (County of Hudson, City of Jersey City, City of Hoboken, and Township of Weehawken).
4. Contract Sections include minimum man-days to provide basis for bidding. If additional time is required to perform services Contractor shall include that time in Contract Price.

B. Installation Services:

1. Where installation services are called for in Contract Sections, provide competent and experienced technical representatives of manufacturers of material or equipment and systems to resolve assembly or installation procedures attributable to, or associated with, equipment furnished.
2. After equipment is installed, representatives shall perform initial equipment and system adjustment and calibration to conform to Specifications and manufacturer's requirements and instructions.
3. Provide "Certificate of Installation Services" stating proper adjustments have been made to equipment or system and equipment or system is ready for startup and system demonstration. Use Form 016100-1 and furnish two (2) copies to Construction Manager.

C. Training:

1. Comply General Conditions Article 8.3
2. Do not start training until Installation Services have been completed.
3. Where training is called for in Specifications, provide competent and experienced technical representative of Supplier to provide detailed instructions to NJDEP's personnel for operation of equipment. Training services shall include operation and maintenance of instrumentation and equipment in classroom and on-site. Training shall include electrical, mechanical, and safety aspects of equipment. All training shall be recorded and provided to NJDEP.
4. Submit documentation identifying name of specific representative, factory authorization, and background of named individual(s) to conduct training. Submit

information 30 days before scheduled training period for review and acceptance by Architect/Engineer.

5. Coordinate training periods with Construction Manager and Supplier's representatives.
 - a. No training shall be conducted unless instructor has been accepted by Architect/Engineer.
 - b. Notify Construction Manager at least 48 hours before training sessions are scheduled to begin, so Construction Manager can make arrangements with NJDEP's operating personnel.
 - c. Reschedule canceled training sessions 48 hours in advance.
 - d. Failure of Supplier's or manufacturer's representative to appear for scheduled training, failure to notify Construction Manager 24 hours in advance of need to cancel scheduled training or failure to arrive within 30 min of start of scheduled training shall result in reimbursement to NJDEP for time lost by NJDEP's personnel in waiting for arrival of manufacturer's representative. Except in case of failure to arrive on time, time will not exceed one (1) hour for each employee scheduled to receive training. Failure to arrive on time will be reimbursed by actual time late, up to one (1) hour, after one (1) hour training will be rescheduled.
 - e. Failure of Supplier's or manufacturer's representative to appear for scheduled training, failure to notify Construction Manager 24 hours in advance of need to cancel scheduled training or failure to arrive within 30 minutes of start of scheduled training shall result in reimbursement to NJDEP for expenses and time incurred by Construction Manager in traveling and time spent on-site. Minimum time billed shall be eight (8) hours.
6. Similar types of equipment differing in model, size or manufacturer shall require equal service time as stated in specific Contract Section.
7. O&M data shall constitute basis of instruction.
 - a. Review data contents with personnel in full detail to explain aspects of operations and maintenance.
8. Provide "Certificate of Instructional Services", cosigned by NJDEP and Supplier's representative, verifying training has been accomplished to satisfaction of each party.

D. Post Startup Services:

1. After equipment/system has been in operation for at least 6 months, but no longer than 11 months, each equipment manufacturer or authorized equipment representative shall make final inspection when required in Specifications. Final inspection will provide assistance to NJDEP's operating personnel in making adjustments or calibrations required to ensure equipment or system is operating in conformance with design, manufacturer, and Specifications.
2. Provide "Certificate of Post Startup Services", cosigned by NJDEP and equipment representative, verifying this service has been performed. Use form similar to Form 016100-2 and furnish two (2) copies to Construction Manager.

3.02 CONTRACT CLOSEOUT

- A. Provide in accordance with General Conditions Article 8.
- B. Refer to Section 017700.

FORM 016100-1
EQUIPMENT MANUFACTURER'S CERTIFICATE OF INSTALLATION SERVICES

NJDEP (Owner) - _____

Project - _____
Contract No. _____

AECOM No.

EQUIPMENT SPECIFICATION SECTION _____

EQUIPMENT DESCRIPTION _____

I _____, Authorized representative of
(Print Name)

(Print Manufacturer's Name)

hereby CERTIFY that _____
(Print equipment name and model with serial No.)

conforms to the requirements of the Contract and is ready for permanent operation and that
nothing in the installation will render the manufacturer's warranty null and void.
on

Date: _____ Time: _____

CERTIFIED BY: _____ DATE: _____
(Signature of Manufacturer's Representative)

FORM 016100-2
EQUIPMENT MANUFACTURER'S CERTIFICATE OF POST STARTUP SERVICES

NJDEP (Owner) - _____

Project - _____

Contract No. _____

AECOM No. _____

EQUIPMENT SPECIFICATION SECTION _____

EQUIPMENT DESCRIPTION _____

I _____, Authorized representative of
(Print Name)

(Print Manufacturer's Name)

hereby CERTIFY that _____
(Print equipment name and model with serial No.)

Post Startup Services for the subject project (has) (have) been performed in a satisfactory manner, and that NJDEP assigned operating personnel have been suitably instructed in the operation, lubrication, and care of the unit(s) on

Date: _____ Time: _____

CERTIFIED BY: _____ DATE: _____
(Signature of Manufacturer's Representative)

NJDEP'S ACKNOWLEDGMENT OF POST STARTUP SERVICES

(I) (We) the undersigned, authorized representatives of the NJDEP and/or Plant Operating Personnel have received Post Startup Services for the equipment as required by the contract on:

_____ Date: _____

END OF SECTION 016100

SECTION 017329 - CUTTING, CORING, AND PATCHING

PART 1 - GENERAL

1.01 DESCRIPTION

A. Section includes:

1. Alterations to existing buildings or structures.
2. Cutting, coring, and patching.

B. All cutting, coring, and rough patching shall be performed by the Contractor. Finish patching shall be the responsibility of the Contractor.

C. Work includes:

1. Alterations:

- a. Cutting, moving, or removal of items as shown on Contract Drawings.
- b. Cutting, moving, or removal of items not shown to be cut, moved or removed, but which must be cut, moved or removed to allow new Work to proceed. Patch or reinstall Work or items which are to remain in finished Work after cutting, moving or removal, and make joints and finishes match adjacent or similar Work.
- c. Removal of existing surface finishes as needed to install new Work and finishes.
- d. Removal of abandoned items and removal of items serving no useful purpose, such as piping and electrical conduit.
- e. Repair or removal of dangerous or unsanitary conditions.
- f. Removal of unsuitable or extraneous materials not marked for salvage, such as debris, rotted wood, rusted trench covers, and deteriorated concrete and masonry.

2. Cutting and Patching:

- a. Removal and replacement of defective Work and Work not conforming to Contract Documents.
- b. Uncovering Work to provide observation by Construction Manager or inspection or tests by others of covered Work.

- c. Removal of samples of installed materials for testing.
- d. To make several parts fit properly.

3. Temporary enclosures and services.

1.02 PAYMENT

- A. No separate payment shall be made for performing any Work required under this Section. All costs for Work required by this Section shall be included in the applicable lump sum(s), unit price(s), or allowance(s) as set forth in Section 012901.

1.03 REFERENCES

- A. American Society for Testing and Materials International (ASTM):
 - 1. E84: Standard Test Method for Surface Burning Characteristics of Building Materials.

1.04 RELATED SECTIONS

- A. Section 012901 – Measurement and Payment.
- B. Section 014300 – Quality Requirements.
- C. Section 017423 – Cleaning Up.
- D. Section 017700 - Closeout.

1.05 ALTERATIONS, CUTTING, AND PROTECTION

- A. The Contractor is responsible to survey and record condition of existing facilities to remain in-place that may be affected by alteration operations. After alteration work is complete, survey conditions again and restore existing facilities to pre-alteration condition.
- B. Perform Work of moving, removal, cutting, and patching with trades qualified to perform Work in manner causing least damage to each type of Work.
- C. Provide shoring, needling, and bracing to keep structures structurally secure and free of damaging deflection for installation of new structural members.
- D. Do not pile material to endanger existing structures.
- E. Discoveries of construction, furnishings, and articles having historic or private value shall remain in possession of the DEP.

1. Promptly notify Construction Manager.
2. Protect discovery from damage from elements or Work.
3. Construction Manager will promptly transmit decision for disposition of discovery.
4. Store items to be retained by the DEP in safe, dry place on-site, or legally dispose of items which the DEP releases.

1.06 HOLES IN EXISTING CONCRETE

- A. When the Contractor is required to make new holes in existing concrete for piping, conduit, cables, or equipment, the Contractor shall accurately and carefully mark out the locations and the extent of cutting required and coordinate with the trade(s) involved. The Contractor shall make new holes using one (1) of the methods described below:
 1. Prior to drilling any openings, the Contractor shall determine the location, if any, of existing services concealed in and/or behind the construction to be drilled. X-ray the walls or slabs, if required to determine the location.
 2. The Contractor shall chip with an electric hammer with chisel point. Adjust the location of holes as necessary to avoid electrical conduits if encountered. Cut reinforcing steel after permission is received.

1.07 PROTECTION AND CONTINUITY OF UTILITIES AND OPERATIONS

- A. Protect existing utilities so they will continue to function during and after construction.
- B. Where interference with such facilities occurs, cooperate with owner of facility and, if necessary, alter facility to eliminate interference.
- C. Service Continuity:
 1. Provide and maintain continuous electrical, plumbing, and water services to all residential and commercial buildings within the Project area.
 2. Temporary outages are permitted only during cutover work at such times and places as pre-arranged with the Construction Manager. Keep such outages to minimum number and length of time. Make no outages without prior acceptance.
 3. Include costs for temporary equipment, materials, and Work required in Contract Price.
 4. Remove temporary equipment and materials when no longer required or at completion of Work.

1.08 QUALITY ASSURANCE

- A. Comply with the requirements specified in Section 014300.
- B. Adhere strictly to the manufacturer's current printed recommendations regarding temperature at time of application for all work involving epoxy, cement base coating and protective coating.
- C. Use only products of the specified Repair Mortar System Manufacturer(s) or an approved equal.
- D. Any changes in the specified repair mortar work methods shall be allowed only with the written acceptance of the Construction Manager.

PART 2 - PRODUCTS

2.01 MATERIALS

- A. Concrete repair mortar shall be a non-shrink, commercial formulation requiring only the addition of water with minimum 28-day compressive strength of 5,000 psi.
- B. Provide a non-shrink cementitious repair mortar material as manufactured by:
 - 1. Sika Repair 224 manufactured by Sika Corp.
 - 2. EMACO S88CI manufactured by Master Builder, Inc.
 - 3. Underlayment F-120 by Sauereisen, Inc.
 - 4. Or approved equal.
- C. Materials for finish patching shall be equal to those of adjacent construction.

2.02 PRODUCTS FOR PATCHING, EXTENDING, AND MATCHING

- A. Provide same products, salvaged materials, types of construction, or finish as that in existing structure, as needed to patch, extend, or match existing Work.
 - 1. Generally, Contract Documents will not define products or standards of workmanship present in existing construction, determine products by inspection, and necessary testing and workmanship by use of existing as sample of comparison.

PART 3 - EXECUTION

3.01 GENERAL

- A. All cutting and coring shall be performed in such a manner as to limit the extent of patching.
- B. All holes cut through concrete and masonry walls, slabs, or arches shall be core drilled unless otherwise accepted. No structural members shall be cut without acceptance of the Construction Manager and all such cutting shall be done in a manner directed by the Construction Manager. No holes may be drilled in beams or other structural members. All work shall be performed by mechanics skilled in this type of Work.
- C. Rough patching shall be such as to bring the cut or cored area flush with existing construction unless otherwise shown. Finish patching shall match existing surfaces.

3.02 PREPARATION

- A. Where new work conceals existing surfaces or spaces, the Contractor shall remove foreign substances such as accumulated dirt, dust, grease, sludge, and odoriferous material before concealing existing surfaces.
- B. Where surfaces are to remain exposed, the Contractor shall remove foreign substances described above.

3.03 REMOVAL, RELOCATION, AND SECURING MATERIALS AND EQUIPMENT

- A. Where existing materials and equipment are removed or relocated, remove materials no longer used such as studs, straps, conduits, ducts, wires, anchors, piping and supports. Remove or cut off concealed or embedded materials such as conduit, boxes, anchors, piping or other materials to not less than 3/4-inches below finished surface.
- B. Materials that cannot be removed shall be secured to adjacent structure to prevent coming loose.
- C. Repair affected surfaces to conform to type, quality, and finish of adjacent surfaces.

3.04 CUTTING

- A. Inspect existing conditions of Work, including components subject to damage or movement during cutting, patching, excavating, or backfilling.
- B. After uncovering Work, inspect conditions affecting installation of new materials.
- C. Do not cut or notch structural members without specific written acceptance of Construction Manager.

- D. Cutting shall be performed with a concrete saw and diamond saw blades of proper size.
- E. Corners of square or rectangular openings shall be cored. Do not overcut corners of openings. Corners shall be chipped out square, if required, so as not to cause cracking at the corners.
- F. Provide for control of slurry generated by sawing operation on both sides of element.
- G. When cutting reinforced concrete, the cutting shall be done so as not damage bond between the concrete and reinforcing steel left in structure. Cut shall be made so that steel neither protrudes nor is recessed from face of the cut.
- H. Adequate bracing and/or shoring of area to be cut shall be installed prior to start of cutting. Check area during sawing operations for cracking and provide additional bracing as required to prevent a partial release of cut area during sawing operations.
- I. Provide equipment of adequate size to remove cut panel.

3.05 CORING

- A. Coring shall be performed with an accepted non-impact rotary tool with diamond core drills. Size of holes shall be suitable for pipe, conduit, sleeve, equipment, or mechanical seals to be installed.
- B. Provide protection for existing equipment, utilities and critical areas against water or other damage caused by drilling operation.
- C. Slurry or tailings resulting from coring operations shall be removed from the area following drilling.

3.06 PATCHING

- A. Prepare surfaces to receive cementitious repair mortar in accordance with manufacturer's instructions.
- B. Mix the cementitious repair mortar material components in accordance with the manufacturer's instructions. Concrete surfaces should be surface saturated dry (SSD) with no standing water prior to mortar application.
- C. Work a wet scrub coat of the mortar per the manufacturer's recommendations into the pores and voids in the substrate and over the substrate prior to mortar application by trowel.
- D. Apply the cementitious repair mortar using a steel trowel to work the material into the surface. Fill voids from deepest to shallowest areas as the application work proceeds. Strictly follow the manufacturer's application requirements.

- E. Once the repair areas are filled with repair mortar, strike off the mortar level with the surrounding concrete substrate. Do not leave a broom finish. Finish with a steel trowel until closed up at the surface and flat.
- F. Cure the repair mortar in strict accordance with the manufacturer's instructions.

3.07 CLEANING

- A. Perform periodic and final cleaning as specified in Section 017423 and:
 - 1. Clean DEP-occupied areas daily.
 - 2. Clean spillage, overspray, and heavy collection of dust in DEP-occupied areas immediately.
- B. At completion of alterations work in each area, provide final cleaning and return space to condition suitable for use by the DEP.
- C. Remove debris from site each day. Removed material, except that listed or marked by the Construction Manager for retention, becomes property of Contractor.

3.08 CLOSEOUT ACTIVITIES

- A. Provide in accordance with Section 017700.

END OF SECTION 017329

NO TEXT ON THIS PAGE

SECTION 017423 - CLEANING UP

PART 1 - GENERAL

1.01 SUMMARY

- A. Execute cleaning during progress of Work and at completion of Work.
- B. Refer to Contract Sections for specific cleaning for Products or Work.

1.02 PAYMENT

- A. No separate payment shall be made for performing any Work required under this Section. All costs for Work required by this Section shall be included in the applicable lump sum(s), unit price(s), or allowance(s) as set forth in Section 012901.

1.03 DISPOSAL REQUIREMENTS

- A. Conduct cleaning and disposal operations to comply with local codes, ordinances, regulations, and anti-pollution laws. Do not burn or bury rubbish or waste materials on Project site. Do not dispose of volatile wastes, such as mineral spirits, oil, or paint thinner, in storm or sanitary drains. Do not dispose of wastes into streams or waterways.

1.04 RELATED SECTIONS

- A. General Conditions Article 4.12.
- B. General Conditions Article 4.13.
- C. Section 012901 – Measurement and Payment.
- D. Section 015000 – Temporary Facilities and Controls.
- E. Section 021600 – Excess Clean Fill, Contaminated Soil, and Groundwater Management and Disposal.

PART 2 - PRODUCTS

2.01 MATERIALS

- A. Use only those cleaning materials which will not create hazards to property and persons or damage surfaces of material to be cleaned.
- B. Use only cleaning materials recommended by manufacturer of surface to be cleaned.

PART 3 - EXECUTION

3.01 CLEANING DURING CONSTRUCTION

- A. Comply with General Conditions.
- B. At all times maintain areas covered by the contract and adjacent properties and public access roads free from accumulations of waste, debris, and rubbish caused by construction operations.
- C. During execution of work, clean site, adjacent properties, and public access roads and dispose of waste materials, debris, and rubbish to assure that buildings, grounds, and public properties are maintained free from accumulations of waste materials and rubbish. Unneeded construction equipment shall be removed and all damage repaired so that the public and property owners will be inconvenienced as little as possible.
- D. Wet down dry materials and rubbish to lay dust and prevent blowing dust.
- E. Cover or wet excavated material leaving and arriving at the site to prevent blowing dust. Clean the public access roads to the site of any material falling from the haul trucks.
- F. Where material or debris has washed or flowed into or been placed in existing watercourses, ditches, gutters, drains, pipes structures, work done under this contract, or elsewhere during the course of the Contractor's operations, such material or debris shall be entirely removed and satisfactorily disposed of during the progress of the work, and the ditches, channels, drains, pipes, structures, and work, etc., shall, upon completion of the work, be left in a clean and neat condition.
- G. On or before the completion of the work, the Contractor shall, unless otherwise especially directed or permitted in writing, tear down and remove all temporary buildings and structures built by him; shall remove all temporary works, tools, and machinery or other construction equipment furnished by him; shall remove, acceptably disinfect, and cover all organic matter and material containing organic matter in, under, and around privies, houses, and other buildings used by him; shall remove all rubbish from any grounds which he has occupied; and shall leave the roads and all parts of the premises and adjacent property affected by his operations in a neat and satisfactory condition.
- H. Provide on-site containers for collection and removal of waste materials, debris, and rubbish in accordance with applicable regulations.

3.02 FINAL CLEANING

- A. General: Perform final cleaning. Conduct cleaning and waste-removal operations to comply with local laws and ordinances and Federal and local environmental and antipollution regulations.

- B. Cleaning: Employ experienced workers or professional cleaners for final cleaning. Clean each surface or unit to condition expected in an average commercial building cleaning and maintenance program. Comply with manufacturer’s written instructions.
 - 1. Complete the following cleaning operations before requesting inspection for certification of Substantial Completion for entire Project or for a designated portion of Project:
 - a. Clean Project site, yard, and grounds, in areas disturbed by construction activities, including landscape development areas, of rubbish, waste material, litter, and other foreign substances.
 - b. Sweep paved areas broom clean. Remove petrochemical spills, stains, and other foreign deposits.
 - c. Rake grounds that are neither planted nor paved to a smooth, even-textured surface.
 - d. Remove tools, construction equipment, machinery, and surplus material from Project site.
 - e. Remove snow and ice to provide safe access.
 - f. Clean exposed exterior hard-surfaced finishes to a dirt-free condition, free of stains, films, and similar foreign substances. Avoid disturbing natural weathering of exterior surfaces. .
 - g. Remove labels that are not permanent.
 - h. Wipe surfaces of mechanical and electrical equipment and similar equipment. Remove excess lubrication, paint and mortar droppings, and other foreign substances.
 - i. Clean light fixtures, lamps, globes, and reflectors to function with full efficiency.
 - j. Leave Project clean and ready for occupancy.
- C. Pest Control: Comply with pest control requirements in Section 015000. Prepare written report.
- D. Construction Waste Disposal: Comply with waste disposal requirements in General Conditions Article 4.13.

- E. Contractor touchup paint or repaint damaged finishes on electrical items delivered to Project with finish coat of paint. Construction Manager will make final determination of items to be repainted or touched up.
- F. Prior to substantial completion the Contractor, with Construction Manager, shall conduct inspection of sight-exposed interior and exterior surfaces and work areas to verify Work and site is clean.

3.03 CLEANING OF CONCRETE STRUCTURES

- A. Clean thoroughly, using water under pressure.
 - 1. Isolate reservoir from system to avoid possibility of contaminating materials entering collection system and/or discharging to the Hudson River.
 - 2. Cleaning shall:
 - a. Remove deposits of foreign nature.
 - b. Broom walls, floor, and ceiling.
 - c. Avoid damage to structure.
 - 3. Water used in cleaning shall be collected and removed from site.

END OF SECTION 017423

SECTION 017700 - CONTRACT CLOSEOUT

PART 1 - GENERAL

1.01 RELATED DOCUMENTS

- A. Drawings and general provisions of the Contract, including General and Supplementary Conditions and other Division 01 Specification Sections, apply to this Section.

1.02 PAYMENT

- A. No separate payment shall be made for performing any Work required under this Section. All costs for Work required by this Section shall be included in the applicable lump sum(s), unit price(s), or allowance(s) as set forth in Section 012901.

1.03 SUMMARY

- A. Section includes administrative and procedural requirements for contract closeout, including, but not limited to, the following:
 - 1. Substantial Completion procedures.
 - 2. Final completion procedures.
 - 3. Warranties.
 - 4. Final cleaning.
 - 5. Repair of the Work.
 - 6. Specific closeout and special cleaning requirements for the Work in those Sections.

1.04 RELATED SECTIONS

- A. General Conditions Article 4
- B. General Conditions Article 7
- C. General Conditions Article 8
- D. Section 012901 - Measurement and Payment.
- E. Section 015000 – Temporary Facilities and Controls.
- F. Section 017423 - Cleaning Up.

- G. Section 017823 - Operations and Maintenance Manual.

1.05 SUBMITTALS

- A. Submit the following shop drawings in accordance with General Conditions Article 4.7.
- B. Contractor's List of Incomplete Items: Initial submittal at Substantial Completion.
- C. Certified List of Incomplete Items: Final submittal at Final Completion.
- D. Certificates of Release: From authorities having jurisdiction.
- E. Certificate of Insurance: For continuing coverage.
- F. Field Reports: Testing and Commissioning Reports.
- G. Schedule of Maintenance Material Items: For maintenance material submittal items specified in other Sections.

1.06 SUBSTANTIAL COMPLETION PROCEDURES

- A. Contractor to refer to General Conditions Article 7.2
- B. Contractor's List of Incomplete Items: Prepare and submit a list of items to be completed and corrected (Contractor's punch list), indicating the value of each item on the list and reasons why the Work is incomplete.
- C. Submittals Prior to Substantial Completion: Complete the following a minimum of **10** days prior to requesting inspection for determining date of Substantial Completion. List items below that are incomplete at time of request.
 - 1. Certificates of Release: Obtain and submit releases from authorities having jurisdiction permitting the DEP unrestricted use of the Work and access to services and utilities. Include occupancy permits, operating certificates, and similar releases.
 - 2. Submit closeout submittals specified in other Division 01 Sections, including project record documents, operation and maintenance manuals, final completion construction photographic documentation, damage or settlement surveys, property surveys, and similar final record information.
 - 3. Submit closeout submittals specified in individual Divisions 02 through 35 Sections, including specific warranties, workmanship bonds, maintenance service agreements, final certifications, and similar documents.
 - 4. Submit maintenance material submittals specified in individual Divisions 02 through 35 Sections, including tools, spare parts, extra materials, and

similar items, and deliver to location designated by Construction Manager. Label with manufacturer's name and model number where applicable.

- a. Schedule of Maintenance Material Items: Prepare and submit schedule of maintenance material submittal items, including name and quantity of each item and name and number of related Contract Sections. Obtain Construction Manager's signature for receipt of submittals.
5. Submit test records.
 6. Submit changeover information related to the DEP's occupancy, use, operation, and maintenance.
- D. Procedures Prior to Substantial Completion: Complete the following a minimum of 10 days prior to requesting inspection for determining date of Substantial Completion. List items below that are incomplete at time of request.
1. Advise the DEP of pending insurance changeover requirements.
 2. Make final changeover of permanent locks and deliver keys to the DEP. Advise the DEP's personnel of changeover in security provisions.
 3. Complete startup and testing of systems and equipment.
 4. Perform preventive maintenance on equipment used prior to Substantial Completion.
 5. Instruct the DEP's personnel in operation, adjustment, and maintenance of products, equipment, and systems. Submit demonstration and training video recordings specified in General Conditions Article 8.3 - Training.
 6. Advise the DEP of changeover in electrical power and other utilities.
 7. Participate with the DEP in conducting inspection and walkthrough with local emergency responders.
 8. Terminate and remove temporary facilities from Project site, along with mockups, construction tools, and similar elements.
 9. Remove labels that are not permanent labels.
 10. Complete final cleaning requirements, including touchup painting.
 11. Touch up and otherwise repair and restore marred exposed finishes to eliminate visual defects.

- E. Inspection: Submit a written request for inspection to determine Substantial Completion a minimum of ten (10) working days prior to date the work will be completed and ready for final inspection and tests. On receipt of request, Construction Manager will either proceed with inspection or notify Contractor of unfulfilled requirements. Construction Manager will prepare the Certificate of Substantial Completion after inspection or will notify Contractor of items, either on Contractor's list or additional items identified by Construction Manager, that must be completed or corrected before certificate will be issued.
 - 1. Reinspection: Request reinspection when the Work identified in previous inspections as incomplete is completed or corrected.
 - 2. Results of completed inspection will form the basis of requirements for final completion.

1.07 STARTING OF SYSTEMS

- A. Conform to the requirements of Sections 017823.
- B. Coordinate schedule for start-up of various equipment and systems.
- C. Notify Construction Manager seven (7) days prior to start-up of each item.
- D. Verify each piece of equipment or system has been checked for proper lubrication, drive rotation, belt tension, control sequence, and for conditions which may cause damage.
- E. Verify tests, meter readings, and specified electrical characteristics agree with those required by equipment or system manufacturer.
- F. Verify wiring and support components for equipment are complete and tested.
- G. Execute start-up under supervision of applicable manufacturer's representative in accordance with manufacturers' instructions.
- H. When specified in individual specification Sections, require manufacturer to provide authorized representative to be present at site to inspect, check, approve equipment or system installation prior to start-up, to supervise placing equipment or system in operation, and to train the DEP's staff.
- I. Submit a written report in accordance with General Conditions Article 4.7 that equipment or system has been properly installed and is functioning correctly.

1.08 DEMONSTRATION AND INSTRUCTIONS

- A. Conform to the requirements of Sections 017823.

- B. Utilize operation and maintenance manuals as basis for instruction. Review contents of manual with the DEP's personnel in detail to explain all aspects of operation and maintenance.
- C. Demonstrate start-up, operation, control, adjustment, troubleshooting, servicing, maintenance, and shutdown of each item of equipment.
- D. Prepare and insert additional data in operations and maintenance manuals when need for additional data becomes apparent during instruction.

1.09 TESTING, ADJUSTING AND BALANCING

- A. Adjust operating equipment to ensure smooth and unhindered operation.
- B. Reports will be submitted by the Contractor to Construction Manager indicating observations and results of tests and indicating compliance or non-compliance with requirements of Contract Documents.

1.10 PROJECT RECORDS DOCUMENTS

- A. The Contractor shall record any actual revisions to the Work and maintain one (1) set of the following Project Record Documents on Site:
 - 1. Contract Drawings, Specifications, and Addenda.
 - 2. Change Orders, Field Orders, and other written notices.
 - 3. Shop drawings, Product data, and samples.
 - 4. Records of surveying and layout Work.
 - 5. Project As-Built Drawings.
- B. In accordance with General Conditions Article 4.8, the Contractor shall record information on the Project As-Built Drawings concurrent with construction progress and store these documents separately from the documents used for construction.
 - 1. The DEP will supply a set of Contract Drawings. The Contractor shall mark thereon all revisions as the Work progresses in order to produce a set of as-built drawings.
 - 2. The Contractor shall note any changes made during construction by any of the Contractor's forces or those of any Subcontractors.
 - 3. The Contractor shall dimension the locations of buried or concealed Work, especially piping and conduit, with reference to exposed structures.

4. The Contractor shall dimension the installed locations of concealed service lines on the Site or within the structure by reference from the center line of the service to the structure column lines, or other main finished faces, or other structural points which are easily identified and located in the finished Work.
 5. Certificates of Substantial Performance and Total Performance shall not be issued until as-built drawings are complete and submitted, and the Contractor has satisfied all requirements for Substantial Performance and Total Performance of the Work.
- C. For Project Record Documents and Record Shop Drawings, the Contractor shall legibly mark each item to record actual construction including:
1. Field changes of dimensions and details.
 2. Measured horizontal and vertical locations of underground utilities and appurtenances, referenced to permanent surface improvements.
 3. Measured locations of internal utilities and appurtenances which are concealed in construction, referenced to visible and accessible features of the Work.
 4. Changes in the Work caused by Site conditions, or originated by the DEP, the Engineer, the Contractor, Preselected Equipment Vendors, or Subcontractors and by addenda, supplemental drawings, Site instructions, supplementary instructions, change orders, correspondence, and directions of any regulatory authorities.
 5. Record the location of concealed mechanical services and electrical main feeders, junction boxes and pull boxes.
- D. Upon completion of the Work, the Contractor shall prepare two (2) CD-ROM sets of the Record Shop Drawings and an index.
- E. The Record Shop Drawings CD-ROM index shall identify the DEP's project number, project name, and Contract number and the contents of each CD in the following format:
1. The index shall include the following columns of information for each Record Shop Drawing:
 - a. CD number.
 - b. Contract Specification Section number.
 - c. Contract Section Specification title.
 - d. Shop drawing transmittal number.

- e. Shop drawing equipment description including Preselected Equipment Vendor and Supplier.
2. The index shall be printed by the following two (2) sorts:
 - a. Primary sort: Contract Specification Section number. Secondary sort: shop drawing transmittal number.
 - b. Primary sort: CD number. Secondary sort: Contract Specification Section number.
3. The index shall be generated using Microsoft Excel software. A copy of the electronic file shall be furnished to the DEP.
4. The Contractor shall remove the Architect/Engineer seal from all documents.
5. The Contractor shall provide a set of Project Record Documents on CD-ROM in an electronic format compatible with the DEP CD-ROM record standards. All drawings are to be provided electronically on CD-ROM in both AutoCAD (latest version) and Adobe Acrobat PDF (latest version). Also provide a set of CD-ROMs containing the software implemented on this project, including standard software and custom application software. Also provide a set of CD-ROMs containing the various programming tools and files necessary for maintenance, editing, backing up and restoring programmable equipment implemented on this project.

1.11 EQUIPMENT INVENTORY SPREADSHEET

- A. As part of the DEP's asset management program, the Contractor shall complete all fields for the equipment inventory file for each piece of equipment and device provided under this Contract, as a requirement for Substantial Performance. An electronic format of the equipment inventory spreadsheet will be provided on a CD to the successful Contractor.

1.12 EQUIPMENT PREVENTATIVE MAINTENANCE SPREADSHEET

- A. As part of the DEP asset management program, the Contractor shall complete all fields for each piece of equipment and device provided under this Contract, as a requirement for Substantial Completion. The Contractor shall transfer all of the manufacturer's recommended preventative maintenance tasks and frequencies into the spreadsheet. An electronic format of the equipment inventory spreadsheet will be provided on a CD to the successful Contractor.

1.13 PROTECTING INSTALLED CONSTRUCTION

- A. Protect installed Work and provide special protection where specified in individual Contract Sections.

- B. Provide temporary and removable protection for installed products. Control activity in immediate work area to prevent damage.
- C. Provide protective coverings at walls, projections, jambs, sills, and soffits of openings.
- D. Prohibit traffic from landscaped areas.

1.14 SPARE PARTS AND MAINTENANCE PRODUCTS

- A. Furnish spare parts, maintenance, and extra products in quantities specified in individual specification sections.
- B. Deliver to the Construction Manager; obtain receipt prior to final payment.
- C. Crate in containers designed for prolonged storage suitable for handling with hoisting equipment containers:
- D. Stencil on containers:
 - 1. Manufacturer/supplier name.
 - 2. Unit name.
 - 3. Spare part name.
 - 4. Manufacturer catalogue number.
 - 5. Other identifying information.
 - 6. Precautionary information.

1.15 FINAL COMPLETION PROCEDURES

- A. Contractor to refer to General Conditions Article 7.3
- B. Submittals Prior to Final Completion: Before requesting final inspection for determining final completion, complete the following:
 - 1. Submit a final Application for Payment according to the General Conditions.
 - 2. Certified List of Incomplete Items: Submit certified copy of Construction Manager's Substantial Completion inspection list of items to be completed or corrected (punch list), endorsed and dated by Construction Manager. Certified copy of the list shall state that each item has been completed or otherwise resolved for acceptance.

3. Certificate of Insurance: Submit evidence of final, continuing insurance coverage complying with insurance requirements.
 4. Provide all Warranties required by the Contract
- C. Inspection: Submit a written request for final inspection to determine acceptance a minimum of ten (10) working days prior to date the work will be completed and ready for final inspection and tests. On receipt of request, Construction Manager will either proceed with inspection or notify Contractor of unfulfilled requirements. Construction Manager will prepare a final Certificate for Payment after inspection or will notify Contractor of Work that must be completed or corrected before certificate will be issued.
1. Reinspection: Request reinspection when the Work identified in previous inspections as incomplete is completed or corrected.

1.16 LIST OF INCOMPLETE ITEMS (PUNCH LIST)

- A. Organization of List: Include name and identification of each space and area affected by construction operations for incomplete items and items needing correction including, if necessary, areas disturbed by Contractor that are outside the limits of construction.
1. Submit list of incomplete items in the following format:
 - a. MS Excel electronic file. Construction Manager will return annotated file.

1.17 SUBMITTAL OF PROJECT WARRANTIES

- A. Time of Submittal: Submit written warranties on request of Construction Manager for designated portions of the Work where commencement of warranties other than date of Substantial Completion is indicated, or when delay in submittal of warranties might limit the DEP rights under warranty. A general list of warranted items are presented in the table below. This is not considered to be a complete list of all warranty requirements; additional warranty requirements in individual specification sections shall take precedence over this table.

Table 017700-1 – Extended Warranties

Item No.	Item	Specification Section	Specification Details
1	Control of Materials - Warranty	GC Article 8.4.3 and 016100 - 1.10.B	Warranties specified in other Sections shall be in addition to, and run concurrent with, other warranties required by the Contract Documents. Manufacturer's disclaimers and limitations on product warranties do not relieve Contractor of obligations under requirements of the Contract Documents.

Item No.	Item	Specification Section	Specification Details
2	Prefabricated Expansion Joint Assemblies - Warranty	058100 - 1.10.A	Submit written warranty executed by the Contractor, installer and the manufacturer, agreeing to provide materials and labor to repair or replace expansion joint assemblies that fail in materials or workmanship within five (5) years after date of issuance of the Certificate of Final Completion.
3	Cold-Fluid-Applied Waterproofing - Warranty	071416 - 1.07.A.1	Special Manufacturer's Warranty: Manufacturer's standard form in which waterproofing manufacturer and Installer agree to repair or replace waterproofing that does not comply with requirements or that fails to remain watertight within specified warranty period five (5) years from date of Substantial Completion).
4	Metal Composite Material Panels - Warranty	074213 - 1.11.A.2	Warranty Period: Five (5) years from date of Substantial Completion.
5	Metal Composite Material Panels - Warranty	074213 - 1.11.B.2	Special Warranty on Panel Finishes: Manufacturer agrees to repair finish or replace metal composite material panels that show evidence of deterioration of factory-applied finishes within specified warranty period (ten (10) years from date of Substantial Completion).
6	Joint Sealants - Warranty	079200 - 1.09.A.1	Installer agrees to repair or replace joint sealants that do not comply with performance and other requirements specified in this Section within specified warranty period (two (2) years from date of Substantial Completion).
7	Overhead Coiling Grilles - Warranty	083326 - 1.07.A.1	Special Warranty: Manufacturer agrees to repair or replace components of grilles that fail in materials or workmanship within specified warranty period (two (2) years from date of Substantial Completion).
8	Glazing Plastic - Guaranty	088400 - 1.10.A	The Contractor unconditionally guaranties all glazing plastic furnished and installed by it against defects or failures of any kind for a period of three (3) years from the issuance of Certificate of Final Completion.

Item No.	Item	Specification Section	Specification Details
9	Play Field Equipment & Structures - Warranty	116800 - 1.08.A.2	Manufacturer agrees to repair or replace components of playground equipment that fail in materials or workmanship within specified warranty period (a minimum of two (2) years from date of Substantial Completion for all components and finishes).
10	LED Lighting - Materials and Components	265619 - 2.01.A.12	LED Floodlight Type FL-A: The LED luminaire shall have a ten (10) year warranty.
11	LED Lighting - Materials and Components	265619 - 2.01.B.12	LED Floodlight Type FL-B: The LED luminaire shall have a ten (10) year warranty.
12	LED Lighting - Materials and Components	265619 - 2.01.C.11	LED Area Light Type LP-A, LP-B/C/D & Lp-G: The LED luminaire shall have a five (5) year warranty.
13	LED Lighting - Materials and Components	265619 - 2.01.D.9	LED Wall Mounted Light Type WP-A: The LED luminaire shall have a five (5) year warranty.
14	LED Lighting - Materials and Components	265619 - 2.01.E.11	Led Floodlight Type for Series L1 – L7 Lighting Poles: The LED luminaire shall have a ten (10) year warranty
15	LED Lighting - Materials and Components	265619 - 2.01.F.11	Led Area Light for Cove Park Option A: The LED luminaire shall have a five (5) year warranty.
16	LED Lighting - Materials and Components	265619 - 2.01.H.16	LED Strip Lighting Fixture: The LED strip lighting fixtures shall have a five (5) year warranty.
17	LED Lighting - Materials and Components	265619 - 2.01.I.12	LED String of Pucks Lighting Fixture: The LED string of pucks lighting fixtures shall have a five (5) year warranty.
18	LED Lighting - Materials and Components	265619 - 2.01.J.5	LED in-Grade Lighting Fixture and Led Power Supply: The LED modules shall have a fifty thousand (50,000) hours and twenty (20) year warranty.
19	Unit Paving - Warranty	321400 - 1.11.B	Warrant the metal edge restraint to be free from defect or failure for a period of fifteen (15) years from the date of purchase .

Item No.	Item	Specification Section	Specification Details
20	Bound Crushed Stone Surfacing - Warranty	321560 - 1.11.A	Warrant the bound crushed stone surfacing to be free from defect for a period of three (3) years from the date of substantial completion . The warranty shall include defective work, breakage, deformation, fading and loosening.
21	Bound Crushed Stone Surfacing - Warranty	321560 - 1.11.B	Warrant the metal edge restraint to be free from defect or failure for a period of fifteen (15) years from the date of purchase .
22	Tactile Warning Surfacing - Warranty	321726 - 1.07.A.2	Manufacturer agrees to repair or replace components of tactile warning surfaces that fail in materials or workmanship within specified warranty period five (5) years from date of Substantial Completion).
23	Playground Protective Surfacing - Warranty	321816 - 1.10.A	Manufacturer agrees to repair or replace components of playground surface system that fail in materials or workmanship within specified warranty period of ten (10) years .
24	Gate Operators - Warranty	323111 - 1.07	Manufacturer's Standard Limited Warranty Period: two (2) years from date of Substantial Completion .
25	Planting Irrigation - Guarantee	328400 - 3.11.B	Replace any part or parts found to be defective within the guarantee period at no cost to the Project, except repairs or replacement necessitated by damage caused by other trades. Materials, fixtures, and equipment are to be warranted for one (1) year from installation date . Warranty must include computer hardware and software. This guarantee is to be certified in writing by factory representatives.
26	Planting - Warranties & Guarantees	329300 - 1.13.A	A. Warranty Period (Two-Year per Section 329700) 1.13.A.5 - Replacements shall be provided within thirty (30) days of Notification of Rejection. Any delay in the completion of planting operations, which extends the planting into more than one growing season, shall extend the warranty period correspondingly.
27	Planting - Warranties & Guarantees	329300 - 1.13.B	Replacements: Without cost to the DEP and as directed by the Construction Manager, replace all plants not meeting the requirements above during

Item No.	Item	Specification Section	Specification Details
			and at the end of the two (2) year warranty period within thirty (30) days.
28	Planting - Container Plant Material - Species	329300 - 2.01.F	Replace all plant materials, determined by the Construction Manager within two (2) years following the final acceptance of the project , to be untrue to the species, clone, and/or variety specified, to the equal condition of adjacent plants at the time of replacement, at no additional cost to the DEP.
29	Landscape Maintenance - Execution	329700 - 3.01.I	Plant replacement: All costs associated with replacement plants are covered under two (2) year warranty and are the Contractors cost.
30	Operation & Maintenance of Roadways - Warranty	340113 - 1.05.A	The completed marking installation shall be warranted to the DEP against peeling, chipping, flaking, delamination and shoving for a period of one year from the date of issuance of the Certificate of Final Completion . The warranty shall grant the DEP a direct right of action. The manufacturer shall warrant that the materials provided to the applicator are free from manufacturing defects . The applicator shall warrant that the workmanship has been completed complying to the installation methods here within.
31	Rolling Gates & Appurtenances - Warranty	353130 - 1.08.A	Rolling gates shall operate in accordance with Contract requirements and be free of defects in material and workmanship for a period of not less than three (3) years from the date of final acceptance.
32	Swing Gates & Appurtenances - Warranty	353131 - 1.08.A	Swing gates shall operate in accordance with Contract Documents and be free of defects in material and workmanship for a period of not less than three (3) years from the date of final acceptance.
33	Stoplog & Appurtenances - Warranty	353132 - 1.07.A	Stoplog shall operate in accordance with Contract requirements and be free of defects in material and workmanship for a period of not less than three (3) years from the date of final acceptance.

- B. Organize warranty documents into an orderly sequence based on the table of contents of Contract Documents.
 - 1. Bind warranties and bonds in heavy-duty, three-ring, vinyl-covered, loose-leaf binders, thickness as necessary to accommodate contents, and sized to receive 8-1/2-by-11-inch paper.
 - 2. Provide heavy paper dividers with plastic-covered tabs for each separate warranty. Mark tab to identify the product or installation. Provide a typed description of the product or installation, including the name of the product and the name, address, and telephone number of Installer.
 - 3. Identify each binder on the front and spine with the typed or printed title "WARRANTIES," Project name, and name of Contractor.
 - 4. Warranty Electronic File: Scan warranties and bonds and assemble complete warranty and bond submittal package into a single indexed electronic PDF file with links enabling navigation to each item. Provide bookmarked table of contents at beginning of document.
- C. Provide additional copies of each warranty to include in operation and maintenance manuals.

PART 2 - PRODUCTS

- A. Not Used

PART 3 - EXECUTION

3.01 FINAL CLEANING

- A. General: Perform final cleaning in accordance with Section 017423.
- B. Construction Waste Disposal: Comply with waste disposal requirements in Section 015000.

3.02 REPAIR OF THE WORK

- A. Complete repair and restoration operations before requesting inspection for determination of Substantial Completion.
- B. Repair or remove and replace defective construction. Repairing includes replacing defective parts, refinishing damaged surfaces, touching up with matching materials, and properly adjusting operating equipment. Where damaged or worn items cannot be repaired or restored, provide replacements. Remove and replace operating components

that cannot be repaired. Restore damaged construction and permanent facilities used during construction to specified condition.

1. Remove and replace chipped, scratched, and broken glass, reflective surfaces, and other damaged transparent materials.
2. Touch up and otherwise repair and restore marred or exposed finishes and surfaces. Replace finishes and surfaces that already show evidence of repair or restoration.
 - a. Do not paint over "UL" and other required labels and identification, including mechanical and electrical nameplates. Remove paint applied to required labels and identification.
3. Replace parts subject to operating conditions during construction that may impede operation or reduce longevity.
4. Replace burned-out bulbs, bulbs noticeably dimmed by hours of use, and defective and noisy starters in fluorescent and mercury vapor fixtures to comply with requirements for new fixtures.

3.03 ADJUSTING

- A. Adjust operating products and equipment to ensure smooth and unhindered operation.

END OF SECTION 017700

NO TEXT ON THIS PAGE

SECTION 017823 - OPERATION AND MAINTENANCE MANUAL

PART 1 - GENERAL

1.01 DESCRIPTION

- A. This Section includes procedural requirements for providing, compiling, and submitting operation and maintenance data required for this project.

1.02 PAYMENT

- A. No separate payment shall be made for performing any Work required under this Section. All costs for Work required by this Section shall be included in the applicable lump sum(s), unit price(s), or allowance(s) as set forth in Section 012901.

1.03 SUMMARY

- A. This section includes administrative and procedural requirements for preparing operation and maintenance manuals, including the following:
 - 1. General contents of data.
 - 2. Specific data for each equipment and system.
 - 3. Manual for materials and finishes.
 - 4. Assembly.

1.04 RELATED SECTIONS

- A. General Conditions Article 4.7 – Shop Drawings and Other Submittals.
- B. General Conditions Article 8.2 – Operations, Equipment and Maintenance Manuals.

1.05 DEFINITIONS

- A. System: An organized collection of parts, equipment, or subsystems united by regular interaction.
- B. Subsystem: A portion of a system with characteristics similar to a system.

1.06 SUBMITTALS

- A. O&M Manual Content: Operations and maintenance manual submittal requirements are specified in individual Contract Sections for the Products for which they must be

supplied. Submit reviewed manual content formatted and organized by this Section and as defined in General Conditions Article 4.7 and Article 8.2.

1. Where applicable, clarify and update reviewed manual content to correspond to revisions and field conditions.
- B. Initial O&M Manual: Submit electronic copy in .pdf form, of each manual as defined in General Conditions Article 8.2. Architect/Engineer will comment on whether general scope and content of manual are acceptable.
- C. Pre-Final Manual Submittal: Submit two (2) copies and an electronic copy in .pdf form, of each manual in final form prior to requesting inspection for Substantial Completion and as defined in General Conditions Article 8.2. Architect/Engineer will return one (1) copy with comments.
1. The contractor to correct or revise each manual to comply with Architect/Engineer's comments.
- D. Submit six (6) copies and an electronic copy in .pdf form of each corrected manual as a final manual within 15 days of receipt of Architect/Engineer's comments and prior to commencing startup, commissioning, and/or training.
- 1.07 FORMAT (HARDCOPY)
- A. Prepare data in the form of an O&M instructional manual.
- B. Binders: Commercial quality, 8-1/2 x 11-inch three-hole post type binders with hardback, 3-inch maximum binder size. When multiple binders are used, correlate data into related consistent groupings. Three ring binders are not acceptable.
- C. Arrange contents by Specification Section numbers and sequence of Table of Contents of this Project Manual.
- D. Provide tabbed fly leaf for each separate product and system, with printed description of product and major component parts of equipment. Insert type tab labels must be secured or bonded to prevent the labels from falling out.
- E. Text: Manufacturer's printed data, or typewritten data on 20-pound paper.
- F. Drawings: Provide with reinforced punched binder tab. Bind in with text; fold larger drawings to size of text pages and insert into clear plastic envelopes that can be secured into the three-hole post binders.

1.08 FORMAT (ELECTRONIC DOCUMENTATION)

- A. The Contractor must provide Operation and Maintenance Manual information specific to the configuration of the project in electronic form. Documents should be formatted like a web site complete with index page and Table of Contents. The electronic format must be such that the DEP is able to load the files onto a server to provide online access via any standard web browser. The Contractor shall make use of HTML (for text based documents) and PDF (for CAD type drawings) file formats. The complete document shall be provided on a CD.
- B. The electronic O&M data must be organized in a logical manner to aid operation in troubleshooting and information retrieval.

1.09 QUALITY ASSURANCE

- A. Preparation of data shall be performed by personnel:
 - 1. Trained and experienced in O&M of described equipment.
 - 2. Familiar with requirements of this section.
 - 3. Skilled as technical writers to the extent required to communicate the essential data to the Reader.
 - 4. Skilled as drafters competent to prepare any required drawings.

PART 2 - PRODUCTS

(Not Used)

PART 3 - EXECUTION

3.01 GENERAL CONTENTS OF DATA

- A. Each individual manual shall contain equipment data pertaining to not more than one Specification section number as indicated in the Contract Documents.
 - 1. Completed Form 017823-1, Contractor's Submittal Form. An electronic copy of Form 017823-1 will be provided to the Contractor.
- B. Title Sheet: First page in data listing following:
 - 1. Title: "OPERATION AND MAINTENANCE INSTRUCTIONS".
 - 2. Title of Project: As shown on Contract Documents.

3. Name(s) of applicable building(s) or structure(s) in which equipment is located.
4. Name of equipment as described in Contract Documents.
5. Contractor's name, address, and telephone number.
6. Subcontractor's name, address, and telephone number if equipment is provided by Subcontractor.
7. Contractor's or Subcontractor's purchase order number, manufacturer's shop order number or other such numbers required for parts and service ordering.
8. Manufacturer's name, address, and telephone number.
9. Name, address, and telephone number for local source of supply for parts and service.

C. Equipment List: Immediately following title sheet containing the following:

1. Table of Contents: Immediately following equipment list. Arrange in logical, systematic order and shall include as minimum each tabbed divider. Each page shall be numbered.
2. Tabbed Dividers: Insert tabbed section dividers between each major section
 - a. Provide title of section on each tab.
 - b. Provide table of contents for each tabbed section, arranged in systematic order.
3. Equipment Data Sheets: Provide catalog sheets showing configuration, manufacturer's specifications, models, options, and styles of equipment and major components being provided. Product data sheets will show project specific information with inapplicable information deleted by crossing out or removal. Include in tabbed section(s).
4. Text:
 - a. Include only those sheets applicable to Project.
 - b. Each sheet shall:
 - (1) Identify specific equipment or part installed.
 - (2) Identify text applicable to equipment or part installed.
 - (3) Do not include inapplicable information or neatly strike it out.
5. Drawings:

- a. Supplement text with drawings to clearly illustrate following:
 - (1) Equipment and components.
 - (2) Relations of component parts of equipment and systems.
 - (3) Control and flow diagrams.
 - b. Actual drawings of equipment from manufacturer. “Typical” drawings are not acceptable, unless they accurately illustrate actual installation for this Contract.
6. Specially written information, as required to supplement text for particular installation.
- a. Provide explanation of interrelationships of equipment and components, and effects one component has on another or entire system.
 - b. Provide overall instructions and procedures for equipment tying in instructions and procedures for separate components into unified instructional package.
 - c. Provide glossary of any special terms used by the manufacturer if applicable.
 - d. Organize in consistent format under separate headings for different O&M procedures.
 - e. Provide logical sequence of instructions in order of O&M action required for each procedure.

3.02 SPECIFIC DATA FOR EACH ITEM OF EQUIPMENT AND/OR SYSTEM

A. For each item of equipment and system include:

1. Completed Equipment Data Form typewritten on copy of Form 017823-2 to Section 017823. An electronic copy of Form 017823-2 will be provided to the Contractor.
2. Description of equipment and component parts:
 - a. Function.
 - b. Normal operating characteristics.
 - c. Limiting conditions.
 - d. Performance curves.
 - e. Engineering data.

- f. Test as applicable.
 - g. Complete nomenclature and model number of replaceable parts including keyed labeled exploded diagram.
 - h. Complete nameplate data.
3. Operating Procedures:
- a. Startup and break-in.
 - b. Normal operating instructions.
 - c. Regulation and control.
 - d. Stopping and shutdown.
 - e. Emergency instructions.
 - f. Summer and winter operating instructions, as applicable.
 - g. Special operating instructions.
4. Maintenance Procedures:
- a. Routine maintenance operations.
 - b. Guide to troubleshooting.
 - c. Disassembly, repair, and reassembly instructions.
 - d. Alignment, adjusting, and checking instructions.
5. Servicing and Lubrication Schedule:
- a. List of lubricants required and quantity to be applied.
 - b. Schedule of lubrication.
 - c. Schedule for other routine maintenance.
6. Manufacturer's printed instructions regarding safety precautions for both (a) protection of personnel operating equipment and systems and (b) prevention of damage to equipment and systems.
7. Description of sequence of operation of controls.
8. Assembly drawings and diagrams required for maintenance.
9. Manufacturer's parts list and illustrations

- a. Predicted life of parts subject to wear.
 - b. Items recommended to be stocked by the DEP as spare parts and quantities of same.
 10. Accepted control diagrams such as ladder diagrams, instrumentation loop diagrams, and electrical schematics.
 11. Bill of material.
 12. Other data as required under applicable Contract Sections.
 13. Operating Procedures:
 - a. Routine and normal operating instructions.
 - b. Sequences required.
 - c. Special operating instructions.
 14. Maintenance Procedures:
 - a. Routine maintenance operations.
 - b. Guide to troubleshooting.
 - c. Disassembly, repair, and reassembly instructions.
 - d. Adjustment and checking instructions.
 15. Manufacturer's printed instructions regarding safety precautions for both:
 - a. Protection of personnel operating equipment and systems.
 - b. Prevention of damage to equipment and systems.
 16. List of all the original manufacturer's components, spare parts with diagram, and recommended quantities to be maintained in storage by the DEP.
 17. Other data as required under pertinent sections of Specifications.
- B. Each electric and electronic system, as applicable to equipment such as switchgear, motor control centers, panel boards, switchboards, starters, breakers, and relays shall include:
1. Description of System and Component Parts:
 - a. Function.
 - b. Normal operating characteristics.
 - c. Limiting conditions.

- d. Performance curves.
 - e. Engineering data.
 - f. Rating tables.
 - g. Tests, as applicable.
 - h. Complete nomenclature and model number of replaceable parts.
 - i. Complete nameplate data.
2. Circuit Directories of Panel Boards:
 - a. Electrical service.
 - b. Controls.
 - c. Communications.
 3. Complete instrumentation
 - a. Loop diagrams.
 - b. Tabulated listing of components in each control circuit or loop.
 4. Operating Procedures:
 - a. Routine and normal operating instructions.
 - b. Sequences required.
 - c. Special operating instructions.
 5. Maintenance Procedures:
 - a. Routine maintenance operations.
 - b. Guide to troubleshooting.
 - c. Disassembly, repair, and reassembly instructions.
 - d. Adjustment and checking instructions.
 6. Manufacturer's printed instructions regarding safety precautions for both:
 - a. Protection of personnel operating equipment and systems.
 - b. Prevention of damage to equipment and systems.

7. List of original all of the manufacturer's components, spare parts with diagram, and recommended quantities to be maintained in storage.
 8. Other data as required under pertinent sections of Contract Documents.
- C. Prepare and include additional data when need for such data becomes apparent during instruction of the Owner's personnel. Differences between the equipment O&M manual and the manufacturers training session shall result in the training and/or O&M Manual being corrected.

3.03 MANUAL FOR MATERIALS AND FINISHES

- A. Building Products, Applied Materials, and Finishes: Include product data, with catalog number, size, composition, and color and texture designations. Provide information for re-ordering custom manufactured products.
- B. Instructions for Care and Maintenance: Include manufacturer's recommendations for cleaning agents and methods, precautions against detrimental agents and methods, and recommended schedule for cleaning and maintenance.
- C. Moisture Protection and Weather Exposed Products: Include product data listing applicable reference standards, chemical composition, and details of installation. Provide recommendations for inspections, maintenance, and repair.
- D. Additional Requirements: As specified in individual product specification sections.
- E. Provide a listing in Table of Contents for design data, with tabbed fly sheet and space for insertion of data.

3.04 ASSEMBLY

- A. Assemble in six (6) sets.
- B. Remove bindings of individual manuals.
- C. Insert index tabs labeled with the respective piece of equipment to separate individual manuals.
- D. Provide a Table of Contents at the front of each volume showing the equipment items in the order in which they appear in the volume. Each equipment items shall include the functional name, applicable specifications section, and the plan listing, if any.
- E. The preventive maintenance schedule shall be bound in the front of each section immediately following the index tab sheet. The schedule shall be identified with respect to the piece of equipment it is referring to.
- F. Sheet Size: 8-1/2 x 11 sheets.

- G. Drawings may be on 11 x 17-inch sheets folded to 8-1/2 x 11 inches.
- H. Engrave on covers and end of binder, title OPERATIONS AND MAINTENANCE INSTRUCTIONS, name of Project, DEP’s project number, date of Contract, and volume number with subject matter of contents, and Owner’s name.

FORM 017823-1 Page 1 of 5 CONTRACTOR SUBMITTAL FORM			
TO: (Engineer) (Address) (City, State, Zip) (Attn:)		DATE:	
		SPECIFICATION SECTION TITLE:	
		SECTION NO.:	
		MANUFACTURER/ VENDOR:	
FROM: (Contractor) (Address) (City, State, Zip)		NO. OF COPIES SUBMITTED TO CONSTRUCTION MANAGER:	
		SIGNATURE OF CONTRACTOR:	
GENTLEMEN: We have checked the O&M manual submittal dated _____, 20__, and have found it to be in accordance with the requirements of Specification Section 017823 as noted below.			
FORMAT Size: 8-1/2 x 11 or 11 x 17 Paper: 20-lb minimum Text: Printed data/neatly typed Drawings: Standard size bound in text; in text-size labeled envelopes Tabbed Section Dividers Cover Label: Title Project name Building/structure ID Equipment name Specification section Binders: 3-ring			

FORM 017823-1 Page 2 of 5 CONTRACTOR SUBMITTAL FORM			
Provided	Not Applicable	Page No.	
3.01 GENERAL CONTENTS			
			A. Section number - one specification only
			B. Title Page
			1. Title
			2. Project title
			3. Building/structure ID
			4. Equipment name
			5. Contractor ID
			6. Subcontractor ID
			7. Purchase order data
			8. Manufacturer ID
			9. Service/parts supplier ID
			C. Product List
			D. Table of Contents
			E. Tabbed Sections
			F. Pertinent data sheets
			1. Annotated as needed
			G. Text
			1. Pertinent to project
			2. Annotated
			H. Drawings
			1. Supplement text
			a. Illustrate product and components
			b. Relations of equipment systems
			c. Control and flow diagrams
			2. Actual drawing of project equipment

FORM 017823-1 Page 3 of 5 CONTRACTOR SUBMITTAL FORM			
Provided	Not Applicable	Page No.	
3.01 GENERAL CONTENTS			
			I. Special Information
			1. Interrelationships of equipment and components
			2. Instructions and procedures provided
			3. Instructions organized in consistent format
			4. Instructions in logical sequence
			5. Glossary
			J. Warranty, Bond, Service Contract
3.02 SPECIFIC CONTENTS (EQUIPMENT/SYSTEMS ONLY)			
			A. For each item of equipment
			1. Complete Form 2 to Section 017823
			2. Description of Unit and Components
			a. Equipment functions
			b. Normal operating characteristics
			c. Limiting conditions
			d. Performance curves
			e. Engineering data
			f. Test data
			g. Replaceable parts list (with numbers)
			h. Nameplate data
			i. P&ID numbers
			3. Operating Procedures
			a. Startup, break-in
			b. Routine/normal operation
			c. Regulation and control
			d. Stopping and shutdown
			e. Emergency

FORM 017823-1 Page 4 of 5 CONTRACTOR SUBMITTAL FORM			
Provided	Not Applicable	Page No.	
3.02 SPECIFIC CONTENTS (EQUIPMENT/SYSTEMS ONLY)			
			3. Operating Procedures (continued)
			f. Seasonal operation
			g. Special instructions
			4. Maintenance Procedures
			a. Routine/normal instructions
			b. Troubleshooting guide
			c. Disassembly/repair/assembly
			d. Alignment, adjusting and checking instructions
			5. Servicing and Lubrication
			a. List of lubricants
			b. Lubrication schedule
			c. Maintenance schedule
			6. Safety Precautions/Features
			7. Sequence of Operation of Controls
			8. Assembly Drawings
			9. Parts List and Illustrations
			a. Predicted life
			b. Spare parts list
			10. Control Diagrams/Schematics
			11. Bill of Materials
			12. Other Data as Required

FORM 017823-1 Page 5 of 5 CONTRACTOR SUBMITTAL FORM			
Provided	Not Applicable	Page No.	
3.02 SPECIFIC CONTENTS (EQUIPMENT/SYSTEMS ONLY)			
			B. Each electrical and electronic system
			1. Description
			a. Equipment functions
			b. Normal operating characteristics
			c. Performance curves
			d. Engineering data
			e. Test data
			f. Replaceable parts list (with numbers)
			g. Nameplate data
			h. P&ID numbers
			2.Circuit and Panel Board Directories
			a. Electrical
			b. Controls
			c. Communications
			3. Instrumentation
			a. Loop Diagrams
			b. Components list each circuit/loop
			4. Operation Procedures
			a. Routine/normal operating instructions
			b. Sequences required
			c. Special operating instruction
			5. Maintenance Procedures
			a. Routine/normal instructions
			b. Troubleshooting guide
			c. Disassembly/reassembly
			d. Adjusting and checking
			6. Safety Precautions/Features
			7. Spare Parts List
			8. Additional Data

FORM 017823-2 Page 1 of 4 EQUIPMENT DATA FORM			
PROJECT NAME			
CONTRACT NO.			
CONTRACTOR			
EQUIPMENT NO.		ASSET NO.*	
DESCRIPTION		MAINT. NO.*	
LOCATION			
MANUFACTURER			
PURCHASED FROM			
VENDOR ORDER NO.		PURCHASE \$	
DATE OF PURCHASE			
LOCAL SUPPLIER			
ADDRESS			
PHONE NO.			
MODEL NO.			
NO. OF UNITS		SERIAL NOS.	
*By Owner			

FORM 017823-2 Page 2 of 4 EQUIPMENT DATA FORM			
NAMEPLATE DATA			
ELECTRIC MOTOR		PUMP/HVAC UNIT	
MANUFACTURER		MANUFACTURER	
TYPE	[] AC [] DC	TYPE	
HORSEPOWER		SIZE	
RPM		CAPACITY	
VOLTAGE		PRESSURE	
AMPERAGE		ROTATION	
PHASE		IMPELLER SIZE	
FRAME		IMPELLER MATERIAL	
DRIVE/REDUCER		OTHER (I&C)	
MANUFACTURER		MANUFACTURER	
TYPE	[] GEAR	TYPE	
	[] V-BELT		
	[] CHAIN		
	[] VARIDRIVE	SIZE	
SERVICE FACTOR		CAPACITY	
RATIO		RANGE	

FORM 017823-2 Page 4 of 4 EQUIPMENT DATA FORM				
LUBRICANT/RECOMMENDED SPARE PARTS LIST				
EQUIPMENT NO.		ASSET NO.*		
DESCRIPTION		MAINT. NO.*		
LUBRICANT LIST				
REFERENCE SYMBOL	LUBRICANT TYPE (MILITARY STANDARD)	RECOMMENDED LUBRICANT AND MANUFACTURER		
List symbols in "Maintenance Operation" (Page 3).	List general lubricant type.	List specific lubricant name, viscosity, and manufacturer.		
RECOMMENDED SPARE PARTS LIST				
PART NO. **	DESCRIPTION	UNIT	QUANTITY	UNIT COST
ADDITIONAL DATA AND REMARKS				
* By Owner ** Identify parts provided by this contract with two asterisks. Note: Attach additional sheets if necessary; identify each sheet at top with equipment number and description.				

END OF SECTION 017823

SECTION 020804 - DUST AND VOLATILE EMISSION CONTROL

PART 1 - GENERAL

1.01 DESCRIPTION

- A. The Contractor shall conduct excavation operations and maintain the Project site in a manner that minimizes the creation and dispersion of dust and limits volatile organic compound (VOC) emissions. Dust control shall be used during the entire Project. VOC emission control shall be used during contaminated soil excavation and handling as directed by the Construction Manager. The Contractor is responsible for control of dust and VOC Emissions at all times during Contract, 24 hours a day, seven (7) days a week, including nonworking hours, weekends, and holidays.
- B. The Contractor shall be responsible for preparing and complying with an area-wide air monitoring program. This responsibility shall include provision of a control system to monitor atmospheric releases and impact on workers and local receptors. Control and monitoring program shall consider contaminants in soil, groundwater and sediment that could be released during work including contaminants at Recognized Environmental Concern (REC) Sites and Known Contaminated Sites (KCS).
- C. Monitor perimeter and exclusion zone air quality in accordance with the Contractor's Air Monitoring Plan to ensure compliance with applicable regulations and requirements.
- D. The purpose of these measures is to minimize the potential exposure of non-Project personnel to airborne contaminants emanating from Project activities.

1.02 PAYMENT

- A. No separate payment shall be made for performing any Work required under this Section. All costs for Work required by this Section shall be included in the applicable lump sum(s), unit price(s), or allowance(s) as set forth in Section 012901.

1.03 RELATED SECTIONS

- A. General Conditions Article 4.7 – Shop Drawings and Other Submittals.
- B. Section 012901 – Measurement and Payment.

1.04 SUBMITTALS

- A. Submit the following in accordance with General Conditions Article 4.7.

- B. Submit an area-wide Air Monitoring Plan for review and approval by the Construction Manager.
- C. Submit a dust control and VOC emission control plan that outlines in detail sources of dust and VOCs and the measures to be implemented by the Contractor to comply with this Section, including suppression, windscreens and barriers, prevention, cleanup, and other measures. Measurement and verification process shall be clearly stated.
- D. Submit photographs of dust and VOC emission control mitigation measures to Construction Manager.

PART 2 - PRODUCTS

2.01 DUST AND VOLATILE EMISSIONS CONTROL

- A. Submit product literature and Material Safety Data Sheets for dust suppression wetting agents and stabilizers and for VOC mitigation materials. This shall be submitted as part of the Dust Control and VOC Emissions Control Plan.
- B. Dust suppression wetting agents shall be water soluble, non-toxic, non-reactive, non-volatile, and non-foaming. Windscreens shall be a durable fabric mesh of 50 percent porosity, attached to a construction fence. Wind barriers shall be solid wood fences, solid durable fabric attached to a construction fence, or other solid barriers intended to block the passage of wind.
- C. Covers for stockpiles shall be plastic tarps or other material covering. Contaminated soil covers are not permitted.
- D. The Contractor shall use the following materials to control VOC emissions at the Project site. All materials shall be applied by the Contractor in accordance with the manufacturer's recommendations.
 - 1. The Contractor shall provide and apply foam concentrate that is designed for and is capable of suppressing VOC emissions at the project site. The Contractor shall submit product information to the Construction Manager for review and approval. This shall be submitted as part of the Dust Control and VOC Emissions Control Plan.
 - 2. The Contractor shall provide foam stabilizer that is designed to extend the duration of effectiveness of the foam concentrate in areas where prolonged emission suppression is required. Foam stabilizer shall not contain per- and polyfluoroalkyl substances (PFAS), perfluorooctanesulfonic acid (PFOS), and/or perfluorononanoic acid (PFNA). The Contractor shall submit product information to the Construction Manager for approval.

PART 3 - EXECUTION

3.01 DUST AND VOLATILE EMISSIONS CONTROL

- A. The Contractor shall apply water or other approved dust suppression materials to the site when dust control is necessary, according to all Federal, State, and local rules, regulations, and guidelines. These materials shall be applied without interfering with excavation equipment or site operations and without creating nuisance conditions such as ponding or runoff.

- B. If VOC emissions, as measured at the perimeter of the site, exceed an action level of ten (10) ppm total VOCs, a temporary foam blanket shall be applied to the source area. Areas where temporary foam may be necessary include the open active excavation, the excavating bucket, and the soil stockpile. The temporary foam shall be capable of suppressing vapors for a period up to twenty-four (24) hours. Permanent foam shall be applied to the open inactive excavation if warranted by VOC levels in exceedance of ten (10) ppm total VOCs. If the ten (10) ppm action level is exceeded, and an open excavation exists at the completion of the workday, permanent foam capable of suppressing vapors for a period more than twenty-four (24) hours shall be applied to the excavation. Foam application shall be made as often as necessary to maintain airborne concentrations below the action level.

END OF SECTION 020804

NO TEXT ON THIS PAGE

SECTION 021600 - EXCESS CLEAN FILL AND CONTAMINATED MATERIALS MANAGEMENT

PART 1 - GENERAL

1.01 DESCRIPTION

- A. It is essential that any contaminated materials, including soil or groundwater, encountered during the Project be handled in a manner that is protective of human health, safety, and the environment and in compliance with Contract Documents and regulatory requirements.
- B. This Section describes procedures for the management of regulated material (contaminated or potentially contaminated soil) that may be encountered throughout the Project Site. The Work shall include the excavation, handling, stockpiling, and reuse of contaminated soil, if encountered.
- C. Dewatering, treatment, sampling, analysis, and the ultimate disposal of contaminated groundwater, if encountered, are under Section 013443.

1.02 PAYMENT

- A. No separate payment shall be made for performing any Work required under this Section. All costs for Work required by this Section shall be included in the applicable lump sum(s), unit price(s), or allowance(s) as set forth in Section 012901.

1.03 REGULATORY REQUIREMENTS

- A. The Contractor shall comply with all Federal, State, and local codes, standards, ordinances, guidance, and permits, including, but not limited to, the following:
 - 1. United States Department of Labor (USDOL) OSHA 29 CFR 1910 General Industry.
 - 2. USDOL OSHA 29 CFR 1926 Safety and Health Regulations for Construction.
 - 3. United States (US) Department of Transportation (DOT) 49 CFR 171-180 and amendments.
 - 4. New Jersey DOT - Updated 2007 Standard Specifications for Road and Bridge Construction.
 - 5. Solid Waste Regulations (NJAC 7:26).
 - 6. Hazardous Waste Regulations (N.J.A.C. 7:26G).

7. Underground Storage Tanks (NJAC 7:14B).
 8. Soil Erosion and Sediment Control Act of 1975 as amended (NJAC 2:90-1.1 et seq.).
- B. The Contractor shall comply with the following if the Work involves handling of contaminated media:
1. Administrative Requirements for the Remediation of Contaminated Sites (N.J.A.C. 7:26C).
 2. Remediation Standards (N.J.A.C. 7:26D).
 3. Technical Requirements for Site Remediation (N.J.A.C. 7:26E).
 4. New Jersey Department of Environmental Protection (NJDEP) - Field Sampling Procedures Manual (August 2005, as updated).
 5. Protocol for Addressing Extractable Petroleum Hydrocarbons (Version 5.0, August 9, 2010).
 6. NJDEP - Historic Fill Material Technical Guidance (April 2013).
 7. NJDEP - Linear Construction Technical Guidance (January 2012).
 8. NJDEP - Fill Material Guidance on SRP Sites (April 2015).
 9. Guidance for the Characterization of Concrete and Clean Material Certification for Recycling (January 12, 2010).
 10. The Standards for Soil Erosion and Sediment Control in New Jersey (Revised July 2017).

1.04 RELATED SECTIONS

- A. General Conditions Article 4.7 – Shop Drawings and Other Submittals.
- B. Section 012901 - Measurement and Payment.
- C. Section 013443 – Environmental Procedures.
- D. Section 014150 – Health and Safety Requirements.
- E. Section 014300 - Quality Requirements.
- F. Section 025100 - Decontamination.

1.05 SUBMITTALS

- A. All submittals shall be in accordance with General Conditions Article 4.7.
- B. Submit a Materials Management Plan as described in Paragraph 3.01 A.4.d. of Section 012901 and Paragraph 1.05.A.3. of Section 013443.

PART 2 - PRODUCTS

Not Used

PART 3 – EXECUTION

3.01 STOCKPILING/STAGING REQUIREMENTS AND PROCEDURES

- A. If the contaminated soil is to be stockpiled, the Contractor shall coordinate with the Construction Manager to determine the best option for the temporary stockpiling/staging of materials. The Contractor shall obtain approval from the Construction Manager prior to moving contaminated soil within the Project Site (away from the immediate work location) for disposal/storage.
- B. Stockpiled materials shall be protected in accordance with any permit issued for this Project, including approved soil erosion and sediment control plans.
 - 1. Place regulated materials in stockpile location. Do not place regulated materials in the same stockpile with any other materials.
 - 2. Stockpiles cannot exceed the dimensions given in the soil erosion and sediment control permit plans.
 - 3. If the materials are left in place more than 30 days, the surface of the stockpile shall be seeded and stabilized.
 - 4. Remove and dispose of all materials that are classified as regulated or hazardous after the Construction Manager approves the submittals.
- C. All proposed stockpile locations (temporary or longer-term) for contaminated material shall be identified on a site plan and presented to the Construction Manager for approval two (2) weeks in advance of stockpiling activities. In the event that materials requiring off-site transportation are generated that have not been fully characterized for waste disposal, the Contractor shall provide in writing to the Construction Manager, the methods to be used for the temporary storage of this material. Once a designated staging area is determined, these soils shall be stockpiled in accordance with the following minimum handling criteria:

1. Excavation, material handling and stockpiling shall be performed in a manner that minimizes the mixing of materials containing different levels and types of contamination in accordance with N.J.A.C. 7:26E-5.2(b).
 2. No re-handling of soils in designated, temporary stockpile storage areas shall be carried out without the approval and presence of the Construction Manager. No material shall be removed without suitable segregation, stockpiling, sampling, testing and characterization and completion of a bill of lading and/or hazardous or non-hazardous waste manifest.
 3. The transfer of all materials from excavation(s) to the designated staging area shall be conducted in such a manner as to not allow the spread of contaminated materials. Transfer of contaminated soils shall be performed in accordance with all applicable waste transportation and management requirements. At a minimum, all soils transported by truck shall be covered to minimize fugitive dust.
 4. Access shall be restricted to authorized personnel only.
- D. Stockpiled contaminated materials shall be placed on an impervious surface lined with polyethylene sheeting (with a minimum thickness of 20 mils) within the designated temporary stockpile storage areas. Excavated material shall be stockpiled. The stockpile will be securely covered with polyethylene sheeting at the end of each workday and maintained throughout the stockpile period to prevent wind dispersion and contact with precipitation. If dust suppression becomes necessary during the soil stockpiling, at the discretion of the Construction Manager, exposed soils shall be wetted.
- E. All material entering or leaving the staging area shall be under the direct supervision of the Contractor. Stockpiles shall be inspected by the Contractor at a minimum of once each week and after every storm event. Inspection results will be recorded in a Daily Log to be maintained at the site and available for inspection by the Construction Manager or designee. A copy of the inspection log will be provided to the Construction Manager with other weekly submittals.
- F. Stockpile areas will be graded to shed water such that storm water runoff is diverted from stockpiled materials and hay bale berms/silt fencing will be placed around the perimeter of the area. Straw bales will be used as needed near catch basins, surface waters and other discharge points. Stockpile slopes will be no steeper than 1 horizontal to 1 vertical (1 to 1).

3.02 EXCAVATED SOIL HANDLING PROCEDURES

- A. Excavated materials from the Project will generally be reused where generated or characterized and disposed at a licensed disposal/ recycling facility. Excavated contaminated soil can be reused on site as backfill material within the linear construction corridor, preferably in the same parcel from which it was excavated,

except when it contains free and/ or residual product. Excavated soils will be inspected by the Construction Manager for visual evidence of free and/ or residual product for instances where soil will be reused as backfill material on site.

- B. Excavated materials from the Project will be characterized and reused on site as backfill material within the same linear construction corridor or disposed at a licensed disposal/recycling facility as per Section 013443.
- C. Contractor shall provide Construction Manager at least two (2) weeks advance notice of moving contaminated soil.

3.03 PROCEDURES FOR HANDLING FREE PRODUCT, IF ENCOUNTERED.

- A. If any soil exhibiting evidence or likelihood of free-product is encountered, the soil shall be removed from the excavation to the extent practical and necessary to complete the proposed work. The petroleum free-product contaminated soil shall be stockpiled separate from other soil. The Contractor shall provide means and methods for management and handling of free product in the case it is encountered.
- B. Soil containing free and/ or residual product must be disposed as per Section 013443.

3.04 BACKFILLING AND CAPPING

- A. Imported backfill material must comply with the NJDEP's April 2015 *Fill Material Guidance for SRP Sites*. The Contractor shall submit the clean fill source and supporting documentation to the Construction Manager prior to the start of construction to demonstrate it meets certified clean fill requirements. All fill materials brought on-site shall comply with current NJDEP Soil Remediation Standards for Residential properties. Alternative fill will not be considered.
- B. Place clean fill materials in stockpile location. Do not place clean fill in the same stockpile with any other materials.
- C. Stockpiles cannot exceed the dimensions given in the soil erosion and sediment control permit plans.
- D. Fill materials
 - 1. Suitable Material: Material from on-site excavation that meets all of the specified requirements for its intended use, but is excess of the amount of material required for the intended use. Wet subgrade material which meets other requirements for suitable material is suitable.
 - 2. Unsuitable Material: Material that fails to meet requirements for suitable materials; or contains any of the following:

- a. Organic clay, organic silt, or peat as defined in ASTM D2487.
- b. Vegetation, wood, roots, leaves, and organic, degradable material.
- c. Stones or rock fragments over 6 inches in any dimension.
- d. Porous biodegradable matter, excavated pavement, construction debris, rubbish, or refuse.
- e. Ice, snow, frost, or frozen soil particles.
- f. Alternative Fill, as defined by NJDEP Fill Material Guidance for SRP Sites (2015).

3.05 DECONTAMINATION PROCEDURES

- A. The Contractor will designate an area for implementing decontamination procedures (e.g., steam cleaning, manual scrubbing, etc.) for all equipment contacting contaminated material in accordance with Section 025100. In addition, all roads in the construction area will be swept to keep the roadway free of dirt and debris. Recovered wastes resulting from decontamination shall be properly characterized, transported and disposed off-site in accordance with applicable federal, State, and local requirements and Section 013443.

END OF SECTION 021600

SECTION 023214 - VIBRATION AND NOISE MONITORING

PART 1 - GENERAL

1.01 DESCRIPTION

- A. This specifies requirements for furnishing all labor, materials, equipment to perform all activities related to vibration and noise monitoring as specified here in.
1. Vibration monitoring associated with the installation of earthwork and/or installation of piles, pipes and sheet piles.
 2. Provide vibration monitoring during vibration inducing construction activities within 150 feet of any structure. The Contractor shall provide seismographs at locations determined in the vibration monitoring plan as approved by the Construction Manager.
 3. Furnish, install, maintain, monitor, and remove vibration monitoring equipment as specified herein.
 4. Monitor vibrations and noise levels originating from construction activities as indicated herein.
 5. Modify construction operation procedures if existing operation creates vibration or noise exceedances as specified herein.
 6. Provide noise monitoring during all construction activities.
 7. Furnish, install, maintain, monitor, and remove noise monitoring equipment as specified herein.
 8. Vibration control for historic structures.

1.02 PAYMENT

- A. No separate payment shall be made for performing any Work required under this Section. All costs for Work required by this Section shall be included in the applicable lump sum(s), unit price(s), or allowance(s) as set forth in Section 012901.

1.03 REFERENCES

- A. Unless otherwise noted, the latest edition of the following codes and standards shall govern this work. If any conflicts exist between these codes and standards the more restrictive requirements shall govern.
- B. American Society for Testing and Materials International (ASTM)

1. ASTM E90: Standard Test Method for Laboratory Measurement of Air-borne Sound Transmission Loss of Building Partitions and Elements.
 2. ASTM C423: Standard Test Methods for Sound Absorption and Sound Absorption Coefficients by the Reverberation Room Method.
- C. Federal Highway Administration (FHWA), FHWA-HEP-06-02: Construction Noise Handbook.

1.04 RELATED SECTIONS

- A. General Conditions 4.7 – Shop Drawings and Other Submittals.
- B. Section 012901 – Measurement and Payment.
- C. Section 014300 - Quality Requirements.
- D. Section 016100 – Control of Materials
- E. Section 017423 - Cleaning Up.
- F. Section 017700 - Contract Closeout.
- G. Section 310930 – Geotechnical Instrumentation

1.05 SUBMITTALS

- A. Submit the following qualifications in accordance with General Conditions 4.7.
 1. Submit the following qualifications four (4) weeks prior to the start of any construction activities.
 - a. Qualifications of the Contractor’s vibration consulting firm, as specified in Paragraph 1.06.C.
 - b. Qualifications of the Contractor’s Acoustical Engineer, as specified in Paragraph 1.06.C.
 - c. Qualifications of the Contractor’s Engineering Technician, as specified in Paragraph 1.06.D.
- B. At least five (5) weeks prior to the start of any construction activities provide Vibration and Noise Monitoring Plans, prepared by the Vibration consulting firm and/or the Acoustical Engineer, and installation details specified herein. This shall include but not limited to the following:

1. Drawings showing the layout and locations of instruments, including wire diagrams for power and/or communications. Power lines carrying 110 volts or more shall be enclosed in conduits of the size and materials required by the NEC.
2. The scheduled start date and length of construction activities which require vibration and noise monitoring.
3. Instrument identification numbers.
4. Details of supports, fixtures, etc. required for installation of instruments and associated systems.
5. The location of any underground utilities in proximity to the construction operation.
6. Proposed construction method(s). The duration and type of equipment to be used during construction and an explanation of how the vibrations will be maintained at an acceptable level.
 - a. Identify equipment location and processes.
7. Identification of the zones of potential construction influence for vibrations and noise.
8. Vibration and noise sensitive buildings near the Project. Location of historic structures and associated construction zones as indicated in Table 1.05-1 Previously Identified Historic Architectural Resources in Resist Construction Zone.
9. Vibration Calculations: Prepare calculations of maximum peak particle velocity vibration level expected at the nearest residential, commercial, and all other structures and railways.
10. Noise Calculations: prepare calculations of one-hour L_{eq} noise levels expected at the nearest residential and commercial buildings.
11. Update the Vibration and Noise Monitoring plans at least in three (3) month intervals from the initial acceptance date.
12. Vibration and Noise reduction Methods: To the extent required to meet the ground vibration peak particle velocity, ground-borne noise (interior) limits, and airborne (exterior) noise limits specified herein, modify construction operations to reduce vibration and noise.
13. Manufacturers materials and equipment data sheets.
14. Design of noise mitigation strategies, methods, procedures, and technology and locations and types of noise reduction measures that may be required.

15. Location of noise sensitive locations and any specified measures to be undertaken to minimize the impact of work on these locations.

TABLE 1.05-1 PREVIOUSLY IDENTIFIED HISTORIC ARCHITECTURAL RESOURCES IN RESIST CONSTRUCTION ZONE

ID NO.	RESOURCE NAME	LOCATION	DIRECT EFFECTS
4.	Engine Company #2 Firehouse (Thematic Nomination of Hoboken Firehouses)	1313 WASHINGTON STREET	Potential Adverse Effect Due to Vibration During Construction of Resist Structure
8.	Hoboken Historic District/ Observer Highway	14TH, CLINTON, 8TH, MONROE, 1ST, AND BLOOMFIELD STREETS	Potential Adverse Effect to Contributing Resources in Historic District Due to Vibration During Construction of Resist Structure
10.	Hoboken-North Hudson YMCA	1301 WASHINGTON STREET	Potential Adverse Effect Due to Vibration During Construction
13.	Old Main Delaware, Lackawanna and Western Railroad Historic District	Morris & Essex Railroad Right-of-Way to Delaware River	Potential Adverse Effect to Contributing Resources in Historic District Due to Vibration During Construction of Resist Structure
16.	Hudson and Manhattan Railroad Transit System (PATH) Hoboken and Jersey City	PATH connects Exchange Place and Hoboken to New York City	Potential Adverse Effect Due to Vibration During Construction
17.	Grove Street Bridge	NJ Transit Morristown Line, M.P. 0.66 over Grove Street	Potential Adverse Effect Due to Vibration During Construction
21.	R. Neumann & Co. Complex	300 Observer Highway	Potential Adverse Effect Due to Vibration During Construction

Note: The historic resources are identified by the number provided in the Programmatic Agreement among the New Jersey Department of Community Affairs, the Advisory Council

on Historic Preservation and the New Jersey Historic Preservation Office regarding the Rebuild By Design-Hudson River Project in Hudson County, NJ (September 2017).”

- C. Provide vibration and noise measurement equipment calibration certificates for equipment used on site by the Contractor.
- D. The procedure for tracking peak particle velocity throughout construction activities (e.g., Pile Driving Operations: pile tip vs. vibrations may be correlated through time of day. A record of the time of day at each depth interval, included on the pile driving records, would be required to correlate to a time-based readout of peak particle velocity).
- E. Equipment Sound Level Data Reporting Form for each item of construction equipment to be used.
- F. Laboratory calibration conformance certificate for all noise measuring equipment used by the Contractor prior to performing any noise level monitoring. Submit updated certificates following subsequent yearly calibrations, or upon completion of repairs to the instrument, for the duration of the Contract.
- G. Manufacturers’ Certificate of Compliance that equipment is noise attenuated.
- H. Daily reports, while performing vibration-inducing operations, detailing each source of vibration, location of monitoring, and the vibration records highlighting peak particle velocities. All daily reports shall be stamped and signed by the Vibration Consulting Firm's Professional Engineer and provided within 24 hours of the end of each day’s activities indicating a site plan drawing showing the location of the instrument and maximum and average vibration recorded during the workday period.
- I. The Contractor shall submit a final report summarizing the collected data upon completion of each construction operation.
- J. Submittal and reporting requirements for historic structures are summarized below in Section 3.11.

1.06 QUALITY ASSURANCE

- A. Provide in accordance with Section 014300.
- B. The Contractor’s or Contractor’s Vibration consultant and/or Acoustical Engineer, responsible for furnishing and installing all vibration and noise instruments, including all equipment specified here in, maintaining the instruments, as required, and interpreting all data provided or collected shall have the qualifications specified here in. The personnel may be employed by the contractor or may be employed by a specialized consulting firm.
- C. Vibration and/or Acoustical Engineer Qualifications:

1. A State of New Jersey Licensed Professional Engineer responsible for designing and monitoring vibration and noise specified here in and interpretation of the data.
2. Not less than six (6) years' experience in the installation and monitoring of the vibration and noise instrumentation specified here in.
3. Completed not less than five (5) successful vibration and noise installation and monitoring projects of similar scope and magnitude within the past ten (10) years.
4. Shall be onsite to supervise and conduct the pre/post installations of each type of instrumentation. The qualified engineer shall be onsite and supervise the first five (5) installations of each type of instrument, shall oversee and establish the formal initial readings, shall oversee interpretation of all collected and provide vibration and noise data.

D. Engineering Technician Qualifications:

1. To be responsible full-time on site during the implementation of the vibration and noise monitoring plan.
2. Not less than three (3) years of direct field experience in the installation and monitoring of the types of vibration and noise instruments specified herein and have supervised vibration and noise monitoring programs of a similar scope and magnitude with similar work conditions.
3. Shall be available to supervise all instrument installations, establish initial readings, collect baseline data, and vibration and noise data when the acoustical engineer is not present on-site.

1.07 DELIVERY, STORAGE, AND HANDLING

- A. Comply with requirements specified in Section 016100.

1.08 SITE CONDITIONS

- A. Geotechnical Investigation Results Report (Final – April 2021): The report is for information only, which is part of the Contract Documents. The boring logs are included as an appendix in the report and indicate subsurface conditions encountered only at the borehole location. This report shall not be construed as to guarantee that other subsurface materials will not be present or that proportions of materials will not vary from that shown on the boring logs. The borehole locations and soil profiles are part of the Contract Drawings.

PART 2 - PRODUCTS

2.01 EQUIPMENT

- A. Seismographs shall be “Minimate Pro4” manufactured by InstanTel Inc., Geometrics, Inc., Nomis Seismographs, LLC or approved equal, and shall have the following minimum features:
1. Seismic Range: 0.01 to 10 inches per second with an accuracy of plus or minus 5-percent of measured peak particle velocity or better at frequencies between 4 and 125 Hertz, and with a resolution of 0.001 inch per second or less.
 2. Acoustic Range: 88 to 148 dB (L) with an accuracy and resolution of plus or minus 1 decibel.
 3. Frequency Response (plus or minus 3 decibel points) 2 to 250 Hertz.
 4. Three Channels for vibration monitoring plus a fourth channel for linear or sound level microphone.
 5. Two power sources: Internal rechargeable battery and a charger and 115 volts ac. Battery must be capable of supplying power to monitor vibrations continuously for up to 24 hours.
 6. Capable of internal dynamic calibration.
 7. Computer software to perform analysis, produce reports of continuous monitoring, and to perform zero-crossing frequency analyses of waveform data on magnetic disks.
 8. Self-triggering waveforms capture mode that provides the following information: plot of waveforms, peak particle velocities, and frequency peaks.
 9. Continuous monitoring mode capable of recording events up to 10 seconds long, and histogram mode to record events continuously.
 10. All geophones shall be external to the seismograph to allow solid bolting or anchoring to surfaces with “Red Head” anchors, Dewalt Inc. Anchors, MITEK, Inc., or approved equal.
 11. Crack displacement gauges: Install crack displacement monitoring gauges across structural cracks identified in the preconstruction survey. Monitor firm to provide real-time crack gauge monitoring of the historic property(s) during demolition, excavation, and construction operations.
- B. Sound Level Meters provided by the Contractor shall comply with the requirements of the current revision of ANSI S1.4, Type 2 (Precision) Sound Level Meters (SLM). SLM

to be capable of measuring the L_{max} and ten minutes to one-hour L_{eq} on the A-weighted scale required by for ground borne noise level limits.

2.02 NOISE CONTROL MATERIALS

- A. Noise control materials may be new or used. Used materials shall be sound and free of damage and defects and shall be of quality and condition to perform their design function. All equipment and materials specified herein will remain the property of the Contractor or Contractor's subcontractors, vendors, and suppliers, as applicable.
- B. All construction equipment shall incorporate the latest noise attenuation features available to the manufacturer.
- C. Acoustical materials and curtains shall have a Sound Transmission Class (STC) rating of STC 30 or greater, based on sound transmission loss data according to ASTM E90. The noise absorption face of the curtain shall have a Noise Reduction Coefficient (NRC) rating of 0.85 or greater, based on sound absorption coefficient data taken according to ASTM C423.

PART 3 - EXECUTION

3.01 GENERAL REQUIREMENTS

- A. Provide access to instrument locations and maintain instrument locations from damage.
- B. Perform Work within the permissible noise and vibration levels, Work Schedule limitations, and procedures provided herein, and applicable Federal, State, County, and Municipal codes, regulations, and standards.
- C. The property owners for any and all structures to be monitored for vibration with seismographs shall be notified in writing two (2) weeks in advance of any work and prior to accessing any property to install equipment.
- D. No vibration producing construction activities may be started until the appropriate instrumentation is provided by the Contractor and approved by the Construction Manager.
- E. Other than those provided as part of the Contract, the Contractor is responsible for obtaining permits, variances, equipment certifications, and other documents required.
- F. Modify vibration and noise control measures based on results of the vibration and noise measurements undertaken and any reported nuisance conditions, define operational and/or equipment restrictions.
- G. The Construction Manager may issue a Stop Work notice if the vibration and noise level limits set herein are exceeded and cannot be mitigated.

3.02 VIBRATION AND NOISE MONITORING

- A. Furnish specified instruments to be installed, operated and interpreted by the vibration consulting firm and/or Acoustical Engineer's personnel, as specified herein and indicated.
- B. Noise monitoring stations shall be installed in three (3) locations in each Work area throughout the Project.
- C. Take initial background readings of all noise stations for a one-week period prior to the start of construction activity in the area.
- D. Take initial background readings at all seismograph locations for three days prior to the start of construction activities in the area.
- E. Perform all vibration-inducing operations so that vibrations reaching adjacent structures and facilities are within specified limits.
- F. All vibration and noise reporting shall comply with Section 310930 or as specified herein.

3.03 DATA REDUCTION, PROCESSING, PLOTTING, AND REPORTING

- A. The Contractor shall be responsible for the reduction, processing, plotting, and reporting of data collected from the instrumentation installed.
- B. The Contractor shall be responsible for reviewing the data in real-time and/or daily and immediately inform the Construction Manager of any exceedances to the response limits.
- C. The Contractor shall be responsible for providing weekly reports, including all instruments that are located within active construction zones.
- D. When the Construction Manager determines from the data, provided by the Contractor, that a change or trend is apparent, that while not exceeding the vibration and/or noise limits specified, precautionary measures may be taken. The Construction Manager will notify the Contractor in order to verify the data trends and take appropriate action in accordance with the approved Instrumentation Monitoring Plan.
- E. Where data provided to the Construction Manager from the Contractor, indicating an exceedance in the vibration and/or noise limit, all construction activities shall stop, and the actions indicated in the Vibration and Noise Monitoring Plan shall be implemented.
- F. None of the above shall relieve the Contractor of responsibility for the safety of the work.

3.04 VIBRATION LEVEL LIMITS

A. Vibration level limits measured in peak particle velocity (PPV), defined as the maximum of the ground motion velocities measured in the vertical, longitudinal, and transverse directions measured in inches per second (in/s), for construction activities and operations of temporary systems shall be follows:

1. New Construction:

a. The maximum PPV level limits, in any direction, for all new concrete construction shall not exceed the table below measured by a portable seismograph place adjacent to the new construction at the closest point to the vibration source. The maximum permissible PPV shall be reduced if damage is detected. It is assumed that the vibration-inducing construction activity shall have an influence zone of 100 feet radius when considering the protection of new construction.

<u>Type of Concrete</u>	<u>Age of concrete (hours)</u>	<u>Peak Particle Velocity</u> <u>in./sec</u>
Mass Concrete (footings, mats, slab-on-grade, fill concrete, etc.)	0-10	1.0
	11 and over	2.0
Concrete Structures (walls, columns, elevated slabs, etc.)	0-11	0.5
	11-24	1.0
	24 and over	2.0

2. Building and above ground structures:

a. The maximum PPV level limits, in any direction, for all construction activities at historical buildings, as indicated in the Contract documents, shall not exceed 0.12 in/s as measured by a portable seismograph place adjacent to or within the historical building at the location closest to the vibration source. The maximum permissible PPV shall be reduced if movement or cracking is detected or if the pre-construction survey identifies a historic building with a lower PPV should be imposed. It is assumed that the vibration-inducing construction activity shall have an influence zone of 150 feet radius when considering the protection of historic buildings. Monitoring of vibrations at such buildings shall be undertaken for the duration of construction activities that will influence the structure.

b. The maximum PPV level limits, in any direction, for all construction activities at buildings and structures other than historical buildings shall not exceed 1.9 in/s as measured by a portable seismograph place adjacent to or within the building or structure at the location closest to the vibration source. The maximum permissible PPV shall be reduced if movement or cracking is

detected or if the pre-construction survey identifies a building or structure with a lower PPV should be imposed. It is assumed that the vibration-inducing construction activity shall have an influence zone of 150 feet radius when considering the protection of buildings and structures. Monitoring of vibrations at such structures shall be undertaken for the duration of construction activities that will influence the structure.

3. PATH Tunnels, HBLR and NJT structures and facilities: The maximum PPV level limits in any direction, for all construction activities shall not exceed 1.0 in/s above the existing ambient vibrations levels in these structures as measured by the Contractor during background readings.

- B. In the event any data indicates that vibration level limits are being exceeded, immediately suspend all vibration-inducing operations and submit a report to the Construction Manager. Revise operations to reduce vibrations and submit a copy of the revised procedure to the Construction Manager at no additional cost to the NJDEP.
- C. If evidence of displacement or damage to utilities, equipment, or structures is observed or reported, immediately notify the Construction Manager and Stop Work in the area. Revise operation to reduce vibrations and submit a copy of the revised procedure to the Construction Manager.
- D. Restore or replace utilities, equipment, or structures damaged by vibrations at no additional cost to the NJDEP.

3.05 GROUND-BORNE NOISE

- A. Ground-borne noise levels within buildings structures due to construction activities, specifically pile driving, is limited to L_{eq} noise levels, a measured over a 10-minute period, listed in the table below.
- B. The ground-borne noise will be measured at the interior of the nearest occupied building to the construction activity. Measurements shall be conducted once a day during both daytime and nighttime (when applicable) hours to measure ground-borne noise levels at the building location from the construction activities. Noise measurements shall also be conducted at the closest occupied level of the nearest building to the construction activities as specified herein. The ground-borne noise level limits will be adjusted to ambient plus 5 dBA at those locations where the interior background noise levels are higher than the levels listed in the table below.

Ground-Borne Noise Level Limits – L _{eq} (dBA)		
Category of Land Use	Daytime (8 am to 10 pm)	Nighttime (10 pm to 8 am)
Residential	55 dBA	40 dBA
Hotel	5 dBA	45 dBA
Offices	55 dBA	n/a
Commercial spaces	60 dBA	n/a

3.06 AIR-BORNE NOISE LEVEL LIMITS

- A. Noise levels for public exposure shall comply with the following noise level restrictions in all areas:
 1. In no case expose the public to construction noise levels exceeding 90 dBA on “slow” response or impulsive noise level exceeding 125 dBA maximum transient level “fast” response as measured on a general purpose sound level meter.
 2. Conduct construction activities in such a manner that the noise levels 200 feet from the Work area or the nearest affected building, whichever is closer, do not exceed the levels listed in the table below.
 3. In areas outside of the Work area and not designated as a special zone, prevent stationary noise sources, parked mobile sources or any other source or combination of sources from producing repetitively scheduled or long-term noise lasting more than 10 percent of the construction duration from exceeding the limit in the table below.
- B. Test the equipment and demonstrate compliance with noise limits specified herein.
- C. Perform the work in a manner to minimize nuisance conditions such as noise that exhibits a specific audible frequency or tone (e.g., back-up alarms, unmaintained equipment, and brake squeal) or impact noise.

Construction Noise Limits		
Land Use	Noise Level – L_{eq} (dBA) (whichever is greater)	L_{max} Level (dBA, slow)
Daytime (8 am to 5 PM)		
Residence and building where people normally sleep	75 or Background +5	85 90 (impact equipment)
Commercial Spaces	80 or Background +5	None
Industrial Spaces	80 or Background +5	None
Evening (5 pm to 10 pm)		
Residence and building where people normally sleep	65 or Background +5	85
Commercial Spaces	80 or Background +5	None
Industrial Spaces	80 or Background +5	None
Nighttime (10 pm to 8 am)		
Residence and building where people normally sleep	Background +5 (if <70 dBA) Background +3 (if > 70 dBA)	80 80
Commercial Spaces	None	None
Industrial Spaces	None	None

Notes:

- Noise from impact equipment is exempt from the L_{eq} requirement, however, is subject to a lot-line L_{max} limit of 90 dBA
- All measurements will be taken at the effective lot-line in accordance to what is stated herein.

3. Noise level limits are averaged over 20-minute intervals
4. L_{max} noise level limits are the maximum noise level that occurs over a 20-minute period.

3.07 EQUIPMENT NOISE CERTIFICATION

A. Requirements for Construction Equipment:

1. Ensure the Contractor and subcontractor construction equipment used in the Work area is tested for compliance with state noise emission limits during the first day of use on the Project, with compliance data provided to the Construction Manager for review.
2. Retest equipment at six-month intervals while in use in the Work Area, and certify new equipment before being placed into service at the Work area.
3. For each piece of equipment used, provide an Application for Certificate of Equipment Noise Compliance. Ensure that the equipment identification number used for the Certificates is consistent with the identification number used in the Noise Monitoring Plan. Do not use equipment onsite without valid Certificates of noise Compliance. The Certificates at a minimum shall have the following information:
 - a. Contractor Name
 - b. Contract name and number
 - c. Equipment type, manufacturer, and model number
 - d. Identification number
 - e. Rated power & capacity
 - f. Operating condition during test
 - g. Measured noise level at 20 to 50 feet from equipment on both the left and right sides
 - h. Maximum allowable noise level for equipment based on FHWA-HEP-06-02.
 - i. Authorized signature from the Contractor.

B. Test Procedures for Construction Equipment:

1. Operate engine powered equipment by Contractor at maximum governed rpm under full load conditions during tests.

2. Test portable and mounted impact hammers, such as hoes rams, jackhammers, to be used for concrete breaking, during first day of actual operation at the Work area under maximum load conditions as rated by the equipment manufacture.
3. Noise Certification Measurement: Use an acoustic calibrator of the type recommended by the sound level meter manufacturer before measurements.
4. As specified herein, take measures at two locations: two from the right and left sides of the equipment, at a distance of 50 feet and a height of five feet above ground level, with equipment operating at maximum governed rpm under full load conditions for a minimum period of one minute. Reduce noise measurements made at less than 50 feet, due to space limitations at test location by the values in the following table:

Adjustments for Close-In Equipment Noise Measurements	
Distance (feet)	Measured Values to be Subtracted from Measured Noise Level to Estimate Sound Level at 50 feet (dBA)
19-21	8
22-23	7
24-26	6
27-29	5
30-33	4
34-37	3
38-42	2
43-47	1
48-50	0

C. Noise Certificate Compliance:

1. Complete and maintain a noise report for each piece of equipment used with certification that the equipment noise emissions does not exceed those prescribed in FHWA-HEP-06-02.

2. If noise levels obtained during tests exceed those specified in FHWA-HEP-06-02, remove such equipment from use until equipment is modified and retested, or substitute other equipment to meet the noise level requirements.
3. Equipment will be subject to spot noise level testing at the Construction Manager's discretion to determine that the equipment in use meets the requirements specified herein.

3.08 LOSS OR DAMAGE TO INSTRUMENTS

- A. Follow procedures in accordance with Section 310930.

3.09 DISCLOSURE OF DATA

- A. Follow procedures in accordance with Section 310930.

3.10 DISPOSAL OF INSTRUMENTS

- A. Follow procedures in accordance with Section 310930.

3.11 CONTRACT CLOSEOUT

- A. Provide in accordance with Section 017700.

3.12 HISTORIC RESOURCE CONSTRUCTION PROTECTION PLAN

A. PRECONSTRUCTION DOCUMENTATION AND ACTIVITIES

1. Contractor shall notify existing property owners of historic properties of that inspections of their property are required to facilitate the preconstruction inspection process. Said notification should inform owners of the scheduled time for the inspection of their property, be distributed in a timely manner to allow for comment and include the contact information of the appropriate Project Team member.
2. Contractor shall perform a preconstruction inspection of each potentially affected historic property(s) listed in Table 1.05-1 undertaken by a third-party professional engineer(s) licensed to practice in the State of New Jersey (the "Inspecting Engineer"), to ascertain all pre-existing damage, existing structural distress, and any potential weakness of the historic property'(s) foundations or structures. The Inspecting Engineer must meet the approval of the NJDEP's professional archaeologist (Archaeologist/WSP).
 - a. The pre-construction surveys will include all interior floors and basements and a complete exterior survey. Installation of exterior crack monitors (real-time) shall be placed on readily accessible existing exterior cracks greater than 2 mm (0.08 inch) in width with the consent of the property owner.

Readily accessible shall mean up to 7 feet from the sidewalk or adjacent to a fire escape or balcony within arm's reach.

- b. The location of all cracks greater than 2 mm (0.08 inch) in aperture width shall be recorded with a positional accuracy of +/- 2 ft. Installation of grid crack monitors may be required on selected readily accessible cracks with an aperture width greater than 2 mm (0.08 inch).
 - c. Use a professional (non-digital) camera to take photographs of the interior, exterior, or other areas using appropriate lenses capable of producing archival negatives and prints. Interior details and subsurface photographs may be taken using a professional grade camera with appropriate lenses capable of producing archival 35 mm negatives.
3. The Inspection Engineer shall produce a written report that documents all potential weakness or structural distress, assesses the stability of any applied ornament and exterior architectural features, together with a protocol addressing any recommended remediation to secure problem areas prior to the commencement of any construction activities that may affect the historic property(s).
- a. Individual Property Reports shall be prepared for all historic property(s) where a pre-construction survey was performed. The written report will be supplemented with photographic documentation in the form of 8-inch x 10-inch black-and-white photographs keyed to a map or plan in order to provide a concise record of the existing condition of the structure and any potential problems that appear evident. All photographs shall contain the project record identification number and date and time of exposure, printed integrally during processing.
 - b. The technical report shall be carefully and objectively written outlining the history, occupancy, type of construction, materials and other pertinent details of the structure. In the report adequately and logically detail all evidence of structural and non-structural distress, covering framing, exteriors, interiors, roof, basement interiors, details and ornaments/features, sidewalks and curbs and other elements of the structure, which have been surveyed. Include sketches as necessary.
 - c. Submit the pre-construction survey report to the NJDEP for review and retention. Upon request, the reports shall also be given to the owner of the historic property surveyed and any subcontractor who may cause potentially adverse vibrations during construction.
 - d. The NJDEP shall submit the pre-construction survey report for review by the State Historic Preservation Office (SHPO).

4. Contractor shall install crack displacement monitoring and vibration control equipment prior to construction to record initial readings and gather baseline data. Preconstruction crack and vibration readings provide a reference data set (or ambient in the case of vibration and noise) from which future readings can be compared. All of the installed instrumentation will use real-time monitoring capabilities to transmit information regarding the movement, settlement, tilt, strain and induced vibration of the historic property(s) as a result of the Project's excavation, construction or tunneling. The purpose of monitoring instrumentation (i.e. seismograph, crack gauges) is to measure any induced or excessive movements as a result of tunneling, excavation and construction activities which may have the potential of causing an adverse effect on the historic property(s).
 - a. Install crack displacement monitoring gauges across structural cracks identified the preconstruction survey.
 - b. Install seismographs in the basement and/or the first floor of the historic property(s) or other locations deemed most beneficial for readings. Locate the units discreetly away from the public but accessible to the monitoring technician responsible for management of their readings. Seismographs measure vibration levels during demolition, excavation, and construction.
 - c. **SPECIAL PROVISION:** Based on the pre-construction survey reports, additional geotechnical and structural instrumentation shall be installed on surfaces of, or nearby to, the identified historic property(s) for particularly sensitive historic properties or those with a high "importance factor." The installation of additional equipment may require owner's consent, especially if it must be installed inside or on the exterior of the historic property(s).

The purpose of additional geotechnical and/or structural control instrumentation is to measure any movement, settlement, tilt, and strain that may be caused by excessive vibration and may also be a result of tunneling, excavation and construction activities. Movement of any type caused by numerous reasons may have the potential of causing an adverse effect on the historic property(s).

5. Program the vibration monitoring equipment to trigger a system alert upon the detection of a critical movement level readings. Most vibration control equipment is designed to provide an alert (i.e., sonic alarm, system alert within the monitoring program) upon the detection of a review or alert level reading. See Section 3.12 B.1. below for the recommended critical movement level thresholds.

B. VIBRATION CONTROL DURING CONSTRUCTION

1. The vibration limits for each historic property within the construction zones shall adhere to the limits specified in Section 3.04 A.2.a. The criteria adhere to the APT recommended range for the vibration control threshold, which limits construction

vibration to a PPV range of 0.12 in/sec. More stringent vibration criteria may be adopted for specific historic structures, based upon the findings of the preconstruction surveys. These limits will be adhered to and monitored during construction to aid in the preservation of the historic property(s).

Monitor firm (retained by the Construction Contractor) will thereafter ensure that the appropriate vibration limits and any other criteria deemed appropriate by the Archaeologist/WSP are administered during construction. The Monitor firm is responsible that equipment is in working condition at all times and/or the replacement of faulty equipment. Monitor firm will be responsible for monitoring these controls, with oversight provided by the Construction Management team (CMF) and with periodic inspection by Archaeologist/WSP.

- a. Review and Alert Levels with respect to different types of movement.

Table 3.12-1: Review and Alert Levels for Various Movement







Type of Movement	Response Level	
	Review	ALERT
Shifting	0.125 in.	0.25 in.
Settlement	0.125 in.	0.25 in.
Tilt	1:500	1:250
Vibration (PPV)	> 0.50 in/sec	> 0.12 in/sec

- b. Report Critical Level Readings with respect to the different types of movement. The flowchart below outlines the steps in the event of a critical level monitor reading (see Figure 1). If damage is sustained, refer to the structural damage categories outlined in Table 3.12-2 when describing the level of damage observed after the critical level reading.

Table 3.12-2: Damage Categories to Determine Damage Sustained by Historic Structures

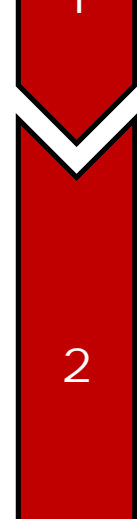
Damage Category	Damage Sustained
1 Cosmetic	The formation of hairline cracks on drywall surfaces or the growth of existing cracks in plaster or drywall surfaces; formation of hairline cracks in mortar joints of brick/concrete blocks.
2 Minor	The formation of large cracks or loosening and falling of plaster or drywall surfaces, or cracks through bricks/concrete blocks.
3 Major	Damage to structural elements of the building, cracks in support columns, loosening of joints, splaying of masonry cracks, etc.

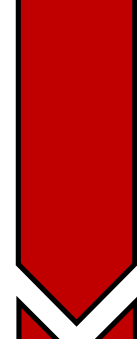
Figure 1: Response Level Actions due to Critical Level Reading

REVIEW LEVEL READING	ALERT LEVEL READING
 <ul style="list-style-type: none"> – Monitor firm must notify the Project Team and the NJDEP/SHPO of the Review Level reading.¹ 	 <ul style="list-style-type: none"> – Monitor firm must notify the Project Team and the NJDEP/SHPO of the Alert Level reading.
 <ul style="list-style-type: none"> – Inspect the historic property(s) for damage. Refer to the preconstruction baseline data to substantiate observations. – If damage is evident, refer to the Alert Level, Step 2 response procedures. – If no damage is evident, within 8 hours submit a report detailing the site conditions that resulted in a Review Level reading, document no damage and include a specific plan of action to avoid future Review Level readings. Submit the report to AECOM, CMF, and NJDEP/SHPO for a prioritized review. 	 <ul style="list-style-type: none"> – AECOM and/or CMF must perform a site inspection with the Inspection Engineer who performed the preconstruction inspections. – Inspect the historic property(s) for damage. Refer to the preconstruction baseline data to substantiate observations. – If no damage is evident, within 8 hours submit a report detailing the site conditions that resulted in an Alert Level reading, document no damage and include a specific plan of action to avoid future Alert Level readings. Submit report to AECOM, CMF and NJDEP for review.
 <ul style="list-style-type: none"> – After prioritized report review, AECOM and the NJDEP/SHPO will make any necessary recommendations to the plan of action and determine if/when construction activities can resume. – Upon approval to resume construction activities, Monitoring firm must adhere to the plan of action to avoid future Review Level readings. 	 <ul style="list-style-type: none"> – If damage is evident, within 12 hours submit a detailed report detailing the site conditions that resulted in an Alert Level reading, document the property damage and include a specific plan of action to avoid future Alert Level readings. Submit the report to AECOM, CMF, and NJDEP/SHPO for a prioritized review.⁵
 <ul style="list-style-type: none"> – Install additional instruments if directed by the Project Team and/or NJDEP/SHPO. 	 <ul style="list-style-type: none"> – After prioritized report review, AECOM, CMF, and the NJDEP/SHPO will make any necessary recommendations to the plan of action and determine if/when construction activities can resume. – Upon approval to resume construction activities, Monitoring firm must adhere to the plan of action to avoid future Review Level readings. – Install additional instruments if directed by the Project Team and/or NJDEP/SHPO.

¹ Prioritized SHPO review due to critical level readings will aid in the timely stabilization of impacted historic buildings and help reduce excessive stop time that may adversely delay a construction schedule.

Response Level Action Plan, If a historic property(s) sustains any damage as a result of an exceedance, the historic property(s) will be secured and the work that caused any damage will be altered to reduce the vibration, movement, settlement and/or tilt levels to within acceptable limits as approved by the Archaeologist/WSP assuming acceptable limits do not cause further damage. If acceptable limits cause further damage to the historic property(s), a special provision specific to that property will need to be executed by the Contractor as directed by the Archaeologist/WSP. Following the corrective measure to ensure that the vibration, movement, settlement and/or tilt levels are reduced and/or cause no further damage, construction may resume. This effort outlined above requires the coordination of the entire Project Team (Contractor, Archaeologist/WSP, CMF, NJDEP).

2. In the event of a response level reading due to excessive movement, settlement, tilt and/or vibration, the Contractor shall immediately stop all activity. Monitor firm will determine if said movement, settlement, tilt, and/or vibration requires a review or an alert level response action outlined in Section 3.11 B. 1.b.
3. Perform continuous real-time vibration and crack gauge monitoring. Under supervision of CMF, Monitoring firm will provide continuous real-time vibration and crack gauge monitoring of the historic property(s) pursuant to Section 3.12 during demolition, excavation, and construction operations. NJDEP through their consultant(s) may perform offsite readings or on-site visits to review the real-time monitoring data to ensure that movement levels remain below the established thresholds during demolition, excavation, and construction.
4. Maintain daily logs of all monitoring equipment. Monitoring data shall be subject to review at any time by the on-site contractor and/or the Archaeologist/WSP, the CMF, and NJDEP through their consultant(s). Property owners may also obtain a copy of monitoring reports upon request. The Archaeologist/WSP, CMF, and NJDEP will have the capabilities of reviewing the data remotely or on site. Identify the construction equipment and their locations in relation to monitoring equipment.
5. Submit weekly monitoring readings to the NJDEP. Upon written request, the NJDEP and/or the SHPO may request a copy of interim readings. Monitoring firm shall submit monitoring logs to the NJDEP on a monthly basis for their review or by the SHPO upon written request.

C. DAMAGE REPAIRS

1. Repairs to the historic property(s) required as a result of construction activities are at the expense of the Contractor. The preconstruction inspection reports performed by the Inspection Engineer, which shall be included in the Vibration and Noise Monitoring Plan, will assist in substantiating repairs and processing claims for sustained damages. Substantiated repairs shall be to pre-construction condition and performed in a timely manner. Required work shall be detailed and administered under separate contract between the property owner and the Contractor.

2. All repairs to the historic property(s) identified in this HRCPP must be in compliance with the Secretary of the Interior’s Standards for Rehabilitation and/or if damages adversely impacted character-defining architectural features of a historic property(s). All repairs will be completed in consultation with the SHPO.

D. REQUIRED DOCUMENTATION

1. Pre-construction Report
 - a. Prior to Construction, a third-party reviewer shall conduct photo-documentation of existing conditions for the historic structures listed in Table 1.05-1. Historic architectural features that should receive particular attention during visual inspections should be highlighted.
2. Construction Reporting
 - a. During construction the Contractor shall submit monthly status reports to the NJDEP summarizing the daily log data with special emphasis given to any abnormalities. Bi-annual reports shall be provided for the SHPO. Reports shall contain information on the status of historic resources/structures and information pertinent to the excavation and construction activities required to implement the SSM project. Supplement reports with plans, cross-sections, photographs, and summary instrumentation monitoring data relevant to the period of the report in question.
 - b. In the event of critical level readings, reporting is required to: i) document the condition of the historic property(s) especially if damage is present; ii) document the conditions which caused said readings; and iii) provide a detailed plan to mitigate any potential future critical level readings. The NJDEP and SHPO review this report before construction activities can resume.
3. Final Post-construction Report
 - a. Produce a final post construction report summarizing the information of the interim reports, noting any significant findings to include:
 - (1) a summation of all instrumentation monitoring results as well as key plans and cross sections showing key stages and/or the advancement of the works throughout the duration of the project in the final report;
 - (2) a general discussion that summarizes the work completed, progress, problems encountered and all incidences and occurrences, which were recorded over the duration of the contract; and

- (3) photo-documentation of changes to the condition of historic structures in the report.

END OF SECTION 023214

NO TEXT ON THIS PAGE

SECTION 023219 - SUBSURFACE UTILITY LOCATING (POTHOLING)

PART 1 - GENERAL

1.01 DESCRIPTION

- A. This Section includes materials and procedures for performing pothole operations to locate existing underground utilities.

1.02 PAYMENT

- A. No separate payment shall be made for performing any Work required under this Section. All costs for Work required by this Section shall be included in the applicable lump sum(s), unit price(s), or allowance(s) as set forth in Section 012901.

1.03 REFERENCES

- A. American Society of Civil Engineers (ASCE):
 - 1. Standard 38: Standard Guidelines for the Collection and Depiction of Existing Subsurface Utility Data.

1.04 RELATED SECTIONS

- A. General Conditions Article 4.7 – Shop Drawings and Other Submittals.
- B. Section 011414 - Control of Work.
- C. Section 012901 – Measurement and Payment.
- D. Section 017700 - Contract Closeout.
- E. Section 021600 - Excess Clean Fill, Contaminated Soil, and Groundwater Management and Disposal.
- F. Section 033000 - Cast-In-Place Concrete.
- G. Section 312300 - Excavation and Fill.
- H. Section 321200 – Flexible Paving.
- I. Section 321600 – Concrete Curbs, Gutters, and Sidewalks.

1.05 SUBMITTALS

- A. Submit the following in accordance with General Conditions Article 4.7.

- B. Submit a traffic control/protection plan at least 15 calendar days prior to the commencement of field activities.
- C. Submit proposed method of potholing, including description of equipment to be used, at least 15 calendar days prior to the commencement of field activities.
- D. Submit field logs certified by a land surveyor registered in the State of New Jersey to the Construction Manager within two (2) working days after the completion of each pothole. Include date of potholing and any additional discovered information or pertinent data. Include for each pothole excavation field log:
 - 1. Pothole number.
 - 2. Date of pothole.
 - 3. Utility type and size.
 - 4. Miscellaneous Contractor’s notes.
 - 5. Elevation at top and bottom of utility.
 - 6. Elevation of existing grade over utility at pothole.
 - 7. Description of location including Northing and Easting coordinates in project coordinate system.
 - 8. Outside diameter of utility or width of duct banks.
 - 9. Utility material and condition.
- E. Submit proposed method of backfill, including mix design for each proposed alternate backfill material, such as controlled low strength material, at least 15 calendar days prior to the commencement of field activities.

1.06 PROCEDURES

- A. Obtain Road Opening Permit from the Municipality or County in which the pothole is to be excavated – comply with all provisions of the approved permit.
- B. Subsurface utility-locating (potholing) services shall conform to ASCE 38, Quality Level A. For the purpose of this scope, “locate” means to obtain the horizontal and vertical position of the utility by excavating a test hole or narrow trench where requested by the Construction Manager. Perform test holes using vacuum excavation or comparable nondestructive equipment in a manner that will not damage the utility.

- C. Before excavating, locate existing subsurface structures and utilities that may be affected by or interfere with proposed construction. Obtain utility locations as specified in Section 011414. If directed by the Construction Manager, pothole to locate the utility.
- D. Obtain Construction Manager’s approval of pothole locations prior to commencement of potholing.

1.07 TIME OF COMPLETION/SCHEDULE

- A. The Contractor is to schedule and perform all the test pits at the initiation of the Contract. The Architect/Engineer will provide a schedule of test pits to the Contractor at the pre-construction conference. The Contractor shall perform the test pits on that schedule in a single mobilization. The test pit locations may be in paved areas, railroad property or on private property. The Contractor shall apply for and obtain all road opening permits and access approvals, with the assistance of the DEP and Architect/Engineer, needed to perform the test pits. Once the permits or access agreements are obtained, the Contractor shall perform the test pit and submit the data to the Architect/Engineer for their evaluation.

PART 2 - PRODUCTS

2.01 MATERIALS

- A. Dense Graded Aggregate (DGA) in conformance with Section 312300.
- B. Controlled Low Strength Material (CLSM) shall be in conformance with Section 033400.
- C. Asphalt Concrete Pavement Repair at potholes
 - 1. Asphalt concrete paving shall conform to Section 321200.
 - 2. Aggregate shall be NJDOT Specifications, Section 901.11, Designation I-5Paving thickness shall match existing plus 1 inch.

PART 3 - EXECUTION

3.01 POTHOLING OPERATIONS

- A. Underground Service Alert Requirements: Comply with all requirements of the One-Call Damage Prevention System. Contact New Jersey One Call at <https://www.nj1-call.org/> or 1-800-272-1000 (or 811) no less than three (3) and no more than ten (10) days prior to the start of subsurface work. Verify with each utility owner if a utility representative is required to be present during excavation and, if required, coordinate with representative. Take all precautions required by the utility owner.

- B. Apply for and obtain all road opening permits and access permissions prior to the Work.
- C. Furnish, install, maintain, and remove necessary traffic signs, barricades, lights, signals, cones, pavement markings, and other traffic control devices. Perform traffic control in accordance with Contract Sections, MUTCD and OSHA Regulations for Construction Projects.
- D. Conduct potholing operations in a manner that minimizes the damage potential to existing underground utilities in order to ensure that the existing facilities will remain in operation without interruption. Contractor shall be responsible for, and repair to pre-existing condition (at Contractor's expense) existing underground utilities damaged by potholing operations.
- E. Backfill and repair test hole excavations immediately after obtaining the measurement data. Backfill and repair trench excavations requiring use of temporary steel plate bridging within four (4) working days.
- F. Location and Depiction of Existing Utilities: If discrepancies in the utility location are suspected, promptly notify the Construction Manager prior to commencement of any excavation.

3.02 EXCAVATION

- A. Neatly sawcut and remove existing pavement. Excavate test holes in such a manner as to prevent damage to wrappings, coatings, or other protective coverings, use vacuum excavation or hand digging.
- B. Hand dig within two (2) feet of marked facilities.
- C. Protect utilities and underground structures from damage during potholing. If the Contractor damages a utility, immediately notify the affected utility owner and the Construction Manager. Call 911 if a gas or petroleum facility is damaged. Repair utilities damaged as a result of Contractor's or its subcontractor's operations as soon as allowed by the affected utility and in accordance with the utility owner's requirements. If the utility owner repairs damage that results from Contractor operations, reimburse the utility for the cost of making the repair. All repairs required due to the damage incurred by the Contractor's or its subcontractor's operations shall be done at no cost to the DEP.
- D. Backhoe excavation is not permitted. Use the following methods for excavation:
 - 1. Hand Digging: Hand digging is the method of excavating a pothole by manual means with hand-held, nonmechanical equipment such as a shovel.
 - 2. Vacuum Excavation: Vacuum excavation uses air or water pressure to break up the soil and a vacuum device to collect the spoil. Determine which method to use based on specific site and environmental characteristics. Soil type such as heavy clay may

require water vacuum excavation. Use air vacuum excavators if mud from water vacuum excavators cannot be disposed of properly. Use air vacuum excavators if damage to utilities, such as cutting through cables, is possible with the use of water vacuum excavators.

- a. Air Vacuum Excavation: Use a high velocity air stream to penetrate, expand, and break up the soil. Remove the loosened particles of soil and rock from the excavation with a vacuum.
 - b. Water Vacuum Excavation: Use high-pressure water to reduce and loosen the soil. Remove the wet soil and mud slurry to a spoil tank using a vacuum.
- E. Size of Test Hole Excavation: Maximum test hole dimension shall be 12 inches at surface, unless indicated otherwise, or approved by Construction Manager due to subsurface conditions or size of utility facility.
- F. Size of Exploratory Trench Excavation: Trench width and length shall be as approved by the Construction Manager. Width and length may be affected by subsurface conditions. Trench depth shall be as required to accurately locate subsurface utilities.

3.03 TEMPORARY STEEL PLATE BRIDGING

- A. Provide temporary steel plate bridging with a nonskid surface and shoring to preserve unobstructed traffic flow according to the Contract Documents.
- B. Use a “Rough Road” sign (W8-8) with black lettering on an orange background in advanced of steel plate bridging. This is to be used along with any other required construction signing.

3.04 POTHOLE REPAIR

- A. In paved roadways, sidewalks or railroad property.
 1. After excavating a test hole or trench, provide and install temporary steel plate bridging to facilitate data gathering.
 2. After obtaining the required data, remove steel plate bridging, and backfill excavation as required by the road opening permit or property Owner’s requirements. Bring to grade with surface. Match existing pavement thickness plus 1 inch. Do not mix backfill materials. Do not use CLSM to replace pavement, base course or drainage layers that form the pavement structure. Contractor if to provide and maintain a smooth driving or walking surface.
 3. If CLSM is allowed, place CLSM in accord with and to the limitations for specified in Section 033400. After placement protect CLSM as specified in Section 033400.

4. The finished surface of the repair shall be of like material and constructed to the same finished grade as the adjacent pavement. The finished surface shall be such that it does not allow water to pond. There shall be no discernable difference in surface level at the joint between the existing pavement and the completed repair.

B. Non-paved areas.

1. After excavating a test hole or trench, provide and install temporary steel plate bridging to facilitate data gathering.
2. After obtaining the required data, remove steel plate bridging, and backfill excavation with excavated material excavated from the same pothole in accordance with Sections 021600 and 312300. Bring to grade with surface. Match existing surface plus 1 inch. Do not mix backfill materials.

3.05 DISPOSAL OF CUTTINGS

- A. Dispose of or reuse excess excavation in accordance with Section 021600.

3.06 CONTRACT CLOSEOUT

- A. Provide in accordance with Section 017700.

END OF SECTION 023219

SECTION 025100 - DECONTAMINATION

PART 1 – GENERAL

1.01 DESCRIPTION

- A. This Section covers the decontamination of personnel and equipment as they move from the Exclusion or Work Zones to Support Zones and off-site. Decontamination is required throughout Work activities.

1.02 PAYMENT

- A. No separate payment shall be made for performing any Work required under this Section. All costs for Work required by this Section shall be included in the applicable lump sum(s), unit price(s), or allowance(s) as set forth in Section 012901.

1.03 RELATED SECTIONS

- A. General Conditions Article 4.7 – Shop Drawings and Other Submittals.
- B. Section 012901 – Measurement and Payment.
- C. Section 014150 - Health and Safety Requirements.

1.04 LAWS AND REGULATIONS

- A. All work under this Contract shall be accomplished in accordance with regulations of local, county, State, and Federal agencies and utility authority standards as they apply.

1.05 SAFETY

- A. Methods of operation utilized in Work related to these specifications shall be such as to provide maximum protection against injury or death to workmen or the public. Requirements of the United States and New Jersey Occupational Safety and Health Acts as to safety regulations and procedures shall be adhered to for all Work covered under these Contract Sections.

1.06 SUBMITTALS

- A. Submit the following items in accordance with General Conditions Article 4.7
- B. Prior to mobilization, Contractor shall submit personnel decontamination procedures as part of the Contractor's Health and Safety Plan (HASP) specified in Section 014150. Contractor shall provide the following information:

1. Number and location of decontamination and wheel wash stations.
2. Decontamination methods and equipment that shall be used in accordance with applicable New Jersey Department of Environmental Protection (NJDEP) requirements.
3. Procedures to prevent cross-contamination of clean areas during remedial activities.
4. Methods and procedures to minimize worker contact with contaminants during removal of personal protective equipment (PPE).
5. Procedures for inspection and decontamination of vehicles leaving the site.
6. Procedures for disposal of personal PPE.
7. Procedures for the collection of all decontamination water and residuals.
8. Procedures for minimizing generation of wastewater.

1.07 DECONTAMINATION FACILITIES

- A. Contractor shall construct and maintain decontamination facilities for equipment and trucks as described in the Contract Documents.
- B. Contractor shall construct and maintain decontamination facilities for personnel.
- C. Construction of new decontamination facilities is not required if existing decontamination facilities from previous phases of Work are available and optimally located.

PART 2 – PRODUCTS

2.01 DECONTAMINATION EQUIPMENT

- A. Contractor shall provide all equipment necessary to complete decontamination activities such as, but not limited to:
 1. Power washer (heated if needed), shower, brushes, and receptacle for PPE, etc.

PART 3 – EXECUTION

3.01 VEHICLE/EQUIPMENT DECONTAMINATION

- A. Work zones shall be established as specified in the Contractor’s HASP and Technical Execution Plan.
- B. Contractor shall inspect and decontaminate all vehicles and equipment that have entered the Exclusion Zone. All decontamination shall take place in Decontamination Zones.
- C. Decontamination of vehicles and equipment shall include removal of soil and residues from the chassis (which includes undercarriage, suspension, wheel wells, tires, and wheels) and other parts of the vehicle known to have been contaminated or visually appearing to be contaminated.
- D. Contractor shall take care while decontaminating vehicles to avoid contaminating personnel, other parts of the vehicle or equipment, or the surroundings. Personnel involved in vehicle and equipment decontamination shall be dressed in the appropriate level of PPE as determined by the HASP. All personnel shall follow applicable safety procedures described in Section 014150.
- E. Contractor shall decontaminate haul trucks after loading and before the haul trucks exit exclusion zones if inspection indicates the presence of contaminants. Contractor shall ensure that haul trucks exit through the Decontamination Zone and receive proper decontamination and inspection.

3.02 PERSONNEL DECONTAMINATION

- A. Contractor shall ensure that personnel who have entered the Exclusion Zone perform decontamination as required in the HASP as specified in Section 014150 prior to exiting the Decontamination Zone.

3.03 DECONTAMINATION METHODS

- A. Physical decontamination techniques used during truck and equipment decontamination include but are not limited to brushing and spraying with a heated water pressure washer until all visible contamination and debris is removed.
- B. Brushing shall consist of removal of loose materials with the use of a broom and/or brushes.
- C. A heated pressure washer shall be used to provide application of water of sufficient temperature, pressure, residence time, and agitation to remove soil and contaminated residuals from surfaces.

- D. Surfactants and detergents must be approved by the Construction Manager prior to use in decontamination operations. Materials which may be detrimental to water treatment, handling, or disposal shall not be allowed.
- E. All equipment decontamination procedures shall be performed in a decontamination facility or area.
- F. Overspray barriers shall be provided, if necessary or as directed by the Construction Manager on each side of the decontamination area to prevent contamination of adjacent areas.
- G. Contractor shall manage decontamination residuals, including water, soil, residues, used PPE, and other materials removed during decontamination as specified in Paragraph 3.04 Management of Decontamination Residuals.

3.04 MANAGEMENT OF DECONTAMINATION RESIDUALS

- A. Decontamination liquids shall be collected by the Contractor during personnel decontamination, truck and equipment decontamination.
- B. Decontamination liquids shall be disposed offsite at Construction Manager-approved disposal facility.
- C. The Contractor shall dewater and collect decontamination solids. Dewatered decontamination solids shall be allowed to air dry in a stockpile pad for off-site disposal at a NJDEP-approved disposal facility acceptable to the Construction Manager and the Construction Manager's Licensed Site Remediation Professional (LSRP). The Contractor will be responsible for loading this material into trucks.
- D. The Contractor shall manage contaminated PPE when working in impacted areas as Impacted Material to be sent to a NJDEP-approved disposal facility acceptable to the Construction Manager and the Construction Manager's LSRP.
- E. When the decontamination pad is no longer required, the Contractor shall remove the contents, including but not limited to gravel, sumps, and liner, and dispose of the material at a NJDEP-approved off-site facility approved by the Construction Manager and the Construction Manager's LSRP.

END OF SECTION 025100

SECTION 031000 - CONCRETE FORMWORK

PART 1 - GENERAL

1.01 DESCRIPTION

- A. Provide design and furnish materials for fabricating, erecting and removing formwork, falsework, and shoring for cast-in-place concrete as indicated and in compliance with Contract Documents.
- B. Use formwork to cast all cast-in-place concrete structures.
- C. Provide and remove all formwork for electrical work as shown on the Contract Drawings or specified under electrical work.

1.02 PAYMENT

- A. No separate payment shall be made for performing any Work required under this Section. All costs for Work required by this Section shall be included in the applicable lump sum(s), unit price(s), or allowance(s) as set forth in Section 012901.

1.03 REFERENCES

- A. American Concrete Institute (ACI):
 - 1. 117/117R: Standard Tolerances for Concrete Construction and Materials.
 - 2. 309.2R: Identification and Control of Visible Effects of Consolidation on Formed Concrete Surfaces.
 - 3. 318/318R: Building Code Requirements for Structural Concrete and Commentary.
 - 4. 347: Guide to Formwork for Concrete.
- B. Engineered Wood Association (APA)
- C. National Institute of Product Standards and Technology:
 - 1. Voluntary Product Standard PS 1 Structural Plywood.

1.04 RELATED SECTIONS

- A. General Conditions Article 4.7 – Shop Drawings and Other Submittals
- B. Section 012901 – Measurement and Payment

- C. Section 014300 - Quality Requirements
- D. Section 016100 - Control of Materials
- E. Section 017700 - Contract Closeout
- F. Section 033000 - Cast-in-Place Concrete

1.05 DESIGN REQUIREMENTS

- A. Design formwork in conformance with methodology of ACI 347R for anticipated loads, lateral pressures, depth of concrete placement, and rate of concrete placement. Design shall consider any special requirements due to the use of self-consolidating, plasticized and/or retarded set concrete. All forms and shoring shall be designed at the Contractor's expense.

1.06 QUALIFICATIONS

- A. Formwork Designer: Formwork, falsework, and shoring design shall be by an engineer licensed in the State of New Jersey.

1.07 SUBMITTALS

- A. Submit the following in accordance with General Conditions Article 4.7.
- B. Submit product data for form ties, spreaders, chamfer strips, form coatings, bond breakers, plywood, concrete form hard board, form accessories, prefabricated forms, and form-lining materials.
- C. The following information is to be signed and sealed by a professional engineer licensed in the State of New Jersey. The Architect/Engineer will review and evaluate the submittal.
 - 1. Formwork and falsework drawings and design computations shall be sealed by the Contractor's Engineer and shall be submitted at least 30 days either before fabrication on site or before delivery of prefabricated forms. The shop drawings and data submitted shall include the type, size, quantity, and strength of all materials of which the forms are made, the plan for jointing of facing panels, details affecting the appearance, and the assumed design values and loading conditions.
 - 2. If reshoring is permitted, the method, including location, order, and time of erection and removal shall also be submitted for review.
 - 3. If forms are to be removed in less than 24 hours on formwork not supporting the weight of concrete, the evaluation and results of the control cylinder tests shall be submitted and approved before the forms are removed.

4. If a metal formwork system is to be used, details of the forming system and provisions for insulation shall be submitted for review.
5. Layout of panel joints, layout and profile of panels for architectural finish and tie hole pattern for architectural formwork shall be submitted for review.
6. Form Ties-Tapered Through-Bolts: Proposed method of sealing form tie holes shall be submitted for review.

1.08 QUALITY ASSURANCE

- A. Comply with requirements in Section 014300 and as specified.
- B. Design of Formwork:
 1. The Contractor shall assume responsibility for the design, engineering, and construction of formwork. Forms shall be designed to produce concrete members identical in shape, lines, and dimensions to members shown on the Contract Documents.
 2. When high range water reducer (superplasticizer) is used in concrete mix or when self-consolidated concrete is specified, forms shall be designed for full hydrostatic pressure per ACI 347.
 3. The formwork shall be designed for anticipated live and dead loads. The loads and lateral pressures in accordance with ACI 347 and wind loads as specified by the local building code.
 4. Construction and contraction joints, openings, offsets, keyways, recesses, moldings, chamfers, blocking, screeds, bulkheads, waterstops, anchorages, inserts, and other features shall be provided.
 5. Formwork shall be designed to be readily removable without impact, shock, or damage to 'green' concrete surfaces and adjacent materials.
 6. The maximum panel deflection shall be $1/360$ of the span between structural members.
- C. Unless otherwise specified herein, formwork shall be constructed so that the concrete surfaces will conform to the tolerance limits as given in ACI 117.
- D. Forms, embedded items, ties, and other accessories shall be inspected in sufficient time prior to each concrete placement by the Contractor in order to certify to the Construction Manager that they are ready to receive concrete. Inspection of forms for concrete shall include a detailed evaluation of leakage control measures, type and application of release agent, and form cleanliness to avoid dirt transfer to the concrete.

- E. Materials, fabrications, and workmanship found defective shall be promptly removed and replaced and new acceptable work shall be provided in accordance with Contract requirements at no additional cost to the DEP.
- F. Inspection. Forms and embedded items shall be inspected in sufficient time prior to each concrete placement by the Contractor in order to certify to the Construction Manager that they are ready to receive concrete. The results of each inspection shall be reported in writing.
- G. Reporting. The results of each inspection shall be reported in writing and shall include, but not be limited to, the following:
 - 1. Removal of extraneous material from forms.
 - 2. Check of joints for mortar tightness.
 - 3. Type of form material required for the concrete finish.
 - 4. Falsework and/or bracing.
 - 5. Alignment, tolerances, and dimensions.
 - 6. Chamfering.
 - 7. Form coating.

The original and two copies of these reports, as well as corrective action taken, shall be furnished to the Construction Manager daily.

1.09 DELIVERY, STORAGE AND HANDLING

- A. Comply with the requirements in Section 016100.
- B. Materials shall be delivered to the site in an undamaged condition and at such intervals as to avoid delay in the work.
- C. Material shall be stored and protected in a clean, properly drained location. Material shall be kept off the ground under a weather-tight covering permitting good air circulation. Formwork materials shall be stored on dry wood sleepers, pallets, platforms, or other appropriate supports which have slope for positive drainage. Materials shall be protected from distortion, excessive stresses, corrosion, and other damage. Materials shall not be stored on the structure in a manner that might cause distortion or damage to the supporting structure.

PART 2 - PRODUCTS

2.01 LUMBER

- A. Lumber used in form construction shall be Southern Yellow Pine, No. 2, S4S, Standard Grade Rules Southern Pine Inspection Bureau. Boards shall be 6 inches or more in width.

2.02 PLYWOOD

- A. Only grade-marked plywood conforming to APA shall be provided.
- B. Plywood used in form construction shall be Grade B-B, Class 1 plyform, mill-oiled, and sanded on both sides in conformance with U.S. Product Standard PS 1 Structural Plywood.
- C. Thickness shall be sized to maintain alignment and surface smoothness, but not less than 5/8-inch thick.

2.03 STEEL FORMS

- A. Commercial grade sheets not less than 16 gage shall be provided.
- B. Stock material that is free from warps, bends, kinks, cracks, and rust or other matter that could stain the concrete shall be provided.

2.04 FORM MATERIAL LOCATIONS

- A. Wall Forms:
 - 1. Materials: Plywood, hard plastic finished plywood, overlaid waterproof particleboard, or steel in new and undamaged condition, of sufficient strength and surface smoothness to produce specified finish.
- B. All Other Forms: Materials as specified for wall forms.
- C. Rustication Grooves and Chamfer Strips: Nonabsorbent material, compatible with form surface, fully sealed on all sides, prohibiting loss of paste or water between the two surfaces.

2.05 FORM TIES

- A. Locate form ties on exposed surfaces in a uniform pattern. Place form ties so they remain embedded in the concrete except for a removable portion at each end. Form ties shall have conical or spherical type inserts with a maximum diameter of 1 inch. Construct form ties so that no metal is within 1-1/2 inch of the concrete surface when the forms, inserts, and tie ends are removed. Form ties shall be constructed so that the

ends or end fasteners can be removed without spalling the concrete. Removable tie rods shall not be allowed. Ties shall withstand all pressures and maintain forms within acceptable deflection limits. Safety factors for form ties, anchors and hangers shall comply with the standards of ACI 347.

- B. Tapered form ties shall not be allowed.
- C. Wire ties are not permitted.
- D. Elastic Vinyl Plug:
 - 1. Design and size of plug shall allow insertion with tool to enable plug to elongate and return to original length and diameter upon removal, forming watertight seal.

2.06 BOND BREAKER

- A. Bond breaker shall be a V.O.C.-compliant non-staining type that will provide a positive bond prevention. The coating shall not impair subsequent treatment of concrete surfaces depending upon bond or adhesion nor impede the wetting of surfaces to be cured with water or curing compounds.

2.07 FORM LINERS

- A. Forms and form liners shall be fabricated with facing materials that will produce a finish meeting the specified construction tolerance requirements and the following surface classifications as defined in ACI 347.
 - 1. Class "A" Finish - This class of finish shall apply to all exterior formed surfaces not covered by backfill. The form facing material shall be composed of new, well matched tongue and groove lumber or new plywood panels conforming to NIST Product Standard PS-51, Grade B Concrete Form, Class I; High Density Overlay, all Exterior Type. The Grade B Side shall be stamped as such and shall face the concrete.
 - 2. Class "D" Finish - This class of finish shall apply to all unexposed surfaces. The form facing may be of wood or steel.

2.08 RUSTICATIONS AND ARCHITECTURAL TREATMENT

- A. Rustications shall be provided as shown on Contract Documents. Any rustications shall not reduce the maximum thickness of a member as shown on the structural Contract Drawings.
- B. Cast-in-place concrete elements which are to have a finish other than the surface produced from standard formwork shall be accomplished by providing High Density

Poly-Ethylene material in size and shapes indicated on architectural detailing, for face pattern of poured concrete walls as per Architectural Elevations and approved shop drawings. The minimum thickness of walls shall not be reduced from what is shown on the structural Contract Drawings due to architectural detailing applied to the face of the walls.

2.09 FORM CAULKING

- A. Form caulking shall be a one-component, gun-grade silicone sealant that is capable of producing flush, watertight, and non-absorbent surfaces and joints. Sealant shall be compatible with the type of forming material and concrete ingredients used.

2.10 CHAMFER STRIPS

- A. Provide 3/4 inch by 3/4-inch chamfer strips milled from clear, straight-grain pine, surfaced each side, or having extruded vinyl type with or without nailing flange unless otherwise shown on the Contract Documents.

2.11 INSERTS

- A. Provide galvanized cast steel or galvanized welded steel inserts, complete with anchors, to concrete and fittings such as bolts, wedges, and straps.

2.12 FORM RELEASE AGENT

- A. Form release agent shall not bond with, stain, or adversely affect concrete surfaces and shall not impair subsequent treatments of concrete surfaces when applied to forms. A ready-to-use, water-based material formulated to reduce or eliminate surface imperfections and containing no mineral oil or organic solvents shall be used.

PART 3 - EXECUTION

3.01 FORM TOLERANCES

- A. Comply with the requirements of ACI 117 for tolerances for formed surfaces, except as specified in Table 031000-1.

Table 031000-1	
Vertical alignment (plumbness)	1/4-inch in any 10 feet
Variation in the lines and surfaces of foundation mats, base slabs and walls	1/4-inch in any 10 feet
Variation from the level or from the grades indicated on the drawings	1/4-inch in any 10 feet

Table 031000-1	
Horizontal dimension of formed members	Plus 2 inch Minus ½ inch
Variation in the sizes and locations of sleeves, floor openings, and wall openings	Minus 1/4-inch Plus 1/2-inch
Offset between adjacent panels of formwork facing material	1/2-inch (ACI 117 Class C finish)

- B. Tolerances are not cumulative.
- C. Where equipment is to be installed, comply with manufacturer's tolerances if more restrictive than above.
- D. Failure of the forms to produce the specified concrete surface and surface tolerance shall be grounds for rejection of the concrete work. Rejected work shall be repaired or replaced at no additional cost to the DEP.
- E. Condition of the forms shall be maintained in “as new” condition. When using lumber or plywood formwork special attention shall be given to proper edge protection. Where formwork results in the rejection of the Work, the formwork shall be discarded and replaced. Unless otherwise permitted by the Construction Manager, maximum formwork reuse shall be limited to:
 - 1. Lumber – five (5) reuses.
 - 2. Plywood – B-B Plyform – five (5) reuses.
 - 3. Plywood – High Density Overlay (HDO) – twenty-five (25) reuses.
 - 4. Steel Panels – thirty-five (35) reuses.
- F. Formliners and Architectural Treatment Rustications shall be as detailed on the drawings and shall be limited to 6 to 10 reuses, pursuant to Construction Manager satisfactory surface condition inspection prior to reuse.

3.02 PREPARATION

- A. Clean form surfaces of any hardened concrete or foreign material prior to installation. Tape, gasket, plug, and/or caulk joints, gaps, and apertures in forms so that the joint will remain watertight and withstand placing pressures without bulging outward or creating surface irregularities.
- B. Coat form surfaces in contact with concrete with a form release agent prior to form installation. The use of waste oil or used oil as a form-release agent or form oil is prohibited.

- C. Keep form coatings off steel reinforcement, items to be embedded, and previously placed concrete.
- D. The coating shall be used as recommended in the manufacturer's instructions.
- E. Steel Forms: Apply form release agent to steel forms as soon as they are cleaned to prevent discoloration of concrete from rust.
- F. Form liners to be installed for architectural concrete finish shall be in accordance to the manufacturer recommendations.
- G. Surplus coating on form surfaces and coating on reinforcing steel and construction joints shall be removed before placing concrete.
- H. Coatings that discolor concrete or are incompatible with their concrete materials are prohibited.

3.03 ERECTION AND INSTALLATION

- A. Forms shall be constructed in accordance with ACI 347 to required dimensions, plumb, straight and mortar tight, and all joints and seams shall be made mortar-tight. Forms shall be substantial, properly braced, and tied together to maintain position and shape and to resist all pressures to which they may be subject. Unless otherwise indicated on the Contract Documents, formwork shall be constructed so that the concrete surfaces will conform to the tolerance limits in ACI 117 and herein specified.
- B. Provide means for holding adjacent edges and ends of form panels tight and in accurate alignment to prevent the formation of ridges, fins, offsets, or similar surface defects in the finished concrete. Forms shall be tight and shall prevent the loss of mortar and fines during placing and vibration of concrete.
- C. All exposed joints, edges, and external corners shall be chamfered by molding placed in the forms unless the Contract Drawings specifically state that chamfering is to be omitted or as otherwise specified. Chamfered joints shall not be permitted where earth or rockfill is placed in contact with concrete surfaces. Chamfered joints shall be terminated 12 inches outside the limit of the earth or rockfill so that the end of the chamfers will be clearly visible.
- D. Provide means for removing forms without injury to the surface of finished concrete.
- E. Do not embed any form-tying device or part thereof other than metal in the concrete.
- F. Use only form or form-tying methods that do not cause spalling of the concrete upon form stripping or tie removal.

- G. Set anchor bolts and other embedded items accurately before placing concrete and hold securely in position until the concrete is placed and set. Check special castings, channels, or other metal parts that are to be embedded in the concrete prior to and again after placing concrete. Check nailing blocks, plugs, and strips necessary for the attachment of trim, finish, and similar work prior to placing concrete.
- H. The ground shall not be used for forming.
- I. Failure of any supporting surface either due to surface texture, deflection or form collapse shall be the responsibility of the Contractor as will the replacement or correction of unsatisfactory surfaces. Forms shall not be re-used if there is any evidence of defects which would impair the quality of the resulting concrete surface. All surfaces of used forms shall be cleaned of mortar and any other foreign material before reuse.

3.04 PROTECTION

- A. During installation, the forms shall not be used as a storage platform or as a working platform until the forms have been permanently fastened in position.

3.05 REMOVAL OF FORMS

- A. Forms shall not be removed without approval. The minimal time required for concrete to reach a strength adequate for removal of formwork without risking the safety of workers or the quality of the concrete depends on a number of factors including, but not limited to, ambient temperature, concrete lift heights, type and amount of concrete admixture, and type and amount of cementitious material in the concrete. It is the responsibility of the Contractor to consider all applicable factors and leave the forms in place until it is safe to remove them. In any case, forms shall not be removed unless the minimum compressive strength requirements have been achieved, except as otherwise directed or specifically authorized. When conditions are such as to justify the requirement, forms will be required to remain in place for a longer period. All removal shall be accomplished in a manner which will prevent damage to the concrete and ensure the complete safety of the structure. Where forms support more than one element, the forms shall not be removed until the form removal criteria are met by all supported elements. Form removal shall be scheduled so that all necessary repairs can be performed as specified in Section 033000, paragraph 3.11.C.5 “Formed Surface Repair.” Evidence that concrete has gained sufficient strength to permit removal of forms shall be determined by tests on control cylinders. All control cylinders shall be stored in the structure, or as near the structure as possible, so they receive the same curing conditions and protection methods as given those portions of the structure they represent. Control cylinders shall be removed from the molds at an age of no more than 24 hours. All control cylinders shall be prepared and tested in accordance with ASTM C 31/C 31M and ASTM C 39/C 39M at the expense of the Contractor by an independent laboratory that complies with ASTM C 1077 and shall be tested within four (4) hours after removal from the site.

1. Formwork Not Supporting Weight of Concrete
 - a. Formwork for walls, columns, sides of beams, gravity structures, and other vertical type formwork not supporting the weight of concrete shall not be removed in less than 24 hours after concrete placement is completed. Form removal before 24 hours will be allowed for simple sidewalks and driveways provided the ambient temperature during this period has not fallen below 50 degrees F at any time since placement. Control cylinders shall be prepared for each set of forms to be removed before 24 hours. The stability of the concrete shall be evaluated by a structural engineer prior to removal of the forms. The Contractor shall submit design data for the formwork for review by the Construction Manager.

2. Formwork Supporting Weight of Concrete
 - a. Formwork supporting weight of concrete and shoring shall not be removed until structural members have acquired sufficient strength to safely support their own weight and any construction or other superimposed loads to which the supported concrete may be subjected. As a minimum, forms shall be left in place until control concrete test cylinders indicate evidence the concrete has attained at least 75 percent of the compressive strength required for the structure in accordance with the quality and location requirements of Section 033000. The Contractor shall submit design data for the formwork for approval of the Construction Manager.

3.06 ALUMINUM SURFACES IN CONTACT WITH CONCRETE

- A. No aluminum shall be permitted to come into contact with concrete.

3.07 CONTRACT CLOSEOUT

- A. Provide in accordance with Section 017700.

END OF SECTION 031000

NO TEXT ON THIS PAGE

SECTION 031500 - CONCRETE JOINTS AND ACCESSORIES

PART 1 - GENERAL

1.01 DESCRIPTION

- A. This Section describes materials, testing, and installation of concrete joints and accessories as specified and as shown on Contract Drawings.

1.02 PAYMENT

- A. No separate payment shall be made for performing any Work required under this Section. All costs for Work required by this Section shall be included in the applicable lump sum(s), unit price(s), or allowance(s) as set forth in Section 012901.

1.03 REFERENCES

- A. ASTM International (ASTM):
 1. A276: Standard Specification for Stainless Steel Bars and Shapes.
 2. C920: Specification for Elastomeric Joint Sealants.
 3. C1193: Guide for Use of Joint Sealants.
 4. D412: Standard Test Methods or Vulcanized Rubber and Thermoplastic Elastomers – Tension.
 5. D570: Standard Test Method for Water Absorption of Plastics.
 6. D624: Standard Test method for Tear Strength of Conventional Vulcanized Rubber and Thermoplastic Elastomers.
 7. D638: Standard Test Method for Tensile Properties of Plastics.
 8. D746: Standard Test Method for Brittleness Temperature of Plastics and Elastomers by Impact.
 9. D747: Standard Test Method for Apparent Bending Modulus of Plastics by Means of a Cantilever Beam.
 10. D792: Standard Test Methods for Density and Specific Gravity of Plastics by Displacement.
 11. D994: Standard Specification for Preformed Expansion Joint Filler for Concrete (Bituminous Type).

12. D1171: Standard Test Method for Rubber Deterioration – Surface Ozone Cracking Outdoors or Chamber (Triangular Specimens).
13. D1259: Standard Test Methods for Nonvolatile Content of Resin Solutions.
14. D1752: Specification for Preformed Sponge Rubber and Cork Expansion Joint Fillers for Concrete Paving and Structural Construction.
15. D2240: Standard Test Method for Rubber Property – Durometer Hardness.

B. Environmental Protection Agency (EPA):

1. 40 CFR 59: National Volatile Organic Compound Emission Standards for Consumer and Commercial Products.

C. United States Army Corps of Engineers (USACE):

1. CRD-C 572: Specifications for Polyvinylchloride Waterstop.

D. Federal Specifications:

1. TT-S-00230C: Sealing Compound: Elastomeric Type, Single Component.
2. Federal Test Method Standard No. 601.

1.04 RELATED SECTIONS

- A. General Conditions Article 4.7 – Shop Drawings and Other Submittals.
- B. Section 012901 – Measurement and Payment.
- C. Section 014300 - Quality Requirements.
- D. Section 016100 - Control of Materials.
- E. Section 017700 - Contract Closeout.

1.05 SUBMITTALS

- A. Submit following shop drawings in accordance with General Conditions Article 4.7.
 1. Shop drawings and fabrication drawings provided by the manufacturer or prepared by the Contractor.
 2. Manufacturer's printed data and application instructions for specified materials and locations where materials are to be used.

3. One (1) material sample of each type of waterstop.
4. Layouts for joints.
5. Certifications that materials used within the joint system are compatible with each other and to verify compliance with applicable specifications.

1.06 QUALITY ASSURANCE

- A. Comply with requirements in Section 014300 and as specified.
- B. Do not add, relocate, or omit joints without written permission from the Construction Manager.
- C. Reject material exceeding expiration date for use.
- D. Clean concrete surfaces to receive expansion joint compound in accordance with the printed instructions of the joint compound manufacturer.

1.07 DELIVERY, STORAGE AND HANDLING

- A. Comply with the requirements in Section 016100.
- B. Transport, handle, and deliver materials to the job site in the manufacturer's sealed bags, unopened containers or banded pallets.
- C. Store materials off the ground on a platform or skids and protect with covers from snow, rain, and ground splatter.
- D. Store expansion joint compounds in a dry location where they cannot freeze.
- E. Store plastic products under cover in a dry location, out of direct sunlight.

1.08 MANUFACTURER'S SERVICES

- A. Prior to joint preparation for joints receiving sealant materials, require joint manufacturer's technical representative to demonstrate, on site, joint preparation, priming, and sealant materials application for the Contractor's personnel performing joint work.

PART 2 - PRODUCTS

2.01 PVC WATERSTOP

- A. Waterstops shall be extruded from a PVC compound containing the plasticizers, resins, stabilizers, and other material necessary to meet the requirements of this Section. No

reclaimed or scrap material shall be used. The waterstops shall be lock-rib, center-bulb, retro-fit, or flat-strip type. Waterstop shall comply with Corps of Engineers Specification CRD-C-572.

- B. PVC waterstops for construction joints shall be flat ribbed type, 6 inches wide, unless otherwise noted on the Contract Drawings, with a minimum thickness of 3/8-inches.
- C. PVC waterstops for contraction joints shall be ribbed with a center bulb, 6 inches wide, with a minimum thickness of 3/8-inches. The center bulb shall have an O.D. not less than 7/8-inches.
- D. PVC waterstops for expansion joints shall be ribbed with a center bulb, 9 inches wide, with a minimum thickness of 3/8-inches. The center bulb shall have an O.D. not less than 1-3/8 inches.
- E. PVC waterstops for sealing existing concrete structures and new concrete placement shall be retro-fit type, 6 inches wide, and 3-3/16 inches height with a minimum thickness of 3/8-inches. Attach waterstop to existing concrete using 1/4-inch by 2-1/4-inch stainless steel sleeve expansion bolt with stainless steel batten bars.
- F. Provide waterstops resistant to chemical action with portland cement, alkalies, acids, and not affected by mildew or fungi. It shall show no effect when immersed for 10 days in a 10 percent solution of sulfuric or hydrochloric acid, saturated lime solution, or salt water. Waterstops shall be such that any cross section will be dense, homogeneous, and free from porosity and other imperfections. They shall be symmetrical in shape. When tested in accordance with Federal Test Method Standard No. 601, the material shall meet the requirements in Table 031500-1.

TABLE 031500-1	
Requirement	ASTM Spec.
Tensile strength, 2,000 psi	D638
Hardness, Shore durometer, 60-70	D2240
Elongation, ultimate, 350	D638
Water absorption, dry weight, maximum (48 hours) 0.32 percent	D570
Specific gravity, 1.3	D792
Stiffness in flexure, 600 psi	D747
Cold brittleness, -35 degrees F	D746
Tear resistance, 290 lbs/inch	D624

2.02 HYDROPHILIC RUBBER WATERSTOP

- A. Provide a bentonite free rubber waterstop. Waterstop shall expand by a minimum of 80 percent of dry volume in the presence of water to form a watertight joint seal without damaging the concrete in which it is cast. Provide minimum concrete cover as recommended by the waterstop manufacturer. Adhesive for securing the hydrophilic waterstop shall be as recommended by the manufacturer. Hydrophilic waterstop shall comply with the standards listed in Tables 031500-3 and 031500-4.

TABLE 031500-3		
Chloroprene Rubber		
Property	Test Method	Required Limits
Tensile Strength	ASTM D 412	1,300 psi, minimum
Ultimate Elongation	ASTM D 412	400%, minimum
Hardness (Shore A)	ASTM D 2240	50 +/-5
Tear resistance	ASTM D 624	100 lbs/inch, minimum

TABLE 031500-4		
Modified Chloroprene (Hydrophilic) Rubber		
Property	Test Method	Required Limits
Tensile Strength	ASTM D 412	350 psi, minimum
Ultimate Elongation	ASTM D 412	600%, minimum
Hardness (Shore A)	ASTM D 2240	52 +/-5
Expansion Ratio	Volumetric Change – Distilled Water @ 70 degrees F	3 to 1, minimum
Tear resistance	ASTM D 624	50 lbs/inch, minimum

2.03 ELASTOMERIC JOINT SEALANT

- A. Federal Specification TT-S-00230C Type 1, Class A, single component, cold applied, pourable, polyurethane.

2.04 JOINT SEALANT FOR CONCRETE STRUCTURES

- A. Joint sealant shall be a multipart, gray, nonstaining, nonsagging, gun grade polyurethane sealant, which cures at ambient temperature to a firm, flexible, resilient, tear-resistant rubber. Sealant shall comply with ASTM C920, Type M, Grade P, Class 25 for horizontal joints and Grade NS, Class 25 for vertical joints and be recommended by the manufacturer for continuous immersion in water. Troweling of sealants into joints will not be permitted. Sealant shall meet requirements in Table 031500-5.

TABLE 031500-5	
Characteristic or Parameter	Technical Requirements
Pot life	1 to 3 hours
Hardness	35 Shore A, +/- 5
Elongation	650 percent, ASTM D412
Tensile strength	200 psi, ASTM D412
Peel strength on concrete	No adhesion loss at 25 pounds
Temperature service range	40 to 167 degrees F
Immersion in water	Continuous

- B. For field molded sealant applications, use multi-component chemical resistant polysulfide sealant conforming to ASTM C920, Type M, Grade NS, Class 25.

2.05 EPOXY JOINT SEALANT

- A. 100 percent solids per ASTM D1259, two-part epoxy with an instantaneous Shore D hardness of 50 to 65 per ASTM D2240.

2.06 BACKING ROD FOR EXPANSION JOINTS

- A. Provide an extruded closed-cell polyethylene foam rod that is compressible, non-shrink, nonreactive with sealant, and non-absorptive material. The rod shall be 1/4-inch larger in diameter than the joint width. Where possible, provide full-length sections for the joint; minimize splices. The primer shall be the primer recommended in writing by the manufacturer.

2.07 BOND BREAKER TAPE

- A. Provide an adhesive-backed glazed butyl or polyethylene tape that will adhere to the premolded joint material or concrete surface. The tape shall be the same width as the joint. The tape shall be compatible with the sealant.

2.08 PREFORMED CONTROL JOINT

- A. One-piece, flexible, PVC joint former.
- B. One-piece steel strip with preformed groove.
- C. Provide the preformed control joint material in full-length unspliced pieces.

2.09 PREMOLDED JOINT FILLER FOR PAVEMENTS AND SLABS

- A. Joint filler shall be preformed, nonextruded type constructed of closed-cell neoprene conforming to ASTM D1752, Type I.
- B. Bituminous-type preformed expansion joint filler conforming to ASTM D994.

2.10 EXPANSION JOINT DOWELS

- A. Stainless steel bar dowels conforming to ASTM A276, Type 316.
- B. Thoroughly grease expansion joint dowels prior to placing adjoining wall or slab concrete.

2.11 STYROFOAM FILLER BLOCK

- A. Styrofoam filler blocks for future construction and expansion joints.

2.12 VOC LIMITS FOR SEALANTS, AND SEALANT PRIMERS

- A. VOC limits for sealants and sealant primers to comply with content limits when calculated according to 40 CFR 59, Subpart D (EPA Method 24) or applicable state and local codes containing more stringent requirements.

PART 3 - EXECUTION

3.01 PVC & TPER WATERSTOPS

- A. Heat splice at ends and intersections. Provide waterstops that provide a continuous, uninterrupted watertight diaphragm throughout the entire joint system above the high-water level and below grade. Splices at joints in waterstops shall be spliced together by qualified splicers using the approved splicing procedure to form a continuous watertight diaphragm.
- B. Construct forms for construction joints to prevent injury to water stops. Hold water stops securely in position in the construction joints as shown on Contract Drawings. Waterstops can be held in position through the use of wire ties, continuous bars, and rings. Install water stops in construction, contraction, and expansion joints as shown on Contract Drawings. In no case shall any fixed metal be continuous through an expansion joint.
- C. Use factory-made crosses, tees, and ells. Make field splices with a thermostatically controlled heating iron in conformance with the manufacturer's current recommendations. Allow at least 10 minutes before pulling or straining the new splice in any way. The finished splices shall provide a cross section that is dense and free of porosity with tensile strength of not less than 80 percent of the unspliced materials.

- D. Provide waterstops with an integral fastening system consisting of grommets or pre-punched holes.

3.02 JOINTS

- A. Make joints only at locations shown on the Contract Drawings or as permitted by the Construction Manager. Any addition or relocation of construction joints proposed by the Contractor must be submitted to the Construction Manager for written permission.
- B. Relocate additional joints where they least impair strength of the member. In general, locate joints within the middle third of spans of slabs and walls.
- C. Do not use horizontal joints within foundation mats, base slabs, footings, pile caps, slabs on grade, or elevated beams and slabs unless specifically shown on the Contract Drawings.
- D. Provide joints in concrete fills and toppings at the same location as the joints in the supporting concrete.
- E. Construction Joints
 1. Provide flat ribbed waterstops at construction joints where shown on Contract Drawings and specified herein.
 2. Allow 48 hours between pours of adjacent slabs.
 3. Where joint key ways are shown on Contract Drawings, form keyways by beveled strips or boards placed at right angles to the formed face. Except where otherwise shown on Contract Drawings or specified, keyways shall be at least 1-1/2 inches in depth over at least 25 percent of the width of the section.
 4. After the pour has been completed to the construction joint and the concrete has hardened, thoroughly clean the entire surface of the joint of surface laitance, loose concrete, foreign material, and expose clean aggregate by sandblasting the surface of construction joints before placing the new concrete. Cover horizontal construction joints with mortar. Spread uniformly and work thoroughly into irregularities of the surface. The water-cement ratio of the mortar in place shall not exceed that of the concrete to be placed, and the consistency of the mortar shall be suitable for placing and working.
 5. In case of emergency, place additional construction joints. (An interval of 45 minutes between two (2) consecutive batches of concrete shall constitute cause for an emergency construction joint.)

- F. Contraction Joints:

1. Provide center-bulb waterstop at contraction joints where shown on Contract Drawings and specified herein.
2. Where specifically noted on the Contract Drawings, coat the concrete surface with a bond breaker prior to placing new concrete against it. Avoid coating reinforcement or waterstops with bond breaker at these locations.
3. Full Contraction Joints:
 - a. Do not extend reinforcement or other embedded items bonded to the concrete (except dowels bonded on only one side of joint) continuously through any expansion joint.
 - b. Where shown on Contract Drawings, provide stainless steel expansion joint dowels. Secure tightly stainless steel expansion joints in forms with rigid ties. Orient dowels to permit joint movement.
4. Partial Contraction Joints:
 - a. Extend every other bar of reinforcement steel through partial contraction joints or as indicated on the Contract Drawings.

G. Control Joints:

1. Locate control joints as shown on the Contract Drawings.
2. Form control joints with control joint inserts or sawcuts.
3. For sawcutting:
 - a. Using early entry saws, saw joints in slabs before the formation of uncontrolled cracking (i.e., cracking that occurs at locations other than construction, control, or contraction joints) and as soon as the concrete has hardened sufficiently to permit cutting without chipping, spalling, or tearing.
 - b. Fill saw cut to full depth with elastomeric joint sealant for joints not exposed to vehicular traffic. Fill joints to full depth with epoxy joint sealant for joints exposed to vehicular traffic.
4. Unless noted otherwise on the Contract Drawings, total reduction in concrete member thickness shall be at least 1/4 the member thickness.

H. Expansion Joints:

1. Size and location of expansion joints shall be as shown on the Contract Drawings.

2. Provide center-bulb waterstop at expansion joints where shown on Contract Drawings and specified herein.
3. Do not extend reinforcement or other embedded items bonded to the concrete, except dowels bonded on only one side of joint continuously through any expansion joint.
4. Align stainless steel expansion joint dowels as indicated in the Contract Drawings. Secure tightly stainless steel expansion joint in forms with rigid ties. Orient dowels to permit joint movement.

3.03 INSTALLATION OF JOINT SEALANTS

- A. Immediately before installing the joint sealant, clean the joint cavity of all debris by sandblasting or power wire brushing and further cleaned using water, chemical solvents, or other means as recommended by the sealant manufacturer. The joints shall be dry prior to filling with sealant. Install bond breaker tape per manufacturer's instructions.
- B. Apply masking tape along the edges of the exposed surface of the exposed joints.
- C. Application criteria for the sealant materials, such as temperature and moisture requirements and primer cure time, shall be in accordance with the recommendations of the sealant manufacturer.
- D. After the joints have been prepared as described above, apply the joint sealant. Apply the primer, if required, and joint sealant only with the equipment and methods recommended by the joint sealant manufacturer.
- E. Trowel the joints smooth with a tuck-pointing tool wiped with a solvent recommended by the sealant manufacturer.
- F. After the sealant has been applied, remove the masking tape and any sealant spillage.

3.04 CONTRACT CLOSEOUT

- A. Provide in accordance with Section 017700.

END OF SECTION 031500

SECTION 032100 - REINFORCEMENT BARS

PART 1 - GENERAL

1.01 DESCRIPTION

- A. Provide concrete reinforcement as indicated and in compliance with Contract Documents:
 - 1. Section includes:
 - a. Reinforcement bars.
 - b. Welded wire reinforcement.
 - c. Reinforcement accessories.

1.02 PAYMENT

- A. No separate payment shall be made for performing any Work required under this Section. All costs for Work required by this Section shall be included in the applicable lump sum(s), unit price(s), or allowance(s) as set forth in Section 012901.

1.03 REFERENCES

- A. ASTM International (ASTM):
 - 1. A1064: Standard Specification for Carbon-Steel Wire and Welded Wire Reinforcement, Plain and Deformed, for Concrete.
 - 2. A615: Standard Specification for Deformed and Plain Billet Steel Bars for Concrete Reinforcement.
 - 3. A704: Standard Specification for Welded Steel Plain Bar or Rod Mats for Concrete Reinforcement.
 - 4. A706: Standard Specification for Low Alloy Steel Deformed and Plain Bars for Concrete Reinforcement.
 - 5. A775: Standard Specification for Epoxy Coated Reinforcement Steel Bars.
 - 6. A884: Standard Specification for Epoxy Coated Steel Wire and Welded Wire Reinforcement.
 - 7. E8: Tension Testing of Metallic Materials.
- B. American Concrete Institute (ACI):

1. 315: Details and Detailing of Concrete Reinforcement.
 2. 318: Building Code Requirements for Structural Concrete.
 3. 350: Building Code Requirements for Environmental Engineering Concrete Structures.
 4. SP-66: ACI Detailing Manual.
- C. Concrete Reinforcing Steel Institute (CRSI):
1. Manual of Standard Practice.
 2. Placing Reinforcing Bars.
- D. American Welding Society (AWS):
1. D1.4: Structural Welding Code, Reinforcement Steel.
- E. Where reference is made to one of the above standards, the version in effect at the time of bid opening shall apply.
- 1.04 RELATED SECTIONS
- A. General Conditions Article 4.7 – Shop Drawings and Other Submittals.
 - B. Section 012901 – Measurement and Payment.
 - C. Section 014300 – Quality Requirements.
 - D. Section 016100 – Control of Materials.
 - E. Section 017700 - Contract Closeout.
- 1.05 SUBMITTALS
- A. Unless otherwise acceptable to the Architect/Engineer, each submittal shall include reinforcement only for the individual structure to which it pertains.
 - B. Shop Drawings:
 - A. Submit bar lists and placing drawings for all reinforced concrete and masonry structures in accordance with General Conditions Article 4.7.
 1. Detail reinforcement in conformance with ACI SP-66.

2. Indicate on shop drawings bar bending details, lists, quantities of reinforcement, sizes, spacings, and locations of reinforcement and mechanical splices, if approved by Architect/Engineer, with identifying code marks to permit correct placement without reference to structural drawings. Indicate sizes, spacings, and locations of chairs, spacers, and hangers.
 3. Clearly indicate bar sizes, spacings, locations, and quantities of reinforcement steel and wire reinforcement, bending schedules, and supporting and spacing devices. Show joints with applicable joint reinforcement.
 4. Coordinate bar splicing and placement with Contractor's concrete placing schedule and joint locations. Do not add or delete joints without permission from the Architect/Engineer.
 5. Show wall reinforcement in elevation.
 6. Show slab reinforcement in plain view.
 7. Show location and size of all penetrations greater than 12 inches in diameter or least dimension of the opening with the corresponding added reinforcement around the penetrations.
 8. Clearly show marking for each reinforcement item.
 9. Indicate locations of reinforcement bar cut-offs, splices, and development lengths.
- C. Submit Certificates: Submit AWS qualification certificates for welders employed on the Work for the appropriate electrode and class of material. Maintain qualification and certification records at the job site, readily available for examination of test results.
- D. Submit certified copies of mill test reports of reinforcement analysis dated within the last three (3) months for each shipment of reinforcement with specific lots in shipments identified.
- E. Chemical composition of reinforcement steel: Ladle analysis indicating percentage of carbon, phosphorous, manganese, and sulfur present in steel.
- F. Where mechanical couplers are required or permitted to be used to splice reinforcement steel, submit Manufacturer's literature that contains instructions and recommendations for installation for each type of coupler used; certified test reports that verify the load capacity of each type and size of coupler used; and shop drawings that show the location of each coupler with details of how they are to be installed in the formwork. Physical properties of splicing sleeves shall include length, inside and outside diameters, and inside surface details. All mechanical splices shall test to a minimum of 125% capacity before being spliced.

1.06 QUALITY ASSURANCE

- A. Comply with requirements in Section 014300 and as specified.
- B. Do not fabricate reinforcement until shop and placement drawings have been reviewed and accepted by the Architect/Engineer.
- C. Perform concrete reinforcement work in accordance with, ACI 301, ACI SP-66, and ACI 318.
- D. The Contractor shall establish and maintain quality control for proper installation of all work covered in this section to assure compliance with contract specifications and maintain records of all quality control for all construction operations including but not limited to (1) minimum concrete cover of reinforcement steel; (2) number, size, and location of placement; (3) maintaining adequate splicing lengths where required; and (4) testing, inspection, and verification.
- E. Contractor shall employ an independent testing agency to visually inspect and test reinforcing steel welds in accordance with AWS D1.4.
- F. Contractor shall employ an independent testing agency to inspect each mechanical coupler and verify each component is installed in accordance with Manufacturer's instructions and ICC Evaluation Services Report or equivalent code agency report.

1.07 QUALIFICATIONS

- A. Welders: AWS qualified within previous twelve (12) months.

1.08 INSPECTION AND TESTING

- A. In no case shall any reinforcement steel be covered with concrete until the installation of the reinforcement has been observed by the Construction Manager and the Construction Manager's authorization to proceed with the concreting has been obtained. The Construction Manager shall be given 48 hours minimum prior notice of the readiness of placed reinforcement for observation. The forms shall be kept open until the Construction Manager has finished observations of the reinforcement steel.
- B. Provide Architect/Engineer with access to fabrication plant to facilitate inspection of reinforcement. Notify Architect/Engineer of commencement and duration of shop fabrication, with sufficient time to allow for proper inspection.

1.09 DELIVERY STORAGE AND HANDLING

- A. Comply with the requirements in Section 016100.
- B. Keep reinforcement steel free from mill scale, rust, dirt, grease, or other foreign matter.

- C. Ship and store reinforcement steel with bars of the same size and shape fastened in bundles with durable tags, marked in a legible manner with waterproof markings showing the same "mark" designations as those shown on the submitted placing drawings.
- D. Store reinforcement steel off the ground, protected from moisture, and kept free from dirt, oil, or other injurious contaminants.

1.10 EPOXY COATED REBARS

- A. Provide equipment for handling epoxy coated reinforcement steel with protected contact areas. Lift bundles of coated reinforcement at multiple pick-up points to minimize bar to bar abrasion from sags in bundles. Do not drop or drag coated reinforcement steel or bundles.
- B. Store coated reinforcement steel on protective cribbing.
- C. Coating damage due to handling, shipment, and placing need not be repaired in cases where damaged area is 0.1 sq. inch or smaller. Repair damaged areas larger than 0.1 sq. inch. Maximum amount of damage, including repaired and unrepaired areas, shall not exceed 2 percent of surface area of each bar.

PART 2 - PRODUCTS

2.01 REINFORCEMENT STEEL

- A. Reinforcement Steel: ASTM A615, 60 ksi yield strength; deformed billet steel bars, unfinished.
- B. Reinforcement Steel: ASTM A706, 60 ksi yield strength; deformed low-alloy steel bars, galvanized in accordance with ASTM A767, Class I epoxy coated in accordance with ASTM A775 finish as identified on the drawings.
- C. Welded Steel Wire Fabric: to ASTM A1064. Provide in flat sheets only.
- D. Epoxy Coated Reinforcement Steel: Deformed bars conforming to ASTM A615, Grade 60, with epoxy coating in accordance with ASTM A775 as identified on the drawings.
- E. Reinforcement Steel Plain Bar and Rod Mats: ASTM A704, ASTM A615, Grade 60; steel bars or rods, unfinished.
- F. Welded Wire Reinforcement:

1. Provide welded wire reinforcement conforming to ASTM A1064 in flat sheets and or epoxy coated in accordance with ASTM A884 Class A finish as required on the drawings.
2. Provide support bars and reinforcement bar supports as specified herein to obtain the concrete cover indicated.
3. Provide welded wire reinforcement heavier than W2.9 in flat sheets.

2.02 ACCESSORY MATERIALS

- A. Tie Wire: Minimum 16 gage black annealed type, epoxy coated when tying epoxy coated reinforcement.
- B. All chairs, bolsters, bar supports, and spacers shall conform to ACI SP-66.
- C. Chairs, Bolsters, Bar Supports, and Spacers: Sized and shaped for strength and support of reinforcement during concrete placement including load bearing pad on bottom of base slabs and slabs on grade to prevent puncturing the vapor retarder.
- D. Special Chairs, Bolsters, Bar Supports, and Spacers Adjacent to Weather Exposed Concrete Surfaces: Plastic coated steel and plastic type; size and shape.
- E. Use wire reinforcement supports coated with dielectric material including epoxy or other polymer for a minimum distance of 2 inches from the point of contact with epoxy-coated reinforcement.
- F. Provide 3 inch by 3 inch plain precast concrete blocks, precast concrete doweled blocks, or concrete brick for support of bottom reinforcement in foundation mats, base slabs, footings, pile caps, grade beams, and slabs on grade. Provide block thickness to produce concrete cover of reinforcement as indicated.
- G. Mechanical Couplers
 1. Use of mechanical couplers is subject to the approval of the Architect/Engineer.
- H. Provide epoxy for grouting reinforcement bars specifically formulated for such application for the moisture condition, application temperature, and orientation of the hole to be filled.

2.03 FABRICATION

- A. Fabricate concrete reinforcement in accordance with CRSI Manual of Standard Practice, ACI SP-66, ACI 318, ASTM A184.

- B. Weld reinforcement in accordance with AWS D1.4 only when permitted by the Architect/Engineer.
- C. Galvanized and Epoxy Coated Reinforcement: Clean surfaces, weld, and re-protect welded joint in accordance with Manufacturer's instructions.
- D. Locate reinforcement splices not indicated on Contract Drawings, at point of minimum stress. Review location of splices with Architect/Engineer.
- E. Obtain Architect/Engineer's approval for locations of reinforcement splices other than those shown on placing Contract Drawings.
- F. Cold bend bars: Do not straighten or rebend bars.
- G. When bending, apply slow, steady pressure. Replace bars that develop cracks or splits. Do not heat reinforcement steel to bend or straighten.
- H. No steel bars shall be bent after being partially embedded in concrete unless indicated on the Drawings or authorized by the Architect/Engineer. No steel bars partially embedded in concrete shall be field bent unless otherwise authorized by the Architect/Engineer.
- I. Bend bars around a revolving collar having a diameter of not less than that recommended by the ACI 318.
- J. Cut bar ends that are to be butt spliced or threaded by saw cutting. Terminate such ends in flat surfaces within 1-1/2 degrees of a right angle to the axis of the bar.
- K. All hooks and bends shall be in accordance with ACI 318.
- L. Apply epoxy coating to the deformed reinforcement bars under the following guidelines:
 - 1. Shop bend reinforcement before coating.
 - 2. Maintain thickness of the coating at 7 mil +/- 2 mil.
 - 3. Blast clean bars to near white metal before coating.
 - 4. Clean and coat cut ends.
 - 5. Patch damaged areas immediately before visible rust has formed. Patch at the fabrication plant.
 - 6. Provide coatings free from holes, voids, contamination, cracks, and damaged areas. Check coatings visually after curing.

7. Not more than two (2) "holidays" (pinholes not visible to the naked eye) per 12-inch of bar are allowed in the coatings. Test coatings with a 67.5 volt holiday detector in accordance with the Manufacturer's instructions.
8. Check each production lot and certify that all the coated bars are supplied in the fully cured condition.
9. Evaluate the flexibility of the coating by selecting bars from production lots bent 120 degrees (after rebound) around a 6-inch diameter mandrel. Make the bend at a uniform rate in not more than one (1) minute. The longitudinal deformations may be placed in a plane perpendicular to the mandrel radius, and the test specimens shall be at a constant temperature between 70 degrees F and 85 degrees F throughout the bend test.
10. If no cracks in the coating of the bent specimen are visible to the naked eye, the coating is satisfactory.

PART 3 - EXECUTION

3.01 INSTALLATION

- A. Place, support, and secure reinforcement against displacement. Do not deviate from required position. Place reinforcement a minimum of 2 inches clear of any metal pipe or fittings. Reinforcement and accessories shall be placed as specified herein and shown on the Drawings and on approved shop drawings. Fabrication and placement details of steel and accessories not specified or shown shall be in accordance with ACI SP-66 and ACI 318. Steel reinforcement shall be fabricated to the shapes and dimensions shown and placed where indicated within specified tolerances and adequately supported during concrete placement.
- B. Bars shall be spaced as indicated on the Drawings or as otherwise directed. The spacing between adjacent bars and the distance between layers of bars may not vary from the indicated position by more than one (1) bar diameter or more than 1 inch, whichever is less.
- C. Position dowels accurately. Rigidly support, align, and securely tie dowels normal to the concrete surface before concrete placement. Setting dowels into wet concrete is prohibited.
- D. Position wall dowels projecting from base slabs on grade with templates or guides held in place above the concrete placement line. Position the templates to obtain the required clearance between the dowels and the face of the walls.

- E. Bars additional to those indicated that may be found necessary or desirable by the Contractor for the purpose of securing reinforcement in position shall be provided by the Contractor at no additional cost to the DEP.
- F. Do not extend continuous reinforcement or other fixed metal items through expansion joints. Provide 2 inches clearance from each face of expansion joint.
- G. Provide additional reinforcement bars to support top reinforcement in slabs. Do not shift reinforcement bars from positions in upper layers to positions in lower layers as a substitute for additional support bars.
- H. Support and tie reinforcement steel in accordance with CRSI “Placing Reinforcement Bars” with maximum spacing of 4 feet-0 inches.
- I. Tie reinforcement steel at intersections in accordance with CRSI “Placing Reinforcement Bars”:
 - 1. Maximum tie spacing for footings, walls and columns: every third intersection or 3 feet-0 inches.
 - 2. Maximum spacing for slabs and other work: every fourth intersection or 3 feet-0 inches.
 - 3. Tie a minimum of 25 percent of all intersecting bars in foundation mats, base slabs, footings, pile caps, slabs on grade, and elevated slabs.
 - 4. Secure all dowels in place before placing concrete.
 - 5. Tie wires shall be bent away from the forms and from finished concrete surfaces in order to provide the required concrete coverage.
- J. Locate reinforcement to avoid interference with items drilled in later, such as concrete anchors.
- K. Mechanical coupler systems may be substituted for dowels at Contractor’s option when permitted by the Architect/Engineer.
- L. Provide additional reinforcement bars to support ties and stirrups in beams where top reinforcement is not continuous.
- M. Securely support and tie reinforcement steel to prevent movement during concrete placement.
- N. Unless otherwise shown on the Contract Drawings or permitted by the Architect/Engineer, do not bend or twist reinforcement bars that project from in-place concrete.

- O. Do not weld reinforcement steel bars (including tack welded) either during fabrication or erection unless specifically shown on the Contract Drawings or specified herein, or unless prior written permission has been obtained from the Architect/Engineer. Immediately remove bars that have been welded, including tack welds, without such permission from the Work. Comply with AWS D1.4 when welding of reinforcement is or called for.
- P. Reinforcement steel interfering with the location of other reinforcement steel, conduits or embedded items may be moved 1 inch or one bar diameter, whichever is less. Make greater displacement of bars to avoid interference only with the permission of the Architect/Engineer. Do not cut reinforcement to install inserts, conduits, mechanical openings, or other items without the prior permission from the Architect/Engineer.
- Q. Reinforcement shall be clean and free from loose mill scale, dirt, grease, oil, form release agent, dried concrete, or any material reducing bond with concrete.
- R. Setting bars and welded wire reinforcement on layers of fresh concrete as the work progresses or adjusting reinforcement during the placement of concrete is prohibited.
- S. Provide and place safety caps on all exposed ends of vertical reinforcement that pose a danger to injury or life safety.

3.02 WELDED WIRE REINFORCEMENT

- A. Extend welded wire reinforcement to within 2 inches of edges of slab or section. Lap sheets at least 12 inches or two wire spaces, whichever is greater, at ends and edges and wire tightly together. Stagger end laps.
- B. Unless shown otherwise on Drawings, place welded wire reinforcement in slabs on grade between the upper third point and mid-point of slab. Placing welded wire reinforcement on the subgrade and pulling it up during concrete placement is not permitted.
- C. Support welded wire reinforcement placed over the ground on wired concrete blocks (dobies) spaced not more than 3 feet on centers in any direction.
- D. Support welded wire reinforcement placed over horizontal forms on slab bolsters spaced not more than 30 inches on center.

3.03 CONCRETE COVER OVER REINFORCEMENT BARS

- A. The minimum and maximum concrete cover of main reinforcement steel shall be as shown on the Contract Drawings. The concrete tolerances shall be as follows:

MINIMUM COVER	VARIATION
6 inches	plus ½ inch
4 inches	plus 3/8 inch
3 inches	plus 3/8 inch

2 inches	plus ¼ inch
1-1/2 inch	plus ¼ inch
1 inch	plus 1/8 inch
¾ inch	plus 1/8 inch

3.04 REINFORCEMENT AROUND OPENINGS AND PENETRATIONS

- A. Accommodate placement of formed openings and penetrations.
- B. Unless specific additional reinforcement around openings and penetrations is as shown on the Contract Drawings, provide additional reinforcement steel on each side of opening or penetration equivalent to one half of the cross-sectional area of the reinforcement steel interrupted by an opening or penetration. The bars shall have sufficient length to be fully developed at each end beyond the opening or penetration.
- C. Refer to details on Contract Drawings for additional diagonal bars around openings or penetrations and bar extension length on each side of openings or penetrations.
- D. Where welded wire fabric is used, provide extra reinforcement using fabric or deformed bars around opening or penetration.

3.05 SPLICING OF REINFORCEMENT

- A. Except as provided herein or otherwise shown on the drawings, all splicing shall be in accordance with approved splicing procedures and requirements of ACI 318.
- B. Splices may be used to provide continuity due to bar length limitations. Do not splice reinforcement that is detailed to be continuous in the Contract Drawings.
- C. Stagger bar splices.
- D. Provide tension lap splices at all laps in compliance with ACI 318, except when otherwise shown on the Drawings. Class A splices may be used when 50 percent or less of the bars are spliced within the required lap length. Use Class B splices at all other locations.
- E. Lap splices shall be used only for bars smaller than size No. 14 bar.
- F. Make splices for reinforcement in tension tie members, with a full mechanical or full welded splice and staggered at least 30 inches.
- G. Butt splices in reinforcement steel shall be as specified or as shown on the drawings. Bars may be spliced at alternate or additional locations at no additional cost to the DEP, subject to the approval of the Architect/Engineer.
- H. Make reinforcement continuous through construction joints.

- I. Reinforcement may be spliced at construction joints provided that entire lap is placed within only one concrete placement.

3.06 ACCESSORIES

- A. Provide accessories such as chairs, chair bars, and the like in sufficient quantities and strength to adequately support the reinforcement and prevent its displacement during the erection of the reinforcement and the placement of concrete.
- B. Use precast concrete blocks where the reinforcement steel is to be supported over soil.
- C. Provide stainless steel bar supports or steel chairs with plastic tips where the chairs are set on forms for a concrete surface that will be exposed to weather, high humidity, or liquid (including bottom of slabs over liquid containing areas), unless otherwise noted on Contract Documents.
- D. Do not use metal chairs, ferrous clips, nails, etc. that extend to the surfaces of the concrete. Do not use stones, brick, or wood block supports.
- E. Do not use alternate methods of supporting top steel in slabs, such as steel channels supported on the bottom steel or vertical reinforcement steel fastened to the bottom and top mats, unless permitted by the Architect/Engineer.
- F. Mechanical Couplers:
 1. Mechanical butt-splices in reinforcement steel shall be as specified, shown on the drawings, or as directed by the Architect/Engineer. Except as provided herein, all splicing shall be in accordance with approved splicing procedures and the requirements of ACI 318. Bars larger than No. 11 shall be spliced with mechanical connectors or butt-welded in accordance with ACI 318. The splice shall be submitted to the Architect/Engineer for approval.
 2. Couplers that are located at a joint face can be a type that can be set either flush or recessed from the face as indicated.
 3. Seal couplers during concrete placement to completely eliminate concrete or cement paste from entering.
 4. Recess couplers intended for future connections a minimum of 1/2 inch from the concrete surface. After the concrete is placed, plug the coupler with plastic plugs that have an O-ring seal and the recess filled with sealant to prevent any contact with water or other corrosive materials.
 5. Unless indicated otherwise, provide mechanical coupler spacing and size to match the spacing and size of the reinforcement indicated for the adjacent section.

3.07 PLACEMENT OF EPOXY COATED REINFORCEMENT

- A. Pad bundling bands and lift with strong backs or a platform bridge to prevent abrasion of bars by sagging in the bundles.
- B. Do not drop or drag bars or bundles.
- C. Patch and touch up coated bars after placing. Do not place concrete until patching is reviewed by the Construction Manager.
- D. In systems for lifting, transporting, and storing coated bars, pad areas in contact with the bars.

3.08 FIELD QUALITY CONTROL

- A. Remove reinforcement with kinks or bends not shown on shop or placement drawings. Remove such reinforcement from job site and replace with new fabricated steel. Do not field bend reinforcement unless reinforcement is indicated or specified to be field bent.
- B. Protect reinforcement from rusting, deforming, bending, kinking, and other injury. Clean in-place reinforcement that has rusted or been splattered with concrete using sand or water blasting prior to incorporation into the Work.

3.09 CONTRACT CLOSEOUT

- A. Provide in accordance with Section 017700.

END OF SECTION 032100

NO TEXT ON THIS PAGE

SECTION 033000 - CAST-IN-PLACE CONCRETE

PART 1 - GENERAL

1.01 DESCRIPTION

- A. Provide cast-in-place concrete as indicated and in compliance with Contract Documents.

1.02 PAYMENT

- A. No separate payment shall be made for performing any Work required under this Section. All costs for Work required by this Section shall be included in the applicable lump sum(s), unit price(s), or allowance(s) as set forth in Section 012901.

1.03 REFERENCES

- A. American Concrete Institute (ACI):

1. 117: Standard Specifications for Tolerances for Concrete Construction and Materials.
2. 211.1: Standard Practice for Selecting Proportions for Normal, Heavyweight, and Mass Concrete.
3. 214R: Recommended Practice for Evaluation of Strength Test Results of Concrete.
4. 301: Standard Specifications for Structural Concrete.
5. 304R: Guide for Measuring, Mixing, Transporting and Placing Concrete.
6. 304.2R: Placing Concrete by Pumping Methods.
7. 305R: Hot Weather Concreting.
8. 306R: Cold Weather Concreting.
9. 308: Standard Practice for Curing Concrete.
10. 309R: Guide for Consolidation of Concrete.
11. 311.4R: Guide for Concrete Inspection.
12. 318: Building Code Requirements for Structural Concrete.

- B. ASTM International (ASTM):

1. A123: Standard Specification for Zinc (Hot-Dip Galvanized) Coatings on Iron and Steel Products.
2. A153: Standard Specification for Zinc Coating (Hot-Dip) on Iron and Steel Hardware.
3. C31: Standard Practice for Making and Curing Concrete Test Specimens in the Field.
4. C33: Standard Specification for Concrete Aggregates.
5. C39: Standard Test Method for Compressive Strength of Cylindrical Concrete Specimens.
6. C40: Standard Test Method for Organic Impurities in Fine Aggregates for Concrete.
7. C42: Standard Test Method for Obtaining and Testing Drilled Cores and Sawed Beams of Concrete.
8. C87: Standard Test Method for Effect of Organic Impurities in Fine Aggregate on Strength of Mortar.
9. C88: Standard Test Method for Soundness of Aggregates by Use of Sodium Sulfate or Magnesium Sulfate.
10. C94: Standard Specification for Ready-Mixed Concrete.
11. C109: Standard Test Method for Compressive Strength of Hydraulic Cement Mortars (Using 2-in Cube Specimens).
12. C123: Standard Test Method for Lightweight Particles in Aggregate.
13. C136: Standard Test Method for Sieve Analysis of Fine and Coarse Aggregates.
14. C138: Standard Test Method for Unit Weight, Yield, and Air Content (Gravimetric) of Concrete.
15. C143: Standard Test Method for Slump of Hydraulic Cement Concrete.
16. C150: Standard Specification for Portland Cement.
17. C157: Standard Test Method for Length Change of Hardened Hydraulic Cement, Mortar and Concrete.
18. C171: Standard Specification for Sheet Materials for Curing Concrete.

19. C172: Standard Practice for Sampling Freshly Mixed Concrete.
20. C192: Standard Practice for Making and Curing Concrete Test Specimens in the Laboratory.
21. C231: Standard Test Method for Air Content of Freshly Mixed Concrete by the Pressure Method.
22. C260: Standard Specification for Air-Entraining Admixtures for Concrete.
23. C289: Standard Test Method for Potential Alkali-Silica Reactivity of Aggregates (Chemical Method).
24. C295: Standard Guide for Petrographic Examination of Aggregates for Concrete.
25. C309: Standard Specification for Liquid Membrane-Forming Compounds for Curing Concrete.
26. C311: Standard Test Methods for Sampling and Testing Fly Ash or Natural Pozzolans for Use as a Mineral Admixture in Portland Cement Concrete.
27. C494: Standard Specification for Chemical Admixtures for Concrete.
28. C595: Standard Specification for Blended Hydraulic Cements.
29. C618: Standard Specification for Coal Fly Ash and Raw or Calcined Natural Pozzolan for Use as a Mineral Admixture in Portland Cement Concrete.
30. C881: Standard Test Method for Epoxy Resin Base Bonding Systems for Concrete.
31. C882: Standard Test Method for Bond Strength of Epoxy Resin Systems Used with Concrete by Slant Shear.
32. C989: Standard Specification for Ground Granulated Blast-Furnace Slag for Use in Concrete and Mortars.
33. C1017: Standard Specification for Chemical Admixtures for Use in Producing Flowing Concrete.
34. C1059: Standard Specification for Latex Agents for Bonding Fresh to Hardened Concrete.
35. C1064: Standard Test Method for Temperature of Freshly Mixed Portland Cement Concrete.
36. C1107: Standard Specification for Packaged Dry, Hydraulic-Cement Grout (Non shrink).

37. C1116: Standard Specification for Fiber Reinforced Concrete.
 38. C1240: Standard Specification for Silica Fume for Use as a Mineral Admixture in Hydraulic-Cement Concrete, Mortar, and Grout.
 39. D75: Standard Practice for Sampling Aggregates.
 40. E154: Test Methods for Water Vapor Retarders Used in Contact with Earth Under Concrete Slabs, on Walls, or as Ground Cover.
 41. E1745: Standard Specification for Water Vapor Retarders Used in Contact with Soil or Granular Fill under Concrete Slabs.
 42. E329: Standard Specification for Agencies Engaged in the Testing and/or Inspection of Materials used in Construction.
- C. American Association of State Highway and Transportation Officials (AASHTO):
1. M182: Standard Specification for Burlap Cloth Made from Jute or Kenaf and Cotton Mats.
- D. National Sanitation Foundation (NSF):
1. 61: Drinking Water System Components – Health Effects.
- E. National Institute of Standards and Technology (NIST)
1. NIST Handbook 44: Specifications, Tolerances, and other Technical Requirements for Weighing and Measuring Devices.
- F. U.S. Army Corps of Engineers (USACE)
1. COE CRD-C 143: Specifications for Meters for Automatic Indication of Moisture in Fine Aggregates.
 2. COE CRD-C 521: Standard Test Method for Frequency and Amplitude of Vibrators for Concrete.
- 1.04 RELATED SECTIONS
- A. General Conditions Article 4.7 – Shop Drawings and Other Submittals
 - B. Section 012901 – Measurement and Payment.
 - C. Section 014300 - Quality Requirements.
 - D. Section 016100 – Control of Materials.

- E. Section 017700 - Contract Closeout.
- F. Section 031000 - Concrete Formwork.
- G. Section 031500 - Concrete Joints and Accessories.
- H. Section 032100 - Reinforcement Bars.
- I. Section 312300 - Excavation and Fill.

1.05 SUBMITTALS

- A. Submit the following shop drawings in accordance with General Conditions Article 4.7.
- B. Product Data:
 - 1. Concrete mixtures: For each concrete mixture, submit alternate design mixtures when characteristics of materials, project conditions, weather, test results, or other circumstances warrant adjustment. Provide concrete mixture quantities of all ingredients per cubic yard including the nominal maximum size aggregate. Proportions shall indicate the mass of cement, pozzolan and slag cement when used, and water; the mass of aggregates in a saturated surface-dry condition; and the quantities of admixtures including the hydration stabilizer at the required dosage, if one is to be used. The submission shall be accompanied by test reports from a laboratory complying with ASTM C1077 which show that proportions thus selected will produce concrete of the qualities indicated. Mix proportions, exact slump, and exact air content shall be reported for each concrete cylinder used to develop the mix design. No substitution shall be made in the source or type of materials used in the work without additional tests to show that the quality of the new materials and concrete are satisfactory.
 - 2. Aggregate proportions.
 - 3. Batch plant.
 - 4. Concrete mixers.
 - 5. Placing equipment and methods.
 - 6. Non-shrink grout.
 - 7. Admixtures and curing materials. In addition to general product data, manufacturer's specifications and instructions including Material Safety Data Sheets (MSDS) shall be provided. Manufacturer's certification of compatibility of all admixtures shall also be provided.

8. Provide epoxy bounding compound manufacturer's specific instructions for use. Provide manufacturer's data sheets as to the stability of product to meet job requirements with regard to surface, pot life, set time, vertical or horizontal application, and forming restrictions.
- B. Submit samples for the following concrete mixture constituents:
1. Aggregate.
 2. Surface retarder.
- C. Shop Drawings:
1. Provide certificate that cement used complies with ASTM C150 and these specifications.
 2. Provide certificates that aggregates comply with ASTM C33 and contain less than 0.25 percent asbestos by weight or volume. Submit gradation analysis with concrete mix designs.
 3. Provide certificate of compliance with these specifications from the manufacturer of the concrete admixtures.
 4. For each formulation of concrete proposed, provide concrete mix designs and laboratory 7-day and 28-day compressive tests, or submit test results of 7- and 28-day compressive tests of the mix where the same mix has been used on two (2) previous projects in the past twelve months.
 5. For each formulation of concrete proposed, prepare mix designs in accordance with ACI 318, Chapters 4 and 5, except as modified herein. Submit mix design for review by the Construction Manager at least 15 days before placing of any concrete.
 6. Proposed special procedures for protection of concrete under wet weather placement conditions.
 7. Proposed special procedures for protection and curing of concrete under hot and cold weather conditions.
 8. The method and equipment proposed for construction joint preparation and waste disposal.
 9. Proposed curing medium and methods to be used.
 10. The Contractor shall submit statements that the concrete testing technicians and the concrete construction inspectors meet the qualification requirements of paragraph 3.08.D "Concrete Testing".

11. Cementitious materials will be accepted on the basis of the manufacturer's certification of compliance, accompanied by mill test reports, stating that materials meet the requirements of the specification under which they are furnished. Certification and mill test reports shall be from samples taken from the particular lot furnished. If average values are submitted, they shall be furnished with daily test results. If a blended product meeting ASTM C 595 is to be used, the manufacturer shall also certify in writing that the amount of pozzolan or slag in the finished cement will not vary more than plus or minus 5.0 mass percent of the finished cement from lot to lot or within a lot. No cementitious materials shall be used until notice of acceptance has been given by the Construction Manager.
12. Impervious sheet curing materials shall be certified for compliance with all specification requirements.
13. Air-entraining admixture shall be certified for compliance with all specification requirements.
14. Other chemical admixtures shall be certified for compliance with all specification requirements.
15. Membrane-forming curing compound shall be certified for compliance with all specification requirements.
16. Steel Reinforcement Shop Drawings as defined in Section 032100.
17. Formwork Shop Drawings as defined in Section 031000.
18. Construction Joint Layout. Indicate proposed construction joints required to construct the structure. Joint construction shall follow the provisions given in Section 031500.

D. Test and Evaluation Reports

1. Provide qualifications for Concrete Testing Service.
2. Provide certified copies of laboratory test reports, including mill tests and all other test data, for Portland cement, blended cement, pozzolan, ground granulated blast furnace slag, aggregate, admixtures, and curing compound proposed for use on this Project.
3. Test results and inspection reports shall be submitted daily.

E. Manufacturers' Instructions

1. Provide epoxy bonding compound manufacturer's specific instructions for use. Provide manufacturer's data sheets as to suitability of product to meet job

requirements with regard to surface, pot life, set time, vertical or horizontal application, and forming restrictions.

F. Field Quality Control Submittals

1. Provide delivery tickets for ready-mix concrete or weighmasters certificate per ASTM C94, including weights of cement and each size aggregate, amount of water added at the plant, and record of pours. Record the amount of water added on the job on the delivery ticket. Water added at the plant shall account for moisture in both coarse and fine aggregate.

G. Concrete Wall Mock-up

1. Construct two wall mock-ups, one in the south, one in the north, providing a representative sample of the finish surfaces for the cast-in place concrete wall. Each finish specified on the drawings shall be incorporated into the mock-up in a manner that meets the approval of the Engineer. Each mock-up shall be not less than 10' long by 8' high, and be in place for the duration of the wall construction. The wall mock-ups shall be placed in locations that are suitable for inspection by the Engineer and the CMF team. Payment of the mock-up shall be deemed incidental to the concrete wall item. No additional payment shall be made for the wall mock-up.

1.06 QUALITY ASSURANCE

A. Provide in accordance with Section 014300.

B. Concrete will be tested as identified in the mix performance part of this specification, which includes Paragraph 1.05.C “Testing of Ready-Mix Concrete”, and Paragraph 3.12 “Concrete Quality Assurance”.

C. Testing of Ready-Mix Concrete

1. Testing will be performed by an independent testing agency employed by the Contractor to perform sampling and material evaluation tests and to design concrete mixtures. Accreditation or validation by the National Voluntary Laboratory Accreditation Program, American Association for Laboratory Accreditation, ASSHTO Accreditation Program, or other nationally recognized independent authority shall be submitted on laboratories that are performing any testing required for this project. Documentation shall be submitted within 30 days prior to performance of any testing and shall be specific as to testing equipment and procedures that are covered. Testing reports shall be provided to document testing as outlined in ASTM C94.
2. Testing of Ready-Mix Concrete trucks on delivery will include:

- a. Slump.
 - b. Air content.
 - c. Wet density.
 - d. Concrete temperature.
3. Samples will be cast for laboratory testing for:
- a. Compressive strength.
4. Initially, six (6) samples will be cast and one (1) three (3) day, one (1) seven (7) day, two (2) fourteen (14) day, and two (2) twenty-eight (28)-day compression samples will be tested. Upon achieving acceptable results, the testing will be reduced one (1) cylinder at seven (7) days and one (1) cylinder at fourteen (14) days for information; test two (2) cylinders at 28 days for acceptance; and hold two (2) reserve cylinders for verification This process shall be applied to each class or formulation of concrete used on the project.
5. Samples may be taken for other testing as determined by the Construction Manager at no additional cost to the DEP.
6. Copies of the results of all concrete testing carried out by the Contractor will be submitted to the Construction Manager no later than seven (7) days after testing.
7. The provision of the test results from the independent testing agency does not relieve the Contractor of the responsibility to furnish materials and construction in compliance with the performance requirements of the Contract Documents.
8. The Contractor shall take samples and carry out testing as part of their quality control procedures to verify that the concrete satisfies the performance requirements set out in these specifications.
- D. Unless otherwise indicated, materials, workmanship, and practices shall conform to the following standards:
1. ACI 301, "Structural Concrete for Buildings. "
 2. ACI 318, "Building Code Requirements for Reinforced Concrete. "
 3. ANSI/NSF 61, "Drinking Water System Components – Health Effects. "
- E. Where provisions of pertinent codes and standards conflict with this specification, the more stringent provisions govern.

- F. Concrete not meeting the minimum specified 28-day design strength shall be cause for rejection and removal from the work.
- G. Perform concrete work in conformance with ACI 301, unless otherwise specified.
- H. Do not use admixtures, including calcium chloride, which will cause accelerated setting of cement in concrete.
- I. Do not place concrete until design mix, material tests, and trial concrete batch mix compression test results are accepted by the Construction Manager.
- J. Employ an independent testing laboratory, acceptable to the Construction Manager, to develop concrete mix designs and testing. Concrete testing shall be performed by an ACI Concrete Field Technician, Grade I or equivalent.
- K. The Contractor shall employ an independent testing laboratory, acceptable to the Construction Manager, to test conformity of materials to specifications. Concrete testing shall be performed by an ACI Concrete Field Technician, Grade I or equivalent. Allow free access to obtain test samples.
- L. Methods of Sampling and Testing:
 - 1. Fresh Concrete Sampling: ASTM C172.
 - 2. Specimen Preparation: ASTM C31.
 - 3. Compressive Strength: ASTM C39.
 - 4. Air Content: ASTM C231.
 - 5. Slump: ASTM C143.
 - 6. Temperature: ASTM C1064.
 - 7. Unit Weight: ASTM C138.
 - 8. Obtaining Drilled Cores: ASTM C42.
- M. Acceptance of Structure: Acceptance of completed concrete work requires conformance with dimensional tolerances, appearance, and strength as indicated or specified.
- N. Hot weather concrete to conform to ACI 305R and as specified herein.
- O. Cold weather concrete to conform to ACI 306R and as specified herein.
- P. Reject concrete delivered to job site that exceeds the time limit or temperature limitations specified.

Q. Do not place concrete in water or on frozen or uncompacted ground.

R. Workability

1. Concrete shall be of such consistency and composition that it can be worked readily into the forms and around the reinforcement without excessive vibrating and without permitting the materials to segregate or free water to collect on the surface.
2. Concrete mix shall be designed to reflect the method of transportation to the project site.
3. Adjust the proportions to secure a plastic, cohesive mixture, and one that is within the specified slump range.
4. To avoid unnecessary changes in consistency, obtain the aggregate from a source with uniform quality, moisture content, and grading. Handle materials to minimize variations in moisture content that would interfere with production of concrete of the established degree of uniformity and slump.

1.07 DELIVERY, STORAGE, AND HANDLING

- A. Provide in conformance with Section 016100 and as specified herein.
- B. Deliver concrete to discharge locations in watertight agitator or mixer trucks without altering the specified properties of water-cement ratio, slump, air entrainment, temperature, and homogeneity.
- C. Reject concrete not conforming to specification, unsuitable for placement, exceeding the time or temperature limitations, or not having a complete delivery batch ticket.

1.08 SITE CONDITIONS

- A. Do not place concrete until conditions and facilities for making and curing control test specimens are in compliance with ASTM C 31 and as specified herein.
- B. The definitions of the terms used in the following tables shall be as defined in ACI 117. Level and grade tolerance measurements of slabs shall be made as soon as possible after finishing. When forms or shoring are used, the measurements shall be made prior to removal. Tolerances are not cumulative. The most restrictive tolerance controls. Tolerances shall not extend the structure beyond legal boundaries. Except as specified otherwise, plus tolerance increases the amount or dimension to which it applies, or raises a level alignment, and minus tolerance decreases the amount or dimension to which it applied or lowers a level alignment. A tolerance without a sign means plus or minus. Where only one signed tolerance is specified, there is no limit in the other direction.

TOLERANCES FOR FOUNDATIONS

(1) Lateral alignment Eccentricity measured from the center of gravity of footing as cast to the center of gravity as specified; 0.02 times width of footing in direction of misplacement but not more than.	2 inches
Supporting masonry construction	1/2 inch
(2) Level alignment Top of footings supporting masonry	1/2 inch
Top of other footings	plus 1/2 inch minus 2 inch
(3) Cross-sectional dimensions Horizontal dimension of formed members	plus 2 inch minus 1/2 inch
Horizontal dimensions of unformed members cast against soil 2 feet or less	plus 3 inch minus 1/2 inch
Vertical dimension (thickness)	minus 5 percent
(4) Relative alignment Slope of footing side and top surfaces with respect to the specified plane	1 inch max. per 10 feet

TOLERANCE FOR FORMED CONCRETE SURFACES

(1)	Vertical alignment Formed surfaces slope with respect to the specified plane. Vertical alignment of outside corner of exposed corner columns and control joint grooves in concrete exposed to view.	1/4-inch max. in 10 feet
	All other conditions	3/8-inch max. in 10 feet
(2)	Abrupt variation The offset between concrete surfaces for the following classes of surface:	
	Class A	1/8 inch
	Class B	1/4 inch
	Class D	1 inch
(3)	Gradual variation	
	Surface finish tolerances as measured by placing a freestanding (unleveled), 5-foot straightedge for plane surface or curved template for curved surface anywhere on the surface and allowing it to rest upon two (2) high spots within 72 hours after concrete placement. The gap at any point between the straightedge or template and the surface shall not exceed:	
	Class A	1/8 inch
	Class B	1/4 inch
	Class D	1 inch

1.09 APPEARANCE

- A. Permanently exposed surfaces shall be cleaned, if stained or otherwise discolored, by a method that does not harm the concrete and that is approved by the Construction Manager.

PART 2 - PRODUCTS

2.01 MATERIALS

- A. Cement:
 1. Portland Cement, ASTM C150, Type II; or blended hydraulic cement, ASTM C595, Type IP (MS) except that the maximum amount of C3A in Type I shall be 15 percent.
 2. Use only one brand of cement from the same source in any individual structure. Use no cement that has become damaged, partially set, lumpy, or caked. Reject the

entire contents of the sack or container that contains such cement. Use no salvaged or reclaimed cement.

3. Maximum tricalcium aluminate shall not exceed 8 percent. The maximum percent alkalis shall not exceed 0.6 percent.

B. Fly Ash:

1. Provide fly ash conforming to the following requirements:
 - a. Class F fly ash conforming to ASTM C 618 for chemical and physical properties.
 - b. Supplemental requirements in percent:
 - (1) Maximum carbon content: 3 percent.
 - (2) Maximum sulfur trioxide (SO₃) content: 4 percent.
 - (3) Maximum loss on ignition: 3 percent.
 - (4) Maximum water requirement (as a percent of control): 100 percent.
 - (5) Fineness, maximum retained on No. 325 sieve: 25 percent.

C. Ground Granulated Blast Furnace Slag (GGBF):

1. GGBF, when used, shall meet the requirements of ASTM C989, Grade 100 or Grade 120.

D. Fine Aggregates:

1. Clean, sharp, natural sand conforming to requirements of ASTM C33 with a fineness modulus between 2.50 and 3.0.

E. Coarse Aggregate:

1. Well graded crushed stone, natural rock conforming to requirements of ASTM C33, and shall contain less than 0.25 percent asbestos by weight or volume.
2. Limit deleterious substances in accordance with ASTM C33, Table 3, Severe Weathering Regions, limit clay lumps not to exceed 1.0 percent by weight, and limit loss when tested for soundness using magnesium sulfate to 12 percent.

F. Water and Ice:

1. Use water and ice free from injurious amounts of oil, acid, alkali, salt, organic matter, or other deleterious substances and conforms to requirements of ASTM C94.
2. Water shall not contain more than 500 ppm of chlorides or more than 500 ppm of sulfate.
3. Heat or cool water to obtain concrete temperatures specified, and in conformance with ACI 305R and ACI 306R.

G. Concrete Admixtures:

1. Maintain compressive strength and maximum water-cement ratios specified in Table 033000-1 when using admixtures. Include admixtures in solution form in the water-cement ratio calculations.
2. Do not use any admixture that contains chlorides or other corrosive elements in any concrete. Admixtures shall be nontoxic after 30 days.
3. Use admixtures in compliance with the manufacturer's printed instructions. The manufacturer shall certify the compatibility of multiple admixtures used in the same mix.
4. Do not use admixtures in greater dosages than recommended by manufacturer.
5. Air Entrainment:
 - a. Class A concrete; an air-entraining admixture conforming to ASTM C260.
 - b. Adjust the admixture content to accommodate fly ash or pozzolan requirements, and other admixtures when used, in order to obtain air content in the specified ranges under field conditions.
6. Water Reducing:
 - a. Class A concrete; a water-reducing admixture conforming to ASTM C494, Type A and compatible with the air-entraining admixtures. The amount of admixture added to the concrete shall be in accordance with the manufacturer's recommendations.
7. Water Reducing and Retarding:
 - a. Class A concrete; a water-reducing and retarding admixture conforming to ASTM C494, Type D and compatible with the air-entraining admixtures. The amount of admixture added to the concrete shall be in accordance with the manufacturer's recommendations.

8. High-Range Water-Reducing Admixture (Superplasticizer):
 - a. Class A concrete; a High-Range water-reducing admixture conforming to ASTM C494, Type F or ASTM C1017, Type I.

H. Epoxy Bonding Agent:

1. Epoxy bonding agent shall conform to ASTM C881 Type I, II, IV or V; Grade 2 for epoxy resin adhesives. The class of epoxy bonding agent shall be suitable for ambient and substrate temperatures.

I. Latex Bonding Compound:

1. Latex bonding compound agents for bonding fresh to hardened concrete shall conform to ASTM C1059.

J. Curing Compound:

1. Liquid form, which will form impervious membrane over exposed surface of concrete when applied to fresh concrete by means of spray gun. Use Type I-D compound with red fugitive dye, Class B, having 18 percent minimum solids conforming to ASTM C309.

K. Burlap Mats:

1. Shall conform to AASHTO M182.

L. Sisal-Kraft Paper and Polyethylene Sheets for Curing:

1. Shall conform to ASTM C171.

2.02 CONCRETE MIXTURES

- A. Supply concrete to meet the project performance requirements. Prepare concrete mix designs in accordance with the specified performance requirements.
- B. Utilize the same mix proportions throughout the Project.
- C. Where the performance of a mix deteriorates to values below the Contract requirements, cease supply of that mix. Re-evaluate the mix, propose revised proportions to meet the performance requirements for the mix, submit trial mix results, and, after the review and accelerated testing, as required by the Construction Manager, utilize the revised mix.
- D. Conform to ASTM C94, except as modified by these specifications.
- E. Air content as determined by ASTM C231:

1. 5 +/- 1-1/2 percent for concrete using 1-1/2 inch maximum aggregate size.
 2. 6 +/- 1-1/2 percent for concrete using 3/4-inch maximum aggregate size.
 3. 5-1/2 +/- 1-1/2 percent for all other concrete.
- F. Provide concrete with the following compressive strengths at 28 days and proportion it for strength and quality requirements in accordance with ACI 318. The resulting mix shall not conflict with limiting values specified in Table 033000-1.

Table 033000-1				
Class	Type of Work	28-Day Minimum Compressive Strength (psi)	Minimum Cementitious Content (lbs. per C.Y.)	Maximum Water/ Cement Ratio
A	Concrete for all structures and concrete not otherwise specified. (Base slabs, stem walls, gate pilasters, etc.)	4,000	560	0.50
B	Pavement, concrete topping	3,000	500	0.54
C	Concrete fill below structure foundations, miscellaneous unreinforced concrete.	2,000	376	0.60
D	Prestressed concrete	6,000	710	0.40
E	Precast concrete	5,000	630	0.40

- G. Measure slump in accordance with ASTM C143:
1. Proportion and produce the concrete to have a slump of 1 to 4 inches. Where placement by pump is approved, the slump shall range from 3 to 6 inches.
 2. Mixes containing water reducers shall have a maximum slump of 6 inches after the addition of a mid-range water reducer and maximum slump of 8 inches after the addition of a high range water reducer.
 3. ASTM C494 Type A or Type F shall be used to produce concrete with sufficient workability for placement without segregation. No excessive bleeding shall be permitted.
- H. Pozzolan Content:

1. Fly ash shall range from 15 to 35 percent by weight of the total cementitious materials.
2. Ground Granulated Blast Furnace Slag (GGBF) will be permitted as a substitute for fly ash at no additional cost to the DEP, in the event that Class F Fly Ash is not available. The slag substitution shall be in the same proportions and percentages of the total cementitious material as shown for fly ash. A higher percentage of GGBF will be allowed if permitted by the Architect/Engineer to suit project needs.

I. Aggregate Size:

1. Nominal maximum-size coarse aggregate shall be 1-1/2 inches or 1 inch, except 3/4-inch nominal maximum-size coarse aggregate shall be used when any of the following conditions exist: the narrowest dimension between sides of forms is less than 7-1/2 inches; the depth of the slab is less than 4 inches; the minimum clear spacing between reinforcing and sheet piling is less than 2-1/4 inches; or the minimum clear spacing between reinforcing is less than 2-1/4 inches.
2. Combined aggregate grading shall be as shown in the following table:

Table 033000-2						
Sieve Sizes	Maximum Aggregate Size					
	1 1/2 inch		1 inch		3/4 inch	
	Percent Passing					
2 inches	100		---		---	
1 1/2 inch	90	to 100	100		---	
1 inch	50	to 86	90	to 100	100	
3/4-inch	45	to 75	55	to 100	90	to 100
3/8-inch	38	to 55	45	to 75	60	to 80
No. 4	30	to 45	35	to 60	40	to 60
No. 8	23	to 38	27	to 45	30	to 45
No. 16	17	to 33	20	to 35	20	to 35
No. 30	10	to 22	12	to 25	13	to 23
No. 50	4	to 10	5	to 15	5	to 15
No. 100	1	to 3	1	to 5	0	to 5
No. 200	0	to 2	0	to 2	0	to 2

PART 3 - EXECUTION

3.01 STANDARDS OF WORKMANSHIP

- A. Cracking of concrete in the structure is generally considered to be detrimental to the long-term performance of the structure. Therefore, all cracks resulting in any visible leakage must be repaired using approved methods and must be repaired by the Contractor at no cost to the DEP.

3.02 INSPECTION

- A. Examine the subgrade and the conditions under which work is to be performed and notify the Construction Manager in writing of unsatisfactory conditions. Do not proceed with the work until unsatisfactory conditions are corrected to comply with specified subgrade conditions in a manner acceptable to the Construction Manager.
- B. The individuals who perform the inspection of concrete construction shall have demonstrated a knowledge and ability equivalent to the ACI minimum guidelines for certification of Concrete Construction Inspector or Concrete Transportation Construction Inspector.

3.03 MIXING AND TRANSPORTING CONCRETE

- A. General: Conform to concreting procedures set forth in ASTM C94 and ACI 304R and as specified herein.
 - 1. Transport concrete to discharge locations without altering the specified properties of water-cement ratio, slump, air entrainment, temperature, and homogeneity.
 - 2. Methods and equipment for conveying and depositing the concrete into the form shall be subject to approval by the Construction Manager. The capacity of the transporting system shall be sufficient to supply concrete at a rate to prevent cold joints from forming during placement. If concrete is to be placed through installed horizontal or sloping reinforcing bars, the concrete shall discharge into a pipe or elephant trunk that is long enough to extend through the reinforcing bars to within 5 feet of the placing surface.
 - 3. Truck mixers operating at agitating speed or truck agitators used for transporting plant-mixed concrete shall conform to the requirements of ASTM C94/C94M. Non-agitating equipment may be used for transporting plant-mixed concrete over a smooth road when the hauling time is less than 15 minutes, unless an approved retarder is used. Bodies of non-agitating equipment shall be smooth, watertight, metal containers specifically designed to transport concrete, shaped with rounded corners to minimize segregation, and equipped with gates that will permit positive control of the discharge of the concrete.

4. Discharge concrete into forms within 1-1/2 hours after cement has entered mixing drum or before the drum has revolved 300 revolutions after the addition of water, whichever occurs first.
5. Do not add water at the jobsite unless permitted by the Architect/Engineer. If it is necessary to add water to obtain the specified slump, add water per ASTM C94, but do not exceed the maximum water content in the reviewed concrete design mix. Added water shall be incorporated by additional mixing of at least 35 revolutions.
6. Do not add water to concrete containing high range water reducing admixture. Do not add water to concrete in delivery equipment not acceptable for mixing.
7. Keep a record showing time and place of each pour of concrete, together with transit-mix delivery slips certifying the contents of the pour.
8. Discharge of concrete shall be completed within the limits set out in Table 033000-3.

Table 033000-3	
Maximum Time to Concrete Discharge	
Concrete Temperature	Limit
Over 90 Degree F	Remove concrete from jobsite and discard concrete
86 to 90 Degree F	45 minutes
81 to 85 Degree F	60 minutes
70 to 80 Degree F	75 minutes
Below 70 Degree F	90 minutes

- B. Conveying: Convey concrete from agitator or mixer truck to place of final deposit in forms by one of the following methods:
1. Buckets or hoppers with discharge gates having a clear opening equal to not less than one-third the maximum interior horizontal area or five (5) times the maximum aggregate size being used, whichever is greater, and side slopes of not less than 60 degrees to horizontal.
 2. Buggies or wheelbarrows equipped with pneumatic tires.
 3. Round bottom, metal or metal-lined chutes with inclined slope of between 2 to 3 feet horizontally to 1 foot vertically and of sufficient capacity to avoid overflow.
 4. Circular drop pipes with a top diameter of at least eight (8) times the maximum aggregate size, but not less than 6 inch, or tapered to not less than six (6) times maximum aggregate size.

5. Concrete may be conveyed by positive displacement pump when approved. The pumping equipment shall be piston or squeeze pressure. The pipeline shall be rigid steel pipe or heavy-duty flexible hose. The inside diameter of the pipe shall be at least three (3) times the nominal maximum-size coarse aggregate in the concrete mixture to be pumped but not less than 4 inches. Aluminum pipe shall not be used.

3.04 CONCRETE ACCEPTANCE

- A. Accept or reject each batch of concrete delivered to the point of agitator or mixer truck discharge. Sign delivery batch tickets to indicate concrete acceptance.
- B. Reject concrete delivered without a complete concrete delivery batch ticket as specified herein. The concrete supplier will furnish copies of the signed batch ticket to the Contractor and Construction Manager.
- C. The testing agency shall perform field tests at the point of agitator or mixer truck discharge. Accept or reject concrete on the basis of conformity with slump, air content, and temperature specified.
- D. The testing agency shall inspect concrete transit truck's barrel revolution counter and gauge for measuring water added to the concrete. Reject concrete that exceeds the maximum barrel revolution of 300, the limits in Table 033000-3, or concrete that has water content exceeding the specified water-cement ratio.
- E. Reject concrete not conforming to specification before discharging into the forms.

3.05 PREPARATION AND COORDINATION

- A. Preconstruction Concrete Meeting:
 1. Prior to concrete construction, hold a meeting to discuss all design requirements and any potential production or construction issues to avoid delays during the implementation of the works.
 2. Have representatives of every party involved in the concrete work attend the meeting, including, but not limited to, the following:
 - a. Contractor's superintendent.
 - b. Concrete subcontractor's Foreman and Cement Finisher.
 - c. Ready-mix concrete producer.
 - d. Admixture manufacturer(s).
 - e. Laboratory responsible for the concrete design mixes and trial mixes.

- f. Concrete pumping subcontractor, if applicable.
 3. The Construction Manager and the Independent Laboratory responsible for field quality control will also attend the meeting. Coordinate with the Construction Manager to establish a date for the meeting at least 10 days prior to the proposed date and at least 35 days prior to the first scheduled concrete placement.
 4. Provide a description of the intended procedures and Quality Assurance for:
 - a. Concrete mix production, delivery, and discharge.
 - b. Concrete mix testing including storage facilities provided by the Contractor and procedures.
 - c. Formwork construction and alignment.
 - d. Installation of Formliners.
 - e. Concrete handling, pumping, and placement.
 - f. Concrete finishing.
 - g. Curing procedures.
 - h. Concrete protection in warm, cold, or windy weather.
 5. Ensure that each party's interests are discussed, and procedures refined to provide optimum concreting practices for this Project.
 6. Distribute minutes of the meeting to all parties present and with related individuals within five (5) days of the meeting.
 7. Ensure that procedures established and agreed at this meeting are carried out during construction.
 8. If additional procedures are required, meet again, discuss, develop, submit, and follow the revised procedures.
- B. Two (2) weeks (14 calendar days) prior to placing of concrete, obtain Construction Manager's approval of the proposed method for the protection of the concrete during placing and curing in adverse weather.
- C. Submit the proposed sequence of casting for review by the Construction Manager, including the location of the proposed construction joints.
- D. Provide three (3) working days' notice, including scheduled start time, prior to concrete placement. The Contractor will be responsible for the testing companies' standby time

costs in the event a concrete pour does not commence within 90 minutes of the proposed time indicated in the three (3) days' notice.

- E. Obtain the Construction Manager's approval before placing concrete.
- F. Coordinate with the concrete supplier with respect to the workability requirements for the concrete. Do not add water to the concrete after the initial batching unless approved by the Architect/Engineer, and the concrete supplier. If approval is granted, a record of the amount of water added must be kept and a copy submitted to the Architect/Engineer within three (3) days for their records.
- G. Establish and maintain accurate records of poured concrete items to indicate date, location and size of pour, temperature of the air, the concrete being placed, the previously placed concrete, the batch ticket number, and the test samples taken.
- H. Laitance must be mechanically removed from the face of concrete from previous castings at construction joints and the surface must be thoroughly cleaned before adjacent concrete is placed.
- I. Hardened concrete paste and rust shall be cleaned from the surface of the reinforcement projecting from the face of the concrete before adjacent concrete is placed.
- J. Sleeves, Inserts, and Embedded Items:
 - 1. Before placement of concrete, care shall be taken to determine that all embedded items are firmly and securely fastened in place as indicated on the Contract Drawings or required. Embedded items shall be free of oil and other foreign matter such as loose coatings or rust, paint, and scale. The embedding of wood in concrete will be permitted only when specifically authorized or directed. Voids in sleeves, inserts, and anchor slots shall be filled temporarily with readily removable materials to prevent the entry of concrete into voids. Welding, including tack welding, will not be permitted on embedded metals within 2 feet of the surface of the concrete.
 - 2. No sleeves, ducts, pipes, or other openings shall pass through joists, beams, column capitals, or columns, except where indicated or approved by the Architect/Engineer.
 - 3. Where approved by the Construction Manager, set sleeves, ties, and other inserts and openings as indicated or specified elsewhere. Sleeves and openings, greater than 4 inches by 4 inches, that are not indicated, must be approved by the Architect/Engineer.
 - 4. Do not eliminate or displace reinforcement to accommodate hardware. If inserts cannot be located as specified, obtain approval of modifications from the Architect/Engineer before placing of concrete.

5. Check locations and sizes of sleeves and openings shown on Drawings.

K. Anchor Bolts:

1. Set anchor bolts to templates under supervision of appropriate trade prior to placing concrete.
2. Under special circumstances, with approval of the Architect/Engineer, grouted anchor bolts may be installed into preformed holes or holes drilled after concrete has set. Formed holes or sleeves shall be a minimum 4 inches diameter and be deformed or dovetailed.
3. Protect anchor bolt holes from water accumulations, and snow and ice buildup.
4. When using proprietary anchor systems, set bolts and fill holes with epoxy grout in accordance with the manufacturer's requirements. All proprietary anchors must be approved by the Architect/Engineer.

L. Drainage Holes and Weep Holes:

1. Form the weep holes and drainage holes in accordance with Section 031000. If wood forms are used, remove them after concrete has set.
2. Install the weep hole tubes and drains as indicated.

M. Coordination:

1. Adjust the work to suit final approved shop drawings of the equipment being supplied. Verify all sizes with the trade supplying and installing the equipment. Obtain, utilize, and submit data on relevant sizes to suit any change in equipment. Confirm the adjustments with the Construction Manager.

N. Grouting:

1. Grout under base plates and/or machinery using procedures in accordance with manufacturer's recommendations that result in 100 percent contact over grouted area. Install bleed holes in base plates to ensure full coverage of grout.

- O. Contractor shall notify the Construction Manager of readiness to place concrete in any portion of the work a minimum of five (5) working days prior to concrete placement. Failure to provide this notification will be cause for delay in placing until observations can be completed.

- P. Reinforcement, installation of waterstop, positioning of embedded items, and condition of formwork will be observed by the Construction Manager prior to concrete placement.

- Q. Coordinate the sequence of placement such that construction joints will occur only as designed.
 - R. Schedule sufficient equipment for continuous concrete placing. Provide for backup equipment and procedures to be taken in case of an interruption in placing. Provide backup concrete vibrators at the Project Site. Test concrete vibrators the day before placing concrete.
 - S. Compact the subgrade and/or bedding in accordance with Section 312300. Saturate the subgrade approximately eight (8) hours before placement and sprinkle ahead of the placement of concrete. The surface shall be free of debris, frost, ice, standing water, mud, and any foreign matter before concrete is deposited.
 - T. Where shown on Contract Drawings, intentionally roughen surfaces of set concrete in a manner to expose bonded aggregate uniformly at joints. Concrete surfaces to which additional concrete is to be bonded shall be prepared for receiving the next lift or adjacent concrete by ensuring that the surface is roughened to an amplitude of 1/4 inch by either air-water cutting, sandblasting, high-pressure water jet, or other approved method. Air-water cutting will not be permitted on formed surfaces or surfaces congested with reinforcing steel. Regardless of the method used, the resulting surfaces shall be free from all laitance and inferior concrete so that clean, well-bonded coarse aggregate is exposed uniformly throughout the lift surface. The edges of the coarse aggregate shall not be undercut. The surface shall be washed clean as the last operation prior to placing the next lift. There shall be no standing water on the surface upon which concrete is placed.
 - U. Provide mud slabs to obtain a dry and stable working platform for placement of all concrete to be poured directly on grade slabs.
 - V. When shown on Contract Drawings, install a granular base beneath slabs on ground. Place granular material on a compacted subgrade and compact granular base.
 - W. Where concrete is required to be placed and bonded to existing concrete, coat the contact surfaces with epoxy bonding agent or latex bonding compound. The method of preparation and application of the bonding agent shall conform to the manufacturer's recommendations.
- 3.06 CONCRETE PLACEMENT
- A. Placement shall conform to ACI 304R as modified by these specifications.
 - B. The capacity of the placing system shall be sufficient to supply concrete at a rate which will prevent cold joints in any placement. Concrete shall be worked into the corners and angles of the forms and around all reinforcement and embedded items without permitting the material to segregate. Concrete shall be deposited as close as possible to its final position in the forms, and in so depositing, there shall be no vertical drop greater than five (5) feet, except where suitable equipment is provided to prevent segregation and

where specifically authorized. Depositing of the concrete shall be so regulated that it will be effectively placed and consolidated with a minimum of lateral movement. The amount of concrete deposited shall be such that it can be readily and thoroughly consolidated and shall not exceed 4 cubic yards in one pile.

- C. Alternate sections of concrete walls and slabs may be cast simultaneously. Do not place adjacent sections of walls and slabs until seven (7) days after placement of first placed concrete.
- D. Do not place concrete until free water has been removed or has been diverted by pipes or other means and carried out from the forms, clear of the work. Do not deposit concrete underwater, and do not allow free water to rise on any concrete until the concrete has attained its initial set. Do not permit free or storm water to flow over surfaces of concrete so as to injure the quality or surface finish.
- E. Do not place concrete during inclement weather. Protect concrete placed from inclement weather. Keep sufficient protective covering ready at all times for this purpose. Place protective tenting over concrete pour and keep rainwater, sleet and snow away from installed concrete.
- F. Deposit concrete at or near its final position to avoid segregation caused by rehandling or flowing. Do not deposit concrete in large quantities in one place to be worked along the forms with a vibrator.
- G. Deposit and consolidate concrete in a continuous operation and in level layers within limits of construction joints, until placement of a section is complete.
 - 1. Consolidate concrete during placement operations so concrete is thoroughly worked around reinforcement and other embedded items and into corners.
 - 2. Maintain reinforcement in position on chairs during concrete placement.
 - 3. Prevent displacement of waterstops during concrete placement.
 - 4. Screed slab surfaces with a straightedge and strike off to correct elevations.
 - 5. Slope surfaces uniformly to drains where required.
 - 6. Begin initial floating using bull floats or darbies to form a uniform and open-textured surface plane, before excess bleed water appears on the surface. Do not further disturb slab surfaces before starting finishing operations.
- H. Avoid inclined layers and cold joints. Place concrete at lower portion of slope first on sloping surfaces.

- I. Do not deposit partially hardened concrete in forms. Retempering of partially hardened concrete is not permitted. Remove partially hardened concrete from site at no additional compensation.
- J. Do not allow concrete to fall freely in forms to cause segregation (separation of coarse aggregate from mortar). Limit maximum free fall of concrete to 4 feet. Do not move concrete horizontally more than 4 feet from point of discharge. Space points of deposit not more than 8 feet apart.
- K. Consolidate concrete using mechanical vibrators operated within the mass of concrete and/or on the forms conforming to procedures set forth in ACI 309R and as specified herein.
- L. Conduct vibration to produce concrete of uniform texture and appearance, free of honeycombing, streaking, cold joints, or visible lift lines.
- M. The use of mechanical vibrators is required. Vibrators of the proper size, frequency, and amplitude shall be used for the type of work being performed in conformance with the following requirements:

Application	Head Diameter Inches	Frequency VPM	Amplitude Inches
Thin walls, beams, etc.	1-1/4 to 2-1/2	9,000 to 13,500	0.02 to 0.04
General construction	2 to 3-1/2	8,000 to 12,000	0.025 to 0.05

The frequency and amplitude shall be determined in accordance with COE CRD-C 521.

- N. A sufficient number of vibrators shall be employed so complete compaction is ensured.
- O. At least one (1) extra gasoline powered vibrator shall be on hand for emergency use.
- P. Vibration shall not be continued to the extent that water forms on the surface.
- Q. Avoid any disturbance to concrete that has become too stiff to regain plasticity when vibrated.
- R. Vibration shall not be applied directly to steel which extends into partially hardened concrete.
- S. Vibration is intended as a method to consolidate the concrete and is to be used for that purpose. Therefore, all slabs and walls must be adequately vibrated to consolidate the concrete around the reinforcement, built-in hardware, openings, and waterstops.
- T. Conduct vibration in a systematic manner with regularly maintained vibrators. Furnish sufficient backup units at job site. Use vibrators having minimum frequency of 8,000

vibrations per minute and of sufficient amplitude to consolidate concrete. Use not less than one (1) vibrator with crew for each 35 to 40 cubic yards of concrete placed per hour.

- U. Insert and withdraw vibrator vertically at a uniform spacing over the entire area of placement. Space distances between insertions such that spheres of influence of each insertion overlap.

- V. Use additional vibration with pencil vibrators on vertical surfaces and on exposed concrete to bring full surface of mortar against the forms so as to eliminate air voids, bug holes, and other surface defects. Employ the following additional procedures for vibrating concrete as necessary to maintain proper consolidation of concrete:
 - 1. Reduce distance between internal vibration insertions and increase time for each insertion.
 - 2. Insert vibrator as close to face of form as possible without contacting form or reinforcement.
 - 3. Thoroughly vibrate area immediately adjacent to waterstops without damaging the waterstop.
 - 4. Use spading as a supplement to vibration where particularly difficult conditions exist.

- W. Pumping Concrete:
 - 1. Conform to the recommendations of ACI 304.2R except as modified herein.
 - 2. Base pump size on rate of concrete placement, length of delivery pipe or hose, aggregate size, mix proportions, vertical lift, and slump of concrete.
 - 3. Use pipe with inside diameter of at least three (3) times the maximum coarse aggregate size, but not less than 2 inches.
 - 4. Do not use aluminum pipes for delivery of concrete to the forms.
 - 5. When concrete is to be placed by pump, the nominal maximum-size coarse aggregate shall not be reduced to accommodate the pumps. The distance to be pumped shall not exceed limits recommended by the pump manufacturer. The concrete shall be supplied to the concrete pump continuously. When pumping is completed, concrete remaining in the pipeline shall be ejected without contamination of concrete in place. After each operation, equipment shall be thoroughly cleaned, and flushing water shall be wasted outside of the forms. Grout used to lubricate the pumping equipment at the beginning of the placement shall not be incorporated into the placement.

3.07 CURING AND PROTECTION

A. General:

1. Immediately after placement, concrete shall be protected from premature drying, extremes in temperature, rapid temperature change, and mechanical damage. All materials and equipment needed for adequate curing and protection shall be available and at the placement site prior to the start of concrete placement. Concrete shall be protected from the damaging effects of rain for 12 hours and from flowing water for 14 days or seven (7) days with Type III cement. No fire or excessive heat, including welding, shall be permitted near or in direct contact with concrete or concrete embedment at any time.
2. Comply with curing procedures set forth in ACI 301, ACI 308, and as specified herein.
3. Perform hot weather concreting in conformance with ACI 305R and as specified herein when the ambient atmospheric temperature is 80 degrees F or above.
4. Perform cold weather concreting in conformance with ACI 306R, except as specified herein.
5. Concrete required to be moist cured shall remain moist for the entire duration of the cure. Repeated wetting and drying cycles of the curing process will not be allowed.

B. Curing Duration:

1. Start curing after placing and finishing concrete as soon as free moisture has disappeared from unformed concrete surfaces. Initial curing starts as soon as concrete achieves final set. Forms left tightly in place are considered as part of the curing system, provided that wooden forms are kept continuously moist. Continue final curing for at least 14 days and in accordance with ACI 301 procedures.
2. Avoid rapid drying at the end of the final curing period.

C. Curing Requirements:

1. **Moist Curing:** Moist-cured concrete shall be maintained continuously, not periodically, wet for the entire curing period. Vertical surfaces shall be cured using soaker hoses, fog sprayers, or sprinklers. Burlap may be used to assist moist curing provided that the wall and burlap are kept continuously saturated, including nights and weekends, and the burlap is kept in contact with the concrete being cured. If water or curing materials stain or discolor concrete surfaces that are to be permanently exposed, they shall be cleaned as required in Paragraph 1.08 "Appearance." Where wooden form sheathing is left in place during curing, the

sheathing shall always be kept wet. Where steel forms are left in place during curing, the forms shall be carefully broken loose from the hardened concrete and curing water continuously applied into the void so as to continuously saturate the entire concrete surface. Horizontal surfaces may be moist cured by ponding, by covering with a minimum uniform thickness of 2 inches of continuously saturated sand, or by covering with saturated non-staining burlap or cotton mats. Horizontal construction joints may be allowed to dry for 12 hours immediately prior to the placing of the following lift.

2. Membrane-Forming Curing Compound: Concrete may be cured with an approved membrane-forming curing compound in lieu of moist curing except that membrane curing will not be permitted on any surface to which a grout cleaned finish is to be applied or a cementitious paint finish is to be applied or other concrete is to be bonded, on any surface containing protruding steel reinforcement, on an abrasive aggregate finish, or any surface maintained at curing temperature by use of free steam. A pigmented-type curing compound shall not be used on surfaces that will be exposed to view when the project is complete. Concrete cured with non-pigmented curing compound must be shaded from the sun for the first three (3) days when the ambient temperature is 90 degrees F or higher.

- a. Application: The curing compound shall be applied to formed surfaces immediately after the forms are removed and prior to any patching or other surface treatment except the cleaning of loose sand, mortar, and debris from the surface. The surfaces shall be thoroughly moistened with water, and the curing compound applied as soon as free water disappears. The curing compound shall be applied to unformed surfaces as soon as free water has disappeared and bleeding has stopped. The curing compound shall be applied in a two-coat continuous operation by approved motorized power-spraying equipment operating at a minimum pressure of 75 psi, at a uniform coverage of not more than 400 square feet per gallon for each coat, and the second coat shall be applied perpendicular to the first coat. Concrete surfaces that have been subjected to rainfall within three (3) hours after curing compound has been applied shall be resprayed by the method and at the coverage specified. All concrete surfaces on which the curing compound has been applied shall be adequately protected for the duration of the entire curing period from pedestrian and vehicular traffic and from any other cause that will disrupt the continuity of the curing membrane.

- D. Protection from environmental conditions: Maintain the concrete temperature above 50 degrees F continuously throughout the curing period. Make arrangements before concrete placing for heating, covering, insulation, or housing to maintain the specified temperature and moisture conditions continuously for the curing period.

1. When the atmospheric temperature is 80 degrees F and above, or during other climatic conditions which will cause too rapid drying of the concrete, make

arrangements before the start of concrete placing for the installation of wind breaks or shading, and for fog spraying, wet sprinkling, or moisture-retaining covering.

2. Protect the concrete continuously for the entire curing period.
 3. Maintain concrete temperature as uniformly as possible and protect from rapid atmospheric temperature changes.
 4. Avoid temperature changes in concrete that exceed 5 degrees F in anyone (1) hour period and 50 degrees F in any 24-hour period.
- E. Protection from physical injury: Protect concrete from physical disturbances such as shock and vibration during curing period. Protect finished concrete surfaces from damage by construction equipment, materials, curing procedures, and rain or running water. Do not load concrete in such a manner as to overstress concrete.
- F. Protection from Deicing Agents: Do not apply deicing chemicals to concrete.

3.08 FIELD QUALITY CONTROL

A. Hot Weather Requirements

1. During hot weather, give proper attention to ingredients, production methods, handling, placing, protection, and curing to prevent excessive concrete temperatures or water evaporation in accordance with ACI 305R and the following.
2. When the weather is such that the temperature of the concrete as placed would exceed 90 degrees F, use ice or other means of cooling the concrete during mixing and transportation so that the temperature of the concrete as placed will not exceed 90 degrees F.
3. Maintain concrete temperature below 85 deg F at time of placement when measured in accordance with ASTM C1064. Chilled mixing water or chopped ice may be used to control temperature, provided water equivalent of ice is calculated to total amount of mixing water. Using liquid nitrogen to cool concrete is Contractor's option.
4. Fog-spray forms, steel reinforcement, and subgrade just before placing concrete. Keep subgrade uniformly moist without standing water, soft spots, or dry areas.
5. Conveying and placing equipment shall be cooled, if necessary, to assist in maintaining the specified concrete placing temperature.
6. Take precautions when placing concrete during hot, dry weather to eliminate early setting of concrete. This includes protection of reinforcing from direct sunlight to

prevent heating of reinforcing, placing concrete during cooler hours of the day, and the proper and timely application of specified curing methods.

7. There will be no additional reimbursement to the Contractor for costs incurred for placing concrete in hot weather.

B. Cold Weather Requirements

1. Provide adequate equipment for heating concrete materials and protecting concrete during freezing or near-freezing weather in accordance with ACI 306R and the following.
2. When the temperature of the surrounding atmosphere is 40 degrees F or is likely to fall below this temperature, use heated mixing water not to exceed 140 degrees F. Do not allow the heated water to come in contact with the cement before the cement is added to the batch.
3. When placed in the forms during cold weather, maintain concrete temperature at not less than 55 degrees F for concrete elements less than 12 inches thick and not less than 50 degrees F for concrete elements greater than 12 inches thick when measured in accordance with ASTM C1064. Materials shall be free from ice, snow, and frozen lumps before entering the mixer.
4. Salt, chemicals, or other materials shall not be mixed with the concrete to prevent freezing.
5. Maintain the air and the forms in contact with the concrete at temperatures above 40 degrees F for the first five (5) days after placing, and above 35 degrees F for the remainder of the curing period. Provide thermometers to indicate the ambient temperature and the temperature 2 inches inside the concrete surface.
6. There will be no additional reimbursement made to the Contractor for costs incurred for placing concrete during cold weather.

C. Backfill Against Walls

1. Do not place backfill against walls until the concrete has obtained a compressive strength equal to the specified 28-day compressive strength. Where backfill is to be placed on both sides of the wall, place the backfill uniformly on both sides.
2. Do not backfill the walls of structures that will be laterally restrained or supported by suspended slabs or slabs on grade until the slab is poured and the concrete has reached the specified compressive strength.

D. Concrete Testing

1. Concrete quality testing will be performed on the concrete by independent testing agency retained by the Contractor.
2. The testing agency will use concrete samples provided by the Contractor at the point of agitator or mixer truck discharge to perform slump (per ASTM C143), air content (per ASTM C231), and temperature tests (per ASTM C1064) and for field control test specimens.
3. The testing agency will submit test reports of concrete field measurements specified above to the Construction Manager at the end of each day of placement.
4. Provide and maintain facilities for safe storage and proper curing of concrete test specimens on the project site, as required by ASTM C31.
5. Concrete Quality Test Specimen:
 - a. Perform sampling and curing of test specimen in accordance with ASTM C31.
 - b. Testing agency personnel will record truck and load number from the delivery batch ticket, the concrete placement location of each specimen, the date, concrete strength, slump, air content, and temperature.
 - c. The testing agency will cast a minimum of one (1) set of six (6) test specimens, each 6-inch diameter by 12-inch-long cylinders, for each one hundred fifty (150) cubic yards of each mix design of concrete placed but not less than once a day.
 - d. Test cylinders in accordance with ASTM C39. Test one (1) cylinder at seven (7) days and one (1) cylinder at fourteen (14) days for information; test two (2) cylinders at 28 days for acceptance; and hold two (2) reserve cylinders for verification This process shall be applied to each class or formulation of concrete used on the project. Strength acceptance will be based on the average of the strengths of the two (2) cylinders tested at 28 days. If one (1) cylinder of a 28-day test manifests evidence of improper sampling, molding, or testing, other than low strength, discard it and use a reserve cylinder for the test result.
6. The Contractor may take field control test specimens for small quantities of concrete.
7. Concrete acceptance shall be based on the requirements of ACI 318.
8. Field cured cylinders conforming to ASTM C31 will be required to determine field compressive strength of concrete. Laboratory cured cylinders for concrete quality testing shall not be used for determining field compressive strength.

9. Concrete Coring:

- a. When the concrete quality test specimen compression tests fail to be in compliance with the Contract Documents or when the Construction Manager detects deficiencies in the concrete, the Contractor will take concrete cores at least 2 inches in diameter from the structure in conformance with ASTM C 42 at locations determined by the Construction Manager.
- b. Obtain at least three (3) representative cores from each member or area of concrete that is considered potentially deficient.
- c. Obtain additional cores to replace cores that show evidence of having been damaged subsequent to or during removal from the structure.
- d. The testing agency shall compression test the cores taken from the structure in conformance with ASTM C39 and submit test strength test results of cores specified above to the Contractor and to the Construction Manager.
- e. All costs associated with coring and testing of cores will be borne by the Contractor at no additional cost to the DEP.

3.09 EXAMINATION OF COMPLETED STRUCTURES

- A. Undertake, with the Construction Manager, review of concrete surfaces for defects and finishes.
- B. Undertake, with the Construction Manager, assessments, and measurements of the concrete structures for cracking.
- C. Provide a written summary of defects noted complete with a plan showing location of each defect.
- D. Submit a plan for repair of each defect in accordance with the Contract Sections.

3.10 PATCHING OR REPAIRS

- A. No patching or repairing shall be carried out without the approval of the Construction Manager.
- B. All honeycombing shall be chipped out to sound concrete. The edge around the perimeter of the area shall be sawcut to a depth of 1 inch minimum to eliminate all “feather” edges. All mortar, used to repair honeycombing, shall be a proprietary repair material. If honeycombing extends to the depth of the reinforcement, the concrete removal shall be continued to a depth of 1.4 times the diameter of the largest reinforcing bar or 1-1/2 inches minimum beyond the layer of reinforcement, whichever is greater.

- C. The patch shall be continuously covered with a 6-mil polyethylene sheet and heated to above 60 degrees F for 14 days.
- D. Chips and edge breaks in the concrete shall be repaired as noted above.
- E. Perform structural repairs of concrete, subject to Construction Manager's approval, using epoxy adhesive and patching mortar.

3.11 FINISHES

- A. The ambient temperature of spaces adjacent to surfaces being finished shall be not less than 40 degrees F. In hot weather when the rate of evaporation of surface moisture, as determined by use of Figure 2.1.5 of ACI 305R, may reasonably be expected to exceed 0.2 pounds per square foot per hour, provisions for windbreaks, shading, fog spraying, or wet covering with a light-colored material shall be made in advance of placement, and such protective measures shall be taken as quickly as finishing operations will allow. All unformed surfaces that are not to be covered by additional concrete or backfill shall have a float finish. Additional finishing shall be as specified below and shall be true to the elevation shown in the drawings. Surfaces to receive additional concrete or backfill shall be brought to the elevation shown on the drawings and left true and regular. Exterior surfaces shall be sloped for drainage unless otherwise shown in the drawing or as directed. Joints shall be carefully made with a jointing or edging tool. The finished surfaces shall be protected from stains or abrasions. Grate tampers or jitterbugs shall not be used.
- B. Unformed Surfaces
 - 1. Float Finish: Surfaces shall be screeded and darbied, or bullfloated, to bring the surface to the required finish level with no coarse aggregate visible. No water, cement, or mortar shall be added to the surface during the finishing operation. The concrete, while still green but sufficiently hardened to bear a man's weight without more than about a 1/4-inch indentation, shall be floated to a true and even plane. Floating may be performed by use of suitable hand floats or power-driven equipment. Hand floats shall be made of magnesium or aluminum.
 - 2. Trowel Finish: A trowel finish shall be applied to the top surfaces of walls and base slabs. Concrete surfaces shall be finished with a float finish, and after surface moisture has disappeared, the surface shall be troweled to a smooth, even, dense finish free from blemishes including trowel marks.
 - 3. Broom Finish: A broom finish shall be applied to the following surfaces: all gate structure roadways, sidewalks, slope paving. The concrete surface shall be finished with a float finish. The floated surface shall be broomed with a fiber-bristle brush in a direction transverse to that of the main traffic.
- C. Formed Surfaces

1. Unless another finish is specified, surfaces shall be left with the texture imparted by the forms except that defective surfaces shall be repaired as described in paragraph 3.11.C.5 "Formed Surface Repair." Other finishes shall be applied to the following structures or portions of structures:

TYPES OF FINISH	STRUCTURE OR PORTION OF STRUCTURE
Texture	Exterior side and interior side surfaces of walls.

2. Unless painting of surfaces is required, uniform color of the concrete shall be maintained by use of only one mixture without changes in materials or proportions for any structure or portion of structure that is exposed to view or on which a special finish is required. The form panels used to produce the finish shall be orderly in arrangement, with joints between panels planned in approved relation to openings, corners, and other architectural features. Forms shall not be reused if there is any evidence of surface wear or defects that would impair the quality of the surface.
3. Grout-Cleaned Finish: The surfaces of exterior side and interior side of walls without textured finish and gate pilasters shall be given a grout-cleaned finish as described, as approved by the Architect/Engineer and after all required curing, cleaning, and repairs have been completed. Surfaces to be grout-cleaned shall be moist cured for the required period of time before application of the grout-cleaned finish. Grout-cleaning shall be delayed until near the end of construction on all surfaces not to be painted in order to achieve uniformity of appearance and reduce the chance of discoloring caused by subsequent construction operations. The temperature of the air adjacent to the surface shall be not less than 40 degrees F for 24 hours prior to and 72 hours following the application of the finish. The finish for any area shall be completed in the same day, and the limits of a finished area shall be made at natural breaks in the finished surface. The surface to receive grout-cleaned finish shall be thoroughly wetted to prevent absorption of water from the grout but shall have no free water present. The surface shall then be coated with grout. The grout shall be applied as soon as the surface of the concrete approaches surface dryness and shall be vigorously and thoroughly rubbed over the area with clean burlap pads, cork floats or stones, so as to fill all voids. The grout shall be composed of one (1) part portland cement as used on the project, to two (2) parts by volume of well-graded sand passing a No. 30 sieve mixed with water to the consistency of thick paint. White portland cement shall be used for all or part of the cement as approved by the Construction Manager to give the desired finish color. The applied coating shall be uniform, completely filling all pits, air bubbles, and surface voids. While the grout is still plastic, remove all excess grout by working the surface with a rubber float, burlap pad, or other means. Then, after the surface whitens from drying (about 30 minutes at normal temperature) rub vigorously with clean burlap pads. Immediately after rubbing is completed, the finished surface shall be continuously moist cured for 72 hours. Burlap pads used

for this operation shall be burlap stretched tightly around a board to prevent dishing the mortar in the voids.

4. Textured Finish: This type of finish shall be applied where specified to conform to details shown in the drawings by use of approved textured form liners. Liner panels shall be secured in the forms by methods recommended by the manufacturer but not by methods that will permit impressions of nail heads, screw heads, washers, or the like to be imparted to the surface of the concrete. Edges of textured panels shall be sealed to each other to prevent grout leakage. The sealant used shall be non-staining to the surface. The finish shall be similar to and shall closely match the finish on the sample panel.
5. Formed Surface Repair: After removal of forms, all ridges, lips, and bulges on surfaces permanently exposed shall be removed. All repairs shall be completed within 48 hours after form removal.
6. Classes A Finishes: Surfaces listed in Section 031000 and as shown to have classes A finishes shall have surface defects repaired as follows: defective areas, voids, and honeycombs smaller than 16 square inches in area and less than 1/2 inch deep and bug holes exceeding 1/2 inch in diameter shall be chipped and filled with dry-packed mortar. Holes left by removal of tie rods shall be reamed and filled with dry-packed mortar as specified in paragraph "Material and Procedure for Repairs." Defective and unsound concrete areas larger than described shall be defined by 1/2-inch deep dovetailed saw cuts in a rectangular pattern with lines parallel to the formwork, the defective concrete removed by chipping, and the void repaired with replacement concrete. The prepared area shall be brush-coated with a latex bonding agent or a neat cement grout after dampening the area with water. The void shall be filled with replacement concrete in accordance with paragraph 3.11.C.8 "Material and Procedure for Repairs."
7. Class D Finish: Surfaces listed in Section 031000 and as shown to have class D finish shall have surface defects repaired as follows: defective areas, voids, and honeycombs greater than 48 square inches in area or more than 2 inches deep shall be defined by 1/2-inch-deep dovetailed saw cuts in a rectangular pattern, the defective concrete removed by chipping and the void repaired with replacement concrete. The prepared area shall be brush-coated with a latex bonding agent meeting the requirements of paragraph "Latex Bonding Compound," or a neat cement grout after dampening the area with water. The void shall be filled with replacement concrete in accordance with paragraph 3.11.C.8 "Material and Procedure for Repairs."
8. Material and Procedure for Repairs: The cement used in the dry-packed mortar or replacement concrete shall be a blend of the cement used for production of project concrete and white portland cement properly proportioned so that the final color of the mortar or concrete will match adjacent concrete. Trial batches shall be used to

determine the proportions required to match colors. Dry-packed mortar shall consist of one (1) part cement to two and one-half (2.5) parts fine aggregate. The fine aggregate shall be that used for production of project concrete. The mortar shall be remixed over a period of at least 30 minutes without addition of water until it obtains the stiffest consistency that will permit placing. Mortar shall be thoroughly compacted into the prepared void by tamping, rodding, ramming, etc. and struck off to match adjacent concrete. Replacement concrete shall be produced using project materials and shall be proportioned by the Construction Manager. It shall be thoroughly compacted into the prepared void by internal vibration, tamping, rodding, ramming, etc. and shall be struck off and finished to match adjacent concrete. Forms shall be used to confine the concrete. If an expanding agent is used in the repair concrete, the repair shall be thoroughly confined on all sides including the top surface. Metal tools shall not be used to finish permanently exposed surfaces. The repaired areas shall be cured for seven (7) days. The temperature of the in-situ concrete, adjacent air, and replacement mortar or concrete shall be above 40 degrees F during placement, finishing, and curing. Other methods and materials for repair may be used only when approved in writing by the Construction Manager. Repairs of the so called "plaster-type" will not be permitted.

3.12 CONCRETE QUALITY ASSURANCE

- A. Monitor the performance of each concrete mix as Work proceeds. Where performance remains appropriate, maintain the mix proportions, and continue the monitoring. Where performance does not meet the standards set at the outset of the project, or it is unacceptable for any reason, design and test the new mixes to verify that they will improve the performance or correct the deficiencies. Submit the revised mixes and related laboratory test results as soon as possible.

3.13 CONTRACT CLOSEOUT

- A. Provide in accordance with Section 017700.

END OF SECTION 033000

SECTION 033300 - ARCHITECTURAL CONCRETE

PART 1 - GENERAL

1.01 DESCRIPTION

- A. This Section describes materials and methods of concrete, color and finishes for cast-in-place concrete slab on the Cove Park Pedestrian Bridge. The placement of this concrete slab shall be performed in one pour without construction joint or cold joint.

1.02 SUMMARY

- A. Section includes cast-in-place architectural concrete, including reinforcement and accessories, concrete materials, concrete mixture design, placement procedures, color, and finishes.

1.03 PAYMENT

- A. No separate payment shall be made for performing any Work required under this Section. All costs for Work required by this Section shall be included in the applicable Cove Park lump sum, as set forth in Section 012901.

1.04 RELATED DOCUMENTS

- A. General Conditions Article 4.7 – Shop Drawings and Other Submittals.
- B. Section 012901 – Measurement and Payment.
- C. Section 014300 - Quality Requirements.
- D. Section 016100 - Control of Materials.
- E. Section 017700 - Contract Closeout.
- F. Section 032100 – Steel Reinforcement
- G. Section 033000 – Cast-in-Place Concrete

1.05 DEFINITIONS

- A. Cast-in-Place Architectural Concrete: Finished concrete that is exposed to view on surfaces of the bridge floor structure and that requires special concrete materials, formwork, placement, and finishes to obtain specified architectural appearance.

- B. Cementitious Materials: Portland cement alone or in combination with one or more of the following: blended hydraulic cement, fly ash, slag cement, other pozzolans, and silica fume; materials subject to compliance with requirements.
- C. Design Reference Sample: Sample designated by Architect/Engineer in the Contract Documents that reflects acceptable surface quality and appearance of cast-in-place architectural concrete.
- D. Reveal: Projection of coarse aggregate from matrix or mortar after completion of exposure operations.
- E. W/C Ratio: The ratio by weight of water to cementitious materials.

1.06 PREINSTALLATION MEETINGS

- A. Preinstallation Conference: Conduct conference at Project Site.
 - 1. Require representatives of each entity directly concerned with cast-in-place architectural concrete to attend, including the following:
 - a. Contractor's superintendent.
 - b. Independent testing agency responsible for concrete design mixtures.
 - c. Ready-mix concrete manufacturer.
 - d. Cast-in-place architectural concrete Subcontractor.
 - 2. Review concrete finishes and finishing, cold- and hot-weather concreting procedures, curing procedures, construction joints, forms and form-removal limitations, reinforcement accessory installation, concrete repair procedures, and protection of cast-in-place architectural concrete slab.
 - 3. Before submitting design mixtures, review concrete design mixture and examine procedures for ensuring quality of concrete materials.

1.07 SUBMITTALS

- A. Submit the following in accordance with General Conditions Article 4.7.
 - 1. Product Data: For each type of product.
 - 2. Design Mixtures: For each concrete mixture. Submit alternate design mixtures when characteristics of materials, Project conditions, weather, test results, or other circumstances warrant adjustments.
 - a. Indicate amounts of mixing water to be withheld for later addition at Project site.

3. Formwork Shop Drawings: Show formwork construction, including form-facing joints, rustications, construction and contraction joints, form joint-sealant details, form tie locations and patterns, inserts and embedments, cutouts, cleanout panels, and other items that visually affect cast-in-place architectural concrete.
4. Placement Schedule: Submit concrete placement schedule before start of placement operations. Include locations of all joints, including construction joints.
5. Samples: For each of the following materials:
 - a. Exposed aggregates.
 - b. Coarse- and fine-aggregate gradations.
 - c. Chamfers and rustications.
6. Samples for Verification: Architectural concrete Samples, cast horizontally, approximately 18 by 18 by 2 inches of Finishes, Colors, and Textures to match design reference sample. Include Sample sets showing the full range of variations expected in these characteristics.
7. Qualification Data: For manufacturer and testing agency.
8. Material Certificates: For each of the following, signed by manufacturers:
 - a. Cementitious materials.
 - b. Admixtures.
 - c. Form materials and form-release agents.
 - d. Repair materials.
9. Material Test Reports: For the following, by a qualified testing agency:
 - a. Aggregates: Include service-record data indicating absence of deleterious expansion of concrete due to alkali-aggregate reactivity.

1.08 QUALITY ASSURANCE

- A. Manufacturer Qualifications: A firm experienced in manufacturing ready-mixed concrete products and that complies with ASTM C 94/C 94M requirements for production facilities and equipment.
 1. Manufacturer certified according to NRMCA's "NRMCA Quality Control Manual - Section 3, Certification of Ready Mixed Concrete Production Facilities."

- B. Testing: The Contractor shall engage an independent testing agency. Contractor shall provide safe access to the testing agency to obtain material samples.

- C. Field Sample Panels: After approval of verification sample and before casting architectural concrete, produce field sample panels to demonstrate the approved range of selections made under Sample submittals. Produce a minimum of three sets of full-scale panels, cast vertically, approximately 48 by 48 by 6 inches minimum, to demonstrate the expected range of finish, color, and texture variations.
 - 1. Locate panels as indicated or, if not indicated, as directed by Architect/Engineer.
 - 2. Demonstrate methods of topping finishing, curing, aggregate exposure, sealers, and coatings, as applicable.
 - 3. In presence of Architect/Engineer, damage part of an exposed-face surface for each finish, color, and texture, and demonstrate materials and techniques proposed for repair of tie holes and surface blemishes to match adjacent undamaged surfaces.
 - 4. Maintain field sample panels during construction in an undisturbed condition as a standard for judging the completed Work.
 - 5. Demolish and remove field sample panels when directed.

- D. Mockups: Before casting architectural concrete, build mockups to verify selections made under Sample submittals and to demonstrate typical joints, surface color, finish, texture, tolerances, and standard of workmanship. Build mockups to comply with the following requirements, using materials indicated for the completed Work:
 - 1. Build mockups in the location and of the size indicated or, if not indicated, as directed by Architect/Engineer.
 - 2. Build mockups of typical exterior bridge slab of cast-in-place architectural concrete as shown on the Contract Drawings.
 - 3. Demonstrate topping finishing, curing, cleaning, and protecting of cast-in-place architectural concrete, finishes, and contraction joints, as applicable.
 - 4. In presence of Architect/Engineer, damage part of the exposed-face surface for each finish, color, and texture, and demonstrate materials and techniques proposed for repair of tie holes and surface blemishes to match adjacent undamaged surfaces.
 - 5. Obtain Architect/Engineer's approval of mockups before casting architectural concrete.

1.09 PRECONSTRUCTION TESTING

- A. Preconstruction Testing Service: Engage a qualified testing agency to perform preconstruction testing on concrete mixtures.

1.10 FIELD CONDITIONS

- A. Cold-Weather Placement: Comply with ACI 306.1 and as follows. Protect concrete work from physical damage or reduced strength that could be caused by frost, freezing actions, or low temperatures.
 - 1. When average high and low temperature is expected to fall below 40 deg F for three successive days, maintain delivered concrete mixture temperature within the temperature range required by ACI 301.
 - 2. Do not use frozen materials or materials containing ice or snow. Do not place concrete on frozen subgrade or on subgrade containing frozen materials.
 - 3. Do not use calcium chloride, salt, or other materials containing antifreeze agents.
 - 4. Do not use chemical accelerators unless otherwise specified and approved in design mixtures.
- B. Hot-Weather Placement: Comply with ACI 301 and as follows:
 - 1. Maintain concrete temperature below 90 deg F at time of placement. Chilled mixing water or chopped ice may be used to control temperature, provided water equivalent of ice is calculated to total amount of mixing water. Using liquid nitrogen to cool concrete is Contractor's option.
 - 2. Fog-spray forms, steel reinforcement, and subgrade just before placing concrete. Keep subgrade uniformly moist without standing water, soft spots, or dry areas.

PART 2 - PRODUCTS

2.01 CONCRETE, GENERAL

- A. ACI Publications: Comply with the following unless modified by requirements in the Contract Documents:
 - 1. ACI 301.
 - 2. ACI 303.1.

2.02 FORM-FACING MATERIALS

- A. General: Comply with Section 033000 for formwork and other form-facing material requirements.
- B. Source Limitations: Obtain each type form-facing material from single source from single manufacturer.
- C. Form-Facing Panels for As-Cast Finishes: Steel- and glass-fiber-reinforced plastic, or other approved nonabsorptive panel materials that provide continuous, true, and smooth architectural concrete surfaces. Furnish in largest practicable sizes to minimize number of joints.
- D. Forms for Cylindrical Columns, Pedestals, and Supports: Metal, glass-fiber-reinforced plastic, paper, or fiber tubes that provide surfaces with gradual or abrupt irregularities not exceeding specified formwork surface class. Provide units with sufficient wall thickness to resist plastic concrete loads without detrimental deformation.
- E. Pan-Type Forms: Glass-fiber-reinforced plastic or formed steel, stiffened to resist plastic concrete loads without detrimental deformation.
- F. Rustication Strips: Rigid Polyethylene, or with sides beveled and back kerfed; nonstaining; in longest practicable lengths.
- G. Chamfer Strips: Rigid Polyethylene (white slick plastic) or elastomeric rubber, 1/2 by 1/4 inch; nonstaining; milled smooth on all contact drafted surfaces in longest practicable lengths. Contact side surfaces shall not have projections, saw marks or deformities.
- H. Form Joint Sealant: Elastomeric sealant complying with ASTM C 920, Type M or Type S, Grade NS, that adheres to form joint substrates.
- I. Sealer: Penetrating, clear, polyurethane wood form sealer formulated to reduce absorption of bleed water and prevent migration of set-retarding chemicals from wood.
- J. Form-Release Agent: Commercially formulated, colorless form-release agent that will not bond with, stain, or adversely affect architectural concrete surfaces and will not impair subsequent treatments of those surfaces.
 - 1. Formulate form-release agent with rust inhibitor for steel form-facing materials.
- K. Surface Retarder: Chemical liquid set retarder, for application on form-facing materials, capable of temporarily delaying final hardening of newly placed concrete surface to depth of reveal specified.

2.03 STEEL REINFORCEMENT AND ACCESSORIES

- A. Comply with Section 032100 and Section 031500 for steel reinforcement and other requirements for reinforcement accessories.

2.04 CONCRETE MATERIALS

- A. Comply with requirements of Section 033000 except as follows that are specific to the Cove Park architectural structures.
- B. Regional Materials: Concrete shall be manufactured within 500 miles of Project site from aggregates and cementitious materials that have been extracted, harvested, or recovered, as well as manufactured, within 500 miles of Project site.
- C. Source Limitations: Obtain each type or class of cementitious material of the same brand from the same manufacturer's plant, obtain aggregate from single source, and obtain admixtures from single source from single manufacturer.
- D. Cementitious Materials: ASTM C989 or ASTM C618.
 - 1. Portland Cement: ASTM C 150/C 150M, Type I or III, white.
 - 2. Fly Ash: ASTM C 618, Class F, may be used up to maximum of 25 percent of the total cementitious content.
 - 3. Slag Cement: ASTM C 989/C 989M, Grade 100 or Grade 120 may be used up to a maximum of 40 percent of the total cementitious content.
 - 4. Silica Fume: ASTM C 1240 amorphous silica.
 - 5. The exact percentages may require adjustment after test placement on the site and seasonal weather adjustments.
- E. Normal-Weight Aggregates: ASTM C 33/C 33M. Washed, hard, crushed stone coarse aggregate or better, graded. Provide aggregates from single source.
 - 1. Maximum Coarse-Aggregate Size: 3/4 inch shall be 8 percent to 22 percent retained on each sieve below the top size and above the No. 100.
 - 2. Gradation: Uniformly graded.
- F. Normal-Weight Fine Aggregate: ASTM C 33/C 33M. Hard, natural sand, from same source for entire Project.
- G. Air-Entraining Admixture: ASTM C 260/C 260M.

- H. Chemical Admixtures: Certified by manufacturer to be compatible with other admixtures and that does not contribute water-soluble chloride ions exceeding those permitted in hardened concrete. Do not use calcium chloride or admixtures containing calcium chloride.
 - 1. Water-Reducing Admixture: ASTM C 494/C 494M, Type A.
 - 2. Retarding Admixture: ASTM C 494/C 494M, Type B.
 - 3. Water-Reducing and Retarding Admixture: ASTM C 494/C 494M, Type D.
 - 4. High-Range, Water-Reducing Admixture: ASTM C 494/C 494M, Type F.
 - 5. High-Range, Water-Reducing and Retarding Admixture: ASTM C 494/C 494M, Type G.
 - 6. Plasticizing and Retarding Admixture: ASTM C 1017/C 1017M, Type II.
- I. Color Pigment: ASTM C 979/C 979M, synthetic mineral-oxide pigments or colored water-reducing admixtures; color stable, free of carbon black, nonfading, and resistant to lime and other alkalis.
 - 1. Color: Match Architect/Engineer's sample.
- J. Water: Potable, complying with ASTM C 94/C 94M, except free of wash water from mixer washout operations.

2.05 CURING MATERIALS

- A. Absorptive Cover: AASHTO M 182, Class 2, burlap cloth made from jute or kenaf, weighing approximately 9 oz./sq. yd. when dry.
- B. Moisture-Retaining Cover: ASTM C 171, polyethylene film or white burlap-polyethylene sheet.
- C. Waterborne, Membrane-Forming Curing Compound: ASTM C 309, Type 1, Class B.
 - 1. For integrally colored concrete, curing compound shall be approved by color pigment manufacturer.
 - 2. For concrete indicated to be sealed, curing compound shall be compatible with sealer.

2.06 REPAIR MATERIALS

- A. Bonding Agent: ASTM C 1059/C 1059M, Type II, nonredispersible, acrylic emulsion or styrene butadiene.

- B. Epoxy Bonding Adhesive: ASTM C 881/C 881M two-component epoxy resin, capable of humid curing and bonding to damp surfaces, of class suitable for application temperature and of grade to suit requirements.
 - 1. Types IV and V, load bearing, for bonding hardened or freshly mixed concrete to hardened concrete.

2.07 CONCRETE MIXTURES

- A. Obtain each color, size, type, and variety of concrete mixture from single manufacturer with resources to provide cast-in-place architectural concrete of consistent quality in appearance and physical properties.
- B. Prepare design mixtures for each type and strength of cast-in-place architectural concrete proportioned on basis of laboratory trial mixture or field test data, or both, according to ACI 301.
 - 1. Use a qualified independent testing agency for preparing and reporting proposed design mixtures based on laboratory trial mixtures.
- C. Cementitious Materials: For cast-in-place architectural concrete exposed to deicers, limit percentage, by weight, of cementitious materials other than portland cement according to ACI 301 requirements. Use fly ash, pozzolan, slag cement, and silica fume as needed to reduce the total amount of portland cement, which would otherwise be used, by not less than 40 percent.
- D. Limit water-soluble, chloride-ion content in hardened concrete to 0.06 percent by weight of cement.
- E. Admixtures: Use admixtures according to manufacturer's written instructions.
- F. Color Pigment: Add color pigment to concrete mixture according to manufacturer's written instructions and to result in hardened concrete color consistent with approved mockup.
- G. Concrete Mixtures:
 - 1. Compressive Strength (28 Days): 5000 psi.
 - 2. Maximum W/C Ratio: 0.46.
 - 3. Slump Limit: 4 inches, plus or minus 1/2 inch.
 - 4. Air Content: 5-1/2 percent, plus or minus 1.5 percent at point of delivery for 3/4-inch nominal maximum aggregate size.

5. Admixtures: HRWR (High Range Water Reducing Admixtures) plus VMA (Viscosity Modifying Admixtures) shall be added in accordance with admixture manufacturer's recommendations.

2.08 CONCRETE MIXING

- A. Ready-Mixed Architectural Concrete: Measure, batch, mix, and deliver concrete according to ASTM C 94/C 94M and furnish batch ticket information.
 1. Clean equipment used to mix and deliver cast-in-place architectural concrete to prevent contamination from other concrete.
 2. When air temperature is between 85 and 90 deg F, reduce mixing and delivery time from 1-1/2 hours to 75 minutes; when air temperature is above 90 deg F, reduce mixing and delivery time to 60 minutes.

PART 3 - EXECUTION

3.01 FORMWORK INSTALLATION

- A. General: Comply with Section 033000 for formwork, embedded items, and shoring and reshoring.
- B. Limit deflection of form-facing panels to not exceed ACI 303.1 requirements.
- C. In addition to ACI 303.1 limits on form-facing panel deflection, limit cast-in-place architectural concrete surface irregularities, designated by ACI 347 as abrupt or gradual, as follows:
 1. Class A, 1/8 inch.
- D. Construct forms to result in cast-in-place architectural concrete that complies with ACI 117 (ASI 117M).
 1. Also comply with the following tolerances: Construct forms tightly to prevent loss of concrete mortar.
- E. Construct forms for easy removal without hammering or prying against concrete surfaces. Provide crush or wrecking plates where stripping may damage cast-in-place surfaces. Provide top forms for inclined surfaces steeper than 1.5 horizontal to 1 vertical. Kerf wood rustications, keyways, reglets, recesses, and the like, for easy removal.
 1. Seal form joints and penetrations at form ties with form joint tape or form joint sealant to prevent cement paste leakage.

2. Do not use rust-stained steel form-facing material.
- F. Provide temporary openings for cleanouts and inspection ports where interior area of formwork is inaccessible. Close openings with panels tightly fitted to forms and securely braced to prevent loss of concrete mortar. Locate temporary openings in forms at inconspicuous locations.
- G. Do not chamfer exterior corners and edges of cast-in-place architectural concrete.
- H. Coat contact surfaces of wood rustications and chamfer strips with sealer before placing reinforcement, anchoring devices, and embedded items.
- I. Form openings, chases, offsets, sinkages, keyways, reglets, blocking, screeds, and bulkheads required in the Work. Determine sizes and locations from trades providing such items.
- J. Clean forms and adjacent surfaces to receive concrete. Remove chips, wood, sawdust, dirt, and other debris just before placing concrete.
- K. Retighten forms and bracing before placing concrete, as required, to prevent mortar leaks and maintain proper alignment.
- L. Coat contact surfaces of forms with form-release agent, according to manufacturer's written instructions, before placing reinforcement.
- M. Coat contact surfaces of forms with surface retarder, according to manufacturer's written instructions, before placing reinforcement.
- N. Place form liners accurately to provide finished surface texture indicated. Provide solid backing and attach securely to prevent deflection and maintain stability of liners during concreting. Prevent form liners from sagging and stretching in hot weather. Seal joints of form liners and form-liner accessories to prevent mortar leaks. Coat form liner with form-release agent.

3.02 REINFORCEMENT AND INSERT INSTALLATION

- A. General: Comply with Section 032100 for fabricating and installing steel reinforcement. Securely fasten steel reinforcement and wire ties against shifting during concrete placement.
- B. Set wire ties with ends directed into concrete, not toward exposed concrete surfaces.

3.03 REMOVING AND REUSING FORMS

- A. Formwork for sides of beams, walls, columns, and similar parts of the Work that does not support weight of concrete may be removed after cumulatively curing at not less

than 50 deg F for 24 hours after placing concrete if concrete is hard enough to not be damaged by form-removal operations and curing and protection operations are maintained.

1. Schedule form removal to maintain surface appearance that matches approved mockups.
 2. Cut off and grind glass-fiber-reinforced plastic form ties flush with surface of concrete.
- B. Leave formwork for beam soffits, joists, slabs, and other structural elements that support weight of concrete in place until concrete has achieved 28-day design compressive strength. Remove forms only if shores have been arranged to permit removal of forms without loosening or disturbing shores.
- C. Clean and repair surfaces of forms to be reused in the Work. Do not use split, frayed, delaminated, or otherwise damaged form-facing material. Apply new form-release agent.
- D. When forms are reused, clean surfaces, remove fins and laitance, and tighten to close joints. Align and secure joints to avoid offsets. Do not use patched forms for cast-in-place architectural concrete surfaces.

3.04 JOINTS

- A. Construction Joints: Install construction joints true to line, with faces perpendicular to surface plane of cast-in-place architectural concrete, so strength and appearance of concrete are not impaired, at locations indicated or as approved by Architect/Engineer.
1. Place joints perpendicular to main reinforcement. Continue reinforcement across construction joints unless otherwise indicated.
 2. Form keyed joints as indicated. Embed keys at least 1-1/2 inches into concrete. Align construction joint within rustications attached to form-facing material.
 3. Locate joints for beams, slabs, joists, and girders in the middle third of spans. Offset joints in girders a minimum distance of twice the beam width from a beam-girder intersection.
 4. Locate horizontal joints in walls and columns at underside of floors, slabs, beams, and girders and at the top of footings or floor slabs.
 5. Space vertical joints in walls as indicated. Locate joints beside piers integral with walls, near corners, and in concealed locations where possible.
 6. Use bonding agent at locations where fresh concrete is placed against hardened or partially hardened concrete surfaces.

- B. Contraction Joints: Form weakened-plane contraction joints true to line, with faces perpendicular to surface plane of cast-in-place architectural concrete, so strength and appearance of concrete are not impaired, at locations indicated or as approved by Architect/Engineer.

3.05 CONCRETE PLACEMENT

- A. Before placing concrete, verify that installation of formwork, form-release agent, reinforcement, and embedded items is complete and that required inspections have been performed.
- B. Do not add water to concrete during delivery, at Project site, or during placement unless approved by Architect/Engineer.
- C. Before test sampling and placing concrete, water may be added at Project site, subject to limitations of ACI 301.
 - 1. Do not add water to concrete after adding high-range water-reducing admixtures to mixture.
- D. Deposit concrete continuously between construction joints. Deposit concrete to avoid segregation.
 - 1. Deposit concrete in horizontal layers of depth to not exceed formwork design pressures and in a manner to avoid inclined construction joints.
 - 2. Consolidate placed concrete with mechanical vibrating equipment according to ACI 303.1.
 - 3. Do not use vibrators to transport concrete inside forms. Insert and withdraw vibrators vertically at uniformly spaced locations to rapidly penetrate placed layer and at least 6 inches into preceding layer. Do not insert vibrators into lower layers of concrete that have begun to lose plasticity. Do not permit vibrators to contact forms.

3.06 FINISHES, GENERAL

- A. Architectural Concrete Finish: Match Architect's design reference sample, identified and described as indicated, to satisfaction of Architect/Engineer.
- B. Related Unformed Surfaces: At tops of walls, horizontal offsets, and similar unformed surfaces adjacent to formed surfaces, strike off smooth and finish with a texture matching adjacent formed surfaces.
 - 1. Continue final surface treatment of formed surfaces uniformly across adjacent unformed surfaces unless otherwise indicated.

- C. Maintain uniformity of special finishes over construction joints unless otherwise indicated.

3.07 AS-CAST FORMED FINISHES

- A. Rough-Formed Finish: As-cast concrete texture imparted by form-facing material with tie holes and defects repaired and patched. Remove fins and other projections exceeding specified limits on formed-surface irregularities.
- B. Smooth-Formed Finish: As-cast concrete texture imparted by form-facing material, arranged in an orderly and symmetrical manner with a minimum of seams. Remove fins and other projections exceeding specified limits on formed-surface irregularities. Repair and patch tie holes and defects.
- C. Rubbed Finish: Apply the following to smooth-form-finished as-cast concrete where indicated:
 - 1. Smooth-Rubbed Finish: Not later than one day after form removal, moisten concrete surfaces and rub with carborundum brick or another abrasive until producing a uniform color and texture. Do not apply cement grout other than that created by the rubbing process.
 - 2. Grout-Cleaned Finish: Wet concrete surfaces and apply grout of a consistency of thick paint to coat surfaces and fill small holes. Mix 1-part portland cement to 1-1/2 parts fine sand with a 1:1 mixture of bonding admixture and water. Add white portland cement in amounts determined by trial patches, so color of dry grout matches adjacent surfaces. Scrub grout into voids and remove excess grout. When grout whitens, rub surface with clean burlap and keep surface damp by fog spray for at least 36 hours.
 - 3. Cork-Floated Finish: Wet concrete surfaces and apply a stiff grout. Mix 1-part portland cement and 1-part fine sand with a 1:1 mixture of bonding agent and water. Add white portland cement in amounts determined by trial patches, so color of dry grout matches adjacent surfaces. Compress grout into voids by grinding surface. In a swirling motion, finish surface with a cork float.
- D. Form-Liner Finish: Produce a textured surface free of pockets, streaks, and honeycombs, and of uniform appearance, color, and texture.
- E. Trowel Finish: Apply to all Exposed top of retaining wall, after applying float finish, apply first troweling and consolidate concrete by hand trowel. Continue troweling passes and restraighten until surface is free of trowel marks and uniform in texture and appearance.

3.08 BROOM FINISH

- A. After towel finish the top of the concrete slab on the Pedestrian Bridge, brush with stiff fiber broom over toweled concrete surface in the direction that is perpendicular to both sides of the bridge.

3.09 EXPOSED-AGGREGATE FINISHES

- A. **Scrubbed Finish:** After concrete has achieved a compressive strength of from 1000 to 1500 psi, apply scrubbed finish. Wet concrete surfaces thoroughly and scrub with stiff fiber or wire brushes, using water freely, until top mortar surface is removed, and aggregate is uniformly exposed. Rinse scrubbed surfaces with clean water. Maintain continuity of finish on each surface or area of Work. Remove only enough concrete mortar from surfaces to match design reference sample or mockup.
- B. **High-Pressure Water-Jet Finish:** Perform high-pressure water jetting on concrete that has achieved a minimum compressive strength of 4500 psi. Coordinate with formwork removal to ensure that surfaces to be high-pressure water-jet finished are treated at same age for uniform results.
 - 1. **Surface Continuity:** Perform high-pressure water-jet finishing in as continuous an operation as possible, maintaining continuity of finish on each surface or area of Work. Maintain required patterns or variances in reveal projection to match design reference sample or mockup.
- C. **Abrasive-Blast Finish:** Perform abrasive blasting after compressive strength of concrete exceeds 2000 psi. Coordinate with formwork removal to ensure that surfaces to be abrasive blasted are treated at same age for uniform results.
 - 1. **Surface Continuity:** Perform abrasive-blast finishing in as continuous an operation as possible, maintaining continuity of finish on each surface or area of Work. Maintain required patterns or variances in depths of blast to match design reference sample or mockup.
 - 2. **Abrasive Blasting:** Abrasive blast corners and edges of patterns carefully, using backup boards, to maintain uniform corner or edge line. Determine type of nozzle, nozzle pressure, and blasting techniques required to match design reference sample or mockup.
 - 3. **Depth of Cut:** Use an abrasive grit of proper type and gradation to expose aggregate and surrounding matrix surfaces to match design reference sample or mockup, as follows:
 - a. **Brush:** Remove cement matrix to dull surface sheen and expose face of fine aggregate; with no significant reveal.

- b. Light: Expose fine aggregate with occasional exposure of coarse aggregate and uniform color; with maximum reveal of 1/16 inch.
 - c. Medium: Generally, expose coarse aggregate; with slight reveal, a maximum of 1/4 inch.
 - d. Heavy: Expose and reveal coarse aggregate to a maximum projection of one-third its diameter; with reveal range of 1/4 to 1/2 inch.
- D. Bushhammer Finish: Allow concrete to cure at least 14 days before starting bushhammer surface finish operations.
- 1. Surface Continuity: Perform bushhammer finishing in as continuous an operation as possible, maintaining continuity of finish on each surface or area of Work. Maintain required patterns or variances of cut as shown on Drawings or to match design reference sample or mockup.
 - 2. Surface Cut: Maintain required depth of cut and general aggregate exposure. Use power tool with hammer attachments for large, flat surfaces, and use hand hammers for small areas, at corners and edges, and for restricted locations where power tools cannot reach.
 - 3. Remove impressions of formwork and form facings with exception of tie holes.

3.10 CONCRETE PROTECTING AND CURING

- A. General: Protect freshly placed concrete from premature drying and excessive cold or hot temperatures. Comply with ACI 306.1 for cold-weather protection and with ACI 301 for hot-weather protection during curing.
- B. Begin curing cast-in-place architectural concrete immediately after concrete. Cure according to ACI 308.1, by one or a combination of the following methods that will not mottle, discolor, or stain concrete:
 - 1. Moisture Curing: Keep surfaces continuously moist for not less than seven days with the following materials:
 - a. Water.
 - b. Continuous water-fog spray.
 - c. Absorptive cover, water saturated and kept continuously wet. Cover concrete surfaces and edges with 12-inch lap over adjacent absorptive covers.
 - 2. Moisture-Retaining-Cover Curing: Cover concrete surfaces with moisture-retaining cover for curing concrete, placed in widest practicable width, with sides

and ends lapped at least 12 inches, and sealed by waterproof tape or adhesive. Cure for not less than seven days. Immediately repair any holes or tears during curing period, using cover material and waterproof tape.

3. Curing Compound: Mist concrete surfaces with water. Apply curing compound uniformly in continuous operation by power spray or roller according to manufacturer's written instructions. Recoat areas subjected to heavy rainfall within three hours after initial application. Maintain continuity of coating, and repair damage during curing period.

3.11 FIELD QUALITY CONTROL

- A. General: Contractor is responsible to comply with field quality-control requirements in Section 033000.

3.12 REPAIR, PROTECTION, AND CLEANING

- A. Repair and cure damaged finished surfaces of cast-in-place architectural concrete when approved by Architect/Engineer. Match repairs to color, texture, and uniformity of surrounding surfaces and to repairs on approved mockups.
 1. Remove and replace cast-in-place architectural concrete that cannot be repaired and cured to Architect/Engineer's approval.
- B. Protect corners, edges, and surfaces of cast-in-place architectural concrete from damage, use guards and barricades.
- C. Protect cast-in-place architectural concrete from staining, laitance, and contamination during remainder of construction period.
- D. Clean cast-in-place architectural concrete surfaces after finish treatment to remove stains, markings, dust, and debris.
- E. Wash and rinse surfaces according to concrete finish applicator's written instructions. Protect other Work from staining or damage due to cleaning operations.
 1. Do not use cleaning materials or processes that could change the appearance of cast-in-place architectural concrete finishes.

END OF SECTION 033300

NO TEXT ON THIS PAGE

SECTION 033400 - CONTROLLED LOW STRENGTH MATERIAL (CLSM)

PART 1 - GENERAL

1.01 DESCRIPTION

- A. Provide and install controlled low strength material (CLSM) as indicated and specified.

1.02 PAYMENT

- A. No separate payment shall be made for performing any Work required under this Section. All costs for Work required by this Section shall be included in the applicable unit price as set forth in Section 012901.

1.03 REFERENCES

- A. American Concrete Institute (ACI):

1. 229R: Controlled Low-Strength Materials.
2. 301: Specifications for Structural Concrete.
3. 304R: Guide for Measuring, Mixing, Transporting and Placing Concrete.
4. 305R: Hot Water Concreting.
5. 306R: Cold Water Concreting.
6. 308: Standard Practice for Curing Concrete.
7. 318: Building Code Requirements for Structural Concrete and Commentary.

- B. ASTM International (ASTM)

1. C31: Practice for Making and Curing Concrete Test Specimens in the Field.
2. C33: Specification for Concrete Aggregates.
3. C39: Test Method for Compressive Strength of Cylindrical Concrete Specimens.
4. C94: Standard Specification for Ready-Mixed Concrete.
5. C138: Standard Test Method for Unit Weight, Yield, and Air Content (Gravimetric) of Concrete.
6. C143: Standard Test Method for Slump of Hydraulic-Cement Concrete.
7. C150: Standard Specification for Portland Cement.

8. C172: Practice for Sampling Freshly Mixed Concrete.
9. C231: Test Method for Air Content of Freshly Mixed Concrete by the Pressure Method.
10. C494: Standard Specification for Chemical Admixtures for Concrete.
11. C618: Standard Specification for Coal Fly Ash and Raw or Calcined Natural Pozzolan for Use as a Mineral Admixture in Portland Cement Concrete.
12. C940: Standard Test Method for Expansion and Bleeding of Freshly Mixed Grouts for Preplaced-Aggregate Concrete in the Laboratory.
13. C1064: Test Method for Temperature of Freshly Mixed Portland Cement Concrete.
14. D75: Practice for Sampling Aggregates.

1.04 RELATED SECTIONS

- A. General Conditions Article 4.7 – Shop Drawings and Other Submittals.
- B. Section 012901 – Measurement and Payment.
- C. Section 014300 – Quality Requirements.
- D. Section 016100 – Control of Materials.
- E. Section 017700 – Contract Closeout.

1.05 SUBMITTALS

1. Submit the following items in accordance with General Conditions Article 4.7. CLSM mix design and results of strength tests from trial mixes by the Contractor's testing laboratory firm.
1. Submit manufacturer's Stable-Air Generator Admixture product data, installation instructions, and recommendations for material use.
2. Test and Performance - Submit the following data:
 - a. Any required deviations from prescribed tests and special handling instructions for test specimens.
 - b. Controlled Low Strength Material shall have a maximum strength of 200 psi according to ASTM C39 at 56 days after placement.
 - c. Controlled Low Strength Material shall have minimal subsidence and bleed water which is measured as a final bleeding of less than 2.0 percent (retains

98.0 percent of original height after placement, approximately 1/4-inch per foot of depth) as measured in Section 10 of ASTM C940.

- d. Controlled Low Strength Material shall have a unit weight of 90 - 110 lbs./ft³ measured at the point of placement.

1.06 QUALITY ASSURANCE

- A. Comply with the requirements specified in Section 014300 and as follows.
- B. Do not place CLSM until design mix, material tests and trial batch mix compression test results are approved by the Construction Manager. Approvals are required at least 30 days before placing any production CLSM.
- C. Contractor shall employ an independent testing laboratory, acceptable to the Construction Manager to test conformity of materials to specifications and to design CLSM mixes.
- D. Furnish, pay for, and deliver representative samples of sufficient quantity of cement, aggregates and admixtures required for trial batch mixes to the testing laboratory. Obtain materials from the batching plant that will be supplying production CLSM in conformance with ASTM D75.
- E. Measure all materials for CLSM, including water, with equipment and facilities suitable for accurate measurement and capable of being adjusted in conformance with ASTM C94. Use scales certified by local Sealer of Weights and Measures within one (1) year of use and accurate when static load tested to plus or minus 0.4 percent of total capacity of scale. Batch all materials by weight except admixtures that may be batched by volume.
- F. The testing laboratory will take control test specimens; conduct slump tests and measure air content and temperature in the field.
- G. Methods of Sampling and Testing:
 1. Fresh Concrete Sampling: ASTM C172.
 2. Specimen Preparation: ASTM C31.
 3. Compressive Strength: ASTM C39.
 4. Air Content: ASTM C231.
 5. Slump: ASTM C143.
 6. Temperature: ASTM C1064.
 7. Unit Weight: ASTM C138.

1.07 DELIVERY STORAGE AND HANDLING

- A. Comply with the requirements specified in Section 016100.
- B. Order CLSM from batching plant so that trucks arrive at discharge locations when material is required.
- C. Deliver CLSM to discharge locations in watertight agitator or mixer trucks without altering the specified properties of water-cement ratio, slump, air entrainment, temperature and homogeneity.
- D. Reject CLSM not conforming to this Section, unsuitable for placement, exceeding the time or temperature limitations or not having a complete delivery batch ticket.

1.08 PROJECT/SITE CONDITIONS

- A. Do not place CLSM until conditions and facilities for making and curing control test specimens are in compliance with ASTM C31 and as specified herein.

1.09 MEASUREMENT AND PAYMENT

- 1. Payment shall include all costs to provide and install CLSM as directed by the Construction Manager in accordance with Section 012901.

PART 2 - PRODUCTS

2.01 MATERIALS

- A. Furnish Portland cement conforming to ASTM C150. Use one (1) approved brand from one (1) mill throughout the Contract term unless otherwise approved by the Architect/Engineer. Use Type II for all work, unless otherwise specified.
- B. Water:
 - 1. Use water that is potable and free from injurious amounts of oil, acid, alkali, organic matter or other deleterious substances, and conforms to the requirements for water in ASTM C94, and as specified herein.
 - 2. The maximum water-soluble chloride ion in the water shall not exceed 0.060 percent by weight of cement.
- C. Aggregates:
 - 1. Use aggregates for CLSM conforming to ASTM C33 and to the following requirements in this section.

D. Admixtures:

1. General Requirements: ASTM C494.

E. Fly Ash: Provide fly ash conforming to the following requirements:

1. Class F fly ash conforming to ASTM C618 for chemical and physical properties.
2. Supplemental requirements in percent:
 - a. Maximum carbon content 3 percent
 - b. Maximum sulfur trioxide (SO₃) content 4 percent
 - c. Maximum loss on ignition 3 percent
 - d. Maximum water requirement (as a percent of control) 100 percent
 - e. Fineness, maximum retained on No. 325 sieve 25 percent

2.02 MIXES

- A. Mix design shall produce a consistency that will result in a flowable product at the time of placement that does not require manual means to move it into place.
- B. Provide mix with compressive strength of maximum 200 psi when measured 56 days after placement
- C. Controlled Low Strength Material shall have minimal subsidence and bleed water which is measured as a Final Bleeding of less than 2.0 percent (retains 98.0 percent of original height after placement, approximately 1/4-inch per foot of depth) as measured in Section 10 of ASTM C940 “Standard Test Method for Expansion and Bleeding of Freshly Mixed Grouts for Preplaced-Aggregate Concrete in the Laboratory”.
- D. The fresh unit weight shall be 90 - 110 lbs./ft³, except where specified, and in the absence of strength data the cementitious content shall be a maximum of 150 lbs./cy.

PART 3 - EXECUTION

3.01 INSTALLATION

- A. Batch, mix and deliver CLSM in conformance with ASTM C94. Batch all constituents at a central batching or mixing plant.
- B. Seasonal Conditions:

1. Conform to ACI 305R and as specified herein for hot weather concreting. Do not add retarder admixture to any concrete.
2. Conform to ACI 306R and as specified herein for cold weather concreting. Do not add accelerator admixture to any concrete.

3.02 TRANSPORTING AND MIXING

- A. Conform to concreting procedures set forth in ACI 304R and as specified herein.
- B. Transport CLSM to discharge locations without altering the specified properties of water-cement ratio, slump, air entrainment, temperature, and homogeneity.

3.03 FIELD TESTING

A. General:

1. The Contractor's testing laboratory will use concrete samples taken at the point of agitator or mixer truck discharge to perform slump, air content, and temperature tests and for field control test specimens.

B. Notification of Delivery:

1. Notify the Construction Manager of concrete deliveries a minimum of 48 hours in advance of the scheduled placement. Include within this notification, the mix design and quantity of concrete, method and location of placement, frequency of trucks, ordered slump and time of initial delivery.
2. Furnish delivery batch ticket to the representative from the Construction Manager with each batch delivered to the discharge locations in conformance with ASTM C94.

C. Test Measurements at Discharge:

1. The testing laboratory firm will take measurement of concrete slump, air content and temperature for each 50 cubic yards of each mix design but not less than once a day. The laboratory will conduct the slump, air content and temperature test measurements in conformance with ASTM C143, ASTM C231, and ASTM C1064, respectively.
2. The testing laboratory will submit test reports of field measurements specified above to the Contractor and to the Construction Manager before leaving the jobsite.

D. Control Test Specimens:

1. The testing laboratory will test a minimum of one (1) cylinder at seven (7) days and one (1) cylinder at fourteen (14) days for information; test two (2) cylinders at 28 days for acceptance; and hold two (2) reserve cylinders for verification in conformance with ASTM C31. Strength acceptance will be based on the average of the strengths of the two (2) cylinders tested at 28 days.
2. Laboratory personnel will record truck and load number from the delivery batch ticket, the concrete placement location of each specimen, the date, concrete strength, slump, air content, temperature and truck driver's name.
3. Furnish tightly constructed nonabsorbent test cylinder molds. Use molds of same type and manufacture for all test specimens. Leave molds on cylinders until received in testing laboratory.
4. Furnish boxes for initial curing of test cylinders in conformance with ASTM C31 from time of fabrication until they are transported to the testing laboratory.
5. The testing laboratory will compression test one (1) of each set of specimens at seven (7) days. Immediately notify the Contractor and the Construction Manager if the seven-day strength is deficient. Test the two (2) remaining cylinders at 65 days for concrete strength acceptance. The acceptance test result is the average of the strengths of the two (2) specimens tested at 56 days. The laboratory firm will submit compression test results of the control test specimens to both the Contractor and the Construction Manager. Evaluation and acceptance of concrete shall conform to ACI 301 and ACI 318.

3.04 CURING AND PROTECTION

- A. Protect CLSM from premature drying, hot or cold temperatures, and mechanical injury, beginning immediately after placement and maintain concrete with minimal moisture loss at relatively constant temperature.
- B. Comply with curing procedures set forth in ACI 301, applicable portions of ACI 308 and as specified herein.
- C. Perform hot weather concreting in conformance with ACI 305R and as specified herein when the ambient atmospheric temperature is 80 degrees F or above.
- D. Perform cold weather concreting in conformance with ACI 306R and as specified herein when the ambient atmospheric temperature is 40 degrees F or below.
- E. Protect Controlled Low Strength Material from traffic until sufficient strength has been achieved for further construction operations.

3.05 CONTRACT CLOSEOUT

- A. Provide in accordance with Section 017700.

END OF SECTION 033400

SECTION 033500 - CONCRETE FINISHES AND FLOOR TREATMENT

PART 1 - GENERAL

1.01 DESCRIPTION

- A. This section describes materials and methods of concrete finishes for cast in place concrete structures, including but not limited to the Resist floodwall, and pavements and floor treatments as indicated and in compliance with Contract Documents.

1.02 REFERENCES

- A. American Concrete Institute (ACI):
 - 1. 301: Specifications for Structural Concrete.
 - 2. 302.1R: Construction of Concrete Floors.
 - 3. 303R: Architectural Cast-in-Place Concrete.
 - 4. 303.1: Architectural Cast-in-Place Concrete.
 - 5. 311.4R: Guide for Concrete Inspection.
- B. ASTM International (ASTM):
 - 1. D4263: Standard Test Method for Indicating Moisture in Concrete by the Plastic Sheet Method.
- C. National Sanitation Foundation (NSF):
 - 1. 61: Drinking Water System Components – Health Effects.

1.03 RELATED SECTIONS

- A. General Conditions Article 4.7 – Shop Drawings and Other Submittals
- B. Section 014300 - Quality Requirements
- C. Section 016100 - Control of Materials
- D. Section 017700 - Contract Closeout
- E. Section 017329 – Cutting, Coring and Patching
- F. Section 031000 – Concrete Formwork

G. Section 033000 – Cast-in-Place Concrete

1.04 SUBMITTALS

- A. Shop drawings and other submittals shall be presented in accordance with General Conditions Article 4.7.
- B. Submit manufacturer's product data and surface preparation and application instructions.
- C. Submit manufacturer's color chart for colored floor treatment.
- D. Submit VOC content information for floor treatment products.
 - 1. Submit statement of qualifications, experience, and training of concrete finishing personnel.

1.05 QUALITY ASSURANCE

- A. Prior to concrete construction, develop an outlined quality control program for concrete finishing.
- B. For concrete that will receive additional applied floor finishes, ensure that concrete surface finish and preparation is compatible with the accepted floor finish manufacturer's products. Provide documentation from the floor product manufacturer that specifies the concrete finish and preparation required for proper installation of the floor products.
- C. Make changes in concrete finishes and preparation necessary to accommodate flooring products different from those specified at no additional cost to the DEP. Submit the proposed new finishes and their construction methods to the Construction Manager.

1.06 DELIVERY, STORAGE AND HANDLING

- A. Comply with the requirements in Section 016100.

PART 2 - PRODUCTS

2.01 GRAFFITI GUARD PROTECTANT WATER REPELLENT

- A. General: Throughout the construction phase, prior to final acceptance of the Work, all graffiti must be erased within twenty-four (24) hours in accordance with Crime Prevention Through Environmental Design (CPTED) strategies.
- B. After curing of concrete has been completed, apply a modified, "neat" silane system that offers invisible protection and low volatility, suitable for vertical and horizontal

concrete surfaces. Contractor shall provide weatherproofing and protection from graffiti without altering the natural appearance of cast-in-place visible concrete elements.

1. Basis of Design: "SLX100" as provided by ProSoCo, Lawrence, KA, CSL Silicones Inc., Guelph, ON, ParaCoat Technologies, Inc., Johnstown, PA or approved equal.
2. Clear - Invisible that will not leave a Glossy Final Finish.

2.02 FLOOR SEALERS AND DENSIFIERS

- A. Shall contain silicate and siliconate and be VOC compliant.
- B. Products:
 1. Dayton Superior: Sure Hard Densifier J17
 2. Euclid Chemical Company: Euco Diamond Hard
 3. BASF Construction Chemicals: Kure-and-Harden, or approved equal.

2.03 CLEAR FLOOR HARDENER

- A. Provide a colorless, aqueous solution of zinc and magnesium fluorosilicate.
- B. Products:
 1. Euclid Chemical Company: Eucosil.
 2. BASF Construction Chemicals: Sonosil
 3. L & M Construction Chemicals, Inc: Chem Hard, or approved equal.

2.04 NONSLIP AGGREGATE FLOOR FINISH

- A. Minimum 50 percent aluminum oxide content.
- B. Products:
 1. Dayton Superior: Emery Non-slip
 2. BASF Construction Chemicals: Frictex-NS
 3. L&M Construction Chemicals, Inc: Grip It, or approved equal.

2.05 DRY SHAKE METALLIC FLOOR HARDENER

A. Products:

1. Euclid Chemical Company: Surfex
2. Dayton Superior: Ferro Tuff
3. BASF Construction Chemicals: Master Plate 200, or approved equal.

2.06 EPOXY BONDING AGENT

- A. Shall be in accordance with Section 033000.

2.07 CONCRETE REPAIR MATERIAL

- A. Concrete repair methods and products shall be in accord with Section 017329 and submitted to the Construction Manager for approval of the Engineer.

PART 3 - EXECUTION

3.01 CONCRETE FINISHES:

- A. Do not use curing compound where epoxy, urethane, mortar bed, grout, additional concrete or other toppings or adhesive will be applied.
- B. Do not sprinkle with dry cement or add water when finishing concrete surfaces.
- C. Finish concrete surfaces in accordance the types and tolerances requirements specified under Section 033000.
 1. E-2: Strike smooth and float to an F-3 or F-4 finish.
- D. Protect finished concrete surfaces from damage by construction equipment, materials, curing procedures and rain or running water.

3.02 FINISHING OF FORMED SURFACES

- A. Cure surfaces until finishing and repairing are completed.
- B. Conform to the requirements specified in Section 031000 for tolerances for formed surfaces.

3.03 FINISHING OF UNFORMED SURFACES

- A. Perform finish work in accordance with the requirements of the Construction Manager.

- B. Provide steel-trowel finish to all top, horizontal and inclined surfaces not otherwise specified or indicated. This includes concrete fills and toppings and floors. Provide hand steel-trowel finish to all surfaces such as weirs or walls over which liquids will flow.
- C. Provide broom finish to exterior walkways, exterior stairs, entrance platforms and loading docks.

3.04 FLOOR TREATMENT APPLICATION

- A. Prepare concrete surface in accordance with manufacturer's printed instructions.
- B. Perform concrete moisture testing in accordance with product manufacturer's requirements.
- C. Apply floor treatment in accordance with product manufacturer's written instructions.
- D. Provide mock ups for Nonslip aggregate floor finish and Dry Shake Hardener floor finish. Minimum size of mock up sample shall be 2 feet x 2 feet.
- E. Colors for colored floor treatment shall be as selected by Construction Manager.
- F. Apply hardener to risers and treads of concrete stairs.

3.05 CONCRETE REPAIR

- A. Surface Defects:
 - 1. Do not repair defects until concrete has been inspected by the Construction Manager. Repair of concrete surfaces shall be in accordance with Section 017329.
 - 2. Repair defects including, air voids and bug holes with a nominal diameter or depth greater than one-eighth (1/8")-inch, honeycombed areas, visible construction joints, fins, burrs, color and texture variations and other defects as determined by the Construction Manager. Make concrete repairs with a polymer modified cementitious repair mortar in accordance with Section 017329 to produce a concrete surface uniform in color and texture and free of all irregularities.
- B. Crack Repair:
 - 1. Shall be in accordance with the applicable requirements contained in Sections 017329 and 033300.
- C. Tie-hole Repair:

1. Shall be in accordance with the applicable requirements contained in Sections 017329 and 033300.

3.06 CLOSEOUT ACTIVITIES

- A. Provide in accordance with Section 017700.

END OF SECTION 033500

SECTION 034500 – SITE PRECAST ARCHITECTURAL CONCRETE

PART 1 - GENERAL

1.01 DESCRIPTION

- A. Provide precast architectural concrete as indicated and in compliance with Contract Documents. Precast architectural concrete elements are a delegated design item as per paragraph 1.06 A herein.
 - 1. Precast concrete steps

1.02 PAYMENT

- A. No separate payment shall be made for performing any Work required under this Section. All costs for Work required by this Section shall be included in the applicable Cove Park lump sum as set forth in Section 012901.

1.03 REFERENCES

- A. ASTM — American Society for Testing and Materials (ASTM):
 - 1. ASTM A 185-90a - Specification for Steel Welded Wire, Fabric, Plain, for Concrete Reinforcement.
 - 2. ASTM A 615-92b - Specification for Deformed and Plain Billet-Steel Bars for Concrete Reinforcement.
 - 3. ASTM C20 - Standard Test Method for Hydrated Lime for Masonry Purposes
 - 4. ASTM C 33 - Standard Specification for Concrete Aggregates.
 - 5. ASTM C144 - Standard Test Method for Aggregate for Masonry Mortar.
 - 6. ASTM C 150 - Standard Specification for Portland Cement.
 - 7. ASTM C270 - Standard Specification for Mortar for Unit Masonry
 - 8. STM C 330-89 - Specification for Lightweight Aggregates for Structural Concrete.
 - 9. ASTM C 979-82 -Specification for Pigments for Integrally Colored Concrete.
 - 10. ASTM D1751 - Standard Specification for Preformed Expansion Joint Filler.
- B. ACI – American Concrete Institute

1. ACI 301 - Standard Specifications for Structural Concrete.
2. ACI 318 - Building Code Requirements for Structural Concrete.

C. PCI – Precast/Prestressed Concrete Institute

1. PCI MNL 117 - Manual for Quality Control for Plants and Production of Architectural Precast Concrete Products.

1.04 RELATED SECTIONS

- A. General Conditions Article 4.7 – Shop Drawings and Other Submittals
- B. Section 012901 Measurement and Payment
- C. Section 014300 – Quality Requirements
- D. Section 016100 – Control of Materials
- E. Section 017423 – Cleaning Up
- F. Section 017700 – Contract Closeout
- G. Section 033000 – Cast-In-Place Concrete
- H. Section 079200 – Joints Sealant
- I. Requirements from the following section also apply to this Section
 1. Section 321560 – Bound Crushed Stone Surfacing

1.05 DEFINITIONS

- A. Acceptance: Wherever the terms “acceptance” or “accepted” are used herein, they mean acceptance by Architect/Engineer in writing.

1.06 REQUIREMENTS

- A. Contractor Design: All work associated with precast elements is to be performed as a delegated design and build. Contractor is to provide final design, engineering, fabrication.
 1. General: Design and engineering of precast elements to be developed in accordance with building codes for structural loads and capacities.
 2. Contractor to provide all calculations and analysis, including but not limited to:
 - a. Base plates and bolt sizes.

- b. Post design.
 - c. Reinforcing.
 - d. Concrete mix designs.
 3. Contractor is to coordinate work of others associated to features attached to precast including but not limited to:
 - a. Decorative metal railings
 - B. Furnish all transportation, labor, materials, and equipment to perform the following: Furnish and install precast concrete units and accessories necessary to complete the work.
 - C. Provide anchoring system, for system that is capable of sustaining forces generated by gravity loads, live loads and stresses induced by thermal movement, acting separately or in combination, within the following parameters:
 1. For Precast: Do not exceed allowable working stresses of precast. Determine the capacity of precast to sustain anchor loads.
 2. For Metal Components: Without exceeding allowable stresses established by the following: for Stainless Steel Anchors in Tension, Shear and Compression: 54 percent of yield stress.
 3. Provisions of fabrication and Erection tolerances: Detail and fabricate connections of precast-cladding system to the underlying cast-in-place concrete footing so that allowance is made for not only fabrication and erection tolerances, but also structural deflections from loads and other causes.
 - D. Control of Corrosion and Staining: Prevent galvanic and other forms of corrosion as well as staining by insulating metals and other materials from direct contact with incompatible materials. Use materials that are non-staining to exposed surfaces of concrete and joint materials.
- 1.07 SUBMITTALS
- A. Submit the following in accordance with General Conditions Article 4.7.
 - B. Product Data:
 1. Submit product data for all manufactured materials and products, including but not limited to precast elements, stair nosing's warning strip, anchor hardware, epoxy adhesive, mortar, grout, sealers and cleaner. Include manufacturer's name and address, specific trade names; catalog numbers complete with installation instructions, illustrations and descriptive literature indicating colors, textures and finishes available.

2. Submit MSDS data for all manufactured materials and products for the safe handling of the specified materials and products.

C. Shop Drawings:

1. Submit engineered and stamped shop drawings for all delegated design for review and approval for design intent prior to mockup and/or fabrication.
2. Provide drawings indicating all dimensions of all sizes of precast units depicted in the drawings pertaining to this section. Drawings should indicate in-place location, fabrication details, plans, elevations, anchorages, reinforcement, connection details and methods, dimensions, finishes, relationships to adjacent materials, erection and placement, and all other detailed information required for the work. Indicate verified field dimensions and identify cut unit conditions. Show complete shop drawings locating and identifying each precast unit in the finished work.
3. Submit casting and setting drawings indicating sizes, dimensions, sections, reinforcing steel and profiles of all precast unit types, arrangement and provisions for jointing, supporting, anchoring and bonding precast concrete; and other details showing relationships with, attachment to, and reception of, related work. Indicate recesses for all included fixtures and imbeds with associated components and conduit and wiring and sleeving as required.
4. Drawings shall be provided in formats including but not limited to 3D model (Rhino), AutoCAD & PDF format for review.

D. Samples: The following samples shall be submitted for approval prior to fabrication. Accepted samples become the standard of acceptance for the work.

1. Precast Concrete Steps:
 - a. Three (3) 18-inch by 18-inch x 6-inch three-sided units of typical precast unit. Unit sample shall include accepted finish, color and edges for top and sides. Samples shall demonstrate quality and consistency of material and appearance that can be expected in the finished installation. Samples should be provided with sealer pre-applied to precast unit.
2. Grout:
 - a. Provide three (3) 3/8-inch wide by 12-inches long samples of specified grout in color and finish indicated.
3. Sealant:
 - a. Provide three (3) 3/8-inch wide by 12 inches long samples of specified sealant in color and finish indicated.

- E. Mix Designs: Submit concrete mix designs for each type and finish of precast step unit depicted in the drawings pertaining to this Section.
 - 1. Cementitious Material: Use the following cementitious materials, of the same type, brand, and source throughout the Project:
 - a. Portland Cement: ASTM C 150, Type I, II or III Portland Cement. Drawings.
 - b. Fly Ash: AASHTO M 295; except that the loss on ignition shall not exceed 3 percent.
 - c. Ground Granulated Blast-Furnace Slag: ASTM C 989, Grade 100.
 - 2. Normal-Weight Aggregates: ASTM C 33, Class 4S coarse aggregate, uniformly graded. Provide aggregates from a single source.
 - 3. Maximum Coarse-Aggregate Size: AASHTO M 80, Class A. 19 mm (3/4-inches) nominal.
 - a. Fine Aggregate: AASHTO M 6, Class B. A minimum sand equivalent value of 75 when tested in accordance with AASHTO T 176, Alternate Method No. 2.
 - F. Test Reports:
 - 1. Compatibility and adhesion test reports from latex additive manufacturer indicating that precast concrete units have been tested for compatibility and adhesion with mortar and grout containing latex additives. Include latex additive manufacturer's interpretation of test results relative to mortar and grout performance and recommendations for installation practices needed to obtain adhesion.
 - G. Maintenance Instructions: Submit copies of manufacturer's specified maintenance practices for precast unit surfaces and joints.
 - H. Proof of Work Experience: Precast Manufacturers: Submit project lists, including reference names, phone numbers and project dates.
 - I. Calculations: Submit structural calculations for precast units and their connections to the structure; calculations shall be stamped and signed by a Professional Engineer registered in the State of New Jersey.
- 1.08 QUALITY ASSURANCE
- A. Comply with the requirements specified in Section 014300.
 - B. Manufacturer Qualifications: Company shall have a minimum of ten (10) years experience in producing units similar to those required for this Project, with sufficient production

capacity to produce and deliver required units without causing delay in work. Company shall be presently specializing in the manufacture of the type of product shown on the Contract Drawings. Company shall have experience with 3D modelling software capable of producing the 3D shop drawing requirements. Company shall also have and submit:

1. Information on three past jobs that they manufactured of similar size and design.
 2. Proof of certified plant and member of one of the following:
 - a. Architectural Precast Association (APA).
 - b. Precast/Prestressed Concrete Institute (PCI), Group A1.
 - c. Or show sufficient Quality Control Program certified by a New Jersey Engineer.
- C. Installation Subcontractor Qualifications: Company shall have a minimum of five (5) years' experience installing precast unit systems similar to those required for this Project. Company shall also have and submit:
1. Submit information on three past jobs that they installed of similar size and design. Job references shall be provided including project name and description, Client/Contractor names, postal address, phone, fax, and email address.
 2. Submit a copy of Subcontractor's current certificate from the Concrete Pavement Institute Concrete Paver Installer Certification program.
- D. Single-Source Responsibility: Obtain each color, type, and variety of precast unit, joint material, and setting materials from a single source with resources to provide products and materials of consistent quality in appearance and physical properties without delaying progress of the Work.
- E. Pre-Installation Conference: Prior to mockup installation, the Contractor shall coordinate and arrange a Pre-Installation Conference meeting between the Architect/Engineer, Construction Manager, Contractor, Installation Subcontractor, and any other necessary parties to review scope of work within this section.
- F. Regulatory Requirements: Contractor, Manufacturer, and Installer to meet requirements of applicable laws, codes, and regulations required by authorities having jurisdiction over Work.
- G. Mock-ups:
1. Provide mockup of each type of installation using approved materials and specified methods of installation. Mockups are constructed to verify selections made under sample submittals; to demonstrate aesthetic effects and, where indicated, qualities of materials and execution; to review coordination, testing, or operation; to show

the interface between materials, and to demonstrate compliance with specified installation tolerances. Mockups are for evaluation of application workmanship and determine the standard for all work under the scope of work will be judged. Before installing precast architectural concrete units, build mockups to verify selections made under sample Submittals and to demonstrate aesthetic effects and qualities of materials and execution. Obtain final acceptance prior to start of the installation of work.

- a. Mockups are not samples and are to be fully complete showing all aspects of work as required for review.
- b. Mockup Plan: Prior to the construction of mockup contractor to provide dimensional drawings detailing mockup size, and items and materials that will be included in the proposed mockup. Submit drawings for review and approval before construction mockup.
- c. Mockup Types: Mockups are to be reviewed and approved by Architect/Engineer.
 - 1) Preliminary Mockups: Mockups that are partial fabrications to understand specific sections, conditions or component of the work. This includes a partial fabrication of piece to a miniature model of proposed work.
 - 2) Off-Site Mockups: Mockups of production work that is anticipated for installation but to be reviewed before shipment. Contractor to make arrangements for Architect/Engineer to review fabricated units prior to shipment.
 - 3) First-in-Place Mockups: Mockups that can be part of finish work pending final approval.

2. Schedule of Mockups:

- a. Preliminary Mockup for Color and Finish Verification of product to be used in the final mockup: Construct a preliminary mockup 18 inch wide of the tread width and riser height of the precast step unit demonstrating color and finish of the precast step product. Retain approved preliminary mockup sample for comparison to final mockup.
- b. Final Mockup: Construct a minimum 4-foot-wide installation of precast steps including no less than three (3) risers. Final mockup to be approved by the Landscape Architect and Construction Manager.
- c. Mockup types to include:

- 1) Off-site installation: An area that is constructed outside of the field of work and to be protected throughout the project. Provide no less than three full size step units. The mock-up to demonstrate the full interface of all edge and geometry conditions including at resin bound aggregate paving, at impervious concrete path, and adjacent to wall type 2 and concrete amphitheater seat with wood top including plan geometries as shown on the Contract Documents. This mockup once approved it shall be the standard from which the work will be judged.
- 2) First-in-Place Mockups: These are locations in the site to verify that installation is in conformance to the approved Off-site mockup. Mock-up may be retained as a part of the finished work upon approval by Landscape Architect and the Construction Manager. If mock-up is not retained, remove and dispose of mock-up prior to the completion of the project. Provide no less than three full size step units.
3. Build mockups in the location and of the size indicated or, if not indicated, as directed by Construction Manager.
4. Notify Architect/Engineer seven days in advance of dates and times when mockups will be constructed and ready to be reviewed.
5. Mockups are to be prepared far enough in advance to allow review and acceptance. Contractor to provide suitable time to allow in construction schedule for new mockups due to rejections.
6. In presence of Architect/Engineer, damage part of an exposed face for each finish, color, and texture, and demonstrate materials and techniques proposed for repairs to match adjacent undamaged surfaces.
7. Maintain mockups during construction in an undisturbed condition as a standard for judging the completed Work.
8. Demolish and remove mockups when directed.
9. Include example of grout and sealant joints as detailed and specified.
10. Upon request the Architect/Engineer may require minor modifications to be made to the mock-ups. The revised mock-ups shall be provided at the Contractor's expense.
11. Once the mock-up has been approved by the Architect/Engineer, Contractor shall retain and protect approved mock-up, as it will serve as the standard from which the work will be judged, and a continuous reference for installers and contractors during the work. As such, mock-ups shall be located within a ten-minute walk of the job site and must be protected in place for the duration of the project.

12. Damaged, deficient, and/or unapproved mockups shall be completely removed from the jobsite immediately, at the Contractor's expense.
13. Contractor shall construct as many mock-ups as required to comply with the contract documents, at no additional cost to the DEP.
14. All mock-ups are subject to approval by Landscape Architect and the Construction Manager.

1.09 DELIVERY, STORAGE AND HANDLING

- A. Comply with the requirements specified in Section 016100.
- B. Loading and Shipment:
 1. Carefully pack the units for shipment free from stains and other deleterious material.
 2. Exercise precautions against damage in transit.
- C. Storage:
 1. Store units on non-staining wood skids or pallets at least four inches above grade.
 2. Place and stack skids and units to distribute weight evenly and to prevent breakage or cracking.
 3. Protect and store units from weather and soiling with waterproof non-staining covers or enclosure, but allow air to circulate around units.
- D. Handling:
 1. Deliver materials to the jobsite in such a manner that no damage occurs to the product.
 2. Comply with manufacturer's ordering instructions and lead-time requirements to avoid construction delays.
 3. Delivery: Deliver materials in manufacturer's original, unopened, undamaged containers packaging with identification labels intact. Packaging shall contain manufacturer's name, customer name, order, identification number, and other related information.
 - a. Coordinate delivery and schedule to minimize interference with normal use of buildings adjacent to work.

- b. Deliver, unload, and handle precast units in such a manner that no damage occurs to the product.
 - c. Handle and store precast concrete units in accordance with manufacturer's recommendations.
4. Notify the Construction Manager 7 Calendar Days prior to the time of delivery and time of obtaining materials from storage site. Make inventory of materials in the presence of the Construction Manager.
5. Store materials and products in a dry and protected location. Protect from drying, breaking, rusting, deformation, staining, and moisture damage. Protect from mud, dirt, and other foreign materials. Store units off the ground on nonstaining skids made of non-chemically treated wood. Cover units on all sides and bottom with waterproof paper, clean canvas or polyethylene sheeting.
6. Handle units to prevent chipping, breakage, soiling or other damage. Do not use pinch or wrecking bars without protecting edges of units with wood or other rigid materials. Lift with wide-belt type slings wherever possible. Do not use wire rope or ropes containing tar or other substances which might cause staining. If required, use wood rollers and provide cushion at end of wood slides.
7. Protection: Take care to ensure that precast units are not stained or chipped. Replace damaged or defective precast units at no additional cost to DEP.
8. Cover mortar sand and grout sand with waterproof covering if needed to prevent exposure to rainfall or removal by wind. Secure the covering in place.
9. Cement delivered to job shall be packed in strong paper or jute bags with brand name and manufacturer's name stamped thereon. Cement shall be stored under cover, in a dry location, and should it become wet or show signs of caking or deterioration of any kind, it shall be immediately removed from the site. Protect concrete materials from contamination.

1.10 ENVIRONMENTAL CONDITIONS

- A. The use of water for work, cleaning or dust control, and the like shall be contained and controlled and shall not be allowed to come into contact with the public. Provide barricades or screens to protect the public.
- B. Do not install in rain or snow.
- C. Do not install when outside temperature is below 45 degrees Fahrenheit.
- D. Hot-Weather Requirements: Protect precast stair unit work when temperature and humidity conditions produce excessive evaporation of setting beds and grout. Provide

artificial shade and wind breaks and use cooled materials as required. Do not apply mortar to substrates with temperatures of 100 degrees Fahrenheit and above.

- E. Disposal of any liquids or other materials of possible contamination shall be made in conformance with federal state and local laws and ordinances.
- F. Cleaning materials shall have code acceptable low VOC solvent content and low flammability if used on the site.

1.11 VERIFICATIONS OF DIMENSIONS AND QUANTITIES

- A. Verify scaled dimensions and quantities prior to start of work.
- B. Notify the Construction Manager of discrepancies between Contract Drawings and Specification Sections and actual job site conditions which would affect the execution of the installation work. Do not work in areas where discrepancies occur until instructed by the Landscape Architect.

1.12 WARRANTY

- A. General Description: In addition to manufacturer's guarantees or warranties, Work shall be warranted for one year from the date of Substantial Completion against defects in materials and workmanship.
- B. Other Items Covered: Warranty shall cover repair of damage to any materials and workmanship resulting from defects in precast concrete specialty materials and workmanship.

1.13 MAINTENANCE INSTRUCTIONS

- A. Instructions shall contain precast unit suppliers recommended cleaning, materials, and applications methods, including precautions in use of cleaning materials that may be detrimental to surfaces if improperly applied.
- B. Instruct City of Hoboken's personnel in maintenance procedures.

PART 2 - PRODUCTS

2.01 COLOR AND FINISH SELECTION

- A. Precast Step Unit
 - 1. Custom blended concrete with integral color, specialized aggregates and texture. Finish exposed-face surfaces of precast architectural concrete units to match approved design reference sample as in this Section.

- a. General: Impart by form liners or inserts to provide surfaces free of pockets, streaks, and honeycombs, with uniform color and texture. Any air-pockets in the surface of the precast must be sacked or filled to match.
- b. Color: Light Grey.
 - 1) Basis of Design: Wausau Tile Precast Concrete Tread and Riser – Color A31 Fog, Stepstone, Inc., ParaCoat Technologies, Inc.
 - 2) Or approved equal.
- c. Exposed-Face Finish: Light Sand Blast.
- d. Finish unexposed surfaces of precast architectural concrete units by float finish.

2.02 STAIR NOSING WARNING STRIP

- A. Fabricate of material, color, sizes and configurations shown on the Contract Drawings. Lengths shall be as required to accurately fit each opening or conditions.
 1. Solid abrasive type units without ribs.
 2. Cast into architectural precast stair as per the Contract Drawings.

2.03 ARCHITECTURAL FORMLINER

- A. General: Custom liner system made of elastomeric urethane design for multiple uses maintaining quality of imprint from each time used.

2.04 PERFORMANCE REQUIREMENTS

- A. Delegated Design: Engage a qualified professional engineer to design precast structural concrete units.
- B. Design Standards: Comply with ACI 318 and with design recommendations in PCI MNL 120, "PCI Design Handbook - Precast and Prestressed Concrete," applicable to types of precast structural concrete units indicated.
- C. Structural Performance: Provide precast structural concrete units and connections capable of withstanding the design loads identified on the Contract Drawings.

2.05 MATERIALS

- A. Precast Concrete Finish
 1. Match Architect/Engineer's Approved Sample

- B. Cement: ASTM C 150, Type I, II or III Portland Cement. 5 percent – 7 percent air entrained.
- C. Aggregate for Regular Weight Concrete: ASTM C 33, with 3/4-inch, (0.64 cm), maximum size.
- D. Reinforcing Bars: ASTM A 615, grade 60, galvanized, deformed billet-steel bars, clean and free from rust, scale, or coating that will reduce bond.
- E. Angle Iron: Refer to Section 055001.
- F. Welded Wire Fabric: ASTM A 185.
- G. Water: Clean, potable, concrete mixing water free from injurious amounts of salts, oils, acids, alkalis, organic materials or other deleterious substances which could cause staining.
- H. Coloring Admixtures for Colored Concrete: ASTM C 979, SIKA Scofield Chromix Admixture, “custom color”, group II category, Direct Colors Co., Redi-Mic Colors, Inc., or approved equal to match accepted sample for architectural precast concrete.
- I. Anchor Bolts, Threaded Inserts, Nuts, Washers and Adhesive: 316 Stainless steel bolts, nuts and washers with structural adhesive anchor systems; Hilti HVA/HAS-SS, or accepted substitute.
- J. Shims: ASTM D 2000, neoprene rubber; 80 – 90 pounds per cubic foot density, minus 40 to plus 200 degrees Fahrenheit, , temperature resistance, thickness as required to shim, or accepted equal.
- K. Dowels: 316 Stainless steel dowels as per the Contract Drawings.
- L. Micro-Reinforcement: ASTM C 1116, 100-percent nylon.
- M. Shrink-Reducing Admixture
- N. Water

2.06 CONCRETE MIX

- A. Minimum Compressive Strength at 28 Days: 4,000 pounds per square inch, as determined by ASTM C 140.
- B. Absorption: Five percent (5%) maximum, as determined by ASTM C 140.
- C. Coloring Agent: Achieve color by integrally mixing color admixture with concrete, as specified by the color admixture manufacturer’s current printed instructions.

- D. Micro-Reinforcement: Incorporate into mix as specified by the manufacturer's current printed instructions.

2.07 FABRICATING

A. Molds:

1. Provide a finish matching the accepted sample.
2. Cast elements in molds of rigid construction, accurate in detail with precise corners and arises, and so designed as to provide a close control of dimensions and details as indicated on the accepted Shop Drawings.
3. Prior to casting of pre-cast elements, fill, grind, file and straighten mold surfaces to provide a finished concrete surface that is smooth, dense and free of honeycombing, air pockets, offsets, sinkage's, joint marks and other irregularities.

B. Casting:

1. Cast concrete using methods and equipment that meet requirements of industry standards for this type of Work.
2. Perform Work at manufacturer's plant only.
3. Handle concrete to prevent segregation of materials, and vibrate either internally or externally, to achieve proper compaction, finish and distribution of concrete.
4. Take precautions to keep the reinforcing steel in the proper location during placing and consolidation of the concrete.
5. Accurately place embedded items and maintain them in their proper location during the casting operation.

C. Dimensional Tolerances:

1. Height and Width: Plus or minus 1/8 inch.
2. Thickness: Plus or minus 1/8 inch.

D. Color: Integral color as selected by the Architect/Engineer.

E. Finish: Light Sandblast finish to match accepted submittal.

F. Curing:

1. Meet requirements of industry standards for this type of work.

2. Do not remove elements from the molds until they have reached a compressive strength of 2,000 pounds per square inch.

G. Waterproofing: Per manufacturer's recommendations.

2.08 SAND

- A. Clean, hard, durable, and conform to ASTM C33. For concrete setting beds, 100 percent shall pass a No.4 screen with not more than five percent passing a 100-mesh screen. For grout, 100 percent shall pass a 30-mesh screen with not more than 5 percent passing a 100-mesh screen. Fine aggregate shall conform to ASTM C33.

2.09 PORTLAND CEMENT MORTAR SETTING BED MATERIALS

- A. Portland Cement: ASTM C150, Type I or II.
- B. Hydrated Lime: ASTM C207, Type S.
- C. Aggregate: ASTM C144 with a fineness module of 2.25 plus or minus 0.10.
- D. Latex additive (water emulsion) described below, serving as replacement for part or all of gauging water, of type specifically recommended by latex additive manufacturer for use with job-mixed Portland cement and aggregate and not containing a retarder.
- E. Reinforcing Wire Fabric: Stainless Steel welded wire fabric, 2 inches by 2 inches– W0.3 by W0.3 (16 ASW gage or 0.0625-inch diameter); comply with ASTM A185 and ASTM A82 except for minimum wire size.
- F. Water: Clean, free of materials detrimental to strength or bond of mortars.

2.10 MORTAR AND GROUT MIXES.

- A. General: Comply with referenced standards and with manufacturer's instructions relative to mix proportions, mixing equipment, mixer speeds, mixing containers, mixing time, and other procedures needed to produce setting bed and joint materials of uniform quality and with optimum performance characteristics. Discard mortars and grout when initial sets are reached.
- B. Cement Paste Slush Coat: Mix slush coat to a consistency similar to that of thick cream and consisting of either neat cement and water or cement, sand, and water.
- C. For latex-modified Portland cement setting bed mortar, substitute latex admixture for part or all of water per directions of latex additive manufacturer.
- D. Portland Cement/Lime Setting Bed Mortar: Type M complying with ASTM C270 Proportion Specification.

- E. Latex-Modified Portland Cement Setting Bed Mortar: Proportion and mix Portland cement, aggregate, and latex additive for setting bed to comply with directions of latex additive manufacturer and as necessary to produce stiff mixture with a moist surface when bed is ready to receive precast units.
- F. Latex-Modified Portland Cement Slurry Bond Coat: Proportion and mix Portland Cement, aggregate, and latex additive for slurry bond coat to comply with directions of latex additive manufacturer.
- G. Latex-Modified Portland Cement Grout: Add latex additive to dry grout mix in proportion and concentration recommended by latex additive manufacturer.
- H. Job-Mixed Colored Pigmented Grout: Select and proportion pigments with other ingredients to produce color required. Do not exceed pigment-to-cement ratio of 1 to 10, by weight. Proportion cement and aggregate to comply with directions of latex additive manufacturer.
- I. Job-Mixed Colored Aggregate Grout: Produce color required by combining colored aggregates with Portland cement of selected color. Proportion cement and aggregate to comply with directions of latex additive manufacturer.

2.11 GROUT MATERIALS

- A. Sand-Cement Grout: Portland cement, ASTM C 150, Type I, and clean, natural sand, ASTM C 144:
 - 1. Mix at ratio of 1 part cement to 2-1/2 parts sand, by volume, with minimum water required for placement and hydration.
 - 2. Colors: to match adjacent precast.
 - 3. Water: Clean, potable, free of materials detrimental to strength or bond of grout.

2.12 MORTAR MATERIALS

- A. Latex-Modified Portland Cement Setting Mortar: Flexible polymer-modified Portland cement mortar, complying with ANSI A118.4. Proportion and mix Portland cement, aggregate, and latex additive to comply with latex-additive manufacturer's written instructions.
 - 1. Latex Additive: Styrene butadiene rubber.
 - 2. Latex Additive: Acrylic resin.
 - 3. Dry Mortar Mixture: Furnish dry mortar ingredients in the form of a pre-blended mix.

4. Portland Cement: ASTM C150, Type I or II, of natural color or white as required to produce color indicated.
5. Aggregate: ASTM C144, graded to comply with latex additive manufacturer's requirements.
6. Colored Mortar Pigments for Grout: Natural and synthetic iron oxides and chromium oxides, compounded for use in mortar and grout mixes. Use only pigments that have proven through testing and experience to be satisfactory for use in Portland cement grout.
7. Colors: to match adjacent precast.
8. Water: Clean, potable, free of materials detrimental to strength or bond of grout.

2.13 EXPANSION JOINT MATERIALS

- A. Expansion Joint Materials: Pre-molded expansion joint filler shall conform to ASTM D1751-6B, size as shown on Drawings. "Denver Foam" backer rod by DFC, "Sonofoam" backer rod by Sonneborn, backer rod by Best Materials Inc., backer rod by MM Systems or approved equal.
- B. Expansion joint sealant: Refer to Section 079200
 1. Color to match the adjacent precast concrete color

2.14 GRAFFITI GUARD PROTECTANT WATER REPELLENT

- A. General: During the OMR phase, any graffiti must be erased within 24 hours in accordance with Crime Prevention Through Environmental Design strategies.
- B. Modified, "neat" silane system that offers invisible protection and low volatility, suitable for vertical and horizontal concrete surfaces. Shall provide weatherproofing and protection from graffiti attaches without altering the natural appearance of precast architectural concrete elements.
 1. Basis of Design: "SLX100" as provided by ProSoCo, Lawrence, KA, CSL Silicones Inc., Guelph, ON, ParaCoat Technologies, Inc., Johnstown, PA or approved equal.
 2. Clear – Invisible that will not leave a Glossy Final Finish
 3. Specific Gravity: 0.913 to 0.930
 4. Active Content: 93 percent
 5. Total Solids: 58 percent (ASTM D5095)

6. Flash Point: 108 degrees F (42 degrees C) ASTM D 3278
7. VOC Content: Maximum VOC Content 350 grams per Liter.

PART 3 - EXECUTION

3.01 EXAMINATION

- A. Verification of Conditions: Examine site and verify that conditions are suitable to receive Work and that no defects or errors are present which would cause defective installation of products or cause latent defects in workmanship and function.
- B. Notification of Unsuitable Conditions: Before proceeding with Work, notify DEP and Construction Manager in writing of unsuitable conditions.
- C. Do not install precast concrete units until supporting concrete has attained the minimum design compressive strength.

3.02 EXISTING CONDITIONS

- A. Use every possible precaution to prevent damage to existing conditions to remain such as structures, utilities, irrigation systems, plant materials and paving on or adjacent to the site of the Work.
- B. Provide barricades, fences or other barriers as necessary to protect existing conditions to remain from damage during construction.
- C. Do not store materials or equipment, permit burning, or operate or park equipment under the branches of existing plants to remain.
- D. Submit written notification of damaged plants and structures.

3.03 INSTALLATION

- A. Provide templates or drawings for placement of inserts and anchors as required.
- B. Location: Install at locations as shown on Contract Drawings.
- C. Provide openings and other spaces as shown or required for contiguous work. Use materials and set to match surrounding work.
- D. Set precast concrete units in accordance with the Shop Drawings, complete with inserts, anchors, supports, fasteners, and other attachments to secure precast concrete units into place. Remove temporary shims, wedges, and spacers as soon as possible after anchoring and grouting are completed.

- E. Erect units plumb and true to line with uniform joints. Set with mortar as shown on the reviewed and accepted Shop Drawings. Use setting buttons to prevent extrusion of mortar.
- F. Rake out joints and point with grout. Tool joints as indicated in the Contract Documents.
- G. Remove and replace damaged or defective precast concrete units to match adjacent acceptable precast work.
- H. Field cut and finish precast units where required to maintain tolerances demonstrated in approved mock up, and per the Contract Documents.
- I. Precast concrete units shall relate to the adjacent proposed site conditions as shown in the Contract Drawings. Comply with the requirements specified in Section 033000 and Section 321560.

3.04 SEALING

- A. Meet requirements of manufacturer's current application instructions.

3.05 FIELD QUALITY CONTROL

- A. Field Observation Reviews by Construction Manager. Coordinate and schedule with Construction Manager.

3.06 PROTECTION

- A. Install hazard barricades and 3/4-inch, plywood covers to protect Work against damage defacement and staining during subsequent construction operation until Final Completion.

3.07 REPARING

- A. Repair exposed exterior surfaces of precast architectural concrete units to match color, texture, and uniformity of surrounding precast architectural concrete if permitted by the Construction Manager and Landscape Architect.
 - 1. Patching of chips in surface of precast architectural concrete units is allowable after Construction Manager and Landscape Architect approval under the following conditions:
 - a. Chips or dents no larger than 1 inch in length by 1 inch in width, and no larger than 1/2 inch in depth can be repaired/patched upon Construction Manager and Landscape Architect approval as per 3.07 A.
 - 2. Defects or damage consisting not considered repairable includes but is not limited to the following:

- a. Cracks.
 - b. Chips or dents larger than 1 inch by 1 inch in size.
 - c. Chips or dents larger than 1/2 inch in depth.
 - d. Any discoloring of architectural precast concrete units.
3. Defects or damage that are deemed not repairable by the Construction Manager and/or Landscape Architect must be replaced with new precast architectural concrete units at the Contractors expense.

3.08 CLEANING

- A. Comply with the requirements of Section 017423.
- B. Meet requirements of manufacturer's current printed instructions.
- C. Do not use cleaning materials or processes that could change the appearance of exposed concrete finishes.
- D. Clean and keep clean until Final Completion.

3.09 CONTRACT CLOSEOUT

- A. Provide in accordance with Section 017700.

END OF SECTION 034500

SECTION 050513 - SHOP APPLIED COATINGS FOR METAL

PART 1 - GENERAL

1.01 DESCRIPTION

- A. Provide powder coating as indicated and in compliance with Contract Documents.
 - 1. Section Includes:
 - a. Shop-applied Architectural Coatings for Aluminum Decorative Formed Metal Panels at Playground Shade Canopy
 - b. Shop-applied Architectural Coatings for Stainless Steel Retaining Wall Cladding

1.02 PAYMENT

- A. No separate payment shall be made for performing any Work required under this Section. All costs for Work required by this Section shall be included in the applicable lump sum(s), as set forth in Section 012901.

1.03 REFERENCES

- A. AAMA 2603 – Voluntary Specification, Performance Requirements and Test Procedures for Pigmented Organic Coatings on Aluminum Extrusions and Panels
- B. AAMA 2604 – Voluntary Specification, Performance Requirements and Test Procedures for High Performance Organic Coatings on Aluminum Extrusions and Panels
- C. AAMA 2605 - Voluntary Specification, Performance Requirements and Test Procedures for Superior Performing Organic Coatings on Aluminum Extrusions and Panels
- D. AAMA CW-10-15 - Care and Handling of Architectural Aluminum from Shop to Site
- E. ISO 12944 – Corrosion Protection of Steel Structures by protective paint systems
- F. ASTM B117 – Standard Practice for Operating Salt Spray (Fog) Apparatus
- G. ASTM G85 Annex A5 – Dilute Electrolyte Cyclic Fog/Dry Test
- H. ASTM D2244 - Standard Practice for Calculation of Color Tolerances and Color Differences from Instrumentally Measured Color Coordinates
- I. ASTM D2794 – Standard Test Method for Resistance of Organic Coating to the Effects of Rapid Deformation

- J. ASTM D4214 - Standard Test Methods for Evaluating the Degree of Chalking of Exterior Paint Films
- K. ASTM D7091 - Standard Practice for Nondestructive Measurement of Dry Film Thickness of Nonmagnetic Coatings Applied to Ferrous Metals and Nonmagnetic, Nonconductive Coatings Applied to Non-Ferrous Metals

1.04 RELATED SECTIONS

- A. General Conditions Article 4.7 – Shop Drawings and Other Submittals
- B. Section 012901 – Measurement and Payment
- C. Section 014300 – Quality Requirements
- D. Section 016100 – Control of Materials
- E. Section 017700 – Contract Closeout
- F. Requirements from the following section also apply to this Section
 - 1. Section 055001 – Site Metal Fabrications
 - 2. Section 057010 - Decorative Metal – Retaining Wall
 - 3. Section 057000 - Decorative Formed Metal
 - 4. Section 101400 – Signage
 - 5. Section 129300 – Site Furnishing

1.05 SUBMITTALS

- A. General: Submit in accordance with General Conditions Article 4.7.
- B. Submit submittals of this section simultaneously with submittals of sections with components with finishes specified in this Section.
 - 1. Product Data:
 - a. Product data for each coating.
 - b. Color Charts for finish indicating manufacturer’s colors available for selection.
 - c. Include sample of warranty customized for this Project.

- d. Samples for initial selection: Submit 1'x1' sample of each finish, color, and gloss level.
 - e. Samples for final selection: Submit 1'x1' sample of each finish, color, gloss level and substrate.
- C. Closeout Submittals: Submit following in accordance with Section 017700.
- D. List of final colors including manufacturers information.
- E. Cleaning and maintenance Data.
- F. Approved Applicator Guidelines.
- 1.06 QUALITY ASSURANCE
- A. Comply with the requirements specified in Section 014300.
 - B. Applicator Qualifications: Applicator must regularly engage in the application of shop-applied coating systems for projects of similar type to that specified. Applicator must also be equipped, trained, and approved for the application of the specified coating system and also be approved to provide a warranty as specified in this Section.
 - C. Manufacturer's Qualification: Coating Manufacturer must regularly engage, for at least 10 years in manufacturing shop-applied coating systems of similar type and for similar projects to that specified.
 - D. Follow all appropriate and applicable Society for Protective Coatings (SSPC) surface preparation standards for preparing metal substrates for coatings. Follow coatings supplier recommendations for designation of which SSPC standards must be followed for metal preparation for coating.
- 1.07 DELIVERY STORAGE AND HANDLING
- A. Comply with the requirements specified in Section 016100.
 - B. Deliver, store and handle coating system in accordance with manufacturer's instructions. Keep coatings in original, unopened packaging until time of application. Protect coating system to prevent contamination or damage.
 - C. Deliver, store, and handle coated parts in accordance with AAMA CW-10-15 Care and Handling of Architectural Aluminum from Shop to Site.
- 1.08 SEQUENCE AND SCHEDULING
- A. Sequence accessory installation with other work to minimize possibility of damage and soiling during remainder of construction period.

PART 2 - PRODUCTS

2.01 POWDER COATING

A. Products:

1. Custom - Comparable products of another manufacturer approved by Architect prior to bid.
2. Provide a shop applied powder coat system that adheres to the substrate of stainless steel or galvanized per the substrate material identified in the Contract Drawings, and that has the following requirements:
 - a. A stable system that provides a 10-year life.
 - b. Is non-fading.
 - c. Can include a protective clear coating to improve the life of the treatment.
 - d. Exterior rated.
 - e. Have high salt spray resistance.
3. The raw materials used in the manufacturing of the powder coating should provide uniform flow and finish, excellent weathering, and corrosion resistance in line with AAMA 2604.
4. The “Basis of Design” material shall be as detailed in Paragraph 2.03 A. High-Performance Super Durable Powder Finish.

2.02 APPLICATOR

- #### A. Shop applied application of the coating system by one of the following manufacturer’s approved applicators:
1. Tiger Drylac
 2. PPG Industrial Coatings
 3. IFS Coatings Inc
 4. TCI Powder Coatings
 5. Or approved equal
- #### B. Powder Coat Application.

1. Apply coatings in accordance with manufacturer's instructions.
2. All exposed metal surfaces shall be cleaned and prepared in accordance with the instructions of the powder coating manufacturer.
3. All cleaned surfaces shall receive two-coat powder coating system per 2.03A herein.

2.03 SHOP-APPLIED COATINGS FOR STEEL SHEET, PANELS AND TUBES

- A. High-Performance Super Durable Powder Finish: Two-coat powder coating system, including zinc rich powder primer followed by a Super Durable powder complying with AAMA 2604 and containing 100 percent Super Durable Polyester resin. Prepare, pretreat, and apply coating to exposed metal surfaces to comply with coating and resin manufacturers' written instructions.
 1. Color: RAL 1003 or as indicated in the Contract Documents.
 2. Retaining Wall Cladding: RAL 1003
 3. Decorative Formed Metal Cladding: See Contract Drawings

2.04 FINISHES

- A. Pretreatment, per manufacturer's recommendations, may include chromating and pre-anodizing for aluminum and zinc phosphating and blasting for stainless steel.
- B. Pretreat, using mechanical and chemical pretreatment methods according to coating manufacturer's requirements as well as requirements as detailed in where applicable.
 1. Surface treatment of stainless steel surfaces must be pickled and passivated prior to application of powder coat. Follow requirements as prescribed by powder coat manufacturer.
 2. Surface treatment of galvanized surfaces must be degassed at 5 degrees above cure temperature to minimize gassing. Surface to have a bead blast to provide adequate texture for adhesion of powder coat system. Follow requirements as prescribed by powder coat manufacturer.
- C. Powder Coat Application.
 1. Apply coatings in accordance with manufacturer's instructions.
 2. All exposed metal surfaces shall be cleaned and prepared in accordance with the instructions of the powder coating manufacturer.

3. All cleaned surfaces shall receive two-coat powder coating system per 2.03A herein.
 4. Application rate 3 mils to 4 mils.
 5. Each shipment of powder coating material shall be accompanied by a Certificate of Compliance.
 6. Do not use mixed coatings beyond pot life limits, do not add thinners to extend pot life.
 7. Use application equipment, tools, pressure settings, and techniques in accordance with manufacturers' instructions and good practices.
 8. Uniformly apply coatings at spreading rate required to achieve dry film thickness (DFT) per manufacturer's requirements.
 9. Apply coatings to be free of film characteristics or defects that would adversely affect performance or appearance of coatings systems.
 10. Field Repair:
 - a. Damaged Coatings: Touch-up repair damaged coatings. Touch-up of minor damage shall be acceptable where the result is not visibly different from adjacent surfaces. Recoat entire surface where touch-up is visibly different, either in sheen, texture, or color.
 - b. Coating Defects: Repair in accordance with manufacturer's instructions coatings that exhibit film characteristics or defects that would adversely affect performance or appearance of coating systems.
- D. Apply coatings as selected according to manufacturer's requirements.
- E. Shop-applied coating schedule.
- F. Finish: Matte

PART 3 - EXECUTION

3.01 PREPARATION

- A. Follow manufacturer's written recommendations for preparation of metal substrates to receive powder coating systems. Comply with applicable SSPC surface preparation standards.

3.02 APPLICATION

- A. Follow manufacturer’s written recommendations for application of powder coat systems.
- B. All metal items must receive proper surface preparation prior to application of powder coating.

3.03 INSTALLATION

- A. Refer to individual specification sections for installation requirements of items receiving shop-applied coatings.
- B. Patching and field touch-up protocols of damaged coatings of items receiving shop-applied coatings shall conform to 2.04 B10 herein, and as per manufacturer recommendations.

3.04 PROTECTION

- A. Remove plastic wrap from items that received shop-applied coatings at the time of installation.

3.05 CONTRACT CLOSEOUT

- A. Provide in accordance with Section 017700.

END OF SECTION 050513

NO TEXT ON THIS PAGE

SECTION 051200 - STRUCTURAL STEEL

PART 1 - GENERAL

1.01 DESCRIPTION

- A. The term "Structural Steel" is used as defined in accordance with the AISC Code of Standard Practice.
- B. Provide structural steel as specified and as shown on Contract Drawings and Contract Sections.

1.02 PAYMENT

- A. No separate payment shall be made for performing any Work required under this Section. All costs for Work required by this Section shall be included in the applicable lump sum(s), unit price(s), or allowance(s) as set forth in Section 012901.

1.03 REFERENCES

- A. American Institute of Steel Construction (AISC):
 - 1. 303: Code of Standard Practice for Steel Buildings and Bridges
 - 2. 325: Manual of Steel Construction, Fifteenth Edition
 - 3. 326: Structural Steel Detailing Manual
 - 4. 348: Specification for Structural Joints using ASTM A 325 or A 490 Bolts
 - 5. 360-5: Specification for Structural Steel Buildings
- B. ASTM International (ASTM):
 - 1. A6/A6M: Specification for General Requirements for Rolled Structural Steel Bars, Plates, Shapes, and Sheet Piling.
 - 2. A36/A36M: Specification for Carbon Structural Steel.
 - 3. A53: Standard Specification for Pipe, Steel, Black and Hot-Dipped, Zinc-Coated, Welded and Seamless.
 - 4. A108: Standard Specification for Steel Bars, Carbon and Alloy, Cold-Finished
 - 5. A123: Specification for Zinc (Hot-Dip Galvanized) Coatings on Iron and Steel Products.

6. A143: Practice for Safeguarding Against Embrittlement of Hot-Dip Galvanized Structural Steel Products and Procedures for Detecting Embrittlement.
 7. A153: Specification for Zinc Coating (Hot-Dip) on Iron and Steel Hardware.
 8. A194/A194M: Specification for Carbon and Alloy-Steel Nuts for Bolts for High-Pressure and High-Temperature Service.
 9. A307: Specification for Carbon Steel Bolts and Studs, 60,000 PSI Tensile Strength.
 10. A325: Specification for Structural Bolts, Steel, Heat Treated, 120/105 ksi Minimum Tensile Strength.
 11. A384: Practice for Safeguarding Against Warpage and Distortion During Hot-Dip Galvanizing of Steel Assemblies.
 12. A385: Practice for Providing High Quality Zinc Coatings (Hot-Dip).
 13. A449: Specification for Quenched and Tempered Steel Bolts and Studs.
 14. A500: Standard Specification for Steel for Cold-Formed Welded and Seamless Carbon Steel Structural Tubing in Rounds and Shapes.
 15. A563: Specification for Carbon and Alloy Steel Nuts.
 16. A572: Specification for High-Strength Low-Alloy Columbium-Vanadium Structural Steel.
 17. A780: Practice for Repair of Damaged and Uncoated Areas of Hot-Dip Galvanized Coatings.
 18. A992: Standard Specification for Steel for Structural Shapes for Use in Building Framing.
 19. B695: Standard Specification for Coatings of Zinc Mechanically Deposited on Iron and Steel.
 20. F436: Specification for Hardened Steel Washers.
 21. F1554: Standard Specification for Anchor Bolts, Steel, 36, 55, and 105 ksi Yield.
- C. American Welding Society (AWS):
1. A2.4 Standard symbols for welding, brazing, and non-destructive examination
 2. A3.0 Standard welding terms and definitions

3. A5.1 Specification for carbon steel electrodes for shielded metal arc welding
4. A5.18 Specification for carbon steel electrodes and rods for gas shielded arc welding
5. B1.10 Guide for the nondestructive examination of welds
6. B2.1 Specification for Welding Procedure and Performance Qualification
7. D1.1: Structural Welding Code – Steel

1.04 RELATED SECTIONS

- A. General Conditions Article 4.7 – Shop Drawings and Other Submittals
- B. Section 012901 – Measurement and Payment
- C. Section 014300 - Quality Requirements
- D. Section 016100 – Control of Materials
- E. Section 099110 – Shop Painting
- F. Section 353130 – Rolling Gates and Appurtenances
- G. Section 353131 – Swing Gates and Appurtenances

1.05 DESIGN CRITERIA

- A. Structural Connections: AISC Specification for Structural Steel Buildings. Design connections not fully detailed on the Drawings to resist the loads shown on the Contract Drawings or specified.
- B. Unless otherwise noted on Contract Drawings, design connections for ASTM A325 bolts, bearing-type connection with threads included in shear plane.
- C. Connections are to be designed by a Professional Engineer registered in the State of New-Jersey.

1.06 SUBMITTALS

- A. Submit the following shop drawings in accordance with General Conditions Article 4.7
- B. Submit in advance of fabrication complete information necessary for the fabrication of each component and part of the structural steel framing. Include the following:
 1. Member size and length (including beams and plates).

2. Bill of materials.
 3. Material specifications.
 4. Bolt hole size and bolt size.
 5. Cuts, copes, and bevels (including welding preparation requirements).
 6. Piece marks for field assembly.
 7. Detail of each connection or typical connection.
 8. Splices.
- B. Submit erection drawings showing complete information necessary for the erection of each component part of the structural steel framing. Include the following:
1. Dimensions for alignment and elevations of each member.
 2. Location of members and attachments by matchmarking of piece numbers.
 3. Type and location of each field connection.
 4. Number of shear connectors on each member.
 5. Detail of each field connection or typical connection.
 6. Anchor bolts and setting plans.
- C. Do not develop shop drawings by using reproductions of contract drawings. Identify each shop drawing detail by Contract Drawing detail title.
1. All drawings shall be certified by a Professional Engineer.
 2. Indicate both shop and field welding and the required nondestructive testing by welding symbols and nondestructive testing symbols as shown in the latest edition of AWS A2.4.
 - a. Fully explain special conditions with notes or details.
 - b. Welding symbols for groove welds shall indicate the groove depth required to obtain the specified effective throat thickness for the welding process and position of welding to be used.
 - c. The details of groove welds, joints, and preparation of base material shall be referenced to prequalified joints specified in AWS D1.1, Figures 3.2 through

3.11 and shall clearly distinguish between complete joint penetration and partial joint penetration.

- d. Fillet weld symbols shall indicate required weld size to obtain the specified effective throat thickness and effective length. For fillet weld lengths not specified provide a continuous weld.
3. Welding Procedures: Prepare written welding procedures for both shop and field welds, which are deemed prequalified in accordance with AWS D1.1 Code Section 3 and make the procedures available to the testing agency at the fabricator's plant. Prior to use of submit other for review procedures along with tests required to qualify the procedure in accordance with AWS D1.1 Code Section 3.2.3.
4. Submit sequence-of-welding outline.
5. Submittals for Evidence of Conformity to Specifications for each steel supplier: Certified mill test reports containing results of chemical and mechanical test as specified by ASTM A6 for the following material:
 - a. Structural steel shapes.
 - b. Structural steel bars.
 - c. Structural steel plates.

In addition to the certified mill test reports, the fabricator shall provide an affidavit stating that the structural steel furnished meets the requirements of ASTM specification for the grade furnished. Test any of the members not represented by certified mill test reports by the testing laboratory in accordance with ASTM specification for chemical and physical properties. The Contractor is responsible for the cost of sampling and testing.

6. Submit manufacturer's certification and test data that the following items furnished conform to the following specifications:
 - a. High-strength bolts including nuts and washers. Provide Connection type N per the AISC handbook unless otherwise noted in the drawings.
 - b. Shear Connectors: ASTM A108, stud base qualification requirements in accordance with AWS Code Section 7.6.
7. Proposed Substitutions: Submit for review in sketch form prior to submittal of shop drawings substitutions of members or modifications of details, if proposed by the Contractor. Submit in sketch form for review corrections for inaccuracy that result in a change from the structural drawing or final shop drawing details. Make such substitutions or corrections only when permitted by the Engineer.

8. Qualification test reports bearing witness certification by an independent testing laboratory for each welder, welding operator and tacker to be employed in the work.

1.07 QUALITY ASSURANCE

- A. Comply with the requirements specified in Section 014300.
- B. The Contractor has full responsibility for quality control and quality assurance during fabrication and assembly of all steel structures. The DEP may hire an independent testing firm to review fabrication practices and perform various non-destructive and destructive tests to determine compliance with the Contract Documents. The Contractor and its subcontractors and vendors shall give the independent testing firm full access and cooperation, in shop or field, to perform the testing.
- C. Provide structural steel in accordance with AISC Standard for Structural Steel Buildings and the Code of Standard Practice for Steel Buildings and Bridges, unless otherwise specified herein.
- D. Design connections not detailed on the Drawings shall be designed under direct supervision of a Professional Engineer experienced in design of this work and licensed in the State of New Jersey engaged by the Contractor or steel fabricator.
- E. Steel fabricator shall have five (5) years' experience minimum in structural steel fabrications.
- F. Steel erector shall have five (5) years' experience minimum in structural steel erection.
- G. Welding Qualification and Certification:
 1. Furnish written welding procedure for welds in conformance with the AWS D 1.1.
 2. Each welder, welding operator and tack welder shall be certified by test to perform type of work required in conformance with AWS D 1.1.
 3. If a welder or welding operator has not been engaged in a specific welding process for a period of six (6) months or more, that individual shall be deemed unqualified and shall not perform work on the project until the individual has been qualified again by testing in conformance with AWS D 1.1.
 4. Maintain duplicate qualification and certification records at the job site readily available for examination.
- H. Tolerances:
 1. Maintain tolerances conforming to AISC Code of Standard Practice.

2. Permissible variation tolerances conforming to ASTM A6.

I. Tension Calibrator:

1. Provide certification by an independent testing laboratory confirming the accuracy of the tension-measuring device when slip-critical connections and connections subject to direct tension are being used. Confirm accuracy not more than thirty (30) days prior to use on project and at intervals not more than six months thereafter.
2. Provide tension calibrator measuring device at the job site when high-strength bolts in slip-critical connections and connections subject to direct tension are being installed and tightened.
3. Conform to the AISC Specification for Structural Joints for frequency and of number confirmation tests to be performed and the test procedure.
4. Return tension calibrator measuring device to the independent testing laboratory for certification if Engineer questions its accuracy.
5. Tests and Inspections:
6. Weld Testing: In addition to visual inspection, all welds shall be tested and inspected, at a minimum, according to AWS D1.1/D1.1M and the inspection procedures listed in subparagraphs below. All deficiencies in Work that test reports and inspections indicate do not comply with the Contract Documents shall be corrected, and satisfactorily retested.
 - a. Liquid Penetrant Inspection: ASTM E 165. – 10 percent of Welds
 - b. Magnetic Particle Inspection: ASTM E 709; performed on root pass and on finished weld. Cracks or zones of incomplete fusion or penetration will not be accepted. – 10 percent of Welds
 - c. Radiographic Inspection: ASTM E 94; minimum quality level "2-2T." – 5 percent of Welds
 - d. Ultrasonic Inspection: ASTM E 164. – 5 percent of Welds

J. Supplemental Special Inspections and Testing:

1. The DEP may engage qualified special inspectors to perform oversight of the gate manufacturing, assembly, testing and inspections performed by the Contractor and its inspection and testing agency. The Contractor to provide testing agency access to the work as required.

1.08 DELIVERY, STORAGE AND HANDLING

- A. Comply with the requirements in Section 016100.
- B. Load structural members in such a manner that they may be transported and unloaded without being over-stressed, deformed or otherwise damaged.
- C. Protect structural steel members and packaged materials from corrosion and deterioration. Store material in a dry area.
- D. Adequately protect machined surfaces against rust and damage. Protection methods must be submitted for approval.
- E. Support materials stored outdoors above ground surfaces on wood runners and protected with acceptable effective and durable covers.
- F. Do not place materials on the structure in a manner that might cause distortion or damage to the members or the supporting structures. Repair or replace damaged materials or structures as recommended by the Construction Manager.

1.09 FIELD MEASUREMENTS

- A. Verify dimensions and make any field measurements necessary and be fully responsible for accuracy and layout of the work according to Contract Documents requirements.
- B. Review the Contract Drawings and report any discrepancies to the Engineer for clarification prior to starting fabrication.

PART 2 - PRODUCTS

2.01 STRUCTURAL STEEL

- A. Gates to comply with material requirements in gate Sections 353130 and 353131.
- B. W shapes in conformance with ASTM A992 unless otherwise indicated or specified.
- C. Steel, Sheet and Strip, Carbon, Hot-rolled, Structural Quality: ASTM A570/A570M.
- D. Structural Pipe: ASTM A53, Grade B.
- E. C, M, S and HP shapes in conformance with ASTM A572, Grade 50, unless otherwise specified or shown on Contract Drawings.
- F. Angles, plates and bars in conformance with ASTM A36.

- G. Round, square and rectangular structural tube members (HSS) in conformance with ASTM A500, Grade B.
- H. Steel pipe in conformance with ASTM A53, Grade B.
- I. Hot-Dip Galvanized Carbon Steel in conformance with ASTM A123.
- J. Shear studs in conformance with ASTM A449.

2.02 FASTENERS

- A. Comply with material requirements in gate Sections 353130 and 353131.
- B. Carbon Steel Bolts, Nuts and Washers: ASTM A307, Grade A.
- C. High-strength fasteners in conformance with ASTM A325, Type 1.
- D. Nuts and washers ASTM A563 and F 436.
- E. Hot-dip Galvanized Bolts, nuts and washers in conformance with ASTM A153.
- F. Mechanically Galvanized Bolts, nuts and washers in conformance with ASTM B695.
- G. ASTM A276 Type 304 Stainless steel

2.03 ANCHOR BOLTS

- A. Steel anchor bolts in conformance with ASTM F1554, grade 36.
- B. Embedded Anchors: ASTM A325.
- C. Semi-embedded Anchors: ASTM A276 Type 304 Stainless steel.

2.04 WELDED STUDS

- A. Weld studs in conformance with the requirements of ASTM A108, Grade 1015 or 1020.

2.05 WELDING

- A. All welding shall meet the requirements of AWS D1.1.
- B. All welding on gates shall be done in the fabricator's shop. The pre-authorization of the Construction Manager is required for field welding.
- C. All fabricator and field welders must be certified by the American Welding Society according to AWS D1.1.

- D. Provide equipment for welding, electrodes, welding wire and fluxes capable of producing indicated welds when used by certified welders under AWS welding procedures. Provide welding materials that comply with requirements of AWS Structural Welding Code.
 - E. The plates to be welded shall be carefully cut to the right dimensions. The dimensions and shape of the edges to be joined shall be such as to permit better melting and complete penetration.
 - F. No welding shall be performed when the base metal temperature is below 50°F. In this case, all surfaces within 3" of the welding point should be preheated in accordance with AWS D1.1 and maintained at this temperature for the rest of the operation. Temperature should be measured with temperature-indicating sticks or other means accepted by the Construction Manager.
 - G. High frequency hammering of welds is not allowed.
 - H. Arc priming onto the pieces is prohibited.
 - I. All major welds joining primary elements of the structure shall be continuous. Whenever possible, the welds shall be completed before assembly and welding of the secondary elements. Otherwise, clearances shall be provided in the secondary elements to allow continuity of the main welds.
 - J. All welded assemblies shall be completed and sealed.
 - K. Any projection or weld spatter shall be removed.
 - L. On each side of the weld joint, a 2-inch-wide strip should be cleaned to remove rust, grease and burrs.
 - M. Welded structural parts subjected to alternating stresses or whose surfaces are machined for precision alignment shall be stress relieved prior to machining. The method of stress relieving treatment shall be specified on drawings submitted to the Construction Manager. The stress relief procedure shall be submitted for approval by the Construction Manager.
 - N. In addition to the one hundred (100%) percent visual inspection of all welded joints, the Contractor shall perform, at its expense, all X-ray, ultrasonic, magnetic particles and dye penetrant inspections as specified by AWS D1.1.
- 2.06 SHOP FABRICATION
- A. Fabricate each element and connection as indicated on the fabrication shop drawings accepted by the Engineer. Fabricate and shop assemble work to the greatest extent practical in conformance with following publications:

1. AISC Manual of Steel Construction
2. AISC Specification for Structural Joints
3. AISC Detailing Manual
4. AWS Structural Welding Code

2.07 CONNECTIONS

- A. Connect members with ASTM A325 high strength bolts unless otherwise specified or shown on Contract Drawings. Provide clean-cut holes without torn or ragged edges and remove outside burrs.
- B. Provide high strength bolted construction assembly in accordance with AISC Specifications for Structural Joints. Bolted parts shall fit solidly together when assembled and shall not be separated by gaskets or any other interposed compressible material. Free joint surfaces burrs and foreign materials. Score hot-dipped galvanized contact surfaces with a wire brush or blasted prior to assembly. Grinding of surfaces is not permitted. If the thickness of the material is not greater than the normal diameter of the bolt plus 1/8 inch, the holes may be punched. If the thickness of the material is greater than the normal diameter of the bolt plus 1/8 inch, drill it full size or subpunched 1/16 inch smaller than the bolt diameter and reamed to full size. Provide holes for work to be secured to structural steel framing and for the passage of work through steel framing members. Provide threaded nuts, threaded units, or other items welded to framing, which receive other work. Provide normal bolt hole diameters not more than 1/16 inch in excess of the normal bolt diameter unless otherwise specified in contract drawings. Provide required slotted or oversize bolt holes as specified in the AISC Specification for Structural Joints Section 3.3. Tighten each bolt to provide the minimum tension shown in Table 8.1 of AISC Specification for Structural Joints for the size and grade of bolts used. Tighten bolts in accordance with the manufacturer's specifications.
- C. Framed beam shear connections, end plate (shop welded), single angle or double angle header connections (shop bolted or welded) or shear tabs:
 1. Frames beam shear connections shall not be less than one half of the depth of the connected member.
 2. Spandrel beams, provide full depth web connection or top and bottom flange clips where detailed and shown on Contract Drawings.
 3. Bolted connections shall be bearing type unless noted otherwise on the Contract Drawings.
- D. Provide full cross section bearing on milled ends of columns, crane rails, monorails, and bearing stiffeners.

E. Welded Connections:

1. Weld connections indicated or specified.

F. Make connections with ASTM A307 carbon steel bolts when specified or as shown in Contract Drawings.

G. Provide anchor rods with washer and heavy hex nuts. Provide hot-dip galvanized anchor rods, washers and heavy hex nuts with galvanized steel.

2.08 MACHINING

A. The machining shall be carried out using a machine with an up-to-date certificate of calibration.

B. All machined parts shall comply with the surface finish and tolerances appropriate to the use. Surface finish and tolerances shall be shown on shop drawings used in manufacturing.

C. All machined parts shall be dimensionally inspected. Non-conforming parts shall be corrected in a manner acceptable to the Construction Manager or replaced with new parts accepted by the Construction Manager.

D. All machined parts shall be checked using suitable and calibrated measuring instruments.

E. Centerings, tolerances and surface finishes shall comply with the requirements on the production drawings.

F. All press fit parts shall be rechecked before final assembly.

G. Inspection of the machined surfaces using the machine that was used to machine it is not acceptable.

2.09 SHOP PAINTING

A. Comply with the requirements in Section 099110.

B. Apply shop prime coat to structural steel, except to members or portions of members to be embedded in concrete or masonry, surfaces and edges to be field welded, galvanized surfaces and machined surfaces, unless otherwise specified.

C. Provide surface preparation as required by the manufacturer for the specified coating system.

D. Immediately after surface preparation, apply primer as specified in Section 099110. Use painting methods that will result in full coverage of joints, corners, edges, and exposed surfaces.

- E. Structural steel encased in masonry, or which will be inaccessible in the finished work, receive two shop coats of primer.

2.10 GALVANIZED

- A. Provide hot-dip galvanizing in conformance with ASTM A123, Grade 100 to steel indicated or specified to be galvanized coated.
- B. Provide hot-dip galvanizing, in conformance with ASTM A153, to bolts, nuts and washers that will be used with galvanized steel.
- C. Complete fabrication and prepare surfaces of steel by removing weld spatter, flux, residue, burrs and metal surface defects before galvanizing. Clean weldments with power wire brush prior to galvanizing.
- D. Provide steel dipped into solution of zinc chloride plus ammonium chloride immediately prior to galvanizing.
- E. Tap bolt nuts after hot-dip galvanizing in conformance with ASTM A563.
- F. Inspect galvanized material for compliance with the Contract Sections. Mark the material with a clearly visible stamp indicating the name of the galvanizer, the ASTM number and the weight of zinc coating in ounces per sq. ft.

2.11 GALVANIZED TOUCH-UP

- A. Galvanized Touch-Up: Where galvanizing is damaged, touch-up abraded areas, using brushed-on method, with zinc-rich coating. Touch-up repair with zinc-rich coating of not less than 3 mil and not more than 6 mil dry film thickness.
- B. Touch-up damaged galvanized surfaces with one of the following zinc rich coatings:
 1. Endupor, zinc-rich coating by Dampney Manufacturing Co., Everett, MA
 2. ZiRP, zinc-rich coating by Duncan Galvanizing Corp., Everett, MA
 3. ZRC Cold Galvanizing Compound or ZRC Galvilite by ZRC Worldwide, Division of Norfolk Corp., Marshfield, MA;
 4. Or approved equal.

PART 3 - EXECUTION

3.01 ERECTION OF STRUCTURAL STEEL

- A. Conform to the referenced AISC standards. Brace and secure work until permanent connections are completed. Provide accessories and fasteners to secure the work in place whether or not shown or specified. Comply with OSHA requirements.
- B. Erect structural steel with qualified, experienced personnel. Plan and lay out steel to require minimum of cutting. Erect work plumb, square, and true to line and level and in precise positions. Provide temporary bracing and guys to counteract loads and stresses to which structure may be subjected, including those due to erection equipment and its operation. Do not encumber premises with material or equipment.
- C. Splice members only where shown or specified. On exposed welded connections, remove erection bolts, fill holes with plug welds, and grind smooth at exposed surfaces. Comply with AISC specifications for bearing, adequacy of temporary connections, alignment, and the removal of paint on surfaces adjacent to field welds. Do not enlarge holes in members by burning or the use of drift pins, except in secondary bracing members. Ream holes that must be enlarged to place bolts. Do not use gas-cutting torches in the field for correcting fabrication errors in the structural framing.
- D. Erect, plumb, level, and align each individual member within the tolerance defined in Section 7 and Commentary of the AISC Code of Standard Practice, allowing for weld shrinkage during erection for assurance that the end product is within specified tolerance. Establish and maintain the building line for use in plumbing the exterior columns.

3.02 DAMAGED MEMBERS

- A. During erection, straighten or replace members that are bent, twisted, or damaged. If heating is required in straightening, perform heating by methods that ensure uniform temperature throughout entire member. When required by the Engineer, remove members that are impaired strength and replace with new members at no additional cost to DEP.

3.03 MISFITS AT BOLTED CONNECTIONS

- A. Immediately notify the Engineer where misfits in erection bolting are encountered. The Submit a method to remedy the misfit for review by the Engineer. The Engineer will determine whether the remedy is acceptable or if the member must be refabricated.
- B. Do not enlarge incorrectly sized or misaligned holes in members by burning or by the use of drift pins. Notify the Engineer immediately and submit a proposed method of remedy for review by the Engineer.

3.04 ANCHOR BOLTS

- A. Install anchor bolts by using templates, setting drawings, and instructions provided by the fabricator. Verify positions of bolts prior to delivery of steel; report errors or deviation for adjustment. After anchor bolts have been embedded, protect threads by applying grease and by having the nuts screwed on until the metalwork is installed.

3.05 COLUMN BASEPLATES AND BEARING PLATES

- A. Set columns with base plates attached and bearing plates for beams and similar structural members to their proper alignment and elevation using shim packs. Set loose column bases level to their proper alignment and elevation by use of shim packs or as shown in the contract drawings. Tighten anchor bolts after members have been positioned and plumbed. Do not remove protruding wedges, shims, or other leveling devices but cut off flush with the baseplate prior to packing with grout.

3.06 CONNECTIONS

- A. Securely bolt members to maintain steel in position during field welding and final bolting and accommodate dead loads, wind, and erection stresses.
- B. Tighten high strength bolted connections in accordance with AISC Specification for Structural Joints using ASTM A325 or A490 Bolts and manufacturer's specifications.
- C. Perform shop-welded construction in accordance with AWS D1.1 Sections 2 through 6, whichever is applicable. Use only welded joints deemed as being prequalified in accordance with AWS Code Section 4, which are selected from AWS Code Figures 3.2 through 3.11.
- D. Common Bolts: Tighten ASTM A307 and nonslip critical bolts to snug tight plus one-quarter turn with upset bolt threads to preclude loosening or use self-locking nuts.
- E. Do not reuse galvanized high-strength bolts, nuts and washers.

3.07 CLEAN-UP

- A. Upon completion of the work, remove surplus materials, rubbish, and debris resulting from the operations, including disused equipment and implements of service, and leave the entire structure and site, insofar as the work of this Section is concerned, in a neat, clean condition.

3.08 FIELD QUALITY CONTROL

- A. Inspection and testing, by the DEP, is not intended to relieve Contractor of responsibility. Defective material or workmanship, if found at any time prior to final acceptance of work, shall be rejected regardless of previous inspection.

3.09 CONTRACT CLOSEOUT

- A. Provide in accordance with Section 017700.

END OF SECTION 051200

SECTION 055000 - MISCELLANEOUS METAL

PART 1 - GENERAL

1.01 DESCRIPTION

- A. This Section includes metal fabrications not specifically included in other Sections and required for completion of work as shown on Contract Drawings and in accordance with Contract Documents.
- B. Furnish labor, materials, equipment and incidentals necessary to install the products specified.

1.02 PAYMENT

- A. No separate payment shall be made for performing any Work required under this Section. All costs for Work required by this Section shall be included in the applicable lump sum(s), unit price(s), or allowance(s) as set forth in Section 012901.

1.03 REFERENCES

- A. American Society of Mechanical Engineers (ASME):
 - 1. B18.5: Round Head Bolts.
- B. ASTM International (ASTM)
 - 1. A6: General Requirements for Rolled Structural Steel Bars, Plates, Shapes and Sheet Piling.
 - 2. A36: Standard Specification for Carbon Structural Steel.
 - 3. A48: Standard Specification for Gray Iron Castings.
 - 4. A53: Standard Specification for Pipe, Steel, Black and Hot-Dipped, Zinc-Coated, Welded and Seamless.
 - 5. A108: Standard Specification for Steel Bars, Carbon, Cold Finished, Standard Quality.
 - 6. A123/A123M: Standard Specification for Zinc (Hot-Dip Galvanized) Coatings on Iron and Steel Products.
 - 7. A153: Standard Specification for Zinc Coating (Hot-Dip) on Iron and Steel Hardware.

8. A240: Standard Specification for heat-resisting chromium and chromium-nickel stainless steel plate, sheet, and strip for pressure vessels.
9. A276: Standard Specification for Stainless Steel Bars and Shapes.
10. A307: Carbon Steel Bolts and Studs, 60,000 psi Tensile Strength.
11. A325: Structural Bolts, Steel, Heat Treated 120/105 ksi Minimum Tensile Strength.
12. A366: Standard Specification for Steel, Sheet, Carbon, Cold-Rolled, Commercial Quality.
13. A489: Standard Specification for Carbon Steel Lifting Eyes.
14. A500: Standard Specification for Cold-Formed Welded and Seamless Carbon Steel Structural Tubing in Rounds and Shapes.
15. A501: Standard Specification for Hot-Formed Welded and Seamless Carbon Steel Structural Tubing.
16. A502: Steel Structural Rivets.
17. A536: Standard Specification for Ductile Iron Castings.
18. A569: Steel, Carbon (0.15 Maximum, Percent) Hot-Rolled Sheet and Strip Commercial Quality.
19. A570: Steel, Sheet and Strip, Carbon, Hot-Rolled, Structural Quality.
20. A572: Standard Specification for High-Strength Low-Alloy Columbium-Vanadium Structural Steel
21. A576: Steel Bars, Carbon, Hot-Wrought, Special Quality.
22. A675: Steel Bars, Carbon, Hot-Wrought, Special Quality, Mechanical Properties.
23. A786: Rolled Steel Floor Plates.
24. A992: Standard Specification for Structural Shapes.
25. B26: Specification for Aluminum-Alloy Sand Castings.
26. B211: Specification for Aluminum-Alloy Bars, Rods, Profiles and Tubes.
27. B209: Specification for Aluminum and Aluminum-Alloy Sheet and Plate.

28. B221: Specification for Aluminum-Alloy Extruded Bars, Rods, Wire, Shapes, and Tubes.
 29. B247: Specification for Aluminum and Aluminum-Alloy Die Forgings, Hand Forgings and Rolled Ring Forgings.
 30. B308: Standard Specification for Aluminum-Alloy 6061-T6 Standard Structural Profiles.
 31. B 429: Specification for Aluminum-Alloy Extruded Structural Pipe and Tube.
 32. D1056: Standard Specification for Flexible Cellular Materials—Sponge or Expanded Rubber.
 33. F436: Standard Specification for Hardened Steel Washers.
 34. F468: Standard Specification for Nonferrous Bolts, Hex Cap Screws, Socket Head Cap Screws, and Studs for General Use.
 35. F541: Standard Specification for Alloy Steel Eyebolts.
 36. F593: Standard Specification for Stainless Steel Bolts, Hex Cap Screws, and Studs.
 37. F594: Standard Specification for Stainless Steel Nuts.
 38. F844: Standard Specification for Washers, Steel, Plain (Flat), Unhardened for General Use.
 39. F1554: Standard Specification of Anchor Bolts, steel, 36, 55 and 105-ksi Yield Strength.
 40. F2329: Standard Specification for Zinc Coating, Hot-Dip, Requirements for Application to Carbon and Alloy Steel Bolts, Screws, Washers, Nuts, and Special Threaded Fasteners.
- C. American Institute of Steel Construction (AISC):
1. ANSI/AISC 360-5: Specification for Structural Steel Buildings
 2. AISC Manual of Steel Construction, Thirteenth Edition
- D. American Welding Society (AWS):
1. A2.4: Standard Symbols for Welding, Brazing, and Nondestructive Examination.
 2. D1.1: Structural Welding Code.

3. D1.2: Structural Welding Code - Aluminum.
- E. National Association of Architectural Metal Manufacturers (NAAMM):
1. MBG 531: Metal Bar Grating Manual.
 2. MBG 532: Heavy Duty Metal Bar Grating Manual.
 3. MBG 533: Welding Specifications for Fabrication of Steel, Aluminum and Stainless Bar Grating.
- F. Aluminum Association:
1. Aluminum Design Manual – Specifications and Guidelines for Aluminum Structures.
 - a. AA M31C22A41
 - (1) M31: Mechanical Finish, Fine Satin
 - (2) C22: Finish, Medium Matte
 - (3) A41: Clear Anodic Coating, Class I
- G. Submit the following shop drawings in accordance with General Conditions Article 4.7.
- H. Submit shop drawings and product data showing materials of construction and details of installation for all items furnished under this Section. Shop drawings shall show sizes of members, method of assembly, anchorage and connection to other members.
1. Test Reports:
 - a. Submit certified copies of mill test reports on each steel, stainless steel, or aluminum proposed for use showing the physical properties and chemical analysis.
 2. Product Data:
 - a. Manufacturer’s catalog sheets on pre-manufactured items.
 3. Miscellaneous Submittals:
 - a. Provide International Conference of Building Officials (ICBO) or other similar building code organization recommendations regarding safe allowable design loads for concrete anchors.
 4. Signed and sealed by Professional Engineer registered in the State of New Jersey.

1.04 RELATED SECTIONS

- A. General Conditions Article 4.7 – Shop Drawings and Other Submittals
- B. Section 012901 – Measurement and Payment.
- C. Section 014300 - Quality Requirements.
- D. Section 016100 - Control of Materials.
- E. Section 017700 - Contract Closeout.
- F. Section 051200 – Structural Steel.
- G. Section 099110 - Shop Painting.
- H. Section 353130 – Rolling Gates and Appurtenances
- I. Section 353131 – Swing Gates and Appurtenances
- J. Section 353132 – Stop Logs and Appurtenances

1.05 DESIGN CRITERIA

- A. Where beam end reactions are not shown, design the connection for one-half the total allowable uniform load in kips for beams laterally supported at the given span, as determined by the tables for allowable loads on beams in the AISC Manual of Steel Construction, in addition to any axial loads identified on the Contract Drawings.
- B. Rolling Gate design requirements are specified in Section 353130
- C. Swing Gate design requirements are specified in Section 353131
- D. Stop Logs design requirements are specified in Section 353132

1.06 QUALITY ASSURANCE

- A. Comply with the requirements specified in Section 014300.
- B. The connections that are not detailed on the Contract Drawings shall be designed under direct supervision of a Professional Engineer experienced in design of this work and licensed in the State of New Jersey.
- C. Steel:
 - 1. Comply with Section 051200.

2. Conform to codes for arc and gas welding in building construction of AWS and to AISC Specifications. Surfaces to be welded shall be free from loose scale, rust, grease, paint, and other foreign material, except mill scale that will withstand vigorous wire brushing may remain.
3. Qualify welding operators in accordance with AWS D1.1. Qualification tests shall be run by a recognized testing laboratory acceptable to the Construction Manager at Contractor's expense.

D. Aluminum:

1. Weld with gas metal arc (GMA) or gas tungsten arc (GTA) processes in accordance with AWS D1.2.

E. Adhesive Anchors:

1. All adhesive anchor products shall be supplied from a renowned manufacturer in the industry and approved by Construction Manager.
2. Adhesive Anchor Installers shall be trained and certified by manufacturer.

F. Galvanized Coating:

1. Company specializing in hot-dip galvanizing after fabrication and following procedures of Quality Assurance Manual of the American Galvanizers Association.

1.07 DELIVERY, STORAGE AND HANDLING

- A. Comply with the requirements specified in Section 016100.
- B. Insofar as practical, factory assemble items specified herein. Package, ship and tag unassembled materials in a manner that will protect materials from damage and will facilitate identification and field assembly.
- C. Package stainless steel items in a manner to provide protection from carbon impregnation.
- D. Protect painted coatings and hot-dip galvanized finishes from damage due to metal banding and rough handling. Use padded slings and straps.
- E. Deliver items to be incorporated into the work of other trades in sufficient time to be checked prior to installation.
- F. Store fabricated items in a dry area, not in direct contact with ground.

1.08 FIELD MEASUREMENTS

- A. The Contractor shall verify all dimensions and shall make any field measurements necessary and shall be fully responsible for accuracy and layout of the work.
- B. The Contractor shall review the Contract Drawings and any discrepancies shall be reported to the Construction Manager for clarification prior to starting fabrication.

PART 2 - PRODUCTS

2.01 MISCELLANEOUS METAL SHAPES, CASTINGS, BOLTS AND ACCESSORIES

A. Structural Steel Shapes:

- 1. W Shapes: ASTM A992, 50 ksi
- 2. M Shapes: ASTM A572 Grade 50
- 3. S, C and MC Shapes: ASTM A572 Grade 50
- 4. L Shapes: ASTM A36
- 5. HP Shapes: ASTM A572 Grade 50
- 6. HSS Square and Rectangular Shapes: ASTM A500, Grade B, 46 ksi
- 7. HSS Round Shapes: ASTM A500, Grade B, 42 ksi
- 8. Pipe Shapes: ASTM A53, Grade B, 35 ksi
- 9. Plates and Bars: ASTM A36
- 10. Steel Sheets: ASTM A366

B. Stainless Steel Shapes:

- 1. Exterior and Submerged Uses: AISI, Type 316
- 2. Industrial Uses: AISI, Type 316
- 3. For Welding: AISI, Type 304L, Type 316L
- 4. Shapes and Bars: ASTM A276
- 5. Plate, Sheet and Strip: ASTM A240

C. Aluminum Shapes:

- | | | |
|----|--|--------------------------|
| 1. | Structural Shapes | ASTM B308, Alloy 6061-T6 |
| 2. | Extruded Pipe | ASTM B429, Alloy 6063-T6 |
| 3. | Aluminum Sheet and Plate | ASTM B209, Alloy 6061-T6 |
| D. | High Strength Bolts for Steel Members | ASTM A325 |
| C. | Steel Washers | ASTM F436 |
| D. | Plain Unhardened Steel Washers: | ASTM F844 |
| E. | Anchor Bolts: ASTM F1554, Grade 36 standard headed bolts with heavy hex nuts, Grade A washers, hot-dip galvanized, unless otherwise specified. | |
| F. | Stainless Steel Bolts and Nuts: F593 and F594, AISI Type 316 | |
| G. | Connection Bolts for Wood Members: ASTM A307, galvanized where specified | |
| H. | Iron Castings: ASTM A48, Class 35 | |
| I. | Galvanizing: ASTM A123, Zn w/0.5 percent minimum Ni. | |
| J. | Galvanizing, hardware: ASTM A153, Zn w/0.5 percent minimum Ni. | |
- 2.02 POST INSTALLED ANCHORS
- A. Mechanical Expansion Type Anchors: Anchors shall be qualified per ICC-ES AC193.
 - 1. Use stainless steel unless otherwise noted.
 - 2. Do not use expansion anchors in submerged and dynamic load applications.
 - B. Drop-In Anchors: Anchors shall be qualified per ICC-ES AC01.
 - 1. Use stainless steel unless otherwise noted.
 - 2. Do not use drop-in anchors in corrosive or humid areas or when subjected to dynamic loads.
 - C. Sleeve Anchors: Anchors shall be qualified per ICC-ES AC01
 - 1. Use stainless steel unless otherwise noted.
 - D. Undercut Anchors:
 - 1. Use stainless steel unless otherwise noted.

2. Under cut anchors are not acceptable for use in submerged applications.

E. Adhesive Anchors:

1. Adhesive anchors shall be Stainless Steel Type 316 or hot-dipped galvanized.
2. Epoxy adhesive shall be ANSI/NSF approved for use in contact with potable water.

2.03 ANCHOR CHANNEL INSERTS

- A. Make anchor channels from channel profiles with “I” anchors shop welded to back of channels. Furnish anchor channels with head bolts, channels, nuts for a complete installation. Material shall be Stainless Steel Type 316.

2.04 EYE BOLTS

- A. Provide eyebolts of the welded-eye or forged type, hot-dipped galvanized steel per ASTM F2329 Type 316 Stainless Steel.
- B. Provide threaded carbon steel lifting eyes that comply with ASTM A489, Type 1 or 2, Style B.
- C. Provide threaded alloy steel eyebolts that comply with ASTM F541 and ASME B18.5, Type 1 or 2, long or short length.

2.05 GRATING SUPPORT ANGLES AND FRAMING

- A. Provide galvanized steel stainless steel support angles embedded in concrete. Angles shall be 1/4-inch thick, inside depth of support angle shall equal depth of bearing bar, inside length of support angle leg shall equal depth of grating, but not less than 1-1/4 inch. Provide 1 inch by 1/4-inch by 8 inches long bent anchor bars or 3/8-inch diameter by 6 inch headed anchor studs welded to backs of angles at 18 inches on center.

2.06 METAL FRAMES

- A. Provide door, hatch, and grille frames, and other frames fabricated from structural shapes.
- B. Fabricate frames from rolled steel sections or rolled steel sections and steel plates. Select sections for trueness of web and flange. Straighten members so finished frames are uniform, square, and true throughout length and depth of assembled units.
- C. Connect built-up members of frames by plug welding. Miter or cope and join members with continuous welding beads. Provide temporary spreader bars to prevent springing frames out of shape prior to and during erection.

2.07 STRAP ANCHORS AND STUD ANCHORS

- A. Provide anchors for frames, curbs, sills, and other metal fabrications anchored into concrete or masonry. Fabricate anchors from strap iron, bent to shape, or of weldable studs, welded to backs of members. Where size and spacing not noted, provide 1 inch by 1/4-inch strap anchors or 3/4-inch diameter studs for concrete and 1-1/2 inch by 1/8-inch strap anchors for masonry. Space masonry anchors to fit jointing of adjacent masonry work at 4 feet on center. Space concrete anchors at 3 feet on center.
- B. Where anchors and plates or clips are to be built in for attachment of later Work, provide bolts in plates or clips, welded to back, with threaded ends extended.
- C. For attaching Work to masonry or concrete where anchors or inserts cannot be built in, provide concrete anchors or machine bolts and screws.

2.08 STEEL BOLLARDS

- A. Galvanized steel pipe bollards shall be fabricated to dimensions and details shown in Contract Drawings. Fabricated bollards from 8 inch nominal outside diameter pipe.

2.09 FABRICATION

- A. Connections and Workmanship:
 - 1. Fabricate details and connection assemblies in accordance with Contract Drawings and Specifications, with projecting corners clipped and filler pieces welded flush.
 - 2. Fit work together in fabrication shop and deliver complete or in parts, ready to be set in-place or assembled in field.
 - 3. Provide work true to detail, with clean, straight, sharply defined profiles and smooth surfaces of uniform color and texture free from defects impairing strength or durability.
 - 4. Provide clips, lugs, brackets, straps, plates, bolts, nuts, washers, and similar items, as required for fabrication and erection.
 - 5. Provide castings of uniform quality, free from blowholes, porosity, hard spots, shrinkage distortion. They shall be smooth and well cleaned by shot blasting.
 - 6. Welding:
 - a. Comply with applicable items of Section 051200, Art.2.05.

- b. Provide rigid and continuous welds or spot welded as specified and as shown on Contract Drawing. Dress the face of welds flush and smooth. Close fit exposed joints and locate where least conspicuous.
 - c. Weld aluminum work on the unexposed side when possible in order to prevent pitting or discoloration.
 - d. Weld aluminum in compliance with the latest edition of AWS D1.2. Support and clamp component parts of built-up members in proper position for welding.
 - e. Weld shop connections and bolt or field weld connections, unless otherwise specified.
 - f. Grind exposed edges of welds to 1/8-inch minimum radius. Grind burrs, jagged edges, and surface defects smooth.
 - g. Prepare welds and adjacent areas so there is:
 - (1) No undercutting or reverse ridges on weld bead.
 - (2) No weld spatter on or adjacent to weld or other area to be painted or coated.
 - (3) No sharp peaks or ridges along weld bead.
 - h. In addition to the 100 percent visual inspection of all welded joints, the Contractor shall perform, at its expense, all X-ray, ultrasonic, magnetic particles and dye penetrant inspections required by AWS D1.2.
7. Bolting:
- a. Use bolts of lengths required so bolts can be full nut but do not project more than 1/4-inch beyond face of nut. Do not use washers unless specified. Provide hexagonal head bolts with hexagonal nuts.
 - b. Provide holes required for connection of adjacent or adjoining work wherever noted on Drawings. Locate holes for bolting equipment to supports to tolerance of +/- 1/16-inch of dimensions indicated.
 - c. Required tightening torque shall be shown on drawings for mechanical assembly.

B. Machining:

1. The machining shall be carried out using a machine with an up-to-date certificate of calibration.
2. All machined parts shall comply with the surface finish and tolerances appropriate to the use. Surface finish and tolerances shall be shown on shop drawings used in manufacturing.
3. All machined parts shall be dimensionally inspected. Non-conforming parts shall be corrected in a manner acceptable to the Construction Manager or replaced with new parts accepted by the Construction Manager.
4. All machined parts shall be checked using suitable and calibrated measuring instruments.
5. Centerings, tolerances and surface finishes shall comply with the requirements on the production drawings.
6. All press fit parts shall be rechecked before final assembly.
7. Inspection of the machined surfaces using the machine that was used to machine it is not acceptable.

C. Galvanizing:

1. Galvanize after fabrication by hot-dipped process conforming with ASTM A123.
2. Ship and handle in manner to avoid damage to zinc coating.

D. Shop Painting:

1. Do not paint or coat ferrous metal surfaces embedded in concrete.
2. Comply with Section 099110.

PART 3 - EXECUTION

3.01 EXAMINATION

- A. Upon receipt of material at job site, inspect all materials for shipping damage. Replace damaged items at no cost to the DEP.
- B. Examine supports for size, layout, and alignment.
- C. Correct defects considered detrimental to proper installation.

3.02 INSTALLATION

- A. Provide items such as bolts, shims, blocks, nuts, washers, and wedging pieces to complete installation.
- B. Erect to lines and levels, plumb and true, and in correct relation to adjoining Work. Secure parts using concealed connections when practicable.
- C. Plumb and true vertical members to tolerance of +/- 1/8 inch in 10 feet. Level horizontal members to tolerance of +/- 1/8 inch in 10 feet.
- D. Use steel bolts to connect structural steel members. Use stainless steel bolts to connect structural aluminum members.
- E. Anchor Bolts and Concrete Anchors:
 - 1. Preset anchor bolts using templates. Do not use concrete anchors in place of anchor bolts.
 - 2. After anchor bolts are embedded, protect projecting threads by applying grease and having the nuts installed until the time of installation of equipment or metalwork.
 - 3. Do not install concrete anchors until concrete has reached specified minimum compressive strength.
 - 4. Install concrete anchors in accordance with anchor manufacturer recommendation. Embedment depth of anchor shall be as recommended by the anchor manufacturer, but not less than as shown on Contract Drawings.
 - 5. Locate concrete anchors to clear reinforcing bars in concrete.
 - 6. Adhesive anchors shall be installed following manufacturer requirements.
- F. Weld headed anchor studs in accordance with manufacturer's recommendations.
- G. Do not place new holes or enlarge unfair holes by use of cutting torch.

3.03 PAINTING, REPAIR, AND PROTECTION

- A. Paint aluminum in contact with concrete in accordance with Section 099110. Under no circumstances shall aluminum contact dissimilar metal.
- B. Between aluminum grating, aluminum stair treads, or aluminum handrail brackets and steel supports, insert 1/4-inch thick neoprene isolator pads, 85 +/- 5 Shore A durometer, sized for full width and length of bracket or support.
- C. Apply an anti-seize compound on all stainless steel fasteners to prevent galling.

- D. Field painting repair in compliance with Section 099110.
- E. Field repair of damaged galvanized coatings:
 - 1. Clean and repair Zinc coating that has been burned by welding, abraded, or otherwise damaged after installation. Clean damage area by wire brushing and removing all traces of welding flux and loose or cracked zinc coating
 - 2. Coat surfaces using zinc-rich paint.
- F. Field repair of damaged primer.
 - 1. Touch up abrasions in the shop primer immediately after erection. Paint areas left unprimed for welding with primer after welding.

3.04 CONTRACT CLOSEOUT

- A. Provide in accordance with Section 017700.

END OF SECTION 055000

SECTION 055001 – SITE METAL FABRICATIONS

PART 1 - GENERAL

1.01 DESCRIPTION

- A. Provide site metal fabrications as indicated and in compliance with Contract Documents. Exterior finish carpentry elements are a delegated design item as per Paragraph 1.05 B herein and Section 329300.
 - 1. Bench Type 1
 - 2. Barstool Seating
 - 3. Plaza Planters with Wood Seat Tops
 - 4. Entry Signage
 - 5. Amphitheater Wood Top Seating
 - 6. Metal Retaining Walls – Wall Type 2
- B. This Section is in addition to requirements found in Section 055000.

1.02 PAYMENT

- A. No separate payment shall be made for performing any Work required under this Section. All costs for Work required by this Section shall be included in the applicable Cove Park lump sum(s), as set forth in Section 012901.

1.03 REFERENCES

- A. Americans with Disabilities Act (ADA)
- B. American Society for Testing and Materials (ASTM International):

1.04 RELATED SECTIONS

- A. General Conditions Article 4.7 – Shop Drawings and other Submittals
- B. Section 012901 – Measurement and Payment

- C. Section 014300 – Quality Requirements
- D. Section 017700 – Contract Closeout
- E. Section 050513 – Shop Applied Coatings For Metal
- F. Section 055000 – Miscellaneous Metals
- G. Section 062013 – Exterior Finish Carpentry
- H. Section 323900 – Manufactured Site Specialties

1.05 REQUIREMENTS

- A. Provide all fabrications (or listed elements) are under the requirements of a coordinated fabrication as outlined under Section 329200. All design and fabrication to be fully coordinated during review, fabrication, assembly and installation.
- B. Contractor Design: All work associated with elements in this Section is to be performed as a delegated design and build. Contractor is to provide final design, engineering, fabrication.
 - 1. General: Design and engineering of bench type 1, barstool seating, plaza planters with wood seat tops, entry signage, amphitheater wood top seating, and metal retaining wall type 2 elements to be developed in accordance with building codes for structural loads and capacities.
 - 2. Contractor to provide all calculations and analysis necessary to complete the Work.
 - 3. Contractor is to coordinate work of others associated with or attached to features in this Section including but not limited to:
 - a. Precast architectural concrete stairs.
 - b. Retaining walls.
 - c. Cast in place concrete pathways.
 - d. Resin bound aggregate paving.
 - e. Unit pavers.
 - f. Planting.
 - g. Artificial Turf.

- h. Decking.
 - i. Resist Structure.
 - j. LED Lighting.
- C. Furnish all transportation, labor, materials and equipment to perform the following: Furnish and install features in this Section and accessories necessary to complete the Work.

1.06 SUBMITTALS

- A. Submit the follow shop drawings in accordance with General Conditions Article 4.7.
- B. Shop drawings: Prepare project specific information, drawn accurately to scale. Submit large scale dimensioned drawings, showing detail fabrication and installation of each element indicated in the drawings. Indicate locations, plans, elevations, dimensions, shapes, and cross sections. Do not base Shop Drawings on reproductions of the Contract Documents or standard printed data. Shop Drawings are to be coordinated with all relevant, related and adjacent components, in accordance with Section 323900.
 - 1. Preparation: Fully illustrate requirements in the Contract Documents. Include the following information, as applicable:
 - a. Identification of all products used in fabrication(s).
 - b. Indicate jointing, reveals, patterns, and extent and location of each surface finishes.
 - c. Schedules of parts, fabrication pieces, hardware, anchors, fasteners and finishes.
 - d. Indicate welded connections by AWS standard symbols. Indicate net weld lengths. Include details of welding materials, equipment, sequence and technique to be used.
 - e. Indicate locations, tolerances, and details of anchorage devices to be embedded in or attached to structure or other construction.
 - f. Compliance with specified standards and codes.
 - g. Notations of coordination requirements and sequencing of work.
 - h. Field verification and notation of dimensions based established upon actual field conditions and adjacent structures. Where items must fit and coordinate

- with finished surfaces and/or constructed spaces, take measurements at the site and not from drawings.
- i. Relationship and attachment to adjoining construction clearly indicated.
 - j. Fully fabricated unit(s). Drawings to show work by multiple trades in a single drawing set to assure coordination of work.
 - k. Seal and signature of a professional engineer if specified. Structural drawings and calculations prepared and signed by a licensed engineer registered in the State of New Jersey.
 - l. Provide templates to field locate fasteners and inserts to install elements.
- C. Shop drawings shall be fully coordinated with all conditions, showing adjacent work, and be combined into one package in accordance with Section 323900 to provide:
1. 1/4" = 1'-0" for all elevation and plans views for metal work items showing layout and conditions of the site. The drawings will provide field confirmation of conditions of the site.
 2. 1" = 1'-0" larger elevation views of all metal work locations.
 3. 1 1/2" = 1'-0" and 3" = 1'-0" for all details depicting fasteners, connections, and small fabrication elements.
- D. Samples: Materials specified herein shall be submitted for approval, and approvals obtained before materials are delivered to the site.
1. Samples to be provided for approval include:
 - a. Plaza Planter cladding colors and finish samples per colors and finishes identified on the Contract Drawings and in conformance with the requirements of shop applied coatings for metal per Section 050513.
 - b. Plaza Planter wood seat top module with perforated metal and steel frame sample. Provide a full planter seat top module with full coordination of wood slats per Section 062013. Provide one sample of each planter seat module type per the Contract Drawings, including but not limited to seating slats typical, seating slats at small radius, and seating slats at lounge.
 - c. Bench Type 1 framing tubular steel including finish and color samples for both straight and radial framing stainless steel elements, and in all tube sizes used in bench construction.

- d. Barstool Seating framing tubular steel including finish and color samples for both straight and radial framing stainless steel elements, and in all tube sizes used in bar stool construction.
2. Samples to be provided in coordination with information, samples and mockups included in Section 323900 and Section 062013.
- E. Product Data: Manufacturer’s descriptive data fully describing each product to be included in the fabrication and painting of metal work.
- F. Calculations: Structural calculations for all steel fabricated items with related hardware, shall be submitted for review and evaluation by the Architect/Engineer, and shall be signed and sealed by a Professional Engineer registered in the State of New Jersey.

1.07 QUALITY ASSURANCE

- A. Comply with the requirements of Section 014300.
- B. Fabricator and Installer Qualifications: Firm experienced in successfully producing metal fabrications similar to that indicated for this Project, with sufficient production capacity to produce required units without causing delay in the work.
- C. Welding Qualifications: Qualify welding processes and welding operators in accordance with the following:
 1. AWS D1.1/D1.1M, “Structural Welding Code-Steel”.
 2. AWS D1.6/D1.6M, “Structural Welding Code-Stainless Steel”.
 3. Certify that each welder has satisfactorily passed AWS qualification test for welding processes involved.
- D. Reference Standards
 1. Comply with National Association of Architectural Metal Manufacturers (NAAMM) “Metal Finishes Manual” for application and designation of finishes.
 2. Manufacturer’s specifications and recommendations.
- E. Fabrication quality shall be minimum NAAMM Class 1 finish.
- F. All stainless-steel materials are to be pickled and passivated prior to painting.
- G. All metal finishes shall be in accordance with NAAMM/NOMMA Metal Finishes Manual.

H. Mockups:

1. Provide as per Section 323900.

PART 2 - PRODUCTS

2.01 METALS FOR FABRICATIONS

A. All metals used in the fabrications of landscape metal pieces shall be in conformance with following material types:

1. Stainless Steel Sheet, Strip, and Plate: ASTM A240/A240M or ASTM A666, Type 316L.
2. Plate and Sheet: ASTM A480, Stretcher level sheets.
3. Bar Stock and Shapes: ASTM A276/A276M Type 316L.
4. Tubing: Stock and Shapes: ASTM A276/A276M Type 316L.
5. Pipe: ASTM A312/A312M, Grade TP 316L.

2.02 FASTENERS

A. General:

1. Fasteners for Anchoring to Other Construction: unless otherwise indicated, select fasteners of type, grade, and class required to produce connections suitable for anchoring indicating items to other types of construction indicated.
2. Provide 316L stainless steel fasteners and associated connections.
3. All exposed fasteners to public access shall be tamper resistant.
4. All fasteners shall be architectural finish quality with concealed or flush heads, or rounded edges and caps if specifically noted or approved.
5. Provide provisions in the connections for dissimilar materials to prevent corrosion. Include gaskets, sealers or coatings.

B. Bolts and Nuts: Countersunk and flush or button head fasteners with binding bolts, ASTM A307, Grade A, ASTM A563, and flat washers.

C. Machine Screws: ANSI B18.6.3.

- D. Plant Washers: Round, ANSI B18.22.1.
- E. Lock Washers: Helical, spring type, ANSI B18.21.1.
- F. Expansion Anchors: Anchor bolt and sleeve assembly with the capability to sustain, without failure, a load equal to 6 times the load imposed when installed in unit masonry and equal to 4 times the load imposed when installed in concrete, determined in accordance with ASTM E448.

2.03 NON-SHRINK GROUT

- A. Premixed, nonmetallic, non-corrosive product, complying with ASTM C1107, Class B or C, at flowable consistency for 30 minutes for temperature extremes of 45 deg F to 90 deg F.
 - 1. Products:
 - a. Masterflow 555, Master Builders
 - b. Five Star Grout, U.S. Grout Corp
 - c. Sika Corporation
 - d. Or approved equal

2.04 FABRICATION GENERAL

- A. Workmanship:
 - 1. Use materials of size and thickness indicated or required to produce strength and durability in finished product for use intended.
 - 2. Work to dimensions indicated.
 - 3. Form exposed work true to line and level with accurate angles and surfaces and straight, sharp edges.
 - 4. Ease exposed edges to a radius of approximately 1/32-inch, unless otherwise indicated.
 - 5. Form bent-metal corners to smallest radius possible without causing grain separation or otherwise impairing work.

6. Weld corners and seams continuously, complying with AWS recommendations. At exposed connections, grind exposed welds smooth and flush to match and blend with adjoin surfaces. Welds shall be imperceptible in the finished work.
7. Form exposed connections with hairline joints, flush and smooth, using concealed fasteners wherever possible. Use hex head countersunk screws or bolts for exposed fasteners. All exposed fasteners to public access to be tamper resistant security screws.
8. Cut, reinforce, drill and tap miscellaneous metal work as indicated to receive finish hardware and similar items.

2.05 FABRICATION ELEMENTS

A. Schedule of Fabricated Elements:

Fabricated Element	Refer to Contract Documents:	Finish and Color
Bench Type 1 (Delegated Design Item)		
Stainless Steel frame and mounting elements in configuration and sizes as shown on Contract Documents.	CPL013, CPL940	Refer to Furnishings Schedule, CPL013
Barstool Seating (Delegated Design Item)		
Stainless Steel frame and mounting elements in configuration and sizes as shown on Contract Documents.	CPL013, CPL941	Refer to Furnishings Schedule, CPL013
Plaza Planter with Wood Seat Tops (Delegated Design Item)		
Large Plaza Planter: Stainless Steel fins, cladding, angles, perimeter frame for seat modules, perforated metal plate for seat modules, W-piles, and mounting elements in configuration and sizes as shown on Contract Documents.	CPL013, CPL930, CPL931, CPL932, CPL934.1, CPL934.2, CPL934.3, CPS405	Refer to Furnishings Schedule, CPL013
Small Plaza Planter Type A & B: Stainless Steel fins, cladding, angles, perimeter frame for seat modules, perforated metal plate for seat modules, W-piles, and mounting elements in configuration and sizes as shown on Contract Documents.	CPL013, CPL930, CPL933, CPL934.1, CPL934.2, CPL934.3, CPS405	Refer to Furnishings Schedule, CPL013

Amphitheater Wood Top Seating (Delegated Design Item)		
Stainless Steel perimeter frame for seat modules, perforated metal plate for seat modules, and mounting elements in configuration and sizes as shown on Contract Documents.	CPL918.1, CPL918.2	Stainless Steel 316L No. 4 Finish
Wall Type 2A & 2B – Metal Retaining Wall (Delegated Design Item)		
Stainless Steel metal edge plate, skate stop, W-piles, angles, and mounting elements in configurations and sizes as shown on Contract Documents.	CPL010, CPL935, CPL937.1, CPL937.2, CPL937.3, CPL937.4, CPS602, CPS603	Refer to Materials Schedule, CPL010
Entry Signage (Delegated Design Item)		
Stainless Steel base plate, top plate, threaded rods, and mounting elements in configuration and sizes as shown on Contract Documents.	CPL980, CPL981, CPL982, CPL983	Stainless Steel, 316L No. 4 Finish

PART 3 - EXECUTION

3.01 FABRICATION

- A. Fabrication shall be according to AISC and NAAMM Standards. Form metal work to required shapes and sizes, with true lines, curves, and angles. Ease all sharp edges. Provide necessary rebates, lugs, and brackets for assembly and installation. Mill joints to tight hairline fit, cope or miter corners.
- B. Welding: By certified welders using A.W.S. Standards. Welding electrodes and filler metal shall match type and alloy of metal to be welded. All welds must be continuous. Clean, dress and grind smooth all exposed welds.
- C. Anchors and Inserts: Furnish as required for installation.

3.02 SURFACE PREPARATION

- A. General:

1. Dislodge dirt, rust, mortar spatter and other dry materials by scraping or brushing. Remove dust and loose material by brushing, sweeping, vacuuming or blowing with high-pressure air.
 2. Remove oil, wax and grease by scraping off heavy deposits and cleaning with mineral spirits or a hot trisodium phosphate solution followed by a water rinse.
 3. Verify that surfaces to be coated are dry, clean and free of dust, dirt, oil, waste, grease or other contaminants.
 4. All stainless-steel pieces shall be in conformance with ASTM A380, Type 316L.
 5. All stainless-steel materials are to be pickled and passivated prior to painting.
- B. Prepare all metals identified for painting shall be cleaned, primed and painted in accordance with the requirements of paint manufacturer, for exterior painting treatments. All pieces are to be shop painted and delivered to the site for installation. Field painting is not allowed. For painted items, refer to Section 050513.

3.03 INSTALLATION

- A. Provide anchors and fasteners to secure items to in-place construction as required.
- B. Set items in accurate locations, aligned, plumbed, and level. Repair or replace damaged items as directed.
- C. Fit exposed connections accurately together to form tight, hairline joints or where indicated, with uniform reveals and spaces for sealant and joint filers.
- D. Where cutting, welding, and grinding are required for proper shop fitting and jointing of ornamental metal items, restore finishes to eliminate any evidence of such corrective work. Passivate all stainless-steel welds.
- E. Do not cut or abrade finishes that cannot be completely restored in the field. Return items with such finishes to the shop for required alterations, followed by complete refinishing or provide new units as required.
- F. Restore damaged protective coverings after installation. Maintain until other work in same areas is completed. Remove protective coverings and clean exposed surfaces prior to final inspection.

3.04 CLEANING

- A. Provide as per Section 323900.

3.05 COORDINATION WITH RELATED DISCIPLINES

- A. The Contractor shall coordinate the locations of penetrations, reinforcement required for landscape metalwork scope items including, but not limited to, base plates, sleeves, anchors, fasteners, hardware, etc., with the requirements of all related disciplines.
 - 1. Review structural drawings which correspond to landscape drawings at each structural concrete penetration to determine reinforcing locations relative to landscape metalwork anchors and coordinate those locations in the field to avoid conflicts.
- B. The Contractor shall coordinate the work of their own sub-contractors with specialty contractors.

3.05 CONTRACT CLOSEOUT

- A. Provide in accordance with Section 017700.

END OF SECTION 055001

NO TEXT ON THIS PAGE

SECTION 057010 - DECORATIVE METAL - RETAINING WALL CLADDING

PART 1 - GENERAL

1.01 SUMMARY

A. Section Includes:

1. Photolithographic Bead-Blasted Stainless Steel Retaining Wall Cladding and Doors: Including framing, stiffeners, bracing, support, attachment assembly and all accessories required to hang the stainless steel panel sheet to the Retaining Wall structure.
2. Powder Coated Stainless Steel, RAL 1003, Retaining Wall Cladding

1.02 PAYMENT

- ##### A.
- No separate payment shall be made for performing any Work required under this Section. All costs for Work required by this Section shall be included in the applicable Cove Park lump sum(s), as set forth in Section 012901.

1.03 RELATED SECTIONS

- ##### A.
- General Conditions Article 4.7 – Shop Drawings and Other Submittals
- ##### B.
- Section 012901 – Measurement and Payment
- ##### C.
- Section 014300 - Quality Requirements
- ##### D.
- Section 016100 – Control of Materials
- ##### E.
- Section 017700 – Contract Closeout
- ##### F.
- Requirements from the following section also apply to this Section
1. Section 050513 - Shop Applied Coatings for Metal
 2. Section 057500 – Decorative Formed Metal
 3. Section 079200 – Joint Sealants

1.04 COORDINATION

- ##### A.
- Coordinate installation of anchorages for decorative metal items. Furnish setting drawings, templates, and directions for installing anchorages, including sleeves, concrete

inserts, anchor bolts, and items with integral anchors, that are to be embedded in concrete or masonry. Deliver such items to Project site in time for installation.

1.05 PREINSTALLATION MEETINGS

- A. Preinstallation Conference: Conduct conference at Project site.

1.06 SUBMITTALS

- A. Submit the following shop drawings and product samples in accordance with General Conditions Article 4.7.
- B. Product Data: For each type of product, including finishing materials. Submit samples no less than 1' x 1' of decorative stainless steel face material in finish specified.
- C. Shop Drawings: Show fabrication and installation details for decorative metal.
 - 1. Include plans, elevations, sections, jointing, component details, and attachment details.
 - 2. Indicate materials and profiles of each decorative metal member, fittings, joinery, finishes, fasteners, anchorages, and accessory items.
- D. Samples for Initial Selection: For products involving selection of color, texture finish, or design.
- E. Samples for Verification: For each type of exposed finish.
 - 1. Sections of linear shapes.
 - 2. Full-size Samples of castings and forgings.
 - a. For custom castings, submit finished Samples showing ability to reproduce detail, and quality of finish.
 - 3. Samples of welded and brazed joints showing quality of workmanship and color matching of materials.
- F. Qualification Data: For installer, fabricator, colored and textured stainless steel finisher.
- G. Mill Certificates: Signed by manufacturers of stainless-steel certifying that products furnished comply with requirements.
- H. Welding certificates.

1.07 QUALITY ASSURANCE

- A. Comply with the requirements of Section 014300.

- B. Manufacturer Qualifications
 - 1. Minimum 10 years experience in the manufacture of stainless steel sheet goods and fabricated products.
 - 2. Provide reference list of at least 10 public space projects currently using decorative stainless steel facing materials produced by the manufacturer in the finish specified.
 - 3. Member, United States Green Building Council (USGBC).
- C. Fabricator Qualifications: A firm experienced in producing decorative metal similar to that indicated for this Project and with a record of successful in-service performance, as well as sufficient production capacity to produce required units.
- D. Installer Qualifications: Fabricator of products.
- E. Organic-Coating Applicator Qualifications: A firm experienced in successfully applying organic coatings, of type indicated, to aluminum extrusions and employing competent control personnel to conduct continuing, effective quality-control program to ensure compliance with requirements.
- F. Powder-Coating Applicator Qualifications: A firm experienced in successfully applying powder coatings of type indicated and employing competent control personnel to conduct continuing, effective quality-control program to ensure compliance with requirements.
- G. Welding Qualifications: Qualify procedures and personnel according to the following:
 - 1. AWS D1.6/D1.6M, "Structural Welding Code - Stainless Steel."
- H. Mockups: Build mockups to verify selections made under Sample submittals, to demonstrate aesthetic effects, and to set quality standards for fabrication and installation.
 - 1. Build mockups as shown in Drawings and constructed per approved Shop Drawings for the following types of decorative metal with full size components and panel including supports, bracing, attachments, stiffeners, assembly, suspension system and accessories:
 - a. Retaining Wall Cladding.
 - 2. Approval of mockups does not constitute approval of deviations from the Contract Documents contained in mockups unless Architect specifically approves such deviations in writing.
 - 3. Subject to compliance with requirements, approved mockups may become part of the completed Work if undisturbed at time of Substantial Completion.

1.08 DELIVERY, STORAGE, AND HANDLING

- A. Comply with the requirements of Section 016100
- B. Store decorative metal in a well-ventilated area, away from uncured concrete and masonry, and protected from weather, moisture, soiling, abrasion, extreme temperatures, and humidity.
- C. Deliver and store cast-metal products in wooden crates surrounded by enough packing material to ensure that products are not cracked or otherwise damaged.
- D. Deliver material to installation site in manufacturer's original packaging. Store in a flat, horizontal position. Protect material against abrasion and impacts. Do not stack other materials or equipment on top of stainless steel sheets.
- E. Handle sheets carefully to avoid kinking.
- F. When practical, leave strippable films in place until installation is completed.

1.09 FIELD CONDITIONS

- A. Field Measurements: Verify actual locations of walls and other construction contiguous with decorative metal by field measurements before fabrication and indicate measurements on Shop Drawings.

PART 2 - PRODUCTS

2.01 DECORATIVE METAL PANEL AND DOOR FABRICATORS AND INSTALLERS

- A. Acceptable Manufacturer
 - 1. Provide Stainless Steel finish by Forms + Surface, Rimex Metals, Zahner, or approved equal.
- B. Fabricator and Installer: Subject to compliance with requirements, provide decorative stainless steel metal work by one of the following:
 - 1. Bamco Inc., 30 Baekeland Avenue, Middlesex, NJ 08846.
 - 2. Hi Tech Metals, 59-20 56th Avenue, Maspeth, NY 11378.
 - 3. Altona Custom Metal, 23 N Washington Ave., Little Ferry, NJ 07643.
 - 4. Or approved equal.

2.02 METALS, GENERAL

- A. Metal Surfaces, General: Use materials with smooth, flat surfaces unless otherwise indicated. Use materials without seam marks, roller marks, rolled trade names, stains, discolorations, or blemishes.

2.03 STAINLESS STEEL

- A. Material: Stainless Steel
 - 1. Finish: Seastone
 - 2. Pattern: Scatter. Refer to drawings for pattern gradient.
 - 3. Treatment: Provide Ceramiloc™ treatment, an invisible, protective treatment that significantly increases the fingerprint resistance and maintenance ease of stainless steel. Patented technology molecularly bonds nano-silica particles to the surface of stainless steel.
- B. Tubing: ASTM A 554, Grade MT 316L.
- C. Sheet, Strip, Plate, and Flat Bar: ASTM A 666, Type 316L.
- D. Bars and Shapes: ASTM A 276, Type 316L.
- E. Wire Rope and Fittings

2.04 FASTENERS

- A. Fastener Materials: Unless otherwise indicated, provide the following:
 - 1. Stainless-Steel Items: Type 316L stainless-steel fasteners.
 - 2. Dissimilar Metals: Type 316L stainless-steel fasteners.
- B. Fasteners for Anchoring to Other Construction: Unless otherwise indicated, select fasteners of type, grade, and class required to produce connections suitable for anchoring indicated items to other types of construction indicated.
- C. Provide concealed fasteners for interconnecting components and for attaching decorative metal items to other work unless exposed fasteners are unavoidable.
 - 1. Provide tamper-resistant recessed machine screws for exposed fasteners unless otherwise indicated.
- D. Post-Installed Anchors: Fastener systems with an evaluation report acceptable to authorities having jurisdiction, based on ICC-ES AC193.

1. Material for Exterior Locations and Where Stainless Steel Is Indicated: Alloy Group 2 (A4) stainless-steel bolts, ASTM F 593 (ASTM F 738M), and nuts, ASTM F 594 (ASTM F 836M).

2.05 MISCELLANEOUS MATERIALS

- A. Low-Emitting Paints and Coatings: Paints and coatings applied to decorative metal items shall comply with the testing and product requirements of the New Jersey Department of Environmental Protection Division of Air Quality, Regulatory Development, New Jersey Administrative Code Title 7, Chapter 27, 27A and 27B.
- B. Shop Primers: Provide primers that comply with manufacturer's recommendation and requirement.
- C. Universal Shop Primer for Ferrous Metal: Fast-curing, lead- and chromate-free, universal modified-alkyd primer complying with MPI#79 and compatible with topcoat.
 1. Use primer containing pigments that make it easily distinguishable from zinc-rich primer.
- D. Epoxy Zinc-Rich Primer: Complying with MPI#20 and compatible with topcoat.
- E. Shop Primer for Galvanized Steel: Comply with manufacturer's recommendation and requirement.
- F. Laminating Adhesive: Adhesive recommended by metal fabricator that will fully bond metal to metal, will prevent telegraphing and oil-canning, and is compatible with substrate and noncombustible after curing.

2.06 FABRICATION, GENERAL

- A. Assemble items in the shop to greatest extent possible to minimize field splicing and assembly. Disassemble units only as necessary for shipping and handling limitations. Clearly mark units for reassembly and coordinated installation. Use connections that maintain structural value of joined pieces.
- B. Form decorative metal to required shapes and sizes, true to line and level with true curves and accurate angles and surfaces. Finish exposed surfaces to smooth, sharp, well-defined lines and arris.
- C. Form bent-metal corners to smallest radius possible without causing grain separation or otherwise impairing the Work.
- D. Form simple and compound curves in bars, pipe, tubing, and extruded shapes by bending members in jigs to produce uniform curvature for each configuration required; maintain cross section of member throughout entire bend without buckling, twisting, cracking, or otherwise deforming exposed surfaces.

- E. Cut, drill, and punch metals cleanly and accurately. Remove burrs and ease edges to a radius of approximately 1/32 inch (1 mm) unless otherwise indicated. Remove sharp or rough areas on exposed surfaces.
 - F. Mill joints to a tight, hairline fit. Cope or miter corner joints. Fabricate connections that will be exposed to weather in a manner to exclude water.
 - G. Provide weep holes where water may accumulate. Locate weep holes in inconspicuous locations.
 - H. Provide necessary rebates, lugs, and brackets to assemble units and to attach to other work. Cut, reinforce, drill, and tap as needed to receive finish hardware, screws, and similar items unless otherwise indicated.
 - I. Comply with AWS for recommended practices in shop welding and brazing. Weld and braze behind finished surfaces without distorting or discoloring exposed side. Clean exposed welded and braze] joints of flux, and dress exposed and contact surfaces.
 - 1. Where welding and brazing cannot be concealed behind finished surfaces, finish joints to comply with NOMMA's "Voluntary Joint Finish Standards" for Type 1 Welds: no evidence of a welded joint.
 - J. Provide castings that are sound and free of warp, cracks, blowholes, or other defects that impair strength or appearance. Grind, wire brush, sandblast, and buff castings to remove seams, gate marks, casting flash, and other casting marks.
- 2.07 STAINLESS STEEL WITH ECO-ETCH SCATTER PATTERN ON RETAINING WALL CLADDING ANDBI-FOLDING DOORS
- A. Fabricate retaining wall cladding, door and bi-folding doors from Stainless-Steel sheet of 11 gage (1/8” minimum) thickness, size, and pattern indicated.
 - 1. Drawings indicate metal patterns required and are based on products of one manufacturer, “ECO-ETCH” patterns on “Seastone” stainless steel by Forms and Surfaces, Pittsburgh, PA 15223. Similar product produced by other manufacturers may be considered, provided deviations are minor and do not change design concept as judged solely by Architect/Engineer.
 - 2. On the Gradient Image Artwork stainless steel wall cladding with bi-folding doors, the final Artwork to be provided by the Architect.
 - 3. All folding edges and corner shall be back cut to produce sharp edge.
 - B. Fabricate mounting frames for decorative metal from extruded stainless-steel zee-clips, tubes and angles of profiles and to sizes and shapes indicated. Miter frame members at corners and connect with concealed splice plates welded to back of frames.

1. Drawings indicate mounting frame profiles required and are based on products of one manufacturer. Similar mounting frame profiles produced by other manufacturers may be considered, provided deviations are minor and do not change design concept as judged solely by Architect.
- C. Stud-Welding: Interconnect mounting frame with stud-welds and bolt to zee clip connector plates unless otherwise indicated. Use welding method that is appropriate for bead blast stainless steel and textured finish indicated that develops full strength of members joined and will not cause heat draw, or deformation on the exposed stainless steel finish textured surfaces. Finish exposed surfaces smooth, flush and blended to match adjoining surfaces.
- D. Provide all accessories for the Bi-Folding doors and single door:
 1. Continuous hinge.
 2. Concealed hinge.
 3. 3-point locking system.
 4. Free rolling roller-wheels.

2.08 POWDER COATED STAINELSS STEEL RETAINING WALL CLADDING

- A. Fabricate retaining wall cladding color stainless-steel sheet of 9 gauge minimum thickness, size, and pattern indicated.
 1. RAL 1003.
 2. All folding edges and corner shall be back cut to produce sharp edge.
- B. Fabricate mounting frames for colored metal from extruded stainless-steel zee-clips, tubes and angles of profiles and to sizes and shapes indicated. Miter frame members at corners and connect with concealed splice plates welded to back of frames.
 1. Drawings indicate mounting frame profiles required and are based on products of one manufacturer. Similar mounting frame profiles produced by other manufacturers may be considered, provided deviations are minor and do not change design concept as judged solely by Architect.
- C. Stud-Welding: Interconnect mounting frame with stud-welds and bolt to zee-clip connector plates unless otherwise indicated. Use welding method that is appropriate for color stainless steel finish indicated that develops full strength of members joined and will not cause heat draw, or deformation on the exposed stainless steel finish-surfaces. Finish exposed welds and surfaces smooth, flush, and blended to match adjoining surfaces.

D. Provide all accessories for the Bi-Folding doors in stainless steel:

1. Continuous hinge.
2. Concealed hinge.
3. 3-point locking system.
4. Free rolling roller-wheels.

2.09 FINISHES, GENERAL

- A. Comply with NAAMM's "Metal Finishes Manual for Architectural and Metal Products" for recommendations for applying and designating finishes.
- B. Protect mechanical finishes on exposed surfaces from damage by applying a strippable, temporary protective covering before shipping.

2.10 STAINLESS-STEEL FINISHES

- A. Surface Preparation: Remove tool and die marks and stretch lines, or blend into finish.
- B. Polished Finishes: Grind and polish surfaces to produce uniform finish, free of cross scratches.
 1. Run grain of directional finishes with long dimension of each piece.
- C. Bright, Cold-Rolled, Unpolished Finish: No. 2B.
- D. Directional Satin Finish: No. 4.
- E. Dull Satin Finish: No. 6.
- F. Reflective, Directional Polish: No. 7.
- G. Mirrorlike Reflective, Nondirectional Polish: No. 8.
- H. When polishing is completed, passivate and rinse surfaces. Remove embedded foreign matter and leave surfaces chemically clean.
- I. Sputter-Coated Finish: Titanium nitride coating deposited by magnetic sputter-coating process over indicated mechanical finish.
- J. Colored, Oxide-Film Finish: Clear, oxide interference film produced by degreasing and then immersing in a mixture of chromic and sulfuric acids.
 1. Product: Subject to compliance with requirements, provide INCO colored stainless-steel finish as developed and licensed by International Nickel Co., Ltd.

2. Color: Match Architect's color sample.

PART 3 - EXECUTION

3.01 EXAMINATION

- A. Examine substrates and conditions, with Installer present, for compliance with requirements for installation tolerances and other conditions affecting performance of decorative metal.
- B. Proceed with installation only after unsatisfactory conditions have been corrected.

3.02 INSTALLATION, GENERAL

- A. Provide anchorage devices and fasteners where needed to secure decorative metal to in-place construction.
- B. Perform cutting, drilling, and fitting required to install decorative metal. Set products accurately in location, alignment, and elevation, measured from established lines and levels. Provide temporary bracing or anchors in formwork for items to be built into concrete, masonry, or similar construction.
- C. Fit exposed connections accurately together to form tight, hairline joints or, where indicated, uniform reveals and spaces for sealants and joint fillers. Where cutting, welding, and grinding are required for proper shop fitting and jointing of decorative metal, restore finishes to eliminate evidence of such corrective work.
- D. Do not cut or abrade finishes that cannot be completely restored in the field. Return items with such finishes to the shop for required alterations, followed by complete refinishing, or provide new units as required.
- E. Install concealed gaskets, joint fillers, insulation, and flashings as work progresses.
- F. Restore protective coverings that have been damaged during shipment or installation. Remove protective coverings only when there is no possibility of damage from other work yet to be performed at same location.
 1. Retain protective coverings intact; remove coverings simultaneously from similarly finished items to preclude nonuniform oxidation and discoloration.
- G. Field Welding: Comply with applicable AWS specification for procedures of manual shielded metal arc welding and requirements for welding and for finishing welded connections in "Fabrication, General" Article. Weld connections that are not to be left as exposed joints but cannot be shop welded because of shipping size limitations.

- H. Field Brazing: Comply with requirements for brazing and for finishing brazed connections in "Fabrication, General" Article. Braze connections that are not to be left as exposed joints but cannot be shop brazed because of shipping size limitations.
- I. Control of Corrosion: Prevent galvanic action and other forms of corrosion by insulating metals and other materials from direct contact with incompatible materials.
 - 1. Coat concealed surfaces of aluminum that will be in contact with grout, concrete, masonry, or dissimilar metals, with a heavy coat of bituminous paint.

3.03 INSTALLING COLOR STAINLESS STEEL CLADDING ON RETAINING ALL

- A. Fasten zee-clip frames to concrete and masonry walls with cast-in-place or post-installed anchors. Mount framed cladding at height and in positions indicated on Contract Drawings.

3.04 INSTALLING STAINLESS STEEL DOOR AND BI-FOLDING DOORS

- A. Install single and bi-folding doors as shown in drawing.
- B. Align joints between doors with adjacent panels per approved shop drawing.

3.05 CLEANING AND PROTECTION

- A. Remove strippable film. Clean exposed surfaces in accordance with manufacturer's instructions. Protect exposed surfaces from damage by subsequent construction.
- B. Protect finishes of decorative metal from damage during construction period with temporary protective coverings approved by decorative metal fabricator. Remove protective covering at time of Substantial Completion.
- C. Restore finishes damaged during installation and construction period so no evidence remains of correction work. Return items that cannot be refinished in the field to the shop; make required alterations and refinish entire unit or provide new units.

3.06 PROTECTION

- A. Protect finishes of decorative metal items from damage during construction period. Remove temporary protective coverings at time of Substantial Completion.

3.07 CONTRACT CLOSEOUT

- A. Provide in accordance with Section 017700.

END OF SECTION 057010

NO TEXT ON THIS PAGE

SECTION 057020 - DECORATIVE METAL - TRELLIS CANOPY

PART 1 - GENERAL

1.01 SUMMARY

A. Section Includes:

1. Non-Directional #4 Finish Stainless Steel Trellis Shade Canopy Cladding and Structural Tubes.

1.02 PAYMENT

- A. No separate payment shall be made for performing any Work required under this Section. All costs for Work required by this Section shall be included in the applicable Cove Park lump sum(s) as set forth in Section 012901.

1.03 RELATED SECTIONS

- A. General Conditions Article 4.7 – Shop Drawings and Other Submittals.
- B. Section 012901 – Measurement and Payment
- C. Section 014300 - Quality Requirements.
- D. Section 016100 - Control of Materials.
- E. Section 017423 – Cleaning Up
- F. Section 017700 - Contract Closeout.

1.04 COORDINATION

- A. Coordinate installation of anchorages for decorative metal items. Furnish setting drawings, templates, and directions for installing anchorages, including sleeves, concrete inserts, anchor bolts, and items with integral anchors, that are to be embedded in concrete or masonry. Deliver such items to Project site in time for installation.

1.05 PREINSTALLATION MEETINGS

- A. Preinstallation Conference: Conduct conference at Project site.

1.06 SUBMITTALS

- A. Submit the following items in accordance with General Conditions Article 4.7

- B. Product Data: For each type of product, including finishing materials.
 - C. Shop Drawings: Show fabrication and installation details for decorative metal.
 - 1. Include plans, elevations, sections, jointing, component details, and attachment details.
 - 2. Indicate materials and profiles of each decorative metal member, fittings, joinery, finishes, fasteners, anchorages, and accessory items.
 - D. Samples for Initial Selection: For products involving selection of color, texture finish, or design.
 - E. Samples for Verification: For each type of exposed finish.
 - 1. Sections of linear shapes.
 - 2. Full-size Samples of castings and forgings.
 - a. For custom castings, submit finished Samples showing ability to reproduce detail, and quality of finish.
 - 3. Samples of welded and brazed joints showing quality of workmanship and color matching of materials.
 - F. Qualification Data: For installer, fabricator, colored and textured stainless steel finisher.
 - G. Mill Certificates: Signed by manufacturers of stainless-steel certifying that products furnished comply with requirements.
 - H. Welding certificates.
- 1.07 QUALITY ASSURANCE
- A. Comply with the requirements under Section 014300.
 - B. Fabricator Qualifications: A firm experienced in producing decorative metal similar to that indicated for this Project and with a record of successful in-service performance, as well as sufficient production capacity to produce required units.
 - C. Installer Qualifications: Fabricator of products.
 - D. Organic-Coating Applicator Qualifications: A firm experienced in successfully applying organic coatings, of type indicated, to aluminum extrusions and employing competent control personnel to conduct continuing, effective quality-control program to ensure compliance with requirements.

- E. Anodic Finisher Qualifications: A firm experienced in successfully applying anodic finishes of type indicated and employing competent control personnel to conduct continuing, effective quality-control program to ensure compliance with requirements.
 - F. Powder-Coating Applicator Qualifications: A firm experienced in successfully applying powder coatings of type indicated and employing competent control personnel to conduct continuing, effective quality-control program to ensure compliance with requirements.
 - G. Welding Qualifications: Qualify procedures and personnel according to the following:
 - 1. AWS D1.1/D1.1M, "Structural Welding Code - Steel."
 - 2. AWS D1.3/D1.3M, "Structural Welding Code - Sheet Steel."
 - 3. AWS D1.6/D1.6M, "Structural Welding Code - Stainless Steel."
 - H. Mockups: Build mockups to verify selections made under Sample submittals, to demonstrate aesthetic effects, and to set quality standards for fabrication and installation.
 - 1. Build mockups as shown in Drawings and constructed per approved Shop Drawings for the following types of decorative metal with full size components and panel including supports, bracing, attachments, stiffeners, assembly, suspension system and accessories:
 - a. Trellis Shade Canopy.
 - 2. Approval of mockups does not constitute approval of deviations from the Contract Documents contained in mockups unless Architect specifically approves such deviations in writing.
 - 3. Subject to compliance with requirements, approved mockups may become part of the completed Work if undisturbed at time of Substantial Completion.
- 1.08 DELIVERY, STORAGE, AND HANDLING
- A. Comply with the requirements under Section 016100.
 - B. Store decorative metal in a well-ventilated area, away from uncured concrete and masonry, and protected from weather, moisture, soiling, abrasion, extreme temperatures, and humidity.
 - C. Deliver and store cast-metal products in wooden crates surrounded by enough packing material to ensure that products are not cracked or otherwise damaged.

1.09 FIELD CONDITIONS

- A. Field Measurements: Verify actual locations of walls and other construction contiguous with decorative metal by field measurements before fabrication and indicate measurements on Shop Drawings.

PART 2 - PRODUCTS

2.01 DECORATIVE METAL TRELLIS CANOPY FABRICATORS AND INSTALLERS

- A. Fabricator and Installer: Subject to compliance with requirements, provide decorative stainless steel metal work by one of the following:
 1. Bamco Inc., 30 Baekeland Avenue, Middlesex, NJ 08846.
 2. Hi Tech Metals, 59-20 56th Avenue, Maspeth, NY 11378.
 3. Altona Custom Metal, 23 N Washington Ave., Little Ferry, NJ 07643.
 4. Or approved equal.

2.02 METALS, GENERAL

- A. Metal Surfaces, General: Use materials with smooth, flat surfaces unless otherwise indicated. Use materials without seam marks, roller marks, rolled trade names, stains, discolorations, or blemishes.

2.03 STAINLESS STEEL

- A. Tubing: ASTM A 554, Grade MT 316L.
- B. Pipe: ASTM A 312/A 312M, Grade TP 316L.
- C. Sheet, Strip, Plate, and Flat Bar: ASTM A 666, Type 316L.
- D. Bars and Shapes: ASTM A 276, Type 316L.
- E. Wire Rope and Fittings:
 1. Wire Rope: 7-by-19 wire rope made from wire complying with ASTM A 492, Type 316L.
 2. Wire-Rope Fittings: Connectors of types indicated, fabricated from stainless steel, and with capability to sustain without failure a load equal to minimum breaking strength of wire rope with which they are used.

2.04 FASTENERS

- A. Fastener Materials: Unless otherwise indicated, provide the following:
 - 1. Stainless-Steel Items: Type 316L stainless-steel fasteners.
 - 2. Titanium Items: Type 316L stainless-steel fasteners.
 - 3. Uncoated-Steel Items: Plated steel fasteners complying with ASTM B 633, Class Fe/Zn 25 for electrodeposited zinc coating where concealed, Type 316L stainless-steel fasteners where exposed.
 - 4. Galvanized-Steel Items: Plated steel fasteners complying with ASTM B 633, Class Fe/Zn 25 for electrodeposited zinc coating.
 - 5. Dissimilar Metals: Type 316L stainless-steel fasteners.
- B. Fasteners for Anchoring to Other Construction: Unless otherwise indicated, select fasteners of type, grade, and class required to produce connections suitable for anchoring indicated items to other types of construction indicated.
- C. Provide concealed fasteners for interconnecting components and for attaching decorative metal items to other work unless exposed fasteners are unavoidable.
 - 1. Provide tamper-resistant recessed machine screws for exposed fasteners unless otherwise indicated.
- D. Post-Installed Anchors: Fastener systems with an evaluation report acceptable to authorities having jurisdiction, based on ICC-ES AC193.
 - 1. Material for Interior Locations: Carbon-steel components zinc plated to comply with ASTM B 633 or ASTM F 1941, Class Fe/Zn 5 unless otherwise indicated.
 - 2. Material for Exterior Locations and Where Stainless Steel Is Indicated: Alloy Group 2 (A4) stainless-steel bolts, ASTM F 593 (ASTM F 738M), and nuts, ASTM F 594 (ASTM F 836M).

2.05 MISCELLANEOUS MATERIALS

- A. Welding Rods and Bare Electrodes: Select according to AWS specifications for metal alloy welded.
 - 1. For aluminum, provide type and alloy as recommended by producer of metal to be welded and as required for color match, strength, and compatibility in fabricated items.

- B. Brazing Rods: For copper alloys, provide type and alloy as recommended by producer of metal to be brazed and as required for color match, strength, and compatibility in fabricated items.
- C. Etching Cleaner for Galvanized Metal: Complying with MPI#25.
- D. Low-Emitting Paints and Coatings: Paints and coatings applied to interior decorative metal items shall comply with the testing and product requirements of the New Jersey Department of Environmental Protection Division of Air Quality, Regulatory Development, New Jersey Administrative Code Title 7, Chapter 27, 27A and 27B; and California Department of Public Health's (formerly, the California Department of Health Services') "Standard Method for the Testing and Evaluation of Volatile Organic Chemical Emissions from Indoor Sources Using Environmental Chambers."
- E. Galvanizing Repair Paint: High-zinc-dust-content paint complying with SSPC-Paint 20 and compatible with paints specified to be used over it.
- F. Lacquer for Copper Alloys: Clear, acrylic lacquer specially developed for coating copper-alloy products.
- G. Shop Primers: Provide primers that comply with "High-Performance Coatings."
- H. Universal Shop Primer for Ferrous Metal: Fast-curing, lead- and chromate-free, universal modified-alkyd primer complying with MPI#79 and compatible with topcoat.
 - 1. Use primer containing pigments that make it easily distinguishable from zinc-rich primer.
- I. Epoxy Zinc-Rich Primer: Complying with MPI#20 and compatible with topcoat.
- J. Shop Primer for Galvanized Steel: Comply with High-Performance Coatings.
- K. Intermediate Coats and Topcoats for Steel: Provide products that comply with High-Performance Coatings.
- L. Epoxy Intermediate Coat for Steel: Complying with MPI#77 and compatible with primer and topcoat.
- M. Polyurethane Topcoat for Steel: Complying with MPI#72 and compatible with undercoat.
- N. Bituminous Paint Isolation Coating: Cold-applied asphalt emulsion complying with ASTM D 1187/D 1187M.
- O. Silicone Joint Sealants: Single-Component, Non-sag, Neutral-Curing Silicon Joint Sealant complying with ASTM C920, Type S, Grade NS, Class 100/50, for Use NT is required to seal joints in decorative formed metal; and as recommended in writing by decorative formed metal manufacturer.

- P. Laminating Adhesive: Adhesive recommended by metal fabricator that will fully bond metal to metal, will prevent telegraphing and oil-canning, and is compatible with substrate and noncombustible after curing.

2.06 FABRICATION, GENERAL

- A. Assemble items in the shop to greatest extent possible to minimize field splicing and assembly. Disassemble units only as necessary for shipping and handling limitations. Clearly mark units for reassembly and coordinated installation. Use connections that maintain structural value of joined pieces.
- B. Make up wire-rope assemblies in the shop to field-measured dimensions with fittings machine swaged. Minimize amount of turnbuckle take-up used for dimensional adjustment so maximum amount is available for tensioning wire ropes. Tag wire-rope assemblies and fittings to identify installation locations and orientations for coordinated installation.
- C. Form decorative metal to required shapes and sizes, true to line and level with true curves and accurate angles and surfaces. Finish exposed surfaces to smooth, sharp, well-defined lines and arris.
- D. Form bent-metal corners to smallest radius possible without causing grain separation or otherwise impairing the Work.
- E. Form simple and compound curves in bars, pipe, tubing, and extruded shapes by bending members in jigs to produce uniform curvature for each configuration required; maintain cross section of member throughout entire bend without buckling, twisting, cracking, or otherwise deforming exposed surfaces.
- F. Cut, drill, and punch metals cleanly and accurately. Remove burrs and ease edges to a radius of approximately 1/32 inch (1 mm) unless otherwise indicated. Remove sharp or rough areas on exposed surfaces.
- G. Mill joints to a tight, hairline fit. Cope or miter corner joints. Fabricate connections that will be exposed to weather in a manner to exclude water.
- H. Provide weep holes where water may accumulate. Locate weep holes in inconspicuous locations.
- I. Provide necessary rebates, lugs, and brackets to assemble units and to attach to other work. Cut, reinforce, drill, and tap as needed to receive finish hardware, screws, and similar items unless otherwise indicated.
- J. Comply with AWS for recommended practices in shop welding and brazing. Weld and braze behind finished surfaces without distorting or discoloring exposed side. Clean exposed welded and braze] joints of flux, and dress exposed and contact surfaces.

1. Where welding and brazing cannot be concealed behind finished surfaces, finish joints to comply with NOMMA's "Voluntary Joint Finish Standards" for Type 1 Welds: no evidence of a welded joint.
 - K. Provide castings that are sound and free of warp, cracks, blowholes, or other defects that impair strength or appearance. Grind, wire brush, sandblast, and buff castings to remove seams, gate marks, casting flash, and other casting marks.
- 2.07 NONDIRECTIONAL #4 SATIN FINISH STAINLESS STEEL TRELLIS SHADE CANOPY
- A. General: Fabricate nondirectional #4 finish stainless steel Trellis Shade Canopy to designs as shown in drawing from stainless steel plates of 1/4" thickness minimum, 3.5" outside diameter stainless steel tubes and shapes of sizes and profiles indicated. Form stainless steel pipes by bending, forging, coping, mitering, and welding.
 - B. Stud-Welding: Interconnect trellis plates, structural pipe members with stud-welds and bolt to stainless steel U-shape connector plates unless otherwise indicated or approved in Shop Drawing. Use welding method that is appropriate for stainless steel and finish indicated and that develops full strength of members joined. Finish exposed welds and surfaces smooth, flush, and blended to match adjoining surfaces.
 - C. U-Shape Brackets, Fittings, and Anchors: Provide stainless steel u-shape brackets, fittings, and anchors to connect trellis plates to pipe structure unless otherwise indicated.
 1. Furnish inserts and other anchorage devices to connect trellis plates to shaped structure pipe work. Coordinate anchorage devices with supporting structure.
 2. Fabricate anchorage devices that are capable of withstanding loads indicated.
- 2.08 FINISHES, GENERAL
- A. Comply with NAAMM's "Metal Finishes Manual for Architectural and Metal Products" for recommendations for applying and designating finishes.
 - B. Protect mechanical finishes on exposed surfaces from damage by applying a strippable, temporary protective covering before shipping.
- 2.09 STAINLESS-STEEL FINISHES
- A. Surface Preparation: Remove tool and die marks and stretch lines, or blend into finish.
 - B. Polished Finishes: Grind and polish surfaces to produce uniform finish, free of cross scratches.
 1. Run grain of directional finishes with long dimension of each piece.

- C. Non-Directional Satin Finish: No. 4.
- D. When polishing is completed, passivate and rinse surfaces. Remove embedded foreign matter and leave surfaces chemically clean.
- E. Sputter-Coated Finish: Titanium nitride coating deposited by magnetic sputter-coating process over indicated mechanical finish.
- F. Colored, Oxide-Film Finish: Clear, oxide interference film produced by degreasing and then immersing in a mixture of chromic and sulfuric acids.
 - 1. Product: Subject to compliance with requirements, provide INCO colored stainless-steel finish.
 - 2. Color: Match Architect's color sample.

PART 3 - EXECUTION

3.01 EXAMINATION

- A. Examine substrates and conditions, with Installer present, for compliance with requirements for installation tolerances and other conditions affecting performance of decorative metal.
- B. Proceed with installation only after unsatisfactory conditions have been corrected.

3.02 INSTALLATION, GENERAL

- A. Provide anchorage devices and fasteners where needed to secure decorative metal to in-place construction.
- B. Perform cutting, drilling, and fitting required to install decorative metal. Set products accurately in location, alignment, and elevation, measured from established lines and levels. Provide temporary bracing or anchors in formwork for items to be built into concrete, masonry, or similar construction.
- C. Fit exposed connections accurately together to form tight, hairline joints or, where indicated, uniform reveals and spaces for sealants and joint fillers. Where cutting, welding, and grinding are required for proper shop fitting and jointing of decorative metal, restore finishes to eliminate evidence of such corrective work.
- D. Do not cut or abrade finishes that cannot be completely restored in the field. Return items with such finishes to the shop for required alterations, followed by complete refinishing, or provide new units as required.
- E. Install concealed gaskets, joint fillers, insulation, and flashings as work progresses.

- F. Restore protective coverings that have been damaged during shipment or installation. Remove protective coverings only when there is no possibility of damage from other work yet to be performed at same location.
 - 1. Retain protective coverings intact; remove coverings simultaneously from similarly finished items to preclude nonuniform oxidation and discoloration.
- G. Field Welding: Comply with applicable AWS specification for procedures of manual shielded metal arc welding and requirements for welding and for finishing welded connections in "Fabrication, General" Article. Weld connections that are not to be left as exposed joints but cannot be shop welded because of shipping size limitations.
- H. Field Brazing: Comply with requirements for brazing and for finishing brazed connections in "Fabrication, General" Article. Braze connections that are not to be left as exposed joints but cannot be shop brazed because of shipping size limitations.
- I. Control of Corrosion: Prevent galvanic action and other forms of corrosion by insulating metals and other materials from direct contact with incompatible materials.
 - 1. Coat concealed surfaces of aluminum that will be in contact with grout, concrete, masonry, or dissimilar metals, with a heavy coat of bituminous paint.

3.03 CLEANING AND PROTECTION

- A. Comply with the requirements of Section 017423
- B. Unless otherwise indicated, clean metals by washing thoroughly with clean water and soap, rinsing with clean water, and drying with soft cloths.
- C. Protect finishes of decorative metal from damage during construction period with temporary protective coverings approved by decorative metal fabricator. Remove protective covering at time of Substantial Completion.
- D. Restore finishes damaged during installation and construction period so no evidence remains of correction work. Return items that cannot be refinished in the field to the shop; make required alterations and refinish entire unit or provide new units.

3.04 PROTECTION

- A. Protect finishes of decorative metal items from damage during construction period. Remove temporary protective coverings at time of Substantial Completion.

3.05 CONTRACT CLOSEOUT

- A. Provide in accordance with Section 017700.

END OF SECTION 057020

NO TEXT ON THIS PAGE

SECTION 057300 - DECORATIVE METAL RAILINGS AND FENCES

PART 1 - GENERAL

1.01 DESCRIPTION

- A. Provide stainless-steel guardrails, handrails, fences and gates as indicated and in compliance with Contract Documents. Guardrails, handrails, fences and gates are a delegated design item as per 1.05 A herein.
 - 1. Stainless-steel guardrails and handrails complete with all accessories, stainless steel flexible mesh guardrail infill, brackets attachment and lighting devices as described in this Section.
 - 2. Stainless-steel decorative illumined railing system with posts designed to mount with anchors for floor/slab anchors or inserts.
 - 3. Decorative stainless-steel fences.
 - 4. Decorative stainless-steel swing gates.
 - 5. Mounting attachments to be supplied, engineered and approved by manufacturer.
 - 6. Field measuring for sleeves, inserts, and bracket locations, and slope, rise and run, and lengths.

1.02 PAYMENT

- A. No separate payment shall be made for performing any Work required under this Section. All costs for Work required by this Section shall be included in the applicable Cove Park lump sum(s), as set forth in Section 012901.

1.03 REFERENCES

- A. American National Standards Institute (ANSI)
 - 1. ANSI A58.1 Minimum Design Loads in Buildings and Other Structures.
 - 2. ICC/ANSI A117.1 Accessible and Usable Buildings and Facilities.
- B. American Society for Testing and Materials (ASTM)
 - 1. A 176 Specification for Stainless and Heat Resisting Chromium-Nickel Steel Plate, Sheet, and Strip.

2. A 269 Specification for Seamless and Welded Austenitic Stainless Steel Tubing for General Service.
 3. A 312 Specification for Seamless and Welded Austenitic Stainless Steel Pipe.
 4. E 84 Test Method for Surface Burning Characteristics of Building Materials.
 5. E 894 Standard Test Methods for Anchorage of Permanent Metal Railing Systems and Rails for Buildings.
 6. E 935 Standard Test Methods for Performance of Permanent Metal Railing Systems and Rails for Buildings.
 7. E 985 Specification for Permanent Metal Railing Systems and Rails for Buildings.
- C. Americans With Disabilities Act Accessibility Guidelines (ADAAG)
- D. International Code Council (ICC)
1. International Building Code (IBC)
 2. International Residential Code (IRC)
- E. National Fire Protection Association (NFPA)
1. National Electrical Code (NEC)
- F. Underwriters Lapidaries (UL)
1. Underwriters Laboratories, Inc. (U.L.)

1.04 RELATED SECTIONS

- A. General Conditions Article 4.7 – Shop Drawings and Other Submittals
- B. Section 012901 – Measurement and Payment
- C. Section 016100 – Control of Materials
- D. Section 017423 – Cleaning Up
- E. Section 017700 – Contract Closeout
- F. Section 033000 - Cast-in-Place Concrete.
- G. Section 034500 – Site Precast Architectural Concrete
- H. Section 061533 - Decking.

- I. Section 265619 - LED Lighting.
- J. Section 323300 - Site Furnishings.

1.05 REQUIREMENTS

- A. Contractor Design: All work associated with precast elements is to be performed as a delegated design and build. Contractor is to provide final design, engineering, fabrication.
 - 1. General: Design and engineering of guardrail, handrail and fence elements to be developed in accordance with building codes for structural loads and capacities.
 - 2. Contractor to provide all calculations and analysis, including but not limited to:
 - a. Base plates and bolt sizes.
 - b. Post design.
 - c. Infil panel wire mesh.
 - d. Top rail design.
 - e. Gates and Hinges.
 - 3. Contractor is to coordinate work of others associated to features railings and fences are attached to including but not limited to:
 - a. Precast architectural concrete stairs.
 - b. Retaining walls.
 - c. Cast in place concrete pathways.
 - d. Pedestrian bridge.
 - e. Resist Structure.
 - 4. Delegated Design: Engage a qualified professional engineer licensed in the State of New Jersey to design railings, including attachment to pathways, walls and other site features.
 - 5. Structural Performance: Railings, including attachment to site features, shall withstand the effects of gravity loads and the following loads and stresses within limits and under conditions indicated:
 - a. Handrails and Top Rails of Guards:
 - 1) Uniform load of 50 lbf/ft applied in any direction.

- 2) Concentrated load of 200 lbf applied in any direction.
 - 3) Uniform and concentrated loads need not be assumed to act concurrently.
 - b. Infill of Guards:
 - 1) Concentrated load of 50 lbf applied horizontally on an area of 1 sq ft.
 - 2) Infill load and other loads need not be assumed to act concurrently.
 - c. In addition to the above, follow all local Municipal and State building code requirements for rail structural performance, whichever is greater. Contractor to confirm structural performance of railings meets all code requirements.
6. Thermal Movements: Allow for thermal movements from ambient and surface temperature changes acting on exterior railings by preventing buckling, opening of joints, overstressing of components, failure of connections, and other detrimental effects.
- B. Furnish all transportation, labor, materials and equipment to perform the following: Furnish and install stainless-steel guardrails, handrails, fences, gates and accessories necessary to complete the work.
- C. Preconstruction Testing: Engage a qualified testing agency to perform preconstruction testing on laboratory mockups. Payment for these services will be made by Contractor. Retesting of products that fail to meet specified requirements shall be done at Contractor's expense.
1. Build laboratory mockups at testing agency facility; use personnel, materials, and methods of construction that will be used at Project site.
 2. Test railings in accordance with ASTM E 894 and ASTM # 935.
 3. Notify Construction Manager and Architect/Engineer seven (7) days in advance of the dates and times when laboratory mockups will be tested.

1.06 SUBMITTALS

- A. Submit shop drawings and product data under provisions of General Conditions Article 4.7.
- B. Submit engineered and stamped shop drawings for all delegated design for review and approval for design intent prior to mock up and/or fabrication.
- C. Shop drawings: Prepare project specific information, drawn accurately to scale. Submit large scale dimensioned drawings, showing detail fabrication and installation of each element indicated in the drawings. Indicate locations, plans, elevations, dimensions, shapes, and cross sections. Do not base Shop Drawings on reproductions of the Contract

Documents or standard printed data. Shop Drawings are to be coordinated, showing the full fabrication of railing system including lighting, mesh metalwork, bar table top, leaning signage, leaning wood, attachment, and with all relevant, related and adjacent components.

1. Preparation: Fully illustrate requirements in the Contract Documents. Include the following information, as applicable:
 - a. Identification of all products used in fabrication(s).
 - b. Indicate jointing, reveals, patterns, and extent and location of each surface finishes.
 - c. Schedules of parts, fabrication pieces, hardware, anchors, fasteners and finishes.
 - d. Indicate welded connections by AWS standard symbols. Indicate net weld lengths. Include details of welding materials, equipment, sequence and technique to be used.
 - e. Indicate locations, tolerances, and details of anchorage devices to be embedded in or attached to structure or other construction.
 - f. Compliance with specified standards and codes.
 - g. Notations of coordination requirements and sequencing of work.
 - h. Field verification and notation of dimensions based established upon actual field conditions and adjacent structures. Where items must fit and coordinate with finished surfaces and/or constructed spaces, take measurements at the site and not from drawings.
 - i. Relationship and attachment to adjoining construction clearly indicated.
 - j. Fully fabricated unit(s). Drawings to show work by multiple trades in a single drawing set to assure coordination of work.
 - k. Seal and signature of a professional engineer if specified. Structural drawings and calculations prepared and signed by a licensed engineer registered in the State of New Jersey.
 - l. Design Modifications: If design modifications are proposed by Contractor to meet performance requirements and field conditions, Contractor to submit design calculations with Shop Drawings to be reviewed by structural engineer of record for the project. Do not adversely affect the appearance, durability, or strength of units when modifying details or materials and maintain the general design concept.

- D. Submit manufacturer’s installation instructions
 - 1. X-TEND® Stainless Steel Flexible Mesh Guardrail Infill
 - 2. Jakob Rope Systems Webnet Stainless Steel Net
 - 3. Or approved equal.
- E. Samples for Verification: For each type of exposed finish required. The following samples shall be submitted for approval prior to fabrication. Accepted samples become the standard for acceptance for the work.
 - 1. Sections of each distinctly different linear railing and fence member, at least 12-inch in length including finish, including the following:
 - a. Handrails.
 - b. Guardrail top rails of each type identified in the Contract Documents:
 - 1) Typical guardrail rail top.
 - 2) Leaning guardrail rail top with laser cut lettering.
 - 3) Leaning guardrail rail top with wood top.
 - 4) Bar Table guardrail top with wood top.
 - c. Posts.
 - 2. Railing fittings and brackets.
 - 3. Infil materials for guardrails. Provide three (3) 12-inch by 12-inch square sections of flexible stainless steel mesh.
- F. Any Substitutions or changes in specified material must meet requirements of General Conditions Article 4.7.

1.07 QUALITY ASSURANCE

- A. Fabricator and Installer Qualifications: Firm experienced in successfully producing metal fabrications, railings, fences, and gates similar to that indicated for this Project, with sufficient production capacity to produce required units without causing delay in the work.
- B. Welding Qualifications: Qualify welding processes and welding operators in accordance with the following:
 - 1. AWS D1.1/D1.1M, “Structural Welding Code-Steel”.

2. AWS D1.6/D1.6M, "Structural Welding Code-Stainless Steel".
 3. Certify that each welder has satisfactorily passed AWS qualification test for welding processes involved.
- C. Fabrication quality shall be minimum NAAMM Class 1 finish.
- D. All stainless steel materials are to be pickled and passivated.
- E. All metal finishes shall be in accordance with NAAMM/NOMMA Metal Finishes Manual.
- F. Regulatory Requirements
1. Components and installation are to be in accordance with all local, state and federal codes and jurisdictions having authority.
 2. Components and installation are to follow current ADA Section 36, ICC/ANSI A117.1, International Building Code guidelines or any local or state codes or amendments, whichever is most restrictive.
- G. Furnish documentation that all components and fittings are furnished by the same manufacturer or approved by the primary component manufacturer.
1. Furnish documentation that components were installed in accordance to the manufacturer's installation requirements and engineering data to meet the specified design loads.
- H. Arrange a pre-installation meeting based on the following requirements:
1. Prior to the beginning of design development and shop drawing preparation, conduct a pre-job conference at the job site with seven calendar days advance written notice ensuring the attendance by competent authorized representatives of the fabricator, building owner's representative, landscape architect, architect and all subcontractors whose work interfaces with the work of this section.
 2. Review the specifications to determine any potential coordination issues, changes in scope and/or design, installation scheduling and requirements, job site conditions and procedures and/or any other information pertinent to the installation.
 3. Construction manager shall record the results of the conference and furnish copies to all participants within one week.
- I. Mockups: Provide mock-up of each type of installation using approved materials and specified methods of installation. Mockups are constructed to verify selections made under sample submittals; to demonstrate aesthetic effects and, where indicated, qualities of materials and execution; to review coordination, testing, or operation; to show the interface between materials, and to demonstrate compliance with specified installation

tolerances. Mock-ups are for evaluation of application workmanship and determine the standard for all work under the scope of work will be judged. Obtain Construction Manager, Architect, and Landscape Architect acceptance of mockup prior to start of installation of future work.

1. Mockups are not samples and are to be fully complete showing all aspects of work as required for review.
2. Mockup Plan: Prior to construction of mockup contractor to provide dimensional drawings detailing mockup size, and items and materials that will be included in the proposed mockup. Submit drawings for review and approval before constructing mockup.
3. Mockup Types: Types of Mockups are to be reviewed and approved by Construction Manager, Architect, and Landscape Architect.
 - a. Preliminary Mockup for Color, Finish, and Design Intent: Mockups of a segment of a part of the final fabricated element. This includes but is not limited to brackets, connections, partial panels. Construct a mockup for confirming design intent of each guardrail and handrail condition as submitted within 1.06E.
 - 1) Mockups are to be labeled and dated.
 - 2) Retain approved preliminary mockup samples for comparison to final mockup.
 - b. Final Mockups: Construct mock ups of sufficient length to show at least two typical rail panel sizes for each rail type and for each transition between rail types as outline in this Section. Final Mockup to be approved by the Landscape Architect and Construction Manager.
 - a) Off-Site Mockups: An area that is constructed outside of the field of work and to be protected throughout the project. The mock-up to demonstrate the full interface of all rail types, rail terminations, and transitions between rail types. The mock-up to demonstrate the full interface of mounting conditions in each pavement, wall or curb condition and be representative of curved and straight plan geometry conditions as shown on the Contract Documents. This mockup once approved it shall be the standard from which the work will be judged: Review of Off-Site Mockups are to be located at the facility of production, or at a designated location on site that is not included as part of the area of work. The review can be done by visiting the site/facility, or at the discretion of Construction Manager and Landscape Architect, photo documentation may be allowed.

b) Mockups are to be labeled, dated and retained.

2) First in Place Mockups: These are locations in the site to verify that installation is in conformance to the approved Off-site mockup. Mock-up may be retained as a part of the finished work upon approval by Landscape Architect and the Construction Manager. If mock-up is not retained, remove and dispose of mock-up prior to the completion of the project.

2. All mock-ups are subject to approval by Landscape Architect and the Construction Manager.

1.08 DELIVERY, STORAGE, AND HANDLING

A. Comply with the requirements of Section 016100.

B. Deliver materials to the job site in good condition and properly protected against damage to finished surfaces.

C. Store material on site in a location and in a manner to avoid damage. Stacking shall be done in a way, which will prevent bending.

1. Store material in a clean, dry location away from uncured concrete and masonry. Cover with waterproof paper, tarpaulin, or polyethylene sheeting in a manner that will permit circulation of air inside the covering.

2. Keep handling on site to a minimum. Exercise particular care to avoid damage to finishes of material.

1.09 WARRANTY

A. General Description: In addition to manufacturer's guarantees or warranties, Work shall be warranted for one year from the date of Substantial Completion against defects in materials and workmanship.

B. Other Items Covered: Warranty shall cover repair of damage to any materials and workmanship resulting from defects in the materials and workmanship.

PART 2 - PRODUCTS

2.01 MATERIALS AND FINISHES

A. All metals used in the fabrications of landscape metal pieces shall be in conformance with following material types:

1. Stainless Steel Sheet, Strip, and Plate: ASTM A240/A240M or ASTM A666, Type 316

2. Plate and Sheet: ASTM A480, Stretcher level sheets.
 3. Bar Stock and Shapes: ASTM A276/A276M Type 316.
 4. Tubing: Stock and Shapes: ASTM A276/A276M Type 316.
 5. Pipe: ASTM A312/A312M, Grade TP 316
- B. All fasteners, hardware, and spacers associated with metalwork shall be 316 stainless steel.
- C. Finishes as per the Contract Drawings.
- D. All stainless steel materials are to be pickled and passivated.

2.02 HANDRAIL, GUARDRAIL, AND FENCING SYSTEMS

- A. Rails: Fabricate rails from stainless steel
1. Finish: No. 4 brushed finish.
- B. Fabricate posts from stainless steel tube.
1. Mounting: As indicated on Contract Drawings.
 2. Attach post to underside of railing by use of top post bracket.
 3. Finish: No. 4 brushed finish.
- C. LED Lighting Rail Fixture and Lamp
- D. Stainless Steel Flexible Mesh Guardrail Infill
1. Basis of Design: X-TEND® as manufactured and sold by: Carl Stahl DecorCable Innovations, Inc., 8080 South Madison Street, Burr Ridge, IL, (312) 474-1100, stainless steel flexible mesh manufactured by Jakob Rope System, or approved equal.
 - a. Material: Type 316 stainless steel 7x7 (or 7x19) wire rope joined with 316L316 stainless steel ferrules.
 - b. Cable Diameter x Mesh Aperture Dimensions
 - 1) 2.0mm x 50mm
 - c. Mesh Perimeter finishes:
 - 1) Closed loops with loose ferrules for “sewn-on” installation method.

- d. Ferrule Style:
 - 1) Seamless AISI 316L Stainless Steel Ferrule
- e. Support Frame Style: As shown on Contract Drawings.

2.03 FABRICATION

- A. General: Fabricate railings and guardrails in accordance with approved shop drawings and to comply with requirements indicated for design, dimensions, members sizes and spacing, details, finish, and anchorage, but not less than that required to support structural loads.
- B. Shop assemble railings to greatest extent possible to minimize field splicing and assembly. Disassemble units only as necessary for shipping and handling limitations.
 - 1. Clearly mark units for reassembly and coordinated installation.
 - 2. Use connections that maintain structural value of joined pieces.
- C. Cut, drill, and punch metals cleanly and accurately.
 - 1. Remove burrs and ease edges to a radius of approximately 1/32 inch unless otherwise indicated.
 - 2. Remove sharp or rough areas on exposed surfaces.
- D. Form work true to line and level with accurate angles and surfaces.
- E. Cut, reinforce, drill, and tap as indicated to receive finish hardware, screws, and similar items.
- F. Non-welded Connections: Connect members with concealed mechanical fasteners and fittings. Fabricate members and fittings to produce flush, smooth, rigid, hairline joints.
- G. Welded Connections: Use fully welded joints for permanently connecting railing and guardrail components. Grind welds smooth. Resulting weld after smoothing shall meet structural requirements shown on the approved shop drawings.
- H. Form changes in direction by radius bends of radius indicated in Contract Documents.
- I. Bend members in jigs to produce uniform curvature for each configuration required. Maintain cross section of member throughout entire bend without buckling, twisting, cracking, or otherwise deforming exposed surfaces of components.
- J. Close exposed ends of hollow railing members with prefabricated cap and end fittings of same metal and finish as railings.

PART 3 - EXECUTION

3.01 GENERAL INSTALLATION

- A. Install in accordance with shop drawings and manufacturer's instructions at locations indicated on the Contract Drawings.
- B. Erect work horizontal or parallel to rake of steps or ramp, rigid, and free from distortion or defects detrimental to appearance or performance.
- C. Use mechanical or adhesive joints per manufacturer's instructions for permanently connecting railing components at nonwelded connections. Seal all recessed holes of exposed locking screws using plastic cement filler colored to match finish of railings.
- D. Use fully welded joints for permanently connecting railing components at welded connections. Comply with requirements for welded connections.

3.02 FIXED EMBEDMENT/FREE STANDING POST

- A. For railing posts with fixed support posts cast into concrete slab embedment attachment, attach posts as indicated using fittings provided by manufacturer.
 - 1. Cast rectangular support post into concrete slab at 4 ft 0 inch on center and projecting 24" above slab surface unless otherwise noted in Contract Drawings. Slide guardrail post onto support post and secure with set screw.
 - 2. Position post with electrical driver over the electrical conduit stub-out. Plumb and level post as required with base level to surface.
 - 3. Install posts in concrete with cover anchorage joint with optional metal base.
 - 4. Install top rail and secure in place with factory fittings.
 - 5. Continue installing posts, tubes and cut as required to fit field conditions.
 - 6. Field connect electrical drivers per manufacturer's instructions.
 - 7. Leave anchorage joint exposed with 1/8-inch buildup, sloped away from post and provide small bead of clear epoxy sealant to accommodate cement material shrinkage.
- B. For railing posts with base mounted attachment, attach posts as indicated using fittings provided by manufacturer'.
 - 1. Drill holes for anchors (supplied by others) and install post (with anchors supplied by others) spaced horizontal distance between posts at 4 ft 0 inch on-center unless otherwise noted in Contract Drawings.

2. Position post with electrical driver over the electrical conduit stub-out. Plumb and level post as required with base level to surface.
3. Install top rail and secure in place with factory fittings.
4. Continue installing posts, tubes and cut as required to fit field conditions.
5. Field connect electrical drivers per manufacturer's instructions.

3.03 FLEXIBLE MESH GUARDRAIL INFILL

- A. Install mesh infill system in frame as indicated in accordance with manufacturer's instructions and the approved shop drawings.
- B. Provide anchorage devices and fittings to secure the in-place construction. Install mesh infill system plumb, level, square and taut.
- C. Use manufacturer's supplied mounting hardware.
- D. Terminate and tension mesh panels in accordance with manufacturer's instructions.
- E. Ensure mesh is clean, and without waves, kinks, or sags.

3.04 PROTECTION

- A. Protect railing system and finish from damage during construction.
- B. Provide wood blocks and padding to prevent damage to railing members and fittings during field installation.
- C. Provide temporary protective coverings approved by railing manufacturer. Remove protective coverings at the time of Substantial Completion.

3.05 FENCE INSTALLATION

- A. Install fences according to manufacturer's written instructions and to the lines and grades indicated.
- B. Clear the area on either side of the fence line to the extent indicated. Space line posts equidistant at intervals not exceeding 4 feet. Set terminal (corner and gate) posts whenever abrupt changes in vertical and horizontal alignment are encountered. Install fences by setting posts as indicated and fastening rails and infill panels to posts.
- C. Post Setting: Set posts in concrete curb at indicated spacing.
 1. Verify that posts are set plumb, aligned, and at correct height and spacing, and hold in position during setting with concrete or mechanical devices.

2. Cast rectangular support post into concrete slab at 4'0" on center and projecting 24" above slab surface unless otherwise noted in Contract Drawings. Slide fence post onto support post and secure with set screw. Posts Set in Concrete.
3. Space posts as indicated on the Contract Drawings.

3.06 GATE INSTALLATION

- A. Install gates according to manufacturer's written instructions, level, plumb, and secure for full opening without interference. Mount gates to swing as indicated. Attach hardware using tamper-resistant or concealed means. Install ground-set items in concrete for anchorage. Adjust hardware for smooth operation and lubricate where necessary.

3.07 ADJUSTING

- A. Gates: adjust gates to operate smoothly, easily, and quietly, free of binding, warp, excessive deflection, distortion, nonalignment, misplacement, disruption, or malfunction, throughout entire operational range. Confirm that latches and locks engage accurately and securely without forcing or binding.
- B. Lubricate hardware and other moving parts.

3.08 CLEANING

- A. Comply with the requirements of Section 017423.
- B. As installation is completed, wash thoroughly using clean water and soap or mild cleaners per manufacturer's recommendation; rinse with clean water.
- C. Do not use acid solution, steel wool or other harsh abrasives.
- D. If stain remains after washing, remove finish and restore in accordance with NAAMM/NOMMA Metal Finishes Manual.

3.09 SREPAIR OF DEFECTIVE WORK

- A. Remove stained or otherwise defective work and replace with material that meets Contract Document requirements.
- B. Repair damaged finish as directed by Construction Manager.
- C. Replace defective or damaged components as directed by Construction Manager.

3.10 COORDINATION WITH RELATED DISCIPLINES

- A. Contractor shall coordinate the locations of penetrations, reinforcement required for landscape metalwork scope items including, but not limited to, base plates, sleeves, anchors, fasteners, hardware, etc.; with the requirements of all related disciplines.

1. Review structural drawings which correspond to landscape drawings at each structural concrete penetration to determine reinforcing locations relative to landscape metalwork anchors, and coordinate those locations in the field to avoid conflicts.
- B. Contractor shall coordinate the work of their own sub-contractors with specialty and sole source contractors.

3.08 CONTRACT CLOSEOUT

- A. Provide in accordance with Section 017700.

END OF SECTION 057300

NO TEXT ON THIS PAGE

SECTION 057500 - DECORATIVE FORMED METAL

PART 1 - GENERAL

1.01 SUMMARY

A. Section Includes:

1. Decorative-metal-clad Shade Canopy with internal supporting structural framing.
2. Formed Flat Seam metal roof panels on Shade Canopy.

1.02 PAYMENT

- ##### A.
- No separate payment shall be made for performing any Work required under this Section. All costs for Work required by this Section shall be included in the applicable Cove Park lump sum, as set forth in Section 012901.

1.03 RELATED SECTIONS

- ##### A.
- General Conditions Article 4.7 – Shop Drawings and Other Submittals
- ##### B.
- Section 012901 – Measurement and Payment
- ##### C.
- Section 014300 - Quality Requirements
- ##### D.
- Section 016100 – Control of Materials
- ##### E.
- Section 017700 – Contract Closeout
- ##### A.
- Requirements from the following section also apply to this Section
1. Section 050513 - Shop Applied Coatings for Metal

1.04 COORDINATION

- ##### A.
- Coordinate installation of anchorages for decorative formed metal items and metal roof panels. Furnish setting drawings, templates, and directions for installing anchorages, including sleeves, concrete inserts, anchor bolts, and items with integral anchors, that are to be embedded in concrete or masonry. Deliver items to Project site in time for installation.
- ##### B.
- Coordinate installation of decorative formed metal with metal roof panels over internal supporting structural framing and adjacent construction to ensure that wall and roof

assemblies, flashings, trim, and joint sealants, are protected against damage from the effects of weather, age, corrosion, and other causes of deterioration.

1.05 PREINSTALLATION MEETINGS

- A. Preinstallation Conference: Conduct conference at Project site.

1.06 SUBMITTALS

- A. Submit the following shop drawings and product samples in accordance with General Conditions Article 4.7.
- B. Shop Drawings: Show fabrication and installation details for decorative formed metal, metal roof panels and the internal supporting structural framing.
 - 1. Include plans, elevations, component details, and attachment details.
 - 2. Indicate materials and profiles of each decorative formed metal member, fittings, joinery, finishes, fasteners, anchorages, and accessory items.
- C. Samples for Initial Selection: For products involving selection of color, texture, or design, including mechanical finishes.
- D. Samples for Verification: For each type of exposed finish required, prepared on 12-inch square Samples of metal of same thickness and material indicated for the Work.
- E. Delegated-Design Submittal: For installed products indicated to comply with performance requirements and design criteria, including analysis data signed and sealed by the qualified professional engineer licensed in New Jersey, responsible for their preparation.
- F. Coordination Drawings: For decorative formed metal elements and metal roof panels that house items specified in other Sections. Show dimensions of housed items, including locations of housing penetrations and attachments, and necessary clearances.
- G. Qualification Data: For Installer, fabricator, organic-coating applicator, anodic finisher, powder-coating applicator, and, professional engineer.
- H. Mill Certificates: Signed by stainless-steel manufacturers certifying that products furnished comply with requirements.
- I. Evaluation Reports: For post-installed anchors, from ICC-ES.
- J. Maintenance Data: For powder coating finish, mirrorlike stainless-steel finish, statuary conversion coating copper-alloy finish and patina–finish to include in maintenance manuals.

1.07 QUALITY ASSURANCE

- A. Comply with the requirements in Section 014300.
- B. Fabricator Qualifications: A firm experienced in producing decorative formed metal similar to that indicated for this Project and with a record of successful in-service performance as well as sufficient production capacity to produce required units.
- C. Organic-Coating Applicator Qualifications: A firm experienced in successfully applying organic coatings of type indicated to metals of types indicated and that employs competent control personnel to conduct continuing, effective quality-control program to ensure compliance with requirements.
- D. Anodic Finisher Qualifications: A firm experienced in successfully applying anodic finishes of type indicated and that employs competent control personnel to conduct continuing, effective quality-control program to ensure compliance with requirements.
- E. Powder-Coating Applicator Qualifications: A firm experienced in successfully applying powder coatings of type indicated to metals of types indicated and that employs competent control personnel to conduct continuing, effective quality-control program to ensure compliance with requirements.
- F. Patina Finisher Applicator Qualifications: A firm experienced in successfully applying patina finishes of type indicated and to metals of types indicated and that employs competent control personnel to conduct continuing, effective quality-control program to ensure compliance with requirements.
- G. Installer Qualifications: shall have five (5) years of relevant experience of installing similar systems.
- H. Mockups: Build mockups as shown in the drawing to verify selections made under Sample submittals, to demonstrate aesthetic effects, and to set quality standards for fabrication and installation.
 - 1. Build mockups of decorative formed metal and tie-in with metal roof panels.
 - 2. Subject to compliance with requirements, approved mockups may become part of the completed Work if undisturbed at time of Substantial Completion.

1.08 DELIVERY, STORAGE, AND HANDLING

- A. Comply with the requirements of Section 016100.
- B. Deliver decorative formed metal products and metal roof panels wrapped in protective coverings and strapped together in suitable packs or in heavy-duty cartons. Remove protective coverings before they stain or bond to finished surfaces.

- C. Store products on elevated platforms in a dry location.
- D. Retain strippable protective covering on decorative formed metal and metal roof panels during installation.

1.09 FIELD CONDITIONS

- A. Field Measurements: Verify actual locations of columns, beams, and other construction contiguous with decorative formed metal by field measurements before fabrication and indicate measurements on Shop Drawings.

PART 2 - PRODUCTS

2.01 PERFORMANCE REQUIREMENTS

- A. Delegated Design: Engage a qualified professional engineer, licensed to practice in New Jersey to design decorative formed metal, metal roof panels and internal supporting structural framing, including attachment to building construction.
- B. Structural Performance: Decorative formed metal items, metal roof panels and internal supporting structural framing, including anchors and connections, shall withstand the effects of gravity loads and the following loads and stresses without exceeding the allowable design working stress of materials involved and without exhibiting permanent deformation in any components:
 - 1. Wind Loads on Exterior Items: 30 lbf/sq. ft.
- C. Seismic Performance: Exterior decorative formed metal items metal roof panels and internal supporting structural framing, including anchors and connections, shall withstand the effects of earthquake motions determined according to ASCE/SEI 7.
 - 1. Component Importance Factor: 1.0.
- D. Wind-Uplift Resistance: Provide metal roof panel assemblies that comply with UL 580 for wind-uplift-resistance class indicated.
 - 1. Uplift Rating: UL90.
- E. Thermal Movements: Allow for thermal movements from ambient and surface temperature changes acting on exterior metal fabrications by preventing buckling, opening of joints, overstressing of components, failure of connections, and other detrimental effects.
 - 1. Temperature Change: 120 deg F, ambient; 180 deg F, material surfaces.

2.02 SHEET METAL

- A. General: Fabricate products from sheet metal without pitting, seam marks, roller marks, stains, discolorations, or other imperfections where exposed to view on finished units.
- B. Recycled Content of Steel Products: Postconsumer recycled content plus one-half of preconsumer recycled content not less than 25 percent.
- C. Aluminum Sheet: Flat sheet complying with ASTM B 209, alloy and temper recommended by aluminum producer and finisher for type of use and finish indicated, and with strength and durability properties of not less than Alloy 5005-H32.
- D. Galvanized-Steel Sheet: ASTM A 653/A 653M, G90 coating, either commercial steel or forming steel.
- E. Steel Sheet: Electrolytic zinc-coated, ASTM A 879/A 879M, with steel sheet substrate complying with ASTM A 1008/A 1008M, commercial steel, exposed.
- F. Stainless-Steel Sheet: ASTM A 240/A 240M or ASTM A 666, Type 316, stretcher-leveled standard of flatness.
- G. Bronze Sheet: ASTM B 36/B 36M, Alloy UNS C28000 (muntz metal, 60 percent copper) or Alloy UNS C23000 (red brass, 85 percent copper).
- H. Brass Sheet: ASTM B 36/B 36M, Alloy UNS C26000 (cartridge brass, 70 percent copper).
- I. Copper Sheet: ASTM B 370, cold-rolled copper sheet, H00 temper.
- J. Zinc Sheet: ASTM B-69-13 Type 1 and Type 2 for Architectural Rolled zinc.
- K. Titanium Sheet: ASTM B 265, Grade 1.

2.03 MISCELLANEOUS MATERIALS

- A. Gaskets: As required to seal joints in decorative formed metal and remain weathertight as recommended in writing by decorative formed metal manufacturer.
 - 1. ASTM D 1056, Type 1, Class A, grade as recommended by gasket manufacturer to obtain seal for application indicated.
 - 2. Closed-cell polyurethane foam, adhesive on two sides, release paper protected.
- B. Sealants, Exterior: ASTM C 920; nonstaining silicone sealant; of type, grade, class, and use classifications required to seal joints in decorative formed metal and remain weathertight; and as recommended in writing by decorative formed metal manufacturer.

Sealant color as selected by Architect/Engineer from manufacturer's product color chart.

- C. Sealants, Interior: Nonsag, paintable, nonstaining, latex sealant complying with ASTM C 834; of type and grade required to seal joints in decorative formed metal; and as recommended in writing by decorative formed metal manufacturer.
 - 1. Sealants shall have a VOC content of not more than 250 g/L when calculated according to 40 CFR 59, Subpart D (EPA Method 24).
 - 2. Sealants shall comply with the testing and product requirements of the California Department of Public Health's (formerly, the California Department of Health Services') "Standard Method for the Testing and Evaluation of Volatile Organic Chemical Emissions from Indoor Sources Using Environmental Chambers."
- D. Filler Metal and Electrodes: Provide type and alloy of filler metal and electrodes as recommended by producer of metal to be welded or brazed and as necessary for strength, corrosion resistance, and compatibility in fabricated items.
 - 1. Use filler metals that will match the color of metal being joined and will not cause discoloration.
- E. Fasteners: Fabricated from same basic metal and alloy as fastened metal unless otherwise indicated. Do not use metals that are incompatible with materials joined.
 - 1. Provide concealed fasteners for interconnecting decorative formed metal items and for attaching them to other work unless otherwise indicated.
 - 2. Provide tamper-resistant recessed flat-head machine screws for exposed fasteners unless otherwise indicated.
- F. Structural Anchors: For applications indicated to comply with certain design loads, provide fastener systems with working capacity greater than or equal to the design load, according to an evaluation report acceptable to authorities having jurisdiction, based on ICC-ES AC193 or ICC-ES AC308.
- G. Nonstructural Anchors: For applications not indicated to comply with design loads, provide fastener systems with an evaluation report acceptable to authorities having jurisdiction, based on ICC-ES AC193 or ICC-ES AC308.
- H. Anchor Materials:
 - 1. Material for Interior Locations: Carbon-steel components zinc plated to comply with ASTM B 633 or ASTM F 1941, Class Fe/Zn 5, unless otherwise indicated.

2. Material for Exterior Locations and Where Stainless Steel Is Indicated: Alloy Group 1 (A1) stainless-steel bolts, ASTM F 593, and nuts, ASTM F 594.
- I. Sound-Deadening Materials:
1. Insulation: Unfaced, mineral-fiber blanket insulation complying with ASTM C 665, Type I, and passing ASTM E 136 test.
 2. Mastic: Cold-applied asphalt emulsion complying with ASTM D 1187/D 1187M.
- J. Backing Materials: Provided or recommended by decorative formed metal manufacturer.
- K. Laminating Adhesive: Adhesive recommended by metal fabricator that will fully bond metal to metal, will prevent telegraphing and oil-canning, and is compatible with substrate and noncombustible after curing.
1. Contact Adhesive: VOC content of not more than 80 g/L when calculated according to 40 CFR 59, Subpart D (EPA Method 24).
 2. Metal-to-Metal Adhesive: VOC content of not more than 30 g/L when calculated according to 40 CFR 59, Subpart D (EPA Method 24).
 3. Multipurpose Construction Adhesive: VOC content of not more than 70 g/L when calculated according to 40 CFR 59, Subpart D (EPA Method 24).
 4. Special-Purpose Contact Adhesive: (Contact adhesive used to bond melamine-covered board, metal, unsupported vinyl, ultrahigh molecular weight polyethylene, and rubber or wood veneer, 1/16 inch thick or less, to any surface): 250 g/L.
 5. Adhesive shall comply with the testing and product requirements of the California Department of Public Health's (formerly, the California Department of Health Services') "Standard Method for the Testing and Evaluation of Volatile Organic Chemical Emissions from Indoor Sources Using Environmental Chambers."
- L. Isolation Coating: Manufacturer's standard bituminous paint.
1. Coating shall comply with the testing and product requirements of the New Jersey Department of Environmental Protection Division of Air Quality, Regulatory Development, New Jersey Administrative Code Title 7, Chapter 27, 27A and 27B; and California Department of Public Health's (formerly, the California Department of Health Services') "Standard Method for the Testing and Evaluation of Volatile Organic Chemical Emissions from Indoor Sources Using Environmental Chambers."

2.04 PAINTS AND COATINGS

- A. Low-Emitting Materials: Paints and coatings applied to interior/exterior decorative formed metal items shall comply with the testing and product requirements of the New Jersey Department of Environmental Protection Division of Air Quality, Regulatory Development, New Jersey Administrative Code Title 7, Chapter 27, 27A and 27B; and California Department of Public Health's (formerly, the California Department of Health Services') "Standard Method for the Testing and Evaluation of Volatile Organic Chemical Emissions from Indoor Sources Using Environmental Chambers."
- B. Etching Cleaner for Galvanized Metal: Complying with MPI#25.
- C. Galvanizing Repair Paint: High-zinc-dust-content paint complying with SSPC-Paint 20 and compatible with paints specified to be used over it.
- D. Lacquer for Copper Alloys: Clear, acrylic lacquer specially developed for coating copper-alloy products.
- E. Shop Primers: Comply with the Finished Paint manufacturer's recommendation and requirement.
- F. Universal Shop Primer for Ferrous Metal: Fast-curing, lead- and chromate-free, universal modified-alkyd primer complying with MPI#79 and compatible with topcoat.
 - 1. Use primer containing pigments that make it easily distinguishable from zinc-rich primer.
- G. Epoxy Zinc-Rich Primer: Complying with MPI#20 and compatible with topcoat.
- H. Shop Primer for Galvanized Steel: Water-based galvanized metal primer complying with MPI#134.
- I. Bituminous Paint: Cold-applied asphalt emulsion complying with ASTM D 1187/D 1187M.

2.05 FABRICATION, GENERAL

- A. Shop Assembly: Preassemble decorative formed metal items in shop to greatest extent possible to minimize field splicing and assembly. Disassemble units only as necessary for shipping and handling limitations. Clearly mark units for reassembly and coordinated installation.
- B. Coordinate dimensions and attachment methods of decorative formed metal items with those of adjoining construction to produce integrated assemblies with closely fitting joints and with edges and surfaces aligned unless otherwise indicated.

- C. Form metal to profiles indicated, in maximum lengths to minimize joints. Produce flat, flush surfaces without cracking or grain separation at bends. Fold back exposed edges of unsupported sheet metal to form a 1/2-inch wide hem on the concealed side, or ease edges to a radius of approximately 1/32 inch and support with concealed stiffeners.
- D. Increase metal thickness or reinforce with concealed stiffeners, backing materials, or both, as needed to provide surface flatness equivalent to stretcher-leveled standard of flatness and sufficient strength for indicated use.
 - 1. Support joints with concealed stiffeners as needed to hold exposed faces of adjoining sheets in flush alignment.
- E. Build in straps, plates, and brackets as needed to support and anchor fabricated items to adjoining construction. Reinforce decorative formed metal items as needed to attach and support other construction.
- F. Provide support framing, mounting and attachment clips, splice sleeves, fasteners, and accessories needed to install decorative formed metal items.
- G. Where welding or brazing is indicated, weld or braze joints and seams continuously. Grind, fill, and dress to produce smooth, flush, exposed surfaces in which joints are not visible after finishing is completed.
 - 1. Use welding and brazing procedures that will blend with and not cause discoloration of metal being joined.

2.06 SHADE CANOPY

- A. Fabricator and Installer:
 - 1. Bamco Inc., 30 Baekeland Avenue, Middlesex, NJ 08846.
 - 2. Hi Tech Metals, 59-20 56th Avenue, Maspeth, NY 11378.
 - 3. Pabco, 157 Gazza Blvd., Farmingdale, NY 11735.
 - 4. Or approved equal.
- B. Form Canopy Soffit and Column cladding from metal of type and thickness indicated below. Fabricate to fit tightly to adjoining construction.
 - 1. Aluminum Sheet: 18 gage (1.024 mm) or thickness required to comply with performance requirements.
 - a. Finish: High-performance organic coating to match Architect color sample.

2. Stainless-Steel Sheet: 20 gage (0.812 mm) or thickness required to comply with performance requirements.
 - a. Finish: Nondirectional #4 Satin Finish. Color to match Architect color sample.

- C. Fabricate with caulk stop angle to retain backer rod and sealant.
- D. Apply sound-deadening mastic to inside surface of column cladding.
- E. All folding edges and corner shall be back cut to produce sharp edge.

2.07 METAL ROOF PANELS

A. Fabricator and Installer:

1. Evolution System by Overly Manufacturing Company, Greensburg, PA 15601.
2. Flexloc by MBCI, Rome, NY 13440
3. Flat Lock Panels by Riverside Sheet Metal & Contracting Inc., Medford, MA 02155
4. Or approved equal

- B. Aluminum Sheets: 18 gauge or thickness required to comply with performance requirements
- C. Finish: High-performance organic coating to match Architect color sample.
- D. Provide and install Internal Drainage Channel and Compression Cover Plate.
- E. Fasteners: System fasteners shall be concealed and no less than a #12 stainless steel screw shall be used to anchor the internal drain channel; length and screw type as required for substrate construction.

2.08 GENERAL FINISH REQUIREMENTS

- A. Complete mechanical finishes of flat sheet metal surfaces before fabrication where possible. After fabrication, finish all joints, bends, abrasions, and other surface blemishes to match sheet finish.
- B. Protect mechanical finishes on exposed surfaces from damage by applying a strippable, temporary protective covering before shipping.
- C. Apply organic and anodic finishes to formed metal after fabrication unless otherwise indicated.

- D. Appearance of Finished Work: Variations in appearance of abutting or adjacent pieces are acceptable if they are within one-half of the range of approved Samples. Noticeable variations in the same piece are not acceptable. Variations in appearance of other components are acceptable if they are within the range of approved Samples and are assembled or installed to minimize contrast.

2.09 ALUMINUM FINISHES

- A. High-Performance Organic Finish: Four-coat fluoropolymer finish complying with AAMA 2605 and containing not less than 70 percent PVDF resin by weight in both color coat and clear topcoat. Prepare, pretreat, and apply coating to exposed metal surfaces to comply with coating and resin manufacturers' written instructions.
 - 1. Color and Gloss: To Match Architect's sample.

PART 3 - EXECUTION

3.01 EXAMINATION

- A. Examine substrates, areas, and conditions, with Installer present, for compliance with requirements for installation tolerances and other conditions affecting performance of decorative formed metal.
- B. Proceed with installation only after unsatisfactory conditions have been corrected.

3.02 INSTALLATION

- A. Locate and place decorative formed metal items level and plumb and in alignment with adjacent construction. Perform cutting, drilling, and fitting required to install decorative formed metal.
 - 1. Do not cut or abrade finishes that cannot be completely restored in the field. Return items with such finishes to the shop for required alterations, followed by complete refinishing, or provide new units as required.
- B. Use concealed anchorages where possible. Provide brass or lead washers fitted to screws where needed to protect metal surfaces and to make a weathertight connection.
- C. Form tight joints with exposed connections accurately fitted together. Provide reveals and openings for sealants and joint fillers as indicated.
- D. Install concealed gaskets, joint fillers, insulation, sealants, and flashings, as the Work progresses, to make exterior decorative formed metal items weatherproof.

- E. Install concealed gaskets, joint fillers, sealants, and insulation, as the Work progresses, to make interior decorative formed metal items soundproof or lightproof as applicable to type of fabrication indicated.
- F. Corrosion Protection: Apply bituminous paint or other permanent separation materials on concealed surfaces where metals would otherwise be in direct contact with substrate materials that are incompatible or could result in corrosion or deterioration of either material or finish.
- G. Field cutting aluminum panels by torch is not permitted.

3.03 ADJUSTING AND CLEANING

- A. Unless otherwise indicated, clean metals by washing thoroughly with water and soap, rinsing with clean water, and drying with soft cloths.
- B. Clean copper alloys according to metal finisher's written instructions in a manner that leaves an undamaged and uniform finish matching approved Sample.
- C. Touchup Painting: Immediately after erection, clean field welds, bolted connections, and abraded areas of shop paint and paint exposed areas with the same material as used for shop painting to comply with SSPC-PA 1 for touching up shop-painted surfaces.
 - 1. Apply by brush or spray to provide a minimum 2.0-mil dry film thickness.
- D. Touchup Painting: Cleaning and touchup painting of field welds, bolted connections, and abraded areas of shop paint are specified in Section 099110.
- E. Restore finishes damaged during installation and construction period so no evidence remains of correction work. Return items that cannot be refinished in the field to the shop; make required alterations and refinish entire unit or provide new units.

3.04 PROTECTION

- A. Protect finishes of decorative formed metal items from damage during construction period. Remove temporary protective coverings at time of Substantial Completion.

3.05 CONTRACT CLOSEOUT

- A. Provide in accordance with Section 017700.

END OF SECTION 057500

SECTION 058100 - PREFABRICATED EXPANSION JOINT ASSEMBLIES

PART 1 - GENERAL

1.01 SUMMARY

- A. This Section specifies requirements for exterior prefabricated expansion joint assemblies, stainless steel surface-mounted traffic plate, including seismic type, fire barriers and moisture barriers - for installation and connection between the Pedestrian Bridge and the Landscape walkway.

1.02 DESIGN AND PERFORMANCE REQUIREMENTS

- A. General: Expansion joint assemblies shall permit unrestrained movement of joint without disengagement of cover. Expansion joint assemblies shall also, where shown on the Contract Drawings and as required to suit project requirements, maintain fire-resistance ratings, maintain integrity of smoke barrier, prevent air infiltration, prevent moisture and water penetration, serve as finished architectural joint closures and remain in place upon exposure to seismic activity.
- B. Loading Characteristics: Joints shall withstand loading as established by product types shown, without damage or permanent deformation to the expansion joint assembly.
- C. Fire Performance Characteristics: Where indicated on the Contract Drawings, expansion joint assemblies shall incorporate fire barriers identical to those of assemblies whose fire resistance has been determined per ANSI/UL2079 or ASTM E1966, including hose stream test at full-rated period, by a nationally recognized testing and inspection organization.
 - 1. Fire Rating: Products shall be certified in writing to be capable of withstanding 150 degrees F (65 degrees C) for 3 hours while compressed down to the minimum of movement capability dimension of the basis of design product (-50% of nominal material size) without evidence of any bleeding of impregnation medium from the material.
- D. Accessibility Characteristics: As shown on the Contract Drawings along an accessible route, expansion joint assemblies shall comply with the Americans with Disability Act (ADA).

1.03 RELATED SECTIONS

- A. General Conditions Article 4.7 – Shop Drawings and Other Submittals
- B. Section 012901 – Measurement and Payment

C. Section 014300 – Quality Requirements

D. Section 017700 – Contract Closeout

1.04 PAYMENT

A. No separate payment shall be made for performing any Work required under this Section. All costs for Work required by this Section shall be included in the applicable Cove Park lump sum as set forth in Section 012901.

1.05 REFERENCES

A. American Architectural Manufacturers Association (AAMA)

1. 611 - Specification for Anodized Architectural Aluminum.
2. 2605 - Voluntary Specification, Performance Requirements and Test Procedures for Superior Performing Organic Coatings on Aluminum Extrusions and Panels.

B. American National Standards Institute (ANSI)/Underwriters Laboratories Inc. (UL)

1. 2079 - Tests for Fire Resistance of Building Joint Systems.

C. ASTM International (ASTM)

1. A36 - Specification for Carbon Structural Steel
2. A666 - Specification for Stainless and Heat-Resisting Chromium-Nickel Steel Plate, Sheet, and Strip.
3. B209 - Specification for Aluminum and Aluminum-Alloy Sheet and Plate.
4. B221 - Specification for Aluminum-Alloy Extruded Bars, Rods, Wire, Profiles, and Tubes.
5. D2000 - Standard Classification System for Rubber Products in Automotive Applications
6. E1399 - Test Method for Cyclic Movement and Measuring the Minimum and Maximum Joint Widths of Architectural Joint Systems.
7. E1966 - Test Method for Fire-Resistive Joint Systems

D. Society of Automotive Engineers (SAE)

E. Unified Numbering System for Metals and Alloys (UNS)

F. National Association of Architectural Metal Manufacturers (NAAMM)

1. Metal Finishes Manual for Architectural and Metal Products.

1.06 QUALITY ASSURANCE

- A. Comply with the requirements in Section 014300.
- B. Manufacturer Qualifications: Arrange for expansion joint assemblies specified in this Section to be furnished by a manufacturer with minimum five years experience in the fabrication of expansion joint assemblies involving quantities and complexities equal to or greater than those required by this Contract.
- C. Installer Qualifications: Arrange for expansion joint assemblies specified in this Section to be installed by an entity with minimum five years experience in the installation of assemblies involving quantities and complexities at least equal to those required by this Contract.
- D. Single Source Responsibility: Obtain expansion joint assemblies furnished and installed under this Section from a single manufacturer.

1.07 SUBMITTALS

- A. Submit the following items in accordance with General Conditions Article 4.7.
- B. Product Data: Manufacturer's product data, material and finish descriptions, installation instructions and general recommendations for each type of expansion joint assembly shown on the Contract Drawings.
- C. Shop Drawings: Show full extent of expansion joint assemblies; include large scale details of each type indicating profiles, splice joints between sections, joinery with other joint types including intersections, corner joints and tees, special end conditions, anchorages, fasteners, block-out locations and requirements, and relationship to adjoining Work and finishes.
 1. Include isometric drawings, as required to fully describe assemblies, depicting the continuity of their route and their intersections.
- D. Samples
 1. Preformed Seals: 6 inch long samples of each type of flexible seal material to be used in the Work. Include manufacturer's standard color charts showing full range of colors and textures available for each type of flexible seal material for selection by the Engineer.

2. For Verification: Full-size units 6 inches long of each type of joint system to be used in the Work, including all system components and showing finish, color, texture, patterns and full range of variations expected for these characteristics.

E. Certifications

1. All products must be certified by independent laboratory test report to be free in composition of any waxes or wax compounds using FTIR and DSC testing.
2. A FEA Report by a certified engineer must be submitted providing engineering information stating lateral and non-linear displacement and safety factors on key system components under conditions simulating a 4000 lb vehicle skidding across the joint system inducing an 800 lb tangential load. Product must demonstrate FEA Safety Factors: Traffic Plate - 5; Screws - 11; Spline Pins - 10; Center Spline - 7.
3. All products must be certified by independent laboratory test report to be tested to meet or exceed ASTM C1028 the standard method for determining Static Coefficient of Friction (SCOF).
4. All foam/spline/hangar-bar components shall be pre-assembled at the factory. No field assembly of component foam-to centering spline shall be allowed. No field assembly of metal-to-metal or plastic or rubber spline components shall be permitted.
5. Sealers, sealants, or saturates infused into the upper areas of the foam matrixes for the intended purpose of performing or contributing to performance as an elastomeric waterproofing layer in lieu of a silicone bellows layer shall NOT be permitted.
6. A silicone sealant band must be installed between the substrates and outer pre-cured silicone bellows throughout the length of the assembly as well as at the interface of factory preassembled units.
7. Fire Performance: Where fire-rated expansion joint assemblies are shown, submit test data to indicate conformance with this Section.

F. Qualifications: Submit proof of manufacturer and installer experience qualifications.

1.08 COORDINATION

- A. Ensure that prefabricated expansion joint assemblies furnished and installed under this Section are compatible with expansion joint assemblies specified in other Sections.

1.09 DELIVERY, STORAGE, AND HANDLING

- A. Comply with the requirements in Section 016100.
- B. Handle expansion joint assemblies in manner to protect surfaces and to prevent distortion and other types of damage or deterioration during shipment, handling and storage. Store under cover and off ground and in accordance with manufacturer's installation instructions. Protect from weather and construction activities until installed and accepted.

1.10 WARRANTY

- A. Submit written warranty executed by the Contractor, installer and the manufacturer, agreeing to provide materials and labor to repair or replace expansion joint assemblies that fail in materials or workmanship within five years after date of issuance of the Certificate of Final Completion. This warranty shall not limit other rights the DEP may have under the Contract.

PART 2 - PRODUCTS

2.01 MANUFACTURERS

- A. Subject to compliance with the requirements of this Section, furnish and install products of one of the following, or approved equal:
 - 1. EMSEAL Joint System Ltd., Westborough, MA.
 - 2. Architectural Art Mfg., Inc., Wichita, KS
 - 3. Balco Inc., Wichita, KS
 - 4. Construction Specialties, Hughesville and Muncy, PA.
 - 5. MM Systems Corp., Pendergrass, GA
 - 6. Watson Bowman Acme Corp. (subsidiary of Degussa Corp.), Amherst, NY
 - 7. Or approved equal

2.02 MATERIALS

- A. Aluminum: ASTM B 221, alloy 6063-T5 for extrusions; ASTM B 209, alloy 6061-T6 for sheet and plate; mill finish, unless otherwise shown on the Contract Drawings.

1. Protect aluminum surfaces in contact with cementitious materials with zinc chromate primer or chromate conversion coating.
- B. Stainless Steel: ASTM A 666, Type 316 for plates, sheet, and strip; Beadblasted finish, unless otherwise shown on the Contract Drawings.
- C. Steel: ASTM A36, for plates, sheet, and strip, unless otherwise shown on the Contract Drawings.
- D. Elastomeric: Provide the manufacturer's standard, steel reinforced, premolded elastomeric anchor block material designed to capture extruded preformed seals and provide suitable anchoring flanges.
- E. Material shall be capable of movements of +50 percent, -50 percent (100 percent total) of nominal material size. Depth of seal as recommended by manufacturer.
- F. Sealant system shall be comprised of the following components:
 1. Cellular foam infused with a hydrophobic, modified-acrylic dispersion,
 2. Pre-coated with a watertight silicone outer coating,
 3. Heavy-duty extruded aluminum center spline,
 4. Interlocking spline connectors and heavy-duty cover plates,
 5. Field-applied epoxy adhesive primer,
 6. Field-injected silicone sealant bands.
- G. Silicone coating to be highway-grade, low-modulus, jet-fuel resistant silicone applied to the impregnated foam sealant at a width greater than maximum allowable joint extension and which when cured and compressed will form a bellows.
- H. Preformed Seals: Multicellular extruded elastomeric profiles, designed with continuous, longitudinal, internal baffles for use as primary and secondary seals complying with ASTM D2000. Formed to fit with anchored flanges, in color shown on the Contract Drawings or, if not shown, as selected by Engineer from manufacturer's standard colors.
- I. Fire Barriers
 1. Manufacturer's standard fire barrier materials for use with fire-resistant expansion joint assemblies, resisting passage of flame and hot gases through the joint without material degradation or fatigue when tested after cycling per ASTM E 1399; tested in maximum joint width condition with a field splice as a component of the expansion joint assembly per performance requirements of this Section.

2. Include manufacturer's standard fire caulks, sealants and hardware for the required hourly fire rating. Fire barrier materials shall be asbestos-free.

J. Moisture/Water Barriers: Manufacturer's standard flexible elastomeric material for use as an inner expansion joint seal: minimum 45 mils thick EPDM or minimum 30 mils thick PVC.

2.03 ACCESSORIES

A. Manufacturer's standard stainless steel anchors, fasteners, set screws, spacers, flexible vapor seal, filler materials, gutters, drain tubes, adhesives, sealants, grout, bedding materials, and other accessories compatible with material in contact, and as shown on the Contract Drawings for complete installations.

2.04 FABRICATION

A. General: Expansion joint assemblies shall be of design, basic profile, materials and operation shown on the Contract Drawings. Furnish units equal to those shown on the Contract Drawings, as required to suit joint size, to accommodate variations in adjacent surfaces and to absorb structural movement.

B. Furnish units in longest available lengths to minimize number of end joints, with hairline mitered corners where joint changes directions or abuts other materials. Include closure materials, transition pieces, tee-joints, corners, curbs, cross-connections, centering bars, pantograph mechanisms, gaskets, splice covers and other accessories as required for continuous joint assemblies.

C. Protection caps shall be stainless steel, as shown on the Contract Drawings, with surface design options as shown on the Contract Drawings. Fasten protection caps to anchor member per manufacturer's instructions, lapping each side of joint opening, permitting free movement of joint and maintaining close contact with adjacent finished surfaces.

D. Include manufacturer's continuous standard flexible moisture seals under covers at locations shown on the Contract Drawings.

E. Directional changes and terminations into vertical plane surfaces (walls, parapets, ends of decks, etc.) as well as to transition the material through curbs, treads and risers or other in-slab plane changes to be provided by factory-manufactured single units or through field fabrication in strict accordance with published installation instructions.

F. Horizontal Joint Assemblies: Furnish continuous steel reinforced elastomeric seating members of profile shown on the Contract Drawings with raised floor rim and concealed bolt and stainless steel anchors for embedment in concrete. Assemblies shall be of the design shown on the Contract Drawings and to receive abrasive-resistant filler materials, if any, for space between raised rim of seating member and edge of joint assembly. Depth and configuration shall suit type of construction and ensure that top

surface of exposed extrusions, filler material and cover plate fits flush with adjoining finish floor surface.

1. Assemblies shall be capable of resisting moisture penetration and air infiltration, as shown on the Contract Drawings.

PART 3 - EXECUTION

3.01 EXAMINATION

- A. Verify dimensions and conditions in field for Work fabricated to fit project conditions.

3.02 PREPARATION

- A. Prepare substrates according to expansion joint assembly manufacturer's instructions, including cutting, cleaning, priming, repair and surfacing.
- B. Coordinate with Work of related trades, such as for installation of items embedded in concrete or masonry.
- C. Furnish templates as required to related trades for location of embedded support and anchorage items.
- D. Repair and grout block-outs as required with manufacturer's recommended material, to provide a level support beneath side frames of floor covers and to correct oversize block-outs. Do not use shims.
- E. Fastening to In-Place Construction: Furnish and install anchorage devices and fasteners as required for securing expansion joint assemblies to in-place construction, including threaded fasteners with drilled-in expansion shields for masonry and concrete where anchoring members are not embedded in concrete. Metal fasteners shall be of the type and size required to suit type of construction shown on the Contract Drawings and to ensure secure attachment of expansion joint assemblies.

3.03 INSTALLATION

- A. Comply with manufacturer's written instructions for handling and installation of expansion joint assemblies, unless more stringent requirements are indicated.
- B. Terminate exposed ends of expansion joint assemblies with factory-fabricated termination pieces to maintain watertight integrity.
- C. Cutting Fitting and Placement: Perform cutting, drilling, patching and fitting required for installation of expansion joint assemblies. Install expansion joint assemblies in true alignment and proper relationship to adjoining finished surfaces measured from

established lines and levels. Allow adequate free movement for thermal expansion and contraction of metal to avoid buckling. Set floor assemblies, with countersunk fasteners, at elevations to be flush with adjacent finished floor materials. Locate assemblies where shown on the Contract Drawings, in continuous contact with adjacent surfaces. Attach in place securely with required accessories.

- D. Joinery and Continuity: Maintain continuity of expansion joint assemblies with end joints held to a minimum. Cut and fit ends to produce hairline joints and to produce joints that will accommodate thermal expansion and contraction of metal to avoid buckling of frames. Adhere flexible filler materials, if any, to seating member with adhesive or pressure-sensitive tape as recommended by the manufacturer.
- E. Anchorage: Anchor extrusions to adjacent substrates, continuously, at interval recommended by manufacturer, but not less than 3 inches from each end and not more than 24 inches on center. Set anchorage extrusions in continuous bed of sealant per manufacturer's recommendations; prevent slippage of vertical seal anchorages. Sealant type shall be compatible with sealants of adjacent construction.
- F. Preformed Seals: Install seals with minimum number of end joints; straight sections shall be in continuous lengths. Vulcanize or heat-weld field splice joints watertight, using manufacturer's recommended procedures. Apply manufacturer's approved adhesive, epoxy or lubricant-adhesive to both frame interfaces before installing preformed seal material. Seal transitions and end joints according to manufacturer's instructions.
- G. Seismic Seals: Install interior seal in continuous lengths. Install outer seal in standard lengths and vulcanize or heat-weld field splice joints watertight, using manufacturer's recommended procedures. Seal transitions and end joints according to manufacturer's instructions.
- H. Fire Barriers: Install fire barriers, including transitions and end joints, in accordance with manufacturer's recommended procedures so that fire-resistant construction is continuous and uninterrupted.
- I. Moisture/Water Barriers: Install water barriers and where shown on the Contract Drawings, in accordance with manufacturer's recommended procedures. Include drainage system where shown.

3.04 CLEANING

- A. Remove strippable protective material after Work in adjacent areas is complete. When protective material is removed, clean exposed metal surfaces in accordance with manufacturer's instructions.

3.05 PROTECTION

- A. Protect the installation from damage by other Work. Remove and store protective cap plates and exposed seals as required to protect from damage from construction traffic. Install temporary protection over joints and reinstall covers and seals prior to Substantial Completion.

3.06 CONTRACT CLOSEOUT

- A. Provide in accordance with Section 017700.

END OF SECTION 058100

FSECTION 061533 – DECKING

PART 1 - GENERAL

1.01 DESCRIPTION

- A. Provide decking as indicated and in compliance with Contract Documents.
 - 1. Furfurlylated Wood Decking Boards
 - 2. Douglas Fir lumber deck posts, beams, joists, sleepers for anchors, fasteners, and installation hardware as per Contract Drawings.
 - 3. Stair Nose Warning Strip
 - 4. Prototype mock-ups and on-site mock-ups

1.02 PAYMENT

- A. No separate payment shall be made for performing any Work required under this Section. All costs for Work required by this Section shall be included in the applicable Cove Park lump sum(s), as set forth in Section 012901.

1.03 RELATED SECTIONS

- A. Related Requirements:
 - 1. General Conditions Article 4.7 - Shop Drawings and other Submittals
 - 2. Section 012901 – Measurement and Payment
 - 3. Section 014300 - Quality Requirements
 - 4. Section 016100 – Control of Materials
 - 5. Section 017700 – Contract Closeout
 - 6. Section 033000 - Cast-in-Place Concrete
 - 7. Section 129300 – Site Furnishings
 - 8. Requirements from the following section also apply to this Section
 - a. Section 055001 – Site Metal Fabrications
 - b. Section 057300 - Decorative Metal Railings

- c. Section 062013 - Exterior Finish Carpentry
- d. Section 329300 – Manufacturer Site Specialties

1.04 DEFINITIONS

- A. Boards: Lumber of less than 2 inches nominal (38 mm actual) in thickness and 2 inches nominal (38 mm actual) or greater in width.
- B. Dimension Lumber: Lumber of 2 inches nominal (38 mm actual) or greater but less than 5 inches nominal (114 mm actual) in least dimension.
- C. Timber: Lumber of 5 inches nominal (114 mm actual) or greater in least dimension.
- D. Lumber grading agencies, and the abbreviations used to reference them, include the following:
 - 1. NELMA: Northeastern Lumber Manufacturers' Association.
 - 2. NLGA: National Lumber Grades Authority.

1.05 REQUIREMENTS

- A. Contractor Design: All work associated with decking is to be performed as a delegated design and build. Contractor is to provide final design, engineering, fabrication.
 - 1. General: Design and engineering of decking to be developed in accordance with building codes for structural loads and capacities.
 - 2. Contractor to provide all calculations and analysis required to complete the Work.
 - 3. Contractor is to coordinate work of others associated to features decking is adjacent or attached to, including but not limited to:
 - a. Off-shelf furnishings as per Section 129300 and per the Contract Drawings.
 - b. Custom Site Furnishings including Bench Type 1 as per the Contract Drawings.
 - c. Wall Type 2.
 - d. Shade Canopy Structures.
 - e. Resin Bound Aggregate Paving.
 - f. Cast in place concrete pathways.

- g. Unit Pavers.
 - h. Planting.
 - i. Handrails.
- B. Furnish all transportation, labor, materials and equipment to perform the following:
Furnish and install decking and accessories necessary to complete the Work.

1.06 SUBMITTALS

- A. Submit the following in accordance with General Conditions Article 4.7.
- B. Product Data: Submit manufacturer’s specifications, technical data, certifications, and installation instructions for all materials, components, accessories, and finishes of this Section including the following:
- 1. Furfurylated wood decking: Submit technical data for wood species and all applicable environmental compliance documentation, including information per 2.01 A.
 - 2. Douglas Fir-Larch framing lumber material: Submit material certificates for dimension lumber specified to confirm compliance with minimum allowable unit stresses. Indicate species and grade selected for each use and design values approved by the American Lumber Standards Committee's (ALSC) Board of Review.
 - a. A certificate, issued by an accredited laboratory, attesting to minimum design stresses, as obtained from testing of samples taken from the materials to be supplied for this work, shall accompany this statement.
 - b. Include example of identifying mark that will be exhibited on each timber piece as specified in Part 2 “Products” herein.
 - 3. For Preservative Treatment Material: Submit wood treatment data as follows, including chemical treatment manufacturer's instructions for handling, storing, installing, and finishing treated materials:
 - a. Timber Preservative Inspection: Submit the inspection report of an independent inspection agency that timber products to be used on this Project requiring preservative treatment comply with applicable AWWA Standards. Identify treatment on each piece by the quality mark of an agency accredited by the Board of Review of the American Lumber Standard Committee.

- b. Include Material Safety Data Sheets (MSDS) and Consumer Information Sheets (CIS) associated with timber preservative treatment. Contractor shall comply with all safety precautions indicated on MSDS and CIS.
 - 4. Timber/Lumber and hardwood fasteners / rough hardware, each type.
 - 5. Wood finishing, seal, and costing materials.
 - 6. Stair nose warning strip
 - C. Samples for Initial Selection:
 - 1. Wood Decking: Submit deck plank material samples showing the full range of finishes available for products specified, 24 inches long, in the thicknesses and sizes and shown on the Contract Drawings.
 - 2. Stair nose warning strip, 4 feet panel showing the finish, color and width shown on the Contract Drawings.
 - D. Shop Drawings:
 - 1. Submit manufacturing/fabrication and installation details for each component and for each area of wood decking and related support framing. Include plans, elevations, and sections to show the following as a minimum:
 - a. Relate to and show adjacent construction
 - b. Fastenings and attachments to other work
 - c. Location, layout and number of deck planks and deck plank fasteners
 - d. Final framing with interfacing to walls and grades
 - e. Edge Details
 - 2. Submit layout for mock-up/field sample installation
 - E. Quality Control Submittals:
 - 1. Delivery Inspection List(s): Field inspect and submit a verification list of each lumber member and each strapped bundle of lumber and hardwood material indicating the wording and lettering of the quality control markings, the species, and the condition of the wood.
- 1.07 QUALITY ASSURANCE
- A. Comply with the requirements specified in Section 014300.

- B. Wood Deck Installer Qualifications: Installation of wood deck systems shall be by a Company that specialized in the products specified in this Section with a minimum of three (3) years documented wood deck installation experience.
- C. Mock-Up/Field Sample for Verification
 - 1. Construct 8 feet x 8 feet minimum size mock-up/field sample of wood decking for construction procedures and for verification of deck material quality, color, thickness, and finish/end seal. Include framing, steps, stepped seating, curb rails, tree trunk openings, and other representative connection details, including fitting condition and end conditions.
 - 2. Construct mock-up/field sample as a representation of decking system with deck pattern and at a location approved by Construction Manager. Mock-up/field sample will be used as a standard for subsequent deck installation work.
 - 3. Remove mock-up/field sample at a time approved by Construction Manager.

1.08 DELIVERY, STORAGE, AND HANDLING

- A. Comply with the requirements specified in Section 016100.
- B. Delivery:
 - 1. Schedule delivery of materials at the site at such time as required for proper coordination of the work. Receive materials in manufacturer's unopened packages and bearing manufacturer's label.
 - 2. Do not incorporate materials damaged in transport from plant to site. Material shall be clean and dry, or it will be rejected due to environmental concerns.
 - 3. Inspect all preservative-treated wood, visually to ensure there are no excessive residual materials or preservative deposits.
- C. Handling:
 - 1. Handling and care of pressure treated wood shall conform to the requirements of AWWA-M4.
 - 2. Handle treated timber with ropes or chain slings without dropping, breaking outer fibers, bruising, or penetrating surface with tools. Do not use cant dogs, peaveys, hooks, or pike poles.
- D. Storage and protection:

1. Keep materials under cover and protected from weather and contact with damp or wet surfaces. Stack lumber flat with spacers between each bundle to provide air circulation. Provide for air circulation around stacks and under coverings.
2. Protect all wood material from contamination with protective coverings as recommended by the supplier.

PART 2 - PRODUCTS

2.01 MATERIALS, GENERAL

- A. Certification of furfurylated modified wood: Contractor shall be required to furnish and install lumber which has been certified by an organization accredited by the Forest Stewardship Council A.C. (FSC) as being harvested from a “well managed” forest. The material supplier shall furnish proof of their status as a company certified under the FSC guidelines.
 1. The certifying body shall be an independent third-party inspection organization accredited by the FSC such as Smart Wood, Richmond, VT (802/434-5491), Scientific Certification Systems, Oakland, CA. (510-452-8034), Advanced Certification Solutions (802-324-9651), Forest Stewardship Council - FSC Certification (763-280-1184), or approved equal. Third party certification is a mechanism to verify responsibly managed forestry operations along with a labeling system to recognize the products derived from those forests.
 2. Forest product certification involves an independent evaluation of a landowner’s forestry practices according to strict environmental and socioeconomic standards. Lumbering operations that are awarded certification may label their products as originating from a well-managed forest. Primary and secondary manufacturers who wish to sell certified wood must go through a chain of custody certification which assures consumers that the lumber originated from a certified forest.
 3. FSC Endorsed Reforestation Program: Alternatively, should FSC certified lumber not be readily available, the manufacturer shall purchase wood from a timber supplier that participates in an FSC endorsed reforestation program such as ‘Field to Forest’, Preferred by Nature (802-434-3420), Forest Stewardship Council - FSC Certification (763-280-1184), or approved equal. For every five hundred board feet (equivalent to approximately one tropical tree) of lumber consumed in the supply of this Project, eight tropical trees will be replanted and maintained by a reforestation program in an FSC endorsed well-managed forest plantation. There will be no additional payment for FSC or reforestation program participation. All costs shall be deemed included in the Contract.
- B. Provide timber and deck materials which have been selected for their surface flatness, smoothness and freedom from surface blemishes where exposed to view in the finished

unit. Provide solid sawn lumber and timbers with all four longitudinal faces free of pith and/or heartwood.

- C. All lumber and timber shall be identified by the grade mark of a recognized association or independent inspection agency using the specific grading and moisture content requirements of an association recognized as covering the species used. The association or independent inspection agency shall be certified by the Board of Review, American Lumber Standards Committee, to grade the species used.
- D. Timber and lumber sizes as shown on Contract Drawings are nominal sizes and section properties of Standard Dressed Sawn Lumber (S4S) as defined by ANSI/NfoPA-NDS-1991, National Design Specification for Wood Construction, unless noted otherwise.
 - 1. Wood members noted as (actual) shall have a net section bearing the dimensions noted on Contract Drawings, as opposed to nominal sizes.
- E. Timbers to be used in construction of all wood items shall be seasoned in order to minimize the amount of checking during and after installation. Contractor shall guarantee the wood against checking and splits for the duration of work.
- F. Fasteners and Anchors: See related Article herein.
- G. Accessory Materials and Components:
 - 1. Miscellaneous Steel Shapes: All metal hardware and hangers shall be stainless steel or hot dip galvanized as per contract drawings.

2.02 WOOD DECKING

- A. Furfurylated modified wood materials (for wood decking): Basis of Design - Provide Kebony Clear RAP boardwalk smooth (sp. Pinus radiata) supplied by Kebony US (below), Bingaman (Americana), Thermory, or approved equal:

Kebony US, 812 Riverside Ave., St. Clair, MI 48079. Tel: 855.230.5656,

E: info@kebony.us, Web: www.kebony.com

- 1. Provide deck hardwood in maximum lengths possible to suit deck configurations and conditions of application.
- 2. Decking (spp. Radiata Pine) shall have the following minimum design properties:
 - a. Grade: Clear
 - b. Wood Quality: J10 or better for 25 mm (1”) and below according to EN 942. For thickness from 25 mm (1”): J10 or better on 3 sides, J30 or better on one side.

- c. Moisture Content: 7.0% at 68 deg. F. and 65% RH.
 - d. Density at 68 deg. F., 65% RH: 37 – 42 lb. per cubic foot.
 - e. Equilibrium moisture content (EMC) at 68 deg. F., 65% RH: 5.5-6.5% determined by oven dry/ weighing method (EN13183-1).
 - f. Percent swelling from dry to 95% RH, Radial: 0.7 – 2.1.
 - g. Percent swelling from dry to 95% RH, Tangential: 2.0 – 3.7.
 - h. Percent swelling from dry to 95% RH, Longitudinal: 0.2.
 - i. Fire Class NFPA/IBC Class B, Flame Spread 45, Smoke developed 250 per ASTM E 84.
 - j. R-Value, 1” thickness: 0.96 h sq. ft deg. F/Btu.
 - k. U-value, 1” Thickness: 1.04 Btu.h sq ft. deg. F.
 - l. Stiffness E-Module: 1,800,000 psi (mean) 1,368,000 – 2,232,000 psi.
 - m. Bending strength: 9,900 psi (mean), 6,900 – 12,900 psi range. Decking boards 22 x 142 mm (7/8” x 5-9/16”) 5,200 psi.
 - n. 7/8” x 5-9/16” Span Rating, 16” o.c.: 1480 psf, 460 lbf.
 - o. 7/8” x 5-9/16” Span Rating, 24” o.c.: 430 psf, 250 lbf.
 - p. Surface Hardness: Janka Hardness 1619 lbf (ASTM D1037).
 - q. Slip Resistance, Wet: R11, assessment group A, DIN 51097.
3. Wood decking shall be solid wood milled construction without laminations.
4. All wood decking for this Project construction shall be further sorted by the producer/manufacturer to meet the following requirements:
- a. Knots – All edges and ends shall be free from knots.
 - b. Holes – Not allowed.
 - c. Ring Shake – Not allowed.
 - d. Warp (bow, cup, crook and twist) – None.
 - e. Splits and Checks – None.

- f. Wane and Bark Inclusions – Not allowed.
- g. Decay – Not allowed.
- h. All timbers shall be dense, containing not less than 6 annular rings per inch and 1/3 or more of summer wood.
- i. Moisture Content: In accordance with American Woodwork Institute (AWI), moisture content for hardwood decking material supplied to Project shall be not greater than 12 percent maximum; air-dry or kiln-dry unless otherwise shown.

B. Fabrication for Wood Decking Materials:

- 1. Mill hardwood decking units to uniform dimensions required with surfaces smooth, uniform, and without imperfections.
- 2. Cut ends shall be straight, plumb, and smooth surfaced.
- 3. Predrill holes for all connectors (bolts, lag screws, etc.).

C. Sizes:

- 1. Wood decking: Kebony clear boardwalk 1 ½” X 5 ½” actual.

2.03 WOOD DECK FRAMING

A. General: Provide dimension lumber and timber of grades indicated according to the ALSC National Grading Rule (NGR) provisions of the inspection agency indicated.

- 1. Grading: Select Structural, or better.
- 2. Moisture Content: In accordance with American Woodwork Institute (AWI) or Woodwork Institute of California (WIC), moisture content for lumber shall be not greater than 19 percent, air-dry or kiln-dry, unless otherwise noted.

B. Species for Framing: Provide solid sawn lumber and timbers of 1200f grade stress-rated Douglas Fir or approved equal. Preservative treat as specified in paragraph entitled “Preservative Treatment” of this Article.

C. All dimensional lumber (Select structural grade or better) shall have the following allowable working stress as a minimum:

- 1. Bending: 1350 psi.
- 2. Tension: 825 psi.

3. Compression parallel to grain: 1900 psi.
 4. Compression perpendicular to grain: 625 psi.
 5. Shear parallel to grain: 180psi.
 6. Modulus of Elasticity: 1,900,000 psi.
- D. Shims: Shims shall be polyethylene, Teflon, or other approved non-corrosive material with durable structural performance capabilities equal or better than the Black Locust wood performance values. Provide of profiles to suit conditions and as approved.
- E. Stand-off: Provide standoffs (As Required) at deck connections Simpson CPS4 4x4 engineer composite plastic provided by Simpson Strong-Tie, www.strongtie.com, MiTek Inc., Screw Products, Inc., Deck2Wall Spacers, or approved equal.
- F. Preservative Treatment:
1. To the extent practical and as approved by Landscape Architect, fabricate lumber and timbers before preservative treatment. Each piece of treated lumber or timber shall be branded, by the producer, in accordance with AWPA M6.
 - a. Treat wood to be used for deck framing in accordance with AWPA C2 (Saltwater Use) with water-borne preservative. Contractor shall be responsible for the quality of treated wood products.
 - b. Unless treated lumber/timber has aged at least six (6) months prior to installation, treatment shall conform to WWPI BMP to avoid leaching of preservative chemicals.
 - c. Contractor shall submit the inspection report of a Landscape Architect approved independent inspection agency, that treated products for use on this Project comply with WWPI BMP's. Materials shall be clean and dry, or it will be rejected because of environmental concerns.
 2. Furnish preservative treatment material for application in field at field cut and hole drilling and for touch up.
- G. Fabrication:
1. Holes for all connectors (bolts, lag screws, etc.) shall be pre-drilled. Timber/Lumber members receiving lag screws shall have predrilled diameter holes ready to accept the lag screws.
 2. Provide lumber and timber in longest possible lengths to suit condition of installation based on field measurements.

3. Cut, bevel, and face timbers prior to plant preservative treatment to extent possible and to minimize field cutting.
4. Cut ends shall be straight, plumb, and smooth surfaced.
5. All timber and lumber shall be delivered fully preservative treated and seal coated at cross ends with an approved sealer or transparent high-quality paraffin in order to prevent rapid loss of moisture.

2.04 FASTENERS AND ANCHORS

- A. General: Provide fasteners of size and type indicated that comply with requirements specified in this Article for material and manufacturer; to suit application as shown on Contract Drawings; and that are hot dipped galvanized complying with ASTM A153, unless otherwise noted to be stainless steel.
 1. Provide timber connectors and other metal fastenings of type and size shown. Provide with threaded lengths to allow future re-tightening.
 2. All fasteners for hardwood decking material installations shall be stainless steel, AISI Type 316.
- B. Wood Screws:
 1. General: Comply with ASME B18.61.
 2. Hardwood Deck Screws: Screws shall be 3 1/2" long, square drive, stainless steel No. 10 wood screws.
- C. Lag Bolts: Comply with ASME B18.2.1.
- D. Bolts: Steel bolts shall comply with ASTM A307, Grade A; with ASTM A563 hex nuts and, where indicated, flat washers.
- E. Carriage Bolts: Round Head with Square neck, complying with ASME B 18.5.

2.05 STAIR NOSE WARNING STRIP

- A. General: Provide prefabricated highlighted, slip resistant, class 1 flame spread non-sparking, non-metallic, fiberglass stair nosing, complying with ISO 9001:
 1. Slip resistant levels using Pendulum test method (Four @ rubber slider/96 slider):
Dry reading: 80/ Wet reading: 75
 2. General use: Standard pedestrian Traffic
 3. Top Finish: Carbon and Silicon Grip Top surface

4. Color: Black
5. Thickness: 0.16” thick nominal
6. Design Life: 10+ years
7. Service temperatures: -4-degrees F to +176-degrees F

B. Product:

1. Basis of Design – Dino Grip Stair Nosing as supplied by:
 - a. Dino Grip, 576 Ocoee Business Parkway, Suite 100, Ocoee, Florida; tel. 888-341-0060; email. info@dinogrip.com
 - b. Tredsafe Company
 - c. Sure-Foot Industries Corp.
2. Or approved equal.

PART 3 - EXECUTION

3.01 EXAMINATION

- A. Verification of conditions: examine conditions of work in place before beginning work; report defects to the Construction Manager.
- B. Measurements: Take field measurements; report variance between Contract Drawings and field dimensions to the Construction Manager.

3.02 PREPARATION

- A. Coordination: relate to and arrange hardwood decking installation together with concrete float construction, gangway components, retaining wall type 2, and under deck installed items including power conduit, shade canopy footings, and drainage features.
- B. Provide protective equipment for personnel fabricating, field treating, or handling materials treated with preservatives. Comply with applicable "MSDS and CIS" requirements.

3.03 INSTALLATION, GENERAL

- A. General: install in conformance with referenced standards, manufacturer's written directions, as shown, and as specified.

- B. Cut and frame lumber and timber so that joints will fit over contact surface with even bearing without shimming. Secure in alignment. Open joints are not acceptable.
- C. Boring Holes:
 - 1. Bore holes for drift pins and dowels with a bit 1/16 inch less in diameter than the pin or dowel used.
 - 2. Bore holes for bolts with a bit 1/16 inch larger in diameter than rod or bolt used.
 - 3. Bore holes for lag screws in two parts. Make lead hole for shank the same diameter as shank. Make lead hole for the threaded portion approximately two-thirds of the shank diameter.
 - 4. Bore holes in small timbers for boat or wire spikes with a bit of the same diameter or smallest dimension of the spike to prevent splitting.
 - 5. Holes to receive timber fasteners shall be counterbored so as not to cause timber to crack or split when fastenings are installed.
 - 6. Counterbore for countersinking wherever smooth faces are indicated or specified.
- D. Anchors into concrete shall be stainless steel adhesive anchor bolts. Clearly identify type and location for each condition on shop drawings submitted.
- E. Apply field treatment complying with AWPAC M4 to cut surfaces of preservative-treated lumber. Refer to Article “Field Treatments” herein for additional provisions.

3.04 WOOD DECK FRAMING

- A. Discard units of material with defects that impair quality of deck system installation and that are too small to use with minimum number of joints or optimum joint arrangement.
- B. Set timber to required levels and lines, with members plumb, true to line, cut, and fitted.
- C. Adhesive-bonded Anchors (For securing anchor bolts to concrete): Comply with anchor manufacturer’s written instructions. Do not install anchors when air or substrate temperatures are below manufacturer’s recommendations. Embed anchors sufficiently into concrete to develop the full tensile strength of the bolt with embedment depth as indicated.
- D. Fit framing to other construction; scribe and cope as required for accurate fit. Correlate location of nailers, blocking, grounds, and similar supports to allow attachment of other construction.
- E. Joists For Wood Decking:

1. Install joists with connection to stand-offs, and if required by conditions as approved by Landscape Architect, shim to provide level wood decking surface specified.
2. Confirm level condition and retighten all anchors to provide firm and secure installation for wood decking planks.
3. After bolt retightening, if necessary, cut anchor bolt head so that heads are flush with or below top surface of joists.
4. Fill recess around top surface counterboring to prevent water collection. Refer to Article “Field Treatments” herein for additional provisions.
5. General: install in conformance with referenced standards, manufacturer's written directions, as shown, and as specified.

3.05 WOOD DECKING

- A. Prior to installation of decking, each bay shall be checked for leveling with a straight edge. Contractor shall do all necessary shimming and trimming of high spots at no additional cost to the DEP.
- B. Decking Installation:
 1. Lay deck plank in the directions shown and with consistent and uniform spacing between the deck planks of ¼ inch minimum and, except where noted otherwise on the Contract Drawings, ½ inch maximum.
 - a. Make decking of a single thickness of deck plank supported by joists.
 - b. Grade deck planks as to thickness and lay so that adjacent planks vary less than 1/16 inch.
 - c. Butt ends to adjacent timber, deck, or other condition shall be square.
 2. Cutting, Fitting, and Placement:
 - a. Perform cutting, drilling, and fitting required for installing decking. Cut ends of deck planks parallel to edge.
 - b. Secure each deck plank to each joist or nailing strip with at least two stainless steel countersunk tamper proof screws set within pre-drilled holes. Place screws at least 2-1/2 inches from edges of the deck plank.
 - c. The hole for screws shall be 1/16 inch diameter smaller than screw diameter. All screws shall be countersunk 1/16 inch.

- d. Decking shall not be glued or laminated.
- e. Comply with decking manufacturer's additional written installation instruction.

3.06 FIELD TREATMENTS

- A. Timberwork: field treat cuts, bevels, notches, refacing and abrasions made in the field in preservative treated timbers in accordance with AWPA M4, MSDS and CIS. Wood preservatives are restricted-use pesticides and shall be applied according to applicable standards.
 - 1. Trim cuts and abrasions before field treatment.
 - 2. Coat depressions or openings around bolt holes, joints, joists, or gaps including recesses formed by counterboring with preservative treatment used for timber.
 - 3. After field treatment and after bolt or screw is in place fill depressions and openings with hot pitch or a bitumastic compound.
- B. Galvanized Surfaces: Repair and recoat zinc coating which has been field or shop cut, burned by welding, abraded, or otherwise damaged to such an extent as to expose the base metal.
 - 1. Thoroughly clean the damaged area by wire brushing and remove traces of welding flux and loose or cracked zinc coating prior to painting.
 - 2. Compound paint with a suitable vehicle in a ratio of one part zinc oxide to four parts zinc dust by weight.
 - 3. Paint cleaned area with two coats of zinc oxide-zinc dust paint conforming to MIL-P-21035. Allow each coat to correctly dry between coats.

3.07 STAIR NOSE WARNING STRIP

- A. Preparation:
 - 1. The stairs should be dry and clean and free from any loose and defective material. If there are areas that are damaged these should be repaired so that the surface is flat and even.
 - 2. Undertake a dry fit of the nosing to ensure that it sits flat and is the correct size. If any further trimming is required, we recommend the use of a jigsaw, preferably fitted with a tungsten carbide blade or hand grinder.
 - 3. Drill two holes at approx. 600mm from the center

B. Fitting:

1. To lay the stair nosings upon the surface and then use a 6mm masonry drill bit to drill the top of the gritted surface in the desired fixing locations, at approximately 8 fixings per 1 meter of stair nosing.
2. Once the pilot holes have been drilled to then screw into position using the flanged stainless steel screws. Additional adhesive can be used (if require) to add extra grip to the underneath the stair nosing.

3.08 ADJUSTING

- A. Restore finishes damaged during installation and construction period so no evidence remains of corrective work. Return items that cannot be refinished in the field to the shop; make required alterations and refinish entire unit or provide new units.

3.08 CONTRACT CLOSEOUT

- A. Provide in accordance with Section 017700.

END OF SECTION 061533

SECTION 062013 – EXTERIOR FINISH CARPENTRY

PART 1 - GENERAL

1.01 DESCRIPTION

- A. Provide exterior finish carpentry as indicated and in compliance with Contract Documents. Exterior finish carpentry elements are a delegated design item as per Paragraph 1.06 B herein and Section 323900.
 - 1. Wood Bench Boards for:
 - a. Bench Type 1
 - b. Barstool Seating
 - c. Wood Seat Tops at Plaza Planters
 - d. Entry Signage
 - e. Amphitheater Wood Top Seating

1.02 PAYMENT

- A. No separate payment shall be made for performing any Work required under this Section. All costs for Work required by this Section shall be included in the applicable lump sum(s), as set forth in Section 012901.

1.03 REFERENCES

- A. ALSC – American Lumber Standard Committee
- B. AWPA – American Wood Preservers' Association
 - 1. C1 – All Timber Products – Preservative Treatment by Pressure Processes
 - 2. C2 – Lumber, Timber, Bridge Ties, and Mine Ties – Preservative Treatment by Pressure Processes.
- C. FSC – Forest Stewardship Council

1.04 RELATED SECTIONS

- A. General Conditions Article 4.7 – Shop Drawings and Other Submittals
- B. Section 012901 – Measurement and Payment

- C. Section 014300 – Quality Requirements
- D. Section 016100 – Control of Materials
- E. Section 017700 – Contract Closeout
- F. Section 323900 - Manufactured Site Specialties
- G. Section 329700 – Landscape Maintenance
- H. Requirements from the following section also apply to this Section
 - 1. Section 033000 – Cast-In-Place Concrete
 - 2. Section 034500 – Site Precast Architectural Concrete
 - 3. Section 055001 – Site Metal Fabrications
 - 4. Section 061533 - Decking

1.05 DEFINITIONS

- A. Acceptance, Acceptable, or Accepted: Acceptance by the Architect/Engineer.
- B. Well Managed: Meeting the forest management standards endorsed by the FSC.

1.06 REQUIREMENTS

- A. Provide all fabrications (or listed elements) are under the requirements of a coordinated fabrication as outlined under Section 329200 – Manufactured Site Specialties. All design and fabrication to be fully coordinated during review, fabrication, assembly, and installation.
- B. Contractor Design: All work associated with elements in this Section is to be performed as a delegated design and build. Contractor is to provide final design, engineering, fabrication.
 - 1. General: Design and engineering of bench type 1, barstool seating, wood seat tops at plaza planters, entry signage, and amphitheater wood top seating elements to be developed in accordance with building codes for structural loads and capacities.
 - 2. Contractor to provide all calculations and analysis necessary to complete the Work.
 - 3. Contractor is to coordinate work of others associated with or attached to features in this Section including but not limited to:
 - a. Precast architectural concrete stairs.

- b. Retaining walls.
 - c. Cast in place concrete pathways.
 - d. Resin bound aggregate paving.
 - e. Unit pavers.
 - f. Planting.
 - g. Decking.
 - h. Resist Structure.
 - i. LED Lighting.
- C. Furnish all transportation, labor, materials and equipment to perform the following: Furnish and install features in this Section and accessories necessary to complete the Work.

1.07 SUBMITTALS

- A. Submit the following in accordance with General Conditions Article 4.7.
- B. Product Data: Submit manufacturer's specifications, technical data, certifications, and installation instructions for all materials, components, accessories, and finishes of this Section including the following:
- 1. Furfurylated Wood Boards: Submit technical data for wood species and all applicable environmental compliance documentation, including information per paragraph 2.01 A.
 - 2. Fasteners.
- C. Samples for Verification:
- 1. Two 1.5" x 3.5" x 18" long bench board members, in finish indicated.
- D. Shop Drawings: Prepare project specific information, drawn accurately to scale. Submit large scale dimensioned drawings, showing detail fabrication and installation of each element indicated in the drawings. Indicate locations, plans, elevations, dimensions, shapes, and cross sections. Do not base Shop Drawings on reproductions of the Contract Documents or standard printed data. Shop Drawings are to be coordinated with all relevant, related and adjacent components, in accordance with Section 323900.
- 1. Preparation: Fully illustrate requirements in the Contract Documents. Include the following information, as applicable:

- a. Identification of all products used in fabrication(s).
 - b. Indicate jointing, reveals, patterns, and extent and location of each surface finishes.
 - c. Schedules of parts, fabrication pieces, hardware, anchors, fasteners and finishes.
 - d. Indicate welded connections by AWS standard symbols in accordance with Section 055001.
 - e. Indicate locations, tolerances, and details of anchorage devices to be embedded in or attached to structure or other construction.
 - f. Compliance with specified standards and codes.
 - g. Notations of coordination requirements and sequencing of work.
 - h. Field verification and notation of dimensions based established upon actual field conditions and adjacent structures. Where items must fit and coordinate with finished surfaces and/or constructed spaces, take measurements at the site and not from drawings.
 - i. Relationship and attachment to adjoining construction clearly indicated.
 - j. Fully fabricated unit(s). Drawings to show work by multiple trades in a single drawing set to assure coordination of work.
 - k. Seal and signature of a professional engineer if specified. Structural drawings and calculations prepared and signed by a licensed engineer registered in the State of New Jersey.
 - l. Provide templates for other fabricator use and installation work.
2. Shop drawings shall be fully coordinated with all conditions, showing adjacent work, and be combined into one package in accordance with Section 323900 to provide:
- a. 1/4" = 1'-0" for all elevation and plans views for carpentry and metal work items showing layout and conditions of the site. The drawings will provide field confirmation of conditions of the site.
 - b. 1" = 1'-0" larger elevation views of all carpentry and metal work locations.
 - c. 1 1/2" = 1'-0" and 3" = 1'-0" for all details depicting fasteners, connections and small fabrication elements.

3. Submit shop drawings for the following items:
 - a. Wood Bench Boards for Bench Type 1 as a unit with metal mounting components.
 - b. Wood Bench Boards for Barstool Seating as a unit with metal mounting components.
 - c. Wood Bench Boards for Wood Seat Tops at Plaza Planters as a unit with metal mounting components.
 - d. Wood Bench Boards for Amphitheater Wood Top Seating as a unit with metal mounting components.
 - e. Wood Boards for Entry Signage as a unit with metal mounting components.

E. Certificates of metal and welding in accordance with Section 055001.

1.08 QUALITY ASSURANCE

- A. Comply with the requirements specified in Section 014300.
- B. Furfurylated Wood Boards: Submit documentation confirming the boards are from well-managed forests for acceptance prior to purchase.
- C. Workmanship: Perform work in accordance with the best standards of practice using workers experienced in the type of work specified.
- D. Wood Bench Boards Shop Drawings:
 1. Submit Shop Drawings of Wood Bench Boards in accordance with requirements of Section 055001 for acceptance prior to construction.
 2. Furnish accepted Shop Drawings to the trades responsible for installing any connectors or inserts.
- E. Delivery of Fabricated Units: Modularized fabricated components to be delivered as a unit with metal work and other components in accordance with Section 323900.
- F. Mock-ups:
 1. Provide as per Section 323900.

1.09 PRODUCT DELIVERY AND STORAGE

- A. Comply with the requirements of Section 016100.

- B. Delivery: Protect all materials from damage, soiling, and accumulation of moisture during delivery.
- C. Storage:
 - 1. Store lumber to ensure proper ventilation and drainage; protect from rain and other damage.
 - 2. Keep boards out of sunlight until installed.
 - 3. Acclimate wood to local moisture levels by stacking boards on lath, or other separators of uniform thickness, to expose both faces to air immediately upon delivery.

1.10 CLOSEOUT SUBMITTALS

- A. Maintenance Data: For site furnishings to include in maintenance manuals.

1.11 WARRANTY

- A. General Description: In addition to manufacturer’s warranties, warrant Work for a period of one year from the date of Substantial Completion for the entire Project against defects in materials and workmanship.
- B. Additional Items Covered: Warranty shall also cover repair of damage to other materials and workmanship resulting from defects in materials and workmanship.

PART 2 - PRODUCTS

2.01 MATERIALS, GENERAL

- A. Certification of furfurylated modified wood: Contractor shall be required to furnish and install lumber which has been certified by an organization accredited by the Forest Stewardship Council A.C. (FSC) as being harvested from a “well managed” forest. The material supplier shall furnish proof of their status as a company certified under the FSC guidelines.
 - 1. The certifying body shall be an independent third-party inspection organization accredited by the FSC such as Scientific Certification Systems (SCS), Preferred by Nature (802-434-3420), Forest Stewardship Council - FSC Certification (763-280-1184), or approved equal. Third party certification is a mechanism to verify responsibly managed forestry operations along with a labeling system to recognize the products derived from those forests.
 - 2. Forest product certification involves an independent evaluation of a landowner’s forestry practices according to strict environmental and socioeconomic standards.

Lumbering operations that are awarded certification may label their products as originating from a well-managed forest. Primary and secondary manufacturers who wish to sell certified wood must go through a chain of custody certification which assures consumers that the lumber originated from a certified forest.

3. FSC Endorsed Reforestation Program: Alternatively, should FSC certified lumber not be readily available, the manufacturer shall purchase wood from a timber supplier that participates in an FSC endorsed reforestation program such as 'Field to Forest', Preferred by Nature (802-434-3420), Forest Stewardship Council- FSC Certification (763-280-1184), or approved equal. For every five hundred board feet (equivalent to approximately one tropical tree) of lumber consumed in the supply of this Project, eight tropical trees will be replanted and maintained by a reforestation program in an FSC endorsed well-managed forest plantation. There will be no additional payment for FSC or reforestation program participation. All costs shall be deemed included in the Contract.
- B. Provide wood board materials which have been selected for their surface flatness, smoothness and freedom from surface blemishes where exposed to view in the finished unit. Provide solid sawn lumber with all four longitudinal faces free of pith and/or heartwood.
 - C. All lumber shall be identified by the grade mark of a recognized association or independent inspection agency using the specific grading and moisture content requirements of an association recognized as covering the species used. The association or independent inspection agency shall be certified by the Board of Review, American Lumber Standards Committee, to grade the species used.
 - D. Lumber sizes as shown on Contract Drawings are nominal sizes and section properties of Standard Dressed Sawn Lumber (S4S) as defined by ANSI/NfoPA-NDS-1991, National Design Specification for Wood Construction, unless noted otherwise.
 1. Wood members noted as (actual) shall have a net section bearing the dimensions noted on Contract Drawings, as opposed to nominal sizes.
 - E. Lumber to be used in construction of all wood items shall be seasoned in order to minimize the amount of checking during and after installation. Contractor shall guarantee the wood against checking and splits for the duration of work.
 - F. Fasteners and Anchors: See related Article herein.
 - G. Accessory Materials and Components:
 1. Miscellaneous Steel Shapes: All metal hardware and hangers shall be stainless steel Type 316L.

2.02 WOOD BOARDS FOR BENCH TYPE 2, BARSTOOL SEATING, WOOD SEAT TOPS AT PLAZA PLANTERS, ENTRY SIGNAGE, AND AMPHITHEATER WOOD TOP SEATING

A. General:

1. Do not mark or color lumber, except where such marking will be concealed in finish work.
2. Except as otherwise specified, lumber shall be vertical grain. If not available, the product shall be individually selected to assure a Clear Grade (no knots), as little “white” wood as possible, and a fine growth ring.
3. No finger jointed, twisted, warped, bowed, or otherwise, defective lumber wood will be allowed.
4. Sizes indicated are nominal, unless otherwise indicated.
5. Do not use twisted, warped, bowed, or otherwise defective lumber.
6. Boards shall be individually mill-preselected for straightness. Bowed or cupped boards are not acceptable.
7. In addition to straightness, boards shall be individually mill-preselected for appearance match and to provide an overall uniformity to the lumber and avoid noticeable appearance differences between adjacent pieces.
8. Attachment to be made with concealed fasteners. Countersink and plug unavoidable exposed screws.

B. Treated Bench Boards: Provide the following wood type for the fabrication of all bench boards.

1. Furfurylated modified wood materials (for wood decking): Basis of Design - Provide Kebony Clear RAP boardwalk smooth (sp. Pinus radiata) supplied by Kebony US (below), Bingaman (Americana), Thermory, or approved equal:

Kebony US, 812 Riverside Ave., St. Clair, MI 48079. Tel: 855.230.5656,

E: info@kebony.us, Web: www.kebony.com

- a. Provide deck hardwood in maximum lengths possible to suit deck configurations and conditions of application.
- b. Decking (spp. Radiata Pine) shall have the following minimum design properties:

- 1) Grade: Clear
 - 2) Wood Quality: J10 or better for 25 mm (1”) and below according to EN 942. For thickness from 25 mm (1”): J10 or better on 3 sides, J30 or better on one side.
 - 3) Moisture Content: 7.0% at 68 deg. F. and 65% RH.
 - 4) Density at 68 deg. F., 65% RH: 37 – 42 lb. per cubic foot.
 - 5) Equilibrium moisture content (EMC) at 68 deg. F., 65% RH: 5.5-6.5% determined by oven dry/ weighing method (EN13183-1).
 - 6) Percent swelling from dry to 95% RH, Radial: 0.7 – 2.1.
 - 7) Percent swelling from dry to 95% RH, Tangential: 2.0 – 3.7.
 - 8) Percent swelling from dry to 95% RH, Longitudinal: 0.2.
 - 9) Fire Class NFPA/IBC Class B, Flame Spread 45, Smoke developed 250 per ASTM E 84.
 - 10) R-Value, 1” thickness: 0.96 h sq. ft deg. F/Btu.
 - 11) U-value, 1” Thickness: 1.04 Btu.h sq ft. deg. F.
 - 12) Stiffness E-Module: 1,800,000 psi (mean) 1,368,000 – 2,232,000 psi.
 - 13) Bending strength: 9,900 psi (mean), 6,900 – 12,900 psi range. Decking boards 22 x 142 mm (7/8” x 5-9/16”) 5,200 psi.
 - 14) 7/8” x 5-9/16” Span Rating, 16” o.c.: 1480 psf, 460 lbf.
 - 15) 7/8” x 5-9/16” Span Rating, 24” o.c.: 430 psf, 250 lbf.
 - 16) Surface Hardness: Janka Hardness 1619 lbf (ASTM D1037).
 - 17) Slip Resistance, Wet: R11, assessment group A, DIN 51097.
- c. Wood decking shall be solid wood milled construction without laminations.
- d. All wood decking for this Project construction shall be further sorted by the producer/manufacturer to meet the following requirements:
- 1) Knots – All edges and ends shall be free from knots.
 - 2) Holes – Not allowed.

- 3) Ring Shake – Not allowed.
 - 4) Warp (bow, cup, crook and twist) – None.
 - 5) Splits and Checks – None.
 - 6) Wane and Bark Inclusions – Not allowed.
 - 7) Decay – Not allowed.
 - 8) All timbers shall be dense, containing not less than 6 annular rings per inch and 1/3 or more of summer wood.
 - 9) Moisture Content: In accordance with American Woodwork Institute (AWI) , moisture content for hardwood decking material supplied to Project shall be not greater than 12 percent maximum; air-dry or kiln-dry unless otherwise shown.
2. Wood to be provided from forests that are certified “well managed by an FSC-accredited agency” as per Paragraph 2.01 A herein.
 3. Select grade, all heartwood, clear on one face and two edges, no sapwood.
 4. Milled to sizes as indicated in the drawings, plus or minus 1/32-inch.
 5. Finish: Kebony Clear, By Kebony US, Bingaman (Americana), Thermory USA, or approved equal.

2.03 MISCELLANEOUS ACCESSORIES

A. Fasteners

1. General: Provide 316L stainless steel fasteners connections.
 - a. All exposed fasteners to be architectural quality, installed countersunk and flush to surface. All fasteners exposed to public access shall be tamper resistant.

B. Electrodes for Welding: In accordance with AWS Code.

2.04 FABRICATION ELEMENTS

A. Schedule of Fabricated Elements

Fabricated Element	Refer to Contract Documents:	Finish and Color
Bench Type 1 (Delegated Design Item)		
Furfurylated wood slats and mounting elements in configuration and sizes as shown on Contract Documents.	CPL013, CPL940	Refer to Furnishings Schedule, CPL013
Barstool Seating (Delegated Design Item)		
Furfurylated wood slats and mounting elements in configuration and sizes as shown on Contract Documents.	CPL013, CPL941	Refer to Furnishings Schedule, CPL013
Wood Seat Tops at Plaza Planter (Delegated Design Item)		
Furfurylated wood slat modules and mounting elements for Large Plaza Planter, Small Plaza Planter Type A, and Small Plaza Planter Type B in configuration and sizes as shown on Contract Documents.	CPL013, CPL930, CPL931, CPL932, CPL933, CPL934.1, CPL934.2, CPL934.3	Refer to Furnishings Schedule, CPL013
Amphitheater Wood Top Seating (Delegated Design Item)		
Furfurylated wood slats and mounting elements in configuration and sizes as shown on Contract Documents.	CPL918.1, CPL918.2	Kebony Clear by Kebony US, Bingaman (Americana), Thermory, or approved equal
Entry Signage (Delegated Design Item)		
Furfurylated wood slats and mounting elements in configuration and sizes as shown on Contract Documents.	CPL980, CPL981, CPL982, CPL983	Kebony Clear by Kebony US, Bingaman (Americana), Thermory, or approved equal

PART 3 - EXECUTION

3.01 EXAMINATION

- A. Examine areas and conditions, with Installer and Construction Manager present, for compliance with requirements for correct and level finished grade, mounting surfaces, installation tolerances, and other conditions affecting performance of the Work.
- B. Proceed with installation only after unsatisfactory conditions have been corrected.

3.02 INSTALLATION

- A. Comply with manufacturer's written installation instructions unless more stringent requirements are indicated. Complete field assembly of site furnishings where required.
- B. Unless otherwise indicated, install site furnishings after landscaping and paving have been completed.
- C. Install site furnishings level, plumb, true, and securely anchored at locations indicated on the Contract Drawings.
- D. Wood Boards:
 - 1. Cutting
 - a. Cut wood cleanly with sharp carbide-tipped blades.
 - b. Sand rough and splintered board edges smooth.
 - 2. Installation:
 - a. Prior to installing screws, drill pilot holes to diameter recommended by the screw manufacturer to prevent splitting of boards.
 - b. Boards requiring straightening shall be clamped in the desired position until properly fastened.
 - c. Install boards in directions indicated on the Contract Drawings and approved Shop Drawings.
 - d. Install boards with center lines equally spaced as shown in the drawings.
 - e. Install side of board with best appearance up.
 - f. Fasten boards with approved fasteners and wood screws. All fasteners and wood screws are to be concealed from view except at critical connections.

- g. The fabrication of wood units is to be designed in manner of a fabricated unit including woodwork and supporting framing.

3.03 TOLERANCES

A. Bench Boards:

1. Maximum variation from Cross Sectional: 1/8-inch.
2. Maximum Variation of Front Top Corners from a straight line: 1/16-inch.
3. Variation of Visible Board Screw Heads from Flush with Board Surface: 0 inches beyond board face to 1/32-inch into board.

3.04 CLEANING

- A. Remove soil and foreign matter from furnishing and keep clean until the DEP accepts the landscape maintenance period per Section 329700.

3.05 PROTECTION

- A. Protect Bench Boards from damage and staining by covering with tarp or fabric until Final Completion.
- B. Do not allow equipment or material storage or staging on bench boards

3.06 CONTRACT CLOSEOUT

- A. Provide in accordance with Section 017700.

END OF SECTION 062013

NO TEXT ON THIS PAGE

SECTION 071416 - COLD FLUID-APPLIED WATERPROOFING

PART 1 - GENERAL

1.01 SUMMARY

- A. This Section specifies cold fluid-applied reinforced unsaturated polyester roofing system, for the Shade Canopy roof, including non-slip topcoat, sheathing, all related flashings, and termination bars. This Section specifies the roofing system as installed over non-combustible exterior sheathing on deck where shown on the Contract Drawings.
- B. This Section also specifies two component polyurethane bituminous liquid applied waterproofing for below grade application at the retaining walls.

1.02 PAYMENT

- A. No separate payment shall be made for performing any Work required under this Section. All costs for Work required by this Section shall be included in the applicable Cove Park lump sum(s) as set forth in Section 012901.

1.03 RELATED SECTIONS

- A. General Conditions Article 4.7 – Shop Drawings and Other Submittals
- B. Section 012901 – Measurement and Payment
- C. Section 014300 – Quality Requirements
- D. Section 017700 – Contract Closeout
- E. Section 079200 – Sealants
- F. Requirements from the following section also apply to this Section
 - 1. Section 057500 – Decorative Formed Metal

1.04 SUBMITTALS

- A. Submit the following items in accordance with General Conditions Article 4.7.
- B. Product Data: For type of product indicated.

- C. Shop Drawings: Show locations and extent of waterproofing. Include details for substrate joints and cracks, sheet flashings, penetrations, inside and outside corners, tie-ins with adjoining waterproofing, and other termination conditions.
- D. Product test reports.

1.05 QUALITY ASSURANCE

- A. Comply with Section 014300.
- B. Installer Qualifications: A firm that is licensed by waterproofing manufacturer for installation of waterproofing required for this Project.
- C. Preinstallation Conference: Conduct conference at Project site.
 - 1. Review waterproofing requirements including surface preparation, substrate condition and pretreatment, minimum curing period, forecasted weather conditions, special details and flashings, installation procedures, testing and inspection procedures, and protection and repairs.
- D. Source Limitations: Obtain cold fluid-applied reinforced unsaturated polyester roofing system products from a single manufacturer.
- E. Testing Responsibility: Contractor shall engage a qualified testing agency to perform testing and to interpret test results of the cold fluid-applied reinforced unsaturated polyester roofing systems roofing materials to comply with requirements of the specifications, and requisite for the Manufacturer's Warranty.
- F. The DEP may contract the services of an independent agency to perform inspections on the roofing systems. The Contractor shall cooperate with the inspectors and provide safe access to inspect the work.

1.06 PROJECT CONDITIONS

- A. Environmental Limitations: Apply waterproofing within the range of ambient and substrate temperatures recommended by waterproofing manufacturer. Do not apply waterproofing to a damp or wet substrate, when relative humidity exceeds 85 percent, or when temperatures are less than 5 degrees F above dew point.

1.07 WARRANTY

- A. Special Manufacturer's Warranty: Manufacturer's standard form in which waterproofing manufacturer and Installer agree to repair or replace waterproofing that does not comply with requirements or that fails to remain watertight within specified warranty period.

1. Warranty Period: Five years from date of Substantial Completion.

PART 2 - PRODUCTS

2.01 SINGLE-COMPONENT POLYURETHANE WATERPROOFING

- A. Single-Component, Modified Polyurethane Waterproofing: Comply with ASTM C 836 and with manufacturer's written physical requirements.
 1. Products: Subject to compliance with all requirements, provide one of the following available products that may be incorporated into the Work include, but are not limited to, the following:
 - a. Kemperol Fluid-Applied Roofing, as manufactured by Kemco Kemper System, Inc.
 - b. Tremco CR360/CP930 Repoma, as manufactured by Tremco Incorporated.
 - c. Triflex Gmbh & Co.
 - d. Karnak Corporation; One-Kote System.
 - e. Or approved equal.
- B. Two-Component, Polyurethane Bituminous Liquid Applied Waterproofing: Comply with manufacturer's written physical requirements.
 1. Products: Subject to compliance with all requirements, provide one of the following available products that may be incorporated into the Work include, but are not limited to, the following:
 - a. Sikagard 62, as manufactured by Sika USA, ISOMAT PU Systems, ICR Solutions, Inc.
 - b. Or approved equal.

2.02 AUXILIARY MATERIALS

- A. Primer: Manufacturer's standard, factory-formulated polyurethane or epoxy primer.
- B. Sheet Flashing: 50-mil- minimum, non-staining, uncured sheet neoprene, coating color to match fluid-applied roofing.
 1. Adhesive: Manufacturer's recommended contact adhesive.

- C. Membrane-Reinforcing Fabric: Cold fluid-applied reinforced unsaturated polyester membrane with a 360-degree needle punched non-woven polyester reinforced fleece, for a finished dry film membrane thickness of 0.080-inch nominal per ply; anti-slip topcoat surfacing as selected by the Architect/Engineer from manufacturer's standard palette of "White" colors; confirming to ASTM C 836. Thickness does not include anti-slip topcoat surfacing. Subject to compliance with requirements, provide products manufactured and supplied by the following:
1. Kemperol Fluid-Applied Roofing, as manufactured by Kemco Kemper System, Inc. and made up of the following components:
 - a. Primer: A two-component, solvent-free, high solids, polyurethane primer.
 - b. Resin: Kemperol V210 Resin, multi-component, elastomeric, unsaturated polyester resin.
 - c. Fleece: Kemperol Fleece 200 polyester fleece reinforcement.
 2. Triflex Fluid-Applied Roofing Systems as manufactured by Triflex Ltd. Gmbh & Co. and made up of the following:
 - a. Primer: A two-component, solvent-free, high solids, PMMA Primer.
 - b. Resin Triflex D or Protect Resin, a two-component, elastomeric, unsaturated polyester resin.
 - c. Fleece: Triflex 110g polyester fleece reinforcement.
 3. Roofing manufactured by W.R. Meadows
 4. Or approved equal.
- D. Joint Reinforcing Strip: Manufacturer's recommended fiberglass mesh or polyester fabric.
- E. Silica sand shall be washed, kiln-dried, and dust-free, furnished in the following size range: 0.45 to 0.55 mm sand.
- F. Type ES-1, as specified in Section 079200.
1. Sealant coming in contact with any component of the roofing system shall be installed in strict compliance with the published instructions of the manufacturer.
- G. Water Cutoff Mastic: Manufacturer's standard butyl mastic sealant.

- H. Provide and Install Sheathing Type per waterproofing manufacturer's specification requirement over metal decking.

PART 3 - EXECUTION

3.01 SURFACE PREPARATION

- A. Clean and prepare substrate according to manufacturer's written recommendations. Provide clean, dust-free, and dry substrate for waterproofing application.
- B. Mask off adjoining surfaces not receiving waterproofing to prevent spillage or overspray affecting other construction.
- C. Close off deck drains and other deck penetrations to prevent spillage and migration of waterproofing fluids.
- D. Remove grease, oil, bitumen, form-release agents, paints, curing compounds, acid residues, and other penetrating contaminants or film-forming coatings from concrete.
- E. Remove fins, ridges, and other projections and fill honeycomb, aggregate pockets, and other voids.
- F. Prepare vertical and horizontal surfaces at terminations and penetrations through waterproofing and at expansion joints, drains, and sleeves according to ASTM C 898 and manufacturer's written instructions.
 - 1. Apply waterproofing in two separate applications and embed a joint reinforcing strip in the first preparation coat when recommended by waterproofing manufacturer.
- G. Prepare, treat, rout, and fill joints and cracks in substrate according to ASTM C 898 and waterproofing manufacturer's written instructions. Remove dust and dirt from joints and cracks, complying with ASTM D 4258, before coating surfaces.
- H. Install sheet flashing and bond to deck and wall substrates where indicated or required according to waterproofing manufacturer's written instructions.
 - 1. Extend sheet flashings onto perpendicular surfaces and other work penetrating substrate according to ASTM C 898.

3.02 WATERPROOFING APPLICATION

- A. Apply waterproofing according to ASTM C 898 and manufacturer's written instructions.
- B. Reinforced Waterproofing Applications:

1. Apply first coat of waterproofing, embed membrane-reinforcing fabric, and apply second coat of waterproofing to completely saturate reinforcing fabric and to obtain a seamless reinforced membrane free of entrapped gases, with an average dry film total thickness of 80 mils.

C. Anti-Slip topcoat Surfacing:

1. Where anti-slip topcoat surfacing is shown on the Contract Drawings or where required for compliance with requirements of this Section, liberally sprinkle the surface (after topcoat application) with silica sand and cover with an additional topping coat, in color selected by Architect/Engineer.

3.03 CURING, PROTECTION, AND CLEANING

- A. Cure waterproofing according to manufacturer's written recommendations, taking care to prevent contamination and damage during application stages and curing.
 1. Do not permit foot traffic on unprotected membrane.
- B. Protect waterproofing from damage and wear during remainder of construction period.
- C. Clean spillage and soiling from adjacent construction using cleaning agents and procedures recommended by manufacturer of affected construction.

3.04 CONTRACT CLOSEOUT

- A. Provide in accordance with Section 017700.

END OF SECTION 071416

SECTION 074213 - METAL COMPOSITE MATERIAL PANELS

PART 1 - GENERAL

1.01 DESCRIPTION

- A. Provide Metal Composite Material Panels as specified and as shown on Contract Documents.
- B. The Work of this Section includes all labor, materials, equipment, and services necessary to complete the metal composite material panels and installation on pedestrian bridge soffit as shown on the Contract Drawings and Contract Sections herein, including, but not limited to, the following:
 - 1. MCM: Metal Composite Material cladding material formed by joining two thin metal skins to polyethylene or fire-retardant core and bonded under precise temperature, pressure, and tension.
 - 2. Connection hardware for attachment of MCM panel sheets to bridge structure.
 - 3. Sealants between panel components and between panels and adjoining construction; sealant around penetrations in the panels; sealants between panel flashings.
 - 4. Drilling and tapping of structure as required for fastening of all work included in this Section.
 - 5. Cutting and flashing required for penetrations.

1.02 PAYMENT

- A. No separate payment shall be made for performing any Work required under this Section. All costs for Work required by this Section shall be included in the applicable Cove Park lump sum(s) as set forth in Section 012901.

1.03 RELATED SECTIONS

- A. General Conditions Article 4.7 – Shop Drawings and Other Submittals.
- B. Section 012901 – Measurement and Payment.
- C. Section 017700 – Contract Closeout.
- D. Section 079200 - Joint Sealers.

E. Requirements from the following section also apply to this Section

1. Section 055000 Miscellaneous Metals.

1.04 PREINSTALLATION MEETINGS

A. Prior to beginning the installation of the MCM materials, attend onsite preinstallation meeting.

1. Meet with DEP, Construction Manager and the Architect/Engineer, DEP's insurer if applicable, metal composite material panel Installer, metal composite material panel manufacturer's representative, structural-support Installer, and installers whose work interfaces with or affects metal composite material panels, including installers of Electrical conduits and lighting fixtures.
2. Review and finalize construction schedule and verify availability of materials, Installer's personnel, equipment, and facilities needed to make progress and avoid delays.
3. Review methods and procedures related to metal composite material panel installation, including manufacturer's written instructions.
4. Examine support conditions for compliance with requirements, including alignment between and attachment to structural members.
5. Review flashings, special siding openings details for lighting fixtures, and condition of other construction that affect metal composite material panels.
6. Review governing regulations and requirements for insurance, certificates, and tests and inspections if applicable.
7. Review temporary protection requirements for metal composite material panel assembly during and after installation.
8. Review procedures for repair of panels damaged after installation.
9. Document proceedings, including corrective measures and actions required, and furnish copy of record to each participant.

1.05 SUBMITTALS

A. Submit the following items in accordance with General Conditions Article 4.7.

B. Product Data: For each type of product.

1. Include construction details, material descriptions, dimensions of individual components and profiles, and finishes for each type of panel and accessory.

C. Shop Drawings:

1. Include fabrication and installation layouts of metal composite material panels; details of edge conditions, joints, panel profiles, corners, anchorages, attachment assembly, trim, flashings, closures, stiffeners and accessories; and special details. Show expansion joint details and waterproof connections to adjoining work and at obstructions and penetrations. Show all penetrations required by work of all trades.
 - a. Provide distinction between factory-assembled, and field-assembled work.
 - b. Provide details of Manufacturer's standard sheet metal trims and components of panel construction, anchorage methods and hardware.
2. Accessories: Include details of the flashing, trim and anchorage, at a scale of not less than 1-1/2 inches per 12 inches.

D. Samples for Initial Selection: For each type of metal composite material panel indicated with factory-applied color finishes.

1. Include similar Samples of trim and accessories involving color selection.

E. Samples for Verification: For each type of exposed finish required, prepared on Samples of size indicated below.

1. Metal Composite Material Panels: 12 inches long by actual panel width. Include fasteners, closures, and other metal composite material panel accessories. Submit custom color samples in paint manufacturer's standard size.

F. Qualification Data: For Installer.

G. Product Test Reports: For each product, tests performed by a qualified testing agency.

1. MCM Manufacturer's Material Test Reports: Certified test reports showing compliance with specific performance or third-party listing documenting compliance to comparable code sections IBC 1407.14 and IBC 1703.5.
2. MCM System Fabricator's Certified System Tests Reports: Certified system test reports showing system compliance with specific performance or third-party listing documenting compliance code section. Base performance requirements on MCM system type provided.
 - a. Wet System: Tested to AAMA 501.
 - b. DBVR System: Tested to AAMA 509.
 - c. PER System: Tested to AAMA 508.

- C. Field quality-control reports.
- D. Sample Warranties: For special warranties.

1.06 CLOSEOUT SUBMITTALS

- A. Maintenance Data: For metal composite material panels to include in maintenance manuals.

1.07 QUALITY ASSURANCE

- A. Comply with the requirements specified in Section 014300.
- B. Installer Qualifications: Installers and supervisors who are trained and approved by manufacturer.
- C. Mockups: Before proceeding with fabrication of Metal Composite Material Panel, build mockups at location acceptable to the DEP and the Architect/Engineer to verify selections made under sample submittals and to demonstrate aesthetic effects and set quality standards for fabrication and installation.
 - 1. Build mockup of typical metal composite material panel assembly as shown on Contract Drawings with full size curved panel, including supports, attachments, stiffeners and accessories.
 - 2. Water-Spray Test: Conduct water-spray test of mockup of metal composite material panel assembly, testing for water penetration according to AAMA 501.2.
 - 3. Approval of mockups does not constitute approval of deviations from the Contract Documents contained in mockups unless Architect/Engineer specifically approves such deviations in writing.
 - 4. Subject to compliance with requirements, approved mockups may become part of the completed Work if undisturbed at time of Substantial Completion.

1.08 DELIVERY, STORAGE, AND HANDLING

- A. Comply with the requirements specified in Section 016100.
- B. Deliver components, metal composite material panels, and other manufactured items so as not to be damaged or deformed. Package metal composite material panels for protection during transportation and handling.
- C. Unload, store, and erect metal composite material panels in a manner to prevent bending, warping, twisting, and surface damage.

- D. Stack metal composite material panels horizontally on platforms or pallets, covered with suitable weathertight and ventilated covering. Store metal composite material panels to ensure dryness, with positive slope for drainage of water. Do not store metal composite material panels in contact with other materials that might cause staining, denting, or other surface damage.
- E. Retain strippable protective covering on metal composite material panels during installation.
- F. Reflective Mirror Panels: Wear gloves when handling to prevent fingerprints and soiling of surface.

1.09 FIELD CONDITIONS

- A. Weather Limitations: Proceed with installation only when existing and forecasted weather conditions permit assembly of metal composite material panels to be performed according to manufacturers' written instructions and warranty requirements.
- B. Field Measurements: Verify locations of structural members and opening dimensions by field measurements before panel fabrication and indicate measurements of Shop Drawings.

1.10 COORDINATION

- A. Coordinate metal composite material panel installation with rain drainage work, flashing, trim, construction of soffits, and other adjoining work to provide a leakproof, secure, and noncorrosive installation.

1.11 WARRANTY

- A. Warranty: Manufacturer's standard form in which manufacturer agrees to repair or replace components of metal composite material panel systems that fail in materials or workmanship within specified warranty period.
 - 1. Failures include, but are not limited to, the following:
 - a. Structural failures including rupturing, cracking, or puncturing.
 - b. Deterioration of metals and other materials beyond normal weathering.
 - 2. Warranty Period: Five (5) years from date of Substantial Completion.
- B. Special Warranty on Panel Finishes: Manufacturer's standard form in which manufacturer agrees to repair finish or replace metal composite material panels that show evidence of deterioration of factory-applied finishes within specified warranty period.

1. Exposed Panel Finish: Deterioration includes, but is not limited to, the following:
 - a. Color fading, Loss of Color Retention: Loss of 5 Delta E units (Hunter) or less when tested in accordance with ASTM D 2244.
 - b. Chalking in excess of a No. 8 rating or less when tested in accordance with ASTM D 4214.
 - c. Cracking, checking, peeling, or failure of paint to adhere to bare metal.
 - d. Salt Spray, Accelerated: At least 3,000 hours in accordance with ASTM B 117.
2. Finish Warranty Period: Ten (10) years from date of Substantial Completion.

PART 2 - PRODUCTS

2.01 PERFORMANCE REQUIREMENTS

- A. Structural Performance: Provide metal composite material panel systems capable of withstanding the effects of the following loads, based on testing according to ASTM E 330:
 1. Deflection Limits: For wind loads, no greater than 1/240 of the span, and
 2. Certified to be without permanent deformation or failure of structural members.
- B. Air Infiltration: Air leakage of not more than 0.12 cfm/sq. ft. of wall area, when tested according to ASTM E 283 at the following test-pressure difference:
 1. Test-Pressure Difference: 6.24 lbf/sq. ft. (300 Pa).
- C. Water Penetration under Static Pressure: No water penetration when tested according to ASTM E 331 at the following test-pressure difference:
 1. Test-Pressure Difference: 6.24 lbf/sq. ft. (300 Pa).
- D. Thermal Movements: Allow for thermal movements from ambient and surface temperature changes by preventing buckling, opening of joints, overstressing of components, failure of joint sealants, failure of connections, and other detrimental effects. Base calculations on surface temperatures of materials due to both solar heat gain and nighttime-sky heat loss.
 1. Temperature Change (Range): Minus 20 deg F to 180 deg F (minus 29 to 82.2 deg C), material surfaces.

- E. Fire-Resistance Ratings: Comply with ASTM E 119; testing by a qualified testing agency. Identify products with appropriate markings of applicable testing agency.
 - 1. Indicate design designations from UL's "Fire Resistance Directory" or from the listings of another qualified testing agency.
- F. Fire Propagation Characteristics: Metal composite material wall panel system passes NFPA 285 testing.

2.02 METAL COMPOSITE MATERIAL PANELS

- A. Metal Composite Material Wall Panel Systems: Provide factory-formed and -assembled, metal composite material wall panels fabricated from two metal facings that are bonded to a solid, extruded thermoplastic core; formed into profile for installation method indicated. Include attachment assembly components, panel stiffeners, and accessories required for weathertight system.
 - 1. Basis-of-Design Product: Subject to compliance with requirements, provide ALUCOBOND®; 3A Composites USA Inc.; ALUCOBOND® PLUS or comparable product by one of the following:
 - a. Arconic Architectural Products (USA).
 - b. Alucoil North America.
 - c. Citadel Architectural Products Inc.
 - d. Or approved equal.
- B. Aluminum-Faced Composite Wall Panels: Formed with 0.020-inch- (0.50-mm-) thick, aluminum sheet facings.
 - 1. Panel Thickness: 0.236 inch (6 mm).
 - 2. Core: Fire retardant.
 - 3. Exterior Finish: FEVE fluoropolymer, Clear anodized, Polished Reflect Mirror finish.
 - a. Color: As selected by Architect - Reflect Mirror.
 - 4. Peel Strength: 22.5 in-lb/in. when tested for bond integrity in accordance with ASTM D1781.

5. Fire Performance: Flame spread less than 25 and smoke developed less than 450, in accordance with ASTM E84.

C. Attachment Assembly Components: Formed from extruded aluminum, material compatible with panel facing.

2.03 MISCELLANEOUS MATERIALS

A. Miscellaneous Metal Subframing and Furring: ASTM C 645, cold-formed, metallic-coated steel sheet ASTM A 653/A 653M, G90 (Z275 hot-dip galvanized) coating designation or ASTM A 792/A 792M, Class AZ50 (Class AZM150) aluminum-zinc-alloy coating designation unless otherwise indicated. Provide manufacturer's standard sections as required for support and alignment of metal composite material panel system.

B. Flashing and Trim: Provide flashing and trim formed from same material as metal composite material panels as required to seal against weather and to provide finished appearance. Locations include, but are not limited to, bases, drips, sills, jambs, corners, endwalls, framed openings, rakes, fasciae, parapet caps, soffits, reveals, and fillers. Finish flashing and trim with same finish system as adjacent metal composite material panels.

C. Panel Fasteners: Self-tapping screws designed to withstand design loads. Provide exposed fasteners with heads matching color of metal composite material panels by means of plastic caps or factory-applied coating. Provide EPDM or PVC sealing washers for exposed fasteners.

D. Panel Sealants: ASTM C 920; elastomeric polyurethane or silicone sealant; of type, grade, class, and use classifications required to seal joints in metal composite material panels and remain weathertight; and as recommended in writing by metal composite material panel manufacturer.

2.04 MANUFACTURING TOLERANCES

A. Manufacture panel system so as not to exceed manufacturing tolerances.

B. Maximum deviation of any point from its theoretical mathematical position: Flatness tolerances shall not exceed one half or 50 percent of the allowable even tolerances for the manufacturer of the Metal Composite Material.

C. Measurements are on flat, curved, multiple curved surfaces exposed to view.

D. Burden of proof that tolerances comply with these specifications lies with MCM panel system manufacturer.

2.05 FABRICATION

- A. General: Fabricate and finish metal composite material panels and accessories at the factory, by manufacturer's standard procedures and processes, as necessary to fulfill indicated performance requirements demonstrated by laboratory testing. Comply with indicated profiles and with dimensional and structural requirements.
- B. Fabricate metal composite material panel joints with factory-installed captive gaskets or separator strips that provide a weathertight seal and prevent metal-to-metal contact, and that minimize noise from movements.
- C. Sheet Metal Flashing and Trim: Fabricate flashing and trim to comply with manufacturer's recommendations and recommendations in SMACNA's "Architectural Sheet Metal Manual" that apply to design, dimensions, metal, and other characteristics of item indicated.
 - 1. Form exposed sheet metal accessories that are without excessive oil canning, buckling, and tool marks and that are true to line and levels indicated, with exposed edges folded back to form hems.
 - 2. Seams for Aluminum: Fabricate nonmoving seams with flat-lock seams. Form seams and seal with epoxy seam sealer. Rivet joints for additional strength.
 - 3. Seams for Other Than Aluminum: Fabricate nonmoving seams in accessories with flat-lock seams. Tin edges to be seamed, form seams, and solder.
 - 4. Sealed Joints: Form non-expansion, but movable, joints in metal to accommodate sealant and to comply with SMACNA standards.
 - 5. Conceal fasteners and expansion provisions where possible. Exposed fasteners are not allowed on faces of accessories exposed to view.
 - 6. Fabricate cleats and attachment devices from same material as accessory being anchored or from compatible, noncorrosive metal recommended in writing by metal panel manufacturer.
 - a. Size: As recommended by SMACNA's "Architectural Sheet Metal Manual" or metal wall panel manufacturer for application but not less than thickness of metal being secured.

2.06 FINISHES

- A. Protect mechanical and painted finishes on exposed surfaces from damage by applying a strippable, temporary protective covering before shipping.

- B. Appearance of Finished Work: Variations in appearance of abutting or adjacent pieces are acceptable if they are within one-half of the range of approved Samples. Noticeable variations in same piece are not acceptable. Variations in appearance of other components are acceptable if they are within the range of approved Samples and are assembled or installed to minimize contrast.
- C. Aluminum Panels and Accessories:
1. Two-Coat Fluoropolymer: AAMA 2605. Fluoropolymer finish containing not less than 70 percent PVDF resin by weight in color coat. Prepare, pretreat, and apply coating to exposed metal surfaces to comply with coating and resin manufacturers' written instructions.
 2. Three-Coat Fluoropolymer: AAMA 620. Fluoropolymer finish containing not less than 70 percent PVDF resin by weight in both color coat and clear topcoat. Prepare, pretreat, and apply coating to exposed metal surfaces to comply with coating and resin manufacturers' written instructions.
 3. Mica Fluoropolymer: AAMA 2605. Two-coat fluoropolymer finish with suspended mica flakes containing not less than 70 percent PVDF resin by weight in color coat. Prepare, pretreat, and apply coating to exposed metal surfaces to comply with coating and resin manufacturers' written instructions.
 4. Metallic Fluoropolymer: AAMA 2605. Three-coat fluoropolymer finish with suspended metallic flakes containing not less than 70 percent PVDF resin by weight in both color coat and clear topcoat. Prepare, pretreat, and apply coating to exposed metal surfaces to comply with coating and resin manufacturers' written instructions.
 5. FEVE Fluoropolymer: AAMA 2605. Two-coat fluoropolymer finish containing 100 percent fluorinated ethylene vinyl ether resin in color coat. Prepare, pretreat, and apply coating to exposed metal surfaces to comply with coating and resin manufacturers' written instructions.
 6. Exposed Anodized Finish:
 - a. Clear Anodic Finish: AAMA 611, AA-M12C22A41, Class I, 0.018 mm or thicker.
 - b. Color Anodic Finish: AAMA 611, AA-M12C22A42/A44, Class I, 0.018 mm or thicker.

PART 3 - EXECUTION

3.01 EXAMINATION

- A. Examine substrates, areas, and conditions, with Installer present, for compliance with requirements for installation tolerances, metal composite material panel supports, and other conditions affecting performance of the Work.
 - 1. Examine wall framing to verify that girts, angles, channels, studs, and other structural panel support members and anchorage have been installed within alignment tolerances required by metal composite material wall panel manufacturer.
 - 2. Examine wall sheathing to verify that sheathing joints are supported by framing or blocking and that installation is within flatness tolerances required by metal composite material wall panel manufacturer.
- B. Examine roughing-in for components and assemblies penetrating metal composite material panels to verify actual locations of penetrations relative to seam locations of metal composite material panels before installation.
- C. Proceed with installation only after unsatisfactory conditions have been corrected.

3.02 PREPARATION

- A. Miscellaneous Supports: Install subframing, furring, and other miscellaneous panel support members and anchorages according to ASTM C 754 and metal composite material panel manufacturer's written recommendations.

3.03 METAL COMPOSITE MATERIAL PANEL INSTALLATION

- A. General: Install metal composite material panels according to manufacturer's written instructions in orientation, sizes, and locations indicated on Drawings. Install panels perpendicular to supports unless otherwise indicated. Anchor metal composite material panels and other components of the Work securely in place, with provisions for thermal and structural movement.
 - 1. Shim or otherwise plumb substrates receiving metal composite material panels.
 - 2. Flash and seal metal composite material panels at perimeter of all openings. Fasten with self-tapping screws. Do not begin installation until air- or water-resistive barriers and flashings that will be concealed by metal composite material panels are installed.
 - 3. Install screw fasteners in predrilled holes.

4. Locate and space fastenings in uniform vertical and horizontal alignment.
 5. Install flashing and trim as metal composite material panel work proceeds.
 6. Locate panel splices over, but not attached to, structural supports. Stagger panel splices and end laps to avoid a four-panel lap splice condition.
 7. Align bottoms of metal composite material panels and fasten with blind rivets, bolts, or self-tapping screws. Fasten flashings and trim around openings and similar elements with self-tapping screws.
 8. Provide weathertight escutcheons for pipe- and conduit-penetrating panels.
- B. Fasteners:
1. Aluminum Panels: Use aluminum or stainless-steel fasteners for surfaces exposed to the exterior; use aluminum or galvanized-steel fasteners for surfaces exposed to the interior.
- C. Metal Protection: Where dissimilar metals contact each other or corrosive substrates, protect against galvanic action as recommended in writing by metal composite material panel manufacturer.
- D. Attachment Assembly, General: Install attachment assembly required to support metal composite material wall panels and to provide a complete weathertight wall system, including subgirts, perimeter extrusions, tracks, drainage channels, panel clips, and anchor channels.
1. Include attachment to supports, panel-to-panel joinery, panel-to-dissimilar-material joinery, and panel-system joint seals.
- E. Installation: Attach metal composite material wall panels to supports at locations, spacings, and with fasteners recommended by manufacturer to achieve performance requirements specified.
1. Wet Seal Systems: Seal horizontal and vertical joints between adjacent metal composite material wall panels with sealant backing and sealant. Install sealant backing and sealant according to requirements specified in Section 079200 "Joint Sealants."
 2. Dry Seal Systems: Seal horizontal and vertical joints between adjacent metal composite material wall panels with manufacturer's standard gasket system.
 3. Rainscreen Systems: Do not apply sealants to joints unless otherwise indicated.

- F. **Clip Installation:** Attach panel clips to supports at locations, spacings, and with fasteners recommended by manufacturer. Attach routed-and-turned flanges of wall panels to panel clips with manufacturer's standard fasteners.
1. Seal horizontal and vertical joints between adjacent panels with sealant backing and sealant. Install sealant backing and sealant according to requirements specified in Section 079200.
 2. Seal horizontal and vertical joints between adjacent metal composite material wall panels with manufacturer's standard gaskets.
- G. **Subgirt-and-Spline Installation:** Install support assembly at locations, spacings, and with fasteners recommended by manufacturer. Use manufacturer's standard subgirts and splines that provide support and complete secondary drainage assembly, draining to the exterior at horizontal joints. Attach metal composite material wall panels by interlocking perimeter extrusions attached to panels with subgirts and splines. Fully engage integral subgirt-and-spline gaskets and leave horizontal and vertical joints with open reveal. Terminate edge of panels flush with perimeter extrusions.
1. Install wall panels to allow individual panels to "free float" and be installed and removed without disturbing adjacent panels.
 2. Do not apply sealants to joints unless otherwise indicated.
- H. **Track-Support Installation:** Install support assembly at locations, spacings, and with fasteners recommended by manufacturer. Use manufacturer's standard horizontal tracks and vertical tracks that provide support and secondary drainage assembly, draining to the exterior at horizontal joints through drain tube. Attach metal composite material wall panels to tracks by interlocking panel edges with manufacturer's standard "T" clips.
1. Attach routed-and-turned flanges of wall panels to perimeter extrusions with manufacturer's standard fasteners.
 2. Attach flush wall panels to perimeter extrusions by engaging panel edges and by attaching with manufacturer's standard structural silicone adhesive.
 3. Install wall panels to allow individual panels to "free float" and be installed and removed without disturbing adjacent panels.
 4. Do not apply sealants to joints unless otherwise indicated.
- I. **Rainscreen-Principle Installation:** Install using manufacturer's standard assembly with vertical channel that provides support and secondary drainage assembly, draining at base of wall. Notch vertical channel to receive support pins. Install vertical channels supported by channel brackets or adjuster angles and at locations, spacings, and with fasteners recommended by manufacturer. Attach metal composite material wall panels by inserting

horizontal support pins into notches in vertical channels and into flanges of panels. Leave horizontal and vertical joints with open reveal.

1. Install wall panels to allow individual panels to be installed and removed without disturbing adjacent panels.
 2. Do not apply sealants to joints unless otherwise indicated.
- J. Accessory Installation: Install accessories with positive anchorage to building and weathertight mounting, and provide for thermal expansion. Coordinate installation with flashings and other components.
1. Install components required for a complete metal composite material panel assembly including trim, copings, corners, seam covers, flashings, sealants, gaskets, fillers, closure strips, and similar items. Provide types indicated by metal composite material panel manufacturer; or, if not indicated, provide types recommended in writing by metal composite material panel manufacturer.
- K. Flashing and Trim: Comply with performance requirements, manufacturer's written installation instructions, and SMACNA's "Architectural Sheet Metal Manual." Provide concealed fasteners where possible, and set units true to line and level as indicated. Install work with laps, joints, and seams that are permanently watertight.
1. Install exposed flashing and trim that is without buckling and tool marks and that is true to line and levels indicated, with exposed edges folded back to form hems. Install sheet metal flashing and trim to fit substrates and to result in waterproof performance.
 2. Expansion Provisions: Provide for thermal expansion of exposed flashing and trim. Space movement joints at a maximum of 10 feet (3 m) with no joints allowed within 24 inches (605 mm) of corner or intersection. Where lapped expansion provisions cannot be used or would not be sufficiently waterproof, form expansion joints of intermeshing hooked flanges, not less than 1 inch (25 mm) deep, filled with mastic sealant (concealed within joints).

3.04 ERECTION TOLERANCES

- A. Installation Tolerances: Shim and align metal composite material wall panel units within installed tolerance of 1/4 inch in 20 feet (6 mm in 6 m), non-accumulative, on level, plumb, and location lines as indicated, and within 1/8-inch (3-mm) offset of adjoining faces and of alignment of matching profiles.

3.05 FIELD QUALITY CONTROL

- A. Testing Agency: DEP will engage a qualified independent testing agency to perform field tests and inspections.

- B. Water-Spray Test: After installation, test area of assembly shown on Drawings 50 square feet for water penetration according to AAMA 501.2.
- C. Manufacturer's Field Service: Engage a factory-authorized service representative to test and inspect completed metal composite material wall panel installation, including accessories.
- D. Metal composite material panels will be considered defective if they do not pass test and inspections.
- E. Additional tests and inspections, at Contractor's expense, are performed to determine compliance of replaced or additional work with specified requirements.
- F. Prepare test and inspection reports.

3.06 CLEANING AND PROTECTION

- A. Remove temporary protective coverings and strippable films, if any, as metal composite material panels are installed, unless otherwise indicated in manufacturer's written installation instructions. On completion of metal composite material panel installation, clean finished surfaces as recommended by metal composite material panel manufacturer. Maintain in a clean condition during construction.
- B. After metal composite material panel installation, clear weep holes and drainage channels of obstructions, dirt, and sealant.
- C. Replace metal composite material panels that have been damaged or have deteriorated beyond successful repair by finish touchup or similar minor repair procedures.

3.07 CLOSEOUT ACTIVITIES

- A. Provide in accordance with Section 017700.

END OF SECTION 074213

NO TEXT ON THIS PAGE

SECTION 079000 – EXPANSION CONTROL - SEISMIC JOINT SYSTEM

PART 1 – GENERAL

1.01 SUMMARY

- A. The work shall consist of furnishing and installing waterproof expansion joints in accordance with the requirements of the Contract Documents. Expansion joint shall be comprised of a sealing assembly made up of two horizontal joints made of silicone-coated, precompressed foam pre-assembled in parallel adjacent to a heavy-duty extruded aluminum spline. The spline shall act as a receptor for attaching a surface-mounted traffic plate.

1.02 PAYMENT

- A. No separate payment shall be made for performing any Work required under this Section. All costs for Work required by this Section shall be included in the applicable Cove Park lump sum(s) as set forth in Section 012901.

1.03 RELATED WORK

- A. General Conditions Article 4.7 – Shop Drawings and Other Submittals
- B. Section 012901 – Measurement and Payment
- C. Section 014300 - Quality Requirements
- D. Section 016100 – Control of Materials
- E. Section 017700 – Closeout Contract
- F. Requirements from the following sections also apply to this Section:
 - 1. Section 03300 - Cast-in-Place Concrete
 - 2. Division 7 - Thermal & Moisture Protection
 - 3. Division 7 - Sealants, Caulking and Waterproofing

1.04 SUBMITTALS

- A. General – Submit the following according to General Conditions Article 4.7.
- B. Standard Submittal Package – Submit typical expansion joint drawing(s) indicating pertinent dimensions, general construction, expansion joint opening dimensions and product information.

- C. Alloys where used:
 - 1. Plates: Aluminum 6061-T6 alloy meeting ASTM B221-95a
 - 2. Plates: Stainless Steel Grade 304 meeting ASTM A240 and A666
- D. Sample of material is required at time of submittal.
- E. All products must be certified by independent laboratory test report to be free in composition of any waxes or wax compounds using FTIR and DSC testing.
- F. All products shall be certified in writing to be: a) capable of withstanding 150 degrees F (65 degrees C) for 3 hours while compressed down to the minimum of movement capability dimension of the basis of design product (-50 percent of nominal material size) without evidence of any bleeding of impregnation medium from the material; and b) that the same material after the heat stability test and after first being cooled to room temperature will subsequently self-expand to the maximum of movement capability dimension of the basis-of-design product (+50 percent of nominal material size) within 24 hours at room temperature 68 degrees F (20 degrees C).
- G. A FEA Report by a certified engineer must be submitted providing engineering information stating lateral and non-linear displacement and safety factors on key system components under conditions simulating a 4000 lb vehicle skidding across the joint system inducing an 800 lb tangential load. Product must demonstrate FEA Safety Factors: Traffic Plate – 5; Screws – 11; Spline Pins - 10; Center Spline – 7.
- H. All products must be certified by independent laboratory test report to be tested to meet or exceed ASTM C1028 the standard method for determining Static Coefficient of Friction (SCOF).
- I. All foam/spline/hangar-bar components shall be pre-assembled at the factory. No field assembly of component foam-to centering spline shall be allowed. No field assembly of metal-to-metal or plastic or rubber spline components shall be permitted.
- J. Finished systems shall have factory pre-cured, elastomeric silicone bellows disposed on the upward facing surface of the flanking foam as the primary source of water proofing.
- K. Sealers, sealants, or saturates infused into the upper areas of the foam matrixes for the intended purpose of performing or contributing to performance as an elastomeric waterproofing layer in lieu of a silicone bellows layer shall NOT be permitted.
- L. A silicone sealant band must be installed between the substrates and outer pre-cured silicone bellows throughout the length of the assembly as well as at the interface of factory preassembled units.

- M. Quality and Environmental Control: Manufacturer shall be certified to both ISO-9001:2015 (quality management) and ISO-14001:2015 (environmental management) and shall provide written confirmation that formal Quality and Environmental management systems and processes have been adopted.

1.05 PRODUCT DELIVERY, STORAGE AND HANDLING

- A. Comply with the requirements in Section 016100.
- B. Deliver products to site in Manufacturer's original, intact, labeled containers. Handle and protect as necessary to prevent damage or deterioration during shipment, handling and storage. Store in accordance with manufacturer's installation instructions.
- C. Basis-of-Design
 - 1. All joints shall be designed to meet the specified performance criteria of the project as manufactured by: (USA & International) EMSEAL JOINT SYSTEMS, LTD 25 Bridle Lane, Westborough, MA 01581-2603, Toll Free: 800-526-8365. (Canada) EMSEAL, LLC 120 Carrier Drive, Toronto, Ontario, Canada M9W 5R1 Toll Free: 800-526-8365. www.emseal.com Balco ACSW Industrials Co., Nystrom, Inc., or approved equal
 - 2. Alternate manufacturers must demonstrate that their products meet or exceed the design criteria and must submit certified performance test reports performed by nationally recognized independent laboratories as called for in section 1.02 Submittals. Submittal of alternates must be made three weeks prior to bid opening to allow proper evaluation time.

1.06 QUALITY ASSURANCE

- A. Comply with the requirements specified in Section 014300.
- B. The Contractor will conduct a pre-construction meeting with all parties and trades involved in the treatment of work at and around expansion joints including, but not limited to, concrete, mechanical, electrical, HVAC, landscaping, masonry, curtain wall, waterproofing, fire-stopping, caulking, flooring and other finish trade subcontractors. All superintendents and foremen with responsibility for oversight and setting of the joint gap must attend this meeting. The Contractor is responsible to coordinate and schedule all trades and ensure that all subcontractors understand their responsibilities in relation to expansion joints and that their work cannot impede anticipated structural movement at the expansion joints, or compromise the achievement of watertightness or life safety at expansion joints in any way.
- C. Warranty – Manufacturer's standard warranty shall apply.

- D. LEED Building Performance Requirements: The VOC of the silicone must not exceed 50 grams/liter.

PART 2 – PRODUCT

2.01 GENERAL

- A. Provide traffic durable, watertight, sound dampened, seismic, large-gap, and high-movement expansion joint. Typical locations include but are not limited to the following: applications over occupied space, stadiums, floors, and parking decks. System shall perform waterproofing, traffic bearing and movement-accommodation functions as the result of a single installation and without the addition of gutters, vapor barriers, bladders, or other devices suspended beneath or within the system in any way.
- B. Provide SJS as indicated on drawings for horizontal expansion joint locations.
- C. Sealant system shall be comprised of the following components:
 - 1. Cellular foam infused with a hydrophobic, modified-acrylic dispersion
 - 2. Pre-coated with a watertight silicone outer coating
 - 3. Heavy-duty extruded aluminum center spline
 - 4. Interlocking spline connectors and heavy-duty cover plates
 - 5. Field-applied epoxy adhesive primer
 - 6. Field-injected silicone sealant bands.
- D. Material shall be capable of movements of +50 percent, -50 percent (100 percent total) of nominal material size. Standard sizes from 4 inches (100 mm) and greater. Depth of seal as recommended by manufacturer.
- E. Silicone coating to be highway-grade, low-modulus, jet-fuel resistant silicone applied to the impregnated foam sealant at a width greater than maximum allowable joint extension and which when cured and compressed will form a bellows.
- F. SJS to be installed directly over a leveling-bed of elastomeric nosing material to be supplied by manufacturer. Elastomeric nosing material to have an aggregate of fine, washed sand not to exceed 30 mesh and chopped strand fiberglass and aggregate to resin ratio not to exceed 2:1 by weight.
- G. SJS to be installed into manufacturer's standard field-applied epoxy adhesive.

- H. The foam seal is to be installed slightly recessed from the surface such that when the field-applied injection band of silicone is installed between the substrates and the foam-and-silicone-bellows, the system will be essentially flush with the substrate surface.
- I. Tool-steel, connector pins shall be located in center spline for end-to-end connections. Heavy duty cover plate to be held in place by stainless-steel, self-tapping screws installed into the continuous anchor channel of the heavy-duty extruded spline. No invasive anchors, mechanical self-centering bars, springs, or sliding ball components shall be employed in maintaining coverplate attachment and centering.
- J. Select the sealant system model appropriate to the movement and design requirements at each joint location that meet the project specification or as defined by the structural Engineer of Record.
- K. Manufacturer's Checklist must be completed by expansion joint subcontractor and returned to manufacturer at time of ordering material.

2.02 FABRICATION

- A. SJS by EMSEAL must be supplied pre-assembled and precompressed to less than the joint size, packaged in shrink-wrapped lengths (sticks).
- B. Directional changes and terminations into vertical plane surfaces (walls, parapets, ends of decks, etc.) as well as to transition the material through curbs, treads and risers or other in-slab plane changes to be provided by factory-manufactured single units or through field fabrication in strict accordance with published installation instructions.

PART 3 – EXECUTION

3.01 INSPECTION AND STORAGE OF MATERIALS

- A. Customer is responsible for inspection and proper storage of material upon arrival. Coverplate metals, when in contact with moisture while in their packaging, may discolor-ensure shipments are kept dry.
- B. Preparation of the Work Area
 1. The Contractor shall provide properly formed and prepared expansion joint openings constructed to the exact dimensions and elevations shown on manufacturer's standard system drawings or as shown on the contract drawings. Deviations from these dimensions will not be allowed without the written consent of the Engineer of Record.
 2. The Contractor shall clean the joint opening of all contaminants immediately prior to installation of expansion joint system. Repair spalled, irregular or unsound joint

surfaces using accepted industry practices for repair of the substrates in question. Remove protruding roughness to ensure joint sides are smooth. Ensure that there is sufficient depth to receive the full depth of the size of the SJS being installed. Refer to Manufacturers Installation Guide for detailed step-by-step instructions.

3. No drilling, or screwing, or fasteners of any type are permitted to anchor the system into the substrate.
4. System to be installed by qualified sub-contractors only according to detailed published installation procedures and/or in accordance with job-specific installation instructions of manufacturer's field technician. Bids must include for presence of paid-for manufacturer's field technician to be present during initial preparation, inspection, and material installation.

3.02 CLEAN AND PROTECT

- A. Protect the system and its components during construction. Subsequent damage to the expansion joint system will be repaired at the Contractor's expense. After work is complete, clean exposed surfaces with a suitable cleaner that will not harm or attack the finish.

3.03 CLOSEOUT CONTRACT

- A. Provide in accordance with Section 017700.

END OF SECTION 079000

SECTION 079200 - JOINT SEALANTS

PART 1 - GENERAL

1.01 DESCRIPTION

A. Provide joint sealants as indicated and in compliance with Contract Documents.

1. Section Includes:

a. Nonstaining silicone joint sealants

1.02 PAYMENT

A. No separate payment shall be made for performing any Work required under this Section. All costs for Work required by this Section shall be included in the applicable Cove Park lump sum(s) as set forth in Section 012901.

1.03 REFERENCES

A. ASTM International (ASTM):

1. C834: Standard Specification for Latex Sealing Compounds.
2. C919: Standard Practice for Use of Sealants in Acoustical Applications.
3. C920: Standard Specification for Elastomeric Joint Sealants.
4. C1021: Standard Practice for Laboratories Engaged in Testing of Building Sealants.
5. C1087: Standard Test Method for Determining Compatibility of Liquid-Applied Sealants with Accessories Used in Structural Glazing Systems.
6. C1193: Standard Guide for Use of Joint Sealants.
7. C1247: Standard Test Method for Durability of Sealants Exposed to Continuous Immersion in Liquids.
8. C1248: Standard Test Method for Staining of Porous Substrate by Joint Sealants.
9. C1311: Standard Specification for Solvent Release Sealants.
10. C1330: Standard Specification for Cylindrical Sealant Backing for Use with Cold Liquid-Applied Sealants.

11. C1521: Standard Practice for Evaluating Adhesion of Installed Weatherproofing Sealant Joints.
12. E90: Standard Test Method for Laboratory Measurement of Airborne Sound Transmission Loss of Building Partitions and Elements.

1.04 RELATED SECTIONS

- A. General Conditions Article 4.7 – Shop Drawings and Other Submittals
- B. Section 012901 - Measurement and Payment
- C. Section 014300 – Quality Requirements
- D. Section 017700 – Contract Closeout

1.05 SUBMITTALS

- A. Submit the following shop drawings in accordance with General Conditions Article 4.7.
- B. Product Data: For each joint-sealant product indicated.
- C. Samples for Initial Selection: Manufacturer's color charts consisting of strips of cured sealants showing the full range of colors available for each product exposed to view.
- D. Samples for Verification: For each kind and color of joint sealant required, provide Samples with joint sealants in 1/2-inchwide joints formed between two 6-inch- long strips of material matching the appearance of exposed surfaces adjacent to joint sealants.
- E. Joint-Sealant Schedule: Include the following information:
 1. Joint-sealant application, joint location, and designation.
 2. Joint-sealant manufacturer and product name.
 3. Joint-sealant formulation.
 4. Joint-sealant color.
 5. Qualification Data: For qualified testing agency.
 6. Product Test Reports: For each kind of joint sealant, for tests performed by a qualified testing agency.
 7. Preconstruction Laboratory Test Schedule: Include the following information for each joint sealant and substrate material to be tested:
 - a. Joint-sealant location and designation.

- b. Manufacturer and product name.
 - c. Type of substrate material.
 - d. Proposed test.
 - e. Number of samples required.
8. Preconstruction Laboratory Test Reports: From sealant manufacturer, indicating the following:
- a. Materials forming joint substrates and joint-sealant backings have been tested for compatibility and adhesion with joint sealants.
 - b. Interpretation of test results and written recommendations for primers and substrate preparation are needed for adhesion.
9. Preconstruction Field-Adhesion-Test Reports: Indicate which sealants and joint preparation methods resulted in optimum adhesion to joint substrates based on testing specified in "Preconstruction Testing" Article.
10. Field-Adhesion-Test Reports: For each sealant application tested.
11. Sample Warranties: For special warranties.

1.06 QUALITY ASSURANCE

- A. Comply with the requirements specified in Section 014300.
- B. Installer Qualifications: Manufacturer's authorized representative who is trained and approved for installation of units required for this Project.
- C. Source Limitations: Obtain each kind of joint sealant from single source from single manufacturer.
- D. Product Testing: Test joint sealants using a qualified testing agency.
 1. The DEP may elect to provide third party testing. Contractor to cooperate and provide safe access to the testing agency.
- E. Mockups: Install sealant in mockups of assemblies specified in other Sections that are indicated to receive joint sealants specified in this Section. Use materials and installation methods specified in this Section.
- F. Preinstallation Conference: Conduct conference at Project site office.

1.07 PRECONSTRUCTION TESTING

- A. Preconstruction Laboratory Testing: Submit to joint-sealant manufacturers, for testing indicated below, samples of materials that will contact or affect joint sealants.
1. Adhesion Testing: Use ASTM C 794 to determine whether priming and other specific joint preparation techniques are required to obtain rapid, optimum adhesion of joint sealants to joint substrates.
 2. Compatibility Testing: Use ASTM C 1087 to determine sealant compatibility when in contact with glazing and gasket materials.
 3. Stain Testing: Use ASTM C 1248 to determine stain potential of sealant when in contact with concrete, stainless steel and aluminum substrates.
 4. Submit manufacturer's recommended number of pieces of each type of material, including joint substrates, joint-sealant backings, and miscellaneous materials.
 5. Schedule sufficient time for testing and analyzing results to prevent delaying the Work.
 6. For materials failing tests, obtain joint-sealant manufacturer's written instructions for corrective measures, including use of specially formulated primers.
 7. Testing will not be required if joint-sealant manufacturers submit data that are based on previous testing, not older than 24 months, of sealant products for adhesion to, staining of, and compatibility with joint substrates and other materials matching those submitted.
- B. Preconstruction Field-Adhesion Testing: Before installing sealants, field test their adhesion to Project joint substrates as follows:
1. Locate test joints where indicated on Project or, if not indicated, as directed by Construction Manager.
 2. Conduct field tests for each kind of sealant and joint substrate.
 3. Notify Construction Manager seven days in advance of dates and times when test joints will be erected.
 4. Arrange for tests to take place with joint-sealant manufacturer's technical representative present.
 - a. Test Method: Test joint sealants according to Method A, Field-Applied Sealant Joint Hand Pull Tab, in Appendix X1.1 in ASTM C 1193 or Method A, Tail Procedure, in ASTM C 1521.

- (1) For joints with dissimilar substrates, verify adhesion to each substrate separately; extend cut along one side, verifying adhesion to opposite side. Repeat procedure for opposite side.
5. Report whether sealant failed to adhere to joint substrates or tore cohesively. Include data on pull distance used to test each kind of product and joint substrate. For sealants that fail adhesively, retest until satisfactory adhesion is obtained.
6. Evaluation of Preconstruction Field-Adhesion-Test Results: Sealants not evidencing adhesive failure from testing, in absence of other indications of noncompliance with requirements, will be considered satisfactory. Do not use sealants that fail to adhere to joint substrates during testing.

1.08 PROJECT CONDITIONS

- A. Do not proceed with installation of joint sealants under the following conditions:
 1. When ambient and substrate temperature conditions are outside limits permitted by joint-sealant manufacturer or below 40 deg. F.
 2. When joint substrates are wet.
 3. Where joint widths are less than those allowed by joint-sealant manufacturer for applications indicated.
 4. Where contaminants capable of interfering with adhesion have not yet been removed from joint substrates.

1.09 WARRANTY

- A. Manufacturer's standard form in which Installer agrees to repair or replace joint sealants that do not comply with performance and other requirements specified in this Section within specified warranty period.
 1. Warranty Period: Two years from date of Substantial Completion.

PART 2 - PRODUCTS

2.01 MATERIALS, GENERAL

- A. Compatibility: Provide joint sealants, backings, and other related materials that are compatible with one another and with joint substrates under conditions of service and application, as demonstrated by joint-sealant manufacturer, based on testing and field experience.
- B. Colors of Exposed Joint Sealants: As selected by Architect/Engineer from manufacturer's full range.

2.02 NONSTAINING SILICONE JOINT SEALANTS

- A. Nonstaining Silicone, S, NS, 100/50, NT: Single-component, nonsag, plus 100 percent and minus 50 percent movement capability, nontraffic-use, neutral-curing silicone joint sealant; ASTM C 920, Type S, Grade NS, Class 100/50, Use NT.
 - 1. Dow Corning Corporation – Dow 995.
 - 2. GE Advanced Materials - Silicones; GE SCS9000.
 - 3. Pecora Corporation; Pecora 895.
 - 4. Tremco Incorporated; Tremco Proglaze SG.
 - 5. Or approved equal.

2.03 JOINT SEALANT BACKING

- A. General: Provide sealant backings of material that are nonstaining; are compatible with joint substrates, sealants, primers, and other joint fillers; and are approved for applications indicated by sealant manufacturer based on field experience and laboratory testing.
- B. Cylindrical Sealant Backings: ASTM C1330, Type C (closed-cell material with a surface skin) or any of the preceding types, as approved in writing by joint-sealant manufacturer for joint application indicated and of size and density to control sealant depth and otherwise contribute to producing optimum sealant performance.
- C. Bond-Breaker Tape: Polyethylene tape or other plastic tape recommended by sealant manufacturer for preventing sealant from adhering to rigid, inflexible joint-filler materials or joint surfaces at back of joint. Provide self-adhesive tape where applicable.

2.04 MISCELLANEOUS MATERIALS

- A. Primer: Material recommended by joint-sealant manufacturer where required for adhesion of sealant to joint substrates indicated, as determined from preconstruction joint-sealant-substrate tests and field tests.
- B. Cleaners for Nonporous Surfaces: Chemical cleaners acceptable to manufacturers of sealants and sealant backing materials, free of oily residues or other substances capable of staining or harming joint substrates and adjacent nonporous surfaces in any way, and formulated to promote optimum adhesion of sealants to joint substrates.
- C. Masking Tape: Nonstaining, nonabsorbent material compatible with joint sealants and surfaces adjacent to joints.

PART 3 - EXECUTION

3.01 EXAMINATION

- A. Examine joints indicated to receive joint sealants, with Installer present, for compliance with requirements for joint configuration, installation tolerances, and other conditions affecting joint-sealant performance.
- B. Proceed with installation only after unsatisfactory conditions have been corrected.

3.02 PREPARATION

- A. Surface Cleaning of Joints: Clean out joints immediately before installing joint sealants to comply with joint-sealant manufacturer's written instructions and the following requirements:
 - 1. Remove all foreign material from joint substrates that could interfere with adhesion of joint sealant, including dust, paints (except for permanent, protective coatings tested and approved for sealant adhesion and compatibility by sealant manufacturer), old joint sealants, oil, grease, waterproofing, water repellents, water, surface dirt, and frost.
 - 2. Clean porous joint substrate surfaces by brushing, grinding, mechanical abrading, or a combination of these methods to produce a clean, sound substrate capable of developing optimum bond with joint sealants. Remove loose particles remaining after cleaning operations above by vacuuming or blowing out joints with oil-free compressed air. Porous joint substrates include the following:
 - a. Concrete.
 - b. Masonry.
 - 3. Remove laitance and form-release agents from concrete.
 - 4. Clean nonporous joint substrate surfaces with chemical cleaners or other means that do not stain, harm substrates, or leave residues capable of interfering with adhesion of joint sealants. Nonporous joint substrates include the following:
 - a. Metal surface – Painted Steel, Stainless Steel and Aluminum.
- B. Joint Priming: Prime joint substrates where recommended by joint-sealant manufacturer or as indicated by preconstruction joint-sealant-substrate tests or prior experience. Apply primer to comply with joint-sealant manufacturer's written instructions. Confine primers to areas of joint-sealant bond; do not allow spillage or migration onto adjoining surfaces.
- C. Masking Tape: Use masking tape where required to prevent contact of sealant or primer with adjoining surfaces that otherwise would be permanently stained or damaged by such

contact or by cleaning methods required to remove sealant smears. Remove tape immediately after tooling without disturbing joint seal.

3.03 INSTALLATION OF JOINT SEALANTS

- A. General: Comply with joint-sealant manufacturer's written installation instructions for products and applications indicated, unless more stringent requirements apply.
- B. Sealant Installation Standard: Comply with recommendations in ASTM C1193 for use of joint sealants as applicable to materials, applications, and conditions indicated.
- C. Install sealant backings of kind indicated to support sealants during application and at position required to produce cross-sectional shapes and depths of installed sealants relative to joint widths that allow optimum sealant movement capability.
 - 1. Do not leave gaps between ends of sealant backings.
 - 2. Do not stretch, twist, puncture, or tear sealant backings.
 - 3. Remove absorbent sealant backings that have become wet before sealant application and replace them with dry materials.
- D. Install bond-breaker tape behind sealants where sealant backings are not used between sealants and backs of joints.
- E. Install sealants using proven techniques that comply with the following and at the same time backings are installed:
 - 1. Place sealants so they directly contact and fully wet joint substrates.
 - 2. Completely fill recesses in each joint configuration.
 - 3. Produce uniform, cross-sectional shapes and depths relative to joint widths that allow optimum sealant movement capability.
- F. Tooling of Nonsag Sealants: Immediately after sealant application and before skinning or curing begins, tool sealants according to requirements specified in subparagraphs below to form smooth, uniform beads of configuration indicated; to eliminate air pockets; and to ensure contact and adhesion of sealant with sides of joint.
 - 1. Remove excess sealant from surfaces adjacent to joints.
 - 2. Use tooling agents that are approved in writing by sealant manufacturer and that do not discolor sealants or adjacent surfaces.
 - 3. Provide concave joint profile per Figure 8A in ASTM C1193, unless otherwise indicated.
 - 4. Provide flush joint profile where indicated per Figure 8B in ASTM C1193.

5. Provide recessed joint configuration of recess depth and at locations indicated per Figure 8C in ASTM C1193.
 - a. Use masking tape to protect surfaces adjacent to recessed tooled joints.

3.04 FIELD QUALITY CONTROL

A. Field-Adhesion Testing: Field test joint-sealant adhesion to joint substrates as follows:

1. Extent of Testing: Test completed and cured sealant joints as follows:
 - a. Perform 10 tests for the first 1000 feet of joint length for each kind of sealant and joint substrate.
2. Test Method: Test joint sealants according to Method A, Field-Applied Sealant Joint Hand Pull Tab, in Appendix X1 in ASTM C1193 or Method A, Tail Procedure, in ASTM C1521.
 - a. For joints with dissimilar substrates, verify adhesion to each substrate separately; extend cut along one side, verifying adhesion to opposite side. Repeat procedure for opposite side.
3. Inspect tested joints and report on the following:
 - a. Whether sealants filled joint cavities and are free of voids.
 - b. Whether sealant dimensions and configurations comply with specified requirements.
 - c. Whether sealants in joints connected to pulled-out portion failed to adhere to joint substrates or tore cohesively. Include data on pull distance used to test each kind of product and joint substrate. Compare these results to determine if adhesion passes sealant manufacturer's field-adhesion hand-pull test criteria.
4. Record test results in a field-adhesion-test log. Include dates when sealants were installed, names of persons who installed sealants, test dates, test locations, whether joints were primed, adhesion results and percent elongations, sealant fill, sealant configuration, and sealant dimensions.
5. Repair sealants pulled from test area by applying new sealants following same procedures used originally to seal joints. Ensure that original sealant surfaces are clean and that new sealant contacts original sealant.

B. Evaluation of Field-Adhesion Test Results: Sealants not evidencing adhesive failure from testing or noncompliance with other indicated requirements will be considered satisfactory. Remove sealants that fail to adhere to joint substrates during testing or to comply with other requirements. Retest failed applications until test results prove sealants comply with indicated requirements.

3.05 CLEANING

- A. Clean off excess sealant or sealant smears adjacent to joints as the Work progresses by methods and with cleaning materials approved in writing by manufacturers of joint sealants and of products in which joints occur.

3.06 PROTECTION

- A. Protect joint sealants during and after curing period from contact with contaminating substances and from damage resulting from construction operations or other causes so sealants are without deterioration or damage at time of Substantial Completion. If, despite such protection, damage or deterioration occurs, cut out and remove damaged or deteriorated joint sealants immediately so installations with repaired areas are indistinguishable from original work.

3.07 CONTRACT CLOSEOUT

- A. Provide in accordance with Section 017700.

END OF SECTION 079200

SECTION 083326 - OVERHEAD COILING GRILLES

PART 1 - GENERAL

1.01 RELATED DOCUMENTS

- A. Drawings and general provisions of the Contract, including General and Supplementary Conditions and Division 01 Specification Sections, apply to this Section.

1.02 PAYMENT

- A. No separate payment shall be made for performing any Work required under this Section. All costs for Work required by this Section shall be included in the applicable lump sum(s), unit price(s), or allowance(s) as set forth in Section 012901.

1.03 SUMMARY

- A. Section Includes:
 - 1. Open-curtain overhead coiling grilles.

1.04 RELATED SECTIONS

- A. General Conditions Section 4.7 – Shop Drawings and Other Submittals
- B. Section 012901 – Measurement and Payment
- C. Section 014300 – Quality Requirements
- D. Section 016100 – Control of Materials
- E. Requirements from the following section also apply to this Section
 - 1. Section 055000 - Miscellaneous Metals

1.05 SUBMITTALS

- A. Submit the following information in accordance with General Conditions Article 4.7.
- B. Product Data: For each type and size of overhead coiling grille and accessory.
 - 1. Include construction details, material descriptions, dimensions of individual components, profiles for curtain components, and finishes.

2. Include rated capacities, operating characteristics, electrical characteristics, and furnished accessories.
- C. Shop Drawings: For each installation and for special components not dimensioned or detailed in manufacturer's product data.
1. Include plans, elevations, sections, and mounting details.
 2. Include details of equipment assemblies. Indicate dimensions, required clearances, method of field assembly, components, and location and size of each field connection.
 3. Include points of attachment and their corresponding static and dynamic loads imposed on structure.
 4. For exterior components, include details of provisions for assembly expansion and contraction.
 5. Show locations of controls, locking devices, and other accessories.
 6. Include diagrams for power, signal, and control wiring.
- D. Samples for Verification: For each type of exposed finish on the following components, in manufacturer's standard sizes:
1. Open-curtain grille with full-size components consisting of rods, spacers, and links as required to illustrate each assembly.
 2. Bottom bar with sensor edge.
 3. Guides.
 4. Mounting frame.
 5. Brackets.
 6. Hood.
 7. Numeric keypad actuator.
- E. Qualification Data: For Installer.
- F. Sample Warranty: For special warranty.
- G. Maintenance Data: For overhead coiling grilles to include in maintenance manuals.

1.06 QUALITY ASSURANCE

- A. Comply with the requirements specified in Section 014300.
- B. Installer Qualifications: An entity that employs installers and supervisors who are trained and approved by manufacturer for both installation and maintenance of units required for this Project.
- C. Accessibility Standard: Comply with applicable provisions in the USDOJ's "2010 ADA Standards for Accessible Design" and ICC A117.1.

1.07 WARRANTY

- A. Special Warranty: Manufacturer agrees to repair or replace components of grilles that fail in materials or workmanship within specified warranty period.
 - 1. Warranty Period: Two years from date of Substantial Completion.

PART 2 - PRODUCTS

2.01 MANUFACTURERS

- A. Source Limitations: Obtain overhead coiling grilles from single source from single manufacturer.
 - 1. Obtain operators and controls from overhead coiling-grille manufacturer.

2.02 PERFORMANCE REQUIREMENTS

- A. Seismic Performance: Overhead coiling grilles shall withstand the effects of earthquake motions determined according to ASCE/SEI 7.

2.03 OPEN-CURTAIN GRILLE ASSEMBLY – OBSERVER HIGHWAY LOCATION

- A. Open-Curtain Grille: Overhead coiling grille with a curtain having a network of horizontal rods that interconnect with vertical links.
 - 1. The following manufactures and product systems shall be construed to mean the establishing of a minimum quality and performance standards for the specified item. Overhead Door Corporation Model 671 with RHX Operator NEMA 4X
 - 2. United Steel Products
 - 3. Cornell Iron

4. Or approved equal
- B. Operation Cycles: Grille components and operators capable of operating for not less than 300,000. One operation cycle is complete when a grille is opened from the closed position to the fully open position and returned to the closed position.
 1. Include tamperproof cycle counter.
- C. Grille Curtain Material: Stainless steel.
 1. Rod Spacing: Approximately 2 inches (51 mm) o.c.
 2. Link Spacing: Approximately 9 inches (228 mm) apart in a straight in-line pattern.
 3. Spacers: Metal tubes matching curtain material.
- D. Bottom Bar: Continuous doubled angles, fabricated from stainless steel and finished.
- E. Curtain Jamb Guides: Stainless steel with exposed finish matching curtain slats. Provide continuous integral wear strips to prevent metal-to-metal contact and to minimize operational noise.
- F. Hood: Stainless steel.
 1. Shape: Provide with sloped top for exterior mounting.
 2. Mounting: As indicated on Contract Drawings.
- G. Electric Grille Operator:
 1. Usage Classification: Heavy duty, 25 or more cycles per hour and more than 90 cycles per day.
 2. Operator Location: As indicated on Contract Drawings.
 3. Motor Exposure: Provide NEMA 4X for Exterior, wet, humid and corrosive environments.
 4. Compliance with UL 325 2010
 5. Motor Electrical Characteristics:
 - a. Horsepower: As required for size, weight and indicated speed of grille.
 - b. Voltage: 208-V ac, three phase, 60 Hz.

6. Emergency Manual Operation: Crank type.
7. Obstruction-Detection Device: Automatic photoelectric sensor, and self-monitoring electric sensor edge on bottom bar.
 - a. Sensor Edge Bulb Color: Black/yellow striped.
8. Control Station: Where indicated on Contract Drawings.
9. Other Equipment:
 - a. Audible and visual signals.
 - b. Automatic stop lock brake to eliminate uncontrolled curtain travel independent of other safeties.

H. Grille Finish:

1. Stainless-Steel Finish: No. 4 (polished directional satin).

2.04 MATERIALS, GENERAL

- A. Comply with the requirements specified in Section 016100.
- B. Electrical Components, Devices, and Accessories: Listed and labeled as defined in NFPA 70, by a qualified testing agency, and marked for intended location and application.

2.05 GRILLE CURTAIN MATERIALS AND CONSTRUCTION

- A. Open-Curtain Grilles: Fabricate metal grille curtain as an open network of horizontal rods, spaced at regular intervals, that are interconnected with vertical links, which are formed and spaced as indicated and are free to rotate on the rods.
 1. Stainless-Steel Grille Curtain: ASTM A666 or ASTM A240/A240M, Type 300 series.
- B. Grille Curtain Jamb Guides: Manufacturer's standard shape having curtain groove with return lips or bars to retain curtain. Provide continuous integral wear strips to prevent metal-to-metal contact and to minimize operational noise; with removable stops on guides to prevent overtravel of curtain.

2.06 HOODS AND ACCESSORIES

- A. General: Form sheet metal hood to entirely enclose coiled curtain on all sides, top, bottom, ends and front and back, and operating mechanism at opening head. Contour to

fit end brackets to which hood is attached. Roll and reinforce top and bottom edges for stiffness. Form closed ends for surface-mounted hoods and fascia for any portion of between-jamb mounting that projects beyond wall face. Equip hood with intermediate support brackets as required to prevent sagging.

1. Stainless Steel: 0.025-inch- (0.64-mm-) thick, stainless-steel sheet, Type 316, complying with ASTM A666 or ASTM A240/A240M.

2.07 DOOR ROLL

A. Directly Driven Springless Roll

1. Steel tube with integral shafts, keyed on drive end and supported by self-aligning greaseable sealed bearings.
2. Door shall not require any counterbalance device.

2.08 ELECTRIC GRILLE OPERATORS

A. General: Electric grille operator assembly of size and capacity recommended and provided by grille manufacturer for grille and operation cycles requirement specified, with electric motor and factory-prewired motor controls, starter, gear-reduction unit, solenoid-operated brake, clutch, control stations, control devices, integral gearing for locking grille, and accessories required for proper operation.

1. Comply with NFPA 70.
2. Control equipment complying with NEMA ICS 1, NEMA ICS 2, and NEMA ICS 6, with NFPA 70 Class 2 control circuit, maximum 24-V ac or dc.

B. Usage Classification: Electric operator and components capable of operating for not less than number of cycles per hour indicated for grille.

C. Grille Operator Location: Operator location indicated for grille.

D. Motors: Direct drive, hypoid gear motor/brake assembly with controller (disconnect switch) for motor exposure indicated for grille assembly. Provide factory pre-assembled operator and drive assembly with low-voltage factory wiring with quick connect wiring harnesses.

1. Electrical Characteristics: Minimum as indicated for each grille assembly. If not indicated, large enough to start, accelerate, and operate grille in either direction from any position, at a speed not less than 20 in./sec. (508 mm/s) upward and not more than 12 in./sec. (305 mm/s), without exceeding nameplate ratings or service factor.

2. Operating Controls, Controllers (Disconnect Switches), Wiring Devices, and Wiring: Manufacturer's standard unless otherwise indicated.
 3. Coordinate wiring requirements and electrical characteristics of motors and other electrical devices with site/building electrical system and each location where installed.
- E. Limit Switches: Equip each motorized grille with adjustable switches interlocked with motor controls and set to automatically stop grille at fully opened and fully closed positions.
- F. Obstruction-Detection Devices: External entrapment protection consisting of indicated automatic safety sensor capable of protecting full width of grille opening. Activation of sensor immediately stops and reverses downward grille travel.
1. Photoelectric Sensor: Manufacturer's standard system designed to detect an obstruction in grille opening without contact between grille and obstruction.
 2. Electric Sensor Edge: Automatic safety sensor edge, located within astragal or weather stripping mounted to bottom bar. Contact with sensor activates device. Connect to control circuit using manufacturer's standard take-up reel or self-coiling cable.
 - a. Self-Monitoring Type: Device designed to interface with grille operator control circuit to detect damage to or disconnection of sensor edge.
- G. Control Station
1. Variable frequency drive controller with microprocessor self-diagnostics.
 2. LCD readout indicating door action, alarm conditions, and fault conditions.
 3. Time delay self-close timer and non-resettable cycle counter.
 4. Actuators:
 - a. Numeric keypad.
 - b. Loop detectors (shadow, interrupt and egress)
 5. Exterior-Mounted Units: Full-guarded, standard-duty, surface-mounted, weatherproof type; NEMA ICS 6, Type 4 enclosure, key operated.
- H. Emergency Manual Operation: Equip electrically powered grille with capability for emergency manual operation. Design manual mechanism so required force for grille operation does not exceed 25 lbf (111 N).

- I. Emergency Operation Disconnect Device: Equip operator with hand-operated disconnect mechanism for automatically engaging manual operator and releasing brake for emergency manual operation while disconnecting motor without affecting timing of limit switch. Mount mechanism so it is accessible from floor level. Include interlock device to automatically prevent motor from operating when emergency operator is engaged.
- J. Motor Removal: Design operator so motor may be removed without disturbing limit-switch adjustment and without affecting emergency manual operation.

2.09 GENERAL FINISH REQUIREMENTS

- A. Comply with NAAMM/NOMMA 500 for recommendations for applying and designating finishes.
- B. Appearance of Finished Work: Noticeable variations in same piece are not acceptable. Variations in appearance of adjoining components are acceptable if they are within the range of approved Samples and are assembled or installed to minimize contrast.

2.10 STAINLESS-STEEL FINISHES

- A. Surface Preparation: Remove tool and die marks and stretch lines, or blend into finish.
- B. Polished Finishes: Grind and polish surfaces to produce uniform finish, free of cross scratches.
 - 1. Run grain of directional finishes with long dimension of each piece.
 - 2. When polishing is completed, passivate and rinse surfaces. Remove embedded foreign matter and leave surfaces chemically clean.
 - 3. Directional Satin Finish: No. 4.

PART 3 - EXECUTION

3.01 EXAMINATION

- A. Examine substrates, areas, and conditions, with Installer present, for compliance with requirements for substrate construction and other conditions affecting performance of the Work.
- B. Examine locations of electrical connections.
- C. Proceed with installation only after unsatisfactory conditions have been corrected.

3.02 INSTALLATION

- A. Install overhead coiling grilles and operating equipment complete with necessary hardware, anchors, inserts, hangers, and equipment supports, according to manufacturer's written instructions and as specified.
- B. Install overhead coiling grilles, hoods, controls, and operators at the mounting locations indicated for each grille.
- C. Accessibility: Install overhead coiling grilles, switches, and controls along accessible routes in compliance with the accessibility standard.
- D. Power-Operated Grilles: Install according to UL 325.

3.03 STARTUP SERVICE

- A. Engage a factory-authorized service representative to perform startup service.
 - 1. Complete installation and startup checks according to manufacturer's written instructions.
 - 2. Test and adjust controls and safety devices. Replace damaged and malfunctioning controls and equipment.

3.04 ADJUSTING

- A. Adjust hardware and moving parts to function smoothly, so that grilles operate easily, free of warp, twist, or distortion.
 - 1. Adjust exterior components to be weather resistant.
- B. Lubricate bearings and sliding parts as recommended by manufacturer.

3.05 MAINTENANCE SERVICE

- A. Initial Maintenance Service: Beginning at Substantial Completion, maintenance service shall include 12 months' full maintenance by skilled employees of coiling-grille Installer. Include quarterly preventive maintenance, repair or replacement of worn or defective components, lubrication, cleaning, and adjusting as required for proper grille operation. Parts and supplies shall be manufacturer's authorized replacement parts and supplies.
 - 1. Perform maintenance, including emergency callback service, during normal working hours.
 - 2. Include 24-hour-per-day, 7-day-per-week, emergency callback service.

3.06 DEMONSTRATION

- A. Engage a factory-authorized service representative to train DEP's maintenance personnel to adjust, operate, and maintain overhead coiling grilles.

3.07 CONTRACT CLOSEOUT

- A. Refer to Section 017700

END OF SECTION 083326

SECTION 088400 - GLAZING PLASTICS

PART 1 - GENERAL

1.01 SUMMARY

- A. This Section specifies requirements for polycarbonate glazing plastics and resins indicated as LT-2 in Contract Documents.

1.02 DESIGN AND PERFORMANCE REQUIREMENTS

- A. Transmission Characteristics: Provide glazing plastics and glazing materials that have been produced, fabricated and installed to withstand normal temperature changes, wind loading and impact loading, without failure including loss or breakage of glazing plastics, failure of sealants or gaskets to remain watertight and airtight, deterioration of glazing plastic and glazing materials, and other defects in the Work.

1.03 PAYMENT

- A. No separate payment shall be made for performing any Work required under this Section. All costs for Work required by this Section shall be included in the applicable lump sum(s), unit price(s), or allowance(s) as set forth in Section 012901.

1.04 RELATED SECTIONS

- A. General Conditions Article 4.7 – Shop Drawings and Other Submittals.
- B. Section 012901 – Measurement and Payment.
- C. Section 014300 - Quality Requirements.
- D. Section 017700 - Contract Closeout.

1.05 REFERENCES

- A. ASTM International (ASTM)
 - 1. C719 - Standard Test Method for Adhesion and Cohesion of Elastomeric Joint Sealants Under Cyclic Movement (Hockman Cycle)
 - 2. C920 – Standard Specification for Elastomeric Joint Sealants
 - 3. D256 – Standard Test Methods for Impact Resistance of Plastics and Electrical Insulating Materials
 - 4. D790 – Standard Test Methods for Flexural Properties of Unreinforced and Reinforced Plastics and Electrical Insulating Materials

5. D1003 – Standard Test Method for Haze and Luminous Transmittance of Transparent Plastics
 6. D1044 – Standard Test Method for Resistance of Transparent Plastics to Surface Abrasion
- B. Code of Federal Regulations (CFR)
1. 16 CFR Part 1201– Safety Standard for Architectural Glazing Materials
- C. Federal Specifications (FS)
1. TT-S-001543 - Sealing Compound: Silicone Rubber Base (For Caulking, Sealing and Glazing in Buildings and Other Structures)

1.06 QUALITY ASSURANCE

- A. Field-Constructed Mock-Up: Where shown on the Contract Drawings, prepare mock-ups of glazing plastics in locations directed by the Engineer. Construct mock-ups to match glazing systems, including typical lite size, framing system, and glazing materials and methods. Obtain Engineer's acceptance of visual qualities before proceeding with the Work. Retain acceptable mock-ups in undisturbed condition during construction as a standard for judging completed Work.
- B. Expansion/Contraction Allowances: The following formula provides allowances that should be made in framed or fitted applications:
1. Longest length of panel (inches) x temperature change of the sheet (°F) x 0.00004 = Amount of Linear Expansion/Contraction (inches)
- C. Usage limitation: Non-metallic* gaskets, washers, and tubing are to be utilized in conjunction with mechanical connections such as point supports and frames. Holes for fasteners must be located a minimum of 2-inch from the edge of the hole to the edge of the panel. Gaskets, washers and tubing must be produced with a non-plasticized material. Suitable materials include neoprene, teflon, nylon, silicone.
- D. Fabricator Qualifications: Entities performing fabrication of polycarbonate resin sheets, including application of coating:
1. Be acceptable to the primary polycarbonate resin sheet manufacturer.
 2. Have not less than ten years' experience in polycarbonate fabrication projects involving complexities at least as complex as the polycarbonate fabrication required for the Work of this Contract.

1.07 SUBMITTALS

- A. Submit shop drawings and manufacturers' product data in accordance with General Conditions Article 4.7.

- B. General: Submittals listed in this article shall be in accordance with the requirements of "Shop Drawings, Catalog Cuts, and Samples" of Division 1 - GENERAL PROVISIONS.
- C. Product Data: Submit manufacturer's technical data for each glazing plastic and glazing material required, including installation and maintenance instructions.
- D. Samples: Submit, for verification purpose, 12 inch square samples of each type of glazing plastic shown on the Contract Drawings and 12 inch long samples of each color required (except black) for each type of sealant or gasket exposed to view. Install sealant or gasket sample between two strips of material representative of the color and/or finish, size, and profile of adjoining framing system.
- E. Certificates
 - 1. Submit certificates from respective manufacturers attesting that glazing plastic and glazing materials furnished comply with the requirements of this Section.
 - 2. Submit certification indicating compliance with paragraph 1.06 E. of this Section.
 - 3. Published product literature or letters of Certification, provided from the product manufacturer on the manufacturer's letterhead, to verify the product information.
 - 4. Product cut sheets for materials.
 - 5. Material Safety Data Sheets (MSDS), for applicable products. Applicable products include, but are not limited to field-applied adhesives, and sealants. Material Safety Data Sheets shall indicate the Volatile Organic Compound (VOC) limits of products submitted (If an MSDS does not include a product's VOC limits, then product data sheets, manufacturer literature, or a letter of certification from the manufacturer can be submitted in addition to the MSDS to indicate the VOC limits).

1.08 ENVIRONMENTAL REQUIREMENTS

- A. Do not proceed with glazing when ambient and substrate temperature conditions are outside the limits permitted by glazing material manufacturer or when joint substrates are wet due to rain, frost, condensation or other causes. Install glazing sealants only when temperatures are in middle third of manufacturer's recommended installation temperature range.
 - 1. Install liquid sealants, where shown at ambient and substrate temperature above 40 degrees F.

1.09 DELIVERY, STORAGE, AND HANDLING

- A. Comply with the requirements specified in Section 016100.
- B. Comply with manufacturer's instructions for shipping, storing and handling of glazing plastics, and for removal of protective coverings after installation. Maintain protective coverings on sheet and avoid exposures to abrasive substances, excessive heat and other sources of possible deterioration.

1.10 GUARANTY

- A. Notwithstanding the Specifications forming a part of this Contract, any inspection or approval of the Work by the Authority, or the existence of any patent or trade name, the Contractor nevertheless unconditionally guaranties that the glazing plastic furnished and installed hereunder shall be of the best quality and shall be fully fit for the purpose for which it is intended. The Contractor unconditionally guaranties all glazing plastic furnished and installed by it against defects or failures of any kind, including defects or failures in design, workmanship and materials, including yellowing or changing color noticeably, losing strength, losing impact or abrasion resistance, or deteriorating appreciably in other ways related to intended applications, excepting such defects or failures which the Contractor demonstrates to the satisfaction of the Engineer have arisen solely from accident, abuse or fault on the part of the Authority occurring after issuance of the Certificate of Final Completion for this Contract and not due to fault on the Contractor's part, for a period of three years from the issuance of such Certificate. In the event of defects or failures in plastic glazing sheet(s), upon receipt of notice thereof from the Engineer, the Contractor shall correct such defects or failures by immediately replacing the affected plastic glazing sheet(s) as may be necessary or desirable in the sole opinion of the Engineer to comply with the above guaranty.
- B. The foregoing guaranty shall not, however, be a limitation on any rights which the Authority would have, either expressed or implied, in connection with this Contract in the absence of such guaranty, in the case of a breach of Contract by the Contractor, the said guaranty being given only for the greater assurance of the Authority.

PART 2 - PRODUCTS

2.01 MATERIALS

- A. Polycarbonate Glazing Plastic: Provide polycarbonate sheets with a minimum flexural strength of 13,500 psi per ASTM D790, at 240 degrees F allowable continuous service temperature, and Izod impact strength of 16 ft-lb per inch per ASTM D256; in sizes shown on the Contract Drawings and thicknesses indicated in this Section and complying with the following requirements:

- 1. Color and Finish:

- a. Color: 3-form Helium N48 or equivalent. Submit samples to be reviewed by architect.
- b. Finish: Matte
2. Thickness shall be 1/2 inch, unless otherwise shown on the Contract Drawings.

B. Glazing Sealants

1. General: Comply with the recommendations of sealant and glazing plastic manufacturers for selection of glazing sealants which have performance characteristics suitable for applications shown on the Contract Drawings and conditions at time of installation.
2. Compatibility: Select sealants with proven compatibility with surfaces contacted in the installation and under service conditions shown on the Contract Drawings, as demonstrated by testing and field experience.
3. Colors: Provide color of exposed sealants shown on Contract Drawings or, if not otherwise shown, as selected by the Engineer from the manufacturer's standard colors.
4. Silicone Glazing Sealant (where shown on Contract Drawings):
 - a. Single-component elastomeric silicone sealant complying with FS TT-S-001543, Class A, nonsag; and with ASTM C920 Type S, Grade NS, Class 25, Use G and, as applicable to use shown on the Contract Drawings, Uses A and 0; and with the following requirements:
 - (1) Low Modulus Silicone Glazing Sealant: Manufacturer's standard low-modulus non-acid curing sealant that can withstand an increase of 100 percent and decrease of 50 percent of joint width as measured at time of application when tested per ASTM C719.
5. Subject to compliance with the requirements of this Section, provide one of the following, or approved equal:
 - a. "Dow Corning 790"; Dow Corning Corp., Midland, MI
 - b. "Gesil N"; General Electric Co., Silicone Products Div., Waterford, NY
 - c. "Silglaze"; General Electric Co.
 - d. "Silpruf"; General Electric Co.
 - e. Silicone Building Sealant by Pecora Corporation.

C. Miscellaneous Glazing

1. Compatibility: Provide materials with proven record of compatibility with surfaces contacted in installation and under service conditions shown on the Contract Drawings, as demonstrated by testing and field experience.
2. Cleaners, primers, and sealers shall be the type recommended by the sealant manufacturer.
3. Setting Blocks: Neoprene, EPDM or silicone blocks as required for compatibility with glazing sealant and glazing plastic, 80 to 90 Shore A durometer hardness.
4. Compression Filler Rods: Closed-cell or waterproof-jacketed rod stock of synthetic rubber or plastic foam, flexible and resilient, with 5-10 psi compression strength for 25 percent deflection.

2.02 MANUFACTURERS

- A. Subject to compliance with the requirements of this Section, provide products of one of the following manufacturers or approved equal:
1. “Chroma XT”, 3-Form 2300 South 2300 West Salt Lake City, UT 84119.
 2. Lumicor, Inc.
 3. ePlastic, Inc.

2.03 FABRICATION

- A. Sizes: Fabricate glazing plastics to sizes required for glazing openings shown on the Contract Drawings and to allow for thermal expansion and contraction of glazing plastic without restraint and without withdrawal of edges from frames, with edge clearances and tolerances complying with recommendations of glazing plastic manufacturer. Provide thicknesses required in this Section or shown on the Contract Drawings, or, if not otherwise required or shown, as recommended by glazing plastic manufacturer for application shown.
- B. Curved sheets, where shown on the Contract Drawings, shall be shop fabricated from uncoated sheet. Shape sheets to required radii under heat, then, post-coat both faces with a heat applied silicone coating for abrasion resistance. Clearness and tint of finished sheets shall be identical to the flat sheets specified in this Section.

PART 3 - EXECUTION

3.01 PREPARATION

- A. Pre-Installation Meeting: Arrange for the glazier, sealant and gasket manufacturers' technical representatives, glazing plastic framing erector and other trades whose Work affects glazing plastics and glazing meet at a time to be specified by the Engineer at the construction site to review the procedures and the time schedule proposed for glazing so as to assure coordination with other Work.
- B. Clean glazing channels and other framing members to receive glazing plastics immediately before glazing. Remove coatings that are not firmly bonded to substrates. Remove lacquer from metal surfaces at elastomeric sealants locations as shown on the Contract Drawings.

3.02 INSTALLATION

A. General

- 1. Comply with combined printed recommendations of manufacturers of glazing plastic and of sealants, gaskets and other glazing materials, except where more stringent requirements are specified in this Section including those of referenced glazing standards.
- 2. Glazing channel dimensions as shown on the Contract Drawings are intended to provide for necessary bite on glazing plastics, minimum edge and face clearances, and adequate sealant thicknesses, with reasonable tolerances. Adjust as required by job conditions at the time of installation.
- 3. Protect plastic surfaces from abrasion and other damage during handling and installation by retaining manufacturer's protective covering, or by other protective methods recommended by the glazing plastic manufacturer. Remove covering at the border of each piece prior to glazing, remove remainder of covering immediately after installation where glazing plastic will be exposed to sunlight or other conditions where later removal will be difficult.
- 4. Apply primers to joint surfaces where required for adhesion of sealants, as determined by preconstruction sealant-substrate testing.

B. Glazing

- 1. Provide compressible filler rods or equivalent back-up material, as recommended by sealant and glazing plastic manufacturers, to prevent sealant from exuding into glazing channel weep systems and from adhering to joint's back surface as well as to control depth of sealant for optimum performance, unless otherwise shown on the Contract Drawings.

2. Force sealants into glazing channels to eliminate voids and to ensure complete “wetting” or bond of sealant to glazing plastic and channel surfaces.
3. Tool exposed surfaces of sealants to provide a substantial “wash” way from glazing plastics. Install pressurized tapes and gaskets to protrude slightly out of channel, so as to eliminate dirt and moisture pockets.
4. Where wedge-shaped gaskets are driven into one side of channel to pressurize sealant or gasket on opposite side, provide adequate anchorage to ensure that gasket will not “walk” out when installation is subject to movement.
5. Miter cut wedge-shaped gaskets at corners and install gaskets in manner recommended by gasket manufacturer to prevent pull away at corners; seal corner joints and butt joints with sealant recommended by gasket manufacturer.

3.03 PROTECTION

- A. Protect glazing plastic from contact with contaminating substances resulting from construction operations. If, despite such protection, contaminating substances do come into contact with glazing plastic, remove immediately by washing method recommended by the glazing plastic manufacturer.
- B. Remove and replace glazing plastic which is broken, chipped, cracked, abraded or damaged in other ways prior to the issuance of the Certificate of Final Completion, including natural causes, accidents and vandalism.
- C. Wash glazing plastic on both faces not more than four days prior to final inspection. Wash glazing plastic by method recommended by the glazing plastic manufacturer.

3.04 CONTRACT CLOSEOUT

- A. Provide in accordance with Section 017700.

END OF SECTION 088400

SECTION 099110 - SHOP PAINTING

PART 1 - GENERAL

1.01 DESCRIPTION

- A. Provide shop painting as specified and in compliance with Contract Documents.

1.02 PAYMENT

- A. No separate payment shall be made for performing any Work required under this Section. All costs for Work required by this Section shall be included in the applicable lump sum(s), unit price(s), or allowance(s) as set forth in Section 012901.

1.03 REFERENCES

- A. ASTM International (ASTM):

1. B117: Standard Practice for Operating Salt Spray (Fog) Apparatus;
2. D2247: Standard Practice for Testing Water Resistance of Coatings in 100% Relative Humidity;
3. D2794: Standard Test Method for Resistance of Organic Coatings to the Effects of Rapid Deformation (Impact);
4. D4414: Standard Practice for Measurement of Wet Film Thickness by Notch Gages;
5. D4541: Standard Test Method for Pull-Off Strength of Coatings Using Portable Adhesion Testers;
6. D5162: Standard Practice for Discontinuity (Holiday) Testing of Nonconductive Protective Coating on Metallic Substrates;
7. D7091: Standard Practice for Nondestructive Measurement of Dry Film Thickness of Nonmagnetic Coatings Applied to Ferrous Metals and Nonmagnetic, Nonconductive Coatings Applied to Non-Ferrous Metals.

- B. The Society for Protective Coatings (SSPC):

1. SP3: Power Tool Cleaning;
2. SP6: Commercial Blast Cleaning;
3. SP10: Near-White Blast Cleaning.

1.04 RELATED SECTIONS

- A. General Conditions Article 4.7 – Shop Drawings and Other Submittals
- B. Section 012901 – Measurement and Payment
- C. Section 014300 - Quality Requirements
- D. Section 016100 – Control of Materials
- E. Section 017700 - Contract Closeout

1.05 SUBMITTALS

- A. Submit the following shop drawings in accordance with General Conditions Article 4.7.
- B. Manufacturer's specifications and data of all products of the proposed coating system.
- C. Manufacturer's detailed requirements for surface preparation, application procedures and dry mil thicknesses.

1.06 QUALITY ASSURANCE

- A. Comply with the requirements specified in Section 014300.

1.07 DELIVERY STORAGE AND HANDLING

- A. Comply with the requirements specified in Section 016100.
- B. Deliver materials to application area in original, unbroken containers, plainly marked with name and analysis of product, manufacturer's name, and shelf life date. Do not store or use contaminated, outdated, prematurely opened, or diluted materials.
- C. Store coated items to prevent damage or dirtying of coatings. Avoid need for special cleaning, and store coated items out of contact with ground or pavement. Place suitable blocking under coated items during storage.
- D. Do not expose surfaces to weather for more than six months before being topcoated, or less time if recommended by coating manufacturer.
- E. Protect surfaces not to receive paint coatings during surface preparation, cleaning, and painting.
- F. Protect coatings from damage during shipment and handling by padding, blocking, use canvas or nylon slings, and use care when handling.

- G. At time of delivery of shop painted items to job site, ensure coatings are undamaged and in good condition.

1.08 PROJECT/SITE CONDITIONS

- A. Environmental Requirements:
 - 1. Comply with manufacturer's recommendations as to environmental conditions under which coatings and coating systems can be applied.
 - 2. Do not apply coatings when dust is being generated.

1.09 GENERAL REQUIREMENTS

- A. No paint should be applied to surfaces in contact with concrete. However, these surfaces must be thoroughly cleaned and free of rust, scale, grease and any other material that may affect the adhesion of the concrete.
- B. All surface preparations and paint applications must be done in the workshop. Any damage during handling, transport, and assembly shall be repaired on site by the Contractor at no cost to the NJDEP. Any alterations to the site must comply with the requirements of this Section.
- C. The use of silica as an abrasive is not acceptable.

PART 2 - PRODUCTS

2.01 MATERIALS

- A. All coating used for a system shall come from the same manufacturer.
- B. Prior to do the work Contractor to supply manufacturer coating spec sheet to the Architect/Engineer for review.
- C. The approved shop coating system for gates shall be as follows:
 - 1. First coat:
 - a. Type: Surface Tolerant Epoxy (two components)
 - b. Product: AkzoNobel, International Interseal 670HS
 - c. Thickness: 125 - 250 microns (5.0 – 10.0 mils) dry
 - d. Color: Different color of the second coat

2. Second coat:
 - a. Type: Surface Tolerant Epoxy (two components)
 - b. Product: AkzoNobel, International Interseal 670HS
 - c. Thickness: 125 - 250 microns (5.0 – 10.0 mils) dry
 - d. Color: Different color of the topcoat
3. Topcoat:
 - a. Type: Acrylic Polyurethane (two components)
 - b. Product: AkzoNobel, International Interthane 870
 - c. Thickness: 75 - 125 microns (3.0 – 5.0 mils) dry
 - d. Color: To be provided by the NJDEP after contract award.

D. The approved shop coating system for Bridge Hollow Steel Sections Girder, beams and Columns shall be as follows, (Carboline), Rustoleum, Benjamin Moore Corotech, or approved equal coating system:

1. Primer coat:
 - a. Type: Organic Zinc Rich Epoxy
 - b. Product: Carboline - Carbozinc 859
 - c. Thickness: 76 - 127 microns (3.0 – 5.0 mils) dry
 - d. Color: Different color of the second coat
2. Second coat:
 - a. Type: Epoxy
 - b. Product: Carboline - Carboguard 954 HB
 - c. Thickness: 76 - 305 microns (3.0 – 12.0 mils) dry
 - d. Color: Different color of the topcoat
3. Topcoat:
 - a. Type: Aliphatic Polyurethane Gloss

- b. Product: Carboline - Carbothane 134 WB
- c. Thickness: 51 - 64 microns (2.0 – 2.5 mils) dry
- d. Color: Metallic Silver, color chip to be provided by Architect/Engineer

E. Performance Data:

- 1. ASTM- D4541 - Adhesion – No less than 1500 psi pull
- 2. ASTM- D2247 - Humidity- No rusting, blistering or cracking after 3500 hours
- 3. ASTM- B117 - Salt Spray- Minimum 14,000 hours with no blistering, rusting or cracking, and no >1/32 creep after 3000 hours
- 4. ASTM- D2794 – Impact Resistance – 75 inch/lbs (Direct)

PART 3 - EXECUTION

3.01 APPLICATION

A. Surface Preparation:

- 1. Painted and coated surfaces shall be prepared to manufacturer's recommendation, or as specified below, whichever is more stringent, as accepted by Construction Manager.
- 2. Rough welds and sharp edges shall be smoothed by grinding and weld spatter shall be removed.
- 3. Uncoated and/or machined surfaces shall be adequately protected before sandblast.
- 4. The surface shall be blast cleaned in accordance with SSPC-SP-10, Near White.
- 5. The sand blasted surfaces shall be inspected to visual standard SSPC-VIS 1.

B. Coating:

- 1. The coating must be applied within a maximum of 8 hours after blasting and cleaning.
- 2. Surface temperature during application should be at least 3 degrees Celsius above dew point.
- 3. Relative humidity during application and curing should not exceed 85 percent.

4. The application and the drying time shall comply with the paint manufacturer's recommendations.
5. Method of coating shall assure the uniform coating and shall avoid any excess of coating due to local accumulations and drips.
6. If problems of excess coating arise Construction Manager can require removing all coatings and recoating and shall be at Contractor's expense. Taking Wet Film Thickness measurement during coating application is recommended.
7. All coats shall be of a different color than the others to make a full application easier.
8. Instrument calibration, measurement of the dry film thickness, and the acceptance criteria shall be performed according to SSPC-PA 2.

C. Touch Ups:

1. All coating touch-ups shall be done according to the coating system and the requirements detailed in this Contract Section, except with regards to surface preparation and visual inspection.
2. The surface preparation shall be done by power tool according to the requirements of SSPC-SP3.
3. Visual inspection shall be done according to the requirements of SSPC-VIS 1 SP3.
4. In the case of major touch-up to be done on Site, Construction Manager may require that surface preparation be done by sand blasting.
5. For coating touch-ups after completion, Contractor shall supply to Construction Manager, 5 US Gallons of each type and color of the same paint as used.

3.02 COATING INSPECTION

- A. Paint inspection and report to be done by NACE level 2 certified inspector. Surface preparation inspection shall be done immediately prior to the coating application in the presence of an authorized representative of Construction Manager.
- B. For each coating layer, Contractor shall obtain authorization from NACE level 2 technician before proceeding with its application.
- C. The coated surface, after all coating is completed, is subject to acceptance by Construction Manager.

3.03 CONTRACT CLOSEOUT

- A. Provide in accordance with Section 017700.

END OF SECTION 099110

NO TEXT ON THIS PAGE

SECTION 099702 - COAL TAR EPOXY SYSTEM

PART 1 - GENERAL

1.01 DESCRIPTION

- A. Provide coal tar epoxy coatings for steel sheet piling, steel H-piles and micropiles as shown on the Contract Drawings and specified herein.

1.02 PAYMENT

- A. No separate payment shall be made for performing any Work required under this Section. All costs for Work required by this Section shall be included in the applicable lump sum(s), unit price(s), or allowance(s) as set forth in Section 012901.

1.03 REFERENCES

- A. The publications listed below form a part of this specification to the extent referenced. The publications are referred to within the text by the basic designation only.
 1. AMERICAN NATIONAL STANDARDS INSTITUTE (ANSI)
ANSI Z358.1 (2004) Standard for Emergency Eyewash and Shower Equipment
 2. AMERICAN SOCIETY OF SAFETY ENGINEERS (ASSE/SAFE)
ASSE/SAFE Z87.1 (2003) Standard for Occupational and Educational Eye and Face Protection
 3. ASTM INTERNATIONAL (ASTM)
ASTM D7091 (2012) Standard Practice for Nondestructive Measurement of Dry Film Thickness of Nonmagnetic Coatings Applied to Ferrous Metals and Nonmagnetic, Nondestructive Coatings Applied to Non-Ferrous Metals
ASTM D843 (2011) Standard Specification for Nitration Grade Xylene
 4. NATIONAL FIRE PROTECTION ASSOCIATION (NFPA)
NFPA 70 (2011; Errata 2 2012) National Electrical Code
 5. NATIONAL INSTITUTE FOR OCCUPATIONAL SAFETY AND HEALTH (NIOSH)
NIOSH 98-119 (1998; 4th Ed) Supplement 2 to NIOSH Manual of Analytical Methods
 6. THE SOCIETY FOR PROTECTIVE COATINGS (SSPC)

- | | | |
|--|---------------|---|
| | SSPC Paint 16 | (2006) Coal Tar Epoxy-Polyamide Black (or Dark Red) Paint |
| | SSPC SP 1 | (1982; E 2004) Solvent Cleaning |
7. U.S. ARMY CORPS OF ENGINEERS (USACE)
EM 385-1-1 (2008; Errata 1-2010; Changes 1-3 2010; Changes 4-6 2011; Change 7 2012) Safety and Health Requirements Manual
 8. U.S. NATIONAL ARCHIVES AND RECORDS ADMINISTRATION (NARA)
 - 29 CFR 1910 Occupational Safety and Health Standards
 - 29 CFR 1910.134 Respiratory Protection
 - 29 CFR 1910.146 Permit-required Confined Spaces
 - 29 CFR 1910.20 Access to Employee Exposure and Medical Records
 - 29 CFR 1910.94 Ventilation
 - 29 CFR 1926 Safety and Health Regulations for Construction
 - 29 CFR 1926.62 Lead
 - 40 CFR 50.6 National Primary and Secondary Ambient Air Quality Standards for PM10
 - 40 CFR 58 Ambient Air Quality Surveillance
- 1.04 RELATED SECTIONS
- A. General Conditions Article 4.7 – Shop Drawings and Other Submittals
 - B. Section 012901 – Measurement and Payment
 - C. Section 015713 - Erosion Control, Sedimentation and Containment of Construction Materials.
 - D. Section 017700 - Contract Closeout
- 1.05 SUBMITTALS
- A. Submit the following in accordance with General Conditions Article 4.7
 - B. Product Data

1. Safety and Health Provisions
2. An Accident Prevention Plan in accordance with the requirements of Section 01 of EM 385-1-1. The plan shall include, but is not limited to, each of the topic areas listed in Appendix A therein and the specified requirements; each topic shall be developed in a concise manner to include management and operational aspects. This shall be submitted as part of the Health and Safety Plan.
3. Confined Spaces
 - a. Detailed written standard operating procedures for confined spaces in accordance with 29 CFR 1910.146 and EM 385-1-1, Section 34. This shall be submitted as part of the Health and Safety Plan. The procedures shall include:
 - (1) Certificates of calibration for all testing and monitoring equipment. The certificates of calibration shall include: type of equipment, model number, date of calibration, firm conducting calibration, and signature of individual certifying calibration.
 - (2) Methods of inspection of personal protective equipment prior to use.
 - (3) Work practices and other engineering controls designed to reduce airborne hazardous chemical exposures to a minimum.
 - (4) Specification of the design and installation of ventilation systems which shall provide adequate oxygen content and provide for the dilution of paint solvent vapor, lead, and other toxic particulates within the confined space. In addition, the Contractor shall include plans to evaluate the adequacy of air flow patterns.
4. Respirators
 - a. A comprehensive written respiratory protection program in accordance with 29 CFR 1910.134, 29 CFR 1926.62, and Section 05.G of EM 385-1-1. This shall be submitted as part of the Health and Safety Plan.
5. Certified Laboratory
 - a. An Airborne Sampling Plan detailing the NIOSH 98-119, Factory Mutual, or Underwriters Laboratories approved equipment, equipment calibration procedures, sampling methods, sampling to be performed, and analytical procedures to be used based on the type of work to be performed and anticipated toxic contaminants to be generated. The Contractor shall include the name of the accredited, certified laboratory listed by the American

Industrial Hygiene Association (AIHA), to be used to conduct the analysis of any collected air samples.

6. Ventilation
 - a. A plan to provide ventilation assessment. This shall be submitted as part of the Health and Safety Plan.
7. Medical Status
 - a. A Medical Surveillance Plan and a statement from the examining physician indicating the name of each employee evaluated and any limitations which will preclude the employee from performing the work required. The statement shall include the date of the medical evaluation, the physician's name, signature, and telephone number. This shall be submitted as part of the Health and Safety Plan.
8. PM-10 Monitoring
 - a. A plan for monitoring emissions of particulate matter 10 microns or less in size (PM-10). The plan shall comply with the requirements of EPA regulation 40 CFR 50.6 and paragraph PM-10 Monitoring. The plan shall also include provisions for halting work and correcting the containment in the event unacceptable emissions occur. This shall be submitted as part of the Health and Safety Plan.
9. Test Reports
 - a. PM-10 Monitoring
 - (1) Reports of the PM-10 monitoring tests.
 - b. Certified Laboratory
 - (1) Reports of airborne sampling tests.
10. Inspection
 - a. Records of inspections and operations performed. Submittals shall be made on a daily basis.
11. Certificates
 - a. Qualifications

(1) Certification for all job sites. Submittal of the qualifications and experience of any additional qualified and competent persons employed to provide on-site environmental, safety, and health shall also be provided. Acceptance of this submission must be obtained prior to the submission of other required environmental, safety, and health submittal items.

b. Coating Thickness Gage Qualification

(1) Documentation of manufacturer's certification shall be submitted for all coating thickness gages.

1.06 QUALIFICATIONS

A. Qualifications and experience shall comply with the following.

1. Certified Professional

a. The Contractor shall utilize a qualified and competent person as defined in Section 01 of EM 385-1-1 to develop the required safety and health submittal and to provide on-site safety and health services during the contract period. The person shall be a Certified Industrial Hygienist (CIH), an Industrial Hygienist (IH), or a Certified Safety Professional (CSP) with a minimum of 3 years of demonstrated experience in similar related work. The Contractor shall certify that the Certified Industrial Hygienist (CIH) holds current and valid certification from the American Board of Industrial Hygiene (ABIH), that the IH is considered board eligible by written confirmation from the ABIH, or that the CSP holds current and valid certification from the American Board of Certified Safety Professionals. The CIH, IH, or CSP may utilize other qualified and competent persons, as defined in EM 385-1-1, to conduct on-site safety and health activities as long as these persons have a minimum of two (2) years of demonstrated experience in similar related work and are under the direct supervision of the CIH, IH, or CSP. For lead containing jobsites, the competent and qualified person shall have successfully completed an EPA or state accredited lead-based paint abatement Supervisor course specific to the work to be performed and shall possess current and valid state and/or local government certification, as required.

2. Coating Thickness Gage Qualification

a. Documentation of certification shall be submitted for all coating thickness gages. Magnetic flux thickness gages as described in ASTM D7091 shall be used to make all coating thickness measurements on ferrous metal substrates.

Gages shall have an accuracy of +/- 3 percent or better. Gages to be used on the job shall be certified by the manufacturer as meeting these requirements.

1.07 SAMPLING AND TESTING

- A. The Contractor shall allow at least 30 days for sampling and testing. Sampling may be at the jobsite or source of supply. The Contractor shall notify the Construction Manager when the paint and thinner are available for sampling. Sampling of each batch shall be witnessed by the Construction Manager unless otherwise specified or directed. A 1-quart sample of paint and thinner shall be submitted for each batch proposed for use. The sample shall be labeled to indicate formula or specification number and nomenclature, batch number, batch quantity, color, date made, and applicable project contract number. Testing will be performed by the Contractor. Costs for retesting rejected material will be deducted from payments to the Contractor at the rate of \$300.00 dollars for each sample retested.

1.08 SAFETY AND HEALTH PROVISIONS

- A. Work shall be performed in accordance with the requirements of 29 CFR 1910, 29 CFR 1926, EM 385-1-1, and other references as listed herein. Matters of interpretation of the standards shall be submitted to the Construction Manager for resolution before starting work. Where the regulations conflict, the most stringent requirements shall apply. Paragraph 1.07 "SAFETY AND HEALTH PROVISIONS" supplements the requirements of EM 385-1-1, paragraph (1). In any conflict between Section 01 of EM 385-1-1 and this paragraph, the provisions herein shall govern.

1. Abrasive Blasting

- a. The Contractor shall comply with the requirements in Section 06.H of EM 385-1-1.

(1) Hoses and Nozzles

- a. In addition to the requirements in Section 20 of EM 385-1-1, hoses and hose connections of a type to prevent shock from static electricity shall be used. Hose lengths shall be joined together by approved couplings of a material and type designed to prevent erosion and weakening of the couplings. The couplings and nozzle attachments shall fit on the outside of the hose and shall be designed to prevent accidental disengagement.

(2) Workers Other Than Blasters

- a. Workers other than blasting operators working in close proximity to abrasive blasting operations shall be protected by

utilizing MSHA/NIOSH-approved half-face or full-face air purifying respirators equipped with high-efficiency particulate air (HEPA) filters, eye protection meeting or exceeding ASSE/SAFE Z87.1 and hearing protectors (ear plugs and/or earmuffs) providing a noise reduction rating of at least 20 dBA or as needed to provide adequate protection.

2. Cleaning with Compressed Air
 - a. Cleaning with compressed air shall be in accordance with Section 20.B.5 of EM 385-1-1 and personnel shall be protected as specified in 29 CFR 1910.134.
3. Cleaning with Solvents
 - a. Ventilation
 - (1) Ventilation shall be provided where required by 29 CFR 1910.146 or where the concentration of solvent vapors exceeds 10 percent of the Lower Explosive Limit (LEL). Ventilation shall be in accordance with 29 CFR 1910.94, paragraph (c)(5).
 - b. Personal Protective Equipment
 - (1) Personal protective equipment shall be provided where required by 29 CFR 1910.146 and in accordance with 29 CFR 1910, Subpart I.
4. Mixing Epoxy and Polyurethane Resin Formulations
 - a. Exhaust Ventilation
 - (1) Local exhaust ventilation shall be provided in the area where the curing agent and resin are mixed. This ventilation system shall be capable of providing at least 100 linear fpm of capture velocity measured at the point where the curing agent and resin contact during mixing.
 - b. Personal Protective Equipment
 - (1) Exposure of skin and eyes to epoxy resin components shall be avoided by wearing appropriate chemically resistant gloves, apron, safety goggles, and face shields meeting or exceeding the requirements of ASSE/SAFE Z87.1.
 - c. Medical Precautions

- (1) Individuals who have a history of sensitivity to epoxy or polyurethane resin systems shall be medically evaluated before any exposure can occur. Individuals who are medically evaluated as exhibiting a sensitivity to epoxy resins shall not conduct work tasks or otherwise be exposed to such chemicals. Individuals who develop a sensitivity shall be immediately removed from further exposure and medically evaluated.

d. Emergency Equipment

- (1) A combination unit, comprised of an eyewash and deluge shower, within close proximity to the epoxy or polyurethane resin mixing operation shall be provided in accordance with ANSI Z358.1, paragraph (9).

5. Paint Application

a. Ventilation

- (1) When using solvent-based paint in confined spaces, ventilation shall be provided to exchange air in the space at a minimum rate of 5,000 cubic feet per minute per spray gun in operation. It may be necessary to install both a mechanical supply and exhaust ventilation system to effect adequate air changes within the confined space. All air-moving devices shall be located and affixed to an opening of the confined space in a manner that assures that the airflow is not restricted or short circuited and is supplied in the proper direction. Means of egress shall not be blocked. Ventilation shall be continued after completion of painting and through the drying phase of the operation. If the ventilation system fails or the concentration of volatiles exceeds 10 percent of the LEL (except in the zone immediately adjacent to the spray nozzle), painting shall be stopped, and spaces evacuated until such time that adequate ventilation is provided. An audible alarm that signals system failure shall be an integral part of the ventilation system. The effectiveness of the ventilation shall be checked by using ventilation smoke tubes and making frequent oxygen and combustible gas readings during painting operations. Exhaust ducts shall discharge clear of the working areas and away from possible sources of ignition.

b. Explosion Proof Equipment

- (1) Electrical wiring, lights, and other equipment located in the paint spraying area shall be of the explosion proof type designed for operation in Class I, Division 1, Group D, hazardous locations as

required by the NFPA 70. Electrical wiring, motors, and other equipment, outside of but within 20 feet of any spraying area, shall not spark and shall conform to the provisions for Class I, Division 2, Group D, hazardous locations. Electric motors used to drive exhaust fans shall not be placed inside spraying areas or ducts. Fan blades and portable air ducts shall be constructed of nonferrous materials. Motors and associated control equipment shall be properly maintained and grounded. The metallic parts of air-moving devices, spray guns, connecting tubing, and duct work shall be electrically bonded, and the bonded assembly shall be grounded.

c. Further Precautions

- (1) Workers shall wear non-sparking safety shoes.
- (2) Solvent drums taken into the spraying area shall be placed on nonferrous surfaces and shall be grounded. Metallic bonding shall be maintained between containers and drums when materials are being transferred.
- (3) Insulation on all power and lighting cables shall be inspected to ensure that the insulation is in excellent working condition and is free of all cracks and worn spots. Cables shall be further inspected to ensure that no connections are within 50 feet of the operation, that lines are not overloaded, and that they are suspended with sufficient slack to prevent undue stress or chafing.

d. Ignition Sources

- (1) Ignition sources, to include lighted cigarettes, cigars, pipes, matches, or cigarette lighters shall be prohibited in area of solvent cleaning, paint storage, paint mixing, or paint application.

6. Health Protection

a. Air Sampling

- (1) The Contractor shall perform air sampling and testing as needed to assure that workers are not exposed to contaminants above the permissible exposure limit. In addition, the Contractor shall provide the Construction Manager with a copy of the test results from the certified laboratory within five (5) working days of the sampling date and shall provide results from direct-reading instrumentation on the same day the samples are collected.

b. Respirators

- (1) During all spray-painting operations, spray painters shall use approved SCBA or SAR (air line) respirators, unless valid air sampling has demonstrated contaminant levels to be consistently within concentrations that are compatible with air-purifying respirator Assigned Protection Factor (APF). Persons with facial hair that interferes with the sealing surface of the facepiece to face seal or interferes with respirator valve function shall not be allowed to perform work requiring respiratory protection. Air-purifying chemical cartridge/canister half- or full-facepiece respirators that have a particulate prefilter and are suitable for the specific type(s) of gas/vapor and particulate contaminant(s) may be used for nonconfined space painting, mixing, and cleaning (using solvents). These respirators may be used provided the measured or anticipated concentration of the contaminant(s) in the breathing zone of the exposed worker does not exceed the APF for the respirator and the gas/vapor has good warning properties or the respirator assembly is equipped with a NIOSH-approved end of service life indicator for the gas(es)/vapor anticipated or encountered. Where paint contains toxic elements such as lead, cadmium, chromium, or other toxic particulates that may become airborne during painting in nonconfined spaces, air-purifying half- and full-facepiece respirators or powered air-purifying respirators equipped with appropriate gas vapor cartridges, in combination with a high-efficiency filter, or an appropriate canister incorporating a high-efficiency filter, shall be used.

c. Protective Clothing and Equipment

- (1) All workers shall wear safety shoes or boots, appropriate gloves to protect against the chemical to be encountered, and breathable, protective, full-body covering during spray-painting applications. Where necessary for emergencies, protective equipment such as lifelines, body harnesses, or other means of personnel removal shall be used during confined-space work.

1.09 MEDICAL STATUS

- A. Prior to the start of work and annually thereafter, all Contractor employees working with or around paint systems, thinners, blast media, those required to wear respiratory protective equipment, and those who will be exposed to high noise levels shall be medically evaluated for the particular type of exposure they may encounter. Medical records shall be maintained as required by 29 CFR 1910.20. The evaluation shall include:

1. Audiometric testing and evaluation of employees who will work in a noise environment with a time weighted average greater than or equal to 90 dBA.
2. Vision screening (employees who use full-facepiece respirators shall not wear contact lenses).
3. Medical evaluation shall include, but shall not be limited to, the following:
 - a. Medical history including, but not limited to, alcohol use, with emphasis on liver, kidney, and pulmonary systems, and sensitivity to chemicals to be used on the job.
 - b. General physical examination with emphasis on liver, kidney, and pulmonary system.
 - c. Determination of the employee's physical and psychological ability to wear respiratory protective equipment and to perform job-related tasks.
 - d. Determination of baseline values of biological indices for later comparison to changes associated with exposure to paint systems and thinners or blast media, which include: liver function tests to include SGOT, SGPT, GGPT, alkaline phosphates, bilirubin, complete urinalysis, EKG (employees over age 40), blood urea nitrogen (bun), serum creatinine, pulmonary function test, FVC, and FEV, chest x-ray (if medically indicated), blood lead and ZPP (for individuals where it is known there will be an exposure to materials containing lead), other criteria that may be deemed necessary by the Contractor's physician, and physician's statements for individual employees that medical status would permit specific task performance.

1.10 CHANGE IN MEDICAL STATUS

- A. Any employee whose medical status has changed negatively due to work-related chemical and/or physical agent exposure while working with or around paint systems and thinners, blast media, or other chemicals shall be evaluated by a physician, and the Contractor shall obtain a physician's statement as described in Paragraph 1.08 "MEDICAL STATUS" prior to allowing the employee to return to those work tasks. The Contractor shall notify the Construction Manager in writing of any negative changes in employee medical status and the results of the physician's reevaluation statement.

1.11 ENVIRONMENTAL PROTECTION

- A. In addition to the requirements of Section 015713, the Contractor shall comply with the following environmental protection criteria.
 1. Waste Classification, Handling and Disposal

- a. The Contractor shall be responsible for assuring the proper waste classification, handling and disposal of all hazardous and nonhazardous waste generated during the project. Nonhazardous waste shall be stored in closed containers separate from hazardous waste storage areas. All nonhazardous waste shall be transported in accordance with local regulations regarding waste transportation.
2. Air Quality Monitoring
 - a. PM-10 Monitoring
 - (1) The Contractor shall perform PM-10 monitoring. The positioning of air monitoring equipment shall be in accordance with 40 CFR 58, App E, Subpart (8). In addition, a minimum of two (2) PM-10 monitors shall be used at the project site, one (1) downwind from the project and one (1) in the area of greatest public access (e.g., playground, school yard, or homeowner's yard). When the project is in an area where there are critical receptors nearby, monitoring shall be conducted throughout the entire period that abrasive blasting and cleanup operations are performed. Otherwise, monitoring shall be performed four (4) of the first eight (8) days and on a regular basis thereafter for a sum total of 25 percent of the time surface preparation and debris cleanup are performed. Failure to meet air quality regulatory limits shall require air monitoring to be repeated immediately after corrective actions have been taken. The Contractor shall also conduct pre-project PM-10 monitoring. The pre-project PM-10 monitoring shall be conducted a minimum of two (2) weeks prior to the beginning of the project. The monitoring shall continue for a minimum of three (3) days to establish background levels. A report of the results shall be submitted to the Construction Manager within 48 hours and shall include:
 - a. Name and location of jobsite.
 - b. Date of monitoring.
 - c. Time of monitoring (i.e., time monitoring begins and ends each day).
 - d. Identification and serial number of monitoring units.
 - e. Drawing showing specific location of monitoring units.
 - f. Drawing showing specific location of paint removal operation and the method of removal or work activity being performed.

- g. Wind direction and velocity.
- h. A flow chart verifying the rate of air flow across the filter throughout the sampling period.
- i. Name and address of laboratory.
- j. Laboratory test procedure.
- k. Laboratory test results.
- l. Signatures of field and laboratory technicians conducting the work.

1.12 PAINT PACKAGING, DELIVERY, AND STORAGE

- A. Paints shall be processed and packaged to ensure that within a period of one (1) year from date of manufacture, they will not gel, liver, or thicken deleteriously, or form gas in the closed container. Paints, unless otherwise specified or permitted, shall be packaged in standard containers not larger than five (5) gallons, with removable friction or lug-type covers. Each container of paint or separately packaged component thereof shall be labeled to indicate the purchaser's order number, date of manufacture, manufacturer's batch number, quantity, color, component identification and designated name, and formula or specification number of the paint together with special labeling instructions, when specified. Paint shall be delivered to the job in unbroken containers. Paints that can be harmed by exposure to cold weather shall be stored in ventilated, heated shelters. All paints shall be stored under cover from the elements and in locations free from sparks and flames.

PART 2 - PRODUCTS

2.01 SPECIAL PAINT FORMULAS

- A. Special paints shall have the composition as indicated in the formulas listed herein. Where so specified, certain components of a paint formulation shall be packaged in separate containers for mixing on the job. If not specified or otherwise prescribed, the color shall be that naturally obtained from the required pigmentation.

2.02 PAINT FORMULATIONS

- A. Special paint formulas shall comply with the following:
 - 1. Formula C-200a, Coal Tar-Epoxy (Black) Paint

- a. The paint shall conform to SSPC Paint 16 manufactured with Type 1 pitch. In addition to standard labeling, container labels shall include the term, Corps of Engineers Formula C-200a.
2. Solvent and Thinners
 - a. Xylene shall conform to ASTM D843.

PART 3 - EXECUTION

3.01 CLEANING AND PREPARATION OF SURFACES TO BE PAINTED

A. General Requirements

1. Surfaces to be painted shall be cleaned before applying paint or surface treatments. Deposits of grease or oil shall be removed in accordance with SSPC SP 1, prior to mechanical cleaning. Solvent cleaning shall be accomplished with mineral spirits or other low toxicity solvents having a flash point above 100 degrees F. Clean cloths and clean fluids shall be used to avoid leaving a thin film of greasy residue on the surfaces being cleaned. Items not to be prepared or coated shall be protected from damage by the surface preparation methods. Machinery shall be protected against entry of blast abrasive and dust into working parts. Cleaning and painting shall be so programmed that dust or other contaminants from the cleaning process do not fall on wet, newly painted surfaces, and surfaces not intended to be painted shall be suitably protected from the effects of cleaning and painting operations. Welding of, or in the vicinity of, previously painted surfaces shall be conducted in a manner to prevent weld spatter from striking the paint and to otherwise reduce coating damage to a minimum; paint damaged by welding operations shall be restored to original condition. Surfaces to be painted that will be inaccessible after construction, erection, or installation operations are completed shall be painted before they become inaccessible.

3.02 PAINT APPLICATION

A. General

1. The finished coating shall be free from holidays, pinholes, bubbles, runs, drops, ridges, waves, laps, excessive or unsightly brush marks, and variations in color, texture, and gloss. Application of initial or subsequent coatings shall not commence until the Construction Manager has verified that atmospheric conditions and the surfaces to be coated are satisfactory. Each paint coat shall be applied in a manner that will produce an even, continuous film of uniform thickness. Edges, corners, crevices, seams, joints, welds, rivets, corrosion pits, and other surface irregularities shall receive special attention to ensure that they receive an adequate thickness of paint. Spray equipment shall be equipped with traps and separators

and where appropriate, mechanical agitators, pressure gauges, pressure regulators, and screens or filters. Air caps, nozzles, and needles shall be as recommended by the spray equipment manufacturer for the material being applied. Airless-type spray equipment may be used only on broad, flat, or otherwise simply configured surfaces, except that it may be employed for general painting if the spray gun is equipped with dual or adjustable tips of proper types and orifice sizes. Airless-type equipment shall not be used for the application of vinyl paints.

2. Mixing and Thinning

- a. Paints shall be thoroughly mixed, strained where necessary, and kept at a uniform composition and consistency during application. Paste or dry-powder pigments specified to be added at the time of use shall, with the aid of powered stirrers, be incorporated into the vehicle or base paint in a manner that will produce a smooth, homogeneous mixture free of lumps and dry particles. Where necessary to suit conditions of the surface temperature, weather, and method of application, the paint may be thinned immediately prior to use. Thinning shall generally be limited to the addition of not more than 1 pint per gallon of the proper thinner; this general limitation shall not apply when more specific thinning instructions are provided. Paint that has been stored at low temperature, shall be brought up to at least 70 degrees F before being mixed and thinned, and its temperature in the spray tank or other working container shall not fall below 60 degrees F during the application. Paint that has deteriorated in any manner to a degree that it cannot be restored to essentially its original condition by customary field-mixing methods shall not be used and shall be removed from the project site. Paint and thinner that is more than one (1) year old shall be resampled and resubmitted for testing to determine its suitability for application.

3. Atmospheric and Surface Conditions

- a. Paint shall be applied only to surfaces that are above the dew point temperature and that are completely free of moisture as determined by sight and touch. Paint shall not be applied to surfaces upon which there is detectable frost or ice. Except as otherwise specified, the temperature of the surfaces to be painted and of air in contact therewith shall be not less than 45 degrees F during paint application nor shall paint be applied if the surfaces can be expected to drop to 32 degrees F or lower before the film has dried to a reasonably firm condition. During periods of inclement weather, painting may be continued by enclosing the surfaces and applying artificial heat, provided the minimum temperatures and surface dryness requirements prescribed previously are maintained. Paint shall not be applied to surfaces heated by direct sunlight or other sources to temperatures that will cause detrimental blistering, pinholing, or porosity of the film.

4. Time Between Surface Preparation and Painting
 - a. Surfaces that have been cleaned and/or otherwise prepared for painting shall be primed as soon as practicable after such preparation has been completed but, in any event, prior to any deterioration of the prepared surface.
5. Method of Paint Application
 - a. Unless otherwise specified, paint shall be applied by brush or spray to ferrous and nonferrous metal surfaces. Special attention shall be directed toward ensuring adequate coverage of edges, corners, crevices, pits, rivets, bolts, welds, and similar surface irregularities. Other methods of application to metal surfaces shall be subject to the specific approval of the Construction Manager. Paint on plaster, concrete, or other nonmetallic surfaces shall be applied by brush, roller, and/or spray.
6. Coverage and Film Thickness
 - a. Film thickness or spreading rates shall be as specified hereinafter. Where no spreading rate is specified, the paint shall be applied at a rate normal for the type of material being used. In any event, the combined coats of a specified paint system shall completely hide base surface and the finish coats shall completely hide undercoats of dissimilar color.
 - b. Measurement on Ferrous Metal
 - (1) Where dry film thickness requirements are specified for coatings on ferrous surfaces, measurements shall be made with a gage qualified in accordance with Paragraph 1.05.2 "Coating Thickness Gage Qualification". They shall be calibrated and used in accordance with ASTM D7091. They shall be calibrated using plastic shims with metal practically identical in composition and surface preparation to that being coated, and of substantially the same thickness (except that for measurements on metal thicker than 1/4 inch, the instrument may be calibrated on metal with a minimum thickness of 1/4 inch). Frequency of measurements shall be as recommended for field measurements by ASTM D7091 and reported as the mean for each spot determination. The instruments shall be calibrated or have the instrument's calibration verified prior to, during, and after each use.
7. Progress of Painting Work
 - a. Where field painting on any type of surface has commenced, the complete painting operation, including priming and finishing coats, on that portion of the work shall be completed as soon as practicable, without prolonged delays. Sufficient time shall elapse between successive coats to permit them to dry

properly for recoating, and this period shall be modified as necessary to suit adverse weather conditions. Paint shall be considered dry for recoating when it feels firm, does not deform or feel sticky under moderate pressure of the finger, and the application of another coat of paint does not cause film irregularities such as lifting or loss of adhesion of the undercoat. All coats of all painted surfaces shall be unscarred and completely integral at the time of application of succeeding coats. At the time of application of each successive coat, undercoats shall be cleaned of dust, grease, overspray, or foreign matter by means of airblast, solvent cleaning, or other suitable means. Cement and mortar deposits on painted steel surfaces, not satisfactorily removed by ordinary cleaning methods, shall be brush-off blast cleaned and completely repainted as required. Undercoats of high gloss shall, if necessary for establishment of good adhesion, be scuff sanded, solvent wiped, or otherwise treated prior to application of a succeeding coat. Field coats on metal shall be applied after erection except as otherwise specified and except for surfaces to be painted that will become inaccessible after erection.

8. Contacting Surfaces

- a. When riveted or ordinary bolted contact is to exist between surfaces of ferrous or other metal parts of substantially similar chemical composition, such surfaces will not be required to be painted, but any resulting crevices shall subsequently be filled or sealed with paint. Contacting metal surfaces formed by high-strength bolts in friction-type connections shall not be painted. Where a nonmetal surface is to be in riveted or bolted contact with a metal surface, the contacting surfaces of the metal shall be cleaned and given three coats of the specified primer. Unless otherwise specified, corrosion-resisting metal surfaces, including cladding therewith, shall not be painted.

9. Drying Time Prior to Immersion

- a. Minimum drying periods after final coat prior to immersion shall be: epoxy systems at least five (5) days, vinyl-type paint systems at least three (3) days, and cold-applied coal tar systems at least seven (7) days. Minimum drying periods shall be increased twofold if the drying temperature is below 65 degrees F and/or if the immersion exposure involves considerable abrasion.

10. Protection of Painted Surfaces

- a. Where shelter and/or heat are provided for painted surfaces during inclement weather, such protective measures shall be maintained until the paint film has dried and discontinuance of the measures is authorized. Items that have been painted shall not be handled, worked on, or otherwise disturbed until the paint coat is fully dry and hard. All metalwork coated in the shop or field prior to

final erection shall be stored out of contact with the ground in a manner and location that will minimize the formation of water-holding pockets; soiling, contamination, and deterioration of the paint film, and damaged areas of paint on such metalwork shall be cleaned and touched up without delay. The first field coat of paint shall be applied within a reasonable period of time after the shop coat and in any event before weathering of the shop coat becomes extensive.

11. Coal Tar-Epoxy (Black) Paint (Formula C-200a)

a. Mixing

- (1) Component B shall be added to previously stirred Component A and thoroughly mixed together with a heavy-duty mechanical stirrer just prior to use. The use of not more than 1 pint of xylene thinner per 1 gallon of paint will be permitted to improve application properties and extend pot life. The pot life of the mixed paint, extended by permissible thinning, may vary from two (2) hours in very warm weather to five (5) or more hours in cool weather. Pot life in warm weather may be extended by precooling the components prior to mixing; cooling the mixed material; and/or by slow, continuous stirring during the application period. The mixed material shall be applied before unreasonable increases in viscosity take place.

b. Application

- (1) Spray guns shall be of the conventional type equipped with a fluid tip of approximately 0.09 inch in diameter and external atomization, seven-hole air cap. Material shall be supplied to the spray gun from a bottom withdrawal pot or by means of a fluid pump; hose shall be 1/2 inch in diameter. Atomization air pressure shall not be less than 80 psi. High-pressure airless spray equipment may be used only on broad, simply configured surfaces. Brush application shall be with a stiff-bristled tool heavily laden with material and wielded in a manner to spread the coating smoothly and quickly without excessive brushing. The coverage rate of the material is approximately 110 square feet/gallon per coat to obtain 20 mils (dry thickness) in a two-coat system. The paint shall flow together and provide a coherent, pinhole-free film. The direction of the spray passes (or finish strokes if brushed) of the second coat shall be at right angles to those of the first where practicable.

c. Subsequent Coats

- (1) Except at the high temperatures discussed later in this paragraph, the drying time between coal tar-epoxy coats shall not be more than 72 hours, and application of a subsequent coat as soon as the undercoat is reasonably firm is strongly encouraged. Where the temperature for substrate or coating surfaces during application or curing exceeds or can be expected to exceed 125 degrees F as the result of direct exposure to sunlight, the surfaces shall be shaded by overhead cover or the interval between coats shall be reduced as may be found necessary to avoid poor intercoat adhesion. Here, poor intercoat adhesion is defined as the inability of two or more dried coats of coal tar-epoxy paint to resist delamination when tested aggressively with a sharp knife. Under the most extreme conditions involving high ambient temperatures and sun-exposed surfaces, the drying time between coats shall not exceed 10 hours, and the reduction of this interval to a few hours or less is strongly encouraged. Where the curing time of a coal tar-epoxy undercoat exceeds 72 hours of curing at normal temperatures, 10 hours at extreme conditions, or where the undercoat develops a heavy blush, it shall be given one of the following treatments before the subsequent coat is applied:

- a. Etch the coating surface lightly by brush-off blasting, using fine sand, low air pressure, and a nozzle-to-surface distance of approximately 3 feet.
- b. Remove the blush and/or soften the surface of the coating by wiping it with cloths dampened with 1-methyl-2-pyrrolidone. The solvents may be applied to the surface by fog spraying followed by wiping, but any puddles of solvent must be mopped up immediately after they form. The subsequent coat shall be applied in not less than 15 minutes or more than three (3) hours after the solvent treatment.

d. Ambient Temperature

- (1) Coal tar-epoxy paint shall not be applied when the receiving surface or the ambient air is below 50 degrees F nor unless it can be reasonably anticipated that the average ambient temperature will be 50 degrees F or higher for the five (5) day period subsequent to the application of any coat.

e. Safety

- (1) In addition to the safety provisions in Paragraph 1.07 "SAFETY AND HEALTH PROVISIONS", other workmen as well as painters

shall avoid inhaling atomized particles of coal tar-epoxy paint and contact of the paint with the skin.

3.03 PAINT SYSTEMS APPLICATION

A. The required paint systems and the surfaces to which they shall be applied are shown in this paragraph, and/or in the drawings. Supplementary information follows.

1. Fabricated and Assembled Items - Items that have been fabricated and/or assembled into essentially their final form and that are customarily cleaned and painted in accordance with the manufacturer's standard practice will be exempted from equivalent surface preparation and painting requirements described herein, provided that:

- a. Surfaces primed (only) in accordance with such standard practices are compatible with specified field-applied finish coats.
- b. Surfaces that have been primed and finish painted in accordance with the manufacturer's standard practice are of acceptable color and are capable of being satisfactorily touched up in the field.
- c. Items expressly designated herein to be cleaned and painted in a specified manner are not coated in accordance with the manufacturer's standard practice if different from that specified herein.

2. Surface Preparation

- a. The method of surface preparation and pretreatment shown in the tabulation of paint systems is for identification purposes only. Cleaning and pretreatment of surfaces prior to painting shall be accomplished in accordance with detailed requirements previously described.

3. System No. 6

- a. Paint shall be spray or brush applied with a minimum of two coats to provide a minimum total thickness at any point of 16 mils. The specified film thickness shall be attained in any event, and any additional (beyond two) coats needed to attain specified thickness shall be applied at no additional cost to the DEP.

4. Protection of Nonpainted Items and Cleanup

- a. Walls, equipment, fixtures and all other items in the vicinity of the surfaces being painted shall be maintained free from damage by paint or painting activities. Paint spillage and painting activity damage shall be promptly repaired.

3.04 INSPECTION

- A. The Contractor shall inspect, document, and report all work phases and operations on a daily basis. As a minimum the daily report shall contain the following:
1. Inspections performed, including the area of the structure involved and the results of the inspection.
 2. Surface preparation operations performed, including the area of the structure involved, the mode of preparation, the kinds of solvent, abrasive, or power tools employed, and whether contract requirements were met.
 3. Thinning operations performed, including thinners used, batch numbers, and thinner/paint volume ratios.
 4. Application operations performed, including the area of the structure involved, mode of application employed, ambient temperature, substrate temperature, dew point, relative humidity, type of paint with batch numbers, elapsed time between surface preparation and application, elapsed time for recoat, condition of underlying coat, number of coats applied, and if specified, measured dry film thickness or spreading rate of each new coating.

3.05 PAINTING SCHEDULES

- A. The top ten (10') feet of all sheet piles, HP piles, and micro piles shall be coated with coal tar epoxy.

SYSTEM NO. 6

Items or surfaces to be coated: Sheet Piles, HP Piles, and Micro Piles

<u>SURFACE PREPARATION</u>	<u>1st COAT</u>	<u>2nd COAT</u>	<u>3rd COAT</u>
White metal blast cleaning	Coal tar-epoxy C-200a (black)	Coal tar-epoxy C-200a (black)	Coal tar-epoxy C-200a (black) (If needed to attain required thickness)

3.06 CONTRACT CLOSEOUT

- A. Provide in accordance with Section 017700.

END OF SECTION 099702

SECTION 101400 - SIGNAGE

PART 1 - GENERAL

1.01 DESCRIPTION

A. Provide signage as indicated and in compliance with Contract Documents.

1. Section Includes:

- a. Illuminated panel signs.
- b. Panel signs

1.02 PAYMENT

A. No separate payment shall be made for performing any Work required under this Section. All costs for Work required by this Section shall be included in the applicable lump sum for Urban Amenities, as set forth in Section 012901.

1.03 REFERENCES

A. American Architectural Manufacturers Association (AAMA):

1. 611: Voluntary Specification for Anodized Architectural Aluminum
2. 2603: Voluntary Specification, Performance Requirements and Test Procedures for Pigmented Organic Coatings on Aluminum Extrusions and Panels

B. American National Standards Institute (ANSI):

1. A117.1: Accessible and Usable Buildings and Facilities.

C. ASTM International (ASTM):

1. A572: Specification for Steel Plate.
2. A653/A653M: Standard Specification for Steel Sheet, Zinc-Coated (Galvanized) or Zinc-Iron Alloy-Coated (Galvannealed) by the Hot-Dip Process.
3. A780: Standard Practice for Repair of Damaged and Uncoated Areas of Hot-Dip Galvanized Coatings.
4. A879/A879M: Standard Specification for Steel Sheet, Zinc Coated by the Electrolytic Process for Applications Requiring Designation of the Coating Mass on Each Surface.

5. A1008/A1008M: Standard Specification for Steel, Sheet, Cold-Rolled, Carbon, Structural, High-Strength Low-Alloy, High-Strength Low-Alloy with Improved Formability, Solution Hardened, and Bake Hardenable.

D. Federal Regulations:

1. 40 CFR 59, Subpart D: National Volatile Organic Compound Emission Standards for Architectural Coatings

E. National Electrical Manufacturers Association (NEMA):

1. LD3: High-Pressure Decorative Laminates.

F. The Society for Protective Coatings (SSPC):

1. Paint 20: Zinc-Rich Coating Type I Inorganic and Type II Organic

1.04 RELATED SECTIONS

A. General Conditions Article 4.7 – Shop Drawings and Other Submittals

B. Section 012901 – Measurement and Payment

C. Section 014300 - Quality Requirements

D. Section 016100 – Control of Materials

E. Section 017700 – Contract Closeout

F. Section 265619 – LED Lighting

1.05 DEFINITIONS

A. Accessible: In accordance with the accessibility standard.

B. Illuminated: Illuminated by lighting source integrally constructed as part of the sign unit.

1.06 COORDINATION

A. Coordinate placement of sign-anchorage devices to be embedded in permanent construction.

B. Coordinate placement of electrical conduits, junction boxes and other devices to be embedded in permanent construction.

1.07 SUBMITTALS

- A. Submit the following shop drawings in accordance with General Conditions Article 4.7.
- B. Product Data: For each type of product.
- C. Shop Drawings: For panel signs.
 - 1. Include fabrication and installation details and attachments to other work.
 - 2. Show sign mounting heights, locations of supplementary supports to be provided by others, and accessories.
 - 3. Show locations of electrical service connections.
 - 4. Include diagrams for power, signal, and control wiring.
- D. Samples for Initial Selection: For each type of sign assembly, exposed component, and exposed finish.
 - 1. Include representative Samples of available typestyles and graphic symbols.
- E. Samples for Verification: For each type of sign assembly showing all components and with the required finish(es), in manufacturer's standard size unless otherwise indicated and as follows:
 - 1. Panel Signs: Full-size Sample
- F. Sign Schedule: Use same designations specified or indicated on Contract Drawings or in a sign schedule.
- G. Delegated-Design Submittal: For signs indicated in "Performance Requirements" paragraph 1.08 of this section.
 - 1. Include structural analysis calculations for signs indicated to comply with design loads; signed and sealed by the qualified professional engineer responsible for their preparation.
- H. Qualification Data: For Installer.
- I. Sample Warranty: For special warranty.
- J. Maintenance Data: For signs to include in maintenance manuals.

1.08 QUALITY ASSURANCE

- A. Comply with the requirements specified in Section 014300.

1.09 REGULATORY REQUIREMENTS

- A. Conform to building code for requirements for the physically handicapped.
- B. Conform to ADAAG and UFAS.

1.10 DELIVERY STORAGE AND HANDLING

- A. Comply with the requirements specified in Section 016100.
- B. Package signs, labeled in name groups.

1.11 PROJECT/SITE CONDITIONS

- A. Field Measurements: Verify locations of anchorage device and electrical service embedded in permanent construction by field measurements before fabrication and indicate measurements on Shop Drawings.
- B. Do not install signs when ambient temperature is below 70 degrees F.
- C. Maintain this minimum during and after installation of signs.

1.12 WARRANTY

- A. Special Warranty: Manufacturer agrees to repair or replace components of signs that fail in materials or workmanship within the one-year warranty period described in general conditions article 8.
 - 1. Failures include, but are not limited to, the following:
 - a. Deterioration of finishes beyond normal weathering.
 - b. Separation or delamination of sheet materials and components.

PART 2 - PRODUCTS

2.01 PANEL SIGNS, GENERAL

- A. Thermal Movements: For exterior signs, allow for thermal movements from ambient and surface temperature changes.
 - 1. Temperature Change: 120 degrees F, ambient; material surfaces.

2.02 SIGNS

- A. Manufacturers:

1. Custom Fabricated on the Contract Drawings.
- B. Panel Sign: Sign with smooth, uniform surfaces; with message and characters having uniform faces, sharp corners, and precisely formed lines and profiles; and as follows:
1. Illuminated Panel Sign: Backlighted construction with LED lighting including transformers, insulators, and other accessories for operability, with provision for servicing and concealing connections to building electrical system. Use tight or sealed joint construction to prevent unintentional light leakage.
 - a. LED Flexible Strip Lighting: As per Section 265619.
 - b. Power: 12VDC Power Supply White (6500 K)
 - c. Weeps: Provide weep holes to drain water at lowest part of exterior signs. Equip weeps with permanent baffles to block light leakage without inhibiting drainage.
 2. Solid-Sheet Sign and Returns, Returns, and Back: Steel:
 - a. Thickness: As indicated on the Contract Drawings
 3. Sign-Panel Perimeter: Finish edges smooth.
 - a. Edge Condition, Vertical Edges, Horizontal Edges: As indicated
 - b. Corner Condition in Elevation: As indicated
 4. Frame: Entire perimeter
 - a. Material: Steel
 - b. Material Thickness: As indicated on the Contract Drawings
 - c. Frame Depth: As indicated on the Contract Drawings
 - d. Finish and Color: High-Performance Super Durable Powder Finish: Two-coat powder coating system, including zinc rich powder primer followed by a Super Durable powder complying with AAMA 2604 and containing 100 percent Super Durable Polyester resin. Prepare, pretreat, and apply coating to exposed metal surfaces to comply with coating and resin manufacturers' written instructions. Color as indicated in the Contract Drawings.
 5. Mounting: As indicated on the Contract Drawings
 6. Surface Finish:

- a. Powder-Coat Finish: High-Performance Super Durable Powder Finish: Two-coat powder coating system, including zinc rich powder primer followed by a Super Durable powder complying with AAMA 2604 and containing 100 percent Super Durable Polyester resin. Prepare, pretreat, and apply coating to exposed metal surfaces to comply with coating and resin manufacturers' written instructions.
7. Text and Typeface: Laser cut as indicated on the Contract Drawings.
8. Flatness Tolerance: Sign panel shall remain flat or uniformly curved under installed conditions as indicated and within a tolerance of +/-1/16 inch measured diagonally from corner to corner.

2.03 PANEL-SIGN MATERIALS

A. Steel Materials:

1. Steel Sheet: High-Performance Super Durable Powder Finish: Two-coat powder coating system, including zinc rich powder primer followed by a Super Durable powder complying with AAMA 2604 and containing 100 percent Super Durable Polyester resin. Prepare, pretreat, and apply coating to exposed metal surfaces to comply with coating and resin manufacturers' written instructions.
2. Steel Members Fabricated from Plate or Bar Stock: ASTM A529/A529M or ASTM A572/A572M, 42,000 psi minimum yield strength.
3. For steel exposed to view on completion, provide materials having flat, smooth surfaces without blemishes. Do not use materials whose surfaces exhibit pitting, seam marks, roller marks, rolled trade names, or roughness.

- B. Paints and Coatings for Sheet Materials: Inks, dyes, and paints that are recommended by manufacturer for optimum adherence to surface and are UV and water resistant for colors and exposure indicated.

2.04 DIMENSIONAL LETTERS AND NUMBERS

A. Manufacturers:

1. Custom Fabricated: As indicated on the Contract Drawings.

2.05 ACCESSORIES

- A. Fasteners and Anchors: Manufacturer's standard as required for secure anchorage of signage, noncorrosive and compatible with each material joined, and complying with the following:

1. Use concealed fasteners and anchors unless indicated to be exposed.
2. For exterior exposure, furnish hot-dip galvanized devices unless otherwise indicated.
3. Exposed Metal-Fastener Components, General:
 - a. Fabricated from same basic metal and finish of fastened metal unless otherwise indicated.
 - b. Fastener Heads: For nonstructural connections, use Allen-head slots unless otherwise indicated.
4. Sign Mounting Fasteners:
 - a. Concealed Studs: Concealed (blind), threaded studs welded or brazed to back of sign material or screwed into back of sign assembly, unless otherwise indicated.
 - b. Projecting Studs: Threaded studs with sleeve spacer, welded or brazed to back of sign material or screwed into back of sign assembly, unless otherwise indicated.
 - c. Through Fasteners: Exposed metal fasteners matching sign finish, with type of head indicated, installed in predrilled holes.

2.06 FABRICATION

- A. General: Provide manufacturer's standard sign assemblies according to requirements indicated.
 1. Preassemble signs and assemblies in the shop to greatest extent possible. Disassemble signs and assemblies only as necessary for shipping and handling limitations. Clearly mark units for reassembly and installation; apply markings in locations concealed from view after final assembly.
 2. Mill joints to a tight, hairline fit. Form assemblies and joints exposed to weather to resist water penetration and retention.
 3. Comply with AWS for recommended practices in welding and brazing. Provide welds and brazes behind finished surfaces without distorting or discoloring exposed side. Clean exposed welded and brazed connections of flux, and dress exposed and contact surfaces.
 4. Conceal connections if possible; otherwise, locate connections where they are inconspicuous.

5. Internally brace signs for stability and for securing fasteners.
6. Provide rebates, lugs, and brackets necessary to assemble components and to attach to existing work. Drill and tap for required fasteners. Use concealed fasteners where possible; use exposed fasteners that match sign finish.

2.07 GENERAL FINISH REQUIREMENTS

- A. Protect mechanical finishes on exposed surfaces from damage by applying a strippable, temporary protective covering before shipping.
- B. Appearance of Finished Work: Noticeable variations in same piece are not acceptable. Variations in appearance of adjoining components are acceptable if they are within the range of accepted Samples and are assembled or installed to minimize contrast.
- C. Directional Finishes: Run grain with long dimension of each piece and perpendicular to long dimension of finished trim or border surface unless otherwise indicated.
- D. Organic, Anodic, and Chemically Produced Finishes: Apply to formed metal after fabrication but before applying contrasting polished finishes on raised features unless otherwise indicated.

2.08 STEEL FINISHES

- A. Surface Preparation: Remove mill scale and rust, if present, from uncoated steel, and prepare for coating according to coating manufacturer's written instructions.
 1. Powder-Coat Finish: After cleaning, apply a conversion coating compatible with the organic coating to be applied over it.
- B. Factory Prime Finish: After surface preparation and pretreatment, apply manufacturer's standard, fast-curing, lead- and chromate-free, universal primer.
- C. Powder-Coat Finish: After cleaning and pretreating, apply manufacturer's standard two-coat, baked-on finish consisting of prime coat and thermosetting topcoat to a minimum dry film thickness of 2 mils (0.05 mm).

PART 3 - EXECUTION

3.01 EXAMINATION

- A. Examine substrates, areas, and conditions, with Installer present, for compliance with requirements for installation tolerances and other conditions affecting performance of signage work.

- B. Verify that sign-support surfaces are within tolerances to accommodate signs without gaps or irregularities between backs of signs and support surfaces unless otherwise indicated.
- C. Verify that anchor inserts are correctly sized and located to accommodate signs.
- D. Proceed with installation only after unsatisfactory conditions have been corrected.

3.02 INSTALLATION

- A. General: Install signs using mounting methods indicated and according to architectural drawings.
 - 1. Notify Construction Manager in writing of sign installation at least twenty-one (21) days in advance. Confirm with the Construction Manager, the exact location for each sign.
 - 2. Install signs level, plumb, true to line, and at locations and heights indicated, with sign surfaces free of distortion and other defects in appearance.
 - 3. Install signs so they do not protrude or obstruct according to the accessibility standard.
 - 4. Before installation, verify that sign surfaces are clean and free of materials or debris that would impair installation.
 - 5. Corrosion Protection: Coat concealed surfaces of exterior aluminum in contact with grout, concrete, masonry, wood, or dissimilar metals, with a heavy coat of bituminous paint.

3.03 ADJUSTING AND CLEANING

- A. Remove and replace damaged or deformed signs and signs that do not comply with specified requirements. Replace signs with damaged or deteriorated finishes or components that cannot be successfully repaired by finish touchup or similar minor repair procedures.
- B. Remove temporary protective coverings and strippable films as signs are installed.
- C. On completion of installation, clean exposed surfaces of signs according to manufacturer's written instructions and touch up minor nicks and abrasions in finish. Maintain signs in a clean condition during construction and protect from damage until acceptance by Construction Manager.

3.04 CONTRACT CLOSEOUT

- A. Provide in accordance with Section 017700.

3.05 SCHEDULES

- A. See Schedule as indicated in the Contract Drawings.

END OF SECTION 101400

SECTION 116800 - PLAY FIELD EQUIPMENT AND STRUCTURES

PART 1 - GENERAL

1.01 DESCRIPTION

- A. Provide play field equipment and structures as indicated and in compliance with Contract Documents.
 - 1. Freestanding playground equipment

1.02 PAYMENT

- A. No separate payment shall be made for performing any Work required under this Section. All costs for Work required by this Section shall be included in the applicable lump sum(s), unit price(s), or allowance(s) as set forth in Section 012901.

1.03 RELATED SECTIONS

- A. General Conditions Article 4.7 – Shop Drawings and Other Submittals
- B. Section 012901 – Measurement and Payment
- C. Section 017700 – Contract Closeout
- D. Section 033000 - Cast-In-Place Concrete
- E. Section 321816 - Playground Protective Surfacing

1.04 DEFINITIONS

- A. IPEMA: International Play Equipment Manufacturers Association.
- B. Use Zone: According to ASTM F 1487, the "area beneath and immediately adjacent to a play structure or equipment that is designated for unrestricted circulation around the equipment and on whose surface it is predicted that a user would land when falling from or exiting the equipment."

1.05 SUBMITTALS

- A. Submit the following items in accordance with General Conditions Article 4.7.
- B. Product Data: For each type of product indicated. Submit complete lists of items proposed under this Section to Landscape Architect. Include manufacturer's name and address, specific trade names; catalog numbers complete with installation instructions, illustrations, and descriptive literature.
- C. Shop Drawings: For playground or outdoor fitness equipment and structures. Include plans, elevations, sections, details, and attachments to other work.
- D. Samples for Initial Selection: For each type of playground equipment and structure indicated.
 - 1. Manufacturer's color charts.
- E. Samples for Verification: For each type of exposed finish required, prepared on Samples of size indicated below.
 - 1. Posts and Rails: Not less than 3 inches long.
 - 2. Molded Plastic: Not less than 3 inches square.
 - 3. Rope and Mounting Hardware: Not less than 3 inches long.
- F. Coordination Drawings: Plans, drawn to scale, on which the following items are shown and coordinated with each other, using input from installers of the items involved.
 - 1. Extent of surface systems and use zones for equipment.
 - 2. Critical heights for playground surfaces and fall heights for equipment.
- G. Qualification Data: For qualified installer.
- H. Product Certificates: For each type of playground equipment, from manufacturer.
- I. Material Certificates: For the following items, signed by manufacturers:
 - 1. Shop finishes.
- J. Product Test Reports: Based on evaluation of comprehensive tests performed by a qualified testing agency, for each type of playground or outdoor fitness equipment.

K. Field quality-control reports.

L. Warranty: Sample of special warranty.

1.06 CLOSEOUT SUBMITTALS

A. Maintenance Data: For playground and outdoor fitness equipment and finishes to include in maintenance manuals.

1.07 QUALITY ASSURANCE

A. Conform to the requirements in Section 014300.

B. Manufacturer Qualifications: A firm whose playground equipment components have been certified by IPEMA's third-party product certification service.

1. Provide IPEMA Certification Seal for all items listed under 2.03

C. Installer Qualifications: Installers and supervisors who are trained and approved by manufacturer.

D. Safety Standards: Provide playground equipment complying with or exceeding requirements in ASTM F 1487.

E. Safety Standards: Provide outdoor fitness equipment complying with or exceeding requirements in ASTM F3101-15 Standard Specification For Unsupervised Outdoor Fitness Equipment.

F. All installed equipment and protective surfacing required to meet applicable safety and other inspection criteria. For playground surfacing, comply with requirements in Section 321816 – Playground Protective Surfacing. Contractor to confirm certification of playground construction by a certified playground equipment inspector upon completion of playground and protective surfacing installation.

1.08 WARRANTY

A. Special Warranty: Manufacturer's standard form in which manufacturer agrees to repair or replace components of playground equipment that fail in materials or workmanship within specified warranty period.

1. Failures include, but are not limited to, the following:

- a. Structural failures.
 - b. Deterioration of metals, metal finishes, and other materials beyond normal weathering.
 - c. Found defective upon delivery
2. Warranty Period: A minimum of two years from date of Substantial Completion for all components and finishes.

PART 2 - PRODUCTS

2.01 PLAYGROUND EQUIPMENT FABRICATION

- A. General: Verify and comply with manufacturer's fabrication, fall height and fall zone requirements. Provide sizes, strengths, thicknesses, wall thickness, and weights of components as indicated but not less than required to comply with structural performance and other requirements in ASTM F1487 or F3101. Factory drill components for field assembly. Unnecessary holes in components, not required for field assembly, are not permitted. Provide complete play structure, including supporting members and connections, handholds, and other components indicated or required to comply with referenced standards for equipment indicated.
- B. Metal Frame: Fabricate main-frame upright support posts from metal pipe or tubing with cross-section profile and dimensions as indicated. Unless otherwise indicated, provide each pipe or tubing main-frame member with manufacturer's standard drainable bottom plate or support flange. Fabricate secondary frame members, bracing, and connections from either steel or aluminum.

2.02 MANUFACTURERS/SUPPLIERS

- A. APE Studio Inc. / Richter Spielgerate GmbH, 246 5th Ave, Suite 620, New York, NY 10001; Telephone: 212-213-6636; Email: info@apeoriginal.com; Web: www.apeoriginal.com
- B. Berliner-Seilfabrik Play Equipment Corporation, Brookfield South Business Center, 96 Brookfield Oaks Drive, Suite 140, Greenville, SC 29607. Tel: 1.864.627.1092. E: info@berliner-playequipment.com. Web: <http://www.berliner-playequipment.com>

2.03 FREESTANDING PLAYGROUND EQUIPMENT

- A. Climber - Shout

1. Product: Subject to compliance with requirements, provide Berliner-Seilfabrik; Shout.06 Model no. 95.190.409.
 2. Frame: Manufacturer's standard stainless steel and rope.
 3. Colors:
 - a. See Furnishing Schedule 01/CPL013
 4. Age Appropriateness: Five through twelve years
- B. Play Tower - Custom
1. Product: Subject to compliance with requirements, provide Berliner-Seilfabrik; DNA L.04 Tower with Jungle Bridge and Tunnel Slide.
 2. Frame: Manufacturer's standard stainless steel and rope.
 3. Colors:
 - a. See Furnishing Schedule 01/CPL013
 4. Age Appropriateness: Five through twelve years
- C. Freeride
1. Product: Subject to compliance with requirements, provide Berliner-Seilfabrik; Freeride Model no. 90.260.802.
 2. Frame: Manufacturer's standard stainless steel and aluminum.
 3. Colors:
 - a. See Furnishing Schedule 01/CPL013
 4. Age Appropriateness: Five through twelve years.
- D. Access Whirl
1. Product: Subject to compliance with requirements, provide Berliner-Seilfabrik; Access Whirl Model No. 90.261.200.
 2. Frame: Manufacturer's standard stainless steel and rope.
 3. Colors:
 - a. See Furnishing Schedule 01/CPL013

4. Age Appropriateness: Five through twelve years
- E. 4.08100 Fish Rocker
1. Product: Subject to compliance with requirements, provide Richter Spielgerate GmbH Fish Rocker Model No. 4.08100.
 2. Materials: Manufacturer's standard wood.
 3. Colors:
 - a. See Furnishing Schedule 01/CPL013
 4. Age Appropriateness: Two through five years
- F. 6.03200 Sailing Ship
1. Product: Subject to compliance with requirements, provide Richter Spielgerate GmbH Sailing Ship Model no. 6.03200.
 2. Materials: Manufacturer's standard wood
 3. Colors:
 - a. See Furnishing Schedule 01/CPL013
 4. Age Appropriateness: Two through five years
- G. A3.63310 Stainless Embankment Slide
1. Product: Subject to compliance with requirements, provide Richter Spielgerate GmbH Stainless Embankment Slide 1m x .45m Model no. A3.63310.
 2. Materials: Manufacturer's standard stainless steel
 3. Colors:
 - a. See Furnishing Schedule 01/CPL013
 4. Age Appropriateness: Two through five years
- H. S 4.03000 Custom Totter Trail Combination
1. Product: Subject to compliance with requirements, provide Richter Spielgerate GmbH Custom Totter Trail Combination Model No. S 4.03000

- a. Components arranged in combination per manufacturer's recommendation:
 - 1) Climbing Trunk H=40cm, Model no. 4.03131
 - 2) Podium 45 degrees H=40cm, quantity (3), Model no. 4.03100
 - 3) Balancing Beam L=3.0m horizontal, Model no. 4.03107
 - 4) Horizontal Net L=2.0m horizontal, Model no. 4.03120
 - 5) PP-Rope L=2.0m horizontal, Model no. 4.03116
 - 6) Inclined Wall with Hand Grips, Model no. 1.10100
 2. Materials: Manufacturer's standard wood
 3. Colors:
 - a. See Furnishing Schedule 01/CPL013
 4. Age Appropriateness: Two through five years
- I. 10.23100 Kaleidoscope
1. Product: Subject to compliance with requirements, provide Richter Spielgerate GmbH Kaleidoscope Model no. 10.23100
 2. Materials: Manufacturer's standard stainless steel
 3. Colors:
 - a. See Furnishing Schedule 01/CPL013
 4. Age Appropriateness: Two through five years
- 2.04 CONCRETE
- A. Concrete Materials and Properties: Comply with requirements in Section 033000.

PART 3 - EXECUTION

3.01 EXAMINATION

- A. Examine areas and conditions, with Installer present, for compliance with requirements for site clearing, earthwork, site surface and subgrade drainage, and other conditions affecting performance of the Work.
 - 1. Do not begin installation before final grading required for placing protective surfacing is completed unless otherwise permitted by Construction Manager.
- B. Proceed with installation only after unsatisfactory conditions have been corrected.

3.02 PREPARATION

- A. Verify locations of playground perimeter and pathways. Verify that playground layout and equipment locations comply with requirements for each type and component of equipment.

3.03 INSTALLATION, GENERAL

- A. General: Comply with manufacturer's written installation instructions unless more stringent requirements are indicated. Anchor playground equipment securely, positioned at locations and elevations indicated.
 - 1. Maximum Equipment Height: Coordinate installed heights of equipment and components with finished elevations of protective surfacing. Set equipment so fall heights and elevation requirements for age group use and accessibility are within required limits. Verify that playground equipment elevations comply with requirements for each type and component of equipment.
- B. Post Set with Concrete Footing: Comply with ACI 301 for measuring, batching, mixing, transporting, forming, and placing concrete.
 - 1. Set equipment posts on concrete footing. Protect portion of posts above footing from concrete splatter. Verify that posts are set plumb or at the correct angle, alignment, height, and spacing.
 - a. Place concrete around posts and vibrate or tamp for consolidation. Hold posts in position during placement and finishing operations until concrete is sufficiently cured.

2. Embedded Items: Use setting drawings and manufacturer's written instructions to ensure correct installation of anchorages for equipment.
3. Concrete Footings: Smooth top, and shape to shed water.

3.04 FIELD QUALITY CONTROL

- A. Perform tests and inspections.
 1. Manufacturer's Field Service: Engage a factory-authorized service representative to inspect components, assemblies, and equipment installations, including connections, and to assist in testing.
- B. Tests and Inspections: For playground and playground equipment and components during installation and at final completion and to certify compliance with ASTM F 1487 or ASTM F3101-15.
- C. Prepare test and inspection reports.
- D. Notify the Construction Manager 48 hours in advance of date and time of final inspection.

3.05 CONTRACT CLOSEOUT

- A. Provide in accordance with Section 017700.

END OF SECTION 116800

NO TEXT ON THIS PAGE

SECTION 129300 - SITE FURNISHINGS

1.01 DESCRIPTION

A. Provide site furnishings as indicated and in compliance with Contract Documents.

1. Section Includes:

- a. Seating (Urban Amenities).
- b. Planters, Leaning Wall, Storage (Urban Amenities).
- c. Off-Shelf Seating (bench type 2, pebble seat, lounge) (Cove Park).
- d. Drinking Water Fountains (Cove Park).
- e. Bike Racks (Cove Park).
- f. Trash/Recycling Receptacles (Cove Park).
- g. Dog Waste Station (Cove Park).

1.02 PAYMENT

A. No separate payment shall be made for performing any Work required under this Section. All costs for Work required by this Section shall be included in the Urban Amenities lump sum and Cove Park lump sum(s) as set forth in Section 012901.

1.03 REFERENCES

A. ASTM International (ASTM):

1. A123/A123M: Standard Specification for Zinc (Hot-Dip Galvanized) Coatings on Iron and Steel Products.
2. A135/A135M: Standard Specification for Electric-Resistance-Welded Steel Pipe.
3. A153/A153M: Standard Specification for Zinc Coating (Hot-Dip) on Iron and Steel Hardware.
4. A924/A924M: Standard Specification for General Requirements for Steel Sheet, Metallic-Coated by the Hot-Dip Process.
5. A1011/A1011M: Standard Specification for Steel, Sheet and Strip, Hot-Rolled, Carbon, Structural, High-Strength Low-Alloy, High-Strength Low-Alloy with Improved Formability, and Ultra-High Strength.

6. C1107/C1107M: Standard Specification for Packaged Dry, Hydraulic-Cement Grout (Non shrink)

7. F1267: Standard Specification for Metal, Expanded, Steel.

B. American Wood Preserver's Association Standard (AWPA):

1. M4: Standard for the Care of Preservative Treated Wood Products.

2. U1: User Specification for Treated Wood.

1.04 RELATED SECTIONS

A. General Conditions Article 4.7 – Shop Drawings and Other Submittals

B. Section 012901 – Measurement and Payment

C. Section 014300 – Quality Requirements

D. Section 016100 – Control of Materials

E. Section 017700 – Contract Closeout

F. Section 061533 - Decking

G. Section 323900 – Manufactured Site Specialties

H. Requirements from the following sections also apply to this Section:

1. Section 033000 – Cast-in-Place Concrete

2. Section 050513 – Shop Applied Coatings for Metal

3. Section 055001 – Site Metal Fabrications

4. Section 321316 – Decorative Concrete Paving

5. Section 321400 – Unit Paving

6. Section 321413 – Porous Precast Concrete Unit Paving

7. Section 321816 – Playground Protective Surfacing

1.05 REQUIREMENTS

A. Contractor Design: All work associated with the items listed below and as identified in this Section with the term “Delegated Design” is to be performed as a delegated design. Contractor is to provide final design, engineering, and fabrication.

1. General: Design and engineering of site furnishing items identified as delegated design items herein and as listed below to be developed in accordance with building code for structural loads and capacities with the design intent as shown in the Contract Drawings.
 - a. Site Furnishings identified as delegated design items herein include:
 - (1) Seating (Urban Amenities)
 - (2) Planters, Leaning Wall, Storage (Urban Amenities)
 2. Contractor to provide all calculations and analysis necessary to complete the Work for delegated design items identified in this Section.
 3. Contractor to coordinate work of others associated to features delegated design items identified in the Section are attached or adjacent to.

- B. Furnish all transportation, labor, materials and equipment to furnish and install all delegated design items identified in the Section and any accessories necessary to complete the Work.

1.06 SUBMITTALS

- A. Submit the following shop drawings in accordance with General Conditions Article 4.7.
- B. Product Data: For each type of product.
- C. Samples: For each exposed product and for each color and texture specified.
- D. Samples for Initial Selection: For units with factory-applied finishes.
- E. Samples for Verification: For each type of exposed finish, not less than 6-inch (150 mm) long linear components and 4-inch (100 mm) square sheet components.
 1. Include wood samples for urban amenities seating, leaning wall & planter
 2. Include powder coated steel samples for urban amenities Seating, Leaning Wall & Planter.
- F. Use same designations indicated on the Contract Drawings.
- G. Material Certificates: For site furnishings.
 1. Wood Preservative Treatment: Include certification by treating plant stating type of preservative solution and pressure process used, net amount of preservative retained, and compliance with applicable standards.
- H. Maintenance Data: For site furnishings to include in maintenance manuals.

- I. Furnish extra materials that match products installed and that are packaged with protective covering for storage and identified with labels describing contents.
 1. Bench Replacement slats: No fewer than two full-size units for each size indicated.
 2. Trash Receptacle Inner Containers: Five full-size units for each size indicated, but no fewer than two units.

1.07 QUALITY ASSURANCE

- A. Comply with the requirements specified in Section 014300.
- B. General
 1. Experienced fabricator(s) or manufacturer(s) will fabricate and install site furnishings and have prior experience in ornamental metal, or woodwork of equal scope and fabrication standards to Project requirements.
 2. Materials, methods of fabrication, fitting, assembly, bracing, supporting, fastening, operating devices, and erection must be in accordance with Contract Drawings and Specifications, approved shop drawings, and be of the highest quality practices of the industry.
 3. Use new and clean materials as specified, having structural properties sufficient to safely sustain or withstand stresses and strains to which materials and assembled work will be subjected.
 4. Fabricate, assemble and neatly and accurately erect all work with smooth finished surfaces.
 5. Field Measurements and Coordination: Verify dimensions with work specified in other sections which adjoins or to which this work will be attached.
 6. Coordinate all work in accordance with Section 323900.
- C. Shop Assembly: Insofar as is practical, fitting and assembly of work must be done in shop in order to minimize field splicing and assembly.
 1. Work that cannot be permanently shop-assembled must be completely assembled, marked for re-assembly and disassembled in shop before shipment to ensure correct assembly in field.
 2. Shop assembles work in largest practical sizes to minimize field work.
 3. Shop fabricated items must correctly fit the field condition. In event that shop-fabricated items to not fit the field condition, the item must be returned to the shop

for correction, unless otherwise approved by Landscape Architect and Construction Manager.

- D. Mockups: Build mockups to verify selections made under submittals, to demonstrate aesthetic effects, and to set quality standards for materials and execution.
 - 1. All mockups are subject to approval by Landscape Architect, Architect and the Construction Manager, the mock-up may be retained as part of the finished work. If mock-up is not retained, remove and dispose of mock-up at the completion of the project.

1.08 DELIVERY STORAGE AND HANDLING

- A. Comply with the requirements specified in Section 016100.
- B. Deliver materials to Project site in original factory wrappings and containers, clearly labeled with identification of manufacturer, brand name, and lot number.
- C. Store materials in original undamaged packages and containers inside well-ventilated area protected from weather, moisture, soiling, extreme temperatures, humidity, and lay flat and block off ground to prevent sagging and warping.
- D. Comply with manufacturer's instructions and recommendations for special delivery, storage, and handling requirements.

1.09 SEQUENCE AND SCHEDULING

- A. Sequence accessory installation with other work to minimize possibility of damage and soiling during remainder of construction period.

PART 2 - PRODUCTS

2.01 BENCH (URBAN AMENITIES)

- A. Products:
 - 1. Custom
- B. Frame: Steel sheet; welded.
- C. Seat and back
 - 1. Material:
 - a. Powder Coated Steel: Thickness ¼ inch
 - b. Sizes as indicated on the Contract Drawings.

- c. Support: Steel – as indicated on the Contract Drawings.
 - d. Wood: Furfurylated Wood Board Lumber
 - e. Lighting: LED
 - 2. Seating Configuration: As indicated on the Contract Drawings.
 - D. Steel Finish: Powder coated, high performance powder on steel, which will require a zinc rich primer powder, followed by the powder coat – in a Super Durable Polyester.
 - 1. Color: As indicated on the Contract Drawings.
 - E. Wood Finish:
 - 1. Stain: As indicated on the Contract Drawings.
 - F. Urban Amenity Custom Bench elements are a delegated design item.
- 2.02 PLANTERS, LEANING WALL, STORAGE (URBAN AMENITIES)
- A. Products:
 - 1. Custom Fabricated
 - B. Steel Facing Surrounds: Steel sheet to match benches
 - C. Wood Facing Surrounds: As indicated on the Contract Drawings.
 - D. Support Frames: Steel; welded.
 - E. Shape and Form: As indicated on the Contract Drawings.
 - F. Steel Finish: Powder coated powder coating, high performance powder on steel, which will require a zinc rich primer powder, followed by the powder coat – in a Super Durable Polyester.
 - 1. Color: As indicated in a site furnishing schedule.
 - G. Wood Finish: As indicated on the Contract Drawings.
 - H. Urban Amenities Planters, Leaning Wall, and Storage elements are delegated design items.
- 2.03 PEBBLE SEAT (COVE PARK)
- A. Products: Subject to compliance with requirements, provide the following:

1. QCP “Pebble” Concrete Seat – Basis of Design
 - a. QCP, 731 Parkridge Avenue, Norco, CA 92860; Telephone: 866-703-3434; Fax: 951-737-7032; Web: www.qcp-corp.com
2. id created, Inc. “Stone” Concrete Seat
 - a. id created, Inc., 1786 La Costa Meadows Drive, Suite 104, San Marcos, CA 92078; Telephone: 760-690-8557; Fax: 760-282-7082; Email: info@idcreated.com; Web: www.idcreated.com
3. EIS Studio “Cast Stone” Pebble Seat
 - a. EIS Studio, Inc., 216 Main Street, Suite B, Venice, CA 90291; Telephone: 310-392-8887; Email: Pebbles@EISStudio.com; Web: www.eisproduct.com
4. Or approved equal.

B. Style:

1. Medium
 - a. Contractor to coordinate weight of pebble seat with wood decking per Section 061533, and to confirm locations and loading of pebble seat as shown in the Contract Drawings are compatible with deck design.

C. Materials:

1. Precast Concrete – Ultra High Performance Concrete (UHPC)

D. Installation Method

1. Freestanding or surface mounted per manufacturer’s instructions and mounting surface type.

E. Finishes:

1. See Furnishing Schedule 01/CPL013

2.04 LOUNGER (COVE PARK)

A. Products: Subject to compliance with requirements, provide the following:

1. Escofet “Rio” Lounger – Basis of Design

- a. Landscape Forms, 7800 E. Michigan Ave., Kalamazoo, MI 49048; Telephone: 800-430-6209; Email: comments@landscapeforms.com; Web: www.landscapeforms.com
 2. QCP “Bonk” Chair
 - a. QCP, 731 Parkridge Avenue, Norco, CA 92860; Telephone: 866-703-3434; Fax: 951-737-7032; Web: www.qcp-corp.com
 3. Wasau Tile “Wave” Lounger
 - a. Wasau, 9001 Bus Hway 51, Rothschild, WI 54474; Telephone: 715-359-3121; Email: wtile@wasautile.com; Web: www.wasautile.com
 4. Or approved equal.
- B. Materials:
1. UHPC Concrete
 - a. Contractor to coordinate weight of lounger with wood decking per Section 061533, and to confirm locations and loading of pebble seat as shown on the Contract Drawings are compatible with deck design.
- C. Installation Method:
1. Freestanding or surface mounted per manufacturer’s instructions and mounting surface type.
- D. Finishes:
1. See Furnishing Schedule 01/CPL013
- 2.05 BENCH TYPE 2 (COVE PARK)
- A. Products: Subject to compliance with requirements, provide the following:
1. Escofet “Tram Recto” Bench – Basis of Design
 - a. Landscape Forms, 7800 E. Michigan Ave., Kalamazoo, MI 49048; Telephone: 800-430-6209; Email: comments@landscapeforms.com; Web: www.landscapeforms.com
 2. QCP “Bonk” Chair
 - a. QCP, 731 Parkridge Avenue, Norco, CA 92860; Telephone: 866-703-3434; Fax: 951-737-7032; Web: www.qcp-corp.com

3. Wasau Tile “Green Alley” Bench
 - a. Wasau, 9001 Bus Hway 51, Rothschild, WI 54474; Telephone: 715-359-3121; Email: wtile@wasautile.com; Web: www.wasautile.com

4. Or approved equal.

B. Style:

1. Recto

C. Materials:

1. Precast Concrete

D. Installation Method:

1. Surface mounted to concrete foundation per manufacturer's instructions with manufacturer supplied two (2) stud bolts.

E. Finishes:

1. See Furnishing Schedule 01/CPL013

2.06 BIKE RACKS (COVE PARK)

A. Products: Subject to compliance with requirements, provide the following:

1. Landscape Forms, “Flo” Bike Rack – Basis of Design
 - a. Landscape Forms, 7800 E. Michigan Ave., Kalamazoo, MI 49048; Telephone: 800-430-6209; Email: comments@landscapeforms.com; Web: www.landscapeforms.com
2. mmcite, “Elk” Bike Rack
 - a. mmcite US, 2905 Westinghouse Blvd, Suite 100, Charlotte, NC 28273; Telephone: 704-995-1942; Email: info@mmcite.com; Web: www.mmcite.com
3. Site Pieces “Duo” Bike Rack
 - a. Jetty14, 3000 Lawrence Street #57, Denver, CO 80205; Telephone: 917716-9242; Web: www.jetty14.com
4. Or approved equal.

B. Bike Rack Construction:

1. Frame: Stainless Steel
2. Installation Method:
3. Embedded per manufacturer's instructions.

C. Finishes:

1. See Furnishing Schedule 01/CPL013

2.07 DRINKING WATER FOUNTAIN (COVE PARK)

A. Products: Subject to compliance with requirements, provide the following:

1. Murdock Manufacturing, "GR Series" Pedestal Mounted Drinking Fountain.
 - a. Model GRQ45-HB3, Quantity one (1)
 - b. Model GRQ45-HB3-PF, Quantity one (1)
2. Or approved equal.

B. Drinking Water Fountain Construction:

1. General: Barrier-free, tri-level, vandal resistant, ADA-compliant in accordance with current ADA Standards when properly installed per manufacturer's recommendations.
2. Frame: Stainless Steel.
3. Installation Method:
 - a. Anchor fountain per manufacturer's instructions and with manufacturer supplied concrete anchors.
4. Option: "-IMG" In-ground mounting plate, to prevent corrosion and account for differential heights in any instance where the mounting unit will be buried. Refer to the Contract Drawings for locations and details. Refer to manufacturer for in-ground mounting connections.

C. Finishes:

1. See Furnishing Schedule 01/CPL013

2.08 TRASH/RECYCLING RECEPTACLE (COVE PARK)

A. Products: Subject to compliance with requirements, provide the following:

1. Dumor, Inc. 40 Gallon Receptacle Assembly with Shield and 20 gallons half-liners, “Hoboken”
 - a. Model D-260-0169-40
 2. Or approved equal.
- B. Installation Method:
1. Surface mount receptacle per manufacturer’s instructions with manufacturer provided epoxy set metal bolts.
- C. Finish: See Furnishing Schedule 01/CPL013
- 2.09 DOG WASTE STATION (COVE PARK)
- A. Products: Subject to compliance with requirements, provide the following:
1. The Sentry Dog Waste Station with Roll Bag
 - a. Zero Waste USA, 12316 World Trade Drive, #102, San Diego, CA 92128; Telephone: 800-789-2563; Fax: 800-789-6619; Web: www.zerowasteusa.com
 2. Superior Pet Waste Eliminator Station
 - a. Pet Waste Eliminator, 13280 NW Freeway, Ste F356, Houston, TX 77040; Telephone: 800-790-8896; Email: customerservice@petwasteeliminator.com; Web: petwasteeliminator.com
 3. Dog Waste Depot
 4. Or approved equal
- B. Installation Method:
1. Embedded per manufacturer’s instructions.
- C. Finish: See Furnishing Schedule 01/CPL013
- 2.10 MATERIALS
- A. Aluminum: Alloy and temper recommended by aluminum producer and finisher for type of use and finish indicated; free of surface blemishes and complying with the following:
1. Rolled or Cold-Finished Bars, Rods, and Wire: ASTM B 211
 2. Extruded Bars, Rods, Wire, Profiles, and Tubes: ASTM B 221

3. Structural Pipe and Tube: ASTM B 429.
 4. Sheet and Plate: ASTM B 209
 5. Castings: ASTM B 26
- B. Steel and Iron: Free of surface blemishes and complying with the following:
1. Plates, Shapes, and Bars: ASTM A36/A36M.
 2. Plates, Shapes, and Bars: ASTM A 36/A 36M.
 3. Steel Pipe: Standard-weight steel pipe complying with ASTM A 53/A 53M, or electric-resistance-welded pipe complying with ASTM A 135/A 135M.
 4. Tubing: Cold-formed steel tubing complying with ASTM A 500/A 500M.
 5. Mechanical Tubing: Cold-rolled, electric-resistance-welded carbon or alloy steel tubing complying with ASTM A 513, or steel tubing fabricated from steel complying with ASTM A 1011/A 1011M and complying with dimensional tolerances in ASTM A 500/A 500M; zinc coated internally and externally.
 6. Sheet: Commercial steel sheet complying with ASTM A1011/A1011M.
 - a. MTL-1: ¼” thk. Powder coated metal
 - b. MTL-2: ¼” thk. Powder coated metal
 - c. MTL-3: ¼” thk. Powder coated metal
 - d. MTL-4: ¼” thk. Powder coated metal
 - e. MTL-5: ¼” thk. Powder coated metal
 - f. MTL-6: ¼” thk. Powder coated metal
 - g. MTL-7: ½” thk. 316 Stainless Steel
 - h. MTL-8: ¼” thk. 316 stainless Steel
 - i. MTL-9: Custom Graphic Lasercut Anodized Aluminum
 7. Perforated Metal: From steel sheet not less than 0.075-inch nominal thickness; manufacturer's standard perforation pattern.
 8. Expanded Metal: Carbon-steel sheets, deburred after expansion, and complying with ASTM F 1267.

9. Malleable-Iron Castings: ASTM A 47/A 47M, grade as recommended by fabricator for type of use intended.
 10. Gray-Iron Castings: ASTM A 48/A 48M, Class 200.
- C. Stainless Steel: Free of surface blemishes and complying with the following:
1. Sheet, Strip, Plate, and Flat Bars: ASTM A 666.
 2. Pipe: Schedule 40 steel pipe complying with ASTM A 312/A 312M.
 3. Tubing: ASTM A 554
- D. Wood: Surfaced smooth on four sides with eased edges; kiln dried, free of knots, solid stock of species indicated.
1. Wood Species:
 - a. Furfurylated Wood Board Lumber: Premium Plus Grade
 2. Certified Wood: Fabricate site furnishings with components produced from wood obtained from forests certified by an FSC-accredited certification body to comply with FSC STD-01-001, "FSC Principles and Criteria for Forest Stewardship."
 3. Finish: Manufacturer's standard transparent wood preservative treatment and sealer
- E. Anchors, Fasteners, Fittings, and Hardware: As indicated on the Contract Drawings.
1. Angle Anchors: For inconspicuously bolting legs of site furnishings, extent as indicated on Contract Drawings.
 2. Antitheft Hold-Down Brackets: For securing site furnishings to substrate; extent as indicated on Contract Drawings.
- F. Lighting: LED lighting including transformers, insulators, and other accessories for operability, with provision for servicing and concealing connections to building electrical system. Use tight or sealed joint construction to prevent unintentional light leakage.
1. LED Flexible Strip Lighting: As per Section 265619
 2. Power: 12VDC Power Supply White (6500 K, 5000 K, 3500 K)
- G. Non-shrink, Nonmetallic Grout: Premixed, factory-packaged, non-staining, noncorrosive, nongaseous grout complying with ASTM C1107/C1107M; recommended in writing by manufacturer, for exterior applications.
- H. Erosion-Resistant Anchoring Cement: Factory-packaged, non-shrink, non-staining, hydraulic-controlled expansion cement formulation for mixing with potable water at

Project site to create pourable anchoring, patching, and grouting compound; resistant to erosion from water exposure without needing protection by a sealer or waterproof coating; recommended in writing by manufacturer, for exterior applications.

- I. Galvanizing: Where indicated for steel and iron components, provide the following protective zinc coating applied to components after fabrication:
 1. Zinc-Coated Tubing: External, zinc with organic overcoat, consisting of a minimum of 0.9 oz./sq. ft. of zinc after welding, a chromate conversion coating, and a clear, polymer film. Internal, same as external or consisting of 81 percent zinc pigmented coating, not less than 0.3 mil thick.
 2. Hot-Dip Galvanizing: According to ASTM A 123/A 123M, ASTM A 153 /A 153M, or ASTM A 924/A 924M.

2.11 WOOD-PRESERVATIVE-TREATED MATERIALS

- A. Preservative Treatment: Pressure-treat wood according to AWWA U1 and the following:
 1. Use preservative chemicals acceptable to Architect/Engineer and containing no arsenic or chromium. Use chemical formulations that do not bleed through or otherwise adversely affect finishes. Do not use colorants to distinguish treated materials from untreated materials.
 2. Kiln-dry lumber and plywood after treatment to a maximum moisture content, respectively, of 19 and 15 percent. Do not use materials that are warped or do not comply with requirements for untreated materials.

2.12 FABRICATION

- A. Metal Components: Form to required shapes and sizes with true, consistent curves, lines, and angles. Separate metals from dissimilar materials to prevent electrolytic action.
- B. Welded Connections: Weld connections continuously. Weld solid members with full-length, full-penetration welds and hollow members with full-circumference welds. At exposed connections, finish surfaces smooth and blended, so no roughness or unevenness shows after finishing and welded surface matches contours of adjoining surfaces.
- C. Pipes and Tubes: Form simple and compound curves by bending members in jigs to produce uniform curvature for each repetitive configuration required; maintain cylindrical cross section of member throughout entire bend without buckling, twisting, cracking, or otherwise deforming exposed surfaces of handrail and railing components.
- D. Preservative-Treated Wood Components: Complete fabrication of treated items before treatment if possible. If cut after treatment, apply field treatment complying with AWWA M4 to cut surfaces.

- E. Exposed Surfaces: Polished, sanded, or otherwise finished; all surfaces smooth, free of burrs, barbs, splinters, and sharpness; all edges and ends rolled, rounded, or capped.
- F. Factory Assembly: Assemble components in the factory to greatest extent possible to minimize field assembly. Clearly mark units for assembly in the field.

2.13 GENERAL FINISH REQUIREMENTS

- A. Appearance of Finished Work: Noticeable variations in same piece are not acceptable. Variations in appearance of adjoining components are acceptable if they are within the range of approved Samples and are assembled or installed to minimize contrast.

2.14 STEEL AND GALVANIZED-STEEL FINISHES

- A. High-Performance Super Durable Powder Finish: Two-coat powder coating system, including zinc rich powder primer followed by a Super Durable powder complying with AAMA 2604 and containing 100 percent Super Durable Polyester resin. Prepare, pretreat, and apply coating to exposed metal surfaces to comply with coating and resin manufacturers' written instructions.

PART 3 - EXECUTION

3.01 EXAMINATION

- A. Examine areas and conditions, with Installer and Construction Manager present, for compliance with requirements for correct and level finished grade, mounting surfaces, installation tolerances, and other conditions affecting performance of the Work.
- B. Proceed with installation only after unsatisfactory conditions have been corrected.

3.02 INSTALLATION, GENERAL

- A. Comply with manufacturer's written installation instructions unless more stringent requirements are indicated. Complete field assembly of site furnishings where required.
- B. Unless otherwise indicated, install site furnishings after landscaping and paving have been completed.
- C. Install site furnishings level, plumb, true, and securely anchored at locations indicated on the Contract Drawings.
- D. Post Setting: Set cast-in support posts in concrete footing with smooth top, shaped to shed water. Protect portion of posts above footing from concrete splatter. Verify that posts are set plumb or at correct angle and are aligned and at correct height and spacing. Hold posts in position during placement and finishing operations until concrete is sufficiently cured.

- E. Posts Set into Voids in Concrete: Form or core-drill holes for installing posts in concrete to depth recommended in writing by manufacturer of site furnishings and 3/4-inch (19 mm) larger than OD of post. Clean holes of loose material, insert posts, and fill annular space between post and concrete with non-shrink, nonmetallic grout, mixed and placed to comply with anchoring material manufacturer's written instructions, with top smoothed and shaped to shed water.

3.03 CONTRACT CLOSEOUT

- A. Provide in accordance with Section 017700.

END OF SECTION 129300

SECTION 133400 - FABRICATED ENGINEERED STRUCTURES

PART 1 - GENERAL

1.01 DESCRIPTION

- A. This Section includes all material and labor required in the fabrication and placement of the “Portland Loo” facility as shown on Contract Drawings.

1.02 SCOPE

- A. Building materials shall be supplied by Portland Loo Inc. Portland Loo Inc. 2550 NW 25th Place Portland, OR 97210. Phone: 503-226-3968; Fax: 503-242-2446, E-mail: emadden@theloo.biz or approved equal.
- B. Generally, work will include site preparation, installation of underground plumbing, foundation and pad construction, and building placement.
- C. Requests for substitution shall be submitted to the Construction Manager a minimum of 10 days prior to bid date. The request shall be a complete package as noted below:
 - 1. Documents to be in CSI format
 - 2. Product literature/or brochure illustrating appearance, layout, building shape, materials, and assembly manual
 - 3. Certificate from manufacturer that the proposed substitution is in compliance with all provisions of this Section.
 - 4. List of five (minimum) completed projects, including contact names and phone numbers, that are similar in scope and magnitude.
 - 5. Proof of at least five years of experience as a pre-engineered building supplier.

1.03 PAYMENT

- A. No separate payment shall be made for performing any Work required under this Section. All costs for Work required by this Section shall be included in the applicable lump sum(s), unit price(s), or allowance(s) as set forth in Section 012901.

1.04 RELATED SECTIONS

- A. General Conditions Article 4.7 – Shop Drawings and Other Submittals
- B. Section 012901 – Measurement and Payment

C. Section 014300 - Quality Requirements

D. Section 017700 - Contract Closeout

1.05 DOCUMENTATION

A. Provide all necessary documents for approval and installation.

1. Construction documents include:

a. Detailed plans

b. Specifications

B. Floor plan dimensions: 6'-4" W x 10'-7" L x 8'-9 1/2" Tall

1.06 REFERENCES

A. ASTM A-240

B. ASTM A-554

C. ASTM A650 Grade 60

D. ADAAG

E. CBC

F. CSFM

G. ANSI

H. ASME

I. MILITARY SPECIFICATION V-29193

1.07 DESIGN CRITERIA

A. Members to withstand dead load, design loads and wind loads as calculated in accordance with the latest version of state and local building codes.

B. Portland Loo Inc. reserves the right to make substitutions of equivalent materials and items without notice.

C. Design loads: Refer to drawings

D. Accessibility: Design shall meet the Americans with Disabilities Act Accessibility Guidelines (ADAAG) and California Building Codes.

1.08 SUBMITTALS

- A. Submit the following shop drawings in accordance with General Conditions Article 4.7.
- B. Indicate profiles, sizes, spacing(s), location of structural members, connections, attachments, openings, fasteners, loads and reinforcements.
- C. Indicate wall and roof system dimensions, panel layout, general construction details, anchorages and method of anchorage, and method of installation.
- D. Submit manufacturer’s installation instructions, manuals, and data sheets.
- E. The “Portland Loo Restroom” building and all its associated components shall be warranted against defects in materials and workmanship for a period of one year from date of final acceptance.

1.09 QUALITY ASSURANCE

- A. Comply with the requirements specified in Section 014300.

1.10 WORK SUPPLIED BY INSTALLER

- A. The items noted as “*supplied by installer*” shall be supplied by the building installer.
- B. Refer to drawings for quantities, dimensions, locations, and installations methods for items described in this Section.
- C. The installer shall supply any parts not listed in the Portland Loo Inc. submittal, including but not limited to items specified in the final plans and items required by building codes.
- D. The installer shall be responsible for ensuring that the concrete foundation and slab are adequate for the site conditions and the purpose for which the building and foundation/slab are intended.
- E. All equipment, labor, and trades to unload the building, excavate the site, install the underground plumbing, build concrete forms, supply and install the reinforced concrete footings and slab, and install the building and fixtures.
- F. 1-1/2-inch minimum water line is required to supply the toilet and hand wash facility shall be included. At 1-1/2-inch the water line must have no longer that 100’ run to the water meter. (All dimensions and will be site specific).
- G. 4-inch ABS sanitary sewer line is required to service the restroom shall be included.
- H. The building installer is responsible for the supply and installation of all other items indicated on final plans or required by building codes. Portland Loo Inc. does not supply these items.

PART 2 - PRODUCTS

2.01 CONCRETE

- A. Slab and footings *supplied by installer* - 4000 psi strength at 28 days ii. ASTM A615 grade 60 rebar reinforcement.

2.02 STEEL

- A. Prefabricated building frame posts supplied by Portland Loo Inc. The prefabricated steel frame is to be constructed of 3” ASTM 304L stainless tube steel.
- B. Prefabricated roof system supplied by Portland Loo Inc.
 - 1. The prefabricated roof will consist of 3/16-inch ASTM A304L Stainless Steel plate, with ¼-inch ASTM A304L Stainless Steel plate formed around the exterior for fascia.
 - 2. The prefabricated roof system will include (4) 2000# lifting eyes that will act as pick points for the prefabricated roof system. In addition, (4) 1” x 3” slotted drains for water runoff shall be included.
- C. Wall panels supplied by Portland Loo Inc.
 - 1. The wall panels will be 3/16-inch ASTM A304 Stainless steel structural plate steel.
 - 2. All wall panels are channel formed around the perimeter and bolted to the prefabricated building frame.

2.03 OPENINGS

- A. Louvers supplied by Portland Loo Inc.
- B. The frame and louvers will be fabricated from ¼-inch 304/304L ASTM A240A stainless steel plate. Louver panels will be bolted to steel fabricated frames and columns.
- C. Skylight supplied by Portland Loo Inc. Pre-assembled 304/304L ASTM A240A stainless steel frame with 1/8-inch translucent double pane 1/8-inch tempered glass. Base frame to be seal welded to roof and glass panel secured using 304/304L ASTM removable cover plate with drip edge.
- D. Main door supplied by Portland Loo Inc.
 - 1. 3/16-inch 304/304L ASTM A240A stainless steel plate with formed edges around perimeter, 3/16-inch Formed channel stiffeners, and an integrated door louver fabricated from 3/16-inch 304/304L ASTM A240A stainless steel plate.

2. Door hinges shall be barrel hinges with zerk fittings welded to ¼” x 3” x 5” plates. Hinges shall be attached with 3/8-16 vandal resistant security screws.
3. Lever lock shall be Best HD door lever 9k series complies with ADA and California Fire Safety Code (CSFM). Dormitory locking feature to keep door from locking after departure. Satin Chrome finish. Installation on-site with supplied hardware.
4. Door closer shall be Norton 9540 689 inside surface mounted door closer with fast power adjust, shall comply with ADA requirements. Door closer shall be tested and certified under ANSI Standard A156.4, grade one.

E. Mechanical room doors supplied by Portland Loo Inc.

1. 3/16” ASTM A304 Stainless Steel plate.
2. Door hinges shall be type 304 stainless steel piano hinge without holes. .075” thick, 3” width, ¼” pin diameter. Attached with stainless steel screws.
3. Locks to be (2) Stanley BEST 8T-2-7-L-STK-626 Grade 1 Cylinder/Blank Deadbolt with a 2-3/8 Backset in Satin Chrome. Cores passed ANSI/BHMA A156.11, grade 1 testing. Satin chrome finish to accept Best large format IC cores by installer. Qty 1 per door.

2.04 PLUMBING

A. Toilet supplied by Portland Loo Inc.

1. Acorn Dura-Ware 2105 Series wall hung, 16-ga. type 304 stainless steel. Seamlessly welded from a one piece vandal resistant unit. Fully enclosed trap, Siphon Jet flushing action, and integral elongated seat. Designed for low consumption with appropriate flush valve.
2. Designed to meet or exceed ASME 112.19.3-2008 and CSA B45.4-2008 for hydraulic performance and ASME 112.19.3-2008 for physical dimensions.
3. Exposed surfaces polished to a satin finish.
4. Sloan manual concealed flushometer for wall hung water closets, 14.5" rough in, rear spud, offset activation, 1.28 gpf/4.8 Lpf, wall box.
5. Valve body, cover, tailpiece and control stop shall be in conformance with ASTM alloy classification for semi-red brass.
6. Valve shall be in compliance to the applicable sections of ASSE 1037, ANSI/ASME 112.19.2, and military specification V-29193.
7. ADA compliant non-hold-open feature type actuator.

- B. Flushometer supplied by Portland Loo Inc.
- C. Exterior hand wash station supplied by Portland Loo Inc.
 - 1. Acorn BPH chrome plated brass filler spout with push button actuator and a pneumatic valve.
 - 2. Acorn 03-M pneumatic metering valve.
 - 3. Acorn PBH air-trol push button requires less than 5-lb force operation.

2.05 FURNISHINGS

- A. Grab bars supplied by Portland Loo Inc.
 - 1. WH Cress 6800 series stainless steel grab bars, 4-ga, satin finish 1-1/2-inch outside diameter 22-ga round snap on concealed mount.
- B. Toilet paper dispenser supplied by Portland Loo Inc.
 - 1. One, 2-roll 12ga 304 Stainless steel, rolling dispenser with 1-inch long, lockable.
 - 2. Hand sanitizer dispenser supplied by Portland Loo Inc.
 - 3. McMaster 2783K26 Chrome-plated Gravity-Flow Valve fed from interior reservoirs.
 - 4. High impact polystyrene soap vessel liner, chrome-plated brass soap valve with ABS mechanism that requires less than 5lbs of force.
 - 5. 32 oz bottle soap reservoir secured inside locked back water closet space.
- C. Signs supplied by Portland Loo Inc.
 - 1. Restroom entry signs shall be fastened to exterior walls alongside entry doors to meet ADA requirements, Hand Sanitizer sign on inside above hand sanitizer pump, Hand Wash sign on outside above hand wash control valve.
 - 2. Graphics and grade 2 Braille on injection molded plastic signs, black or blue color. Unisex design.
 - 3. Dimensions: Qty (1) 9” wide by 8” tall by 1/8” thick.
 - 4. Dimensions: Qty (1) 8” wide by 2” tall by 1/8” thick “Hand Sanitizer” sign
 - 5. Dimensions: Qty (1) 8” wide by 2” tall by 1/8” thick “Hand Wash” sign

2.06 FINISHES

- A. All exposed Stainless steel and steel surfaces are sandblast finish and two coats of Tiger Drylac Anti-graffiti Powder coat clear finish or one coat exterior color and one coat Tiger Drylac Anti-graffiti Powder coat clear finish.
 - 1. Structural fill per geotechnical reports (by others).
 - 2. Site grading and structural fill (by others).
 - 3. Building foundation structural fill (by others).
 - 4. Structural fill to bring the site to grade and compaction (by others)

2.07 ELECTRICAL

- A. Electrical system and components Supplied by Portland Loo Inc. - Furnished and wired by electrical contractor licensed in the state of Oregon. Wiring, conduit, electrical enclosures are UL listed.
 - 1. Exterior lighting – LED Flexlight light rope, 3 Watts per foot. Blue lighting.
 - 2. Interior Lighting – Two 24 Inch Current USA TrueLumen Pro Deepwater Blue 453nm Actinic LED Strip Lights
 - 3. Lighting control – Photoeye – 24 VDC Wattstopper Model #EM-24A2.
 - 4. Electrical heat trace and Thermostat – Heatline Kompensator heat trace with 6 watts per foot and 24V DC powered. Heat trace controlled by Engenity Solitat II Solid State DC thermostat set to close at 40 deg Fahrenheit or below, 6V to 24V operation and 20Amp load capability.
 - 5. Meter Panel (non-solar units if requested) – Cooper AW114TB UL 414 listed and complies with C12.7. Only on Non-solar Portland Loo.
 - 6. Sola 24 V DC power supply 110V AC input, 240 Watt – model SDN 10-24-100C. Only on non-solar Portland Loo.
 - 7. Electrical Enclosure - NEMA (include wording for grounding by others) Including breakers and fusing, wire terminations, Control relays and Sola 24V DC power supply (non-solar units).

PART 3 - EXECUTION

3.01 SITEWORK

- A. Refer to site plan.
 - 1. Structural fill for footing foundation and slab grading per plan (by installer).

2. Sidewalks (by installer).

3.02 BUILDING ERECTION

- A. Verify site conditions are prepared for building installation.
- B. Do not field cut or alter structural members without approval of Architect or Engineer.
- C. Install in accordance with manufacturer's instructions.

3.03 CONTRACT CLOSEOUT

- A. Provide in accordance with Section 017700.

END OF SECTION 133400

SECTION 260519 - WIRES AND CABLES LESS THAN 600V

PART 1 - GENERAL

1.01 SUMMARY

- A. This Section describes materials and installation of wires and cables rated 600 volts and below.

1.02 PAYMENT

- A. No separate payment shall be made for performing any Work required under this Section. All costs for Work required by this Section shall be included in the applicable lump sum, unit price(s), or allowance(s) as set forth in Section 012901.

1.03 RELATED SECTIONS

- A. General Conditions Article 4.7 – Shop Drawings and Other Submittals.
- B. General Conditions Article 4.10 – Testing.
- C. Section 012901 – Measurement and Payment.
- D. Section 014300 - Quality Requirements.
- E. Section 016100 - Control of Materials.
- F. Section 017700 - Contract Closeout.
- G. Section 260526 - Grounding and Bonding for Electrical Systems

1.04 SUBMITTALS

- A. Submit shop drawings and manufacturers' product data in accordance with General Conditions Article 4.7.
- B. Submit material list for each conductor type. Indicate insulation material, conductor material, voltage rating, manufacturer, and other data pertinent to the specific cable, such as shielding, number of pairs, and applicable standards.
- C. All testing results.

1.05 QUALITY ASSURANCE

- A. Comply with the requirements specified in Section 014300.

1.06 DELIVERY STORAGE AND HANDLING

- A. Comply with the requirements specified in Section 016100.

PART 2 - MATERIALS

2.01 LOW-VOLTAGE WIRE

- A. Conductor material shall be copper.
- B. Low-voltage cable for use at 600 volts or less shall be 600-volt insulated, Type THWN-2, and rated for continuous operation at 90°C wet and dry.
- C. Use No. 12 AWG minimum conductor size for power cable above or equal 120VAC.
- D. Use No. 14 AWG minimum conductor size for control circuits.
- E. Conductors for lighting and receptacle circuits that are No. 10 AWG and smaller shall be solid. All other conductors shall be stranded.

2.02 MULTICONDUCTOR CABLE

- A. Conform to UL Type TC cable and UL 1277.
- B. Conductors shall be stranded copper and UL rated VW-1.
- C. Cable shall meet ICEA T-29-520 210,000 Btu/hour vertical tray flame test.
- D. Provide integral green ground wire in addition to wires shown in drawings.

2.03 CONTROL CABLE

- A. Control cable shall conform to UL standards. The conductors shall be bare copper, No. 14 AWG minimum conductor size. Insulation shall be 15-mil PVC with a nylon jacket not less than 4 mils thick at any point. The insulated conductors shall conform to UL standards for 600 volts rated Type THHN or THWN. The overall jacket for the multiconductor cable shall be PVC. The colors of the individual conductors shall conform to the requirements of NEMA WC7 as follows:

1	—	Black	11	—	Brown/Black
2	—	Red	12	—	Black/Red
3	—	Blue	13	—	Blue/Red
4	—	Orange	14	—	Orange/Red
5	—	Yellow	15	—	Yellow/Red
6	—	Brown	16	—	Brown/Red
7	—	Red/Black	17	—	Black/Blue
8	—	Blue/Black	18	—	Red/Blue
9	—	Orange/Black	19	—	Orange/Blue
10	—	Yellow/Black			

2.04 TWISTED-SHIELDED CABLE

- A. Single-pair cables shall be two No. 18 AWG and single triads shall be three No. 18 AWG stranded tinned-copper conductors individually insulated with fully color-coded PVC rated at 600 volts; insulated conductors twisted together and shielded with a spiral-wound metal foil tape overlapped for 100 percent shielding. Outer jacket shall be PVC.
- B. Multiple-pair cables shall have number of pairs specified with each pair being two No. 18 AWG stranded tinned-copper conductors individually insulated with PVC rated at 300 volts. Conductor pairs shall have insulation pigmented black and white with white conductor numerically printed for group identification. Each pair and its No. 20 AWG stranded tinned-copper drain wire shall be twisted together and shielded with an aluminum-polyester tape overlapped for 100 percent shielding. Provide a cable shield of 2.35-mil aluminum-polyester tape overlapped to provide 100 percent shielding and a No. 18 AWG copper drain wire. Provide a flame-retardant PVC jacket per UL 13, 105 degrees C temperature rating.

2.05 DIRECT BURIAL CABLES

- A. Direct burial cables for use at 600 volts and less shall have UL labeling "Type USE" and RHW insulation with black, neoprene sheath meeting the physical requirements and minimum thickness requirements of ICEA S-19-81.

2.06 GROUNDING CONDUCTORS - BARE COPPER

- A. Refer to Section 260526 for bare copper grounding conductors.

2.07 CONDUCTOR TAGS

- A. Provide self-extinguishing heat-shrink individual or sleeved, nonmetallic, snap-on type.

- B. Plastic Adhesives: Plastic adhesives for color coding shall be 7-mil minimum thick, flame-retardant, weather-resistant tape, resisting abrasion, UL rays, moisture, alkalies, solvents, and acids. Adhesives shall meet the requirements of UL 510.

PART 3 - EXECUTION

3.02 LOW-VOLTAGE WIRE INSTALLATION

- A. Install wiring and cable in conduit and terminate unless otherwise noted.
- B. To reduce pulling tension in long runs, coat cables with pulling compound recommended by the cable manufacturer before being pulled into conduits.
- C. Remove debris and moisture from the conduits, boxes, and cabinets prior to cable installation.
- D. Group conductors No. 1/0 and smaller in panelboards, cabinets, pull boxes, motor control centers, and switchboard wireways; tie with plastic ties; and fan out to terminals. Lace conductors No. 2/0 and larger with mainline.

3.03 IDENTIFICATION

- A. Color Coding of Low-Voltage Wire: Provide color coding as follows:

Phase	240/120 Volts	208/120 Volts	240 Volts	480/277 Volts
Phase A	Black	Black	Black	Brown
Phase B	Red	Red	Red	Orange
Phase C	---	Blue	Blue	Yellow
Neutral	White	White	White	Gray
Ground	Green	Green	Green	Green

- B. Phase conductors No. 10 AWG and smaller and neutral/ground conductors No. 6 and smaller shall have factory color coding with solid color insulation. Do not use onsite coloring of ends of conductors or apply colored plastic adhesives in lieu of factory color coding. Larger conductors may have onsite application of colored plastic adhesives at ends of conductors and at each splice.
- C. Control wires shall have colored insulation. Separate color codes for each wire shall be provided in each conduit that has up to seven wires. Conduits with more than seven wires shall have at least seven types of colored insulation.
- D. Tagging of Conductors: Tag control wires and instrument cables in panels, pull boxes, wireways, and at control device. Tag control wires and instrument cables with same

wire numbers as on the shop drawing submittals. Tag power wires in pull boxes and wireways where there is more than one circuit. Tag power conductors with motor control center or panelboard number and circuit numbers.

3.04 LOW-VOLTAGE WIRE SPLICES

- A. Solid Conductors: Use 3M "Scotchlok," Ideal "Super Nut," Buchanan B-Cap, or equal. Seal splices in underground handholes and pull boxes and in light poles with individual sealing packs of Scotchcast Brand 400 Resin or equal.
- B. Stranded Conductors No. 8 and Larger: Use T & B "Locktite" connectors, Burndy Versitaps and heavy-duty connectors, O.Z. solderless connectors, A Hubbell Co. Connectors, or equal.
- C. Stranded Conductors No. 10 and Smaller: Use crimp connectors with tools by same manufacturer and/or UL listed for connectors of all stranded conductors.
- D. Retighten bolt-type connectors 24 to 48 hours after initial installation and before taping. Tape connections made with non insulated-type connectors with rubber-type tape, one and one-half times the thickness of the conductor insulation, then cover with Scotch 33 tape.

3.05 LOW-VOLTAGE WIRE TERMINATIONS

- A. Terminate wires and cables at each end.
- B. Provide ring tongue, nylon- or vinyl-insulated copper crimp terminals for termination on screw-type terminals, except for light switches and receptacles. Utilize installation tools recommended by the crimp manufacturer.
- C. Terminal lugs shall be electro-tin plated copper compression type or spring compression type with a corrosion protection coating. Provide color-coded system on terminal and die sets to provide the correct number and location of crimps. Permanent die index number shall be embossed on completed crimp for inspection purposes.
- D. Terminal lugs shall be UL listed and of the split bolt or bolted split sleeve type in which the bolt or setscrew does not bear directly on the conductor. Tongues shall have NEMA standard drilling.
- E. Tighten screws and bolts to the value recommended by the manufacturer.

3.06 FIELD TESTING

- A. Refer to General Conditions Article 4.10.

- B. Perform insulation resistance test on all circuits and feeders with No. 10 size conductors and larger. Utilize a 1,000-volt d-c megohmmeter for 600-volt insulated conductors.
- C. Test each complete circuit prior to energizing. Insulation resistance between conductors and between each conductor and ground shall not be less than 25 megohms. Repair or replace wires or cables in circuits that do not pass this test and repeat the test.
- D. Evaluate ohmic values by comparison with conductors of same length and type.
- E. Inspect shielded cables for proper shield grounding, proper terminations, and proper circuit identifications.
- F. Inspect control cables for proper termination and proper circuit identification.
- G. In cables terminated through window-type CTs, verify that neutrals and grounds are terminated for correct operation of protective devices.

3.07 CONTRACT CLOSEOUT

- A. Provide in accordance with Section 017700.

END OF SECTION 260519

SECTION 260526 - GROUNDING AND BONDING FOR ELECTRICAL SYSTEMS

PART 1 - GENERAL

1.01 DESCRIPTION

- A. Provide a grounding system, including conductors, ground rods and connections as indicated and specified in accordance with the National Electrical Code Article 250 and the National Electrical Safety Code.

1.02 PAYMENT

- A. No separate payment shall be made for performing any Work required under this Section. All costs for Work required by this Section shall be included in the applicable lump sum(s), or allowance(s), as set forth in Section 012901.

1.03 RELATED SECTIONS

- A. General Conditions Article 4.7 – Shop Drawings and Other Submittals.
- B. General Conditions Article 4.10 – Testing.
- C. Section 012901 – Measurement and Payment.
- D. Section 014300 - Quality Requirements.
- E. Section 016100 - Control of Materials.
- F. Section 017700 - Contract Closeout.

1.04 REFERENCES

- A. American National Standards Institute (ANSI)/Institute of Electrical and Electronics Engineers (IEEE):
 - 1. ANSI/IEEE C2: National Electrical Safety Code.
- B. ASTM International (ASTM):
 - 1. B3: Standard Specification for Soft or Annealed Copper Wire.
 - 2. B8: Standard Specification for Concentric-Lay-Stranded Copper Conductors, Hard, Medium-Hard, or Soft.
 - 3. B33: Standard Specification for Tinned Soft or Annealed Copper Wire for Electrical Purposes.

- C. Institute of Electrical and Electronics Engineers (IEEE):
 - 1. Standard 81: Guide for Measuring Earth Resistivity, Ground Impedance, and Earth Surface Potential of a Ground System.
- D. National Fire Protection Association (NFPA):
 - 1. 70: National Electrical Code.
 - 2. 780: Lightning Protection Code.
- E. Underwriters Laboratories (UL):
 - 1. 467: Standard for Grounding and Bonding Equipment.

1.05 SUBMITTALS

- A. Submit the following in accordance with General Conditions Article 4.7
- B. Submit catalog and dimensional data for the following:
 - 1. Ground rods
 - 2. Exothermic welding
 - 3. Connector hardware
- C. All testing results

1.06 QUALITY ASSURANCE

- A. Comply with the requirements specified in Section 014300.

1.07 DELIVERY STORAGE AND HANDLING

- A. Comply with the requirements specified in Section 016100.

PART 2 - PRODUCTS

2.01 MATERIALS AND COMPONENTS

- A. Conductors:
 - 1. Provide copper grounding conductors bare or insulated, sized as indicated. When not indicated on the Contract Drawings, provide in accordance with the NEC.

Provide protection of conductors in locations where physical damage would result from direct exposure.

2. Unless noted otherwise, all conductors No. 8 AWG and larger shall be stranded, Class B in accordance with ASTM B8.
 3. Uninsulated conductors shall be bare copper in accordance with ASTM B3, tinned in accordance with ASTM B33.
 4. Use tinned-coated in corrosive environments including when buried in earth or embedded in concrete.
- B. Provide ground clamps as per UL listed Ground Rods:
1. Ground rods shall conform to the requirements of NFPA 70 and UL Standard 467.
 2. Ground rods shall be copper-clad steel rods not less than 3/4 inch (19 mm) in diameter and not less than 10 feet long per section.
 3. Ground rods shall be clean and smooth with the following characteristics:
 - a. Cone-shaped point on the first section.
 - b. Die-stamped near the top with the name or trademark of the manufacturer and the length of the rod in millimeters or feet.

PART 3 - EXECUTION

3.01 EXOTHERMIC WELDING

- A. Welding shall be by the exothermic process.
- B. Within the welding procedure, include the proper mold and powder charge and conform to the manufacturer's recommendations.
- C. Welding processes shall be the exothermic fusion type that will make a connection without corroding or loosening.
- D. The welding process shall join all strands and not cause the parts to be damaged or weakened.
- E. Completed connection or joint shall be equal or larger in size than the conductors joined and have the same current-carrying capacity as the largest conductor.
- F. Paint buried ground connection with a bitumastic paint.

3.02 INSTALLATION OF GROUNDING AND BONDING CONDUCTORS

- A. Install grounding conductors so that they will not be exposed to physical damage. Install connections firm and tight. Arrange conductors and connectors so no strain on connections.
- B. Bury grounding and bonding conductors 30 inches deep. Bring loops or taps up for connection to equipment or other items to be grounded.
- C. Buried and concealed ground connections shall use exothermic welding.
- D. Make accessible connections to structural members by exothermic welding process or by bolted connector. Connections to equipment or ground bus by bolted connectors.

3.03 INSTALLATION OF GROUND RODS

- A. The top of the rod shall be installed 12 inch below the ground surface.
- B. Make connection to overall grounding system, if accessible.
- C. Ensure that final resistance of interconnected ground system is 5 ohms, or less. Measure ground resistance in normally dry conditions, and not less than 48 hours after rainfall.

3.04 EQUIPMENT GROUNDING AND BONDING

- A. Grounding and Bonding conductors installed in conduit with insulated conductors to be furnished with green, 600 volt insulation. Grounding and Bonding conductors are in addition to and not to be considered as the neutral wire of the system.
- B. Connect a grounding and bonding conductor between panelboard and grounding system. Where a grounding bar is furnished with panelboard, connect grounding and bonding conductor to bar.
- C. Pendant panel shall be grounded.
- D. Conduits entering metal enclosures shall utilize bonding type locknuts and grounding bushings. Locknuts that gouge into the metal enclosures are not acceptable.
- E. Lighting panel and receptacle circuits shall be grounded in accordance with requirements of National Electric Safety Code.
- F. Three phase winch motors frame and boxes shall be grounded.

3.05 SITE TESTING

- A. Refer to General Conditions Article 4.10.

- B. Ground resistance tests must be made during dry weather and no sooner than 48 hours after rainfall. Conditions of soil and weather shall be documented on test forms.
- C. Conduct tests using the ratio method that measures the ratio of the resistance to earth of an auxiliary test electrode to the series resistance of the electrode under test and a second auxiliary electrode. Perform measurements in accordance with IEEE Standard 81.
- D. Indicating instrument must be self-contained and include a direct-current generator, synchronized current and potential reversers, crossed-current and potential coils, direct-reading ohmmeter, series resistors, and range-selector switch. Calibrate direct-reading ohmmeter for ranges of 0 to 20 ohms and 0 to 200 ohms.
- E. Place auxiliary grounding electrodes in accordance with instrument manufacturer's recommendations but not less than 50 feet apart, in accordance with IEEE Standard 81.
- F. Perform continuity test on all electrical equipment to ensure that the ground terminals are properly grounded to the grounding system.
- G. Furnish copies of test reports on ground system.

3.06 CONTRACT CLOSEOUT

- A. Provide in accordance with Section 017700.

END OF SECTION 260526

NO TEXT ON THIS PAGE

SECTION 260533 - CONDUITS AND JUNCTION BOXES

PART 1 - GENERAL

1.01 DESCRIPTION

- A. Provide complete Conduit systems, with matching accessories, fittings, Junction boxes, and other hardware, as indicated and specified. When non-metallic Conduits are specified, provide green insulated grounding conductor sized per National Electrical Code (NEC) requirements.
- B. Provide Conduit in accordance with the following:
 - 1. For outdoor application when conduits are exposed, use PVC coated Rigid Metal Conduit (RMC).
- C. For concrete slabs or walls, use PVC.
- D. All conduits shall be installed in accordance with the criteria described in this section.
 - 1. For outdoor application, use Type 316 stainless steel, PVC coated support systems. Provide hot-dipped galvanized supports for galvanized conduit.
- E. Aluminum conduit and boxes are not acceptable products.

1.02 PAYMENT

- A. No separate payment shall be made for performing any Work required under this Section. All costs for Work required by this Section shall be included in the applicable lump sum(s), unit price(s), or allowance(s), as set forth in Section 012901.

1.03 REFERENCES

- A. National Electrical Manufacturers Association (NEMA):
 - 1. RN-1: Polyvinyl Chloride (PVC) Externally Coated Galvanized Rigid Steel Conduit and Intermediate Metal Conduit.
 - 2. TC-2: Electrical Plastic Tubing (EPT) and Conduit (EPC-40 and EPC-80).
 - 3. TC-3: Polyvinyl Chloride (PVC) Fittings for Use with Rigid PVC Conduit and Tubing.
 - 4. FB 2.10: Selection and Installation Guidelines for Fittings for use with Non-Flexible Conduit or Tubing.

- B. National Fire Protection Association (NFPA):
 - 1. 70: National Electrical Code (NEC).
- C. Occupational Safety & Health Act (OSHA).
 - 1. Regulation 29CFR1910.
- D. Underwriter's Laboratories, Inc. (UL):
 - 1. 1: Electrical Flexible Metal Conduit.
 - 2. 94: UL Standard for Safety Tests for Flammability of Plastic Materials for Parts in Devices and Appliances.
 - 3. 360: Electrical Liquid-Tight Flexible Steel.
 - 4. 514B: UL Standard for Safety Conduit, Tubing and Cable Fittings.
 - 5. 651: Schedule 40 and 80 PVC Conduit.
 - 6. 886: Electrical Outlet Boxes and Fittings for Use in Hazardous Locations, Class 1, Groups A, B, C, and D and Class 11, Groups E, F, and G.
 - 7. 1242: Intermediate Metal Conduit.
 - 8. 1684: UL Standard for Safety Reinforced Thermosetting Resin Conduit (RTRC) and Fittings.
 - 9. 6: UL Standard for Safety Electrical Rigid Metal Conduit
- E. Regulatory requirements:
 - 1. National Electrical Code (NEC): Components and installation shall comply with National Fire Protection Association (NFPA) 70.

1.04 RELATED SECTIONS

- A. General Conditions Article 4.7 – Shop Drawings and Other Submittals.
- B. Section 012901 – Measurement and Payment
- C. Section 014300 - Quality Requirements.
- D. Section 016100 - Control of Materials.
- E. Section 017700 - Contract Closeout.

F. Section 312300 – Excavation and Fill

G. Section 321710 – Asphalt Sidewalks and Driveways

1.05 SUBMITTALS

A. Submit the following items in accordance with General Conditions Article 4.7:

1. Cut sheets or other manufacture data for conduits – all types
2. Cut sheets or other manufacturer data for junction boxes
3. Cut sheets or other manufacturer data for fittings, connectors and other appurtenances
4. Hangers and conduit support systems
5. Sleeves.

B. All test reports.

1.06 QUALITY ASSURANCE

A. Comply with the requirements specified in Section 014300.

PART 2 - PRODUCTS

2.01 MATERIALS AND COMPONENTS

A. Rigid Metal Conduit(RMC):

1. Provide galvanized rigid metal conduit, each with a coupling on one end and thread protector on other end.
2. Hot-dip galvanize rigid steel conduit over entire length, along interior and exterior surfaces, including threads. Conduit shall conform to UL 6.

B. Flexible-Metal Conduit:

1. Provide flexible-metal conduit for use in dry areas and match fittings, size, and material to rigid conduit to which it is connected. Flexible-metal conduit shall conform to UL 1.
2. Provide liquid-tight flexible-metal conduit for use in damp areas consisting of flexible-metal conduit, with liquid-tight, sunlight-resistant jacket extruded over the conduit. Provide stainless steel, braided flexible conduit in NEMA 4X,

corrosive areas. On larger than 1-1/4 inch, furnish separate external ground wire. Liquid-tight flexible-metal conduit shall conform to UL 360.

C. Polyvinyl Chloride (PVC) Conduit:

1. Provide PVC conduit, Schedule 40 and Schedule 80 conforming to NEMA Standard TC-2 and UL-651.
2. Fittings and Conduit Bodies: NEMA TC 2 as recommended by the conduit manufacturer.

D. PVC Coated Rigid Metal Conduit (RMC):

1. Provide PVC coated Rigid Metal Conduit (RMC) conforming to NEMA Standard RN-1.
2. The PVC coated RMC shall be hot dip galvanized inside and out with hot dipped galvanized threads. The interior galvanizing shall be listed per UL 6. The exterior galvanizing shall be listed per UL 6 as primary corrosion protection. Thread protectors shall be used on the exposed threads of the PVC coated conduit. PVC coated ERMC- steel conduit shall comply with UL 6, ANSI C80.1, and NEMA RN-1 standards.
3. Fittings and Conduit Bodies: NEMA TC 3 as recommended by the conduit manufacturer.

E. Conduit Entry Hub for PVC Coated Rigid Metal Conduit (RMC) or RMC:

1. Provide PVC coated conduit entry hub for PVC coated Rigid Metal Conduit (RMC) conforming to NEMA Guideline FB 2.10 and UL standard 514B.
2. Provide conduit entry hub for RMC conforming to NEMA Guideline FB 2.10 and UL standard 514B.
3. Raintight type PVC coated RMC/RMC entry hub shall be provided with a separate sealing ring to be installed outside a box or enclosure to ensure a raintight interface between the fitting's body and the box.

F. Junction Boxes:

1. Junction Boxes shall be NEMA 4X, Type 316 stainless steel for outdoor exposed application, size to accommodate wiring and terminal blocks. Boxes shall be code- gauge galvanized sheet steel for non-exposed application. Size boxes to provide bending radius for wire or cable of at least eight (8) times diameter or in accordance with NEC, whichever is larger.

2. 18 inches x 36 inches Junction Box, Cast in place shall be Concrete Class B with hot dip galvanized metal cover. Construct cast-in-place junction boxes or junction box foundations. Keep forms in place for at least 24 hours after placing concrete. Neatly finish exposed portions of junction boxes with a wood float followed by brushing with a wet, soft-haired brush. Set junction box covers to grade with the surrounding area. Excavate, backfill and compact using the desired method as specified in Section 312300. Restore disturbed areas to original condition as specified in Section 321710.
3. With Construction Manager approval or shown on the Contract, fabricated 17 inches x 30 inches Composition Junction Box (Cove Park Option B only) shall be fiberglass or polymer concrete type. Excavate, backfill and compact using the desired method as specified in Section 312300. Restore disturbed areas to original condition as specified in Section 321710.

G. Fittings:

1. Provide cast-iron fittings of malleable iron or a mixture of gray iron and cast steel.
2. For PVC coated galvanized steel conduit, use this same type of material as PVC coated galvanized steel conduit and fittings supplied from the same manufacturer of conduits.
3. Provide suitable expansion fittings where conduits cross expansion joints. Equip these fittings with grounding straps, clamps, and copper bonding jumpers.

PART 3 - EXECUTION

3.01 INSTALLATION

- A. Perform all work in accordance with the NEC.
- B. Install conduits and Junction boxes as indicated, according to manufacturer's printed instructions.

3.02 INSTALLATION OF FITTINGS

- A. Install expansion fittings wherever conduits cross structural expansion joints. Keep the fittings in line with conduit, and install with regard to temperature so that full working range of expansion is available.
- B. Do not install fittings to replace elbows and pull boxes, unless space or other problems make use of fittings necessary. Use oversize fittings whenever large cable is installed, in order to maintain proper bending radius.

- C. Terminate conduits entering gasket sheet-metal boxes or gasketed sheet-metal equipment enclosures with gasketed hubs.

3.03 INSTALLATION OF CONDUITS

- A. Install exposed conduits parallel or at right angles to walls. Make all changes in directions with listed bends, elbows, and pull boxes. Space parallel runs uniformly throughout. Secure in place by hangers and fasteners. Grounding and Bonding conduits by connection to properly grounded bonding, or other means, to obtain permanent low resistance path to ground throughout installation. Ensure that conduits sections in single run and in parallel runs are of same type and finish.
- B. Terminations: Where conduits are terminated with locknuts and bushings, align the raceway to enter squarely, and install the locknuts with dished part against the box; use two (2) locknuts, one inside and one outside the box.
- C. When specified on the Contract Drawings, install conduits in slabs as close to middle of concrete slabs as practicable without disturbing reinforcement. Do not use conduit with outside diameter exceeding one-third of slab thickness. Do not place conduits closer than three (3) diameters on centers, except at cabinet locations where slab thickness is increased as permitted by Architect/Engineer.
- D. Provide cast-in-place inserts in concrete to support all runs, unless otherwise permitted. Use stainless steel sleeve type concrete anchors for installing boxes, and conduit supports. Provide Type 316 stainless steel nut, bolts, and washers, for use with concrete anchors.
- E. Where conduits are concealed in bottom gate slab, place in concrete slab and not in fill below slab. Install in middle third of the slab thickness where practical, and leave at least 4 inches of concrete cover.
- F. Run conduit larger than 1-inch trade size parallel to or at right angles to main reinforcement. When at right angles to reinforcement, place conduit close to slab support.
- G. Provide sleeves passing through exterior walls and slabs which are wall entrance seals of watertight construction. Furnish watertight seal between slab and sleeve, and between sleeve and conduit or cable.
- H. Install conduit seal such that the installation is submersible.

3.04 SLEEVE SEALS

- A. Description: Modular sealing device, designed for field assembly, to fill annular space between sleeve and raceway or cable.

- B. Manufacturers: Subject to compliance with requirements.
- C. Sealing Elements: EPDM interlocking links shaped to fit surface of cable or conduit. Include type and number required for material and size of raceway or cable.
- D. Pressure Plates: Stainless steel. Include two (2) for each sealing element.
- E. Connecting Bolts and Nuts: Stainless steel of length required to secure pressure plates to sealing elements. Include one for each sealing element.

3.05 GROUT

- A. Nonmetallic, shrinkage-resistant grout: ASTM C 1107, factory-packaged, nonmetallic aggregate grout, non-corrosive, non-staining, mixed with water to consistency suitable for application and a 30-minute working time.

3.06 SLEEVE INSTALLATION FOR ELECTRICAL PENETRATIONS

- A. Electrical penetrations occur when raceways, cables, wireways, or cable trays penetrate concrete slabs, concrete or masonry walls, or fire-rated floor and wall assemblies.
- B. Concrete slabs and walls: install sleeves for penetrations unless core-drilled holes or formed openings are used. install sleeves during erection of slabs and walls.
- C. Use pipe sleeves unless penetration arrangement requires rectangular sleeved opening.
- D. Fire-rated assemblies: install sleeves for penetrations of fire-rated floor and wall assemblies unless openings compatible with firestop system used are fabricated during construction of floor or wall.
- E. Cut sleeves to length for mounting flush with both surfaces of walls.
- F. Extend sleeves installed in floors 2 inches above finished floor level.
- G. Size pipe sleeves to provide 1/4-inch annular clear space between sleeve and raceway or cable, unless indicated otherwise.
- H. Seal space outside of sleeves with grout for penetrations of concrete and masonry. Promptly pack grout solidly between sleeve and wall so no voids remain. Tool exposed surfaces smooth; protect grout while curing.
- I. Interior penetrations of non-fire-rated walls and floors: seal annular space between sleeve and raceway or cable, using joint sealant appropriate for size, depth, and location of joint.

- J. Fire-rated-assembly penetrations: maintain indicated fire rating of walls, partitions, ceilings, and floors at raceway and cable penetrations. install sleeves and seal raceway and cable penetration sleeves with firestop materials.
- K. Clean, prime, or otherwise prepare openings as required by the firestop manufacturer.
- L. Install materials in accordance with manufacturer’s instructions, using materials, quantity of material, and installation methods proper for each penetration type. Provide accessory materials required.
- M. Inspect firestopping for proper installation, drying, curing, and adhesion as appropriate for the materials and systems being used. Make any necessary repairs and reinspect the repaired installation.
- N. Above ground, exterior-wall penetrations: seal penetrations using steel pipe sleeves and weather-tight mechanical sleeve seals. select sleeve size to allow for 1-inch annular clear space between pipe and sleeve for installing mechanical sleeve seals.
- O. Underground, exterior-wall penetrations: install cast-iron pipe sleeves. Size sleeves to allow for 1-inch annular clear space between raceway or cable and sleeve for installing mechanical sleeve seals.

3.07 SLEEVE-SEAL INSTALLATION

- A. Install to seal above-ground wall penetrations to provide a watertight seal.
- B. Use type and number of sealing elements recommended by manufacturer for raceway or cable material and size. Position raceway or cable in center of sleeve. Assemble mechanical sleeve seals and install in annular space between raceway or cable and sleeve. Tighten bolts against pressure plates that cause sealing elements to expand and make watertight seal.

3.08 FIRESTOPPING

- A. Apply firestopping to penetrations of fire-rated floor and wall assemblies for electrical installations to restore original fire-resistance rating of assembly.
 - 1. Clean, prime, or otherwise prepare openings as required by the firestop manufacturer.
 - 2. Install materials in accordance with manufacturer’s instructions, using materials, quantity of material, and installation methods proper for each penetration type. Provide accessory materials required.

3. Inspect firestopping for proper installation, drying, curing, and adhesion as appropriate for the materials and systems being used. Make any necessary repairs and reinspect the repaired installation.

3.09 BENDS

- A. Make all bends carefully to prevent distortion of circular cross section. Field bend conduit shall have an inside radius of not less than nine diameters.
- B. Where bends of less than nine (9) diameters are necessary, use standard factory elbows. Size conduit to permit cable-bending radius within the factory elbow of at least eight (8) times cable diameter.
- C. Allow no conduit greater than 50 feet to have more than two (2) 90 degree bends or equivalent thereof between pulling points. For conduits less than 50 feet (15.2 meters) in length, allow only three (3) 90 degree bends between pulling points.

3.10 CUTTING, THREADING AND CONNECTING

- A. Make all field cuts in conduits squarely, file cut ends, ream to remove rough edges and thread in accordance with NEC. No running thread permitted. Make all connections mechanically strong and tight, and with acceptable connectors. Where conduit surface coating is damaged or removed in the cutting, threading or reaming process, restore the surface to its original condition.

3.11 CONDUIT CLEANING

- A. Clean all conduits carefully before and after installation, ream ends free of burrs, and free inside surfaces from all imperfections likely to injure cable.
- B. After installation of each complete new conduit run, snake the run with band to which is attached a tube cleaner with cylindrical mandrel of a diameter not less than 85 percent of nominal diameter of conduit. Remove and replace all conduits through which mandrel will not pass.
- C. Use a sponge with steel brush to clean steel conduit and use a sponge with nylon brush to clean PVC conduits.
- D. After cleaning, protect ends of all conduits with standard caps to prevent entrance of water, concrete, debris, or other foreign substance.

3.12 CONDUIT DRAINAGE

- A. Where practicable, pitch conduit to drain to outlet boxes, or install so as to avoid trapping moisture. Where dips are unavoidable in exposed conduits, install fitting with drain hole at low point.

3.13 CONDUIT BACKFILLING FOR EARTH INSTALLATION

- A. Ensure that conduit is centered in the trench and is held firmly in place while the trench is backfilled. Excavate, backfill and compact using the desired method as specified in Section 312300. Restore disturbed areas to original condition as specified in Section 321710 or as directed by Construction Manager.

3.14 CONDUIT BACKFILLING FOR ROADWAY INSTALLATION

- A. Excavate the trench, place and maintain the conduit in the center of the trench and fill the trench using the desired method as specified in Section 312300. Replace the existing pavement structure in kind, the conditions as specified in Section 321710 or as directed by Construction Manager.

3.15 INSTALLATION OF JUNCTION BOXES

- A. Install boxes in conformance with all the requirements of NEC. Install boxes designed for type of construction involved. Support boxes in same manner as required for conduit.

3.16 FLEXIBLE CONNECTIONS TO MOTORS

- A. At all motors and electrically operated equipment to which conduit connections are made, install with a complete connection between end of conduit and terminal box of motor or other equipment. Length of flexible connection shall be no more than 3 feet.
- B. Install the conduits in locations permitting direct connection to motors.
- C. Make connections between rigid conduits and motor or equipment subject to vibration and adjustment using flexible conduit. Make each connection with at least one (1) quarter bend so that no vibration can be transmitted beyond flexible connection.
- D. Install flexible metal conduit, fittings, and accessories in dry areas in accordance with requirements of NEC.
- E. Install liquid-tight flexible metal conduit in damp and corrosive areas. Locate conduit to reduce the possibility of damage to the exterior coating. Use fittings that screw into flexible conduit and provide gaskets.

3.17 CONTRACT CLOSEOUT

- A. Provide in accordance with Section 017700.

END OF SECTION 260533

SECTION 262000 - ELECTRIC WINCH MOTORS

PART 1 - GENERAL

1.01 DESCRIPTION

- A. This Section apply to low voltage electric winch motors and accessories, furnished under other Sections, and which are a part of equipment assemblies shall be in conformance with the requirements specified in this Section, unless otherwise noted. This Section includes performance, and descriptive type specifications.
- B. Unless otherwise specified or approved, all electric motors furnished and installed by the Contractor and shall conform to the requirements specified herein.
- C. Motors rated 1 hp or greater shall be premium efficient type per NEMA MG-1.

1.02 PAYMENT

- A. No separate payment shall be made for performing any Work required under this Section. All costs for Work required by this Section shall be included in the applicable lump sum, unit price(s), or allowance(s) as set forth in Section 012901.

1.03 REFERENCES

- A. The American society of Mechanical Engineers (ASME).
 - 1. Winches- ASME B30.7.
- B. Institute of Electrical and Electronics Engineers (IEEE).
 - 1. 112: Test Procedures for Polyphase Induction Motors and Generators.
- C. National Electric Manufacturer's Association (NEMA):
 - 1. MG-1: Motors and Generators.
- D. National Fire Protection Association (NFPA):
 - 1. 70: National Electrical Code (NEC).

1.04 RELATED SECTIONS

- A. General Conditions Article 4.7 – Shop Drawings and Other Submittals
- B. Section 012901 – Measurement and Payment

- C. Section 014300 - Quality Requirements
- D. Section 016100 – Control of Materials
- E. Section 017823 – Operation and Maintenance

1.05 SUBMITTALS

- A. Submit shop drawings and manufacturers' product data in accordance with General Conditions Article 4.7 – Shop Drawings and Other Submittals.
- B. Descriptive literature and motor characteristics.
 - 1. Shop drawings and descriptive data to include:
 - a. Complete list of all motors to be furnished.
 - b. Outlines, dimensions, weights, and wiring diagrams.
 - c. Location of main and accessories boxes with size of conduit entrance.
 - d. Efficiency and power factor at 1/2, 3/4, and full load.
 - e. Bearing design data and grease requirements.
 - f. Nameplate data.
 - g. Shop test report.
 - h. Field acceptance test report.
 - i. Strip heaters KW and voltage ratings.
 - j. Built in overload protection device.
 - C. Submit an Operations and Maintenance Manual as per Section 017823.

1.06 QUALITY ASSURANCE

- A. Comply with the requirements specified in Section 014300.
- B. Motors to comply with the latest reference standards listed below.
 - 1. National Electrical Code (NEC).
 - 2. Underwriters Laboratories Inc. (UL).
 - 3. National Electric Manufacturer's Association (NEMA).

- a. NEMA Standard MG-1 - Motors and Generators.
 4. Anti-Friction Bearing Manufacturer's Association, Inc. (AFBMA).
 5. American National Standard Institute (ANSI).
 6. Institute of Electrical and Electronics Engineers (IEEE).
 - a. IEEE Standard 112 - Test Procedures for Polyphase Induction Motors and Generators.
 - C. Routine tests shall be performed on representative motors, and shall include the information described on NEMA MG1-12.54 Report of Test Form for Routine Tests on Induction Motors. Efficiency shall be determined in accordance with IEEE Publication No. 112, Method B. Power factor shall be measured on representative motors.
- 1.07 DELIVERY, STORAGE AND HANDLING
- A. Comply with the requirements in Section 016100.
 - B. Ship motors assembled to driven equipment complete except where partial disassembly is required by transportation regulations or for protection of components.
 - C. Pack spare parts in containers bearing labels clearly designating contents and pieces of equipment for which intended.
 - D. Deliver spare parts at same time as pertaining materials. Deliver to the Construction Manager after completion of work.
 - E. Receiving and Storage:
 1. Inspect and inventory items upon delivery to site.
 2. Store and safeguard equipment and material in heated storage facility as recommended by equipment manufacturer. Protect motors from moisture at all times.

PART 2 - PRODUCTS

2.01 ELECTRIC MOTOR RATINGS

- A. Voltage Ratings:
 1. Motor shall be rated at 240VAC (nameplate rating), three-phase, 60-Hertz.

2.02 MOTOR DESIGN REQUIREMENTS

- A. Winch motors shall be designed and constructed to meet the stresses imposed on their frames and components under all anticipated condition when properly installed and when handling loads not exceeding the winch motors ratings.
- B. Motor heaters shall be supplied on all motors installed outdoors or in unheated areas. Heaters shall be of the cartridge or flexible wrap around type installed within the motor enclosure adjacent to core iron. Heaters shall be rated for 120-volt, single phase with wattage as required. The heater wattage and voltage shall be embossed on the motor nameplate.

2.03 ELECTRIC MOTOR RATING

- A. Every motor shall be of sufficient capacity to operate the driven rolling gate and operating conditions without exceeding its rated nameplate current or power or its specified temperature limit at rated voltage. Each motor shall develop ample torque for its required service throughout its acceleration range at a voltage 10 percent below nameplate. The rated motor shall not be required to deliver more than its rated nameplate horsepower, at unity (1.0) service factor. Motor nameplates shall be stainless steel.
- B. Type of Motors:
 - 1. Winch motors shall be NEMA Design D with very high locked rotor torque.
- C. Motor Insulation:
 - 1. Winch motors shall have Class F insulation in accordance with NEMA Standards for Motors and Generators, NEMA MG1, and based on a maximum ambient temperature of 40 degrees C, unless otherwise specified.
 - 2. Motors for outdoor service shall have vacuum/pressure impregnated epoxy insulation for moisture resistance.
- D. Motor Enclosures:
 - 1. Motors shall have a steel or cast-iron frame and a cast iron or stamped steel conduit box with NEMA 4X.
 - a. Totally enclosed fan cooled: TEFC motors shall have a steel or cast-iron frame, cast iron end brackets and cast-iron conduit box.
- E. Auxiliary Devices:
 - 1. Motors shall have built-in overload protection device.

F. General Design of Motors:

1. Motors shall comply with the latest NEMA Standards Publication No. MG1 for Motors and Generators, unless otherwise specified.
2. Motor windings shall be braced to withstand successfully the stresses resulting from the method of starting. The windings shall be treated thoroughly with acceptable insulating compound suitable for protection against moisture and slightly acid or alkaline conditions.
3. Bearings shall be of the self-lubricating type, designed to ensure proper alignment of rotor and shaft and to prevent leakage of lubricant.
 - a. Bearing minimum L-10 fatigue life in hours at 100 percent load shall be 50,000.
 - b. Bearing grease shall be of the 120 degrees C thermal capability type.
4. All three phase motors shall be provided with a 1.15 service factor.
5. Winch motors shall be of cast iron construction including frame and end brackets.
6. Totally enclosed motors shall be provided with automatic breather and drain.
7. Motor nameplates shall be stainless steel.
8. Motor Terminal Boxes and Leads:
 - a. Motors shall be furnished with oversize terminal boxes to provide for making and housing the connections, and with flexible leads of sufficient length to extend for a distance of not less than 4 inches beyond the face of the box. The size of cable terminals and terminal box conduit hoses shall be as permitted by the Construction Manager. An acceptable type of solderless lug to be furnished. Totally enclosed and explosion-proof motors to have cast-iron terminal boxes.
 - b. Sealed cable entry shall be provided to prevent water entering the box.
 - c. Leads for space heaters shall be brought out into an auxiliary, cast, conduit box on the motor side opposite to the main terminal box. Auxiliary box to have 1 inch threaded conduit openings and shall be so constructed that conduit entrance may be placed at top, bottom, or either side.
 - d. A grounding terminal shall be provided in the main terminal box and a bronze grounding bolt to be furnished at the conduit side of the motor frame.

G. Motor Efficiencies:

1. Winch motors efficiency shall be rated as per NEMA MG1. Efficiency values shall be based on tests performed in accordance with IEEE Publication No. 112, Method B. Motors with horsepower or rpm's not listed shall conform to comparable standards of construction and materials as those for listed motors.

H. Shop Painting:

1. Unless otherwise specified, motors shall be given a shop application of paint filler or enamel sealer, a flat coat of undercoater for enamel, and two coats of enamel or, in lieu of this treatment, other corrosion-resistant treatment customary with the manufacturer.

I. Motor Data:

1. The Contractor shall furnish the Construction Manager with five (5) certified copies of characteristic curves of each motor furnished, except 115-volt motors. Curves shall be supplied as a part of the driven equipment submittal.

J. Motor Shop Tests:

1. Motor shop tests shall be made in accordance with the IEEE Test Codes as specified in the NEMA MG1 Standards for Motors and Generators. NEMA report-of-test forms to be used in submitting test data.
2. Motor efficiency shall be determined by use of IEEE Standard 112 Test Method B, and by use of MGI-12.53 a and b.

PART 3 - EXECUTION

3.01 INSTALLATION

- A. Verify heaters are energized on motors installed in outdoor or unheated areas.
- B. After motor installation, but before connection to power wiring, test motor winding insulation in accordance with the applicable Division 26 requirements.
- C. After connection to power wiring, check for operating temperature, correct rotation, vibration, alignment and operating current drawn under load.
- D. Submit all motor test results for review and record.

END OF SECTION 262000

SECTION 262416 - PANELBOARDS

PART 1 - GENERAL

1.01 DESCRIPTION

- A. Provide the following inside the panelboard:
 - 1. Manual transfer switch.
 - 2. Main circuit breaker.
 - 3. Distribution panel rated 240-3PH VAC, 60Hz shall be furnished with breakers for winch motor control panels and spare breakers.
 - 4. Distribution panel rated 120-1PH VAC, 60Hz shall be furnished with breakers for lighting circuits, 120V NEMA type 5-15R duplex receptacle and spare breakers.
 - 5. Dry-type step down transformer 240V-1PH/ 120-1PH
 - 6. Enclosure wall mounted receptacle NEMA type L15 for mobile generator. The generator receptacle shall be mounted on the side of the panelboard that has adequate work clearance per NEC.

1.02 PAYMENT

- A. No separate payment shall be made for performing any Work required under this Section. All costs for Work required by this Section shall be included in the applicable lump sum, unit price(s), or allowance(s) as set forth in Section 012901.

1.03 RELATED SECTIONS

- A. General Conditions Article 4.7 – Shop Drawings and Other Submittals
- B. General Conditions Article 4.10 – Testing
- C. Section 012901 – Measurement and Payment
- D. Section 014300 – Quality Requirements
- E. Section 017700 – Contract Closeout
- F. Section 260526 - Grounding and Bonding for Electrical Systems

1.04 REFERENCES

- A. Federal Specifications (FS):
 - 1. W-P-115C: Panel, Power Distribution.
- B. National Electrical Manufacturers Association (NEMA):
 - 1. 250: Enclosures for Electrical Equipment (1000 volts maximum).
 - 2. AB 1: Molded Case Circuit Breakers.
 - 3. PB 1: Panelboards.
 - 4. ST 20: Dry-Type Transformers for General Applications
- C. National Fire Protection Association (NFPA):
 - 1. 70: National Electrical Code (NEC).
- D. Underwriter's Laboratories, Inc. (UL):
 - 1. 50: Cabinets and Boxes.
 - 2. 67: Panelboards.
 - 3. 86A: Wire Connectors and Soldering Lugs for Use with Copper Conductors.
 - 4. 1561: Dry-Type General Purpose and Power Transformers

1.05 SUBMITTALS

- A. Submit shop drawings and manufacturers' product data in accordance with General Conditions Article 4.7.
- B. Submit manufacturer's certificates for proof that all materials comply with specified requirements.
- C. Submit manufacturer's certified destructive test reports completed by an accredited independent testing laboratory, indicating compliance with any specified factor or safety.
- D. Submit an Operations and Maintenance Manual as per Section 017823.

1.06 QUALITY ASSURANCE

- A. Refer to General Conditions Article 4.10

- B. Refer to Section 014300
- C. All panelboards shall be designed, manufactured, and assembled in accordance with the referenced standards.
- D. Listing and Labeling: All panelboards shall be listed and labeled by Underwriter's Laboratories, Inc. (UL) or other nationally recognized testing laboratory (NRTL).
- E. Service entrance panelboards shall be UL/NRTL-labeled as suitable for that purpose.

PART 2 - PRODUCTS

2.01 PANELBOARD

- A. Provide panelboard with front accessibility and front connected equipment to meet space requirements.
- B. Furnish panelboards complete with main circuit breaker, manual transfer switch, electrical distribution panels, mobile generator receptacle.
- C. Copper Ground Bar: Standard bolted.

2.02 PANELBOARD ENCLOSURE

- A. Panelboard enclosures shall be pad-mountable free-standing, NEMA 4X, Type 316, vandal-resistant stainless steel with padlockable door.

2.03 MAIN CIRCUIT BREAKERS

- A. Main 240 VAC 3 pole three phase circuit breaker shall be bolted into position in the panelboard, whether by direct bolted connection to the bus or by being bolted to the panelboard frame.
- B. Main 240 VAC 3 pole three phase circuit breaker shall be service entrance rated.

2.04 ELECTRICAL PANEL

- A. Provide 240-3PH VAC, 3 wire distribution panel including branch circuit breakers.
- B. Provide 120-1PH, 2 wire VAC distribution panel including branch circuit breakers. Circuit breakers must be single pole.
- C. Finish cabinet fronts and surface-mounted boxes in ANSI No. 61 or 49, light-gray enamel over a rust-inhibitive primer.
- D. Copper Ground Bar: Standard bolted.

- E. Provide panel with the voltage, frequency, current ratings of main, ampere ratings of branches, as indicated conforming to NEMA Standard PB1, Federal Specification W-P-115A. U.L. 67, and the NEC.

2.05 STEP-DOWN TRANSFORMER

- A. Provide single phase dry type step-down transformer, suitable for general purpose, lighting and power.
- B. Transformer shall have primary voltage 240V, single phase and secondary voltage 120V, single phase, 60Hz. Exact power rating to be determined at detailed engineering stage. Size of the transformer shall include 15 percent spare capacity.
- C. Insulation Class: 180 deg C, UL-component-recognized insulation system with a maximum of 115 degrees C maximum average temperature rise when transformer operated at full nameplate rating in 40 degrees C maximum ambient temperature.
- D. Enclosure type: NEMA 1.
- E. Enclosure material: Steel.
- F. Winding material: Copper
- G. Core and coil to be encapsulated within resin compound, sealing out moisture and air. Transformer shall be wall mountable.

2.06 DISCONNECT SWITCH

- A. Provide non-fusible disconnect switch with ampere rating and number of poles as required at the detailed engineering stage. Switch shall be heavy-duty Type HD. Provide switch in NEMA Type 4X enclosure. Mechanism shall have quick-make and quick-break operating handle and provisions for padlocking in the "OFF" position. The switch shall have an interlock to prevent unauthorized opening of the hinged cover when the switch is in the "ON" position and an interlock to prevent closing the switch mechanism with the hinged cover open. On the front of the enclosure, attach a nameplate that identifies the load. Manufacturers shall be Eaton Cutler-Hammer, Square D Company, Siemens AG, or equal.
- B. Disconnect switch for the electrical panelboard shall be suitable for service entrance application.
- C. Heavy duty safety switches to be UL listed, File E 2875 and 154828, and meet or exceed NEMA Standard KS1.

2.07 FACTORY TESTING

- A. Standard factory tests shall be performed on the equipment provided under this Section. All tests shall be in accordance with the latest version of NEMA and UL standards.

PART 3 - EXECUTION

3.01 INSTALLATION

- A. Mount panelboards without distortion of the box. Mount such that the height of the top switches or handles do not exceed 6 feet 7 inches from the ground.
- B. Panelboard shall be mounted on a concrete pedestal or concrete wall. Exact location shall be coordinated with the Construction Manager.
- C. Hang each door of the cabinet on semi- or fully-concealed hinges with a combination catch and lock.
- D. On cabinets 48 inch high and over, install a 3-point catch assembly latching at top, bottom, and approximate middle.
- E. Verify all panelboard locks are keyed alike.
- F. Provide typed directory card filled-out to clearly indicate the load served.
- G. Door hinge to be on the side opposite escape route, if applicable.
- H. Ground equipment according to Section 260526.

3.02 CONTRACT CLOSEOUT

- A. Provide in accordance with Section 017700.

END OF SECTION 262416

NO TEXT ON THIS PAGE

SECTION 262717 – WINCH CONTROL PANEL AND PENDANT PANEL

PART 1 - GENERAL

1.01 DESCRIPTION

- A. This Section describes materials and installation of custom winch control panels and pendant panel.

1.02 PAYMENT

- A. No separate payment shall be made for performing any Work required under this Section. All costs for Work required by this Section shall be included in the applicable lump sum(s), as set forth in Section 012901.

1.03 REFERENCES

- A. Underwriters' Laboratories, Inc., (UL):
 - 1. 486A: UL Standard for Safety Wire Connectors and Soldering Lugs for Use with Copper Conductors.
 - 2. 508: Electrical Industrial Control Equipment.
 - 3. 508A: Industrial Control Panels.
 - 4. 1059: Safety Terminal Blocks.
- B. National Electrical Manufacturers Association (NEMA):
 - 1. 250: Enclosures for Electrical Equipment (1000 volts maximum).

1.04 RELATED SECTIONS

- A. General Conditions Article 4.7 – Shop Drawings and Other Submittals
- B. Section 012901 – Measurement and Payment
- C. Section 017700 – Contract Closeout
- D. Section 017823 – Operation and Maintenance Manual
- E. Section 353130 – Rolling Gates and Appurtenances

1.05 SUBMITTALS

- A. Submit shop drawings and manufacturers' product data in accordance with General Conditions Article 4.7.
- B. Submit a complete list of equipment, materials, and any details required to demonstrate that the equipment will function properly as a unit. This material shall include:
 - 1. Detailed descriptions of equipment including weights, dimensions, and installation requirements.
 - 2. Internal panel layouts indicating spacing and dimensions.
 - 3. Panel front layouts.
 - 4. Catalog cuts of devices used.
 - 5. Control schematics and interconnection drawings.
 - 6. Nameplates.
- C. Submit an Operations and Maintenance Manual as per Section 017823.

PART 2 - PRODUCTS

2.01 OVER CURRENT PROTECTION RELAY

- A. Manufacturer shall provide over current relay protection which be quickly shut down the motor power supply in case of over current. Adjustment of relay reaction time shall be based on motor startup current characteristics.

2.02 SOFT-STARTER FOR MOTOR

- A. Motors greater than 3hp shall be protected by a motor soft-starter to limit current in-rush seen by the portable generator when connected to backup power.
- B. Reduced voltage solid-state starter shall be compact and multifunctional with a built-in overload protection and built-in run bypass contactor. It shall be suitable for mounting in the enclosure type specified for a control cabinet. Starter shall be capable of controlling the acceleration and deceleration of the motor it will serve to soft-start and soft-stop the motor. After the motor is started, internal run bypass contactors shall close, resulting in the motor running directly across-the-line. The built-in solid-state overload shall protect the motor from overload conditions with adequate algorithms that shall model true motor heating, resulting in better motor protection and fewer nuisance trips. Starter shall have selectable voltage ramp start or current limit start (adjustable from 0 percent to 550 percent FLA, 5 to 180 seconds adjustment time) and kick-start (adjustable from 0 percent

to 85 percent initial torque, 0.5 to 180 seconds) capabilities. The soft-stop (adjustable from 0 to 60 seconds) mode shall allow for a ramp stop time that shall be longer than the coast to stop time. The starter shall use SCRs to control the motor.

- C. The starter shall be rated for 3-phase 1.15 service factor motors and be suitable for a three-lead configuration.
- D. Starter shall be rated for 25-second ramp time, four starts per hour, 200 percent starting current limit at 40 degrees C ambient or 15-second ramp time, four starts per hour, 200 percent starting current at 50 degrees C ambient. The starter shall have selectable protective features with variable settings allowing the user to fine-tune the starter to meet specific system requirements.
- E. Protection shall include:
 - 1. Stall: Trip to protect the system in the event that the motor did not achieve the rated speed in the defined soft-start period.
 - 2. Pole Overtemperature: Overtemperature protection shall occur if the device's thermal capacity is exceeded. The solid-state starter shall trip in overtemperature conditions, preventing device failure. The device pole temperature value shall be monitored through the digital interface module or the communications network.
 - 3. Phase Loss: Trip at three seconds on phase loss.
 - 4. Phase Current and Voltage Imbalance: Adjustable.
 - 5. Phase reversal.
 - 6. Shorted SCR detection.
- F. Reset Mode: It shall be possible to set up for manual reset on trip. The manual reset shall be achieved by means of a reset button located on the starter. It shall also be possible to reset the overload manually. Starter shall have the following dry contacts:
 - 1. Up-to-Speed (Run): Normally open, closes when motor reaches full speed.
 - 2. Fail or Fault: Normally open, closes when an internal fault is detected. If starter has only a closed contact that opens when an internal fault is detected, an interposing relay shall be added to reverse the signal.
- G. Standards and Certifications: Starter shall be UL listed.
- H. Manufacturers: Equipment shall be Schneider ATS or later model, Allen-Bradley SMC-3 or later model, Siemens AG model, or equal.

2.03 INDUCTIVE PROXIMITY SWITCH

- A. The gate movement can be controlled by inductive proximity switches. The proximity switch casing shall be built in stainless steel and the proximity switch shall be rated NEMA 6P for reliable performance.

2.04 STEP-DOWN TRANSFORMER

- A. 240 VAC/115VAC Step down transformer shall be provided to supply power for the pendant and proximity switch.

2.05 ENCLOSURE

- A. Control panel enclosures shall be NEMA 4X heavy-duty, vandal-resistant stainless steel with padlockable door.

2.06 OPERATOR SUBMERSIBLE PENDANT

- A. Submersible pendant shall be designed for winch motor application requiring single speed button. The enclosure shall be made from rugged, double insulated thermoplastic material.
- B. Submersible pendant push buttons shall be designed for NEMA 6P.
- C. Submersible pendant panel must be installed on the exterior side of the Resist Structure beside the control panel and shall be NEMA 6P stainless steel with padlockable door.
- D. Push buttons shall be standard size, round, with hold contact types.
- E. Provide heavy duty pushbuttons, Siemens AG, Schneider Electric, EATON Electric, or approved equal. Pushbuttons shall be hold type. Indicating lights to be LED cluster type.
- F. One (1) operator pendant shall be provided for each winch's motor with the following function push buttons:
 1. 'SPOOL OUT': The winches' pendant shall be provided with 'SPOOL OUT' push button to allow the wire rope to reach the shackle gate.
 2. 'SPOOL IN': The winches' pendant shall be provided with 'SPOOL IN' push button; the opening or closing of the gate shall continue until a fully open or close position is reached.
 3. Emergency stop button: Cut off any power to the motor.
 4. The "fully open" or "fully closed" position is indicated with a pilot light installed on the operator pendant.
 5. For more details, refer to the Contract Drawings.

2.07 CONTROL WIRING

- A. 120-volt control wiring shall be Type MTW, THWN, or THHN. Conductors shall not be smaller than No. 14 AWG. Ampacity shall be in accordance with the NEC.
- B. Instrumentation signal cables shall be of the type used for field wiring.

2.08 MARKING

- A. Identify wire terminations with a number to correspond with the schematic diagrams. Identification tags shall be preprinted white heat-shrinkable tubing, Raychem Thermofit TMS or equal.

2.09 CONTROL DEVICES

- A. Provide 240VAC/115VAC step down transformer. Provide 15 percent volt-ampere spare capacity that is in addition to the loads specified. Fuse one (1) side of secondary winding and ground other side. Provide primary winding fuses on both lines.
- B. Provide indicator lights and push buttons for status and manual control.
- C. Control relays shall be magnetically held and shall have convertible contacts. Control relays shall be UL listed with NEMA rated contacts and coil voltage, number of poles, and pole arrangement as indicated in the Contract Drawings. All relays shall be of the same manufacturer. Relays shall be Allen-Bradley Bulletin 700, Westinghouse Type AR, IDEC RH Series, Schneider Electric AG, or equal.

2.10 TERMINAL BLOCKS

- A. Provide terminal blocks for incoming and outgoing control wires. Wire and mount terminal blocks so that internal and external wiring do not cross over the terminals. Do not terminate more than two (2) conductors at each terminal connection.
- B. Field wiring shall terminate on the "field side" of the terminal blocks. Do not connect internal panel wiring to the "field side" of the terminal blocks. Do not connect field wiring to the "panel side" of the terminal blocks.
- C. Terminal blocks shall be modular, rail mounted, capable of terminating wire sizes No. 12 through No. 24 AWG and constructed of polyamide thermoplastic. Terminal blocks shall be UL listed in accordance with UL 486A and UL 1059. Current-carrying parts shall be copper, or brass electroplated with tin/lead. Terminal connection shall be a screw clamp pressure plate connection, designed such that the clamping screw does not clamp the screw directly to the wire.
- D. Provide symmetrical steel assembly rails, end brackets, jumper bars, and other accessories as required for a complete terminal block assembly.

- E. Consecutively number terminal blocks from top to bottom with preprinted marking tags. Tags shall be white polyamide and hot printed with black symbols so that the print is permanent.

PART 3 - EXECUTION

3.01 FIELD TESTS

- A. Test control panel with field wiring connected. Set adjustable set points and time delays for proper operation of equipment. Check operation of control panel and field devices to verify correct operation. Perform required adjustments for correct operation. Gate manufacturer shall provide a checklist to verify correct operation, engineer shall accept the checklist prior to field test.
- B. Refer to Section 353130, Section 3.05 Commissioning, for test procedure of rolling gate controlled by the winch control panel and pendant panel.

3.02 CONTRACT CLOSEOUT

- A. Provide in accordance with Section 017700.

END OF SECTION 262717

SECTION 263213 - PORTABLE GENERATOR

PART 1 - GENERAL

1.01 DESCRIPTION

- A. Provide gasoline portable generator set complete with components, to be coordinated with the Gate component electrical requirements.
- B. The power rating shall be compatible with the equipment served, the portable generator shall be three-phase, 60-Hertz, 240VAC, four-wire, alternating current.
- C. The generator shall be sized to account for the load of one (1) motor operating at one time, not two (2) motors operating simultaneously and emergency lighting load and 15 percent spare capacity.

1.02 PAYMENT

- A. No separate payment shall be made for performing any Work required under this Section. All costs for Work required by this Section shall be included in the applicable lump sum(s), as set forth in Section 012901.

1.03 REFERENCES

- A. National Electrical Manufacturers Association (NEMA):
 - 1. AB 1: Molded-Case Circuit Breakers, Molded Case Switches, and Circuit-Breaker Enclosures.
 - 2. ICS 2: Standard for Industrial Control and Systems: Controllers, Contractors, and Overload Relays Rated Not More than 2000 Volts AC or 750 Volts DC: Part 8 - Disconnect Devices for Use in Industrial Control Equipment.
 - 3. ICS 6: Standard for Industrial Controls and System Enclosures.
 - 4. MG 1: Standard for Motors and Generators.
 - 5. PB 1: Standard for Panelboards.
 - 6. SG 6: Standard for Power Switching Equipment.
 - 7. MW36-C: Magnet wire.
- B. National Fire Protection Association (NFPA):
 - 1. 30: Flammable and Combustible Liquids Code.

2. 37: Installation and Use of Stationary Combustion Engines and Gas Turbines.
 3. 70: National Electrical Code (NEC).
 4. 110: Standard for Emergency and Standby Power Systems.
- C. Society of Automotive Engineers International (SAE):
1. ARP892: DC Starter-Generator, Engine.
 2. J537: Storage Batteries
- D. Underwriters Laboratories (UL):
1. 142: Steel Aboveground Tanks for Flammable and Combustible Liquids.
 2. 489: Standard for Molded-Case Circuit Breakers, Molded-Case Switches and Circuit-Breaker Enclosures.
 3. 1446: Systems of Insulations Materials.
- E. Institute of Electrical and Electronics Engineers (IEEE):
1. General Principles for Temperature Limits in the Rating of Electric Equipment and for the Evaluation of Electrical Insulation.
- 1.04 RELATED SECTIONS
- A. General Conditions Article 4.7 – Shop Drawings and Other Submittals
 - B. Section 012901 – Measurement and Payment
 - C. Section 017823 – Operation and Maintenance Manual
- 1.05 SUBMITTALS
- A. Submit the following in accordance with General Conditions Article 4.7.
 1. Generator Set
 2. Plug connector
 - B. Submit an Operations and Maintenance Manual as per Section 017823.

PART 2 - PRODUCTS

2.01 GENERATOR COMPONENTS

- A. One (1) twist lock receptacle NEMA type L15 suitable for 240VAC, 3 phase, 4 wire connection. The exact amperage of the receptacle shall be confirmed based on the portable generator rating chosen at detailed design stage.
- B. Minimum two (2) 125V, 15A 1ph, NEMA 5-15R receptacles, type ground fault circuit interrupter (GFCI) shall be provided as convenience receptacles. In the event of a ground fault a GFCI trips automatically to stop the flow of electricity and prevent serious injury.
- B. Ground Terminal: the grounding terminal shall be provided.
- C. Circuit Breaker: Portable generator shall be equipped with circuit breaker to protect against electrical overloads.
- D. Hour Meter: shall be provided to indicate the hours of use.
- E. Voltmeter: shall be provided to indicate the voltage output of generator.
- F. Extension Cords: Extension cord length shall be at least 100 feet with NEMA type L15 plug and receptacle matching the amperage of the generator output. It shall be spooled and stored with the generator when not in use.
- G. Batteries for electric start
- H. Control Panels: Two-position engine control switch with following features shall be provided:
 - 1. Stop/Reset: In this position, the engine shall not be capable of starting and/or running. If the engine was shut down due to the operation of a protective device, the shutdown malfunction shall be reset when the switch is moved to this position. If the engine is running when the switch is moved to this position, it shall be immediately shutdown.
 - 2. Manual starting switch

2.02 ENGINE SPECIFICATIONS

- A. The gasoline engine shall be commercial duty rating for extended operation.
- B. Equipped with oil warming light.
- C. Auto voltage regulation with voltmeter

- D. Should be design for easy maintenance.
- E. Should meet ANSI regulations for Outdoor Powered Equipment.
- F. Electric start

2.03 PORTABLE GENERATOR DATA SHEET

POWER PHASES	THREE PHASES
FREQUENCY	60 HZ
AC OUTPUT	240 3PH VAC
MAXIMUM (STANDBY) OUTPUT	
MAIN CIRCUIT BREAKER	YES
ALTERNATOR TYPE	BRUSHLESS
GFCI OUTLETS	YES
FUEL TYPE	GASOLINE
START TYPE	ELECTRIC
COOLING	AIR
FUEL TANK CAPACITY	
RPM	3600
DECIBEL RATING	
RUN TIME	

PART 3 - EXECUTION

3.01 INSTALLATION

- A. Fill the tank with gasoline as recommended by manufacturer. After field testing is complete, refill the tank.

- B. The entire unit shall be completely installed, wired, and plumbed by the engine supplier prior to shipment to the service site.

3.02 START-UP

- A. On completion of the installation, the City Operator shall thoroughly inspect, operate, test, and adjust the equipment. The inspection shall include the soundness of all parts, completeness of all details, proper operation of all components with special emphasis on safety devices and correctness of settings.
- B. Field tests shall include the following:
 - 1. Simulate power failure by tripping the main breaker and demonstrate complete manual start, load, unload, and stop sequence of the portable generator.
 - 2. Conduct a two-hour run, utilizing maximum available load. If available load is less than 75 percent of the generator's rating, then add loads to obtain 75 percent generator loading (minimum). The generator supplier shall provide load banks and make necessary connections to provide the required 75 percent load.
 - 3. Operate gate motor on generator power to demonstrate generator shut down functions.
- C. A written operational report including start-up inspection and field tests, signed by the manufacturer's representative, shall be submitted to the DEP prior to acceptance.

END OF SECTION 263213

NO TEXT ON THIS PAGE

SECTION 263613 - NON-AUTOMATIC (MANUAL) TRANSFER SWITCHES

PART 1 - GENERAL

1.01 DESCRIPTION

- A. This Section specifies the requirements for the design, fabrication, assembly, wiring, testing, delivery, and installation of low voltage (240-3PH/120-1PH volt) non-automatic transfer switches. Each non-automatic transfer switch unit shall consist of a mechanically held power transfer switch and a manual handle.

1.02 PAYMENT

- A. No separate payment shall be made for performing any Work required under this Section. All costs for Work required by this Section shall be included in the applicable lump sum, or allowance(s), as set forth in Section 012901.

1.03 REFERENCES

- A. National Fire Protection Association (NFPA):
 - 1. 70: National Electrical Code (NEC).
- B. National Electrical Manufacturers Association (NEMA):
 - 1. ICS10: AC Automatic Transfer Switch Equipment Underwriters Laboratories.
- C. (UL):
 - 1. 1008: Transfer Switches. (Manual Transfer Switches).

1.04 RELATED SECTIONS

- A. General Conditions Article 4.7 – Shop Drawings and Other Submittals
- B. General Conditions Article 4.10 - Testing
- C. General Conditions Article 8.2 – Operations, Equipment and Manuals
- D. Section 012901 – Measurement and Payment
- E. Section 017700 – Contract Closeout

1.05 SUBMITTALS

- A. Submit shop drawings and manufacturers' product data in accordance with General Conditions Article 4.7.
- B. Submit manufacturer's descriptive data including ratings, circuit diagrams, dimensional data, conduit entry restrictions, and a list of accessories.

1.06 OPERATION AND MAINTENANCE MANUALS

- A. Operation and maintenance manuals shall be submitted.

PART 2 - PRODUCTS

2.01 TRANSFER SWITCH

- A. Transfer switch shall be installed inside a pad-mountable free-standing NEMA 4X enclosure (panelboard), mounted on the wall of the panelboard enclosure.
- B. The non-automatic transfer switches shall transfer load in delayed transition (break-before-make) mode. Transfer shall be accomplished with a user-defined interruption period in both directions, as specified herein. The load disconnect time delay shall be configured to be active for all transfers or to be bypassed in the event that the voltage of all three phases of the source the load is connected to drop below 70 percent of nominal.
- C. The non-automatic transfer switches shall be rated for continuous duty based on all load classes (inductive motors, resistive loads, electric discharge lamps, and tungsten lamps).
- D. Non-automatic transfer switches shall be 4-pole and suitable for application to 3-phase, 4-wire, 60 Hz, 240-3PH volt systems.
- E. At a minimum, transfer switches shall be 3-cycle rated in accordance with UL Standard 1008. Minimum UL 3-cycle close-on and withstand ratings at 240 VAC with any molded case circuit breaker (MCCB) matching with the non-automatic transfer switches size.

2.02 CONSTRUCTION

- A. The transfer switches unit shall be electrically operated and mechanically held. The electrical operators shall be dual-solenoid or dual-motor mechanisms, momentarily energized. The normal and emergency contacts shall be positively interlocked mechanically and electrically to prevent simultaneous closing.
- B. The transfer switches unit shall be positively locked and unaffected by momentary outages so that contact pressure is maintained at a constant value and temperature rise at the contacts is minimized for maximum reliability and operating life.

- C. All main contacts shall be silver alloy composition designed to resist burning or pitting. Separate arcing contacts designed for rapid and reliable arc quenching and equipped with magnetic blowouts shall be provided.
- D. Inspection of all contacts shall be possible from the front of the transfer switches without disassembly of operating linkages and without disconnection of power conductors. A manual operating handle shall be provided for maintenance purposes. The handle shall permit the operator to manually stop the contacts at any point throughout their entire travel to inspect and service the contacts when required.
- E. Designs utilizing components which are not intended for continuous duty, repetitive switching or transfer between two active power sources are not acceptable. Insulated case and molded-case circuit breaker type switches are not acceptable.
- F. Control components and wiring shall be front accessible without disassembly of operating linkages and with disconnection of power conductors. All control wiring shall be identified with tubular sleeve-type markers.
- G. Each transfer switches shall be mounted and wired at the factory, including mounting and wiring of all door-mounted accessories.

2.03 ADDITIONAL FEATURES

- A. LED indicating lights shall be provided; one to indicate when the transfer switches is connected to the normal source (green) and one to indicate when the transfer switches is connected to the emergency source (red).

PART 3 – EXECUTION

3.01 INSTALLATION

- A. Install transfer switch in panelboard. Secure transfer switch rigidly to panelboard wall.

3.01 FIELD TESTING:

- B. Field test per manufacturer's recommended standard test procedure.

3.02 CONTRACT CLOSEOUT

- A. Provide in accordance with Section 017700.

END OF SECTION 263613

NO TEXT ON THIS PAGE

SECTION 265619 - LED LIGHTING

PART 1 - GENERAL

1.01 DESCRIPTION

- A. Furnishing and installing LED lighting system and other power distribution equipment. The system includes but not limited to providing Light Emitting Diode (LED) lighting fixtures, lighting standards, bases and a meter cabinet, junction boxes, lighting and 24 hour service distribution panel including disconnect switches with breakers, enclosure for housing irrigation control panel, event box and power supply with enclosures for housing LED strip, puck and in-grade lighting, white color LED strip lighting fixture, prewired string of white LED pucks lighting fixture and white LED in-grade lighting fixture , cables and wiring as indicated and in compliance with Contract Documents.
- B. These Specification Sections are to be considered supplementary to the information contained in the Contract Documents. In areas of conflict the Contract Documents will supersede these Specifications Sections.
- C. LED lighting fixtures shall include:
 - 1. LED Flood lighting units
 - 2. LED Area lighting units
 - 3. LED Wall mounted lighting units
 - 4. LED Strip lighting units
 - 5. LED String of prewired puck lighting units
 - 6. LED In-grade lighting units
- D. Power Distribution equipment shall include:
 - 1. Meter Cabinet
 - 7. Lighting Distribution Panel
 - 8. Irrigation, event box and other 24-hour Service Panel
 - 9. Disconnect Switches – disconnect switches with circuit breakers
 - 10. Power Supply and Enclosures for LED strip, puck and in-grade lighting fixtures

11. Enclosure for irrigation control panel

E. Lighting Standards shall include:

1. Lighting Standards, bases, grounding, wire and wiring.

1.02 PAYMENT

A. No separate payment shall be made for performing any work required under this Section. All costs for work required by this Section shall be included in the applicable lump sum(s) as set forth in Section 012901.

1.03 REFERENCES

A. American Association of State Highway and Transportation Officials (AASHTO):

1. LTS-3: Standard Specifications for Structural Supports for Highway Signs, LED luminaires and Traffic Signals

B. American National Standards Institute (ANSI)

C. ASTM International (ASTM):

1. B209/B209M: Standard Specification for Aluminum and Aluminum-Alloy Sheet and Plate

2. B429/B429M: Standard Specification for Aluminum-Alloy Extruded Structural Pipe and Tube

D. European Standards (ENs):

1. UNE-EN 40-5:2002: Standard Specifications for Lighting Columns-Part 5, Requirements for Steel Lighting Columns

E. UL Standards:

1. cULus approved

2. Confirms to UL 2108 Low Voltage Lighting Systems

1.04 RELATED SECTIONS

A. General Conditions Article 4.7 – Shop Drawings and Other Submittals

B. General Conditions Article 4.10 – Testing

- C. Section 012901 – Measurement and Payment
- D. Section 014300 - Quality Requirements
- E. Section 016100 - Control of Materials
- F. Section 017700 - Contract Closeout
- G. Section 260519 – Wires and Cables Less than 600V

1.05 SUBMITTALS

- A. Submit the following shop drawings in accordance with General Conditions Article 4.7.
 - 1. Submit shop drawings and manufacturer's product data, brochures including layout and wiring diagrams in accordance with this Section.
 - 2. Submit IES data file for each LED luminaire, LED strip lighting fixture, LED puck lighting fixture and LED in-grade lighting unit.
 - 3. Shop drawings to include all hardware and mountings.
 - 4. Maintenance manuals and wiring diagrams.
- B. Submit an Operations and Maintenance Manual as per Section 017823.

1.06 QUALITY ASSURANCE

- A. Comply with the requirements specified in Section 014300.
- B. Standard Products: Material and equipment shall be the latest standard products of a single manufacturer regularly engaged in the manufacture of the product for 5 years as a minimum or as specified.

1.07 DELIVERY, STORAGE AND HANDLING

- A. Comply with the requirements specified in Section 016610.
- B. Equipment placed into storage shall be protected from the weather, humidity and temperature variations, dirt, dust, and other contaminants and maintained in original factory appearance. Any damaged lighting standards, LED luminaires, meter cabinet, power distribution panels, enclosures, power supplies, PS enclosures, LED strip lighting fixture fixtures, LED string puck lighting fixtures and LED in-grade lighting fixture shall be repaired as exactly same as brand new or replaced by the same types within the Contract schedule. Install the listed equipment and fixtures by methods that prevent scratching, bending, twisting or abrasion per manufacturer's handling instructions.

PART 2 - PRODUCTS

2.01 MATERIALS AND COMPONENTS

A. LED Floodlight Type FL-A.

1. The LED luminaire shall have a heavy-duty, die cast aluminum housing, driver compartment and driver door, a separate driver compartment and external fins to provide optimal thermal management that result in longer LED and driver life.
2. The LED luminaire is to be UL/cULus listed for wet locations and is IP66 rated. It shall have a 3G vibration rating (ANSI C136.31).
3. The four LED chambers shall utilize a vacuum metalized reflector that provides high-efficiency illumination. Optics are to be precisely designed to shape the NEMA type 6H x 6V wide distribution, to maximize efficiency and application spacing.
4. A clear glass tempered lens with full circumference form-in-place silicone gasket shall be provided to protect the optics from damage.
5. A NEMA twist lock photocontrol receptacle and photoelectric control shall be provided on each LED luminaire. A shorting cap shall be provided.
6. The LED driver is mounted to the removable die-cast aluminum door for optimal heat sinking and ease of maintenance.
7. The fixture shall require no more than 316 watts. And operate on voltages 120-277V 50/60Hz and have a 6kV/10kA mode surge protector.
8. The LED luminaire shall provide 90 percent lumen maintenance greater than 50,000 hours per IESNA TM-21. The unit shall have a CCT of 5000K.
9. The housing and cast parts finished in five-stage super TGIC polyester powder coat paint.
10. The LED luminaire shall be mounted on an integral die-cast aluminum slipfitter that is preset to a tilt of 45 degrees. The knuckle base is required with a tooth lock adjustment that can be adjusted in 5 degrees increments. Visual 15 degrees adjustment indicators on the knuckle shall allow for 180 degrees field rotation of the floodlight assembly. The slipfitter fits standard 2-3/8 inches-3 inches O.D. tenon.
11. The LED luminaire shall be aimed as indicated on the Contract Documents or as directed by the Construction Manager.

12. The LED luminaire shall have a ten-year warranty.

B. LED Floodlight Type FL-B.

1. The LED luminaire shall have a heavy-duty, die cast aluminum housing, driver compartment and driver door. A separate driver compartment and external fins to provide optimal thermal management that result in longer LED and driver life.
2. The LED luminaire is to be UL/cULus listed for wet locations and is IP66 rated. It shall have a 3G vibration rating (ANSI C136.31).
3. The two LED chambers shall utilize a vacuum metalized reflector that provides high-efficiency illumination. Optics are to be precisely designed to shape the NEMA type 6H x 6V wide distribution, to maximize efficiency and application spacing.
4. A clear glass tempered lens with full circumference form-in-place silicone gasket shall be provided to protect the optics from damage.
5. A NEMA twist lock photocontrol receptacle and photoelectric control shall be provided on each LED luminaire. A shorting cap shall be provided.
6. The LED driver is mounted to the removable die-cast aluminum door for optimal heat sinking and ease of maintenance.
7. The fixture shall require no more than 185 watts. And operate on voltages 120-277V 50/60Hz and have a 6kV/10kA mode surge protector.
8. The LED luminaire shall provide 90 degrees lumen maintenance greater than 50,000 hours per IESNA TM-21. The unit shall have a CCT of 5000K.
9. The housing and cast parts finished in five-stage super TGIC polyester powder coat paint.
10. The LED luminaire shall be mounted on an integral die-cast aluminum slipfitter that is preset to a tilt of 45 degrees. The knuckle base is required with a tooth lock adjustment that can be adjusted in 5 degrees increments. Visual 15 degrees adjustment indicators on the knuckle shall allow for 180° field rotation of the floodlight assembly. The slipfitter fits standard 2-3/8 inches-3 inches O.D. tenon.
11. The LED luminaire shall be aimed as directed by the Construction Manager.
12. The LED luminaire shall have a ten-year warranty.

C. LED Area Light Type LP-A, LP-B/C/D & LP-G

1. The LED luminaire shall have a heavy-duty, die cast aluminum housing, driver compartment and driver door. A separate driver compartment and external fins to provide optimal thermal management that result in longer LED and driver life.
2. The LED luminaire is to be UL/cULus listed for wet locations and is ISO 9001 rated. It shall have a 3G vibration rating (ANSI C136.31) and LM79/LM80 compliant.
3. The LED luminaire shall utilize two to twelve light bars to shape the optics distribution. The fixture shall provide an IES Type III distribution at 4000K CCT. The Type A LED luminaire shall be provided with 5 light bars to produce a minimum of 15,084 lumens with a BUG Rating of B2-UO-G3. The bars will be composed of 105 LEDs.
4. The fixture shall require no more than 127 watts (LP-A), 75 watts (LP-B/C/D) and 96 watts (LP-G). And operate on voltages 120-277V 50/60Hz and have a 10kV/10kA common and differential mode surge protector.
5. A NEMA twist lock photocontrol receptacle and photoelectric control shall be provided on each LED luminaire.
6. The photoelectric control units shall be outdoor type, single pole-single throw, 105-277VAC, 50/60 hertz, and shall be rated for a minimum of 1800 Volt-Ampere and 5000 on-off operations. Operating levels shall be 1 + 0.2 FC (nominal) for turn-on and 3 FC (average) for turn-off conditions. Average power consumption of the unit shall be less than 1.6 Watts. The unit shall be rated for ambient temperature range of -65°F to + 158°F and shall be moisture resistant for 100% relative humidity. Chassis of the units shall be molded phenolic with three twist lock type blades and removable neoprene gasket, all in conformance with NEMA standards. The photoelectric control units shall be equipped with encapsulated surge protection devices and hermetically sealed photocell, and shall be furnished with receptacle units and necessary mounting devices.
7. The LED luminaire shall provide 95 percent lumen maintenance greater than 60,000 hours per IESNA TM-21. The unit shall have a CCT of 4000K.
8. The housing and cast parts finished in five-stage super TGIC polyester powder coat paint.
9. The LED luminaire shall be mounted on a mast arm that is 1-1/4 inches to 2 inches horizontal tenon or a cast aluminum 6 inches arm depending on the project plans requirements.
10. The maximum weight shall not exceed 35 lbs. with an EPA of 1.20 sq. ft.

11. The LED luminaire shall have a five-year warranty.

D. LED Wall Mounted Light Type WP-A

1. The LED luminaire shall have a heavy-duty, one-piece die cast aluminum housing and a hinged, removable die cast aluminum door. The Optical chamber shall be sealed with a one-piece silicone gasket.
2. The LED luminaire is to be UL 1598 wet location listed and IP66 ingress protection rated.
3. The LED driver and related components shall be mounted to the housing for heat sinking. The removable door shall be fitted with a borosilicate glass and a wire guard.
4. All hardware shall be stainless steel and taper resistant. The fixture shall produce a minimum of 5,880 lumens with a BUG Rating of B1-U3-G4.
5. The fixture shall require no more than 46watts. And operate on voltages 120-277V 50/60Hz and withstand a 6kV.
6. The LED luminaire shall provide 90 percent lumen maintenance greater than 72,000 hours of operation. The unit shall have a CCT of 5000K.
7. The housing and cast parts finished in five-stage super TGIC polyester powder coat paint.
8. The LED luminaire be provided with a photoelectric control.
9. The LED luminaire shall have a five-year warranty.

E. Led Floodlight Type for Series L1 – L7 Lighting Poles

1. The LED luminaire shall have a heavy-duty, die cast aluminum housing, driver compartment and driver door, a separate driver compartment and external cooling fins to provide optimal thermal management that result in longer LED and driver life.
2. The housing/ chassis is to be NEMA 4X rated protection for outdoor installation.
3. The optics is to be combined optical system made in high performance PMMA, resistant to high temperature and UV radiation.
4. The diffuser is to be in tempered glass, 0.16 inch thick, resistant to thermal shocks and impact.

5. A NEMA Type 4 and 4N7 twist lock photocontrol receptacle and a shorting cap shall be provided on each LED luminaire.
6. The LED driver is to be mounted to the removable die-cast aluminum door for optimal heat sinking and ease of maintenance.
7. The fixture shall require no more than 35 watts per fixture and operates on voltages 120-277V 50/60Hz and have a 1/2kA mode surge protector.
8. The LED luminaire shall provide a minimum of 3293 lumens. It shall provide 80 percent lumen maintenance greater than 90,000 hours per IESNA TM-21. The unit shall have a CCT of 4000K.
9. The housing and cast parts are to be coated with standard polyester power coating for UV, corrosion and salt resistant.
10. The LED luminaire shall be aimed as required by the Contract Documents or as directed by the Construction Manager.
11. The LED luminaire shall have a ten-year warranty.
12. Number of projectors for manufacturer's series shall be per lighting standards as shown on the Contract Documents.
13. The Lighting Standard Type shall be complied with followings or equal:
 - a. Install lighting standard including the foundation, grounding of all materials and internal cable and wiring. Install the lighting standard foundation and lighting standard as required by the Contract Documents.
 - b. Lighting standard material shall made from galvanized steel and painted with metallic silver.
 - c. Foundation: Shall be constructed as detailed on the Contract Documents.

F. Led Area Light for Cove Park Option A

1. The LED luminaire shall have a heavy-duty, die cast aluminum end caps with an extruded aluminum driver enclosure. Die-cast aluminum heat sinks that are interlocking with housing. A removable LED driver tray assembly for ease of maintenance. The circuitry shall be designed to withstand 10kV of transient line surge. The luminaire Suitable for operation in -40 degrees C to 40 degrees C ambient environments. Optional 50 degrees C high ambient (HA) configuration.
2. The optics shall use high-efficiency injection-molded AccuLED Optics technology.

3. The LED luminaire is to be UL/cULus listed for wet locations and is ISO 9001 rated. It shall have a 3G vibration rating (ANSI C136.31) and LM79/LM80 compliant.
4. The LED luminaire shall be capable of utilize two to ten light squares to shape the optics distribution. The fixture shall provide with two light squares to provide an IES Type IV Wide distribution at 4000K CCT. The Cove Park Option A LED luminaire (CPO2 Luminaire) shall produce a minimum of 9,460 lumens with a BUG Rating of B2-UO-G2. The squares will be composed of 16 LEDs.
5. The fixture shall require no more than 77 watts and operate on voltages 120-277V 50/60Hz and have a 10kV/10kA common and differential mode surge protector.
6. A NEMA twist lock photocontrol receptacle and photoelectric control shall be provided on each LED luminaire with a shorting cap.
7. The LED luminaire shall provide 95 percent lumen maintenance greater than 60,000 hours per IESNA TM-21. The unit shall have a CCT of 4000K and provide a minimum of 143 lumens per watt.
8. The housing and cast parts finished in five-stage super TGIC polyester powder coat black paint.
9. The LED luminaire shall be mounted on an arm that is a quick mount 10-5/8 inches long.
10. The maximum weight shall not exceed 35 lbs. with an EPA of 1.11 sq. ft.
11. The LED luminaire shall have a five-year warranty.

G. LED Area Light for Cove Park Option B

1. The LED luminaire shall have a heavy-duty, die cast aluminum with an aluminum driver enclosure. Die-cast aluminum heat sinks will be provided. The circuitry shall be designed to withstand 10kV of transient line surge. The luminaire Suitable for operation in -40 degrees C to 40 degrees C ambient environments. Optional 50 degrees C high ambient (HA) configuration.
2. The LED luminaire is to be UL/cUL listed for wet locations and is ISO 9001 rated. It shall have a 3G vibration rating (ANSI C136.31) and LM79/LM80 compliant.
3. The fixture shall require no more than 35 watts and operate on voltages 120-277V 50/60Hz and have a 10kV/10kA common and differential mode surge protector.
4. The LED luminaire shall provide 95 percent lumen maintenance greater than 60,000 hours per IESNA TM-21. The unit shall have a CCT of 4000K.

5. The fixture shall conform to the lighting standard manufacturer's recommendation for the system. When installed on the standard the fixture shall provide adjustment to the rotation and pitch of the fixture.

H. LED Strip Lighting Fixture

1. The LED strip lighting fixture shall have white color changing output flexible spools, highly durable, outdoor rated and impact resistant.
2. The LED strip lighting fixture is to be UL/cUL listed for wet locations. It shall have an NEMA 6P Ingress Protection against intrusion, dust, accidental contact and water.
3. The maximum fixture run per spool shall be 32.8 feet.
4. The LED strip lighting fixture shall require no more than 123 watts per 32.8 feet spool. The LED strip fixture shall operate on 24VDC supplied power through an associated 300W power supply or equal. Dimmable switch isn't required.
5. The housing/chassis is to be Aluminum, NEMA 4X Damp location or suitable for outdoor application and protected by enclosure.
6. The power supply shall be operable ambient temperature from -31 deg. F to +158 deg. F or equal.
7. The power supply operates on voltages 100-277V 50/60Hz and have a 10kV/10kA common and differential mode surge protector or equal. It shall have capable to drive minimum two (2) LED strip lighting fixture, 30.8 feet, white single-color spools. Power supply compartment shall have external fins to provide optimal thermal management that result in longer power supply life.
8. The power supply shall be compatible with LED strip lighting fixture fixtures and drive minimum two (2) spools of 32.8 feet or equal.
9. The LED strip lighting fixture shall provide at least 70 percent lumen maintenance greater than 50,000 hours per IESNA L70.
10. The lumens per foot shall be within the range of 120 based on 4000K single color.
11. The fixture connectors and cable shall be 9.84 feet injection molded feed cable included with end cap or using water-tight power connector as shown on the Contract Documents.
12. Locking mounting channel shall be aluminum and the lengths shall be 1.37 inches, 3.28 feet or 6.56 feet or equal.

13. The maximum weight shall not exceed 7.6 lbs. per 32.8 feet spool.
14. The LED strip lighting fixture fixtures shall be installed on guardrail, planters or mounted under enclosure arranged on flood wall as required on the Contract Documents and manufacturer’s instruction. The item includes all manufacturer supplied parts to complete the installation, grounding and wiring.
15. Each circuit shall be protected by fuse/circuit breaker within the power supply enclosure.
16. The LED strip lighting fixture fixtures shall have a five-year warranty.
17. The size of power feed wires from the power supply enclosure to LED strip lighting fixture fixtures shall be sized per the distance shown on the table below.

(Table 2)

FIXTURE TYPE	18 AWG	14 AWG	12 AWG
LED Strip Lighting (SC)	40 feet	100 feet	180 feet

I. LED String of Pucks Lighting Fixture

1. The prewired string of single-color LED pucks lighting fixture shall have white single color changing output flexible spools, highly durable and outdoor rated.
2. The fixture is to confirm to UL 2108 Low Voltage Lighting Systems. It shall have an NEMA 4X or above Ingress Protection against intrusion, dust, accidental contact and water.
3. The maximum fixture run per prewired string of LED pucks lighting fixture powered from 96W power supply shall be 60 feet with the total number of pucks (132) or equal.
4. The prewired string of LED pucks fixture shall require no more than 96 watts per the maximum total fixture length shown on the above Table 2 or equal. The LED strip fixture shall operate on 24VDC supplied power through an associated 96W power supply or equal. Dimmable switch is not required. Input voltage of power supply shall have a range of 120-277VAC, 50/60Hz or equal.
5. The housing/chassis is to be NEMA 4X Damp location or suitable for outdoor application and protected by enclosure.

6. The power supply shall be operable ambient temperature from -13 deg. F to +104 deg. F or equal.
7. The prewired string of LED pucks lighting fixture shall provide at least 70 percent lumen maintenance greater than 50,000 hours per IESNA L70. The lumens of pucks shall be 4500K single color.
8. The prewired string of LED pucks lighting fixture shall provide consistent and uniform illumination.
9. The prewired string of LED pucks lighting fixture shall be installed within weather protected enclosure mounted under structure beam of pedestrian walkway bridge as required in the plans and manufacturer’s instruction guideline. The item includes all manufacturer supplied parts to complete the installation, grounding and wiring.
10. Each circuit shall be protected by fuse/circuit breaker within power supply enclosure.
11. The electrical power wires shall be terminated on the fixture end using water-tight power connector as shown on the Contract Documents (landscape and architecture details).
12. The LED pucks lighting fixture shall have a five-year warranty.
13. The size of power feed wires from the power supply enclosure to LED strip lighting fixture fixtures shall be sized per the distance shown on the table below.

(Table 4)

FIXTURE TYPE	18 AWG	14 AWG	12 AWG
LED Puck Lighting (SC)	20 feet	50 feet	90 feet

J. LED in-Grade Lighting Fixture and Led Power Supply

1. The LED in-grade lighting fixture shall be pre-wired with 10 inches lengths of #12 AWG wires and waterproof cable gland entry with seal into housing.
2. The fixture and housing shall be stainless steel and NEMA 6P rated or equal.
3. 0.6W LED, 24V DC rated lamp shall be provided.
4. 24V DC class 2 power supply within NEMA 6P stainless steel enclosure shall be provided.

5. The LED modules shall be shall have 50,000 hours and/or twenty-year warranty.
6. The LED in-grade lighting fixture shall provide at least 70 percent lumen maintenance greater than 50,000 hours per IESNA L70. The lumens of pucks shall be 4000K white single color.

K. Power Supply Enclosure

1. The LED power supply (PS) enclosure shall Enclosure shall be minimum 12 inches (H) x 12 inches (W) x 8 inches (D), 316 Stainless Steel and NEMA 4X for resist wall and Urban Amenity LED strip lighting. For Cove Park, it shall be minimum 12 inches (H) x 6 inches (W) x 6 inches (D), 316 Stainless Steel/Powder coated and NEMA 3R and within the soffit of the pedestrian bridge. It shall be wall mount type, foamed-in place gasket protection, left-hand hinged pad lockable door. It shall be supplied with a back panel, wall mounting brackets (4), print pocket, grounding straps and accessories. Any power supply enclosures if it is installed on in-ground per the Contract Documents shall be NEMA 6P submersible enclosure.
2. Maximum two (2) power supplies shall be mounted within the enclosure on the locations for resist wall and Urban Amenity LED strip lighting as indicated on the Contract Documents.
3. Each circuit for LED strip lighting fixture or prewired string of white LED pucks lighting fixture shall be protected by fuse/circuit breaker within the power supply enclosure.
4. Provide grounding terminal and bond enclosure and hubs to earth ground on metal part of pedestrian bridge or copper clad ground rod (3/4 inches Dia. x 10 feet Long) of in-ground installation.
5. Conduit entries shall be through water-tight Crouse-Hinds, Eaton Electric PLC, Schneider Electric, or approved equal.
6. PS enclosure locations not defined on the contract plan shall be installed near the location of LED strip lighting fixture as well as behind of public view as much as possible for preventing vandalization. It shall be mounted on proper foundation and support for preventing it from storm water damages.
7. Proper stainless-steel material shall be used for mounting PS enclosure. Liquid-tight galvanized steel flexible conduit shall be used within 6 feet of termination to enclosure or LED strip lighting fixture/prewired string of white LED pucks lighting fixture.

L. Meter Cabinet Type R, G & G2

1. Install cabinets, meters, control and distribution systems, including the grounding of all materials, and internal wire and wiring. Install the metering systems as required by the Utility.
2. The ampacity for the service wire, main breaker and site wiring will be provided at detailed engineering stage by contractor. Refer to “Single Line Diagram Operating System For Rolling Gate”

M. Power Distribution Equipment

1. Install disconnect switches with breakers, power distribution cabinets, meters, contactor, control and distribution systems, including the grounding of all materials, and internal wire and wiring on location shown on the wiring diagram and the Contract Documents. Install the metering systems as required by the Utility.
2. The ampacity for the service wire and site wiring will be provided at detailed engineering stage by the Contractor. Refer to the Contract Documents and “Wiring Diagram”.

2.02 MANUFACTURERS:

A. Lighting Luminaires

1. Eaton Streetworks Company
2. General Electric Company
3. Holophane

B. LED Flexible Strip Lighting Fixtures

1. Acclaim Lighting
2. LED Neon Strip Light
3. LED Flex

C. LED String of Puck Lighting Fixtures

1. 3form
2. LEDELS Lighting
3. GE LED Signage Lighting systems

D. LED in-grade Lighting Fixtures

1. BEGA
2. XDESIGN LED
3. Flairlight BV

E. Lighting Standards on Cove Park

1. Escofet FUL Series

PART 3 - EXECUTION

3.01 INSTALLATION

A. LED Flood Light

1. Install the lighting system as indicated on the Contract Documents, in accordance with the manufacturer's diagrams, specifications and printed instructions, except where otherwise indicated.
2. Leave the factory installed wrapping on the LED Flood lighting luminaires for as long as the manufacturer recommends. Install the LED Flood lighting luminaires with the wrapping in place and maintain the LED Flood lighting luminaires and other material in original factory appearance and use methods that prevent scratching, excessive bending, twisting or abrasion. Prior to Final Acceptance, replace any damaged material at the Contractor's own expenses.
3. Bolt the standard securely to the foundation and erect the standard with enough rake to assume a vertical position after all attachments and appurtenances are in place. For aluminum standards, the Contractor may install leveling shims to a maximum height of 1/4 inch. Provide and install the standard with ground studs either in the base for aluminum or in the standard for steel. Install a ground wire that extends to the ground rod from the standard.
4. Install the arm as indicated on the plans and attach to the standard. When mounting the arm and other materials, use methods that prevent scratching or abrasions. Repair abrasions and scratches. Provide modifications or adjustments that may be required for final aiming of all lighting fixtures.
5. Attach the LED luminaire plumb to the end of the arm or on the pole. Ensure proper and accurate aiming of flood lights.
6. Provide and install cable connectors (fused and nonfused), and two (2) No. 10 AWG color-coded, multiple-lighting wires extending from the driver terminals to

the distribution wires in the base of the pole or in the adjacent junction box for lighting pole LED luminaires.

7. Tag fixture wire by identifying the meter cabinet, circuit, and LED luminaire fixture number.
8. Use color-coded, single-conductor, multiple-lighting wire with plastic, colored tape overlapped from duct edge to duct edge within each junction box for lighting circuits. Clearly identify neutral (white) and ground (green) circuits with continuous color compound along their entire lengths within the junction box. Pull conductors through conduit and junction boxes to allow racking and connection to LED luminaire and meter cabinet. Seal the underground conduit entrance to meter cabinets or transformer enclosures with a sealing compound.
9. Identify the circuit number of conductors by attaching plastic cable identification tags to each conductor in all junction boxes and at the meter cabinets of the load centers with 1-inch-high letters. Secure tags to the conductor using nylon cable ties.
10. Install cable and wire in the conduit system. Pull cable and wire through junction boxes to allow racking and connection to cabinets, poles, mast arms, and other Items.
11. When pulling wires and cables through conduit, do not overstress or stretch, and take precautions not to score, twist, or damage the protective covering or insulation. Ensure wire lubricant is used or an industry approved wire pulling machine. Except for ground wire, provide all wires and cables in junction boxes, pull boxes and enclosures with adequate slack placed on the cable racks. For cable splices in boxes, use a Type C copper pressure connector, and mechanically and electrically secure splices with the proper tool. Clean the conductors with a minimum of insulation removed.
12. Identify the circuit number of the cables and wires by attaching cable identification tags with 1 inches high letters to each of the cables or wires in all junction boxes and in the cabinets of the load centers or controller. Secure tags to the cable or wire using nylon cable ties.
13. For multiple-lighting wire splices, use a resin splicing kit as follows:
14. Use an in-line type splicing kit for joining a single conductor to another to form 1 continuous through conductor.
15. Use a tap or wye-type splicing kit where it is necessary to obtain a tap connection at a through conductor or where it is necessary to join more than two conductors.

16. Keep the conductors and splicing connector centered within the mold, so an even amount of resin surrounds the splice.
17. Bond and ground electrical circuits, metallic conduit, junction boxes, junction box foundations, above-ground material, and all other materials as well as seal for preventing moisture penetration as specified in the NEC and as required by the Utility.
18. Ensure bare ground wire is used when installing a bonding wire in junction boxes. Secure it to the conduit bushings and to the ground rod.
19. Secure the ground wire to all ground rods and all materials requiring grounding.
20. For the LED lighting systems, use either an insulated or bare ground wire.
21. If fastening electrical boxes to masonry with expansion fasteners, provide fasteners of enough size and strength to provide adequate support. Use stainless steel mounting bolts and anchors. If not using a boss, secure conduit entering electrical boxes to the box using lock nuts on the inside and outside of the box.

B. LED strip lighting fixture and puck lighting fixtures

1. Install the LED strip and puck lighting fixtures (prewired string of LED lighting pucks) as well as power supply lighting system as indicated on the Contract Documents, in accordance with the manufacturer's diagrams, specifications and printed instructions, except where otherwise indicated.
2. Leave the factory installed wrapping on the LED strip lighting fixture and puck lighting fixtures as well as power supply for as long as the manufacturer recommends. Install the LED strip lighting fixture and puck lighting fixtures as well as power supply with the wrapping in place and maintain the LED strip lighting fixture and puck lighting fixtures and other material in original factory appearance and use methods that prevent scratching, excessive bending, twisting or abrasion. Prior to Final Acceptance, replace any damaged material at the Contractor's own expenses.
3. Install LED strip lighting fixture fixtures using the same manufacturer provided components (self-locking mounting channels, feed cable kit and end cap kit flexible/seamless link kit) per locations shown on the Contract Documents as well as manufacturer's instruction. The maximum overall length for linked single LED strip lighting fixture is 32.8 feet. Install LED puck lighting fixture is mounted on the pedestrian bridge only as shown on the Contract Documents. The maximum overall length for prewired string of LED pucks lighting fixture is 44 feet-66 feet depend on the density of LED pucks. Power supplies shall be installed within the enclosure per the locations shown on the Contract Documents.

4. Provide and install cable connectors including strip side injection feeds, fuses and two (2) No. 18 AWG lighting cables extending from the PS enclosure to the LED strip lighting fixture in the mounting channel under the rectangular steel box on top of concrete flood wall, guard rail and handrail of pedestrian bridge, benches on the planters or any other location shown on the Contract Documents. The same requirement is for prewired string of LED pucks.
5. Label and tag fixture wire by identifying the power supply enclosures, fuses, circuit and LED strip lighting fixture and puck fixtures number.
6. Use color-coded, single-conductor, multiple-lighting wire with plastic, colored tape overlapped from duct edge to duct edge within each junction box for LED strip lighting fixture and puck circuits. For 120 VAC circuit, clearly identify neutral (white) and ground (green) circuits with continuous color compound along their entire lengths within the junction box and power supply enclosure. Pull conductors through conduit, junction boxes and power supply enclosure to allow racking and connection to LED strip and puck lighting fixtures and panelboard cabinet. Seal the underground conduit entrance to panelboard cabinet or power supply enclosures with a sealing compound.
7. Identify the circuit number of conductors by attaching cable identification tags with 1 inch high letters to each conductor in all junction boxes, PS enclosures, panelboards and at the meter cabinets of the load centers. Secure tags to the conductor using nylon cable ties.
8. Install cable in the conduit system. Pull cable through junction boxes and PS enclosures to allow connection to enclosures, cabinets, LED strip lighting fixture and puck fixtures and other Items.
9. When pulling cables through conduit, do not overstress or stretch, and take precautions not to score, twist, or damage the protective covering or insulation. Ensure cable lubricant is used or an industry approved wire pulling machine. Except for ground cable, provide all cables in junction boxes, pull boxes and enclosures with adequate slack placed on the cable racks. For cable splices in boxes, use a Type C copper pressure connector, and mechanically and electrically secure splices with the proper tool. Clean the conductors with a minimum of insulation removed.
10. Identify the circuit number of the cables by attaching cable identification tags to each of the cables in all junction boxes, enclosure and in the cabinets of the load centers or PS enclosure. Secure tags to the cable using nylon cable ties.
11. For lighting cable splices, use a resin splicing kit as follows:

- a. Use an in-line type splicing kit for joining a single conductor to another to form 1 continuous through conductor.
12. Bond and ground electrical circuits, metallic conduit, junction boxes, junction box foundations, above-ground material including PS enclosures, rectangular metal boxes on top of concrete flood wall and all other materials as specified in the NEC.
13. Ensure bare ground cable is used when installing a bonding cable in junction boxes, PS enclosures, rectangular metal boxes on top of concrete flood wall. Secure it to the conduit bushings and to the ground rod.
14. Secure the ground cable to all ground rods and all materials requiring grounding.
15. For the LED strip lighting fixture and puck lighting fixture systems, use either an insulated or bare ground cable.
16. If fastening electrical boxes to masonry with expansion fasteners, provide fasteners of sufficient size and strength to provide adequate support. Use stainless steel mounting bolts and anchors. Secure conduit entering electrical boxes to the box using boss/hub.

C. LED In-grade Lighting fixture and Power supply

1. Install the LED in-grade lighting fixture and power supply lighting system as indicated on the Contract Documents, in accordance with the manufacturer's diagrams, specifications and printed instructions, except where otherwise indicated.
2. The fixture shall not be installed in low point of concrete or earth locations where it is going to be submerged underwater for an extended period.
3. The fixture shall not be installed in low point of concrete or earth locations where it is going to be submerged underwater for an extended period.
4. The fixture housing shall be firmly mounted on a proper foundation. The top edge of the fixture housing must be flush to the prepared floor.
5. A level surface shall be provided.
6. Leave the factory installed wrapping on the LED in-grade lighting fixture and power supply for as long as the manufacturer recommends. Install the LED in-grade lighting fixtures and power supplies with the wrapping in place and maintain the LED lighting fixtures, power supplies and other material in original factory appearance and use methods that prevent scratching, excessive bending, twisting or abrasion. Prior to Final Acceptance, replace any damaged material at the Contractor's own expenses.

7. Install LED in-grade lighting fixture and power supply using the same manufacturer provided components per locations shown on the Contract Documents as well as manufacturer's instruction. Power supplies shall be installed within the enclosure per the locations shown on the Contract Documents.
8. Provide and install cable connectors, fuses and two (2) No. 14 AWG lighting cables extending from the PS enclosure to each LED in-grade fixture per the location shown on the Contract Documents.
9. Label and tag fixture wire by identifying the power supply enclosures, fuses, circuit and LED In-grade fixtures number.
10. Use color-coded, single-conductor, multiple-lighting wire with plastic, colored tape overlapped from duct edge to duct edge within each junction box for LED in-grade lighting fixture circuits. For 120 VAC circuit, clearly identify neutral (white) and ground (green) circuits with continuous color compound along their entire lengths within the junction box and power supply enclosure. Pull conductors through conduit, junction boxes and power supply enclosure to allow racking and connection to LED in-grade lighting fixtures and panelboard cabinet. Seal the underground conduit entrance to panelboard cabinet or power supply enclosures with a sealing compound.
11. Identify the circuit number of conductors by attaching cable identification tags with 1-inch-high letters to each conductor in all junction boxes, PS enclosures, panelboards and at the meter cabinets of the load centers. Secure tags to the conductor using nylon cable ties.
12. For lighting cable splices, use a resin splicing kit as follows:
 - a. Use an in-line type splicing kit for joining a single conductor to another to form 1 continuous through conductor.
13. Bond and ground electrical circuits, metallic conduit, junction boxes, junction box foundations, above-ground material including PS enclosures and all other materials as specified in the NEC.
14. Ensure bare ground cable is used when installing a bonding cable in junction boxes, PS enclosures. Secure it to the conduit bushings and to the ground rod.
15. Secure the ground cable to all ground rods and all materials requiring grounding.
16. For the LED in-grade lighting fixture systems, use either an insulated or bare ground cable.

17. If fastening electrical boxes to masonry with expansion fasteners, provide fasteners of sufficient size and strength to provide adequate support. Use stainless steel mounting bolts and anchors. Secure conduit entering electrical boxes to the box using boss/hub.

3.02 FIELD TESTING

- A. After completing the wiring for each electrical system and before making connections, perform the following tests on each circuit using suitable equipment:
 1. Tests for continuity.
 2. Tests for ground.
 3. Tests for insulation resistance between circuit wires and from circuit wires to ground. Verify that the insulation resistance is at least 150 megaohms between conductors, or between conductor and ground for circuits with a total single conductor length of 1,500 feet or more, and at least 175 megaohms for circuits with a total single conductor length of less than 1,500 feet.
 4. Complete the electrical system, including connections, and repeat continuity, ground, and insulation resistance testing starting from the control cabinet. Record the observed readings with its respective circuits. Submit four copies of the wiring test results to the Construction Manager. Record on the test results the Project title, the date of the test, and the atmospheric conditions.
 5. Energize each electrical system for a minimum of 10 consecutive periods of normal operation.
 6. Replace defective material discovered during testing and retest as required. Provide written reports of all tests performed including all corrective actions that had to be performed.

3.03 CONNECTION AND COORDINATION WITH UTILITY SERVICES

- A. Install underground conduit and electrical conductors that extend from a meter cabinet or junction box to a point on the service pole or manhole and supply an enough length of conductors to extend to the overhead utility service as required by the Utility and subject to its approval. Ensure the Utility completes the extensions of the conductors from this point on the pole and connections to overhead utility service, or the connection inside a service manhole.
- B. Service points shown on the Contract Documents are approximate only. Contact the serving Utility to determine the exact locations. Install the service conduit as required

by the Utility. Notify the Utility and complete the required applications for inspection. Provide permits, fees, and access for inspections.

- C. If the meter socket is not provided by the Utility, obtain the meter socket as required by the Utility's regulations. Verify the dimensions of the socket and meter to ensure proper installation in the cabinet and conformance with Utility's requirements.
- D. Obtain and provide for utility services required for testing and operation of the electrical systems until acceptance or as directed.

3.04 RECORD DRAWINGS

- A. Provide final record drawings of the system showing conduit and wiring
- B. Record of system wiring diagrams is to be provided. A copy of system wiring diagrams shall be sealed in plastic and mounted near the main distribution panel.

3.05 CONTRACT CLOSEOUT

- A. Provide in accordance with Section 017700.

END OF SECTION 265619

SECTION 265620 – PANELBOARD – LED LIGHTING

PART 1 - GENERAL

1.01 DESCRIPTION

- A. Provide the following are included in the item of the panelboard for Cove Park Option B:
1. Meter Cabinet, Type CP with associated devices and enclosures as detailed in contract documents, Marine NEMA 6P, 316SS.
 2. The Gate Enclosure shall include the following devices and equipment;
 - a) Irrigation Control Panel with enclosure, Marine NEMA 6P, 316SS
 - b) Disconnect Switch (400A, 120/240V) with enclosure, Marine NEMA 6P, 316SS
 - c) Distribution panelboard rated 120/240V-1PH VAC, 225 Amp Mains, 60Hz shall be furnished with breakers for 24HR and LED lighting distribution panel including spares breakers as detailed in the contract documents, with enclosure, Marine NEMA 6P, 316SS. Included in the enclosure will be a 20 amp receptacle controlled by a GFI breaker.
 - d) An Enclosure, Marine NEMA 6P, 316SS with a Magnetic Contactor (100A, 120V), a bypass switch (15A) and a Photoelectric cell twist connect 1000 watts, operating 1.5 fc and 2.25 turn off, mounting as detailed in the Contract Documents.
 - e) A Lighting Distribution panelboard rated 120/240V-1PH VAC, 100 Amp Mains, 60Hz shall be furnished with breakers as detailed in the contract documents, with enclosure, Marine NEMA 6P, 316SS.
 - f) RMC Conduits and a grounding system, including interconnect power and ground conductors, ground rods and connections as indicated and specified in accordance with the National Electrical Code Article 250 and the National Electrical Safety Code.
- B. Provide the following for the Rolling Gates Structures with Area Lighting and/or Urban Amenities Lighting:
1. Meter Cabinet, Type G and G2 with associated device and enclosure, as detailed in the Contract Documents:

- a. A Raintight Disconnect as required by the Utility Company.
 - b. For Meter Cabinet, Type G provides a Power Distribution panelboard rated 120/240V-3PH VAC, 100 Amp Mains, 60Hz shall be furnished with breakers as detailed in the Contract Documents. For Meter Cabinet Type G2 provides a Power Distribution panelboard rated 120/240V-3PH VAC, 220 Amp Mains, 60 Hz shall be finished with breakers as detailed in the Contract Documents.
 - c. For control of the Urban Amenities Lighting provide a 30-amp magnetic contactor in an enclosure with a bypass switch. The contactor will be controlled by a twist lock photocontrol control cell mounted in a NEMA twist lock receptacle.
 - d. The Meter Cabinet will be provided with heater and thermostat.
 - e. The wiring for all devices and enclosures will be in conduit, fitted with grounding bushings, conduit less than 1 inch diameter may use plastic bushings.
- C. Provide the following inside the panelboard for Area Lighting and/or Urban Amenities Lighting:
1. Meter Cabinet, Type R with associated device and enclosure, NEMA 3R.
 2. Disconnect Breaker with enclosure, NEMA 3R
 3. Distribution panels rated 120/240V-1PH VAC, 60Hz shall be furnished with breakers for 24HR and LED lighting and LED Amenity Strip lighting distribution panel including spares, NEMA 3R and spare breakers.
 4. Each lighting luminaries will be equipped with own individual photo cell. The photoelectric control units shall be outdoor type, single pole-single throw, 105-277VAC, 50/60 hertz, and shall be rated for a minimum of 1800 Volt-Ampere and 5000 on-off operations. Operating levels shall be 1 + 0.2 FC (nominal) for turn-on and 3 FC (average) for turn-off conditions. Average power consumption of the unit shall be less than 1.6 Watts. The unit shall be rated for ambient temperature range of -65 degrees F to + 158 degrees F and shall be moisture resistant for 100% relative humidity. Chassis of the units shall be molded phenolic with three twist lock type blades and removable neoprene gasket, all in conformance with NEMA standards. The photoelectric control units shall be equipped with encapsulated surge protection devices and hermetically sealed photocell, and shall be furnished with receptacle units and necessary mounting devices.
- D. Type of power from utility poles or nearby 24HR service panel shall be provided per the table shown below.

SITE No.	DISTRIBUTION POWER	Meter Cabinet Type	DESCRIPTION	Power Sources
1	120/240v 1 Ph 3 wire	Type R	Lighting & Urban Amenity (UA)	Utility Pole
2	120/240v 3 Ph 4 wire	Type G	3Ph Gate Power & Urban Amenity (UA)	Utility Pole #7207JC
3	120/240v 3 Ph 4 wire	Type G	3Ph Gate Power & Urban Amenity (UA)	Utility Pole #26142JC
4	120/240v 1 Ph 3 wire	Type R	Lighting & Urban Amenity (UA)	Utility Pole #65092JC
5	120/240v 3 Ph 4 wire	Type G2	3Ph Gate power, Lighting & Urban Amenity (UA)	Utility Pole #61574JC
6	120/240v 3 Ph 4 wire	Type G	3Ph Gate power & Lighting power	Utility Pole #1668HB
7	From Site 6		Urban Amenity (UA)	
8	120/240v 3 Ph 4 wire	Type G	3Ph Gate power & Urban Amenity (UA)	Utility Pole
9	120/240v 3 Ph 4 wire	Type G2	3Ph Gate power & Urban Amenity (UA)	Underground
10A	120/240v 1 Ph 3 wire	Type R	Urban Amenity (UA)	Underground
10B	120/240v 1 Ph 3 wire	Type R	Urban Amenity (UA)	Underground
11	From Site 12		3Ph Gate Power & Urban Amenity (UA)	
12	120/240v 3 Ph 4 wire	Type G2	3Ph Gate power & Urban Amenity (UA)	Utility Pole #4163 HOB
13	120/240v 3 Ph 4 wire	Type G2	3Ph Gate Power, Lighting & Urban Amenity (UA)	Utility Pole #65409
14	120/240v 3 Ph 4 wire	Type R	3Ph Gate Power & Urban Amenity (UA)	UnderGround Service

1.02 PAYMENT

- A. No separate payment shall be made for performing any Work required under this Section. All costs for Work required by this Section shall be included in the applicable lump sum(s), or allowance(s) as set forth in Section 012901.

1.03 REFERENCES

A. Federal Specifications (FS):

1. W-P-115C: Panel, Power Distribution.

B. National Electrical Manufacturers Association (NEMA):

1. 250: Enclosures for Electrical Equipment (1000 volts maximum).
2. AB 1: Molded Case Circuit Breakers.
3. PB 1: Panelboards.
4. KS-1: Heavy Duty Enclosed and Enclosed and Dead-Front Switches (600 Volts Maximum).

C. National Fire Protection Association (NFPA):

1. 70: National Electrical Code (NEC).

D. Underwriter's Laboratories, Inc. (UL):

1. 50: Cabinets and Boxes.
2. 67: Panelboards.
3. 86A: Wire Connectors and Soldering Lugs for Use with Copper Conductors.
4. 98: Disconnect Switches.
5. 977: Fused Power-circuit Device

1.04 RELATED SECTIONS

A. General Conditions Article 4.7 – Shop Drawings and Other Submittals

B. Section 012901 – Measurement and Payment

C. Section 014300 – Quality Requirements

D. Section 017700 – Contract Closeout

E. Section 260526 - Grounding and Bonding for Electrical Systems

1.05 SUBMITTALS

A. General – Submit the following according to General Conditions Article 4.7.

- B. Submit manufacturer’s dimensioned outline drawing, fuse rating and type, Cable terminal size and product data sheets.
- C. Submit manufacturer’s certificates for proof that all materials comply with specified requirements.
- D. Submit manufacturer’s certified destructive test reports completed by an accredited independent testing laboratory, indicating compliance with any specified factor or safety.
- E. Submit an Operations and Maintenance Manual as per Section 017823.

1.06 QUALITY ASSURANCE

- A. Refer to Section 014300.
- B. All panelboards shall be designed, manufactured, and assembled in accordance with the referenced standards.
- C. Listing and Labeling: All panelboards shall be listed and labeled by Underwriter’s Laboratories, Inc. (UL) or other nationally-recognized testing laboratory (NRTL).
- D. Service entrance panelboards shall be UL/NRTL-labeled as suitable for that purpose.

PART 2 - PRODUCTS

2.01 PANELBOARD

- A. Provide panelboard with front accessibility and front connected equipment to meet space.
- B. Furnish panelboards complete with main circuit breaker, electrical distribution panels, metering device, mobile generator receptacle.
- C. Copper Ground Bar: Standard bolted.
- D. Copper Neutral Bar: Standard bolted.
- E. Provide panel with the voltage, frequency, current ratings of main, ampere ratings of branches, as indicated conforming to NEMA Standard PB1, Federal Specification W-P-115A. U.L. 67, and the NEC.

2.02 PANELBOARD ENCLOSURE

- A. Cove Park, Option B: Panelboard enclosures shall be pad-mountable free-standing, marine grade NEMA 6P, Type 316, vandal resistant stainless steel with padlockable hinged door.

- B. Resist Wall: Panelboard enclosures shall be pad-mountable free-standing, NEMA 3R, vandal resistant cast aluminum with padlockable hinged door.

2.03 MAIN FUSED DISCONNECT SWITCH AND ENCLOSURE - COVE PARK OPTION B

- A. Main fused disconnect switch shall be 240 VAC 1 single phase three wire, Min. 400A rated shall be provided.
- B. Fusible switches shall be suitable for service entrance equipment and be equipped with factory installed neutrals, as noted on the Contract Drawings.
- C. Switch assembly and operating handle shall be an integral part of the enclosure.
- D. Switches rated 200 A to 600 A shall have reinforced fuse clips.

2.04 MAIN FUSED DISCONNECT SWITCH AND ENCLOSURE - RESIST WALL

- A. Main fused disconnect switch shall be 480 VAC 3 phase four wire, Min. 100A rated for G and 400A rated for G2 shall be provided for gate power application only.
- B. Fusible switches shall be suitable for service entrance equipment and be equipped with factory installed neutrals, as noted on the Contract Drawings.
- C. Switch assembly and operating handle shall be an integral part of the enclosure.
- D. Switches rated 200 A to 600 A shall have reinforced fuse clips.

2.05 METERING DEVICE

- A. Metering equipment shall be acceptable to the utility, installation shall be in accordance with requirements of the utility by submitting drawings, sketches, catalog information and other appropriate material for approval.

2.06 METERING DEVICE ENCLOSURE – COVE PARK OPTION B

- A. Metering Device Enclosure shall be pad-mountable free-standing, marine grade NEMA 6P, Type 316, vandal resistant stainless steel with padlockable hinged door.

2.07 METERING DEVICE ENCLOSURE – RESIST WALL

- A. Metering Device Enclosure shall be pad-mountable free-standing, marine grade NEMA 3R, vandal resistant cast aluminum with padlockable hinged door.

2.08 FACTORY TESTING

- A. Standard factory tests shall be performed on the equipment provided under this Section. All tests shall be in accordance with the latest version of NEMA and UL standards.

PART 3 - EXECUTION

3.01 INSTALLATION

- A. Mount panelboards, main disconnect switch and metering device enclosure without distortion of the box. Mount such that the height of the top switches or handles do not exceed 6 feet 7 inches from the ground.
- B. panelboards, main disconnect switch and metering device shall be mounted on a concrete pedestal or concrete wall. Exact location shall be coordinated with the Construction Manager.
- C. Hang each door of the cabinet on semi- or fully-concealed hinges with a combination catch and lock.
- D. On cabinets 48 inch high and over, install a 3-point catch assembly latching at top, bottom, and approximate middle.
- E. Verify all panelboards, main disconnect switch and metering device enclosure locks are keyed alike.
- F. Provide typed directory card filled-out to clearly indicate the load served.
- G. Door hinge to be on the side opposite escape route, if applicable.
- H. Ground equipment according to Section 260526.

3.02 CONTRACT CLOSEOUT

- A. Provide in accordance with Section 017700.

END OF SECTION 256620

NO TEXT ON THIS PAGE

SECTION 310930 - GEOTECHNICAL INSTRUMENTATION

PART 1 - GENERAL

1.01 DESCRIPTION

- A. This specifies requirements for furnishing all labor, materials, equipment to perform the activities related to geotechnical instrumentation as specified here in.
 - 1. Types of instrumentation to be installed and monitored include, deformation monitoring points, utility monitoring points, tiltmeters, and observation wells.
 - 2. Design, procurement, provisions, installation, establishment of baseline, monitoring including interpretation of data, maintenance, protection and removal of all geotechnical instrumentation.

1.02 PAYMENT

- A. No separate payment shall be made for performing any Work required under this Section. All costs for Work required by this Section shall be included in the applicable lump sum(s), unit price(s), or allowance(s) as set forth in Section 012901.

1.03 REFERENCES

- A. Unless otherwise noted, the latest edition of the following codes and standards shall govern this work. If any conflicts exist between these codes and standards the more restrictive requirements shall govern.
- B. American Society for Testing and Materials International (ASTM)
 - 1. C 144: Standard Specifications for Aggregate for Masonry Mortar
 - 2. D 1785: Standard Specifications for (Polyvinyl Chloride) (PVC) Plastic Pipe, Schedules 40, 80 and 120
- C. Federal Geodetic Control Committee (FGCC): Standards and Specifications for Geodetic Control Networks.
- D. National Electrical Code (NEC)

1.04 RELATED SECTIONS

- A. General Conditions Article 4.7 – Shop Drawings and Other Submittals.
- B. Section 011100 – Summary of Work

- C. Section 012901 – Measurement and Payment.
- D. Section 014300 - Quality Requirements.
- E. Section 016100 - Control of Materials.
- F. Section 017423 - Cleaning Up.
- G. Section 017700 - Contract Closeout.
- H. Section 023214 – Vibration and Noise Monitoring.
- I. Section 033000 - Cast-In-Place Concrete.
- J. Section 312319 – Dewatering.

1.05 SUBMITTALS

- A. Submit the following qualifications in accordance with General Conditions Article 4.7.
 - 1. Submit the following qualifications four (4) weeks prior to the start of any construction activities.
 - a. Qualifications of the Contractor’s Geotechnical Instrumentation Engineer, as specified in Paragraph 1.06.C.
 - b. Qualifications of the Contractor’s Land Surveyor, as specified in Paragraph 1.06.D.
 - c. Qualifications of the Contractor’s Instrumentation Superintendent, as specified in Paragraph 1.06.E.
 - d. Qualifications of the Contractor’s Instrumentation Technician, as specified in Paragraph 1.06.F.
- B. At least three (3) weeks prior to the start of construction activities in the Zone of Influence for a specified area provide Instrumentation Monitoring Plans and installation details of all instruments specified here in. This shall include but not limited to the following:
 - 1. Drawings showing the layout and locations of instruments, including wire diagrams for power and/or communications. Power lines carrying 110 volts or more shall be enclosed in conduits of the size and materials required by the NEC.
 - 2. Instrument identification numbers.

3. Details of supports, fixtures, etc. required for installation of instruments and associated systems.
 4. Where optical survey methods are used submit the following to demonstrate the manufacturer's stated accuracy and the field procedures and the resulting accuracies meet the specified accuracies at a minimum 95 percent level of confidence:
 - a. Step-by-step procedures for conducting all optical survey measurements to the specified accuracies.
 - b. Types of surveying instruments including manufacture's data sheets.
 - c. Data reduction procedures.
- C. At least two (2) weeks prior to installation of the first type of each instrument submit the instrument manual to the Construction Manager for review. The following information shall include but not limited to:
1. Manufacturers data sheets and operation manuals, including independent testing data or certification to demonstrate conformance with the performance criteria specified for each type of instrument.
 2. Step-by-step procedures, which shall include details of materials, equipment and any other provisions required, for the work related to each type of instrument:
 - a. Acceptance Tests:
 - i. Pre- Installation acceptance tests.
 - ii. Post installation acceptance test and establishment of formal initial readings.
 - iii. Format of test reports
 - b. Instrument Calibration:
 - i. A list of calibration equipment and recommended frequency of calibration.
 - ii. Calibration of readout units and survey equipment
 3. Data Collection and Transmission:
 - a. Location of data storage units and dataloggers

- b. Whether the instrument shall be connected to an individual datalogger or a common datalogger.
 - c. Proposed wireless method of signal transmission
 - d. Step-by-step data collection procedure.
 - e. Reporting formats for each type of instrument.
 - f. Software requirements and instructions, data reduction, processing, and plotting procedures for each type of instrument.
 - g. Plans for primary electrical power, pack-up power, telephone lines, and signal cables for all instruments with conduit where it is required by the NEC and other applicable codes.
4. Maintenance and Protection:
- a. Methods for protecting instruments form damage.
 - b. Maintenance information that shall include, but not limited to, frequency and duration of maintenance as well as equipment and spare parts required for performing maintenance.
5. Reporting format for photographic condition record specified herein.
- D. A Schedule of the instrument procurement, installation, and testing.
- E. Schedules for instrumentation baseline readings report at frequency specified in Paragraph 3.02.A.2 herein.
- F. Before instrument installation, the conditions of each instrumented areas shall be photographically documented, and a standardized record shall be submitted.
- G. Within ten (10) working days after installation of each instrument, submit the installation records which shall include, but not limited to, the following information:
1. A copy of the factory calibration test, including calibration curve with data points clearly indicated, and tabulation of data, manufacturer’s test equipment certification.
 2. Pre/Post-installation acceptance test record forms and formal initial readings.
 3. Installation record sheets, including as-built coordinates.
- H. As-Built Instrument Location Plan:

1. The instrument location plan shall be submitted within three (3) weeks after the completion of the first instrument installation, regardless of instrument type and shall be updated and submitted every four (4) weeks thereafter.
2. Updated plans need not be submitted for periods for which no new instruments have been installed.

1.06 QUALITY ASSURANCE

- A. Comply with the requirements specified in Section 014300.
- B. Contractor or Contractor's instrumentation consultant, responsible for furnishing and installing all geotechnical instrumentation, including all instruments specified here in, maintaining the instruments, as required, and interpreting all data provided or collected shall have the qualifications specified here in. The personnel may be employed by the contractor or may be employed by a specialized instrumentation consultant.
- C. Geotechnical Instrumentation Engineer (GIE) Qualifications:
 1. A State of New Jersey Licensed Professional Engineer specializing in geotechnical instrumentation responsible for designing and monitoring of the types of instruments specified here in and interpretation of the instrument data.
 2. Not less than six (6) years' experience in the installation and monitoring of the geotechnical instrumentation specified herein.
 3. Completed not less than five (5) successful geotechnical instrumentation installation and monitoring projects of similar scope and magnitude within the past ten (10) years.
 4. The GIE shall be onsite to supervise and conduct the pre/post installations of each type of instrumentation. The GIE shall be onsite and supervise the first five (5) installations of each type of instrument, shall oversee and establish the formal initial readings of each instrument installed, shall oversee interpretation of all collected and provide geotechnical instrumentation data.
- D. Contractor's Land Surveyor responsible for optically surveying the instrumentation shall be licensed in the State of New Jersey and have a minimum of three (3) years' experience in execution of survey types and accuracy specified here in. The field survey crew chief shall have a minimum of one (1) year of experience in deformation survey measurements or other optical survey techniques of the types and accuracies specified here in.
- E. Instrumentation Superintendent's qualifications:

1. To be responsible full-time on site during the implementation of the geotechnical instrumentation program.
 2. Not less than six (6) years of direct field experience in the installation and monitoring of the types of instrumentation specified here in and have supervised instrumentation programs of a similar scope and magnitude with similar work conditions.
 3. Shall be available to supervise all instrument installations, pre/post- installation acceptance tests, establish initial readings, collect baseline data, and instrument instrumentation data when the GIE is not present on-site.
- F. The GIE and the Instrumentation superintendent may be the same person with qualifications that satisfied the requirements specified herein.
- G. Instrumentation Technician Qualifications:
1. Not less than one (1) year of experience in the installation and monitoring of the geotechnical instrumentation specified herein.
- H. Perform work in accordance with issued permits, Municipalities (City of Hoboken, City of Jersey City, and Township of Weehawken), the State of New Jersey, Port Authority, Utility Authorities, ordinances, and regulations.

1.07 INSTRUMENTATION INSTALLATION SCHEDULE

- A. Coordinate installation and initialization of instruments with the Construction Manager.
1. Install and record formal initial readings for deformation monitoring point's (DMP) at least 14 days prior to any construction activities in the zone of influence.
 2. Install and record formal initial readings for tiltmeters at least 30 days prior to any work in the zone of influence to the PATH tunnels.
 3. Install and record formal initial readings for observation wells at least 14 days prior to the start of dewatering activities in the zone of influence.
 4. Install and record formal initial readings for settlement Platforms at least 14 days prior to any construction activities in the zone of influence.
 5. Install and record formal initial readings for Inclometers at least 14 days prior to any construction activities in the zone of influence.

1.08 DELIVERY, STORAGE, AND HANDLING

- A. Comply with requirements specified in Section 016100
- B. All instrumentation materials, after receipt the Work site and before installation shall be stored in an indoor, clean, dry and secure storage space. Instruments shall not be exposed to temperatures outside the manufacturer's stated working temperature range.

1.09 SITE CONDITIONS

- A. Geotechnical Investigation Results Report: The report is for information only, which is part of the Contract Documents. The boring logs are included as an appendix in the report and indicate subsurface conditions encountered only the borehole location. This report shall not be construed as to guarantee that other subsurface materials will not be present or that proportions of materials will not vary from that shown on the boring logs. The borehole locations and soil profiles are part of the Contract Drawings.

PART 2 - PRODUCTS

2.01 MATERIALS

- A. All materials shall be new and shall have a design life of at least five (5) years.
- B. Factory calibration shall be conducted on all instruments at the place of manufacture before shipment. Each instrument shall be marked with a unique identification number.
- C. Surface protection for vertically installed instruments shall be flush with the ground surface in paved or other areas. For all instruments requiring surface protection, it shall consist of a Tyler Pipe Model 26T-6855 LF Top Only Roadway box, or approved equal, with a plain 6-inch lock-lid, a Bresnahan Foundry Model 00068 Roadway Box with latching lock-lid, or approved equal.
- D. If not otherwise stated, all graduations shall be in U.S. Customary Units, for example, feet, inches, pounds.
- E. Dataloggers provided shall be capable of retaining setup information and measurements in memory for a minimum of 72 hours in case of a power failure or power interruption. The dataloggers shall have the ability to communicate with short haul or telephone modem. The dataloggers shall be Campbell scientific, model CR1000X, or approved equal.
- F. Cables used to connect the instruments with the dataloggers shall be low smoke zero halogen (LSZH) and shielded to protect against the effect of stray current and electrical induction, water, and weather, and shall be resistant to vandalism and rodent attack.

- G. Equipment shall be housed in secure cabinets that are protected against theft, vandalism, rodents, and the effects of weather.
- H. Survey Instruments:
 - 1. Survey Instruments shall have a minimum accuracy of plus or minus 3.0-arc seconds (standard deviation in accordance with DIN 18723), and a minimum display reading less than or equal the accuracy.
- I. Movement Monitoring:
 - 1. The following types of deformation Monitoring points (DMP) shall be provided at the locations shown in the Instrumentation Monitoring Plan or as directed by the Construction Manager.
 - 2. DMP-Type 1: Consists of an observable punch marked on the top of horizontal surfaces, such as sidewalks, roadways, steel sheeting, piles, etc. The surface within 3-inches of the point shall be cleaned by wire brush or other similar means to permit easy identification of the exact point. The point shall be clearly identified using fluorescent spray paint adjacent the point
 - 3. DMP-Type 2: Consists of target survey prisms or targets suitable for installation in vertical surfaces such as steel, concrete, masonry, and mortar joints. The prisms shall be optically surveyed, or other methods as approved by the Construction Manager.
 - a. The prisms/targets shall be installed at location shown on the Instrumentation Monitoring plan or as directed by the Construction Manager.
 - 4. Settlement platforms will monitor vertical displacements occurring during and after the embankment construction for Cove Park by measuring elevation of top of riser pipe (mounted on platform) using optical surveying methods.
 - a. Provide threaded six (6) inch casing pipe and a three (3) inch inner pipe according to ASTM A53, welding base, standard weight.
 - b. Provide sand base soil aggregate.
 - c. Provide protective base casing as shown in monitoring program.
 - d. Provide protective base casing as shown in Contract drawings.
 - i. The riser(s) will be extended as the fill material is placed to maintain the top of the settlement platform between two (2) and four (4) feet above the average surrounding ground.

- e. Provide surface protection consisting of a roadway box with locking lid, for settlement platforms installed within publicly accessible areas.
5. Tiltmeters:
- a. Tiltmeters shall be biaxial and shall incorporate tilt transducers that are electrolytic levels (also referred to as electro-levels), vibrating wire transducers, accelerometers, or magneto-resistive transducers. A temperature sensor shall be incorporated into each tiltmeter.
 - b. The tiltmeters shall have been proven by data obtained during a minimum of three (3) project applications similar in scope and magnitude, or by laboratory testing, which shall be accepted by the Construction Manager, to have the following performance characteristics:
 - i. Minimum angular range plus or minus 1-degree.
 - ii. Operating temperature range of plus 33 to plus 100-degrees Fahrenheit.
 - iii. Static repeatability of plus or minus 2-arc seconds or better.
 - iv. Maximum temperature sensitivity throughout the entire angular range and operating temperature range of plus or minus 40-arc seconds.
 - v. Zero stability over a minimum period of 90 days at a constant temperature of plus or minus 5-arc seconds or better.
 - c. The tiltmeter electrical cable shall be recommended by the manufacturer of the tiltmeter and shall be shielded with a waterproof jacket.
 - d. Portable readout units shall be recommended by the manufacturer of the tiltmeters. Each tiltmeter shall be connected to a datalogger. The portable readout unit shall be used during installation and for subsequent duplicate readings.
 - e. Housing and mounting brackets shall be recommended by the manufacturer of the tiltmeter.
 - f. Factory calibration of tiltmeters shall consist of calibrations on a mechanical tilting table with a range of plus or minus 1 degree in a minimum of ten equal increments.
 - g. Each tiltmeter shall be protected from damage by installing a protective box provided by the manufacturer, a NEMA 3R enclosure, or equivalent, of

appropriate size to enclose the tiltmeter and to allow for connection to a datalogger.

J. Observation Wells and Piezometers:

1. PVC Pipe:

- a. Unless otherwise directed by the Construction Manager, provide nominal 1-1/2 inch diameter, flush-jointed Schedule 40 polyvinyl chloride (PVC) plastic plain and slotted pipe and couplings, conforming to ASTM D 1785.
- b. Slotted PVC pipe shall have slots nominally 0.01 to 0.02 inch wide and at least 3/4 inch long at the inside circumference of the pipe with a minimum of 120 slots per foot. The bottom of the slotted pipe shall be plugged with a tightly fitted cap. Plain pipe shall be used as riser pipe. The top of the plain pipe shall be threaded and provided with a side-vented plastic cap.

2. Bentonite Pellets:

- a. Bentonite pellets shall be Volclay KWK No. 33, or approved equal.

3. Sand:

- a. Clean, uniform sand with a maximum grain size of 2 mm with less than 3 percent passing a No. 200 U.S. Standard sieve size and a uniformity coefficient less than 4, such as standard 20/40 "Flint Shot" Ottawa Sand supplied by Agsco Corporation, Hasbrouck Heights, New Jersey or approved equal.

4. Pea Gravel:

- a. Clean, uniform pea gravel with a maximum grain size of 1/4 inch with less than 3 percent passing a No. 200 U.S. Standard sieve size.

5. Concrete:

- a. Concrete shall be 3000 psi and shall be in accordance with the Section 033000.

6. Water Level Meter

- a. The water level meter shall be an electrical water level indicator Model 100, manufactured by In-Situ, or approved equivalent.

7. Piezometer:

- a. Piezometers shall be a non-vented pressure sensor, utilizing an internal strain gauge to measure absolute pressure, model Level TROLL 400, manufactured by In-Situ, or approved equal.

8. Surface Protection

- a. In paved areas a steel flush mounted protective casing shall be installed over the PVC pipe, with enough space for the well cap. The flush mount cover shall extend minimum of 12 inches below the ground surface.
- b. In unpaved areas a steel casing shall be installed with a minimum stick-up height of 3 feet and a minimum embedment depth of 3 feet.

K. Inclinometer

1. Inclinometer will measure the angular displacement with respect to the vertical gravity vector at locations shown on the Contract Drawings. The following equipment and materials shall be provided as part of the Inclinometer: inclinometer casing, probe, cables, readout unit, all other accessories as recommended by the manufacture, Durham-Geo Slope Indicator (DGSI), or approved equal.
 - a. Inclinometer casing: minimum outside diameter of 3.34 inches ABS plastic guide casing with adequate wall thickness to withstand external ground pressures, but with flexibility to reflect horizontal ground movement. The casing shall have 4 broached internal keyways equally spaced 90 degrees apart, with twist-tolerance better than one (1) degree per ten (10) foot of length, and shall be compatible with the other inclinometer components.
 - b. Inclinometer Probe: provide DGSI probe model No. 50302510 or later, or approved equal. Probe shall be biaxial consisting of two (2) force accelerometers mounted at 90 degrees, with a wheelbase. Provide a probe carrying case.
 - c. Inclinometer Readout unit: Provide DGSI “Digital DataMate” Model No. 50310900 or later, or approved equal. The readout unit shall be compatible with the Probe. A cable shall be provided in which the probe can connect to the readout unit.
 - d. Grout: the inclinometer casing shall be grouted in place, comprised of Portland cement, bentonite, and water.

PART 3 - EXECUTION

3.01 PRE-INSTALLATION ACCEPTANCE TESTS

- A. When instruments are received at the installation location, perform pre-installation acceptance tests to ensure that the instruments and readout nits are functioning correctly before installation. Pre-installation acceptance tests shall include, but not limited to, the following, as appropriate for the specified instrument:
1. Verify completeness of factory calibration curves and tabulated data.
 2. Verify completeness of manufacturer's final quality assurance inspection checklist.
 3. Verify cable length(s).
 4. Verify unique tag numbers on instrument and cable(s).
 5. Verify that model, dimensions, and materials are correct.
 6. Perform resistance and insulation testing, in accordance with criteria provided by the instrument manufacturer, using a gauge insulation or circuit tester that applies 2 volts or less for resistance testing and 15 volts or less for insulation testing.
 7. Verify that all components fit together in the correct configuration.
 8. Check all components for signs of damage in transit and record any damage noticed.
- B. Complete pre-installation acceptance test record form during testing of each instrument.
- C. An instrument that fails the specified pre-installation acceptance test shall be repaired such that it passes a subsequent pre-installation acceptance test, or shall be replaced by an identical instrument at no additional cost to the DEP.

3.02 INSTALLATION

- A. At least two (2) weeks prior to installation, confirm that the instruments can be installed at the locations indicated on the Instrumentation Monitoring plans. Where instrumentation cannot be installed as indicated, notify the Construction Manager immediately.
- B. Notify the Construction Manager at least 24 hours prior to installing each instrument. Coordinate access to private properties, buildings and other structures through the Construction Manager.

- C. As each instrument is installed, an installation record sheet shall be prepared, including but not limited to, the appropriate items from the following:
1. Project name
 2. Contract name and number
 3. Instrument type and number, including any readout units
 4. Planned location in project coordinates.
 5. Planned orientation
 6. Personnel responsible for installation
 7. Plant equipment used, including diameter and depth of any drill casing or augers used.
 8. Date and time of start and completion of installation.
 9. Available measurements and readings during installation.
 10. As-built coordinates including:
 - a. Elevation referenced to NAVD-88 datum
 - b. Horizontal position referenced to the NAD-83 and to the project baseline station and offset.
 - c. A location sketch showing the instrument number, taped horizontal distances to the instrument, sufficient to establish a unique horizontal position for the instrument.
 11. Results of post-installation acceptance test.
 - a. Weather conditions
 - b. Notes, including but not limited to, problems encountered, delays, unusual features of installation, details that may affect the instruments behavior.
- D. When roadway boxes are installed, they should be free draining. Roadway boxes that are not free draining shall be replaced or repaired.
- E. Installation within New Jersey Transit (NJT), Hudson-Bergen Light Rail (HBLR), and Port Authority (PA) properties, may require track outages and flag protection in accordance with Section 011100. All work activities shall be coordinated through the Construction Manager.

- F. Instruments to be installed on private property shall be coordinated through the Construction Manager.
- G. All Contractor's personnel shall undertake Roadway Worker Protection (RWP) training, and Secure Worker Access Consortium (SWAC) clearance if required by PA, as described in Section 011100.
- H. Drilling:
 - 1. Obtain New Jersey Department of Environmental Protection (NJDEP) well permit.
 - 2. Arrange for utility clearances at each proposed borehole/well location. Inside NJT, HBLR, and PA properties, utilities must be cleared with the assistance of appropriate railroad personnel.
 - 3. Verify the drill rig and other equipment is electrically grounded when performing drilling activities in the railroad right-of-way and in accordance with NJT, HBLR, and PA requirements.
 - 4. Ensure that boreholes in streets or sidewalks are hand augured or hand excavated to a depth of six (6) feet.
 - 5. Boreholes shall be drilled by a method that results in a clean and stable hole of the required diameter and depth. Boreholes shall be cased to the full depth unless soil strata are sufficiently competent for the hole to stay open under dry conditions. Boreholes shall be drilled using clean water.
 - 6. Safely dispose of any effluent water, material cuttings, and refuse in accordance with applicable regulations. Coordinate the disposal with authorities having jurisdiction and the Construction Manager.

3.03 POST-INSTALLATION ACCEPTANCE TESTS AND FORMAL INITIAL READINGS

- A. Unless otherwise specified, all instruments are required to have a post-installation acceptance test performed that demonstrated proper installation and function in accordance with requirements indicated here in or as approved by the Construction Manager.
- B. As a minimum, the acceptance test shall consist of a series of three (3) readings that fall within the range of repeatability stated in the accepted manufacturer's instrument data sheet.
- C. An instrument that fails the specified post-installation acceptance test shall be replaced with an identical instrument.

- D. Upon satisfactory completion of post-installation acceptance test establish the formal initial reading, in a manner specified. A series of reading from a which a formal initial reading is selected will be taken for each new instrument within a period of two (2) hours for surveyed instruments and 30 minutes for non-surveyed instruments. All subsequent readings will be compared to the formal initial readings to determine levels of change.
- E. Confirm and agreement of these readings and the formal initial reading with the Construction Manager.
- F. Post-installation acceptance and forma initial reading data shall be recorded on report sheets that shall include but not limited to the following:
 - 1. Project Name
 - 2. Contractor name and number
 - 3. Instrument type
 - 4. Date and time
 - 5. Observer
 - 6. Readout unit/survey equipment number
 - 7. Instrument number
 - 8. Readings
 - 9. Remarks
 - 10. Visual observations
 - 11. Weather, temperature, construction activities
- G. When undertaking post-acceptance tests and formal initial readings for movement monitoring instruments, survey methods shall conform to the following requirements:
 - 1. For vertical movement monitoring, perform surveys to a precision commensurate with First Order Class II survey work as specified in the FGCC: Standards and Specifications for Geodetic Control Networks. A formal initial reading on a deformation monitoring point shall consist of the closest reading to the average three (3) elevations, from three (3) independent survey setups that meet the closure specified.
 - 2. For horizontal movement monitoring, if a theodolite is used, perform surveys to a precision commensurate with First Order survey work as specified in the FGCC:

Standards and Specifications for Geodetic Control Networks. When distances are measured with a tape, each distance shall be measured two (2) separate times and shall be corrected for temperature and tension of the tape. A formal initial reading on a deformation monitoring point shall consist of the closest reading to the average three (3) readings, from 3 independent survey setups that meet the closure specified. All readings shall be referenced to stable horizontal control points.

- H. A formal initial tiltmeter reading shall consist of the reading closest to the average of the three (3) measurements taken 30 minutes after the instrument is turned on. Each subsequent reading other than the initial formal reading shall consist of a single reading taken with a datalogger. Provide data in format of degrees versus time.
- I. A formal initial piezometer reading shall consist of the reading closest to the average of readings in a 24-hour period. Each subsequent reading other than the initial formal reading shall consist of a single reading taken with a datalogger. Provide data in format of water elevation versus time.

3.04 INSTALLATION OF DEFORMATION MONITORING POINTS

- A. Deformation monitoring points (DMPs) shall be installed at the locations on the Contractors approved Instrumentation Monitoring Plans and/or as directed by the Construction Manager.
- B. Drilled holes, where required, shall be located to avoid historically and architecturally significant features of the structure. Holes for anchor sleeves shall be drilled into horizontal mortar joints where possible.
- C. After completion of installation of DMP's, the as-build location in horizontal position shall be determined to accuracy commensurate with First Order survey work in FGCC: Standards and Specifications for Geodetic Control network. The elevations shall be determined to an accuracy commensurate with First Order Class II survey work as specified in the FGCC: Standards and Specifications for Geodetic Control network.

3.05 INSTALLATION OF SETTLEMENT PLATFORM

- A. The settlement platform shall be constructed in locations and per details on the Contract drawings. Consisting of a square steel platform with a vertical pipe marked to indicate distances above the plate, extending up through the embankment.
- B. In the Load Transfer Platform (LTP) areas, install the settlement platforms on a sand base overlying the upper geosynthetic reinforcement layer and should be midway between the rigid column inclusions. Tamp the sand base to provide a firm, unyielding and level bearing surface for the base plate.

1. The vertical pipe sections shall have a maximum length of four (4) feet, with spacers provided between the casing and the riser pipe at intervals of four (4) feet maximum to ensure concentricity.
 2. A protective casing shall be placed at both ends open around the initial length of casing pipe. Backfill around protective casing with tamped clean sand or gravel to support the pipe in a vertical position during fill placement until fill is placed above metal platform.
- C. As the height of the fill above the settlement platform increases, increase the casing and monitoring riser pipe in maximum four (4) foot increments to maintain the top of the pipe and casing above the fill placement. As each additional section of pipe is added, immediately transfer the pipe cap on the top section of pipe to prevent fill material from entering the casing.
- D. Mark the casing with flags or other noticeable markings, to clearly show its location and to warn workers of its location. Maintain the marking during the entire monitoring period.
- E. Maintain the settlement platforms in working order during the entire monitoring period. Repair or replace settlement platforms damaged by the Contractor at no additional cost to the NJDEP, within 3 days after being damaged.

3.06 INSTALLATION OF BIAXIAL TILTMETERS

- A. Tiltmeters shall be securely mounted to surface using method recommended by the manufacturer, at the locations shown on the Contractor's Approved Instrumentation Monitoring Plan.
- B. Each tiltmeter or group of tiltmeters shall be cabled to a datalogger.
- C. After tiltmeter installation, perform a post-installation acceptance test by reading the tiltmeter to ensure correct functionality.
- D. After tiltmeter installation, the as-built location in vertical and horizontal position shall be determined to an accuracy of plus or minus 0.3-foot.

3.07 INSTALLATION OF OBSERVATION WELL AND PIEZOMETERS

- A. Piezometers shall be installed prior to dewatering and/or filling and in accordance with the Contract Drawings and requirements specified in the Section 312319. Except for those portions of piezometers which must extend through and above the fill, installation of piezometers shall be made prior to placing fill.
- B. Boreholes shall be drilled as specified here in and in accordance with Contractor's approved Instrumentation Monitoring Plan.

- C. All Observation wells shall be abandoned in conformance with New Jersey Administrative CODE (NJAC) regulations.
- D. Install piezometers in boreholes advanced by means of a tricone bit or coring. Casing (4-inch standard weight steel pipe) shall be used to maintain the borehole open; the use of drilling mud will not be permitted. Clean, fresh water shall be used as the drilling fluid for advancing and cleaning out the borehole. The water level in the borehole shall be maintained at the top of the casing at all times during the installation process. After the borehole has been advanced to the depth required, the borehole shall be flushed clean by circulating clean water to the bottom of the borehole through a bit designed to deflect flow upward until no indication of soil or other materials are noted in the drilling fluid which overflows the top of the casing.
- E. When the borehole has been flushed clean, pour sufficient clean, uniform sand into the casing to the required thickness and allow sufficient time for the sand to settle to the bottom. Withdraw the casing this same distance. The thickness of the sand layer within the casing shall be determined by soundings done prior to withdrawing the casing. Lower the slotted pipe section and connected riser pipe into the borehole and set it on the settled sand layer. The riser pipe shall extend to the existing ground surface or above unless otherwise approved by the Construction Manager.
- F. Pour sand into the annular space in the borehole between the casing and the slotted pipe in increments of 6 to 12 inches, withdrawing the casing and tamping the sand after each increment. Continue this procedure to a height of 12 to 18 inches above the top of the slotted pipe. The thickness of each increment of sand shall be determined by soundings prior to withdrawing the casing.
- G. The remainder of the borehole shall be backfilled with clean, coarse to fine sand or pea gravel to an elevation three (3) feet below ground surface. Backfilling and withdrawal of casing shall be accomplished in no greater than 12-inch increments unless otherwise approved by the Construction Manager. Where it is required to isolate or eliminate the influences of conditions such as artesian pressure or perched water tables provide a bentonite seal as shown in the Contractor's approved Instrumentation Monitoring Plan. If a bentonite seal is placed, the sand backfill shall be tamped in 6-inch increments for a minimum of 3 feet above the seal, unless otherwise approved by the Construction Manager.
- H. Conduct time lag tests to demonstrate that the observation wells are functioning properly by adding water or removing water from the riser pipe and taking measurements of water level with time as directed by the Construction Manager to see that the water level returns promptly to the static ground water level. All observation wells shall be left in place until the Construction Manager indicates that readings are no longer required. When no longer required, observation wells shall be cut off 2 feet below grade and filled with concrete grout. Alternate procedures shall be subject to approval of the Construction Manager.

3.08 INSTALLATION OF INCLINOMETER

- A. Install at locations as close as practically possible to specified locations on the Contract Drawings.
- B. The casing shall be installed to the depth specified by the Construction Manager in a minimum of six (6) inch diameter borehole. The boreholes shall be advanced using standard rotary drilling techniques. The casing shall be installed within 1 degree of vertical for the entire length. After installation, the casing groove spiral shall not exceed 1 degree per 10 feet of length and the orientation of the grooves at the top of casing shall be within 10 degrees of the planned orientation. Three (3) split spoon samples shall be taken at the proposed bottom, the first 10 feet from the bottom, the second 5 feet from the bottom and the third at the bottom. The split spoon samples as well as blow counts shall be provided to the Engineer or field representative for evaluation prior to installation of casing.
- C. Install casing in accordance with the manufacturer's recommendations.
- D. Place protective cap at the bottom of the inclinometer casing and seal to provide a water tight seal.
- E. Assemble additional sections of casing using manufacturer approved couplings and lower into the borehole. Fully extend the telescoping casing sections and ensure water tight seal.
- F. Grout annulus between casing and borehole with grout approved by Engineer, prior to installation. Place grout with detachable, flexible tremie pipe or grout pipe, ensure all voids in the annulus between casing and soil are filled.
- G. Immediately after grouting, flush out casing with clean water to ensure casing grooves are free from soils or any other debris.
- H. Install protective steel casing with locking cover over inclinometer casing.

3.09 FIELD CALIBRATION AND MAINTENANCE

- A. When using survey Instruments for collecting deformation monitoring point data, perform an EDM calibrating the zero error and scale error on a calibration baseline that meets the National Geodetic Survey (NGS) standards. The length of the calibration baseline shall span a range of distances that will be encountered during the work. Before performing the calibration, check the adjustments of the tribrachs. The calibration shall be performed every six months, and results applied to each distance measurement.
- B. Ensure that all instruments providing data for the Contract remain functional to end of construction.

- C. Carry out maintenance in accordance with the Contractors approved Instrumentation Monitoring Plan.
- D. Use qualified and accepted instrumentation personnel to replace or repair instruments that are damaged or become non-functional within 72 hours of notification of malfunction. No construction activities shall be permitted until the instruments have been repaired and are collecting data.

3.10 DATA COLLECTION

- A. The Contractor shall be responsible for collection of data for the post-installation acceptance tests and the formal initial readings for all instrumentation.
- B. After agreement of Formal Initial Readings, the Contractor shall be responsible to provide data collection for all instrumentation installed under this Contract.

3.11 DATA REDUCTION, PROCESSING, PLOTTING, AND REPORTING

- A. The Contractor shall be responsible for the reduction, processing, plotting, and reporting of data collected from the instrumentation installed.
- B. The Contractor shall be responsible for reviewing the data in real-time and/or daily and immediately inform the Construction Manager of any exceedances to the response limits.
- C. The Contractor shall be responsible for providing weekly reports to the Construction Manager for review by the Architect/Engineer, including all instruments that are located within active construction zones.
- D. When the Architect/Engineer determines from the data, provided by the Contractor, that a change or trend is apparent, that while not exceeding the response limits specified, precautionary measures may be taken. The Architect/Engineer will notify the Contractor in order to verify the data trends and take appropriate action in accordance with approved Instrumentation Monitoring Plan.
- E. Where data provided to Architect/Engineer from the Contractor, indicating an exceedance in the response limit, all construction activities shall stop, and the actions indicated in the Instrumentation Monitoring Plan shall be implemented.
- F. None of the above shall relieve the Contractor of responsibility for the safety of the work.

3.12 INTERPRETATION OF DATA AND IMPLEMENTATION OF PLANS OF ACTION

- A. Interpret the instrumentation data collected, which shall include making correlations between instrumentation data and specific construction activities. Instrumentation data shall be evaluated to determine whether the response to construction activities is as expected.
- B. Table 1 Shows Response limits for selected instruments:

Table 1 Instrument Response Limits

Instrument	Review Level	Alert Level
DMP Type 1 & 2	Settlement 3/16 inch, change in tilt 0.0005 radians	Settlement 5/16 inch, change in tilt 0.001 radians
Tiltmeters	Change in tilt 0.0005 radians	Change in tilt 0.001 radians
Piezometers	2 feet drop in water Elevation	4 feet drop in water elevation

- C. Response Limits are subject to adjustment by the Construction Manager as indicated by prevailing conditions or circumstances.
- D. Should three (3) successive readings on a specific instrument indicate an accelerated trend, the Contractor and Construction Manager shall meet to discuss possible reasons and potential implications of the movement and determine a suitable response including any actions to be taken by the Contractor to modify his operations to control the trend within response limits.
- E. Response limits for the settlement platforms and inclinometers shall be based on the Contractors final design of the Column supported embankment system.
- F. If a Review Level is reached:
 1. The Contractor shall meet with the Construction Manager to discuss the response action(s). The Contractors qualified instrumentation personnel shall attend as necessary.
 2. If directed by the Construction Manager, during above referenced meeting, that a response action is needed, within 24 hours of receiving the instrumentation data indicating that a Review level has been reached, submit a detailed specific plan of action, based as appropriate on the contingency plan as part of the Instrumentation Monitoring Plan.

3. If directed by the Construction Manager, implement response action(s) within 24 hours of submitted a detailed specific action plan, so that Alert Level is not reached.
 4. Install additional instruments, as directed by the Construction Manager.
- G. Take all necessary steps to ensure the Alert Level is not reached. The Contractor may be directed to suspend construction activities in an affected area with the exception of those actions necessary to avoid reaching the Alert Level.
- H. If an Alert Level is reached:
1. Stop work.
 2. The Contractor shall meet with the Construction Manager to discuss the response action(s). The Contractors qualified instrumentation personnel shall attend as necessary.
 3. If directed by the Construction Manager, during above referenced meeting, that a response action is needed, within 24 hours of receiving the instrumentation data indicating that an Alert level has been reached, submit a detailed specific plan of action, based as appropriate on the contingency plan as part of the Instrumentation Monitoring Plan.
 4. If directed by the Construction Manager, implement response action(s) before resuming work.

3.13 LOSS OF OR DAMAGE TO INSTRUMENTATION

- A. Protect all instruments and appurtenant fixtures, leads, connections, and all other components of instrumentation systems from damage due to construction operations, weather, traffic, rodents, and vandalism.
- B. If an instrument installed by the Contractor, is damage or inoperative, the Contractor's qualified instrumentation personnel shall repair or replace the instrument within 72 hours. Where damage is due to the Contractor's actions, including purchase of defective equipment, repair or replace equipment at no additional cost to the Owner. The Contractor shall stop construction operations in the vicinity of the affected area until the necessary repairs or replacement is to the satisfaction of the Construction Manager. Notify the Construction Manager at least 24 hours before repairing or replacing a damaged or inoperative instrument. The Construction Manager will be the sole judge of whether repair or replacement is required.

3.14 DISCLOSURE OF DATA

- A. The Contractor shall not disclose any instrumentation data to third parties and do not publish data without approval of Construction Manager.

3.15 DISPOSAL OF INSTRUMENTS

- A. All instrumentation shall be removed upon completion of the work unless otherwise directed by the Construction Manager.
- B. To the extent practicable, where instruments have to be removed from floors, walls, ceilings, and facades preserve the appearance of the instrumented area, restore the surface to its original condition to the satisfactory of the property owner and/or the Construction Manager.
- C. Cleanup all instrumented locations in accordance with Section 017423.

3.16 CONTRACT CLOSEOUT

- A. Provide in accordance with Section 017700.

END OF SECTION 310930

NO TEXT ON THIS PAGE

SECTION 311000 - SITE CLEARING

PART 1 - GENERAL

1.01 DESCRIPTION

- A. Provide site clearing as indicated and in compliance with Contract Documents.
- B. Section includes:
 - 1. Clearing and grubbing.
 - 2. Tree and shrub protection and removal.
 - 3. Removal of debris related to clearing and grubbing operations.

1.02 PAYMENT

- A. No separate payment shall be made for performing any Work required under this Section. All costs for Work required by this Section shall be included in the applicable lump sum(s), unit price(s), or allowance(s) as set forth in Section 012901.

1.03 DEFINITIONS

- A. Caliper: Instrument used to measure tree diameter.
- B. Clearing: Removal and disposal of above-ground items defined herein.
- C. Grubbing: Removal and disposal of below-ground items defined herein.

1.04 RELATED SECTIONS

- A. General Conditions Article 4.7 – Shop Drawings and Other Submittals.
- B. General Conditions Article 4.13 – Storage and Site Maintenance.
- C. Section 012901 Measurement and Payment.
- D. Section 014300 - Quality Assurance.
- E. Section 016100 - Control of Materials.
- F. Section 017700 - Contract Closeout.
- G. Section 312300 – Excavation and Fill

1.05 SUBMITTALS

- A. Submit the following in accordance with General Conditions Article 4.7.
 - 1. Permits:
 - a. Copy of NJDEP Approval of Request for Authorization under NJPDES Stormwater General Permit – Construction Activities (5G3).
 - b. For Contractor controlled areas used for its operation, a copy of the approved Soil Erosion and Sediment Control permit issued by the Hudson-Essex-Passaic Soil Conservation District.
 - 2. Certificates:
 - a. Copy of herbicide label bearing EPA Pest Control Products Act and Regulations (PCPA) registration number.
 - b. Copy of Arborist Certification.

1.06 QUALITY ASSURANCE

- A. Comply with the requirements specified in Section 014300.
- B. Comply with requirements of the Soil Erosion and Sediment Control Plan as approved by the Hudson-Essex Passaic (HEP) Soil Conservation District and associated Permits:
 - 1. See the Soil Erosion and Sediment Control Plans and the permits for additional requirements.
 - 2. All construction activities must be performed in accordance with the certified plan, or the Contractor shall prepare and submit its own modification to the certified plan for HEPSCD review and approval prior to commencement of construction activity.
- C. Certifications:
 - 1. Certified Arborist: All tree pruning, tree repair, and tree removal shall be performed by competent workers, under the supervision of an arborist holding certification from the International Society of Arboriculture (ISA) or equivalent education and experience.

1.07 DELIVERY, STORAGE AND HANDLING

- A. Comply with the requirements specified in Section 016100.

- B. All herbicides, insecticides, fungicides and rodenticides, and any other poisonous or harmful materials, are to be stored in a locked enclosure with access by authorized personnel only.
- C. Herbicide: Comply with Federal Insecticide, Fungicide, and Rodenticide Act (FIFRA) – Title 7 U.S.C. Section 136. Submit copy of herbicide label, bearing EPA registration number. Comply with NJDOT Standard Specifications, Section 917.11.03.

1.08 SITE CONDITIONS

- A. Existing facilities, structures, and utilities are shown in accordance with the survey performed by Matrix New World Engineering and records obtained from the local utilities. The indicated locations of underground utilities and structures are approximate. Other utilities may exist which are not indicated. Contractor is responsible for the location and protection of utilities.

PART 2 - PRODUCTS

2.01 MATERIALS

A. WOOD CHIPS

1. Material Source: Imported material.
2. Do not use diseased wood and bark, or trees infected with pest vectors.

2.02 ACCESSORIES

- A. Herbicide: Registered EPA Pesticide.
- B. Tree Wound Paint: Bituminous based paint formulated for tree wounds.

PART 3 - EXECUTION

3.01 EXAMINATION

- A. Verify survey benchmarks and intended elevations for the Work are as indicated.
- B. Verify that measures for the maintenance and protection of pedestrian and vehicular traffic are in place prior to commencing any work on site.
- C. Verify temporary erosion and sediment control measures are installed before commencing with any other work at the site.

- D. Verify location and existence of all underground utilities and structures by contacting utility owners, as required by law. Go to “Call Before You Dig” to receive state-specific information. Access this information by dialing 811 or going to <http://call811.com/map-page/new-jersey>.
- E. Provide 72-hour notice to existing utility owners, prior to beginning construction.
- F. Contact utility companies and authorities to make arrangements for handling and disposal of utilities encountered during construction.

3.02 PREPARATION

- A. Protect benchmarks, survey control points, and existing structures to remain from damage or displacement.
- B. Protect trees and vegetation to remain as indicated on the landscape drawings. Do not cut or injure trees and vegetation outside easement lines and outside designated clearing areas.
- C. Protect existing utilities and structures that are to remain. Notify the owner immediately of damage to or an encounter with an unknown existing utility line. The Contractor shall be responsible for the repairs of damage to existing utility lines that are indicated or made known to the Contractor prior to start of clearing and grubbing operations. When utility lines, which are to be removed, are encountered within the area of operations, notify the Engineer in ample time to minimize interruption of the service.
- D. Protect site features to remain from damage by construction equipment and vehicular traffic.
- E. Keep roads free of dirt and debris at all times.
- F. Identify waste and salvage areas for stockpiling of removed materials.

3.03 RESTORATION

- A. Existing surfaces, features, utilities, or structures that are to remain, but are damaged during construction, shall be restored to at least the condition in which they were found immediately before work began, unless noted otherwise.
- B. Restore damaged utilities to the satisfaction of the utility owner.
- C. Restore damaged private property to the satisfaction of the property owner.

3.04 CLEARING

- A. Remove and dispose of off-site:

1. Trees, snags, brush, shrubs, downed timber, decayed wood, and other vegetative growth.
 2. Rocks, tiles, lumps of concrete, trash piles, debris, refuse, rubbish, and chain link fencing. Remove all evidence of their presence from the surface.
 3. Sidewalks, driveways, vertical curbs, sloping curbs, barrier curbs, and gutters. Sawcut full depth at the limits of removal and remove entire structure. Securely stockpile any items that have been designated for reuse.
 4. Remove existing foundations and junction boxes that are abandoned under the Contract to a minimum depth of 2 feet below the finished grade. Remove other electrical material and equipment that are designated for removal, and dispose of as specified in Subsection 3.11. Obtain Construction Manager approval of methods of removal, and ensure remaining electrical equipment is left undamaged. Salvage and deliver to the municipality removed, above-ground electrical material as required.
 5. Excavate for the removal of existing pipe, inlets, and manholes and backfill with excavated material and compact using the directed method as specified in Section 312300. Unless designated for resetting on the Project, dispose of inlet and manhole castings as specified in Subsection 3.11.
 - a. Seal abandoned pipes and conduits using concrete. Construct the plugs to a depth equal to the diameter of the pipe or conduit, or 2 feet, whichever is less.
- B. Remove from the immediate work site and safely store existing items that are to be reused or reset as part of the Plans, or returned to property owner:
1. Metal picket fencing.
 2. Cobblestones, concrete pavers, brick pavers, and granite blocks.
 3. USPS mailboxes. Notify the USPS before relocating USPS mailboxes.
 4. Local street and road signs to be reset at locations and in the manner acceptable to local authorities and according to the Plans. Ensure that Tourist Oriented Directional Signs and logo signs remain visible to motorists during and after stages of construction. Contractor shall submit signage plan for approval by the Construction Manager prior to commencing construction.
 5. Beam guide rail.
 6. Inlet and manhole castings.
 7. Electrical materials indicated for reuse.

8. Street furniture, including, but not limited to, benches, trash receptacles, etc.

C. Clear ground within limits of work, unless otherwise noted.

D. Manual cutting of trees, stumps, and stubs during clearing shall be as close to ground surface as practicable, but no higher than 6 inches above ground for small trees (8 inches or less), and not higher than 12 inches above ground for larger trees (greater than 8 inches).

E. Obey all federal, state and local regulations and guidance regarding the cutting and disposal of diseased trees and vegetation.

3.05 CLEARING IN WOODED AREAS

A. Chip the cleared wood and directly load the chips into trucks for disposal offsite. Wood chips shall not be stored or stockpiled onsite.

3.06 GRUBBING

A. Remove and dispose of all stumps, buried logs, matted roots, roots larger than 2 inches, and organic materials off site.

B. Roots larger than 2 inches in diameter shall be removed to a depth of 12 inches, and roots larger than 1/2-inches in diameter to a depth of 6 inches.

C. Areas designated to receive pavement or structures shall be grubbed a depth of 18 inches. Measure depths of cut from existing ground surface or proposed finished grade, whichever is lower.

D. Apply herbicide to remaining roots and vegetation to inhibit growth.

E. Depressions made by grubbing shall be filled with suitable material and compacted to conform to original adjacent grade. Use suitable material as specified in Section 312300.

F. Do not grub areas within drip line of trees to remain to avoid damage to roots.

3.07 TREE AND SHRUB REMOVAL

A. Remove trees and shrubs within permanent and temporary easement by felling or cutting individual vegetation and grubbing. Removed trees and shrubs shall be chipped and used for mulch.

3.08 TREE AND SHRUB PROTECTION

A. Protect and prune indicated designated trees and shrubs within the clearing limits.

3.09 PRUNING

- A. Trim dead branches 1-1/2-inches or more in diameter and branches to heights and in a manner as indicated. Neatly cut limbs and branches close to the bole of the tree or main branches. Paint cuts more than 1-1/4-inches in diameter tree wound paint.

3.10 BURNING

- A. Burning is not permitted on site.

3.11 CLEANING

- A. Promptly dispose of excess and unsuitable material off site.
- B. All timber on the project site noted for clearing and grubbing shall become the property of the Contractor and shall be removed from the site. Remove debris, junk, and trash from site.
- C. Leave site in clean condition, ready for subsequent work.
- D. Clean up spillage and wind-blown debris before entering public or private property adjacent to site.
- E. Construction Waste Disposal: Comply with waste disposal requirements in General Conditions Article 4.13.

3.12 CONTRACT CLOSEOUT

- A. Provide in accordance with Section 017700.

END OF SECTION 311000

NO TEXT ON THIS PAGE

SECTION 312200 - GRADING

PART 1 - GENERAL

1.01 DESCRIPTION

- A. Provide grading as indicated and in compliance with Contract Documents.
- B. Section Includes:
 - 1. Rough grading.
 - 2. Finish grading.
 - 3. Stockpiling of topsoil and subsoil.
 - 4. Disposal of unsuitable and excess materials.

1.02 PAYMENT

- A. No separate payment shall be made for performing any Work required under this Section. All costs for Work required by this Section shall be included in the applicable lump sum as set forth in Section 012901.

1.03 DEFINITIONS

- A. Unsuitable Material: Defined in Section 312300.
- B. Foundation Influence Zone (under foundations, pavements, or sidewalks): Area below base bounded by 1/2H:1V slope extending outward that complies with OSHA's Excavations standards at 29 CFR Part 1926, Subpart P.
- C. Utility Influence Zone (around piping or ducts): Area below with limits bounded by perpendicular line, 6 inches (150 mm) below pipe or duct with a 1/2H:1V slope extending outward from that line, that complies with OSHA's Excavations standards at 29 CFR Part 1926, Subpart P.
- D. Railroad Influence Zone (outward from tracks): Area with limits bounded by perpendicular line, 20 feet in each direction from the centerline of the track.

1.04 RELATED SECTIONS

- A. General Conditions Article 4.7 – Shop Drawings and Other Submittals.
- B. Section 011100 - Summary of Work.

- C. Section 011414 - Control of Work.
- D. Section 012901 – Measurement and Payment
- E. Section 014300 - Quality Requirements.
- F. Section 015000 - Temporary Facilities and Controls.
- G. Section 017423 - Cleaning Up.
- H. Section 017700 - Contract Closeout.
- I. Section 312300 - Excavation and Fill.

1.05 QUALITY ASSURANCE

- A. Comply with the requirements specified in Section 014300.

1.06 SITE CONDITIONS

- A. Existing Conditions:

1. See Section 011414 for additional requirements.
2. Verify location of existing underground utilities and structures by contacting utility owners, as required by law. Go to “Call Before You Dig” to receive state-specific information. Access this information by dialing 811 or going to <http://call811.com/map-page/new-jersey>.

- B. Geotechnical Investigation Results Report: The report is for information only and is not part of the Contract Documents. Logs of borings are included in the report and indicate conditions encountered only at test boring locations. Nothing in the Contract Documents shall be construed as guarantee that other materials will not be encountered or that proportion of materials will not vary from proportions shown on the logs of test borings.

PART 2 - PRODUCTS

- A. (Not Used)

PART 3 - EXECUTION

3.02 EXAMINATION

- A. Verify survey benchmarks and intended elevations for the Work are as indicated.

- B. Verify temporary erosion and sediment control measures are installed before commencing with any other work at the site.
- C. Immediately notify the Construction Manager if suspected hazardous materials are encountered and cease operations in that area.
- D. Identify areas loosened by frost action, softened by flooding or weather, or containing unsuitable material, and notify the Construction Manager.

3.03 PREPARATION

- A. Remove material loosened by frost action, softened by flooding or weather, or containing unsuitable material, as directed by the Construction Manager. Replace and compact to same requirements as for specified fill in Section 312300.
- B. Identify required lines, levels, grades, and datum.
- C. Stake and flag locations of known utilities.
- D. Locate, identify, and protect from damage all above- and below-ground utilities to remain.
- E. Notify utility owner prior to removal or relocation of utility. See Section 011100 and Section 015000 for notification requirements.
- F. When necessary to excavate through roots of trees or vegetation to remain, perform work by hand and cut roots with sharp axe.

3.04 ROUGH GRADING

- A. Topsoil removal and stockpiling:
 - 1. Strip topsoil from areas that are to be excavated, landscaped, or graded.
 - 2. Separate organic matter (e.g. root zones) from topsoil. Dispose of organic material off site.
 - 3. Do not strip topsoil while wet.
 - 4. Stockpile excavated topsoil on site. Do not mix topsoil with foreign materials.
- B. Subsoil removal and stockpiling:
 - 1. Remove subsoil from areas that are to be excavated, landscaped, or graded.
 - 2. Do not remove wet subsoil unless it is subsequently processed to obtain optimum moisture content.
 - 3. Stockpile suitable subsoil on-site.

- C. Provide for free drainage of construction site.
- D. Benching Slopes: Horizontally bench existing slopes greater than 4H:1V to key fill material to slope for firm bearing.
- E. Stability: Replace damaged or displaced subsoil to same requirements as for specified fill in Section 312300.
- F. Disc level surfaces.
- G. Rough grade site to achieve lines and grades indicated with allowances for imported fill thicknesses.
- H. Provide positive drainage away from buildings and structures by sloping minimum of 2.5 inches over 10 feet, or as indicated on the Contract Drawings.

3.05 FINISH GRADING

- A. Before finish grading:
 - 1. Verify subgrade is contoured and compacted.
 - 2. Verify backfill has been inspected.
- B. Fine grade to eliminate uneven areas and depressions. Follow profiles and contours of subgrade and bring to finish grade as indicated.

3.06 STOCKPILING

- A. Location: As indicated on the permit plans. Do not locate stockpiles over existing or new utilities unless directed.
- B. Height: 8 feet maximum.
- C. Slope: 2H:1V maximum.
- D. Drainage: Grade to prevent standing water.
- E. Provide erosion and sediment control around downhill-side of stockpile perimeter.
- F. All soil to be exposed or stockpiled for a period of greater than 14 days, and not under active construction, will be temporarily seeded and hay mulched or otherwise provided with vegetative cover. This temporary cover shall be maintained until such time whereby permanent restabilization is established.

3.07 EXCESS MATERIAL

- A. Excess non-contaminated and clean grading material, suitable for backfilling or site grading, that is not necessary to complete the work at the Project site shall be disposed off-site in accordance with the Contract Documents.
- B. Dispose offsite unsuitable materials and excess materials not received as per the Contract Documents or by the Construction Manager.

3.08 TOLERANCES

- A. Subgrade:
 - 1. Elevation: 2 inches, from required elevation.
 - 2. Grade: 1 inch per 10 feet.
- B. Finish Grade:
 - 1. Elevation: 1/2 inch, from required elevation.

3.09 FIELD QUALITY CONTROL

- A. See Section 312300 for compaction and testing requirements.

3.10 CLEANING

- A. See Sections 011414 and 017423 for additional requirements.
- B. Remove unused stockpiles, grade area to prevent standing water, protect from erosion, and stabilize.
- C. Leave site clean and raked, ready to receive landscaping.

3.11 CONTRACT CLOSEOUT

- A. Provide in accordance with Section 017700.
- B. Submit existing utility location information as part of record drawings. Include ticket numbers and original information from utility owners.

END OF SECTION 312200

NO TEXT ON THIS PAGE

SECTION 312300 - EXCAVATION AND FILL

PART 1 - GENERAL

1.01 SUMMARY

- A. Provide excavation and fill as indicated and in compliance with Contract Documents. Comply with the requirements specified in Section 021600.
- B. Section includes:
 - 1. Excavation and fill for: Foundations, structures, utilities, and pavement, site drainage, structures, and features.
 - 2. Embankments.
 - 3. Alternate fill, Controlled Low-Strength Material (CLSM).
 - 4. Soil and aggregate materials.
 - 5. Compaction and testing.

1.02 PAYMENT

- A. No separate payment shall be made for performing any Work required under this Section. All costs for Work required by this Section shall be included in the applicable lump sum, unit price(s), or allowance(s) as set forth in Section 012901.

1.03 REFERENCES

- A. ASTM International (ASTM):
 - 1. C33: Standard Specification for Concrete Aggregates.
 - 2. C150: Standard Specification for Portland Cement
 - 3. C495: Standard Test Method for Compressive Strength of Lightweight Insulating Concrete
 - 4. C618: Standard Specification for Coal Fly Ash and Raw or Calcined Natural Pozzolan for Use in Concrete
 - 5. D421: Standard Practice for Dry Preparation of Soil Samples for Particle-Size Analysis and Determination of Soil Constants.
 - 6. D422: Standard Test Method for Particle-Size Analysis of Soils.

7. D698: Standard Test Methods for Laboratory Compaction Characteristics of Soil Using Standard Effort (12,400 ft-lbf/ft³ (600 kN-m/m³)).
 8. D1556: Standard Test Method for Density and Unit Weight of Soil in Place by the Sand-Cone Method.
 9. D1557: Standard Test Methods for Laboratory Compaction Characteristics of Soil Using Modified Effort (56,000 ft-lb/ft³ (2,700 kN-m/m³)).
 10. D2167: Standard Test Method for Density and Unit Weight of Soil in Place by the Rubber Balloon Method.
 11. D2487: Standard Practice for Classification of Soils for Engineering Purposes (Unified Soil Classification System).
 12. D4318: Standard Test Methods for Liquid Limit, Plastic Limit and Plasticity Index of Soils.
 13. D5084: Standard Test Methods for Measurement of Hydraulic Conductivity of Saturated Porous Materials Using a Flexible Wall Permeameter.
 14. D5971: Standard Practice for Sampling Freshly Mixed Controlled Low-Strength Material.
 15. D6938: Standard Test Methods for In-Place Density and Water Content of Soil and Soil-Aggregate by Nuclear Methods (Shallow Depth).
- B. American Association of State Highway and Transportation Officials (AASHTO)
1. M 43: Standard Specification for Sizes of Aggregate for Road and Bridge Construction
- C. Occupational Safety and Health Administration (OSHA) Standards and Regulations:
1. 29 CFR 1926, Subpart P: Safety and Health Regulations for Construction, Excavations.
- D. State Department of Transportation (DOT):
1. NJDOT Specifications: New Jersey Department of Transportation Standard Specifications for Road and Bridge Construction, current edition.
- 1.04 RELATED SECTIONS
- A. General Conditions Article 4.7 – Shop Drawings and Other Submittals.
- B. Section 011414 - Control of Work.

- C. Section 012901 - Measurement and Payment.
 - D. Section 014300 - Quality Requirements.
 - E. Section 015713 – Erosion Control, Sedimentation, and Containment of Construction Materials.
 - F. Section 017700 - Contract Closeout.
 - G. Section 021600 - Excess Clean Fill, Contaminated Soil, and Groundwater Management and Disposal.
 - H. Section 023214 – Vibration and Noise Monitoring.
 - I. Section 023219 - Subsurface Utility Locating (Potholing).
 - J. Section 031000 - Concrete Formwork.
 - K. Section 033000 - Cast-in-place Concrete.
 - L. Section 033400 – Controlled Low Strength Material
 - M. Section 312319 - Dewatering.
 - N. Section 315000 - Excavation Support Systems.
- 1.05 CLASSIFICATION OF EXCAVATION
- A. Excavation is part of the lump sum contract price for the entire project. Excavation is not classified.
- 1.06 DEFINITIONS
- A. Percent Compaction or Compaction Density: The field dry density of compacted material, expressed as a percentage of the maximum dry density.
 - B. Field Dry Density or Field Density: In-place density as determined by ASTM D1556 (Sand Cone Method), ASTM D2167 (Rubber Balloon Method), or ASTM D6938 (Nuclear Method).
 - C. Maximum Dry Density: Laboratory density as determined by ASTM D698 (Standard Proctor) or ASTM D1557 (Modified Proctor) and occurring at the optimum moisture content of the material being tested.
 - D. Proof Roll: Single pass of a drum or rubber tire roller, having a gross load between 25 to 50 tons. Rubber tire rollers shall have tires capable of operating at inflation pressures ranging from 90 to 150 psi.

- E. Utility: The company, agency, or other entity that provides service.

1.07 SUBMITTALS

- A. Submit the following in accordance with General Conditions Article 4.7:

1. Temporary excavation and shoring drawings for worker protection in accordance with Section 315000.
2. Gradation analyses for all import material. The supplier's test results shall be no more than 6 months old.
3. Dewatering plan including disposition of groundwater in accordance with Section 312319.
4. Materials Sources including name of source, location, date of sample, sieve analysis, and laboratory compaction characteristics.
5. Test and Evaluation Reports:
 - a. Field density testing reports: Provide results from field density testing of prepared subgrade and compacted fill.
 - b. Grain-size analyses.
 - c. Laboratory compaction characteristics of soils.
 - d. Moisture content.
6. Controlled Low Strength Material mix design, test results, materials, and material sources.

1.08 QUALITY ASSURANCE

- A. Comply with the requirements specified in Section 014300.
- B. Sustainability Standards Certifications.
- C. Testing shall be performed as specified herein. The Contractor shall engage an independent testing laboratory to be responsible for field testing, inspection, and certified reports. The Contractor's independent testing laboratory shall perform all soil analyses and compaction testing to comply with the requirements specified herein. Test reports shall be submitted to the Construction Manager daily.

In addition to testing performed by the Contractor, the Construction Manager may perform quality assurance testing as deemed advisable. If compaction is found non-

conforming, Contractor shall be responsible for cost of DEP testing and inspection and shall satisfactorily recompact the areas to comply with the Contract requirements.

- D. Protect excavations by shoring, bracing, sheet piling, underpinning or other methods required to prevent cave-in of loose soil. Protection shall be in accordance with OSHA 29 CFR 1926, Subpart P: Safety and Health Regulations for Construction.

1.09 DELIVERY, STORAGE AND HANDLING

- A. Comply with the requirements in Section 016100.
- B. Provide an area for each stockpile of adequate size, reasonably uniform in cross-section, well drained, and cleared of foreign materials. Locate the piles so that there is no contamination by foreign material and no intermingling of aggregates from adjacent piles. Do not use steel-tracked equipment on the stockpiles.
- C. Place bulkheads between aggregates from different sources, geological classifications, or of different gradings. If blending aggregates of different gradings and from different sources, proportion through weigh hoppers. Segregated or contaminated aggregates will be rejected. If a stockpile is rejected for segregation, it may be reconstructed for further evaluation. Use methods that prevent segregation when charging aggregates from stockpiles.
- D. Do not use washed aggregates sooner than 24 hours after washing or until the surplus water has drained and the material has a uniform moisture content.
- E. Temporarily store excavated soil in stockpiles in well-drained areas no closer than 50 feet from streams, wetlands, floodplains, or other waterbodies. Construct stockpiles on polyethylene sheeting. Overlap joints in the underlying polyethylene sheeting a minimum of 12 inches. Contain stockpiles with haybales or silt fence placed continuously at the perimeter of the stockpiles. Construct stockpiles to heights not exceeding 15 feet and with side slopes no steeper than 2H:1V. Segregate material of differing types and levels of contamination depending on reuse or disposal.
- F. Protect and maintain the stockpile and embankment until reuse or disposal. Provide protection for the stockpile to control the stormwater run-off, erosion, and unauthorized contact. Where the material in the stockpile is saturated, pitch the bottom polyethylene sheeting towards a discharge basin to collect water drained from the stockpile. Manage the collected water in the same manner as that generated during dewatering operations.
- G. Maintain the polyethylene sheeting or replace it as needed for as long as the stockpile remains. Periodically inspect stockpiles to ensure that material is not released into the surrounding environment.
- H. If the stockpile remains exposed for more than 15 days, temporarily seed according to soil erosion and sediment control standards.

1.10 SITE CONDITIONS

A. Existing Conditions:

1. Geotechnical Investigation Results Report: The report is for information only and is not part of the Contract Documents. Logs of borings are included in the report and in the Plans and indicate conditions encountered only at test boring locations. Nothing in the Contract Documents shall be construed as guarantee that other materials will not be encountered or that proportion of materials will not vary from proportions shown on the logs of test borings.

PART 2 - PRODUCTS

2.01 FILL MATERIALS

- A. Suitable Material: Material from on-site excavation and permitted off-site sources that meets all of the specified requirements for its intended use and is not unsuitable. Wet subgrade material that meets other requirements for suitable material is suitable.
- B. Unsuitable Material: Material that fails to meet requirements for suitable materials or contains any of the following:
 1. Organic clay, organic silt, or peat, as defined in ASTM D2487.
 2. Vegetation, wood, roots, leaves, and organic, degradable material.
 3. Rock, stones or rock fragments over 6 inches in any dimension.
 4. Porous biodegradable matter, excavated pavement, broken concrete, construction debris, rubbish, or refuse.
 5. Ice, snow, frost, or frozen soil particles.
 6. Alternative Fill, as defined by NJDEP Fill Material Guidance for SRP Sites (2015).
 7. Soil with free and/or residual product.
- C. General Fill: Suitable, unclassified material.
- D. Structural Fill: Suitable material that is classified by the Unified Soil Classification System (USCS) in accordance with ASTM D2487 as GW, GP, GM, GC, SW, SP, SM. Verify that the largest particles in the fill are no greater in dimension than one-half the thickness of the compacted lift thickness.
 1. Gradation: Table 312300-1

Table 312300-1	
Sieve Designation (Square Mesh)	Percentage Passing (By Weight)
4 inches	100
No. 40	0-70
No. 200	0-10

- E. Embankment Fill: Structural Fill; Classified in accordance with ASTM D2487 classification as GW, GP, GM, GC, SW, SP, SM.
- F. Concrete Fill or Concrete Bedding: Comply with the requirements specified in Section 033000, Class B concrete.
- G. Granular Fill:
 - 1. Dense-Graded Aggregate (DGA): Use virgin DGA as specified in NJDOT Specifications Section 901.10, including requirements that it be listed on NJDOT's Qualified Products List (QPL), which can be found at <http://www.state.nj.us/transportation/eng/materials/qualified>. Do not use carbonate rock. Use DGA for QPS. Coarse Aggregate, Gravel, Stone Bedding, Crushed Stone, Broken Stone:
 - 2. Coarse Aggregate: Use coarse aggregate as specified in NJDOT Specifications Section 901.03. Where ¾-inch aggregate is specified, use No. 67. Where a size is not specified, use No. 57.
- H. Sand: Use sand as specified in NJDOT Specifications Section 901.06.02.
- I. Soil Aggregate: Use soil aggregate as specified in NJDOT Specifications Section 901.11.
- J. Storage Gravel: Coarse aggregate No. 2 as specified in AASHTO M43.
- K. Choker Course: Coarse aggregate No. 57 as specified in AASHTO M43.
- L. Permeable Aggregate Base: Dense-Graded Aggregate as specified in Section 2.01 G
- M. Drainage Backfill: For Application within Cove Park only. Coarse aggregate No. 7 as specified in AASHTO M43.

- N. Riprap: For Application within Cove Park only. Riprap stones as specified in NJDOT Specifications Section 901.08. Where a designated median stone size (d_{50}) is not specified, use $d_{50} = 6''$.
- O. Filter Sand: For Application within Cove Park only. ASTM C33.
- P. Pipe Bedding: For Application within Cove Park only. Class C Bedding as specified in NJDOT Specifications Section 909.01.03.
- Q. Trench Backfill: For Application within Cove Park only. Coarse Aggregate as specified in NJDOT Specifications Section 901.03.
- R. Granular bedding: Use bedding where shown or as required by the Construction Manager.
 - 1. Coarse Aggregate: Use coarse aggregate as specified in NJDOT Specifications Section 901.03. Where $\frac{3}{4}$ -inch aggregate is specified, use No. 67. Where a size is not specified, use No. 57.
 - 2. Soil Aggregate: Use soil aggregate as specified in NJDOT Specifications Section 901.11. Where a size is not specified, use granular soil with gradation of Table 312300-2.

Table 312300-2	
Sieve Designation (Square Mesh)	Percentage Passing (By Weight)
1 inch	100
No. 4	82-100
No. 200	0-12

- S. Select Borrow:
 - 1. Well-graded, coarse-grained soil; classified in accordance with ASTM D2487 as GW, GW-GM, GW-GC, SW, SW-SM, or SW-SC.
 - 2. Soil particles: ASTM C33, physical property requirements.
 - 3. Gradation: Table 312300-3.

Sieve Designation (Square Mesh)	Percentage Passing (By Weight)
3 inches	100
1-1/2 inches	70-100
3/4 inches	50-85
No. 4	30-60
No. 50	10-25
No. 200	0-5

2.02 GEOTEXTILE FABRIC

1. Geotextile Fabric: Consisting only of long-chain polymeric fibers or yarns formed into a stable network; 95 percent by weight shall be polyolefins or polyesters. Non-woven.
 - a. Apparent Opening Size: 70 maximum (ASTM D 4751)
 - b. Water Permittivity: 1.7 sec^{-1} minimum (ASTM D 4491)
 - c. Grab Tensile Strength: 120 lbs minimum (ASTM D 4632)
 - d. Ultraviolet Radiation Stability: 70% strength retained minimum after 500 hours in weatherometer (ASTM D 4355)
 - e. Basis of Design Products: Geotextile fabric made by TenCate Mirafi, US Fabrics, Inc., StrataTex Systems, Inc., or approved equal.

2.03 BURIED WARNING AND IDENTIFICATION TAPE

1. Polyethylene plastic warning tape manufactured specifically for warning and identification of buried utility lines. Provide tape on rolls, 3-inch minimum width, color coded as specified below for the intended utility with warning and identification imprinted in bold black letters continuously over the entire tape length. Warning and identification to read, “CAUTION, BURIED (intended service) LINE BELOW” or similar wording. Color and printing shall be permanent, unaffected by moisture or soil.
 - a. Warning Tape Color Codes:
 - Red: Electric
 - Orange: Telephone and Other Communications
 - Blue: Water Systems
 - Green: Sewer Systems (Storm and Sanitary)

- b. Warning Tape for Metallic Piping: Acid and alkali-resistant polyethylene plastic tape conforming to the width, color, and printing requirements specified above. Minimum thickness of tape shall be 0.003 inch. Tape shall have a minimum strength of 1,500 psi lengthwise, and 1,250 psi crosswise, with a maximum 350 percent elongation.
- c. Warning Tape for Non-Metallic Piping: Provide polyethylene plastic tape conforming to the width, color, and printing requirements specified above, with a minimum thickness of 0.003 inch, and a minimum strength of 1,500 psi lengthwise and 1,250 psi crosswise. Manufacture tape with integral wires, foil backing, or other means of enabling detection by a metal detector when tape is buried up to 3 feet deep. Encase metallic element of the tape in a protective jacket or provide with other means of corrosion protection.

2.04 EQUIPMENT

- A. Compaction equipment shall be capable of consistently achieving the specified compaction requirements.

PART 3 - EXECUTION

3.01 EXAMINATION

- A. Verify that dewatering and excavation support systems that are required are in place before commencing with excavation.
- B. Verify that excavation safety and support systems meeting the requirements of OSHA 29 CFR 1926, Subpart P: Safety and Health Regulations for Construction are in place before commencing with excavation.
 - 1. Comply with minimum slopes for laying back excavations or materials in accordance with OSHA 29 CFR 1926, Subpart P; Appendices A and B.
 - 2. Comply with minimum requirements for shoring and bracing in accordance with OSHA 29 CFR 1926, Subpart P; Appendix C.
- C. Verify that fill materials submittals have been accepted by the Architect/Engineer before commencing with work requiring the use of these materials.
- D. Verify that erosion and sediment control measures are in place and functioning properly before commencing with work.
- E. Immediately notify the Construction Manager if unexpected subsurface facilities or suspected potentially contaminated materials are encountered during excavation. Discontinue affected work in area until notified to resume work.

F. Test Pits (Test Holes):

1. Comply with the requirements specified in Section 023219.
2. Excavate test pits to field verify the locations of existing underground utilities at crossings and at tie-in points before ordering materials or commencing excavation. Immediately notify the Construction Manager if conflicts are encountered.

3.02 PREPARATION

- A. Underpin adjacent structures that could be damaged by excavation work.
- B. Cut asphalt or concrete with saw or pneumatic tools to prevent damage to pavement to remain. Dispose of large pieces of demolished pavement before proceeding with excavation.
- C. Remove subsurface structures and related obstructions as indicated.
- D. Remove boulders, rock, or reinforced concrete structures within excavation limits or interfering with installation foundation piling.

3.03 PROTECTION OF IN-PLACE CONDITIONS

- A. Comply with the requirements specified in Section 011414.
- B. Support and protect from damage: structures, existing pipes, utilities, utility services, poles, wires, fences, curbs, property line markers, street appurtenances and other features or structures that are to remain in place.
- C. Determine the location of surface and subsurface structures and utilities within the work site. Contractor shall submit a plan to the Construction Manager for approval, detailing the proposed methods of excavating around the existing structures and utilities, and the proposed methods of protecting and supporting the existing structures and utilities. Protect and support structures and utility facilities encountered. Notify the Construction Manager and the Utility three (3) days before crossing any existing utilities, so that the Utility may send a representative to the work site at the time of excavation or construction.
- D. If utilities need to be supported or protected, submit a plan to the Utility for approval that includes the method of support or protection to provide uninterrupted service. At least 5 days before beginning the work, provide a copy of the plan and the Utility's approval to the Construction Manager. Protect and support utilities according to the approved plan.
- E. Protect pavement from damage. Repair damaged pavement to the satisfaction of the Construction Manager.
- F. Excavation Near Existing Structures:

1. Discontinue excavating by machinery when excavation approaches pipes, conduits, utilities, or other underground structures. Continue excavation by use of hand tools. Include such manual excavation in work to be done when incidental to normal excavation and under items involving normal excavation.
2. Excavate test pits near, or at intersection with, existing utilities or underground structures to determine the exact location of existing features as specified in Section 023219.

G. Excavation Near Private Property:

1. Before excavating, record existing condition of features on adjacent properties as specified in Section 023214.
2. Enclose uncut tree trunks adjacent to work in wooden boxes of such height necessary to protect tree from injury due to piled material, equipment, or operations. Operate excavating machinery and cranes so as to prevent injury to overhanging branches and limbs.
3. Protect cultivated hedges, shrubs, and plants that would otherwise be damaged by the Work.
4. Where protection of vegetation is not possible, dig up, temporarily transplant, and maintain. After active construction operations in the area have ceased, transplant vegetation to the original positions and provide water and nursery care until growth is re-established.

3.04 RESTORATION

- A. Promptly restore private property and structures damaged by the Contractor's actions. Begin restoration work within 24 hours of when damage occurred.
- B. If construction activities damage a utility, including service connections, immediately notify the Utility and the Construction Manager.
- C. Existing surfaces, features, or utilities that are to remain that are damaged during construction shall be repaired or replaced to at least the condition in which they were found immediately before work began but using new materials, unless noted otherwise.
- D. Damaged Trees To Remain: Cut all damaged branches, limbs, and roots smoothly and neatly without splitting or crushing. Neatly trim, cut the injured portions and cover with an application of grafting wax or tree healing paint. Replace damaged trees that subsequently die or continue to show lack of growth due to damage one (1) year after substantial completion.

- E. Cultivated Vegetation: Includes, but is not limited to: hedges, shrubs, and plants. Vegetation that is damaged shall be replaced with equal kind and of at least the quality before work began.
- F. For utility trenches, restore disturbed areas to original conditions, the conditions specified in the Contract Drawings, or as directed by the Construction Manager.

3.05 EXCAVATION

- A. Contractor shall follow all OSHA requirements for trenching and excavation.
- B. Excavate to accommodate new structures, utilities and construction operations.
- C. Excavate to lines and grades necessary to provide finish grades.
- D. Establish limits of excavation to allow adequate working space for installing forms and for safety of personnel.
- E. Carry out program of excavation, dewatering, and excavation support systems to eliminate possibility of undermining or disturbing foundations of existing structures and other facilities to remain, or the work.
- F. Provide dewatering system in accordance with Section 312319.
- G. Comply with the requirements of Section 315000.
- H. Preserve material below and beyond the lines of excavations.
- I. Locate stockpiled excavated material at least 3 feet from edge of excavations to prevent cave-ins or bank slides.

3.06 SUBGRADE PREPARATION

- A. The exposed surface shall be examined by the Construction Manager to determine that the proper bearing material has been exposed.
- B. If the Construction Manager determines that the bottom of the excavation is unstable, undercut as directed and backfill and compact. For the resist structure and embankments, backfill with structural fill and compact. For utility trenches, backfill with Dense Graded Aggregate (DGA) and compact. For trenches for water mains in Jersey City, backfill with $\frac{3}{4}$ inch coarse aggregate.
- C. For embankments, compact subgrade and proof roll to identify soft spots or other deficiencies prior to filling operations. Correct deficiencies as specified for Paragraph 3.07 “AUTHORIZED OVER-EXCAVATION” and repeat proof roll procedure until successful. Proof roll equipment shall be in accordance with Paragraph 1.06D.

- D. Proof roll foundation subgrade prior to filling operation or placing foundation concrete. Continue until successful proof test is attained.
- E. For pile supported structures, utilize hand operated equipment to develop a compact dry, stable in-situ soil subgrade. Replace all soft spots or other deficiencies with structural fill, and recompact to 90% Modified Proctor prior to constructing the stabilization slab.

3.07 AUTHORIZED OVER-EXCAVATION

- A. If proof roll test fails in accordance with Paragraph 3.06.C then remove unsuitable material plus an additional 6 inches, and backfill with structural fill.

3.08 UNAUTHORIZED EXCAVATION

- A. Contractor shall backfill unauthorized excavations and over excavations with structural fill and compact at no additional cost to the Owner.

3.09 FILL

- A. Fill to lines and grades necessary to provide finish grades.
- B. Use a placement method that does not disturb or damage other work or existing features to remain. Symmetrically place backfill on each side of pipes.
- C. Maintain fill materials within 3 percent of optimum moisture to attain required compaction density.
- D. Place and compact material in equal continuous layers.
- E. General fill may be used in open areas, as permitted for utility trenches, and in areas that are not load bearing. General fill may not be used for embankments.
- F. Use structural fill beneath and adjacent to buildings and structures.
- G. Use structural fill where footing bearing surfaces are over-excavated or footing is otherwise not bearing on undisturbed soil.
- H. Use structural fill for embankments or in areas designated for future embankments.
- I. Use structural fill for backfill of retaining walls and structures.
- J. Maximum loose lift thickness is 6 inches for aggregate materials and 8 inches for soil materials, unless noted otherwise.
- K. Deposit material evenly around structure to avoid unequal soil pressure.

- L. Do not place backfill against or on structures until the forms have been stripped as specified in Section 031000 and the concrete has attained the strength specified in Section 033000.
- M. In pipe trenches where bedding is not required or other backfill materials specified, backfill with suitable excavated material that is free from rock larger than 2 inches in diameter.
- N. CLSM may be used as alternate backfill for utility trenches as approved by the Construction Manager and the Utility. Do not use CLSM to replace base course or other layers of the pavement structure. Do not combine other backfill materials in the same trench as CLSM. Place CLSM in a manner so as to minimize handling. Place CLSM according to the limitations specified for concrete in Section 033000. Protect as specified for concrete in Section 033000.

3.10 COMPACTION

- A. For utility trenches, manholes and vaults, compact each lift as specified in Table 312300-4. If an area is inaccessible to the compacting equipment listed in the table, compact each lift based on compaction density as specified below.

Table 312300-4		
Embankment Material	Equipment	Passes Per Lift
Sand, Sand and Gravel	Pneumatic-Tired Roller Dynamic Compactor	5 minimum Number of passes to optimize density
Silt, Clay	Pneumatic-Tired Roller Padfoot Roller	5 minimum 8 minimum
Rock	3-Wheel 10-Ton Roller Dynamic Compactor (Vibratory roller with 6-ton min. static weight at drum)	4 minimum 2 to 5

- B. Compaction Density: At other locations, compact to density specified and indicated for various types of material. Control moisture content of material being placed as specified, or if not specified, at a level slightly lower than optimum.
- C. Provide densities in Table 312300-5. The values listed are minimum percentages, unless noted otherwise.

Table 312300-5	
Area	Percentage of Maximum Dry Density as defined by ASTM D1557 (Modified Proctor)
Scarified subgrades	90
Under pavement, slabs	95
Utility trenches	95
Under structures or within 25 feet of structures	95
Under exterior concrete slab and sidewalks	90
Open or grassed areas	85
Topsoil	85 (maximum)

3.11 EMBANKMENT FILL AND COMPACTION

- A. Begin filling in lowest section of work area. Grade surface of fill approximately horizontal but provide with sufficient longitudinal and transverse slope to allow for runoff of surface water from every point.
- B. Install temporary dewatering sumps in low areas during filling operation where excessive amounts of rain runoff collect.
- C. Reduce moisture content of fill material, if necessary, in source area by aerating it during warm and dry atmospheric conditions. A large disc harrow with 2-to-3-foot diameter disks may be required for working soil in a drying operation.
- D. Compact uniformly throughout. Keep fill surfaces sufficiently smooth and free from humps and hollows to allow for proper and uniform compaction. Do not permit hauling equipment to follow a single track on the same layer but direct equipment to spread out to prevent over compaction in localized areas. Take care in obtaining thorough compaction at edges of fill.
- E. Slightly slope surface of fill to ensure drainage during periods of wet weather. Do not place fill while rain is falling or after rain until the Construction Manager considers conditions satisfactory. During such periods and upon suspension of filling operations for periods in excess of 12 hours, roll smooth the surface of fill using a smooth wheel static roller to prevent excessive absorption of rainfall and surface moisture. Prior to resuming compaction operations, remove muddy material off surface to expose firm, compacted material, as determined by the Construction Manager.
- F. When fill is placed against an earlier fill or against in-situ material under and around structures, including around piping beneath structures or embankments, slope junction between two (2) sections of fill at 1.5 to 1 (horizontal to vertical). Bench edge of existing

fill 24 inches to form a serrated edge of compact stable material against which to place the new fill. Ensure that rolling extends over junction between fills.

- G. Clean debris, remove loose material, and proof roll previously placed fill that has become desiccated or littered with debris.
- H. After spreading each loose lift to the required thickness and adjusting its moisture content, roll with sufficient number of passes to obtain the required compaction. One pass is defined as the required number of successive trips, which by means of sufficient overlap will insure complete coverage and uniform compaction of an entire lift. Do not make additional passes until previous pass has been completed.
- I. Fill surface shall be firm and hard when rolled. Reduce moisture content when fill material sinks and weaves under rollers and equipment. Spread out rolling operations over the maximum practicable area to minimize condition of sinking and weaving. Suspend fill operations on portions of embankment where inundations produce surface cracks.
- J. Remove material that fails testing requirements and replace work.

3.12 INSTALLATION OF MISCELLANEOUS MATERIALS

A. Storage gravel:

- 1. Storage gravel aggregate shall be placed in lifts and compacted using plate compactors. Place aggregate in 6-inch maximum loose lifts. Prevent natural or fill soils from intermixing with the aggregate. All contaminated aggregate must be removed and replaced with uncontaminated aggregate. Following aggregate placement, the geotextile fabric must be folded over the stone aggregate to form a 12-inch minimum longitudinal overlap. When overlaps are required between rolls, the upstream roll should overlap a minimum of 2 feet over the downstream roll.
- 2. Voids between geotextile and excavation sides must be avoided. Removing boulders or other obstacles from trench walls is once source of such voids. Natural soils should be placed in these voids during construction to ensure geotextile conformity to excavation sides.

B. Choker Course: Install in accordance with the Contract Drawings.

C. Permeable Aggregate Base:

- 1. Construct the graded aggregate base course on a previously constructed subbase course, as indicated. Provide line and grade stakes for control. Place grade stakes in lanes parallel to the centerline of areas to be paved and space for string lining or other control methods. The base course shall consist of aggregate processed, deposited, spread, and compacted on a prepared surface. The Contractor shall be

responsible for protection of completed areas against detrimental effects. Recondition, reshape, and recompact areas damaged by freezing, rainfall, or other weather conditions.

2. Do not dump mixed materials in piles, but place on prepared subbase in layers of uniform thickness with a spreader. When a compacted course 6 inches in thickness is required, place material in a single layer. When a compacted course in excess of 6 inches is required, place material in layers of equal thickness. Do not exceed 6 inches or have less than 3 inches in thickness for any compacted layer. Place layers so that when compacted, they will be true to grades or levels required with the least possible surface disturbance. Where the base course is constructed in more than one layer, clean previously constructed layers of loose and foreign matter. Maintain material water content during the placing period to obtain the compaction specified. Make adjustments in placing procedures or equipment to obtain true grades, to minimize segregation and degradation, to reduce or increase water content, and to insure a satisfactory base course.
3. Aggregate base shall be moisture conditioned to within 3 percent of optimum moisture content, spread in uniformly thick layers and compacted. The loose thickness and the surface of the layer shall be such that the specified density and the required thickness shall be obtained after compaction. Compact the layer with steel-faced, vibrating or pneumatic-tired rollers, or other suitable compacting equipment or combinations thereof. Continue compacting until the layer is compacted through the full depth to a field density of at a minimum of 95 percent of the ASTM D 1557 maximum density. In areas not accessible to rollers or compactors, compact the mixture with mechanical hand tampers. If the mixture is excessively moistened by rain, aerate by blade graders, or other suitable equipment. Aerate until the moisture content of the material is that needed to obtain the required density. Finish the surface of the layer by a combination of rolling and blading. Final surface shall be smooth and free from waves, irregularities, and ruts or soft yielding spots.
4. In addition to compacting the base course to the required density, proof roll the top surface of the completed base course by making eight coverages with a heavy rubber-tired roller having four tires with each tire loaded to 30,000 pounds or more and inflated to at least 150 psi. Make four coverages over other areas to be paved. A coverage is defined as one application of one tire print over each point in the surface of the designated area. When under the action of the proof rolling, the base course yields, pumps, or otherwise fails, remove, replace with suitable materials, and recompact materials in the base course or in the underlying layers indicated to be unsatisfactory. The speed of the roller shall not exceed 5 miles per hour. Obtain approval upon completion of the proof rolling of the base course.
5. Place earth or other approved materials along the edges of the base course in such quantity that it will compact to the thickness of the course being constructed. When

the course is being constructed in two or more layers, place material to the thickness of each layer. In each operation, allow at least a one-foot width of the shoulder to be rolled and compacted simultaneously with the rolling and compacting of each layer.

- D. Drainage Backfill: Install in accordance with the Contract Drawings.
- E. Riprap: Install in accordance with the Contract Drawings.
- F. Filter Sand: Install in accordance with the Contract Drawings.
- G. Geotextile Fabric: Install in accordance with the Contract Drawings.
- H. Impermeable Liner: Install in accordance with the Contract Drawings.

3.13 FIELD QUALITY CONTROL

- A. The Contractor's Independent Testing Laboratory shall conduct inspection and testing to verify the work meets the specified quality.
- B. The testing agency shall maintain a qualified representative on site during compaction and testing operations. Perform inspection at least once daily to confirm each lift thickness and compaction effort for entire fill area.
- C. Perform particle size distribution and gradation analyses using ASTM D422 and following standard practices in ASTM D421. Perform one (1) test for every source and material and submit results to Construction Manager for acceptance. Repeat the moisture density test for every 250 cubic yards of material used.
- D. Perform field density testing in accordance with ASTM D1556, ASTM D2167, or ASTM D6938.
- E. Evaluate field density test results in relation to maximum dry density as determined by testing material in accordance with ASTM D1557 (Modified Proctor).
- F. Perform tests in accordance with ASTM D4318 to determine Liquid Limit, Plastic Limit and Plasticity Index and submit test results to Construction Manager for acceptance. Minimum of one (1) test per 250 cubic yards of soil for use as fill material and whenever classification of material is in doubt as determined by the Construction Manager.
- G. Location of field density tests shall be mutually acceptable to testing laboratory and Construction Manager.
- H. In the event compacted material does not meet specified in-place density, re-compact material and re-test area until specified results are obtained.

I. Perform field density tests at the frequency specified in Table 312300-6:

Table 312300-6	
Area	Frequency
Resist Footing and Wall Backfill	1 per alternate lift for each 50 linear feet (both sides of wall)
Roadways, Paved Areas and Utility Trenches	1 per lift for each 500 cubic yards of fill placed
Open Areas	1 per lift for each 750 cubic yards of fill placed
Regardless of the minimum testing frequency specified, field density tests shall be performed by the Contractor in sufficient number for the Contractor's quality control purposes to ensure that specified density is obtained.	

3.14 ADJUSTING

A. Shrinkage:

1. Build embankments or backfill to a height above finished grade that will allow for the shrinkage or consolidation of material. Initially, provide at all points, an excess of at least 1 percent of total height of backfill measured from original grade to top of finished surface.
2. Backfill with specified materials to build up low places when embankment or backfill settles below the finished grade at any time before substantial completion.

3.15 TOLERANCES

- A. For utility trenches, construct finished surfaces to plus or minus ¼ inch of the surrounding grade.
- B. Construct other finished surfaces to plus or minus 1/2 inch of the elevations indicated.
- C. Grade areas of cut and fill to plus or minus 0.20 foot of the grades indicated.
- D. Complete embankment edges to plus or minus 6 inches of the slope lines indicated.
- E. Provide the Construction Manager with adequate survey information to verify compliance with above tolerances.

3.16 PROTECTION

- A. Formulate excavation, backfilling, and filling schedule and procedures to eliminate possibility of undermining or disturbing foundations of partially and completed structures, utilities, pipelines and embankments or existing structures, utilities, and pipelines.

3.17 CONTRACT CLOSEOUT

- A. Provide in accordance with Section 017700.

END OF SECTION 312300

NO TEXT ON THIS PAGE

SECTION 312319 - DEWATERING

PART 1 - GENERAL

1.01 DESCRIPTION

- A. Provide dewatering as indicated and in compliance with Contract Documents.
- B. Design, furnish, operate, maintain, and remove temporary dewatering systems to control groundwater and surface water to maintain stable, undisturbed subgrades, and permit work to be performed under dry and stable conditions. Work to be done as part of dewatering includes, but is not limited to:
 - 1. Lower the groundwater level.
 - 2. Lower hydrostatic pressure.
 - 3. Prevent surface water from entering the excavation during construction.
 - 4. Implement erosion control measures for disposing of discharge water.
 - 5. Provide groundwater recharging systems as specified and as indicated. Provide and monitor observation wells and other geotechnical instrumentation in accordance with Section 310930.
- C. Groundwater within the excavation area shall be lowered to at least 2 feet below the lowest excavation levels or as specified and as indicated.
- D. Common dewatering methods include, but are not limited to, sump pumping, deep wells, well points, vacuum well points, or combinations thereof.
- E. Common groundwater recharge methods include, but are not limited to, deep wells, large sumps, or combination thereof.
- F. The Contractor shall obtain the required permits for discharge from the Contractor's dewatering systems in accordance with the New Jersey Water Pollution Control Act (N.J.S.A. 58:10A-1 et seq), the New Jersey Water Supply Management Act (N.J.S.A. 58:1A-1 et seq), the Federal Clean Water Act, and utility authorities. The discharge location shall be in accordance with permit requirements.

1.02 PAYMENT

- A. No separate payment shall be made for performing any Work required under this Section. All costs for Work required by this Section shall be included in the applicable lump sum, unit price(s), or allowance(s) as set forth in Section 012901.

1.03 REFERENCES

- A. Code of Federal Regulations, Title 40 – Protection of Environment (CFR):
 - 1. 40 CFR Part 122: EPA Administered Permit Programs: The National Pollutant Discharge Elimination System.
- B. New Jersey Pollutant Discharge Elimination System (NJPDES) Rules at N.J.A.C 7:14A.
- C. New Jersey Treatments Works Approval N.J.A.C. 7:14A-22 and 23.
- D. New Jersey Water Supply Management Act Rules (N.J.A.C. 7:19-6).

1.04 RELATED SECTIONS

- A. General Conditions Article 4.7 – Shop Drawings and Other Submittals
- B. Section 012901 – Measurement and Payment
- C. Section 013443 – Environmental Procedures
- D. Section 014300 - Quality Assurance.
- E. Section 016100 – Control of Materials.
- F. Section 017700 - Contract Closeout.
- G. Section 021600 – Excess Clean Fill, Contaminated Soil, and Groundwater Management and Disposal
- H. Section 310930 – Geotechnical Instrumentation
- I. Section 312300 - Excavation and Fill.

1.05 SUBMITTALS

- A. Submit the following in accordance with General Conditions Article 4.7.
- B. Qualification for the Contractor’s dewatering specialist's or firm's qualifications, a minimum of four (4) weeks prior to the start of any dewatering work. The submittal shall include, but not be limited to:
 - a. Qualifications of specialist's or firm's Registered Professional Engineer.
 - b. Qualifications of specialist's or firm's field representative who will oversee the installation, operation and maintenance of the dewatering system.

2. Submit a dewatering plan, a monitoring plan and, if applicable, a groundwater recharge plan at least two (2) weeks prior to start of dewatering work. The review will be only for the information of the Construction Manager and third parties for an overall understanding of the Project relating to access, maintenance of existing facilities and proper utilization of the site. The Contractor shall remain responsible for the adequacy and safety of the means, methods and sequencing of construction. The plan shall include the following items as a minimum:
 - a. Dewatering plan showing the arrangement and locations of discharge lines, means of discharge and disposal, and other details stamped and signed by a Registered Professional Engineer registered in the State of New Jersey.
 - b. Certificate of Design: Refer to Section 014300.
 - c. A list of equipment including, but not limited to, pumps, prime movers, and standby equipment.
 - d. Detailed description of dewatering, maintenance, and system removal procedures.
 - e. Monitoring plan and details shall be signed by a Registered Professional Engineer registered in the State of New Jersey. The plan shall include, but not limited to, number and locations of observation wells, geotechnical instruments) and piezometers with the frequency of reading for each monitoring device, in accordance with Section 310930.
 - f. Erosion and sedimentation control measures, and methods for disposal of pumped water.
 - g. List of all applicable laws, regulations, rules, and codes to which dewatering design conforms.
 - h. List of assumptions made for design of dewatering and for groundwater recharge systems, including but not limited to groundwater levels, soil profile, permeability, and duration of pumping and/or recharge.
 - i. Detailed description of methods used to limit amount of water generated during dewatering operations. The Contractor shall be prepared to implement different methods to limit the amount of water generated depending upon site conditions, which may vary at different locations within the work area.
3. Measurement records consisting of observation well groundwater records and the geotechnical instrumentation readings within one (1) day of monitoring.
4. A modified dewatering plan within 24 hours, if open pumping from sumps and ditches results in boils, loss of fines or softening of the ground.

1.06 QUALITY ASSURANCE

- A. Comply with the requirements specified in Section 014300.
- B. Contractor shall employ the services of a dewatering specialist or firm having the following qualifications:
 - 1. Completed at least five (5) successful dewatering projects of equal size and complexity and with equal systems within the last five (5) years.
 - 2. Retain the services of a Registered Professional Engineer in the State of New Jersey having a minimum of five (5) years' experience in the design of well points, deep wells, recharge systems, or equal systems.
 - 3. Retain the services of a field representative having a minimum of five (5) years' experience in installation of well points, deep wells, recharge systems, or equal systems.
- C. If subgrade soils are disturbed or become unstable due to dewatering operations or an inadequate dewatering system, notify the Construction Manager immediately, stabilize the subgrade, and modify system to perform as specified.
- D. Notify the Construction Manager immediately if settlement or movement is detected on structures or roadways. If the settlement or movement is deemed by the Construction Manager to be related to the dewatering, take actions to protect the adjacent structures and roadways and submit a modified dewatering plan to the Construction Manager within 24 hours. Implement the modified plan and repair damage incurred to adjacent structures and roadways.
- E. Immediately notify the Construction Manager if oil or other hazardous materials are encountered before or during dewatering operations.

1.07 HYDRAULIC UPLIFT OF STRUCTURES

- A. The Contractor shall be responsible for the protection of all structures against hydraulic uplift until such structures have been accepted by the Construction Manager.

1.08 PRECAUTIONS AGAINST HYDROSTATIC UPLIFT DURING CONSTRUCTION

- A. The Contractor shall maintain a low groundwater elevation in the vicinity of the any structures under construction until completed. In case of extremely highwater during construction of a structure, it may be necessary to flood the structure to maintain stable conditions.

1.09 DELIVERY, STORAGE AND HANDLING

- A. Comply with the requirements specified in Section 016100.

1.10 SITE CONDITIONS

- A. Subsurface Conditions: Refer to the Geotechnical Investigations Results Report and the Soil profile as part of the Contract Drawings.

PART 2 - PRODUCTS

2.01 MATERIALS

- A. Provide settlement markers, piezometers and other geotechnical instruments in accordance with the approved dewatering plan or as specified in Section 310930.
- B. Provide casings, well screens, piping, fittings, pumps, power, and other items required for dewatering system.
- C. Provide sand and gravel filter around the well screen. Wrapping geotextile fabric directly around the well screen shall not be permitted.
- D. When deep wells, well points, or vacuum well points are used, provide pumping units capable of maintaining high vacuum and handling large volumes of air and water at the same time.
- E. Provide auxiliary dewatering equipment in the event of breakdown. Equipment shall consist of pumps and hoses and be stored on site. Provide at least one (1) additional pump for every five (5) pumps used in the dewatering system.
- F. Provide and maintain erosion and sedimentation control devices as indicated or specified and in accordance with the approved dewatering plan.
- G. Provide temporary pipes, hoses, flumes, or channels for the transport of discharge water to the discharge location.
- H. Provide pipe, hoses or channel protections, in areas that can encounter pedestrian traffic as indicated or specified and in accordance with the approved dewatering plan.
- I. Provide cement grout having a water cement ratio of 1 to 1 by volume.

PART 3- EXECUTION

3.01 INSTALLATION

- A. Execution of earth excavation, installing earth retention systems, and dewatering shall not commence until the related submittals have been reviewed by the Construction Manager with all Construction Manager's comments satisfactorily addressed with the geotechnical instrumentation monitoring plan implemented.
- B. Provide and maintain dewatering system in accordance with the approved dewatering plan.
- C. Carry out dewatering program in such a manner as to prevent undermining or disturbing foundations of existing structures, roadways, or work ongoing or previously completed.
- D. Do not excavate until the dewatering system is operational.
- E. Unless otherwise specified, continue dewatering uninterrupted until all structures, pipes, and appurtenances below groundwater level have been completed such that they will not be floated or otherwise damaged by an increase in groundwater elevation.
- F. Discontinue open pumping from sumps and ditches when such pumping results in boils, loss of fines, softening of the ground, or instability of the slopes. Modify dewatering plan and submit revised plan to the Construction Manager for acceptance.
- G. Where subgrade materials are disturbed or become unstable due to dewatering operations, remove and replace the materials in accordance with the Contract Sections.
- H. Dewatering Discharge:
 - 1. Install and monitor recharge systems in accordance with the approved dewatering plan.
 - 2. Install sand and gravel filters in conjunction with well points and deep wells to prevent the migration of fines from the existing soil during the dewatering operation.
 - 3. Transport pumped or drained water to discharge location without interference to other work, damage to pavement, other surfaces, or property.
 - 4. Provide separately controllable pumping lines.
 - 5. The Construction Manager reserves the right to sample discharge water at any time.

6. Immediately notify the Construction Manager if suspected contaminated groundwater is encountered. Do not pump water found to be contaminated with oil or other hazardous material to the discharge locations.

I. Monitoring Devices and Records:

1. Install, maintain, monitor, and take readings from the observation wells and geotechnical instruments in accordance with the approved dewatering plan.
2. Install settlement markers on structures within the zone of influence for dewatering a distance equal to twice the depth of the excavation, from the closest edge of the excavation. Conduct and report settlement surveys to 1/8-inch.
3. For linear excavations such as trenches, the zone of influence for dewatering shall be 30 feet.
4. For large rectangular, square, or circular mass excavations, the zone of influence shall be defined by the actual cone of watering influence corresponding to a 10 percent increase in effective vertical stress.

J. Install and maintain erosion/sedimentation control devices at the point of discharge as indicated or specified and in accordance with the approved dewatering plan.

K. Removal:

1. Do not remove dewatering system without written acceptance from the Construction Manager.
2. Backfill and compact sumps or ditches with screened gravel or crushed stone wrapped with geotextile fabric in accordance with Section 312300.
3. All dewatering wells shall be abandoned upon completion of the work and completely backfilled with cement grout, in accordance with permits

3.02 CONTRACT CLOSEOUT

- A. Provide in accordance with Section 017700.

END OF SECTION 312319

NO TEXT ON THIS PAGE

SECTION 313236 - JET GROUTING

PART 1 - GENERAL

1.01 DESCRIPTION

- A. Requirements for furnishing all labor, equipment, and materials necessary for installing ground water cut-off walls utilizing jet grouting and all associated testing, monitoring, sampling and recording required for installing the jet grouting as specified herein. A jet grouting program shall be submitted for approval to the Construction Manager, including a plan for execution of the work and all supporting data or calculations to support the plan. Jet grouting is to be provided in areas shown on the Contract Drawings.
- B. The Contractor shall be responsible for installing and monitoring instrumentation on existing structures during all jet grouting operations.

1.02 PAYMENT

- A. No separate payment shall be made for performing any Work required under this Section. All costs for Work required by this Section shall be included in the applicable lump sum(s), unit price(s), or allowance(s) as set forth in Section 012901.

1.03 DEFINITIONS

- A. Monitor: A tool designed to convey the elements of the jet grouting process: air, water and/or grout. The monitor has one (1) or more injection points. The cutting action of the erosion jet(s) is enhanced by surrounding it within a concentric collar of compressed air (double and triple fluid systems).
- B. Jet Grouting: The process of creating stabilized soil-cement columns in place utilizing a grout mix delivered at high pressure through a special drill bit that has high velocity horizontal jets.
- C. This process produces soil-cement columns by pumping a neat cement grout slurry through horizontal jets which cuts and mixes in-situ with the surrounding soil materials as the drill bit is slowly rotated and withdrawn.

1.04 REFERENCES

- 1. Unless otherwise noted, the latest edition of the following codes, standards, and publications shall govern the work under this Section. If any conflicts exist between these codes, standards, and publications the more restrictive requirements shall govern. American Petroleum Institute (API).
 - a. API 13A (2019) Drilling Fluid Materials.

2. American Society for Testing and Materials (ASTM)
 - a. ASTM C150 Standard Specification for Portland Cement.
 - b. ASTM C494 Standard Specification for Chemical Admixtures for Concrete.
 - c. ASTM D1633 Compressive Strength of Molded Soil-Cement Cylinders.
 - d. ASTM D2113 Rock Core Drilling and Sampling of Rock for Site Investigation.
 - e. ASTM D2166 Standard Test Method for Unconfined Compressive Strength of Cohesive Soil.
 - f. ASTM D2850 Standard Test Method for Unconsolidated-Undrained Triaxial Compression Test on Cohesive Soils.
 - g. ASTM D4138 Standard Practices for Measurement of Dry Film Thickness of Protective Coating Systems by Destructive Cross-Sectioning Means
 - h. ASTM D4380 Standard Test Method for Density of Bentonitic Slurries.
 - i. ASTM D5079 Preserving and Transporting Rock Core Samples.
 - j. ASTM D5084 Measurement of Hydraulic Conductivity of Saturated Porous Materials Using a Flexible Wall Permeameter.

1.05 RELATED SECTIONS

- A. General Conditions Article 4.7 – Shop Drawings and Other Submittals
- B. Section 012901 – Measurement and Payment
- C. Section 014300 – Quality Requirements
- D. Section 016100 – Control of Materials
- E. Section 017700 – Contract Closeout

1.06 SUBMITTALS

- A. Submit the following in accordance with General Conditions Article 4.7.
 1. Qualifications for the Contractor's, specialty subcontractor, consulting firm, shall submit detailed qualifications, a minimum of four (4) weeks prior to the commencement of any jet grouting operations. The submittal shall include but not limited to:

- a. Qualifications of specialty subcontractor or consulting firm's Registered Professional Engineer.
 - b. Experience in performing jet grout columns within low head areas, and at least five (5) years of prior experience performing similar projects.
 - c. Qualifications of specialty subcontractor or consulting firm's field representative who will oversee the jet grout operation.
 - d. Experience and training records of all operators and on-site supervisor's who will be performing jet grouting operations. The experience shall be specific to the type of grouting method and equipment being utilized by the Contractor. The operator and on-site supervisor must have a minimum of two (2) years' experience. The supervisor shall be present on-site, at all times during jet grouting operations.
2. A detailed jet grout program work plan shall be submitted at least two (2) weeks prior to start of the jet grouting operations. The plan shall include, but not limited to:
- a. The proposed grouting method.
 - b. A list of equipment including, drill rigs, pumps, mixers, etc.
 - c. Certificate of Design, in accordance with Section 014300.
 - d. List of all applicable laws, regulations, rules, and codes to which jet grouting design conforms.
 - e. Quality Assurance-Quality Control Program Plan.
 - f. A description of the Quality Assurance-Quality Control Program Plan.
 - g. Example formats of Daily Production Reports meeting the requirements stated herein.
 - h. A detailed description of all tests means and methods proposed by the Contractor to verify that columns meet the specified compressive strength and permeability requirements.
- B. Submit the following Shop Drawings in accordance with General Conditions Article 4.7.
1. Jet Grouting shop drawings shall be submitted at least two (2) weeks prior to jet grouting operations, including sequence and time schedule of the jet grouting operations. Drawing locations of the jet grouting shall be shown on a drawing

not smaller than 1 inch = 10 feet scale to show the details of the layout required to satisfy the geometries required. The drawings shall include the following:

- a. Plant, equipment and material descriptions. Equipment, procedures, and materials to be used for jet grouting. Include catalog cut sheets of: jet grouting equipment with dimensions and capacities of equipment and components; cement grout mixing equipment; pumps; jet grouting monitoring systems; pipelines; control equipment; and hoses and pumps.
- b. Arrangement of grout mixing and injection equipment, location of boreholes, and other necessary details.
- c. Methods for drilling and supporting boreholes.
- d. Grout mix design, sources of mix materials, and material data demonstrating compliance with the specified mix material described herein.
- e. Layout and procedures for test program to establish jet grouting parameters, including sampling and testing to determine quality and properties of grout materials.

C. Product Data:

1. Description of method(s) and equipment to be used to penetrate the existing ground conditions and to install the grout.
2. Include details and catalog-cut sheets and all ancillary equipment.
3. Design Mix shall be submitted at least two (2) weeks prior to the start of jet grouting operations, proportions and properties of the proposed design mix including cement, bentonite, additives, and water proportions; viscosity, density, unconfined compressive strength, and permeability shall be included to the Construction Manager for review and approval. Either a new project-specific laboratory design mix program or the results of previous laboratory test programs (as long as the materials are similar to those proposed for this Project) are acceptable.
4. Test Reports:
 - a. Metering Equipment
 - b. Calibration test results for metering equipment.
 - c. As-Built Field Measurement Data

- d. A log of the installation of each column shall be prepared by the Contractor and submitted to the Construction Manager within one (1) day of installation. The log shall contain the information listed herein.

1.07 PERFORMANCE REQUIREMENTS

- A. The Contractor shall install jet grout columns at the locations and configurations as shown on the Contract Drawings and specified herein, meeting the acceptance criteria defined in Paragraph 3.05 "ACCEPTANCE CRITERIA".

1.08 QUALITY ASSURANCE

- A. Comply with the requirements specified in Section 014300.
- B. Employ the services of a specialty contractor having the following qualifications:
 1. Retain services of a Registered Professional Engineer in the State of New Jersey having a minimum of five (5) years' experience in the design of grout mixtures.
 2. Established record of at least five (5) years' experience in performing similar jet grouting operations including a successful jet grout cut-off wall installation with the same equipment as proposed.
 3. Provide detailed information on the training and experience of any jet grout operators with less than five (5) years' experience for approval by the Construction Manager; but in no case shall any operator have less than two (2) years of experience in the installation of jet grout cut-off walls.
 4. Provide a site superintendent and/or construction manager with a minimum of two (2) years' experience in jet grout cut-off wall installation. The core drill operator shall have at least two (2) years' experience coring jet grout or soil cement mixtures.
- C. The Contractor shall not commence work until the Construction Manager has approved the Contractor, the supervisor, and the jet grouting program and shall provide an experienced, full-time supervisor who has been in responsible charge of supervising jet grouting operations for at least two (2) years. The supervisor shall be present at the work site at all times during jet grouting operations.

1.09 GENERAL JET GROUTING

- A. The Contractor shall implement a Quality Assurance-Quality Control Program Plan to permit the confirmation that the ground treatment methods performed are applied in accordance with this specification, and approved submittals, sampling and testing of Paragraph 1.08.A.4, and achieve the specified in Paragraph 3.05 "ACCEPTANCE CRITERIA". The Quality Control Plan shall also be implemented to generate and

maintain records of the quality control measures for jet grouting operations including, but not limited to:

1. Equipment. Type, size, and suitability for the construction of the prescribed Work.
2. Materials. Compliance with this specification and approved submittals.
3. Installation.
 - a. Continuous injection, mixing vertically full depth, with computer monitoring.
 - b. Geometric Tolerances. Horizontal alignment of the elements shall be within 2 inches of the planned location as measured at the ground surface. The inclination of the columns (vertical alignment) shall be within 1.0 percent of vertical as measured at the ground surface.
 - c. The width of the columns shall be within ± 1 percent of the column width specified herein.
 - d. Top of grout columns shall be at a minimum to the top elevation shown on the Contract Drawings.
 - e. Bottom of grout columns shall be at a minimum to the tip elevation shown in the Contract Drawings.
4. Sampling and Test Means and Methods
 - a. Tests. Unconfined compression tests and permeability shall be performed for core and wet grab samples. Unconfined compression testing shall be performed in accordance with ASTM D2166. Permeability tests shall be performed in accordance with ASTM D5084.
 - b. Coring. Three (3) percent of the total installed elements shall be cored and tested. Additional coring may be done at the discretion of the Construction Manager, if significant deficiencies are found based on the planned testing. The Construction Manager will select the elements to be cored. Contractor shall perform core sampling of hardened soil-cement, in accordance with ASTM D2113. The core shall be obtained for the full depth of the element. The minimum core recovery shall be 80 percent. Core samples intended for strength tests should be prepared in accordance with the "Special Care" requirements of ASTM D5079, Section 7.5.2, and stored in a moist room or other curing facility. If recovery is lower than required, the Construction Manager may require additional coring at Contractor's expense.

- c. The cores shall be made available for review by the Construction Manager. Contractor shall determine the core recovery for each core run.
- d. For core sampling, the sample diameter shall be at least 3.0 inches or greater and core runs shall be no more than five (5) feet.
- e. Contractor shall grout each core hole with neat cement grout (water cement ratio 1:1) at the completion of each core hole using tremie methods.
- f. The Construction Manager shall select ten (10) core samples from each coring location for strength testing. The test specimens shall have a length to diameter ratio of 2. Unconfined compression tests shall be performed on each core sample at approximately 28 days after column installation.
- g. Wet Grab Samples. No less than two (2) samples per 100 feet of installed column or panel.

5. Specific Gravity

- a. The specific gravity of the grout shall be determined during the validation program for double-checking grout proportions. Contractor shall check the specific gravity of the grout at least twice per shift per rig using the methods outlined in ASTM D4380. The specific gravity measurements shall be indicated on the Daily Quality Control (QC) Report.

6. Other Proposed Test methods

- a. The Contractor may propose other types of tests, or exploration to evaluate quality of the completed elements. Such tests may include down-hole video inspection, sonic testing, Menard Pressure-meter tests, or others. All other proposed testing shall be subject to approval by the Construction Manager.

1.10 REPORTING

- A. The original and two (2) copies of Quality Control testing records, as well as the records of corrective action taken, shall be furnished to the Construction Manager daily.

1.11 WORK PLAN

- A. A detailed work plan describing the proposed grouting methods and equipment to be used. At a minimum the work plan shall include, but not limited to:
 - 1. Jet grouting procedures for supporting the groundwater control at the excavation locations.

2. Provisions to prevent discharge of slurry grout outside of the rights-of-way limits, including potential inadvertent returns and provisions to contain any discharge and mitigate future grout losses, should it occur.
3. Description of grout plant and equipment.
4. Arrangement of grout mixing, recording, and injection equipment, layout of grout columns, and other details to illustrate the plan for setting up each site to be treated.
5. Schedule and sequence for competing jet grouting test columns and production jet grouting work.
6. Layout and designation of jet grout columns for cut-off wall.
7. Grout mix design, sources of mix materials, and admixtures. Grout mix design shall include target range for unit weight, marsh viscosity, and bleed, that will produce desired grout strength. Provide 7 and 28-day design compressive strengths for neat cement grout mix. Submit MSDS sheets for admixtures that may be used.
8. Quality control procedures including record keeping, field testing, sampling, and laboratory testing of completed columns.
9. Grout mix proportions, design, sources of mix materials, and material data, including a daily record of batch quantities and cement dosages and a daily record of spoil handling quantities and weight of spoil disposal. Calculations shall be submitted demonstrating a maximum in-situ diluted water to cement ratio to be accomplished by the mix design and jetting parameters, and a plan to demonstrate in-situ water to cement effectiveness by material balance or other means.
10. Layout and procedures for test program to establish jet grouting parameters, including sampling and testing to determine quality and properties of grout materials.

1.12 SAMPLE LOG

- A. Sample logs shall include:
 1. Project name and number
 2. Wall section number
 3. Machine number.
 4. Type of grouting tool.

5. Date and time of the jet grouting installation.
6. Plant, equipment and material descriptions.
7. Arrangement of grout mixing and injection equipment, location of boreholes, and other necessary details.
8. Methods for drilling and supporting boreholes.
9. Sequence of grouting installation.
10. Grout mix proportions.
11. Grout hole geometry (size, length and location).
12. Time and date of beginning and completion of each grout column.
13. Erosion jet pressures used to construct each grout element.
14. Grout rates and takes for each grout column.
15. Rates of rotation and withdrawal of jet grout monitor for each grout element.
16. Other pertinent observations, such as: grout escapes, ground heave, or other unusual behavior.
17. A description of obstructions or other interruptions of binder injections during installation.

1.13 DELIVERY, STORAGE, AND HANDLING OF MATERIALS

- A. Comply with the requirements specified in Section 016100.

1.14 SITE CONDITIONS

- A. Geotechnical Investigation Results Report: The report is for information only, which is part of the Contract Documents. The boring logs are included as an appendix in the report and indicate subsurface conditions encountered only the borehole location. This report shall not be construed as to guarantee that other subsurface materials will not be present or that proportions of materials will not vary from that shown on the boring logs. The borehole locations and soil profiles are part of the Contract Drawings.
- B. Throughout execution of the jet grouting operations, the Contractor shall take all precautions and measures necessary to safely move and position equipment, support equipment and personnel around the site. It is anticipated that jet grouting may be performed simultaneously with other construction activities. Prior to the jet grouting, the Contractor's site preparation work will have produced a suitable working surface for

the equipment. The Contractor shall provide equipment, materials, cribbing timber mats or other support structures necessary to provide a stable-working surface for the jet grouting.

- C. Granular fill Shall not be used without prior acceptance from the Construction Manager. The Contractor shall be responsible for evaluating and analyzing the jet grouting based on the Contractor's proposed construction sequence and methods.

PART 2 - PRODUCTS

2.01 MATERIALS

- A. Grout: Grout shall be a mixture of Portland cement, water, bentonite and/or other non-toxic, biodegradable admixtures, if required. The grout shall be mixed in a grout plant that combines dry cement and water in predetermined proportions. Grout mixes shall have a consistency that is fluid and pumpable. Grout mixes shall be proportioned to provide the required strength and mixing consistency. The grout mix utilized shall have a maximum water/cement ratio of 1:1 by weight.
- B. Cement: ASTM C150 Portland Type I or Type I-II and/or ASTM C989 Ground Granular Blast Furnace Slag Grade 120 or a mixture of both.
- C. Admixtures: Cement admixtures will not be allowed, without prior submittal showing effect and shall be approved by the Architect/Engineer. Common water treatment additives may be used to correct water quality or enhance bentonite hydration and mixing. These additives may include soda ash, lime, or aluminum. Admixtures of softening agents, dispersants, retarders, or plugging or bridging agents may be added to the water or the slurry to permit efficient use of bentonite and proper workability of the cement bentonite slurry. Retarders, thinners, and accelerators may be used under the direct supervision of the Contractor to correct specific problems. Peptizing or bulking agents will not be permitted for mixing with slurry. When admixtures are used to improve pumpability, to control set time, and to prevent segregation and bleeding, admixtures shall be non-toxic and biodegradable and conform to ASTM C494.
- D. Bentonite: Premium grade, ultrafine, sodium cation based montmorillonite powder (Wyoming type bentonite) that meets or exceeds the requirements of API 13A, Section 9, 2019 edition. Grout mix shall not contain more than 2 percent bentonite, by dry weight of cement or as approved by the Architect/Engineer.
- E. Water: Fresh and potable water shall be used.

2.02 GENERAL EQUIPMENT REQUIREMENTS

- A. All equipment used for drilling boreholes; lowering, raising and rotating jet monitors, mixing grout, supplying pressurized grout and air-water to jet monitors, and jet monitors used to perform the jet grouting for cut-off walls shall have proven performance records

for use in similar work. Spare parts and equipment shall be available on site to maintain jet grouting equipment in satisfactory operation condition during execution of the jet grouting operations.

- B. Drilling Equipment: Use drilling equipment of a type and capacity suitable for drilling required hole sizes and depths, and lowering, raising, and rotating jet grout monitors to the depths and at the rates required to perform the cut-off wall installation for the full range of subsurface conditions described in the Geotechnical Investigations Results Report, shown on the Contract Drawings and as specified herein.
- C. Jet Grouting Monitors: Use jet grouting monitors as described herein having capacity suitable for producing grout elements in subsurface conditions identified in the Geotechnical Investigation Results Report, and of the size and depth shown on the Contract Drawings and as specified herein.
- D. Grout Mixing and Injection Equipment: Use high-speed colloidal shear grout mixer, grout agitator, automatic electronic control unit, and holding tanks, water tanks, air compressors, and pumps of sufficient capacity to ensure adequate supply of grout, air, and water at required pressure to the jet grouting monitors during a full work shift to produce grout columns of the quality and dimensions necessary.
- E. Jet Pumps: Pumps shall be high-pressure pumps capable of delivering the grout at the flow rates and pressures required.
- F. Metering Equipment: Provide automatic recording equipment with a meter to determine the volume of grout injected. The meter shall be calibrated within the past two (2) months to the nearest unit. The grout injection rate recorded by the flow meter shall be verified daily by counting the strokes of the piston pump in a fixed period of time and recorded on grout logs.
- G. Spare Parts: Spare parts and/or equipment shall be available on site to maintain the jet grouting equipment in satisfactorily operating conditions at all times during execution of the grouting work.

PART 3 - EXECUTION

3.01 GENERAL

- A. Damaged Holes: Any jet grout holes lost or damaged as the result of mechanical failure of equipment, inadequacy of grout, air, or water supplies, or improper drilling or injection procedures shall be backfilled with cement grout and replaced by additional jet grout holes that ensure a complete encapsulation of the damaged hole and re-establish a continuous cut-off at no additional cost to the DEP.
- B. Jet Grouting: Jet grout injection and jet monitor rotation and extraction rates shall be sufficient to produce grout columns/panels meeting the diameter, depth, overlap, and

material property requirements specified herein. The required mixing tool rotational speeds and penetration/withdrawal rates for the various subsurface conditions encountered shall be determined during the test section and be used during the balance of the jet grouting operations. If during a column section, these parameters are varied more than 15 percent from those determined during the test section, a replacement of the variant column section shall be installed, at no cost to the DEP. Based upon conditions encountered during production, the Contractor may request that the established mixing parameters be modified during the production column installation, subject to approval of the Architect/Engineer.

- C. Design Mix: Proportion and inject jet grout mix so that the grout column produced meets the Acceptance Criteria Outline in Paragraph 3.05 "ACCEPTANCE CRITERIA".
- D. Equipment: Equipment for mixing, holding, and pumping grout shall be in a secure location and shall be operated to minimize spillage of material. No material will be allowed to enter drainage areas.

3.02 TEST PROGRAM

- A. The Contractor shall construct a test section of the jet-grouted elements in a location near the proposed jet grouting area and approved by the Construction Manager to evaluate the proposed methods and the grout mix's ability to produce grout columns meeting the depth, diameter, overlapping and material property requirements shown on the Contract Drawings and specified herein, prior to starting jet grouting operations. A test section shall be performed at each jet grouting area. Execute test program in accordance with the procedures submitted herein and as approved by the Architect/Engineer.
- B. Test Section Geometrics:
 - 1. Conduct a test program to evaluate the proposed grouting methods and the ability of the proposed grout mix to produce grout columns meeting the depth, diameter, overlap, and material property requirements shown on the Contract Drawings and specified herein.
 - 2. The Contractor shall select a representative location to perform the test program, as approved by the Construction Manager prior to starting the test program.
 - 3. The test program shall be designed to verify the following items:
 - a. The range of column diameters and column strengths which can be achieved.
 - b. The column overlaps and continuity between columns which can be achieved.
 - c. Maximum pressures that can be used before ground surface heave occurs.

4. The test section shall consist of two (2) to three (3) grout columns installed as specified for the production jet grouting operations.
 5. Execute the test program in accordance with the approved submittals. Mixing is to be controlled by shaft rotational speed, drilling speed, and grout injection rate. The Contractor shall expose columns from the test section for physical inspection. Measure the column diameter and compare with the design diameter.
 6. After the jet grout columns have set up sufficiently, obtain a continuous core sample from one (1) of the columns. Inspect the core and check for segregation. Select three (3) samples from the core column and perform compression tests in accordance with ASTM D1633 or ASTM D2850 and permeability tests in accordance with ASTM D5084, or as approved by the Architect/Engineer.
- C. If satisfactory results are not achieved from the test program the Construction Manager may require modifications to the grout columns. Modifications: Subject to the results of the test program, the Construction Manager may require modifications in the jet grout production to achieve satisfactory results. Depending on the extent of modifications necessary, the Contractor may be required to repeat the construction of a test program.

3.03 INSTALLATION

- A. The Contractor shall use the same equipment, materials, and procedures as those determined in the test program to give satisfactory results to perform production jet grouting for construction of the cut-off walls. The jet grout elements shall be installed by constructing a single line of overlapping grout columns as shown in the Contract Drawings. The minimum grout column diameter shall be 36 inches, with a minimum overlap of at least 12 inches. Jet grouted columns shall be surveyed and checked by the Contractor before the start of coring. At the completion of each jet grouting operation, the area shall be thoroughly cleaned, and all waste slurry disposed of in accordance with approved work plan.
- B. A minimum mixing time of five (5) minutes and a maximum holding time of two (2) hours will be enforced for the grout batching. The grout hold time shall be calculated from the beginning of the initial mixing.
- C. Deviations: The installation of each column/panel shall be continuous. Deviations from plan locations at the ground surface shall not exceed 2 inches. Deviation from vertical at the ground surface shall not exceed 1 percent. Each column shall be designated uniquely.

3.04 AS-BUILT FIELD MEASUREMENT DATA

- A. Within 30 days after completing all field activities, a final report detailing mix proportions, testing data, daily logs, and all quality control records shall be submitted.

- B. The results of at least four (4) laboratory test shall be submitted demonstrating that the cement-bentonite installed provides a minimum unconfined compressive strength of 500 psi.
- C. Jet Grouting Performance Records: Submit daily records during the execution of the test program and jet grouting operations, including the following information:
 - 1. Grout hole geometry (column diameter, depth and location).
 - 2. Time and date of beginning and completion of each grout column.
 - 3. Grout mix data, including mix proportions, batch quantities and spoil disposal quantities. Batch quantities shall be cross checked daily with theoretical cement dosages from pump data.
 - 4. Erosion jet pressures used to construct each grout element.
 - 5. Grout rates and takes for each grout column. The amount of fluid returns shall be recorded on daily reports for each 5-foot grout column interval.
 - 6. Rates of rotation and withdrawal of jet grout monitor for each grout element.
 - 7. Other pertinent observations, such as: grout escapes, ground heave, or other unusual behavior. If loss of fluids, hydrofracture or inadvertent returns are observed in the borehole, via controls or anywhere on site, the Construction Manager shall be notified immediately, and corrective measures implemented under close observation.

3.05 ACCEPTANCE CRITERIA

- A. Jet grout columns will individually be considered acceptable when the columns satisfy the criteria below. Columns not satisfying these criteria shall be replaced at no additional cost to the DEP, by the Contractor, using approved methods and/or modifications. If a test fails, the Contractor may test the same column in another quadrant at the Contractor's expense.
 - 1. Unconfined compressive strength of cores: 200 psi at 28 days. A maximum of 10 percent of the tested specimens can fall below 200 psi per tested column but shall not be less than 100 psi. If tests on adjacent cores fail at the same elevation, both cores are considered non-compliant.
 - 2. The columns have been installed to the predetermined design elevation shown on the Contract Drawings or to the satisfaction of the Construction Manager. The minimum tip elevation of the column shall be the design elevation.
 - 3. The recorded length of the column has been verified as correct by the Construction Manager.

4. Horizontal alignment of the columns shall be within 2 inches of the planned location. The vertical inclination of columns shall be no greater than 1.0 percent. Horizontal overlap shall be at least 12 inches of a single column measured at the ground surface.
 5. The injection of binder does not fall below 10 percent of the target rate in accordance with the Work Plan.
 6. The recovery percentage of cores taken for strength verification purposes was greater than 80 percent.
 7. No 5-foot segment of column may contain more than 20 percent of its volume comprised of unimproved soil, and any individual or aggregation of lumps of unimproved soil must be no larger than 12 inches in greatest dimension. For making this determination, a single core is deemed representative of the entire cross section of a column. Any material not recovered during coring will be considered unimproved soil.
 8. Perform permeability testing of core samples at 28 days in accordance with ASTM D4138. The permeability for a fixed sample shall be less than 1×10^{-8} ft/sec.
 9. Set Time and Bleed: Grouts shall have a set time determined during mix design and the test section, and be indicated on the shop drawing. Samples shall be obtained at least once every shift for set time checks and bleed (1 and 2 hour). All samples shall be properly labeled and stored until the completion of the Project.
- B. Remedial Measures: Columns not satisfying the Acceptance Criteria shall be replaced at no additional cost by the Contractor, using methods approved by the Construction Manager. If a test fails, the Contractor may test the same column in another quadrant at the Contractor's expense. If a column does not meet strength, uniformity and permeability requirements, a replacement column shall be installed at Contractor's expense to encapsulate the column that did not pass the acceptance requirements. Alternatively, the Contractor may elect to core and test the two (2) adjacent columns at the depth in the panel where the test failed. If both tests pass, the column will be deemed acceptable. Remedial measures shall be included in the Quality Control Plan.

3.06 COLLECTION AND DISPOSAL OF WASTE SLURRY

- A. No material shall be stockpiled within 50 feet of existing structures without approval of the Construction Manager.
- B. Disposal of Debris and Containment for Grout Spoils:
 1. At all times during and at completion of waste slurry resulting from jet grouting operations, the site shall be maintained clear of all debris.

2. Use extreme care to prevent discharge of grout into any catch basins or municipal drainage systems. All grout, water, and other drilling/grouting waste material shall be contained within the work areas with berms or other measures. Storm water control best management practices shall be employed at all times in accordance with project permits. Clean up any grout discharges, spoils, or other unacceptable environmental impacts immediately. Provide continuous vacuum truck removal around jet areas to contain any potential discharges, as needed.

3.07 PREVENTION OF GROUND HEAVE

- A. In order to prevent ground heave and the potential for discharging grout into municipal drainage systems or potential for damaging the existing structures during jet grouting, appropriate drilling procedures shall be used consistent with best industry practices. The Contractor shall submit a procedure for maintaining a clear borehole and preventing ground heave and inadvertent discharges for information only. The procedure shall be used in the test program and during jet grouting operations.
- B. To mitigate the effects of potential loss of fluids or hydrofracture, appropriate procedures shall be used to maintain a clear borehole for return of spoils at all times during jet grouting operations. Grouting operations shall be interrupted in case the return of the spoil is blocked. Grouting shall resume when proper return of flow is restored.
- C. The amount of fluid returns shall be recorded on daily reports for each five (5) foot grout column interval. If loss of fluids, hydrofracture or inadvertent returns are observed in the borehole, controls or anywhere on site, the Construction Manager shall be notified immediately, and conditions monitored to implement necessary corrective measures. Protection of existing structures shall be the highest.

3.08 CONTRACT CLOSEOUT

- A. Provide in accordance with Section 017700.

END OF SECTION 313236

SECTION 313519 – GEOGRID SLOPE PROTECTION

PART 1 - GENERAL

1.01 SUMMARY

- A. This work shall consist of design, furnishing materials, and construction of geogrid reinforced slopes as indicated and at locations shown on the Contract Drawings.

1.02 PAYMENT

- A. No separate payment shall be made for performing any Work required under this Section. All costs for Work required by this Section shall be included in the applicable Cove Park lump sum(s), unit price(s), or allowance(s) as set forth in Section 012901.

1.03 REFERENCES

- A. ASTM International (ASTM):
 1. D1557: Standard Test Methods for Laboratory Compaction Characteristics of Soil Using Modified Effort (56,000 ft-lb/ft³ (2,700 kN-m/m³)).
 2. D1117: Standard Guide for Evaluating Nonwoven Fabrics.
 3. D1238: Standard Test Method for Melt Flow Rates of Thermoplastics by Extrusion Plastometer.
 4. D1388: Standard Test Method for Stiffness of Fabrics.
 5. D1505: Standard Test Method for Density of Plastics by the Density-Gradient Technique.
 6. D2455: Standard Test Method for Identification of Carboxylic Acids in Alkyd Resins.
 7. D374: Standard Test Methods for Thickness of Solid Electrical Insulation.
 8. D4355: Standard Test Method for Deterioration of Geotextiles by Exposure to Light, Moisture and Heat in a Xenon Arc-Type Apparatus.
 9. D4595: Standard Test Method for Tensile Properties of Geotextiles by the Wide-Width Strip Method.
 10. D4603: Standard Test Method for Determining Inherent Viscosity of Poly (Ethylene Terephthalate) (PET) by Glass Capillary Viscometer.

11. D5199: Standard Test Method for Measuring the Nominal Thickness of Geosynthetics.
12. D5261: Standard Test Method for Measuring Mass per Unit Area of Geotextiles.
13. D6637: Standard Test Method for Determining Tensile Properties of Geogrids by the Single or Multi-Rib Tensile Method.

B. Geosynthetic Research Institute (GRI)

1. GG2: Test Method for Geogrid Junction Strength.

C. U.S. Department of Transportation Federal Highway Administration (FHWA):

1. FHWA-NHI-10-024, GEC 011 “Design of Mechanically Stabilized Earth Walls and Reinforced Soil Slopes – Volume I”
2. FHWA-NHI-10-025, GEC 011 “Design of Mechanically Stabilized Earth Walls and Reinforced Soil Slopes – Volume II”

1.04 RELATED SECTIONS

- A. General Conditions Article 4.7 – Shop Drawings and Other Submittals.
- B. Section 011414 - Control of Work.
- C. Section 012901 - Measurement and Payment.
- D. Section 014300 - Quality Requirements.
- E. Section 015713 – Erosion Control, Sedimentation, and Containment of Construction Materials.
- F. Section 017700 - Contract Closeout.
- G. Section 021600 - Excess Clean Fill, Contaminated Soil, and Groundwater Management and Disposal.
- H. Section 023214 – Vibration and Noise Monitoring.
- I. Section 310930 – Geotechnical Instrumentation.
- J. Section 312300 – Excavation and Fill.

1.05 DEFINITIONS

- A. Utility: The company, agency, or other entity that provides service.

- B. Coir Mat: 100 percent organic, high strength woven coconut grids, effective on environmentally sensitive locations where high strength and durability are required. Used as an erosion control blanket for the steep slope locations.

1.06 SUBMITTALS

- A. Submit the following in accordance with General Conditions Article 4.7:
 - 1. Materials Sources including name of source, location, date of sample, sieve analysis, and laboratory compaction characteristics.
- B. Qualifications of Contractor's Geogrid installer, as specified in paragraph 1.07.C.
- C. Qualifications of independent Testing laboratory responsible for testing the geogrid, as specified in Paragraph 1.07.D.
- D. The Contractor shall submit the manufacturer's certification for approval at least thirty days prior to the start of reinforced slope construction. The manufacturer's certification shall indicate that the geogrid reinforcement has been evaluated in full compliance with this section and that the materials meet the full requirements as shown on the Contract Drawings and as specified herein. The Contractor's submittal package shall include but not be limited to, test results for tension/creep, durability/aging, construction damage, pullout and quality control. The manufacturer shall also provide written certification that all resin used to produce the geogrid is virgin and classified as high-density polyethylene or high molecular weight polyester and is capable of withstanding direct exposure to sunlight for 120 days with no measurable deterioration as measured per ASTM D4355.
- E. The manufacturer of the geogrid reinforcement shall supply written certification that the resins and additives used in the manufacture of the geogrid (including coating material, if applicable) are specifically formulated to provide long-term design strength and long-term interlock with soil; and that the manufactured geogrid reinforcement products are durable in a soil environment for applications up to 100 years and are fit for use in long-term, critical reinforcement applications. Certification shall be notarized and signed by an officer of the manufacturing company.
- F. The geosynthetic reinforcement shall be manufactured with a high degree of quality control (QC). The purpose of the QC testing program is to verify that the geogrid being supplied is representative of the geogrid used for the performance testing as described herein. Sampling can be performed on sacrificial portions of the supplied material, in the required testing cannot be produced by the manufacturer.
- G. Conformance testing shall be performed as part of the manufacturing process. If the manufacturer has an established quality control program, then documentation describing the program shall be submitted to the Architect/Engineer for review. As a minimum, the manufacturer shall conduct quality control testing as outlined below:

Table 313519.13-1		
Test	Test Procedure	Testing Frequency (SY)
Specific Gravity (HDPE)	ASTM D1505	600
Melt Flow Index (HDPE)	ASTM D1238	600
Tensile Strength	ASTM D6637	600
Coating Thickness (PET)	ASTM D374	600
Intrinsic Viscosity (PET)	ASTM D4603	600
Carboxyl End Group (PET)	ASTM D2455	600

- H. Samples not satisfying the material requirement provided in the material product sheet shall result in the rejection of the applicable rolls at no cost to the NJDEP. At the Contractor’s or manufacturer’s discretion and expense, additional testing of individual rolls may be performed to more closely identify the non-complying rolls and/or to qualify individual rolls.
- I. The manufacturer shall certify the quality of the rolls of geogrid reinforcement. As a minimum, the manufacturer shall provide quality control certificates for each batch of resin and each shift production. These quality control certificates shall be signed by an officer of the manufacturer (such as production manager) and supplied to the Construction Manager at least two (2) weeks prior to installation of the geogrid. The quality control certificate shall include:
 - 1. Roll numbers and identification.
 - 2. Sampling procedures.
 - 3. Results of quality control tests, including a description of test methods used.
- J. The material submittal shall satisfactorily address the criteria outlined in “Design of Mechanically Stabilized Earth Walls and Reinforced Soil Slopes – Volume I”, FHWA-NHI-10-024, Chapter 9.
- K. The Contractor shall submit detailed construction drawings and shop drawings for approval by the Architect/Engineer within 30 days of authorization to proceed and at least 60 days prior to the beginning of reinforced slope construction. As a minimum, the shop drawings shall reflect the minimum geogrid reinforcement length, long-term design strength and spacing shown in the Contract Drawings. The drawings shall be prepared

and sealed by a Professional Engineer licensed in the State of New Jersey. The fully detailed Plans shall include but not be limited to the following items:

1. Plan, elevation and cross-section sheets.
 - a. An elevation view indicating elevations at top and bottom of reinforced slope, limits and dimensions of erosion control blanket, beginning and end stations, whole station points and each level of geogrid reinforcement. The location of proposed final ground line points shall be indicated.
 - b. The length and type of reinforcement shall be shown.
 - c. The plan view shall reflect the horizontal alignment and shall indicate the offset from the horizontal line to the front face of the slope. All utilities, signs, lighting, guide rails, etc. that affect the reinforced slope shall be shown.
 - d. Cross-sections shall show limits of construction, embankment and excavation limits, and limits and extent of the reinforced soil fill volume.
2. Typical details for geogrid reinforcement.
3. Temporary slope face support, if required.
4. All details for construction of the reinforced slope around drainage areas, lighting fixtures, guided rail, for erosion control shall be clearly shown.

1.07 QUALITY ASSURANCE

- A. Comply with the requirements specified in Section 014300.
- B. The Contractor shall conduct a quality assurance program verifying that the product supplied to the jobsite meets the design requirements. The Contractor's Independent Testing Laboratory shall conduct field testing of samples conducted at the frequencies outlined below:

Table 313519.13-2		
Tensile Strength	Test Procedure	Testing Frequency (SY)
2% Strain (lb/ft)	ASTM D6637	1200
5% Strain (lb/ft)	ASTM D6637	1200
Ultimate Strength (lb/ft)	ASTM D6637	1200
Junction Strength (lb/ft)	GRI-GG2	1200

The laboratory conducting the testing shall be certified by the Geosynthetic Accreditation Institute.

C. Geogrid Installer Qualifications

1. Not less than three (3) years’ experience in the installation of geogrid reinforcement in similar conditions and of equal complexity or have training by the manufacturer on-site.

D. Independent Testing Laboratory:

1. The Contractor shall engage an independent testing laboratory to be responsible for field testing, inspection, and certified reports for the geogrid installation. Testing laboratory shall have not less than three (3) years’ experience performing testing on geogrid reinforcement for similar applications.

E. Perform work in accordance with issued permits, Municipalities (City of Hoboken, City of Jersey City, and Township of Weehawken) and the state of New Jersey, ordinances, and regulations.

F. Testing shall be performed as specified herein. The Contractor shall engage an independent testing laboratory to be responsible for field testing, inspection, and certified reports. Reports shall be submitted to the Construction Manager daily.

1.08 DELIVERY, STORAGE AND HANDLING

- A. Comply with the requirements in Section 016100.
- B. Provide a storage area for geogrid reinforcement of adequate size as to not damage the rolls.

1.09 SITE CONDITIONS

- A. Geotechnical Investigation Results Report: The report is for information only and is not part of the Contract Documents. The boring logs are included as an appendix in the report and indicate conditions encountered only at borehole locations. This report shall not be construed as to guarantee that other subsurface materials will not be present or that

proportions of materials will not vary from that shown on the boring logs or in the soil profiles. The borehole locations and soil profiles are part of the Contract Drawings.

PART 2 - PRODUCTS

2.01 MATERIALS

A. Fill Material

1. Soil within and behind the geogrid reinforced shall meet the requirements of embankment fill, except that material larger than ¾ inches shall be removed and the soil shall contain no more than 20 percent by weight of material passing the No. 200 sieve. The exception is a 2 ft wide zone behind the slope face where the percent passing the No. 200 sieve shall be not less than 20 percent and not greater than 35 percent. The maximum particle size limit of ¾ inches shall also apply to this zone.

B. Geogrid

1. The geogrid material shall be a regular network of integrally connected polymer tensile elements with aperture geometry sufficient to permit significant mechanical interlock with the surrounding soil. The geogrid structure shall be dimensionally stable and able to retain its geometry under manufacture, transport and installation. Two types of geogrids shall be placed as shown in the Contract Drawings, which shall be referred to as Primary and Secondary Geogrids. The geogrid shall have the minimum long-term design strength (T_a) shown in the following table.

Table 313519.13-3		
Property	Type 1	Type 2
Long-Term Design Strength (lb/ft) (in direction perpendicular to slope face)	1450	770

2. The long-term strength shall be determined as outlined in “Design of Mechanically Stabilized Earth Walls and Reinforced Soil Slopes – Volume II”, FHWA-NHI-10-025. The long-term design strength shall be based on the minimum average roll value (MARV) of the geogrid ultimate strength and shall reflect the effect of creep, installation damage and chemical and biological degradation. The reduction factor for installation damage shall correspond to the soil fill material specified herein.

C. Coir Mat

1. The coir mat 400 series, or equivalent shall have the following property values:

Table 313519.13-4		
Property	Test Procedure	Typical Value
Material	n/a	Woven Material of coir from high strength coconut fiber
Thickness	ASTM D5199	0.30 in.
Mass per unit area min	ASTM D5261	11.8 oz/sq. yd.
Wide width tensile – Dry MD X CD	ASTM D4595	42 lbs./in. 40 lbs./in.
Wide width tensile – Wet MD X CD	ASTM D4595	38 lbs./in. 30 lbs./in.
Maximum Elongation – Dry MD X CD	ASTM D4595	33% 31%
Maximum Elongation – Wet MD X CD	ASTM D4595	36% 31%
Flexural Rigidity	ASTM D1388	4070 x 3923 mg -cm
Water Absorption	ASTM D1117	163%
Water Velocity	Flume Test	8 ft./sec.
Shear Test	Flume Test	3.2 psf
“C” Factor	Flume Test	0.002
Open Area	Measured	65%

PART 3 - EXECUTION

3.01 INSTALLATION PROCEDURES

- A. Areas immediately beneath the installation area of the geogrid slope shall be prepared as shown in the Contract Drawings, as specified, or as directed by the Construction Manager. The subgrade surface shall be level, free of deleterious materials and loose or otherwise unsuitable soils prior to placement of the geogrid reinforcement as directed by the Construction Manager. The subgrade shall be proof-rolled to provide a uniform and firm surface. Any soft areas, as determined by the Construction Manager, shall be excavated and replaced with suitable compacted soil. Benching the back cut into competent soil shall be required to improve stability.
- B. Excavation of unsuitable material and replacement with select fill, as directed by the Construction Manager, will be paid in accordance with Section 012901.

C. Construction Requirements:

1. The Contractor shall check the geogrid material upon delivery to ensure that the proper material has been received. During all periods of shipment and storage, the material shall be protected from temperatures greater than 60 degrees C, mud, dirt, dust and debris, or materials which may permanently affix to the gridwork. The manufacturer's instructions regarding protection from direct sunlight shall be followed. At the time of installation, the geogrid reinforcement will be rejected by the Construction Manager if it has defects, tears, punctures, flaws, deterioration, or damage incurred during manufacture, transportation, storage or installation. Rejected geogrids shall be replaced by the Contractor at no cost to the DEP.
2. Geogrid material supplier shall provide a qualified and experienced representative on site at the initiation of construction of the geogrid reinforced slope for a minimum of three days to assist the Contractor.

D. Geogrid Placement:

1. The geogrid shall be placed in accordance with the manufacturer's recommendations. The reinforcement shall be placed at the proper elevation, location, and orientation between the layers of compacted soil as shown on the shop drawings or as directed by the Construction Manager.
2. The geogrid shall be continuous without joints or overlapping in the direction perpendicular to the slope face. Adjacent strips shall be overlapped a minimum of 6 inches in order to prevent loss of soil.
3. To prevent damage, only that amount of reinforcement required for immediately pending work shall be placed. After a layer of reinforcement has been placed, it shall be pulled tight and held in place by means of pins or small piles of soil until the subsequent layer of soil is placed and compacted. Tracked vehicles shall not be allowed on the geogrid reinforcement until at least 6 inches of soil has been placed. During construction, each layer of embankment shall be kept approximately level.
4. The geogrid reinforcement shall be placed directly on the compacted horizontal surface of the preceding layer. The reinforcement shall be placed within 3 inches of the intended elevation shown on the approved shop drawings and extend the length shown in the elevation view unless otherwise directed by the Construction Manager. Correct placement of the reinforcement shall be verified by the Contractor.
5. Where it is necessary to cut reinforced geogrid for subsequent placement of utilities, drainage pipe, inlets, etc., the geogrid shall be connected/spliced to provide continuity of tensile resistance through the use of either a mechanical polymer bar or sewing with Kevlar sewing thread perpendicular to the direction of loading at the ends of the materials.

E. Fill Placement:

1. Fill shall be compacted in accordance with Section 312300. Fill shall be placed, spread and compacted in such a manner as to minimize development of wrinkles and/or displacement of geosynthetic reinforcement. Soil fill shall be placed in maximum loose lift thickness of 8 inches where heavy compaction equipment is to be used, and in maximum loose lift thickness of 6 inches where hand operated equipment is to be used.
2. Backfill shall be graded away from the slope crest and rolled at the end of each workday to prevent ponding of water on the reinforced soil layer.
3. Tracked vehicles shall not operate on the area until at least 6 inches of soil cover the reinforcement material. Turning of tracked vehicles shall be minimized to prevent displacement of the reinforcement material or the completed embankment. Rubber tire equipment may, if approved by the Construction Manager, operate on the geogrid reinforcement at slow speeds less than 10 mph and with a minimum of turning and braking.
4. Ruts that may be created in the granular fill due to construction traffic shall be filled with additional granular material, rather than blading adjacent material into the rut.

F. Coir Mat Placement:

1. The coir mat shall be placed according to manufacturer's recommendations at locations shown on the Contract Drawings.

3.02 FIELD QUALITY CONTROL

- A. The Contractor shall conduct inspection and testing by an Independent Testing Laboratory to achieve the specified quality.
- B. The testing agency shall maintain a qualified representative on site during installation of geogrid reinforcing material.
- C. Perform field density testing in accordance with ASTM D1556, ASTM D2167, or ASTM D6938.
- D. Evaluate field density test results in relation to maximum dry density as determined by testing material in accordance with ASTM D1557 (Modified Proctor).
- E. Location of field density tests shall be mutually acceptable to testing laboratory and Construction Manager.
- F. In the event compacted material does not meet specified in-place density, re-compact material and re-test area until specified results are obtained.

3.03 PROTECTION

- A. Protect any exposed areas of the geogrid reinforcement material from being torn or degraded during installation prior to embankment fill material being placed.

3.04 CONTRACT CLOSEOUT

- A. Provide in accordance with Section 017700.

END OF SECTION 313519

NO TEXT ON THIS PAGE

SECTION 314116 - STEEL SHEET PILING

PART 1 - GENERAL

1.01 DESCRIPTION

- A. This Section specifies requirements for steel sheet piling used as part of permanent construction, for cut-off walls to control seepage under the T-walls and I-wall systems.

1.02 PAYMENT

- A. No separate payment shall be made for performing any Work required under this Section unless noted otherwise. All costs for Work required by this Section shall be included in the applicable lump sum, unit price(s), or allowance(s) as set forth in Section 012901.

1.03 REFERENCES

- A. Unless otherwise noted, the latest edition of the following codes, standards, and publications shall govern the work under this Section. If any conflicts exist between these codes, standards, and publications the more restrictive requirements shall govern.
 - 1. American Society for Testing and Materials International (ASTM)
 - a. ASTM A 36 Structural Steel.
 - b. ASTM A 328 Structural Steel.
 - c. ASTM A 307 Structural Steel.
 - d. ASTM A 153 Steel Galvanization.
 - 2. American Welding Society (AWS)
 - a. AWS D1.1 Structural Welding Code – Steel.
 - b. AWS D1.5 Bridge Welding Code.
 - 3. Steel Structures Painting Council (SSPC)
 - a. SSPC SP 5 White Metal Blast Cleaning.
 - b. SSPC PA 2 Measurement of Dry Paint Thickness with magnetic gages.

1.04 RELATED SECTIONS

- A. General Conditions Article 4.7 – Shop Drawings and Other Submittals
- B. Section 011414 – Control of Work
- C. Section 012901 – Measurement and Payment
- D. Section 014300 – Quality Requirements
- E. Section 016100 – Control of Materials
- F. Section 017423 – Cleaning up
- G. Section 017700 – Contract Closeout
- H. Section 023214 - Vibration Monitoring & Noise Monitoring
- I. Section 099702 – Coal Tar Epoxy
- J. Section 310930 – Geotechnical Instrumentation
- K. Section 313236 – Jet Grouting

1.05 DESIGN AND PERFORMANCE

- A. Site Conditions
 - 1. Sequence of construction, including any required excavation, filling or backfilling, shall conform to the requirements shown on the Contract Drawings.
 - 2. When concrete is less than seven (7) days old, do not drive sheet piles closer to the concrete than the distance computed by the formula below:

$$D = \frac{1}{7}\sqrt{E}$$

Where:

E = Energy of pile hammer in foot pounds

D = Distance in feet

- 3. Sheet piling shall not be installed until the method of installation and sequence of driving has been approved by the Architect/Engineer.
- 4. Protect existing structures, roadways, including overhead and buried utility lines, to the satisfaction of the Construction Manager.

B. Alignment and Tolerances

1. Unless otherwise shown on the Contract Drawings, after installation, the slope of the steel sheet piles shall not deviate from the vertical by more than one (1) percent.
2. Sheet Piles at cut-off elevations shall not deviate laterally from required location by more than the tolerance shown on the Contract Drawings.

1.06 SUBMITTALS

A. Contractor shall submit the following qualifications in accordance with General Conditions 4.7

1. Submit the following qualifications ten (10) weeks prior to the installation of sheet Piles:
 - a. Qualifications of Contractor's pile installer, as specified in Paragraph 1.06.C.
 - b. Qualifications of Independent Geotechnical Engineering Consultant, as specified in Paragraph 1.06.D.

B. Certified mill test reports for steel sheet piles.

C. A complete description of the hammers and driving equipment including caps and guides.

D. Verification of welder qualifications.

E. The proposed procedure for installing the sheet piling including the sequence for driving all sheet piles.

1.07 QUALITY ASSURANCE

A. Comply with the requirements specified in Section 014300.

B. Perform work in accordance with issued permits, Municipalities (City of Hoboken, City of Jersey City, and Township of Weehawken) and the State of New Jersey, ordinances, and regulations.

C. Steel Sheet Pile Installer Qualifications

1. Not less than three (3) years' experience in the installation of sheet-piles in similar conditions and of equal complexity as the proposed system.

2. Completed not less than five (5) successful steel sheet pile driving projects of similar scope and magnitude as the proposed system within the past ten (10) years.
 3. Pile driving operators and on-site supervisors with not less than three (3) years of experience installing sheet -piles.
 4. Welders are to be AWS certified and licensed in the State of New Jersey. Proof of licensure will be required at the site.
- D. Independent Geotechnical Consultant Qualifications:
- E. Contractor shall engage an independent geotechnical consultant responsible for field inspection, to confirm conformance with Contract requirements, and submit certified reports.
- F. The Consultant shall be a State of New Jersey licensed Professional Engineer specializing in geotechnical engineering responsible for designing and monitoring installation of steel sheet piles.
- G. Not less than five (5) years of experience related to pile installation, pile instrumentation, and pile testing.
- H. Consultant's field representative shall have at least three (3) years supervisory experience in sheet pile installation construction.
- I. Independent Testing Laboratory:
1. The Contractor shall engage an independent testing laboratory to be responsible for field testing, inspection, and certified reports.
 2. Not less than three (3) years' experience performing oversight of sheet pile installations for similar applications.
- J. The peak particle velocity during sheet pile driving operations, shall meet the requirements in accordance with Section 023214.
- K. The noise above ambient levels produced from sheet pile driving operations, shall conform to noise regulations in accordance with Section 023214.
- L. All welding shall be performed in accordance with AWS D1.1.

PART 2 - PRODUCTS

2.01 MATERIALS

- A. Steel Sheet Piling
 - 1. ASTM A328, unless otherwise shown on the Contract Drawings. Required sections shall be as shown on the Contract Drawings.
- B. Steel wale and plates, ASTM 36, unless otherwise shown on the Contract Drawings.
- C. Bolts, Nuts and Washers:
 - 1. ASTM A307, galvanized to 2 oz. per square foot, in accordance with ASTM A 153, unless otherwise shown on the Contract Drawings.
- D. Coating for Steel Sheet Piles
 - 1. Coal tar epoxy as per Section 099702.

PART 3 - EXECUTION

3.01 INSTALLATION

- A. Pile Driving Equipment
 - 1. Use an approved driving head designed to properly fit a pair of piles to prevent damage to the top of the piles during driving.
 - 2. Use an approved impact or vibratory pile hammer of sufficient size to drive the sheet piles to the tip elevation(s) shown on the Contract Drawings without causing stresses due to driving in excess of 90 percent of the yield strength (F_y) of the pile material.
- B. Welding and Splicing
 - 1. Perform all welding in accordance with requirements for shielded metal arc welding of AWS D 1.5 for bridges or AWS D1.1 for buildings and other structures.
 - 2. Only use welders qualified by tests prescribed in AWS D1.1 or AWS D 1.5, as applicable.
 - 3. Reinforce pile tips, if and as shown on the Contract Drawings.
 - 4. Splicing of sheet piles shall not be permitted.

C. Pile Driving

1. Use an approved guide frame or templet to set sheet piles in proper position and alignment and to provide adequate lateral support to maintain vertical alignment during driving. Where field conditions require, use two (2) levels of guide wales to maintain vertical alignment during driving.
2. The steel sheet piles shall be properly set and "shaken out" prior to driving. After placing a pair of sheets within their interlocks, they shall be lowered as far as possible. Should the sheets bind or hang up in their interlocks before bearing on the ground, adjacent sheets shall be picked up in pairs and shaken out as required, until the sheets ride smoothly within their interlocks and simultaneously bear on the ground.
3. Top of sheet pile shall be normal to the driving force.
4. Drive sheet piles to the tip elevations shown on the Contract Drawings. Each pair of sheet piles shall not be driven more than 5 feet ahead of the adjacent sections.
5. Sheet piles shall be driven in such a manner as to prevent piles from leaning in the direction of driving and to provide a continuous closure of sheet piles, where closure is required. Where possible, drive sheet piling with the ball end leading. If an open socket is leading, provide a bolt or similar object in the bottom of the interlock to keep interlock free of soil material.
6. At the completion of the driving operation on a pile, the pile shall be undamaged, free of defects and in compliance with the requirements of this Section.
7. Cut sheet piles off at cut-off elevation as shown on the Contract Drawings as soon as practical after driving. Prior to cutting sheet piles, the top of each pair of sheet piles shall be surveyed.
8. No jetting will be permitted without specific approval of the Construction Manager.
9. Provide vibration and noise monitoring in accordance with Section 023214.

D. Corrections of Deficiencies

1. The Contractor shall notify the Construction Manager immediately, in writing, of the failure of any sheet pile to meet any requirement of this Section. Such written notification shall include all information required for the evaluation of remedial measures.

2. Except for sheet piles, which do not comply with the requirements of this Section, due to encountering during driving an underground obstruction consisting of a rock or manufactured or construction material as shown by the Contractor, and as determined by the Construction Manager on the basis of all field information, the Contractor shall perform all remedial work at no additional cost to the DEP and in accordance with both the applicable Unit Price provisions, if any, and the modified design and details, if any, as approved by the Construction Manager.
- E. Obstructions
1. In the event that physical obstructions are encountered that cannot be relocated or temporarily removed to permit the continuous installation of the steel sheet pile curtain wall, the Contractor shall present detailed information on the necessary space required in the sheet pile curtain wall to the Construction Manager for direction. It is expected that the space between the steel sheet pile curtain wall shall be sealed by jet grouting to develop a seal in the curtain wall.

3.02 CONTRACT CLOSEOUT

- A. Provide in accordance with Section 017700

END OF SECTION 314116

NO TEXT ON THIS PAGE

SECTION 315000 - EXCAVATION SUPPORT SYSTEMS

PART 1 - GENERAL

1.01 DESCRIPTION

- A. Provide excavation support systems as necessary to perform all work and in compliance with the Contract Drawings.
- B. Design, furnish, and install excavation support systems to maintain lateral support, prevent loss of ground, limit soil movements to acceptable limits and protect from damage existing and proposed improvements including pipelines, utilities, structures, roadways, railroads and all other types of facilities.
- C. The requirement of specified excavation support systems shall be in accordance with OSHA regulations.
- D. Common types of excavation support system include but are not limited to singular or multiple stages comprised of cantilevered or internally braced soldier piles and lagging, steel sheet pile wall, trench box, or combinations thereof. Trench box temporary excavation support system is only acceptable for pipe or utility trench excavations as approved by the Construction Manager. Temporary unsupported open cut excavation with stable sloping sides is allowed where applicable.
- E. All steel sheet pile walls, or soldier piles shall be removed unless otherwise directed by the Construction Manager.
- F. Wherever the word "sheeting" is used in this section or on the Contract Drawings, it shall be in reference to any type of excavation support system specified except trench boxes.
- G. Construction of the excavation support systems shall not disturb the existing structures or the completed proposed resist structures. Damage to any structures shall be repaired at the Contractor's expense.
- H. Adjacent structures are those that are bear upon soils above the proposed excavation depth and within a distance equal to twice the total depth of the excavation away from the closest edge of the excavation. Monitoring and protection of adjacent structures as specified and indicated.
- I. Vibration and Noise monitoring for excavation support systems shall be performed in accordance with Section 023214.
- J. Settlement monitoring for excavation support systems shall be performed as specified in Section 310930.

- K. The Contractor shall be responsible for the additional costs for correcting any failure, damages, subsidence, upheaval or cave-ins as a result of improper installation, maintenance or design of the excavation support systems. Pay for all claims, costs, and damages that arise as a result of the work performed at Contractor's expense.

1.02 PAYMENT

- A. No separate payment shall be made for performing any Work required under this Section. All costs for Work required by this Section shall be included in the applicable lump sum(s), or unit price(s) as set forth in Section 012901.

1.03 REFERENCES

- A. American Concrete Institute (ACI):
 - 1. 304: Recommended Practice for Measuring, Mixing, Transporting and Placing Concrete.
- B. American Society for Testing and Materials International (ASTM):
 - 1. A36: Standard Specification for Structural Steel.
 - 2. A572: Standard Specification for High-Strength Low Alloy Columbium-Vanadium Structural Steel.
 - 3. A615: Standard Specifications for Deformed and Plain Billet Steel Bars for Concrete Reinforcement.
- C. American Wood-Preserves Association (AWPA) Standards.
 - 1. P23-10: Standard for Chromated Copper Arsenate Type C (CCA-C).
 - 2. P50-10: Standard for Fire Retardant FR-2 (FR-2).
- D. American Welding Society (AWS)
 - 1. D1.1: Structural Welding Code.
- E. Occupational Safety and Health Administration (OSHA) Standards and Regulations contained in Title 29: Subpart P - Excavations, Trenching and Shoring.

1.04 RELATED SECTIONS

- A. General Conditions Article 4.7 – Shop Drawings and Other Submittals.
- B. Section 011414 – Control of Work

- C. Section 012901 – Measurement and Payment
- D. Section 014300 - Quality Requirements.
- E. Section 016100 - Control of Materials.
- F. Section 017423 – Cleaning up
- G. Section 017700 - Contract Closeout.
- H. Section 023214 - Vibration and Noise Monitoring
- I. Section 023219 - Subsurface Utility Locating (Potholing).
- J. Section 033000 - Cast-in-Place Concrete.
- K. Section 310930 – Geotechnical Instrumentation
- L. Section 312319 - Dewatering

1.05 SUBMITTALS

- A. Submit the following in accordance with General Conditions Article 4.7
 - 1. Submit the following qualifications a minimum of four (4) weeks prior to the construction:
 - a. Qualifications of Contractor’s excavation support system designer as specified in Paragraph 1.06.G.
 - b. Qualifications of Contractor’s excavation support system installer as specified in Paragraph 1.06.H.
 - c. Qualifications of Contractor’s excavation support system installation supervisor as specified in Paragraph 1.06.I.
 - d. Qualifications of vacuum excavation subcontractor as specified in Paragraph 1.06.F, if deformation monitoring points for utilities are utilized.
 - 2. Submit an excavation support plan stamped and signed by a Registered Professional Engineer in the State of New Jersey at least two (2) weeks prior to start of the construction. Do not submit design calculations. The review will be only for the information of the Construction Manager and third parties for an overall understanding of the project relating to access, maintenance of existing facilities, and proper utilization of the site. The Contractor remains responsible for the adequacy and safety of the means, methods, and sequencing of construction. The plan shall include the following, but not limited to:

- a. Proposed excavation support system(s), details, location, layout, depths, extent of different types of support relative to existing features and the permanent structures to be constructed, and methods and sequence of installation and removal.
 - b. Certificate of Design.
 - c. A list of all design assumptions, including safety factors used for the excavation support system(s) and all lateral pressures used for each system.
 - d. Requirements of dewatering during the construction, in accordance with Section 312319.
 - e. Minimum lateral distance from the edge of the excavation support system for use for vehicles, construction equipment, and stockpiled construction and excavated materials.
 - f. List of equipment used for installing the excavation support systems.
 - g. Monitoring schedule, installation procedures and location plans for vibration and noise monitoring and geotechnical instrumentation to monitor ground surface, excavation support system, adjacent structures, and groundwater fluctuation during the entire construction period, in accordance with Section 023214 and Section 310930.
3. A Construction Contingency Plan specifying the methods and procedures to maintain excavation support system stability if the allowable movement of the adjacent ground surface and adjacent structures is exceeded.
 4. A monitoring data Report within one (1) day of collection from the vibration and noise recording equipment, observation wells, deformation monitoring points and offset lines. Monitoring Report shall be in accordance with Section 310930.
 5. For excavation support systems left in place, submit the following as-built information prior to backfilling and covering the excavation support systems:
 - a. Survey locations of the excavation support systems, including coordinates of the ends and points of change in direction.
 - b. Type of the excavation support system.
 - c. Elevations of top and bottom of the excavation support systems left in place.

1.06 QUALITY ASSURANCE

- A. Provide in accordance with Section 014300.

- B. Conform to the requirements of the OSHA Standards and Interpretations: "Part 1926 Subpart P - Excavation, Trenching, and Shoring".
- C. Noise-inducing operations shall conform to noise regulations provided in accordance with Section 023214.
- D. Retain the services of an independent Geotechnical Instrumentation consulting firm meeting the requirements as specified in Section 023214 and Section 310930.
- E. The peak particle velocity for pile driving, or other vibration-inducing operations, shall meet the requirements as specified in Section 023214.
- F. If utilizing deformation monitoring points (DMPs) for utilities, vacuum excavation shall be performed by subcontractor having five (5) years of experience in non-destructive vacuum excavation methods for utilities.
- G. Prepare design, including calculations and drawings, under the direction of a Professional Engineer registered in the State of New Jersey and having the following qualifications:
 - 1. Not less than ten (10) years experience in the design of specific excavation support systems to be used.
 - 2. Completed not less than five (5) successful excavation support system projects of equal type, size, and complexity within the last five (5) years.
- H. Excavation Support System Installer's Qualifications:
 - 1. Not less than three (3) year experience in the installation of similar types and equal complexity as the specific excavation support systems to be used.
 - 2. Completed not less than three (3) successful excavation support systems of similar type and equal complexity as the specific excavation support systems to be used.
- I. Install all excavation support systems under the supervision of a supervisor having the following qualifications:
 - 1. Not less than five (5) years experience in installation of systems of similar type and equal complexity as the specific excavation support systems to be used.
 - 2. Completed at least five (5) successful excavation support systems of similar type and equal complexity as the specific excavation support systems to be used.
- J. All welding shall be performed in accordance with AWS D1.1.

1.07 DESIGN CRITERIA

- A. Design of excavation support systems shall meet the following minimum requirements:

1. Support systems shall be designed for earth pressures, hydrostatic pressure, equipment, temporary stockpiles, construction loads, roadways, railroads, and other surcharge loads.
2. Design a bracing system to provide sufficient reaction to maintain stability.
3. Limit movement of ground adjacent to the excavation support system to be within the allowable ground deformation in accordance with Section 310930.
4. Design the embedment depth below bottom of excavation to minimize lateral and vertical earth movements and provide bottom stability. Toe of braced temporary excavation support systems shall not be less than 5 feet below the bottom of the excavation.
5. Design excavation support systems to withstand an additional 2 feet of excavation below proposed bottom of excavation without redesign except for the addition of lagging and/or bracing.
6. Maximum width of pipe trench excavation shall be as indicated on the Contract Drawings.
7. Do not cast permanent structure walls directly against excavation support systems/walls.
8. The design location of the excavation support wall shall be determined such that the installed wall and bracing system components are all located outside the limits of the permanent structure. Construction tolerances (e.g. wall verticality) shall be considered in determining the plan location.

1.08 DELIVERY, STORAGE AND HANDLING

- A. Provide in accordance with Section 016100 and as specified.
- B. Store sheeting and bracing materials to prevent sagging which would produce permanent deformation. Keep concentrated loads which occur during stacking or lifting below the level which would produce permanent deformation of the material.

1.09 SITE CONDITIONS

- A. A Geotechnical Investigation Results Report was prepared for this Project and is provided as an attachment to the Contract Documents. Subsurface conditions are provided in the Soil Profile as part of the Contract Drawings.
- B. The boring logs are included as an appendix in the report and indicate subsurface conditions encountered at only the borehole location. This report shall not be construed as to guarantee that other subsurface materials will not be present or that proportions of

materials will not vary from that shown on the boring logs. The borehole locations and soil profiles are part of the Contract Drawings.

- C. Protect adjacent structures, underground utilities and other construction from damage caused by the installation of the excavation support systems.

PART 2 - PRODUCTS

2.01 MATERIALS

A. Structural Steel

- 1. All soldier piles, wales, rakers, struts, wedges, plates, water stops, and accessory steel shapes shall conform to ASTM A36 or ASTM A572

B. Steel Sheet Piling:

- 1. ASTM A328, continuous interlocking type and shall be hot-rolled sheet pile.

C. Timber Lagging Left in Place:

- 1. Pressured treated per AWPA standards.

D. Raker Ties:

- 1. ASTM A615 Grade 60.

E. Concrete: Refer to Section 033000.

F. Tamping tools adapted for backfilling voids after removal of the excavation support system.

G. Provide specific trench box sizes for each pipe and utility excavation with structural capacity of retaining soil types as described in OSHA's 29 CFR Part 1926 Subpart P.

2.02 EQUIPMENT

- A. A vibratory hammer shall be utilized for driving the sheet piling providing that such operations do not exceed vibration and/or noise requirements in accordance with Section 023214. Impact hammer shall be utilized when vibratory hammer is unable to drive sheet piling to required depth and/or unable to meet vibration requirements. Impact hammer shall meet noise requirement in accordance with Section 023214.

PART 3 - EXECUTION

3.01 INSTALLATION

- A. Installation of the excavation support systems shall not commence until the related earth excavation and fill and dewatering submittals have been reviewed by the Construction Manager with all Construction Manager's comments satisfactorily addressed.
- B. Install excavation support systems in accordance with the excavation support system plan.
- C. Do not drive sheeting within 100 feet of concrete less than seven (7) days old.
- D. Carry out program of excavation support in such a manner as to prevent undermining or disturbing foundations of existing structures of work ongoing or previously completed.
- E. Bottom of the trench box excavation support system shall be above utility pipe invert prior to installing utility pipes.
- F. Install and collect data from geotechnical instrumentation in accordance with the excavation support plan and Section 310930. Notify the Construction Manager immediately if any geotechnical instrumentation is damaged. Repair or replace damaged geotechnical instrumentation at the discretion of the Construction Manager and at no additional expense to the DEP.
- G. Continuously monitor movements of the ground adjacent to excavation support systems and adjacent structures. In events of the measured movements approaching or exceeding the allowable alert limits, take immediate corrective actions to stop further movement by revising procedures such as providing supplementary bracing, filling voids behind the trench box, supporting utilities, or other measures (Construction Contingency Plan).
- H. Notify utility owners if existing utilities interfere with the excavation support system. Modify the existing utility with the utility owner's permission or have the utility owner make the modifications at Contractor's expense.

3.02 MONITORING ADJACENT TO EXCAVATION SUPPORT SYSTEMS

- A. Notify the Construction Manager when the response limits are exceeded, in accordance with Section 310930.
- B. Implement Construction Contingency Plan under direction of the temporary excavation support system designer and the Construction Manager.

3.03 REMOVAL OF EXCAVATION SUPPORT SYSTEMS

- A. In Jersey City, sheeting for utility excavations for water main or service work shall be left in place.
- B. Elsewhere, sheeting shall not be left in place unless otherwise indicated by the Construction Manager.
- C. When indicated, remove the excavation support system without endangering the constructed or adjacent structures, utilities, or property. Immediately backfill all voids left or caused by withdrawal of excavation support systems with bank-run gravel, screened gravel or select borrow by tamping with tools specifically adapted for that purpose.
- D. Any excavation support system left-in-place shall be cut-off a minimum of 2 feet below the bottom of the next higher foundation level or a minimum of 5 feet below finished grade, as approved by the Construction Manager.
- E. Conduct survey of the locations and final cut-off elevations of the excavation support systems left in place.

3.04 CLEANING UP

- A. After the completion of the excavation support system work, the Contractor shall cleanup work area in accordance with Section 017423.

3.05 CONTRACT CLOSEOUT

- A. Provide in accordance with Section 017700.

END OF SECTION 315000

NO TEXT ON THIS PAGE

SECTION 316216 - STEEL PILES

PART 1 - GENERAL

1.01 DESCRIPTION

- A. Provide and install steel H-piles and perform load inspection and tests as indicated and specified.
- B. This work shall consist of furnishing all materials, products, accessories, tools, equipment, services, transportation, labor, supervision, and manufacturing techniques required for testing and installation of steel H-piles described herein and as shown on the Contract Drawings.
- C. The Contractor is responsible for the implementation of the specified test pile program.
- D. Vibration and Noise monitoring for pile installation operations shall be performed in accordance with Section 023214.

1.02 PAYMENT

- A. No separate payment shall be made for performing any Work required under this Section unless noted otherwise. All costs for Work required by this Section shall be included in the applicable lump sum, unit price(s), or allowance(s) as set forth in Section 012901.

1.03 REFERENCES

- A. Unless otherwise noted, the latest edition of the following codes and standards shall govern this work. If any conflicts exist between these codes and standards the more restrictive requirements shall govern.
- B. The American Institute of Architects (AIA).
- C. American Society for Testing and Materials International (ASTM):
 - 1. A6/A6M: Standard Specification for General Requirements for Rolled Structural Steel Bars, Plates, Shapes, and Sheet Piling.
 - 2. A36/A36M: Standard Specification for Carbon Structural Steel.
 - 3. A252: Standard Specification for Welded and Seamless Steel Pipe Piles.
 - 4. A690/A690M: Standard Specification for High-Strength Low-Alloy Steel H-Piles and Sheet Piling for Use in Marine Environments.
 - 5. D1143: Method of Testing Piles Under Static Axial Compressive Load.

6. D3689: Method of Testing Individual Piles Under Static Axial Tension Load.
 7. D3966: Test methods for Deep Foundations Under Lateral Load.
 8. D4945: Standard Test Method for High-Strain Dynamic Testing of Deep Foundations.
 9. E329: Standard Specification for Agencies in the Testing and/or Inspection of Materials Used in Construction.
- D. American Welding Society (AWS)
1. D1.1: Structural Welding Code.
 2. D1.5: Bridge Welding Code.
- E. The Society for Protective Coatings (SSPC)
1. PA-1: Shop, Field, and Maintenance Painting of Steel.
 2. PA-2: Measurement of Dry Paint Thickness with Magnetic Gauges.
 3. SP-5: White Metal Blast Cleaning.
 4. SP-6: Commercial Blast Cleaning.
 5. Paint-16: Coal Tar Epoxy-Polyamide Black (or Dark Red) Paint
- 1.04 RELATED SECTIONS
- A. General Conditions Article 4.7 – Shop Drawings and Other Submittals
 - B. Section 011414 – Control of Work
 - C. Section 012901 – Measurement and Payment
 - D. Section 014300 - Quality Requirements.
 - E. Section 016100 - Control of Materials.
 - F. Section 017423 - Cleaning Up.
 - G. Section 017700 - Contract Closeout.
 - H. Section 023214 - Vibration and Noise Monitoring.
 - I. Section 310930 – Geotechnical Instrumentation.

1.05 SUBMITTALS

- A. Contractor shall submit the following qualifications in accordance with General Conditions 4.7.
1. Submit the following qualifications ten (10) weeks prior to the installation of Piles:
 - a. Qualifications of Contractor's pile installer, as specified in Paragraph 1.06.C.
 - b. Qualifications of Contractor's Independent Geotechnical Engineering Consultant, as specified in Paragraph 1.06.D.
 - c. Qualifications of Contractor's Independent Testing Laboratory that will load test the steel H-piles, as specified in Paragraph 1.06.E.
 2. Steel Piles:
 - a. Submit data on pile type, size, gauge, treatment and accessories. Data submittal to include a certification by the manufacturer that the piles and pile accessories (i.e., drive points) comply with the ASTM, AWS and SSPC standards listed in Paragraph 1.03.
 - b. Submit fabrication and installation details for piles, including splices and pile tip details.
 3. Pile Driving Plan:
 - a. Submit layout drawings, pile driving sequence and schedule.
 - (1) Layout drawing shall include pile identifications, driving sequence number, type, size, and pile tip elevations.
 - b. Submit list of equipment and driving accessories proposed for use.
 4. Test Pile Driving Records
 - a. Submit daily test pile driving records within two (2) days of pile installation. Daily records should include the following information:
 - (1) Project name and date
 - (2) Pile driving Contractor
 - (3) Pile location and number
 - (4) Pile type and size

- (5) Type of pile drive cap and drive point used
 - (6) Type, size and speed of hammer used
 - (7) Number of blows per foot penetration
 - (8) Number of blows/inch for last six inches of drive
 - (9) Vertical deviations and horizontal offsets
 - (10) Elevations of splices
 - (11) Finished elevations (incl. ground surface, pile tip and cut-off)
 - (12) Effective length left in place
 - (13) Computed pile bearing capacity
 - (14) Unusual occurrences and conditions
5. Pile load test details including: layout, equipment, instrumentation, and load reaction for static tests; high and low strain dynamic load test, equipment, and typical interpretation methods of each test results.
6. Pile Load Test Results - Submit the following data:
- a. Submit load test results within three (3) days of pile testing. Daily records should include the following information:
 - (1) Project Name and date
 - (2) Load Test Type
 - (3) Name of testing laboratory technician
 - (4) Name and signature of supervising geotechnical consultant
 - (5) Pile location and number
 - (6) Pile dimensions
 - (7) Weather Conditions
 - (8) Description of load application apparatus, including jack capacity
 - (9) Description of test instrumentation

- (10) Time, load and movement readings
 - (11) Calibration data
 - (12) Groundwater level
 - (13) Unusual occurrences and conditions
7. Monitoring data within one (1) day of data collection from vibration and noise recording equipment in accordance with Section 023214.
 8. Record drawings showing the actual locations of all piles and their deviations from their design locations.

1.06 QUALITY ASSURANCE

- A. Comply with the requirements specified in Section 014300.
- B. Perform work in accordance with issued permits, Municipalities (City of Hoboken, City of Jersey City, and Township of Weehawken) and the State of New Jersey, ordinances, and regulations.
- C. Steel Pile Installer Qualifications:
 1. Not less than three (3) years' experience in the installation of H-piles in similar conditions and of equal complexity as the proposed system.
 2. Completed not less than five (5) successful steel pile driving projects of similar scope and magnitude as the proposed system within the past ten (10) years.
 3. Pile driving operators and on-site supervisors with not less than three (3) years of experience installing H-piles.
 4. Welders are to be AWS certified and licensed in the State of New Jersey. Proof of licensure will be required at the site.
- D. Independent Geotechnical Consultant Qualifications:
 1. Contractor shall engage an Independent Geotechnical Consultant specializing in geotechnical engineering responsible for designing and monitoring test piles, static pile load tests, and production piles, conducting high strain dynamic pile load tests. Independent Geotechnical Consultant shall be a State of New Jersey licensed Professional Engineer
 2. Consultant shall have not less than five (5) years of experience related to pile installation, pile instrumentation, and pile testing.

3. Consultant's field representative shall have at least three (3) years supervisory experience in pile installation construction and monitored not less than five (5) similarly designed pile load tests.

E. Independent Testing Laboratory:

1. The Contractor shall engage an independent testing laboratory to be responsible for field testing, inspection, and certified reports.
2. Independent testing laboratory shall submit pile load test procedure details four (4) weeks prior to the start of pile operations and submit final reports in accord with Paragraph 1.05 A.6.

F. The peak particle velocity during pile driving operations, shall meet the requirements in accordance with Section 023214.

G. The noise above ambient levels produced from pile driving operations, shall conform to noise regulations in accordance with Section 023214.

H. All welding shall be performed in accordance with AWS D1.1.

1.07 DELIVERY, STORAGE AND HANDLING

A. Comply with the requirements specified in Section 016100.

B. Deliver piles to Project site in such quantities and at such times to ensure continuity of installation. Handle and store piles at location to prevent abrasions, physical damage and distortion.

1. Protect shop-coated finishes during handling and storage by using slings and blocking.
 - a. Touch-up abraded surfaces with coating material that is identical to shop-coating.

1.08 SITE CONDITIONS

A. Protect structures, underground utilities, and other construction from damage caused by pile driving.

B. Geotechnical Investigation Results Report: The report is for information only, which is part of the Contract Documents.

C. The boring logs are included as an appendix in the report and indicate subsurface conditions encountered at only the borehole location. This report shall not be construed as to guarantee that other subsurface materials will not be present or that proportions of

materials will not vary from that shown on the boring logs. The borehole locations and soil profiles are part of the Contract Drawings.

- D. As specified in Section 310930, the Contractor is responsible for the installation and monitoring of geotechnical instrumentation (deformation monitoring points, observation wells/piezometers, etc.) during the entire construction period.

PART 2 - PRODUCTS

2.01 STEEL PILES

- A. H-Piles: H-piles shall be coated, and which conform to ASTM A572, Grade 50.
- B. Installed H- Piles shall be as described:
 - 1. Grade: 50
 - 2. Surface Preparation and Protective Coating: All H-piles shall be coated with coal tar epoxy as per Section 099702.
 - 3. Allowable Design Load:
 - a. The allowable design loads shall be as shown on the Contract Drawings.
 - 4. Pile Dimensions:
 - a. Shall meet the requirements of the Contract Drawings.
 - 5. Welds for splices and pile points: Per AWS A5.1 and A5.5.

2.02 STEEL PILE ACCESSORIES

- A. Pile Points: Manufactured one-piece cast steel driving points capable of bearing the full impact of hammering in the anticipated subsurface materials.
- B. Splices: Manufactured pile splicer comprised of same material as pile and shaped to encase mated pile ends.
- C. Accessories Manufacturers: Associated Pile Fittings Corp., Clifton, New Jersey; Versa-Steel, Inc., Portland, Oregon; J.C. MacElroy Co., Inc., New York, New York or approved equal.

2.03 STEEL PILE FABRICATION

- A. Fabricate and assemble piles in shop to greatest extent possible.

- B. Fabricate full-length piles to minimize splicing during driving.
- C. Fabricate full-length piles by splicing pile lengths together. Maintain axial alignment of pile lengths. Maintain structural properties of pile across splice.
 - 1. Splice Coupling: Fit splice coupling into position and weld to adjoining steel pipe pile sections according to manufacturer's written instructions and AWS D1.1/D1.1M for procedures, appearance and quality of welds, and methods used in correcting welding work.
 - 2. Welded Splices: Accurately mill meeting ends of steel pipe piles and bevel for welding. Continuously weld pile according to AWS D1.1/D1.1M for procedures, appearance and quality of welds, and methods used in correcting welding work.
 - 3. Splice piles during fabrication or field installation.
- D. Pile Points: Fit and fasten driving points to pile tips in accordance with manufacturer's written instructions.
- E. Pile Butts: Cut pile butt perpendicular to longitudinal axis of pile before seating driving cap.
- F. Protective Coating: Treat field cuts, abrasions, holes, welds, splicers, pile points and other penetrations in accordance with SSPC standards and as specified. Allow coating to cure before driving pile.
- G. Pile Markings: Mark each pile with horizontal lines at 12-inch intervals; label the distance from pile tip at 60-inch intervals. Maintain markings on piles until driven to full depth.
- H. Cut the top of the steel pile perpendicular to its longitudinal axis at the specified elevation.

PART 3 - EXECUTION

3.01 PREPARATION

- A. Pile-driving operations shall not start until earthwork fills have been completed or all utilities have been exposed.
- B. Pile-driving or pile load testing shall not start without the presence of the Contractor's Independent Geotechnical Consultant.
- C. Pile-driving or pile load testing shall not start before all vibration/noise monitoring and geotechnical instrumentation has been installed and baseline data has been collected.

Continuously monitor vibration, noise, and adjacent structures during all pile-driving operations.

- D. Assist the Construction Manger to provide written notifications to adjacent and affected landowners and building occupants a minimum of two (2) weeks prior to the start of pile driving efforts.
- E. Avoid drilling pilot holes to facilitate driving unless piling cannot be installed in the specified manner.
 - 1. Drill only through obstructing strata.
 - 2. Drilled hole diameter shall not be more than 1 inch larger than the pile width.
- F. Take protective measures that will prevent damage to nearby properties and structures.
- G. Provide Daily Monitoring reports in accordance with Section 310930.

3.02 DRIVING EQUIPMENT

- A. Pile Hammer: Hammer shall be capable of consistently delivering adequate peak-force duration and magnitude to develop the ultimate capacity required for type and size of pile driven and character of subsurface material anticipated.
- B. Hammer Cushions and Driving Caps: Between hammer and top of pile, provide hammer cushion and steel driving cap as recommended by hammer manufacturer to drive pile without damage.
- C. Leads: Use fixed or semi-fixed pile-driver leads that will hold full length of pile firmly in position and in axial alignment with hammer.

3.03 TEST PILES

- A. Drive test piles in locations as shown on Contract Drawings or indicated by the Construction Manager.
 - 1. Test piles shall be long enough to meet the load testing acceptance criteria specified in Paragraph 3.04.B.
 - 2. Drive test piles identical to the specified pile requirements described in Paragraph 2.01.
 - 3. Drive test piles using the same equipment and under similar conditions to that of the production piles.

3.04 STATIC LOAD TESTS

- A. Perform static load tests on test piles as shown on the Contract Drawings or as selected by the Construction Manager to verify driving criteria and to confirm allowable design load of piles.
 - 1. Wait a minimum of seven days between the end of the test pile installation and pile load testing during Construction Manager’s review.
 - 2. Materials and equipment for testing, testing procedures, and record keeping shall be provided in accordance with ASTM D1143, D3689, and D3966.
 - 3. Test the compressive load of each pile in accordance with ASTM D1143.
 - 4. After completing compression load testing, test the tensile load of each test pile in accordance with ASTM D3689.
 - 5. Test the lateral load of each test piles in accordance with ASTM D3966.
- B. Acceptance Criteria.
 - 1. The test load shall be the load acting on the test pile, when the lesser of the following criteria are met:
 - a. Net settlement, after deducting rebound, of not more than 0.01 inch/ton of test load.
 - b. Total settlement exceeds the pile elastic compression by 0.15 inch, plus 1.0 percent of the tip diameter dimension.
 - c. A plunging failure or sharp break in the load settlement curve.
- C. Test piles that comply with requirements and location tolerances may be used on Project.

3.05 DYNAMIC LOAD TESTS

- A. Perform high-strain dynamic testing on production piles as shown on the Contract Drawings during initial driving and re-striking to determine the force and velocity response of the pile during an axial impact event.
 - 1. Materials and equipment for testing, testing procedures and record keeping shall be provided in accordance with ASTM D4945.

3.06 PRODUCTION PILES

- A. Continuously drive piles to elevations or penetration resistance determined during load testing. Establish and maintain axial alignment of leads and piles before and during driving.
- B. Re-drive heaved piles to tip elevation at least as deep as original tip elevation with a driving resistance at least as great as original driving resistance.
- C. Drive piles without exceeding the following tolerances, measured at pile heads:
 - 1. Location: Maximum of four (4) inches from designated location after pile driving is completed.
 - 2. Deflection: Less than 2 percent from vertical.
 - 3. Batter Angle: Maximum 2 percent deflection from required angle, measured when pile is aboveground in leads.
 - 4. Cut-off Elevation: Maximum 0.02 feet from specified cut-off elevation.
- D. If the load on any pile exceeds 110 percent of the specified load capacity, correct by installation of additional replacement piles, or other procedures approved by the Construction Manager.
- E. Withdraw damaged or defective piles and piles that exceed driving tolerances and install new replacement piles within driving tolerances.
 - 1. Fill holes left by withdrawn piles using cohesionless soil material such as gravel, and gravel-sand mixtures. Place and compact in lifts not exceeding 24 inches.
- F. Abandon and cut off rejected piles as indicated by Construction Manager. Leave rejected piles in place and install new piles in locations as directed by Construction Manager.
- G. Cut off tops of driven piles perpendicular to their longitudinal axis and at elevations indicated.
- H. Remove and legally dispose offsite the withdrawn and cutoff pile sections. Cut off sections are the property of the Contractor.

3.07 FIELD QUALITY CONTROL

- A. Contractor's Independent Geotechnical Engineering Consultant and Independent Testing Laboratory perform daily oversight, tests and inspection of driven pile installations.
- B. Tests and Inspections:

1. Weld Testing: In addition to visual inspection, welds shall be tested and inspected according to AWS D1.1/D1.1M and the inspection procedures listed in subparagraphs below, at testing agency's option. Correct deficiencies in Work that test reports and inspections indicate does not comply with the Contract Documents.
 - a. Liquid Penetrant Inspection: ASTM E 165.
 - b. Magnetic Particle Inspection: ASTM E 709; performed on root pass and on finished weld. Cracks or zones of incomplete fusion or penetration will not be accepted.
 - c. Radiographic Inspection: ASTM E 94; minimum quality level "2-2T."
 - d. Ultrasonic Inspection: ASTM E 164.
- C. Special Inspections and Testing: The DEP may engage qualified special inspectors to perform oversight of driven pile installations, inspections, and testing performed by the Contractor and its geotechnical consultant and testing agency procedures and reporting protocols. The Contractor to provide testing agency access to the work as required.

3.08 REJECTED PILES

- A. A sudden decrease in driving resistance which cannot be correlated with subsurface data or pile driving event may be a cause for rejection as determined by the Construction Manager, unless pile is removed for inspection and found to be undamaged.
- B. When any pile exceeds the installation tolerances specified in Paragraph 3.06 "PRODUCTION PILES", it may be rejected as directed by the Construction Manager.
- C. When any driven pile has been so damaged in driving (due to causes other than obstructions encountered) as to be, in the opinion of the Construction Manager, unsuitable, or otherwise does not conform with the requirements of the Contract, such piles shall be rejected.

3.09 WITHDRAWN PILES

- A. Piles driven in locations, other than in the permanent work, shall be removed, with the approval of the Construction Manager, after completion of driving. Such piles, if undamaged, may be reused at the approval of the Construction Manager.

3.10 CLEANING UP

- A. After the completion of pile installation work, the Contractor shall cleanup work area in accordance with Section 017423.

3.11 CONTRACT CLOSEOUT

- A. Provide in accordance with Section 017700.

END OF SECTION 316216

NO TEXT ON THIS PAGE

SECTION 316323 – MICROPILES

PART 1 GENERAL

1.01 DESCRIPTION

- A. Provide and install micropiles as shown on the Contract Drawings.
- B. This work shall consist of furnishing all materials, products, accessories, tools, equipment, services, transportation, labor, supervision, and manufacturing techniques required for testing and installation of micropiles and pile-top attachments described herein and as shown on the Contract Drawings.
- C. The Contractor shall install a micropile system that will provide the allowable load as indicated on the Contract Drawings. The micropile allowable load shall be verified by testing as required and specified herein.
- D. The Contractor may submit an alternative design that meets the design and performance requirements stated herein. The Contractor will be required to submit working drawings, calculations, installation procedures, and specifications to the Architect/Engineer for review. No micropile work shall commence unless approved by the Construction Manager.
- E. The Contractor or the Contractor's micropile subcontractor shall be fully experienced in all aspects of micropile design and construction, and shall furnish all necessary plant, materials, skilled labor, and supervision to carry out the contract. The Contractor shall provide the Architect/Engineer details of at least five (5) projects successfully completed in the previous five (5) years of similar scope and size. He must also provide resumes of key personnel who will be present on site (and will be materially involved) and who will each have at least three (3) years of relevant experience. These personnel include superintendent, driller, and project engineer/manager. The superintendent shall have completed at least five (5) similar projects.

1.02 PAYMENT

- A. No separate payment shall be made for performing any Work required under this Section unless noted otherwise. All costs for Work required by this Section shall be included in the applicable lump sum, unit price(s), or allowance(s) as set forth in Section 012901.

1.03 REFERENCES

- A. Unless otherwise noted, the latest edition of the following codes and standards shall govern this work. If any conflicts exist between these codes and standards the more restrictive requirements shall govern.

B. American Association of State Highway and Transportation Officials (AASHTO)

1. LRFD Bridge Design Specification 2017.
2. M 31 Specification for Deformed and Plain Billet Steel Bars for Concrete Reinforcement.
3. M 45 Specification for Aggregate for Masonry Mortar.
4. M 80 Specification for Concrete Aggregates.
5. M 85 Specification for Portland Cement.
6. M 194 Specification for Chemical Admixtures for Concrete.
7. M 252 Specification for Polyethylene Corrugated Tubing.
8. M 275 Specification for Uncoated High Strength Bar for Prestressing Concrete.
9. T 26 Quality of Water to be Used in Concrete.
10. T 106 Compressive Strength of Hydraulic Cement Mortar.

C. American Society for Testing and Materials International (ASTM)

1. A36: Standard Specification for Structural Steel.
2. A 252: Standard Specification for Welded and Seamless Steel Pipe Piles.
3. C33: Standard Specification for Concrete Aggregates.
4. C150: Standard Specification for Portland Cement.
5. C494: Standard Specification for Chemical Admixtures for Concrete.
6. A572: Standard Specification for Structural Steel.
7. A 775: Standard Specification for Epoxy-Coated Reinforcing Steel Bars.
8. A 934: Standard Specification for Epoxy-Coated Prefabricated Steel Reinforcing Bars.
9. D 1143: Standard Test Method for Piles Under Static Axial Compressive Load.
10. D 1784: Polyvinyl Chloride (PVC) Pipe (Class 13464-B).

11. D 3689: Standard Test Method for Individual Piles Under Static Axial Tensile Load.
 12. D3966: Test methods for Deep Foundations Under Lateral Load.
- D. American Petroleum Institute (API)
1. 5CT (N-80): Specification for Casing and Tubing.
- E. American Welding Society (AWS)
1. D.1.1: Structural Welding Code – Steel.
 2. D.1.2: Structural Welding Code - Reinforcing Steel.
- F. American Concrete Institute (ACI)
1. 315: Details and Detailing of Concrete Reinforcement.
- 1.04 RELATED SECTIONS
- A. General Conditions Article 4.7 – Shop Drawings and Other Submittals
 - B. Section 011414 – Control of Work.
 - C. Section 012901 – Measurement and Payment.
 - D. Section 014300 - Quality Requirements.
 - E. Section 016100 - Control of Materials.
 - F. Section 017423 - Cleaning Up.
 - G. Section 017700 - Contract Closeout.
 - H. Section 023214 - Vibration and Noise Monitoring.
 - I. Section 099702 – Coal Tar Epoxy
 - J. Section 310930 – Geotechnical Instrumentation.
- 1.05 DEFINITIONS
- A. Micropiles: defined as cast-in-place drilled piles.

1.06 SUBMITTALS

- A. Submit the following Qualifications in accordance with General Conditions Article 4.7.
 - 1. Qualifications of Contractor’s micropile installer, as specified in Paragraph 1.07.C.
 - 2. Qualifications of independent Geotechnical Engineering Consultant, as specified in Paragraph 1.07.D.
 - 3. Qualifications of independent Testing Laboratory responsible for load testing the micropiles, as specified in Paragraph 1.07.E.

- B. Submit the following shop drawings in accordance with General Conditions Article 4.7.
 - 1. The Contractor shall prepare working drawings and relevant structural design calculations for the micropile system for submittal to the Architect/Engineer for review. The submittal shall be stamped by a Licensed Professional Engineer in the State of New Jersey. The Contractor shall allow the Architect/Engineer 20 working days to review the working drawing submittal after a complete set has been received. Work shall not begin until the appropriate submittals have been received, reviewed, and accepted in writing by the Architect/Engineer.
 - 2. The working drawings and design calculations shall include, but not limited to, the following:
 - a. Micropile details for each pile type (load) showing:
 - i. Micropile Design Load,
 - ii. Type and Size of Permanent Casing and Reinforcing Steel,
 - iii. Minimum Total Bond Length,
 - iv. Total Micropile Length, and
 - v. Micropile Top Attachment.
 - b. Reinforcing steel details, including but not limited to, the following:
 - i. All micropile components, associated hardware and connection details
 - ii. Mill test reports for all materials, indicating ultimate strength, modulus of elasticity and percent of elongation at rupture of steel

- iii. Centralizer type and locations
- iv. Method of temporarily supporting the steel during grout placement.
- c. Micropile numbering system for records.
- d. Grout mix designs, and the procedure for placing the grout. Include documentation indicating proposed mix design has been successfully used for similar installations. Include air entrainment if environment requires usage. Previous mix data shall include all admixtures proposed for this project.
- e. Details of equipment and procedures for micropile installation including, but not limited to, consecutive steps and the approximate time required for each step.
- f. Procedures for advancing through the soil, boulders, and other obstructions encountered during drilling.
- g. Methods to be used to control and verify pile position and alignment.
- h. Procedures for control and removal of all spoil.
- i. Shop drawings shall show the required working areas as site conditions warrant for installing the micropiles at the locations shown on the Contract Drawings.
- j. Procedures and equipment for placing grout.
- k. Details for post-grouting including the method, procedure, and equipment to be used.
- l. Layout drawings showing the proposed sequence of micropile installation. Coordinate this sequence with the proposed staging and scheduling.
- m. Methods to flush the drilled hole and methods and equipment for measuring volumes of grout placed in each hole.
- n. Include details of placement, splicing and centralizers for steel reinforcing.
- o. Detailed plans for the method proposed for the testing of the micropiles prior to beginning the tests. This shall include all necessary shop drawings and details to clearly describe the method.
- p. Plan describing how surface water, drill flush, and excess waste grout will be controlled and disposed.

3. The grout mix design, documentation from an independent testing laboratory, and the procedures for placing the grout for review by the Construction Manager before use.
 4. The manufacturer's information, model, size, and type of equipment to be used for installing micropiles with appropriate manufacturer's literature for review by the Construction Manager.
- C. Submit the following construction records in accordance with General Conditions Article 4.7.
1. The certified mill test reports, properly marked, for the reinforcing steel, as the materials are delivered, to the Construction Manager for review. The ultimate strength, yield strength, elongation, and material properties composition shall be included. For steel pipe used as permanent casing, the Contractor shall submit a minimum of two (2) representative coupon tests or mill certifications (if available) on each load delivered to the project.
 - a. Test results for permanent casing.
 2. Calibration reports for each test jack, pressure gauge and master pressure gauge to be used. The calibration tests shall have been performed within 60 calendar days of the date submitted.
 3. Within three (3) working days after any drilled micropile has been deemed to be permanently obstructed or when an installed micropile has been observed to exceed the specified tolerances, provide to the Construction Manager a sketch showing the as-drilled location of all completed micropiles immediately adjacent to the obstructed micropile. Reference all as-drilled locations to established construction lines as shown on the Contract Drawings.
 4. Within one (1) week after completion of all micropiles, provide the Construction Manager with a drawing, sealed by a surveyor registered in the State of New Jersey, showing the designation number of all micropiles and as-drilled location with respect to the specified tolerances. Reference all as-drilled locations to established building lines as shown on the Contract Drawings.
- D. Submit the following installation records in accordance with General Conditions Article 4.7.
1. The installation records for each micropile installed for review by the Architect/Engineer. The records shall be submitted within 24 hours after installation is completed for each micropile. The records shall include, but not limited to, the following minimum information:

- a. Pile number designation.
 - b. Pile materials and dimensions.
 - c. Elevation of top of pile.
 - d. Elevation of the top of the bond length.
 - e. Bond Length.
 - f. Pile drilling duration.
 - g. Final tip elevation.
 - h. Cut-off elevation.
 - i. Design load capacity.
 - j. Description of unusual installation behavior or conditions.
 - k. Grout pressures attained.
 - l. Post-grouting details, if required.
 - m. Grout quantities pumped.
 - n. Time required for each operation.
- E. Upon the completion of the micropile installation for each structural wall section, as-built drawings showing the location of the piles, their depth shall be prepared and submitted.

1.07 QUALITY ASSURANCE

- A. Comply with the requirements specified in Section 014300.
- B. Perform work in accordance with issued permits, Municipalities (City of Hoboken, City of Jersey City, and Township of Weehawken) and the State of New Jersey, ordinances, and regulations.
- C. Micropile Installer Qualifications:
 1. Not less than three (3) years' experience in the installation of micropiles in similar conditions and of equal complexity as the proposed system.

2. Completed not less than five (5) successful micropile drilling projects of similar scope and magnitude as the proposed system within the past ten (10) years.
3. Drill rig operators and on-site supervisors with not less than three (3) years of experience installing micropiles.
4. Welders are to be AWS certified and licensed in the State of New Jersey. Proof of licensure will be required at the site.

D. Independent Geotechnical Consultant Qualifications:

1. Contractor shall engage an Independent Geotechnical Consultant specializing in geotechnical engineering responsible for designing and monitoring test piles, static pile load tests, and production micropiles. Consultant shall be a State of New Jersey licensed Professional Engineer
2. Not less than five (5) years of experience related to micropile installation, micropile instrumentation, and micropile testing.
3. Consultant's field representative shall have at least three (3) years supervisory experience in micropile installation construction and monitored not less than five (5) similarly designed pile load tests.

E. Independent Testing Laboratory:

1. The Contractor shall engage an independent testing laboratory to be responsible for field testing, inspection, and certified reports.
2. Independent testing laboratory shall submit pile load test procedure details four (4) weeks prior to the start of pile operations and submit final reports in accord with Paragraph 1.05 A.6.

F. Special Inspections and Testing: The DEP may engage qualified special inspectors to perform oversight of driven pile installations, inspections, and testing performed by the Contractor and its geotechnical consultant and testing agency procedures and reporting protocols. The Contractor to provide testing agency access to the work as required.

1.08 DELIVERY, STORAGE, AND HANDLING

- A. Comply with requirements specified in Section 016100.
- B. Deliver all micropile materials to the site in such quantities and at such times to ensure continuity of installation. Handle and store micropile materials as to prevent physical damage.

1.09 SITE CONDITIONS

- A. Geotechnical Investigation Results Report: The report is for information only, which is part of the Contract Documents.
- B. The boring logs are included as an appendix in the report and indicate subsurface conditions encountered only at the borehole location. This report shall not be construed as to guarantee that other subsurface materials will not be present or that proportions of materials will not vary from that shown on the boring logs. The borehole locations and soil profiles are part of the Contract Drawings.
- C. As specified in Section 310930, the Contractor is responsible for the installation and monitoring of geotechnical instrumentation (deformation monitoring points, observation wells/piezometers, etc.) during the entire construction period.

1.10 DESIGN AND PERFORMANCE CRITERIA

- A. Micropile Design:
 - 1. The micropiles shall be designed to meet the specified loading as shown on Contract Drawings or specified herein. Design of the micropiles and pile top to footing connections shall use the Service Load Design (SLD) procedures as specified in the FHWA “Micropile Design and Construction Guidelines Manual”, Report No. FHWA-SA-97-070. The required geotechnical safety factors (for SLD Design) shall be in accordance with the FHWA manual, unless specified otherwise. Estimated soil design shear strength parameters, unit weights, applied foundation loadings, slope and external surcharge loads, corrosion protection requirements, known utility locations, easements, right-of-ways, and other applicable design criteria will be as shown on the Contract Drawings or specified herein. Structural design of any individual micropile structure elements not covered in the FHWA manual shall be by the service load design method in conformance with appropriate articles of the most recent edition of the AASHTO Standard Specifications for Highway Bridges, including current interim specifications. Any proposed alternatives that do not meet the design and performance criteria shall not be approved by the Construction Manager. The calculations and drawings required from the Contractor shall be submitted to the Construction Manager for review and acceptance in accordance with this Section. Steel pipe used for external encasement for micropiling shall incorporate an additional 1/16-inch thickness of sacrificial steel for corrosion protection.
 - 2. The overall length of a micropile will be selected such that the required capacity is developed by skin friction between grout and competent soils.

3. When required as shown on the Contract Drawings, corrosion protection of the internal steel reinforcing bars, consisting of either encapsulation, epoxy coating, or grout, shall be provided in accordance with this Section. Where permanent casing is used for a portion of the micropile, encapsulation shall extend at least 5 feet into the casing.
- B. Allowable Stresses: The allowable stresses at working load shall not exceed the following values:
1. Compression Loads. The allowable stress on the cement grout shall be 40 percent of the 28-day unconfined compressive strength (UCS). The allowable stress on the steel reinforcing, including permanent steel casing, shall be 47 percent of the minimum specified yield strength. The maximum allowable stress on the steel shall be 80 ksi (this is provided for strain compatibility at ultimate load). The reinforcing steel shall be designed to carry not less than 60 percent of the design compression load.
 2. Tension Loads. The allowable stress on the steel reinforcing shall be 55 percent of the minimum specified yield strength. The allowable tension stress on the cement grout shall be zero.
- C. Micropile Top Attachment: The micropile top attachment shall effectively distribute the allowable design load to the concrete footing, grade beam, and/or pile cap such that the concrete bearing stress does not exceed ACI Building Code and the bending stress in the steel plates does not exceed AISC Allowable stresses for steel members.

PART 2 PRODUCTS

2.01 MATERIALS

- A. Concrete and Grout
1. Water for mixing grout will be potable or shall be tested for use with the cement and results submitted for approval with information required in this Section.
 2. Admixtures shall conform to the requirements of ATM C494. Admixtures which control bleed, improve flowability, reduce water content and retard set may be used in the grout subject to the review and acceptance of the Construction Manager. Expansive admixtures shall only be added to the grout used for filling sealed encapsulations. Accelerators will not be permitted. Admixtures shall be compatible with the grout and mixed in accordance with the manufacturer's recommendations. Their use will only be permitted after appropriate field tests on fluid and set grout properties.

3. All cement shall be Portland cement conforming to ASTM C150 Type II and shall be the product of one (1) manufacturer. If the brand or type of cement is changed during the Project, additional grout mix tests shall be conducted to ensure consistency of quality and performance in situ.
4. If sand-cement grout is used, sand shall conform to ASTM C 144.

B. Structural Steel

1. All reinforcing steel shall be deformed bars in accordance with ASTM A615 Grade 75.
2. Bar couplers, if required, shall develop the ultimate tensile strength of the bars without evidence of any failure.
3. Permanent steel casing/pipe shall meet the Tensile Requirements of ASTM A252, Grade 3, except the yield strength shall be a minimum of 80 ksi as used in the design submittal. New "Structural Grade" (a.k.a. "Mill Secondary") steel pipe without Mill Certification may be used meeting the following:
 - a. Tensile Requirements,
 - b. Free from defects (dents, cracks, tears), and
 - c. Two (2) coupon tests per truckload delivered to the fabricator.
4. Structural steel plates and shapes for pile top attachments shall conform to ASTM A36 or ASTM A572 Grade 50.
5. Centralizers and spacers shall be fabricated from schedule 40 PVC pipe or tube, steel, or material that is non-detrimental to the reinforcing steel. Wood shall not be used. Centralizers and spacers shall be securely attached to the reinforcement; sized to position the reinforcement within 3/8 inch of plan location from center of pile; sized to grout tremie pipe insertion to the bottom of the borehole; and sized to allow grout to freely flow up the borehole and casing and between adjacent reinforcing bars.
6. Encapsulation (double corrosion protection) shall be shop fabricated using high-density, corrugated polyethylene tubing conforming to the requirements of AASHTO M 252 with a nominal wall thickness of 0.8 mm. The inside annulus between the reinforcing bars and the encapsulating tube shall be a minimum of 5 mm and be fully grouted with non-shrink grout.
7. The minimum thickness of epoxy coating applied electrostatically to the reinforcing steel shall be 0.3 mm. Epoxy coating shall be in accordance with

ASTM A 775 or ASTM A 934. Bend test requirements are waived. Bearing plates and nuts encased in the pile concrete footing need not be epoxy coated.

8. Provide a minimum 1-inch grout cover over bare or epoxy coated bars (excluding bar couplers) or minimum 1/2-inch grout cover over the encapsulation of encapsulated bars.
9. For permanent casing/pipe that will be welded, the following material conditions apply:
 - a. The carbon equivalency (CE) as defined in AWS D1.1, Section X15.1, shall not exceed 0.45, as demonstrated by mill certifications.
 - b. The sulfur content shall not exceed 0.05 percent, as demonstrated by mill certifications.
10. For permanent casing/pipe that will be shop or field welded, the following material conditions apply:
 - a. The steel pipe shall not be joined by welded lap splicing.
 - b. Welded seams and splices shall be complete penetration welds.
 - c. Partial penetration welds may be restored in conformance with AWS D1.1.
 - d. The proposed welding procedure certified by a welding specialist shall be submitted for approval.
11. Threaded casing joints shall develop at least the required nominal resistance used in the design of the micropile.
12. When a bearing plate and nut are required to be threaded onto the top end of reinforcing bars for the pile top to footing anchorage, the threading may be continuous spiral deformed ribbing provided by the bar deformations (e.g., Dywidag to Williams continuous threadbars) or may be cut into the reinforcing bar. If threads are cut into a reinforcing bar, the next larger bar number designation from that shown on the plans shall be provide, at no additional cost.
13. Smooth plastic sheathing, including joints, shall be watertight. Polyvinyl chloride (PVC) sheathing shall conform to ASTM D 1784, Class 13464-B.
14. Bar couplers shall be machine threaded to develop the required design strength of the steel reinforcement bar. Welded splices are not allowed.

15. Micropiles shall be coated with coal tar epoxy as per Section 099702.

PART 3 EXECUTION

3.01 PREPARATION

- A. The soil profile as shown on the Contract Drawings and the boring logs contained in the Geotechnical Report (see Article 1.09 of this Section) are for information purposes only and shall not be construed as to guarantee that other subsurface materials will not be present or that proportions of materials will not vary from that shown on the boring logs. The Contractor shall take additional borings as needed to satisfy the Contractor for the micropile design.
- B. The Contractor shall locate all underground utilities prior to start of drilling operations.
- C. If an obstruction is encountered during installation of a micropile that prevents the advancing of the borehole while using rotary percussive eccentric duplex drilling methods, the borehole shall be abandoned and filled with grout. A new micropile shall be drilled at locations to be determined by the Construction Manager.
- D. The Contractor shall protect nearby structures from damage. All methods of protection shall be in accordance with Sections 023214 and 310930. All construction-induced damage shall be repaired to the satisfaction of the Construction Manager at no additional cost to the DEP.
- E. Contractor shall inspect the site to evaluate the conditions affecting the Work. No claim for additional costs will be allowed because of lack of knowledge of any existing conditions discernible from observation at the site, adjoining property, and available sources of information.
- F. Contractor shall visit the site to review all details of the work and working conditions, verify dimensions in the field including headroom and interference from adjacent or existing structures, and shall advise the Construction Manager of any discrepancy before performing any work.
- G. Contractor shall consult Contract Drawings and official records of existing utilities, both surface and subsurface, and excavate test pits at work locations to observe existing conditions and limitations as they apply to this work and its relation to other construction work.
- H. Contractor shall protect existing utilities to remain within the pile installation work zone in accordance with the requirements of authorities having jurisdiction over same. Contractor shall repair or replace any construction-induced damage to the satisfaction of the utility owners and Construction Manager at no additional cost to the DEP.

- I. Prior to design and installation of micropiles, if the Contractor and/or approved micropile subcontractor deemed necessary shall perform additional test boring(s) as required. The test borings shall extend a minimum of 10 feet below the tip elevation of the micropiles. Information and sampling of the soil overburden shall be obtained using standard penetration test techniques and equipment in accordance with ASTM, including ASTM D1587, ASTM D 420 and ASTM D 4220.
 1. The Contractor shall submit the qualifications of the drilling subcontractor to the Construction Manager for approval. The results of the test borings shall be submitted to the Construction Manager for approval prior to any construction and fabrication of materials.

3.02 INSTALLATION

A. Equipment

1. Micropiles shall be installed with approved drilling equipment. The proposed micropile installation equipment and methods shall be subject to the approval of the Construction Manager and approval shall be secured before mobilization. Approval by the Construction Manager shall not relieve the Contractor or micropile subcontractor of his responsibility to provide equipment with sufficient power, downward thrust and torque, materials, and methods to adequately perform the work in a safe, timely, workmanlike manner.
2. Micropile installation equipment shall be capable of installing micropiles with the use of casing. Wet rotary drilling methods shall employ sufficient fluid pressure to provide complete removal of the cuttings from the hole. The Contractor shall provide a weighted bar with slender tip and attached to a thin cable with calibrated depth marker, metal tape, or other approved equipment suitable for confirming the completeness of the final cleaning operations.
3. The Contractor or micropile subcontractor shall provide all equipment, including concrete pumps or tremie pipes required for the placement of concrete into the micropiles in accordance with the Contract Drawings and this Section. The minimum inside diameter of concrete pump lines or the tremie pipe shall be greater than six times the maximum aggregate size.

B. Micropile Installation

1. The micropile installation technique shall be such that it is consistent with the geotechnical, logistical, environmental, and load carrying conditions of the project. The Contractor shall select the drilling method, the grouting procedures, and grouting pressure used for the installation of the micropiles, subject to the approval of the Construction Manager. The Contractor will advance the pile through overburden fill and organic clay to the required depth into competent

soils as determined by the Construction Manager. The entire length of the micropile above the bond zone shall remain cased as the pile is advanced. No external grouting around the casing will be allowed. Upon completion of advancing the casing to the determined pile tip elevation, the internal rods will be withdrawn, and the pile will be filled internally with grout. Once the grout has stabilized in the bond zone, the centralized reinforcing steel is placed.

2. The drilling equipment and methods must provide a cased borehole to the defined nominal diameter, full length, prior to placing grout and reinforcement.
3. Centralizers shall be provided on central equipment. The upper most centralizer shall be located a maximum 5 feet below the cut off level from the top of the micropile and the bottom most centralizer shall be located a maximum of 5 feet from the bottom of the micropile.
4. The central reinforcement steel with centralizers shall be lowered into the stabilized drill holes to the desired depth without difficulty. Partially inserted reinforcing bars shall not be driven or forced into the borehole.
5. The grout should be injected beginning at the lower end of the borehole. The pipe casing shall be filled with a 4000-psi minimum compressive strength grout without voids from bottom to top of micropile.
6. The Contractor shall check pile top elevations and adjust all installed micropiles to the planned elevations.
7. No open hole drilling shall be allowed. Open hole drilling is defined as predrilling the borehole and allowing the hole stand open and uncased until the structural casing is placed in the drill hole.
8. Each drill rig must complete a micropile including placement of grout before beginning drilling of the next micropile.
9. The Contractor shall control and properly dispose of drill flush, and construction related waste, including grout, in accordance with all applicable local codes and regulations. Provide positive control and discharge of all surface water that will affect construction of the micropile installation. Maintain all pipes or conduits used to control surface water during construction. Repair damage caused by surface water at no additional cost. Upon completion of the work, remove surface water pipes or conduits from the site. Alternatively, with the approval of the Construction Manager, pipes and conduit that are left in-place, may be fully grouted and abandoned or left in a way that protects the structure and all adjacent facilities from migration of fines through the pipe or conduit and potential ground loss. Immediately contact the Construction Manager if unanticipated existing subsurface drainage structures are discovered during excavation or

drilling. Suspend work in these areas until remedial measures meeting the Construction Manager's approval are implemented. Cost of remedial measures or repair work resulting from encountering unanticipated subsurface drainage structures will be paid for as extra work.

10. During construction, the Contractor shall observe the conditions vicinity of the micropile construction site on a daily basis for signs of ground heave or subsidence. Immediately notify the Construction Manager if signs of movements are observed. Contractor shall immediately suspend or modify drilling or grouting operations if ground heave or subsidence is observed, if the micropile structure is adversely affected, or if adjacent structures are damaged from the drilling or grouting. If the Construction Manager determines that the movements require corrective action, the Contractor shall take corrective action necessary to stop the movement or perform repairs. When due to the Contractor's methods or operations or failure to follow the specified/approved construction sequence, as determined by the Construction Manager, the costs of providing corrective actions will be borne by the Contractor. When due to differing site conditions, as determined by the Construction Manager, the costs of providing corrective actions will be paid for as extra work.

C. Pile Drilling and Excavation

1. Position and align the drill casing at the bored pile location.
2. Pre-drilling more than one (1) hole in advance of pressure grouting shall not be permitted. Once a micropile is drilled to the proper depth it shall be immediately grouted.
3. Advance the borehole using duplex drilling methods and reverse circulation within the drill casing. Positive circulation or flushing, a method of progressing and cleaning out a borehole for the micropile wherein water is injected into the borehole and returned upward along the outside of the drill casing will not be allowed. The use of air to clean the casing will not be allowed.
4. Perform drilling and excavation in such a manner to prevent collapse of the hole. The drill tool shall be kept no further than 6 inches away from the end of the drill casing at all times. The cutting shoe diameter used for advancing the casing, shall not exceed the outer diameter of the casing plus ¼ inch. Drill fluid and cuttings shall be controlled by diverters, or other methods approved by the Construction Manager, that produce a closed system allowing all drill spoil to be placed in settling tanks for separation of fluid and solids for eventual disposal. It is the Contractor's responsibility to provide drilling methods and equipment capable of attaining the required pile depth and capacity. Use of bentonite or

polymer slurry will not be permitted. The drill casing shall extend to the bottom of the micropile.

5. If obstructions, such as boulders, are encountered during excavation for a pile, progress through them by means of coring, using a tri-cone roller bit, or appropriate timber cutting bit. Use of drop type Impact hammers and blasting will not be permitted.
6. Controlling the procedures and operations to preclude undermining, disturbance, or settlement to adjacent structures or utilities. If any disturbance occurs, halt operations and modify the equipment and/or procedures so that no further disturbance occurs. Repair any disturbance to the satisfaction of the Construction Manager and at no additional cost.
7. Controlling the procedures and operations so as to prevent the soil at the bottom of the borehole from flowing into the borehole. Maintain the fluid level inside the borehole above the ground water level at all times during installation and cleaning out. Monitor and record the rate of fluid flow used to progress the hole.
8. Waste and spoils shall be disposed of in an appropriate manner. Deposition of waste and spoil on local streets and in sewers will not be permitted.

D. Grouting

1. The Contractor shall have means and methods of measuring the grout quality and quantity during the grouting operations. The Contractor shall keep records showing the quantities and test data for inspection by the Construction Manager.
2. Micropiles shall be primary grouted the same day the load transfer bond length is drilled. The Contractor shall use a stable neat cement grout or a sand cement grout with a minimum 28-day unconfined compressive strength of 4000 psi. Admixtures, if used, shall be mixed in accordance with manufacturer's recommendations. The Contractor is totally responsible for the appropriate mix design including, but not limited to, strength, slump, and admixture requirements.
3. The pump shall be equipped with a pressure gauge to monitor grout pressures. The pressure gauge shall be capable of measuring pressures of at least 145 psi or twice the actual grout pressures used by the Contractor, whichever is greater. The grouting equipment shall be sized to enable the grout to be pumped in one continuous operation. The grout should be kept in constant agitation prior to pumping.
4. The grout shall be injected from the lowest point of the drill hole (by tremie methods) until clean, pure grout flows from the top of the micropile. The tremie

grout may be pumped through grout tubes, hollow stem augers, or drill rods. Subsequent to tremie grouting, all grouting operations associated with, for example, extraction of drill casing and pressure grouting, must ensure complete continuity of the grout column. The use of compressed air to directly pressurize the fluid grout is not permissible. The grout pressures and grout takes shall be controlled to prevent excessive heave in cohesive soils or fracturing of soil or rock formations. The entire pile shall be grouted to the design cut-off level.

5. Upon completion of grouting, the grout tube may remain in the hole, but it shall be filled with grout.
6. The grouting equipment shall produce a colloiddally mixed grout free of lumps and undispersed cement. The grouting equipment shall be sized to enable the grout to be pumped in one continuous operation. The mixer shall be capable of continuous agitation of the grout.
7. Grout within the micropiles shall be allowed to attain adequate strength prior to load testing.
8. If the Contractor uses a post-grouting system, all relevant details including grouting pressure, volume, location and mix design, shall be submitted.

3.03 GROUT TESTING

- A. During production, samples selected at random of grout mix shall be taken daily (two (2) sets of six (6) samples per pile). An independent testing firm, hired by the Contractor shall collect and test samples of the grout. Test reports shall be submitted to the Construction Manager within two (2) days of testing.
- B. The 2-inch cube samples shall be molded, cured in a properly constructed curing box supplied by Contractor, tested in accordance with AASHTO T 106, and shall reach a compressive strength after seven days equal to at least 60 percent of the design strength. The compressive strength shall be the average of the three (3) cubes tested.
- C. If this requirement is not met, Contractor shall modify the proportions of the mix subject to the approval of the Construction Manager. If the required design strength is not attained after 28 days, then Contractor shall install replacement pile(s) as required. Any associated work required due to unacceptable piles shall be at no additional cost to the DEP.
- D. The Construction Manager may also require Contractor to modify the mix design if an excessive amount of grout is lost from a pile hole into voids in the in-place materials. Materials shall be accurately measured by weight or volume before mixing.

- E. Each batch of grout shall have the same volume and contain the same whole number of sacks of cement, unless a modification is approved by the Construction Manager. Time of mixing shall be not less than three (3) minutes.
- F. If agitated continuously, the grout may be held in the mixer or agitator for a period not exceeding three hours at temperatures below 21 degrees Celsius and for a period not exceeding two (2) hours at higher temperatures.
- G. If there is a lapse in pumping of the grout, the grout shall be recirculated through the pump or through the mixer drum (or agitator) and pump.
- H. Retempering of grout will not be permitted.

3.04 UNACCEPTABLE PILES

- A. Unacceptable piles are piles that are rejected by the Construction Manager because of damage, failure to advance through obstructions, mis-location, misalignment, failure to meet load test acceptance criteria, failure to install the pile using the approved equipment and procedures, or failure to install the pile to the proper depth. Submit a written plan of action to the Construction Manager for approval, showing how to correct the problem and prevent its reoccurrence. Repair or augment the pile to the satisfaction of the Construction Manager to make it acceptable. To mitigate and/or to remedy unaccepted piles, Contractor may be required to provide additional piles or supplement piles to meet specified requirements. Any associated work required due to unacceptable piles shall be at no additional cost to the DEP.
- B. Allowable Tolerances:
 - 1. Centerline of piling shall not be more than 3 inches from indicated plan position.
 - 2. Pile alignment shall be within 1 percent of design alignment.
 - 3. Top elevation of pile shall be within 2 inches of the design vertical elevation.
 - 4. Centerline of core reinforcement shall not be more than 0.6 inches from centerline of piling.

3.05 STATIC LOAD TESTS

- A. Perform static load tests on production piles as shown on the Contract Drawings or selected by the Construction Manager, in accordance with ASTM D1143, D3689, and D3966.
 - 1. Static Load Tests:

- a. Pile load tests shall be performed on production piles in accordance with the plan to verify the load carrying capacity of the pile system and the construction procedures prior to installing production piles. The location of the pile to be tested is indicated on the Plan. Test pile with reaction piles or anchors shall be constructed prior to the commencement of the installation of the remaining production micropiles.
- b. The micropile load test results shall verify the Contractor's design and will be reviewed and accepted by the Architect/Engineer prior to beginning production micropiles.
- c. The Contractor shall submit for review and acceptance the micropile load-testing program. The testing program submittal shall be provided two (2) weeks prior to starting the load testing. This micropile verification load testing proposal shall indicate the minimum following information:
 - i. Type and accuracy of apparatus for measuring load,
 - ii. Type and accuracy of apparatus for applying load,
 - iii. Type and accuracy of apparatus for measuring the pile deformation,
 - iv. Type and capacity of reaction load system, and
 - v. Hydraulic jack calibration report.
- d. The drilling and grouting methods, casing diameter, and depth of embedment of the test pile shall be identical to the production piles.
- e. The tested micropiles shall be loaded to 200 percent of the compression allowable design load. The jack shall be positioned at the beginning of the test such that the unloading and repositioning of the jack during the test will not be required.
- f. Pile load tests shall be performed in general accordance with ASTM D1143, D3689, and D3966 with modification to reflect micropile design.
- g. During static load testing, backup monitoring shall be performed using piano wire, mirror, and scale at the pile butt, where practical. Survey monitoring shall be included.
- h. Acceptance Criteria
 - i. The test load shall be the load acting on the micropile, when the lesser of the following criteria are met:

- (a) Net settlement, after deducting rebound, of not more than 0.01 inch/ton of test load
 - (b) Total settlement exceeds the micropile elastic compression by 0.15 inch, plus 1.0 percent of the tip diameter dimension.
 - (c) A plunging failure or sharp break in the load settlement curve.
- i. The Contractor's engineer will give the Construction Manager written confirmation concerning micropile construction and the results of the load test within three (3) working days after the completion of the verification load tests. This written confirmation will either confirm the capacities and bond lengths as shown in the drawings for micropiles or reject the piles based upon the results of the verification tests.
 - j. When a micropile fails, the Contractor shall modify the design, the construction procedure, or both. These modifications include, but are not limited to installing replacement micropiles, modifying the installation methods, increasing the bond length, or changing the micropile type. Any modification which requires changes to the structure shall have prior review and acceptance of the Construction Manager. Any modifications of design or construction procedures shall be at the Contractor's expense.
 - k. If the test pile has an Axial Static Load Test and a Tensile Load Test being performed on the same pile, the Axial Static Load Test shall be performed first.

3.06 CLEANING UP

- A. After the completion of the micropile installation work, the Contractor shall cleanup work area in accordance with Section 017423.

3.07 CONTRACT CLOSEOUT

- A. Provide in accordance with Section 017700.

END OF SECTION 316323

NO TEX ON THIS PAGE

SECTION 316623 – COLUMN SUPPORTED EMBANKMENT SYSTEM

PART 1 GENERAL

1.01 DESCRIPTION

- A. Provide design, installation, testing, and monitoring of a Column Supported Embankment System (CSES) as shown on the Contract Drawings (see Sheets CPAGE401 to CPAGE406 and CPGE401 to CPGE406).
- B. This work shall consist of furnishing all materials, products, accessories, tools, equipment, services, transportation, labor, supervision, and manufacturing techniques required for testing and installation of the CSES described herein and as shown on the Contract Drawings.
- C. The Contractor shall submit a complete design that meets the performance requirements stated herein. The Contractor will be required to submit working drawings, calculations, installation procedures, and specifications to the Architect/Engineer for review and evaluation. All working drawings, calculations, installation procedures and specifications are to be signed and sealed by a professional engineer licensed in the State of New Jersey. No work associated with the CSES shall commence unless submittals are reviewed and accepted by the Architect/Engineer.
- D. The Contractor shall be fully experienced in all aspects of CSES design and construction, and shall furnish all necessary plant, materials, skilled labor, and supervision to carry out the contract.

1.02 PAYMENT

- A. No separate payment shall be made for performing any Work required under this Section. All costs for Work required by this Section shall be included in the applicable Cove Park lump sum(s) as set forth in Section 012901.

1.03 REFERENCES

- A. Unless otherwise noted, the latest edition of the following codes and standards shall govern this work. If any conflicts exist between these codes and standards the more restrictive requirements shall govern.
- B. American Association of State Highway and Transportation Officials (AASHTO)
 - 1. LRFD Bridge Design Specification, current edition.
 - 2. M 45 Specification for Aggregate for Masonry Mortar.

3. M 80 Specification for Concrete Aggregates.
 4. M 85 Specification for Portland Cement.
 5. M 194 Specification for Chemical Admixtures for Concrete.
 6. M 252 Specification for Polyethylene Corrugated Tubing.
 7. T 26 Quality of Water to be Used in Concrete.
 8. T 106 Compressive Strength of Hydraulic Cement Mortar.
- C. American Society for Testing and Materials International (ASTM)
1. C33: Standard Specification for Concrete Aggregates.
 2. C150: Standard Specification for Portland Cement.
 3. C494: Standard Specification for Chemical Admixtures for Concrete.
 4. A572: Standard Specification for Structural Steel.
 5. A 775: Standard Specification for Epoxy-Coated Reinforcing Steel Bars.
 6. D 1143: Standard Test Method for Piles Under Static Axial Compressive Load.
 7. D1557: Standard Test Methods for Laboratory Compaction Characteristics of Soil Using Modified Effort (56,000 ft-lb/ft³ (2,700 kN-m/m³)).
 8. D 1784: Polyvinyl Chloride (PVC) Pipe (Class 13464-B).
 9. D 5882: Standard Test Method for Low Strain Impact Integrity Testing of Deep Foundations.
 10. D6637: Standard Test Method for Determining Tensile Properties of Geogrids by Single or Multi-Rib Tensile Method.
 11. D7949: Standard Test Methods for Thermal Integrity Profiling of Concrete Deep Foundations.
- D. American Concrete Institute (ACI)
1. 305: Guide to Hot Weather Concreting
 2. 306: Guide to Cold Weather Concreting

- 3. 315: Details and Detailing of Concrete Reinforcement.
 - E. Occupational Safety and Health Administration (OSHA) Standards and Regulations
 - 1. 29 CFR 1926, Subpart Q: Concrete and Masonry Construction
 - F. U.S. Environmental Protection Agency (EPA):
 - 1. Test Method 9090: Compatibility Test for Wastes and Membrane Liners
 - G. U.S. Department of Transportation Federal Highway Administration (FHWA):
 - 1. FHWA-NHI-16-028, GEC 013, “Ground Modification Methods Reference Manual – Volume II”.
- 1.04 RELATED SECTIONS
- A. General Conditions Article 4.7 – Shop Drawings and Other Submittals
 - B. Section 011414 – Control of Work.
 - C. Section 012901 – Measurement and Payment.
 - D. Section 014300 - Quality Requirements.
 - E. Section 015713 – Erosion Control, Sedimentation, and Containment of Construction Materials.
 - F. Section 016100 - Control of Materials.
 - G. Section 017423 - Cleaning Up.
 - H. Section 017700 - Contract Closeout.
 - I. Section 021600 – Excess Clean Fill, Contaminated Soil, and Groundwater Management.
 - J. Section 023214 - Vibration and Noise Monitoring.
 - K. Section 023219 – Subsurface Utility Locating (potholing)
 - L. Section 031000 – Concrete Formwork
 - M. Section 033000 – Cast-in-place Concrete
 - N. Section 310930 – Geotechnical Instrumentation.

- O. Section 312300 – Excavation and Fill
- P. Section 312319 – Dewatering
- Q. Section 315000 – Excavation Support Systems

1.05 DEFINITIONS

- A. Column Supported Embankment System (CSES): a ground improvement technique for transferring the embankment load through a weak soil strata to the underlying competent stratum.
- B. Rigid Column Inclusion (RCI): the process of forming concrete columns in place by advancing a displacement tool (generally a hollow stem probe) to a specified/required depth, then retracting the displacement tool slowly, at a constant rate, while a concrete mixture is pumped down.
- C. Load Transfer Platform (LTP): A semi-rigid slab that transfers embankment loads to the RCI's, constructed of geosynthetic reinforced with compacted granular soil placed on top.
- D. Utility: The company, agency, or other entity that provides service.

1.06 SUBMITTALS

- A. Submit the following Qualifications in accordance with General Conditions Article 4.7.
 - 1. Qualifications of Contractor's CSES designer, as specified in Paragraph 1.07.C.
 - 2. The Contractor shall prepare working drawings and relevant structural design calculations for the CSES to be submitted to the Architect/Engineer for review and evaluation. The submittal shall be stamped by a Licensed Professional Engineer in the State of New Jersey. The Contractor shall allow the Architect/Engineer 20 working days to review the working drawing submittal after a complete set has been received. Work shall not begin until the appropriate submittals have been received, reviewed, and evaluated in writing by the Architect/Engineer.
 - 3. The working drawings and design calculations shall include, but not limited to, the following:
 - a. Plan Layout and elevation drawings for CSES components:
 - i. Location and spacing of columns,
 - ii. Type and Size of columns,

- iii. Load Transfer Platform (LTP) step elevations with overlaps, and
- iv. Top and bottom elevations of columns and LTP layers.
- b. Geosynthetic reinforcement details, including but not limited to, the following:
 - i. All components, associated hardware and connection details
- c. Column numbering system for records.
- d. Details of equipment and procedures for installation including, but not limited to, consecutive steps and the approximate time required for each step.
- e. Procedures for advancing through the soil, boulders, and other obstructions encountered during drilling/driving.
- f. Methods to be used to control and verify column position and alignment.
- g. Procedures for control and removal of all spoil in accordance with Section 021600.
- h. The concrete mix design and description of materials including water-cement ratio by weight, cement factor, and minimum 28-day compressive strength in pounds per square inch (psi). Provide sufficient details to indicate their compliance with the contract documents, or approved working drawings, including either:
 - i. Laboratory test of trial mixes made with the proposed concrete design mix, or
 - ii. Laboratory tests of proposed concrete design mix used on other projects.
- i. Shop drawings shall show the required working areas as site conditions warrant for installing the CSES at the location shown on the Contract Drawings.
- j. Methods and procedures to perform column core drilling if and where directed by the Architect/Engineer.
- k. Layout drawings showing the proposed sequence of installation. Coordinate this sequence with the proposed staging and scheduling.

1. Detailed plans for the method proposed for the testing of the columns prior to beginning the tests. This shall include all necessary shop drawings and details to clearly describe the method.
4. The manufacturer's information, model, size, and type of equipment to be used for installing the CSES with appropriate manufacturer's literature for review by the Architect/Engineer.
5. Temporary excavation and shoring drawings for worker protection in accordance with Section 315000.
6. Dewatering plan including disposition of groundwater in accordance with Section 312319.
7. Samples and test results of all materials used in the Construction of the CSES, including but not limited to the concrete, geotextiles, and geosynthetic embankment reinforcement. All test results shall be provided to the Architect/Engineer.
8. Calibration reports for each test jack, pressure gauge and master pressure gauge to be used. The calibration tests shall have been performed within 60 calendar days of the date submitted.
9. Within three (3) working days after any drilled/driven column has been deemed to be permanently obstructed or when an installed column has been observed to exceed the specified tolerances, provide to the Architect/Engineer a sketch showing the as-built location of all completed columns immediately adjacent to the obstructed column. Reference all as-built locations to established construction lines as shown on the Contract Drawings.
10. Within one (1) week after completion of all columns, provide the Architect/Engineer with a drawing, sealed by a surveyor registered in the State of New Jersey, showing the designation number of all columns and as-built location with respect to the specified tolerances. Reference all as-built locations to established building lines as shown on the Contract Drawings.
11. A detailed quality control program meeting the requirements as specified herein.
12. Column integrity test report.
13. Within five (5) working days after completion provide the results of the load tests. Should the load test results require modifications to the construction drawings, submit a set of revised drawings, prior to the start of additional work.

- B. Submit the following installation records in accordance with General Conditions Article 4.7.
 - 1. The installation records for each column installed for review by the Architect/Engineer. The records shall be submitted within 24 hours after installation is completed for each column. The records shall include, but not limited to, the following minimum information:
 - a. Column number designation.
 - b. Column materials and dimensions.
 - c. Elevation of top of Column.
 - d. Column drilling duration.
 - e. Final tip elevation.
 - f. Cut-off elevation.
 - g. Design load capacity.
 - h. Description of unusual installation behavior or conditions.
 - i. Time required for each operation.
- C. Upon the completion of the CSES installation, as-built drawings showing the location of the RCI's, their depth, and the extents of the LTP shall be prepared and submitted.

1.07 QUALITY ASSURANCE

- A. Comply with the requirements specified in Section 014300.
- B. Perform work in accordance with issued permits, Municipalities (City of Hoboken) and the State of New Jersey, ordinances, and regulations.
- C. CSES Designer Qualifications:
 - 1. Not less than five (5) years' experience in the installation of column supported embankment systems in similar conditions and of equal complexity as the proposed system.
 - 2. Completed not less than five (5) successful projects of similar scope and magnitude as the proposed system within the past ten (10) years.

- a. The list of experience must include description of project, relative size, date of completion, and contact person with phone number.
 3. On-site supervisors and key personnel with not less than three (3) years of experience installing CSES's.
 4. CSES designer must be a State of New Jersey licensed Professional Engineer experienced in ground improvement techniques and design of column supported embankment systems. A documented record of at least five (5) years of experience in successful design of column supported embankment systems and structures for a minimum of five (5) projects of similar scope and purpose.
- D. Independent Testing Laboratory:
1. The Contractor shall engage an independent testing laboratory to be responsible for field testing, inspection, and certified reports to the CSES designer for acceptance of the installation.

Independent testing laboratory shall have no less than three (3) years' experience performing inspection and testing on Column Supported Embankment Systems for similar applications.

- E. Protect excavations from cave-in of loose soils in accordance with Section 315000.

1.08 DELIVERY, STORAGE, AND HANDLING

- A. Comply with requirements specified in Section 016100.
- B. Deliver all CSES materials to the site in such quantities and at such times to ensure continuity of installation. Handle and store geosynthetic materials as to prevent physical damage.

1.09 SITE CONDITIONS

- A. Geotechnical Investigation Results Report: The report is for information only, which is part of the Contract Documents. The boring logs are included as an appendix in the report and indicate subsurface conditions encountered only at the borehole location. This report shall not be construed as to guarantee that other subsurface materials will not be present or that proportions of materials will not vary from that shown on the boring logs. The borehole locations and soil profiles are part of the Contract Drawings.
- B. At various locations within the project limits, the differing site conditions, soil properties, loading requirements may dictate a variable thickness of the load transfer platform, and a variety of Rigid column inclusion locations, their spacing diameter, and depths.

- C. Geotechnical Design Report for Cove Park: This report provided preliminary design parameters and a basis of design to be used for information only for the Contractor's final design.
- D. As specified in Section 310930, the Contractor is responsible for the installation and monitoring of geotechnical instrumentation (deformation monitoring points, inclinometers, and settlement platforms.) during the entire construction period and a minimum of six (6) months there after

1.10 DESIGN AND PERFORMANCE CRITERIA

- A. The area immediately beneath the load transfer platform shall be free of deleterious materials, and free of loose or otherwise unsuitable materials, prior to the placement of the geogrid reinforcement.
- B. Provide full coverage of the total CSES plan area as shown on the Contract Drawings or as modified by the Contractor's final design drawings.
- C. CSES Design:
 - 1. The design of the CSES includes support of the specified bearing resistances required for retaining walls within the CSES plan area as shown on the Contract Drawings.
 - 2. Nominal and factored soil bearing resistance must be optimized beneath all components of the embankment and retaining walls to meet the required settlement criteria.
 - 3. Design Calculations shall include:
 - a. A minimum factor of safety of 2.25 for the column axial compression capacity of concrete column.
 - b. Soil bearing resistance.
 - c. Short-term and long-term settlement
 - d. Static and seismic global stability including localized stability checks during staged construction. A minimum factor of safety of 1.3 for static and 1.1 for seismic global stability of the embankments support on concrete columns.
 - 4. The Contractor must demonstrate that global stability of the retaining walls, embankment, and CSES ground improvement system is stable for both short and long-term loading conditions.

5. Column axial capacity, soil bearing capacity, and embankment stability analyses must use short term strength parameters for the soil.
 6. Settlement must be assessed using appropriate short and long-term soil parameters including consolidation analysis.
 7. Additional geotechnical data or subsurface soils information needed for CSES design and analysis is the responsibility of the Contractor.
 8. The nominal diameter of the RCI shall not be less than 18 inches unless the Contractor's design calculations show otherwise and approved by the Architect/Engineer. The spacing shall not exceed 10 feet unless approved by the Architect/Engineer.
 9. The RCI configuration consists of a square or triangular grid pattern.
 10. The RCI's extend a minimum depth of 2 times the RCI diameter into the underlying dense and stiff soil stratum unless otherwise designed and submitted by the Contractor and approved by the Architect/Engineer.
 11. Geosynthetic embankment reinforcement within the load transfer platform must develop the required minimum values of tensile strength at a maximum strain equal to 5 percent.
- D. Upon completion of all components of the embankment and retaining walls, ensure localized settlement at the base of the load transfer platform does not exceed 2 inches, and is not reflected at the final subgrade surface.
- E. Post construction long term settlement shall not exceed 1 inch in 10 years.
- F. The maximum differential settlement of the final subgrade surface must not exceed 1/2 inch per 100 feet at completion of the full load condition.
- G. The CSES cannot cause any additional loading on adjacent piles supported foundations.

PART 2 PRODUCTS

2.01 MATERIALS

- A. Concrete
1. Concrete for RCI's shall consist of Portland cement, sand, water, and may also contain coarse aggregate and mineral admixtures.

2. Water for mixing concrete will be potable or shall be tested for use with the cement and results submitted for approval with information required herein.
3. Admixtures shall conform to the requirements of ATM C494. Admixtures which control bleed, improve flowability, reduce water content and retard set may be used in the concrete subject to the review and evaluation by the Architect/Engineer. Expansive admixtures shall only be added to the concrete used for filling sealed encapsulations. Accelerators will not be permitted. Admixtures shall be compatible with the concrete and mixed in accordance with the manufacturer's recommendations. Their use will only be permitted after appropriate field tests on fluid and set concrete properties.
4. All cement shall be Portland cement conforming to ASTM C150 Type II and shall be the product of one (1) manufacturer. If the brand or type of cement is changed during the Project, additional concrete mix tests shall be conducted to ensure consistency of quality and performance in situ.
5. Fine and coarse aggregate shall conform to ASTM C33.
6. Protect concrete from physical damage or reduced strength, which could be caused by frost, freezing actions or low temperatures, or from damage during high temperatures in accordance with ACI 305/306.

B. Geosynthetics

1. The manufacturer's certification shall indicate that the geogrid reinforcement has been evaluated in full compliance with this specification and that the materials meet the full requirements as shown on the plans and as specified herein.
2. The contractor's submittal package shall include; but not be limited to, the following test results:

<u>Property</u>	<u>Test Method</u>
Tensile Strength at 2% Strain	ASTM D6637
Tensile Strength at 5% Strain	ASTM D6637
Ultimate Tensile Strength	ASTM D6637
Resistance to Long Term Degradation	EPA 9090

3. Requirements of the above properties will be as per the approved shop drawing.

C. Reinforcement Fill material

1. The select reinforcement material for the LTP shall meet the following gradation:

Table 316623-1	
Sieve Designation (Square Mesh)	Percentage Passing (By Weight)
2 inches.	100
1-1/2 inch.	95 – 100
1/4 inch.	70 – 92
3/8 inch.	50 – 70
No. 4	35 – 55
No. 30	12 – 25
No. 200	0 - 8

2. As per the United Soil Classification System (USCS), the reinforcement fill material shall be classified as GW or GW-GM.

D. Settlement Platforms

1. Settlement platforms will monitor vertical displacements occurring during and after embankment construction by measuring elevation of top of riser pipe (mounted on the platform) using optical surveying methods.
 - a. Provide threaded 6-inch casing pipe and 3-inch inner pipe according to ASTM A53, welded base, standard weight.
 - b. Provide steel base plate according to ASTM A 36.
 - c. Provide sand base soil aggregate.
 - d. Provide protective base casing as shown in monitoring program.
 - i. The riser(s) will be extended as the fill is placed to maintain the top of the settlement platform between 2 and 4 feet above the average surrounding ground.
 - e. Provide surface protection consisting of a roadway box with locking lid, for settlement platforms installed within publicly accessible areas.

2.02 EQUIPMENT

- A. The Contractor shall provide equipment in good operating condition capable of performing the work specified herein and per the design of the CSES. The Contractor shall ensure a firm base on which the equipment can operate safely under its own

power. If necessary, geotextile stabilization/reinforced working platform will be constructed upon which heavy equipment can be operated.

1. It is the responsibility of the Contractor to design the working platform.
 2. The Contractor shall select a suitable installation rig capable of applying sufficient force and/or torque to penetrate to the required depth based on the provide subsurface conditions.
- B. Concrete shall be placed using positive displacement pump and through suitable tubing. The system shall have a means of determining the volume of grout delivered to the tooling at any time during construction.

PART 3 EXECUTION

3.01 PREPARATION

- A. The soil profile as shown on the Contract Drawings and the boring logs are for information purposes only and shall not be construed as to guarantee that other subsurface materials will not be present or that proportions of materials will not vary from that shown on the boring logs. The Contractor shall take additional borings as needed to satisfy the Contractor for the CSES design.
- B. The Contractor shall locate all underground utilities prior to start of drilling operations.
- C. If an obstruction is encountered during installation of the RCI column that prevents the advancing of the borehole while using rotary percussive eccentric duplex drilling methods, the borehole shall be abandoned and filled with grout. A new RCI column shall be drilled at locations to be determined by the Architect/Engineer.
- D. The Contractor shall protect nearby structures from damage. All methods of protection shall be in accordance with Sections 023214 and 310930. All construction-induced damage shall be repaired to the satisfaction of the Construction Manager at no additional cost to the NJDEP.
- E. Contractor shall inspect the site to evaluate the conditions affecting the Work. No claim for additional costs will be allowed because of lack of knowledge of any existing conditions discernible from observation at the site, adjoining property, and available sources of information.
- F. Contractor shall visit the site to review all details of the work and working conditions, verify dimensions in the field including interference from adjacent or existing structures, and shall advise the Construction Manager of any discrepancy before performing any work.

- G. Contractor shall consult Contract Drawings and official records of existing utilities, both surface and subsurface, and excavate test pits at work locations to observe existing conditions and limitations as they apply to this work and its relation to other construction work.
- H. Contractor shall protect existing utilities to remain within the column installation work zone in accordance with the requirements of authorities having jurisdiction over same. Contractor shall repair or replace any construction-induced damage to the satisfaction of the utility owners and Construction Manager at no additional cost to the NJDEP.
- I. Prior to design and installation of the CSES, if the Contractor and/or approved CSES Designer deemed necessary shall perform additional test boring(s) as required. The test borings shall extend a minimum of 10 feet below the tip elevation of the columns. Information and sampling of the soil overburden shall be obtained using standard penetration test techniques and equipment in accordance with ASTM, including ASTM D1587, ASTM D 420 and ASTM D 4220.
 - 1. The Contractor shall submit the qualifications of the drilling subcontractor to the Architect/Engineer for approval. The results of the test borings and any laboratory tests performed shall be submitted to the Architect/Engineer for review and evaluation prior to any construction and fabrication of materials.

3.02 DESIGN CRITERIA

- A. The design and construction procedures for the CSES shall be in accordance with the Contract Drawings, the specifications, and comply with the procedures in the FHWA “Ground Modifications Methods Reference Manual – Volume II”, Publication No. FHWA-NHI-16-028.
- B. The selection of the sizes and types of the RCI’s shall depend on the magnitude of the loads being supported and the subsurface conditions. A basic outline of the minimum steps required for design are as follows:
 - 1. Structural Performance
 - 2. Geotechnical Capacity
 - 3. Settlement estimation
 - 4. Global Stability
- C. The CSES designer shall submit a complete set of design calculations and construction drawings to the Architect/Engineer, which have been signed and sealed by licensed Professional Engineer of the State of New Jersey.

3.03 INSTALLATION

A. Equipment

1. The RCI's shall be installed with approved drilling equipment. The proposed RCI installation equipment and methods shall be subject to the review and acceptance of the Architect/Engineer and acceptance shall be secured before mobilization. Acceptance by the Architect/Engineer shall not relieve the Contractor or CSES Designer of his responsibility to provide equipment with sufficient power, downward thrust and torque, materials, and methods to adequately perform the work in a safe, timely, workmanlike manner.
2. The Contractor or CSES Designer shall provide all equipment, including concrete pumps or tremie pipes required for the placement of concrete into the RCI columns in accordance with the approved shop drawings and herein. The minimum inside diameter of concrete pump lines or the tremie pipe shall be greater than six times the maximum aggregate size.

B. RCI Installation

1. The RCI installation technique shall be such that it is consistent with the geotechnical, logistical, environmental, and load carrying conditions of the project. The Contractor shall use a process of forming the concrete columns in place with a cement mixture delivered through the center of a displacement auger, or other approved drilling equipment advanced to the required design depth or until the required refusal criteria is satisfied. If the required depth has not been achieved at the time of refusal, predrill to the design depth as approved by the Architect/Engineer. When retracting the displacement tool slowly, at a constant rate, while the concrete mixture is pumped progressively out the bottom of the tool at low pressure to completely fill the displacement hole and achieve full contact with the surrounding soil from the depth required to the working surface grade.
2. The displacement tool shall consist of a hollow stem probe screwed, pushed, or vibrated into the ground to the required depth by equipment with high torque capacity and very high static downward thrust, which displaces the soil laterally with virtually no spoil or excessive vibration. The outside diameter of the displacement tool is equal to the minimum required RCI design diameter. The Field Supervisor must always be present at the work site during CSES operations.
3. All RCI construction shall be performed under the inspection of the Construction Manager's Quality Control Representative (QCR). The QCR shall ensure that the procedures and documentation conform herein. The QCR shall take the following measurements for each RCI: RCI number, start and finish time of

column, depth of treatment, rate of tool penetration with depth, rate of tool withdrawal with depth, and rate of grout delivery to tool with depth.

4. Ensure the appropriate volume of concrete is delivered when the displacement tool is close to the surface and significant positive pressure can no longer be maintained. The completion of the top requires manual work to remove any latency, debris, or contaminated concrete before reinforcement is placed. An auger or placement of temporary formwork shall be used where required, to maintain a consistent top diameter and depth for a full and sound section up to finished grade.
5. Ensure shattering or other damage to the column is avoided when cutting off and trimming columns to the specified cut-off elevation. Cracked or defective concrete shall be saw cut away and the column section repaired or replaced in a satisfactory manner approved by the Architect/Engineer.
6. If the concrete placement in any column cannot be completed in accordance with the approved procedures, then the column must be re-penetrated before the concrete has hardened or completely replaced. Cold joints are not allowed.
7. When required, complete the extension of RCI tops above the existing grade using temporary formwork and hand tools to remove excess concrete, or after initial set, saw cut column top down to remove any questionable or contaminated concrete. Concrete breaker mounted on an excavator cannot be used.
8. The Contractor shall check RCI top elevations and adjust all installed columns to the planned elevations.
9. Each drill rig must complete the RCI including placement of concrete before beginning drilling of the next RCI.
10. The Contractor shall control and properly dispose of drill flush, and construction related waste, including concrete, in accordance with all applicable local codes and regulations. Provide positive control and discharge of all surface water that will affect construction of the RCI installation. Maintain all pipes or conduits used to control surface water during construction. Repair damage caused by surface water at no additional cost. Upon completion of the work, remove surface water pipes or conduits from the site. Alternatively, with the approval of the Architect/Engineer, pipes and conduit that are left in-place, may be fully grouted and abandoned or left in a way that protects the structure and all adjacent facilities from migration of fines through the pipe or conduit and potential ground loss. Immediately contact the Construction Manager if unanticipated existing subsurface drainage structures are discovered during excavation or drilling. Suspend work in these areas until remedial measures meeting the Architect/Engineer's approval are implemented. Cost of remedial measures or

repair work resulting from encountering unanticipated subsurface drainage structures will be paid for as extra work.

11. During construction, the Contractor shall observe the conditions vicinity of the CSES construction site on a daily basis for signs of ground heave or subsidence. Immediately notify the Construction Manager if signs of movements are observed. Contractor shall immediately suspend or modify drilling or concrete operations if ground heave or subsidence is observed, if the RCI is adversely affected, or if adjacent structures are damaged from the drilling or grouting. If the Architect/Engineer determines that the movements require corrective action, the Contractor shall take corrective action necessary to stop the movement or perform repairs. When due to the Contractor's methods or operations or failure to follow the specified/approved construction sequence, as determined by the Architect/Engineer, the costs of providing corrective actions will be borne by the Contractor. When due to differing site conditions, as determined by the Architect/Engineer, the costs of providing corrective actions will be paid for as extra work.

C. Column Drilling and Excavation

1. Position and align the drill displacement tool at the bored column location.
2. Pre-drilling more than one (1) hole in advance of concrete pour shall not be permitted. Once a column is drilled to the proper depth it shall be immediately filled with concrete.
3. If obstructions, such as boulders, are encountered during excavation for a column, progress through them by means of coring, using a tri-cone roller bit, or appropriate timber cutting bit. Use of drop type Impact hammers and blasting will not be permitted.
4. Refusal of the RCI tool is defined as a reduction in the penetration rate during installation and shall be determined by the Construction Manager. Specific refusal criteria shall depend on the project geology and equipment used and shall be established at the start of the work.
5. Controlling the procedures and operations to preclude undermining, disturbance, or settlement to adjacent structures or utilities. If any disturbance occurs, halt operations and modify the equipment and/or procedures so that no further disturbance occurs. Repair any disturbance to the satisfaction of the Construction Manager and at no additional cost.
6. Waste and spoils shall be disposed of in an appropriate manner. Deposition of waste and spoil on local streets and in sewers will not be permitted.

D. Load Transfer Platform Installation

1. Installation of the LTP shall not commence before a minimum waiting period of seven (7) days after the completion of the RCI.
2. Prior to commencing LTP, the Contractor shall level the ground and remove all debris, roots, protrusions including gravel larger than three (3) inches and sticks/branches larger than ½ inch in diameter. The subgrade shall be proof rolled to provide a uniform and firm surface. If soft areas are observed, as determined by the Construction Manager, shall be excavated and replaced with suitable compacted soil.
3. The reinforced fill material shall be placed in horizontal layers not exceeding 12 inches of uncompacted thickness for heavy compaction equipment. For zones where compaction is accomplished with hand operated equipment, fill shall be placed in horizontal layers not exceeding six (6) inches in uncompacted thickness.
4. Place and compact the reinforced fill material in accordance as specified in this Section. The reinforced fill shall be compacted to a minimum 95 percent of maximum dry density as determined in accordance with ASTM D-1557 (Modified Proctor) at +/- 2 percent of the optimum moisture content.
5. The approved geogrid material shall be placed as shown on the approved Contract Drawings.
6. The use of pegs, pins or manufacturer's recommended method to hold the geosynthetic in place until specified fill material is placed shall be required.
7. Construction equipment shall not be operated directly on the geogrid. Turning of vehicles shall be kept to a minimum to prevent tracks or tires from displacing the fill and/or the geogrid. A minimum fill thickness of 6 inches is required for operation of vehicles over the geogrid.
8. Should the geogrid be torn or punctured, remove the backfill around the damaged area and repair the damaged area in accordance with the manufacturer's guidelines at no cost to the NJDEP.
9. During the installation of the geosynthetic reinforcement the Construction Manager's QCR shall be present.
10. Perform field density testing in accordance with ASTM D1556, ASTM D2167, or ASTM D6938.

11. Evaluate field density test results in relation to maximum dry density as determined by testing material in accordance with ASTM D1557 (Modified Proctor).
12. Location of field density tests shall be mutually acceptable to the testing laboratory and the Architect/Engineer.
13. In the event compacted material does not meet specified in-place density, re-compact material and re-test area until specified results are obtained at no additional cost to the NJDEP.
14. Perform the field density test at the frequency of 1 test per 2500 yd³ or fraction thereof.
15. The LTP shall be constructed to plus or minus ½ inch of the elevations indicated on the construction plans. Provide the Construction Manager with adequate survey information to verify compliance with above tolerances.
16. If the Contractor uses a post-grouting system, all relevant details including grouting pressure, volume, location and mix design, shall be submitted.

3.04 RCI CONCRETE TESTING

- A. During production, samples selected at random of concrete mix shall be taken daily two (2) sets of six (6) cylinders in accordance with ASTM C39. Test one (1) cylinder at seven (7) days and one (1) cylinder at fourteen (14) days for information; test two (2) cylinders at 28 days for acceptance; and hold two (2) reserve cylinders for verification. Strength acceptance will be based on the average of the strengths of the two (2) cylinders tested at 28 days. If one (1) cylinder of a 28-day test manifests evidence of improper sampling, molding, or testing, other than low strength, discard it and use a reserve cylinder for the test result.

An independent testing firm, hired by the Contractor shall collect and test samples of the concrete mix.

- B. The 2-inch cube samples shall be molded, cured in a properly constructed curing box supplied by Contractor, tested in accordance with AASHTO T 106, and shall reach a compressive strength after seven days equal to at least 60 percent of the design strength. The compressive strength shall be the average of the three (3) cubes tested.
- C. If this requirement is not met, Contractor shall modify the proportions of the mix subject to the approval of the Architect/Engineer. If the required design strength is not attained after 28 days, then Contractor shall install replacement column(s) as required. All associated work required due to unacceptable columns shall be at no additional cost to the NJDEP.

- D. The Architect/Engineer may also require Contractor to modify the mix design if an excessive amount of concrete is lost from a column hole into voids in the in-place materials. Materials shall be accurately measured by weight or volume before mixing.
- E. If agitated continuously, the concrete may be held in the mixer or agitator for a period not exceeding three (3) hours at temperatures below 21 degrees Celsius and for a period not exceeding two (2) hours at higher temperatures.

3.05 UNACCEPTABLE RCI'S

- A. Unacceptable RCI's are columns that are rejected by the Construction Manager because of damage, failure to advance through obstructions, mis-location, misalignment, failure to meet load test acceptance criteria, failure to install the column using the approved equipment and procedures, or failure to install the column to the proper depth. Submit a written plan of action to the Architect/Engineer for approval, showing how to correct the problem and prevent its reoccurrence. Repair or augment the column to the satisfaction of the Architect/Engineer to make it acceptable. To mitigate and/or to remedy unaccepted columns, Contractor may be required to provide additional columns or supplement columns to meet specified requirements. All associated work required due to unacceptable columns shall be at no additional cost to the NJDEP.
- B. Allowable Tolerances.
 - 1. Centerline of column shall not be more than 3 inches from indicated plan position.
 - 2. Column alignment shall be within 1 percent of design alignment.
 - 3. Top elevation of column shall be within 2 inches of the design vertical elevation.
 - 4. Centerline of core reinforcement shall not be more than 0.6 inches from centerline of column.

3.06 RCI STATIC LOAD TESTS

- A. Perform static load tests on sacrificial piles as approved by the Architect/Engineer, in accordance with ASTM D1143.
- B. The Contractor shall furnish all testing materials and equipment as required, install test and reaction piles, if necessary, and perform the load tests only in the presence of the Architect/Engineers representative.
- C. The RCI test locations shall be within the horizontal limits of the CSES planned area and consist of a minimum of five (5) sacrificial pile locations.

1. Static Load Tests.
 - a. The RCI static load test shall be performed using the standard loading procedures in ASTM D 1143 Quick Load (QL) test.
 - b. After completion of the test, reload the test sacrificial RCI to failure, or 3 times the design load, whichever occurs first.
 - c. The design load in kips, shall be in accordance with approved shop drawings and calculations submitted by the Contractor and prepared by a licensed Professional Engineer of the State of New Jersey.
 - d. The load test RCI is sacrificial and not to be used to support the CSES.
 - e. The Contractor shall submit for review and acceptance the RCI load-testing program. The testing program submittal shall be provided two (2) weeks prior to starting the load testing. This RCI verification load testing proposal shall indicate the minimum following information:
 - i. Type and accuracy of apparatus for measuring load,
 - ii. Type and accuracy of apparatus for applying load,
 - iii. Type and accuracy of apparatus for measuring the column deformation,
 - iv. Type and capacity of reaction load system, and
 - v. Hydraulic jack calibration report.
 - f. During static load testing, backup monitoring shall be performed using piano wire, mirror, and scale at the pile butt, where practical. Survey monitoring shall be included.
 - g. The Contractor's engineer will give the Architect/Engineer written confirmation concerning RCI construction and the results of the load test within three (3) working days after the completion of the verification load tests. This written confirmation will either confirm the column capacities as shown in the shop drawings or reject the columns based upon the results of the verification tests.
 - h. When a column fails, the Contractor shall modify the design, the construction procedure, or both. Any modification which requires changes to the structure shall have prior review and evaluation and acceptance of

the Architect/Engineer. Any modifications of design or construction procedures shall be at the Contractor's expense.

D. RCI Column Integrity Test

1. The RCI column integrity test shall be performed by an independent testing firm, hired by the Contractor.
2. The testing shall be performed on a minimum of 2 percent of the production columns and the sacrificial load test columns.
3. The column integrity test shall be performed using thermal integrity profiling in accordance with ASTM D 7949.
4. All equipment necessary to perform the column integrity testing shall be furnished by the Contractor.

E. CSES Monitoring Program

1. The Contractor shall install at a minimum the monitoring instruments at locations provided on the Contract Drawings to measure the movement of the embankment constructed on the CSES. The monitoring program shall be in accordance with Section 310930.
2. The Contractor shall not install any instruments until the monitoring program has been approved by the Architect/Engineer.
3. At a minimum the monitor program shall include:
 - a. List of instruments to be installed
 - b. Monitoring frequency and reporting
 - c. Pre-installation acceptance testing
 - d. List of Calibration equipment required, and recommended frequency of calibration.

3.07 CLEANING UP

- A. After the completion of the CSES installation work, the Contractor shall cleanup work area in accordance with Section 017423.

3.08 CONTRACT CLOSEOUT

- A. Provide in accordance with Section 017700.

END OF SECTION 316623

NO TEXT ON THIS PAGE

SECTION 321200 - FLEXIBLE PAVING

PART 1 - GENERAL

1.01 DESCRIPTION

A. Provide flexible paving as indicated and in compliance with Contract Documents.

1. Scope includes:

- a. Aggregate base course.
- b. Asphalt concrete pavement.

1.02 PAYMENT

A. No separate payment shall be made for performing any work required under this Section. All costs for work required by this Section shall be included in the applicable lump sum as set forth in Section 012901.

1.03 REFERENCES

A. American Association of State Highway and Transportation Officials (AASHTO):

1. M147: Standard Specification for Materials for Aggregate and Soil-Aggregate Subbase, Base, and Surface Courses.
2. T89: Standard Method of Test for Determining the Liquid Limit of Soils.
3. T90: Standard Method of Test for Determining the Plastic Limit and Plasticity Index of Soils.
4. T99: Standard Method of Test for Moisture-Density Relations of Soils Using a 2.5-kg (5.5-lb) Rammer and a 305-mm (12-in.) Drop.
5. T104: Soundness of Aggregate by Use of Sodium Sulfate or Magnesium Sulfate.

B. State Department of Transportation (DOT):

1. NJDOT Specifications: New Jersey Department of Transportation Standard Specifications for Road and Bridge Construction, current edition.

1.04 RELATED SECTIONS

- A. General Conditions Article 4.7 – Shop Drawings and Other Submittals
- B. Section 012901 – Measurement and Payment

- C. Section 014300 - Quality Requirements
- D. Section 016100 - Control of Materials
- E. Section 017700 - Contract Closeout
- F. Section 312300 - Excavation and Fill

1.05 DEFINITIONS

- A. Gravel: Coarse aggregate resulting from natural disintegration and abrasion of rock or processing of weakly bound conglomerate.
- B. Crushed Gravel: The product resulting from the artificial crushing of gravel with substantially all fragments having at least one face resulting from fracture.
- C. Crushed Stone: The product resulting from the artificial crushing of rocks, boulders, or large cobblestones, substantially all faces of which have resulted from the crushing operation.
- D. Hot Mix Asphalt (HMA) Mix Designations. HMA mix designations follow the identification method described in NJDOT Standard Specifications Section 902.02. Various HMA mixtures are required for this Project and are detailed on the Plans. The requirements for specific HMA mixtures are identified by the abbreviated fields in the Item description as defined as follows:

HOT MIX ASPHALT 12.5H64 SURFACE COURSE

1. “HOT MIX ASPHALT” “Hot Mix Asphalt” or HMA is located in the first field in the Item description for the purpose of identifying the mixture requirements.
2. “12.5” The second field in the Item description designates the nominal maximum size aggregate (in millimeters) for the job mix formula (sizes are 4.75, 9.5, 12.5, 19, 25, and 37.5 mm).
3. “M” The third field in the Item description designates the design compaction level for the job mix formula based on traffic forecasts as listed in NJDOT Standard Specifications Table 902.02.03-2 (levels are L=low and M=medium).
4. “64” The fourth field in the Item description designates the high temperature (in C°) of the performance-graded binder (options are 64, 70, and 76 degrees C). All binders shall have a low temperature of -22 degrees C, unless otherwise specified. Other options are “64” for PG 64-22 and “E” for PG 64E-22, as specified in NJDOT Specification Section 902.01.01.
5. “SURFACE COURSE” The last field in the Item description designates the intended use and location within the pavement structure (options are surface, intermediate, or base course).

1.06 SUBMITTALS

- A. Submit the following shop drawings in accordance with General Conditions Article 4.7.
 - 1. Sustainable design submittals.
 - 2. Hot Mix Asphalt (HMA) mix design.
 - 3. Asphalt weigh tickets per truckload, signed and sealed by a certified weighmaster.
 - 4. Resin-bound aggregate mix sample.
- B. Test Results:
 - 1. Core samples.
 - 2. Testing results.
- C. Paving Plan, as per NJDOT Specifications, Section 401.03.07.A.

1.07 QUALITY ASSURANCE

- A. Comply with the requirements specified in Section 014300.
- B. Codes and Standards: Comply with the latest edition of NJDOT standard specifications and with local governing regulations.

1.08 DELIVERY STORAGE AND HANDLING

- A. Comply with the requirements specified in Section 016100.
- B. Transport bituminous mixtures in covered trucks,
 - 1. Suspend deliveries if;
 - a. It is raining or rain is imminent, or
 - b. Air temperature is less than 60 degrees F.
- C. Adjust weight, type, capacity, haul routes, and method of operation of hauling vehicles so that:
 - 1. No damage results to existing streets, subgrade or base course, and
 - 2. Noise and air pollution levels are not noticeably increased along selected haul route.
- D. Haul routes through residential areas shall be avoided.

- E. Submit haul route, procedures for transport, and schedule of operation times to Construction Manager for acceptance.

1.09 PROJECT CONDITIONS

- A. Weather Limitations: Apply prime and tack coats when ambient temperature is above 50 degrees F, and when temperature has not been below 35 degrees F for 12 hours immediately prior to application. Do not apply when base is wet or contains an excess of moisture.
- B. Place asphalt concrete surface course when atmospheric temperature is above 40 degrees F, and when base is dry. Place binder course when air temperature is above 30 degrees F and rising.

PART 2 - PRODUCTS

2.01 AGGREGATE MATERIALS

- A. According to AASHTO M147, unless noted otherwise.
- B. Aggregate, including blended filler, shall have:
 - 1. Liquid limit (LL) of not more than 25 as determined by AASHTO T89.
 - 2. Plasticity index (PI) of not more than 6 as determined by AASHTO T90.
- C. At least 45 percent, by count, of number of particles of aggregate retained on No. 4 sieve shall have at least one (1) fractured face.
- D. Remove oversized material by screening or crushing to required sizes.
- E. Soundness: AASHTO T104, 5 cycles: No greater than 18 percent weight loss.
- F. Filler for Blending:
 - 1. Use filler for meeting gradation requirements or for satisfactory binding of material. Uniformly blend with base course material at screening plant.
 - 2. Obtain material from sources accepted by Construction Manager.
 - 3. Material shall be free of agglomerations or lumps and contain no more than 15 percent of material retained on No. 4 sieve.

2.02 AGGREGATE BASE COURSE

- A. Dense-Graded Aggregate: NJDOT Specifications, Section 901.10. The Qualified Products List (QPL) can be found at <https://www.state.nj.us/transportation/eng/materials/qualified/QPLDB.shtm>.

2.03 PAVEMENT MATERIALS

- A. HMA: 9.5M64.
- B. Coarse Aggregate: NJDOT Specifications, Section 901.03.
- C. Aggregates for Hot Mix Asphalt: NJDOT Specifications, Section 901.05.
- D. Asphaltic Materials:
 - 1. Prime Coat: NJDOT Specifications, Section 902.01.02.
 - 2. Tack Coat: NJDOT Specifications, Section 902.01.01.
 - 3. Asphalt Binder: NJDOT Specifications, Section 902.01.01.

PART 3 - EXECUTION

3.01 EXAMINATION

- A. Check subgrade as to soundness, outline, and contour.

3.02 SUBGRADE PREPARATION

- A. Scrape down subgrade bumps and irregularities to obtain smooth, even surface.
- B. Proof roll as specified in Section 312300.
- C. Remove and replace soft or spongy areas as specified in Section 312300.

3.03 PAVEMENT PREPARATION

- A. Remove loose material from compacted base course immediately before applying herbicide treatment or prime coat.
- B. If base course becomes rutted, loose, or uneven due delays in placing subsequent courses then proof roll prepared surface to check for unstable areas. Provide additional compaction or remove unstable areas, backfill and compact. Do not begin paving work until deficient areas have been re-graded and corrected and are ready to receive paving.

- C. Herbicide Treatment: Apply chemical weed control agent in compliance with manufacturer's recommended dosage and application instructions.
- D. Prime Coat: Apply prime coat in accordance with NJDOT Specifications, Section 401.03.02.
- E. Tack Coat: Apply tack coat in accordance with NJDOT Specifications, Section 401.03.02.

3.04 BASE COURSE INSTALLATION

- A. Construct subbase in accordance with NJDOT Specifications, Section 301.
- B. Construct aggregate base course in accordance with NJDOT Specifications, Section 302.

3.05 PLACING MIX

- A. Place asphalt pavement in accordance with NJDOT Specifications, Section 401.

3.06 ROLLING

- A. General: Begin rolling when mixture will bear roller weight without excessive displacement. Compact mixture with hot hand tampers or vibrating plate compactors in areas inaccessible to rollers. Compact in accordance with NJDOT Specifications, Section 401.03.03.F.
- B. Breakdown Rolling: Accomplish breakdown or initial rolling immediately following rolling of joints and outside edge. Check surface after breakdown rolling, and repair displaced areas by loosening and filling, if required, with hot material.
- C. Second Rolling: Follow breakdown rolling as soon as possible, while mixture is hot. Continue second rolling until mixture has been thoroughly compacted.
- D. Finish Rolling: Perform finish rolling while mixture is still warm enough for removal of roller marks. Continue rolling until roller marks are eliminated and course has attained maximum density.
- E. Patching: Remove and replace paving areas mixed with foreign materials and defective areas. Cut-out such areas and fill with fresh, hot asphalt concrete. Compact by rolling to maximum surface density and smoothness.

3.07 FIELD QUALITY CONTROL

- A. Base Course Testing:

1. Optimum Moisture Content and Maximum Density: Comply with AASHTO T99, Method C, with replacement of fraction of aggregate retained on 3/4-inch sieve. Replace with No. 4 to 3/4-inch material.

B. Pavement Testing:

1. General: Test in-place asphalt concrete courses for compliance with requirements for thickness and surface smoothness. Repair or remove and replace unacceptable paving.
2. Thickness Tolerances: Acceptable in-place compacted thickness tolerance is:
 - a. Base Course Thickness: 1/4-inch, plus or minus.
 - b. Surface Course Thickness: 1/4-inch, plus or minus.
3. Surface Smoothness Tolerances: Test finished surface of each asphalt concrete course for smoothness, using 10-foot straightedge applied parallel with, and at right angles to centerline of paved area. Acceptable tolerance is:
 - a. Binder Course: 1/4-inch.
 - b. Surface Course: 1/8-inch.
 - c. Crowned Surfaces: Test with crowned template centered and at right angle to crown. Maximum allowable variance from template, 1/4 inches.
 - d. Profile and Section: Variation from true shall not exceed +/- 3/8-inch.

3.08 PROTECTION

A. After final rolling:

1. Do not permit vehicular traffic on pavement until it has cooled and hardened, and the surface temperature is less than 140 degrees F.
2. Protect paving from traffic until mixture has cooled enough not to become marked.

3.09 CONTRACT CLOSEOUT

- A. Provide in accordance with Section 017700.

END OF SECTION 321200

NO TEXT ON THIS PAGE

SECTION 321223 - IMPRINTED ASPHALT

PART 1 - GENERAL

1.01 DESCRIPTION

- A. Section includes embossing patterns in new asphalt pavement.

1.02 PAYMENT

- A. No separate payment shall be made for performing any Work required under this Section. All costs for Work required by this Section shall be included in the applicable lump sum, unit price(s), or allowance(s) as set forth in Section 012901.

1.03 RELATED SECTIONS

- A. General Conditions Article 4.7 – Shop Drawings and Other Submittals
- B. Section 012910 – Measurement and Payment
- C. Section 014300 - Quality Requirements
- D. Section 016100 - Control of Materials
- E. Requirements from the following section also apply to this Section
 - 1. Section 321200 - Flexible Paving

1.04 PREINSTALLATION MEETINGS

- A. Preinstallation Conference: Before any work, conduct conference at Project site.

1.05 SUBMITTALS

- A. Submit the following items in accordance with General Conditions Article 4.7.
- B. Product Data: For each type of product.
- C. Shop Drawings:
 - 1. Indicate imprinted patterns, colors, and dimensions. Proposed work to match local standards.
- D. Samples for Initial Selection: For each type of product requiring color selection.

- E. Samples for Verification: For each pattern and color with precut marking material, in manufacturer's standard sizes.
- F. Qualification Data: Installer shall be familiar and comply with Section 014300.

1.06 QUALITY ASSURANCE

- A. Refer to Section 014300.
- B. Installer Qualifications: Imprinted-asphalt manufacturer's authorized Installer who is trained and approved for installation of imprinted asphalt required for this Project.
- C. Regulatory Requirements: Comply with materials, workmanship, and other applicable requirements of the standard details and specifications of the City of Hoboken for imprinted asphalt work.
 - 1. Measurement and payment provisions and safety program submittals included in standard specifications do not apply to this Section.

1.07 FIELD CONDITIONS

- A. Environmental Limitations: Proceed with coating imprinted pavement only when air temperature is at least 50 deg F and rising and will not drop below 50 deg F within eight hours of coating application. Proceed only if no precipitation is expected within two hours after applying the final layer of coating.

PART 2 - PRODUCTS

2.01 MANUFACTURERS

- A. The Contractor shall supply the Architect/Engineer with the list of manufacturers and products for approval 30 days prior to beginning work. For definitions of terms and requirements for Contractor's product selection, see Section 016100.

2.02 MATERIALS

- A. Templates: Imprinted-asphalt manufacturer's standard flexible templates for imprinting pattern into hot asphalt paving.
 - 1. Pattern: Custom pattern to match existing imprinted asphalt located in the City of Hoboken.
- B. Coating System: Imprinted-asphalt manufacturer's standard system formulated for exterior application on asphalt paving surfaces.

1. Base Coating: Portland cement and epoxy-modified acrylic polymer blended with sand and aggregate, formulated for exterior application on asphalt paving surfaces.
 2. Top Coating: Epoxy-modified acrylic polymer blended with sand and aggregate, formulated for exterior application on asphalt paving surfaces.
 3. Colorant: UV-stable pigment blend, added to each coating layer.
 4. Color: To match existing imprinted asphalt located in the City of Hoboken.
- C. Precut Marking Material: Imprinted-asphalt manufacturer's standard, reflectorized, thermoplastic, 90-mil minimum thickness, formulated for exterior application in imprinted, asphalt paving surfaces, and matching the imprinted pattern of templates.

PART 3 - EXECUTION

3.01 EXAMINATION

- A. Verify that pavement is dry and in suitable condition to begin imprinting process according to manufacturer's written instructions.
- B. Proceed with asphalt imprinting only after unsatisfactory conditions have been corrected.
- C. Verify that utilities, traffic loop detectors, and other items requiring a cut and installation beneath the asphalt surface or repairs to the asphalt surface have been completed and that asphalt surface is flush with adjacent asphalt prior to beginning installation of imprinted asphalt.

3.02 IMPRINTING ASPHALT

- A. General: Imprint asphalt according to manufacturer's written instructions, using manufacturer's recommended equipment.
- B. Freshly Laid Asphalt: Immediately after asphalt has been laid and compacted but still plastic, begin the surface-imprinting process.
 1. Monitor asphalt surface temperature to comply with imprinted-asphalt manufacturer's written recommendations to ensure required temperature to perform surface imprinting.
 2. Reheat asphalt if surface temperature drops below that required.
- C. Reheating Asphalt: Soften asphalt pavement surface by heating to a depth of at least 1/2 inch without burning asphalt.

1. Heat to a temperature of 300 to 325 deg F immediately before applying templates.
 2. Regularly monitor the pavement temperature to prevent overheating.
 3. Direct flame heaters are not permitted.
 4. If pavement is overheated and begins to emit black smoke, remove damaged pavement by milling down 1 inch and replace removed pavement with new, compacted surface course prior to resuming imprinting work.
- D. Imprinting the Surface: Apply and imprint templates to a minimum depth as required to embed precut marking material flush or barely beneath pavement surface.
- E. Applying Coating: After imprinted surface has cooled, apply two layers of base coating followed by two layers of top coating, or as required by the City of Hoboken. Do not allow traffic until coating has completely dried and cured.
- F. Applying Precut Marking Material: Position precut marking material aligned with imprinted pattern and slowly heat to a temperature no higher than 325 deg F until marking material begins to liquefy and flow. Do not allow traffic until installed marking material has cooled to ambient temperature.
- G. Repairs: Perform repairs to defective locations according to imprinted-asphalt manufacturer's written instructions.
- 3.03 CONTRACT CLOSEOUT
- A. Provide in accordance with Section 017700.

END OF SECTION 321223

SECTION 321300 - RIGID PAVING

PART 1 - GENERAL

1.01 DESCRIPTION

A. Section includes:

1. Provide rigid paving as indicated and in compliance with Contract Documents.

1.02 PAYMENT

- A. All costs for Work required by this Section shall be included in the applicable unit price(s), as set forth in Section 012901.

1.03 REFERENCES

A. American Concrete Institute (ACI):

1. 305R: Guide to Hot Weather Concreting.
2. 306R: Guide to Cold Weather Concreting.

B. American Association of State Highway and Transportation Officials (AASHTO):

1. T26: Standard Method of Test for Quality of Water to Be Used in Concrete.

C. ASTM International (ASTM):

1. C33/C33M: Standard Specification for Concrete Aggregates.
2. C138/C138M REV A: Standard Test Method for Density (Unit Weight), Yield, and Air Content (Gravimetric) of Concrete.
3. C150/C150M: Standard Specification for Portland Cement.
4. C173/C173M: Standard Test Method for Air Content of Freshly Mixed Concrete by the Volumetric Method.
5. C231/C231M REV A: Standard Test Method for Air Content of Freshly Mixed Concrete by the Pressure Method.
6. C260/C260M REV A: Standard Specification for Air-Entraining Admixtures for Concrete.

7. C309: Standard Specification for Liquid Membrane-Forming Compounds for Curing Concrete.
 8. C494/C494M: Standard Specification for Chemical Admixtures for Concrete.
 9. C1315: Standard Specification for Liquid Membrane-Forming Compounds Having Special Properties for Curing and Sealing Concrete.
 10. C1602/C1602M: Standard Specification for Mixing Water Used in the Production of Hydraulic Cement Concrete.
 11. D1751: Standard Specification for Preformed Expansion Joint Filler for Concrete Paving and Structural Construction (Nonextruding and Resilient Bituminous Types).
 12. D6690: Standard Specification for Joint and Crack Sealants, Hot Applied, for Concrete and Asphalt Pavements.
- D. NJDOT Specifications: New Jersey Department of Transportation (NJDOT) Standard Specifications for Road and Bridge Construction, current edition.

1.04 RELATED SECTIONS

- A. General Conditions Article 4.7 – Shop Drawings and Other Submittals.
- B. Section 012901 – Measurement and Payment.
- C. Section 014300 - Quality Requirements.
- D. Section 016100 - Control of Materials.
- E. Section 017700 - Contract Closeout.
- F. Section 031000 - Concrete Formwork.
- G. Section 033000 - Cast-in-Place Concrete.
- H. Section 033500 - Concrete Finishes and Floor Treatment.
- I. Section 312300 - Excavation and Fill.
- J. Section 321600 – Concrete Curbs, Gutters, and Sidewalks.
- K. Section 340113 – Operation and Maintenance of Roadways.

1.05 DEFINITIONS

- A. Cold Weather: Refer to ACI 306R. A period when for more than three successive days the average daily outdoor temperature drops below 40 degrees F. The average daily temperature is the average of the highest and lowest temperature during the period from midnight to midnight. When temperatures above 50 degrees F occur during more than half of any 24-hour duration, the period shall no longer be regarded as cold weather.
- B. Hot Weather: Refer to ACI 305R. Any combination of the following conditions that tend to impair the quality of freshly mixed or hardened concrete by accelerating the rate of moisture loss and rate of cement hydration, or otherwise resulting in detrimental results.
 - 1. High ambient temperature.
 - 2. High concrete temperature.
 - 3. Low relative humidity.
 - 4. Wind velocity.
 - 5. Solar radiation.

1.06 SUBMITTALS

- A. Submit the following in accordance with General Conditions Article 4.7.
 - 1. Concrete: Aggregate, cement, and admixtures product data.
 - 2. Concrete mix design with laboratory test results.
 - 3. Joint material product data.
 - 4. Compound product data.
 - 5. Concrete Test Results.
- B. Concreting Plan, as per NJDOT Specifications, Section 405.03.02.A.

1.07 QUALITY ASSURANCE

- A. Comply with the requirements specified in Section 014300.
- B. Sustainability Standards Certifications.

- C. Work shall conform to all requirements of ACI 330.1 published by the American Concrete Institute, Farmington Hills, Michigan, except as modified by these contract documents.
- D. Codes and Standards: Comply with the latest edition of NJDOT standard specifications and with local governing regulations.

1.08 DELIVERY STORAGE AND HANDLING

- A. Comply with the requirements specified in Section 016100.
- B. Adjust weight, type, capacity, haul routes, and method of operation of hauling vehicles so that:
 - 1. No damage results to existing streets, subgrade or base course, and
 - 2. Noise and air pollution levels are not noticeably increased along selected haul route.

PART 2 - PRODUCTS

2.1 MATERIALS

- A. Aggregate Base: Minimum 4 inches thick, unless noted otherwise.
 - 1. Dense-Graded Aggregate: NJDOT Specifications, Section 901.10. The Qualified Products List (QPL) can be found at <https://www.state.nj.us/transportation/eng/materials/qualified/QPLDB.shtm..>

2.2 CONCRETE FORMWORK

- A. Forms: Refer to Section 031000.
 - 1. Forms shall be made of steel or wood or other material capable of supporting concrete and mechanical concrete placing equipment that is sufficiently rigid to maintain the specified tolerances.
 - 2. Forms shall be clean and free of dirt, rust, and hardened concrete.

2.3 CONCRETE

- A. Concrete: NJDOT Specifications, Section 903.03. Use Table 903.03.06-1, Requirements for Roadway Concrete Items.
- B. Water: Clean and not detrimental to concrete, within the limits of AASHTO T26.
- C. Thickness: As indicated.

2.4 CONCRETE REINFORCEMENT

- A. Reinforcing Steel: NJDOT Specifications, Section 905.

2.5 CONCRETE FINISHES

- A. See Section 033500 for additional requirements.
- B. Float and normal broom finish.

2.6 JOINTS

- A. Joint Materials. NJDOT Specifications, Section 914.

2.7 ACCESSORIES

- A. Curing Compound: NJDOT Specifications, Section 903.10.
- B. Anti-Spall Compound:

- 1. Manufacturers:

- a. Iso-Flex 650 by LymTal International, Inc.
- b. Sika AG
- c. PolyCoat Division of American Polymers Corp
- d. Or approved equal

- 2. Compound shall be composed of 50 percent boiled linseed oil and 50 percent commercial grade kerosene or mineral spirits, by volume. Commercially prepared linseed oil mixtures are acceptable provided they are non-emulsified mixtures which are specifically for protection from deicing chemicals.

2.8 COLORANT

- A. Davis Colors Hydrotint, Alabama Pigments Precision-Pac, Scofield CHROMIX or approved equal. Color per Contract Drawings.

PART 3 - EXECUTION

3.01 EXAMINATION

- A. Do not place pavement on frozen subgrade.

- B. Check subgrade as to soundness, outline, and contour.

3.02 PREPARATION

- A. Excavate and shape subgrade to line, grade, and cross section.
- B. Remove all soft subgrade material encountered while compacting and backfill with aggregate base.
- C. Repeat fine grading and compaction of subgrade areas which have been subjected to vehicular construction traffic and equipment.
- D. Moisten aggregate base immediately before placing concrete to minimize absorption of water from fresh concrete.
- E. Provide concrete surfaces that are clean and dry - free of oil, dirt or foreign materials immediately before application of compounds or painting.

3.03 COMPACTION

- A. Refer to Section 312300 for additional compaction requirements.
- B. Moisture: Maintain moisture content that is 3 percent of optimum moisture to attain required compaction density.
- C. Subgrade: Compact as specified in this Section.
- D. Aggregate Base: Compact as specified in this Section.

3.04 FORMWORK

- A. Set, align, and brace forms so that the pavement will meet the tolerances specified.
- B. Apply form release agent to inside face of forms before placing concrete.
- C. The edge of previously placed concrete may be used as a form. Do not apply form release agent to previously placed concrete, unless prevention of bond between the new and the old concrete is desired.

3.05 PLACING CONCRETE

- A. Place concrete on uniform subgrade.
- B. Consolidate and strike off to proper elevation.
- C. Place concrete continuously to prevent formation of “cold joints”.

- D. Where placing operations stop, install bulkhead to form straight joint.
- E. Texture pavement surface with broom.
- F. Follow recommendations in ACI 305R when concreting during hot weather.
- G. Follow recommendations in ACI 306R when concreting during cold weather.

3.06 JOINTS

- A. Joint pavement as indicated.
- B. Joint Spacing: Maximum allowable is 30 times the pavement thickness.
- C. Make contraction joints by sawing, tooling or installing insert with no exceptions noted to depth of 1-1/4 inches.
- D. Cut saw joints as soon as possible without raveling concrete edges.
- E. Install full depth expansion joints using 1/2-inch-thick joint material around castings and where pavement abuts structures.

3.07 REPAIR/RESTORATION

- A. Repair damaged work by replacing with new pavement to the nearest construction isolation joint.

3.08 FINISHING

- A. Float: Use magnesium or aluminum hand floats or power floats with slip on float shoes after concrete has stiffened to point where 1/4-inch maximum indentation can be imparted by normal foot pressure. Do not use combination blades for floating.
- B. Float finish shall result in uniform smooth granular texture.
- C. After floating, check slab tolerances with 10-foot straightedge. Fill low spots with fresh concrete.
- D. Do not sprinkle with dry cement or add water.
- E. Broom Finish:
 - 1. Normal Broom Finish: Use fine, soft bristled broom to produce a non-skid surface.
 - 2. Texture parallel to travel direction of pavement.
 - 3. Texture shall be reviewed by the Construction Manager.

3.09 TOLERANCES

- A. Construct pavement to comply with the following tolerances:
 - 1. Elevation: 1/2-inch.
 - 2. Thickness: +3/8 inch, -1/4-inch.
 - 3. Surface: In any direction, the gap below a 10-foot unlevelled straightedge resting on high spots shall not exceed 1/2-inch.
- B. Joint reinforcement: Tie bars, alignment of tie bar end relative to line perpendicular to edge of pavement: 1/2-inch per foot of tie bars.
- C. Dowels:
 - 1. Lateral alignment and spacing: 1 inch.
 - 2. Vertical alignment: 1/4-inch.
 - 3. Alignment of dowel bar end relative to line perpendicular to edge of pavement: 1/4-inch per foot of dowel.
- D. Joint spacing:
 - 1. Contraction joint depth (slab thickness): +1/4-inch, -0 inch.
 - 2. Joint width: +1/8-inch, -0 inch.

3.10 FIELD QUALITY CONTROL

- A. Refer to Section 312300 for compaction and testing requirements.
- B. Submit compaction test results to the Construction Manager for review.
- C. Concrete Testing: Section 033000. Maintain records of placed concrete including: record date, location of pour, quantity, air temperature, and test samples taken. Submit test results to the Construction Manager for review.
- D. Defective Concrete: As defined in Section 033000.

3.11 PAINTING AND STRIPING

- A. Refer to Section 340113 for additional requirements.
- B. Paint pavement markings and striping after concrete has cured for at least 28 days.

- C. Protect markings from traffic until completely dry to prevent tracking.

3.12 PROTECTION

- A. Protect concrete from damage and replace if damage occurs.
- B. Protect pavement from traffic for a minimum of three (3) weeks of ambient temperatures above 40 degrees F.
- C. Do not open the pavement to vehicular traffic until the in-place compressive strength is at least 3000 psi or until the pavement is accepted by the Construction Manager for opening to traffic.
- D. Anti-Spall Compound:
 - 1. Apply compound no sooner than 28 days after placement of concrete.
 - 2. Spray two coats, allowing for first coat to completely dry.
 - 3. Minimum spray rates shall be: 40 square yards per gallon (first application) and 60 square yards per gallon (second application).

3.13 CONTRACT CLOSEOUT

- A. Provide in accordance with Section 017700.

END OF SECTION 321300

NO THIS ON THIS PAGE

SECTION 321343 – PERVIOUS CONCRETE PAVING

PART 1 - GENERAL

1.01 SUMMARY

- A. The Section specifies the requirements for pervious concrete pavements and geotextile fabric.

1.02 PAYMENT

- A. No separate payment shall be made for performing any Work required under this Section. All costs for Work required by this Section shall be included in the applicable lump sum, unit price(s), or allowance(s) as set forth in Section 012901.

1.03 REFERENCES

- A. The publications listed below form a part of this specification to the extent referenced. The publications are referred to in the text by the basic designation only.
- B. American Concrete Institute (ACI):
 - 1. ACI 211.1: (1991) Selecting Proportions for Normal, Heavyweight, and Mass Concrete
 - 2. ACI 305R: (1991) Hot Weather Concreting
 - 3. ACI 306.1: (1990) Cold Weather Concreting
 - 4. ACI 117: (2007) Tolerances for Concrete Construction and Materials, Section 12
 - 5. ACI 301: (2020) Specifications for Structural Concrete
 - 6. ACI 522.1: (2020) Specification of Construction of Pervious Concrete Pavement
- C. American Society for Testing and Materials (ASTM):
 - 1. ASTM C 31: (1991) Making and Curing Concrete Test Specimens in the Field
 - 2. ASTM C 33: (1993) Concrete Aggregates
 - 3. ASTM C 78: (1994) Flexural Strength of Concrete (Using Simple Beam with Third-Point Loading)
 - 4. ASTM C 94: (1994) Ready-Mixed Concrete
 - 5. ASTM C 143: (1990; Rev. A) Slump of Hydraulic Cement Concrete

6. ASTM C 150: (1995) Portland Cement
7. ASTM C 171: (1995) Sheet Materials for Curing Concrete
8. ASTM C 172: (1990) Sampling Freshly Mixed Concrete
9. ASTM C 494: (1992) Chemical Admixtures for Concrete
10. ASTM C 618: (1995) Coal Fly Ash and Raw or Calcined Natural Pozzolan for use as a Mineral Admixture in Portland Cement Concrete.
11. ASTM C 989: (1994; Rev. A) Ground Granulated Blast-Furnace Slag for Use in Concrete and Mortars
12. ASTM C1602: Standard Specification for Mixing Water Used in the Production of Hydraulic Cement Concrete
13. ASTM C1701: Standard for Infiltration Rate of In-Place Pervious Concrete
14. ASTM D 98: (1995) Calcium Chloride
15. ASTM D 4355: (2014) Standard Test Method for Deterioration of Geotextiles
16. ASTM D 4491: (2014) Standard Test Method for Water Permeability of Geotextiles by Permittivity
17. ASTM D 4632 (2015) Standard Test Method for Grab Breaking Load and Elongation of Geotextiles
18. ASTM D 4751: (2012) Standard Test Method for Determining Apparent Opening Size of Geotextiles
19. ASTM C 1107: (2014) Standard Specification for Packaged Dry, Hydraulic-Cement Grout (Nonshrink)
20. ASTM C 1688: (2014) Standard Test Method for Density and Void Content of Freshly Mixed Pervious Concrete

1.04 RELATED SECTIONS

- A. General Conditions Article 4.7 – Shop Drawings and Other Submittals
- B. Section 012901 – Measurement and Payment
- C. Section 014300 – Quality Requirements
- D. Section 016100 – Control of Materials

- E. Section 017700 – Contract Closeout
- F. Section 031000 – Concrete Formwork
- G. Section 033000 – Cast-in-place Concrete
- H. Section 033500 – Concrete Finishes and Floor Treatment
- I. Section 312300 – Excavation and Fill

1.05 SUBMITTALS

- A. Submit the following in accordance with General Conditions Article 4.7.
 - 1. Manufacturer’s catalog data for curing materials, and admixtures.
 - 2. Concrete mix design: Thirty days minimum prior to concrete placement, submit mix design for each strength and type of concrete.
 - 3. Laboratory test reports for concrete materials and mix design tests including compressive strength tests, density and void content.
 - 4. Material Certificates stating that each material item complies with or exceeds specified requirements. Provide certification from admixture manufacturers that chloride content complies with specified requirements.
 - 5. Shop Drawings:
 - a. Placing Drawings: Submit placing drawings for concrete pavement showing fabrication dimensions.
 - b. Concrete Joint layout drawing including dimensions, locations and joint type.
 - 6. Samples:
 - a. Obtain color selection from the Landscape Architect and submit a minimum of three 12 x 12-inch samples of proposed integral color concrete paving. Include representative finish.
 - b. Submit a minimum of two more additional samples sets with color and finish adjustments as directed by the Landscape Architect, until approval is obtained. Approved sample shall serve as the basis for the site mock-up.
 - 7. Records:
 - a. Retain records of concrete poured, including exact mix proportions, slumps, placement, and the source of the concrete.

- b. Submit copy to Owner's Construction Manager.

1.06 QUALITY ASSURANCE

- A. Comply with the requirements specified in Section 014300.

1.07 DELIVERY, STORAGE, AND HANDLING

- A. Comply with the requirements specified in Section 016100.

PART 2 - PRODUCTS

2.01 MATERIALS

- A. Cement: Portland cement Type I or II conforming to ASTM C150
- B. Water: Potable and comply with ASTM 1602.
- C. Coarse Aggregates: 3/8-inch coarse aggregate which meets 3/8-inch to No. 16 per ASTM C 33, or meeting 3/8-inch to No. 50 per ASTM D 448.
- D. Coarse Aggregate for Fine Grain Pervious Concrete Pavement: No. 9 per ASTM D 448.
- E. Fine Aggregate: ASTM C33 sand.
- F. Admixtures: Where not shown or specified, the use of admixtures is subject to written approval of the Landscape Architect. Provide admixtures that contain no more than 0.1 percent chloride ions.
 - 1. Fly Ash: Conform to ASTM C 618.
 - 2. Water Reducer: Type A per ASTM C494
 - 3. Retarder: Type B per ASTM C494
 - 4. Water Reducer/Retarder: Type D per ASTM C494
 - 5. Air entrainment: Per ASTM C 260
 - 6. Ground Granulated Blast Furnace Slag: ASTM C 989
- G. Forms: Section 031000.
 - 1. Forms shall be made of steel or wood or other material capable of supporting concrete and mechanical concrete placing equipment that is sufficiently rigid to maintain the specified tolerances.
 - 2. Forms shall be clean and free of dirt, rust, and hardened concrete.

H. Curing Materials:

1. Polyethylene Sheeting: ASTM C 171, 6 mil.

I. Joints Fillers: NJDOT Specifications, Section 914.

A. Colorant: Davis Colors Hydrotint, Alabama Pigments Precision-Pac, Scofield CHROMIX or approved equal. Color per Contract Drawings.

J. Choker Course: Section 312300.

K. Permeable Aggregate Base: Section 312300.

L. Storage Gravel: Section 312300.

2.02 MIX DESIGN

A. Design mix in accordance with ACI 211.1. Concrete shall conform to the following:

1. Concrete for pavements:

- a. Maximum aggregate size: 3/8-inch.
- b. Volume of aggregate: 27 cubic feet per cubic yard when calculated as a function of the unit weight determined in accordance with ASTM C 29.
- c. Maximum fine aggregate: 3 cubic feet per cubic yard and shall be included in the total aggregate volume.
- d. Minimum cement content: 5500 lbs per cubic yard.
- e. Maximum fly ash content: 15% by weight of cement.
- f. Maximum slag: 25% by weight of cement.
- g. Water/cement ratio: 0.25-0.3.
- h. Air Entrainment: 0.78 lbs per cubic yard.
- i. Density: 105 to 125 lbs per cubic foot (tested per ASTM C1688).
- j. Void content: 15%-25% (tested per ASTM C 1688).
- k. Minimum measured in-place infiltration: 3 gallons per minute per square foot in accordance with ASTM C 1701.
- l. Other acceptance criteria:
 - 1) Minimum compressive strength: 3,700 psi.

PART 3 - EXECUTION

3.01 SUBGRADE PREPARATION

- A. Construct subgrade to ensure that required sidewalk thickness is obtained at all locations.
- B. Once exposed, the contractor must protect the subgrade from adverse weather, the Contractor's operations, and traffic.
- C. Compact with a mechanical vibratory compactor to a maximum density of 92% ± 2% of a maximum dry density as established by ASTM D1557. Subgrade that has been over-compacted must be scarified to a minimum depth of 8 inches and compacted to a firm and unyielding condition.
- D. Material used to protect the subgrade from traffic or provide access to adjacent facilities shall be removed prior to placement of subbase.

3.02 FORMS

- A. Construction: To be removable without damage to the concrete.
- B. Coatings: Before placing the concrete, coat the contact surfaces of the forms with a non-staining mineral oil, non-staining form coating compound.
- C. Grade and Alignment: Check and correct elevations and alignment of the forms immediately before placing the concrete.

3.03 MEASURING, MIXING, CONVEYING, AND PLACING CONCRETE

- A. Measuring: ASTM C 94.
- B. Mixing: Truck mixers shall be operated at the speed designated as mixing speed by the manufacturer for 75 to 100 revolutions of the drum.
- C. Conveying: ASTM C 94.
- D. Placing: ACI 522.1, except as modified herein. Do not exceed a free vertical drop of 3 feet from the point of discharge.
- E. Cold Weather: The air temperature must be above 32 degrees Fahrenheit on the day of placement and for seven calendar days prior to placement.
- F. Hot Weather: Maintain required concrete temperature in accordance with Figure 2.1.5 in ACI 305R to prevent evaporation rate from exceeding 0.01 pounds of water per square meter of exposed concrete per hour. Cool ingredients before mixing or use other suitable means to control concrete temperature and prevent rapid drying of newly placed concrete. After placement, use fog spray, spread and remove polyethylene sheeting between finishing operations, apply monomolecular film, or use other suitable means to reduce the

evaporation rate. Start curing when surface of fresh concrete is sufficiently hard to permit curing without damage. Cool underlying material by sprinkling lightly with water before placing concrete. Follow practices found in ACI 305R.

3.04 PAVING

- A. Pavement shall be constructed with paving and finishing equipment utilizing fixed forms or slipforms.
- B. Operation: When the paver is operated between or adjacent to previously constructed pavement (fill-in lanes), provisions shall be made to prevent damage to the previously constructed pavement, including keeping the existing pavement surface free of any debris, and placing rubber mats beneath the paver tracks. Transversely oscillating screeds and extrusion plates shall overlap the existing pavement the minimum possible, but in no case more than 8 inches.
- C. Required Results: The paver-finisher shall be operated to produce a thoroughly consolidated slab throughout, true to line and grade within specified tolerances. The paver-finishing operation shall produce a surface finish free of irregularities, tears, voids of any kind, and any other discontinuities. Multiple passes of the paver-finisher shall not be permitted. No water, other than true fog sprays (mist), shall be applied to the concrete surface during paving and finishing.
- D. Fixed Form Paving: Forms shall be set on firm material cut true to grade so that each form section when placed will be firmly in contact with the underlying layer for its entire base. Forms shall not be set on blocks or on built-up spots of underlying material. Forms shall remain in place at least 12 hours after the concrete has been placed. Forms shall be removed without injuring the concrete.

3.05 FINISHING

- A. Start finishing operations immediately after placement of concrete. Finish pavement surface on both sides of a joint to the same grade. Finish formed joints from a securely supported transverse bridge. Provide hard finishing equipment for use at all times. Transverse and longitudinal surface tolerances shall be in accordance with ACI 117, Section 12.
 - 1. Side Form Finishing: Strike off and screed concrete to the required crown or slope and cross-section by a power-driven transverse finishing machine. Transverse rotating tube or pipe shall not be permitted unless approved by the Landscape Architect. Elevation of concrete shall be such that, when consolidated and finished, pavement surface will be adequately consolidated and at the required grade. Equip finishing machine with two screeds which are readily and accurately adjustable for changes in pavement crown or slope and compensation for wear and other causes. Make as many passes over each area of pavement and at such intervals as necessary to give proper compaction, retention of coarse aggregate near the finished surface, and a surface of uniform texture, true to grade and crown or slope. Do not permit

excessive operation over an area, which will result in an excess of mortar and water being brought to the surface.

- a. Equipment Operation: Maintain the travel of machine on the forms without lifting, wobbling, or other variation of the machine which tend to affect the precision of concrete finish. Keep the tops of the forms clean by a device attached to the machine. During the first pass of the finishing machine, maintain a uniform ridge of concrete ahead of the front screed for its entire length.
- b. Joint Finish: Before concrete is hardened, correct edge slump of pavement, exclusive of edge rounding, in excess of 1/4 inch. Finish concrete surface on each side of construction joints to the same plane, and correct deviations before newly placed concrete has hardened.
- c. Hand Finishing: Strike-off and screed surface of concrete to elevations slightly above finish grade so that when concrete is consolidated, and finished pavement surface is at the indicated elevation. Vibrate entire surface until required compaction and reduction of surface voids is secured with a strike-off template.
- d. Longitudinal Floating: After initial finishing, further smooth and consolidate concrete by means of hand-operated longitudinal floats. Use floats that are not less than 10 feet long and 6-inches wide and stiffened to prevent flexing and warping.

2. Repair of Surface Defects: ACI 301.

3.06 CURING AND PROTECTION

- A. Curing procedures shall begin within 20 minutes of final placement operations. The pavement surface shall be covered with a polyethylene sheet. The cover shall overlap all exposed edges and shall be secured to prevent dislocation due to winds or adjacent traffic conditions.
- B. Protect concrete adequately from injurious action by the covering material, the sun, rain, flowing water, frost, mechanical injury, tire marks and oil stains, and do not allow it to dry out from the time it is placed for a minimum of 7 to 10 days. Do not use membrane-forming compound on surfaces where its appearance would be objectionable. Maintain temperature of air next to concrete above 40 degrees Fahrenheit for the full curing periods.

3.07 FIELD QUALITY CONTROL

- A. Concrete paving shall be subject to Contractor paid testing and inspection as specified in Section 014300 and as follows:

1. Concrete Sampling:
 - a. Collect samples of fresh concrete in accordance with ASTM C 172 during each working day as required to perform tests specified herein. Make test specimens in accordance with ASTM C 31.
 - b. Consistency Tests: Determine slump in accordance with ASTM C 143. Take samples for slump determination from concrete during placement. Perform tests at the beginning of a concrete placement operation and at subsequent intervals to ensure that specification requirements are met. In addition, perform tests each time test beams and cylinders are made.
 2. Tests for Thickness: Measure during concrete placement to determine in-place thickness of concrete pavement.
 3. Tests for Infiltration: Post-construction testing of the pervious concrete surface course is required and must conform to the methods of ASTM C 1701 on the day the plastic sheeting is removed. At least three locations must be used for the test, and they should be spaced evenly across the pervious paving system. Failure to achieve the minimum design infiltration rate of the surface course at one or more location indicates the system cannot be put in service until the system is corrected to yield all passing values. Unlike the test methodology outlined in the ASTM standards, the test results must not be averaged. The maintenance plan must include a log for recording each location and its test result for future reference.
- B. Adjust concrete mixes which do not conform to the specified requirements as follows:
1. Concrete strength shall be considered satisfactory when the minimum of the 28-day test results equals or exceeds the specified 28-day compressive strength, and no individual strength test is less than 2,000 psi. If the ratio of the 7-day strength test to the specified 28-day strength is less than 65 percent, make necessary adjustments for conformance.
- C. Concrete paving which does not conform to the specified requirements shall be removed and replaced as approved by the Landscape Architect.

END OF SECTION 321343

NO TEXT ON THIS PAGE

SECTION 321400 – UNIT PAVING

PART 1 - GENERAL

1.01 DESCRIPTION

- A. Provide unit paving as indicated and in compliance with Contract Documents.
 - 1. Precast Concrete Unit Paving set in Trass Bed.

1.02 PAYMENT

- A. No separate payment shall be made for performing any Work required under this Section. All costs for Work required by this Section shall be included in the applicable lump sum, as set forth in Section 012901.

1.03 REFERENCES

- A. American Society for Testing and Materials (ASTM)
 - 1. ASTM C 33 – Specification for Concrete Aggregates.
 - 2. ASTM C 136 - Standard Test Method for Sieve Analysis of Fine and Coarse Aggregates.
 - 3. ASTM C 920 - Specification for Elastomeric Joint Sealants.
 - 4. ASTM C936 – Standard Specification for Solid Concrete Interlocking Paving Units.
 - 5. ASTM C1028 – Static Coefficient of Friction of Ceramic Tile and Other Like Surfaces by the Horizontal Dynamometer Pull-Meter Method.
 - 6. ASTM D1557 - Standard Test Methods for Laboratory Compaction Characteristics of Soil Using Modified Effort.
 - 7. ASTM D1751 - Standard Specification for Premolded Expansion Joint Filler for Concrete Paving
 - 8. ASTM D2940 - Standard Specification for Graded Aggregate Material for Bases and Sub-bases for Highways and Airports.
- B. Tile Council of America (TCA):
 - 1. Handbook for Ceramic Tile Installation.
- C. American National Standards Institute (ANSI):

- D. Americans with Disabilities Act (ADA). Title III Regulations, 28 CFR Part 36 ADA STANDARDS FOR ACCESSIBLE DESIGN, Appendix A, Section 4.29.2.
- E. International Masonry All-Weather Council: “Guide Specification for Cold-Weather Masonry Construction”.
- F. The New Jersey Administrative Code (N.J.A.C.)
- G. NCMA-TEK, TEK 87- “Construction of Concrete Masonry Pavements”.

1.04 RELATED SECTIONS

- A. General Conditions Article 4.7 – Shop Drawings and Other Submittals.
- B. Section 012901 – Measurement and Payment.
- C. Section 014300 - Quality Requirements.
- D. Section 016100 - Control of Materials.
- E. Section 017423 – Cleaning Up.
- F. Section 017700 - Contract Closeout.
- G. Section 033000 – Cast in Place Concrete
- H. Section 321343 – Pervious Concrete Paving
- I. Section 321560 – Bound Crushed Stone Surfacing
- J. Section 312300 – Excavation and Fill.

1.05 SUBMITTALS

- A. Submit the following in accordance with General Conditions Article 4.7.
 - 1. Product Data: For each type of product indicated including:
 - a. Manufacturer’s catalog product data.
 - b. Installation instructions for all products used in the paver installation.
 - c. Material safety data sheets for the safe handling of the specified materials and products.
 - d. Include manufacturer’s name and address, specific trade names; catalog numbers complete with installation instructions, illustrations, and descriptive literature. Clearly mark or underline proposed items in red; list sources of materials.

B. Samples:

1. General:

- a. All accepted samples become the standard of acceptance for work.
- b. On the basis of a review of the samples, the Construction Manager may require minor modifications to be made. Upon request, re-submittal may be required at Contractor's expense.

2. Paver units:

- a. Four representative full-size samples of each slab type, thickness, color, and finish that indicate the range of color variation and texture expected in the finished installation. Colors selected by Construction Manager from manufacturer's available colors.

3. Metal Edge Restraint:

- a. Two representative 12-inch-long samples of metal edging for use in the installation of the unit paver system exhibiting depth, thickness, color, finish, and anchoring mechanisms of the metal edging expected in the finished installation as indicated in the Contract Documents and to be approved by the Landscape Architect.

C. Shop Drawings: Submit for review and approval plan drawings at 1/8" = 1'-0" showing the locations of concrete unit paver and joining pattern. Shop drawings shall be coordinated with all conditions and show the relationship of all elements that interface the concrete unit paver joining pattern including but not limited to, light fixtures, site furnishings, pedestrian bridge columns, existing bulkheads, Resist Structure foundation slab, curbs, planters and tree pits.

1.06 QUALITY ASSURANCE

A. In accordance with Section 014300.

B. Company specializing in the manufacturing of solid brick and precast concrete unit pavers for a period of five (5) years. Single layer production only; multi-layer production is unacceptable.

C. All work shall be done by experienced and skilled installers of unit pavers with (3) years of experience for both mortared in place and set on the granular setting base.

D. All Federal, State and local laws and regulations governing this work are hereby incorporated into and made a part of this Section. When this Section calls for certain materials, workmanship or a level of construction that exceeds the level of Federal, State or local requirements, the provisions of this Section shall take precedence.

E. On-Site Mock-ups

1. General:
 - a. Do not proceed with work until the mock-up has been reviewed and accepted by Construction Manager.
 - b. Provide a mock-up of each type, pattern, and installation per method for approval.
 - c. Mock-up located within the finish work of construction is not allowed unless approved by Construction Manager.
 - d. Prior to developing a mock-up contractor to submit drawings depicting the layout of the mock-up for approval. Contract Drawings shall show the location of each paver type, joint conditions, and interface with other site elements.
 - e. Accepted mock-up area may remain on site and shall be the standard for performance of the installation.
 - f. Coordinate with Mock-up requirements of other sections for interface with items such as and not limited to concrete paving, tree pits, pedestrian bridge columns, curbs, light poles, and walls.
 - g. All Mock-ups are subject to final approval. If rejected contractor to provide additional mock-ups at no additional cost. If any specific aspect of a mock-up is not conforming to the approved mock-up drawing layout, the Contractor to fix or redo the submittal at no additional cost.
2. Precast Concrete Unit Pavers set in Trass Bed:
 - a. Preliminary Mockup for Color and Finish Verification of product to be used in the final mockup: Construct a preliminary mockup field 48 inch by 72 inch of the full depth unit paver set in Trass Bed system demonstrating the range of paver color, finish and running bond pattern as shown in the Contract Documents.
 - (1) Provide two preliminary mockups for color and texture selection by the Landscape Architect.
 - (2) Retain approved preliminary mockup sample for comparison to final mockup.
 - b. Final Mockup: Install one (1) 20 foot by 20-foot field of unit pavers set in trass bed. The mock-up to demonstrate the full interface of all edge conditions including planting with metal edge, at flush curb, at raised curb, at tree grate, at metal plaza planter, at permeable concrete path, at impervious concrete path, at resin bound aggregate paving, at wall type 1 with metal cladding, at wall type 2, and at wood decking stair. Additionally, mock-up to convey joint sizes, joint types, lines, laying pattern, randomized color mix patterning, and location of cut pavers and treatment.

(3) Mockup types to include:

- (a) Off-site installation: An area that is constructed outside of the field of work and to be protected throughout the project. This mockup once approved it shall be the standard from which the work will be judged.
- (b) First in place: These are locations in the site to verify that installation is in conformance to the approved Off-site mockup. Mock-up may be retained as a part of the finished work upon approval by Landscape Architect and the Construction Manager. If mock-up is not retained, remove and dispose of mock-up prior to the completion of the project.

c. All mock-ups are subject to approval by Landscape Architect and the Construction Manager.

F. Before commencing installation at the site, conduct a pre-construction conference to be attended by the Contractor, Paver installer, Paver Supplier, Landscape Architect, and Construction Manager. Review the field-constructed mock-ups, availability of materials, schedules, procedures and other matters relating to the paver installation. Proceed after all questions regarding the work have been resolved.

1.07 DELIVERY, STORAGE, AND HANDLING

- A. Comply in accordance with Section 016100.
- B. Deliver and store packaged materials in original containers with seals unbroken and labels intact until time of use.
- C. Notify the Construction Manager 7 Calendar Days prior to the time of delivery.
- D. Store pavers and materials on level, elevated platforms, undercover, and in a dry location. Any cement delivered to a job shall be packed in strong paper of jute bags with brand name and manufacturer's name stamped thereon. Cement shall be stored under cover and should it become wet or show signs of caking or deterioration of any kind, it shall be immediately removed from the site. Concrete materials shall be protected from contamination.

1.08 PROJECT CONDITIONS

- A. Do not proceed with installation when substrate / sub-grades conditions are not suitable for installation of unit pavers. This includes but is not limited to temperatures, sub-grade compaction, tree installation, utility structures. The Contractor shall become familiar with existing site conditions and obtain other information as may be necessary for a complete

installation. Notify the Construction Manager of unsatisfactory conditions prior to the commencement of work.

- B. Exercise care in excavating and working near existing utilities. The Contractor shall be responsible for damages to utilities which are caused by the Contractor's operations or neglect. Check existing utility drawings for existing utility locations.
- C. Repair or replace existing improvements which are not designated for removal which are damaged or removed as a result of the Contractor's operations. Repairs and replacements shall be equal to existing improvements and shall match them in finish and dimension.
- D. Costs for protecting, removing, and restoring existing improvements shall be at the Contractor's expense.
- E. Cold-Weather Protection: Do not use frozen materials or materials mixed or coated with ice or frost. Do not build on frozen subgrade or setting beds. Remove and replace unit paver work damaged by frost or freezing.
- F. Weather Limitations: Protect unit paver work against freezing when the atmospheric temperature is 40 degrees Fahrenheit (4 degrees Centigrade) and falling. Heat materials and provide temporary protection of completed portions of unit paver work. Comply with International Masonry All-Weather Council's "Guide Specification for Cold-Weather Masonry Construction," Section 04200, Article 3.
- G. Hot-Weather Requirements: Protect unit paver work when temperature and humidity conditions produce excessive evaporation of setting beds and grout. Provide artificial shade and windbreaks and use cooled materials as required. Do not apply mortar to substrates with temperatures of 80 degrees Fahrenheit (27 degrees Centigrade) and above.

1.09 VERIFICATIONS OF DIMENSIONS AND QUANTITIES

- A. Verify scaled dimensions and quantities prior to the start of work.
- B. Notify the Construction Manager of discrepancies between Contract Drawings and Contract Sections and actual job site conditions which would affect the execution of the installation work. Do not work in areas where discrepancies occur until instructed by the Construction Manager.

1.10 COORDINATION

- A. Contractor shall be responsible for sequencing the placement of concrete unit to minimize disturbance of existing surfaces.
- B. Contractor shall notify the Construction Manager of the installation of the work in ample time, so as to allow sufficient time for coordination.

1.11 WARRANTY

- A. Warrant the pavers to be free from defect for a period of 12 months from the date of substantial completion. The warranty shall include defective work, breakage, deformation, fading and loosening of tiles.
- B. Warrant the metal edge restraint to be free from defect or failure for a period of fifteen (15) years from the date of purchase.

1.12 EXTRA STOCK (ATTIC STOCK)

- A. Deliver extra paver stock to a storage area designated by Construction Manager. Furnish new materials from the same manufactured lot as materials installed and enclosed in protective packaging with appropriate identification.
- B. Furnish not less than two percent of the supplied pavers for each type, color and pattern installed.

PART 2 - PRODUCTS

2.01 UNIT PAVERS

- A. Pre-cast Permeable Concrete Unit Pavers
 - 1. Pre-cast permeable concrete unit pavers, H-Series, as provided by:
 - a. Wasau Tile, 9001 Bus Hwy 51, Rothschild, WI 54474; Telephone: 715-359-3121; Email: wtile@wasautile.com; Web: www.wasautile.com
 - 2. Material Sizes:
 - a. 12"x24"x4"
 - 3. Color:
 - a. HRL 37, 30% of total area. Pattern as per Contract Drawings.%
 - b. HFT 15, 70% of total area. Pattern as per Contract Drawings.%

2.02 TRASS BED COMPOUND

- 1. Rompox TRAS-BED compound, as provided by:
 - a. Romex Permeable Hardscapes, 260 Riverside Drive, North Vancouver, BC V7H2M2; Telephone: 604-913-1579; Email: info@romex.us; Web: www.romex.us

2.03 BASE COURSE

- A. Permeable Aggregate Base Course: Section 312300.

- B. Geotextile Fabric: Section 312300.
- C. Choker Course: Section 312300.
- D. Storage Gravel: Section 312300.

2.04 ADHESION ELUTRIANT

- A. Rompox Adhesion Elutriant, containing trass cement and tempered with polymers. Resistant to weeds and ants. As provided by
 - 1. Romex Permeable Hardscapes, 260 Riverside Drive, North Vancouver, BC V7H2M2; Telephone: 604-913-1579; Email: info@romex.us; Web: www.romex.us

2.05 JOINTING MORTAR

- A. Rompox D1 2-Component Paver Jointing Mortar for medium traffic loads, as provided by:
 - 1. Romex Permeable Hardscapes, 260 Riverside Drive, North Vancouver, BC V7H2M2; Telephone: 604-913-1579; Email: info@romex.us; Web: www.romex.us
- B. Color:
 - 1. Stone Grey

2.06 METAL EDGE RESTRAINT

- A. Metal edge restraint 3 inches by 3 inches with 0.210 inch (5.33 mm) thick exposed top lip x 8 feet (2.44 meters) long, extruded aluminum, alloy 6005, T-5 hardness. Horizontal base to have upward facing angle profile designed to integrate restraint and asphalt surfaces for straight-line and curvilinear applications. Section shall have holes in base spaced 4 inches (102 mm) apart along its length to receive anchors.
- B. Connection Method: Section ends shall splice together with horizontal 0.060 inch (1.52 mm) thick x 1 inch (25 mm) wide, or 0.530 inch (13.5 mm) wide for 1 inch (25 mm) high edging x 4 inches (102 mm) long aluminum sliding connector.
- C. Anchors: 3/8-inch x 10 inches (9.5 mm x 254 mm) bright spiral steel spike.
- D. Finish: Mill Finish.
- E. As Supplied By:
 - 1. Permaloc Corporation, 13505 Barry Street, Holland, MI 49424; Telephone: 616-339-9600; Email: info@permaloc.com; Web: www.permaloc.com

2. Sure-loc Edging, 310 E 64th Street, Holland, MI 49423; Telephone: 800-787-3562; Email: info@surelocedging.com; Web: www.surelocedging.com
3. Curv-Rite, Inc; Wayland, MI, USA; Telephone: 800-366-2878; Email: john@curv-rite.com; Web: www.curv-rite.com
4. Or approved equal.

PART 3 - EXECUTION

3.01 EXAMINATION AND PREPARATION

A. Unit Pavers:

1. The areas to receive unit pavers will be inspected to assure existing sub-grade is meeting the maximum relative compaction rate. If compaction rates do not meet required compaction rates the Contractor shall make necessary adjustments and re-compacted.

B. Examine surfaces indicated to receive paving, with Installer present, for compliance with requirements for installation tolerances and other conditions affecting the performance of unit pavers. Do not proceed with installation until unsatisfactory conditions have been corrected.

C. Proof roll prepared the sub-grade surface to check for unstable areas and areas requiring additional compaction. Do not proceed with installation of pavers until deficient sub-grades have been corrected and are ready to receive sub-base for unit pavers.

3.02 UNIT PAVER INSTALLATION ON TRASS BED

A. The subsurface needs to be made load bearing, firm and water permeable. Water impermeable load distribution layers (screeds), such as areas with house utility connections as well as any slab coverings that are laid, need to have a slope of at least 1,5–3,0 percent. Any water that gathers needs to be drained with corresponding drainage measures. In case of any watertight outdoor areas and levels where water flows and partial puddles form, it is recommended installing a suitable capillary-breaking drainage mat.

B. Install Storage Gravel in accordance with Section 312300

C. Install Choker Course in accordance with Section 312300

D. Install Geotextile Fabric in accordance with Section 312300

E. Install Permeable Aggregate Base Course in accordance with Section 312300

F. Mix ROMPOX® - TRASS-BED-COMPOUND in a ratio of 1:4 with filler material (i.e., rolled grit/gravel 4–8 mm | 1/8” - 3/8”) so that it is earth damp, mixing time 2–3 minutes.

Water requirement approx. 11 liters | 2.9 gals of cool, clean water per used 25 kg ROMPOX® - TRAS-BEDCOMPOUND. To do this, mix ROMPOX® - TRAS-BEDCOMPOUND with filler material and first add approx. 9 liters | 2.4 gals of water. Keep adding water to the mix until the mortar mixture is slightly shiny and can be rolled into a firm ball. Mix using a pug mill mixer or gravity mixer. For smaller amounts, mixing can be done in a wheelbarrow or mortar tub. After mixing, the mortar is ready for immediate use. Where possible, use the entire container, otherwise weigh the exact amounts needed.

- G. The thickness of the bedding mortar should generally be 4–10 cm | 1 1/2- inch – 4 inches deep depending on expected loads (load classification / usage category) and stone. (Exception is mixed construction method for usage category N2 of ZTV path construction with a thickness of ≥ 10 cm | ≥ 4 inches.) Lay the ready mixed bedding mortar loosely. The connection elements to be used are pre-treated with ROMPOX® - ADHESION ELUTRIANT and laid at the correct height and hammer-hard into their final position. When filling the joints, at least 3 cm | 1 1/4-inch joint depth from the top edge of the stone is required, in case of traffic loads at least 2/3 the height of the stone.
- H. After installation of Trass Bed Compound, install metal edge restraint.
 - 1. Prepare the sub-base and aggregate base course and trass bed course prior to installation of metal edge restraint. The base must be properly compacted and extend 6 to 12 inches beyond the edge of the pavement installation. The base immediately beneath the restraint must be consistent or “level.”
 - 2. Allow for expansion of metal edge restraint during paving installation per manufacturer’s recommendation and per the pavement type adjacent to metal edge restraint.
 - 3. Set and anchor according to manufacturer’s recommendation. Anchor the ends of each section. For added stability, use additional spikes.
 - 4. Corners should be made by bending a single section to form the angle. Additional cutting of the base may be required for tight angles.
 - 5. Lay pavers adjacent to metal edge restraint with finish surface of paver no less than 1/2 inch and nor more than 1 inch above the top of metal edge restraint.
 - 6. Backfill and compact adjacent topsoil within 1/2-inch of the top of the metal edge restraint.
- I. Ensure the pavers are free from foreign materials before installation.
- J. Lay the pavers on the setting bed trass bed material with adhesion elutriant per manufacturers recommendations in the pattern shown on the approved shop drawings. Pavers shall be placed in such a manner that the desired pattern is maintained, and paver joints are butted. Maintain straight joint lines. Gaps between pavers shall not exceed 1/4 inch. Use string lines to hold all patterns true and straight.

- K. Set unit pavers with a minimum joint width of 3/16 inch (0.48 cm), being careful not to disturb leveling base. If pavers have spacer bars, then place pavers hand tight against spacer bars. Use string lines to keep straight lines. Select units from 4 or more cubes to blend color and texture variations. Fill gaps between units that exceed 3/16 inch (0.48 cm) with pieces cut to fit from full-size unit pavers.
- L. Pavers to be alternately selected from at least three (3) pallets, working from top to bottom in each pallet stack.
- M. Cut concrete unit pavers with a masonry saw. Layout of paver system so no cut paver is smaller than 1/3 of a whole unit.
- N. Clean out joints to a depth of at least 30 mm | 1 1/4 inch (in case of traffic loads 2/3 of stone height, minimum joint width 3 mm | 1/8 inch). The surface to be joint-fixed should be cleaned of all impurities before work commences. Adjoining surfaces that are not to be joint-fixed are taped off.
- O. Pre-wet the surface. Porous surfaces as well as higher surface temperatures, require more intense pre-wetting.
- P. Pour the 25 kg | 55 lb ROMPOX D1 filler components into the mixing tub and start the mixing process. Whilst mixing, slowly add the separately packaged 2.5 kg | 5.5 lbs resin/hardener component completely into the mixture. In order to fully use the contents of the bottle, both bottles should be rinsed with water. To do this, fill up the two previously emptied resin / hardener bottles with 0.5 liters | 0.13 gal of water, close, shake vigorously and add the contents of the bottle to the mixture. After mixing for 3 minutes add 3 liters | 0.8 gal of water and continue mixing well for at least 3 minutes. Use professional agitator or rotary-drum mixer / compulsory mixer. Mixing bucket: Open the bucket, open bottles within and pour the contents completely into the filler material component. In order to fully use the contents of the bottle, both bottles should be rinsed with water. To do this, fill up the two previously emptied resin/hardener bottles with 250 ml | 0.13 gals of water, close, shake vigorously and add the contents of the bottle to the mixture. Start the mixing process. Do not add water. Total mixing time: at least 6 minutes. Use professional agitator or rotary-drum mixer / compulsory mixer.
- Q. Apply the mixed pavement jointing mortar onto the well moistened surface and work it carefully into the joints using a squeegee/rubber slider. The mortar is poured out at three or four spots within the jointing area in order to make best use of the fluidity of the pavement jointing mortar. If the ready mixed mortar is not used up straight away, before continuing with application and remaining within the stated application time, mix the remaining mortar through again briefly to ensure it has optimum flow capability. All tools as well as work shoes should be regularly cleaned with a water spray during jointing, to avoid impurities by binding agent and footprints on the stone surface.

- R. After approx. 10–15 minutes the excess mortar on the surface of the stones can be swept off carefully with a large, coarse broom. Then use a soft, hair broom to do a final cleaning until all residual mortar has been removed from the surface. The correct moment for sweeping, is when white smears no longer form on the stone surface during sweeping. Sweeping should be done diagonally to the joint. Do not reuse swept off material. The freshly jointed surface needs to be protected against rain for the next 12–24 hours. The rain protection layer must not be laid directly onto the paved surface, to ensure sufficient air circulation. After sweeping the surface clean, check final elevations for conformance to the Contract Drawings.
1. Lippage: No greater than 1/8 in. (3 mm) the difference in height between adjacent pavers.
 2. The surface of the pavers maybe 1/8 to 1/4 in. (3 to 6 mm) above the final elevations after compaction.
- S. After all, surfaces are clean and dry install sealer in accordance with manufacturer’s requirements and specifications.

3.03 EXPANSION JOINTS

- A. Provide joints at locations at intervals shown on the Contract Drawings and approved shop drawings or as specified herein.
- B. All expansion joint filler strips shall be installed vertically and extend to the full depth and width of the work in which they are installed and be constructed perpendicular to straight curb or radially to the line of the curb constructed on a curve. During placing and tamping of the concrete, the expansion joint shall be held rigidly and securely in proper position.
- C. After curing period, carefully clean expansion joints and fill with joint compound as shown on the Contract Drawings.
- D. Do not permit spillage on paved surfaces or overflow from the joint.

3.04 CLEANING AND PROTECTING

- A. Protect pavers against damage during the construction period to comply with manufacturer’s specifications.
- B. Remove and replace unit pavers that are loose, chipped, broken, stained, or otherwise damaged or if units do not match adjoining units as intended. Provide new units to match adjoining units and install in same manner as original units, with same joint treatment to eliminate evidence of replacement.

3.05 CLEANUP

- A. Provide in accordance with Section 017423

3.06 CONTRACT CLOSEOUT

- A. Provide in accordance with Section 017700.

END OF SECTION 321400

NO TEXT ON THIS PAGE

SECTION 321560 – BOUND CRUSHED STONE SURFACING

PART 1 - GENERAL

1.01 DESCRIPTION

- A. Provide bound crushed stone surfacing as indicated and in compliance with Contract Documents.
 - 1. Resin Bonded Aggregate Paving

1.02 PAYMENT

- A. No separate payment shall be made for performing any Work required under this Section. All costs for Work required by this Section shall be included in the applicable lump sum, as set forth in Section 012901.

1.03 REFERENCES

- A. American Society for Testing and Materials (ASTM)
 - 1. ASTM D1557 - Standard Test Methods for Laboratory Compaction Characteristics of Soil Using Modified Effort.
 - 2. ASTM D2922 – Test Methods for Density of Soil and Soil-Aggregate in Place by Nuclear Methods (Shallow Depth), Method B (Direct Transmission).
 - 3. ASTM D2940 - Standard Specification for Graded Aggregate Material for Bases and Sub-bases for Highways and Airports.
- B. American National Standards Institute (ANSI):
- C. Americans with Disabilities Act (ADA). Title III Regulations, 28 CFR Part 36 ADA STANDARDS FOR ACCESSIBLE DESIGN, Appendix A, Section 4.29.2.
- D. The New Jersey Administrative Code (N.J.A.C.)

1.04 RELATED SECTIONS

- A. General Conditions Article 4.7 – Shop Drawings and Other Submittals.
- B. Section 012901 – Measurement and Payment.
- C. Section 014300 - Quality Requirements.
- D. Section 016100 - Control of Materials.

- E. Section 017423 – Cleaning Up
- F. Section 017700 - Contract Closeout.
- G. Section 312300 – Excavation and Fill

1.05 SUBMITTALS

- A. Submit the following in accordance with General Conditions Article 4.7.
 - 1. Product Data: For each type of product indicated including:
 - a. Manufacturer’s catalog product data.
 - b. Installation instructions for all products used in the bound crushed stone surfacing installation.
 - c. Material safety data sheets for the safe handling of the specified materials and products.
 - d. Include manufacturer’s name and address, specific trade names; catalog numbers complete with installation instructions, illustrations, and descriptive literature. Clearly mark or underline proposed items in red; list sources of materials.
- B. Samples:
 - 1. General:
 - a. All accepted samples become the standard of acceptance for work.
 - b. On the basis of a review of the samples, the Construction Manager may require minor modifications to be made. Upon request, re-submittal may be required at Contractor’s expense.
 - 2. Resin Bound Aggregate Paving:
 - a. Four representative samples of resin bound aggregate paving exhibiting proposed thickness, color, and finish that indicate the range of color variation and texture expected in the finished installation as indicated in the Contract Drawings and to be approved by the Landscape Architect.
 - 3. Two representative 12-inch-long samples of metal edging for use in the installation of the resin bound aggregate paving system exhibiting depth, thickness, color, finish, and anchoring mechanisms of the metal edging expected in the finished installation as indicated in the Contract Documents and to be approved by the Landscape Architect.

1.06 QUALITY ASSURANCE

- A. In accordance with Section 014300.

- B. Company specializing in the manufacturing of bound crushed stone surfacing (both aggregate and binding agent) for a period of five (5) years.
- C. All work shall be done by experienced and skilled installers of bound crushed stone surfacing with five (5) years of experience in the type of bound aggregate paving installation specified herein and as shown on the Contract Drawings in addition to the requirements in Section 014300. Installers shall be certified by manufacturer of the bound crushed stone surfacing material for installation of the manufacturer's product.
- D. All Federal, State and local laws and regulations governing this work are hereby incorporated into and made a part of this Section. When this Section calls for certain materials, workmanship or a level of construction that exceeds the level of Federal, State or local requirements, the provisions of this Section shall take precedence.
- E. On-Site Mock-ups
 - 1. General:
 - a. Do not proceed with work until the mock-up has been reviewed and accepted by Construction Manager.
 - b. Provide a mock-up of each type, pattern, and installation per method for approval.
 - c. Mock-up located within the finish work of construction is not allowed unless approved by Construction Manager.
 - d. Prior to developing a mock-up contractor to submit drawings depicting the layout of the mock-up for approval.
 - e. Accepted mock-up area may remain on site and shall be the standard for performance of the installation.
 - f. Coordinate with Mock-up requirements of other sections for interface with items such as and not limited to concrete paving, unit paving, tree pits, planting, light poles, and walls.
 - g. All Mock-ups are subject to final approval. If rejected contractor to provide additional mock-ups at no additional cost. If any specific aspect of a mock-up is not conforming to the approved mock-up drawing layout, the Contractor to fix or redo the submittal at no additional cost.
 - 2. Resin Bound Aggregate Paving:
 - a. Preliminary Mockup for Color and Finish Verification of product to be used in the final mockup: Construct a preliminary mockup field 36 inch by 48 inch of the full depth bonded crushed stone surfacing system demonstrating the range of color surface aggregate installed of the aggregate system.
 - (1) Provide four preliminary mockups for color and texture selection by the Landscape Architect.

- (2) Retain approved preliminary mockup sample for comparison to final mockup.
 - b. Final Mockup: Construct a 15-foot by 15-foot full depth installation of bonded crushed stone field. Final mockup to be approved by the Landscape Architect and Construction Manager.
 - (1) Mockup types to include:
 - (a) Off-site installation: An area that is constructed outside of the field of work and to be protected throughout the project. The mock-up to demonstrate the full interface of all edge and geometry conditions including at planting with metal edge, at unit pavers, at decking, at raised concrete curb, at wall type 2, at permeable concrete path, at impervious concrete path, and curved plan geometries with wedge conditions representative of the plan geometries as shown on the Contract Drawings. This mockup once approved it shall be the standard from which the work will be judged.
 - (b) First in place: These are locations in the site to verify that installation is in conformance to the approved Off-site mockup. Mock-up may be retained as a part of the finished work upon approval by Landscape Architect and the Construction Manager. If mock-up is not retained, remove and dispose of mock-up prior to the completion of the project.
 - (2) All mock-ups are subject to approval by Landscape Architect and the Construction Manager.
- F. Preconstruction Meeting:
- 1. Before commencing installation at the site, conduct a pre-construction conference to be attended by the Contractor, Bound Crushed Stone Surfacing Installer, Bound Crushed Stone Surfacing Supplier, Landscape Architect, and Construction Manager. Review the field-constructed mock-ups, availability of materials, schedules, procedures and other matters relating to the stone installation. All associated work in proximity to bound crushed stone surfacing areas must be completed prior to installation of bound crushed stone surfacing, including but not limited to adjacent pavements, retaining walls, decking, amphitheater seating, precast concrete steps, curbs, finish grading, and planting. Prepare for the protection of the completed Work in accordance with this Section. Proceed only after adjacent work has been completed, and after all questions regarding the work have been resolved.

1.07 DELIVERY, STORAGE, AND HANDLING

- A. Comply in accordance with Section 016100
- B. Deliver aggregates in sealed bags clearly labeled as to manufacturer and material color intact until time of use.
- C. Notify the Construction Manager 7 Calendar Days prior to the time of delivery.
- D. Store aggregate protected from moisture and weather.
- E. Store liquids in tightly closed containers protected from excessive heat or freezing.

1.08 PROJECT CONDITIONS

- A. Do not proceed with installation when substrate / sub-grades conditions are not suitable for installation of bound crushed stone surfacing. This includes but is not limited to temperatures, sub-grade compaction, tree installation, utility structures. The Contractor shall become familiar with existing site conditions and obtain other information as may be necessary for a complete installation. Notify the Construction Manager of unsatisfactory conditions prior to the commencement of work.
- B. Exercise care in excavating and working near existing utilities. The Contractor shall be responsible for damages to utilities which are caused by the Contractor's operations or neglect. Check existing utility drawings for existing utility locations.
- C. Repair or replace existing improvements which are not designated for removal which are damaged or removed as a result of the Contractor's operations. Repairs and replacements shall be equal to existing improvements and shall match them in finish and dimension.
- D. Costs for protecting, removing, and restoring existing improvements shall be at the Contractor's expense.
- E. Cold-Weather Protection: Do not use frozen materials or materials mixed or coated with ice or frost. Do not build on frozen subgrade or setting beds. Remove and replace bound crushed stone surfacing work damaged by frost or freezing.
- F. Weather Limitations: Install bound crushed stone surfacing when temperatures are between 40 degrees Fahrenheit (4 degrees Centigrade) and 85 degrees Fahrenheit (30 degrees Centigrade) or modified temperature range per recommendations of selected manufacturer. If selected manufacturer's recommended temperature installation range varies from that listed herein, submit revised acceptable temperature ranges for installation documenting temperature limitations in writing to Landscape Architect for approval. Bound crushed stone surfacing should not be installed during wet weather. Plan work when weather conditions are expected to meet the manufacturer's

recommendations. If it starts to rain during application stop work and protect installed area from moisture.

1.09 VERIFICATIONS OF DIMENSIONS AND QUANTITIES

- A. Verify scaled dimensions and quantities prior to the start of work.
- B. Notify the Construction Manager of discrepancies between Contract Drawings and Contract Sections and actual job site conditions which would affect the execution of the installation work. Do not work in areas where discrepancies occur until instructed by the Construction Manager.

1.10 COORDINATION

- A. Contractor shall be responsible for sequencing the placement of bound crushed stone surfacing to minimize disturbance of existing surfaces.
- B. Contractor shall notify the Construction Manager the installation of the work in ample time, so as to allow sufficient time for coordination.

1.11 WARRANTY

- A. Warrant the bound crushed stone surfacing to be free from defect for a period of three (3) years from the date of substantial completion. The warranty shall include defective work, breakage, deformation, fading and loosening.
- B. Warrant the metal edge restraint to be free from defect or failure for a period of fifteen (15) years from the date of purchase.

PART 2 - PRODUCTS

2.01 BOUND CRUSHED STONE SURFACING SYSTEM

- A. Resin Bonded Surfacing system consisting of aggregate particles, bonded with two-part chemically curing, UV stable, flexible resin, hand applied, as provided by:
 - 1. Chameleon Ways – Basis of Design
 - a. Chameleon Ways, PO Box 387, Center Valley, PA 18034; Telephone: 877-426-5687; Web: www.chameleonways.com
 - b. Product: ADDASET Resin Bound Decorative Surfacing.
 - (1) Aggregate:

- (a) General: ADDASET aggregates consist of differing combinations of coarse and fine aggregates, which meet a specific mix design dependent on the application. Mix designs take into account the final color desired and anticipated traffic and pedestrian usage. Refer to manufacturer’s recommendations for proper mix design. Aggregates are double washed, dried, and bagged by weight.
 - (b) Nominal Color: Lucerne Silver, Granite
 - (c) Nominal Size: 3mm – 6mm
 - (2) Unsaturated Polyester Resin
 - (a) Color: Clear, UV Resistant
- 2. Complete Streets USA
 - a. Complete Streets USA, Telephone: 866-367-3232, Email: info@completestreetsusa.com, Web: www.completestreetsusa.com
 - b. [Product: GeoPaveX Permeable Resin Bound Pavement](#)
 - (1) Aggregate:
 - (a) Nominal Color: Sterling Silver
 - (b) Nominal Size: 1mm – 5mm
 - (2) 2-Component Polyurethane Resin
 - (a) Color: Neutral Amber, UV Resistant
- 3. Romex Permeable Hardscapes.
- 4. Or approved equal.

2.02 SUBSTRATE FOR BOUND CRUSHED STONE SURFACING

- A. Substrate for Bound Crushed Stone Surfacing: In accordance with Section 312300
 - 1. Permeable Aggregate Base Course: Section 312300
 - 2. Geotextile Fabric: Section 312300
 - 3. Choker Course: Section 312300
 - 4. Storage Gravel: Section 312300

2.03 METAL EDGE RESTRAINT

- A. Metal edge restraint 1.5 inch by 2.25 inch with 0.210 inch (5.33 mm) thick exposed top lip x 8 feet (2.44 meters) long, extruded aluminum, alloy 6005, T-5 hardness. Horizontal base to have upward facing angle profile designed to integrate restraint and asphalt surfaces for straight-line and curvilinear applications. Section shall have holes in base spaced 4 inches (102 mm) apart along its length to receive anchors.
- B. Connection Method: Section ends shall splice together with horizontal 0.060 inch (1.52 mm) thick x 1 inch (25 mm) wide, or 0.530 inch (13.5 mm) wide for 1 inch (25 mm) high edging x 4 inches (102 mm) long aluminum sliding connector.
- C. Anchors: 3/8 inch x 10 inches (9.5 mm x 254 mm) bright spiral steel spike.
- D. Finish: Mill Finish.
- E. As Supplied By:
 - 1. Permaloc Corporation, 13505 Barry Street, Holland, MI 49424; Telephone: 616-339-9600; Email: info@permaloc.com; Web: www.permaloc.com
 - 2. Sure-loc Edging, 310 E 64th Street, Holland, MI 49423; Telephone: 800-787-3562; Email: info@surelocedging.com; Web: www.surelocedging.com
 - 3. Curv-Rite, Inc; Wayland, MI, USA; Telephone: 800-366-2878; Email: john@curv-rite.com; Web: www.curv-rite.com
- F. Or approved equal.

PART 3 - EXECUTION

3.01 EXAMINATION AND PREPARATION

- A. Bound Crushed Stone Surfacing:
 - 1. The areas to receive bound crushed stone surfacing will be inspected to assure existing sub-grade is meeting the maximum relative compaction rate. If compaction rates do not meet required compaction rates the Contractor shall make necessary adjustments and re-compacted.
- B. Examine surfaces indicated to receive bound crushed stone surfacing, with Installer present, for compliance with requirements for installation tolerances and other conditions affecting the performance of bound crushed stone surfacing. Do not proceed with installation until unsatisfactory conditions have been corrected.
- C. Proof roll prepared the sub-grade surface to check for unstable areas and areas requiring additional compaction. Do not proceed with installation of bound crushed stone surfacing

until deficient sub- grades have been corrected and are ready to receive base course for bound crushed stone surfacing.

3.02 BASE COURSE PREPARATION

- A. Install Storage Gravel in accordance with Section 312300
- B. Install Choker Course in accordance with Section 312300
- C. Install Geotextile Fabric in accordance with Section 312300
- D. Install Permeable Aggregate Base Course in accordance with Section 312300,

3.03 METAL EDGE RESTRAINT INSTALLATION

- A. Prepare the sub-base and aggregate base course. The base must be properly compacted and extend 6 to 12 inches beyond the edge of the pavement installation. The base immediately beneath the restraint must be consistent or “level”.”
- B. Allow for expansion of metal edge restraint during paving installation per manufacturer’s recommendation and per the pavement type adjacent to metal edge restraint.
- C. Set and anchor according to manufacturer’s recommendation. Anchor the ends of each section. For added stability, use additional spikes.
- D. Corners should be made by bending a single section to form the angle. Additional cutting of the base may be required for tight angles.
- E. Lay pavement adjacent to and flush with the top of metal edge restraint. Ensure that proper compaction of the pavement system is accounted for based on bound crushed stone surfacing manufacturer’s recommendations to leave a final condition of finish grade as flush with top of metal edge restraint.
- F. Following completion of the paving installation, backfill and compact adjacent topsoil within 1/2-inch of the top of the metal edge restraint.

3.04 BOUND CRUSHED STONE SURFACING MIXING AND INSTALLATION

- A. Comply with the manufacturer’s written instructions.

3.05 INSTALLATION TOLERANCES

- A. Edge Conditions: Meet adjacent walking surfaces flush without lippage.
- B. Do not exceed 1/8 inch in 10 feet from level, or indicated slope, for finished surface of paving.

C. Protection and Curing:

1. Set Time: Per manufacturer's recommendations at application temperature.
2. Cure Time: Per manufacturer's recommendations at application temperature.
3. Protect the installation area during the set time and cure time per manufacturer's recommendations. Restrict all access to install area during the set and cure time. No construction activities are to occur over the material during the set or cure time periods.

3.06 REPAIRING

- A. Remove and replace areas that are loose, chipped, broken, stained, or otherwise damaged or that do not match adjoining areas. Provide new application to match adjoining units and install in same manner as original with no evidence of replacement.

3.07 CLEANING AND PROTECTING

- A. Cleaning: Remove and dispose of excess aggregate over two to three weeks by sweeping surface.
- B. Protect bound crushed stone surfacing against damage during the construction period to comply with manufacturer's specifications.
 1. Place all-weather 1/2-inch to 3/4-inch plywood protection over fully cured bound crushed stone surfacing before operating vehicles across the surface.
 2. Prevent dirt, dust and debris from clogging the open pore surface.

3.08 CLEANUP

- A. Provide in accordance with Section 017423

3.09 CONTRACT CLOSEOUT

- A. Provide in accordance with Section 017700.

END OF SECTION 321560

SECTION 321600 - CONCRETE CURBS, GUTTERS, AND SIDEWALKS

PART 1 - GENERAL

1.01 DESCRIPTION

- A. Provide concrete curbs, gutters, and sidewalks as indicated and in compliance with Contract Documents.

1.02 PAYMENT

- A. All costs for Work required by this Section shall be included in the applicable unit price as set forth in Section 012901.

1.03 REFERENCES

- A. ASTM International (ASTM):
 1. A82/A82M: Standard Specification for Steel Wire, Plain, for Concrete Reinforcement.
 2. A185/A185M: Standard Specification for Steel Welded Wire Reinforcement, Plain, for Concrete.
 3. A497/A497M: Standard Specification for Steel Welded Wire Reinforcement, Deformed, for Concrete.
 4. C33/C33M: Standard Specification for Concrete Aggregates.
 5. C1602/C1602M: Standard Specification for Mixing Water Used in the Production of Hydraulic Cement Concrete.
 6. D1190: Standard Specification for Concrete Joint Sealer, Hot-Applied Elastic Type (Withdrawn).
 7. D6690: Standard Specification for Joint and Crack Sealants, Hot Applied, for Concrete and Asphalt Pavements.
- B. NJDOT Specifications: New Jersey Department of Transportation (NJDOT) Standard Specifications for Road and Bridge Construction, current edition.
- C. American Association of State Highway and Transportation Officials (AASHTO):
 1. T26: Standard Method of Test for Quality of Water to Be Used in Concrete.

1.04 RELATED SECTIONS

- A. General Condition Article 4.7 – Shop Drawings and Other Submittals.
- B. Section 012910 – Measurement and Payment
- C. Section 014300 - Quality Requirements.
- D. Section 016100 - Control of Materials.
- E. Section 017700 - Contract Closeout.
- F. Section 031000 - Concrete Formwork.
- G. Section 032100 – Concrete Reinforcement
- H. Section 033000 - Cast-in-place Concrete.
- I. Section 312300 - Excavation and Fill.

1.05 SUBMITTALS

- A. Submit the following in accordance with General Condition Article 4.7.
 - 1. Refer to Section 033000 for required material submissions

1.06 QUALITY ASSURANCE

- A. Comply with the requirements specified in Section 014300.

1.07 DELIVERY STORAGE AND HANDLING

- A. Comply with the requirements specified in Section 016100.

PART 2 - PRODUCTS

2.01 MATERIALS

- A. Water: Potable water or within the limits of AASHTO T26.
- B. Aggregate Base: Minimum 4 inches thick, unless noted otherwise.
 - 1. Dense-Graded Aggregate: NJDOT Specifications, Section 901.10. The Qualified Products List (QPL) can be found at <https://www.state.nj.us/transportation/eng/materials/qualified/QPLDB.shtm>.

2. ¾” Clean Stone: NJDOT Specifications, Section 901.03. Use Table 901.03.02-1, Requirements for Washed Gravel.

2.02 CONCRETE FORMWORK

- A. Forms: Section 031000.

1. Forms shall be made of steel or wood or other material capable of supporting concrete and mechanical concrete placing equipment that is sufficiently rigid to maintain the specified tolerances.
2. Forms shall be clean and free of dirt, rust, and hardened concrete.

2.03 CONCRETE

- A. Concrete: NJDOT Specifications, Section 903.03. Use Table 903.03.06-1, Requirements for Roadway Concrete Items.

2.04 CONCRETE REINFORCEMENT

- A. Comply with the requirements of Section 032100.
- B. Reinforcing Steel: Reinforcing steel, steel welded wire reinforcement (WWR), and dowels according to NJDOT Specifications, Section 905.01.

2.05 SIDEWALKS

- A. Concrete: Pedestrian Areas: 4 inches thick; Driveways: 6 inches thick, unless noted otherwise.
- B. Reinforcing Steel: Reinforcing steel, steel welded wire reinforcement (WWR), and dowels according to NJDOT Specifications, Section 905.01.

2.06 DUMPSTER PADS

- A. Concrete: 6 inches thick, unless noted otherwise.
- B. Reinforcing Steel: Reinforcing steel, steel welded wire reinforcement (WWR), and dowels according to NJDOT Specifications, Section 905.01.

2.07 CONCRETE FINISHES

- A. See Section 033000 for additional requirements.
- B. Sidewalks and Dumpster Pads: Float and normal broom finish.
- C. Curbs and Gutters: Normal broom finish.

2.08 ACCESSORIES

- A. Expansion Joint Filler: NJDOT Specifications, Section 914.
- B. Curing Compound: Section 033000.

PART 3 - EXECUTION

3.01 PREPARATION

- A. Excavate and shape subgrade to line, grade, and cross section.
- B. Remove all soft subgrade material encountered while compacting and backfill with aggregate base.
- C. Moisten aggregate base or subgrade immediately before placing concrete to minimize absorption of water from fresh concrete.
- D. Provide concrete surfaces that are clean and dry - free of oil, dirt or foreign materials immediately before application of compounds or painting.

3.02 COMPACTION

- A. Refer to Section 312300 for additional compaction requirements.
- B. Subgrade: Compact as specified in Section 312300. Compact top 12 inches to 90 percent of maximum dry density, unless noted otherwise.
- C. Aggregate Base: Compact as specified in Section 312300. Compact to 90 percent of maximum dry density, unless noted otherwise.

3.03 CURB CONSTRUCTION

- A. According to NJDOT Specifications, Section 607.

3.04 SIDEWALK CONSTRUCTION

- A. According to NJDOT Specifications, Section 606.

3.05 FINISHING

- A. Float (for sidewalks and flatwork):
 1. Use magnesium or aluminum hand floats or power floats with slip on float shoes after concrete has stiffened to point where 1/4-inch maximum indentation can be imparted by normal foot pressure. Do not use combination blades for floating.

2. Float finish shall result in uniform smooth granular texture.
3. After floating, check slab tolerances with 10-foot straightedge. Fill low spots with fresh concrete.
4. Do not sprinkle with dry cement or add water.

B. Broom Finish:

1. Normal Broom Finish: Use fine, soft-bristled broom to produce a non-skid surface.
2. Sidewalks: Texture perpendicular to direction of travel with trowel and radius edge using 1/4-inch radius.
3. Curbs and Gutters: Texture parallel to travel direction of pavement.

3.06 TOLERANCES

A. Subgrade: Smooth and free from irregularities at the specified relative compaction. The subgrade shall be considered to extend over the full width of the base course.

1. Elevation: 1/2-inch, plus or minus from the indicated grade and cross-section.

B. Forms: Check constructed forms are within tolerance by using a 10-foot straightedge along the top of forms. Allowable tolerance is:

1. Grade: 1/8-inch over 10 feet (0.1 percent), plus or minus.
2. Alignment: 1/8-inch, plus or minus.

3.07 FIELD QUALITY CONTROL

A. Refer to Section 312300 for compaction and testing requirements.

B. Submit compaction test results to the Architect/Engineer for review.

C. Concrete Testing: Section 033000. Maintain records of placed concrete including: record date, location of pour, quantity, air temperature, and test samples taken. Submit test results to the Construction Manager for review.

D. Defective Concrete: As defined in Section 033000.

3.08 PROTECTION

A. Protect concrete from damage and replace if damage occurs.

3.09 CONTRACT CLOSEOUT

- A. Provide in accordance with Section 017700.

END OF SECTION 321600

SECTION 321710 - ASPHALT SIDEWALKS AND DRIVEWAYS

PART 1 - GENERAL

1.01 DESCRIPTION

- A. Provide asphalt curbs, gutters, and sidewalks as indicated and in compliance with Contract Documents.

1.02 PAYMENT

- A. All costs for Work required by this Section shall be included in the applicable unit price as set forth in Section 012901.

1.03 REFERENCES

- A. ASTM International (ASTM):
 - 1. D6690: Standard Specification for Joint and Crack Sealants, Hot Applied, for Concrete and Asphalt Pavements.
- B. NJDOT Specifications: New Jersey Department of Transportation (NJDOT) Standard Specifications for Road and Bridge Construction, 2019.

1.04 RELATED SECTIONS

- A. General Condition Article 4.7 – Shop Drawings and Other Submittals.
- B. Section 012901 – Measurement and Payment.
- C. Section 014300 - Quality Requirements.
- D. Section 016100 - Control of Materials.
- E. Section 017700 - Contract Closeout.
- F. Section 033000 - Cast-in-place Concrete.
- G. Section 312300 - Excavation and Fill.
- H. Section 321200 – Flexible Paving.

1.05 SUBMITTALS

- A. Submit the following in accordance with General Condition Article 4.7.

1.06 QUALITY ASSURANCE

- A. Comply with the requirements specified in Section 014300.
- B. Sustainability Standards Certifications.

1.07 DELIVERY STORAGE AND HANDLING

- A. Comply with the requirements specified in Section 016100.
- B. Transport bituminous mixtures in covered trucks,
 - 1. Suspend deliveries if;
 - a. It is raining or rain is imminent, or
 - b. Air temperature is less than 60 degrees F.
- C. Adjust weight, type, capacity, haul routes, and method of operation of hauling vehicles so that:
 - 1. No damage results to existing streets, subgrade or base course, and
 - 2. Noise and air pollution levels are not noticeably increased along selected haul route.
- D. Haul routes through residential areas shall be avoided.
- E. Submit haul route, procedures for transport, and schedule of operation times to the Construction Manager for acceptance.

1.08 PROJECT CONDITIONS

- A. Weather Limitations: Apply prime and tack coats when ambient temperature is above 50 degrees F, and when temperature has not been below 35 degrees F for 12 hours immediately prior to application. Do not apply when base is wet or contains an excess of moisture.
- B. Place asphalt concrete surface course when atmospheric temperature is above 40 degrees F, and when base is dry.

PART 2 - PRODUCTS

2.01 MATERIALS

- A. Aggregate Base: Minimum 4 inches thick, unless noted otherwise.

1. Dense-Graded Aggregate: NJDOT Specifications, Section 901.10. The Qualified Products List (QPL) can be found at <https://www.state.nj.us/transportation/eng/materials/qualified/QLDB.shtm>.

2.02 ASPHALT

- A. Asphalt: NJDOT Specifications, Section 902.02. Use Hot Mix Asphalt mixture 9.5M64.

2.03 ACCESSORIES

- A. Joint Materials: NJDOT Specifications, Section 914.

PART 3 - EXECUTION

3.01 PREPARATION

- A. Excavate and shape subgrade to line, grade, and cross section.
- B. Remove all soft subgrade material encountered while compacting and backfill with aggregate base.
- C. Provide asphalt surfaces that are clean and dry - free of oil, dirt or foreign materials immediately before application of compounds or painting.

3.02 COMPACTION

- A. Refer to Section 312300 for additional compaction requirements.
- B. Subgrade: Compact as specified in Section 312300. Compact top 12 inches to 90 percent of maximum dry density, unless noted otherwise.
- C. Aggregate Base: Compact as specified in Section 312300. Compact to 90 percent of maximum dry density, unless noted otherwise.
- D. Asphalt Surface: Compact as specified in NJDOT Specifications, Section 403.03.03.

3.03 SIDEWALK CONSTRUCTION

- A. According to NJDOT Specifications, Section 606.

3.04 TOLERANCES

- A. Subgrade: Smooth and free from irregularities at the specified relative compaction. The subgrade shall be considered to extend over the full width of the base course.
 1. Elevation: 1/2-inch, plus or minus from the indicated grade and cross-section.

- B. Forms: Allowable tolerance is:
 - 1. Grade: 1/8-inch over 10 feet (0.1 percent), plus or minus.
 - 2. Alignment: 1/8-inch, plus or minus.

3.05 FIELD QUALITY CONTROL

- A. Refer to Section 312300 for compaction and testing requirements.
- B. Submit compaction test results to Construction Manager for review.
- C. Asphalt Testing: Maintain records of placed asphalt including: record date, location of paving, quantity, air temperature, and core samples if taken. Submit samples to Construction Manager for review.

3.06 PROTECTION

- A. Protect asphalt from damage and replace if damage occurs.
- B. After final rolling:
 - 1. Do not permit pedestrian or vehicular traffic on pavement until it has cooled and hardened, and the surface temperature is less than 140 degrees F.
 - 2. Protect paving from traffic until mixture has cooled enough not to become marked.

3.07 CONTRACT CLOSEOUT

- A. Provide in accordance with Section 017700.

END OF SECTION 321710

SECTION 321726 - TACTILE WARNING SURFACING

PART 1 GENERAL

1.01 SUMMARY

A. Section Includes:

1. Cast-in-place detectable warning tiles.
2. Surface-applied detectable warning tiles.
3. Detectable warning mats.
4. Cast-in-place detectable warning metal tiles.
5. Surface-applied detectable warning metal tiles.
6. Detectable warning unit pavers.

1.02 PAYMENT

- A. No separate payment shall be made for performing any Work required under this Section. All costs for Work required by this Section shall be included in the applicable lump sum(s), as set forth in Section 012901.

1.03 RELATED SECTIONS

- A. General Conditions Article 4.7 – Shop Drawings and Other Submittals
- B. Section 012901 – Measurement and Payment
- C. Section 014300 – Quality Requirements
- D. Section 016100 – Control of Materials
- E. Section 017700 - Contract Closeout
- F. Section 321400 – Unit Paving
- G. Section 321600 - Concrete Curbs, Gutters, and Sidewalks

1.04 SUBMITTALS

- A. Submit the following items in accordance with General Conditions 4.7.

- B. Product Data: For each type of product.
- C. Samples for Initial Selection: For each type of exposed finish requiring color selection.
- D. Samples for Verification: For each type of tactile warning surface, in manufacturer's standard sizes unless otherwise indicated, showing edge condition, truncated-dome pattern, texture, color, and cross section; with fasteners and anchors.

1.05 CLOSEOUT SUBMITTALS

- A. Maintenance Data: For tactile warning surfacing, to include in maintenance manuals.

1.06 PROJECT CONDITIONS

- A. Cold-Weather Protection: Do not use frozen materials or materials mixed or coated with ice or frost. Do not build on frozen subgrade or setting beds. Remove and replace unit paver work damaged by frost or freezing.

- B. Weather Limitations for Adhesive Application:

- 1. Apply adhesive only when ambient temperature is above 50 deg F and when temperature has not been below 35 deg F for 12 hours immediately before application. Do not apply when substrate is wet or contains excess moisture.

- C. Weather Limitations for Mortar and Grout:

- 1. Cold-Weather Requirements: Comply with cold-weather construction requirements contained in ACI 530.1/ASCE 6/TMS 602.
- 2. Hot-Weather Requirements: Comply with hot-weather construction requirements contained in ACI 530.1/ASCE 6/TMS 602. Provide artificial shade and windbreaks, and use cooled materials as required. Do not apply mortar to substrates with temperatures of 100 deg F and higher.
 - a. When ambient temperature exceeds 100 deg F, or when wind velocity exceeds 8 mph and ambient temperature exceeds 90 deg F, set unit pavers within 1 minute of spreading setting-bed mortar.

1.07 WARRANTY

- A. Special Warranty: Manufacturer agrees to repair or replace components of tactile warning surfaces that fail in materials or workmanship within specified warranty period.

- 1. Failures include, but are not limited to, the following:

- a. Deterioration of finishes beyond normal weathering and wear.

- b. Separation or delamination of materials and components.
2. Warranty Period: Five years from date of Substantial Completion.

PART 2 PRODUCTS

2.01 DETECTABLE WARNING SURFACING, GENERAL

- A. Accessibility Requirements: Comply with applicable provisions in the U.S. Department of Justice's 2010 ADA Standards for Accessible Design for detectable warning surfaces.
 1. For detectable warning surfaces composed of multiple units, provide units that when installed provide consistent side-to-side and end-to-end dome spacing that complies with requirements.
- B. Source Limitations: Obtain each type of detectable warning surfacing from single source with resources to provide materials and products of consistent quality in appearance and physical properties.
- C. Color: Safety red according to FED-STD-595B color chip No. 31350.
- D. Detectable Warning Surface Shapes and Sizes:
 1. Rectangular panel, 24 by 48 inches, with 48 inches as the minimum width, width to match the curb ramp width.
 2. Radius panel, nominal 24 inches deep by with 48 inches as the minimum width along the outside radius.
 3. Or as shown on the Plans
- E. The detectable warning surface shall consist of a surface of truncated domes.
 1. Dome Spacing and Configuration: Domes shall be spaced in a square pattern, 1.6-inch minimum to 2.4-inch maximum, center-to-center. The minimum base to base spacing of the domes is 0.65 inch.
 2. Dome Size: Truncated domes in a detectable warning surface shall have a base diameter of 0.9 inch minimum and 1.4 inches maximum, a top diameter of 50 percent of the base diameter minimum to 65 percent of the base diameter maximum, and a height of 0.2 inch.

2.02 DETECTABLE WARNING TILES

- A. Cast-in-Place Detectable Warning Tiles: Accessible truncated-dome detectable warning tiles with replaceable surface configured for setting flush in new concrete walkway surfaces, with slip-resistant surface treatment on domes and field of tile.
1. Contractor to submit manufacturer and product for approval prior to installation.
 2. Material: Cast-fiber-reinforced polymer concrete tile or molded glass- and carbon-fiber-reinforced polyester.
 3. Mounting:
 - a. Permanently embedded detectable warning tile wet-set into freshly poured concrete.
 - b. Detectable warning tile set into formed recess in concrete and adhered with mortar.
 - c. Replaceable detectable warning tile wet-set into freshly poured concrete and surface-fastened to permanently embedded anchors.
- B. Surface-Applied Detectable Warning Tiles: Accessible truncated-dome detectable warning concrete tiles configured for surface application on existing concrete walkway surfaces, with slip-resistant surface treatment on domes, field of tile, and beveled outside edges.
1. Contractor to submit manufacturer and product for approval prior to installation.
 2. Material: Cast-fiber-reinforced polymer concrete tile or Molded glass- and carbon-fiber-reinforced polyester.
 3. Mounting: Adhered and/or fastened to existing concrete walkway.
- C. Cast-in-Place Detectable Warning Metal Tiles: Accessible truncated-dome detectable warning metal tiles with replaceable surface configured for setting flush in new concrete walkway surfaces, with slip-resistant surface treatment on domes and field of tile.
1. Contractor to submit manufacturer and product for approval prior to installation.
 2. Material:
 - a. Stainless-Steel Plate and Sheet: ASTM A 240/A 240M or ASTM A 666, Type 304 or Type 316L.
 - (1) Finish: Mill finish.

- b. Cast Iron: Gray iron, ASTM A 48/A 48M, CL 35.
- 3. Mounting:
 - a. Permanently embedded detectable warning tile wet-set into freshly poured concrete.
 - b. Permanently embedded detectable warning tile set into formed recess in concrete and adhered with mortar.
 - c. Replaceable embedded detectable warning tile fastened to permanently installed anchors.
- D. Surface-Applied Detectable Warning Metal Tiles: Accessible truncated-dome detectable warning metal tiles or plates configured for fastening to surface of existing concrete walkway surfaces, with slip-resistant surface treatment on domes, field of tile, and beveled outside edges.
 - 1. Contractor to submit manufacturer and product for approval prior to installation.
 - 2. Material: Stainless-Steel Plate and Sheet: ASTM A 240/A 240M or ASTM A 666, Type 304 or Type 316L.
 - 3. Finish: Mill finish.
 - 4. Mounting:
 - a. Replaceable surface-applied detectable warning tile fastened with permanently installed anchors to existing concrete walkway.
 - b. Permanently fixed detectable warning tile adhered and fastened to existing concrete walkway.

2.03 DETECTABLE WARNING MATS

- A. Surface-Applied Detectable Warning Mats: Accessible truncated-dome detectable warning resilient mats, UV resistant, manufactured for adhering to existing concrete walkway surfaces, with slip-resistant surface treatment on domes, field of mat, and beveled outside edges.
 - 1. The Contractor to submit manufacturer and product for approval prior to installation.
 - 2. Material: Modified rubber compound, UV resistant.
 - 3. Mounting: Adhered to pavement surface with adhesive and fastened with fasteners.

2.04 DETECTABLE WARNING UNIT PAVERS

- A. Detectable Warning Concrete Unit Pavers: Solid paving units, made from normal-weight concrete with a compressive strength of not less than 5000 psi, water absorption of not more than 5 percent according to ASTM C 140, and no breakage and not more than 1 percent mass loss when tested for freeze-thaw resistance according to ASTM C 67, with accessible detectable warning truncated domes on exposed surface of units.
1. Contractor to submit manufacturer and product for approval prior to installation, detectable warning unit pavers to match existing pavers in size and shape.
 2. Shapes and Sizes:
 - a. Thickness: Match existing at field of tile.
 - b. Face Size: Nominal Match existing at field of tile.
 3. Dome Spacing and Configuration: See Section 2.01.
 4. Color: See Section 2.01.
- B. Setting Bed: Comply with requirements in Section 321400.
- C. Aggregate Setting Bed:
1. Graded Aggregate for Base: Sound, crushed stone or gravel complying with ASTM D 448 for Size No. 8.
 2. Sand for Leveling Course: Sound, sharp, washed, natural sand or crushed stone complying with gradation requirements in ASTM C 33/C 33M for fine aggregate.
 3. Sand for Joints: Fine, sharp, washed, natural sand or crushed stone with 100 percent passing No. 16 sieve and no more than 10 percent passing No. 200 sieve.
- D. Mortar Setting Bed:
1. Portland Cement: ASTM C 150/C 150M, Type I or Type II.
 2. Sand: ASTM C 33/C 33M.
 3. Latex Additive: Manufacturer's standard water emulsion, serving as replacement for part or all of gaging water, of type specifically recommended by latex-additive manufacturer for use with field-mixed Portland cement and aggregate mortar bed, and not containing a retarder.
 4. Thinset Mortar: Latex-modified Portland cement mortar complying with ANSI A118.4.

5. Water: Potable.

2.05 ACCESSORIES

- A. Fasteners and Anchors: Manufacturer's standard as required for secure anchorage of tactile warning surfaces, noncorrosive and compatible with each material joined, and complying with the following:
 - 1. Furnish Type 304 or Type 316 stainless-steel fasteners for exterior use.
 - 2. Fastener Heads: For nonstructural connections, use flathead or oval countersunk screws and bolts with tamper-resistant heads, colored to match tile.
- B. Adhesive: As recommended by manufacturer for adhering tactile warning surfacing unit to pavement.
- C. Sealant: As recommended by manufacturer for sealing perimeter of tactile warning surfacing unit.

PART 3 EXECUTION

3.01 EXAMINATION

- A. Verify that pavement is in suitable condition to begin installation according to manufacturer's written instructions. Verify that installation of tactile warning surfacing will comply with accessibility requirements upon completion.
- B. Proceed with installation only after unsatisfactory conditions have been corrected.

3.02 INSTALLATION OF TACTILE WARNING SURFACING

- A. General: Prepare substrate and install tactile warning surfacing according to manufacturer's written instructions unless otherwise indicated.
- B. Place tactile warning surfacing units in dimensions and orientation indicated. Comply with location requirements of AASHTO MP 12.

3.03 INSTALLATION OF DETECTABLE WARNING TILES

- A. Cast-in-Place Detectable Warning Tiles:
 - 1. Concrete Paving Installation: Comply with installation requirements in Section 321600. Mix, place, and finish concrete to conditions complying with detectable warning tile manufacturer's written requirements for satisfactory embedment of tile.

2. Set each detectable warning tile accurately and firmly in place and completely seat tile back and embedments in wet concrete by tamping or vibrating. If necessary, temporarily apply weight to tiles to ensure full contact with concrete.
3. Set surface of tile flush with surrounding concrete and adjacent tiles, with variations between tiles and between concrete and tiles not exceeding plus or minus 1/8 inch from flush.
4. Protect exposed surfaces of installed tiles from contact with wet concrete. Complete finishing of concrete paving surrounding tiles. Remove concrete from tile surfaces.
5. Clean tiles using methods recommended in writing by manufacturer.

B. Removable Cast-in-Place Detectable Warning Tiles:

1. Concrete Paving Installation: Comply with installation requirements in Section 321600. Mix, place, and finish concrete to conditions complying with detectable warning tile manufacturer's written requirements for satisfactory embedment of removable tile.
2. Set each detectable warning tile accurately and firmly in place with embedding anchors and fasteners attached, and firmly seat tile back in wet concrete by tamping or vibrating. If necessary, temporarily apply weight to tiles to ensure full contact with concrete.
3. Set surface of tile flush with surrounding concrete and adjacent tiles, with variations between tiles and between concrete and tiles not exceeding plus or minus 1/8 inch from flush.
4. Protect exposed surfaces of installed tiles from contact with wet concrete. Complete finishing of concrete paving surrounding tiles. Remove concrete from tile surfaces.
5. Clean tiles using methods recommended in writing by manufacturer.

C. Surface-Applied Detectable Warning Tiles:

1. Lay out detectable warning tiles as indicated and mark concrete pavement.
2. Prepare existing paving surface by grinding and cleaning as recommended by manufacturer.
 - a. Cut perimeter kerf in existing concrete pavement to receive metal tile flange.
3. Apply adhesive to back of tiles in amounts and pattern recommended by manufacturer, and set tiles in place. Firmly seat tiles in adhesive bed, eliminating

air pockets and establishing full adhesion to pavement. If necessary, temporarily apply weight to tiles to ensure full contact with concrete.

4. Install anchor devices through face of tiles and into pavement using anchors located as recommended by manufacturer. Set heads of anchors flush with top surface of mat.
5. Mask perimeter of tiles and adjacent concrete, and apply sealant in continuous bead around perimeter of tile installation.
6. Remove masking, adhesive, excess sealant, and soil from exposed surfaces of detectable warning tiles and surrounding concrete pavement using cleaning agents recommended in writing by manufacturer.
7. Protect installed tiles from traffic until adhesive has set.

3.04 INSTALLATION OF DETECTABLE WARNING MATS

- A. Lay out detectable warning mats as indicated and mark concrete pavement at edges of mats.
- B. Prepare existing paving surface by grinding and cleaning as recommended by manufacturer.
- C. Apply adhesive to back of mat in amounts and pattern recommended by manufacturer, and set mat in place. Firmly seat mat in adhesive bed, eliminating air pockets and establishing full adhesion to pavement. If necessary, temporarily apply weight to mat to ensure full contact with adhesive.
- D. Install anchor devices through face of mat and into pavement using anchors located as recommended by manufacturer. Set heads of anchors flush with mat surface.
- E. Mask mat perimeter and adjacent concrete, and apply sealant in continuous bead around perimeter of mat.
- F. Remove masking, adhesive, excess sealant, and soil from exposed surfaces of detectable warning mat and surrounding concrete pavement using cleaning agents recommended in writing by manufacturer.
- G. Protect installed mat from traffic until adhesive has set.

3.05 INSTALLATION OF DETECTABLE WARNING UNIT PAVERS

- A. Unit Paver Installation, General:
 1. Setting-Bed and Unit Paver Installation: Comply with installation requirements in Section 321400.

2. Mix unit pavers from several pallets or cubes, as they are placed, to produce uniform blend of colors and textures.
3. Cut unit pavers with motor-driven masonry saw equipment to provide pattern indicated and to fit adjoining work neatly. Use full units without cutting where possible.
4. Tolerances: Do not exceed 1/4 inch in 10 feet from level, or indicated slope, for finished surface of paving.

B. Aggregate Setting-Bed Applications:

1. Place aggregate base compact by tamping with plate vibrator, and screed to depth indicated.
2. Place leveling course and screed to a thickness of 1 to 1-1/2 inches, taking care that moisture content remains constant and density is loose and uniform until unit pavers are set and compacted.
3. Treat leveling course with herbicide to inhibit growth of grass and weeds.
4. Set unit pavers with a minimum joint width of 1/16 inch and a maximum of 1/8 inch, being careful not to disturb leveling base. If pavers have spacer bars, place pavers hand tight against spacer bars. Use string lines to keep straight lines.
5. Vibrate pavers into leveling course with a low-amplitude plate vibrator capable of a 3500- to 5000-lbf compaction force at 80 to 90 Hz.
6. Spread dry sand and fill joints immediately after vibrating pavers into leveling course. Vibrate pavers and add sand until joints are completely filled, then remove excess sand. Leave a slight surplus of sand on the surface for joint filling.

C. Mortar Setting-Bed Applications:

1. Saturate concrete subbase with clean water several hours before placing setting bed. Remove surface water about one hour before placing setting bed.
2. Apply mortar-bed bond coat over surface of concrete subbase about 15 minutes before placing mortar bed. Limit area of bond coat to avoid its drying out before placing setting bed. Do not exceed 1/16-inch thickness for bond coat.
3. Apply mortar bed over bond coat; spread and screed mortar bed to uniform thickness at subgrade elevations required for accurate setting of pavers to finished grades indicated.

4. Mix and place only that amount of mortar bed that can be covered with pavers before initial set. Before placing pavers, cut back, bevel edge, and remove and discard setting-bed material that has reached initial set.
5. Place pavers before initial set of cement occurs. Immediately before placing pavers on mortar bed, apply uniform 1/16-inch- thick bond coat to mortar bed or to back of each paver with a flat trowel.
6. Tamp or beat pavers with a wooden block or rubber mallet to obtain full contact with setting bed and to bring finished surfaces within indicated tolerances. Set each paver in a single operation before initial set of mortar; do not return to areas already set or disturb pavers for purposes of realigning finished surfaces or adjusting joints.
7. Spaced Joint Widths: Provide 3/8-inch nominal joint width with variations not exceeding plus or minus 1/16 inch.
8. Grouted Joints: Grout paver joints complying with ANSI A108.10. Grout joints as soon as possible after initial set of setting bed.
 - a. Force grout into joints, taking care not to smear grout on adjoining surfaces.
 - b. Tool exposed joints slightly concave when thumbprint hard.
 - c. Cure grout by maintaining in a damp condition for seven days unless otherwise recommended by grout or liquid-latex manufacturer.
9. Remove excess grout from exposed paver surfaces; wash and scrub clean.
10. Protect installation from traffic until grout has set.

3.06 CLEANING AND PROTECTION

- A. Remove and replace tactile warning surfacing that is broken or damaged or does not comply with requirements in this Section. Remove in complete sections from joint to joint unless otherwise approved by Engineer. Replace using tactile warning surfacing installation methods acceptable to Engineer.
- B. Protect tactile warning surfacing from damage and maintain free of stains, discoloration, dirt, and other foreign material.

3.07 CONTRACT CLOSEOUT

- A. Refer to Section 017700

END OF SECTION 321726

NO TEXT ON THIS PAGE

SECTION 321813 – ARTIFICIAL TURF

PART 1 - GENERAL

1.01 DESCRIPTION

A. Section Includes:

1. The extent of artificial turf work is shown on the Contract Drawings.
2. Installation work includes:
 - a. Verifying subgrade elevations and slope generally conform to the lines, grades, infiltration rate, density, and site conditions depicted in the Contract Drawings.
 - b. Furnishing and installing geotextile and/or geomembrane liner (where required), horizontal drainage piping (where required), base course, edge restraint, plastic lumber nailer boards, artificial turf material, and resilient infill system in general conformance to the lines and grades shown on the Contract Drawings.

1.02 PAYMENT

- ##### A. No separate payment shall be made for performing any Work required under this Section. All costs for Work required by this Section shall be included in the applicable lump sum, unit price(s), or allowance(s) as set forth in Section 012901.

1.03 REFERENCES

A. American Society for Testing and Materials (ASTM):

1. ASTM D792 Specific Gravity
2. ASTM D1335 Tuft Bind
3. ASTM C5034 Grab Breaking Strength
4. ASTM F1551 Water Permeability
5. ASTM F1951 Accessibility of Surface Systems Under and Around Playground Equipment

1.04 RELATED SECTIONS

- ##### A. General Conditions Article 4.7 – Shop Drawings and Other Submittals.

- B. Section 012901 – Measurement and Payment.
- C. Section 014300 - Quality Requirements.
- D. Section 016100 – Control of Materials.
- E. Section 017423 – Cleaning Up.
- F. Section 017700 - Contract Closeout.
- G. Section 312200 – Grading.
- H. Section 312300 – Excavation and Fill.
- I. Section 321816 – Playground Protective Surfacing.

1.05 SUBMITTALS

- A. Submit the following in accordance with General Conditions Article 4.7.
 - 1. Product Data: For each type of product indicated.
 - 2. Shop Drawings: For each artificial turf surface system, include materials, plans, cross sections, drainage, installation, penetration details, and edge termination.
 - 3. Samples for Initial Selection: For each type of artificial turf surface system indicated.
 - 4. Include similar Samples of artificial turf surface system and accessories involving color selection.
 - 5. Samples for Verification: Contractor shall submit to the Architect/Engineer for approval a minimum of two samples of each artificial turf type/size/thickness/color/finish specified. The samples shall represent the range of shape, texture, and color permitted for the respective type. Color(s) will be selected by Landscape Architect and Construction Manager. For each type of artificial turf surface system indicated.
 - a. Minimum 9-by-9-inch (229-by-229-mm) Sample of synthetic artificial turf seamless surface.

1.06 QUALITY ASSURANCE

- A. Comply with the requirements of Section 014300.

- B. Qualifications: A Company having no less than 5 years' experience (not as an individual), or current IPEMA certification for the scope and scale of the work described in this Section.
- C. Materials and workmanship: the installation crew shall maintain a log of workman on site, weather conditions, official visitors to the site, and product used by quality control numbers noted on the packaging.
- D. Standards and Guidelines: Comply with CPSC No. 325, "Handbook for Public Playground Safety"; ASTM F 1292; and ASTM F 1487.
- E. Mockups: Build mockups to verify selections made under submittals, to demonstrate aesthetic effects, and to set quality standards for materials and execution.
 - 1. General:
 - a. Do not proceed with work until the mock-up has been reviewed and accepted by Construction Manager and Landscape Architect.
 - b. Provide a mock-up of each type, pattern, and installation per method for approval.
 - c. Mock-up located within the finish work of construction is not allowed unless approved by Construction Manager.
 - d. Prior to developing a mock-up contractor to submit drawings depicting the layout of the mock-up for approval.
 - e. Accepted mock-up area may remain on site and shall be the standard for performance of the installation.
 - f. Coordinate with mock-up requirements of other sections for interface with items such as and not limited to concrete paving, playground protective surfacing, raised curbs, flush curbs, wall type 2 with metal cladding, pedestrian bridge columns, area drains, irrigation components, concrete floodwall and footing slabs.
 - g. All Mock-ups are subject to final approval. If rejected contractor to provide additional mock-ups at no additional cost. If any specific aspect of a mock-up is not conforming to the approved mock-up drawing layout, the Contractor to fix or redo the submittal at no additional cost.
 - 2. Preliminary Mock-up for Color and Finish Verification of product to be used in the final mockup: Construct a preliminary mockup field 48 inch by 48 inch of the artificial turf on aggregate base system demonstrating the product color, finish, and blade height of each selected artificial turf product.

- a. Provide one mockup for each type of artificial turf identified in the Contract Documents for approval by the Landscape Architect.
 - b. Retain approved preliminary mock-up sample for comparison to final mockup.
3. Final Mock-up: Install one 10 ft x 10 ft artificial turf area for each artificial turf type following the installation practices described in Article 3.02. This area shall be used to verify lines; laying pattern(s); color(s); adjacencies; edge conditions; and, texture of the job.
- a. Mockup types to include:
 - 1) Off-site installation: An area that is constructed outside of the field of work and to be protected throughout the project. The mock-up to demonstrate the full interface of all edging with artificial turf including at flush concrete curb, at raised concrete curb, at concrete wall, at wall type 1 with metal cladding, at pedestrian bridge column, at drain cover, and at playground protective surfacing. The mock-up to also demonstrate the full array of plan geometries and proper installation techniques of artificial turf including curved plan geometries representative of the edge conditions as shown in the Contract Drawings. This mock-up once approved it shall be the standard from which the work will be judged.
 - 2) First in place: These are locations in the site to verify that installation is in conformance to the approved Off-site mockup. Mock-up may be retained as a part of the finished work upon approval by Landscape Architect and the Construction Manager. If mock-up is not retained, remove and dispose of mock-up prior to the completion of the project.
4. All mockups are subject to approval by Landscape Architect and the Construction Manager.

1.07 DELIVERY, STORAGE, AND HANDLING

- A. Conform with the requirements of Section 016100.
- B. Contractor shall coordinate delivery and install schedule to minimize interference with normal use of buildings and/or waterfront walkway pedestrian access adjacent to artificial turf installation areas.
- C. Contractor shall check all materials upon delivery to assure that the proper materials have been received and are in good condition before signing off on the manufacturer's packing slip.

- D. Contractor shall protect all materials from damage or contamination due to job site conditions and in accordance with manufacturer's recommendations. Damaged or contaminated materials shall not be incorporated into the work.
- E. Contractor shall handle and transport aggregates to avoid segregation, contamination, and degradation and keep different materials sufficiently separated as to prevent mixing. The material shall not be dumped or stored one material on top of another unless it is part of the installation process. Materials shall be covered to prevent removal by wind.
- F. Geosynthetics shall be delivered, stored and handled in accordance with ASTM D4873.

1.08 ENVIRONMENTAL CONDITIONS

- A. Weather Limitations: Proceed with installation only when existing and forecasted weather conditions permit artificial turf surface system installation to be performed according to manufacturers' written instructions and warranty requirements.

PART 2 - PRODUCTS

2.01 MANUFACTURER

- A. ForeverLawn – Basis of Design
 - 1. 8007 Beeson St. Louisville, OH 44641; Telephone: 866-992-7876; Fax: 330-249-2170; Web: www.foreverlawn.com
- B. SynLawn
 - 1. 145 River Road, Montville, NJ 07045; Telephone: 973-796-7166; Web: www.synlawn.com
- C. Progreen Synthetic Turf Systems
 - 1. 146 Fairchild Street, Suite 150, Daniel Island, SC 29492; Telephone: 855-464-8873; Web: www.progreen.com
- D. Or approved equal.

2.02 ARTIFICIAL TURF

- A. Products
 - 1. “K9 Grass Classic” or approved equal.
 - a. Yarn Type:

- 1) Primary: Polyethylene monofilament.
 - 2) Secondary: Heat set textured nylon monofilament.
 - b. Yarn Color:
 - 1) Primary: Summer green.
 - 2) Secondary: Turf green.
 - c. Yarn Count:
 - 1) Primary: 5000/4.
 - 2) Secondary: 4200/8.
 - d. Tufting Construction: Knitted.
 - e. Blade Height: 7/8 inches.
 - f. Face Weight: 72 ounces.
 - g. Product Weight: 80 ounces.
 - h. Backing: Flow-Through Backing.
 - i. Seaming: Turf adhesive.
 - j. Infill: None.
2. “Select VR” or approved equal.
- a. Yarn Type:
 - 1) Primary: Polyethylene monofilament.
 - 2) Secondary: Heat set textured nylon monofilament.
 - b. Yarn Color:
 - 1) Primary: Field green.
 - 2) Secondary: Turf green.
 - c. Yarn Count:
 - 1) Primary: 10,800/6.

- 2) Secondary: 5,040/12.
- d. Tufting Construction: Dual yarn, same row.
- e. Blade Height: 2 inches.
- f. Face Weight: 70 ounces.
- g. Product Weight: 135 ounces.
- h. Backing:
 - 1) Primary: 18 pic reinforced tri-component.
 - 2) Secondary: 50 oz. polyurethane with 6 oz. non-woven geotex laminate.
- i. Seaming: Micromechanical bonding.
- j. Infill: .75 pounds of rubber (or sand/rubber mix)

2.03 BASE COURSE

- A. Permeable Aggregate Base Course: Section 312300
- B. Geotextile Fabric: Section 312300
- C. Choker Course: Section 312300
- D. Storage Gravel: Section 312300

2.04 MOUNTING SYSTEM

- A. Plastic Lumber Nailer Boards:
 - 1. As per the Contract Documents and manufacturer's recommendations.
- B. Fasteners:
 - 1. As per the Contract Documents and manufacturer's recommendations.

PART 3 - EXECUTION

3.01 EXAMINATION

- A. Installation of the synthetic turf system is to comply with the manufacturer's recommendations, requirements and the reviewed and approved shop drawings.

- B. Perform all work in strict accordance with the Contract Documents and the manufacturers specifications and instructions. Only those skilled technicians proposed in the bid phase are to be assigned to this project by the Contractor.
- C. The designed Supervisor for the Synthetic Turf Installer must be present during any and all construction activity associated with the synthetic turf installation, including testing, cleanup and training.
- D. All products and equipment are to be from the sources approved by the authorized turf manufacturer and conform to the specifications.

3.02 INSTALLATION

- A. Confirm sub-base conditions and grading allow for the installation of artificial turf in accordance with the manufacturer's recommendations and finish grade elevations as shown on the Contract Documents.
 - 1. For base course, refer to Section 312300.
 - a. Install Storage Gravel in accordance with Section 312300
 - b. Install Choker Course in accordance with Section 312300
 - c. Install Geotextile Fabric in accordance with Section 312300
 - d. Install Permeable Aggregate Base Course in accordance with Section 312300
 - 2. For grading, refer to Section 312200.
- B. Install synthetic turf system in accordance with the manufacturer's written installation instructions.
- C. All inlaid areas shall have full fastenings and no loose areas. At no time can pulling on a section separate the materials.
- D. Turf shall be attached to the perimeter edge as shown in the Contract Drawings and as per the manufacturer.
- E. Turf shall be attached at transitions to playground protective surfacing as shown in the Contract Drawings as per the manufacturer.
 - 1. For playground protective surfacing, refer to Section 321816.
- F. All seams and inlaid areas shall be brushed thoroughly before infill materials are installed.
- G. All terminations shall be as detailed and approved in the shop drawings.

3.03 CLEAN UP

- A. Comply with Section 017423.

3.04 CONTRACT CLOSEOUT

- A. Comply with Section 017700.

END OF SECTION 321813

NO TEXT ON THIS PAGE

SECTION 321816 – PLAYGROUND PROTECTIVE SURFACING

PART 1 - GENERAL

1.01 DESCRIPTION

- A. Provide a two (2)-layer playground protective surfacing system as indicated and in compliance with Contract Documents.
 - 1. Unitary synthetic poured rubber seamless surface

1.02 PAYMENT

- A. No separate payment shall be made for performing any Work required under this Section. All costs for Work required by this Section shall be included in the Cove Park lump sum as set forth in Section 012901.

1.03 REFERENCES

- A. American Society for Testing and Materials (ASTM):
 - 1. ASTM D412 Standard Test Methods for Vulcanized Rubber and Thermoplastic Rubbers and Thermoplastic Elastomers-Tension.
 - 2. ASTM D624 Standard Test Method for Tear Strength of Conventional Vulcanized Rubber and Thermoplastic Elastomers.
 - 3. ASTM D2047 Standard Test Method for Static Coefficient of Friction of Polish-Coated Floor Surfaces as Measured by the James Machine.
 - 4. ASTM D2859 Standard Test Method for Flammability of Finished Textile Floor Covering Materials.
 - 5. ASTM E303 Standard Test Method for Measuring Surface Frictional Properties Using the British Pendulum Tester.
 - 6. ASTM F355 Standard Test Method for Impact Attenuation of Play Surface Systems, Other Protective Sport Systems, and Materials Used for Athletics, Recreation and Play.
 - 7. ASTM F1292 Standard Specification for Impact Attenuation of Surface Systems Under and Around Playground Equipment.

8. ASTM F1951 Standard Specification for Determination of Accessibility of Surface Systems Under and Around Playground Equipment.
9. ASTM F2223 Standard Guide for ASTM Standards on Playground Surfacing.
10. ASTM F2479 Guide for Specification, Purchase, Installation and Maintenance of Poured-In-Place Playground Surfacing.
11. ASTM F3313 Test Method for Determining Impact Attenuation of Playground Surfaces Within the Use Zone of Playground Equipment as Tested in the Field.

1.04 RELATED SECTIONS

- A. General Conditions Article 4.7 – Shop Drawings and Other Submittals.
- B. Section 012901 – Measurement and Payment.
- C. Section 014300 - Quality Requirements.
- D. Section 017423 – Cleaning Up.
- E. Section 017700 - Contract Closeout.
- F. Section 116800 – Play Field Equipment and Structures.
- G. Section 312300 – Excavation and Fill
- H. Section 321813 – Artificial Turf

1.05 DEFINITIONS

- A. Critical Height: Standard measure of shock attenuation. According to CPSC No. 325, this means "the fall height below which a life-threatening head injury would not be expected to occur."
- B. SBR: Styrene-butadiene rubber.
- C. Unitary Surface – A two (2) layer Poured in Place surfacing system that is mixed and installed on site to form a unitary, resilient surface to reduce the severity of head injuries because of falls from playground equipment.

1.06 PERFORMANCE REQUIREMENTS

- A. Impact Attenuation: According to ASTM F 1292.
- B. Accessibility of Surface Systems: According to ASTM F 1951.

1.07 SUBMITTALS

- A. Submit the following in accordance with General Conditions Article 4.7.
 - 1. Product Data: For each type of product indicated.
 - 2. Shop Drawings: For each playground surface system, include materials, plans, cross sections, drainage, installation, penetration details, and edge termination. Include patterns made by varying colors of surfacing.
 - 3. Samples for Initial Selection: For each type and each color of playground surface system indicated.
 - 4. Include similar Samples of playground surface system and accessories involving color selection.
 - 5. Samples for Verification: For each type and each color of playground surface system indicated.
 - a. Minimum 9-by-9-inch (229-by-229-mm) Sample of synthetic rubber seamless surface.
 - 6. Product Schedule: For playground surface systems.
 - 7. Solar reflectance data.
- B. Coordination Drawings: Plans, drawn to scale, on which the following items are shown and coordinated with each other, using input from Installers of the items involved:
 - 1. Extent of surface systems and use zones for equipment.
 - 2. Critical heights for playground surfaces and fall heights for equipment.
- C. Material Certificates: SDS and Technical Data sheets: From a single supply source, for each of the following components, signed by manufacturers:
 - 1. SBR Recycled rubber
 - 2. EPDM Colored Rubber

3. EPDM Black Recycled Rubber
 4. Polyurethane Binder
- D. Material Test Reports: For the following, from a qualified testing agency, indicating compliance with requirements:
1. ASTM 1292-13 or latest revision, with results showing safety compliance for a fall from the play equipment of a g-force of less than 200 and a HIC of less than 1000, when tested to the required temperatures and conditions of the ASTM standard.
 2. ASTM D-2859- latest revision Flammability rating to “PASS”
 3. ASTM E-303- latest revision Coefficient of Friction to be no less than 70 wet and 90 dry.
 4. Independent Laboratory test showing that all components are free of phthalates, polycyclic hydrocarbons, (PAH), lead and other heavy metals identified by the CPSC for use around children.
 5. IPEMA certification of “Pass” of the surface thickness for all respective Critical Fall Heights of the proposed equipment.
- E. Field quality-control reports.
- F. Warranty: Sample of special warranty.
- G. Maintenance Data: For playground surface system to include in maintenance manuals.
- H. Furnish extra materials that match products installed and that are packaged with protective covering for storage and identified with labels describing contents.
- 1.08 QUALITY ASSURANCE
- A. In accordance with Section 014300.
 - B. Qualifications: A Company having no less than 5 years’ experience (not as an individual), or current IPEMA certification for the scope and scale of the work described in this Section.
 - C. All materials shall be single sourced from a current ISO 9001 certified manufacturer.

- D. Materials and workmanship: the installation crew shall maintain a log of workman on site, weather conditions, official visitors to the site, and product used by quality control numbers noted on the packaging.
- E. Testing Agency Qualifications: If follow up testing is required, an independent testing laboratory with no less than 5 years' experience with ASTM 1292, acceptable to authorities. Any post construction testing shall be made from the actual deck height or other feature of the equipment with a CFH. The cost of follow up testing is not included unless specifically requested by the Owner and as an additional service. Retain first paragraph below if unitary synthetic rubber seamless system is specified.
- F. Standards and Guidelines: Comply with CPSC No. 325, "Handbook for Public Playground Safety"; ASTM F 355; ASTM F 1292; ASTM F 2223; ASTM F 2479 and ASTM F 3313.
- G. Mock-ups: Build mockups to verify selections made under submittals, to demonstrate aesthetic effects, and to set quality standards for materials and execution.
 - 1. General:
 - a. Do not proceed with work until the mock-up has been reviewed and accepted by Construction Manager.
 - b. Provide a mock-up of each type, pattern, and installation per method for approval.
 - c. Mock-up located within the finish work of construction is not allowed unless approved by Construction Manager.
 - d. Prior to developing a mock-up contractor to submit drawings depicting the layout of the mock-up for approval.
 - e. Accepted mock-up area may remain on site and shall be the standard for performance of the installation.
 - f. Coordinate with Mock-up requirements of other sections for interface with items such as and not limited to concrete paving, unit paving, tree pits, planting, light poles, and walls.
 - g. All Mock-ups are subject to final approval. If rejected contractor to provide additional mock-ups at no additional cost. If any specific aspect of a mock-up is not conforming to the approved mock-up drawing layout, the Contractor to fix or redo the submittal at no additional cost.

2. Preliminary Mock-up for Color and Finish Verification of product to be used in the final mock-up: Construct a preliminary mock-up field 48 inch by 48 inch of the full depth playground protective surfacing over aggregate base system demonstrating the range of safety surface colors identified in the Contract Drawings.
 - a. Provide two preliminary mockups for color and finish selection and approval by the Landscape Architect.
 - b. Retain approved preliminary mock-up sample for comparison to final mock-up.
 3. Final Mock-up: Install three (3) 10 ft x 10 ft protective surfacing areas following the installation practices described in Article 3.02 to 3.03. This area shall be used to verify lines; laying pattern(s); color(s); adjacencies; edge conditions; and, texture of the job.
 - a. To provide a proper representation of color blends and patterning, installation of sample mock-up will include a portion of each protective surfacing color zone.
 - b. Mockup types to include:
 - (1) Off-site installation: An area that is constructed outside of the field of work and to be protected throughout the project. The mockup to demonstrate the layout of the protective surfacing as shown on the Contract Drawings and full interface of edge conditions for protective surfacing including at flush concrete curb, at artificial turf – play, at flush curb with decking, and at wall type 1 with metal cladding. This mockup once approved it shall be the standard from which the work will be judged.
 - (2) First in place: These are locations in the site to verify that installation is in conformance to the approved Off-site mockup. Mock-up may be retained as a part of the finished work upon approval by Landscape Architect and the Construction Manager. If mock-up is not retained, remove and dispose of mock-up prior to the completion of the project.
 4. All mock-ups are subject to approval by Landscape Architect and the Construction Manager.
- H. All installed protective surfacing and equipment required to meet applicable safety and other inspection criteria. For playground equipment, comply with requirements in Section 116800. Contractor to confirm certification of playground construction by a

certified playground equipment inspector upon completion of playground and protective surfacing installation.

- I. Transition to other material types per the manufacturer’s recommendations, Construction Drawings, and per the approved mock-ups. For artificial turf, comply with requirements in Section 321813.
- J. Before commencing installation at the site, conduct a pre-construction conference to be attended by the Contractor, Protective Surfacing Installer, Protective Surfacing Supplier, Landscape Architect, and Construction Manager. Review the field-constructed mock-ups, availability of materials, schedules, construction sequencing, procedures and other matters relating to the protective surfacing installation. Proceed after all questions regarding the work have been resolved.

1.09 PROJECT CONDITIONS

- A. Weather Limitations: Proceed with installation only when existing and forecasted weather conditions permit playground surface system installation to be performed according to manufacturers' written instructions and warranty requirements.
 - 1. Minimum ambient temperature is 40 degrees F (1 degree C) and maximum ambient temperature is 90 degrees F (32 degrees C). Do not install in steady or heavy rain.

1.10 WARRANTY

- A. Special Warranty: Manufacturer's standard form in which manufacturer agrees to repair or replace components of playground surface system that fail in materials or workmanship within specified warranty period of 10 years.
 - 1. Failures include, but are not limited to, the following:
 - a. Reduction in impact attenuation.
 - b. Deterioration of surface and other materials beyond normal weathering.
- B. Provide a written Maintenance Instruction Statement to the Construction Manager. The surface shall be protected after installation and the Warranty shall begin upon Project Substantial Completion. The Contractor is responsible to protect the surface from damage until Project is accepted by the DEP. Damage caused by foot traffic or use during the cure period is not covered by the Warranty. Upon completion, provide the site-specific Warranty to the City of Hoboken.

PART 2 - PRODUCTS

2.01 MANUFACTURER

A. Material as supplied by one of the following:

1. USSA

- a. 9 Sounds View Court, Suite 2A, Greenwich, CT 06830. Telephone: 203-869-1741; Web: www.sustainablesurfacing.com

2. Surface America, Inc.

- a. PO Box 157 Williamsville, NY 14231. Telephone: 716-632-8413; Fax: 716-632-8324; Email: info@surfaceamerica.com ; Web: www.surfaceamerica.com

3. Game Time

- a. 150 Playcore Drive SE Fort Payne, Alabama 35967. Telephone: 800-235-2440; Web: www.gametime.com/playground-surfacing/

2.02 PLAYGROUND SAFETY SURFACING

A. The depth and thickness of the system shall meet the CPSC requirements for safety of the equipment and area shown on the drawings. In all cases, the EPDM top wearing course shall be ½ inch thick and the cushion course shall be as required to achieve the ASTM 1292 safety requirements. The components of the finished product shall be provided from one supply source and include the following:

1. Cushion course: Recycled SBR rubber buffings and granulate derived from car and or truck tires that have been cleaned of extraneous metals and other deleterious materials, graded and uniformly packaged. Size 6/16 mesh- nominal 3/8” strands and 5/18 mesh and nominal 7-15mm rough cut granules. Nylon strand fiber content is acceptable in the rough-cut granules.

- a. Thickness: Cushion course thickness shall be determined by critical fall heights of playground equipment and per safety surface manufacturer recommendations for the critical fall heights of play equipment.

2. Top wearing course: EPDM Rubber- granulated, Sulphur cured synthetic rubber with UV stabilizers, size 1-3.5mm and no greater than 2 percent dust. Density 1.6 g/cm³; Shore A 60 (+/- 5); tensile strength > 6MPa; Elongation at break > 700.

Color coated SBR, PVC, TPV, or vinyl granules are not acceptable. Color EPDM shall be as stated on the Contract Drawings.

3. Polyurethane Binders- shall be polyurethanes, one part moisture cured, with 0.00g/l VOC specifically formulated for bonding of rubber particles. Binder shall exhibit high strength and elongation with UV stabilizers and radical scavengers. The compressed, aromatic PU bound EPDM mat shall exhibit tensile strength of >150 PSI and 100 percent elongation after 10 days' water submersion at 90 degrees F. If the Aliphatic PU is specified for the EPDM wearing course, the mat shall exhibit tensile strength of >150 psi and 200 percent elongation. Provide catalyzed or non-catalyzed binder types as recommended by the manufacturer, based on prevailing weather
 - a) Aromatic Polyurethane Binders for the SBR cushion course shall be used in the base SBR cushion course and the top EPDM Wearing Course Aliphatic is additionally specified for the top course.

2.03 BASE COURSE

- A. Permeable Aggregate Base Course: Section 312300
- B. Geotextile Fabric: Section 312300
- C. Choker Course: Section 312300
- D. Storage Gravel: Section 312300

PART 3 - EXECUTION

3.01 EXAMINATION

- A. The integrity of the system is based on the accuracy of mix formulations and experienced workmen. Mixing is the on-site preparation of materials and the installation is the transport and handwork required to achieve a uniform surface. Before the installation of the protective surfacing system, the substrate of gravel base course shall be confirmed to be properly prepared for installation of playground surfacing. (NOTE: the protective surfacing installer is not responsible for settling of the surfaces if the stone base was not installed by the unitary surfacing installer).
- B. Proper drainage is critical to the longevity of the protective surfacing system. Inadequate drainage will cause premature breakdown of the poured system in affected areas; and void the warranty.

3.02 BASE COURSE PREPARATION

- A. Install Storage Gravel in accordance with Section 312300
- B. Install Choker Course in accordance with Section 312300
- C. Install Geotextile Fabric in accordance with Section 312300
- D. Install Permeable Aggregate Base Course in accordance with Section 312300,

3.03 INSTALLATION

- A. Do not proceed with playground surfacing installation until all applicable site work, including substrate preparation, fencing, playground equipment installation and other relevant work, has been completed.
- B. The required mix proportions for the cushion basemat and wearing course are established by the manufacturer by weight and are not to be altered by the installer without approval in writing from both the manufacturer and the Architect/Engineer.
 - 1. Basemat: 13-16 percent polyurethane binder to the weight of the SBR recycled materials (13-16 pounds per 100 pounds). Thoroughly mix the shred and granules to a uniform consistency with no globs or dry material noticeable. Do not mix longer than necessary for uniformity. After priming of all surrounding edges, place SBR cushion course and trowel the material to a uniform, smooth, surface to the required thickness and consistent density. If installing to meet an adjacent curb or similar vertical surface, compact a rolled 1/2 inch edge abutting the curb to allow for a full 1 inch EPDM wearing surface to enhance bonding. The cure rate may be accelerated with water spray after troweling.
 - 2. Wearing Course: minimum 20-22 percent polyurethane binder to the weight of the EPDM (20-22 pounds per 100 pounds). Mix thoroughly to a uniform consistency with no globs or dry material noticeable. Do not mix longer than necessary. Prime all edges of concrete curbs or walkways to the full depth of the surface, the perimeter of the base mat a minimum of 8 inches width and at high wear areas of the equipment- e.g., base of slide exits, steps etc. Screenshot the EPDM material to a uniform density to result in 2.2# per square foot when troweling a finished thickness of 1/2 inch. The finish troweling shall result in a uniform density, texture, and with smooth surface. Seams should be avoided, but if necessary due to weather, inlaid graphics or size of the pad, the previous laid surface shall be undercut at approximately 30 to 45 degrees, uniformly primed to accept the fresh compacted material which shall be placed to create a flush seam with uniform finish. Do not “step” a seam.

- C. After troweling the top EPDM layer mixed with standard aromatic binder, the cure rate of the surface may be accelerated with water spray. If Aliphatic binder is used NEVER spray the surface with water for any reason. At temperatures of greater than 70 degrees, allow a minimum cure time of 36-48 hours and do not allow foot traffic or use of the surface. The cure time is dependent upon the prevailing weather and the installer will advise of any additional precautions or time frame recommended prior to foot traffic or use. Coordinate the precautions and responsibility for security and protection of the work with the Construction Manager.

3.04 TESTING

- A. A Certified Playground Safety Inspector (CPSI) to confirm that all aspects of installed playground protective surfacing and play equipment are in compliance with the requirements identified in this Section. Contractor to submit documentation of CPSI approval to DEP.

3.05 CLEAN UP

- A. Comply with Section 017423.

3.06 CONTRACT CLOSEOUT

- A. Comply with Section 017700.

END OF SECTION 321816

NO TEXT ON THIS PAGE

SECTION 323111 – GATE OPERATORS

PART 1 - GENERAL

1.01 SUMMARY

A. Section Includes:

1. Electric Gate Operator System:

- a. Heavy-duty, industrial, rack-and-pinion-drive slide gate operators.
- b. Or Heavy-duty, industrial, chain driven, drive slide gate operators.
- c. Slide gate operator accessories.

B. The Contractor is to coordinate work with NJ Transit – access to NJ Transit train yard and Maintenance of Way (MOW) building parking lot is to be maintained at all times.

1.02 PAYMENT

A. No separate payment shall be made for performing any Work required under this Section. All costs for Work required by this Section shall be included in the applicable lump sum, unit price(s), or allowance(s) as set forth in Section 012901.

1.03 RELATED SECTIONS

- A. General Conditions Article 4.7 – Shop Drawings and Other Submittals
- B. General Conditions Article 4.10 - Testing
- C. Section 012901 – Measurement and Payment
- D. Section 014300 – Quality Requirements
- E. Section 016100 - Control of Materials

1.04 SUBMITTALS

A. Submit the following items in accordance with General Conditions Article 4.7.

- B. Product Data: Equipment list, system description, electrical wiring diagrams for installation, and manufacturer’s data sheets on each product to be used, including:
 - 1. Preparation instructions and recommendations.
 - 2. Storage and handling requirements and recommendations.
 - 3. Installation methods.
 - C. Shop Drawings: Submit shop drawings showing layout, profiles, and product components, including anchorage, edge conditions, and accessories.
 - 1. Operation, installation, and maintenance manuals including wiring diagrams.
 - 2. Risers, layouts, and special wiring diagrams showing any changes to standard drawings.
 - D. Qualification Data: For Installer.
 - E. Sample Warranty: For special warranty.
 - F. Maintenance Data: For electric gate operators to include in maintenance manuals.
- 1.05 DELIVERY, STORAGE, AND HANDLING
- A. Comply with the requirements specified in Section 016100.
 - B. Deliver, store, and handle materials and products in strict compliance with manufacturer’s instructions and industry standards.
 - C. Store products indoors in manufacturer’s original containers and packaging, with labels clearly identifying product name and manufacturer. Protect from damage.
- 1.06 QUALITY ASSURANCE
- A. Comply with the requirements specified in Section 014300
 - B. Manufacturer Qualifications: ISO 9001 Certified Manufacturer.
 - C. Installer Qualifications: Installation performed by factory authorized contractor specifically trained in gate operation systems of the type found within this section.
 - 1. Provide documentation of maintenance and repair service availability for emergency conditions.

2. Provide quarterly maintenance for one year following Substantial Completion of the Project.

1.07 WARRANTY

A. Manufacturer's Standard Limited Warranty:

1. Warranty Period: 2 years from date of Substantial Completion.

PART 2 - PRODUCTS

2.01 MANUFACTURERS

A. Subject to compliance with requirements, provide product by the following:

1. FAAC International Inc.
2. Door King
3. Gate Crafters
4. Lift Master
5. Aleko
6. Or approved equal

2.02 GATE OPERATORS

A. Gate Operators: The following manufactures and product systems shall be construed to mean the establishing of a minimum quality and performance standards for the specified item. All other products must be submitted to the authority for approval before they are deemed equal:

1. Basis-of-Design Product:
 - a. Gear Driven - FAAC, Model 844ER Z16 pinion slide gate operator.
 - b. Chain Driven – Door King, Model 9210-380 Operator
 - c. Chamberlain Group LiftMaster

- d. Or approved equal
2. Compliance: UL and ASTM Listed.
 - a. Compliant with UL 325, UL 991 and ASTM F2200.
 - b. Intended for use in Class III and IV vehicular slide gate applications.
3. Monitored Safety Inputs: For photo eyes and safety edges.
4. Operator Speed: 38 feet per minute (11.6 m per minute).
5. Electrical Power Requirements:
 - a. 115/208/230V AC, single phase, 60 Hz.
6. Accessory Electrical Power Requirements: 24V AC.
 - a. Main Board: 12V AC, maximum 500mA.
 - b. Terminal Strip:
 - 1) 2.2A maximum for 115/208-230V AC, single phase.
7. Gear Reduction: 20:1 wormgear reducer in synthetic oil bath.
8. Motor: 0.87 HP, 115 VAC 60Hz power supply.
 - a. Capacity: Supports gate weights up to 4,000 pounds (1814 kg).
 - b. Use Frequency: 70 percent.
9. Enclosure: NEMA 3R enclosure; oil tight, weatherproof NEMA 3R cabinet, lockable.
10. Gearbox: All-weather with Heating Kit.
11. Protective Treatment: Cathaphoresis
12. Lockout/Tagout: Prevents power from being switched on when servicing operator. Safeguards workers from high voltage power.
13. LED Diagnostic Display: For installation and troubleshooting sue.

14. Programmable Auxiliary Relays:
 - a. Pre-warning or gate-in motion sounder
 - b. Switch on/off devices at open or Close Limits or while gate is in motion.
 - c. Tamper detection if gate is pushed off Close Limit
 - d. Cycle quantity feedback.
 15. Quick Close, Anti-Tailgate: Quickly secures property, preventing unauthorized access.
 16. Plug-in Loop Detector Inputs: Programmed inputs for shadow, interrupt and exit.
 17. Warning Devices: UL 325 compliant entrapment warning alarm with ability to be set for pre-operation warning; provide a 3-second warning prior to and during gate movement.
 18. Lockable External Manual Disconnect: Allows gate to be opened in the event of a power loss without removing the operator cover.
 19. Clutch: Twin-disk oil-bath clutch.
 20. Operating Temperature Range:
 - a. Without heater: -4 degrees F (-20 degrees C) to 131 degrees F (55 degrees C).
- B. Accessories: Provide all accessories necessary for a complete, functional, and safe gate operator system, compliant with all applicable codes and standards.
1. Gear Rack
 2. Mounting Pedestal (Heavy Duty) for chain driven operator
 3. Transmitter
 4. Receiver
 5. Battery Backup
 6. Retro-Reflective Photocells

7. Through Beam Photobeams
8. Monitored Wireless Transmitter/Receiver
9. Wireless Monitored Safety Edge
 - a. Sensing edge
 - b. Mounting channel
10. Loop Detector
 - a. Provide shadow, interrupt and exit loop detection.
 - b. Loop detector
 - c. Loop Detector Loops
 - d. Loop Detector Sealant
11. Wireless Numerical Keypad Access Control System
12. Goose-Neck Post for Keypad

PART 3 - EXECUTION

3.01 EXAMINATION AND PREPARATION

- A. Inspect and prepare substrates using the methods recommended by the manufacturer for achieving best result for the substrates under project conditions.
- B. Do not proceed with installation until substrates have been prepared using the methods recommended by the manufacturer and deviations from manufacturer's recommended tolerances are corrected. Commencement of installation constitutes acceptance of conditions.

3.02 INSTALLATION

- A. Install in accordance with ASTM F2200 and manufacturer's instructions.

3.03 TESTING

- A. Refer to General Conditions Article 4.10.
- B. Test for proper operation and adjust to the satisfaction of NJ Transit.

3.04 TRAINING

- A. Provide minimum 4 hours training on each gate installed to NJ Transit personnel. Training to include mechanical, electrical and instrumentation operation and maintenance.

3.05 CONTRACT CLOSEOUT

- A. Provide in accordance with Section 017700.

END OF SECTION 323111

NO TEXT ON THIS PAGE

SECTION 323113 - CHAIN LINK FENCES AND GATES

PART 1 - GENERAL

1.01 DESCRIPTION

A. Section includes:

1. Chain link fence framework, fabric, and accessories.
2. Excavation for post bases.
3. Manual gates and related hardware.

1.02 PAYMENT

- A. No separate payment shall be made for performing any Work required under this Section. All costs for Work required by this Section shall be included in the applicable lump sum, unit price(s), or allowance(s) as set forth in Section 012901.

1.03 REFERENCES

A. American Association of State Highway and Transportation Officials (AASHTO):

1. M181: Standard Specification for Chain-Link Fence.

B. ASTM International (ASTM):

1. A53/A53M: Standard Specification for Pipe, Steel, Black and Hot-Dipped, Zinc-Coated, Welded and Seamless.
2. A121: Standard Specification for Metallic-Coated Carbon Steel Barbed Wire.
3. F567: Standard Practice for Installation of Chain-Link Fence.
4. F654: Standard Specification for Residential Chain Link Fence Gates.
5. F900: Standard Specification for Industrial and Commercial Swing Gates.
6. F1043: Standard Specification for Strength and Protective Coatings on Steel Industrial Fence Framework.
7. F1183: Standard Specification for Aluminum Alloy Chain Link Fence Fabric.
8. F1184: Standard Specification for Industrial and Commercial Horizontal Slide Gates.

C. Chain Link Fence Manufacturers Institute (CLFMI):

1. PM 2445: Chain Link Fence Manufacturers Institute Product Manual.

1.04 RELATED SECTIONS

- A. General Condition Article 4.7 – Shop Drawings and Other Submittals.
- B. Section 012901 – Measurement and Payment
- C. Section 014300 - Quality Requirements.
- D. Section 016100 - Control of Materials.
- E. Section 017423 – Cleaning Up.
- F. Section 017700 – Contract Closeout
- G. Section 033000 - Cast-In-Place Concrete

1.05 SUBMITTALS

- A. Submit the following in accordance with General Condition Article 4.7
 1. Submit Manufacturer's specifications, drawings, details and fence layout with appurtenances.
 2. Submit two samples of fencing materials. Mark or tag each sample and submit 30 days prior to erection of fence.
 3. Submit certified test reports with results of tests for fence finish.
 4. Submit shop drawings, samples and certificates simultaneously as one complete package.

1.06 SPARE PARTS

- A. Comply with the requirements specified in Section 016100.

1.07 QUALITY ASSURANCE

- A. Comply with the requirements specified in Section 014300.

1.08 DELIVERY STORAGE AND HANDLING

- A. Comply with the requirements specified in Section 016100.

1.09 FIELD CONDITIONS

- A. Field Measurements: Verify layout information for chain-link fences and gates shown on Drawings in relation to property survey and existing structures. Verify dimensions by field measurements.
- B. Preinstallation Inspection: Conduct inspections along the length of the Project. Several existing gates will be impacted by the installation of the flood structure, including, but not limited to:
 - 1. Sheet C302: West side of Jersey Avenue.
 - 2. Sheet C307: Along Washington Street, which may only require removal.

PART 2 - PRODUCTS

2.01 SYSTEM DESCRIPTION

- A. Provide chain link fence in accordance with AASHTO M181.
- B. Provide framework, fabric, accessories and gates in accordance with ASTM F567.
- C. Fence heights as indicated with top rail and bottom tension wire.
- D. Gates:
 - 1. Residential: Provide gates in accordance with ASTM F654.
 - 2. Industrial and Commercial:
 - a. Provide swing gates in accordance with ASTM F900.
 - b. Provide horizontal slide gates in accordance with ASTM F1184.

2.02 FENCE FABRIC

- A. General: Provide fabric in one-piece heights measured between top and bottom of outer edge of selvage knuckle or twist according to "CLFMI Product Manual" and requirements indicated below:
 - 1. Fabric Height: As indicated on the Contract Drawings or as measured in the field to match the existing.
 - 2. Steel Wire for Fabric: Wire diameter of 0.120 inch, or to match the existing.
 - a. Mesh Size: 2 inches, or to match the existing.

- b. Coat selvage ends of metallic-coated fabric before the weaving process with manufacturer's standard clear protective coating.
 3. Aluminum Wire Fabric: ASTM F1183, with mill finish, and wire diameter of 0.148 inch, or to match the existing.
 - a. Mesh Size: 2 inches, or to match the existing.
 4. Selvage: Knuckled at both selvages or twisted top and knuckled bottom, as determined in the field.

2.03 FENCE FRAMEWORK

- A. Posts and Rails: As shown on the drawings or as measured in the field to match the existing:
 1. Fence Height: As indicated on Drawings or as measured in the field.
 2. Industrial-Strength Materials: To match existing.
 - a. Line Post: To match existing, as approved by the Construction Manager.
 - b. End, Corner, and Pull Posts: To match existing, as approved by the Construction Manager.
 3. Horizontal Framework Members: Intermediate, top, and bottom rails according to ASTM F1043.
 - a. Top Rail: 1.66 inches in diameter or as measured in the field to match the existing.
 4. Brace Rails: ASTM F1043.
 5. Metallic Coating for Steel Framework:
 - a. Coatings: Any coating shall be submitted and approved by the Architect/Engineer prior to installation.

2.04 TENSION WIRE

- A. Provide Tension Wire for replacement fence to match the existing for material, diameter, coating, and finish.

2.05 TIE WIRES

- A. Tie wires, for fastening fence fabric to line posts and rails, not less than No. 6 gage aluminum wire.

- B. Tie wires, for fastening fence fabric to line posts and rails, not less than 9 gage (outside diameter) color matched PVC coated galvanized steel wire.

2.06 LINE POSTS

- A. 2-1/2 inches outside diameter steel pipe, conforming to AASHTO M181, or as approved by the Construction Manager to match the existing condition.

2.07 END, CORNER, AND PULL POSTS

- A. 3-inch outside diameter steel pipe conforming to AASHTO M181, or as approved by the Construction Manager to match the existing condition.

2.08 GATE POSTS

- A. 3-inch outside diameter steel pipe conforming to AASHTO M181, or as approved by the Construction Manager to match the existing condition.

2.09 RAILINGS

- A. 1-5/8 inch outside diameter steel pipe conforming to AASHTO M181, or as approved by the Construction Manager to match the existing condition.

2.10 TRUSS

- A. 3/8-inch diameter steel rod diagonal truss braces between terminal and adjacent line posts and for gate framework.

2.11 FITTINGS

- A. Heavy-duty malleable iron or pressed steel fittings of suitable size to produce strong construction.

2.12 STRETCHER BARS

- A. Flat bars with minimum cross section dimensions of 1/4-inch by 3/4-inch, full height of fabric, secured with bar bands of minimum 11-gage sheet steel, spaced approximately 15 inches on centers and bolted with 3/8-inch diameter bolts, for attaching fabric to terminal posts.

2.13 GATE LEAF FRAMEWORK

- A. 2-inch outside diameter steel pipe, conforming to ASTM F654 or F900, and as approved by the Construction Manager to match the existing condition.

2.14 GATE HINGES

- A. Heavy pattern of adequate strength for gate size, with large bearing surfaces for clamping or bolting in position.

2.15 LATCH

- A. Gates with suitable latch, accessible from both sides and with provision for padlocking.

2.16 GATE PADLOCKS

- A. Gate padlocks to be provided by the property owner.

2.17 CONCRETE FOOTINGS

- A. Section 033000 - Cast-In-Place Concrete, Class A concrete.

2.18 GROUT

- A. One-part Portland cement and three parts of clean, sharp, well-graded sand with minimum water for proper workability for posts set in solid rock.

2.19 ACCESSORIES

- A. Steel pipe dimensions and weights: ASTM A53/A53M, Schedule 40. Dimensions specified are nominal pipe sizes.
- B. Dimensions and weight tolerances: Plus or minus 5 percent.
- C. Zinc Coating: Minimum 2.0 ounces per square foot.
- D. Provide posts with tops of same material and designed to fit securely over post and carry top rail. Carry apron around outside of post at base of top fitting.
- E. Ferrous metal fittings, posts, fence, gate framework, and accessories galvanized with heavy coating of 2.0 oz/ft² pure zinc spelter per square foot or surface area to be coated. Use hot-dip process. Thinner zinc coatings, electro-galvanizing, zinc paint or cold galvanizing compounds not used as substitute for hot-dipped galvanized finish not acceptable.
- F. Fabricate and weld before hot-dip galvanizing. Weld conforming to American Welding Society standards.
- G. Hot-dip galvanized gate frame, after welding, if bolted or riveted corner fittings not used.

- H. If needed to match existing fence, galvanize fittings, posts, fence and gate framework, and accessories, then epoxy phenolic primed and top coated with matching PVC, using thermal bond process.
- I. Single and double leaf swing gates with center bolt, center stop, and automatic backstops.

2.20 BARBED WIRE

- A. Steel Barbed Wire: ASTM A121, two-strand barbed wire, diameter, line wire- diameter, and barbs spaced to match existing.
 - 1. Aluminum Coating: Type A.
 - 2. Zinc Coating: Type Z, Class 3.

PART 3 - EXECUTION

3.01 EXAMINATION

- A. Examine conditions under which fence and gates are to be installed. Notify Construction Manager in writing, of improper conditions of work.
- B. Do not proceed with work until unsatisfactory conditions have been corrected.
- C. Verify measurements at site.
- D. Check location of underground work to make sure fence footings clear utilities and drainage work.
- E. Do not install fence until final grading is complete and finish elevations are established.
- F. Do not drive equipment on areas to be landscaped, except as accepted by Construction Manager. Areas not accessible from roads shall be protected with heavy wood planking. Remove barricades and protection at completion of project. Repair damaged landscape surfaces.

3.02 INSTALLATION

- A. Install chain-link fencing according to ASTM F567 and more stringent requirements specified.
 - 1. Install fencing on established boundary lines inside property line.
- B. Footings:

1. Vertical sides to minimize up-lift. Dispose of excavated material in accordance with Section 017423.
2. Rod and compact concrete around posts. Slope top of footings above level of adjacent grade, and trowel finish.
3. Size:
 - a. Post Excavation: Drill or hand-excavate holes for posts to diameters and spacings indicated, in firm, undisturbed soil.
4. Time of Set: 48 hours before rails are erected or before fabric is applied or stretched.

C. Framing:

1. Install line posts not more than 10 feet apart.
2. Install pull posts not more than 600 feet apart where a straight run of fence exceeds 600 feet and where fence line changes direction by more than 15 degrees but less than 30 degrees.
3. Install corner posts where the fence line changes direction by more than 30 degrees.
4. Set posts in concrete footings, plumb and true to line.
5. Brace and truss end, pull, corner, and gate posts to adjacent line posts. Provide brace to match top rail spaced midway between top rail and tension wire and extending to adjacent line posts. Provide brace to match top rail spaced midway between top rail and tension wire and extending to adjacent line post. Truss diagonally with 3/8-inch diameter tension rod with turnbuckle.
6. Fasten top rail to end, pull, gate and corner posts. Pass top rail through fittings of line posts.
7. Provide expansion and contraction joints in top rail for each 100 linear feet of fence.
8. Fasten bottom tension wire to end, pull, gate, corner, and line posts.
9. Maximum area of unbraced fence shall not exceed 1,500 square feet.
10. Use galvanized sleeve and grout posts or install with suitable galvanized flange casings and galvanized anchor bolts as accepted by Construction Manager.
11. When rock is encountered, set posts into rock a minimum depth of 12 inches for line posts and 18 inches for terminal posts. If solid ledge is encountered without

overburden of soil. Provide post holes at least 1 inch greater in diameter than post, fill post holes with concrete work post into hole taking care not to cause voids, remove excess concrete and crown remainder at top to shed water. Where solid rock is covered by overburden, do not exceed total setting depth required for setting in earth, grout posts into rock as described.

12. Where fence terminates adjacent to the Resist Structure, secure a 6-inch x 6-inch x ¼-inch galvanized steel base plate with a galvanized chain link surface mount floor flange to the structure slab using 4 wedge anchors (½ inch x 4 ¼ inch). Grout and secure posts as accepted by Construction Manager.

D. Fabric:

1. Place fabric on outside of posts and stretch to avoid bulging or buckling.
2. Fasten at line posts, top rail, and bottom tension wire with aluminum or zinc PVC coated ties. Space ties not more than 10 inches apart on line posts and not more than 12 inches apart on rail and tension wire.
3. Fasten at terminal posts at intervals not exceeding 10 inches using flat or beveled galvanized steel bands with 5/16-inch galvanized carriage bolts and nuts.
4. Make tie connections on interior side of fence.
5. Install barbed wire to match adjoining existing fence.
 - a. Install three strands of barbed wire on each extension arm of line fence and at top of each gate. Pull wires taut and fasten at each support.
 - b. Install barbed wire on extension arms as indicated. Pull each wire taut, and make entire assembly secure Attach wire to end, corner, pull, and gate posts with wire stretching bands.
6. Install gates plumb, level, and secure for full width of opening and hardware adjusted for smooth operation.
7. Electrical Ground where a power line carrying more than 600 volts passes over fence, install ground rod at nearest point directly below each point of crossing.

3.03 REPAIR

- A. Remove and replace fencing which is improperly located or is not true to line, grade and plumb within tolerances as indicated.
- B. Repair damaged vinyl-coated components as recommended by manufacturer.

3.04 CONTRACT CLOSEOUT

- A. Provide in accordance with Section 017700.

END OF SECTION 323113

SECTION 323119 - DECORATIVE METAL (PICKET) FENCES AND GATES

PART 1 - GENERAL

1.01 DESCRIPTION

- A. Provide decorative metal fences and gates as indicated and in compliance with Contract Documents.

1. Section Includes:

- a. Decorative metallic-coated steel tubular picket fences.
- b. Decorative metallic-coated steel security fences.
- c. Decorative steel fences.
- d. Decorative aluminum fences.
- e. Swing gates.

1.02 PAYMENT

- A. No separate payment shall be made for performing any Work required under this Section. All costs for Work required by this Section shall be included in the applicable lump sum(s), as set forth in Section 012901.

1.03 REFERENCES

- A. ASTM International (ASTM):

1. C387: Standard Specification for Packaged, Dry, Combined Materials for Mortar and Concrete
2. C1107: Standard Specification for Packaged Dry, Hydraulic-Cement Grout (Non-shrink)
3. F1184: Standard Specification for Industrial and Commercial Horizontal Slide Gates
4. F2408: Standard Specification for Ornamental Fences Employing Galvanized Steel Tubular Pickets
5. F2589: Standard Specification for Ornamental Fences Employing Steel Tubular Pickets

6. F2814: Standard Guide for Design and Construction of Ornamental Steel Picket Fence Systems for Security Purposes
- B. American Welding Society (AWS):
1. D1.1/D1.1M: Structural Welding Code.
 2. D1.2/D1.2M: Structural Welding Code – Aluminum
- C. Federal Regulations:
1. 40 CFR 59, Subpart D: National Volatile Organic Compound Emission Standards for Consumer and Commercial Products
- D. Institute of Electrical and Electronics Engineers (IEEE):
1. C2: National Electrical Safety Code
 2. 81: Guide for Measuring Earth Resistivity, Ground Impedance, and Earth Surface Potentials of a Ground System
- E. National Fire Protection Association (NFPA):
1. 70: National Electrical Code
 2. 780: Standard for the Installation of Lightning Protection Systems
- F. Underwriters' Laboratories, Inc. (UL):
1. 467: Standard for Safety Grounding and Bonding Equipment

1.04 RELATED SECTIONS

- A. General Condition Article 4.7 – Shop Drawings and Other Submittals.
- B. Section 011100 – Summary of Work.
- C. Section 012901 – Measurement and Payment.
- D. Section 014300 - Quality Requirements.
- E. Section 016100 - Control of Materials.
- F. Section 017423 – Cleaning Up.
- G. Section 017700 – Contract Closeout.
- H. Section 033000 – Cast-In-Place Concrete.

1.05 SUBMITTALS

- A. Submit the following shop drawings in accordance with General Conditions 4.7
- B. Product Data: For each type of product indicated.
- C. Shop Drawings: For gates. Include plans, elevations, sections, details, and attachments to other work.
- D. Samples: For each fence material and for each color specified.
 - 1. Provide Samples 12 inches in length for linear materials.
 - 2. Provide Samples 12 inches square for bar grating.
 - 3. Provided Samples for surface mount floor flanges.
- E. Welding certificates.
- F. Product Test Reports: Based on evaluation of comprehensive tests performed by a qualified testing agency, for metal picket fences, including finish, indicating compliance with referenced standard and other specified requirements.
- G. Maintenance Data: For gate operators to include in maintenance manuals.

1.06 QUALITY ASSURANCE

- A. Comply with the requirements specified in Section 014300.
- B. Installer Qualifications: Installer to have a minimum of three (3) years installing fencing and gates similar to those described in the Contract Documents.
- C. Welding Qualifications: Qualify procedures and personnel according to AWS D1.1/D1.1M, "Structural Welding Code - Steel or AWS D1.2/D1.2M, "Structural Welding Code – Aluminum".
 - 1. Include 10-footlength of fence complying with requirements.
 - 2. Approved mockups may become part of the completed Work if undisturbed at time of Substantial .

1.07 DELIVERY STORAGE AND HANDLING

- A. Comply with the requirements specified in Section 016100.

1.08 PROJECT/SITE CONDITIONS

- A. Field Measurements: Verify layout information for chain-link fences and gates shown on Drawings in relation to property survey and existing structures. Verify dimensions by field measurements. Verify location of gates and size of openings.
- B. Preinstallation Inspection: Conduct inspections along the length of the Project. Several existing gates may be impacted by the installation of the flood structure.

1.09 COORDINATION

- A. Coordinate work for metal picket fence systems with work of other trades as required to provide a complete system.
- B. Existing Metal Picket Fence removed for the construction of the Resist Structure shall be stockpiled and preserved for reuse on the Project or return to the property owner, as directed by the Construction Manager.

PART 2 - PRODUCTS

2.01 DECORATIVE METAL PICKET FENCE SYSTEMS

- A. Submit manufacturer's catalog data that matches the existing gate system in size and design for approval of the Architect/Engineer. Where a new system is required, provide ASTM F2814 structural components consisting of tubular steel ornamental pickets and rails.
- B. Provide ASTM F2408 or ASTM F2589 industrial class pickets with a cross-sectional area and minimum wall thickness to match the adjacent existing fence system. For replacement fencing on Marin Boulevard and Observer Highway, provide pickets with bent, spear-pointed tips extending above the top rail of the fence. Mount pickets to a top and bottom rail spaced to match the existing. Space pickets along rails with a maximum gap not to exceed 5.5 cm 2.25 in. Secure pickets to rails by welding. Provide all items and accessories finished painting in black, or to match the existing.
- C. Accessories are specified separately in this section.
- D. Ornamental Fence Gates
 - 1. Swing Gates: Submit manufacturer's catalog data that matches the existing gate system in size and design for approval of the Architect/Engineer. Fabricate swing gates by welding tubular steel ends and rails. Use pickets that match the adjacent fence construction. Reinforce gates to ensure assembly sags no more than 1% of the gate leaf width or 2 in, whichever is less. Size gate posts to accommodate the weight and width of each gate leaf. Mount gates to posts with weldable steel plates or blocks, pressed steel, or malleable iron hinges. Hot-dip galvanize all hinges with

a minimum zinc weight of 1.20 oz/sq ft. Secure all tamper points by welding or peening the threads. Use swing gate latches and drop bar guides manufactured of pressed steel, hot-dipped galvanized with a minimum zinc weight of 1.20 oz/sq ft. Finish all gate hardware in the same color/coating as the fence system.

2. Slide Gates: Submit manufacturer's catalog data that matches the existing gate system in size and design for approval of the Architect/Engineer. Fabricate slide gates by welding tubular steel ends and rails. Use pickets that match the adjacent fence construction. Select the type and class of slide gate to comply with ASTM F1184. Size gate posts to accommodate the weight and width of each gate leaf in accordance with ASTM F1184, or per manufacturer's recommendations.

2.02 MISCELLANEOUS MATERIALS

- A. Concrete: Normal-weight, air-entrained, ready-mix concrete complying with requirements in Section 033000 with a minimum 28-day compressive strength of 3000 psi, 3-inch slump, and 3/4-inch maximum aggregate size or dry, packaged, normal-weight concrete mix complying with ASTM C387 mixed with potable water according to manufacturer's written instructions.
- B. Nonshrink Grout: Factory-packaged, nonstaining, noncorrosive, nongaseous grout complying with ASTM C1107 and specifically recommended by manufacturer for exterior applications.

2.03 GROUNDING MATERIALS

- A. Lightning-Protection System: Maximum grounding-resistance value of 25 ohms under normal dry conditions.
- B. Grounding Conductors: Bare, solid wire for No. 6 AWG and smaller; stranded wire for No. 4 AWG and larger.
 1. Material above Finished Grade: Copper.
 2. Material on or below Finished Grade: Copper.
 3. Bonding Jumpers: Braided copper tape, 1 inch wide, woven of No. 30 AWG bare copper wire, terminated with copper ferrules.
- C. Grounding Connectors and Grounding Rods: Comply with UL 467.
 1. Grounding Rods: Copper-clad steel.
 - a. Size: 5/8 by 96 inches.

PART 3 EXECUTION

3.01 EXAMINATION

- A. Examine areas and conditions, with Installer present, for compliance with requirements for site clearing, earthwork, pavement work, construction layout, and other conditions affecting performance of the Work.
- B. Do not begin installation before final grading is completed unless otherwise permitted by Construction Manager.
- C. Proceed with installation only after unsatisfactory conditions have been corrected.
- D. Examine condition of stockpiled fence materials removed to facilitate construction of the Resist Structure for reuse.

3.02 PREPARATION

- A. Stake locations of fence lines, gates, and terminal posts. Do not exceed intervals of 500 feet or line of sight between stakes. Indicate locations of utilities, lawn sprinkler system, underground structures, benchmarks, and property monuments.
 - 1. Construction layout and field engineering to be performed within the guidelines in Section 011100.

3.03 DECORATIVE FENCE INSTALLATION

- A. Install fences according to manufacturer's written instructions and to the lines and grades indicated.
- B. Clear the area on either side of the fence line to the extent indicated. Space line posts equidistant at intervals not exceeding 10 feet. Set terminal (corner and gate) posts whenever abrupt changes in vertical and horizontal alignment are encountered. Install fences by setting posts as indicated and fastening rails and infill panels to posts.
- C. Post Excavation: Drill or hand-excavate holes for posts in firm, undisturbed soil. Excavate holes to the diameter and the depth indicated on the Plans.
- D. Post Setting: Set posts in concrete at indicated spacing into firm, undisturbed soil.
 - 1. Verify that posts are set plumb, aligned, and at correct height and spacing, and hold in position during setting with concrete or mechanical devices.
 - 2. Concrete Fill: Place concrete around posts and vibrate or tamp for consolidation. Protect aboveground portion of posts from concrete splatter.

- a. Exposed Concrete: Extend 2 inches above grade. Finish and slope top surface to drain water away from post.
 - b. Concealed Concrete: Top below grade as indicated on Drawings to allow covering with surface material. Slope top surface of concrete to drain water away from post.
3. Posts Set in Concrete: Extend post to the depth indicated on the Plans.
 4. Space posts uniformly at 10 feet o.c.
 5. Posts Set on Concrete Slabs: Where fence terminates adjacent to the Resist Structure, secure a 6-inch x 6-inch x ¼-inch galvanized steel base plate with a galvanized surface mount floor flange to the structure slab using 4 – ½ inch x 4 ¼ inch wedge anchors. Grout and secure posts as accepted by Construction Manager.

3.04 GATE INSTALLATION

- A. Reinstall existing gates, or install new gates according to manufacturer's written instructions, level, plumb, and secure for full opening without interference. Mount gates to swing as indicated. Attach hardware using tamper-resistant or concealed means. Install ground-set items in concrete for anchorage. Adjust hardware for smooth operation and lubricate where necessary.

3.05 GROUNDING AND BONDING

- A. Fence Grounding: Install at maximum intervals of 1500 feet (450 m) except as follows:
 1. Fences within 100 Feet of Buildings, Structures, Walkways, and Roadways: Ground at maximum intervals of 750 feet (225 m).
 - a. Gates and Other Fence Openings: Ground fence on each side of opening.
 - (1) Bond metal gates to gate posts.
 - (2) Bond across openings, with and without gates, except openings indicated as intentional fence discontinuities. Use No. 2 AWG wire and bury it at least 18 inches below finished grade.
- B. Protection at Crossings of Overhead Electrical Power Lines: Ground fence at location of crossing and at a maximum distance of 150 feet on each side of crossing.
- C. Grounding Method: At each grounding location, drive a grounding rod vertically until the top is 6 inches below finished grade. Connect rod to fence with No. 6 AWG conductor. Connect conductor to each fence component at the grounding location.
- D. Bonding Method for Gates: Connect bonding jumper between gate post and gate frame.

- E. Connections: Make connections so possibility of galvanic action or electrolysis is minimized. Select connectors, connection hardware, conductors, and connection methods so metals in direct contact will be galvanically compatible.
 - 1. Use electroplated or hot-tin-coated materials to ensure high conductivity and to make contact points closer in order of galvanic series.
 - 2. Make connections with clean, bare metal at points of contact.
 - 3. Make aluminum-to-steel connections with stainless-steel separators and mechanical clamps.
 - 4. Make aluminum-to-galvanized-steel connections with tin-plated copper jumpers and mechanical clamps.
 - 5. Coat and seal connections having dissimilar metals with inert material to prevent future penetration of moisture to contact surfaces.
- F. Bonding to Lightning-Protection System: If fence terminates at lightning-protected building or structure, ground the fence and bond the fence grounding conductor to lightning-protection down conductor or lightning-protection grounding conductor, complying with NFPA 780.

3.06 FIELD QUALITY CONTROL

- A. Grounding-Resistance Testing: Contractor shall engage a certified qualified testing agency to perform tests and inspections. Test reports shall be submitted to Construction Manager daily.
 - 1. Grounding-Resistance Tests: Subject completed grounding system to a megger test at each grounding location. Measure grounding resistance not less than two full days after last trace of precipitation, without soil having been moistened by any means other than natural drainage or seepage and without chemical treatment or other artificial means of reducing natural grounding resistance. Perform tests by two-point method according to IEEE 81.
 - 2. Excessive Grounding Resistance: If resistance to grounding exceeds specified value, notify Construction Manager promptly. Include recommendations for reducing grounding resistance and a proposal to accomplish recommended work.
 - 3. Report: Prepare test reports certified by a testing agency of grounding resistance at each test location. Include observations of weather and other phenomena that may affect test results.

3.07 ADJUSTING

- A. Gates: Adjust gates to operate smoothly, easily, and quietly, free of binding, warp, excessive deflection, distortion, nonalignment, misplacement, disruption, or malfunction, throughout entire operational range. Confirm that latches and locks engage accurately and securely without forcing or binding.
- B. Lubricate hardware and other moving parts.

3.08 REPAIR OF DEFECTIVE WORK

- A. Remove stained or otherwise defective work and replace with material that meets specification requirements.
- B. Repair damaged finish as directed by the Construction Manager.
- C. Replace defective or damaged components as directed by the Construction Manager.

3.09 FINAL CLEANING

- A. Comply with the requirements of Section 017423
- B. As installation is completed, wash thoroughly using clean water and soap; rinse with clean water.
- C. Do not use acid solution, steel wool or other harsh abrasives.
- D. If stain remains after washing, remove finish and restore in accordance with NAAMM/NOMMA Metal Finishes Manual.
- E. For stainless steel, clean all metal work with Q-Rail "Q-Ultra-Clean" or similar product to prevent "tea staining" of stainless steel.
- F. Clean up debris and unused material, and remove from site.

3.10 CONTRACT CLOSEOUT

- A. Provide in accordance with Section 017700.

END OF SECTION 323119

NO TEXT ON THIS PAGE

SECTION 323300 - BOLLARDS

PART 1 - GENERAL

1.01 DESCRIPTION

- A. Provide site furnishings as indicated and in compliance with Contract Documents.
 - 1. Scope includes:
 - a. Bollards.

1.02 PAYMENT

- A. No separate payment shall be made for performing any Work required under this Section. All costs for Work required by this Section shall be included in the applicable lump sum, unit price(s), or allowance(s) as set forth in Section 012901.

1.03 REFERENCES

- A. ASTM International (ASTM)
 - 1. A36/A36M: Standard Specification for Carbon Structural Steel.
 - 2. A53/A53M: Standard Specification for Pipe, Steel, Black and Hot-Dipped, Zinc-Coated, Welded and Seamless.
 - 3. A135/A135M: Standard Specification for Electric-Resistance-Welded Steel Pipe.
 - 4. A500/A500M: Standard Specification for Cold-Formed Welded and Seamless Carbon Steel Structural Tubing in Rounds and Shapes.
 - 5. A513/A513M: Standard Specification for Electric-Resistance-Welded Carbon and Alloy Steel Mechanical Tubing.
 - 6. A1011/A1011M: Standard Specification for Steel, Sheet and Strip, Hot-Rolled, Carbon, Structural, High-Strength Low-Alloy, High-Strength Low-Alloy with Improved Formability, and Ultra-High Strength.
 - 7. C1107/C1107M: Standard Specification for Packaged Dry, Hydraulic-Cement Grout (Nonshrink).
 - 8. D4956. Standard Specification for Retroreflective Sheeting for Traffic Control.
- B. American Welding Society
 - 1. D1.1/D1.1M: Structural Welding Code-Steel.

1.04 RELATED SECTIONS

- A. General Conditions Article 4.7 – Shop Drawings and Other Submittals.
- B. Section 012901 – Measurement and Payment.

1.05 SUBMITTALS

- A. Submit the following items in accordance with General Conditions Article 4.7
- B. Product Data: For each type of product.
- C. Samples: For each exposed product and for each color and texture specified.
- D. Samples for Initial Selection: For units with factory-applied finishes.

PART 2 - PRODUCTS

2.01 BOLLARDS

- A. Bollard Construction:
 - 1. Pipe OD: Not less than 6 inches>.
 - a. Steel: Schedule 40 pipe.
 - 2. Style: As indicated in the details.
 - 3. Overall Height: As indicated.
 - 4. Overall Width: As indicated.
 - 5. Overall Depth: As indicated.
 - 6. Accessories: As indicated in the details.
 - 7. Installation Method: Cast in concrete, bolted to cast-in anchor bolts or as indicated in the details.
- B. Steel Finish: Color coated.
 - 1. Color: As selected by Architect/Engineer from manufacturer's full range for Safety Yellow.
- C. Reflective Collar Strip:
 - 1. A 2-inch-wide yellow reflective collar strip, Class 1 and conforming to ASTM D4956, shall be adhered to the unpainted full circumference of each bollard.

2.02 MATERIALS

- A. Steel and Iron: Free of surface blemishes and complying with the following:
 - 1. Plates, Shapes, and Bars: ASTM A36/A36M.
 - 2. Steel Pipe: Standard-weight steel pipe complying with ASTM A53/A53M, or electric-resistance-welded pipe complying with ASTM A135/A135M.
 - 3. Tubing: Cold-formed steel tubing complying with ASTM A500/A500M.
 - 4. Mechanical Tubing: Cold-rolled, electric-resistance-welded carbon or alloy steel tubing complying with ASTM A513/A513M, or steel tubing fabricated from steel complying with ASTM A1011/A1011M and complying with dimensional tolerances in ASTM A500/A500M; zinc coated internally and externally.
 - 5. Sheet: Commercial steel sheet complying with ASTM A1011/A1011M.
- B. Anchors, Fasteners, Fittings, and Hardware: Stainless steel; commercial quality, tamperproof, vandal and theft resistant, concealed, recessed, and capped or plugged, as required.
- C. Nonshrink, Nonmetallic Grout: Premixed, factory-packaged, nonstaining, noncorrosive, nongaseous grout complying with ASTM C1107/C1107M; recommended in writing by manufacturer, for exterior applications.

2.03 FABRICATION

- A. Metal Components: Form to required shapes and sizes with true, consistent curves, lines, and angles. Separate metals from dissimilar materials to prevent electrolytic action.
- B. Welded Connections: Weld connections continuously. Weld solid members with full-length, full-penetration welds and hollow members with full-circumference welds. At exposed connections, finish surfaces smooth and blended, so no roughness or unevenness shows after finishing and welded surface matches contours of adjoining surfaces.
- C. Exposed Surfaces: Polished, sanded, or otherwise finished; all surfaces smooth, free of burrs, barbs, splinters, and sharpness; all edges and ends rolled, rounded, or capped.
- D. Factory Assembly: Factory assemble components to greatest extent possible to minimize field assembly. Clearly mark units for assembly in the field.

2.04 GENERAL FINISH REQUIREMENTS

- A. Appearance of Finished Work: Noticeable variations in same piece are unacceptable. Variations in appearance of adjoining components are acceptable if they are within the range of approved Samples and are assembled or installed to minimize contrast.

2.05 STEEL AND GALVANIZED-STEEL FINISHES

- A. Bollards shall be painted with a Prime Coat (Gray organic zinc-rich epoxy primer) and two (2) topcoats of Safety Yellow Latex.

PART 3 - EXECUTION

3.01 EXAMINATION

- A. Examine areas and conditions, with Installer present, for compliance with requirements for correct and level finished grade, mounting surfaces, installation tolerances, and other conditions affecting performance of the Work.
- B. Proceed with installation only after unsatisfactory conditions have been corrected.

3.02 INSTALLATION

- A. Unless otherwise indicated, install site furnishings after landscaping and paving have been completed.
- B. Install site furnishings level, plumb, true, and securely anchored or positioned at locations indicated on the Contract Drawings.
- C. Post Setting: Set cast-in support posts in concrete footing with smooth top, shaped to shed water. Protect portion of posts above footing from concrete splatter. Verify that posts are set plumb or at correct angle and are aligned and at correct height and spacing. Hold posts in position during placement and finishing operations until concrete is sufficiently cured.
- D. The Bollards shall be constructed using the steel tubing as previously specified and to the dimensions shown on the plans. The steel tubing shall be sawcut and welded, as required. Welds shall be made smooth and flush. All welds shall be of A36 steel and in accordance with the AWS Welding Code. Do not field cut or alter members unless approved by the Construction Manager.
- E. Surfaces to be painted shall be prepared and paint applied as follows:
 - 1. Exposed surfaces shall be clean of all grease, oil, mill scale, dirt, concrete, rust, old paint or any other contaminants.
 - 2. Prime coat shall be applied at 3.0 – 4.0 mils Dry Film Thickness.
 - 3. Two (2) topcoats shall be applied each at 1.5 mils Dry Film Thickness. A minimum of 24 hours shall be allowed between coats for the preceding coat to dry completely.

4. Application shall be by brush or spraying. Adjacent surfaces shall be protected. Contractor shall be responsible for damage by overspray and airborne paint particles.
5. Paint shall not be applied when the air temperature in the shade is below 40 degrees F or when the surface is wet. Paint shall not be applied when inclement weather conditions are pending. Contractor shall repaint if weather affects drying.

3.03 CONTRACT CLOSEOUT

- A. Refer to Section 017700.

END OF SECTION 323300

NO TEXT ON THIS PAGE

SECTION 323900 – MANUFACTURED SITE SPECIALTIES

PART 1 - GENERAL

1.01 SUMMARY

- A. Provide coordination of work and fabrication of steel and wood system for manufactured site specialty elements as indicated in this Section and in compliance with Contract Documents. Work includes the fabrication of units by qualified single source fabricator who will provide final design, engineering, fabrication, and delivery to site for installation.

1. Manufactured site specialty elements include:
 - a. Bench Type 1
 - b. Barstool Seating
 - c. Plaza Planters with Wood Seat Tops
 - d. Entry Signage
 - e. Amphitheater Wood Top Seating
2. Metal fabrications for the framing and support systems.
3. Woodwork to be installed on metal support systems.
4. Installation of the elements as identified in this Section is to be efficient and can be installed by the fabricator or Contractor.

1.02 PAYMENT

- A. No separate payment shall be made for performing any Work required under this Section. All costs for Work required by this Section shall be included in the applicable Cove Park lump sum(s) as set forth in Section 012901.

1.03 RELATED SECTIONS

- A. General Conditions Article 4.7 – Shop Drawings and Other Submittals
- B. Section 012901 - Measurement and Payment
- C. Section 014300 – Quality Requirements

- D. Section 016100 – Control of Materials
- E. Section 017423 – Cleaning Up
- F. Section 017700 - Contract Closeout
- G. Section 050513 – Shop Applied Coatings For Metal
- H. Section 055001 – Site Metal Fabrications
- I. Section 061533 - Decking
- J. Section 062013 – Exterior Finish Carpentry

1.04 REFERENCES

- A. ALSC – American Lumber Standard Committee
- B. AWWA – American Wood Preservers’ Association
- C. FSC – Forest Stewardship Council
- D. Wood items and requirements, refer to Section 062013
- E. Metal items and requirements, refer to Section 055001

1.05 DEFINITIONS

- A. Acceptance, Acceptable, or Accepted: Acceptance by the Architect/Engineer.

1.06 REQUIREMENTS

- A. Provide all fabrications (or listed elements) are under the requirements of a coordinated fabrication as outlined under Section 329200 – Manufactured Site Specialties. All design and fabrication to be fully coordinated during review, fabrication, assembly and installation.
- B. Contractor Design: All work associated with elements in this Section is to be performed as a delegated design and build. Contractor is to provide final design, engineering, fabrication.
 - 1. General: Design and engineering of custom bench type 1, custom barstool seating, plaza planters with wood seat tops, entry signage, amphitheater wood top seating, and metal retaining wall type 2 elements to be developed in accordance with building codes for structural loads and capacities.
 - 2. Contractor to provide all calculations and analysis necessary to complete the Work.

3. Contractor is to coordinate work of others associated with or attached to features in this Section including but not limited to:
 - a. Precast architectural concrete stairs.
 - b. Retaining walls.
 - c. Cast in place concrete pathways.
 - d. Resin bound aggregate paving.
 - e. Unit pavers.
 - f. Planting.
 - g. Artificial Turf.
 - h. Decking.
 - i. Resist Structure.
 - j. LED Lighting.
 - C. Furnish all transportation, labor, materials and equipment to perform the following:
Furnish and install features in this Section and accessories necessary to complete the Work.
 - D. The fabricator is to provide:
 1. Responsibility for the engineering of the seating module to comply with performance requirements to local jurisdiction and matching the design intent shown in drawings. This responsibility includes the preparation of Shop Drawings and comprehensive engineering analysis by a qualified professional engineer.
 2. Has sufficient production capacity to produce required units without delaying the Work.
 3. Will provide field staff to provide guidance to the Contractor.
- 1.07 SUBMITTALS
- A. Submit the following in accordance with General Conditions Article 4.7.
 - B. Product Data: Manufacturer’s descriptive literature and standard drawings for stock products and materials to be used including but not limited to:

1. Wood boards
2. Fasteners
3. Metals
4. Setting systems

C. Samples for Verification:

1. Graded wood samples for Construction Manager and Landscape Architect review and approval for wood slats in specified profiles, wood species, texture, and intended finish.
2. Submit for acceptance prior to wood purchase and millwork fabrication.
3. Provide specified or indicated finish applied in step fashion to samples showing unfinished wood and each applied coatings.
4. Metal finishes and coatings.

D. Shop Drawings: Prepare Project-specific information, drawn accurately to scale. Submit Large-scale dimensioned drawings, showing detail fabrication and installation of each element indicated in the drawings. Indicate locations, plans, elevations, dimensions, shapes, and cross sections. Do not base Shop Drawings on reproductions of the Contract Documents or standard printed data. Shop Drawings are to be coordinated with all relevant, related and adjacent components in accordance with Section 055001, Section 062013, and including but not limited to 1.07 D17 herein.

1. Preparation: Fully illustrate requirements in the Contract Documents. Include the following information, as applicable:
2. Identification of all products used in fabrication(s).
3. Indicate jointing, reveals, patterns, and extent and location of each surface finishes.
4. Schedules of parts, fabrication pieces, hardware, anchors, and finishes.
5. Indicate locations, tolerances, and details of anchorage devices to be embedded in or attached to the structure or other construction.
6. Compliance with specified standards and codes.
7. Notation of coordination requirements, sequencing of work.
8. Notation of dimensions established upon actual field conditions.

9. Field verification relating to conditions of the site and adjacent structures. Where items must fit and coordinate with finished surfaces and/or constructed spaces, take measurements at the site and not from drawings.
10. Relationship and attachment to adjoining construction clearly indicated.
11. Fully fabricated unit(s). Drawings to show work by multiple trades in a single drawing set to assure coordination of work.
12. Drawings to show relationships for both vertical and horizontal controls for use for in the placement of work.
13. Details are to show landscape metalwork and concrete with any penetrations through the veneer, foundations, including vents, posts, and lighting.
14. Provide templates for setting work for use by the Contractor for installation.
15. Seal and signature of a professional engineer if required by code Engineer to have registration in the state of location of the project.
16. Provide templates for other fabricator use and installation work.
17. Shop Drawings shall be coordinated with all conditions and provide:
 - a. 1/4" = 1'-0" for all elevation and plans views for items showing layout and conditions of the site.
 - b. 1" = 1'-0" larger elevation and/or section views of all work locations.
 - c. 1 1/2" = 1'-0" and 3" = 1'-0" for all details depicting fasteners, connections, and small fabrication elements.
 - d. Furnish 3-dimensional or isometric drawings for conditions too difficult to illustrate in 2-dimensional orthographic projections.
18. Shop Drawings are to be coordinated with all relevant, related and adjacent components including but not limited to the following:
 - a. Wood Components.
 - b. Light Poles, LED Strip Lighting, Junction Boxes and Other Electrical Components.
 - c. Concrete Footings.
 - d. Pile Supports.

- e. Retaining Walls.
 - f. Precast Architectural Concrete Steps.
 - g. Handrails.
 - h. Guardrails and guardrail features such as bar table, leaning signage, leaning wood.
 - i. Resin Bound Aggregate Paving.
 - j. Unit Paving.
 - k. Artificial Turf.
 - l. Decking.
 - m. Resist Structure and Footing Slab.
 - n. All Drainage components including but not limited to area drains and pipe runs.
 - o. All Irrigation components including but not limited to sprinklers, mainlines, drip lines, and valve boxes.
 - p. Urban Amenity Resist Structure Metal Top.
 - q. Planting
 - r. Shade Trellis and Shade Canopy elements.
 - s. Fencing
 - t. Pedestrian Bridge and Bridge Columns
- E. Certification for each welder for type of metal and welding process being used.
- F. Statement of qualifications for fabricators, installers, and welders.
- 1.08 QUALITY ASSURANCE
- A. Comply with the requirements specified in Section 014300.
 - B. Bench and planter fabricator: A company who specializes in the fabrication of site furnishings including the use of wood and metal systems. The firm is to have the ability to provide service in house or can provide a coordinated effort with one company

overseeing the design, documentation, and fabrication. Fabricator is to have a minimum of 10 years experience manufacturing similar products and will be responsible for the coordination, documentation, construction fabrication.

1. Welding Qualifications: As per Section 055001.
- C. Wood Boards: As per Section 062013.
- D. Workmanship: Perform work in accordance with the best standards of practice using workers experienced in the type of work specified.
- E. Mock-ups: Provide mock-up of each type of installation using approved materials and specified methods of installation. Mock-ups are constructed to verify selections made under sample submittals; to demonstrate aesthetic effects and, where indicated, qualities of materials and execution; to review coordination, testing, or operation; to show the interface between materials, and to demonstrate compliance with specified installation tolerances. Mock-ups are for evaluation of application workmanship and determine the standard for all work under the scope of work will be judged. Obtain Construction Manager and Landscape Architect approval of mock-up prior to start of installation of future work.
1. General:
 - a. Do not proceed with work until the mock-up has been reviewed and accepted by Construction Manager.
 - b. Provide a mock-up of each type, pattern, and installation per method for approval.
 - c. Mock-up located within the finish work of construction is not allowed unless approved by Construction Manager.
 - d. Accepted mock-up area may remain on site and shall be the standard for performance of the installation.
 - e. Coordinate with Mock-up requirements of other sections for interface with items such as and not limited to concrete paving, unit paving, resin bound aggregate paving, artificial turf, guardrails, planting, light poles, and walls.
 - f. All Mock-ups are subject to final approval. If rejected contractor to provide additional mock-ups at no additional cost. If any specific aspect of a mock-up is not conforming to the approved mock-up drawing layout, the Contractor to fix or redo the submittal at no additional cost.

2. Mock-ups are not samples and are to be fully complete showing all aspects of work as required for review.
3. Mock-up Plan: Prior to construction of mock-up contractor to provide dimensional drawings detailing mock-up size, and items and materials that will be included in the proposed mock-up. Submit drawings for review and approval before constructing mock-up.
4. Mock-ups shall be provided by the Contractor per mock-up types listed in this Section to provide for the approval of each manufactured site specialty element in this Section including:
 - a. Bench Type 1
 - b. Barstool Seating
 - c. Plaza Planters with Wood Seat Tops
 - d. Entry Signage
 - e. Amphitheater Wood Top Seating
 - f. Metal Retaining Walls – Wall Type 2
5. Mock-up Types: Types of Mock-ups are to be reviewed and approved by Architect/Engineer.
 - a. Partial Mock-ups: Mock-ups of a segment of a part of the final fabricated element. This includes but is not limited to brackets, connections, partial panels.
 - 1) Mock-ups are to be labeled, dated and retained.
 - b. Preliminary Mock-ups: Mock-ups for Color and Finish Verification of product to be used in the final mock-up.
 - c. Final Mock-ups: Mock-ups that are constructed to provide for approval of future work.
 - 1) Off-Site Mock-ups: Mock-ups that are not part of the finish work but constructed to provide for approval for future work. An area that is constructed outside of the field of work and to be protected throughout the project. The mock-up to demonstrate the full interface of all edge and geometry conditions shown on the Contract Drawings. This mock-up once approved it shall be the standard from which the work will be judged. Off-Site mock-ups can be constructed to address either one of the following:

- a) To provide initial approval for use to judge construction of First in Place Mock-ups.
 - b) Final determination of the quality of work to serve as the basis of all work relating to the scope of construction relating to the mock-up.
 - c) To review in-progress fabrication of work that is intended to be installed on site but allows for corrections and adjustments upon review.
- 2) Review of Off-Site Mock-ups are to be located at the facility of production, or at a designated location on site that is not included as part of the area of work. The review can be done by visiting the site/facility, or at the discretion of Construction Manager, photo documentation may be allowed.
- a) Mock-ups are to be labeled, dated and retained.
 - d. First in Place Mock-ups: These are locations in the site to verify that installation is in conformance to the approved Off-site mock-up. Mock-up may be retained as a part of the finished work upon approval by Landscape Architect and Construction Manager. If mock-up is not retained, remove and dispose of mock-up prior to the completion of the project.
6. All mock-ups are subject to approval by Landscape Architect and the Construction Manager.

1.09 PRODUCT DELIVERY AND STORAGE

- A. Comply with the requirements specified in Section 016100.
- B. Delivery: Protect all materials from damage, soiling, and accumulation of moisture during delivery.
- C. Storage:
 1. Store lumber to ensure proper ventilation and drainage; protect from rain and other damage
 2. Keep boards out of sunlight until installed.
 3. Acclimate wood to local moisture levels by stacking boards on lath, or other separators of uniform thickness, to expose both faces to air immediately upon delivery.
 4. All damaged fabrications to be replaced at no cost to DEP.

- D. Maintenance Data: For cleaning and maintaining wood and metal to include in maintenance manuals.

1.10 WARRANTY

- A. General Description: In addition to manufacturer's warranties, warrant Work for a period of one year from the date of Substantial Completion for the entire Project against defects in materials and workmanship.
- B. Additional Items Covered: Warranty shall also cover the repair of damage to other materials and workmanship resulting from defects in materials and workmanship.

PART 2 - PRODUCTS

2.01 PERFORMANCE REQUIREMENTS

- A. All components of wood and metal systems are to be interconnected and fastened together.
- B. All wood slats are to be fastened with hidden attachment systems concealed from view.
- C. If exposed fasteners required for securing units are to be of the highest quality architectural appearance and tamper resistant.
- D. Bench system to be fabricated in modular segments that can be removed for replacement and repairs.
- E. If required all electrical boxes, conduits and other services are to be concealed from view.
- F. Fabrication of wood bench assembly to be Shop Assembled. Field fabrication and welding is not allowed unless approved by the Construction Manager.

2.02 WOOD BOARDS FOR BENCH TYPE 1, BARSTOOL SEATING, PLAZA PLANTERS WITH WOOD SEAT TOPS, ENTRY SIGNAGE, AMPHITHEATER WOOD TOP SEATING

- A. Per Section 062013

2.03 METALS FOR BENCH TYPE 1, BARSTOOL SEATING, PLAZA PLANTERS WITH WOOD SEAT TOPS, ENTRY SIGNAGE, AMPHITHEATER WOOD TOP SEATING

- A. Per Section 055001

PART 3 - EXECUTION

3.01 EXAMINATION

- A. Examine areas and conditions, with Installer and Construction Manager present, for compliance with requirements for a correct and level finished grade, mounting surfaces, installation tolerances, and other conditions affecting the performance of the Work.
- B. Proceed with installation only after unsatisfactory conditions have been corrected.

3.02 INSTALLATION, GENERAL

- A. Install fabricated units in accordance with reviewed submittals, approved mock-up, and referenced standards.
- B. Cut, drill, and fit as required for installation.
- C. Set work accurately in location, alignment, and elevation; plumb, level, and true; and free of rack; measured from established lines and levels.
- D. Prevent scratching of adjacent items during installation.
- E. Adjust items prior to securing in place so as to ensure proper matching of components and correct alignment.

3.03 ADJUSTMENT AND TOUCH-UP

- A. Inspect installed work and correct deficiencies.
- B. Restore finishes damaged during installation and construction period so that no evidence of correction work remains.
- C. Return items that cannot be refinished in the field to the shop. Make the required alterations and refinish the entire unit, or provide new units.

3.04 CORRECTION AND REPAIR

- A. Non-conforming, damaged, and defective work must be brought into conformance with the Contract Documents. Correct and repair as necessary, without limitation, including arranging all correction and repair work and paying all correction and repair costs, until accepted in writing by the Construction Manager.
- B. Corrective and repair work must be performed in conformance with a correction and repair plan submitted to and accepted in writing by the Construction Manager before correction or repair work begins. At a minimum, correction and repair plans must include.

1. Written descriptions of non-conforming, damaged, and defective work;
 2. Supporting sketches, diagrams, photographs, and other visual depictions of non-conforming, damaged, and defective work; and
 3. Similar written descriptions and visual depictions of Contractor-proposed corrections and repairs.
- C. Remove and replace work that cannot be corrected or repaired to the Construction Manager's acceptance at no cost to the DEP.

3.05 CLEANING

- A. Comply with the requirements of Section 017423.
- B. Cleaning Work: Clean spills, stains, soiling, overspray, and fallout from adjacent surfaces.
- C. As installation is completed, wash thoroughly using clean water and soap or mild cleaners per manufacturer's recommendation; rinse with clean water.
- D. Use cleaning materials, equipment, and accessories supplied, and means, methods, techniques, and procedures required, recommended, or accepted by the manufacturer.
1. Do not use cleaning materials or procedures known to change, or that might change, the appearance of exposed finishes or adjacent surfaces; or cause deterioration or damage to exposed finishes or adjacent surfaces.
 2. Do not use acid solution, steel wool, or other harsh abrasives.
 3. Protect adjacent surfaces not being cleaned from staining, deterioration, damage, or other detrimental effects caused by cleaning.
 4. Arrange and pay costs without reimbursement from DEP for removing and replacing work that cannot be cleaned to the Construction Manager's acceptance.
- E. If stain remains after washing, remove finish and restore in accordance with NAAMM/NOMMA Metal Finishes Manual as per Section 055001.
- F. Waste Management: After completing the work of this specification section, leave work areas free from debris, waste, scrap, equipment, tools, and other items.
- G. Remove soil and foreign matter from furnishing and keep clean until the DEP accepts the landscape maintenance period.

3.06 PROTECTION

- A. Protect Bench Boards from damage and staining by covering with tarp or fabric until Final Completion.
- B. Do not allow equipment or material storage or staging on bench boards.

3.07 CONTRACT CLOSEOUT

- A. Provide in accordance with Section 017700.

END OF SECTION 323900

NO TEXT ON THIS PAGE

SECTION 328400 - PLANTING IRRIGATION

PART 1 - GENERAL

1.01 RELATED DOCUMENTS

1.02 SUMMARY

- A. This Section specifies the design, engineering, installation, and testing of the entire automatic irrigation system including piping, fittings, sprinkler heads, and accessories.
 - 1. Piping and fittings
 - 2. Valves and sprinklers/emitters
 - 3. Control system
 - 4. Control wire
 - 5. Testing
 - 6. Excavating and back filling irrigation system work
 - 7. Pipe sleeves

1.03 PAYMENT

- A. No separate payment shall be made for performing any Work required under this Section. All costs for Work required by this Section shall be included in the applicable Urban Amenities lump sum, as set forth in Section 012901.

1.04 DEFINITIONS

- A. **Distribution Uniformity:** A measure of how efficiently sprinklers apply water derived by dividing lower quarter of average applications by all average applications, as defined by the Irrigation Association, www.irrigation.org.
- B. **Dripline (dripper line):** Polyethylene tubing with pressure compensating, self-flushing emitters manufactured in-line.
- C. **Laterals:** Pipe downstream of remote-control valve assemblies, not pressurized when lateral is not supplying water to landscape.
- D. **Main (mainline):** Pipe continuously pressurized upstream of remote-control valves.
- E. **Supply Header:** The part of the lateral line serves as connector (manifold) for driplines.

- F. Exhaust Header: The connecting line (manifold) that connects driplines on terminal ends and is also connected to a flush/test valve.

1.05 RELATED SECTIONS

- A. General Conditions Article 4.7 – Shop Drawings and Other Submittals
- B. General Conditions Article 8 – Close-out
- C. Section 012901 – Measurement and Payment
- D. Section 014300 – Quality Requirements
- E. Section 016100 – Control of Material
- F. Section 017423 – Cleaning Up
- G. Section 017700 – Contract Closeout
- H. Section 017823 – Operation and Maintenance Data
- I. Section 312200 – Excavation and Fill
- J. Section 331000 – Water Utilities
- K. Section 335000 – Gas Utilities
- L. Section 337000 - Electric Utilities
- M. Section 338000 – Telephone Utilities
- N. Section 338101 – Communication Utilities

1.06 SUBMITTALS

- A. Submit the following in accordance with General Conditions Article 4.7.
 - 1. Shop drawings showing layout of irrigation system. Indicate the location of other site utilities with close proximity to irrigation system. Indicate size of all piping. Indicate control valve wiring routing paths, wire splice locations, and all controller system component locations. Include dimensions and orientation of surface appurtenances, as location is critical in many areas.
 - 2. Controller Manual and Operation Schedule.
 - 3. Manufacturer's product data.

4. Test data: Submit results of field quality control tests.
5. Operations and maintenance data. Describe procedures for the following: Pressure and leak testing; flushing and disinfection; seasonal procedures; valve exercising, operations and maintenance; and other data that will significantly affect operations and ensure systems maintenance. Submit written operation and maintenance instructions to include in operation and maintenance manuals.

1.07 QUALITY ASSURANCE

- A. Comply with the requirements of Section 014300.
- B. Installer Qualifications: A qualified irrigation Installer whose work has resulted in successful establishment of plants.
 1. Experience: Eight years' experience in landscape installations similar in scope and size to Project. Include list of similar projects completed by Installer demonstrating Installer's capabilities and experience. Include project names, addresses, and year completed, and include names and addresses of owners' contact persons
 2. Personnel Certifications: Installer's full time field supervisor shall have certification as Certified Irrigation Contractor from the Irrigation Association.
- C. Preinstallation Conference: Conduct conference at Project site.

1.08 DELIVERY, STORAGE AND HANDLING

- A. Comply with the requirements of Section 016100.
- B. Protect valves during transport and storage against damage, rust, and corrosion.
- C. Pipes and Fittings: Protect from entrance of dirt and debris. Protect plastic piping from direct sunlight. Store to prevent sagging and bending.
- D. Deliver irrigation system components in manufacturer's original undamaged and unopened containers with labels intact and legible.
- E. Deliver plastic piping in bundles, packaged to provide protection of pipe. Prevent pipe damage and to prevent entrance of dirt, debris, and moisture.

1.09 COORDINATION

- A. Coordinate work with other trades.
- B. Known underground and surface utility lines are indicated on the utility's drawings. Obtain line locations.

- C. Protect existing improvements including walls, paving, lighting, trees, plants, curbs and edging, lawns, and other features designated to remain.
- D. Promptly notify Construction Manager of any damage to adjacent facilities caused by irrigation system work operations. Repair damage as directed by the Construction Manager. Cost of repairs is at Contractor's expense.
- E. Promptly notify the Construction Manager of unexpected sub-surface conditions.
- F. Contractor is ultimately responsible for providing 100 percent system coverage on irrigated portions of Project site.
- G. Maintain the site in a clean, safe condition.
- H. Refer to the appropriate Section regarding the interruption of existing utilities or services if required.

PART 2 - PRODUCTS

2.01 IRRIGATION MATERIALS

- A. Provide only new materials, without flaws or defects and of the highest quality of their specified class and kind to be provided by an authorized Product Distributor. Product distributors will be asked to submit their factory authorizations to sell and service all components that they provide.
- B. Main Lines and Lateral Lines: Polyvinyl Chloride Pipe (PVC): ASTM D2241, rigid, unplasticized PVC, extruded from virgin parent material. Provide pipe homogeneous throughout and free from visible cracks, holes, foreign materials, blisters, wrinkles, and dents.
 - 1. SDR 21 PVC plastic pipe 1120 or 1220, conforming to ASTM D 2241, with a minimum pressure rating of 200 psig.
 - 2. Pipe Identification: Mark PVC plastic pipe continuously and permanently with the following information: Manufacturer's name, pipe size, type of pipe and material, SDR number, ASTM number, and NSF seal.
 - 3. Plastic Pipe Fittings: ASTM D2241 schedule 40 PVC molded fittings suitable for solvent weld connections. Fittings made of other materials are not permitted. Saddle and cross fittings not permitted. PVC molded fittings manufactured of same material as pipe. Fittings shall be suitable for one of the following:
 - a. Solvent weld for pipe DN50 (2 in.) or less.

- b. Ring-tite seal conforming to ASTM D 2466 or BS EN 1452-3:2000 for pipe sized 3 inch and greater.
- c. Threaded connections to be Schedule 40, minimum, except where called out as Schedule 80 in plans and details.
- 4. Use ductile iron fittings with restraints on all pipe 3 inch and greater in size. Use plastic Schedule 40 fittings on all gasket pipe less than 3 inches diameter. Use glue end fittings on all bell end PVC.
- 5. Use ductile iron restraints on all 45- and 90-degree elbows on pipe 3 inches and larger.
- C. Detector Tape: Solid aluminum foil core running full length and width of tape, and encased in protective, high visibility, color coded, inert plastic jacket.

2.02 VALVES

- A. Master Valve/Flow Sensor: As shown on irrigation plan.
 - 1. The Master Valve/Flow Sensor (hydrometer) shall have a maximum working pressure of 140 PSI.
 - 2. The flow meter shall have an accuracy of +/- 2 percent within the required flows of the system.
- B. Drip Lateral Remote Control Valve Assembly: As shown in plans and installation details. Assembly must include a glass filled nylon body valve, a pressure regulator matching dripline manufacturer's pressure requirements, a filter matching dripline manufacturer's filtration requirements and an isolation valve (ball valve) upstream of and sized identically to control valve.
- C. Quick Coupling Valve: As specified on plans and details. Install at the ends of mainlines and as shown on plan.
- D. Isolation valves: As shown on irrigation plan.

2.03 SPRINKLERS & EMITTERS

- A. Driplines:
 - 1. Subsurface driplines shall be as manufactured by Hunter, Inc., Irrigation King, Inc., DIG Corporation, or approved equal with emitter spacing to be 12 inches. If changes in emitter flows are approved installer must recalculate zone flows and adjust as necessary.

2. Row spacing in planters shall be 18 inches.

2.04 AUTOMATIC CONTROL SYSTEM

A. The controller shall be able to operate:

1. Up to 100 zones along a two-wire path and/or a conventional wire path
2. Up to 20 moisture sensors
3. Up to 8 temperature sensors, which monitor, and control program operation based on temperature thresholds
4. Up to 7 normally open or normally closed event device inputs
5. Up to 7 normally open or normally closed master valves and/or pump starts for the entire system
6. 3 water sources and 3 associated flow sensors or meters
7. Up to 110 device loads on the two-wire path
8. 1, 2, and 4 station decoders = ½ load
9. 12 to 24 station powered decoder = 2 loads
10. Soil moisture sensor = 1 load
11. Flow decoder = 3 loads
12. Event device = 1 load
13. Up to 30 completely independent programs
14. Up to 15 solenoids concurrently over two-wire
15. Up to 2 typical solenoids per 12 station powered decoder or up to 4 typical solenoids per 24 station powered decoder over conventional wire plus 2 additional solenoids using the specially designated ports

B. The controller shall display on-screen help. The on-screen help shall be available in both English and Spanish. The help text language shall be user-configurable.

C. The operator shall be able to establish 3 levels of security for users of the controller: Operator, Programmer, and Administrator.

- D. The controller shall be capable of managing 40 programs, including up to 8 start times per program, with 10 overlapping and stacking programs.
- E. The controller shall allow run times for zones from 5 seconds to 24 hours.
- F. The controller shall be able to adjust seasonal water budget from 10 percent to 200 percent by program.
- G. The controller shall allow an operator to enable or disable each zone.
- H. The controller shall allow an operator to set a “water window” by program on a per hour basis for each day of the week, which suspends watering beyond a set time and resumes watering when another window opens.
- I. The controller shall allow a program to be started by the following conditions:
 - 1. Moisture percent
 - 2. Temperature value
 - 3. Event decoder contacts open/closed
 - 4. Date and time
- J. The program shall be capable of using the following schedules:
 - 1. Day intervals in even days
 - 2. Odd days
 - 3. Odd days excluding the 31st
 - 4. User defined interval
 - 5. Custom 7-day calendar
- K. The controller shall be able to irrigate in Timed, Soil Moisture based, Event based.
- L. The controller shall display a 31-day soil moisture history graph.
- M. The controller shall display all start, pause, and stop events in message screens that are accessible from the main screen. The system displays one message for each condition, and the user can clear each message.
- N. The controller shall display high flow alerts, learn flow failure messages, wire faults, as well as other operating conditions.

- O. The controller shall display messages generated from diagnostic tests initiated by the controller and by the user.
- P. The controller's main screen shall be able to display water usage, soil moisture graphs, design flow or actual flow, two-wire current, program reports, and zone status (shown as an icon representing unassigned, idle, waiting, watering, soaking, paused, disabled, and message) without affecting any active programs.
- Q. The controller shall be able to log data collected from each flow meter, moisture sensor, temperature sensor, and zone run time.
- R. The controller shall have the ability to perform Intelligent Soak Cycles™ to prioritize cycles for zones that have already started to water over zones that have not started.
- S. The controller shall support 3 water sources and 3 associated flow sensors or meters.

2.05 MOISTURE SENSOR

- A. The controller shall support up to 20 individual soil moisture sensors.
- B. The controller shall override a programmed number of cycles or day interval when it detects a soil moisture reading that exceeds the assigned shut-off value.
- C. The controller shall override a programmed number of cycles or day interval when it detects a soil moisture reading that exceeds the assigned shut-off value.
- D. The controller shall provide a moisture limit that is accurate within ± 3 percent.

2.06 SYSTEM BACKUPS

- A. The controller shall be able to export all data and load all programming information to and from a USB flash drive.
- B. All programming shall be saved in non-volatile memory.
- C. The controller shall save event logs immediately to non-volatile memory.

2.07 DIAGNOSTICS

- A. The controller shall have the ability to reprogram the solenoid drive current of the decoder from the controller without uninstalling or removing the decoder from the field.
- B. The controller shall be able to detect and report a "two-wire over current."
- C. The controller shall be able to read and report the current of the two-wire during normal running conditions.

- D. The controller shall be able to test each individual zone and display:
 - 1. Two-wire voltage drop
 - 2. Valve voltage
 - 3. Current
 - 4. Decoder serial number

2.08 CONTROL WIRING

- A. Control wiring shall be as specified by the controller manufacturer.
- B. All control wire splices below grade, shall be made waterproof with correctly sized wire splice connectors, made for direct burial and as recommended by controller manufacturer.
- C. Electrical Components: Listed and labeled as defined by NFPA 70 by testing agency approved by Architect/Engineer.

PART 3 - EXECUTION

3.01 INSPECTION

- A. Examine final grades and installation conditions. Verify that field measurements are as shown on approved Shop Drawings. Do not start irrigation system work until unsatisfactory conditions are corrected.
- B. Verify the location of utilities, plant materials, shrub bed lines and tree lines. No irrigation lines are to be routed within 5 feet of any tree on the Project site. Contractor is responsible for coordinating the location of all trees with landscape subcontractor.
- C. Verify that required utilities are available, in correct locations and ready for use.
- D. Commencement of installation means Installer accepts the existing conditions.
- E. Contractor must provide one experienced on-site foreman or supervisor subject to approval of Construction Manager, who must be on site at all times when a crew is working.
- F. Inspections will be scheduled at the pre-construction meeting.

3.02 EARTHWORK

- A. Refer to Section 312300 for excavating, trenching, and backfilling.

- B. Install warning tape directly above pressure piping, 12 inches below finished grades, except 6 inches below subgrade under pavement and slabs.
- C. Install each pipe and each wiring bundle in separate sleeves under sidewalks, roadways, and parking lots.
 - 1. Install sleeves before pavement is installed where possible.
 - 2. Install piping sleeves by boring or under existing paving unless not readily feasible.
- D. Provide minimum cover over top of underground irrigation main piping according to the following:
 - 1. Irrigation Main Piping: Minimum depth of 18 inches from finished grade to top of pipe or sleeve.
 - 2. Irrigation Lateral Piping: Minimum depth of 12 inches from finished grade to top of pipe.
 - 3. Irrigation Valves: Provide a clearance of 3 inches minimum, between top of valve assembly and valve box cover.
- E. Proceed with installation only after unsatisfactory conditions have been corrected.

3.03 PREPARATION

- A. Inspection of Site: Contractor shall become acquainted with the on-site condition present immediately prior to installation of irrigation system. Prior to excavation, utility companies shall be notified in accordance with local codes and ordinances.
- B. Place sleeves as necessary for installation of piping and control wire. All piping under walks and roadways shall be within a Schedule 40 PVC or sleeves 2 sizes larger than the pressure pipe.
- C. Identify proposed sprinkler and supply header locations using stakes prior to excavation for approval by Construction Manager.

3.04 EXCAVATION

- A. Loosen subgrade of Trench Excavation: Conform to ASTM F 690.
- B. Tree Protection: All trenching or other work under leaf canopy of any tree shall be done by hand or by other methods so that no branches and minimal root systems are damaged. Excavation shall be hand dug in all planter areas.
- C. Excavate trenches of sufficient depth and width to permit proper handling and installation of pipe and fittings.

- D. Excavate to depths required to provide 3" depth of debris free earth fill or sand bedding for piping when rock or other unsuitable bearing material is encountered.
- E. Excavate trenches and install piping and fill during the same working day. Do not leave open trenches or partially filled trenches open overnight.
- F. Valve Boxes: Set in drainage aggregate with geotextile fabric and as otherwise shown in irrigation plans and details.

3.05 INSTALLATION

- A. Piping Installation: Install underground thermoplastic piping as indicated according to ASTM D 2774 and irrigation component manufacturer's written installation instructions, unless deviations are approved on Shop Drawings by the Irrigation Designer.
 - 1. Do not install thermoplastic piping if air temperatures fall below 40 degrees F during 24-hour period prior to scheduled time for installation, or if air temperatures are forecast to fall below 40 degrees F during 24-hour period after piping installation.
 - 2. Maintain piping interiors to be free of dirt and debris. Close open ends of pipes by acceptable methods when piping installation is not in progress. Remove dirt and debris from inside and outside of pipes and fittings before assembly.
 - 3. Install piping free of sags and bends on firm, uniformly sloped subbase.
 - 4. Install groups of pipes parallel to each other, spaced to permit valve servicing.
 - 5. Install fittings for changes in piping direction and branch connections.
 - 6. Install expansion loops in control-valve boxes.
 - 7. Install piping in sleeves under parking lots, roadways, and sidewalks.
 - 8. Saw cut piping on large pipe. Use an electric miter saw, to ensure square pipe cuts. Ream cut ends of pipes and remove burrs and shavings prior to installation. Use a hand beveler on all gasket pipe cuts.
 - 9. Make plastic to plastic joints with solvent weld joints or slip seal joints. Use only solvent recommended by the pipe manufacturer. Install plastic pipe fittings in accordance with pipe manufacturer's instructions. The Contractor shall make arrangements with pipe manufacturer for all necessary field assistance.
 - 10. Make plastic to metal joints with plastic male adapters.
 - 11. Allow joints to set at least 24 hours before pressure is applied to the system.

12. Drip line spacing to be 12 inches on rows with 12 inches between emitters. Drip lines to be installed just below the mulch line with a sod staple every 36". Install all drip lines across the face of slopes in the same manner. All zone valves along slope are to be installed on a flat surface if possible.

B. Sprinklers, Controllers, Fittings, Valves, and Accessories:

1. Install fittings, valves, sprinkler heads, risers, and accessories in accordance with manufacturer's instructions, except as otherwise indicated.
2. Set sprinkler heads perpendicular to finished grades, except as otherwise indicated. Heads set along curbing are to be installed no further away from curbing than 5 inches or as shown in the details.
3. Locate sprinkler heads to assure proper coverage of indicated areas. Do not exceed sprinkler head spacing distances indicated. Divert spray from all windows and building walls.
4. Install controller in accordance with manufacturer's written instructions. Install the controller with conduit for all exposed wires.
5. Install valve access boxes on a suitable base of bricks to provide a level foundation at proper grade and to provide drainage of the access box. 1 1/2 cubic feet of pea gravel below box to be provided for drainage (see detail). The gravel shall be in place before the box is set.
6. Apply Teflon tape to all threaded connections of control valves. Plastic joint type compound is not acceptable.

C. Control Wiring:

1. Install electric control cable from controller through conduit to planted area. Use valve boxes for any necessary connections and splices. Provide conduit and coordinate with other trades in installing conduit from underground location to landscaped surface above.
2. Provide sufficient slack at site connections at remote control valves in control boxes, and at all wire splices to allow raising the valve bonnet or splice to the surface without disconnecting the wires when repair is required.
3. Label all wire in each valve box and at each controller with numbered labels. Include labels for extra wires. Include labels on each decoder's output wire to show what valve it operates.
4. Connect remote control valves for each controller independent of all other controllers.

5. Make wire connections to remote control electric valves and splices of wire in the field, using waterproof wire connectors and sealant in accordance with manufacturer's recommendations, dry splices will not be accepted. If wire splices are necessary make wire splices in accessible valve boxes 10 inches in diameter or greater.
6. Provide tight joints to prevent leakage of water and corrosion build-up on the joint.
7. When control wiring is in common trench with main line, wiring shall be below main line with 4 inches of fill dirt between pipe and wire.
8. Above-ground wire is to be installed in conduit and/or in accordance with electrical codes.
9. All materials and methods of installation shall conform to electrical codes in effect for the Project.

D. Sleeves:

1. Provide new sleeves for all locations where existing sleeves are not indicated. All sleeves shall be set no higher than main line or lateral held within. All sleeves must be perpendicular to curbs.
2. Install pipe sleeves under existing concrete or asphalt surface by boring. Obtain Construction Manager's permission before cutting existing concrete and asphalt surfaces. Where piping is shown under paved areas which are adjacent to turf areas, install the piping in the turf areas as noted above.
3. Sleeve Materials: Class 200 PVC pipe for all sizes used on this project.
4. Sleeve material for dripline under pavement shall be Class 200 PVC.

E. Flushing, Testing and Adjusting:

1. After piping and risers are installed and before sprinkler or emitters are installed, open control valves and flush out the system with full head of water.
2. Prior to back filling, test mainline for leakage for whole system by filling with water and pressurizing to 100 PSI for one hour, minimum. System is acceptable if no leakage or loss of pressure occurs during test period. Irrigation designer or Construction Manager must view depth of all pipes, thrust block installation, quality of fill material, and quality of trench cut before trenches can be covered. It is the responsibility of Contractor to give the Construction Manager advance notice of trenching operations. PVC that is covered without the Irrigation Designer's approval will not be accepted until it is excavated and approved by Construction Manager. This test will be enforced by the Construction Manager.

3. Perform system testing upon completion of each section. Make necessary repairs and re-test repaired sections as required.
4. Adjust sprinklers and emission devices, except those intended to be mounted aboveground, so they will be flush with finish grade or as shown in irrigation details.
5. Adjust sprinklers and emission devices after installation for proper and adequate distribution of the water over the coverage pattern. Adjust for the proper arc of coverage if sprinklers are used.
6. Adjust automatic control valves to provide flow rate at rated operating pressure required for each lateral.
7. Test and demonstrate the controller by operating all programs, day, hour, and station selection features as required to automatically start and shut down irrigation cycles to accommodate plant requirements and weather conditions.

F. Dripline:

1. Provide drip tubing to all plant material served by drip irrigation system in accordance with manufacturer's guidelines. Become thoroughly familiar with drip tubing manufacturer's design guide and specifications
2. Verification of plant material quantities and number of emitters per valve station is the responsibility of the Contractor.
3. Drip irrigation lines may be shown on irrigation plan within hardscape for clarity. Install all piping in landscape planting areas per design intent.
4. Install all drip tube and pipe within PVC sleeve when routing under paved surfaces or through planter walls.
5. Refer to planting legend for plant material names, abbreviations, specific sizes, on-center spacing and additional information.
6. Provide one at least one (1) flush/test-valve assembly in each planter and/or exhaust manifold as recommended by tubing manufacturer. Locate flush/test-valve assembly boxes adjacent to planting borders or paving edges for maintenance convenience if possible.
7. The maximum velocity through lateral pipe & dripline must not exceed 5 feet per second. Due to the schematic nature of the drip irrigation layout the contractor is responsible to verify flows through all drip zone laterals and valves.

8. A single dripline tube or combination of several dripline tubes originating from one dripline tube, must not exceed the manufacturer's specified length for the specific emitter used.
 9. Thoroughly flush laterals before making connections and after making connections, following manufacturer's recommendations.
 10. Exhaust headers made of dripline may be substituted for PVC headers provided the water demand served by the header is less than 5 GPM.
 11. Observe and record operating pressure at each flush/test valve.
 12. Approximate dripline grid placement is shown on plan. Contractor to make all necessary on-site adjustments to match existing conditions and planting locations.
 13. For all subsurface drip application, use only dripline with emitters designed specifically for below grade installation.
 14. Install dripline grid in planting beds as shown in installation detail in irrigation plan, spacing as indicated on plan.
 15. Install shutoff valve and flush valve in valve box as shown on plan at finish grade.
 16. At time of installation record pressure at each flush/test valve. Record pressures for each location to be provided to Construction Manager.
- G. Automatic Control System: Install in accordance with approved control design and manufacturer's recommendations. Do not attach sensors in conspicuous locations such as building facades.
1. Electrical power outlet near the controller will be provided by Contractor.
 2. Make final electrical connection to automatic controller. All work to be completed in accordance with applicable electric codes.
- H. Warning Tapes: Arrange for installation of continuous, underground, detectable warning tape over underground piping, during backfilling of trenches.
- I. Attach a permanent valve number identification tag to each remote-control valve and engrave the same number on the valve box lid. Mark master valve "MV", flow sensor "FS", flush valve "FV", etc.
- J. Backfilling: Provide minimum cover over top of underground piping according to the following:
1. Irrigation Main Piping: Minimum depth of 18 inches to top of pipe.

2. Lateral (Circuit) Piping: Minimum depth of 12 inches to top of pipe.
3. Sleeves: Minimum depth of 18 inches to top of sleeve.

3.06 FIELD QUALITY CONTROL

- A. Test Piping and Valves to verify conformance to design water pressure requirements prior to backfill of trenches.
- B. Pressure test system mainline at 100 PSI for one hour minimum as details above.

3.07 STARTUP SERVICE

- A. Engage a control system factory-authorized service representative to perform startup service.
- B. Verify that controllers are installed and connected according to the Contract Documents.
- C. Verify that electrical wiring installation complies with manufacturer's submittal and installation requirements in Division 26 Sections.
- D. Complete startup checks according to manufacturer's written instructions.
- E. The Contractor shall turn over to the Construction Manager; two each of all operating keys and servicing tools needed for complete access, adjustment, and repair of all irrigation system components. This includes specialized tools required for complete disassembly of each sprinkler and valve.
- F. The Contractor shall turn over to the Construction Manager drip system pressure logs.

3.08 ADJUSTING

- A. Adjust settings of controllers.
- B. Adjust automatic control valves to provide flow rate of rated operating pressure required for each sprinkler circuit (lateral).
- C. Adjust sprinklers and emission devices so they will not be above finish grade.

3.09 CLEANING

- A. Thoroughly flush dirt and debris from piping before installing sprinklers and other devices.

3.10 FINAL ACCEPTANCE

- A. Test and demonstrate to the Construction Manager and NJDEP the satisfactory operation of the system free of leaks.
- B. Instruct the NJDEP's designated personnel in the operation of the system including adjustment of sprinklers, controller(s), and valves.
- C. Provide one (1) eight-hour day of instruction to the City of Hoboken's maintenance personnel by qualified (qualified is subject to Architect/Engineer approval) representative on operation of all components.
- D. Upon Final Acceptance the City of Hoboken will assume operation of irrigation system.
- E. Provide Architect/Engineer with all manuals for products used in the Project, as noted in General Conditions Articles 4.7 and 8, and Section 017823.
- F. Provide Construction Manager with 1 key for every three manual valves used in the Project. More than one type of valve may require more than one type of key.
- G. Final Acceptance will be based on system adherence to requirements of the Drawings and Specifications. In any area where the requirements are not met, Contractor shall completely reinstall that area to meet the requirements of the Contract Documents.

3.11 GUARANTEE

- A. Refer to General Conditions Article 8.
- B. Contractor shall guarantee all workmanship covered by the specifications to be free of defects for a period of one (1) year from Date of Project Substantial completion. Replace any part of parts found to be defective within the guarantee period at no cost to the Project, except repairs or replacement necessitated by damage caused by other trades. Materials, fixtures, and equipment are to be warranted for one (1) year from installation date. Warranty must include computer hardware and software. This guarantee is to be certified in writing by factory representatives.
- C. Backfilling of all excavation shall be guaranteed. If, at any time during the 1 year of the guarantee period, trenches or heads should settle, the Contractor shall repair any settling at no cost to the DEP.
- D. Instruct the City of Hoboken's designated personnel in general operation, proper seasonal procedures, and review maintenance procedures.

3.12 CLEANING

- A. Comply with the requirements of Section 017423.

- B. Perform cleaning, including sweeping of sidewalks and washing streetscapes during installation each day of the work and upon completion of the work. Remove from site all excess materials, soil, debris, and equipment. Repair damage resulting from irrigation system installation.

3.13 DISPOSAL OF WASTE MATERIAL

- A. Comply with the requirements of Section 017423.
- B. Remove surplus soil and waste material including excess subsoil, unsuitable soil, trash, and debris and legally dispose of them off project site.
- C. Stockpile, safely haul from Project site, and lawfully dispose of irrigation system construction waste materials, including piping cutoffs, unsuitable excavated materials, and construction debris.

3.14 CONTRACT CLOSEOUT

- A. Comply with the requirements of Section 017700.
- B. Provide irrigation system Record Drawings:
 - 1. Legibly mark Record Drawings to record as-built system construction.
 - 2. Indicate a measured distance triangulated to locate each installed valve-automatic, manual, quick-coupling type and a location of mainline every 100 feet.
 - 3. Identify field changes of dimensions and details, and changes made by Change Order, if any.
 - 4. Submit three (3) copies of Record Drawings to the Construction Manager on base drawings provided by the Architect/Engineer. Include a drawing file for the Record Drawings in AutoCAD. When requested by Construction Manager, provide interim AutoCAD drawing file. This may be requested periodically.
 - 5. As-builts shall also indicate control valve wiring routing paths, wire splice locations and controller locations.
 - 6. Include an Excel spread sheet and associated files showing irrigation programs, zones, gallons per minute of each zone, type of zone (turf or shrub) type of head, run time, number of days, etc. Include spring, summer, and fall baseline programs. One hard copy must be clear plastic laminated.

END OF SECTION 328400

SECTION 329113 – SOIL PREPARATION AND FINISH GRADING

PART 1 - GENERAL

1.01 DESCRIPTION

- A. Provide on-grade soil preparation, topsoil placement, soil amending, and finish grading work as indicated and in compliance with Contract Documents.
- B. Section includes planting soils specified by composition of the mixes.

1.02 PAYMENT

- A. No separate payment shall be made for performing any Work required under this Section. All costs for Work required by this Section shall be included in the applicable lump sum(s), unit price(s), or allowance(s), as set forth in Section 012901.

1.03 DEFINITIONS

- A. AAPFCO: Association of American Plant Food Control Officials.
- B. Backfill: The earth used to replace or the act of replacing earth in an excavation. This can be amended, or unamended soil as indicated.
- C. CEC: Cation exchange capacity.
- D. Compost: The product resulting from the controlled biological decomposition of organic material that has been sanitized through the generation of heat and stabilized to the point that it is beneficial to plant growth.
- E. Duff Layer: A surface layer of soil, typical of forested areas, that is composed of mostly decayed leaves, twigs, and detritus.
- F. Imported Soil: Soil that is transported to Project site for use.
- G. Layered Soil Assembly: A designed series of planting soils, layered on each other, that together produce an environment for plant growth.
- H. Manufactured Soil: Soil produced by blending soils, sand, stabilized organic soil amendments, and other materials to produce planting soil.
- I. NAPT: North American Proficiency Testing Program. An SSSA program to assist soil-, plant-, and water-testing laboratories through interlaboratory sample exchanges and statistical evaluation of analytical data.

- J. Organic Matter: The total of organic materials in soil exclusive of undecayed plant and animal tissues, their partial decomposition products, and the soil biomass; also called "humus" or "soil organic matter."
- K. Planting Soil: Existing, on-site soil; imported soil; or manufactured soil that has been modified as specified with soil amendments and perhaps fertilizers to produce a soil mixture best for plant growth.
- L. RCRA Metals: Hazardous metals identified by the EPA under the Resource Conservation and Recovery Act.
- M. SSSA: Soil Science Society of America.
- N. Subgrade: Surface or elevation of subsoil remaining after excavation is complete, or the top surface of a fill or backfill before planting soil is placed.
- O. Subsoil: Soil beneath the level of subgrade; soil beneath the topsoil layers of a naturally occurring soil profile, typified by less than 1 percent organic matter and few soil organisms.
- P. Surface Soil: Soil that is present at the top layer of the existing soil profile. In undisturbed areas, surface soil is typically called "topsoil"; but in disturbed areas such as urban environments, the surface soil can be subsoil.

1.04 REFERENCES

- A. American Society for Testing and Materials (ASTM):
 - 1. ASTM D422 Standard Test Method for Particle-Size Analysis of Soils.
 - 2. ASTM D1557 Standard Test Method for Laboratory Compaction Characteristics of Soil Using Modified Effort.
 - 3. ASTM D2434 Standard Test Method for Permeability of Granular Soils (Constant Head).
 - 4. ASTM D5268 Standard Specification for Topsoil Used for Landscaping Purposes.
- B. Environmentally Friendly References:
 - 1. Organic Materials Research Institute (OMRI) – Generic Materials List, <https://www.omri.org/omri-lists>.
 - 2. US Composting Councils USCC Seal of Testing Assurance program (STA), www.compostcouncil.com.

1.05 RELATED SECTIONS

- A. General Conditions Article 4.7 – Shop Drawings and Other Submittals.

- B. Section 012901 – Measurement and Payment.
- C. Section 014300 - Quality Requirements.
- D. Section 016100 - Control of Materials.
- E. Section 017423 – Cleaning Up
- F. Section 017700 - Contract Closeout.
- G. Section 329300 – Planting
- H. Section 329400 – Planting Accessories
- I. Requirements from the following sections also apply to this Section:
 - 1. Section 329123 – Structural Soil
 - 2. Section 329700 – Landscape Maintenance

1.06 SUBMITTALS

- A. Submit the following in accordance with General Conditions Article 4.7.
- B. Product Data: For each type of product indicated.
 - 1. Include recommendations for application and use.
 - 2. Include test data substantiating that products comply with requirements.
 - 3. Include sieve analyses for aggregate materials.
 - 4. Material Certificates: For each type of imported soil and soil amendment and fertilizer before delivery to the site, according to the following:
 - a. Manufacturer's qualified testing agency's certified analysis of standard products.
 - b. Analysis of fertilizers, by a qualified testing agency, made according to AAPFCO methods for testing and labeling and according to AAPFCO's SUIP #25.
 - c. Analysis of nonstandard materials, by a qualified testing agency, made according to SSSA methods, where applicable.
- C. Samples: Provide 2 samples of each of the following materials in 0.25 cubic foot clear plastic bags:
 - 1. Topsoil.
 - 2. Structural Soil
 - 3. Mulch.

4. Composted soil conditioner.
 5. Other soil amendments such as fertilizer and minerals stating the source, physical, and chemical composition and quantity available.
- D. Soil Test Reports: Submit testing of soils anticipated for use on the project in accordance with paragraph 1.08 Soil Tests.
- E. Soil Test Placement Logs: Submit records of the source of all imported soils for planting operations that clearly depict soil import locations on plan drawings with records of delivery and associated soil testing of delivered material.
- F. Certification: Furnish a certificate with each delivery of bulk material, including topsoil, stating its source, quantity, type of material furnished and that such item or material conforms to specification requirements.

1.07 QUALITY ASSURANCE

- A. Comply with the requirements specified in Section 014300.
- B. Topsoil Installer: Company specializing in installing and amending topsoil specified in this Section with a minimum of eight years documented experience in performing landscape work of comparable size, scope, and dollar value.
- C. Provide at least one qualified foreman who shall be present at all times during the execution of this portion of the work, who shall be thoroughly familiar with the type of materials being installed and the proper materials and methods for their installation, and who shall direct all work performed under this Section.
- D. The Contractor shall be responsible for providing fine grading that assumes a natural and pleasing appearance as directed by the Construction Manager. The finished grade at the uphill side of all retaining walls shall be within 2 inches of the top of the wall. Backfill or topsoil may be required to bring the planting areas to suitable planting level.
- E. Soil compaction testing: following installation or modification of soil, test soil compaction with a penetrometer.
1. Maintain at the site at all times a soil cone penetrometer with pressure dial and a soil moisture meter to check soil compaction and soil moisture.
 2. Prior to testing the soil with the penetrometer check the soil moisture and penetrometer readings in the mockup soils. Penetrometer readings are impacted by soil moisture and excessively wet or dry soils will read significantly lower or higher than soils at optimum moisture.
 3. The penetrometer readings shall be within 20 percent plus or minus of the readings in the approved mockup when at similar moisture levels.

1.08 SOILS TESTS

- A. To ensure a suitable growing medium for plants, the Contractor shall employ the services of a certified agronomic soils testing laboratory to perform soil testing of topsoil. The Contractor is responsible for absorbing agronomic soil testing costs as part of the contract. Testing shall be done on existing site soils identified for topsoil as well as all imported material and amended materials.
- B. Testing Laboratory: The Contractor shall use a single testing laboratory for all project soil testing. Laboratory as part of their work is to provide all testing and recommendations for amendments of planting soils for the project. The use of multiple testing laboratories is not allowed.
1. During the evaluation of all testing reports and follow up analysis the contractor is to authorize full access to Architect/Engineer to contact the testing laboratory for consultations regarding reports and recommendations provided by the laboratory.
 2. Contractor shall use the following laboratory:
 - a. Rutgers Soil Testing Laboratory
Rutgers, The State University of New Jersey
57 US Highway 1 njaes.rutgers.edu/soil-testing-lab/
New Brunswick, NJ 08901-8554
Telephone: 848.932.9295
Web: <https://njaes.rutgers.edu/soil-testing-lab/>
 - b. Cornell University Soil and Corp Sciences Section
 - c. Penn State College of Agricultural Sciences
 - d. Or approved equal
- C. Perform import topsoil sampling and testing at three stages in the process:
1. Prior to acceptance of material:
 - a. Topsoil – Complete Analysis and bulk density as described under paragraph 1.08E.
 - b. Provide a test of a blended sample from a single known source. The sample that will be tested will take representative samples throughout the source and frequency of samples to equaling 10,000 square feet of the proposed planting area. The analysis of a single sample taken from the source is not accepted.
 - c. Soils report identifying the number of samples that were taken to create a blended sample.
 2. Before shipment of material to the site. The Contractor shall test every 500 cubic yards of material before shipment. All soils are to be tested and approved before

shipment. Material that is shipped and installed without being tested will be rejected and to be removed from the site at no cost.

3. Post Installation: Complete Analysis to verify horticultural conditions and establish recommendations for the use of natural non-synthetic materials for maintenance practice.
 - a. Testing to be done before substantial completion and the beginning of 90-day maintenance and final acceptance. Reports will be used for guidance during the Landscape Maintenance Period.
 - b. Provide 1 test for every 10,000 square feet of area for each soil type installed on site. If less than 10,000 square feet provide 2 tests.
4. Amendment materials shall be submitted together with the Topsoil and Import Soil Samples for testing and verification. Laboratory analysis as per specifications with specific recommendations for inclusion in this project. Recommendations shall include natural, non-synthetic fertilizers.

D. Scheduling of testing:

1. The Contractor is responsible for submitting soil samples and test results promptly so as to not impact schedule and allow appropriate time to review soil reports.
2. Provide soil analysis submittals before shipment and placement of soils.
3. Initial sample tests for approval are to be dated no more than three (3) months from the submittal date.
4. Sample testing of the import topsoil and amendments should be dated no more than 30 days from the date of delivery.

E. Complete Analysis and Recommendations; Contractor shall provide a chemical analysis report of each soil sample location at each soil test location: to include the following:

1. Test Reports: Submit certified reports for tests as described in this Section.
 - a. Mechanical gradation (sieve analysis) shall be performed and compared to the USDA Soil Classification System. Percent clay (<0.002 mm) shall be reported separately in addition to silt, sand, and gravel (SSSA/ASA, Methods of Soil Analysis, Part 4, Physical Methods, 1986, chapter 15, pgs 383-411, hydrometer method).
 - b. The silt and clay content shall be determined by a Hydrometer Test of soil passing a 2-millimeter screen.
 - c. Submit a chemical analysis performed in accordance with current ASA and UC Standards, including the following:
 - 1) pH.

- 2) Percent organic matter as determined by total organic carbon, and total nitrogen. Test samples shall be oven-dried to a constant weight at a temperature of 105 degrees C.
 - 3) Analysis for nutrient levels and toxic elements by parts per million including nitrate-nitrogen, and extractable phosphorus, potassium, magnesium, manganese, iron, zinc, copper, boron, sulfate, calcium, molybdenum, sodium, aluminum, arsenic, cadmium, chromium, cobalt, lead, lithium, mercury, nickel, selenium, silver, strontium, tin, and vanadium. Nutrient tests shall include testing laboratory recommendations for supplemental additions to soils as calculated by the amount of material to be added per volume of soils for the type of plants to be grown in the soil.
 - 4) Soluble salt by electrical conductivity of a saturated paste extract measured in millimho per cm, soluble calcium, magnesium, potassium, sodium, sulfate, chloride, nitrate, and boron
 - 5) Components of the test shall include all major nutrients: N, P, K, Ca, Mg, SO₄, Na, B, Cu, Zn, Mn, Fe,
- d. Certified reports on analyses from producers of composted organic materials are required, particularly when sources are changed and when new stockpiles are used.
 - e. Tests shall include particle size analysis of a sample including a gradient of mineral content in accordance with USDA designation.
 - f. Compost Testing: Test maturity of compost by the Solvita method as required. Also, test compost maturity by measuring the pH in a saturation extract; by measuring available aluminum, iron, and manganese; by measuring the molar: ammonium nitrate ratio and soluble organic acids with ASA/SSSA approved methods.
 - g. Determination of plant available nutrients and non-essential minerals tested by ammonium bicarbonate Diethylene Triamine Pentaacetic acid (AB DTPA) described in Methods of Soil Analysis, Part 3 Chemical Methods, Soil Science Society of America, Inc. 1996.
 - h. Saturated Hydraulic Conductivity Test - USDA Handbook Number 60, method 34b or other approved methods.
 - i. Potential hazards of impediments to plant growth from salinity, sodium, boron, impaired soil structure, or drainage.
2. All soil tests are to clearly identify reference source, location, and sample date for each sample submitted for testing.
 3. As part of the submittal for soil analysis for review by Construction Manager, the Contractor shall clearly identify the anticipated location on the site where the soil will be placed.

4. All analysis is to provide a general assessment of the soil with written recommendations to incorporate the results of the Contractor's proposed amendments for the soil with application rates for:
 - a. Tree pits
 - b. Shrub and Groundcover Beds
 - c. Lawns
 - d. Structural Soil
 - e. Hydroseeding

1.10 SOIL COMPACTION – GENERAL REQUIREMENTS

- A. Except where more stringent requirements are defined in this Section. The following parameters shall define the general description of the threshold points of soil compaction in existing, modified or installed soil and subsoil.
 1. Standard Proctor Method ASTM D 698
 - a. Units - percent maximum dry bulk density as tested by the standard proctor method. Threshold results that determine critical bulk density are the same for each soil texture. A proctor test will typically also provide results as Bulk density lb./cf dry weight.
 - b. Measurement Tool - Densitometers
 - c. Pro/cons - Moderately slow 10 minutes per test, accurate, expensive, lab test required to determine every specific soil texture's Proctor density curve, readings are impacted by soil organic matter, must hire a soil testing service.
- B. The following are threshold levels of compaction as determined by each method.
 1. Acceptable Compaction: Good rooting anticipated, but increasing settlement expected as compaction is reduced and/or in soil with a high organic matter content.
 - a. Standard Proctor Method – 75-85 percent; soil below 75 percent is unstable and will settle excessively.
 2. Root limiting Compaction: Root growth is limited with fewer, shorter and slower growing roots.
 - a. Standard Proctor Method – above approximately 85 percent.
 3. Excessive Compaction: Roots not likely to grow but can penetrate soil when soil is above field capacity.
 - a. Standard Proctor Method – Above 90 percent.

1.11 SITE CONDITIONS

- A. Notify the Construction Manager of discrepancies between Contract Drawings and Contract Sections and actual job site conditions which would affect the execution of the landscaping work. Do not work in areas where discrepancies occur until instructed to proceed by the Construction Manager.
- B. Exercise care in excavating and working near existing utilities. The Contractor shall be responsible for damages to utilities which are caused by the Contractor's operations or neglect. Check existing utility drawings for existing utility locations.
- C. Repair or replace existing improvements which are not designated for removal which is damaged or removed as a result of the Contractor's operations. When a portion of a sprinkler system must be removed, cap the remaining lines. Repairs and replacements shall be equal to existing improvements and shall match existing improvements in finish and dimension.
- D. Costs for protecting, removing, and restoring existing improvements shall be included in Contractor's Bid.

1.12 PRE-INSTALLATION CONFERENCE

- A. Convene pre-installation conference one month prior to installation of landscape soils and irrigation work. The Contractor is to have done prior to the meeting:
 - 1. Provide initial soil testing of the soils proposed to be used to determine soil amendment procedures for soils.
 - 2. Provide information on the methods and procedures for amending, placement and recording the placement of the soil.
 - 3. Verify and demonstrate to the Construction Manager that soils will be uniformly mixed and amended to provide a consistent growing medium in planting beds throughout the entire duration of the project.
- B. Require attendance of parties directly affecting landscaping work.
- C. Review Contract Documents, procedures, and coordination required with related work.

1.13 DELIVERY, STORAGE, AND HANDLING

- A. Comply with the requirements specified in Section 016100.
- B. Deliver products in manufacturer's standard packaging.
- C. Store products to protect them from damage and contamination and comply with manufacturer's storage instructions.

D. Bulk Materials:

1. Do not dump or store bulk materials near structures, utilities, walkways and pavements, or on existing turf areas or plants.
2. Provide erosion-control measures to prevent erosion or displacement of bulk materials, discharge of soil-bearing water runoff, and airborne dust reaching adjacent properties, water conveyance systems, or walkways.
3. Do not move or handle materials when they are wet or frozen.
4. Accompany each delivery of bulk fertilizers and soil amendments with appropriate certificates.

PART 2 - PRODUCTS

2.01 IMPORTED TOPSOIL

- A. General: ASTM D 5268, free of stones 1 inch (25 mm) or larger in any dimension, and other extraneous materials harmful to plant growth. Texture: fertile, agricultural soil, capable of sustaining plant growth.
- B. Topsoil shall be used in the buildup of the soil profiles listed below as defined in the Contract Drawings and will comply with all other subsections of 2.01 herein.
 1. Soil Profile A – Lawn: 12 inches topsoil minimum
 2. Soil Profile B – Native Perennial Plants: 24 inches topsoil minimum
 3. Soil Profile C – Trees: 48 inches topsoil minimum.
- C. Soils:
 1. All soils for use on project will be from a homogenous blend from a single source unless formally approved by Architect/Engineer.
 2. Planting shall be corrected per recommendations of the independent soil testing laboratory and approved by Architect/Engineer.
 3. Planting soil to contain sufficient quantities of available nitrogen, phosphorous, potassium, calcium, magnesium, and organic matter to support normal plant growth. In the event of nutrient inadequacies, provisions shall be made to add required amendments prior to placement.
 4. Obtain soil from well-drained, arable land, where no noxious weeds such as Morning Glory, Sorrel, or Bermuda Grass are growing.
 5. Soil shall be "Sandy Loam" or "Loam" is classified per USDA Standards.

D. Testing of Soils to provide combination fertility, agricultural suitability, particle- size, and Water Holding Capacity performed by a soil testing laboratory approved by the Landscape Architect. Soil for initial selection to have the following characteristics:

1. Fertility: The range of essential elements concentration in soil shall be as follows:

Ammonium Bicarbonate/DTPA Extract	
Parts per million (mg/kilogram)	
Dry weight basis	
Phosphorus	2-40
Potassium	40-220
Iron	2-35
Manganese	0.3-6
Zinc	0.6-8
Copper	0.1-5
Boron	0.2-1
Magnesium	50-150
Sodium	0-100
Sulfur	25-500
Molybdenum	0.1-2

- a. Acidity: The soil pH range measured in the saturation extract (Method 21a, USDA Handbook number 60) shall be 6.5-7.5
- b. Salinity: The salinity range measured in the saturation extract (Method 3a, USDA Handbook Number 60) shall be 0.5 – 2.5 dS/m.

- c. Chloride: The maximum concentration of soluble chloride in the saturation extract (Method 3a, USDA Handbook Number 60) shall be 150 mg/1 ppm.
- d. Boron: The maximum concentration of soluble boron in the saturation extract (Method 3a, USDA Handbook Number 60) shall be 1 mg/1 ppm.
- e. Sodium Absorption Ratio (SAR): The maximum SAR shall be 3 (measured per method 20b, USDA Handbook Number 60).
- f. Aluminum: Available aluminum measured with the Ammonium Bicarbonate/DTPA Extraction shall be less than 3 parts per million.
- g. Calcium Carbonate Content: Free calcium carbonate (limestone) shall not be present for acid-loving plants.
- h. Heavy Metals- The maximum permissible element concentration in the soil shall not exceed the following:

Ammonium Bicarbonate/DTPA Extract	
in parts per million (mg/kilogram)	
Dry Weight Basis	
Arsenic	1
Cadmium	1
Chromium	10
Cobalt	2
Lead	30
Mercury	1
Nickel	5
Selenium	3
Silver	0.5
Vanadium	3

- i. If the pH is between 6 and 7, the maximum permissible elemental concentration shall be reduced 50 percent. If the soil is less than 6.0, the

maximum permissible elemental concentration shall be reduced 75 percent. No more than three metals shall be present at 50 percent or more of the above.

- j. Soil Organic Matter Content: Sufficient soil organic matter shall be present to impart good physical soil properties but not be excessive to cause toxicity or cause an excessive reduction in the volume of soil due to the decomposition of organic matter. The desirable range is 6 percent to 10 percent. The carbon/nitrogen ratio should be about 10.
- k. Soil Structure in a range described below:

Particle Size	Minimum	Maximum
Clay (<.002 mm)	5%	20%
Silt (.002-.05mm)	10%	30%
Coarse Sand (0.5-2.0mm)	0%	15%
Gravel (2-13mm)	0%	15%
Rock (Max aggregates size 1/2 -1 inch) 5% by volume with none > 1 inch		
Decomposed organic matter	0%	10%

- 1. Should the samples not meet all of the standards given above, the soil laboratory to submit in the report what additives should be installed to correct problems.
- E. Texture/Structure/Chemical Composition capable of supporting vigorous plant growth. Imported topsoil shall be of a composition to provide a satisfactory transition with native soil as determined by the Soils Testing Laboratory.
 - F. The Construction Manager reserves the right to require additional samples of topsoil at the site. If subsequent testing proves material to be at variance with the approved sample, remove rejected soil from the site and replace immediately, at no additional cost to the DEP.
 - G. Unsuitable soil: Soil that is designated as unsuitable for use as topsoil or plant pit backfill may be used as lawn and shrub area fill placed below the topsoil zone as required or removed offsite as directed by Construction Manager.
 - 1. Unacceptable Properties: Clean soil of the following:

- a. Unacceptable Materials: Concrete slurry, concrete layers or chunks, cement, plaster, building debris, oils, gasoline, diesel fuel, paint thinner, turpentine, tar, roofing compound, acid, and other extraneous materials that are harmful to plant growth.

2.02 STRUCTURAL SOIL

- A. Contractor to provide structural soils that have been tested and properly amended per the recommendation of testing laboratory and requirements of Section 329123.
- B. Texture/Structure/Chemical Composition capable of supporting vigorous plant growth. Imported topsoil shall be of a composition to provide a satisfactory transition with native soil as determined by the Soils Testing Laboratory.

2.03 ORGANIC COMPOST

- A. Natural organic material suitable for horticultural uses and shall comply with the recommendations of soil testing laboratory. Final determination of materials used will be based on recommendations of the testing laboratory analysis and report.
 - 1. Compost shall be a well decomposed, stable and weed free. It shall be derived from one or more locally sourced organic materials such as food waste or urban plant debris, agricultural crop residue or herbivore animal manures with a preference for urban plant debris and food waste. It shall not contain mixed solid waste. The product shall contain no substances toxic to plants, will possess no objectionable odors and shall not resemble the feedstock (the original material from which it was derived). Compost shall be tested through the US Composting Councils USCC Seal of Testing Assurance Program (STA). A lab analysis shall be performed by a STA certified laboratory using the test methods used in the Seal of Testing Assurance program found in the Test Methods for Examination of Compost and Composting Manual (TMECC). Verifying current participation in the STA program can be confirmed by logging onto the USCC website at www.compostingcouncil.com. The compost lab analysis shall be submitted as part of the “Compost Technical Data Sheet” before delivery of compost.
 - a. The compost laboratory report must confirm the following compost parameters:

Parameters	Units of measure	General Range
Nitrogen (Total N)	% dry weight	>0.9
Ammonium (N or NH4-N)	ppm or mg/kg dry weight	<450
Nitrate (NO3-N)	ppm or mg/kg dry weight	>10
Phosphorus (P)	% dry weight	<0.6
Calcium (Ca)	% dry weight	<3.5

Parameters	Units of measure	General Range
Boron (Total B)	ppm or mg/kg dry weight	<80
Sodium (Na)	% dry weight	<0.5
Total Nitrogen Phosphorus and Potassium (NPK)	Sum % dry weight	>2.0
Carbon Nitrogen Ratio	Carbon: Nitrogen	≤25:1
Organic Matter Content	% by dry weight basis	>35
pH	pH units	6.5-8.5
Moisture Content	% wet weight basis	>35
Particle Size or Sieve Size	% under ½” or 25mm by dry weight	>95%
Stability Indicator: Carbon Dioxide (CO2) Evolution Rate	Mg CO2-C/g OM per day	<8
Maturity Indicator: Cucumber Bioassay		
Seed Emergence	%, relative to control	>80%
Seed Vigor	%, relative to control	>80%
Select Pathogens		
Fecal Coliform Bacteria	MPN/gram dry weight	<1000
Salmonella	MPN/4gram dry weight	<3
Metals		
Arsenic	mg/kg (ppm)	<16
Cadmium	mg/kg (ppm)	<8
Chromium	mg/kg (ppm)	< 100
Copper	mg/kg (ppm)	<400
Lead	mg/kg (ppm)	<100
Mercury	mg/kg (ppm)	<4
Nickel	mg/kg (ppm)	<80
Selenium	mg/kg (ppm)	<5
Zinc	mg/kg (ppm)	<500
Physical Contaminants		
Glass	% dry weight	<1
Plastic	% dry weight	<1
Metal	% dry weight	<1
Bulk Density	lbs./CY dry weight lbs./CF dry weight	>19 and <41 >500 and <1100

(Table modified from the US Composting Council Landscape Architectural Specifications 6/1/05 and Alameda County Waste Management Authority Compost Quality Standards and Testing Protocol April 6, 2006)

- b. In addition, it is recommended that the compost laboratory report conforms to the following compost parameters.

Parameters	Units of measure	General Range
Boron (Soluble B)	ppm or mg/kg dry weight	<2.5
Soluble Sodium	% of ECE	<40
Soluble Chloride	% of ECE	< 50
Organics:		
Clyopyralid		Pass plant test
Organochlorine Pesticides		Non-Detect
Organophosphate Pesticides		Non-Detect
Chlorinated Herbicides		Non-Detect
Chlorinated Hydrocarbons		Non-Detect

(Table modified from the US Composting Council Landscape Architectural Specifications 6/1/05 and Alameda County Waste Management Authority Compost Quality Standards and Testing Protocol April 6, 2006)

2.04 FERTILIZERS AND CONDITIONERS:

- A. Manufactured fertilizers and conditioners suitable for horticultural uses and shall comply with the recommendations of soil testing laboratory. Final determination of materials used will be based on recommendations of the testing laboratory analysis and report.
- B. Shall comply with the applicable requirements of the State Agricultural Code. Fertilizing materials shall be packaged, first grade, commercial quality products identified as to the source, type of material, weight, and manufacturer's guaranteed analysis. Fertilizing material shall not contain toxic ingredients or fillers in quantities harmful to human, animal, plant or sea life.
- C. Fertilizer:
 - 1. Shall be determined from soils analysis results.
 - 2. Synthetic fertilizers or fertilizers prohibited by the OMRI in its “Generic Materials List” are not allowed in the project.
 - 3. Among fertilizers meeting the requirements of the soil test results, the fertilizers selected shall have lower toxicity, persistence, and bioavailability. Contractor shall provide documentation demonstrating how lower toxicity, persistence, and bioavailability were incorporated into the choice of the selected fertilizers.

PART 3 - EXECUTION

3.01 MATERIALS

- A. Coordination with the Work of other disciplines, adjacent materials and utilities.
- B. Soil preparation and planting is to be coordinated with adjacent work including but not limited to the following as shown on Planting Plans:
 - 1. Existing utilities
 - 2. Civil utilities
 - 3. Site mechanical and electrical utilities
 - 4. Telecommunications
 - 5. Site lighting
 - 6. Fire protection
 - 7. Irrigation
 - 8. Coordination:
- C. Verify that no unacceptable material has been deposited in planting soil.
- D. Proceed with placement only after unsatisfactory conditions have been corrected.

3.02 SURFACE CONDITIONS

- A. Prior to construction, the Contractor shall furnish a construction schedule which demonstrates that soil preparation and planting will not occur during the rainy season. The Contractor shall not proceed with soil prep and planting while the soil is wet.
- B. Inspections by the Contractor:
 - 1. Before proceeding with the work: Carefully inspect all areas and verify all dimensions and quantities.
 - 2. In the event of a discrepancy, immediately notify the Construction Manager. Do not proceed with this installation in areas of discrepancies until all such discrepancies have been fully resolved.
 - 3. Landscape Soil Preparation and subsequent planting operations shall be performed only during periods when beneficial results can be obtained. When excessive moisture or other unsatisfactory conditions prevail, the work shall be stopped until conditions are satisfactory.
 - 4. Coordinate rough grading of the site to ensure all planting areas graded to +0.10 ft. of finish grades shown on the Contract Drawings. Allow for depth of soil amendments and mulch in determining the difference between finished subgrade in

groundcover and shrub beds. Verify that subgrades are not compacted. Do not proceed until detrimental conditions are corrected. The Contractor shall take precautions during the excavation of all planting areas to not undermine or damage all adjacent pavements, footings and their associated subgrades.

5. Complete the rough grading as necessary to round the top and toe of all slopes, providing naturalized contouring to integrate newly graded areas with the natural topography unless otherwise noted.
6. Install all warning fabrics in accordance requirements of environmental protection of the site. Refer to Section 329400.
7. Finish grading under this section shall be completed in accordance with the section shown on the landscape grading plan and details.
8. Do not place topsoil prior to acceptance of all subgrade work by Construction Manager and warning fabrics are installed.

3.03 PLANTING AREA PREPARATION

- A. Weed control: Eradicate all non-sterile weeds. Ensure weeds are actively growing prior to spraying. Protect non-target species. Do not spray in temperatures over 32 degrees centigrade, during windy conditions nor if rain is forecasted within six hours. Comply with all safety, notification and application requirements appropriate to the material applied in strict accordance with manufacturer's instructions. Allow weeds to deteriorate approximately one week prior to any necessary re-treatment. After re-treated weeds have died, slash weeds and leave as mulch to be turned into the soil. Continue isolated or spot control of any further invasion or germination throughout the course of the Work. Synthetic Pre – Emergent is prohibited from use.
- B. Prior to any other work of planting area preparation, remove all rubble, waste, debris, wasted construction materials, and all other material that will interfere with proper planting area preparation. Areas to be planted shall be free of soil-borne diseases and capable of sustaining healthy plant life. Remove from the project site and dispose of in a legal manner any soils and material not meeting these requirements. In areas where conditions at the start of work differ materially from those prevailing at the time of pre-bid site observation by the Contractor, or where there are hidden deposits of deleterious materials, secure an on-site evaluation with the Architect/Engineer for the purpose of determining the value of any necessary extra work.
- C. Verify that subgrades for installation of stockpiled and/or import topsoil have been established under rough grading; subsoil grade depth plus specified depth of topsoil should equal finish grade. Do not spread topsoil prior to acceptance of all subgrade work by Construction Manager.
- D. Thoroughly scarify and cross-rip all planting areas to twelve (12) inches minimum depth prior to placement of appropriate topsoil.

3.04 FIELD QUALITY CONTROL

- A. Soil testing shall be provided throughout the planting operations of the project by the approved testing laboratory for planting and site soils.
- B. Provide a minimum of (3) tests with recommendations for each site soil as required. Amend soil per soil test recommendations.
 - 1. All imported soils contractor is to provide testing per 100 cubic yards of import. The Contractor is to provide a log of import with the applicable testing report. All 100 cubic yard import batches shall be reviewed and approved before installation.
- C. If the topsoil has been overly compacted or contaminated from construction, excavate to 3 feet deep and replace with topsoil approved by the Architect/Engineer.

3.05 TOPSOIL PLACEMENT

- A. Prior to placing topsoil, filter fabric shall be installed per Section 329400.
- B. Transport imported topsoil directly from source to final position. If stockpiling is required, Contractor to notify the Construction Manager for review of location and quantity prior to delivery.
- C. Water all areas thoroughly to wet the entire depth of topsoil and at least six inches into the native soil. After allowing the soil to dry to appropriate moisture content to be worked (the soil should be crumbly after being compressed in the hand), adjust grades, adding or removing appropriate topsoil as necessary, to the indicated finished grades prior to incorporating amendments. Keep grades high enough to compensate for initial compression of high-bulk amendments used. Do not leave soil surface so high, however, that soil sloughs onto paved surfaces or that surface runoff is misdirected. Investigate and correct any areas of poor infiltration, percolation, or drainage. Range: maintain within 2 percent above or below optimum moisture content at all times during the work.
- D. Topsoil Depth: As indicated on the Contract Drawings.
- E. Place first lift in a 6-in layer. Incorporate into “Clean Fill” to form a homogeneously blended layer 6-in in depth. (or) scarify the subgrade material prior to installing planting soil.
 - 1. Scarify the subsoil of the subgrade to a depth of a minimum depth of 6 inches or to depth as indicated in drawings with the tiller or other suitable device.
 - 2. Place 6 inches of new imported soil and till together with scarified from subgrade.
- F. Install the Planting Soil in 12-to-18-inch lifts to the required depths. Apply compacting forces to each lift as required to attain the required compaction. Scarify the top of each lift prior to adding more Planting Soil by dragging the teeth of a loader bucket or backhoe across the soil surface to roughen the surface.

- G. Phase work such that equipment to deliver or grade soil does not have to operate over previously installed Planting Soil. Work in rows of lifts the width of the extension of the bucket on the loader. Install all lifts in one row before proceeding to the next. Work out from the furthest part of each bed from the soil delivery point to the edge of each bed area.
- H. Furnish and install topsoil as required to meet grades as indicated on the Contract Drawings. Do not use sheepsfoot roller or other equipment that will produce excessive compaction. Maintain suitable compaction rates as described under paragraph 1.10 Soil Compaction.

3.06 COMPACTION REQUIREMENTS FOR INSTALLED PLANTING SOIL

- A. Compact installed Planting Soil to the compaction rates indicated and using the methods identified and suitable for good plant health described under paragraph 1.10 Soil Compaction.
- B. Installed Planting Soil Mix and re-spread existing soil shall have a soil density through the required depth of the installed layers of soil, such that the penetrometer reads approximately 75 to 250 psi at soil moisture approximately the mid-point between wilt point and field capacity. This will be approximately between 75 and 82 percent of maximum dry density standard proctor.
- C. Planting Soil compaction shall be tested at each lift using a penetrometer calibrated to the mockup soil and its moisture level. The same penetrometer and moisture meter used for the testing of the mockup shall be used to test installed soil throughout the work.
- D. Maintain moisture conditions within the Planting Soil during installation or modification to allow for satisfactory compaction. Suspend operations if the Planting Soil becomes wet. Apply water if the soil is overly dry.
- E. Provide adequate equipment to achieve consistent and uniform compaction of the Planting Soils. Use the smallest equipment that can reasonably perform the task of spreading and compaction. Use the same equipment and methods of compaction used to construct the Planting Soil mockup.
- F. Do not pass motorized equipment over previously installed and compacted soil except as authorized below.
 - 1. Light weight equipment such as trenching machines or motorized wheel barrows is permitted to pass over finished soil work.
 - 2. If work after the installation and compaction of soil compacts the soil to levels greater than the above requirements, follow the requirements of the paragraph "Over Compaction Reduction" below.

3.07 OVER COMPACTION REDUCTION

- A. Any soil that becomes compacted to a density greater than the specified density and/or the density in the approved mockup shall be dug up and reinstalled. This requirement includes compaction caused by other sub-contractors after the Planting Soil is installed and approved.
- B. Surface roto tilling shall not be considered adequate to reduce over compaction at levels 6 inches or greater below finished grade.

3.08 AMENDMENT OF SOIL

- A. General: After finish grading operations are completed, in all planting areas, rototill as required in at least 2 perpendicular directions, and with soil at the proper moisture content so that all clods greater than 1-inch diameter will be broken up resulting in a homogenous blend of amended soil.
- B. Install amendment materials in accordance to the recommendations provided under soils tests and continuous monitoring of new soils as they are being installed. Adjust amendment procedures if required based on new testing and new recommendations become evident.

3.09 FINISH GRADING

- A. Surface Drainage: The Contractor is responsible for proper surface drainage of planted areas. Report in writing to the Construction Manager any discrepancies in the Contract Documents, obstructions on the site, or any other conditions which the Contractor feels prevent establishing proper drainage and obtain the Construction Manager's approval prior to proceeding with the work affected.
- B. Final Contouring:
 - 1. Handle and place the topsoil and backfill mix to required depths as shown on the Contract Drawings. Remove all rocks and clods over one inch in diameter. Provide for surface drainage and cut all necessary drain swales.
 - 2. Work soil and backfill sufficiently so that after rolling and after a full settlement has occurred, the site will be graded to within +/- 0.10 of a foot from the lines, grades and elevations were shown and as may be directed by the Construction Manager. Finished surface shall be smooth and uniform and shall be free of depressions that retain standing water or any surface irregularities that would impede proper drainage. Unless otherwise noted, all finish grades shall be one (1) inch below finish grade of adjacent walks, pavements and curbs and top of wall elevations in turf areas and 2 inches below in all other planting areas.

3. Water all areas to settle the soil. After drying, correct low spots and irregularities, and re-establish finished grade to that specified. Finished grade must be observed and approved by the Construction Manager prior to plant installation.
4. Erosion Repair: Repair all erosion damage that occurs until Final Acceptance. Take all measures necessary to prevent erosion occurring during work under this Section. Provide and amend replacement soil and planter backfill mix in accordance with this Section.

3.10 DRAINAGE, DETRIMENTAL SOILS AND OBSTRUCTIONS

- A. Notify the Construction Manager in writing of any soil or drainage conditions the Contractor considers detrimental to plant growth. State condition and submit a proposal to improve drainage. If rock, underground construction work, tree roots or other obstructions are encountered in the excavation of the plant pits, alternate locations may be selected by the Construction Manager.
- B. Drainage Test: Sample tree pits shall be filled with 2 feet of water prior to planting and shall drain overnight. If pit fails to drain overnight, submit in writing a proposal for the correction to the Construction Manager before proceeding with the work. The number to be tested shall be one (1) pit per every five (5) pits.

3.11 PLANTING PIT AMENDMENT PROCEDURES

- A. Refer to the amendment procedures as listed under Section 329300.

3.12 CLOSEOUT ACTIVITIES

- A. Provide in accordance with Section 017700.

END OF SECTION 329113

SECTION 329123 – STRUCTURAL SOIL

PART 1 - GENERAL

1.01 DESCRIPTION

- A. This Section includes: The manufacturing, supplying, and installation of structural engineered planting soil made of a narrowly graded rock with blended soil. The blended material is designed to support pavements and provide adequate soil and void space to encourage tree root growth.
1. Acceptable products included under this Section:
 - a. CU SOIL as prepared under licensed soil blender from AMEREQ Inc., 19 Squadron Blvd. New City, NY 10956; Tel: 800.832.8788;
<http://amereq.com/pages/1/index.htm>
 - b. GAP Graded Soil. A blended structural engineered planting soil produced by the process described in this Section.
 - c. Advanced Soil Technologies
 - d. BRAEN Supply
 - e. Or approved equal
 2. The primary difference between CU SOIL and GAP Graded Soil is the type of polymer used and the gradation of aggregate used.
 3. Both products are to fulfill requirements of structural engineered planting soil as described under this Section. The use of CU SOIL does not exclude the following requirements and listed under this Section:
 - a. Agricultural Stability.
 - b. Soil Texture of Soil Once Blended.
 - c. Percentage of Void Space and Soil Infill.
 - d. Percolation.
 - e. Structural Bearing Capacity.

1.02 PAYMENT

- A. No separate payment shall be made for performing any Work required under this Section. All costs for Work required by this Section shall be included in the applicable unit price(s), or allowance(s) as set forth in Section 012901.

1.03 REFERENCES

- A. The following reference are used:
 - 1. ASTM: American Society of Testing Materials
 - 2. USDA: United States Department of Agriculture.
 - 3. AASHTO: American Association of State Highway and Transportation Officials.
 - 4. Standard Specifications: Regional or Municipal Standard Specifications Documentation for the location of proposed usage.
 - 5. AOAC: Association of Official Agricultural Chemists.
 - 6. ASA: American Society of America
 - 7. SSSA: Soil Science Society of America

1.04 RELATED SECTIONS

- A. General Conditions Article 4.7 – Shop Drawings and Other Submittals.
- B. Section 012901 – Measurement and Payment
- C. Section 014300 - Quality Requirements.
- D. Section 016100 - Control of Materials.
- E. Section 017700 - Contract Closeout.
- F. Section 329300 – Soil Preparation and Planting
- G. Requirements from the following sections also apply to this Section:
 - 1. Section 312300 – Excavation and Fill
 - 2. Section 329113 – Soil Preparation and Finish Grading
 - 3. Section 329300 - Planting

1.05 REQUIREMENTS OF REGULATORY AGENCIES

- A. Perform work in accordance with all applicable laws, codes, and regulations required by authorities having jurisdiction over such work and provide for all inspections and permits required by Federal, State and local authorities in furnishing, transporting and installing materials.

1.06 SYSTEM DESCRIPTION

- A. Design Requirement: Test, adapt and refine Structural Soil mix design to suit locally available materials, project site conditions, mock-up performance and the Landscape Architect’s review. Mix design includes but is not limited to the proportion of components, amendment types and its application rates.
- B. Performance Requirement: Be responsible for all means, techniques and methods to achieve the soil characteristics specified.

1.07 SUBMITTALS

- A. Submit the following in accordance with General Conditions Article 4.7.
- B. Product Data:
 - 1. Submit product information for the following materials:
 - a. Raw Materials.
 - 1) Crushed / Base Stone
 - 2) Proposed Infill Soil
 - 3) Organic Amendment
 - b. Polymer Soil Conditioner
 - c. Additional Amendment(s) based on recommendations from soil analysis for both initial product review and blended materials.
 - 2. For manufactured mixes submit data sheets including certificates, certified tests, and manufacturer’s literature with samples for all proposed materials.
 - a. Include with all product data for all “Raw Materials”:
 - 1) Source location of all material(s) proposed. Include contact information.
 - 2) History of the source material(s). Provide information that describes the consistency of the material. Documentation is to provide adequate information describing variations and availability on quantities equal to quantities for project.
 - 3) Provide the most current documentation for “Raw Materials” with older information for comparison purposes. Current documentation to be no older than 2 months from the date of submittal.

- C. Qualifications: Proposed testing laboratory for approval prior to sampling.
- D. Samples for Verification: Provide testing for two stages before final acceptance for each of the following:
1. 5 lb (2.2 kg) of each type and each source of Crushed Stone required, in labeled plastic bags showing sample name, location and date. Submit at least 28 days prior to ordering or processing. Provide testing reports for proposed crushed stone.
 - a. Particle size per (USDA Designation Size)
 - 3" / 76 mm
 - 2-1/2" – 3" / 63-76 mm
 - 2" – 2-1/2" / 50-63 mm
 - 1-1/2" – 2" / 37-50 mm
 - 1" / 25-37 mm
 - 3/4" - 1" / 19-25 mm
 - Fine gravel – 1/8" – 3/4" / 2-19 mm
 - Sand - 0.05 to 2 mm
 - Silt - 0.002 to 0.05 mm
 - Clay - minus 0.002 mm
 - b. Provide complete supplier analysis for the following:
 - 1) Stone material type.
 - 2) Analysis for salts, heavy metals, and pH level.
 - 3) Loose and rodded unit weights.
 - 4) Percent Void Space for both loose and rodded material.
 - 5) Bulk specific gravity and absorbance.
 - 6) Gravel dimension and surface texture description.
 - 7) Aggregate soundness and L.A. abrasion.
 2. 5 lb (2.2 kg) of each type and each source of Infill Soil required, in labeled plastic bags showing sample name, location and date. Submit at least 28 days prior to ordering or processing. Provide testing reports for proposed infill soil.
 - a. Bulk density and particle size analysis of sample, include the following gradient of mineral content (USDA Designations provide sizes in mm)
 - 1) Gravel: Over 2 mm
 - 2) Sand: 0.05 to 2 mm
 - 3) Silt: 0.002-0.05 mm
 - 4) Clay: Minus 0.002 mm
 - b. Submit a sieve analysis performed and compared with USDA Soil Classification System. Sieve analysis shall be by a combined hydrometer and wet sieving using sodium hexametaphosphate as a dispersant in accord with

Particle-size Analysis, Chapter 15, Methods of Soil Analysis, Part, SSSA-ASA, Inc., 1986.

- c. Submit a chemical analysis performed in accordance with current ASA standards, including the following:
 - 1) pH
 - 2) Percent organic matter as determined by total organic carbon, and total nitrogen. Test samples shall be oven-dried to a constant weight at a temperature of 105 degrees C.
 - 3) Analysis for nutrient levels and toxic elements by parts per million including nitrate nitrogen, and extractable phosphorus, potassium, magnesium, manganese, iron, zinc, copper, boron, sulfate, calcium, molybdenum, sodium, aluminum, arsenic, cadmium, chromium, cobalt, lead, lithium, mercury, nickel, selenium, silver, strontium, tin, and vanadium. Nutrient tests shall include testing laboratory recommendations for supplemental additions to soils as calculated by the amount of material to be added per volume of soils for type of plants to be grown in the soil.
 - 4) Soluble salt by electrical conductivity of a saturated paste extract measured in Millimho per cm, soluble calcium, magnesium, potassium, sodium, sulfate, chloride, nitrate, and boron.
3. 5 lb (2.2 kg) of each type and each source of Provide testing reports for proposed crushed stone.
4. Compost required, in labeled plastic bags showing sample name, location and date. Submit at least 28 days prior to ordering or processing. Provide laboratory– Laboratory analysis as per specifications by the supplier of compost or by suppliers testing laboratory. Manufacturer’s certification that the compost meets the requirements for US Compost Council STA/TMECC criteria for “Compost as a Landscape Backfill Mix Component” and other requirements of the Specification.
5. 5 lb (2.2 kg) of each type and each source of proposed Composite Structural Engineered Planting Soil after the proposed soil, rock and other amendments have been reviewed and accepted, in labeled plastic bags showing sample name, location and date. Submit at least 28 days prior to ordering or processing. Provide a complete analysis with recommendations testing to include soil analysis with soil classifications for infill soil, complete aggregate gradation, and an analysis of determining of percent void space without soil and percent void space with soil.

E. Source Quality Control - Soil Reports:

1. For each proposed Structural Soil type - Submit Soils Report describing all proposed components, composition, amendments, test results, analysis, trial results, interpretations and source location at least 28 days prior to ordering or processing.

- F. Additional Material Testing: Based on Construction Manager discretion structural engineered soil to be tested for additional requirements. Tests could include one or more of the tests as listed below:
 - 1. Compaction in accordance with ASTM D698/AASHTO T99 without removing oversized aggregate.
 - 2. Maximum Dry Bulk Density Test Reports of the amended soil (ASTM D-1557)
 - 3. The percent moisture content of the amended soil.

 - G. Quality Control Material Testing Requirements:
 - 1. Provide testing of blended soil for every 500 cubic yards of imported material. Submittal of material for each batch to be reviewed and approved before shipment.
 - 2. During the amending and mixing process:
 - a. Complete Standard Analysis of five composite samples of the amended soil prior to the mixing with rock.

 - H. Field Quality Control - Soil Reports:
 - 1. For each proposed Structural Soil type - Submit test results showing compliance of soils after placing but at least 14 days prior to planting.
 - 2. Water Infiltration Test – using a double ring method. The water infiltration rate is to be a minimum of 3/4"¾ inch per hour.

 - I. Quantity Requirements:
 - 1. Submit for verification the quantities needed for project submit the following:
 - a. A plan identifying locations and depths of material including volumes of by zone.
 - b. Provide total estimated quantity of imported material by cubic yards.
 - 2. Identify in plans locations of material that will be coordinated for quality control testing. Include in plans:
 - a. Placement schedule and quantities of placement.
 - b. Locate on plans locations of post-placement testing.

 - J. Approval by the Construction Manager of submitted product data, samples, test reports, and certificates shall not constitute final acceptance.
- 1.08 QUALITY ASSURANCE
- A. Comply with the requirements specified in Section 014300.

- B. Testing Laboratory Qualifications: An approved independent laboratory, recognized by the State Department of Agriculture, with the experience and capability to conduct the testing indicated and that specializes in types of tests to be performed. Provide the laboratory with representative samples and a copy of the Contract Document Planting Plans and Specifications. Test, analyze and interpret in accordance with current AOAC standards.
- C. Mixer & Installer Qualifications: Submit qualifications outlining projects of similar quality, schedule requirements and construction detailing over the last 5 years. Include the names of all similar projects, year completed, location, description of the scope of work including the types and quantities of planting mix / pavement material installed and the name, address and telephone number of the DEP or the Construction Manager.
- D. Soil Reports: As a minimum include the following in each Soil Report:
 - 1. Sampling: Methods used to achieve a true representation of soil variability.
 - 2. Soil Analysis: Test for the specified characteristics. Continue to sample and retest until each proposed soil type conforms to the specified characteristics. Pay for all such testing.
 - 3. Interpretation: Report on suitability of each Structural Soil type for growing plants indicated on the Plant List and to support pavements. Propose recommended quantities of amendments to be added to produce conforming soils. Substantiate with data and/or research any proposed alternatives.
- E. DEP reserves to right to have Structural Soil tested independently.
- F. Mock-ups:
 - 1. Construct a mock-up of Structural Soils representative of all work necessary to complete the job, including installing backfill mix at specified depths and applying water to include settlement that may occur with rain or irrigation. The mock-up is to establish standards for quality, grading, compaction and finishing to the satisfaction of the Landscape Architect and Construction Manager. Adjust mix design and execution methods as necessary. If approved, mockup may be incorporated into the works.
 - a. Minimum mock-up volume – 5 cubic yards.
- G. Field Observation: Give not less than 14 working days' notice so that field observations may be made of the following:
 - 1. Mock-up.
 - 2. Prepared Structural Soil prior to placing cover material.

1.09 DELIVERY, STORAGE, AND HANDLING

- A. Comply with the requirements specified in Section 016100.
- B. Prevent spillage when hauling on or adjacent to any public street or highway. In the event that spillage occurs, remove all spillage and sweep, wash, or otherwise clean such streets or highways as required by local City, County and/or the State Authorities.
- C. Take precautions to prevent a dust nuisance to adjacent public or private properties and to prevent erosion and transportation of soil to downstream or adjacent properties due to work under this Contract. At project site exit, clean dirt from tires. Do not track dirt onto highways.
- D. Prior to delivery, propose suitable stockpile locations. Stockpile to a 6-foot-high maximum and protect from traffic, wind and water erosion. Provide temporary seeding and/or erosion control measures as approved by Construction Manager.
- E. Use quality control sampling and testing to ensure that delivered materials match the approved samples/mock-ups and the specified criteria.
- F. Do not deliver or place soils in frozen, wet, or muddy conditions. Deliver at or near optimum compaction moisture content as determined by AASHTO T 99 (ASTM D 698). Do not deliver or place materials in an excessively moist condition (beyond 2 percent above optimum compaction moisture content as determined by AASHTO T 99 (ASTM D 698)).
- G. Protect soils and mixes from absorbing excess water and from erosion at all times. Do not store materials unprotected from large rainfall events. Do not allow excess water to enter site prior to compaction. If water is introduced into the material after grading, allow material to drain or aerate to optimum compaction moisture content.
- H. Before Structural Soil is redistributed from stockpiles homogenize to make a uniform mix, free of subgrade lenses and other irregularities.

1.10 PRECONSTRUCTION MEETING

- A. Prior to any mixing or installation of Structural Engineered Planting Soil Mix, the Construction Manager will hold a pre-installation meeting with the Contractor to discuss schedules, methods, and techniques for the mixing and delivery of the material.
- B. Required representatives are to attend the meeting:
 - 1. Contractor
 - 2. Construction Manager
 - 3. Landscape Architect
 - 4. Blender of Soil

5. Installers of Soil

C. The meeting is to review the following at a minimum:

1. Schedule
2. Extent of Work
3. Materials and Equipment to be used
4. Submittal procedure and Approval of an Acceptable Structural Engineering Planting Soil Mix for the project.
5. Testing procedures for both the quality control of material as it is blended and installed.
6. Mockup requirements and schedule of Mockups.
7. Material Storage and Protection.
8. Weather Conditions Placement
9. Cleanup and Disposal of Waste Material.

1.11 SEQUENCING

- A. All areas to receive structurally engineered planting soils shall be inspected by the Construction Manager before starting work, and all defects such as incorrect grading, compaction, and inadequate drainage and other unacceptable conditions shall be corrected prior to beginning work.
1. Do not commence work until unsatisfactory conditions have been corrected, and areas are ready to accept structural engineered planting soil.
- B. Coordination with Utilities: Ensure the works are staged and sequenced to;
1. Minimize tracking of heavy equipment and compacting planting areas.
 2. Prevent mixing, contamination or reversing Structural Soil profile from utility excavations and back filling. Repair any disturbance to the Structural Soil layers after placing to comply with the specified requirements.

1.12 COORDINATION

- A. Coordinating stockpiles: Be responsible for any necessary temporary storage and staging of Structural Soil works including relocating stockpiles to accommodate the scheduling of other work.

1.13 MAINTENANCE

- A. Maintenance Instructions: Submit within fourteen days of Substantial Completion, recommended procedures to be established by DEP for removal and replacement of Structural Soils.

PART 2 - PRODUCTS

2.01 PERFORMANCE DESIGN STRUCTURAL ENGINEERED PLANTING SOIL

- A. General: Custom blended of approved gravel/rock, infill soil, organic amendments, chemical amendments, and polymer conditioner. Final composite material shall be suitable for planting and accommodate structural loads.
- B. Infill soils shall be conditioned with amendments and polymer conditioner according to testing laboratory recommendations and per requirements of AMEREQ if CU Soil.
- C. Initial mix design for testing shall be determined by adjusting the ratio between gravel/rock and soil such that the volume percent of soil in mix is not less than 45% nor more than 55 percent of available void space in the gravel as determined from stone rodded unit and bulk density of soils or by separation of the components.
- D. Raw materials of rock/gravel and amended infill soil are measured and blended until homogenous. Once blended, have the soil mixture tested for soil fertility as outlined under this Section. The tested blended soil is to achieve the void space under this Section and have a void infill percentage as described under this Section.
- E. Based on the assessment for soil testing laboratory make necessary changes to the blended soil to make the soil in conformance for fertility and/or acceptable ratio of void and infill soil ratio.
- F. If required by Construction Manager provide additional testing identified under Paragraph 1.07 F of this Section submit testing reports showing conformation.

2.02 MIX PROPORTIONS

- A. Mix design is based on volume ratio to establish a clear understanding of rock available void space and infill soil. The mix design is simplified but can be adjusted to the proportion of the volume of material needed for the project.

Raw Materials ^a	Unit of Volume Cubic Feet
Specified Crushed Stone ^b	100
Specified Clay Loam ^c	20 to 28 ^d
Polymer Additive	
For GAP Soil - Pam	0.0370 lb. per Cubic Foot of Import Infill Soil ^e
For CU SOIL - Gelscape® Hydrogel Tackifier	0.035 Units Dry Weight of Stone and Soil
Chemistry of Blended Material ^f	
pH	6.5 to 7.5 adjustable to 7.0
Organic Content	3% to 7%

^a All raw materials to be provided dry basis.

^b Stone that meets the specified material in accordance with paragraph 2.2A02A for 1 ½ inch rock providing available void space percentage of 44 percent to 50 percent based on a rodded unit for the total volume of stone. One cubic foot of stone weighs approximately 98 lbs dry weight.

^c Clay Loam that meets the specified soil in accordance with paragraph 2.2 B. Soils for consideration can be corrected by appropriate methods as established by soil testing laboratory and approved. One cubic foot of specified soil weighs in the range of 109 to 115 lbs. dry weight.

^d Volume of soil to fill available rock void space by 45 percent to 55 percent.

^e Per Cubic Yard of Soil provides 1 pound of Pam.

^f Blended soil to meet the basic requirements listed in the chart above but also meets the requirements listed under paragraph 2.2B02B. If blended soil doesn't match these requirements the blended soil can adjust to have soil be within the acceptable range for horticultural suitability.

- B. The Contractor can use a weight ratio method providing the results and testing information includes information for available rock void space and infill ratio for infill soil. Contractor to submit method for blending with test results.
- C. The moisture content of the final blended soil is not to be excessively wet. The ratio of water content to the overall soil blend is 10+/- pounds for every 120+/- pound of blended soil. Water ratio includes weight from water provided in other ingredients.

2.03 MATERIALS

- A. Crushed Stone (Minimum Standards for Acceptance):
 1. General: Crushed stone shall be a uniform material of angular rock ¾ inches to 1 ½ inches allowing for up to 10 percent being greater than 1 ½ inches, and up to 10 percent less than ¾ inches.
 2. Acceptable aggregate dimensions will not exceed 2.5:1.0 for any two dimensions.
 3. Minimum 90 percent with two or more fractured faces.
 4. Results of the Aggregate Soundness Loss test shall not exceed 18 percent.
 5. Losses from the LA Abrasion test not to exceed 40 percent.
 6. Chemical Analysis: Standard chemical properties involve heavy metals below phytotoxic levels, soluble salts <300 ppm, and 6 > pH < 7.5.
 7. Additional Information Required for Crushed Stone Submittals
 - a. Accurate data is essential as the primary unit of measurement for the rock will be weight tags from the quarry of origin.
 - b. Specific Gravity: Available from the quarry.
 - c. Bulk Density: Bulk density supplied by the quarry pounds per cubic yard. Bulk density of the rock will require five random tests to confirm, using a minimum four cubic foot container.
 8. Percent Void Space within the Rock Matrix: The void is determined through the following tests.

- a. Water-filled capacity.
- b. Specific gravity and the weight of a known volume of rock. Void space can also be calculated directly from quarry data on bulk density and specific gravity.
- c. The design range of void space is 44 to 50 percent. Adjustments to the stone matrix can be made to increase the available void space.

B. Infill Soil:

1. Infill soils shall be a clay loam based on "USDA classification system" as determined by mechanical analysis and shall be of uniform composition, without admixture of subsoil. It shall be free of stones greater than one-half inch, lumps, plants and its roots, debris, and other extraneous matter larger than one inch in diameter or an excess of smaller pieces of same type materials as determined by Owner, Construction Manager and Landscape Architect . It shall not contain toxic substances harmful to plant growth. It shall be obtained from naturally well-drained areas that have never been stripped of topsoil before and have a history of satisfactory vegetative growth.
2. Fertility: The range of essential elements concentration in soil shall be as follows or adjusted accordingly to meet these guidelines as determined by soil analyses:

<u>Element</u>	<u>Ammonium Bicarbonate/DPTA Extract Parts per million (mg/kilogram). Dry weight basis</u>
Phosphorus	2 – 40
Potassium	40 – 220
Iron	2 – 35
Manganese	0.3 – 6
Zinc	0.6 – 8
Copper	0.1 – 5
Boron	0.2 – 1
Magnesium	50 – 150
Sodium	0 – 100
Sulfur	25 - 500
Molybdenum	0.1 - 30

3. Acidity: The soil pH range measured in the saturation extract (Method 21a, USDA Handbook number 60) shall be 6.0 – 7.5.
4. Salinity: The salinity range measured in the saturation extract, the maximum salinity shall be 4.0 dS/m.
5. Chloride: The maximum concentration of soluble chloride in the saturation extract (Method 3a, USDA Handbook Number 60) shall be 150-mg/1 ppm.
6. Boron: The maximum concentration of soluble boron in the saturation extract (Method 3a, USDA Handbook Number 60) shall be 1 mg/1 ppm.

7. Sodium Absorption Ratio (SAR): The maximum SAR shall be 6 (measured per Method 20b, USDA Handbook Number 60).
8. Calcium Carbonate Content: Free calcium carbonate shall not be present.
9. Heavy Metals: The maximum permissible elemental concentration in the soil shall not exceed the following:

<u>Element</u>	<u>Ammonium Bicarbonate/DPTA Extract</u> <u>Parts per million (mg/kilogram)</u> <u>Dry weight basis</u>
Arsenic	2
Cadmium	2
Chromium	10
Cobalt	2
Lead	30
Mercury	1
Nickel	5
Selenium	3
Silver	0.5
Vanadium	3

If the pH is between 6 and 7, the maximum permissible elemental concentration shall be reduced by 50 percent. If the soil pH is less than 6.0, the maximum permissible elemental concentration shall be reduced by 75 percent. No more than three metals shall be present at 50 percent or more of the above values.

10. Phytotoxic constituent, herbicide, hydrocarbons: Germination and growth of plants shall not be restricted more than 10 percent compared to standard controls. Standard controls shall be both monocots and dicots. Total petroleum hydrocarbons shall not exceed 100mg/kg dry soil measure per EPA Method No. 8002.
 11. Soil Organic Matter Content: Sufficient soil organic matter shall be present to impart good physical soil properties but not be excessive to cause toxicity or cause an excessive reduction in the volume of soil due to the decomposition of organic matter. Soil shall contain not less than 3 percent or more than 7 percent organic matter as determined by organic carbon and total nitrogen on oven-dried samples.
- C. Organic Amendment: Organic material is to be well-composted humus with the following properties:
1. Humus material shall have a mineral content of no less than 8 percent and no more than 50 percent.
 2. The pH of the material shall be between 6 and 7.5.
 3. The salt content shall be less than 10 millimho/cm @ 25 degrees c. (ece less than 10) on a saturated paste extract. If the concentration of calcium sulfate in the saturation extract is greater than 25 milliequivalents per liter, the maximum level

of salinity can be increased 3 millimho/cm @ 25 degrees c. Units (13 millimho/cm @ 25 degrees c).

4. Boron content of the saturated extract shall be less than 1.0 parts per million.
5. Silicon content (acid-insoluble ash) shall be less than 20 percent.
6. Calcium carbonate shall not be present if the amendment is applied to alkaline soils.
7. Types of acceptable products are composts, manures, mushroom composts, straw, alfalfa, sludge, peat mosses, etc. low in salts, low in heavy metals, free from weed seeds, free of pathogens and other deleterious materials.
8. Composted wood products are conditionally acceptable (stable humus must be present). Wood-based products are not acceptable which are based on redwood or cedar.
9. Sludge-based materials are not acceptable if the soil already has a high level (toxic level) of zinc, copper, or other heavy metals based on soil analysis.
10. Carbon: Nitrogen ratio is less than 25:1.
11. The compost shall be aerobic without malodorous presences of decomposition products.
12. The maximum particle size shall be 1.27 cm, 80 percent more shall pass a No. 4 screen.
13. Maximum total permissible pollutant concentrations in the organic amendment in parts per million or a dry weight basis:

Arsenic	20	Molybdenum	60
Cadmium	15	Nickel	100
Chromium	100	Selenium	30
Cobalt	50	Silver	10
Copper	150	Vanadium	50
Lead	100	Zinc	200
Mercury	10		

D. Polymer Soil Conditioner:

1. A granular or liquid, non-toxic water-soluble polymers to improve soil hydration and is specifically intended for landscape/agricultural use.
2. Acceptable Products:
 - a. For CU Soil: Hydrogel consisting of potassium propenoate-propenamide copolymer (Gelscape® Hydroget Tackifier) as manufactured by Amereq, Inc.
 - b. For GAP graded soils: P.A.M. (polyacrylamide) available from Complete Green Company, 365 Coral Circle, El Segundo, CA 90245, Ph (310) 640-6815.

- c. Advanced Soil Technologies
 - d. BRAEN Supply
 - e. Or approved equal
- 3. Application: Polymer Soil Conditioner is applied to the base soil with other soil amendments at the time of screening. The polymer is then applied in a water solution and allowed to cure.
 - 4. Application Rate: As per the manufacturer’s instructions or as per approved Soil Laboratory recommendations based upon soil textural qualities.
- E. Additional amendments, as required pending soil testing results:
- 1. Fertilizer: Commercial fertilizer complying with state laws. Use percentages of the weight of ingredients and application rates shall be determined by soil testing results.
 - 2. Gypsum: Agricultural mineral containing a minimum of 92 percent calcium sulfate dihydrate.
 - a. Minimum gradation:

100% Passing	#10 Mesh Sieve
98% Passing	#20 Mesh Sieve
60% Passing	#60 Mesh Sieve
40% Passing	#100 Mesh Sieve

2.04 FILTER FABRIC

- A. Woven, UV stabilized, polypropylene geotextile with the following properties.
 - 1. Grab Tensile Strength (ASTM D 4632) 140 lb. min.
 - 2. Mullen Burst Strength (ASTM D 3786) 325 psi. min.
 - 3. Puncture Strength (ASTM D 4833) 60 lb. min.
 - 4. Apparent opening size (ASTM D 4751) 0.600 mm min.
- B. All Filter Fabric shall be delivered in 12” (min.) wide rolls.

PART 3 - EXECUTION

3.01 EXAMINATION

- A. Inspect all areas to receive Structural Soil before starting work and all defects such as incorrect grading, compaction and inadequate drainage etc. and report to the Landscape Architect prior to beginning this work.

- B. Existing Utilities: Locate and mark existing utilities, underground structures, and aboveground obstructions before excavation. Do not interrupt utilities serving facilities occupied by DEP or others unless permitted in writing by Construction Manager.

3.02 PREPARATION

- A. Do not proceed with the installation of the Structural Soil material until all walls, curb footings and utility work in the area have been installed. For site elements dependent on Structural Soil for foundation support, postpone installation until immediately after the installation of Structural Soil.
- B. Install subsurface drain lines as shown on the Contract Drawings prior to installation of Structural Soil.
- C. Excavate and compact the proposed sub-grade to depths, slopes and widths as shown on the Contract Drawings. Maintain all required angles of repose of the adjacent materials as shown on the Contract Drawings. Do not over excavate compacted sub-grades of adjacent pavement or structures.
 - 1. Excavation of Tree Trench:
 - a. Excavate tree-planting trench as indicated on Contract Documents.
 - b. Dispose of excavated spoils.
- D. Confirm that the sub-grade is at the proper elevation and compacted as required. Slope sub-grade elevations parallel to the finished grade and or toward the subsurface drain lines if shown on the Contract Drawings.
- E. Clear the excavation of all construction debris, trash, rubble and any foreign material. In the event that fuels, oils, concrete washout silts or other material harmful to plants have been spilled into the sub-grade material, excavate the soil sufficiently to remove the harmful material. Fill any over excavation with approved fill and compact to the required sub-grade compaction.
- F. Protect adjacent walls, walks and utilities from damage or staining by the soil. Use 1/2 inch" plywood and or plastic sheeting as directed to cover existing concrete, metal and masonry work and other items as directed during the progress of the work.
 - 1. Clean up all trash and any soil or dirt spilled on any paved surface at the end of each working day.
 - 2. Any damage to the paving or architectural work caused by the soils installation shall be repaired by the Contractor at the Contractor's expense.
- G. Provide adequate methods to assure that trucks and other equipment do not track soil from the site onto adjacent property and the public right of way.

3.03 INSTALLATION OF FILTER FABRIC

- A. Install Filter Fabric as shown on the Contract Drawings and whenever the underlying subgrade fill material is sufficiently coarse to permit significant migration of particles from Structural Soil into the subgrade material below. This condition is defined by the following formula:
 - 1. Particle migration will occur when the D-15 of the subgrade material particles is equal to or larger than 5 times the D-85 of the Clay Loam particles in the Structural Soil above. The D-15 of the subgrade material is defined as the diameter through which the smallest 15 percent of the subgrade particles (by weight) would pass. The D-85 of the Structural Soil particles is defined as the diameter through which the smallest 85 percent of the subgrade particles (by weight) would pass.
- B. Maintain a minimum of 12 inches overlap at all Filter Fabric joints.
- C. Install Structural Soil without damage to Filter Fabric at bottom and sides of trenches.

3.04 SOIL AMENDING AND CONDITIONING FOR GAP GRADED STRUCTURAL SOIL

- A. Incorporate dry amendments during the initial screening – all amendments including compost and dry polymer soil conditioner are incorporated during screening. Amendments are applied at the rate specified by the approved soil testing laboratory. Soil amendments are measured on a pounds per cubic yard of soil basis. The maximum particle size after the first screening is 1/2 inch (1.27 cm).
 - 1. Measurement – The volume of a front loader bucket is used as the primary unit for bulk soil measurement. Precise measurements of the volume of the bucket, as well as the average bulk density of a level bucket, are required. Fertilizer and amendments are measured in volumes appropriate for each unit (tractor bucket full). The maximum bulk density is to be recorded (ASTM D-1557). The average percent of moisture content is to be determined and recorded as well.
- B. Preparation for Liquid Polymer Soil Conditioner Treatment:
 - 1. After the screening, spread the soil in a large flat area to a depth of 12 inches.
 - a. The site must have good drainage.
 - b. The process of spreading the material shall be done in a manner that the front-end loader does not drive over or compact any of the soil.
 - c. Form a small berm at the top edge of the soil to retain the liquid polymer.
- C. Mix the polymer with water per instructions:

1. The water tank shall have a minimum of 500-gallon/1,900 liters capacity and a discharge pump.
- D. Apply the solution to the surface of the soil.
- E. Allow the solution to infiltrate until inspection reveals that the soil is evenly saturated with the liquid polymer solution.
- F. Curing of amended soil:
 1. Allow the soil to cure and dry for a minimum of two days before disturbing.
- G. Stockpiling Soil: The soil shall be stockpiled until needed in a location as directed by the Construction Manager and Landscape Architect. Optimum moisture content for working the soil is 20 percent. Optimum moisture should be maintained by covering the stockpiled soil with a tarp to prevent drying, or the opposite, in the event of rain.
- H. Screening: Screen the amended and conditioned soil to ½“ inch maximum particle size just prior to mixing with the structural rock. Mixing should occur just prior to installation.

3.05 PROCEDURE FOR MIXING ROCK AND SOIL

- A. General: Creating a good root medium depends upon accurate measurement and sufficient mixing. Rock soil shall be mixed until they are homogenous because any area of the mix having too high a proportion of soil will be subject to later settling.
- B. The stone, infill soil, and polymer soil conditioner/hydrogel shall be mixed at a location where it can be stored up to 45 days. During this time, it must be covered by tarps to prevent drying. If rock and amended soil is mixed off-site and stored prior to use, piles of material should be on larger than 1,000 cubic feet each. Piles are to be covered by a plastic tarp to prevent changes in moisture.
- C. All mixing shall be performed off-site using appropriate stone and soil, measuring, mixing, and shredding equipment of sufficient capacity and capability to assure proper quality control. No mixing of soils at the project site shall be permitted.
- D. Perform mixing in a clean area free of materials that may contaminate mix.
- E. Variable Blending Procedure: No matter how much mixing takes place prior to depositing in the trench, further blending must take place inside the trench. The structural soil is mixed with either a backhoe or excavator bucket until well homogenized.
- F. The Contractor shall have available at the mixing site sufficient equipment and instrumentation, including qualified technicians, to determine weights and water content of the mix components immediately prior to the mixing procedure. The contractor shall monitor these critical elements throughout the mixing process to provide adequate quality control. The Contractor shall maintain a quality control log of material weight, water content, and mix proportions for every 500 cubic feet of material mixed.

- G. The Contractor shall mix sufficient material in advance of the time needed at the site job to allow adequate time for testing as required by the progress of the work. Engineered Structural Soil Mix shall be stored in piles of no more than 500 cubic feet and each pile shall be numbered for identification and testing purposes.
- H. The Contractor shall submit three-particle size distribution analyses from samples taken randomly through every 500 cubic feet of structural soil mix prepared. If the particle size distribution varies significantly from the approved sample, as determined by the Construction Manager and Landscape Architect, make adjustments to the mixing ratios or procedures and re-mix the lot. Re-test any lot of soil that fails to meet correct analysis after the adjustment has been made.
- I. Correcting mistakes in blending: If the mix is found to be incorrect after depositing in the plating trench, additional rock or soil can be added and blended. The blending of the structural soil mixing is complete ONLY when the Construction Manager and Landscape Architect has provided a written acceptance to the Contractor.

3.06 CU-SOIL MIXING

- A. All CuCU-Structural Soil mixing shall be performed at a licensed producer's yard using appropriate soil measuring, mixing, and shredding equipment and has the capability to assure proper quality control and consistent mix ratios. No mixing of CU-Structural soil at the project site shall be permitted.
- B. Maintain adequate moisture content during the mixing process. Soils and mix components shall easily shred and break down without clumping. Soil clods shall easily break down into a fine crumbly texture. Soils shall not be overly wet or dry. The licensed producer shall measure and monitor the amount of soil moisture at the mixing site periodically during the mixing process.

3.07 INSTALLATION AND COMPACTION

- A. Soil Installation and Compaction:
 - 1. Compact structural soil to a minimum 95 percent of peak dry density or per requirements identified by the geotechnical engineer.
 - 2. Compact the mix in successive layers, each lift having a maximum thickness of 8 to 12 inches (20.32 cm to 30.48 cm). If compaction is not acceptable to the Construction Manager, lift thickness may be reduced.
 - 3. Compact the mix by using a small roller. Corners and irregular areas, which the roller cannot reach, are to be compacted with a hand tamper. Vibrating compactors or jackhammer type compactors shall not be used. Delay compaction 24 hours if moisture content exceeds maximum allowable and protect Structural Soil during delays in compaction with plastic or plywood as directed by the Construction Manager and Landscape Architect.

- B. Scarify Soil Surface: After each lift has been compacted, scarify the top 2 inches (5.08 cm) of soil before installing the next lift.
- C. Procedure at Tree Pits:
 - 1. Hold the tree planting pits open to facilitate the installation of the tree root balls. Only planting soil mix, not structural soil shall be used for planting backfill, in the immediate vicinity of the root ball as shown on the Contract Drawings.
 - 2. Refer to Section 329300 for planting soil mix requirements.
- D. Bring Structural Soils to finished grades as shown on the Contract Drawings. Immediately protect the Structural Soil material from contamination by toxic materials, trash, debris, water containing cement, clay, silt or materials that will alter the particle size distribution of the mix with plastic or plywood as directed by the Construction Manager and Landscape Architect.

3.08 FINE GRADING

- A. After the initial placement and rough grading of the Structural Soil but prior to the start of fine grading, the Contractor shall request review of the rough grading by the Landscape Architect. The Contractor shall set sufficient grade stakes for checking the finished grades.
- B. Adjust the finish grades to meet field conditions as directed.
 - 1. Provide smooth transitions between slopes of different gradients and direction.
 - 2. Fill all dips and remove any bumps in the overall plane of the slope.
 - 3. All fine grading shall be inspected and approved by the Landscape Architect prior to the installation of other items to be placed on the Structural Soil.

3.09 TOLERANCES

- A. Comply with tolerances as follows:
 - 1. Elevation: 1/2 inch.
 - 2. Surface smoothness: Gap below 10-foot- long straightedge not to exceed 1/2 inch in any direction.
 - 3. Slope: unless otherwise noted on the Contract Drawings not less than 1 percent fall.

3.10 FIELD QUALITY CONTROL

- A. Testing Agency: Engage a qualified independent geotechnical engineering testing agency to perform field quality-control testing.

- B. Test compaction of soils in place according to ASTM D 1556, ASTM D 2167, ASTM D 2922, and ASTM D 2937, as applicable. Perform tests at the following locations and frequencies:
 - 1. At each compacted fill layer, at least one test for every 2000 sq. ft. or less of paved area, but in no case fewer than three tests.
- C. When testing agency reports that Structural Soils have not achieved degree of compaction specified, scarify and moisten or aerate, or remove and replace soil to depth required; recompact and retest until specified compaction is obtained.
- D. Review by Construction Manager: The Landscape Architect shall review the grading and retains the right to direct adjustments the grading within (5) days of review. Adjustments that only involve cut to fill without exporting or importing additional material shall be executed without cost to the DEP.
- E. The Landscape Architect may periodically check the material being delivered and installed at the site for color and texture consistency with the approved sample provided by the Contractor as part of the submittal for Structural Soil. In the event that the installed material varies significantly from the approved sample, the Landscape Architect may request that the Contractor test the installed Structural Soil. Any soil that varies significantly from the approved testing results, as determined by the Landscape Architect, shall be removed and new Structural Soil installed that meets these Specifications Sections.

3.11 CLEAN-UP

- A. Upon completion of the Structural Soil installation operations, clean areas within the contract limits. Remove all excess fills, soils and mix stockpiles and legally dispose of all waste materials, trash and debris. Remove all trash, tools and equipment and provide a clean, clear site. Sweep, do not wash, all paving and other exposed surfaces of dirt and mud until the paving has been installed over the Structural Soil. Do not wash until finished materials covering Structural Soil material are in place. Scars, ruts or other marks in the area caused by this work shall be repaired at the Contractor's expense, and the ground left in a neat and orderly condition.

3.12 DISPOSAL

- A. Disposal: Remove surplus satisfactory soil and waste material, including unsatisfactory soil, trash, and debris, and legally dispose of it off the City of Hoboken's property.

3.13 CONTRACT CLOSEOUT

- A. Provide in accordance with Section 017700.

END OF SECTION 329123

SECTION 329200 - TURF AND GRASSES

PART 1 - GENERAL

1.01 DESCRIPTION

- A. Provide turf and grasses as indicated and in compliance with Contract Documents.
 - 1. Scope includes:
 - a. Seeding.
 - b. Fertilizing.
 - c. Mulching.
 - d. Herbicide.

1.02 PAYMENT

- A. No separate payment shall be made for performing any Work required under this Section. All costs for Work required by this Section shall be included in the applicable lump sum, as set forth in Section 012901.

1.03 REFERENCES

- A. State Department of Transportation (DOT):
 - 1. NJDOT Specifications: New Jersey Department of Transportation Standard Specifications for Road and Bridge Construction, current edition.
- B. Association of Official Seed Analysts (AOSA)
 - 1. AOSA Rules for Testing Seeds, current edition.

1.04 RELATED SECTIONS

- A. General Conditions Article 4.7 – Shop Drawings and Other Submissions.
- B. Section 012901 – Measurement and Payment
- C. Section 014300 – Quality Requirements
- D. Section 016100 - Control of Materials
- E. Section 017423 – Cleaning Up

- F. Section 017700 – Contract Closeout
- G. Section 329113 - Soil Preparation
- H. Section 329700 - Landscape Maintenance

1.05 DEFINITIONS

- A. Finish Grade: Elevation of finished surface of planting soil.
- B. Pesticide: A substance or mixture intended for preventing, destroying, repelling, or mitigating a pest. Pesticides include insecticides, miticides, herbicides, fungicides, rodenticides, and molluscicides. They also include substances or mixtures intended for use as a plant regulator, defoliant, or desiccant.
- C. Pests: Living organisms that occur where they are not desired or that cause damage to plants, animals, or people. Pests include insects, mites, grubs, mollusks (snails and slugs), rodents (gophers, moles, and mice), unwanted plants (weeds), fungi, bacteria, and viruses.
- D. Planting Soil: Existing, on-site soil; imported soil; or manufactured soil that has been modified with soil amendments and perhaps fertilizers to produce a soil mixture best for plant growth. See Section 329113 and drawing designations for planting soils.
- E. Subgrade: The surface or elevation of subsoil remaining after excavation is complete, or the top surface of a fill or backfill before planting soil is placed.
- F. Subsoil: All soil beneath the topsoil layer of the soil profile and typified by the lack of organic matter and soil organisms.
- G. Surface Soil: Soil that is present at the top layer of the existing soil profile at the Project site. In undisturbed areas, the surface soil is typically topsoil, but in disturbed areas such as urban environments, the surface soil can be subsoil.

1.06 SUBMITTALS

- A. Submit the following in accordance with General Conditions Article 4.7.
- B. Qualification Data: For landscape Installer, see Section 014300 and Paragraph 1.07 of this Section.
- C. Certification of Grass Seed: From seed vendor for each grass-seed monostand or mixture, stating the botanical and common name, percentage by weight of each species and variety, and percentage of purity, germination, and weed seed. Include the year of production and date of packaging.
- D. Product Certificates: For fertilizers, from manufacturer.

- E. Pesticides and Herbicides: Product label and manufacturer's application instructions specific to Project.
- F. Maintenance Data: Recommended procedures to be established by Owner for maintenance of turf during a calendar year. Submit before expiration of required maintenance periods.

1.07 QUALITY ASSURANCE

- A. Comply with Section 014300.
- B. Installer Qualifications: A qualified landscape installer whose work has resulted in successful turf establishment.
 - 1. Professional Membership: Installer shall be a member in good standing of either the Professional Landcare Network or the American Nursery and Landscape Association.
 - 2. Experience: Five years' experience in turf installation. Installer's Field Supervision: Require Installer to maintain an experienced full-time supervisor on Project site when work is in progress.
 - 3. Personnel Certifications: Installer's field supervisor shall have certification in all of the following categories from the Professional Landcare Network:
 - a. Certified Landscape Technician - Exterior, with installation, maintenance and irrigation specialty area(s), designated CLT-Exterior.
 - b. Certified Turfgrass Professional, designated CTP.
 - c. Certified Turfgrass Professional of Cool Season Lawns, designated CTP-CSL.
 - 4. Pesticide Applicator: State licensed, commercial.
 - 5. Soil-Testing Laboratory Qualifications: An independent laboratory or university laboratory, recognized by the State Department of Agriculture, with the experience and capability to conduct the testing indicated and that specializes in types of tests to be performed.

1.08 DELIVERY, STORAGE, AND HANDLING

- A. Comply with Section 016100.
- B. Seed and Other Packaged Materials: Deliver packaged materials in original, unopened containers showing weight, certified analysis, name and address of manufacturer, and indication of compliance with state and Federal laws, as applicable.

C. Bulk Materials:

1. Do not dump or store bulk materials near structures, utilities, walkways and pavements, or on existing turf areas or plants.
2. Provide erosion-control measures to prevent erosion or displacement of bulk materials; discharge of soil-bearing water runoff; and airborne dust reaching adjacent properties, water conveyance systems, or walkways.
3. Accompany each delivery of bulk materials with appropriate certificates.

1.09 FIELD CONDITIONS

- A. Seeding Restrictions: Seed during one of the following periods. Coordinate seeding periods with initial maintenance periods to provide required maintenance from date of planting completion.
1. Spring Planting: March 1 to May 15.
 2. Fall Planting: August 15 to October 1.
- B. Seeding which cannot be completed during these periods may be performed at other times when, in the opinion of the Construction Manager, weather and soil conditions are suitable.
- C. Weather Limitations: Proceed with planting only when existing and forecasted weather conditions permit planting to be performed when beneficial and optimum results may be obtained. Apply products during favorable weather conditions according to manufacturer's written instructions.

1.10 MAINTENANCE SERVICE

- A. Initial Turf Maintenance Service: Provide full maintenance by skilled employees of landscape Installer. Maintain as required in Part 3 of this Section. Begin maintenance immediately after each area is planted and continue until acceptable turf is established but for not less than the following periods:
1. Sodded Turf: 30 days from the date of planting completion. Provide for a temporary overhead spray with domestic water for the 90 Day Establishment Period.
- B. Landscape Maintenance Period: Subject to requirements, conform with Section 329700.

PART 2 - PRODUCTS

2.01 SEED

- A. Grass Seed: Fresh, clean, dry, new-crop seed complying with AOSA's "Rules for Testing Seeds" for purity and germination tolerances.
- B. Seed Species:
 - 1. Quality: With each shipment of seed mixture, provide a certified weigh ticket and an analysis of the composition, purity, germination, germination test date, and sell by date of the seed mixture, certified by the seed house. The Construction Manager may sample and test seed according to the New Jersey State Seed Law and with the Rules and Regulations for Testing Seeds adopted by the Association of Official Seed Analysts. Seed of grass species as listed below for seed bed area:
 - 2. Type A-3 Seed Mixture, (Basic Highway Mix) to be used as basic seed mix for normal seed bed conditions:
 - a. 60 percent Tall Fescue, 95 percent minimum purity, 80 percent minimum germination.
 - b. 10 percent Kentucky Bluegrass, 85 percent minimum purity, 75 percent minimum germination.
 - c. 20 percent Chewings Fescue, 95 percent minimum purity, 85 percent minimum germination.
 - d. 10 percent Perennial Ryegrass, 98 percent minimum purity, 85 percent minimum germination.
 - 3. Type D Seed Mixture, to be used in public park and residential areas and where refined turf is needed:
 - a. 50 percent Kentucky Bluegrass, 85 percent minimum purity, 75 percent minimum germination.
 - b. 35 percent Red Fescues (Creeping or Chewings), 95 percent minimum purity, 85 percent minimum germination.
 - c. 5 percent Redtop, 92 percent minimum purity, 85 percent minimum germination.
 - d. 10 percent Perennial Ryegrass, 95 percent minimum purity, 90 percent minimum germination.

4. Steep Slope/No-Mow Cover Mix, to be used in steep slope areas as designated in landscape contract drawings:
 - a. 35 percent Creeping Red Fescue (*Festuca rubra*)
 - b. 27.5 percent Hard Fescue ‘Beacon’ (*Festuca brevipila*, ‘Beacon’)
 - c. 27.5 percent Hard Fescue ‘Gladiator’ (*Festuca ovina* var. *duriuscula*, ‘Gladiator’)
 - d. 10 percent Annual Ryegrass (*Lolium multiflorum*)

2.02 FERTILIZERS

- A. Commercial Fertilizer: Fertilizer for establishing turf shall have a commercial designation of 5-10-5 or 10-20-10 or any 1-2-1-ratio fertilizer containing a minimum of 5 percent nitrogen, 10 percent available phosphoric acid (P₂O₅), and 5 percent soluble potash (K₂O).

2.03 MULCHES

- A. Straw Mulch: Provide air-dry, clean, mildew- and seed-free, salt hay or threshed straw of wheat, rye, oats, or barley.
- B. Fiber Mulch: Biodegradable, dyed-wood, cellulose-fiber mulch; nontoxic and free of plant-growth or germination inhibitors; with a maximum moisture content of 15 percent and a pH range of 4.5 to 6.5.
- C. Non-asphaltic Tackifier: Colloidal tackifier recommended by fiber-mulch manufacturer for slurry application; nontoxic and free of plant-growth or germination inhibitors.
- D. Synthetic Plastic Emulsion: High polymer synthetic plastic emulsions of mulch binder shall be miscible with all normally available water when diluted to any proportion. After adequate drying, the synthetic plastic binder shall no longer be soluble or dispersible in water but shall remain tacky until the grass seed has germinated. The plastic binder shall be physiologically harmless and shall not have any phototoxic or crop damaging properties. The manufacturer's recommendations for rate of application shall be followed.
- E. Vegetable-Based Gels: Vegetable-based gel materials, which can be classified as naturally occurring powder based hydrophilic additives formulated to provide gels, which, when applied under satisfactory curing conditions, shall form membrane networks of water insoluble polymers. The vegetable gel shall be physiologically harmless and shall not have phototoxic or crop-damaging properties. The manufacturer's recommendations for rates of application shall be followed.

2.04 PESTICIDES

- A. General: Pesticide, registered and approved by the EPA, acceptable to authorities having jurisdiction, and of type recommended by manufacturer for each specific problem and as required for Project conditions and application. Do not use restricted pesticides unless authorized in writing by authorities having jurisdiction.
- B. Pre-Emergent Herbicide (Selective and Nonselective): Effective for controlling the germination or growth of weeds within planted areas at the soil level directly below the mulch layer.
- C. Post-Emergent Herbicide (Selective and Nonselective): Effective for controlling weed growth that has already germinated.
- D. Apply herbicides according to N.J.A.C 7:301 et seq.

2.05 EROSION-CONTROL MATERIALS

- A. Erosion-Control Blankets: Biodegradable wood excelsior, straw, or coconut-fiber mat enclosed in a photodegradable plastic mesh. Include manufacturer's recommended steel wire staples, 6 inches long.
- B. Erosion-Control Fiber Mesh: Biodegradable burlap or spun-coir mesh, a minimum of 0.92 lb/sq. yd., with 50 to 65 percent open area. Include manufacturer's recommended steel wire staples, 6 inches long.
- C. Erosion-Control Mats: Cellular, nonbiodegradable slope-stabilization mats designed to isolate and contain small areas of soil over steeply sloped surface, of sufficient thickness, strength and void space to allow soil filling or retention and the development of vegetation within the matrix. Include manufacturer's recommended anchorage system for slope conditions.

PART 3 - EXECUTION

3.01 EXAMINATION

- A. Examine areas to be planted for compliance with requirements and other conditions affecting installation and performance of the Work.
 - 1. Verify that no foreign or deleterious material or liquid such as paint, paint washout, concrete slurry, concrete layers or chunks, cement, plaster, oils, gasoline, diesel fuel, paint thinner, turpentine, tar, roofing compound, or acid has been deposited in soil within a planting area.

2. Suspend planting operations during periods of excessive soil moisture until the moisture content reaches acceptable levels to attain the required results.

3. Uniformly moisten excessively dry soil that is not workable, or which is dusty.

B. Proceed with installation only after unsatisfactory conditions have been corrected.

C. If contamination by foreign or deleterious material or liquid is present in soil within a planting area, remove the soil and contamination as directed by Landscape Architect and replace with new planting soil.

3.02 PREPARATION

A. Protect structures; utilities; sidewalks; pavements; and other facilities, trees, shrubs, and plantings from damage caused by planting operations.

1. Protect adjacent and adjoining areas from hydroseeding and hydromulching overspray.

2. Protect grade stakes set by others until directed to remove them.

B. Install erosion-control measures to prevent erosion or displacement of soils and discharge of soil-bearing water runoff or airborne dust to adjacent properties and walkways.

3.03 TURF AREA PREPARATION

A. Placing Planting Soil: Provide minimum 12 inches of topsoil to meet indicated finish grade. After areas have been brought to indicated finish grade, incorporate fertilizer into soils minimum depth of 12 inches by disking, harrowing, tilling or other method approved by the Architect/Engineer. Remove debris and stones larger than 3/4 inch in any dimension remaining on the surface after finish grading. Correct irregularities in finish surfaces to eliminate depressions. Protect finished topsoil areas from damage by vehicular or pedestrian traffic.

B. Moisten prepared area before planting if soil is dry. Water thoroughly and allow surface to dry before planting. Do not create muddy soil.

C. Before planting, obtain Construction Manager's acceptance of finish grading; restore planting areas if eroded or otherwise disturbed after finish grading.

3.04 PREPARATION FOR EROSION-CONTROL MATERIALS

A. Prepare area as specified in Section 329113.

- B. For erosion-control mats, install planting soil in two lifts, with second lift equal to thickness of erosion-control mats. Install erosion-control mat and fasten as recommended by material manufacturer.
- C. Fill cells of erosion-control mat with planting soil and compact before planting.
- D. For erosion-control blanket or mesh, install from top of slope, working downward, and as recommended by material manufacturer for site conditions. Fasten as recommended by material manufacturer.
- E. Moisten prepared area before planting if surface is dry. Water thoroughly and allow surface to dry before planting. Do not create muddy soil.

3.05 SEEDING

- A. Sow seed with spreader or seeding machine. Do not broadcast or drop seed when wind velocity exceeds 5 mph.
 - 1. Evenly distribute seed by sowing equal quantities in two directions at right angles to each other.
 - 2. Do not use wet seed or seed that is moldy or otherwise damaged.
 - 3. Do not seed against existing trees. Limit extent of seed to outside edge of planting saucer.
- B. Sow seed at a total rate of:
 - 1. Type A-3 Seed Mixture, (Basic Highway Mix) to be used as basic seed mix for normal seed bed conditions, shall be sown at the rate of 100 pounds per acre.
 - 2. Type D Seed Mixture, to be used in public park and residential areas and where refined turf is needed, shall be sown at the rate of 150 pounds per acre.
- C. Rake seed lightly into top 1/8 inch of soil, roll lightly, and water with fine spray.
- D. Protect seeded areas with slopes exceeding 1:4 with erosion-control blankets and 1:6 with erosion-control fiber mesh installed and stapled according to manufacturer's written instructions.
- E. Protect seeded areas with erosion-control mats where indicated on the Contract Drawings; install and anchor according to manufacturer's written instructions.
- F. Protect seeded areas with slopes not exceeding 1:6 by spreading straw mulch. Spread uniformly at a minimum rate of 2 tons/acre to form a continuous blanket 1-1/2 inches in loose thickness over seeded areas. Spread by hand, blower, or other suitable equipment.

1. Anchor straw mulch by crimping into soil with suitable mechanical equipment.
2. Bond straw mulch by spraying with asphalt emulsion at a rate of 10 to 13 gal./1000 sq. ft. Take precautions to prevent damage or staining of structures or other plantings adjacent to mulched areas. Immediately clean damaged or stained areas.

3.06 HYDROSEEDING

- A. Hydroseeding: Mix specified seed, commercial fertilizer, and fiber mulch in water, using equipment specifically designed for hydroseed application. Continue mixing until uniformly blended into homogeneous slurry suitable for hydraulic application.
1. Sow seed at total rate of:
 - a. Steep Slope/No-Mow Cover Mix: 233 pounds per acre
 2. Mix slurry with non-asphaltic tackifier.
 3. Spray-apply slurry uniformly to all areas to be seeded in a one-step process. Apply slurry at a rate so that mulch component is deposited at not less than 1500-lb/acre dry weight, and seed component is deposited at not less than the specified seed-sowing rate.
 4. Spray-apply slurry uniformly to all areas to be seeded in a two-step process. Apply first slurry coat at a rate so that mulch component is deposited at not less than 500-lb/acre dry weight, and seed component is deposited at not less than the specified seed-sowing rate. Apply slurry cover coat of fiber mulch (hydromulching) at a rate of 1000 lb/acre.

3.07 TURF RENOVATION

- A. Renovate existing turf where indicated.
- B. Renovate turf damaged by Contractor's operations, such as storage of materials or equipment and movement of vehicles.
1. Reestablish turf where settlement or washouts occur or where minor regrading is required.
 2. Install new planting soil as required.
- C. Remove sod and vegetation from diseased or unsatisfactory turf areas; do not bury in soil.
- D. Remove topsoil containing foreign materials, such as oil drippings, fuel spills, stones, gravel, and other construction materials resulting from Contractor's operations, and replace with new planting soil.

- E. Mow, dethatch, core aerate, and rake existing turf.
- F. Remove weeds before seeding. Where weeds are extensive, apply selective herbicides as required. Do not use pre-emergence herbicides.
- G. Remove waste and foreign materials, including weeds, soil cores, grass, vegetation, and turf, and legally dispose of them off Owner's property.
- H. Till stripped, bare, and compacted areas thoroughly to a soil depth of 6 inches.
- I. Apply initial fertilizer required for establishing new turf and mix thoroughly into top 4 inches of existing soil. Install new planting soil to fill low spots and meet finish grades.
 - 1. Initial Fertilizer: Commercial fertilizer applied according to manufacturer's recommendations.
- J. Apply seed and protect with straw mulch as required for new turf.
- K. Water newly planted areas and keep moist until new turf is established.

3.08 TURF MAINTENANCE

- A. General: Maintain and establish turf by watering, fertilizing, weeding, mowing, trimming, replanting, and performing other operations as required to establish healthy, viable turf. Roll, regrade, and replant bare or eroded areas and remulch to produce a uniformly smooth turf. Provide materials and installation the same as those used in the original installation.
 - 1. Fill in as necessary soil subsidence that may occur because of settling or other processes. Replace materials and turf damaged or lost in areas of subsidence.
 - 2. In areas where mulch has been disturbed by wind or maintenance operations, add new mulch and anchor as required to prevent displacement.
 - 3. Apply treatments as required to keep turf and soil free of pests and pathogens or disease. Use integrated pest management practices whenever possible to minimize the use of pesticides and reduce hazards.
- B. Watering: Install and maintain temporary piping, hoses, and turf-watering equipment to convey water from sources and to keep turf uniformly moist to a depth of 4 inches.
 - 1. Schedule watering to prevent wilting, puddling, erosion, and displacement of seed or mulch. Lay out temporary watering system to avoid walking over muddy or newly planted areas.

2. Water turf with fine spray at a minimum rate of 1 inch per week unless rainfall precipitation is adequate.
- C. Mow turf as soon as top growth is tall enough to cut. Repeat mowing to maintain specified height without cutting more than one-third of grass height. Remove no more than one-third of grass-leaf growth in initial or subsequent mowings. Do not delay mowing until grass blades bend over and become matted. Do not mow when grass is wet. Schedule initial and subsequent mowings to maintain the following grass height:
 1. Mow Type A-3 and Type D seed mixture grasses to a height of 1-1/2 to 2-inches.
- D. Turf Postfertilization: Apply commercial fertilizer after initial mowing and when grass is dry.
 1. Use fertilizer that provides actual nitrogen of at least 30 lb/acre to turf area.

3.09 SATISFACTORY TURF

- A. Turf installations shall meet the following criteria as determined by Construction Manager:
 1. Satisfactory Seeded Turf: At end of the Landscape Maintenance Period, a healthy, uniform, close stand of grass has been established, free of weeds and surface irregularities, with coverage exceeding 90 percent over any 10 sq. ft. and bare spots not exceeding 5 by 5 inches.
- B. Use specified materials to reestablish turf that does not comply with requirements and continue maintenance until turf is satisfactory.

3.10 PESTICIDE APPLICATION

- A. Apply pesticides and other chemical products and biological control agents according to requirements of authorities having jurisdiction and manufacturer's written recommendations. Coordinate applications with Owner's operations and others in proximity to the Work. Notify Owner before each application is performed.
- B. Post-Emergent Herbicides (Selective and Nonselective): Apply only as necessary to treat already-germinated weeds and according to manufacturer's written recommendations.

3.11 CLEANUP AND PROTECTION

- A. Comply with Section 017423.
- B. Promptly remove soil and debris created by turf work from paved areas. Clean wheels of vehicles before leaving site to avoid tracking soil onto roads, walks, or other paved areas.

- C. Remove surplus soil and waste material, including excess subsoil, unsuitable soil, trash, and debris, and legally dispose of them off Owner's property.
- D. Erect temporary fencing or barricades and warning signs as required to protect newly planted areas from traffic. Maintain fencing and barricades throughout the 90 Day Establishment Period and remove after plantings are established.
- E. Remove nondegradable erosion-control measures after the 90 Day Establishment Period.

3.12 MAINTENANCE SERVICE

- A. Turf Maintenance Service: Provide full maintenance by skilled employees of landscape installer. Maintain as required in Paragraph 3.08 of the Section. Begin maintenance immediately after each area is planted and continue until acceptable turf is established, but for not less than the following periods:
 - 1. Seeded Turf: 60 days from date of Substantial Completion.
 - a. When the 90 Day Establishment Period has not elapsed before end of planting season, or if turf is not fully established, continue maintenance during next planting season.

3.13 CONTRACT CLOSEOUT

- A. Provide in accordance with Section 017700.

END OF SECTION 329200

NO TEXT ON THIS PAGE

SECTION 329300 – PLANTING

PART 1 - GENERAL

1.01 DESCRIPTION

- A. Provide transportation, labor, materials, and equipment to perform planting operations, 90 Day Establishment Period and Landscape Maintenance Period as indicated and in compliance with Contract Documents.
 - 1. Trees
 - 2. Shrubs
 - 3. Ornamental Grasses
 - 4. Groundcover Plant Installation
 - 5. Top Dressing (mulch)
- B. The 90-Day Establishment Period will begin following the pre-maintenance inspection as described in paragraph 3.09. After the 90-Day Establishment Period is completed and accepted by the NJDEP the Landscape Maintenance Period will begin as described in Section 329700.

1.02 PAYMENT

- A. No separate payment shall be made for performing any Work required under this Section. All costs for Work required by this Section shall be included in the applicable lump sum as set forth in Section 012901.

1.03 REFERENCES

- A. Nomenclature shall comply with the latest editions of:
 - 1. Standardized Plant Names of the American Joint Committee on Horticulture Nomenclature.
 - 2. Hortus Third, Bailey Hortorium, Cornell Owner (1976).
- B. Sizing and grading shall comply with:
 - 1. “US Standards for Nursery Stock”, 2004, American Association of Nurserymen.

- C. Existing tree value appraisal shall comply with Council of Tree and Landscape Appraisers:
 - 1. Manual for Plant Appraisers Handbook.
 - 2. Guide for Establishing Values of Trees and Other Plants.
- D. Pruning standards: ANSI Z1333.1 – 1972, Safety Requirements for Tree Pruning, Trimming, Repairing or Removal.
- E. Tree Care Standards: ANSI A300 Standards for Tree Care Operations

1.04 RELATED SECTIONS

- A. General Conditions Article 4.7 – Shop Drawings and Other Submittals.
- B. Section 012901 – Measurement and Payment.
- C. Section 014300 - Quality Requirements.
- D. Section 016100 - Control of Materials.
- E. Section 017423 – Cleaning Up.
- F. Section 017700 - Contract Closeout.
- G. Section 329113 – Soil Preparation
- H. Section 329400 – Planting Accessories
- I. Section 329700 – Landscape Maintenance

1.05 REQUIREMENTS OF REGULATORY AGENCIES

- A. Perform work in accordance with all applicable laws, codes, and regulations required by authorities having jurisdiction over such work and provide for all inspections and permits required by Federal, State and local authorities in furnishing, transporting and installing materials.
- B. Certificates of inspection required by law for transportation shall accompany invoice for each shipment of seed or sod. Inspection by Federal or State Governments at the place of growth does not preclude rejection of materials at the project site.

1.06 SUBMITTALS

- A. Submit the following in accordance with General Conditions Article 4.7.
- B. Product Data: For each type of product indicated.

C. Plant materials lists and plant procurement:

1. Verification of Availability: With 60 days of contract execution, the Contractor shall provide written verification of ability to procure plant material as identified in drawings. At this time substitutions can be submitted for consideration. Substitution procedure must follow General Conditions Articles 4.7.
 - a. Substitutions are identified as; variety variations; greater size of plant stock than specified, plants that are equal in characteristics such as size, form, flowering than the originally specified plant. The DEP is not obligated to accept plant substitutions except in cases where agricultural regulations preclude availability.
 - b. The Construction Manager reserves the right to require the Contractor to replace at the Contractor's cost any plants which the Contractor has installed without the Construction Manager's approval.
2. Planting procurement documentation is to provide a complete plant list with sizes, types, and quantities of all plants intended to be delivered to the site.
 - a. Provide a schedule to ensure the size of plant material as identified in the Contract Drawings is obtained for installation to be approved by the Landscape Architect.
 - b. Provide a schedule showing the timeline of procurement and installation for all plant types and species.
 - c. The plant list is also to include a clear listing all nursery sources by plant type.
 - 1) A single source for individual plant species is required. Sourcing a single plant species from multiple suppliers to meet the quantity required as identified in the Contract Drawings is not acceptable.
 - d. All plant material provided to the project is to meet all standards for nursery stock.
3. Upon final acceptance of plant procurement, the selection of all material for the project is finalized and no substitution will be furthered allowed. Substitutions will only be allowed under the following conditions:
 - a. Plant material is damaged due to poor weather conditions. The Contractor is to provide written confirmation from nursery clearly identifying the extent of the damage. The letter is to be provided before acceptance of substitution.
 - b. Agricultural regulations restricting the transportation of plant material.

- c. Schedule delays caused by the Contractor or the Contractor's lack of coordination of work is not a basis for acceptance of substitution.

D. Initial Submittal for Trees Review:

1. The Contractor shall include as part of the plant procurement submittal a package for trees proposed for the project for initial review. Submittal is to clearly identify the source, sizes of trees including photographs of each tree type (with a person for scale purposes). Upon review by the Architect/Engineer an initial acceptance of will be made. At that time of initial consideration, the Architect/Engineer's discretion will determine if the field tagging of trees will be made. Allowance for expenses to tag trees by Architect/Engineer is for nurseries within 150 miles from the site. Nursery locations further than 150 miles from the job site is absorbed by the Contractor or negotiated by the DEP and the Contractor.

- E. Notice of Bill: The Contractor shall secure all material and provide proof of such within 30 days of Notice of approval of plant procurement in order to guarantee plant availability at time of planting.

- F. Mulch Samples: Provide 1 samples of each of mulch materials in 0.25 cubic foot clear plastic bags 30 Calendar Days prior to installation.

1.07 QUALITY ASSURANCE

- A. Comply with the requirements specified in Section 014300.

- B. The Contractor shall be responsible for furnishing plants inspected by appropriate State, Federal and County laws and certified to be free from disease, insect infestations, or other deleterious conditions at the growing site. Plants shall be tagged with species and variety prior to delivery to the project site. Untagged plants will be rejected whether or not of the specified species or variety.

C. Plant Material Standards:

1. Inspection and/or certification at the growing site does not preclude the Construction Manager's right to reject plants at the project site.
2. Plants are subject to evaluation by the Construction Manager at any time before or during the progress of the work and throughout the duration of the Guarantee period.
3. Plant Certification: All plants must meet specifications of Federal, State, and County laws requiring inspection for plant disease and insect infestations. Inspection certifications required by law shall accompany each shipment, invoice and order for stock.

4. Codes and Standards: Nursery stock shall meet the standards of the current edition of the “American Standard for Nursery Stock”, and the "Regulations of the Director of Agriculture Pertaining to Nursery Stock". They shall be true to type and name in accordance with "Standardized Plant Names", Second Edition.
 5. The Contractor is responsible for furnishing only nursery grown stock. Pre-selected material tagged by Landscape Architect must be inspected by the Contractor and certified pest and disease free. It is the Contractor’s obligation to warranty all plant material per specification.
 6. Plants shall be subject to inspection and approval of the Architect/Engineer at place of growth or upon delivery for conformity to specifications. Such approval shall not impair the right of inspection and rejection during progress of the work. Wherever the terms "approve", "approval" or "approved" are used herein they mean approval of the Landscape Architect in writing.
 7. Remove all rejected plants from the site immediately upon their rejection.
- D. Qualifications of Workers: Assign a full-time employee to the job as Foreman for the duration of the Contract with a minimum of three (3) years experience in landscape installation. Foreman will present on-site at all times during the execution of this portion of the Work. This person shall be thoroughly familiar with the type of materials being installed and the proper materials and methods for their installation, and who shall direct all work performed under this Section.
1. The Contractor shall coordinate his/her work that the Contractors working in and adjacent to the areas included in the Project area, and cooperate with the Construction Manager in the performance of his/her work.
 2. All work shall be in strict accordance with sound nursery practice and shall include maintenance and watering of all materials installed in this Contract until final acceptance by the Construction Manager.
- 1.08 SUBSTITUTIONS
- A. Substitution procedure must comply with General Conditions Articles 4.7.
 - B. Substitutions of plant materials will not be permitted unless authorized in writing by Architect/Engineer . If proof is submitted that any plant specified is not obtainable, a proposal will be considered for use of the nearest equivalent size or variety with corresponding adjustment of Contract price. Such proof shall be substantiated and submitted in writing to Architect/Engineer.
 - C. The Contractor shall submit a list of un-available plants and a list of all nurseries and plant brokers contacted, a maximum of 15 days after notification from the Construction Manager.

- D. The Architect/Engineer reserves the right to require the Contractor to replace at the Contractor's cost any plants which the Contractor has installed without the Architect/Engineer's approval.

1.09 PROOF OF PLANT AVAILABILITY

- A. These provisions shall not relieve the Contractor of the responsibility of obtaining specified materials in advance if special growing conditions or other arrangements must be made in order to supply specified materials. The Contractor shall secure all material and provide proof of such within 30 days of Notice to Proceed in order to guarantee plant availability at time of planting.
- B. Payment for procurement of plant material, including possible incidentals such as storage and maintenance at nursery after purchase, is the full responsibility of the Contractor.

1.10 SELECTION AND TAGGING OF PLANT MATERIAL

- A. The Contractor shall select and tag all stock plant material within 30 days of notice from the Construction Manager. Plant material which is not available, or not possible to contract grow shall be noted to the Architect/Engineer within 15 days of notice from the Construction Manager so substitutions may be selected. The Contractor shall source material from out of state or thru a plant broker if not locally available. The Contractor shall submit lists of all nurseries and plant brokers contacted for availability.
- B. Plants shall be subject to inspection and approval by the Architect/Engineer at place of growth or upon delivery for conformity to specifications. Such approval shall not impair the right of inspection and rejection during progress of the work. Wherever the terms "approve", "approval" or "approved" are used herein they mean approval of the Architect/Engineer in writing.
- C. Plants identified as "specimen" shall be approved and tagged at place of growth by Architect/Engineer. For distant material, submit photographs for pre-inspection review.

1.11 INSPECTIONS

- A. All plant material upon delivery to the job site:
 1. Notify the Construction Manager at least 7 Calendar Days prior to the time of the following required inspections:
 2. Plant material at the time of delivery to the job site.
 3. Landscape plants and construction items prior to the start of the Landscape Maintenance Period.
 4. Landscape plants and construction items at the end of the Landscape Maintenance Period.

1.12 VERIFICATIONS OF DIMENSIONS AND QUANTITIES

- A. Verify scaled dimensions and quantities prior to the start of work.
- B. Notify the Construction Manager of discrepancies between Contract Drawings and Contract Sections and actual job site conditions which would affect the execution of the landscaping work. Do not work in areas where discrepancies occur until instructed by the Construction Manager.
- C. Plant quantities noted on Contract Drawings are for the convenience of the Contractor only and do not limit the Contractor to those indicated quantities. Furnish the quantities as may be necessary for full coverage per Drawings, Schedules, and Details.

1.13 WARRANTIES AND GUARANTEES

- A. Landscape Maintenance Period (Two-Year per Section 329700):
 - 1. The Contractor guarantees all plant material under this Contract will be vigorous, healthy, free of dead or dying branches and branch tips, bearing foliage of normal density and color, and will otherwise comply with the Specifications noted in the Products Section of this Section, for a period of two years from the date of final acceptance.
 - 2. All plant materials determined by the Construction Manager to be untrue to the species, clone and/or variety specified, shall be replaced by the Contractor, to equal condition of adjacent plants at the time of replacement.
 - 3. B&B trees that die during the 24-month guarantee period and are deemed the responsibility of the Contractor shall be replaced by a B&B tree of the same variety and size at no cost to the DEP.
 - 4. The Contractor shall not be held liable for loss of plant materials during the guarantee period due to vandalism or accidental causes.
 - 5. Replacements shall be provided within 30 days of Notification of Rejection. Any delay in the completion of planting operations, which extends the planting into more than one growing season, shall extend the warranty period correspondingly.
- B. Replacements: Without cost to the DEP and as directed by the Construction Manager, replace all plants not meeting the requirements above during and at the end of the Landscape Maintenance Period within 30 days. The Contractor shall inspect all plant materials on a quarterly basis or if directed by the Construction Manager. Replacements shall closely match adjacent specimens of the same species in size and shall comply with all requirements of these Specifications. Plant replacements shall be the same size or larger than originally designated in the plans.

- C. Plant replacements shall be warranted for two years following the date of replacement. Plant replacements shall be completed within 30 days of notification of replacement from the Construction Manager and shall occur as many times as required by the Construction Manager within the Landscape Maintenance Period.

1.14 PRE-INSTALLATION CONFERENCE

- A. Convene pre-installation conference two months prior to installation of landscape soils and irrigation work. The Contractor shall have done prior to the meeting:
 - 1. Provide initial soil testing of the soils proposed to be used that have been reviewed and approved.
 - 2. Provide all information on the amendment procedures for the soil for review and discussion.
 - 3. Provide information on the methods and procedures for amending, placement and recording the placement of soil.
 - 4. Verify and demonstrate to the DEP that the soils will be uniformly mixed and amended to provide a consistent growing medium in planting beds throughout the entire duration of the project.
 - 5. Provide a schedule of work with timeline and drawings depicting sequencing of work. This information is to be used for inform Construction Manager of the sequencing of work.
 - 6. The meeting will be used to review the drawings with the Contractor.

1.15 DELIVERY, STORAGE, AND HANDLING

- A. Comply with requirements specified in Section 016100.
- B. Deliver plants in vehicles designed for that use.
- C. Handle plants only by means of their containers. Plants handled directly, with the weight of the plant supported by stem or branches or plants with damaged foliage or broken rootballs shall not be used.
- D. Store plants in a designated sheltered location or in special temporary facilities constructed to protect the plants from any deleterious effects of sun, shade, wind, heat or cold.
- E. Plants in containers shall be installed within one week of delivery to the job site.

- F. Package Materials: Deliver materials in packaging showing weight, analysis, and the name of the manufacturer. Protect materials from deterioration during delivery and storage on site.
- G. Trees and shrubs: Do not prune prior to delivery. Do not bend or bind-tie trees or shrubs in such a manner as to damage bark, break branches, or destroy natural shape. Provide protective covering during delivery.
- H. Deliver trees and shrubs after preparation for planting has been completed, and plant immediately. If planting is delayed more than 6 hours after delivery, set trees and shrubs in shade, protect from weather extremes and mechanical damage and keep the rootball moist.

1.16 SITE CONDITIONS

- A. Perform actual planting during those periods when weather and soil conditions are suitable in accordance with locally accepted horticultural practice.
- B. Perform planting only during the period when moisture is below field capacity.
- C. Repair or replace existing improvements which are not designated for removal which is damaged or removed as a result of the Contractor's operations.

PART 2 - PRODUCTS

2.01 CONTAINER PLANT MATERIAL

- A. Plants shall be as specified in the plant list on the plans and shall be healthy, vigorous stock, free of insects and disease in compliance with U.S.A. Standards for Nursery Stock. Use only plants materials that are first-class representations of the species and cultivars specified and that conform to all state and local laws governing the sale, transportation, and inspection of plant materials. Only healthy plants of suitable size and uniformity and species/variety indicated and only plants with a normal plant and root structure will be acceptable. Plants shall be guaranteed to arrive on the job site free of pests and diseases.
- B. All plants shall be nursery grown in accordance with good horticultural practices, and shall be grown under climatic conditions similar to those in the locality of the project for at least two years unless otherwise approved by the Landscape Architect.
- C. The Contractor is responsible for supplying plant material that has been properly acclimated and conditioned, in accordance with good horticultural practices, for the exposure, wind and humidity levels, soil conditions, etc. encountered at the project site and in the proposed plant locations.
- D. Plants shall be superior in form, compactness, and symmetry; sound, healthy and vigorous, well branched and densely foliated when in leaf. They shall be free of pests,

weeds and insects, insect eggs or larvae, diseases, sunscald injuries, abrasions or disfigurements, and free from physical damage of adverse conditions that would prevent thinning growth. They shall have healthy, well-developed root systems to the outside of each container without being root-bound in their containers. Specimens shall not demonstrate any damage due to containerization or staking. Tree tappers and calipers shall reflect appropriate staking methods.

E. Size:

1. Plants shall conform to the measurements specified. Measure plants when branches are in their normal position. Height and spread dimensions specified refer to the main body of plant and not branch tip to tip. Take caliper measurements at DMB approximately 36 inches above the natural ground line.
2. If a range of size is given, no plant shall be less than the minimum size and not less than 40 percent of the plants shall be as large as the maximum size specified.
3. The measurements specified are the measurements after pruning, where pruning is required. Plants that meet the measurements specified, but do not possess a normal balance between height, spread, and caliper, shall be rejected.
4. Plants larger than specified may be used if approved by the Architect/Engineer and if provided at no additional cost to the DEP. If larger plants are approved, the rootball shall be increased in proportion to the size of the plant; irrigation system shall also be adjusted as required to accommodate larger plants.

F. Species: All plant material shall be pre-selected and identified by tagging as specified herein prior to delivery to the site. Any plants not so identified will be subject to rejection by the Architect/Engineer. Replace all plant materials, determined by the Architect/Engineer within two years following the final acceptance of the project, to be untrue to the species, clone, and/or variety specified, to the equal condition of adjacent plants at the time of replacement, at no additional cost to the DEP.

G. Contractor shall remove the rejected plants and plant the replacement plants within 30 days of Notification of Rejection.

H. Trunks and Branches: Do not prune plants before delivery. All trunks are to be straight and of uniform taper, larger at the bottom unless otherwise specified. Plants with damaged or crooked leaders, or multiple leaders, unless specified, will be rejected. Plants with abrasions of the bark, sunscalds, disfiguring knots, or fresh cuts of limbs over 3/4 inch, which have not completely calloused, will be rejected. Any plant unable to stand upright without support will be rejected. The specimen shall not demonstrate any damage due to containerization or staking.

I. Rootball:

1. **Sizes:** As specified on the plans. Where no rootball dimensions have been specified, supply material in container sizes specified.
 2. **Material:** Rootball shall consist of a soil or soil mix that is compatible with the soil or soil mix into which the plant will be planted, and that provides for thorough drainage, aeration, and adequate moisture and nutrient retention. The rootball must be firm and well-rooted. It shall have sufficient density and firmness that when planted, the plant will stand upright and stable without the need for additional support.
 3. **Containers:** All plant material shall have been grown in the containers in which delivered for at least one year, but not over two years. Containers for trees shall be constructed to the specified dimensions in such a manner that the resultant rootball will approximate the slopes into which the individual tree(s) is to be planted.
 4. **Root Pruning:** Where root pruning is required to provide material of the specified size or for planting in the confined planters, the pruning is to be done under the direction of a Certified Arborist. No root pruning is to be done within one year of installation unless approved by the Architect/Engineer.
- J. Plant material that has been reviewed and selected at the place of growth by the Architect/Engineer does not constitute a waiver of the requirements of this Section, nor does it waive the Contractor's warranty responsibilities. The Contractor does not have the option to substitute for selected material unless selected material is rejected by the Construction Manager during the course of the work.
- K. The Contractor shall secure availability of all plant materials within 60 days after award of the contract.
- L. Flatted plants shall be grown and remain in the flat until transplanted at the job-site. The soil and spacing of the plants in the flat shall ensure the minimum disturbance of the root system at the time of transplanting. Maximum plants per flat shall be between 64 to 100 plants or as indicated on the Contract Drawings.

2.02 TREES

- A. Upon approval, all trees to be obtained by the Contractor shall comply with Federal and State laws requiring inspection for plant disease and pest infestations. Inspection certificates required by law shall accompany each shipment of plants. Clearance for the County Agricultural Commissioner, as required by law, shall be obtained before planting trees delivered from outside the County in which they are to be planted.
- B. **Tree Crowns**
1. **Trees designated as Standards:** Each tree that is described as a Standard shall have a single straight trunk that has not been headed and shall have a well-developed central leader, upright and of columnar character. All trunks are to be straight and

of uniform taper, larger at the bottom unless otherwise specified. Plants with damaged or crooked leaders or multiple leaders will be rejected.

- a. Branches shall be at least 6 inches apart vertically, radially distributed around the trunk and not be more than two-thirds the diameter of the trunk, measured at one inch above the branch. Branch attachments shall be free of included bark (bark embedded between the trunk and the lateral).
 - b. Branches shall not be more than two-thirds ($2/3$), (one-half is preferred), the diameter of the trunk, measured 1-inch above the branch.
 - c. No lateral branch below the lowest potential scaffold should be larger than one-fourth ($1/4$) the trunk diameter at the point of attachment.
 - d. Each tree must be branched per sub-article a, above, without having removed or having to remove, now or with the previous growing season (at least six months), more than twenty-five (25) percent of the branches of size similar to or larger than those of the potential scaffold branches.
2. Trees designated as Low-Branched or Multi-Stemmed:
 - a. Low-branched trees shall have a minimum of three radially-symmetrical main trunks that branch widely from the central base.
 - b. Main trunks shall not connect to individual root-balls. Trunks shall attach to a common basal trunk and branch at least eighteen inches above the soil line.
 3. The tree shall be able to stand upright without support and shall exhibit good wind resistance.
 4. Retain small (less than the $1/4$ -inch diameter of the trunk) temporary branches along the trunk below the scaffold branches.

C. Tree Roots

1. Contract grown trees shall be free of roots greater than one-fifth ($1/5$) the trunk diameter visibly circling the trunk, the free of “knees” (roots) protruding above the soil.
2. The rootball periphery should be free of circling roots larger than $1/4$ -inch in diameter or a mat of $1/4$ an inch or larger roots. Circling roots at the periphery of the rootball shall be the reason for rejecting a tree if they are large for the species and shoot growth is not acceptable for the species.
3. The trunk should not touch the top rim of the container.

4. The tree shall be well rooted in the soil media (substrate). Root distribution shall be uniform throughout the container media. Structure and growth shall be appropriate for the species/cultivar. When the container is removed, the root ball shall remain intact. When the trunk is lifted both the trunk and the root system shall move as one.
5. Growing period inspections shall include exposing the roots within 2-inches of the trunk to a depth of 2.5-inches below the topmost root attached to the trunk. The trunk should be free of circling roots and kinks in the main root(s). Trees exhibiting such conditions shall be subject to rejection. Soil washed from around trunk shall be replaced after inspection. The Select specimen may be un-banded to inspect a bottom portion of rootball. Re-banding to take place immediately following the inspection at no additional cost to the DEP.

D. Tree Size:

1. All trees shall be the container size, height, spread and caliper as indicated on the plant list on the Contract Drawings at the end of the growing period and upon installation.
2. Trees shall exhibit a normal balance between height, spread, and caliper.
3. Trees not meeting size requirements shall be subject to rejection.

E. Trees shall not be pre-dug, handled, or transported during adverse weather or during periods when season soil conditions or temperatures are unfavorable as determined by the Architect/Engineer.

2.03 TURF SOD

A. Sod shall be:

1. One year old and dense with grass, having been mowed at 1-inch height before lifting from the field.
2. Sod shall be cut from the field with a minimum of a one-half inch of soil that completely covers the roots of the sod. The sod shall have a healthy, virile root system of dense, thickly matted roots throughout.
3. All grown on fumigated soil. Sod shall be in vigorous condition, dark green in color, free of disease and harmful insects.
4. Sod shall be reasonably free of objectionable grassy and broadleaf weeds. Sod shall be considered weed free if no more than ten such weeds are found per 100 square feet of sod.

5. Sod shall be rejected if found to contain the following weeds: Common bermudagrass, quackgrass, Johnsongrass, poison ivy, nimbleweed, thistle, bindweed, bentgrass, perennial sorrel or brome grass.

2.04 MULCH

- A. Comply with provisions of Section 329400.

1. Organic Mulch

2.05 ANTI-DESICCANT

- A. For retarding excessive loss of plant moisture and inhibiting wilt; sprayable, water insoluble, vinyl-vinylidene complex, which will produce a moisture retarding barrier. Forming at temperatures commonly encountered out-of-doors during planting season. The film thus formed shall have an mvt (moisture vapor transmission rate) of not more than 10 grams per 24 hours at 70 percent humidity. Furnish evidence that the material can be used safely on plant materials specified.

2.06 PESTICIDES AND PRE-EMERGENT HERBICIDES:

- A. Selected from the broad spectrum of the commercial brands available subject to approval by the Architect/Engineer and not in conflict with regulations governing their use.

2.07 AMENDMENTS, FERTILIZERS AND CONDITIONERS

- A. Materials selected and used shall be compatible with amendments as determined by recommendations of Soil Testing Laboratory as described in Section 329113.

PART 3 - EXECUTION

3.01 PLANTING CONTAINER PLANTS

- A. Plant materials, including contract grown trees and plants previously approved at the nursery, shall be inspected prior to planting. The Contractor shall be responsible for the condition of plants, planted or otherwise, until final acceptance by the Construction Manager:
 1. Perform planting with materials and equipment in conformance to procedure favorable to the optimum growth of the plant. Do not plant during windy or frost conditions.
 2. Except as noted for specimen planting, start planting operations following the completion and approval of the irrigation system.

- B. Keep plant materials delivered to the site in healthy condition for planting. Do not allow plants to dry out.
- C. Layout and Plant Locations:
 - 1. Plant locations indicated on the Contract Drawings are approximate.
 - 2. Plants may be re-spotted prior to planting as directed by the Construction Manager, without additional compensation to the Contractor.
 - 3. Make a detailed layout of plants, in the planting areas and obtain approval of the Architect/Engineer prior to planting operations.
 - 4. Locate the first row of plants in areas designated for on-center spacing at 1/2 the designated spacing from the edge of the area.
- D. Plants in boxes (24 inches or larger) shall be planted before installation of lateral irrigation lines. Re-route irrigation lines in conflict with specimen plant locations to clear the rootball.
- E. Tree Planting:
 - 1. Make planting holes approximately square with vertical sides three times the width of the plant rootball or as indicated on the Contact Drawings.
 - 2. Do not plant plants with a broken or cracked rootball before or during planting.
 - 3. Open and remove plant containers so that the plant root is not injured.
 - a. Pruning damaged or inappropriate roots shall be done at this time as determined by the Construction Manager.
 - 4. Remove plant containers or wrappings after the plant is positioned in the planting hole.
 - 5. Backfill mix:
 - a. Amended topsoil per Section 329113, for soil depths of 24 inches. Assure that the backfill for planting pits below 12 inches in depth do not contain organic amendments or soil sulfur as described as the upper layer of amended soil under Section 329113, characteristics of the soil shall be similar to the lower 12-inch layer of soil as described in Soil Preparation. If additional backfill is necessary for depths lower than 12 inches have soils consist of similar qualities of lower level soils and incorporate Iron sulfate at a rate of 1 1/2 pounds per cubic yard of material. Caution: iron sulfate can stain moist concrete.

- b. Amendments and rates described under Section 329113. Exact materials and rates as determined by soils test results and recommendations by testing laboratory specified in Section 329113.
6. Trees should be set vertical on undisturbed subgrade. Set plumb and brace rigidly in position until planting soil has been tamped solidly around the balls and roots. When plant pits have been back-filled approximately 2/3 full, water thoroughly saturated rootball, before installing the remainder of planting soil to top of the pit, eliminating all air pockets. No organic amendment shall be included in soil backfill except for top one (1) foot layer.
 7. After "water settling" the bottom portion of the planting hole, set the plant approximately in the center of the planting hole and adjust the root crown two (2) inches above adjacent finish grade.
 8. Each tree in the line of trees shall be perfectly plumbed and aligned in a straight line relative to the rest of the trees.
 9. Backfill balance of the planting hole with the specified backfill mix and fertilizer and "water settle".
 10. Prune only to remove broken or damaged limbs.
 11. Form a 4-inch high circular watering basin slightly larger than the planting hole in all planting areas except lawns. Make the bottom of the basin at finish grade or slightly lower.
 12. Restore the area around the plants to finish grade and dispose of excess soil.
 13. After planting, plants shall be plumb with the root crown one and one-half inches above the adjacent finish grade.
- F. Shrubs and ornamental grasses:
1. Protect plants at all times from sun or drying winds. Plants that cannot be planted immediately on delivery shall be kept in the shade, well protected, and shall be kept well watered.
 2. Container stock shall be opened and removed in such a manner that the plant roots are not injured. A spade may not be used to cut cans. Plants shall be handled by earth ball only. Handling the plant itself may cause injury to the material. Special precaution should be taken to not break earth ball of all plants.
 3. Plants shall be set vertical on undisturbed subgrade and the crown shall be held above grade to the extent indicated on the Contract Drawings to discourage root-rot or other soil-borne diseases caused by having the crown at an inadequate elevation.

4. Use amended topsoil.
5. A slight saucer indentation around plants shall be formed around each shrub or ornamental grass plant at the time of planting to hold water.
6. Immediately after placing in the pit, backfill shall be watered then firmly tamped to ensure planting soil in and about all roots. No air pockets shall be left around roots of any plants. Thoroughly water after planting taking care not to cover crowns of plants with wet soil.

G. Ground Cover Planting:

1. Complete soil preparation, amending and fine grading prior to planting of ground cover materials.
2. Plant ground covers in moist soil, spaced as indicated on the Contract Drawings.
3. Plant each plant with its proportionate amount of flat soil to minimize root disturbance.
4. The degree of soil moisture in the flat shall be such that the soil does not crumble when removing the plant.
5. Following planting of ground cover, restore finish grade to ensure surface drainage.

3.02 MULCHING

- A. Apply mulch to lines, levels, and depths indicated on the Contract Drawings.

3.03 TURF SOD

A. Inspection:

1. Upon the completion of the placing of the soil and prior to placing sod, the Contractor shall call for an inspection of the turf irrigation system. The sod shall be placed after the Construction Manager has satisfied himself that the irrigation system is operating satisfactorily and finish grade is in accord with the Contract Drawings.

B. Laying Sod:

1. Remove all rubble, sticks, rocks and stones 1-inch or larger from top 2-inches amended soil.
2. Arrange for delivery of sod in the morning to insure same-day installation.
3. Lightly roll surface and re-shape to level humps and hollows. Secure Construction Manager's approval prior to sodding. Do not sod on dry soil.

4. Lay first strip of sod along a straight line (use a string in irregular areas). Butt joints tightly, do not overlap edges. On second strip, stagger joints. Use a sharp knife to cut sod to fit curves, edges and sprinkler heads.
 5. When a conveniently large area has been sodded, water lightly to prevent drying. Continue to sod and to water until installation is complete. Lay sod without stretching. Stagger end seams and butt edges as close as possible to each other. Roll with sod roller perpendicular to direction it was laid.
 6. After laying all sod, roll lightly to eliminate irregularities and to form good contact between sod and soil. Avoid a heavy roller and excessive initial watering.
 7. Thoroughly water the completed sod surface to at least 8 inches deep. Repeat sprinkling at regular intervals to keep sod moist at all times until rooted. After sod is established, decrease frequency and increase amount of water per application.
 8. Protect turf areas by erecting fences, barriers and signs necessary to prevent trespass. Keep barriers neat and well maintained.
 9. Apply post-planting fertilizer.
- C. At the time of final inspection, the turfs shall be dense, green, and weed free. It is the Contractor's responsibility to eliminate any bare spots, dead areas and weeds.

3.04 WEED CONTROL

- A. Weeds shall be kept under control, preferably either by hand or by NJDEP maintenance specifications. The application of herbicides shall be as last resort.
- B. All equipment used for herbicides, if utilized, shall be properly cleaned before it is used on this project. Herbicides shall be applied at temperatures recommended by the manufacturers. Herbicides shall not be used during windy or gusty days. All possible precautions shall be taken to protect vegetation which is susceptible to damage from the particular herbicides to be used.
- C. The bases of all plants shall be kept completely free of weeds. Periodically, the base of the trees and shrubs shall be cultivated in order to allow better penetration of water, but such cultivation shall be carefully done in order not to destroy surface roots.

3.05 WATERING

- A. Water plants immediately after planting.
- B. After the first watering, water shall be applied to all plants as conditions may require keeping the plants in a healthy and vigorous growing condition until completion of the Contract, without causing erosion detrimental to the planting area.

- C. Use soil probes to ensure the rootball, especially of B&B trees, and backfill is neither too wet or too dry.

3.06 CLEAN UP

- A. Keep all areas of work clean and neat at all times. Upon completion of planting, all cans, boxes, and other debris that is a part of the planting operation shall be removed from the site.
- B. All pavements shall be washed off, and site shall be left in an absolutely clean condition. All planting areas shall be cultivated and weed free before final inspection. Clean-up operations shall take place throughout the course of work so that walks and drives are clean at all time.
- C. Comply with the requirements of Section 017423.

3.07 FERTILIZING

- A. Lawn, grasses, and groundcovers Non-Synthetic Fertilization: Top dress all areas at 45-day intervals from time of planting with organic fertilizer or compost tea as recommended by soils report described in Section 329113. Water the area after applying fertilizer. Fertilizer applications shall be done under the inspection of the Construction Manager.
- B. For groundcover, trees, and shrubs, Non-Synthetic Fertilization: Top dress all areas at 45-day intervals from time of planting with organic fertilizer or compost tea as recommended by soils report described in Section 329113. Water the area after applying fertilizer. Fertilizer applications shall be done under the inspection of the Construction Manager.
- C. Fertilizing materials shall be reviewed by the soil testing laboratory who will determine final conformance of materials to be used in the fertilizing procedures.
- D. Before supplemental fertilizing the Contractor shall test all soils within planting zones to confirm soils are properly amended during construction. Testing shall be done within 30 days after plant installation but before the fertilizing program begins. The Contractor shall provide soils tests for every 5,000 square feet of planting bed. Fertilizing program will conform to the requirements of the recommendations of the testing laboratory.

3.08 MAINTENANCE OF PLANTING

- A. From the time any plants are planted until Final Acceptance of the Landscape Installation, the Contractor shall ensure that all plants be watered and fertilized, trash and debris kept removed, weeds controlled, erosion damage repaired, trees securely staked, and plant replacements made.
- B. Comply with all provisions of Section 329700.

3.09 FINAL INSPECTION AND ACCEPTANCE

- A. Upon completion of all landscape, planting and irrigation work under this Contract, and before the beginning of the formal 90-Day Establishment Period, the Pre-maintenance inspection shall be performed. Requirements of the Landscape Maintenance Period are specified in Section 329700.

3.10 CONTRACT CLOSEOUT

- A. Provide in accordance with Section 017700.

END OF SECTION 329300

SECTION 329400 - PLANTING ACCESSORIES

PART 1 - GENERAL

1.01 DESCRIPTION

- A. Provide planting accessories as indicated and in compliance with Contract Documents.
 - 1. Rootball Guying
 - 2. Organic Mulch
 - 3. Filter Fabric
 - 4. Drainage Gravel
 - 5. Tree Grates
 - 6. Root Barrier
 - 7. Metal Edge Restraint

1.02 PAYMENT

- A. No separate payment shall be made for performing any Work required under this Section. All costs for Work required by this Section shall be included in the applicable lump sum(s), as set forth in Section 012901.

1.03 REFERENCES

- A. American Society for Testing and Materials (ASTM):
 - 1. ASTM A53 / A53M Standard Specification for Pipe, Steel, Black and Hot-Dipped, Zinc-Coated, Welded, and Seamless.
 - 2. ASTM A123 / A123M Standard Specification for Zinc (Hot-Dip Galvanized) Coatings on Iron and Steel Products.

1.04 RELATED SECTIONS

- A. General Conditions Article 4.7 – Shop Drawings and Other Submittals.
- B. Section 012901 – Measurement and Payment.
- C. Section 014300 - Quality Requirements.
- D. Section 016100 - Control of Materials.
- E. Section 017700 - Contract Closeout.

- F. Section 329113 – Soil Preparation and Finish Grading
- G. Section 329200 – Turf and Grasses
- H. Section 329300 – Planting
- I. Section 329700 – Landscape Maintenance

1.05 SUBMITTALS

- A. Submit the following in accordance with General Conditions Article 4.7.
- B. Product Data: For each type of product indicated.
- C. Samples:
 - 1. Filter Fabric, minimum 2-foot square sample.

1.06 QUALITY ASSURANCE

- A. Comply with the requirements of Section 014300.
- B. Specifications for products that include manufacturer’s written instructions are described in this Section for the Contractor’s convenience. Actual components and installation instructions shall be based on the most currently available Manufacturer’s product literature unless otherwise noted.

1.07 VERIFICATIONS OF DIMENSIONS AND QUANTITIES

- A. Verify scaled dimensions and quantities prior to the start of work.
- B. Notify the Construction Manager of discrepancies between Contract Drawings and Contract Sections and actual job site conditions which would affect the execution of the landscaping work. Do not work in areas where discrepancies occur until instructed by the Construction Manager.

1.08 DELIVERY, STORAGE, AND HANDLING

- A. Comply with the requirements specified in Section 016100.
- B. Deliver all products and specified component parts to project site in appropriate protective packaging as furnished by the manufacturer. Packaging for each unit shall be clearly labeled.
- C. Notify the Construction Manager seven (7) calendar days prior to the time of delivery.

- D. Store units at project site to prevent exposure to weathering, vandalism or damage from work of other trades. Damaged materials will be rejected. Remove all damaged materials from the job site immediately and replace at no cost to the DEP.

PART 2 - PRODUCTS

2.01 ROOTBALL GUYING

A. Guying Materials

1. Guy Wire: #9 gage, galvanized twisted wire – clear plastic coated.
2. Deadman: Provide one of the following available products:
 - a. Duckbill Earth Anchoring System. As provided by Maclean Civil Products; 481 Munn Road, Suite 300, Fort Mill, SC 29715; Telephone: 800-325-5360; Web: <http://www.earthanchor.com/duckbill/>
 - 1) Model 40 DTS for trees up to 2-inch caliper.
 - 2) Model 68 DTS for trees up to 6-inch caliper.
 - 3) Model 88 DTS for trees up to 11-inch caliper.
 - b. Platipus Anchoring Systems. As provided Platipus Anchors Inc.; 1902 Garner Station Boulevard, Raleigh, NC 27603; Telephone: 919-662-0991; Web: <https://www.platipus.us/>
 - 1) Model G1 for trees 8 to 15 feet in size / 1 ½” to 3” caliper.
 - 2) Model G2 for tree 15 to 25 feet in size / 3” to 5 ¾” caliper.
 - 3) Model G3 for trees 25 to 40 feet in size / 5 ¾” to 9 ½” caliper.
 - 4) Model G4 for trees over 40 feet in size / over 9 ½” caliper.
 - c. Greenblue ArborGuy Anchors; 4405 Anderson Road, Knoxville, TN 37918; Telephone: 866-282-2743; Web: www.greenblue.com
 - 1) Drive-In Anchor up to 8 inch caliper
 - 2) Drive-In Anchor up to 16 inch caliper
 - d. Or approved equal.
3. 1-inch dia. eyebolt attached to concrete curbing and/or interior side of custom fabricated metal planter boxes.
4. Hose – 3/4-inch reinforced black, rubber garden hose.
5. Warning Guy Wire Tube – 5-long, 1/2-inch diameter white Class 315 PVC pipe.
6. Turnbuckles – 6-inch long, galvanized eye/hook type.
7. Wire Clamps – 3/4-inch galvanized “U” clamps.

B. Rootball Tree Stabilization Materials:

1. All trees 1.5-inch caliper and larger shall be stabilized utilizing a proprietary rootball stabilization device utilizing a rootball strap attached to below-grade deadmen. Rootball strap shall be of a material that will not damage rootball; metal cable systems are not acceptable. Rootball guying system to be sized per manufacturer's written recommendations unless otherwise indicated. All trees smaller than 1.5-inch caliper shall not be staked or utilize rootball guying.
 - a. Products: Provide one of the following available products:
 - 1) Tree Ball Anchoring System, Platipus Anchors Inc.; As provided Platipus Anchors Inc.; 1902 Garner Station Boulevard, Raleigh, NC 27603; Telephone: 919-662-0991; Web: <https://www.platipus.us/>
 - a) Model RF0P 4 Leg for trees 12 inches box / 8 feet in height/caliper up to 1 ½ inches.
 - b) Model RF1P 4 Leg for trees 12 inches to 24 inches box / 8 to 15 feet in height / 1 ½ inches to 3 inches caliper.
 - c) Model RF2P 4 Leg for trees 24" to 48" box / 15 to 25 feet in height / 3 inches to 5 ¾ inches caliper.
 - d) Model RF3P 4 Leg for trees 48" to 60" box / 25 to 40 feet in height / 5 ¾ inches to 9 ½ inches caliper. The system can rootball guy palm trees with height up to 20 feet and with rootball sizes of 48 inches to 60 inches box
 - e) Model RF4P 4 Leg for trees over 60" box/trees over 40 feet in height / 9 ½ inches caliper. The system can rootball guy palm trees height 20 to 40 feet and with rootball sizes over 60 inches box
 - 2) Duckbill Root Ball Fixing System; As provided by Maclean Civil Products; 481 Munn Road, Suite 300, Fort Mill, SC 29715; Telephone: 800-325-5360; Web: <http://www.earthanchor.com/duckbill/>
 - a) Model 40 RBK for trees up to 2-inch caliper.
 - b) Model 68 RBK for trees up to 3-inch caliper.
 - c) Model 88 RBK for trees up to 6-inch caliper.
 - 3) Greenblue ArborGuy Anchors; 4405 Anderson Road, Knoxville, TN 37918; Telephone: 866-282-2743; Web: www.greenblue.com
 - a) Drive-In Anchor up to 8-inch caliper
 - b) Drive-In Anchor up to 16-inch caliper
 - 4) Or approved equal.

2.02 ORGANIC MULCH

- A. Organic Wood Mulch: Free from deleterious materials and suitable as a top dressing of trees and shrubs, consisting of one of the following:
1. Organic Wood Mulch shall be double-shredded well-composted, hardwood bark, aged nine (9) months to one (1) year. Particle size shall be two inches (2”) or less in any dimension with less than thirty percent (30%) comprised of fines. Mulch shall be free of wood chips, stones or other undesirable matter. Mulch shall be natural color.
 2. Post-consumer materials, such as pallets, and dyes shall not be permitted.

2.03 FILTER FABRIC

- A. Non-woven geotextile manufactured for separation applications and made of polypropylene, polyolefin, or polyester fibers or combination of them.

2.04 DRAINAGE GRAVEL

- A. Washed, sound crushed stone or gravel complying with ASTM D 448 for Size No. 8.

2.05 TREE GRATES AND FRAMES

- A. Products: Provide one of the following available products:
1. Tree grates and frames. As provided by Canterbury Designs; 5632 W Washington Blvd., Los Angeles, CA 90016; Telephone: 323-936-7111; Email: info@canterbury-designs.com; Web: www.canterbury-designs.com
 - a. Ring Tree Grate – 4’ Square. TGRI-4-SQ.
 - b. Square Tree Grate Frame 48”. CDSTGF 48
 2. Tree grates and frames. As provided by IRON AGE DESIGNS; 2104 SW 152nd St. #4, Burien, WA 98166; Telephone: 206-276-0925; Fax: 206-257-0318; Web: www.ironagegrates.com
 - a. Spin 4’x4’ Heel Proof Tree Grate
 3. Tree grates and frames. As provided by Neenah Foundry; 2121 Brooks Ave. Neenah, WI 54956; Telephone: 920-725-7000; Fax: 920-729-3661; Web: www.nfco.com
 - a. Avenue 4’ Square Tree Grate
 4. Or approved equal.
- B. Tree grates material shall be cast aluminum from 100 percent recycled material. All tree grate castings shall be manufactured true to pattern and component parts and shall fit together in a satisfactory manner. The castings shall be of uniform pattern and quality,

free from blowholes, hard spots, shrinkage, distortion or other defects. Castings shall be cleaned by shot blasting.

- C. Finish: Grates are to be supplied in unfinished natural/raw state.
- D. Matching steel angle frames provided by tree grate manufacturer.
 - 1. Frames to be provided in unfinished natural/raw state.

2.06 ROOT BARRIER

- A. Tree Root Barrier, Vertical & Horizontal applications: Plastic mechanical barrier in modular panels or sheet rolls used to redirect and guide tree roots away from hardscape surfaces, biofiltration systems, and infrastructure elements.
- B. Products: Provide one of the following available products as appropriate per the Contract Drawings and as approved by the Architect/Engineer:
 - 1. As provided by DeepRoot Green Infrastructure, LLC. (DeepRoot), 530 Washington Street, San Francisco, CA 94111; Telephone: 800-458-7668; Fax: 800-277-7668; Web: www.deeproot.com
 - a. UB 24-2 24" Tree Root Barrier
 - b. UB 36-2 36" Tree Root Barrier
 - c. UB 48-2 48" Tree Root Barrier
 - 2. As provided by NDS, Inc. 851 North Harvard Avenue, PO Box 339, Lindsay, California 93247; Telephone: 800-726-1994; Fax: 800-726-1998; Email: nds@ndspro.com; Web: www.ndspro.com
 - a. EP-2450 24"x24" Root Barrier Panel
 - b. EP-3650 36"x24" Root Barrier Panel
 - c. SM2420 24"x20' Root Barrier Roll
 - d. SM3620 36"x20' Root Barrier Roll
 - e. SM4820 48"x20' Root Barrier Roll
 - 3. As provided by Century Products. 1144 N. Grove Street, Anaheim, CA 92806; Telephone: 714-632-7083; Web: www.centuryrootbarrier.com
 - a. CP2424 24" Root Barrier Panel
 - b. CP3624 36" Root Barrier Panel
 - c. CP4824 48" Root Barrier Panel
 - d. CR2420/3620 Root Barrier Roll
 - 4. Or approved equal.

2.07 METAL EDGE RESTRAINT

- A. Metal edge restraint with 0.210 inch (5.33 mm) thick exposed top lip x 8 feet (2.44 meters) long, extruded aluminum, alloy 6005, T-5 hardness. Horizontal base to have upward facing angle profile designed to integrate restraint and asphalt surfaces for straight-line and curvilinear applications. Section shall have holes in base spaced 4 inches (102 mm) apart along its length to receive anchors. Metal edge restraint height to relate to adjacent planted conditions as documented in the Contract Drawings, and as in Section 329200, Section 329300, and Section 329700.
- B. Connection Method: Section ends shall splice together with horizontal 0.060 inch (1.52 mm) thick x 1 inch (25 mm) wide, or 0.530 inch (13.5 mm) wide for 1 inch (25 mm) high edging x 4 inches (102 mm) long aluminum sliding connector.
- C. Anchors: 3/8-inch x 10 inches (9.5 mm x 254 mm) bright spiral steel spike, 3/16-inch x 1-1/2 inches (4.8 mm x 38 mm) or longer concrete nail, or drive pin fastener equal to Hilti DX 40 powder actuated pin or Ramset Trakfast Automatic Fastening System pin.
- D. Finish: Mill Finish. Paint finish shall comply with AAMA 2603 for electrostatically baked on paint.

PART 3 - EXECUTION

3.01 ROOTBALL GUYING

- A. Complete guying immediately after planting. Securely guy all rootballs in accordance with the Contract Drawings. Remove all nursery stakes unless recommended otherwise.

3.02 CONTRACT CLOSEOUT

- A. Provide in accordance with Section 017700.

END OF SECTION 329400

NO TEXT ON THIS PAGE

SECTION 329700 – LANDSCAPE MAINTENANCE

PART 1 - GENERAL

1.01 DESCRIPTION

- A. After the completion of 90-day establishment period for landscape planting and irrigation, work has been completed, reviewed and accepted by the DEP, furnish materials, labor, transportation, services, and equipment necessary to provide landscape maintenance as indicated and in compliance with Contract Documents.
 - 1. Continuous maintenance of plant material and irrigation system during specified landscape maintenance period. Maintenance practices shall be employed to minimize waste, protect air and water quality, conserve energy and water, and protect natural ecosystems.
 - 2. This work shall include all supervision, labor, materials, equipment, tools, supplies and services to maintain in a superior condition all landscape areas, irrigation, and drainage systems and other related work. All work shall be performed in a workmanlike manner, using quality equipment.

1.02 PAYMENT

- A. No separate payment shall be made for performing any Work required under this Section. All costs for Work required by this Section shall be included in the applicable lump sum, as set forth in Section 012901.

1.03 REFERENCES

- A. “Arboriculture: Care of Trees, Shrubs and Vines in the Landscape” by Richard W. Harris, Prentice-Hall, Inc., 1983.

1.04 RELATED SECTIONS

- A. General Conditions Article 4.7 – Shop Drawings and Other Submittals.
- B. Section 012901 – Measurement and Payment.
- C. Section 014300 - Quality Requirements.
- D. Section 016100 – Control of Materials
- E. Section 017423 – Cleaning Up.
- F. Section 017700 - Contract Closeout.
- G. Section 328400 – Planting Irrigation.

- H. Section 329113 – Soil Preparation and Finish Grading.
- I. Section 329300 – Planting.
- J. Section 329400 – Planting Accessories.

1.05 SUBMITTALS

- A. Submit the following in accordance with General Conditions Article 4.7.
- B. Landscape Maintenance Management Plan: Submit for review and approval the sequencing of work to be provided during the landscape maintenance period. The Contractor shall provide:
 - 1. Work Plan with including work tasks, inspections, and testing during:
 - a. Weekly operations
 - b. Monthly operations
 - c. Quarterly operations
 - d. Yearly Completion and Closeout.
 - 2. Provide information including:
 - a. Watering Plans and Schedules
 - b. Weed Control Methods and Schedules
 - c. Integrated Pest Management Methods and Schedules
 - d. Fertilization Schedules
 - e. Plant Replacement and Maintenance
 - f. Mulch Replacement and Protection
 - 3. Provide dates and times when the operations will be provided under this scope of work.
 - 4. Provide the number of crews including the number of staff required to do each task.
 - 5. Provide a list of equipment required to provide services. All equipment must be suitable for use and will not cause damage to pavements or other elements to the site and building.

6. Provide security and pedestrian/traffic control plans providing measures to manage operations of the maintenance.
 7. Provide schedule when major testing and inspections including but not limited to:
 - a. Soil.
 - b. Pest Control
 8. Provide in management plan when Construction Manager will be needed to assess conditions of planting.
- C. Closeout submittals:
1. Annual Full Water Use Audit with Record Precipitation Rate. Provide water use by planting hydrozone to determine water use efficiency for the Project.
 2. Post Soil Testing: Provide comprehensive soil testing for all planting beds 30 days before closeout. Provide testing for every soil test for every 10,000 square feet of planted bed
 3. Maintenance Procedure and Operations Manual: Provide for closeout operations manual for maintenance of landscape work for a (2) two-year period. This manual to include but not limited to:
 - a. Post soil amendment procedures
 - b. Fertilization Periods.
 - c. Plant trimming and cutting procedures and timing.
 - d. Maintenance procedures for each plant type.
 4. Provide documentation for the purchase and delivery of:
 - a. Planting soils.
 - b. Organic Amendments.
 - c. Pesticides.
 - d. Organic Mulches.
 - e. Plant replacements
 5. Replacement logs of plant material with locations.

1.06 LANDSCAPE MAINTENANCE PERIOD

- A. Landscape Maintenance Period Duration: from Final Acceptance by DEP of all planting work and after 90-day establishment. The Contractor may at the discretion of the Construction Manager, be allowed to proceed into landscape maintenance period if planting and irrigation are deemed "substantially complete" by the Construction Manager.
 - 1. Request an observation of Work by the Construction Manager to begin landscape maintenance period after planting and related work has been completed in accordance with Contract Documents. A prime requirement is that planting beds show a consistent and healthy appearance.
- B. Continuously maintain all planting areas during the progress of Work and during landscape maintenance period until satisfactory completion of the landscape maintenance period has been authorized.
 - 1. Improper landscape maintenance or possible poor condition of planting at the termination of the scheduled landscape maintenance period may cause landscape maintenance period to be continued at no cost to the DEP.
 - 2. In order to carry out landscape maintenance work, furnish sufficient workers and adequate equipment to perform Work during the landscape maintenance period.
 - 3. Any day that the Contractor fails to adequately perform landscape maintenance, as determined necessary by the Construction Manager, that day will not be credited as one of landscape maintenance working days.
 - 4. Prior to being placed on landscape maintenance, submit a schedule of activities planned during the landscape maintenance period. The Contractor is to provide the DEP with weekly, monthly, quarterly and annual work schedules describing the work to be performed in the Project Area. These schedules must be accepted by the Construction Manager prior to the start of landscape maintenance. Document schedule changes and obtain acceptance by the Construction Manager.

1.07 SAFETY

- A. The Contractor must at all times exercise necessary precautions to provide for the protection of the public and employees.
- B. All services rendered shall be provided in accordance with all ordinances, resolutions, statutes, rules, laws, and regulations any Federal, State, or local government having jurisdiction in effect at the time service is provided.
- C. Any non-emergency work that may be deemed hazardous or disruptive (i.e., chemical spraying, tree pruning, etc.) shall be scheduled at least two (2) weeks in advance with the Construction Manager. For emergency work, the Contractor must obtain written approval from the Construction Manager prior to commencing work.

- D. Chemical Applications: IPM uses cultural, mechanical, physical, and biological control methods before using pesticides. Chemical controls are applied only when monitoring indicates that preventative and non-chemical methods are not keeping pests below acceptable levels. When pesticides are required, the least toxic and the least persistent pesticide that will provide adequate pest control is applied.
- E. The Contractor shall apply all chemicals in a safe manner and according to label instructions and the DEP, State and Federal requirements. The Contractor shall mix and apply chemicals to protect against accidental spills and drift to non-target areas, and to ensure the safety of the applicator. Any spilled chemicals, as well as contaminated soil, water, and/or landscape materials, must be removed from the Project and disposed of in accordance with the DEP requirements. The Contractor shall maintain applicator's licenses and records of applications as required by the State.
- F. A Chemical Work Report shall be completed for each chemical application. The Contractor is responsible for submitting chemical usage reports to the County Agricultural Department. Copies are to be sent to the Construction Manager as part of the Contractor's monthly report.

1.08 TESTING – HORTICULTURAL SOILS TEST

- A. The Contractor shall collect and submit soil samples to an accredited and approved testing laboratory. Sample collection procedures shall adhere to recommendations of the soil testing laboratory. The Contractor shall request that the laboratory make recommendations based on an 'organic' approach to soil and landscape management. Submit soil lab report and any proposed soil amendments and cost adjustments to the Construction Manager for written approval. After review and written approval by the DEP, amend the soils according to said laboratory's recommendations. The approved soils laboratory recommendations shall be considered a part of this specification. Analyses to be performed include: pH, electrical conductivity, nitrate, ammonium, phosphorus, potassium, calcium, saturation percent, sodium, chloride, sodium adsorption ratio, boron, percent sand-silt-clay, lime, percent organic
- B. The Contractor shall determine infiltration rate and drainage characteristics within the Project. This information shall be considered when scheduling irrigation.

PART 2 - PRODUCTS

2.01 GENERAL

- A. Provide materials used during landscape maintenance work in accordance with the requirements of the Contract Sections.

2.02 FERTILIZATION

- A. Landscaping relies on organic fertilizers and soil amendments from natural sources that release elements slowly, which shall be preferred.
- B. Additional amendments and fertilizers that are approved for use by the Organics Materials Research Institute (OMRI) for use in crop production are approved for use in the landscape. See www.omri.org. The Contractor must supply fertilizer and soil amendment labels including the guaranteed analysis identifying components of the material and the percent nutrient content. The Contractor is required to apply the appropriate amount of fertilizer to supply the specified quantity of nutrient as determined by soil analysis and/or plant tissue analysis. Fertilizers selected shall have lower toxicity, persistence, and bioavailability. Contractor shall provide documentation demonstrating how lower toxicity, persistence, and bioavailability were incorporated into the choice of the selected fertilizers.
- C. The Contractor shall apply and manage fertilizers and amendments to prevent pollution of surface and groundwater and to avoid creating a nitrogen draft in the soil or toxicity to plants.
 - 1. Restricted materials. Fertilizers that are not approved or are restricted for use in crop production by OMRI shall be applied only after review and written approval by the Architect/Engineer.

PART 3 - EXECUTION

3.01 LANDSCAPE MAINTENANCE

- A. Keep landscape areas free of debris. Provide clean up at intervals of not more than 10 days.
- B. Keep planted areas weed-free. Cultivate at intervals of not more than 10 days.
- C. Maintain adequate protection of Work area. Repair damaged areas. Install temporary protection fences, barriers, and signs as required for protection.
- D. Repair eroded areas, restoring topsoil to original grade, replacing damaged plant materials and replacing mulch as necessary.
- E. Sweep clean paved areas at weekly intervals, or more frequently, if deemed necessary.
- F. Maintain organic mulch. The Contractor shall maintain a minimum of 2 inches of course organic mulch at all times over soil surface that is not covered by vegetation. Mulch shall be applied so that it is below grade (curb, edging, etc.) by half an inch. Some additional grading preparation and grading of areas adjacent to sidewalks or edging, etc. may be

required to keep the finish grade of the mulch at an appropriate level. Mulch materials shall be as specified in Section 329400.

- G. Leaf litter and clippings. To conserve nutrients on-site and protect the soil surface, The Contractor shall retain natural leaf drop under trees or in shrub beds. Select only tree and shrub beds or other area designated by the DEP that will not allow leaf litter or mulch to wash out into storm drains. Where leaf litter detracts from landscape appearance due to large leaf size, it is preferable that leaves be chopped and returned to landscape beds. Remove diseased leaves that would provide inoculums for plant infection.
- H. Fertilization Application frequency: Fertilizers shall be applied on a prescription base only. Application frequency shall be determined by plant need and assessed through soil and/or tissue analyses. For bidding purposes, the following maximum annual number of applications are provided.
 - 1. Shrubs, woody ground covers: One time per year
 - 2. Herbaceous ground covers, perennials Two times per year
 - 3. Annuals: Four times per year
- I. Plant Replacement: Contractor shall inspect all plant materials during the Landscape Maintenance Period on a quarterly basis, at a minimum or as directed by the Construction Manager. During the 90 Day Establishment Period Inspections shall be performed more frequently and, If plant material is deemed to be of poor quality, as determined by the Construction Manager, plants shall be removed and replaced in kind. Replacement plantings shall be warranted for one additional growing season beyond the original landscape maintenance period two-year warranty. All costs associated with the replacement and maintenance of plantings shall be the responsibility of the Contractor and covered under the two-year warranty. The two-year warranty shall be considered incidental to the original lump sum item associated with the respective planting.
 - 1. Tree or shrub material that is deemed to be more than 25 percent dead, unhealthy, or disfigured, as determined by the Construction Manager, shall be considered unacceptable and shall be replaced. Plants are considered disfigured when excessive dead wood has been removed or when the symmetry, typical habit of growth, or sculptured form has been impaired by the removal of dead wood.
 - 2. Replacement plantings to replace unacceptable plants shall be in accordance with the Specifications. Unacceptable plantings shall be removed within 2 days of notification that they are deemed unacceptable. Prior to removal, Contractor shall mark up a planting plan indicating the exact location of replacement and the anticipated planting date of replacement plants. Replacement plantings shall be planted within 30 days of notification and in accordance to the specified planting periods. If plants cannot be replaced within 30 days of notification due to seasonal

conditions, replace plants no later than the next succeeding planting season as described herein, with acceptance from Construction Manager.

3.02 TREE AND SHRUB CARE

A. Watering:

1. Maintain a large enough water basin around shrubs so that enough water can be applied to establish moisture through the major root zone.
2. When hand watering, use a water wand to break water force.
3. Replenish wood mulches to reduce evaporation and frequency of watering.
4. Regulate irrigation watering times to minimize erosion and gullyng.

B. Tree Pruning:

1. Selectively develop permanent scaffold branches that are smaller in diameter than trunk or branch to which they are attached which have vertical spacing of from 18-inches to 48-inches and radial orientation so as not to overlay one another.
2. Eliminate diseased or damaged growth.
3. Eliminate narrow V-shaped branch forks that lack strength.
4. Reduce toppling and wind damage by thinning out crowns.
5. Remove sucker growth.
6. Maintain growth within space limitations.
7. Maintain a natural appearance and to balance crown with root mass.
8. Treatment of lower branches:
 - a. Stripping of lower branches ("raising-up") of young trees will not be permitted, unless instructed otherwise.
 - b. Retain lower branches in a pinched ("tipped-back") condition with as much foliage as possible to promote caliper trunk growth.
9. Cut lower branches flush with trunk only after tree is able to stand erect without staking or other support and only when recommended by Architect/Engineer.

C. Shrub Pruning:

1. The overall objective of shrub pruning is the same as for trees.

2. Do not clip shrubs into balled or boxed forms unless approved initially by the Architect/Engineer.
 3. Make pruning cuts on lateral branches or buds flush with the trunk. Do not “stub” branches.
- D. Replacement of Plants: Replace dead, dying and missing plants with plants of like size and condition to those that were originally installed at no cost to the DEP.

3.03 ORNAMENTAL GRASS CARE

- A. Cutting Back: Cut back to rejuvenate plants, to remove brown, unsightly seed heads, or at time of dormancy as necessary. Cut back from 1/4 to 1/2 of clump height and as recommended by the Architect/Engineer.
- B. Weed Control: Control weeds by hand so as to cause minimal damage to plant materials.
- C. Watering: Water once a week thoroughly; twice a week in hot summer heat spells. Several water cycles start must be programmed in order to thoroughly wet the soils.

3.04 GROUND COVER CARE

- A. Weed Control: Control weeds with chemical systemic spray or by hand so as to cause minimal damage to plant materials.
- B. Watering: Water enough so that moisture penetrates throughout the root zone and only as frequently as necessary to maintain healthy growth.
- C. Edge ground cover to keep in bounds and trim top growth as necessary to achieve an overall even appearance.

3.05 WEED AND PEST CONTROL

- A. Keep planted areas free of weeds.
 1. Use recommended legally approved herbicides.
 2. Avoid frequent soil cultivation that destroys shallow surface roots.
 3. Replenish lost wood mulch to reduce weed growth.
- B. Insect and Disease Control: Maintain insect and disease control during landscape maintenance period.

3.06 FERTILIZATION

- A. Fertilization: Fertilize planting areas as recommended from soil tests obtained under Section 329113.

3.07 PLANT REPLACEMENT

- A. Replace dead, dying and missing plants with plants of like size and condition to those that were originally installed at no cost to the DEP. Plant replacement shall conform to the original planting procedures identified under:
 - 1. Section 329300 – Planting
 - 2. Section 329400 – Planting Accessories

3.08 IRRIGATION SYSTEM

- A. Provide maintenance of irrigation system consisting of cleaning and adjusting sprinkler nozzles, repairing damaged equipment, servicing valves, programming controllers and other activities required during the landscape maintenance period.
- B. Irrigation scheduling – water budget method. The water budget approach to irrigation scheduling shall be used to match plant need with water application and avoid over-irrigation and overspray.
 - 1. Irrigation intervals and frequency shall be suitable for weather conditions, soil infiltration rates, and plant species' rooting depth and water requirements within each hydrozone.
 - 2. Irrigation frequency shall be based on ET (evapotranspiration) data (available through the New Jersey NRCS Irrigation Guide. Irrigation shall be applied at approximately 60 percent allowable depletion (AD) for turf and annuals, 70 percent for non-drought tolerant and 90 percent for drought-tolerant plantings.
 - 3. Irrigation duration within each hydrozone shall be based on the soil infiltration rate, species water requirement and rooting depth within the hydrozone, and the application rate and distribution uniformity of the irrigation system within that zone. Enough water shall be applied at each irrigation cycle to wet through the depth of the root zone. Where runoff occurs, the application time shall be divided into shorter time intervals and repeated as needed.
 - 4. Irrigation frequency for each hydrozone shall be adjusted a minimum of every four weeks to reflect ET expected in the next month.
 - 5. For sites with controllers that monitor ET and adjust schedules automatically, the Contractor shall program the controller according to manufacturer specifications and monitor to ensure that frequency is appropriate.
 - 6. Whenever possible, landscape irrigation shall be scheduled between 2:00 a.m. and 10:00 a.m. to avoid irrigating during times of high wind or high temperature.
- C. Irrigation system maintenance and repair

1. The Contractor shall maintain the irrigation system for optimum performance, as per the manufacturer's specifications, by inspecting the entire system on an ongoing basis. This includes cleaning and adjusting all sprinkler and bubbler heads, drip emitters and valves for proper coverage. See Section 328400 for Planting Irrigation.
2. The Contractor shall inspect the irrigation system in operation to ensure proper function according to the following schedule:
 - a. April – October Weekly
 - b. November – March Monthly (when system operating)
3. All malfunctioning equipment shall be repaired prior to the next scheduled irrigation.
4. All irrigation replacement parts shall be of the same manufacturer, type, and application rates as existing, or approved equals or upgrades.
5. Irrigation system pressure shall be checked and adjusted at least monthly during the season of operation.
6. Twice a year, at a minimum, the Contractor shall:
 - a. Ensure all flush valve/cap locations are visible.
 - b. Ensure valve boxes are visible and can be opened.
 - c. Inspect valves, filters, and pressure regulators for damage or leaks. Check wire splices.
 - d. Clean valve boxes of dirt and debris.
 - e. Flush filters. A hose can be attached to the flush cap to keep water out of the valve box.
 - f. Inspect and clean filters. Replace damaged or torn filters.
 - g. Flush laterals.
 - h. Make sure plants have adequate numbers of drip emitters for their size.
 - i. Test backflow preventers.
7. Sprinkler heads shall be modified as needed to avoid overspray.
8. Where possible and appropriate, recommend to the DEP where sprinklers could be converted to drip or bubblers.

9. The Contractor shall maintain and submit monthly documentation of irrigation checks and update the as-built plans with any changes or adjustments to the system.

3.09 EROSION AND WEAR REPAIR

- A. Replace topsoil lost to erosion, rutting, wearing and dislocation.
- B. Repair eroded, rutted, and damaged decomposed aggregate surfacing areas.
- C. Restore finish surface to smooth, even condition with no rutting, abrupt grade changes or unevenness.
- D. Place and re-compact topsoil in compliance with placement and compaction requirements as specified in Section 329113.

3.10 FINAL WALK-THROUGH

- A. At the completion of the landscape maintenance period, schedule a Final Walk-Through with the Construction Manager.
- B. The DEP, Contractor, and others deemed necessary by the Construction Manager may be present at the Final Walk-Through.
- C. If during the Final Walk-Through the Construction Manager is of opinion that landscape maintenance has been substantially completed in accordance with this Section, written notice of recommendation to allow the Contractor to be released from Project will be submitted to the DEP for approval. This report will note any incomplete punch list items from Final Walk-Through and a date on which these items must be completed. Complete remaining punch list items within 5 working days after the Final Walk-Through was performed by the Construction Manager.

3.11 CLEANUP

- A. Comply with the requirements of Section 017423.
- B. Upon completion of landscape maintenance, remove rubbish, waste, and debris resulting from the Contractor's operations.
- C. Repair scars, ruts or other marks in landscaped areas caused by the Contractor.
- D. Remove equipment, implements of service and leave Work area in a neat and clean condition as accepted by the Construction Manager. Sweep clean paved areas.

3.12 CONTRACT CLOSEOUT

- A. Provide in accordance with Section 017700.

END OF SECTION 329700

SECTION 331000 - WATER UTILITIES

PART 1 - GENERAL

1.01 DESCRIPTION

- A. Replace water utilities as indicated and in compliance with Contract Documents.
- B. Section includes:
 - 1. Replacement of water line pipe and fittings.
 - 2. Replacement of water line valves, fire hydrants, accessories, services and appurtenances.
 - 3. Installation of line stop valves and steel pipe for temporary bypass.
 - 4. Performing pressure and leakage tests.
- C. In Jersey City, only a pre-qualified contractor approved by the Utility may perform this work. Jersey City pre-qualified contractors include:
 - 1. J.F. CREAMER & SON, INC.
1701 East Linden Avenue
Linden, New Jersey 07036
Telephone (908) 986-5717
Ted Paliwoda
Cell (201) 481-7018
Tpaliwoda@JFCson.com
 - 2. JOSEPH M. SANZARI, INC.
90 West Franklin Street
Hackensack, New Jersey 07601
Telephone (201) 342-6895
Psarlo@sanzaricompanies.com
 - 3. MONTANA CONSTRUCTION
80 Contant Avenue
Lodi, New Jersey 07644
Telephone (973) 478-5200
dcarnevale@montanaconstructioninc.com
- D. Only a pre-qualified contractor approved by the Utility may construct line stops. Pre-qualified contractors include:
 - 1. GARRISON ENTERPRISE INC.
211 West Elmer Road
Vineland, New Jersey 08360
Edward Basolis
Telephone (856) 692-6696
Elbert@Basolis.com

E. In Weehawken, only a pre-qualified contractor approved by the Utility may perform this work. Weehawken pre-qualified contractors include:

1. J.F. CREAMER & SON, INC.
1701 East Linden Avenue
Linden, New Jersey 07036
Telephone (908) 986-5717
Ted Paliwoda
Cell (201) 481-7018
Tpaliwoda@JFCson.com
2. JOSEPH M. SANZARI, INC.
90 West Franklin Street
Hackensack, New Jersey 07601
Telephone (201) 342-6895
Psarlo@sanzaricompanies.com
3. MONTANA CONSTRUCTION
80 Contant Avenue
Lodi, New Jersey 07644
Telephone (973) 478-5200
dcarnevale@montanaconstructioninc.com

1.02 PAYMENT

A. All costs for Work required by this Section shall be included in the applicable lump sum(s), unit price(s), or allowance(s) as set forth in Section 012901.

1.03 RELATED SECTIONS

- A. General Conditions Article 4.7 – Shop Drawings and Other Submittals.
- B. Section 012901 – Measurement and Payment.
- C. Section 014300 - Quality Requirements.
- D. Section 016100 - Control of Materials.
- E. Section 017700 - Contract Closeout.
- F. Section 033000 – Cast-in-Place Concrete.
- G. Section 312300 - Excavation and Fill.
- H. Section 315000 – Excavation Support Systems.
- I. Section 331300 – Disinfecting of Water Utility Distribution.

1.04 REFERENCES

- A. American Society of Mechanical Engineers (ASME):
 1. B16.26: Cast Copper Alloy Fittings for Flared Copper Tubes
- B. ASTM International (ASTM):
 1. A36: Standard Specification for Carbon Structural Steel.

2. A252: Standard Specification for Welded and Seamless Steel Pipe Piles.
 3. A307: Standard Specification for Carbon Steel Bolts, Studs, and Threaded Rod 60,000 PSI Tensile Strength.
 4. B88: Standard Specification for Seamless Copper Water Tube.
 5. D449: Standard Specification for Asphalt Used in Damp-proofing and Waterproofing.
- C. American Welding Society (AWS):
1. D1.1: Structural Welding Code - Steel
- D. American Water Works Association (AWWA):
1. C104/A21.4: Cement-Mortar Lining for Ductile-Iron Pipe and Fittings.
 2. C110/A21.10: Ductile-Iron and Gray-Iron Fittings.
 3. C111/A21.11: Rubber-Gasket Joints for Ductile-Iron Pressure Pipe and Fittings.
 4. C115/A21.15: Flanged Ductile Iron Pipe with Ductile-Iron or Gray-Iron Threaded Flanges.
 5. C151/A21.51: Ductile-Iron Pipe, Centrifugally Cast.
 6. C208: Dimensions for Fabricated Steel Water Pipe Fittings.
 7. C500: Metal-Seated Gate Valves for Water Supply Service.
 8. C502: Dry-Barrel Fire Hydrants.
 9. C504: Rubber Seated Butterfly Valves.
 10. C509: Resilient-Seated Gate Valves for Water Supply Service.
 11. C550: Protective Interior Coatings for Valves and Hydrants.
 12. C600: Installation of Ductile-Iron Mains and Their Appurtenances.
 13. C800: Underground Service Line Valves and Fittings.
- E. Jersey City Municipal Utility Authority (JCMUA)
1. Rules and Regulations for Furnishing Water Service (Rules and Regulations), which can be found at <https://www.jcmua.com/rules-and-regulations>
 2. City of Jersey City Fire Hydrant Specification
- 1.05 DEFINITIONS
- A. Appurtenances: Additional piping items as required to provide a complete piping system suitable to convey water as specified and intended. These items may not be specified but are necessary to complete the piping system.
- B. JCMUA; Jersey City Municipal Utilities Authority, operates the water system within Jersey City.

1.06 SUBMITTALS

- A. Submit the following in accordance with General Conditions Article 4.7.
 - 1. Pipe materials.
 - 2. Pipe fittings.
 - 3. Pipe couplings.
 - 4. Thrust restraint.
 - 5. Valves.
 - 6. Fire hydrants.
 - 7. Linestop valves.
 - 8. Accessories.
 - 9. Casing, spacers and sealers.
 - 10. Appurtenances.
- B. Manufacturer's Certificate: Certify that products meet or exceed specified requirements.
- C. Instructions: Provide manufacturer's installation instructions for pipe, hydrants and valves.
- D. Provide line stop and temporary bypass construction details and sequence.
- E. Field Test Reports: Provide results for hydrostatic and bacteriological tests.
- F. Project Record Documents: Provide actual locations of piping mains, valves, connections, thrust restraints, line stop valves, and invert elevations. Identify and describe unexpected variations to subsoil conditions or discovery of uncharted utilities.

1.07 SPARE PARTS

- A. Comply with the requirements specified in Section 016100.

1.08 QUALITY ASSURANCE

- A. Comply with the requirements specified in Section 014300.
- B. Perform Work in accordance with the standards of the impacted water utility.
- C. Valves: Manufacturer's name, UL/FM and pressure rating marked on valve body.

1.09 DELIVERY STORAGE AND HANDLING

- A. Comply with the requirements specified in Section 016100.
- B. Deliver and store valves in shipping containers with labeling in place.

1.10 WARRANTY

- A. Provide standard product warranties for materials and as required by the impacted water utility.

PART 2 - PRODUCTS

2.01 MANUFACTURERS

- A. Ductile Iron Water Pipe: As required by impacted water utility or as manufactured by the following:
 - 1. American Cast Iron Pipe Co., Birmingham, AL;
 - 2. McWane Inc., Birmingham, AL;
 - 3. U.S. Pipe and Foundry Co., Birmingham, AL;
 - 4. Or approved equal.
- B. Flanged Adapters:
 - 1. McWane Inc., Birmingham, AL;
 - 2. Smith-Blair, Inc., Texarkana, AR;
 - 3. Or approved equal.
- C. Valves: As required by impacted water utility, or in Jersey City, JCMUA Rules and Regulations.
 - 1. Gate Valves. For mains and services greater than 2 inches:
 - a. American-Darling, Birmingham, AL;
 - b. Clow-McWane Valve Co.;
 - c. Mueller;
 - d. Or approved equal.
 - 2. Curb Valves (Curb Stops). For services between 3/4 and 2 inches inclusive:
 - a. Mueller;
 - b. Or approved equal.
- D. Fire Hydrants: As required by the impacted water utility as manufactured by the following:
 - 1. Mueller;
 - 2. Or approved equal.
- E. Line Stop Valves: As required by impacted water utility. Or as manufactured by the following:
 - 1. International Flow Technologies.
 - 2. Or approved equal.
- F. Accessories: As required by impacted water utility.

2.02 MATERIALS

- A. Water Pipe: For services 2-inch diameter or smaller, use seamless rolled soft copper water tube conforming to ASTM B88, Type K annealed. For 3-inch and larger

services, use cement mortar lined, corrosion protection coated ductile iron pipe with mechanical joints. Use Pressure Class 350 in Jersey City, and Thickness Class 54 in Weehawken and Hoboken. Install all pipe and tube, fittings, appurtenances, specials, necessary jointing materials, wall castings, wall sleeves, specials, adapters, and other appurtenances as shown on the Contract Drawings, as specified herein, and/or as necessary and required for a complete installation.

For mains and hydrant laterals, use ductile iron pipe as required by the impacted water utility and the following:

1. Ductile iron pipe, fittings, appurtenances, and specials shall be furnished and installed complete with all necessary jointing materials, wall castings, wall sleeves, specials, adapters, and other appurtenances as shown on the Contract Drawings, as specified herein, and/or as necessary and required for a complete installation.
 2. Use ductile iron pipe that conforms to AWWA C151 for push-on or mechanical joint pipe and AWWA C115 for flanged pipe. For temporary bypass piping, use flanged pipe. In Jersey City, use Pressure Class 350 ductile iron pipe. In Weehawken and Hoboken, use Thickness Class 54 ductile iron pipe. Pipe and fittings shall have mechanical joints conforming to AWWA C151. Use corrosion protection coated, cement mortar lined pipe conforming to ANSI/AWWA C104/A21.4.
 3. In Jersey City, use mechanical or push-on joints for straight runs, and mechanical joints for all bends.
- B. Fittings: For copper services, use cast bronze fittings for flared copper tubes conforming to ASME B16.26 and AWWA C800. Use flare fittings for copper connections. For mains and laterals, use ductile iron fittings, AWWA C110, match wall thickness of adjacent pipe. Ductile iron fittings shall have a cement-mortar lining and a seal coating meeting the requirements of ANSI/AWWA C104/A21.4. Use only standard, full size fittings. Compact fittings will not be permitted.
- C. Joints: AWWA C111, rubber gasketed for mechanical joints and AWWA C115 for flanged joints.
1. Mechanical joints shall be assembled in accordance with AWWA C600. Joints shall be restrained or harnessed to withstand test and surge pressure.
 2. Retainer glands with set screws shall be used on all mechanical joint connections. Mega lugs may be used instead of retainer glands; however, rodding, thrust blocks and concrete pads will still be required.
- D. Metal Seated Gate Valves – Solid Wedge and Double Disc Type.
1. General:
 - a. Use valves and sleeves that conform to AWWA C500 and as specified herein that have passed AWWA pressure testing by the manufacturer prior to installation. In Jersey City, use double disc valves.
 - b. Type of Joints: Mechanical joint.

- c. Stem: Non Rising-Stem (NRS), for sizes 4-in. through 48-in.
 - d. Gate valves 16-inch and larger shall be furnished with bypass.
 - e. Operator: 2-inch square operating nut, turn to the right to open
 - f. Design Working Pressures:
 - 1) Valves 12 Inches and Smaller: 200 psig.
 - 2) Valves 16 Inches and Larger: 150 psig.
 - g. In Hoboken, use resilient wedge gate valves for fire hydrant systems.
 - h. Tongue-and-groove guides shall be provided for solid-wedge valves.
 - i. Rollers and tracks shall be provided for horizontal 16-in. and larger double disc valves.
 - j. Double disc valves shall be provided with minimum four-point wedging mechanism.
 - k. Provide tapping sleeves and valves to make all taps.
 - l. For all taps 2 inches and larger, tapping valves shall be double disc gate valves. For taps less than 2 inches, the tapping valve may be a buried corporation valve.
 - m. For all taps 2 inches and larger, use solid ductile iron tapping sleeves such as Mueller H-615 or approved equal.
2. Materials of Construction: All materials of construction shall conform to the requirements of AWWA C500 and shall be as follows for various valve components:
- a. Body, Bonnet, Stuffing Box and Discs: Gray iron or ductile iron.
 - b. Seat and Disc Rings: Bronze, Composition A.
 - c. Stem and Stem Nut: Bronze, Composition C for valves up to 24 inches and Composition D for valves larger than 24 inches.
 - d. Disc Pin and Side Spreader: Bronze.
 - e. Top and Bottom Wedge Nuts: Cast iron with integrally cast bronze bushing.
 - f. Guide Contacts for 16-in. and Larger Valves: Bronze.
 - g. Rollers and Tracks: Bronze.
 - h. All internal and external bolting and other hardware including pins, set screws, studs, bolts, nuts and washers: Type 316 stainless steel.
 - i. All Rubber Items: Buna-N.
3. Interior Coating: All valves shall be coated inside, and holiday free in the waterway. The steel, cast-iron and ductile iron surfaces, except machined

surfaces, shall be 100 percent solid heat cured epoxy coated in accordance with AWWA C550.

4. Testing: All valves shall be shop tested in conformance with the requirement of AWWA C500.
- E. Insertion Valves: Use insertion valves with a 2-piece sleeve and a valve body and mechanism as specified for gate valves. Use non-rising stem valves that open right and have a 150 psi working pressure. Use insertion valves manufactured by the same manufacturer as specified for gate valves.
- F. Butterfly Valves: Butterfly valves shall conform to ANSI/AWWA C504, Class 150B, mechanical joint, with rubber seat mounted on the disc. Butterfly valves shall be furnished with a 2-inch square operating nut and shall operate by turning to the right. Valves shall be 100 percent solid heat cured epoxy coated, holiday-free in the waterway. Do not use butterfly valves in pipes smaller than 16-inch diameter.
- G. Fire Hydrants
1. In Jersey City, as required by City of Jersey City Fire Hydrant Specification (see attachment), including certification and warranty requirements: Mueller A423 Super Centurion 250 with integral 5-inch Storz pumper nozzle and two 2 3/8 inch hose nozzles GA 8-289, or approved equal.
 2. In Hoboken, Mueller A423 5 1/4-inch Super Centurion 250, 1997 Style, with pumper nozzle and two hose nozzles; 250 psi working pressure; 500 psi test pressure.
- H. Line Stop Valves and Equipment
1. Line stop valves shall be folding head type capable of temporarily plugging a pressurized cast iron pipe without disrupting pressure upstream of the valve. The folding head shall have a sealing element that uses an expandable folding cup to fit large diameter pipe that may be out of round. Line stop valves shall be rated for a pressure of at least 150 psi.
 2. Line stop fittings shall be carbon steel, fusion epoxy coated and lined.
 3. Drilling equipment shall be in good condition and equipped with power drive to ensure smooth cutting, and to minimize shock and vibration. Cutting equipment shall be carbide tipped and have a coupon retention device in the pilot hole suitable for retaining the size of the coupon to be cut.
- I. Corporation Stops: Standard corporation stop that conforms to AWWA C800.
- J. Curb Valve (Curb Stop): Standard curb valves that conforms to AWWA C800.
- K. Thrust Restraint:
1. For thrust blocks, use cast-in-place concrete as specified in Section 033000. Thrust block concrete to be Class B unless otherwise noted.
 2. Joint Assemblies: Joint assemblies shall be designed to resist pullout of the joints at the test pressures specified for the piping system.

- L. Tie Rods: Threaded steel rods that comply with ASTM A307 Grade 2, minimum size three quarter (3/4) inch diameter.
- M. Couplings: Use Dresser Style Number 153 sleeve type couplings for pipe sizes through 30 inch diameter. Sleeve type couplings shall be restrained with tie rods. For larger diameter pipe, use Dresser Style Number 38 couplings.
- N. For casing, use ASTM A252 steel pipe with 3/8-inch minimum wall thickness; galvanize according to ASTM A123. Fabricate fittings from the casing material according to AWWA C208 using butt welds. Size casing diameter according to AWWA C600. Use non-metallic or stainless steel casing spacers, as appropriate for the carrier pipe based on manufacturer recommendations and as approved by the Utility. For stainless steel spacers, use manufacturer-supplied runners, bands, risers, liners, studs and nuts. Ensure that runners are high-pressure molded glass reinforced polyester and bands are two-piece 14 gauge, Grade 304 stainless steel. Ensure that risers are 10 gauge, Grade 304 stainless steel and all nuts, studs, and washers are Grade 304 stainless steel. Ensure that liners are polyvinyl chloride. Ensure that spacers are 12-inch minimum width. At the ends of casings, install end seals. Use 1/8-inch minimum thickness synthetic rubber end seals with Grade 304 stainless steel banding straps and mastic strips to seal the edges, and rubber link modular seals with stainless steel hardware.
- O. Coarse Aggregate, Crushed Gravel, Broken Stone: Use coarse aggregate, No. 57 that complies with Section 312300.
- P. Backfill: Use virgin dense graded aggregate that complies with Section 312300. Dense graded aggregate shall not include recycled concrete aggregate or recycled asphalt pavement.
- Q. Bedding and Cover Materials: As specified in Section 312300 and the Contract Drawings, in Jersey City, in JCMUA Rules and Regulations.
- R. Disinfection Chemicals: Refer to Section 331300 and, in Jersey City, JCMUA Rules and Regulations.
- S. In corrosive environments, install polyethylene encased pipe, fittings and valves.
- T. Appurtenances: Provide appurtenances for a complete piping system suitable for operation, and in conformance with Contract Documents. For buried valves, provide the following appurtenances:
 - 1. Wrench Nuts:
 - a. Wrench nuts shall be provided on all buried valves and shall be of nominal 2-inch size conforming to AWWA C500.
 - b. Arrow indicating direction of opening the valve shall be cast on the nut along with the word “OPEN”.
 - c. Material: Ductile iron.
 - d. The nut shall be secured to the stem by mechanical means.
 - 2. T-Handle Operating Wrenches:

- a. Contractor to provide from valve manufacturer.
 - b. Provide T-Handle operating wrenches in lengths to permit operation of all valves by operators.
 - c. Provide one wrench for each permanent valve installed.
3. Extension Stems for Non-Rising Stem Gate Valves and Quarter Turn Buried Valves:
- a. Extension stems shall be provided to bring the operating nut to 6 inches below the box cover.
 - b. Minimum Size and Material: Same as valve stem.
 - c. Maximum Unsupported Length: 3 feet.
4. Valve Boxes:
- a. For services between 3/4 and 2 inches inclusive, curb boxes shall be Mueller or approved equal. For all other valves, valve boxes shall be Bingham and Taylor or approved equal. Use “Jersey City Standard” valve boxes in Jersey City.
 - b. Type: Heavy duty, suitable for highway loading, adjustable screw type, sized to fit valve with minimum diameter of 9 1/2 inches, extending from the surface to 3 inches above the valve bonnet base.
 - c. Material: Cast iron.
 - d. Coating: Two coats of asphalt coal tar epoxy waterproofing conforming to ASTM D449, Type I.
 - e. Marking: Use cast iron drop covers with “WATER” cast on the cover.

PART 3 - EXECUTION

3.01 EXAMINATION

- A. Verify existing conditions.
- B. Verify service connections and water main sizes, locations and inverts.

3.02 PREPARATION

- A. Provide the Construction Manager and the Utility with a detailed schedule of the work. Notify the Utility in writing at least 15 days before beginning construction of water facilities.
- B. Ream pipe and tube ends and remove burrs.
- C. Remove scale and dirt, on inside and outside, before assembly.
- D. Prepare pipe connections to equipment with flanges or unions.
- E. Excavate pipe trench in accordance with Section 312300. Hand trim as necessary.
- F. In Hoboken, Suez will coordinate shutdowns. Contact shd-utdw-hobokenconstruction@suez.com for shutdowns.

- G. In Weehawken, coordinate shutdowns with Suez.
- H. In Jersey City, JCMUA will operate valves. Notify JCMUA in writing 5 days in advance of valve operating requirements. The Contractor will not be allowed to operate valves.
- I. Elsewhere, do not operate valves unless under the direct supervision of the Utility.
- J. Perform the work in the presence of the Utility’s inspector.
- K. Support excavations in accordance with Section 314116 and Section 315000.

3.03 LINE STOP VALVE AND BYPASS PIPE INSTALLATION

- A. No work may begin on the line stop may begin until the Contractor’s proposed materials, layout plan and installation sequence are approved by the Architect/Engineer and JCMUA. Contractor shall allot sufficient time for submittal and review so as not to delay the work.
- B. Contractor shall not construct foundation section SW-08 and SW-09 until the line stop and bypass are installed. The bypass shall be routed such that these two foundation sections and the new water pipes can be installed with the bypass in place and operating. The foundations sections outside SW-08 and SW-09 can be constructed either before the bypass is installed or after the bypass is removed.
- C. Once SW-08 and SW-09 foundations are installed, the new permanent water pipes can be installed and the bypass removed.
- D. The following is an outline of the suggested line stop and temporary bypass pipe installation procedures. The Contractor is responsible for preparing and submitting detailed plans and procedures for approval and construction. Include sequence and procedure for Resist Structure construction in the detailed procedures for the line stopping and bypass.
- E. Clean the exterior of the water main to remove debris, corrosion deposits, or other surface irregularities that might interfere with the proper seating and sealing of line stop fittings against each main.
- F. Confirm the outside diameter of the existing pipes and caliper the diameter to determine ovality prior to ordering material.
- G. Bolt the line stop fittings to the main and place support blocking or concrete under fitting.
- H. Install thrust collars and tie rods from nearest pipe joint to the line stop valve as required to restrain thrusts.
- I. Mount temporary tapping valves to line stop fitting.
- J. Mount the tapping machine; open valve; pressure tap; retract cutter with coupon; close temporary valve; remove tapping machine.
- K. Install the line stop machinery, open temporary valve, and insert line stop plugging head into main.
- L. Install drain valve:

1. Install a 2-inch minimum drain tap to determine the amount of leakage through the line stop valve.
 2. Provide drainage pumps for dewatering as needed for the permanent work to be accomplished.
- M. Install temporary bypass pipe.
- N. After the permanent piping and the resist structure sheet piling and piles in the vicinity of the permanent piping are constructed, install the line stop machinery, open temporary valve and insert a line stop plugging head into the tee.
- O. Remove line stop equipment and temporary valves from water main and install blind flanges.
- P. Dispose of water and existing and temporary pipe at no additional cost to Owner.

3.04 WATER PIPE INSTALLATION

- A. Maintain uninterrupted, consistent service. The Utility may not allow work on their facilities from April 1 through September 30. All connections to existing shall be made with wet taps.
- B. Maintain separation of water main from sewer as follows:

1. Parallel Installation:

- a. Under normal conditions water mains shall be laid at least 10 feet horizontally from a sewer or sewer manhole. The distance shall be measured edge-to-edge.
- b. Under unusual conditions when local conditions prevent a horizontal separation of 10 feet, the water main may be laid closer to a sewer or sewer manhole provided that:
 - 1) The bottom (invert) of the water main is at least 18 inches above the top (crown) of the sewer;
 - 2) Where this vertical separation cannot be obtained, the sewer shall be constructed of AWWA approved water pipe, pressure tested in place without leakage prior to backfilling; and
 - 3) The sewer manhole shall be of watertight construction and tested in place.

2. Crossing

- a. Under normal conditions water lines crossing sewers shall be laid to provide a separation of at least 18 inches between the bottom of the water line and the top of the sewer whenever possible over a minimum distance of 10 feet on each side of the sewer.
- b. Under unusual conditions when local conditions prevent a vertical separation described, the following construction shall be used:

- 1) Sewers passing over or under water mains shall be constructed of AWWA approved water pipe, pressure tested in place without leakage prior to backfilling;
 - 2) Water lines passing under sewers shall, in addition, be protected by providing:
 - a) A vertical separation of at least 18 inches between the bottom of the sewer and the top of the water line;
 - b) Adequate structural support for the sewers to prevent excessive deflection of the joints and the settling on and breaking of the waterline; and
 - c) That the length of the water line be centered at the point of the crossing so that joints are equidistant and as far as possible from the sewer.
 - d) Provide concrete encasement and backfill as shown on the Contract Drawings.
 - 3) No water pipes shall pass through or come in contact with any part of a sewer manhole.
- C. For water pipe that crosses over an existing utility facility, use a casing pipe made of corrosion protected steel. When constructing water pipe under an existing water pipe, use concrete cradles or other support for the existing pipe.
- D. Where indicated on the drawings or directed by the Construction Manager, install solid or split casing; install split casing to protect existing water pipe to remain. Install spacers and end seals with casings. Use spacers that center and restrain the pipe in the casing. Locate and space spacers according to the manufacturer's recommendations, at a minimum: within one foot of each side of joints in the carrier pipe; intermediately at maximum 8-foot spacing; within one foot of each end of the casing; and an additional spacer 5 feet from each end of the casing. Cut casing for split casing to prevent warping in the fabrication shop. No field splitting will be allowed. Bevel welding surfaces. Weld joints in a minimum of two (2) passes. Weld the entire circumference and length of casing. Weld according to AWS D1.1. Construct casing to achieve a permanently leak-proof system. Repair galvanized coating according to ASTM A780.
- E. Use a laser system to control the alignment and grade of the pipe. Lay pipe in straight lines. If deviations from a straight line are approved by the Utility, ensure that the deflection at each pipe joint does not exceed the manufacturer's recommended maximum deflection.
- F. Ensure that the interior of the pipe is kept clean. Protect open ends of the pipe at all times and securely seal the openings with plugs approved by the Utility whenever work is stopped. Remove the plug and inspect and clean the interior of the pipe before resuming pipe installation.
- G. For mains, use the same pipe size as the existing pipe, with an 8-inch minimum.

- H. Install ductile iron piping and fittings in accordance with AWWA C600.
- I. Where the tap is equal to or larger than half the diameter of the main, use a tee instead of a tap.
- J. Install thrust blocks and tie rods at all bends and fittings.
- K. Install joint restraint per manufacturer's instructions. Submit instructions to Architect/Engineer for review. Restrain all fittings and valves using retainer glands or other means of thrust restraint such as snap lock or field lock gaskets.
- L. Form and place concrete for thrust blocks at each elbow or change of direction and at tees, plugs, and valves. Ensure thrust blocks are placed against firm, undisturbed ground. Ensure that thrust blocks do not come in contact with other utilities or structures.
- M. Provide additional pipe or connections necessary to bypass obstructions or other utilities. Adjust the depth of the pipe to pass obstructions, as approved by the Construction Manager.
- N. Cut pipe according to the manufacturer's recommendations. Ensure cuts are clean and square. Bevel pipe as necessary.
- O. Establish elevations of buried piping to ensure not less than 4 feet of cover in areas of vehicular traffic. In other areas, establish elevations of buried piping to ensure not less than 3 feet of cover. Do not exceed 6-foot bury depth. Excavate to 6 inches below the pipe barrel and coupling.
- P. Join pipe according to the manufacturer's recommendations and AWWA C600. Join pipe of dissimilar materials using factory-fabricated connection pieces installed in accordance with the manufacturer's recommendations.
- Q. Install air release valves at high points of water mains.
- R. Install trace wire buried 6 inches below finish grade continuous over top of pipe; coordinate with Section 312300. Extend wire into valve boxes and adjacent to hydrants for connection to locating equipment.
- S. Coordinate the installation of water mains with other work and prevent conflicts and interference with all existing facilities and proposed construction.
- T. Backfill trench in accordance with Section 312300 and the Contract Drawings.
- U. Cap or plug pipe that is to be abandoned in a manner that is acceptable to the Utility owner. Use plugs, fittings, rods and concrete as required as close to the existing water main in service as possible.
- V. Shut off and cap existing water service lines prior to the installation of new water services. Ensure that the Utility inspects and certifies the abandoned service.
- W. Remove facilities that are in direct conflict with the work.

3.05 VALVE AND HYDRANT INSTALLATION

- A. In City of Jersey City, install all valves, hydrants and appurtenances as required by JCMUA Rules and Regulations, AWWA C502, and in accord with the special hydrant provisions included herein:
1. Fire hydrants purchased or installed shall meet or exceed' all applicable requirements and tests of the latest revisions of ANSI/AWWA Standard C502. Fire hydrants shall meet all test requirements and be listed by Underwriters Laboratories Inc. Fire hydrants shall meet all test requirements and have full approval of Factory Mutual. In addition, fire hydrants shall meet the following requirements:
 2. Fire hydrants shall be rated for a working pressure of 250 Psig. (1725 kPa).
 3. Fire hydrants shall be of the compression type, opening against the pressure and closing with the pressure. They shall have a 5-1/4-inch main valve opening and a minimum inside lower/upper barrel diameter (I.D.) of 7” to assure maximum flow performance. Pressure loss at 1,000 GPM shall not exceed 2.50 psi through a 4.5-inch pumper nozzle.
 4. Fire hydrants shall be painted red with an aluminum colored bonnet. Hydrants shall be three-way in design, having one 5-inch Storz pumper nozzle and two 3/8-inch hose nozzles GA 8-289. The nozzles shall thread counterclockwise into hydrant barrel utilizing o-ring seals. A stainless steel nozzle lock shall be in place to prevent inadvertent nozzle removal. The 5-inch Storz pumper nozzle shall be integral to the hydrant and installed at the fire hydrant manufacturing facility, prior to hydrostatic testing. The Storz nozzle shall meet or exceed AWWA C502, NFPA-1963 and must be UL Certified and FM Approved for use on the fire hydrant. The hose nozzle caps shall have 1 1/4” pentagon shaped nuts.
 5. The bonnet assembly shall provide an oil reservoir and lubrication system that automatically circulates lubricant to all stem threads and bearing surfaces each time the hydrant is operated. This lubrication system shall be sealed from the waterway and any external contaminants by use of o-ring seals. An anti-friction washer shall be in place above the thrust collar to further minimize operating torque. The oil reservoir shall be factory filled with an FDA approved, non-toxic oil lubricant which will remain fluid through a temperature range of -60 degrees F. to +150 degrees F.
 6. The operating nut shall be a one piece design, manufactured of ASTM B-584 bronze. It shall have a 1 1/2-inch pentagon shaped nut. The hold down nut shall be threaded into the bonnet in such a manner as to prevent accidental disengagement during the opening cycle of the hydrant. The use of set screws as a means of retention is unacceptable.
 7. The opening direction shall be left. An arrow shall be cast on the bonnet flange to indicate the specified opening direction. The hydrant bonnet shall be attached to the upper barrel by not less than eight bolts and nuts and sealed by an o-ring.

8. Hydrants shall be a “traffic-model” having upper and lower barrels joined at the ground line by a separate and breakable “swivel” flange providing 360 degrees rotation of upper barrel for proper nozzle facing. This flange shall employ not less than eight bolts, and shall have no less than two grooves to ensure proper breakage. The safety flange segments shall be located under the upper barrel flange to prevent the segments from falling into the lower barrel when the hydrant is struck. The pressure seal between the barrels shall be an “o” ring. The proper ground line shall be cast clearly on the lower barrel and shall provide not less than 18 inches of clearance from the centerline of the lowest nozzle to the ground.
9. The operating stem shall consist of two pieces, not less than 1 1/4-inch diameter (excluding threaded or machined areas) and shall be connected by a stainless steel safety coupling. The safety coupling shall have an integral internal stop to prevent the coupling from sliding down into the lower barrel when the hydrant is struck. Screws, pins, bolts, or fasteners used in conjunction with the stem couplings shall also be stainless steel. The top of the lower stem shall be recessed 2-inch below the face of the safety flange to prevent water hammer in the event of a “drive over” where a vehicle tire might accidentally depress the main valve.
10. The lower barrel shall be an integrally cast unit. The use of threaded on or mechanically attached flanges is deemed unacceptable. The hydrant bury depth shall be clearly marked on the hydrant lower barrel.
11. Composition of the main valve shall be a molded rubber having a durometer hardness of 95 +/- 5 and shall be reversible in design so either side can be used. This will provide a spare in place. Plastic (polyurethane) main valves are unacceptable. The main valve shall have a cross section not less than 1-inch.
12. The upper valve plate, seat ring and drain ring must be bronze and work in conjunction to form an all bronze drain way. A minimum of two (2) internal and two (2) external drain openings are required. These drain openings shall work with (2) two drain valves which drain the barrel when the hydrant is closed and seal shut when the hydrant is opened. These drain valves shall be an integral part of the one piece bronze upper valve plate. They shall operate without the use of springs, toggles, tubes, levers or other intricate synchronizing mechanisms. Seat rings shall be o-ring pressure sealed, and shall have two (2) lugs, on top, which are sufficient for seat wrench engagement.
13. All brass components in contact with potable water must be made from either CDA/UNS Brass Alloys C89520 or C89833 with a maximum lead content of .25 percent by weight.
14. The hydrant shall have a 6”, ductile iron, mechanical joint shoe. A minimum of six bolts and nuts are required to fasten the shoe to the lower barrel.
15. The interior of the shoe including the lower valve plate and stem cap nut shall have a protective coating that meets the requirements of AWWA C-550. A

stem cap nut shall be utilized, and must be locked in place by a stainless steel lock washer or similar non-corrosive device that will prevent the cap nut from backing-off during normal use.

16. Hydrants shall be warranted by the manufacturer against defects in materials or workmanship for a period of ten years (10) from the date of manufacture. The manufacturing facility for the hydrant must have current ISO certification, and shall have been manufacturing and selling this model hydrant for at least five years.
 17. 16. Hydrants shall be made in the U.S.A. Furthermore, the hydrant's castings including the bonnet, upper barrel, lower barrel and shoe must be made in the U.S.A.
 18. Hydrants shall be the Mueller A-423 Super Centurion 250 with an integral 5-inch Storz pumper nozzle or pre-approved equal. Certification shall be provided confirming compliance to these specifications, including the use of low lead brass and domestic castings as referenced above. Certification shall come from a licensed professional engineer and/or an officer of the hydrant manufacturing company. The certification shall reference the City of Jersey City, the project and/or bid the hydrants are designated for, and the hydrant warranty.
 19. Failure to comply with any of these above requirements is sufficient cause for rejection of proposed hydrants. The City of Jersey City reserves the right to accept only those materials which are in full compliance with these specifications and deemed most advantageous to its interests.
- B. In Hoboken, install all valves, hydrants and appurtenances according to AWWA C502.
 - C. For each hydrant, install 6 inch ductile iron hydrant lateral, tee, 6 inch gate valve or valves depending on size of main, tie rods and hydrant. Provide additional pipe or connections necessary to bypass obstructions or utilities. Set the fire hydrant assembly plumb with the pumper nozzle normal to the face of the curb.
 - D. Place coarse aggregate around the base and install thrust blocks. Place 50-pound roofing felt as shown on the Contract Drawings. Do not interfere with drainage from the drip valve. Restrain hydrant assemblies from the hydrant back to the main.
 - E. Set valves on solid bearing, true to the pipe lines. Ensure that valve stems are set plumb. Support the valves with concrete blocking set on firm ground that has been compacted using a mechanical plate tamper.
 - F. Center and plumb valve box over valve. Set box cover flush with finished grade. Carefully tamp backfill to a lateral distance of 4 feet on all sides of the box, or to the undisturbed trench face if less than 4 feet.
 - G. In Jersey City, for all taps provide tapping sleeves and valves to JCMUA, who will make the wet tap. Coordinate as necessary with JCMUA to make the wet tap. The Contractor will not be permitted to make wet taps in Jersey City.

- H. In Jersey City, if the tap is into a water main that is 16 inches or larger, install a second gate valve with valve box immediately downstream from the tapping valve during installation of the pipe.
- I. In Jersey City, ensure that hydrants are no closer than 10 feet from the edge of a residential driveway and 20 feet from the edge of a commercial driveway.
- J. Elsewhere, install tapping sleeves and tapping valves in accordance with manufacturer's recommendations. Install tapping valves and insert valves as wet connections with no loss of water or interruption of flow. Notify the Utility 15 days before performing wet connections.
- K. Install valves and hydrants according to applicable AWWA Standards.
- L. Install all valves and appurtenances in accordance with manufacturer's instructions.

3.06 VALVE AND HYDRANT RESET

- A. Adjust the height of existing hydrants by adding to the vertical connection to the plug to meet the proposed grade.
- B. Do not move or disturb the location of the hydrant branch connection to the main.
- C. Adjust the height of existing water valve boxes so that each is set flush with the proposed grade without disturbing the existing valve.

3.07 ABANDONING VALVES AND HYDRANTS

- A. Excavate hydrant lateral and close valves before abandoning. Install mechanical joint plugs. Use plugs, fittings, rods and concrete as required as close to the existing water main in service as possible.
- B. In Hoboken, isolate valve and replace tapping sleeve or tee with spool piece unless otherwise directed.
- C. Remove existing valve stems and boxes that are being abandoned to a minimum depth of 2 feet below the finished grade.
- D. Remove existing hydrants that are being abandoned and deliver them to the municipality or water authority. Exercise care not to damage hydrants.
- E. Dispose of other materials.

3.08 DISINFECTION OF DOMESTIC WATER PIPING SYSTEM

- A. Before placing pipelines and 2 inch and larger services into service, disinfect the system as specified in Section 331300.

3.09 SERVICE CONNECTIONS

- A. Construct water service including valve, corporation stop, pipe, tube, sleeves, and curb stop to the existing water meter. Use the same pipe size as the existing service, with a ¾-inch minimum. All copper water services shall be installed with a "gooseneck" of the same size as the service. Form a loop of three feet of excess copper pipe at the gooseneck to the tap and laid to the right facing the tap. Use tapping sleeves and valves for all installations. Where the tap is equal to or larger

than half the diameter of the main, use a tee instead of a tap. Before performing water service connections, verify that the meter is operational. Notify the Utility and water service customers at least 7 days in advance of water shut-off. Install the temporary and permanent water services required to maintain consistent service. Install a continuous length of service pipe between the corporation stop and curb stop and between the curb stop and the foundation. Lay service pipe in a straight line from the water main to the property line or to within the building line at right angles to the street water main to which it is connected. Install water service pipe with at least 4 feet of cover. If subsurface conditions prohibit installing pipe with the required cover, shallower pipe and insulation may be used if approved by the water authority. Ductile iron water service pipe shall be continuously rodded, with thrust blocks at all bends and connections. Set the curb box to the proposed final grade. Close all valve and stop cocks on the inlet side of the water meter. Shut off existing services that are to be abandoned, install a plug in the existing curb stop, and remove the existing curb box.

3.10 REPAIR/RESTORATION

- A. Repair any existing utilities/structures or features damaged during installation of water utilities and restore the site to the previous condition to Construction Manager's satisfaction, and at no cost to the DEP.

3.11 FIELD TESTING

- A. Perform field-testing under provisions of Section 014300 before backfilling excavations.
- B. Hydrostatically test newly laid pipeline and valved sections thereof in accordance with AWWA C600. Pipelines shall be tested at a pressure of 1.5 times the working pressure or 150 psi, whichever is greater.
- C. Slowly fill each segregated section of pipeline with water ensuring that all air is expelled. Take extreme care to ensure that all air is expelled during the filling of pipe. The line shall stand full of water for at least twenty-four hours prior to testing to allow all air to escape. If necessary, tap the main at points of highest elevation to expel air as the pipe is filled. Remove the corporation stops and plug the taps after successfully filling the pipeline and expelling all air as approved by the Engineer.
- D. Apply the specified test pressure, measured at the point of lowest elevation, using a pump connected to the pipe in a manner satisfactory to the Engineer. If the elevation of the high point of the pipeline being tested is such that the pressure during testing will be below 85 percent of the required test pressure, the Engineer will require a separate test to be performed on this section of pipeline. In lieu of a separate test, the test pressure measured at the lowest elevation may be increased, within the pressure rating of the pipeline material, such that the resulting pressure at the highest point exceeds 85 percent of the required test pressure. The test will be conducted for at least two hours at the required test pressure plus or minus 5 psi.
- E. Conduct a leakage test concurrently with the pressure test. Leakage is defined as the volume of the water that must be supplied into the newly laid pipeline to maintain pressure within 5 psi of the test pressure after it is filled and purged of air. Measure

the volume of water using a calibrated container or meter. Make repairs or replace pipe as necessary to conform with these requirements.

3.12 INSPECTIONS

- A. Perform all water work in the presence of the Utility. In Jersey City, the water main construction shall be inspected by the Jersey City Municipal Utilities Authority and City Departments in accordance with JCMUA Rules and Regulations.

3.13 FIELD PAINTING/COATINGS

- A. Repair any shop painting/coatings damaged during storage or installation to the Construction Manager's satisfaction.
- B. All bolts, nuts, couplings and the like shall be coated after the joint has been made.
- C. Asphaltic Coating: Pipe and fittings that will not be exposed to view shall be coated with the standard asphaltic outside coating specified in AWWA C151, at twice the specified thickness.
- D. Pipe Couplings: Where flexible or rigid couplings are to be used, the exterior coating on the ends of pipe and fittings shall be left off for approximately 8-in., but the interiors shall be lined throughout.
- E. Painting of Buried Valves Exterior steel, cast-iron, and ductile iron surfaces except machined or bearing surfaces of all buried valves shall be shop-painted with two coats of asphalt waterproofing conforming to ASTM D449, Type I.

3.14 ADJUSTING

- A. Coordinate with Construction Manager for any field adjustments. The Construction Manager reserves the right to reject any field adjustments.

3.15 PROTECTION

- A. Protect installed water utilities from damage throughout storage, installation, testing, and final approval.

3.16 CLOSEOUT ACTIVITIES

- A. Provide in accordance with Section 017700.
- B. In Jersey City, provide record drawings in accordance with JCMUA Rules and Regulations. In Weehawken and Hoboken, provide similar record drawings.

END OF SECTION 331000

City of Jersey City Fire Hydrant Specification

Fire hydrants purchased or installed shall meet or exceed all applicable requirements and tests of the latest revisions of ANSI/AWWA Standard C502. Fire hydrants shall meet all test requirements and be listed by Underwriters Laboratories Inc. Fire hydrants shall meet all test requirements and have full approval of Factory Mutual. In addition, fire hydrants shall meet the following requirements

1. Fire hydrants shall be rated for a working pressure of 250 Psig. (1725 kPa).
2. Fire hydrants shall be of the compression type, opening against the pressure and closing with the pressure. **They shall have a 5-1/4" main valve opening** and a minimum inside lower/upper barrel diameter (I.D.) of 7" to assure maximum flow performance. Pressure loss at 1,000 GPM shall not exceed 2.50psi through a 4.5" pumper nozzle.
3. **Fire hydrants shall be painted red with an aluminum colored bonnet. Hydrants shall be three-way in design, having one 5" Storz pumper nozzle and two 2 3/8" hose nozzles GA 8-289.** The nozzles shall thread counterclockwise into hydrant barrel utilizing o-ring seals. A stainless steel nozzle lock shall be in place to prevent inadvertent nozzle removal. The 5" Storz pumper nozzle shall be integral to the hydrant and installed at the fire hydrant manufacturing facility, prior to hydrostatic testing. The Storz nozzle shall meet or exceed AWWA C502, NFPA-1963 and must be UL Certified and FM Approved for use on the fire hydrant. **The hose nozzle caps shall have 1 1/4" pentagon shaped nuts.**
4. The bonnet assembly shall provide an oil reservoir and lubrication system that automatically circulates lubricant to all stem threads and bearing surfaces each time the hydrant is operated. This lubrication system shall be sealed from the waterway and any external contaminants by use of o-ring seals. An anti-friction washer shall be in place above the thrust collar to further minimize operating torque. The oil reservoir shall be factory filled with an FDA approved, non-toxic oil lubricant which will remain fluid through a temperature range of -60° F. to +150° F.
5. The operating nut shall be a one piece design, manufactured of ASTM B-584 bronze. It shall have a 1 1/2" **pentagon shaped nut.** The hold down nut shall be threaded into the bonnet in such a manner as to prevent accidental disengagement during the opening cycle of the hydrant. The use of set screws as a means of retention is unacceptable.
6. **The opening direction shall be left.** An arrow shall be cast on the bonnet flange to indicate the specified opening direction. The hydrant bonnet shall be attached to the upper barrel by not less than eight bolts and nuts and sealed by an o-ring.
7. Hydrants shall be a "traffic-model" having upper and lower barrels joined at the ground line by a separate and breakable "swivel" flange providing 360° rotation of upper barrel for proper nozzle facing. This flange shall employ not less than eight bolts, and shall have no less than 2 grooves to ensure proper breakage. The safety flange segments shall be located under the upper barrel flange to prevent the segments from falling into the lower barrel when the hydrant is struck. The pressure seal between the barrels shall be an "o" ring. The proper ground line shall be cast clearly on the lower barrel and shall provide not less than 18" of clearance from the centerline of the lowest nozzle to the ground.
8. The operating stem shall consist of two pieces, not less than 1 1/4" diameter (excluding threaded or machined areas) and shall be connected by a stainless steel safety coupling. The safety coupling shall have an integral internal stop to prevent the coupling from sliding down into the lower barrel when the hydrant is struck. Screws, pins, bolts, or fasteners used in conjunction with the stem couplings shall also be stainless steel. The top of the lower stem shall be recessed 2" below the face of the safety flange to

prevent water hammer in the event of a “drive over” where a vehicle tire might accidentally depress the main valve.

9. The lower barrel shall be an integrally cast unit. The use of threaded on or mechanically attached flanges is deemed unacceptable. The hydrant bury depth shall be clearly marked on the hydrant lower barrel.

10. Composition of the main valve shall be a molded rubber having a durometer hardness of 95 +/- 5 and shall be reversible in design so either side can be used. This will provide a spare in place. Plastic (polyurethane) main valves are unacceptable. The main valve shall have a cross section not less than 1”.

11. The upper valve plate, seat ring and drain ring must be bronze and work in conjunction to form an all bronze drain way. A minimum of two (2) internal and two (2) external drain openings are required. These drain openings shall work with (2) two drain valves which drain the barrel when the hydrant is closed and seal shut when the hydrant is opened. These drain valves shall be an integral part of the one piece bronze upper valve plate. They shall operate without the use of springs, toggles, tubes, levers or other intricate synchronizing mechanisms. Seat rings shall be o-ring pressure sealed, and shall have two (2) lugs, on top, which are sufficient for seat wrench engagement.

12. All brass components in contact with potable water must be made from either CDA/UNS Brass Alloys C89520 or C89833 with a maximum lead content of .25% by weight.

13. **The hydrant shall have a 6”, ductile iron, mechanical joint shoe.** A minimum of six bolts and nuts are required to fasten the shoe to the lower barrel.

14. The interior of the shoe including the lower valve plate and stem cap nut shall have a protective coating that meets the requirements of AWWA C-550. A stem cap nut shall be utilized, and must be locked in place by a stainless steel lock washer or similar non-corrosive device that will prevent the cap nut from backing-off during normal use.

15. Hydrants shall be warranted by the manufacturer against defects in materials or workmanship for a period of ten years (10) from the date of manufacture. The manufacturing facility for the hydrant must have current ISO certification, and shall have been manufacturing and selling this model hydrant for at least five years.

16. Hydrants shall be made in the U.S.A. Furthermore, the hydrant’s castings including the bonnet, upper barrel, lower barrel and shoe must be made in the U.S.A.

17. **Hydrants shall be the Mueller A-423 Super Centurion 250 with an integral 5” Storz pumper nozzle** or pre-approved equal.

Certification shall be provided confirming compliance to these specifications, including the use of low lead brass and domestic castings as referenced above. Certification shall come from a licensed professional engineer and/or an officer of the hydrant manufacturing company. The certification shall reference the City of Jersey City, the project and/or bid the hydrants are designated for, and the hydrant warranty.

Failure to comply with any of these above requirements is sufficient cause for rejection of proposed hydrants. The City of Jersey City reserves the right to accept only those materials which are in full compliance with these specifications and deemed most advantageous to its interests.

SECTION 331300 - DISINFECTING OF WATER UTILITY DISTRIBUTION

PART 1 - GENERAL

1.01 DESCRIPTION

- A. Provide disinfecting of water utility distribution systems in compliance with Contract Documents.
- B. Section Includes:
 - 1. Disinfection of water mains in accordance with AWWA C651, except as modified herein.

1.02 PAYMENT

- A. No separate payment shall be made for performing any Work required under this Section. All costs for Work required by this Section shall be included in the applicable lump sum, unit price(s), or allowance(s) as set forth in Section 012901.

1.03 REFERENCES

- A. Code of Federal Regulations (CFR)
 - 1. 40 CFR Parts 141 through 143 – Federal Safe Drinking Water Act
- B. New Jersey Administrative Code (N.J.A.C.)
 - 1. New Jersey Safe Drinking Water Regulations (N.J.A.C. 7:10-1 *et seq.*)
- C. American Water Works Association (AWWA):
 - 1. C651: Disinfecting Water Mains.
 - 2. C652: Disinfection of Water-Storage Facilities.

1.04 RELATED SECTIONS

- A. General Conditions Article 4.7 – Shop Drawings and Other Submittals
- B. Section 012901 – Measurement and Payment
- C. Section 014300 – Quality Assurance
- D. Section 016100 – Control of Materials

E. Section 017700 – Contract Closeout

F. Section 331000 – Water Utilities

1.05 SEQUENCING

A. Basic procedure for disinfecting water mains:

1. Inspecting materials to be used to ensure their integrity.
2. Preventing contaminating materials from entering the water main during storage, construction, or repair, and noting potential contamination at the construction site.
3. Removing, by flushing or other means, those materials that may have entered the water main.
4. Chlorinating residual contamination that may remain, and flushing the chlorinated water from the main.
5. Protecting the existing distribution system from backflow caused by hydrostatic pressure test and disinfection procedures.
6. Documenting that an adequate level of chlorine contacted each pipe to provide disinfection.
7. Determining the bacteriological quality by laboratory test after disinfection.
8. Final connection of the accepted new water main to the active distribution system.

1.06 SUBMITTALS

A. Submit the following in accordance with General Conditions Article 4.7.

1. Supervisor qualifications.
2. Equipment list.

1.07 QUALITY ASSURANCE

A. Comply with the requirements specified in Section 014300.

B. Regulatory Requirements:

1. Disinfection work shall be acceptable to Jersey City Municipal Utilities Authority (JCMUA), or the impacted water utility, and the New Jersey health authority. If requirements of this section are in conflict with requirements of regulatory agencies, the latter shall govern.

- C. Source Quality Assurance:
 - 1. Perform Work in connection with disinfection under direction of experienced supervisor.
 - 2. Use equipment in proper working condition and adequate for specified Work.
- D. Prior to starting disinfection work, furnish detailed outline of proposed sequence of operation, manner of filling and flushing units, source and quality of water to be used, and disposal of wasted water.
- E. Perform work in connection with disinfection under direction of experienced supervisor.
- F. Use equipment in proper working condition and adequate for specified work.

1.08 DELIVERY STORAGE AND HANDLING

- A. Comply with the requirements specified in Section 016100.

1.09 PROJECT CONDITIONS

- A. Discharge of chlorinated water into watercourses or surface waters is regulated by the National Pollutant Discharge Elimination System (NPDES). Disposal of the chlorinated disinfection water and the flushing water is the Contractor's responsibility.
- B. Schedule the rate of flow and locations of discharges in advance to permit review and coordination with JCMUA, the impacted water utility, and cognizant regulatory authorities.

PART 2 - PRODUCTS

2.01 MATERIALS

- A. Water: Use potable water for cleaning and disinfection.
- B. Chlorine: Provide in accordance with AWWA C652.
 - 1. Calcium Hypochlorite (Dry): Dissolve in water to a known concentration in a drum and pump into the pipeline at a metered rate.
 - 2. Sodium Hypochlorite (Solution): Further dilute in water to desired concentration and pump into the pipeline at a metered rate.
 - 3. Commercial products such as "HTH", "Perchloron", and "Maxochlor" may be used in flake or crystal form, but in no instance will tablets be permitted to be used in the disinfection of water mains.

2.02 EQUIPMENT

- A. Submit list of equipment used for disinfecting work.

2.03 ACCESSORIES

- A. Chlorine Residual Test Kit: For measuring chlorine concentration, supply and use a medium range, drop count, N-diethyl-p-phenylene-diamine (DPD) drop dilution method kit per AWWA C651, Appendix A.1. Maintain kits in good working order available for immediate test of residuals at point of sampling.

PART 3 - EXECUTION

3.01 PREPARATION

- A. Isolate new work being disinfected from system to avoid possibility of contaminating materials entering the distribution system.
- B. Method of disinfection for water containment devices and piping systems shall conform to AWWA C651 and AWWA C652.

3.02 CHLORINE PREPARATION

- A. Calcium Hypochlorite:
 - 1. Prepare granular calcium hypochlorite as water mixture before introduction into unit. Make dry powder into paste and thin to approximately 1 percent chlorine solution.
 - 2. To prepare chlorine solution, add 1 pound of calcium hypochlorite (65 to 70 percent) available chlorine to 7-1/2 gallons of water.

3.03 PIPELINE PREPARATION

- A. After pressure and leakage tests are complete and the results are accepted, flush units thoroughly to remove foreign material.
- B. Release entrapped air at high points and fill units with disinfecting agent and water to allow disinfecting agent to come in contact with interior surfaces.
- C. If complete venting cannot be accomplished through available outlets, provide necessary corporation cocks and vent piping.

3.04 APPLICATION OF DISINFECTANT

- A. Point of Application:

1. Apply chlorinating agent at supply end of unit being disinfected.
2. For pipes, apply disinfectant through corporation cock installed in top of pipe.

B. Rate of Application:

1. Introduce water at controlled rate in order to regulate chlorine dosage.
2. Proportion rate of chlorine mixture flow to rate of water entering unit so chlorine dose applied shall initially produce 50 mg/L residual to the water and shall produce at least 25 mg/L chlorine residual after a period of 24 hours.
3. Use a method for determining rate of flow of water into the unit being disinfected that is acceptable to the Construction Manager.

C. Quality:

1. Retain chlorinated water in unit long enough to destroy non-spore forming bacteria.
2. Minimum retention period shall be 24 hours with chlorine residual at end of this period of not less than 25 mg/L (ppm).

D. Disinfecting Valves:

1. Operate valves and appurtenances while line or unit is being disinfected to ensure surfaces of valves are disinfected.

E. Swabbing:

1. Flush and swab pipe, fittings, and valves that must be placed in service immediately with 5 percent solution of calcium hypochlorite immediately prior to assembly.
2. Secure acceptance from the Construction Manager before using this method of disinfection.

F. Valve Operation: Performed by the impacted water utility.

3.05 DISINFECTING METHODS

A. Continuous Feed Method:

1. Introduce potable water into the pipeline at a constant measured rate. Feed the chlorine solution into the same water at a measured rate. Proportion the two rates so that the chlorine concentration in the pipeline is maintained at a minimum concentration of **25** mg/L. Check the concentration at points downstream during the filling to ascertain that sufficient chlorine is being added.

B. Disinfection of Valves, Blind Flanges, and Appurtenances:

1. During the period that the chlorine solution or slug is in the section of pipeline, open and close valves to obtain a chlorine residual at hydrants and other pipeline appurtenances. Swab exposed faces of valves and blind flanges prior to bolting flanges in place with a 1 percent sodium hypochlorite solution.

C. Disinfection of Connections to Existing Pipelines:

1. Disinfect isolation valves, pipe, and appurtenances in accordance with AWWA C651, Section 4.7. Flush with potable water until discolored water, mud, and debris are eliminated. Swab interior of pipe and fittings with a 1 percent sodium hypochlorite solution. After disinfection, flush with potable water again until water is free of chlorine odor.

D. Disinfection of Tapping Sleeves and Line Stopping:

1. Flush exterior of pipe with potable water after removal of existing coating. Swab exterior of pipe with a 1 percent sodium hypochlorite solution. Disinfect per AWWA C651, Section 4.8. After completion of tapping and line stopping, swab interior of pipe, valves, and faces of flanges to be connected to bypass piping with a 1 percent sodium hypochlorite solution.

E. Confirmation of Residual:

1. After the chlorine solution applied by the continuous feed method has been retained in the pipeline for 24 hours, confirm that a chlorine residual of 25 mg/L minimum exists along the pipeline by sampling at air valves and other points of access, such as tapping valves.

3.06 FINAL FLUSHING AND TEST

- A. Following chlorination, flush unit or system until replacement water in system is proven to be comparable in quality to water that will enter unit or system.
- B. Above acceptable condition of water delivered by each unit or system shall continue for at least 2 days, as demonstrated by laboratory examination of samples. Laboratory tests shall show chlorine residual, after final flushing, of less than 1 mg/L (ppm) or the residual of the water in the water system, whichever is greater.
- C. Repetition of Flushing and Testing: If initial treatment results in unsatisfactory bacterial test, repeat disinfection until satisfactory results are obtained.
- D. Prevent entry of contaminated water into previously disinfected units or systems.

3.07 BACTERIOLOGIC TESTS

- A. Collect two sets of samples per AWWA C651, Section 5.1, deliver to a certified laboratory within six hours of obtaining the samples, and obtain a bacteriologic quality test to demonstrate the absence of coliform organisms in each separate section of the pipeline after chlorination and refilling. Collect at least one set of samples from every new water main and line stopping insertion point. Take one set from the end of the line and at least one set from each branch. At each connection to an existing pipeline, take two additional samples.
- B. Ensure that the water conforms to the bacteriological standards specified in the New Jersey Safe Drinking Water Regulations (N.J.A.C. 7:10-1 et seq.) as well as the Federal Safe Drinking Water Act (40 CFR, Parts 141 through 143). Provide the test results to the impacted utility, and the Construction Manager.
- C. Repetition of Procedure: If the initial chlorination fails to produce required residuals and bacteriologic tests, repeat the chlorination and retesting until satisfactory results are obtained.
- D. Test Facility Removal: After satisfactory disinfection, disinfect and replace air valves, restore the pipe coating, and complete the pipeline where temporary disinfection or test facilities were installed.

3.08 FIELD QUALITY CONTROL

- A. Owner and Utility reserve the right to obtain samples and submit the samples to a laboratory for independent analysis. The Contractor shall repeat disinfection until satisfactory test results are obtained.
- B. If safe samples are not obtained using the above procedure, Contractor shall repeat disinfection until satisfactory test results are obtained.

3.09 CONTRACT CLOSEOUT

- A. Provide in accordance with Section 017700.

END OF SECTION 331300

NO TEXT ON THIS PAGE

SECTION 333000 - SANITARY SEWERAGE UTILITIES

PART 1 - GENERAL

1.01 SUMMARY

- A. This Section includes installing sanitary sewer and combined sewer gravity mains, sanitary sewer and combined sewer manholes, sanitary sewer connections, miscellaneous fittings, and testing.

1.02 PAYMENT

- A. No separate payment shall be made for performing any Work required under this Section. All costs for Work required by this Section shall be included in the applicable lump sum(s), unit price(s), or allowance(s) as set forth in Section 012901.

1.03 RELATED SECTIONS

- A. General Conditions Article 4.7 – Shop Drawings and Other Submittals
- B. Section 012901 – Measurement and Payment.
- C. Section 014300 - Quality Requirements.
- D. Section 016100 - Control of Materials
- E. Section 017700 - Contract Closeout
- F. Section 033000 - Cast-in-place Concrete
- G. Section 312300 - Excavation and Fill
- H. Section 331000 - Water Utilities
- I. Section 333915 - Manholes and Structures.

1.04 REFERENCES

- A. American Welding Society (AWS):
 - 1. D1.1: Structural Steel Welding Code- Steel.
- B. ASTM International (ASTM):
 - 1. A48: Standard Specification for Gray Iron Castings

2. A53: Pipe, Steel, Black and Hot-Dipped, Zinc-Coated, Welded and Seamless.
3. A74: Standard Specification for Cast Iron Soil Pipe and Fittings.
4. A139: Pipe, Steel, Black and Hot-Dipped, Zinc-Coated, Welded and Seamless.
5. C14: Standard Specification for Concrete Sewer, Storm Drain, and Culvert Pipe.
6. C76: Standard Specification for Reinforced Concrete Culvert, Storm Drain, and Sewer Pipe.
9. C443: Standard Specification for Joints for Concrete Pipe and Manholes, Using Rubber Gaskets.
10. C923: Standard Specification for Resilient Connectors Between Reinforced Concrete Manhole Structures, Pipes and Laterals.
11. C1244: Standard Test Method for Concrete Sewer Manholes by the Negative Air Pressure (Vacuum) Test Prior to Backfill.
13. D1784: Standard Classification System and Basis for Specification for Rigid Poly (Vinyl Chloride) (PVC) Compounds and Chlorinated Poly (Vinyl Chloride) CPVC Compounds
14. D1785: Standard Specification for Poly (Vinyl Chloride) (PVC) Plastic Pipe, Schedules 40, 80, and 120.
15. D2241: Poly (Vinyl Chloride) (PVC) Pressure-Rated Pipe (SDR Series).
16. D2321: Standard Practice for Underground Installation of Thermoplastic Pipe for Sewers and Other Gravity-Flow Applications.
17. D2680:D2729: Standard Specification for Poly (Vinyl Chloride) (PVC) Sewer Pipe and Fittings.
19. D2751: Standard Specification for Acrylonitrile-Butadiene-Styrene (ABS) Sewer Pipe and Fittings.
20. D3034: Standard Specification for Type PSM Poly (Vinyl Chloride) (PVC) Sewer Pipe and Fittings.
21. D3139: Standard Specification for Joints for Plastic Pressure Pipes using Flexible Elastomeric Seals.
22. D3212: Standard Specification for Joints for Drain and Sewer Plastic Pipes Using Flexible Elastomeric Seals.

23. F477: Elastomeric Seals (Gaskets) for Joining Plastic Pipe.
24. F679: Standard Specification for Poly (Vinyl Chloride) (PVC) Large-Diameter Plastic Gravity Sewer Pipe and Fittings.

C. American Water Works Association (AWWA):

1. C104/A21.4: Cement-Mortar Lining for Ductile-Iron Pipe and Fittings for Water.
2. C110/A21.10: Ductile Iron and Gray Iron Fittings, 3 Inch Through 48 Inch for Water and Other Liquids.
3. C111/A21.11: Rubber-Gasket Joints for Ductile-Iron Pressure Pipe and Fittings.
4. C150/A21.50: Thickness Design of Ductile Iron Pipe.
5. C151/A21.51: Ductile-Iron Pipe, Centrifugally Cast, for Water.
6. C153/A21.53: Ductile Iron Compact Fittings, 3 inch through 24 Inch and 54 Inch Through 64 Inch for Water Service.
7. C600: Installation of Ductile-Iron Water Mains and Their Appurtenances.
8. C605: Underground Installation of PVC Pressure Pipe and Fittings for Water.
9. C901: Polyethylene (PE) Pressure Pipe and Tubing, 1/2 In. (13 mm) Through 3 In. (76 mm), for Water Service.

D. UNI-BELL (UNI):

1. B-6: Recommended Practice for Low-Pressure Air Testing of Installed Sewer Pipe.

E. Jersey City Municipal Utilities Authority:

1. Rules and Regulations Governing the Operation of the Jersey City Sewer System.
2. Standard Requirements for New Sanitary and Storm Sewers and Service Laterals.

1.05 DEFINITIONS

- A. Appurtenances: Additional piping items to provide a complete piping system suitable to convey wastewater as specified and intended. These items may or may not be specified but are necessary to complete the piping system.
- B. JCMUA – Jersey City Municipal Utility Authority, agency responsible for the sanitary sewer system in Jersey City.

- C. Standard Specifications: The following Standard Specifications shall apply for materials and methods not specified in this Section:
 - 1. For work within the limits of the Jersey City Municipal Utility Authority (JCMUA) service area, “Rules and Regulations Governing the Operation of the Jersey City Sewer System”.
 - 2. For all other areas, provisions for water and sanitary sewer utility construction in the “NJDOT Standard Specifications for Road and Bridge Construction”.

1.06 SUBMITTALS

- A. Submit the following in accordance with General Conditions Article 4.7.
 - 1. Pipe materials.
 - 2. Pipe fittings.
 - 3. Pipe couplings.
 - 4. Accessories.
 - 5. Appurtenances.
- B. Manufacturer's Certificate: Certify that products meet or exceed specified requirements.
- C. Instructions: Provide manufacturer's installation instructions for pipes.
- D. Field Test Reports: Provide results for all testing performed as indicated in Paragraph 3.07 Field Testing.
- E. Project Record Documents: Submit CADD files showing as built locations of piping, connections and invert elevations as indicated in Paragraph 3.10 As Built. Identify and describe unexpected variations to subsoil conditions or discovery of uncharted utilities.

1.07 SPARE PARTS

- A. Comply with the requirements specified in Section 016100.

1.08 QUALITY ASSURANCE

- A. Comply with the requirements specified in Section 014300.
- B. Perform Work in accordance with NJDOT Standard Specifications for Road and Bridge and Road Construction and/or JCMUA “Rules and Regulations Governing the Operation of the Jersey City Sewer System”, as applicable.

1.09 DELIVERY STORAGE AND HANDLING

- A. Comply with the requirements specified in Section 016100.

1.10 WARRANTY

- A. Provide standard product warranties for all sanitary sewerage utility materials.

PART 2 - PRODUCTS

2.01 MANUFACTURERS

- A. Mechanical Joint Restraint:
 - 1. EBBA Iron Megalug.
 - 2. Ford Meter Company, Inc.
 - 3. U.S. Pipe and Foundry (a Forterra Company)
 - 4. Or approved equal.

2.02 GRAVITY SANITARY SEWER PIPE

- A. Ductile Iron Pipe: ANSI/AWWA C151/A21.51 with standard thickness cement-mortar lining conforming to ANSI/AWWA C104/A21.4 with interior and exterior asphaltic coating, furnished in 18 or 20-foot lengths. Pipe thickness conforming to ANSI/AWWA C150/A21.50, based on maximum anticipated earth loading with H-20 vehicle load, minimum bedding condition 2, Thickness Class 52 minimum. Joints: ANSI/AWWA C111/A21.11, push-on restrained joint type with rubber gasket; TR Flex by U.S. Pipe, American Cast Iron Pipe Co., McWane Ductile Pipe Co., or approved equal.
- B. Reinforced Concrete Pipe: ASTM C76, Class III, in 8-foot lengths with circumferential reinforcement. Joint Device: ASTM C443, rubber compression gasket joint.
- C. Polyvinyl Chloride (PVC) Pipe: ASTM D3034, SDR 35, Poly (vinyl chloride) (PVC) material; for pipe through 15-inch diameter, and ASTM F679 for diameters larger than 15 inches., integral bell elastomeric gasketed joint.

2.03 PRECAST CONCRETE MANHOLES

- A. Refer to Section 333915 for additional requirements.
- B. Provide precast base sections that extend above pipe top and form portion of barrel. Barrel sections constructed of manhole risers topped with tapered sections or flat tops as

indicated. Conform manhole sections to ASTM C478; resilient connectors to ASTM C923.

- C. Joints: O-Ring rubber-gasket joints conforming to ASTM C443, confined as indicated.
- D. Pipe Connections: Pipe connections, if necessary, shall be made in conformance with the requirement of the North Hudson Sewerage Authority.
- E. Precast Inverts: Conform to invert channels specified in Part 3 of this Section.
- F. Mortar and Grout: Conform to applicable NJDOT Standard Specification form Bridge and Road Construction.

2.04 MANHOLE FRAME AND COVERS

- A. Refer to Section 333915 for additional requirements.
- B. Provide cast-iron frames and covers as required by the structure and ASTM A48, Class 30S, in conformance with North Hudson Sewerage Authority standards.
- C. Provide frames and covers suitable for AASHTO HS 20-44 live load. Combined weight of 355 pounds minimum, 225-pound minimum frame, and 130-pound minimum cover weight.
- D. Provide factory-coated with asphalt varnish.
- E. Provide frames with 24-inch nominal diameter clear openings.
- F. Provide removable, interchangeable covers to seat in frames without rocking.
- G. Identify covers with cast marking as directed by Architect/Engineer “SANITARY SEWER” and include the name and location of manufacturer on frame and cover castings.
- H. Provide castings free of blowholes, splits, cracks, blisters, and other imperfections affecting strength or serviceability.
- I. Provide External or Internal Seals as required by Architect/Engineer in accordance with the Contract Drawings.

2.05 CLEANOUTS

- A. Refer to Section 333915.

2.06 DRYWELLS

- A. Refer to Section 333915.

2.07 BEDDING AND OTHER MATERIALS

- A. As specified in Section 312300.

2.08 THRUST RESTRAINT

- A. Mechanical Joint Restraint: Wedge action restrained joint retainer gland devices. Mechanical joint restraint incorporated into the design of the follower gland.
- B. Thrust Blocks: Dimensions as indicated. Concrete type for thrust restraints as specified in Section 033000.
- C. Pipe Clamps and Tie Rods: ANSI/NFPA 24.
- D. Push-On Restrained Joint Pipe: Provide joint restraint and conforming joint to AWWA C111/21.11, fabricated to be easily disassembled. Provide assembly and disassembly kits.

2.09 ACCESSORIES

- A. Flexible Couplings: Sleeve type elastomeric polyvinyl chloride held firmly to pipe ends by screw-tightened bands. Bands and screws Type 304 stainless steel.

2.10 APPURTENANCES

- A. Provide all necessary appurtenances for a full and complete piping system suitable for operation, and in conformance with Contract Documents.

2.11 SHOP PAINTING/COATINGS

- A. Unless otherwise specified or indicated, provide standard manufacturer paint and coatings for all piping and valves to prevent corrosion for the life of the component. Comply with JCMUA or North Hudson Sewer Authority (NHSA) standards, as applicable.

2.12 SHOP TESTING

- A. Test all pipes and valves per manufacturer requirements, and as required by pertinent Standards.

PART 3 - EXECUTION

3.01 EXAMINATION

- A. Verify that excavation base is ready to receive Work and excavations, dimensions, and elevations are as indicated for sanitary sewer pipe. Verify excavation for manholes to proper depth and proper placement of bedding material.

3.02 PREPARATION

- A. Sanitary sewer pipe: Hand trim excavations to required elevations. Correct over excavation with bedding material. Remove large stones or other hard matter which could damage pipe or impede consistent backfilling or compaction.
- B. Manholes: Coordinate placement of inlet and outlet pipe sleeves. Seal exterior surface of sanitary sewer manholes with minimum 14-mil-thick coal tar coating.

3.03 SANITARY SEWER PIPE INSTALLATION

- A. Maintain separation of sanitary sewers pipe and water mains as indicated in Contract Section 331000.
- B. Install pipe, fittings, and accessories in accordance with ASTM C12 and manufacturer's instructions. Seal joints watertight.
- C. Lay pipe to slope indicated; with maximum variation from true slope of 1/8-inch in 10 feet. Lay pipe upgrade, with spigot ends pointing in direction of flow. Lay pipe to form a close concentric joint with adjoining section and to prevent sudden offsets in flow line.
- D. Install bedding to depths and dimensions as indicated on plans or as directed by the Construction Manager.
- E. Backfill each section of pipe as it is laid, as specified in Section 312300 and as indicated at least up to centerline, before next joint is made. Do not completely conceal or bury pipe prior to being tested for water tightness and prior to being accepted by the Construction Manager. Do not displace or damage pipe when compacting.
- F. Clear the interior of the pipe of dirt and superfluous materials as the work progresses. Keep a suitable swab or drag in the pipe and pull it forward past each joint immediately after the jointing has been completed.
- G. Keep trenches and other excavations free of water until final inspection. Do not lay pipe or construct masonry work in water. Do not allow water to rise over the work until concrete or mortar has had ample time to set.
- H. Close open ends of pipe and fittings in a manner acceptable to the Construction Manager when the Work is not in progress so that trench water, earth, and other substances will not enter the pipe or fittings.
- I. Handle pipe and fittings to avoid damage. Carefully inspect pipe and fittings for defects before lowering into the trench.

- J. Where necessary deflect pipelines to avoid obstructions or where long-radius curves are indicated. Do not exceed the maximum deflection recommended by pipe manufacturer. Provide short sections of pipe as necessary to maintain required line.
- K. Provide compatible pipe connections. Connect different types of pipe and accessories with flexible couplings or pipe and accessories with flexible couplings or accepted transition fittings. Provide insulation fittings where ferrous pipe connects to nonferrous metallic pipe, as necessary.
- L. Verify invert of each existing manhole prior to commencing work. Connect to each existing manhole where indicated or directed. Prevent debris from entering the pipelines. The work includes all necessary concrete work, cutting and shaping of invert.
- M. Make taps into existing manholes by coring. Install a flexible pipe-to-manhole connector after coring.
- N. Repair linings, coatings and coverings damaged during construction with accepted materials equal to and compatible with original lining, coating or covering. Repair damaged galvanizing with zinc-rich paint.
- O. Make connections to existing systems as indicated.
- P. Placement of pipe sleeves in concrete retaining walls is specified in Section 033000.
- Q. Construction of New Manholes Over Existing Sanitary Pipelines: Expose existing pipeline and field-verify its location and invert. Install bulkhead or other flow diversion method and perform by-pass pumping, as necessary. Construct each manhole using precast manhole sections, unless otherwise authorized in writing by the Construction Manager. Provide connection between existing pipe and new manhole as shown on the Contract Drawings.

3.04 PRECAST CONCRETE MANHOLE INSTALLATION

- A. Refer to Section 333915 for additional requirements.
- B. Maintain separation of sanitary sewer precast concrete manholes and water mains as indicated in Section 331000.
- C. Place precast manhole sections plumb and level, adjust to correct elevation. Provide bedding material as indicated.
- D. After manhole assembly, plug lift-holes with non-shrink grout.
- E. Cut and fit for pipe connections.
- F. Invert Channels:

1. Built up with concrete, grout, or brick and mortar covered by not less than 2 inches of mortar.
2. Smooth and semicircular, conforming to inside of adjacent sewer section.
3. Changes in direction of flow made with a smooth curve radius as large as manhole size will permit.
4. Slope floor of manhole outside channels, smooth and not less than 1 inch per foot nor more than 2 inches per foot.
5. Place channels so as not to interfere with the flexibility of pipe-to-manhole joints.

G. Set manhole frames and covers level to correct elevations.

3.05 CLEANOUTS

A. Refer to Section 333915.

3.06 DRYWELL

A. Refer to Section 333915.

3.07 REPAIR/RESTORATION

A. Repair any existing utilities/structures, or features damaged during installation of sanitary sewerage utilities to Construction Manager's satisfaction, and at no cost to the DEP.

3.08 FIELD TESTING

A. General:

1. All existing sewer mains and sanitary laterals to be abandoned must be filled with concrete slurry or removed from the ground. Catch basins and manholes must be removed from the ground. Connections must be cut and sealed at the main and precautions must be undertaken by the Contractor to ensure concrete and other materials do not enter the main and create obstruction(s).
2. Perform field-testing under provisions of Section 014300.
3. Request inspection by Construction Manager prior to and immediately after placing bedding.

B. Cleaning and Testing

1. Test for Displacement of Buried Sanitary Sewers: After trench has been backfilled and compacted, after cover over pipeline has been brought to finished grade, and

after debris and silt has been removed, pipelines will be tested by the Construction Manager, as follows: Light will be flashed between manholes, or, if manholes have not yet been constructed, between locations of manholes, by means of flashlight or by reflecting sunlight with mirror. Correct poor alignment, displaced pipe, and other defects indicated by the Construction Manager.

2. Test for Deflection of PVC Sanitary Sewers
 - a. Measure pipelines for vertical ring deflection within 15 days after completion of backfill and at least 4 months after installation, but no later than 30 days before substantial completion of the project. Limit maximum ring deflection of pipeline under load to 5 percent of vertical internal pipe diameter. Relay or replace pipe exceeding this deflection and retest.
 - b. Use deflectometer that produces continuous record of pipe deflection or pull mandrel, sphere, or pin-type go/no-go device through the pipeline. Make diameter of the go/no-go device 95 percent of undeflected inside diameter of pipe.
3. Cleaning: Flush out and clean sanitary force mains of foreign matter before placing systems into operation. Use flushing velocity of 10 feet per second, minimum. Take care to prevent scale and other objectionable matter from entering piping. Properly dispose of water used for flushing.
4. Testing of Sanitary Sewers: At such times as Construction Manager may direct, prove watertightness of buried sanitary sewer or portions thereof by one of the following tests. Conduct tests under supervision of the Construction Manager. Furnish materials, labor, and equipment required for tests and repair system until test results are satisfactory.
5. Infiltration: When, in opinion of the Construction Manager, trench or excavation is sufficiently saturated by groundwater or rain, tests may be made on basis of infiltration. Infiltration tests will only be allowed when hydrostatic head outside pipe is minimum of 4 feet above crown of pipe for entire length of pipe being tested. Measure flow of water at nearest downgrade manhole. Make three series of measurements at intervals of not less than 1 hour, and average results. Using this average, calculate infiltration rate for 24-hour period. Infiltration rate: Not greater than 100 gallons per inch of pipe diameter per mile per day in any section of system including manholes.
6. Exfiltration: When conditions are not suitable for infiltration test, subject pipe to hydrostatic head of at least 4 feet above pipe crown. Fill line until appropriate water level is obtained at selected upstream manhole. Observe rate of drop at this manhole for 1 hour. Leakage rate: Not to exceed maximum rate allowed for infiltration.

7. Air Test: At Contractor’s option, low-pressure air test may be used instead of exfiltration test for PVC and concrete pipelines 12 inches and smaller. Perform tests in accordance with UNI B6 for PVC pipelines, and ASTM C924/924M for concrete and ductile iron pipelines.
8. Vacuum test: For precast concrete manholes 25 feet (7.5 m) deep and less, a vacuum test may be used instead of exfiltration test. Conduct tests prior to backfilling and include joint between manhole cover and frame. Plug and brace pipe openings. Draw vacuum of 10 inches of mercury (34 kPa). Minimum time to drop to 9 inches of mercury (30 kPa) follows:

Table 333000-1			
	Manhole Diameter in Inches		
Depth in Feet	48	60	72
Up to 10	60 sec.	75 sec.	90 sec.
10.01-15	75 sec.	90 sec.	105 sec.
15.01-25	90 sec.	105 sec.	120 sec.

9. If manhole fails the test, make necessary repairs and repeat the vacuum test and repairs until manhole passes test. Submit test results.

3.09 FIELD PAINTING/COATINGS

- A. Repair any shop painting/coatings damaged during storage or installation to Construction Manager’s satisfaction.

3.10 ADJUSTING

- A. Coordinate with Construction Manager for field adjustments. The Construction Manager reserve the right to reject field adjustments.

3.11 PROTECTION

- A. Protect sanitary sewerage utilities from damage throughout storage, installation, testing, and final acceptance.

3.12 AS-BUILT

- A. Within five (5) days of completion of each pipe run, submit as-built plans and an AutoCad file to the Construction Manager and the Utility. Ensure that as-builts are signed and sealed by a New Jersey Licensed Professional Engineer or Land Surveyor. In Jersey City, ensure that as-builts meet all requirements of JCMUA’s Submission of Record Drawings for Extension of Water/Sewer Mains and Other Water/Wastewater Facilities. Include as-built locations of piping, connections, lateral locations, invert elevations, depth of cover, and manhole locations and rim and invert elevations. For connections, include depth at

clean out, length of lateral from cleanout to main, stationing, upstream and downstream manhole data and location by triangulation of all cleanouts, tees and wyes. Identify and describe unexpected variations in subsoil conditions or discovery of uncharted utility facilities.

3.13 CONTRACT CLOSEOUT

- A. Provide in accordance with Section 017700.

END OF SECTION 333000

NO TEXT ON THIS PAGE

SECTION 333915 - MANHOLES AND STRUCTURES

PART 1 - GENERAL

1.01 DESCRIPTION

- A. Provide manholes and structures as indicated and in compliance with Contract Documents.

1.02 PAYMENT

- A. No separate payment shall be made for performing any Work required under this Section. All costs for Work required by this Section shall be included in the applicable lump sum(s), unit price(s), or allowance(s) as set forth in Section 012901.

1.03 REFERENCES

- A. American Concrete Institute (ACI):

1. 318: Building Code Requirements for Structural Concrete.
2. 530: Building Code Requirements and Specifications for Masonry Structures.

- B. American Welding Society (AWS):

1. D1.1: Structural Steel Welding Code- Steel.

- C. ASTM International (ASTM):

1. A48/A48M: Standard Specification for Gray Iron Castings.
2. A123/A123M: Standard Specification for Zinc (Hot-Dip Galvanized) Coatings on Iron and Steel Products.
3. A536: Standard Specification for Ductile Iron Castings.
4. A615/A615M: Standard Specification for Deformed and Plain Carbon-Steel Bars for Concrete Reinforcement.
5. C139: Standard Specification for Concrete Masonry Units for Construction of Catch Basins and Manholes.
6. C140: Standard Test Methods for Sampling and Testing Concrete Masonry Units and Related Units.

7. C478/C478M: Standard Specification for Circular Precast Reinforced Concrete Manhole Sections.
8. C881: Standard Specification for Epoxy-Resin-Base Bonding Systems for Concrete.
9. C913: Standard Specification for Precast Concrete Water and Wastewater Structures.
10. C923: Standard Specification for Resilient Connectors Between Reinforced Concrete Manhole Structures, Pipes, and Laterals.
11. D41: Standard Specification for Asphalt Primer Used in Roofing, Dampproofing, and Waterproofing.
12. D449: Standard Specification for Asphalt Used in Dampproofing and Waterproofing.
13. D4101: Standard Classification System and Basis for Specification for Polypropylene Injection and Extrusion Materials.

D. Code of Federal Regulations (CFR):

1. 29 CFR 1926: Safety and Health Regulations for Construction.

1.04 RELATED SECTIONS

- A. General Conditions Article 4.7 – Shop Drawings and Other Submittals.
- B. Section 012901 - Measurement and Payment.
- C. Section 014300 - Quality Requirements.
- D. Section 016100 - Control of Materials.
- E. Section 017700 - Contract Closeout.
- F. Section 031000 - Concrete Formwork.
- G. Section 032100 - Reinforcement Bars.
- H. Section 033000 - Cast-in-Place Concrete.
- I. Section 033400 – Controlled Low Strength Material (CLSM)
- J. Section 312300 - Excavation and Fill.

K. Requirements from the following sections also apply to this Section:

1. Section 333000 – Sanitary Sewerage Utilities
2. Section 334000 – Storm Drainage Utilities

1.05 DESIGN REQUIREMENTS

- A. Structural Design: In accordance with ACI 318.
- B. Masonry Design: In accordance with ACI 530.
- C. Design of Lifting Devices for Precast Components: In accordance with ASTM C913.
- D. Design of Joints for Precast Components: In accordance with ASTM C913; provide watertight structures.
- E. Ensure that castings, grates, extension rings, extension frames, and covers for inlets and manholes are capable of withstanding HS-25 loading when tested as a complete, assembled unit.
- F. Design and install manhole and structure to withstand hydrostatic uplift caused by a groundwater elevation at grade level or equal to the top of the manhole and structure, which ever produces the most severe condition. Use only the weight of the manhole and structure and hold-down slab to resist hydrostatic uplift with a minimum safety factor of 1.15. Do not include side friction of soils on walls.

1.06 SUBMITTALS

- A. Submit the following shop drawings in accordance with General Conditions Article 4.7.
 1. Shop Drawings: Indicate manhole and structure locations, elevations, reinforcement, dimensions, appurtenances, pipe/conduit sizes and elevations of penetrations.
 2. Product Data: Submit cover and frame construction, features, configuration, dimensions, and type.
 3. One copy of results of tests and certification reports with each shipment of materials.
 4. Reinforcement Steel: Certificate of compliance with specifications.
 5. Concrete: Certificate of compliance with specifications.
 6. Aggregates: Certificate of compliance with specifications.

7. CLSM: Certificate of compliance with specifications.

1.07 QUALITY ASSURANCE

- A. Comply with the requirements specified in Section 014300.
- B. Perform work in accordance with Municipalities (City of Hoboken, City of Jersey City, and Township of Weehawken) and/or North Hudson Sewer Authority (NHSA) standards, depending on the jurisdiction.
- C. This section of the specifications may be used in conjunction with the utility-specific sections of the specifications; however, the requirements found in the utility-specific sections take precedence over those of this section. Utility-specific sections of the specifications can be found under Division 33.
- D. The Construction Manager reserves right to require cores to be drilled for compressive strength tests.
- E. Maintain one (1) copy of each document on-site.
- F. Manufacturer: Company specializing in manufacturing products specified in this Section with minimum three (3) years of documented experience.
- G. Inspection by Construction Manager:
 1. At site of work after delivery.
 2. Reject precast concrete manhole or structure at any time if it fails to meet specified requirements, even if accepted at plant.
 3. Immediately mark rejected precast concrete manholes and structures and remove them from the site.

1.08 DELIVERY, STORAGE AND HANDLING

- A. Comply with the requirements specified in Section 016100.
- B. Comply with precast concrete manufacturer's instructions for unloading, storing and moving precast manholes and structures.
- C. Store precast concrete manholes and structures to prevent damage to all property. Repair property damaged from materials storage.
- D. Mark each precast manhole and structure by indentation or waterproof paint showing date of manufacture, manufacturer, and identifying symbols and numbers shown on Contract Drawings to indicate its intended use.

1.09 PROJECT/SITE CONDITIONS

- A. Maintain materials and surrounding air temperatures to minimum 50 degrees F prior to, during, and 48 hours after completion of masonry work.

PART 2 - PRODUCTS

2.01 MANHOLES AND STRUCTURES

- A. Precast Manhole: Reinforced precast concrete in accordance with ASTM C478/C478M with gaskets in accordance with ASTM C923/C923M.
- B. Precast Catch Basins and Inlets: Reinforced precast concrete in accordance with ASTM C913/C913M with gaskets in accordance with ASTM C923/C923M.
- C. Concrete Block Manhole: Manufacture concrete block according to ASTM C139. Use cement as specified in Section 033000 and aggregates conforming to the requirements for concrete aggregates as specified in Section 033000. Sample and test concrete block according to ASTM C140. Manufacture blocks to be either rectangular in shape or curved with the inside and outside surfaces curved to the required radii, whichever is appropriate for the shape of the structure. Ensure that the length is between 12 and 18 inches, the height is between 5 and 8 inches, and the width is at least 6 inches. For the reduction of cross-sectional area of the cones or tops of manholes, the Contractor may use blocks of special shapes and heights. The Contractor may also use blocks of special shapes and heights in the top courses of all structures so that the head casting is set at the required elevation on a mortar bed not more than 1/2-inch thick without cutting the blocks. Ensure that all blocks have an interlocking-type joint at the ends and are sound and free from cracks or other defects.
- D. Reinforcement Steel: Deformed bars and plain or deformed steel welded wire reinforcement as specified in Section 032100.
- E. Base Pad for Precast Manhole: Reinforced precast concrete in accordance with ASTM C478/C478M, level top surface, with thickness as shown on Contract Drawings.
- F. Base Pad for Precast Catch Basins and Inlets: Reinforced precast concrete in accordance with ASTM C913/C913M, level top surface, with thickness as shown on Contract Drawings.
- G. Base Pad for Concrete Block Structures: Reinforced cast-in-place concrete as specified in Section 033000, level top surface with thickness as shown on Contract Drawings.
- H. Coating: For use below ground level, use an asphalt waterproofing conforming to ASTM D449, Type I. Use a primer conforming to ASTM D41.

- I. Area Drains: Size as indicated in the Contract Drawings. The area drain shall be manufactured from PVC pipe stock, utilizing a thermo-molding process to reform the pipe stock to the finished configuration. The drainage pipe connection stubs shall be manufactured from PVC pipe stock and formed to provide a watertight connection with the piping system specified. Joint tightness shall conform to ASTM D 3212. The pipe connection stubs shall be joined to the main body of the area drain utilizing a watertight, gasketed, swedged-type connection. The pipe stock used to manufacture the main body and pipe stubs of the area drains shall meet ASTM D 3034. The swedge gasket material and the gaskets used to form the connecting joint with the pipe stub shall meet the requirements of ASTM F 477. Area drains shall meet the mechanical property requirements for fabricated fittings as described in ASTM F 794, ASTM F 949, and ASTM F 1336. The grates furnished for all area drains shall be made specifically for each fitting. Grate material, type and size shall be as noted in the Contract Drawings.
- J. Cleanouts: As indicated in the contract documents.
- K. Drywells: As indicated in the contract documents.

2.02 GRATES, FRAMES AND COVERS

- A. Manufacturers:
 - 1. Campbell Foundry Co.
 - 2. Neenah Foundry Co.
 - 3. U.S. Foundry Co.
 - 4. Or approved equal.
- B. Frames and covers: ASTM A48/A48M, Class 30B or Class 35B gray iron or ASTM A536, Grade 65-45-12 or Grade 80-55-06 ductile iron construction, machined flat bearing surface, removable watertight lockable lid, with cover molded with identifying name and logo in accordance with the jurisdiction of the structure. Sandblast or clean the castings to remove sand and scale.
- C. In areas noted on drawings, water-tight, locking frames and covers shall be installed. Casting shall be equipped with ¼” neoprene gasket or other approved seal. Locking device shall be “camlock” style or approved equal capable of securing lid against uplift pressure of up to 8 psi.
- D. Extension frames and rings: Use carbon steel extension frames and rings for inlets and manholes. Perform welding of fabricated steel shapes and structures according to AWS D1.1. Do not punch, drill, ream, weld, or cut extension frames and rings in the field.

- E. Atrium Grates: The grates furnished for landscape areas and combination overflow risers shall be made specifically for each fitting. Grates shall be either cast iron or ductile iron with size as indicated in the Contract Drawings.
 - 1. Nyloplast 7001 110 Dome Grate Series
 - 2. Ulma Architectural Solutions
 - 3. Reliance Foundry
 - 4. Or approved equal.

- F. Pedestrian Grates: The grates furnished for dog park areas shall be, ADA, finish in accordance with Landscape Architect specifications. Grates shall be made specifically for each fitting. Grates shall either be cast iron or ductile iron with size as indicated in the Contract Drawings. Basis of design products include:
 - 1. Nyloplast 7001 110 Pedestrian Grate Series
 - 2. Ulma Architectural Solutions
 - 3. Reliance Foundry
 - 4. Or approved equal.

- G. Flat Grates: The grates furnished for pavement areas shall be, heel proof, ADA, with a concentric design, finish in accordance with Landscape Architect specifications. Grates shall be made specifically for each fitting. Grates shall either be cast iron or ductile iron with size as indicated in the Contract Drawings. Basis of design products include:
 - 1. Iron Age Designs Bullseye 12”x12” Heal-Proof Catch Basin Grate
 - 2. Ulma Architectural Solutions
 - 3. Reliance Foundry
 - 4. Or approved equal.

2.03 COMPONENTS

- A. Ladder rungs: For ladder rungs, use steel reinforced copolymer polypropylene. Use a 1/2-inch diameter reinforcement steel bar conforming to ASTM A615, Grade 60, and a polypropylene coating conforming to classification PP0344B33534Z02 according to ASTM D4101.

- B. Epoxy bedding compound: Use a 2-part, non-sag gel, rapid-setting epoxy adhesive conforming to ASTM C881, Type 4, Grade 3, Class B or C. Use the epoxy in an ambient temperature range of 40 to 100 degrees F.
- C. Mortar: Mix one (1) part cement to two (2) parts fine aggregate. Add water to form the proper consistency. Do not temper mortar or use mortar after it has begun to set.
- D. Strap Anchors: Bent steel shape, 3/8-inch thick, galvanized according to ASTM A123.
- E. Resilient Connectors: Use a watertight resilient pipe connector conforming to ASTM C923 at manholes.

2.04 CONFIGURATION

- A. Manhole Shaft Construction: Concentric with concentric or eccentric cone top section; lipped male/female dry joints; sleeved to receive pipe sections.
- B. Manhole Shape: Cylindrical.
- C. Manhole Clear Inside Dimensions: 48-inch minimum diameter or as indicated on Contract Drawings.
- D. Minimum Design Depth: 18 inches or as indicated on Contract Drawings.
- E. Manhole Clear Cover Opening: 25 3/8 inches diameter or as indicated on Contract Drawings.
- F. Catch Basins and Inlets: Shape and dimensions as indicated on Contract Drawings.
- G. Pipe Entry: Furnish openings as indicated on Contract Drawings.
- H. Steps: 16 inches wide, 12 inches on center vertically, set into manhole and structure wall as indicated on Contract Drawings.

2.05 BEDDING AND COVER MATERIALS

- A. Bedding (Jersey City Standards): Coarse aggregate, No. 67, nominal size 3/4-inch crushed stone or washed gravel as indicated on the Contract Drawings, and as specified in Section 312300.
- B. Bedding (NHSA Standards & All Others): Coarse aggregate No. 57, nominal size 1-inch crushed stone as indicated on the Contract Drawings, and as specified in Section 312300.
- C. Backfill: Suitable material as specified in Section 312300 that is free from rock larger than 2 inches in diameter, frozen earth and foreign matter.

- D. Alternate Backfill: CLSM if approved by the Architect/Engineer and the Utility with jurisdiction.

PART 3 - EXECUTION

3.01 EXAMINATION

- A. Verify existing conditions before starting Work.
- B. Verify items provided by other sections of Work are properly sized and located.
- C. Verify built-in items are in proper location, and ready for roughing into Work.
- D. Verify correct size of manhole and structure excavation.

3.02 PREPARATION

- A. Coordinate placement of inlet and outlet pipe or duct sleeves required by other sections.
- B. Do not install structures where site conditions induce loads exceeding structural capacity of structures.
- C. Inspect precast concrete structures immediately prior to placement in excavation to verify structures are internally clean and free from damage. Remove and replace damaged units.

3.03 INSTALLATION

- A. Excavation and Backfill:
 - 1. Sawcut asphalt and concrete and excavate for manholes and structures. Provide clearance around sidewalls of structure for construction operations.
 - 2. When groundwater is encountered, prevent accumulation of water in excavations. Place manholes and structures in dry trench. Do not allow standing water in excavations.
 - 3. Where possibility exists of watertight structure becoming buoyant in flooded excavation, anchor structure to avoid flotation.
 - 4. Obtain Construction Manager approval before finishing excavating. If the Construction Manager determines that the bottom of the excavation is unstable, undercut, backfill with coarse aggregate No. 57, and compact as directed by the Construction Manager.
 - 5. Maintain excavations in accordance with 29 CFR 1926.

6. Backfill excavations for manholes and structures in accordance with Section 312300 and as shown on Contract Drawings.
- B. Install manholes and structures on bedding layer of specified material and thickness.
 1. When following Jersey City Standards:
 - a. Install precast sanitary manholes on a 12-inch-thick layer of coarse aggregate No. 67, ¾-inch crushed stone.
 - b. Install concrete block manholes on an 8-inch-thick layer of coarse aggregate No. 67, ¾-inch crushed stone.
 - c. Install catch basins, all types, on an 8-inch-thick layer of coarse aggregate No. 67, ¾-inch washed gravel.
 2. When following NHSA Standards, and for all other structures:
 - a. Install manholes on a minimum 8-inch-thick layer of coarse aggregate No. 57, 1-inch crushed stone.
 - b. Install inlets on a layer of coarse aggregate No. 57, 1-inch crushed stone, minimum layer thickness as shown on the Contract Drawings.
 - C. Place base pad and ensure top surface is level.
 - D. Place manhole and structure sections plumb and level, trim to correct elevations, anchor to base pad, fill lifting holes with mortar.
 - E. Install manholes and structures supported at proper grade and alignment.
 - F. For cast-in-place concrete manholes and structures, place manhole and structures cylinder plumb and level, to correct dimensions and elevations.
 - G. Cut and fit for conduit and sleeves.
 - H. Grout base of shaft sections to achieve slope to exit piping. Trowel smooth. Contour to form continuous drainage channel that conforms uniformly with inlet and outlet pipes.
 - I. Apply one coat of primer and two coats of asphalt cement waterproofing to the outside surface of walls below ground level according to the manufacturer's recommendations.
 - J. Set cover frames and covers level without tipping, to correct elevations.
 - K. Coordinate with other sections of Work to provide correct size, shape, and location.

3.04 MASONRY MANHOLE AND STRUCTURE INSTALLATION

- A. Maintain masonry courses to uniform dimension. Form vertical and horizontal joints of uniform thickness not to exceed 3/8 inch wide.
- B. Lay masonry units in running bond. Course one unit and one mortar joint to equal 8 inches.
- C. Form flush mortar joints.
- D. Lay masonry units in full bed of mortar, with full head joints, uniformly jointed with other Work.
- E. Install joint reinforcement 16 inches on center.
- F. Additionally, place joint reinforcement in first and second horizontal joints above base pad and below cover frame opening.
- G. As work progresses, build in fabricated metal items.
- H. Coat the outside and inside walls with at least a 1/2-inch-thick layer of mortar and trowel smooth.
- I. Cut and fit for conduit and sleeves. Ensure that the connection between manhole or structure and pipe or conduit is leak-free.
- J. When the ambient temperature is below 40 degrees F, ensure that the mortar temperature is between 50 and 100 degrees F.
- K. Cover the masonry and maintain its temperature above 32 degrees F for 24 hours. Ensure that mortar attains a strength of 2500 pounds per square inch before opening to traffic.
- L. Grout base of shaft sections to achieve slope to exit piping. Trowel smooth. Contour to form continuous drainage channel.
- M. Coordinate with other sections of Work to provide correct size, shape, and location.

3.05 PRECAST CONCRETE MANHOLE AND STRUCTURE INSTALLATION

- A. Lift precast components at lifting points designated by manufacturer.
- B. When lowering manholes and structures into excavations and joining pipe to units, take precautions to ensure interior of pipeline and structure remain clean.
- C. Set precast structures bearing firmly and fully on bedding layer, using materials and thickness listed herein at Subsection 3.03.B and compacted in accordance with provisions of Section 312300.

- D. Assemble multi-section structures by lowering each section into excavation. Lower, set level, and firmly position base section before placing additional sections.
- E. Remove foreign materials from joint surfaces and verify sealing materials are placed properly. Maintain alignment between sections by using guide devices affixed to lower section.
- F. Joint sealing materials may be installed on site or at manufacturer's plant.
- G. Verify manholes and structures installed satisfy required alignment and grade.
- H. At pipe to manhole connections, use watertight resilient connectors.
- I. Remove knockouts or cut structure to receive piping without creating openings larger than required to receive pipe. Fill annular space with mortar.
- J. Cut pipe to finish flush with interior of structure.
- K. Shape inverts through manhole and structures.

3.06 CAST-IN-PLACE CONCRETE MANHOLE AND STRUCTURE INSTALLATION

- A. Erect and brace forms against movement in accordance with Section 031000.
- B. Install reinforcement steel as indicated on Contract Drawings and in accordance with Section 032100.
- C. Place and cure concrete in accordance with Section 033000.
- D. At pipe to manhole connections, use watertight resilient connectors.

3.07 FRAME AND COVER INSTALLATION

- A. Set frames using epoxy bedding compound. Install radially laid concrete brick with 1/4-inch thick vertical joints at inside perimeter. Lay concrete brick in full bed of mortar and completely fill joints. Where more than one course of concrete brick is required, stagger vertical joints.
- B. Set frame and cover 2 inches above finished grade for manholes and structures with covers located within unpaved areas to allow area to be graded away from cover beginning 1-inch below top surface of frame.
- C. Set cover frames and covers level without tipping, to correct elevations before finishing adjoining work with the same final elevation. If the cover or grate is loose or wobbles, grind to obtain a tight fit.

3.08 VERTICAL ADJUSTMENT OF EXISTING MANHOLES AND STRUCTURES

- A. Where required, adjust top elevation of existing manholes and structures to finished grades shown on Contract Drawings.
- B. Reset existing frames, grates and covers, carefully removed, cleaned of mortar fragments, to required elevation in accordance with requirements specified for installation of castings.
- C. Remove concrete without damaging existing vertical reinforcement when removal of existing concrete wall is required. Clean vertical bars of concrete and bend into new concrete top slab or splice to required vertical reinforcement, as indicated Contract Drawings.
- D. Clean and apply sand-cement bonding compound on existing concrete surfaces to receive cast-in-place concrete in accordance with Section 033000.

3.09 CLEANOUT INSTALLATION

- A. Install in accordance with manufacturer's recommendations.

3.10 DRYWELL INSTALLATION

- A. Install in accordance with the contract documents.

3.11 FIELD QUALITY CONTROL

- A. Section 014300: Field inspecting, testing, adjusting, and balancing.
- B. Test cast-in-place concrete in accordance with Section 033000.
- C. Ensure that manholes and castings, and manhole-to-pipe connections are watertight.

3.12 CONTRACT CLOSEOUT

- A. Provide in accordance with Section 017700.

END OF SECTION 333915

NO TEXT ON THIS PAGE

SECTION 334000 - STORM DRAINAGE UTILITIES

PART 1 - GENERAL

1.01 SUMMARY

- A. This Section specifies storm drainage systems and excludes interceptors, storm separators, or subdrainage.

1.02 PAYMENT

- A. No separate payment shall be made for performing any Work required under this Section. All costs for Work required by this Section shall be included in the applicable lump sum(s), unit price(s), or allowance(s) as set forth in Section 012901.

1.03 DESCRIPTION

- A. Provide storm drainage utilities as indicated and in compliance with Contract Documents.
- B. Section includes:
 - 1. Storm drainage piping, fittings, and accessories.
 - 2. Storm drainage catch basins, inlets, manholes, or other structures.

1.04 REFERENCES

- A. American Association of State Highway and Transportation Officials (AASHTO):
 - 1. M198: Standard Specification for Joints for Concrete Pipe, Manholes, and Precast Box Sections Using Preformed Flexible Joint Sealants.
 - 2. M294: Standard Specification for Corrugated Polyethylene Pipe.
- B. ASTM International (ASTM):
 - 1. A48/A48M: Standard Specification for Gray Iron Castings.
 - 2. A74: Standard Specification for Cast Iron Soil Pipe and Fittings.
 - 3. A123/A123M: Standard Specification for Zinc (Hot-Dip Galvanized) Coatings on Iron and Steel Products.
 - 4. A536: Standard Specification for Ductile Iron Castings.

5. A716: Standard Specification for Ductile Iron Culvert Pipe.
6. C32: Standard Specification for Sewer and Manhole Brick (Made from Clay or Shale).
7. C76: Standard Specification for Reinforced Concrete Culvert, Storm Drain, and Sewer Pipe.
8. C139: Standard Specification for Concrete Masonry Units for Construction of Catch Basins and Manholes.
9. C150: Standard Specification for Portland Cement.
10. C207: Standard Specification for Hydrated Lime for Masonry Purposes.
11. C361: Standard Specification for Reinforced Concrete Low-Head Pressure Pipe.
12. C425: Standard Specification for Compression Joints for Vitrified Clay Pipe and Fittings.
13. C443: Standard Specification for Joints for Concrete Pipe and Manholes, Using Rubber Gaskets.
14. C478: Standard Specification for Precast Reinforced Concrete Manhole Sections.
15. C564: Standard Specification for Rubber Gaskets for Cast Iron Soil Pipe and Fittings.
16. C700: Standard Specification for Vitrified Clay Pipe, Extra Strength, Standard Strength, and Perforated.
17. C890: Standard Practice for Minimum Structural Design Loading for Monolithic or Sectional Precast Concrete Water and Wastewater Structures.
18. C923: Standard Specification for Resilient Connectors Between Reinforced Concrete Manhole Structures, Pipes, and Laterals.
19. C990: Standard Specification for Joints for Concrete Pipe, Manholes, and Precast Box Sections Using Preformed Flexible Joint Sealants.
20. D698: Standard Test Methods for Laboratory Compaction Characteristics of Soil Using Standard Effort (12 400 ft-lbf/ft³ (600 kN-m/m³))
21. D1785: Standard Specification for Poly(Vinyl Chloride) (PVC) Plastic Pipe, Schedules 40, 80, and 120.

22. D2680: Standard Specification for Acrylonitrile-Butadiene-Styrene (ABS) and Poly(Vinyl Chloride) (PVC) Composite Sewer Piping
23. D2729: Standard Specification for Poly(Vinyl Chloride) (PVC) Sewer Pipe and Fittings.
24. D2751: Standard Specification for Acrylonitrile-Butadiene- Styrene (ABS) Sewer Pipe and Fittings.
25. D3034: Standard Specification for Type PSM Poly(Vinyl Chloride) (PVC) Sewer Pipe and Fittings.
26. D3212: Standard Specification for Joints for Drain and Sewer Plastic Pipes Using Flexible Elastomeric Seals.

1.05 RELATED SECTIONS

- A. General Conditions Article 4.7 – Shop Drawing and Other Submittals
- B. Section 012901 – Measurement and Payment
- C. Section 014300 – Quality Requirements
- D. Section 016100 – Control of Materials
- E. Section 017700 – Contract Closeout
- F. Section 033000 – Cast-in-Place Concrete
- G. Section 312300 - Excavation and Fill
- H. Section 333915 – Manholes and Structures

1.06 DEFINITIONS

- A. Catchbasin: A special type of inlet structure designed to retain sediment and debris transported by stormwater into the storm drainage system.
- B. Manhole: A structure designed to connect rigid piping and to allow access for maintenance.

1.07 SUBMITTALS

- A. Submit the following in accordance with General Conditions Article 4.7.
 1. Shop Drawings:

- a. Precast Concrete Structures: Indicate locations, dimensions, configuration, thicknesses, elevations, sizes, and penetration elevations.
 - b. Area drains: Indicate locations, dimensions, configuration, elevations, sizes, penetration elevations and grate type.
2. Product Data:
 - a. Pipe: Material, pipe accessories, and manufacturer’s installation instructions.
 - b. Structures: Manufacturer’s standard drawings or catalog cuts for precast concrete manholes, catch basins, and other structures; frame, cover and grates; cleanout ring and cover, and area drains, and area drain grates and grate inlet capacity information.
 - c. Miscellaneous Items: Backwater valve.
 3. Certificates: Manufacturer’s certificate stating that product meets or exceeds specified requirements.
 4. Project Record Documents: Provide record drawings of actual pipe run locations, connections, structures, and invert elevations.
 5. Testing Results.
- 1.08 QUALITY ASSURANCE
- A. Comply with the requirements specified in Section 014300.
- 1.09 DELIVERY STORAGE AND HANDLING
- A. Comply with the requirements specified in Section 016100.

PART 2 - PRODUCTS

2.01 PIPE MATERIALS

- A. Ductile Iron Culvert Pipe: ASTM A716; nominal inside diameter as indicated.
- B. Reinforced Concrete Pipe (RCP):
 1. Pipe: ASTM C76, minimum Class III, unless noted otherwise; nominal inside diameter as indicated.
 2. End Joints: Tongue and groove.

3. Joint Device:
 - a. Watertight: ASTM C443, rubber compression gasket.
- C. Plastic Pipe (ABS):
 1. Pipe: ASTM D2751, SDR 35, Acrylonitrile-Butadiene-Styrene (ABS) material; nominal inside diameter as indicated.
 2. End Joints: Bell and spigot.
 3. Joint Device: Solvent sealed joint.
- D. Plastic Pipe (PVC):
 1. Pipe: ASTM D2729, Polyvinyl Chloride (PVC) material; nominal inside diameter as indicated.
 2. End Joints: Bell and spigot.
 3. Joint Device: Solvent sealed joint.
- E. Plastic Pipe (PVC):
 1. Pipe: ASTM D1785, Schedule 80, PVC material; nominal inside diameter as indicated.
 2. End Joints: Bell and spigot.
 3. Joint Device: Solvent sealed joint.
- F. Plastic Pipe (HDPE):
 1. Pipe: AASHTO M294, Type S; high density polyethylene (HDPE) material; smooth interior and annular-corrugated exterior.
 2. End Joints: Bell and Spigot, bell shall be an integral part of the pipe and shall be watertight.
 3. Joint Type: Gasket, pipe gaskets shall be manufacturer installed.
- G. Plastic Perforated Underdrain Pipe (PVC):
 1. Pipe and fittings: ASTM D 3034, SDR 26; nominal inside diameter as indicated per plan.
 2. Perforations: ASTM F 758, Type PS 46

3. End Joints: Bell and spigot
4. Joint Device: Solvent sealed joint.

2.02 CATCHBASINS

- A. Refer to Section 333915.
- B. Precast or cast-in-place drainage structure.
- C. No sump shall be provided unless noted otherwise or as shown on the Contract Drawings.
- D. In Jersey City, all catchbasins shall be constructed with minimum 2-foot deep sediment sumps and standard type catchbasin traps as manufactured by Campbell Foundry, Reliance Foundry Co., U.S. Foundry Co., or approved equal.

2.03 PRECAST STRUCTURES

- A. Refer to Section 333915.
- B. Manhole Sections: Reinforced precast concrete in accordance with ASTM C478/C478M), with resilient connectors complying with ASTM C923/C923M.
- C. Pipe Connections: Grout pipe at manhole to form a watertight connection. Storm drains 42 inches and smaller, ASTM C923. Storm drains larger than 42 inches, grout 4 feet spool piece into place on manhole. Connect pipe to spool piece using flexible connection.
- D. Joints: ASTM C443/C443M, watertight.

2.04 CAST-IN-PLACE STRUCTURES

- A. Refer to Section 333915.
- B. Materials:
 1. Concrete: Section 033000, minimum compressive strength of 4,000 psi.
 2. Portland Cement: ASTM C150, Type II.
 3. Hydrated Lime: ASTM C207, Type S.
 4. Sand: ASTM C33, Fine Aggregate, except all passes No. 8 sieve.
 5. Water: Potable, not detrimental to concrete.
 6. Brick: ASTM C32, Grade MS, maximum 8 percent absorption computed from average of five (5) cycles.

7. Precast Concrete Masonry Units: ASTM C139, precast machine-made solid segments with the following:
 - a. Use Type II cement except as otherwise permitted.
 - b. Width of units as indicated.
 - c. Inside and outside surfaces of units curved to necessary radius; interior surfaces of structures cylindrical, except top batter courses to reduce inside section of structure uniformly to required size and shape at top.
 - d. Only full-length units required to lay anyone (1) course.
 - e. Accept units on basis of material tests and inspection of completed product.

C. Components:

1. Bases: Cast-in-place concrete, one-piece, precast segmental plates, as indicated.
2. Walls: Precast Concrete Masonry Units.
3. Top of Cone: Brickwork for adjusting frame to meet finished surface shall not exceed 6 inches.
4. Frames and Grates: As indicated and specified.

D. Mixes:

1. Concrete: Section 033000.
2. Mortar for Brickwork: Mix Portland cement, hydrated lime and sand. Volume of sand not to exceed three (3) times sum of volumes of cement and lime. Proportion cement and lime as directed. Cement to lime proportions may vary between one (1) part cement to 1/4-part lime for dense hard burned brick, and one (1) part cement to 3/4-part lime for softer brick. Mix mortar in proportion of one (1) part cement to 1/2-part lime to 4-1/2 parts sand. Use sufficient water to form a workable mixture.
3. Mortar for Masonry Units: Mix one (1) part Portland cement and two (2) parts of sand by volume with sufficient water to form a workable mixture.

2.05 MIXES

- A. Mortar for Plugging Lift Holes: Mix Portland cement and sand, one (1) part cement to 1/2-part sand with sufficient water to make mortar damp without "balling".

2.06 MISCELLANEOUS STRUCTURES

- A. Area Drain: Refer to Section 333915.
- B. Combination Overflow Riser: Area Drains as indicated herein.
- C. Cleanouts: As indicated in the Contract Drawings.
- D. Atrium Grates: Refer to Section 333915.
- E. Pedestrian Grates: Refer to Section 333915.
- F. Flat Grates: Refer to Section 333915.
- G. Flow Control Device Assembly
 - 1. Pipe: ASTM D1785, Schedule 40
 - 2. Orifice Plate: PVC, fusion welded to the PVC pipe or elbow with an orifice of the diameter indicated on the Contract Drawing in the center. Orifice Plate may be eliminated where the orifice size matches the size of the fitting.
- H. Backwater Valve: Elastomer slip-on check valve with stainless steel clamps
 - 1. Tideflex TF-2 by Red Valve Tideflex Technologies
 - 2. Wapro Inc.
 - 3. Proco ProFlex Products Inc.
 - 4. Or approved equal.

2.07 COMPONENTS

- A. Frame and Cover: ASTM A48 A48M /, Class 30B cast iron construction or ASTM A536, Grade 60-40-18 ductile iron construction. Machined flat bearing surface, removable lid; rated for ASTM C890, A-16 AASHTO HS20-44 loading, unless noted otherwise. Castings shall be as follows:
 - 1. Free from scale, lumps, blisters, and sand-holes.
 - 2. Machine contact surfaces to prevent rocking.
 - 3. Thoroughly clean and hammer inspect.
- B. Manhole Steps: ASTM C478.

PART 3 - EXECUTION

3.01 TRENCHING

- A. See Section 312300 for additional requirements.
- B. Hand trim excavation for accurate placement of pipe to indicated elevations.

3.02 CATCHBASINS AND CLEANOUTS

- A. Form bottom of excavation, clean and smooth and to correct elevation.
- B. Provide bedding in accordance with Section 312300 as indicated.
- C. Place structure plumb and level on prepared bedding.
- D. Orient structure for pipe connections.
- E. Form and place cast-in-place concrete base pad.
- F. Level the top surface of base pad and sleeve concrete shaft sections to receive storm drainage pipe sections.
- G. Establish elevations and pipe inverts as indicated.
- H. Establish top elevation and mount frame and cover.
- I. Mount frame level in grout, secured to top cone section.

3.03 PRECAST STRUCTURES

- A. Provide bedding according to Section 312300 as indicated.
- B. Place manhole sections plumb and level on prepared bedding. Orient manhole to allow for connection with pipe. Trim to correct elevation.

3.04 CAST-IN-PLACE STRUCTURES

- A. Brickwork and Masonry Units:
 - 1. Use clean units.
 - 2. Bricks:
 - a. Moisten bricks to prevent absorption of water from mortar. Limit moisture to prevent bricks from becoming slippery during placement.

- b. Lay each brick in full bed and joint of mortar without requiring subsequent grouting, flushing or filling; bond thoroughly.
 3. Concrete Masonry Units:
 - a. Do not moisten concrete masonry units.
 - b. Lay each masonry unit in full bed of mortar; bond thoroughly. Fill vertical keyways, completely, with mortar.
 - B. Plastering and Curing Brick Masonry
 1. Plaster outside faces with mortar 1/4- to 3/8-inch thick.
 2. Moisten brick masonry before application of mortar, if required.
 3. Spread and trowel plaster carefully.
 4. Check for bond and soundness after hardening, by tapping.
 5. Remove and replace unbonded and unsound plaster.
 6. Protect from too rapid drying by use of moist burlap or other accepted means.
 7. Protect from weather and frost.
 - C. Setting Frames, Grates, and Curb Inlets:
 1. Set inlets and frames with tops conforming accurately to finished ground or pavement surface as indicated and directed.
 2. Set circular frames concentric with top of masonry.
 3. Set frames in full bed of mortar to fill and make watertight completely the space between top of masonry and bottom flange of the frame.
 4. Place a thick ring of mortar extending to the outer edge of masonry, around bottom flange. Finish mortar smoothly and give a slight slope to shed water away from the frame.
 5. Place grates in the frames after completing all other work at the structure.
- 3.05 MISCELLANEOUS STRUCTURES
- A. Area Drains:
 1. Install in accordance with manufacturer's recommendations.

B. Cleanouts:

1. Install in accordance with manufacturer's recommendations.

C. Backwater Valve:

1. Install in accordance with manufacturer's recommendations.

3.06 FIELD QUALITY CONTROL

A. Remove work that does not pass tests; replace and retest until successful installation is achieved.

1. Construction Manager will test pipe for displacement after trench has been backfilled and compacted, and after pipe has been cleaned of silt and debris.
2. Construction Manager will visually inspect pipe. Pipes that do not present a uniform bore due to displacement and misalignment shall be replaced.

B. Deflection Test:

1. Test pipes for vertical ring deflection within 15 days after completion of backfill at least four (4) months after installation but not later than 30 days before estimated substantial completion.
2. Maximum allowable ring deflection is 5 percent of vertical internal pipe diameter.
3. Replace pipe exceeding this allowable deflection.
4. Make deflection tests with deflectometer which produces a continuous record of pipe deflection by pulling mandrel, sphere, or pin-type go/no-go device through pipe. Make the diameter of go/no-go device to be 95 percent of the undeflected inside pipe diameter.

3.07 PROTECTION

A. Protect pipe and bedding from damage or displacement until backfilling operation is completed.

3.08 CONTRACT CLOSEOUT

A. Provide in accordance with Section 017700.

END OF SECTION 334000

NO TEXT ON THIS PAGE

SECTION 334229 - SLIP-IN INLINE CHECK VALVES

PART 1 - GENERAL

1.01 DESCRIPTION

- A. Provide slip-in inline check valves as indicated and in compliance with the Contract Documents.

1.02 PAYMENT

- A. No separate payment shall be made for performing any Work required under this Section. All costs for Work required by this Section shall be included in the applicable lump sum as set forth in Section 012901.

1.03 RELATED SECTIONS

- A. General Conditions Article 4.7 – Shop Drawings and Other Submittals
- B. Section 012901 – Measurement and Payment
- C. Section 014300 – Quality Assurance
- D. Section 016100 – Control of Materials
- E. Section 017700 – Contract Closeout

1.04 SUBMITTALS

- A. Comply with the requirements specified in General Conditions Article 4.7.

1.05 QUALITY ASSURANCE

- A. Provide in accordance with Section 014300 and as specified.

1.06 DELIVERY, STORAGE AND HANDLING

- A. Comply with the requirements specified in Section 016100.

PART 2 - PRODUCTS

2.01 SLIP-IN INLINE CHECK VALVES

- A. Manufacturers

1. Checkmate Ultraflex check valve produced by Tideflex Technologies, 750 Holiday Drive, Pittsburgh, PA 15220
 2. Wastop check valve produced by Wapro Inc., 150 North Michigan Avenue, Chicago, IL 60601.
 3. Check valve by Proco ProFlex Products Inc.
 4. Or approved equal.
- B. Check valve to be all rubber, flow operated with slip-in cuff connection. The valve shall not be manufactured with metal, mechanical hinges or fasteners. Entire valve shall be ply reinforced throughout body, bill and saddle. Valve shall be cured and vulcanized to provide one-piece unibody construction. The port area of the saddle shall contour into a circumferential sealing area (the bill) concentric with the pipe, which shall allow flow to pass in one direction and prevent it in the opposite. The outside diameter of the upstream and downstream sections of the valve shall be circumferentially in contact with the inside diameter of the pipe.

PART 3 - EXECUTION

3.01 INSTALLATION

- A. The valve shall be installed in accordance with the manufacturer's instructions, Operation Manual and approved submittals.

3.02 CONTRACT CLOSEOUT

- A. Provide in accordance with Section 017700.

END OF SECTION 334229

SECTION 334235 – FLAP GATE CHECK VALVES

PART 1 - GENERAL

1.01 DESCRIPTION

- A. Provide flap gate check valves as indicated and in compliance with the Contract Documents.

1.02 PAYMENT

- A. No separate payment shall be made for performing any Work required under this Section. All costs for Work required by this Section shall be included in the applicable lump sum as set forth in Section 012901.

1.03 RELATED SECTIONS

- A. General Conditions 4.7 – Shop Drawings and Other Submittals
- B. Section 012901 – Measurement and Payment
- C. Section 014300 – Quality Assurance
- D. Section 016100 – Control of Materials
- E. Section 017700 – Contract Closeout

1.04 SUBMITTALS

- A. Comply with the requirements specified in General Conditions 4.7
- B. Flap Valve and all components
- C. Flow characteristics including head loss and closure criteria.

1.05 QUALITY ASSURANCE

- A. Provide in accordance with Section 014300 and as specified.

1.06 DELIVERY, STORAGE AND HANDLING

- A. Comply with the requirements specified in Section 016100.

PART 2 - PRODUCTS

2.01 FLAP GATE CHECK VALVES

A. Manufacturers

1. F-40 Heavy Duty flap gate check valve produced by Waterman Valve, LLC, 25500 Road 204, Exeter, CA 93221.
2. FR-40 flap gate check valve produced by Rodney Hunt, 46 Mill Street, Orange, MA 01364.
3. Flap gate valve by Hydro Gate, a Mueller Company.
4. Or approved equal.

B. Construction

1. Frame shall be cast of flatback design, with seating surface inclined from vertical at a minimum of 2.5 degrees to assure positive closure. For flatback gates mounted to thimbles or flanges, the gate flange shall be machined and drilled to match.
2. Cover shall be cast iron, cast in one piece, with reinforcing ribs, designed to withstand the seating head specified. An integral cast-on lifting eye shall be provided for manual operation. All machined surfaces shall have a minimum 63 micro inch finish.
3. Seating surfaces for frame and cover shall be one of the following:
 - a. Machined iron.
 - b. Bronze seats impacted into dovetail grooves on the frame and cover.
 - c. Bronze seats impacted into dovetail grooves within the frame with neoprene seat bonded into a dovetail groove in the cover to cushion the cover upon closing.
 - d. Bronze seats impacted into dovetail grooves in cover with the neoprene seat bonded into the dovetail groove in the frame.
4. Gate shall be provided with an adjustable, double pivoted hinge linkage so designed to permit complete seating, full opening and with stops or other arrangement to prevent the cover from rotating sufficiently to become wedged in the open position. Pivot lugs mounted to the frame shall be adjustable to allow adjustment of hinge links without having to remove the cover from the gate. The hinge links shall be bronzed bushed 316 stainless steel. All assembly hardware shall be 316 stainless steel.

5. Finish of all cast iron shall be painted with manufacturer's standard shop coat paint or specified paint. Structural steel hinge links shall be galvanized. All bronze and stainless steel parts do not require further finish.

PART 3 - EXECUTION

3.01 INSTALLATION

- A. The valve shall be installed in accordance with the manufacturer's instructions, Operation Manual and approved submittals.

3.02 CONTRACT CLOSEOUT

- A. Provide in accordance with Section 017700.

END OF SECTION 334235

NO TEXT ON THIS PAGE

SECTION 334237 – SLIDE GATE VALVES

PART 1 - GENERAL

1.01 DESCRIPTION

- A. Provide self-contained gate valve with yoke and bench operator as indicated and in compliance with the Contract Documents.

1.02 PAYMENT

- A. No separate payment shall be made for performing any Work required under this Section. All costs for Work required by this Section shall be included in the applicable lump sum as set forth in Section 012901.

1.03 RELATED SECTIONS

- A. General Conditions Article 4.7 – Shop Drawings and Other Submittals
- B. Section 012901 – Measurement and Payment
- C. Section 014300 – Quality Assurance
- D. Section 016100 – Control of Materials
- E. Section 017700 – Contract Closeout

1.04 SUBMITTALS

- A. Comply with the requirements specified in General Conditions Article 4.7.

1.05 QUALITY ASSURANCE

- A. Provide in accordance with Section 014300 and as specified.

1.06 DELIVERY, STORAGE AND HANDLING

- A. Comply with the requirements specified in Section 016100.

PART 2 - PRODUCTS

2.01 SLIDE GATE VALVES

- A. Manufacturers

1. A-250 series slide gate valve produced by Waterman Valve, LLC, 25500 Road 204, Exeter, CA 93221
2. A-121 series slide gate valve produced by Rodney Hunt, 46 Mill Street, Orange, MA 01364
3. Slide gate vales by Hydro Gate, a Mueller Company.
4. Or approved equal.

B. Construction

1. Frame and Guide Rails:
 - a. The gate frame shall be composed of aluminum guide rails with UHMW seat/seals upstream and downstream. The seat/seals shall form a tight seal between the frame and the slide (disc). The guides will be of sufficient length to support $\frac{1}{2}$ the height of the slide when in the full open position.
 - b. Yoke shall not deflect more than $\frac{1}{360}$ th of the span under full head break load.
 - c. Seals shall be replaceable without removing the frame from the wall. In the case of embedded gates, they shall be constructed in a manner that allows replacement of the seals without removal of the gate frame from the embedment.
2. Stem and Stem Guide:
 - a. Stem shall be solid 304 stainless steel.
 - b. Guide shall be adjustable with split stem sleeves. Guide shall be spaced per manufacturer's requirements. Stem L/r ratio shall be exceeding 200.
 - c. Stem threads shall be machine cut 29-degree Acme or stub Acme type.
 - d. Nominal diameter of the stem shall not be less than the crest of the threaded portion.
3. Seals:
 - a. The seals shall be self-adjusting. Seals requiring periodic maintenance and adjustments to maintain specified leakage rates will not be permitted.
 - b. The top seal design on upward opening gates consisting of four side seals shall incorporate a self-cleaning wiping function that prevents debris from

building-up above the top seal and causing premature wear of the seats, seals, and gate face.

- c. The UHMW seats shall impinge on the slide (disc) by way of a continuous loop cord seal. Seal designs incorporating resilient seals such as “J-bulb” or “P” seals that come in direct contact with the friction surface of the slide will not be considered.
 - d. The cord seal shall function as a seal between the frame and the UHMW, and as a spring force to maintain contact between the UHMW and the slide (disc).
 - e. The resilient bottom seal shall be set into the invert member of the frame which shall be formed in a manner to protect three sides of the seal only exposing the side that will come in contact with the slide. Disc-mounted invert seals exposing additional surface area will not be permitted.
 - f. The self-adjusting seal system shall provide an allowable leakage rate of no more than .05 gpm per peripheral foot of sealing perimeter for both seating and unseating heads.
4. Slide Cover (Disc):
- a. The slide cover (disc) shall be aluminum plate reinforced with structural shapes welded to the plate.
 - (1) The slide cover shall not deflect more than $1/720^{\text{th}}$ of the span, or 1/32-inch at the sealing surface of the gate under maximum specified head.
 - (2) The stem to gate connection shall be either the clevis type, with structural members welded to the slide and a bolt or bolts to act as a securing method, or a threaded and bolted (or keyed) thrust nut supported in a welded nut pocket.
 - (3) The clevis, or pocket and yoke, of the gate shall be capable of taking, without damage, at least twice the rated thrust output of the operator at 40 pounds of pull on a hand wheel or hand crank, and at locked-rotor stall of a motor operator.
 - (4) The slide cover shall be constructed with vertical and horizontal reinforcement ribs.
 - (5) All welds shall be performed by an AWS-certified welding technician.
5. Anchor Bolts:

- a. Anchor hardware shall be provided by the slide gate manufacturer. Anchor hardware consisting of studs, nuts and washers. The size, quantity, and location of the anchor hardware shall be engineered by the slide gate manufacturer for compatibility with the gate materials.

2.02 SLUICE GATES

A. Manufacturers

1. Rodney Hunt Inc.,
2. Penn-Troy Manufacturing, Inc.,
3. Mueller Water Products, Inc.
4. Or approved equal.

B. Construction

1. Ni-resist sluice gate shall comply with AWWA C560.
 - a. Frame, Slide, Thimble - Ni-Resist ASTM A436, Type 1
 - b. Wedges - Bronze ASTM B-584
 - c. Seat Facings - Bronze ASTM B98 or B21
 - d. Stem - Stainless Steel ASTM A276 Type 316
 - e. Thrust Nut & Lifting Nut - Bronze ASTM B-584
 - f. Pedestal - Stainless Steel 316
 - g. Gate Assembly Bolts & Nuts - Stainless Steel 316
2. Anchor Bolts:
 - a. Anchor hardware shall be provided by the slide gate manufacturer. Anchor hardware consisting of studs, nuts and washers. The size, quantity, and location of the anchor hardware shall be engineered by the slide gate manufacturer for compatibility with the gate materials.

PART 3 - EXECUTION

3.01 INSTALLATION

- A. The valve shall be installed in accordance with the manufacturer's instructions, Operation Manual and approved submittals.
- B. The gate frames shall be installed in a true vertical plane, square and plumb, with no twist, convergence, or divergence between the vertical legs of the guide frame.
- C. The Contractor shall fill any void between the guide frames and the structure with non-shrink grout as shown on the installation drawing and in accordance with the grout manufacturer's recommendations.
- D. The frame cross rail shall be adjusted as required to maintain consistent seal compression across the full width of the gate.

3.02 CONTRACT CLOSEOUT

- A. Provide in accordance with Section 017700.

END OF SECTION 334237

NO TEXT ON THISPAGE

SECTION 335000 - GAS UTILITIES

PART 1 - GENERAL

1.01 DESCRIPTION

- A. This Section includes installing gas mains, valves, vents, service lines, and gas valve boxes, and resetting gas valve boxes.
- B. Only a pre-qualified contractor approved by the Utility may construct or relocate gas mains and appurtenances. Pre-qualified contractors include:
 - 1. J.F. CREAMER & SON, INC.
1701 East Linden Avenue
Linden, New Jersey 07036
Telephone (908) 986-5717
Ted Paliwoda
Cell (201) 481-7018
Tpaliwoda@JFCson.com
 - 2. HENKELS & MCCOY, INC.
512 Elbow Lane
P.O. Box 218
Burlington, New Jersey 08016
Telephone (609) 387-9000
Bob Cacamese
Cell (215) 450-2703
Bcacamese@henkels.com
 - 3. KEMSCO CONSTRUCTION, INC.
139 Harper Street
P.O. Box 10019
Newark, New Jersey 07101
Telephone (973) 733-2255
Ralph Serpe
Cell (973) 418-7851
Kemscoinc@aol.com
 - 4. LANTIER CONSTRUCTION CO.
145 Dey Grove Road
Monroe Twp., New Jersey 08831
William Phillips
Cell (732) 674-7981
Billphillips798@comcast.net

5. MILLER PIPELINE CORP.
378 Whitehead Avenue
South River, New Jersey 08882
Telephone (732) 238-2151
Steve Kasmin
Steve.Kasmin@Millerpipeline.com
6. NAPP-GRECCO COMPANY
1500 McCarter Highway
Newark, New Jersey 07104
Telephone (973) 482-3500
Joseph Napp
Cell (973) 445-3003
Jnapp@Napp-grecco.com
7. FERREIRA CONSTRUCTION CO., INC.
31 Tannery Road
Branchburg, New Jersey 08876
Telephone (908) 534-8655
Tino Garcia
Cell (908) 413-2067
tinog@ferreiraconstruction.com
8. SKODA CONTRACTING
174 Gold Mine Road
Flanders, New Jersey 07836
Mark Daly
Telephone (800) 507-9601
Mdaly@Skodacontracting.com
9. WATERS & BUGBEE, INC.
75 South Gold Drive
Hamilton, New Jersey 08691
Telephone (609) 584-1100
Jeff Waters, President
Jwaters@Watersandbugbee.com
10. DANELLA COMPANIES
2290 Butler Pike
Plymouth Meeting, Pennsylvania 19462
Telephone (610) 397-1139
Bob Brust
Cell (610) 476-1407
Bbrust@danella.com

11. SOUTH STATE, INC.
202 Reeves Road
Bridgeton, New Jersey 08302
www.southstateinc.com
Barry Widrick
bwidrick@southstateinc.com
Telephone (856) 451-5300 ext. 136
12. JOSEPH M. SANZARI, INC.
90 West Franklin Street
Hackensack, New Jersey 07601
Telephone (201) 342-6895
Psarlo@sanzaricompanies.com
13. U.S. PIPELINE
11767 Katy Freeway, Suite 100
Houston, Texas 77079
Telephone (713) 300-2277
Lowell Brien
Lbrien@uspipeline.com
14. UTILITY LINE SERVICES
1302 Conshohocken, Pennsylvania 19428
Telephone (610) 239-0900
Bob Nye
bnye@ulscorp.com
15. NOCAR CONTRACTORS
74 Kossuth Street
Newark, New Jersey 07105
Telephone (551) 206-5628
Nuno Nogueira
Cell (551) 206-5628
nuno@nocarnj.com
16. CROWN PIPELINE
3345 Delsea Drive
P.O. Box 39
Franklinville, New Jersey 08322
Telephone (856) 694-1327
John BonFantino
JBonFantino@crownpipeline.com

1.02 PAYMENT

- A. No separate payment shall be made for performing any Work required under this Section. All costs for Work shown on the plans and required by this Section shall be included in the applicable lump sum(s), unit price(s), or allowance(s) as set forth in Section 012901.
- B. Gas mains or services that require relocation not shown on the plans or directed by the Construction Manager shall be paid for under the Utility Allowance as set forth in Section 012901.

1.03 REFERENCES

- A. American Petroleum Institute (API):
 - 1. Standard 1104: Welding of Pipelines and Related Facilities.
- B. ASTM International (ASTM):
 - 1. A36: Standard Specification for Carbon Structural Steel.
 - 2. A252: Standard Specification for Welded and Seamless Steel Pipe Piles.
 - 3. A123: Standard Specification for Zinc (Hot-Dip Galvanized) Coatings on Iron and Steel Products.
 - 4. A780: Standard Practice for Repair of Damaged and Uncoated Areas of Hot-Dip Galvanized Coatings.
 - 5. C1107: Standard Specification for Packaged Dry, Hydraulic-Cement Grout (Nonshrink).
- C. National Association of Corrosion Engineers (NACE):
 - 1. SP0200: Steel-Cased Pipeline Practices.
- D. Public Service Electric and Gas Company (PSE&G):
 - 1. Construction and Maintenance of Gas Facilities and Related Work, Gas Distribution General Specification No. 2016-D-100.
 - 2. Gas Distribution Standards.
- E. Code of Federal Regulations (CFR):
 - 1. 49 CFR 192 – Transportation of Natural and Other Gas by Pipeline: Minimum Federal Safety Standards.

1.04 DEFINITIONS

- A. Appurtenances: Additional piping items to provide a complete piping system suitable to convey gas as specified and intended. These items may or may not be specified but are necessary to complete the piping system.
- B. Utility: The company, agency, or other entity that provides services.

1.05 RELATED SECTIONS

- A. General Conditions Article 4.7 – Shop Drawings and Other Submittals
- B. Section 012901 – Measurement and Payment
- C. Section 014300 - Quality Requirements.
- D. Section 016100 - Control of Materials.
- E. Section 017700 - Contract Closeout.
- F. Section 021600 - Excess Clean Fill, Contaminated Soil, and Groundwater Management and Disposal.
- G. Section 312200 – Grading.
- H. Section 033000 - Cast-in-Place Concrete.
- I. Section 033400 – Controlled Low Strength Material (CLSM)
- J. Section 312300 - Excavation and Fill.
- K. Section 312319 - Dewatering.
- L. Section 314116 – Steel Sheet Piling.
- M. Section 315000 - Excavation Support Systems.

1.06 SUBMITTALS

- A. Submit the following in accordance with General Conditions Article 4.7.
 - 1. Nonshrink grout.
 - 2. CLSM.
 - 3. Structural steel.

4. Bolts and bolting material.
5. Certificate of compliance for steel pipe sleeves.
6. Casing, spacers and sealers.
7. Temporary protection for excavations.
8. All temporary works.

B. Field Test Reports: Provide results for all testing performed.

1.07 QUALITY ASSURANCE

A. Comply with the requirements specified in Section 014300.

B. Perform work in accordance with PSE&G's Construction and Maintenance of Gas Facilities and Related Work, and PSE&G's Gas Distribution Standards.

1.08 DELIVERY, STORAGE AND HANDLING

A. Comply with the requirements specified in Section 016100.

B. Pick up pipe and appurtenances provided by the Utility from the location directed by the Utility. The Utility may, at its discretion, deliver certain materials. Coordinate pickup and delivery with the Utility.

C. Support pipe every 10 feet during storage and transport.

D. Store pipe in such a way that foreign material does not enter the pipe.

E. Return and deliver excess pipe and appurtenances provided by the Utility to the location directed by the Utility within 30 days of completion.

F. Obtain all material receipts from the Utility and provide a copy to the Construction Manager.

PART 2 - MATERIALS

2.01 PIPING

A. The Utility will provide piping and appurtenances.

2.02 VALVES

A. The Utility will provide valves and valve boxes.

2.03 CONCRETE

- A. Comply with the requirements specified in Section 033000.

2.04 CASING

- A. For casing, use ASTM A252 steel pipe with 3/8-inch minimum wall thickness and galvanize according to ASTM A123. Conform to NACE SP0200. Size casing diameter according to NACE SP0200. Use non-metallic or stainless steel casing spacers, as appropriate for the carrier pipe based on manufacturer recommendations and as approved by the Utility. For stainless steel spacers, use manufacturer-supplied runners, bands, risers, liners, studs and nuts. Ensure that runners are high-pressure molded glass reinforced polyester. Ensure that bands are two-piece 14 gauge, Grade 304 stainless steel with 8-inch minimum width. Ensure that risers are 10 gauge, Grade 304 stainless steel and all nuts, studs, and washers are Grade 304 stainless steel. Ensure that liners are polyvinyl chloride. Provide dogleg casing vents at both ends of the casing according to NACE SP0200. At the ends of casings, use 1/8-inch minimum thickness synthetic rubber end seals with Grade 304 stainless steel banding straps and mastic strips to seal the edges, and rubber link modular seals with stainless steel hardware.

2.05 STEEL PLATE

- A. The Utility will provide 1/2-inch steel plate to be placed over pipe with substandard cover.
- B. For temporary protection of open excavations, use steel plates conforming to ASTM A36.

2.06 BEDDING

- A. Comply with the requirements specified in Section 312300.

2.07 SAND

- A. Comply with the requirements specified in Section 312300.
- B. Coarse Aggregate
 - 1. Use coarse aggregate, No. 57 that complies with the requirements specified in Section 312300.

2.08 GROUT

- A. Nonshrink Grout: Use non-shrink grout of a plastic consistency that conforms to ASTM C1107. Ensure that the grout has a working time of at least 30 minutes from the time the water is added. Match the color of the hardened grout, where visible, to the color of the adjacent hardened concrete. Include 1-day strength tests as part of the performance requirements of ASTM C1107. Ensure that the grout contains no more than 0.05 percent

chlorides or 5.0 percent sulfates by weight. Use Sikagrout 212 by Sika Corporation, CG-86 N.E. Construction Grade Grout by W.R. Meadows, Inc. or Euclid NS Grout by Euclid Chemical Co., grout by SIKA AG, or approved equal.

2.09 CONTROLLED LOW STRENGTH MATERIAL (CLSM)

- A. Comply with the requirements specified in Section 033400.

PART 3 - EXECUTION

3.01 CONSTRUCTION

- A. Provide the Construction Manager and the Utility with a detailed schedule of the work. Notify the Utility in writing at least 15 days before beginning construction of gas facilities. Do not perform work on gas facilities that will result in service interruptions from October 15 to April 15 without approval of the Utility. The Utility may extend this period based on weather conditions and system demand requirements. Perform the work to minimize adverse impact to the Utility's operations.
- B. Provide the Utility with access to the work. Perform all work related to the gas utility facilities in the presence of the Utility's representative.
- C. Determine the location of surface and subsurface structures and utility facilities within the work site. Notify the Construction Manager when excavation is required within 10 feet of any existing utility facility, and submit a plan to the Construction Manager for approval, detailing the proposed methods of excavating around the existing utility facilities, and the proposed methods of protecting and supporting the existing utility facilities. Protect and support utility facilities encountered. Notify the Construction Manager and the Utility three (3) days before crossing any existing utility facilities, so that the Utility may send a representative to the work site at the time of excavation or construction.
- D. Remove and dispose of abandoned pipe, services, valves, boxes, thrust blocks, and appurtenances, unless otherwise directed by the Construction Manager or Utility. Cap or plug pipe that is to be abandoned in a manner that is acceptable to the Utility.
- E. Comply with the requirements specified in Section 312300. Dewater in accordance with the requirements specified in Section 312319. If it is not possible to maintain the trench free of water as determined by the Construction Manager, lower the water to a level approved by the Construction Manager, excavate an additional 6 inches of the material below the bottom of the pipe, and backfill the undercut with compacted coarse aggregate, No. 57. Comply with the requirements specified in Section 021600. Comply with the requirements specified in Sections 315000 and 314116. Do not use excavated pavement, including base and subbase material, as backfill. CLSM may be used as alternate backfill

if approved by the Utility. Do not use CLSM to replace pavement or base course that form the pavement structure.

- F. Excavate trenches only for distances to be installed and backfilled during the same day. If approved by the Construction Manager and the Utility, temporary protection may be used instead of backfilling trenches. Submit shop drawings for temporary protection.
- G. Identify areas where pipe will have less than 3 feet of cover. Provide the Construction Manager with a report of the identified areas in order to obtain the Utility's approval. Use a laser system to control the alignment and grade of the pipe. Place compacted granular bedding. Install pipe so that it is solidly supported by the bedding over its full length except where recesses have been made at joint locations. Ensure that interior of the pipe is kept clean and free of all intrusion by bedding, soil, or other foreign material. Install elbows and associated fittings. Cut standard elbows of 45 or 90 degrees to match the elbow as required by field conditions. Install insulating joints, valves, valve risers, valve boxes, miscellaneous fittings, insulated locating wire, pipeline markers, and test stations. Maintain a 1-foot minimum clearance between utility facilities and structures. Coordinate the installation of gas main with other work, and prevent conflicts and interference with existing facilities and proposed construction.

3.02 WELDING STEEL PIPE

- A. At least 15 days before installing gas mains, submit to the Construction Manager and to the Utility a copy of the welders' Performance Qualification Record showing the welder has been tested and approved by the Utility. Perform welding according to API Standard 1104. Perform welding in a manner that is acceptable to the Utility.
- B. Inspect and clean all pipe and fittings prior to welding. Air scour and wire brush the interior of all steel pipe and fittings the same day they are installed.
- C. Do not tack ground clamps or other devices to the pipe. Repair arc burn damage to the pipe when the depth of the defect is less than 8 percent of the nominal wall thickness by grinding smooth. When the depth of the arc burn physical defect is greater than 8 percent of the nominal wall thickness, remove the defect and the adjacent first weld. Do not perform welding repairs on gouges, scratches, arc burns or other defects of the pipe. The Contractor may make field repairs of gouges and grooves in the parent metal of the pipe by grinding. Do not grind more than 8 percent of the nominal wall thickness of the pipe. Remove dents that contain stress concentrations, such as scratches, gouges, grooves, or arc burns by cutting out the damaged portion of the pipe.
- D. Provide an examination of welds by radiographic (X-ray) inspection by a qualified inspection company approved by the Utility. Deliver the X-ray films and one (1) copy of the radiographic inspection report to the Construction Manager and to the Utility. Apply or repair pipe coating so that pipe coating passes a holiday detector test. Seal field welds and fittings with Raychem Unisleeve or with a double layer of cold applied, 4-inch-wide,

corrosion protective tape as directed by the Utility inspector. Install cathodic protection, including pipe coating, anodes and rectifiers, insulating joints, and test stations. Install the anodes at the lower elevation of the pipe (in or below the water table where possible) and offset the anodes as far as practical from the pipe. Do not place the anodes where other metallic structures such as conduit, cable or pipe is between the main and the anode. Provide temporary blocking to exposed end of gas mains to be abandoned in place using combination beam and column method. Do not backfill around the anodes with bedding. Use excavated material for backfill around the anodes.

3.03 FUSING PLASTIC PIPE

- A. At least 15 days before installing plastic gas mains, submit to the Construction Manager and the Utility the names and training qualifications of personnel intended to perform fusing for approval. Ensure that personnel fusing and inspecting butt fusion joints are certified according to 49 CFR 192. Before fusing plastic pipe, obtain the approval of the Utility for the heat fusion equipment. Fabricate steel to plastic transition fittings using an electric arc welder. Inspect and clean all pipe and fittings prior to welding.

3.04 THRUST RESTRAINTS AND BELL JOINT ENCAPSULATION

- A. Install thrust restraints and bell joint encapsulation devices as directed by the Utility before excavating other areas around the main. The number of thrust restraints and bell joint encapsulations is dependent upon field conditions and the location of the tie-in and live gas excavations.

3.05 HOT TAP PREPARATION

- A. When hot taps are performed by the Utility, in the presence of the Utility's representative, weld a spherical tee, three-way tee, line stop fitting or other fitting on the existing steel main, or install a split sleeve collar, line stop fitting or other fitting on the existing cast iron main.

3.06 BACKFILL

- A. Symmetrically backfill on each side of the pipe using Dense Graded Aggregate (DGA) in lifts not exceeding 6 inches thick, loose measurement. When the height of 1 foot above the pipe is achieved, place caution tape. Backfill the remainder of the trench with suitable excavated material that is free from rock larger than 2 inches in diameter in lifts not exceeding 6 inches thick, loose measurement. For plastic mains with less than 2 feet of cover, enclose with steel pipe or protect with a steel plate. If the pipe is in an area not subject to vehicular traffic, steel plate is not required. Comply with the requirements specified in Section 312300.
- B. Backfill and restore the pavement structure and match the surrounding condition before opening roads to traffic. For trenches not in sidewalk or roadways, do not leave trenches

open overnight unless protected with caution fence and approved by the Construction Manager.

3.07 LINE STOP AND TIE-IN ASSISTANCE

- A. Excavate pits as required to provide access to the Utility for line stops, flow stops, bypass insertions, bagging and venting, hot taps, thrust restraints, purging, and tie-ins. Protect using temporary fencing or steel plates as directed. Maintain the excavation until the Utility has completed its work. Construct a concrete support pad under the pipe at locations requiring a line stop before the arrival of the Utility's line stop crew. Assist the Utility in handling the pipe by providing sufficient labor and equipment.

3.08 TIE-IN AND GAS OUT

- A. Perform cutouts and tie-ins at both ends of the pipe simultaneously. The Utility will purge and cut the pipeline. Once started, continue the work of tie-ins until completed. Keep tie-in excavations open or plated as required until the Utility has completed its work. As necessary, modify standard tie-in pieces to fit connection requirements.

3.09 AIR-PRESSURE TEST

- A. Perform an air-pressure test on new pipeline including tie-in pieces under the direction and supervision of the Utility. Perform the test according to the pressures and durations directed by the Utility. Provide all equipment necessary for the test. Locate and repair leaks in a manner that is approved by the Utility. Pig steel gas mains using a scraper barrel pig or a poly pig when testing plastic mains. Ensure that the pig is in a like new condition that is acceptable to the Utility. If using caps or expansion joints, anchor the pipe in a manner that is acceptable to the Utility to prevent any movement during the test. Retest after making repairs.

3.10 SERVICE CONNECTION

- A. Perform work associated with the transfer of service including the excavation of one tie-in hole for direct burial and transfer installations and two tie-in holes for insert installations. Submit to the Construction Manager and the Utility the names and training qualifications of personnel intended to install fused or mechanical connections for approval.
- B. Turn off the gas at the service tee using pressure control equipment before cutting the existing service pipe. Disconnect the service pipe inside the building before the meter. Support the meter to avoid stressing the building piping. Install services either by inserting plastic tubing in the existing service or by directly burying plastic tubing or pipe.
- C. Installing Services with Direct Burial of Plastic Pipe: Install the direct burial plastic service including location wire from the main to the building, fuse the pipe, and assist the Utility to tie the connection into the gas main. Backfill above the pipe with sand in lifts

not exceeding 6 inches thick, loose measurement. When the height of backfill reaches 2 feet above the service connection, backfill the remainder of the trench with suitable excavated material that is free from rock larger than 2 inches in diameter in lifts not exceeding 6 inches thick, loose measurement. Comply with the requirements specified in Section 312300. Install a curb shut-off valve and install a meter shut-off valve at the head of the service. Seal the hole in the foundation wall and surround the service pipe with cement or grout. Electrofuse or weld the self-tapping tee to the main and connect it to the service using Electrofuse or mechanical fittings.

- D. Installing Services by Plastic Tubing Insertion: Excavate and remove any curb shut-off, offset, swing or service drip that may impede the insertion of the plastic pipe. Ream the existing service from the building to the main. After reaming, air-blow the existing service from the building to the main. Insert the plastic tubing from the main to the building. Install a curb shut-off valve and install meter shut-off valve at the head of the service. Leave the meter shut off valve open with the plug installed. Electrofuse or weld the self-tapping tee to the new main and connect it to the new plastic service using Electrofuse or mechanical fittings.
- E. Pressure test the service as required and soap test all fuses and mechanical connections. Perform pressure and soap tests in the presence of the Utility inspector. Release the pressure, tap a self-tapping tee, and gas out service through the hose from the meter shut off to the outside of the building until a gas reading of greater than 95 percent is obtained using a combustible gas indicator. Install a tee cap and soap test the cap.

3.11 CASING

- A. Where indicated on the drawings or directed by the Construction Manager, install solid or split casing; install split casing to protect existing gas pipe to remain. Construct according to NACE SP0200. Install spacers and end seals with casings. Use spacers that center the pipe in the casing unless special spacers are required at the end seal based on manufacturer recommendations. Locate and space spacers according to the manufacturer's recommendations, at a minimum: within one foot of each side of joints in the carrier pipe; intermediately at maximum 8-foot spacing; within one foot of each end of the casing; and, an additional spacer 5 feet from each end of the casing. If manufactured split casing is not used, cut casing for split casing to prevent warping in the fabrication shop. No field splitting will be allowed. Bevel welding surfaces. Weld joints in a minimum of two (2) passes. Weld the entire circumference and length of casing. Weld according to API Standard 1104. Construct casing to achieve a permanently leak-proof system. For steel gas mains, install test leads on both the carrier pipe and the casing at each end of the casing and route to test stations at each end of the casing. After backfill, test to ensure that the carrier pipe and casing are not electrically shorted. Repair galvanized coating according to ASTM A780.

3.12 RESET GAS VALVE BOXES

- A. Adjust the height of the existing valve box so that it is set flush with the proposed grade without disturbing the existing valve.

3.13 AS-BUILT

- A. Within five (5) days of completion of each pipe run, submit to the Construction Manager and to the Utility as-built drawings in a CADD format acceptable to the Utility. Include as-built locations of piping, valves, connections, thrust restraints, invert elevations, and depth of cover. Identify and describe unexpected variations in subsoil conditions or discovery of uncharted utility facilities.

3.14 PROTECTION

- A. Protect gas utility facilities from damage throughout storage, installation, testing, and final acceptance.

3.15 CONTRACT CLOSEOUT

- A. Provide in accordance with Section 017700.

END OF SECTION 335000

NO TEXT ON THIS PAGE

SECTION 337000 - ELECTRIC UTILITIES

PART 1 - GENERAL

1.01 SUMMARY

- A. This Section includes materials, installation, and testing of ducts, handholes, pull boxes, manholes, vaults, and related materials for electric utility facilities. The Utility will perform all cable work.
- B. Perform work according to PSE&G's General Specification. Only a pre-qualified contractor approved by the Utility may perform work on the utility. Pre-qualified contractors include:

J FLETCHER CREAMER & SONS. INC.

101 East Broadway
Hackensack, New Jersey 07601
Jorge Pires
Telephone 201-954-7366
Ted Palowada
Telephone 201-481-7018
tpaliwoda@jfcson.com

HENKELS & MCCOY INC.

Elbow Lane
PO Box 218
Burlington, New Jersey 08016
Telephone 609-387-9000
Ray Hill or Jim Rudolph
jrudolph@henkels.com

KEMSCO CONSTRUCTION INC.

PO Box 10019
139 Harper Street
Newark, New Jersey 07101
Ralph Serpe
Telephone 973-733-2255
Tony Perichio
Telephone 973-418-7895
kemscoinc@aol.com

FERREIRA CONSTRUCTION

31 Tannery Road

Branchburg, New Jersey 08876
Telephone 908 534 8655 x 274
Brian Delpome
BDelpome@ferreiraconstruction.com

ROMAN E & G CORP.
14 Ogden Street
Newark, New Jersey 07104
Joe Bellott
Telephone 973-766-5369
Michael Lamorgese
Telephone 973-482-2501
romaneandg@optimum.net

DANELLA CONSTRUCTION CORPORATION
2290 Butler Pike
Plymouth Meeting, Pennsylvania 19462
Richard Neas
Telephone 610-397-1193

BOND BROTHERS, INC.
145 Spring Street
Everett, Massachusetts 02149
Telephone 617-387-3400
Sean McAullife
Telephone 860-349-8880 Work
Telephone 617-212-6858 Cell
smcauliffe@bondbrothers.com

1.02 PAYMENT

- A. No separate payment shall be made for performing any Work required under this Section. All costs for Work shown on the plans and required by this Section shall be included in the applicable lump sum(s), unit price(s), or allowance(s) as set forth in Section 012901.
- B. Electric utilities or services that require relocation not shown on the plans or directed by the Construction Manager shall be paid for under the Utility Allowance as set forth in Section 012901.

1.03 REFERENCES

- A. PSE&G General Specification No. 2016-5065 for Trench, Manhole, and Conduit Installation, current edition.

B. ASTM International (ASTM):

1. A36: Standard Specification for Carbon Structural Steel.
2. A123: Standard Specification for Zinc (Hot-Dip Galvanized) Coatings on Iron and Steel Products.
3. A252: Standard Specification for Welded and Seamless Steel Pipe Piles.
4. A780: Standard Practice for Repair of Damaged and Uncoated Areas of Hot-Dip Galvanized Coatings.
5. C881: Standard Specification for Epoxy-Resin-Base Bonding Systems for Concrete.
6. C1107: Standard Specification for Packaged Dry, Hydraulic-Cement Grout (Nonshrink).
7. D41: Standard Specification for Asphalt Primer Used in Roofing, Dampproofing, and Waterproofing.
8. D449: Standard Specification for Asphalt Used in Dampproofing and Waterproofing.

C. American Welding Society (AWS):

1. D1.1: Structural Welding Code - Steel.

1.04 RELATED SECTIONS

- A. General Conditions Article 4.7 – Shop Drawings and Other Submittals.
- B. Section 012901 – Measurement and Payment.
- C. Section 014300 - Quality Requirements.
- D. Section 016100 - Control of Materials.
- E. Section 017700 - Contract Closeout.
- F. Section 021600 - Excess Clean Fill, Contaminated Soil, and Groundwater Management and Disposal.
- G. Section 031000 - Concrete Formwork.
- H. Section 031500 - Concrete Joints and Accessories.

- I. Section 032100 - Reinforcement Bars.
- J. Section 033000 - Cast-in-Place Concrete.
- K. Section 033400 – Controlled Low Strength Materials
- L. Section 312300 - Excavation and Fill.
- M. Section 312319 - Dewatering.
- N. Section 315000 - Excavation Support Systems.
- O. Section 333915 - Manholes and Structures.

1.05 SUBMITTALS

- A. Submit the following shop drawings in accordance with General Conditions Article 4.7.
 - 1. Nonshrink grout.
 - 2. Epoxy grout.
 - 3. Interstitial grout.
 - 4. Pull rope.
 - 5. Epoxy bedding compound.
 - 6. CLSM.
 - 7. Aggregates and bedding.
 - 8. Warning tape.
 - 9. Casing, spacers and sealers.
 - 10. Certificate of compliance for casing pipe.
 - 11. Temporary protection for excavations.
 - 12. All temporary works.

1.06 DEFINITIONS

- A. Utility: The company, agency, or other entity that provides electric service.
- B. Vault: An enclosure above or below ground that is large enough for personnel to enter and is used for the purpose of installing, operating, or maintaining equipment or cabling.

- C. Manhole: A subsurface enclosure that is large enough for personnel to enter and that is used for the purpose of installing, operating, and maintaining equipment.
- D. Pull Box: A subsurface enclosure that has a bottom and is used with underground lines, into which personnel can reach but not enter, for the purpose of installing, operating, or maintaining equipment, cabling, or both.
- E. Handhole: An access opening, provided in equipment or a below-the-surface enclosure without a bottom used with underground lines, into which personnel can reach but not enter, for the purpose of installing, operating, or maintaining equipment, cabling, or both.
- F. Duct: The general term for an electrical conduit or raceway, either metallic or nonmetallic, for use underground.
- G. Duct Bank: A group of two (2) or more ducts in a continuous run between two (2) points.
- H. PSE&G's General Specification: PSE&G General Specification No. 2016-5065 for Trench, Manhole, and Conduit Installation.

1.07 QUALITY CONTROL

- A. Comply with the requirements specified in Section 014300.
- B. Follow the accepted standards of ANSI, NEMA, IEEE, ASME, NBFU, ASHRAE, and ASTM for materials not provided by the Utility.
- C. Follow the accepted standards of ANSI, NEMA, IEEE, ASME, NBFU, ASHRAE, and ASTM for construction operations not specified in the Contract.

1.08 DELIVERY, STORAGE, AND HANDLING

- A. Comply with the requirements specified in Section 016100.
- B. Coordinate pick up or delivery of materials. Deliver ducts to site and store with ends capped. Store ducts with supports to prevent bending, warping, and deforming.

PART 2 - MATERIALS

2.01 CONCRETE MATERIALS

- A. Comply with Section 031000 for forming of concrete, Section 032100 for reinforcement for cast-in-place concrete, Section 033000 for cast-in-place concrete, and Section 031500 for joints and accessories.

2.02 HANDHOLES AND PULL BOXES

- A. Precast: The Utility will provide precast handholes and pull boxes.
- B. Cast-in-Place: Comply with Section 033000, Class A. Paint the outside surface with two (2) coats of asphalt cement waterproofing according to the manufacturer's recommendations. Use asphalt waterproofing conforming to ASTM D449, Type I. Use a primer conforming to ASTM D41.

2.03 CONCRETE MANHOLES AND VAULTS

- A. Precast: The Utility will provide precast concrete manholes and vaults.
- B. Cast-in-Place: Comply with Section 033000, Class A. Paint the outside surface with two (2) coats of asphalt cement waterproofing according to the manufacturer's recommendations. Use asphalt waterproofing conforming to ASTM D449, Type I. Use a primer conforming to ASTM D41.

2.04 CONCRETE ENCASEMENT

- A. Comply with Section 033000, Class C.

2.05 CONDUIT

- A. The Utility will provide conduit and appurtenances, including spacers and sealant. The Utility will provide risers and vertical bends for risers. Use only prefabricated bends.

2.06 PULL ROPE

- A. Use polypropylene rope, minimum 1/2-inch diameter except in 2-inch street light conduit, use 3/16-inch rope.

2.07 CASING

- A. For casing, use ASTM A252 steel pipe with 3/8-inch minimum wall thickness and galvanize according to ASTM A123. Size the casing to provide at least 2-inch minimum clearance between the casing and all conduit/carrier pipe, joints and couplings. Use non-metallic or stainless steel casing spacers as appropriate for the carrier pipe/conduit based on manufacturer recommendations and as approved by the Utility. For stainless steel spacers, use manufacturer-supplied runners, bands, risers, liners, studs and nuts. Ensure that runners are high-pressure molded glass reinforced polyester and bands are two-piece 14 gauge, Grade 304 stainless steel with 8-inch minimum width. Ensure that risers are 10 gauge, Grade 304 stainless steel and all nuts, studs, and washers are Grade 304 stainless steel. Ensure that liners are polyvinyl chloride. At the ends of casings, use 1/8-inch minimum thickness synthetic rubber end seals with Grade 304 stainless steel banding

straps and mastic strips to seal the edges. In addition, use rubber link modular seals with stainless steel hardware at single carrier pipes/conduits.

2.08 STEEL PLATE

- A. The Utility will provide ½-inch steel plate to be placed over ducts with substandard cover.
- B. For temporary protection of open excavations, use steel plates conforming to ASTM A36.

2.09 COARSE AGGREGATE

- A. Use coarse aggregate, No. 57 that complies with Section 312300.

2.10 MORTAR

- A. Mix one (1) part cement to two (2) parts fine aggregate. Add water to form the proper consistency. Do not temper mortar or use mortar after it has begun to set.

2.11 GROUT

- A. Nonshrink Grout: Use nonshrink grout of a plastic consistency that conforms to ASTM C1107. Ensure that the grout has a working time of at least 30 minutes from the time the water is added. Match the color of the hardened grout, where visible, to the color of the adjacent hardened concrete. Include 1-day strength tests as part of the performance requirements of ASTM C1107. Ensure that the grout contains no more than 0.05 percent chlorides or 5.0 percent sulfates by weight. Use Sikagrout 212 by Sika Corporation, CG-86 N.E. Construction Grade Grout by W.R. Meadows, Inc. or Euclid NS Grout by Euclid Chemical Co., grout by SIKA AG, or approved equal.
- B. Epoxy Grout: Use epoxy grout that conforms to the requirements of ASTM C881, Type 1, Grade 3, Class B or C. Use Dural 452 or HS Gel by Euclid Chemical Co., HTE 50, HIT-RE 100, HIT-RE500v3, HIT-RE 10 by Hilti North America, Sikadur Anchorfix 3001, Sikadur Anchorfix 500, or Sikadur Anchorfix-2 by Sika Corporation, or approved equal.

2.12 EPOXY BONDING COMPOUND

- A. Comply with Section 033000.

2.13 FLUIDIZED THERMAL BACKFILL

- A. The Utility will provide fluidized thermal backfill.

2.14 CONTROLLED LOW STRENGTH MATERIAL (CLSM)

- A. Comply with Section 033400.

2.15 BEDDING

- A. Comply with Section 312300 for granular bedding.

2.16 EPOXY BEDDING COMPOUND

- A. Use a 2-part, non-sag gel, rapid-setting epoxy adhesive conforming to ASTM C881, Type 4, Grade 3, Class B or C. Use the epoxy in an ambient temperature range of 40 to 100 degrees F.

2.17 WARNING TAPE

- A. A 6-inch-wide magnetically detectable warning tape with red protective polyethylene jacket resistant to alkalis, acids, and other destructive elements continuously imprinted "CAUTION--ELECTRICAL CONDUIT BELOW" unless otherwise directed by the Utility.

2.18 CASTINGS

- A. The Utility will provide frames and covers.

PART 3 - EXECUTION

3.01 EXCAVATION AND BACKFILL

- A. Provide the Construction Manager and the Utility with a detailed schedule of the work. Notify the Utility in writing at least 15 days before beginning construction of utility facilities. Do not perform work on electric facilities that will result in service interruptions from May 1 to October 1 or when the temperature is in excess of 85 degrees, without approval of the Utility. The Utility may extend this period based on weather conditions and system demand requirements. Perform the work to minimize adverse impact to the Utility's operations.
- B. Perform work in a manner that is acceptable to the Utility, and in coordination with the Construction Manager. Provide the Utility with access to the work. Perform all work related to the utility facilities in the presence of the Utility's representative.
- C. Determine the location of surface and subsurface structures and utility facilities within the work site. Notify the Construction Manager when excavation is required within 10 feet of any existing utility facility and submit a plan to the Construction Manager for approval, detailing the proposed methods of excavating around the existing utility facilities, and the proposed methods of protecting and supporting the existing utility facilities. Protect and support utility facilities encountered. Notify the Construction Manager and the Utility three (3) days before crossing any existing utility facilities, so

that the Utility may send a representative to the work site at the time of excavation or construction.

- D. Remove and dispose of abandoned ducts, services, cable, boxes, manholes, vaults and appurtenances in direct conflict with the work or as directed by the Utility unless otherwise directed by the Construction Manager or Utility. Cap or plug ducts that are to be abandoned in a manner that is acceptable to the Utility.
- E. Comply with the requirements specified in Section 312300. Dewater in accordance with the requirements specified in Section 312319. If it is not possible to maintain the trench free of water as determined by the Construction Manager, lower the water to a level approved by the Construction Manager, excavate an additional 6 inches of the material below the bottom of the pipe, and backfill the undercut with compacted coarse aggregate, No. 57. Comply with the requirements specified in Section 021600. Comply with the requirements specified in Section 315000. Do not use excavated pavement, including base and subbase material, as backfill. CLSM may be used as alternate backfill as specified in Section 312300 with the approval of the Utility and the Construction Manager. Restore disturbed areas to original conditions, the conditions specified in the contract, or as directed by the Construction Manager.
- F. Backfill and restore the pavement structure and match the surrounding condition before opening roads to traffic. For trenches not in sidewalk or roadways, do not leave trenches open overnight unless protected with caution fence and approved by the Construction Manager.
- G. Trenches may be backfilled immediately after placing concrete encasement, provided the concrete is covered with heavy paper. Backfill according to PSE&G's General Specification.

3.02 DUCT LAYOUT

- A. Limit the maximum change of direction in horizontal plane to a minimum radius of 12'-6".
- B. Where other utility systems are encountered or are being installed, maintain a 12-inch minimum separation between utility facility and other system. Maintain a 12-inch minimum separation between utility facility and structures.
- C. Do not place ducts over valves or couplings in other piping systems. Do not construct conduit directly over or under and parallel to other facilities or structures.
- D. Slope: Pitch ducts to drain toward vaults, manholes, handholes, and pull boxes and away from buildings and equipment. Minimum slope shall be 4 inches in 100 feet. Ducts may slope from a high point in the run to drain in both directions.

- E. Minimum Cover: 30-inch minimum cover over top of concrete for concrete-encased ducts. At locations with less than 30-inch cover, install a 1/2-inch steel plate for protection. Do not construct ducts with less than 12-inch cover. Do not install conduits with more than 42 inches of cover unless approved by the Utility in writing.

3.03 DUCT INSTALLATION

- A. Use Utility-provided conduit spacers to provide 1 1/2-inch minimum separation between conduits. Locate spacers not less than 4 feet center-to-center along entire length of ducts. Secure ducts and spacers with polypropylene banding to prevent movement during concrete placement.
- B. Place duct couplings side-by-side horizontally but staggered at least 6 inches vertically.
- C. Make joints in accordance with the Utility's and manufacturer's recommendations.
- D. Construct conduit with a minimum of bends.
- E. Excavate trenches only for distances to be installed and backfilled during the same day. If approved by the Construction Manager and the Utility, temporary protection may be used instead of backfilling trenches. Submit shop drawings for temporary protection.
- F. Install risers as directed by the Utility.

3.04 CONCRETE ENCASUREMENT OF CONDUITS

- A. Encase duct in Class C concrete. Make duct encasement monolithic. Use hand-held vibrators or as directed by the Utility to consolidate concrete around conduits.
- B. Maintain 1 1/2-inch minimum separation between conduits and 3-inch minimum concrete encasement around ducts. Do not exceed the indicated outside dimensions of the duct by more than 1 inch vertically or 4 inches horizontally.
- C. Pour each encasement envelope between manholes or other terminations in one continuous operation. Where more than one pour is necessary, terminate each pour in a vertical plane and install 3/4-inch reinforcing rod dowels extending 18 inches into the concrete on each side of the joint near the corners of the envelope.

3.05 IDENTIFICATION

- A. Bury warning tape approximately 12 inches above all conduit banks.
- B. Align tapes and protective plates within 3 inches of the centerline of the conduit bank.

3.06 HANDHOLES AND PULL BOXES

- A. Install cast-in-place concrete handholes and pull boxes unless otherwise directed by the Utility.
- B. Provide a 6-inch gravel base for open-bottom handholes.

3.07 MANHOLES AND VAULTS

- A. Do not enter manholes or vaults without first verifying the adequacy of the oxygen supply and the absence of gas.
- B. Comply with PSE&G's General Specification for the excavation limits for manholes. Provide a base of 6 inches of compacted coarse aggregate, No. 57 for leveling.
- C. The precast supplier will deliver precast manholes and vaults. The supplier will install precast manholes and vaults up to 6'×17'-6" and 3-way manholes. Ensure access to the site. Use a crane to install precast manholes and vaults larger than 6'×17'-6", 4-way manholes and 7'×19' transformer manholes. If the lower section is not installed level to the Utility's satisfaction, remove it, level the coarse aggregate base and reinstall. Notify the Utility at least 48 hours in advance of the anticipated installation date. Do not schedule installation until receiving notification from the Utility that the manhole or vault is prepared for delivery.
- D. Install cast-in-place manholes and vaults and cast-in-place bottoms per Sections 033000 and 333915.
- E. Backfill according to PSE&G's General Specification and Section 312300.

3.08 CASTINGS

- A. Set casting in mortar beds or anchor castings to the masonry before finishing adjoining work with the same final elevation. Ensure that mortar attains a strength of 2500 pounds per square inch before opening to traffic. Set the manhole cover or inlet grate on the casting. If the manhole cover or inlet grate is loose or wobbles, grind to obtain a tight fit.

3.09 STREET LIGHTING

- A. Use cast-in-place concrete for foundations. Mandrel and rope conduit from the foundation to the manhole. Furnish and erect protective barricades with flashers until poles are erected by the Utility.

3.10 CASING

- A. Where indicated on the drawings or directed by the Construction Manager, install solid or split casing; install split casing to protect existing conduit or pipe. Install spacers and

end seals with casings. Locate and space spacers according to the manufacturer's recommendations, at a minimum: within one foot of each side of joints in the carrier pipe; intermediately at maximum 8-foot spacing; within one foot of each end of the casing; and, an additional spacer 5 feet from each end of the casing. Cut casing for split casing to prevent warping in the fabrication shop. No field splitting will be allowed. Bevel welding surfaces. Weld joints in a minimum of two (2) passes. Weld the entire circumference and length of casing. Weld according to AWS D1.1. Construct casing to achieve a permanently leak-proof system. Fill casings around transmission pipes with fluidized thermal backfill after welding joints. Repair galvanized coating according to ASTM A780.

3.11 ACCEPTANCE TEST

- A. Pull a bristle brush of a diameter approximately 1/4 inch greater than the duct inside diameter through each duct to remove debris. If directed by the Utility or the Construction Manager, clean existing vacant ducts.
- B. Pull a mandrel of a diameter approximately 1/4 inch less than the duct inside diameter and at least 12 inches long, through each duct. If required, rod existing vacant ducts.
- C. Install pull rope in each conduit. Install measuring tape in lieu of pull rope in single duct installations and in one (1) duct of a multiple duct bank.
- D. Repair or replace any portion of the duct through which the mandrel and brush will not pass at the Contractor's expense.

3.12 CONTRACT CLOSEOUT

- A. Provide in accordance with Section 017700.

END OF SECTION 337000

SECTION 338000 TELEPHONE UTILITIES

PART 1 - GENERAL

1.01 SUMMARY

- A. This Section includes materials, installation, and testing of ducts, handholes, pull boxes, manholes, and related materials for communication utility facilities. The Utility will perform all cable work. The Utility will not order cable until the work specified herein is complete and the Utility receives as-built drawings.
- B. Perform work as specified herein, and according to the Verizon Conduit Plans, which Verizon will provide, and the Verizon Conduit Specifications.
- C. Notify the Utility representative in writing at least 72 hours before beginning Verizon work to arrange a conduit inspector. Notify the Utility representative in writing no later than Wednesday of the previous week for scheduled night work. Perform all work related to the Utility in the presence of the Utility inspector.
- D. Only a pre-qualified contractor approved by the Utility may perform work on the utility. Pre-qualified contractors include:

CASPER COLOSIMO & SON, INC.
5170 Campbells Run Road
Pittsburgh, Pennsylvania 15205
Leon Casilli
Telephone: 412-787-1266
leonc@caspercol.com

DYCOM INDUSTRIES, INC.
11770 U.S. Highway 1, Suite 101
Palm Beach Gardens, Florida 33408
Tim Estes
Telephone: 561-627-7171
timestes@dycominc.com

LAMBERTS CABLE SPLICING CO. LLC
2521 South Wesleyan Boulevard
Rocky Mountain, North Carolina 27803
Tommy Lambert
Telephone: 252-442-9777 x 223
tlambert@lambertcable.com

COMMUNICATIONS CONSTRUCTION GROUP, LLC
1060 Andrew Drive, Suite 130
West Chester, Pennsylvania 19380
John Dowd
Telephone: 800-822-3345
jdowd@ccgcatv.com

PARKSIDE UTILITY CONSTRUCTION, LLC
219 Ruth Road
Harleysville, Pennsylvania 19438
William D. Rowe III
Telephone: 215-513-9500 x 302
bill.rowe@parksideutil.com

FISHEL COMPANY/TEAM FISHEL
1366 Dublin Road
Columbus, Ohio 43215
Randy Blair
Telephone: 800-829-4530
orblair@teamfishel.com

GENERAL ASPHALT PAVING COMPANY, INC.
9301 Krewstown Road
Philadelphia, Pennsylvania 19115
Austin Meehan
Telephone: 215-677-2626
aameehan@johnmeehanandson.com

HENKELS & MCCOY, INC.
P.O. Box 1742
York, Pennsylvania 17406
John Donmoyer
Telephone: 717-266-5641
jdonmoyer@henkels.com

J. FLETCHER CREAMER & SON, INC.
101 East Broadway
Hackensack, New Jersey 07601
Dan Urban
Telephone: 908-986-5729
urban@jfcson.com

KLINE CONSTRUCTION COMPANY, INC.
240 Waveland Avenue
Absecon Highlands, New Jersey 08205

Kathie Kline
Telephone: 609-652-3000
kmkline@klineconstruction.net

MASTEC NORTH AMERICA, INC.
110 Repetto Avenue
Egg Harbor Township, New Jersey 08234
Rob Lamey
Telephone: 609-645-2409
rob.lamey@mastec.com

NX UTILITIES LLC
2587 Industry Lane
West Norriton, Pennsylvania 19403
Scott Lochhead
Telephone: 561-829-7127
slochhead@nxutilities.com

UTILITY LINE SERVICES, INC.
1302 Conshohocken Road
Conshohocken, Pennsylvania 19428
Austin Meehan
Telephone: 610-239-0900 x 100
ameehan@ulscorp.com

WECO CONSTRUCTION, INC.
3031 Ocean Heights Avenue
Egg Harbor Township, New Jersey 08234
Donna Delaney
Telephone: 609-927-6661
dld@arhenry.com

1.02 PAYMENT

- A. No separate payment shall be made for performing any Work required under this Section. All costs for Work shown on the plans and required by this Section shall be included in the applicable lump sum(s), unit price(s), or allowance(s) as set forth in Section 012901.
- B. Telephone utilities or services that require relocation not shown on the plans or directed by the Construction Manager shall be paid for under the Utility Allowance as set forth in Section 012901.

1.03 REFERENCES

- A. General Notes, Verizon Conduit Specifications.
- B. Verizon Conduit Plans.
- C. Bell System Practices, AT&T Company Standards.
- D. ASTM International (ASTM):
 - 1. A36: Standard Specification for Carbon Structural Steel.
 - 2. A123: Standard Specification for Zinc (Hot-Dip Galvanized) Coatings on Iron and Steel Products.
 - 3. A252: Standard Specification for Welded and Seamless Steel Pipe Piles.
 - 4. A780: Standard Practice for Repair of Damaged and Uncoated Areas of Hot-Dip Galvanized Coatings.
 - 5. C881: Standard Specification for Epoxy-Resin-Base Bonding Systems for Concrete.
 - 6. C1107: Standard Specification for Packaged Dry, Hydraulic-Cement Grout (Nonshrink).
 - 7. D1785: Standard Specification for Poly(Vinyl Chloride) (PVC) Plastic Pipe, Schedules 40, 80, and 120.
- E. American Welding Society (AWS):
 - 1. D1.1: Structural Welding Code - Steel.
- F. National Electrical Manufacturers Association (NEMA):
 - 1. TC-10: PVC Plastic Communications Duct and Fittings for Underground Installation.
- G. Bellcore CA08546
- H. Bell System Practices, Section 922-520-100, Issue 7.

1.04 RELATED SECTIONS

- A. General Conditions Article 4.7 – Shop Drawings and Other Submittals.
- B. Section 012901 – Measurement and Payment.

- C. Section 014300 - Quality Requirements.
- D. Section 016100 - Control of Materials.
- E. Section 017700 - Contract Closeout
- F. Section 021600 - Excess Clean Fill, Contaminated Soil, and Groundwater Management and Disposal.
- G. Section 023219 – Subsurface Utility Locating (Potholing).
- H. Section 033000 – Cast-in-Place Concrete.
- I. Section 033400 – Controlled Low Strength Material (CLSM)
- J. Section 312300 - Excavation and Fill.
- K. Section 312319 - Dewatering.
- L. Section 315000 - Excavation Support Systems.
- M. Section 333915 - Manholes and Structures.

1.05 SUBMITTALS

- A. Submit the following shop drawings in accordance with General Conditions Article 4.7.
 - 1. Manholes
 - 2. Racks
 - 3. Ladders
 - 4. Concrete for encasement
 - 5. Granular encasement
 - 6. Conduit, risers and appurtenances
 - 7. Non shrink grout
 - 8. Pull rope
 - 9. Measuring tape
 - 10. Epoxy bonding compound
 - 11. Epoxy bedding compound

12. Aggregates
13. Warning tape
14. Certificate of compliance for casing pipe
15. Temporary protection for excavations
16. All temporary works

1.06 DEFINITIONS

- A. Utility: The company, agency, or other entity that provides service.
- B. Manhole: A subsurface enclosure that is large enough for personnel to enter and that is used for the purpose of installing, operating, and maintaining equipment.
- C. Pull box: A subsurface enclosure that has a bottom and is used with underground lines, into which personnel can reach but not enter, for the purpose of installing, operating, or maintaining equipment, cabling, or both.
- D. Handhole: An access opening, provided in equipment or a below-the-surface enclosure without a bottom used with underground lines, into which personnel can reach but not enter, for the purpose of installing, operating, or maintaining equipment, cabling, or both.
- E. Duct: The general term for a conduit for use underground.
- F. Duct bank: A group of two or more ducts in a continuous run between two points.

1.07 DELIVERY, STORAGE, AND HANDLING

- A. Store ducts with ends capped. Store ducts with supports to prevent bending, warping, and deforming.

PART 2 - MATERIALS

2.01 GENERAL

- A. If not specified herein, use materials according to Verizon Conduit Specifications, Bell System Practices, AT&T Standards. Submit material shop drawings to the Utility for approval.

2.02 CONCRETE MATERIALS

- A. Comply with Section 033000.

2.03 MANHOLES

- A. Use reinforced precast concrete manholes constructed according to Verizon Specifications and supplied by A.C. Miller (Telephone: 610-948-4600) or Old Castle (Telephone: 888-965-3227). Use manholes that are provided with bonding ribbons. Use the manhole size shown on the Verizon Conduit Plans. The supplier will deliver manholes with a boom truck that can be used for installation. Comply with Section 333915.

2.04 HANDHOLES AND PULL BOXES

- A. The Utility will provide handholes and pull boxes.

2.05 RACKS

- A. Use galvanized steel channel-type racks with 47 holes and an overall length of 70 ¼ inches and with mount-through hook holes. Channel dimensions 1 ½" × 9/16" × 3/16"; rack weight 7.25 pounds each. Use part number 400836268 as manufactured by Hubbell Power Systems Inc, rack manufactured by Graybar Co., rack by Bauer Ladder, Inc., or approved equal.

2.06 LADDERS

- A. Use part number 1-3600-(length) S as manufactured by Inwesco Incorporated, Pipeline Products Inc., Bauer Ladder, Inc., or approved equal, where the ladder length is 1'-6" longer than the manhole interior height based on a 2-foot chimney and excluding the hook. For longer chimneys, adjust the ladder length accordingly. One ladder per manhole.

2.07 ENCASEMENT

- A. For concrete encasement, comply with Section 033000, but ensure that the 28-day compressive strength is 1,500 pounds per square inch.
- B. For granular encasement, use sand or granular bedding that complies with Section 312300.

2.08 CONDUIT

- A. Use 4-inch diameter Telephone Duct, Type C and fittings conforming to NEMA Standard TC-10 and Bellcore CA08546, or 4-inch diameter Schedule 40 PVC pipe conforming to ASTM D1785. Provide vertical bends conforming to ASTM D1785, Schedule 40. Provide white conduit and fittings.

- B. Ensure that split duct is split plastic duct typically used to make Verizon repairs and is approved by the Utility. Use split duct with tongue and groove joints. Use plastic reinforcing strips for split duct.
- C. Use plastic internal joining couplings.
- D. Use pole straps for risers as manufactured by Highland Valley Supply, Inc., Grainger Industrial Supply, Inc. Best Materials, Inc., or approved equal.

2.09 CASING

- A. For casing, use ASTM A252 steel pipe with 3/8-inch minimum wall thickness and galvanize according to ASTM A123. Size the casing based on the size and number of conduits in the duct bank. At the ends of casings, install end seals. Use 1/8-inch minimum thickness synthetic rubber end seals with Grade 304 stainless steel banding straps and mastic strips to seal the edges. If required by the Utility, also use rubber link modular seals with stainless steel hardware.

2.10 STEEL PLATE

- A. For temporary protection of open excavations, use steel plates conforming to ASTM A36.

2.11 COARSE AGGREGATE

- A. Use coarse aggregate, No. 57 that complies with Section 312300.

2.12 MORTAR

- A. Mix one (1) part cement to two (2) parts fine aggregate. Add water to form the proper consistency. Do not temper mortar or use mortar after it has begun to set.

2.13 GROUT

- A. Non shrink Grout: Use non shrink grout of a plastic consistency that conforms to ASTM C1107. Ensure that the grout has a working time of at least 30 minutes from the time the water is added. Match the color of the hardened grout, where visible, to the color of the adjacent hardened concrete. Include 1-day strength tests as part of the performance requirements of ASTM C1107. Ensure that the grout contains no more than 0.05 percent chlorides or 5.0 percent sulfates by weight. Use Sikagrout 212 by Sika Corporation, CG-86 N.E. Construction Grade Grout by W.R. Meadows, Inc. or Euclid NS Grout by Euclid Chemical Co., or approved equal.

2.14 EPOXY BONDING COMPOUND

- A. Comply with Section 033000.

2.15 CONTROLLED LOW STRENGTH MATERIAL (CLSM)

- A. Comply with Section 033400.

2.16 BEDDING

- A. Comply with Section 312300 for granular bedding.

2.17 EPOXY BEDDING COMPOUND

- A. Use a 2-part, non-sag gel, rapid-setting epoxy adhesive conforming to ASTM C881, Type 4, Grade 3, Class B or C. Use the epoxy in an ambient temperature range of 40 to 100 degrees F.

2.18 WARNING TAPE

- A. A 6-inch-wide magnetically detectable warning tape with orange protective polyethylene jacket resistant to alkalis, acids, and other destructive elements continuously imprinted "CAUTION--COMMUNICATIONS CONDUIT BELOW" unless otherwise directed by the Utility.

2.19 CASTINGS

- A. The Utility will provide frames and covers.

PART 3 - EXECUTION

3.01 EXCAVATION AND BACKFILL

- A. Perform a "Z" pattern test pit at the proposed manhole location before installing ducts or manholes. If conflicts are identified, notify the Utility and Construction Manager immediately to assess the impacts and request that Verizon revise the Verizon Conduit Plans as necessary. Comply with Section 023219.
- B. Provide the Construction Manager and the Utility with a detailed schedule of the work. Notify the Utility in writing at least 15 days before beginning construction of utility facilities. Perform the work to minimize adverse impact to the Utility's operations.
- C. Perform work in a manner that is acceptable to the Utility, and in coordination with the Construction Manager. Provide the Utility with access to the work. Perform all work related to the Utility in the presence of the Utility's representative.
- D. Determine the location of surface and subsurface structures and utility facilities within the work site. Notify the Construction Manager when excavation is required within 10 feet of any existing utility facility and submit a plan to the Construction Manager for approval, detailing the proposed methods of excavating around the existing utility

facilities, and the proposed methods of protecting and supporting the existing utility facilities. Protect and support utility facilities encountered. Notify the Construction Manager and the Utility three (3) days before crossing any existing utility facilities, so that the Utility may send a representative to the work site at the time of excavation or construction.

- E. Remove and dispose of abandoned ducts, boxes, and appurtenances in direct conflict with the work or as directed by the Utility unless otherwise directed by the Construction Manager or Utility. Cap or plug ducts that are to be abandoned in a manner that is acceptable to the Utility.
- F. Comply with Section 312300. Dewater in accordance with Section 312319. If it is not possible to maintain the trench free of water as determined by the Construction Manager, lower the water to a level approved by the Construction Manager, excavate an additional 6 inches of the material below the bottom of the pipe, and backfill the undercut with compacted coarse aggregate, No. 57. Comply with Section 021600. Comply with Section 315000. Encase ducts as specified herein. Above the encasement, backfill with suitable material that is free from rock larger than 2 inches in diameter in lifts not exceeding 6 inches thick, loose measurement, and compact as specified in Section 312300. Do not use excavated pavement, including base and subbase material, as backfill. CLSM may be used as alternate backfill as specified in Section 312300 if approved by the Construction Manager and the Utility.
- G. Backfill and restore the pavement structure and match the surrounding condition before opening roads to traffic. For trenches not in sidewalk or roadways, do not leave trenches open overnight unless protected with caution fence and approved by the Construction Manager.

3.02 DUCT LAYOUT

- A. Follow the Verizon Conduit Plans, issued through Verizon, to build the conduit system. Do not deviate from the Verizon Conduit Plans without written approval by the Utility.
- B. Use 11 ¼, 22 ½, 45 and 90-degree bends to make offsets and changes in direction. Use a minimum radius of 3 feet. Ensure that the sum of all bends manhole to manhole, manhole to building, or manhole to pole does not exceed 270 degrees.
- C. Where other utility systems are encountered or are being installed, maintain a 12-inch minimum separation between utility facility and other system. Maintain a 12-inch minimum separation between utility facility and structures.
- D. Do not place utility facilities over valves or couplings in other piping systems. Do not construct conduit directly over or under and parallel to other facilities or structures.
- E. Minimum Cover: 36-inch minimum cover over the top ducts in the formation.

3.03 DUCT INSTALLATION

- A. Provide additional conduit or connections necessary to bypass obstructions, other utility facilities, and existing and proposed drainage facilities. Adjust the depth of the conduit bank to pass obstructions, other utility facilities, and existing and proposed drainage facilities.
- B. Use conduit spacers to provide 1 1/2-inch minimum separation between conduits. Locate spacers not less than 8 feet center-to-center along entire length of ducts. Secure ducts and spacers with polypropylene banding to prevent movement during concrete placement.
- C. Where existing cable is to remain, use split duct.
- D. Place duct couplings side-by-side horizontally but staggered at least 6 inches vertically.
- E. Glue the male end of each joint.
- F. Excavate trenches only for distances to be installed and backfilled during the same day. If approved by the Construction Manager, temporary protection may be used instead of backfilling trenches. Submit shop drawings for temporary protection.
- G. Install risers as directed by the Utility.

3.04 CONDUIT ENCASEMENT

- A. Encase all bends in concrete. Make duct encasement monolithic. Consolidate concrete around conduits as directed by the Utility.
- B. Encase each conduit in sand or granular bedding material. Provide at least 12 inches of sand or granular bedding material over the top row of ducts.
- C. Maintain 1 1/2-inch minimum separation between conduits and 3-inch minimum concrete encasement around ducts. Do not exceed the indicated outside dimensions of the duct by more than 1 inch vertically or 4 inches horizontally.

3.05 IDENTIFICATION

- A. Bury warning tape approximately 12 inches above all conduit banks.
- B. Align tape and protective plates within 3 inches of the centerline of the conduit bank.

3.06 HANDHOLES AND PULL BOXES

- A. Install cast-in-place concrete handholes and pull boxes unless directed by the Utility.

- B. Provide a 6-inch gravel base for open-bottom handholes.

3.07 MANHOLES

- A. Do not enter manholes without first verifying the adequacy of the oxygen supply and the absence of gas.
- B. Do not construct manholes over other Utility's facilities.
- C. Provide a base of 8 inches (minimum) for standard block concrete manholes and doghouse manholes and a base of 12 inches (minimum) for precast manholes of compacted coarse aggregate, No. 57 for leveling.
- D. Ensure that the minimum cover over the roof is 2 feet. Ensure that the maximum cover is 3 feet. Do not deviate from the cover requirements without written approval by the Verizon Conduit Engineer.
- E. Dimensions shown on the Verizon Conduit Plans are inside dimensions. Outside dimensions are approximately 1 foot greater than the inside dimensions.
- F. Fit manholes with racks and ladders according to manufacturer's recommendations and Bell System Practices, Section 622-520-100, Issue 7.
- G. Install manholes according to Section 333915. Secure bonding ribbons to a bonding and grounding ring.
- H. Use barrel blocks to construct chimneys, mortar inside and out.
- I. Construct 2 chimneys for each 12'L×6'W structure and one (1) chimney for each 8-foot L × 4-foot W structure.

3.08 CASTINGS

- A. Set casting in mortar beds or anchor castings to the masonry before finishing adjoining work with the same final elevation. Ensure that mortar attains a strength of 2500 pounds per square inch before opening to traffic. Set the manhole on the casting. If the manhole cover is loose or wobbles, grind to obtain a tight fit.

3.09 CASING

- A. Where indicated on the drawings, or directed by the Construction Manager, install solid or split casing; install split casing to protect existing conduit to remain. Install end seals at both ends of casing. Cut casing for split casing to prevent warping in the fabrication shop. No field splitting will be allowed. Bevel welding surfaces. Weld joints in a minimum of two (2) passes. Weld the entire circumference and length of

casing. Weld according to AWS D1.1. Construct casing to achieve a permanently leak-proof system. Repair galvanized coating according to ASTM A780.

3.10 ACCEPTANCE TEST

- A. Slug all ducts with a 4-inch slug.
- B. Rod each duct with a pull rope from manhole to manhole, manhole to building, and manhole to utility pole. Extend each rope a minimum of 15 feet into the manhole and coil neatly. Rod one duct of each duct bank with a toneable measuring tape. In duct banks, install the toneable measuring tape in the middle duct of the duct bank. Include the measurement on the as-built plan.
- C. Perform slugging, measuring tape and rope installation in the presence of the Utility.
- D. Repair or replace any portion of the duct through which the slug does not pass at the Contractor's expense.

3.11 AS-BUILT

- A. Within five (5) days of completion of each duct bank, submit to the Construction Manager and the Utility three (3) color copies of as-built plans on the Verizon Conduit Plan. Include the following:
 - 1. As-built locations of Verizon manholes and ducts (in red).
 - 2. Wall to wall measurements (in red) of all ducts installed. Confirm measurements with the toneable measuring tape.
 - 3. A cross section of the duct bank formation between structures.
- B. Submit as-built plans to:
Verizon
Centralized Engineering Services – Conduit Design
Attn: Krzysztof (Chris) Ogrodnik
657 Florida Grove Road
Hopelawn, New Jersey 08861
Telephone: 732-874-6189

3.12 CONTRACT CLOSEOUT

- A. Provide in accordance with Section 017700.

END OF SECTION 338000

NO TEXT ON THIS PAGE

SECTION 338101 - COMMUNICATIONS UTILITIES

PART 1 - GENERAL

1.01 SUMMARY

- A. This Section includes materials, installation, and testing of ducts, structures and related materials for communications utilities. The Utility will perform all cable work.

1.02 PAYMENT

- A. No separate payment shall be made for performing any Work required under this Section. All costs for Work shown on the plans and required by this Section shall be included in the applicable lump sum(s), unit price(s), or allowance(s) as set forth in Section 012901.
- B. Communications utilities or services that require relocation not shown on the plans or directed by the Construction Manager shall be paid for under the Utility Allowance as set forth in Section 012901.

1.03 REFERENCES

- A. ASTM International (ASTM):
 1. A36: Standard Specification for Carbon Structural Steel.
 2. A123: Standard Specification for Zinc (Hot-Dip Galvanized) Coatings on Iron and Steel Products.
 3. A252: Standard Specification for Welded and Seamless Steel Pipe Piles.
 4. A780: Standard Practice for Repair of Damaged and Uncoated Areas of Hot-Dip Galvanized Coatings.
 5. C1107: Standard Specification for Packaged Dry, Hydraulic-Cement Grout (Nonshrink).
 6. D1784: Standard Specification for Rigid Poly (Vinyl Chloride) (PVC) Compounds and Chlorinated Poly (Vinyl Chloride) (CPVC) Compounds.
 7. D2564: Standard Specification for Solvent Cements for Poly (Vinyl Chloride) (PVC) Plastic Piping Systems.
- B. American Welding Society (AWS):

1. D1.1: Structural Welding Code - Steel.

C. Underwriters Laboratories (UL):

1. 651: Standard for Schedule 40, 80, Type EB and A Rigid PVC Conduit and Fittings.

D. National Electrical Manufacturers Association (NEMA):

1. TC 2: Electrical Polyvinyl Chloride (PVC) Conduit.

2. TC 3: Polyvinyl Chloride (PVC) Fittings for Use with Rigid PVC Conduit and Tubing.

1.04 RELATED SECTIONS

A. General Conditions Article 4.7 – Shop Drawings and Other Submittals–

B. Section 012901 – Measurement and Payment.

C. Section 014300 - Quality Requirements.

D. Section 016100 - Control of Materials

E. Section 017700 - Contract Closeout.

F. Section 021600 - Excess Clean Fill, Contaminated Soil, and Groundwater Management and Disposal.

G. Section 033000 - Cast-in-Place Concrete.

H. Section 033400 – Controlled Low Strength Material (CLSM)

I. Section 312300 - Excavation and Fill.

J. Section 312319 - Dewatering.

K. Section 315000 - Excavation Support Systems.

L. Section 333915 - Manholes and Structures.

1.05 SUBMITTALS

A. Submit the following shop drawings in accordance with General Conditions Article 4.7.

1. Nonshrink grout.

2. Pull rope.
3. Epoxy bedding compound.
4. CLSM.
5. Aggregates and bedding.
6. Warning tape.
7. Certificate of compliance for casing pipe.
8. Certification of compliance for conduit and fittings.
9. Conduit cement.
10. Temporary protection for excavations.
11. All temporary works.

1.06 DEFINITIONS

- A. Utility: The company, agency, or other entity that provides service.
- B. duct: The general term for a conduit, either metallic or nonmetallic, for use underground.
- C. duct bank: A group of two (2) or more ducts in a continuous run between two (2) points.

1.07 QUALITY CONTROL

- A. Follow the accepted standards of ANSI, NEMA, IEEE, ASME, NBFU, ASHRAE, and ASTM for construction operations not specified in the Contract.
- B. Comply with the requirements specified in Section 014300.

1.08 DELIVERY, STORAGE, AND HANDLING

- A. Store ducts with ends capped. Store ducts with supports to prevent bending, warping, and deforming.

PART 2 - MATERIALS

2.01 CONCRETE MATERIALS

- A. Comply with Section 033000 for cast-in-place concrete.

2.02 UTILITY STRUCTURES

- A. The Utility will provide utility facility structures (manholes, junction boxes, pull boxes, vaults, splice boxes, etc.).

2.03 CONDUIT

- A. Use 4-inch PVC conduit made from virgin polyvinyl resins conforming to ASTM D1784, Class 12454-B. Ensure that the conduit exceeds all the property requirements including impact strength, chemical resistance, and flammability as listed in UL 651 and NEMA TC 2. Use rigid nonmetallic conduit that is Type II, Schedule 40 suitable for direct burial underground in grass and/or berm areas and Schedule 80 under roadways. Use fittings that are made from high-impact PVC, are the socket type, and are joined to the conduit using PVC solvent cement. Ensure that fittings, including couplings, conform to NEMA TC 3. Use solvent cement to join PVC conduit that is a heavy-bodied cement complying with ASTM D2564 and apply with a natural bristle or nylon brush. Use risers and sweeps that meet the same requirements.
- B. The Utility will provide conduit for services.

2.04 PULL ROPE

- A. Use polypropylene rope, minimum 1/2-inch diameter.

2.05 CASING

- A. For casing, use ASTM A252 steel pipe with 3/8-inch minimum wall thickness and galvanize according to ASTM A123. Size the casing based on the size and number of conduits in the duct bank. At the ends of casings, install end seals. Use 1/8-inch minimum thickness synthetic rubber end seals with Grade 304 stainless steel banding straps and mastic strips to seal the edges. If required by the Utility, also use rubber link modular seals with stainless steel hardware.

2.06 STEEL PLATE

- A. For temporary protection of open excavations, use steel plates conforming to ASTM A36.

2.07 COARSE AGGREGATE

- A. Use coarse aggregate, No. 57 that complies with Section 312300.

2.08 MORTAR

- A. Mix one (1) part cement to two (2) parts fine aggregate. Add water to form the proper consistency. Do not temper mortar or use mortar after it has begun to set.

2.09 GROUT

- A. Nonshrink Grout: Use non-shrink grout of a plastic consistency that conforms to ASTM C1107. Ensure that the grout has a working time of at least 30 minutes from the time the water is added. Match the color of the hardened grout, where visible, to the color of the adjacent hardened concrete. Include 1-day strength tests as part of the performance requirements of ASTM C1107. Ensure that the grout contains no more than 0.05 percent chlorides or 5.0 percent sulfates by weight. Use Sikagrout 212 by Sika Corporation, CG-86 N.E. Construction Grade Grout by W.R. Meadows, Inc., Euclid NS Grout by Euclid Chemical Co., or approved equal.

2.10 CONTROLLED LOW STRENGTH MATERIAL (CLSM)

- A. Comply with Section 033400.

2.11 SAND

- A. Use sand that complies with Section 312300.

2.12 BEDDING

- A. Comply with Section 312300 for granular bedding.

2.13 WARNING TAPE

- A. A 6-inch-wide magnetically detectable warning tape with orange protective polyethylene jacket resistant to alkalis, acids, and other destructive elements continuously imprinted "CAUTION—COMMUNICATIONS CONDUIT BELOW" or "CAUTION—FIBER OPTIC CABLE BELOW", as applicable, unless otherwise directed by the Utility.

2.14 CASTINGS

- A. The Utility will provide frames and covers.

PART 3 - EXECUTION

3.01 EXCAVATION AND BACKFILL

- A. Determine the location of surface and subsurface structures and utilities within the work site. Notify the Construction Manager when excavation is required within 10 feet of any existing utility facilities and submit a plan to the Construction Manager for approval, detailing the proposed methods of excavating around the existing utilities, and the proposed methods of protecting and supporting the existing utilities. Protect and support utility facilities encountered. Notify the Construction Manager and the Utility three (3)

days before crossing any existing utilities so that the Utility may send a representative to the work site at the time of excavation or construction.

- B. Comply with the requirements specified in Section 312300. Dewater in accordance with the requirements specified in Section 312319. If it is not possible to maintain the trench free of water as determined by the Construction Manager, lower the water to a level approved by the Construction Manager, excavate an additional 6 inches of the material below the bottom of the pipe, and backfill the undercut with compacted Dense Graded Aggregate (DGA). Ensure that trenches are kept free of standing water during the installation. Install conduit on a 6-inch layer of compacted Dense Graded Aggregate (DGA). Comply with the requirements specified in Section 021600. Comply with the requirements specified in Section 315000. Do not use excavated pavement, including base and subbase material, as backfill.
- C. Ensure that conduit is centered in the trench and is held firmly in place while the trench is backfilled. Fill the trench sides around the conduit with Dense Graded Aggregate (DGA) to the top of the conduit. If more than one (1) conduit is in the trench, then also center fill. Place additional Dense Graded Aggregate (DGA) over the conduit to a depth of 6 inches and compact as specified in Section 312300. Above this depth, backfill with suitable material that is free from rock larger than 2 inches in diameter in lifts not exceeding 6 inches thick, loose measurement, and compact as specified in Section 312300. CLSM may be used as alternate backfill as specified in Section 312300 with the approval of the Utility and the Construction Manager. Restore disturbed areas to original conditions, the conditions specified in the Contract, or as directed by the Construction Manager.
- D. Backfill and restore the pavement structure and match the surrounding condition before opening roads to traffic. The Contractor may use temporary protection instead of backfilling trenches in the roadway and sidewalk. If using temporary protection, submit working drawings for approval. For trenches not in sidewalk or roadways, do not leave trenches open overnight unless protected with caution fence and approved by the Construction Manager.

3.02 DUCT LAYOUT

- A. Make 11 1/4, 22 1/2, 45, and 90-degree bends to accomplish offsets or turns.
- B. For risers, use a 45-degree sweep at the base of the pole.
- C. Construct bends with a minimum radius of 3 feet.
- D. Construct conduit with a minimum of bends. Do not install more than two (2) 90-degree bends between utility facility structures.

- E. Where other utility facility systems are encountered or are being installed, maintain a 12-inch minimum separation between utility facility and other system. Maintain a 12-inch minimum separation between utility facilities and structures.
- F. Do not place ducts over valves or couplings in other piping systems. Do not construct conduit directly over or under and parallel to other facilities or structures.
- G. Provide additional conduit or connections necessary to bypass obstructions, other utilities, and existing and proposed drainage facilities. Adjust the depth of the conduit bank to pass obstructions, other utilities, and existing and proposed drainage facilities.

3.03 DUCT INSTALLATION

- A. Provide the Construction Manager and the Utility with a detailed schedule of the Work. Notify the Utility in writing at least 15 days before beginning construction of ducts. Perform the Work to minimize adverse impact to the Utility's operations.
- B. Perform work in a manner that is acceptable to the Utility, and in coordination with the Construction Manager. Provide the Utility with access to the Work. Perform all work related to the utility facility in the presence of the Utility's representative.
- C. Do not use disc grinders to cut conduit. Cut conduit square and true and ensure the ends butt together over their full circumference.
- D. Construct conduit with at least 10-foot sections. The Contractor may use a shorter section to complete a conduit run into a structure. At the end of the workday, cap all conduit that does not terminate in a structure.
- E. Make connections according to the manufacturer's directions using manufacturer-recommended solvents. If connecting nonmetallic conduit to metallic conduit or other existing conduit, use a manufacturer's recommended adapter.
- F. Ensure that conduit used for fiber optic cables meets the minimum bend and radius requirements of the Utility.
- G. The Contractor may cut off damaged ends of conduit, and use the remainder of the undamaged conduit, provided at least a 9-foot length remains. The Construction Manager will not allow other repairs to conduit or fittings. Remove broken, chipped, cracked, or impaired conduit and fittings.
- H. If installing conduit in existing utility facility structures, cut additional holes in the structure to admit the conduit.
- I. Grout around conduit installed in utility facility structures.

- J. If unable to install conduit with sufficient grade to provide drainage, install T-drains consisting of standard pipe tee and nipple for conduit at the lowest point of the conduit run.
- K. Install pull rope marked in 1-foot increments for the length of the conduit. Cap and seal the conduit leaving the tape inside.
- L. Place duct couplings side-by-side horizontally but staggered at least 6 inches vertically.
- M. Excavate trenches only for distances to be installed and backfilled during the same day. If approved by the Construction Manager and the Utility, temporary protection may be used instead of backfilling trenches. Submit shop drawings for temporary protection.
- N. Install risers as directed by the Utility.
- O. Install conduit with 3 feet of cover.
- P. Ensure a watertight system.
- Q. Remove and dispose of abandoned ducts, boxes, and appurtenances in direct conflict with the work or as directed by the Utility unless otherwise directed by the Construction Manager or Utility. Cap or plug ducts that are to be abandoned in a manner that is acceptable to the Utility.

3.04 IDENTIFICATION

- A. Bury warning tape approximately 18 inches below finish grade.
- B. Align tapes and protective plates within 3 inches of the centerline of the conduit bank.

3.05 UTILITY STRUCTURES

- A. Install utility facility structures as directed by the Utility and as specified in Section 333915.
- B. Provide a base of 6 inches of coarse aggregate No. 57 for all utility facility structures.
- C. Do not enter utility facility structures without first verifying the adequacy of the oxygen supply and the absence of gas.
- D. Backfill as specified in Section 312300.

3.06 CASTINGS

- A. Set castings in mortar beds or anchor castings to the masonry before finishing adjoining work with the same final elevation. Ensure that mortar attains a strength of 2500 pounds

per square inch before opening to traffic. Set the cover on the casting. If the cover is loose or wobbles, grind to obtain a tight fit.

3.07 CASING

3.08 Where indicated on the drawings, or directed by the Construction Manager, install solid or split casing; install split casing to protect existing conduit to remain. Install end seals at both ends of casing. Cut casing for split casing to prevent warping in the fabrication shop. No field splitting will be allowed. Bevel welding surfaces. Weld joints in a minimum of two (2) passes. Weld the entire circumference and length of casing. Weld according to AWS D1.1. Construct casing to achieve a permanently leak-proof system. Repair galvanized coating according to ASTM A780.

3.09 ACCEPTANCE TEST

- A. Clean conduit runs, including existing conduit to be used. Pull a bristle brush of a diameter approximately 1/4 inch greater than the duct inside diameter through each duct to remove debris.
- B. After cleaning, test each conduit by pulling through a metal ball with a diameter at least 85 percent of the nominal inside diameter of the conduit, to ensure that the conduit is free of obstruction or foreign material.
- C. Install pull rope in each conduit. Install toneable measuring tape in one (1) duct. In duct banks, install the toneable measuring tape in the middle duct of the duct bank.
- D. Repair or replace any portion of the duct through which the mandrel and brush will not pass at the Contractor's expense.

3.10 AS-BUILT

- A. Within five (5) days of completion of each duct bank, submit to the Construction Manager and the Utility three (3) color copies of scaled as-built plans. Include the following:
 - 1. Annotations for the locations of items of construction related to each Utility.
 - 2. Show stationing and distance references to the curb line.
 - 3. Depth of conduit at a minimum of 100-foot increments along the line.

3.11 CONTRACT CLOSEOUT

- A. Provide in accordance with Section 017700.

END OF SECTION 338101

NO TEXT ON THIS PAGE

SECTION 340113 - OPERATION AND MAINTENANCE OF ROADWAYS

PART 1 - GENERAL

1.01 SUMMARY

- A. This Section specifies requirements for furnishing and installing a multiple component, wet reflective traffic marking system in reasonably close conformance to the dimensions and lines shown on the Contract Drawings. The wet reflective thermoplastic pavement striping material shall be applied to the road surface in a molten state by mechanical means with surface application of wet reflective bonded core elements and glass beads.

1.02 PAYMENT

- A. No separate payment shall be made for performing any Work required under this Section. All costs for Work required by this Section shall be included in the applicable lump sum(s), unit price(s), or allowance(s) as set forth in Section 012901.

1.03 REFERENCES

- A. American Association of State Highway and Transportation Officials (AASHTO):
 - 1. AASHTO M 247: Specification for Glass Beads Used in Pavement Markings.
 - 2. AASHTO T 250: Standard Method of Test for Thermoplastic Traffic Line Material.
- B. American Society for Testing and Materials (ASTM) International:
 - 1. ASTM D 36: Test Method for Softening Point of Bitumen (Ring-and-Ball Apparatus).
 - 2. ASTM D 92: Test Method for Flash and Fire Points by Cleveland Open Cup Tester.
 - 3. ASTM D 153: Test Method for Specific Gravity of Pigments.
 - 4. ASTM D 256: Test Methods for Determining the Izod Pendulum Impact Resistance of Plastics.
 - 5. ASTM D 570: Test Method for Water Absorption of Plastics.
 - 6. ASTM D 1155: Test Method for Roundness of Glass Spheres.
 - 7. ASTM D 1213: Test Method for Crushing Resistance of Glass Spheres.
 - 8. ASTM D 1214: Test Method for Sieve Analysis of Glass Spheres.

9. ASTM D 2240: Test Method for Rubber Property – Durometer Hardness.
10. ASTM D 4960: Test Method for Evaluation of Color for Thermoplastic Traffic Marking Materials.
11. ASTM D 6628: Specification for Color of Pavement Marking Materials.
12. ASTM E 1349: Test Method for Reflectance Factor and Color by Spectrophotometry Using Bidirectional Geometry.
13. ASTM E 1710: Test Measurement for Measurement of Retro reflective Pavement Marking Materials with CEN-Prescribed Geometry Using a Portable Retroreflectometer.
14. ASTM E 2176: Test Method for Measuring the Coefficient of Retroreflected Luminance of Pavement Markings in a Standard Condition of Continuous Wetting (RL-Rain).
15. ASTM E 2177: Test Method for Measuring the Coefficient of Retro reflected Luminance (RL) of Pavement Markings in a Standard Condition of Wetness.
16. ASTM E 2832: Test Method for Measuring the Coefficient of Retro reflected Luminance of Pavement Markings in a Standard Condition of Continuous Wetting (RL-2).
17. ASTM G 154: Standard Practice for Operating Fluorescent Ultraviolet (UV) Lamp Apparatus for Exposure of Non-Metallic Materials.

C. Federal Highway Administration (FHWA):

1. FP-03 Standard Specifications for the Construction of Roads and Bridges on Federal Highway Projects.
2. MUTCD Manual on Uniform Traffic Control Devices for Streets and Highways.

D. Federal Standards:

1. FED. STD 595B Colors used in Government Procurements.
2. FED. STD 595C Colors used in Government Procurements.

1.04 RELATED SECTIONS

- A. General Conditions Article 4.7 – Shop Drawings and Other Submittals.
- B. Section 012901 – Measurement and Payment.

C. Section 016100 – Control of Materials

D. Section 017700 – Contract Closeout

1.05 WARRANTY

A. The completed marking installation shall be warranted to the DEP against peeling, chipping, flaking, delamination and shoving for a period of one year from the date of issuance of the Certificate of Final Completion. The warranty shall run to the DEP's benefit and shall grant the DEP a direct right of action. The manufacturer shall warrant that the materials provided to the applicator are free from manufacturing defects and conform to the standards listed here within. The applicator shall warrant that the workmanship has been completed complying to the installation methods here within.

1.06 DELIVERY, STORAGE, AND HANDLING

A. Comply with the requirements in Section 016100.

B. The thermoplastic material shall be packaged in suitable containers to which it will not adhere during shipment or storage. Each container shall be sealed at the point of manufacture and plainly marked with the color, basic resin type, wet reflective elements and glass bead types included in the mix, manufacturer's name, batch number and date of manufacture, and a statement stating the contents meet the requirements of this Section. Each batch manufactured shall have its own separate number. The label shall warn the user that the material shall not be heated in excess of 440 degrees F.

C. The wet reflective elements and glass spheres for drop-on application shall be shipped in strong moisture resistant bags. Each bag shall be marked with the name and address of the manufacturer, the name and weight of the material, a statement confirming that the contents meet the requirements of this Section, date of manufacture, and batch number.

D. Primer shall be shipped in pails, drums or other strong substantial containers. Each container shall be plainly marked with the brand name of the product, name and address of the manufacturer, date of manufacture, quantity of material, date of expiration or shelf life, and appropriate hazard warnings. Primers shall be shipped to the construction site with instructions for use affixed to each container.

1.07 SUBMITTALS

A. Submit the following in accordance with the requirements of General Conditions Article 4.7.

1. Product Data: Detailed catalog cuts and manufacturer's specifications of thermoplastic materials, reflective glass spheres and primer.

2. Manufacturer Test Reports: Test data demonstrating conformance to the requirements of this Section.
3. Manuals, Warrantees/Guarantees: Warranty labels.

PART 2 - PRODUCTS

2.01 GENERAL

- A. The thermoplastic material shall be applied by methods as shown on the Contract Drawings and be immediately followed by application of wet reflective bonded core elements and glass beads. Upon cooling to normal pavement temperatures the resulting traffic marking shall produce a pavement marking of specified thickness and of the width and dimensions shown on the Contract Drawings that is retroreflective in dry and continuous wet conditions and capable of resisting deformation by traffic.

2.02 MATERIALS

- A. The thermoplastic material shall be homogeneously composed of pigment, binder, glass beads and wet reflective bonded core elements and shall be free of skins, dirt and foreign debris.
- B. The binder shall be based on maleic modified rosin ester resin and high boiling point plasticizer. The binder shall be a minimum of 50 percent maleic modified rosin ester.
- C. The pigment beads and binder shall be well dispersed in the resin.
- D. The reflective media shall be made up of wet reflective bonded core elements and glass beads and shall conform to the following requirements:
 1. Glass Beads: Index of refraction of 1.5 when tested by immersion method at 77 degrees F. The glass beads shall have a minimum of 70 percent rounds as measured in accordance with ASTM D 1155. The surface of the glass beads shall be free of pits and scratches. The glass beads retained on the # 40 U.S. Mesh sieve (425 microns) shall have minimum crush strength of 30 pounds in accordance with ASTM D 1213.
 2. Glass Beads (Pre-mix): Conforming to AASHTO M 247 (Type I) and FP-03 (Type III) and shall not require surface treatment.
 3. Glass Beads (Surface-drop): Glass spheres in the size range of Type III shall be surface treated with an adhesion coating. Bead size distribution shall conform to the requirements specified in Table 1 herein.
 4. Gradation of the Second Surface Drop of Glass Bead

5. The gradation of the second drop shall meet or be within the limits shown in Table 1 herein.

Table 1. Gradation of the Second Surface Drop of Glass Bead
Common Bead Types with Liquid Pavement Markings
Bead Gradations – Mass Percent Passing (ASTM D1214)

US Mesh	Micron	AASHTO M247 Type I	FP-03 718.19 Type III
12	1700	-	100
14	1410	-	95-100
16	1180	100	80-95
18	1000	-	10-40
20	850	95-100	0-5
25	710	-	0-2
30	600	75-95	-
40	425	-	-

- E. Wet Reflective Bonded Core Elements (Pre-mix and First Surface-drop): Bonded core reflective elements shall contain either clear or yellow tinted microcrystalline ceramic beads bonded to the core. “Dry-performing” microcrystalline ceramic beads bonded to the core shall have a minimum index of refraction of 1.70 when tested using the liquid oil immersion method specified herein. “Wet performing” microcrystalline ceramic beads bonded to the core shall have a minimum index of refraction of 2.30 when tested using the liquid oil immersion method indicated herein.
 1. Bead Testing Procedure: Refractive index of beads by liquid oil immersion (Becke Method). Obtain from the bead Manufacturer an independent testing lab report for the glass beads meeting the latest AASHTO M 247.
 - a. The size and quality of the beads shall be such that the performance requirements for the retroreflective pliant polymer (actual thermoplastic) are met.
 - b. Element size distribution shall conform to the requirements specified in Table 2 below:

Table 2: Element Size

Element Gradations Mass Percent Passing (ASTM D1214)		
U.S. Mesh	Micron	“S” Series Elements
12	1700	85-100
14	1410	70-96
16	1180	50-90
18	1000	5-60
20	850	0-25
30	600	0-7

c. Surface Treatment: The bonded core elements shall be surface treated to optimize embedment and adhesion to the high build waterborne binder.

F. Primer for use on both bituminous and Portland cement concretes shall be of the type recommended by the manufacturer of the thermoplastic material and shall dry tack-free in under five (5) minutes.

2.03 THERMOPLASTIC MATERIALS – GENERAL

A. Use thermoplastic material with the following characteristics:

1. Does not deteriorate upon contact with pavement materials, petroleum droppings from traffic, and chemicals such as sodium chloride or calcium chloride that are used to prevent formation of ice on roadways or streets.
2. Does not scorch or discolor if kept at the manufacturer’s recommended application temperature for any length of time, or deteriorate if kept at the manufacturers recommended application temperature or at minimum 400 degrees F, for four (4) hours.
3. Has a temperature versus viscosity characteristic that remains constant from batch to batch through three to four (3-4) re-heat cycles.

B. Thermoplastic material shall be supplied in either granular or block form.

2.04 THERMOPLASTIC COMPOSITION

A. Composition: Pigment, glass beads, wet reflective bonded core elements and binder shall be uniformly dispersed in the resin. The thermoplastic material shall comply with requirements specified in Table 3 herein.

Table 3 - Composition

Wet Reflective Thermoplastic with Bonded Core Elements		
Component	Weight Percent	
	White	Yellow
Binder	20% minimum	20% minimum
Type I Glass Spheres	20% minimum	20% minimum
Type III Glass Spheres	15% minimum	15% minimum
Bonded Core Elements (color matched component)	5% minimum	None
Bonded Core Elements (color matched component)	None	5% minimum
TiO ₂ , Type II Rutile	10% minimum	As needed
Pigment Yellow 83 (Lead-Free)	None	See Note 1
Calcium Carbonate and Inert Filler (200 mesh sieve)	30% Minimum	See Note 1

Note 1- The amount of yellow pigment, calcium carbonate and inert fillers shall be at the option of the manufacturer, providing all other requirements of this Section are met.

- B. The thermoplastic material shall be produced without the use of lead chromate or arsenic.
- C. The thermoplastic material shall contain glass beads as specified in Paragraph 2.02.D.
- D. The thermoplastic material shall contain wet reflective bonded core elements (microcrystalline ceramic beads) as specified in Paragraph 2.02.E.
- E. The thermoplastic material shall be formulated and manufactured from materials specifically compounded for traffic markings.
- F. The pavement marking shall be homogenous with even distribution of pigments, beads and wet reflective bonded core elements throughout the plastic matrix.
- G. The pavement marking shall be uniform throughout the plastic matrix.
- H. The pavement marking shall resist delamination caused by cold weather.

2.05 PHYSICAL CHARACTERISTICS OF THERMOPLASTIC

- A. Storage Life: The thermoplastic material shall melt uniformly with no evidence of skins or un-melted particles for a period of one year from the date of manufacture.
- B. Yellowness Index: The thermoplastic material shall comply with ASTM D 4960 and shall meet yellowness index measurements in accordance with ASTM E 1349 using a 2 degree observer and D 65 illuminant. The yellowness index for the white thermoplastic shall not exceed 15.
- C. Set to Bear Traffic: When applied at a temperature range of 412.5 degrees F plus or minus 12.5 degrees F and a thickness of 60 mils to 185 mils (1/16 inches to 3/16 inches) the thermoplastic material shall set to bear traffic in not more than 2 minutes when the air

and road temperature is 50 plus or minus 3 degrees F and not more than ten minutes when the air and road temperature is 90 plus or minus 3 degrees F.

- D. Cracking Resistance at Low Temperature: After heating the thermoplastic for 240 plus or minus 5 minutes at 425 plus or minus 3 degrees F and then applying to concrete blocks, and cooling to 15 plus or minus 3.6 degrees F the material shall show no cracks in accordance with AASHTO T 250 Section 12.
- E. Impact Resistance: After heating the thermoplastic for 240 plus or minus five (5) minutes at 425 plus or minus 3 degrees F and making test specimens and testing in accordance with ASTM D 256, Method A (un-notched), the impact resistance shall be a minimum of 8.8 inch-lbs (1.0 Joules) in accordance with AASHTO T 250 Section 14.
- F. Softening Point: After heating the thermoplastic for 240 plus or minus five (5) minutes at 425 plus or minus 3 degrees F and testing in accordance with ASTM D 36, the materials shall have a softening point of 215 plus or minus 15 degrees F.
- G. Flowability: After heating the thermoplastic for 240 plus or minus 5 minutes at 425 plus or minus 3 degrees F and testing for flowability, the white thermoplastic shall have a maximum residue of 18 percent and the yellow thermoplastic shall have a maximum residue of 21 percent in accordance with AASHTO T 250 Section 11.
- H. Flowability with Extended Heating: After heating the thermoplastic for eight (8) hours plus or minus 0.5 hours at 425 plus or minus 3 degrees F, with stirring the last six (6) hours, and testing for flowability, the thermoplastic shall have a maximum residue of 28 percent in accordance with AASHTO T 250 Section 17.
- I. Flash Point: When tested in accordance with ASTM D 92, the thermoplastic shall have a flash point not less than 475 degrees F.
- J. Indentation Resistance: The thermoplastic material shall comply with ASTM D 2240 Shore Durometer, A2. Durometer and panel at 110 degrees F with a 4.4 pound load applied. Measurement shall be taken after 15 seconds. The thermoplastic shall have a minimum value of 40 and a maximum value of 75. Ensure that the intermix is thoroughly mixed and uniform in the test samples to avoid erratic measurement values.
 - 1. During measurement of wet reflective thermoplastic containing large elements or glass beads, the durometer probe may impact a large bead or large element during the test resulting in a much higher than expected result. If the value is unreasonably high, retest in another location on the sample at no additional cost to the NJDEP.

2.06 CHARACTERISTICS OF FINISHED PAVEMENT MARKING

- A. Retroreflectance: Initial retroreflectance shall be as specified in Table 4 herein.

Table 4: Retroreflectance

Average Initial Retroreflectivity* Average values over many applications (mcd (ft-2) (fc-1))		
	White	Yellow
Dry (ASTM E1710)	500	405
Wet recovery (ASTM E2177)	500	405
Wet Continuous (ASTM E2176)	180	150

*Note : Average initial retroreflectivity values represent average performance for smooth pavement surfaces. Actual test results may vary due to differences in pavement type and surface roughness. Increased element drop rate may be necessary to compensate for increased surface area characteristics of rough pavement surfaces.

- B. The initial retroreflectance of a single installation shall be the average value determined in accordance with the measurement and sampling procedures specified in ASTM E 1710, using a 98.4 feet retroflectometer. RL shall be expressed in units of millicandelas per square foot per foot-candle (mcd(ft⁻²)(fc⁻¹)).
- C. Measure initial retroreflective performance of pavement marking no sooner than four (4) days after application.
- D. Wet retroreflectance values measured under a “condition of continuous wetting” (simulated rain) shall be in accordance with ASTM E2832, and to reduce variability between measurements, the test method shall be performed in a controlled laboratory environment while the marking is positioned with a 3 to 5 degree lateral slope. Measurements shall be reported as the average of the minimum of three locations. The Contractor shall apply samples of the completed finished product to flat panels during application and deliver to the lab for testing.
- E. On the Road Track-Free Time
 - 1. When applied at a temperature range of 412.5 plus or minus 12.5 degrees F and a thickness of 60 mils to 185 mils (1/16 inches to 3/16 inches) the material shall set to bear traffic in not more than 2 minutes when the air and road temperature is 50 plus or minus 3 degrees F and not more than 10 minutes when the air and road temperature is 90 plus or minus 3 degrees F.
 - 2. Track Free shall be considered as the condition where no visual deposition of the traffic marking to the pavement surface is observed when viewed from a distance of 50 feet, after a free-rolling traveling vehicle’s tires have passed over the line.

- F. Color After Application: The color of the applied white and yellow pavement markings (with elements and beads) shall conform to the daytime and nighttime color requirements in ASTM D 6628.
1. White Reflectance: Daylight reflectance (Cap Y) measured at 45 and 0 degrees shall be 35 percent minimum.
 2. White Color: The color shall reasonably match FED. STD. 595B, color 17886 and shall be within the following chromaticity limits “color box” defined by plotting the following four (x,y) pairs on a C.I.E. 1931 chromaticity diagram:
 $(x_1, y_1) = (0.355, 0.355)$
 $(x_2, y_2) = (0.305, 0.305)$
 $(x_3, y_3) = (0.285, 0.325)$
 $(x_4, y_4) = (0.335, 0.375)$
 3. Yellow Reflectance: Daylight reflectance (Cap Y) measured at 45 and 0 degrees shall be 25 percent minimum.
 4. Yellow Color: The color shall reasonably match FED. STD. 595B, color 13538 and shall be within the following chromaticity limits “color box” defined by plotting the following four (x,y) pairs on a C.I.E. 1931 chromaticity diagram:
 $(x_1, y_1) = (0.560, 0.440)$
 $(x_2, y_2) = (0.490, 0.510)$
 $(x_3, y_3) = (0.420, 0.440)$
 $(x_4, y_4) = (0.460, 0.400)$
- G. The thermoplastic material shall resist smearing or spreading under normal traffic conditions below 120 degrees F.
- H. The finished pavement marking shall maintain its original dimensions and placement.
- I. The finished pavement marking shall be free from tack below 120 degrees F and shall not be slippery when wet.

PART 3 - EXECUTION

3.01 APPLICATION EQUIPMENT

- A. Equipment shall be capable of providing uniform heating of thermoplastic materials to temperatures exceeding 390 degrees F.
- B. Equipment shall be capable of mixing and agitating the molten thermoplastic to provide a homogenous mixture and prevent settling of intermixed beads and wet reflective bonded core elements.

- C. Equipment shall be capable of maintaining the thermoplastic material in a plastic state in all mixing and conveying parts, including the line dispensing device until applied.
- D. Equipment shall be capable of producing varying widths and thickness of thermoplastic pavement markings.
- E. The equipment shall be a mobile, truck mounted and self-contained pavement marking machine or a walk behind hand cart applicator with an accompanying mobile pre-meter.
- F. Mobile truck mounted applicators shall be capable of traveling at a uniform, predetermined speed over variable road grades to produce uniform application of thermoplastic material, following straight lines and making normal curves in a true arc. The equipment shall be capable of air-blasting the pavement, applying the thermoplastic material and immediately dropping the wet reflective bonded core elements and then glass beads in a single pass at speeds up to 8 mph.
- G. Hand cart applicators shall be capable of uniform application of pavement marking material at walking speeds, following straight lines and making tight turns symbols and legends. Mobile equipment shall be available to air blast the areas immediately prior to hand cart application of thermoplastic. The hand cart shall be capable of applying the thermoplastic material and immediately dropping the wet reflective bonded core elements and then glass beads in a single pass at walking speeds.
- H. The equipment shall be capable of application of wet reflective bonded core elements and then glass beads to the surface of the pavement marking by double drop application. The element dispenser for the first drop, wet reflective bonded core elements, shall be attached to the pavement marking machine in such a manner that the elements are dispensed closely behind the thermoplastic application device (ribbon gun, screed and spray gun). The glass bead dispenser for the second drop shall be attached to the pavement marking machine in such a manner that the beads are dispensed immediately after the first drop (wet reflective bonded core elements).
- I. The applicator for the wet reflective bonded core elements and glass beads shall be equipped with an automatic cut-off control that is synchronized with the cut-off of the thermoplastic material.
 - 1. The applicator for the wet reflective bonded core elements and glass beads shall be capable of delivering a uniform drop rate at variable thermoplastic application speeds.
 - 2. The wet reflective bonded core elements and glass spheres shall be applied such that they appear uniform on the entire pavement marking.
 - 3. The bonded core elements and glass beads shall be applied such that they are embedded 50 percent to 60 percent for adhesion to the thermoplastic marking.

4. The melt kettle shall be equipped with an automatic temperature control device and thermometer to thermostatically control the temperature and prevent overheating of the thermoplastic material. It shall be equipped with sufficient agitation to prevent settling of the beads and elements.
5. The applicator shall meet the requirements of the National Fire Protection Association and the State of New Jersey for work performed in New Jersey.

3.02 INSTALLATION

A. General

1. Apply pavement markings at the locations and in accordance with the patterns and dimensions shown on the Contract Drawings and the FHWA's "MUTCD".
2. Before commencing any pavement marking Work, submit a schedule of operations to the Construction Manager for approval.
3. When pavement markings are applied under traffic conditions, provide all necessary qualified personnel, flags, markers and signs to maintain and protect traffic and to protect marking operations and the applied markings until thoroughly set. Perform lane and work area closures in accordance with the requirements of the Contract Documents.
4. Apply pavement markings in the general direction of traffic. Applications against the direction of traffic flow will not be permitted.
5. Remove all tracking marks, spilled thermoplastic and thermoplastic applied in unauthorized areas, to the satisfaction of the Construction Manager.
6. When necessary, establish marking alignment points at 25-foot intervals throughout the length of the marking area, or as otherwise approved by the Construction Manager.
7. Apply thermoplastic pavement markings to dry pavement surfaces. At the time of installation the pavement surface temperature shall be a minimum of 55 degrees F, the ambient temperature shall be a minimum of 49 degrees F and rising, and the relative humidity shall be less than 85 percent.

B. Surface Cleaning and Preparation of Pavement

1. Clean the pavement surfaces to be marked to the satisfaction of the Construction Manager immediately prior to priming and marking application. Remove existing markings that show obvious signs of degradation or loss of adhesion. Perform surface cleaning and preparation only in the area of the thermoplastic markings application.

2. At the time of application of the thermoplastic material, ensure that all pavement surfaces are dry, free of moisture, free of oil, dirt, dust, grease and similar foreign materials and that the primer is tack-free. All curing compounds used on newly placed Portland cement concrete surfaces shall be removed.
3. On newly placed concrete pavements, cleaning operations shall not begin until sufficient cure time has elapsed after the placement of concrete. Newly placed concrete pavements shall be cleaned by either sandblasting or water blasting. When water blasting is performed, pavement markings shall be applied no sooner than 24 hours after the blasting has been completed. The extent of the blasting Work shall be to clean and prepare the concrete surface such that:
 - a. There is no visible evidence of curing compound on the peaks of the textured concrete surface.
 - b. There are no heavy puddled deposits of curing compound in the valleys of the textured concrete surface.
 - c. All remaining curing compound is intact; all loose and flaking material is removed.
 - d. The peaks of the textured pavement surface are rounded in profile and free of sharp edges and irregularities.
4. Restrictions - If the pavement surface contains heavy tines or very large aggregate used in open grade friction course or stone matrix asphalt mixes perform additional surface preparation prior to application of thermoplastic pavement markings at no additional cost to the DEP.

C. Application

1. Apply a primer to all pavement surfaces (new and existing) to be marked. Apply primer to bituminous concrete and Portland cement concrete pavements, as applicable, at the rates and in accordance with the recommendations of the manufacturer of the thermoplastic material. The primer shall dry tack-free in less than five (5) minutes.
2. Thickness: Thermoplastic material shall typically be applied to the pavement surface by the extrusion method (when shown on the Contract Drawings, pavement marking re-capping may be applied by utilizing the spray method). Place thermoplastic markings in accordance with the following requirements:
 - a. The installation method utilized shall be capable of installing lines between 3 to 8 inches in width and of generally uniform cross Section.

- b. The standard line thickness shall be not less than 125 mils (1/8 inch) nor more than 185 mils (3/16 inch).
 - c. The standard re-capping line thickness shall be a minimum thickness of 60 mils (1/16inch).
3. Reflective Media Application: The specified reflective media shall be dropped at rates to achieve the following coating weights per Tables 5 and 6 herein.

Table 5. Element Application Rates

Units	Wet Reflective Bonded Core Elements
Pounds per 4-inch linear foot	0.022
Pounds per 100 sq ft	6.6

Table 6. Glass Bead Application Rates

Units	Type III Bead
Pounds per 4-inch linear foot	0.026
Pounds per 100 sq ft	7.8

- 4. Adhesion: Ensure that the thermoplastic marking is well adhered to the road surface, and that the glass spheres and wet reflective bonded core elements are well adhered to the binder with 50 percent to 60 percent embedment.
- 5. Retroreflectivity: Ensure that the reflectorized thermoplastic pavement marking meets the performance criteria in Table 4 herein.
- 6. Upon cooling to ambient pavement temperature, the resultant marking shall be an adherent reflectorized strip of a thickness not less than 1/16 inch nor more than 3/16 inch, and of the width and dimensions shown on the Contract Drawings, capable of resisting deformation by traffic. The exposed marking surface shall be smooth, with no pockmarks, blisters or other surface blemishes evidencing improper application, improper temperature or equipment malfunction. The pavement markings shall show a smooth alignment with continuous uniformity of the required dimensions and widths.

3.03 INSPECTION AND TESTING

- A. At any time throughout the duration of the Contract, the Contractor shall provide unrestricted access to his application equipment for inspection by the Construction Manager, or a manufacturer’s materials representative.
- B. During the application of the thermoplastic marking, the Construction Manager may request the following tests to verify application to the parameters required in this Section:

1. Thickness: At appropriate locations along the site installation location, the Construction Manager may obtain a sample of the molten thermoplastic and place it onto a test panel of aluminum for the purposes of checking proper film thickness. The Contractor shall apply the thermoplastic without bonded core elements or glass spheres onto the test panel. Upon hardening, the thickness will be verified by the Construction Manager to meet the requirements of the Contract Drawings. The Contractor shall provide to the Construction Manager the application speed of the equipment during the time of the sample.
 2. Reflective Media: When required by the Construction Manager, the Contractor shall demonstrate to the Construction Manager the proper calibration of wet reflective bonded core elements and glass beads and compare it to manufacturer's requirements. The demonstration may be conducted by one of the following two methods.
 - a. Pressurized Delivery Systems: The calibration shall be conducted with a graduated cylinder or other similar device. Wet reflective bonded core elements or glass beads shall be collected from the reflective element and glass bead guns for a timed period. The volume of the reflective elements and glass beads shall be measured and compared with the manufacturer's requirements.
 - b. Non-pressurized Delivery Systems: The calibration shall be conducted with catch pans of known geometry, sufficiently wide to capture the width of the drop. The pans shall be positioned in the marking application path on the pavement surface. Then, separately for each glass spheres and wet reflective bonded core elements, with the thermoplastic applicator off, the applicator shall be passed over the catch pan at the appropriate speed and drop rate. The catch shall then be weighed and the drop area shall be calculated from the length of the pan and the width of the drop. Drop rate = drop capture weight / ((drop width) X (drop length)).
 3. Application Panel: The Contractor shall furnish to the Construction Manager at least one representative sample coated onto an aluminum panel or equivalent. This panel will serve as a record of the Work output and application conditions and settings.
- C. At any time throughout the duration of the Contract, the Construction Manager may request the following tests to verify application to the parameters required in this Section.
1. Specific Gravity: Test thermoplastic according to ASTM D 153. The thermoplastic sample shall have a specific gravity of a minimum of no less than 1.9 or a maximum of no more than 2.3.

2. Water Absorption: Test thermoplastic according to ASTM D 570. The thermoplastic sample shall have a maximum of 0.5 percent water absorption.
3. Ultra Violet Light and Condensate Exposure: Make samples of thermoplastic and test according to ASTM G 154. After 300 hours exposure the thermoplastic samples shall meet the requirements specified in Paragraph 2.06.F.

3.04 CONTRACT CLOSEOUT

- A. Provide in accordance with Section 017700.

END OF SECTION 340113

SECTION 344116 - TRAFFIC CONTROL EQUIPMENT

PART 1 - GENERAL

1.01 SUMMARY

- A. This Section specifies requirements for the following:
 - 1. Plywood sign panels for use in temporary pedestrian, bicycle, and vehicular guide, warning and regulatory roadway signs. Sign type usage is shown on the Contract Drawings.
 - 2. Wood sign posts and footings for sign panel side-of-road installations.

1.02 PAYMENT

- A. No separate payment shall be made for performing any Work required under this Section. All costs for Work required by this Section shall be included in the applicable lump sum(s), unit price(s), or allowance(s) as set forth in Section 012901.

1.03 REFERENCES

- A. American Association of State Highway and Transportation Officials (AASHTO):
 - 1. LTS-5-I2: Specifications for Structural Supports for Highway Signs, Luminaries, and Traffic Signals.
 - 2. MASH: Manual for Assessing Safety Hardware.
 - 3. AASHTO M 133: Specification for Preservatives and Pressure Treatment Processes for Timber.
 - 4. AASHTO M 168: Specification for Wood Products.
- B. American National Standards Institute (ANSI) / American Society of Mechanical Engineers (ASME):
 - 1. ANSI/ASME B18.2.1: Square, Hex, Heavy Hex, and Askew Head Bolts and Hex, Heavy Hex, Hex Flange, Lobed Head, and Lag Screws (Inch Series).
 - 2. ANSI/ASME B18.2.2: Nuts for General Applications: Machine Screw Nuts, Hex, Square, Hex Flange, and Coupling Nuts (Inch Series).
 - 3. ANSI/ASME B1.13: Metric Screw Threads: M Profile.
- C. American Society for Testing and Materials (ASTM International):

1. ASTM A 153: Specification for Zinc Coating (Hot Dip) on Iron and Steel Hardware.
 2. ASTM A 325: Specification for Structural Bolts, Steel, Heat Treated, 120/105 ksi Minimum Tensile Strength.
 3. ASTM A 490: Specification for Structural Bolts, Alloy Steel, Heat Treated, 150 ksi Minimum Tensile Strength.
 4. ASTM B 209: Specification for Aluminum and Aluminum-Alloy Sheet and Plate.
 5. ASTM B 211: Specification for Aluminum and Aluminum-Alloy Bar, Rod, and Wire.
 6. ASTM B 221: Specification for Aluminum and Aluminum-Alloy Extruded Bars, Rods, Wire, Profiles, and Tubes.
 7. ASTM D 245: Practice for Establishing Structural Grades and Related Allowable Properties for Visually Graded Lumber.
 8. ASTM D 2555: Practice for Establishing Clear Wood Strength Values.
 9. ASTM D 4956: Specification for Retroreflective Sheeting for Traffic Control.
- D. American Traffic Safety Services Association (ATSSA):
1. Guidelines: Quality Guidelines for Temporary Traffic Control Devices and Features.
- E. American Wood Protection Association (AWPA):
1. AWPA U1: Use Category System: User Specification for Treated Wood.
- F. Federal Highway Administration (FHWA):
1. MUTCD: Manual on Uniform Traffic Control Devices for Streets and Highways.
 2. SHS: Standard Highway Signs Including Pavement Markings and Standard Alphabets.
- G. US Department of Commerce (DOC) and National Institute of Standards and Technology (NIST):
1. Voluntary Product: Structural Plywood.
 2. Standard PS 1.

1.04 RELATED SECTIONS

- A. General Conditions Article 4.7 – Shop Drawings and Other Submittals.
- B. Section 012901 – Measurement and Payment.
- C. Section 011433 - Work in Rights-of-Way.
- D. Section 016100 - Control of Materials.
- E. Section 017700 – Contract Closeout

1.05 DESIGN AND PERFORMANCE REQUIREMENTS

- A. Design of signs and sign structure shall provide sufficient strength to withstand the wind loading generated by a basic wind speed of 120 miles per hour as per AASHTO LTS-5-12.
- B. Sign supports and framing shall be designed to meet the required wind loading. Posts shall be designed for direct embedment in the soil by excavation and backfill, or by driving with hand or mechanical equipment.

1.06 QUALITY ASSURANCE

- A. Each plywood sheet shall be grade marked and certified in accordance with NIST PS 1.
- B. Temporary signs will be evaluated by the Construction Manager for acceptability in accordance with ATSSA's Quality Guidelines for Temporary Traffic Control Devices and Features.
- C. Temporary sign supports shall conform to the requirements of the FHWA's MUTCD and AASHTO's MASH.

1.07 DELIVERY, STORAGE, AND HANDLING

- A. Refer to Section 016100
- B. All sign components and materials shall be transported and handled in a manner that shall cause no permanent deformation, injury or damage. Store sign components and materials above ground.
- C. When not in service, temporary signs and portable temporary sign supports shall be stored in such a manner and location that they do not interfere with or present a hazard to vehicular, bicycle or pedestrian traffic. No signs or supports shall be stored on the traveled way or sidewalk during non-working hours. Portable temporary sign supports stored on the roadside within the roadside recovery area, or any area that may be traversable by an errant vehicle, shall be laid flat such that no part of the support is more than 4 inches above the ground. No sign supports shall be leaned against or overhang the

traffic side of traffic barriers. The faces of stored signs shall not be visible to traffic in any direction, regardless of the orientation of the sign.

1.08 SUBMITTALS

- A. The following items are to be submitted in accordance with General Conditions Article 4.7.
- B. Traffic Control Plan: Should the Contractor propose a different traffic control plan than that included in the Plans, Contractor shall submit its plan for review and approval by the Architect/Engineer and the municipalities of Hoboken, Jersey City and Weehawken.
- C. Shop Drawings: Detailed sign face layout for all sign panels showing letter height, width, colors, spacing between letters, words, symbols and lines, border width, symbols details, and overall dimensions of the sign panels.
 - 1. Shop drawings of sign panel and posts showing the sizes of the members and their connection details. Also show the total length of the posts for each sign and show an elevation view of each of the signs as erected with vertical clearance below the lowest sign panel to adjacent roadway and other relevant dimensions.
- D. Catalog Cuts: Catalog cuts of all materials used for sign faces.
- E. Calculations: Prior to fabrication, submit computation for the design of sign panels and supports, as required in Paragraph 1.04 DESIGN AND PERFORMANCE REQUIREMENTS, signed by a Professional Engineer licensed in the State of New Jersey.

PART 2 - PRODUCTS

2.01 MATERIALS

- A. Plywood Sign Panels
 - 1. Plywood sign panels shall be flat and shall not be bowed or warped and shall conform to NIST PS 1.
 - 2. Plywood panels for temporary signs shall be exterior-type plywood with a medium density overlay, 5-ply and A-C grade or better.
 - 3. Thickness of plywood sign panels and plywood battens shall be not less than 1/2 inch. Backs and edges of temporary plywood sign panels shall be painted white.
- B. Retroreflective Sheeting

1. Retroreflective sheeting shall be colored, flexible, weather resistant and shall have a smooth outer surface. If the retroreflective sheeting contains spherical lens elements, the lens elements shall be embedded within a transparent plastic, to produce a smooth, flat outer surface. All sheeting shall be of uniform appearance, free from ragged edges, cracks, scales, blisters or other defects.
2. Prepare the surface of the sign panels for the application of the retroreflective sheeting in strict accordance with the recommendations of the manufacturer of the retroreflective sheeting.
3. Retroreflective sheeting shall be one of the following ASTM D 4956 types, as shown on the Contract Drawings:
 - a. ASTM Type I: A medium-intensity reflective sheeting also known as engineer grade. Use for pedestrian signs, except where high reflectivity is required, as shown on the Contract Drawings.
 - b. ASTM Type III: A high-intensity reflective sheeting also known as high intensity. Use for pedestrian signs, temporary delineators and other work zone devices with the exception of vehicular and bicycle construction signs.
 - c. ASTM Type IX: A very-high-intensity retroreflective sheeting having highest retroreflective characteristics at short road distances. Use for bicycle and pedestrian signs, temporary vehicle construction signs, delineators, construction zone devices and vertical panels.
 - d. ASTM Type XI: A full cube prismatic retroreflective sheeting with highest level of retroreflective characteristics. Use for permanent vehicular, pedestrian and bicycle signs.
4. Comply with sign design standards in the FHWA's MUTCD, including standards for retroreflectivity, illumination and color.

C. Wood Sign Posts

1. Signs posts shall be constructed and installed in accordance with the FHWA's MUTCD and AASHTO's LTS-5-I2.
2. Wood sign posts shall be dry, No. 1 grade, S4S, Douglas Fir, Southern or Ponderosa Pine, Hemlock, Spruce or Western Larch conforming to the applicable requirements of AASHTO M 168. The posts shall be straight and true, free of splits, knots and warps or of steel or aluminum components.
3. All wooden posts shall be treated in accordance with the applicable requirements of AASHTO M 133 and AWP A U1.

4. Posts shall be surfaced four sides, have a uniform cross-section, and shall be sized not less than 4 inches by 4 inches. The post shall be graded for the following stress grades in accordance with the grading rules developed from ASTM D 245 for the selected stress grades. Using the clear wood properties of ASTM D 2555, the bending stress of the post shall be not less than 1200 psi.
5. All 4 by 6 inch posts shall have two 1-1/2 inch diameter breakaway holes drilled through the center of the post parallel to the sign face 4 inches and 18 inches above grade and filled with flexible sealant. All 6 by 8-inch posts shall have two (2) 3-inch diameter breakaway holes drilled through the center of the post parallel to the sign face 4 inches and 18 inches above grade and filled with flexible sealant.

D. Stiffeners, Brackets and Miscellaneous Hardware

1. Horizontal and vertical sign panel stiffeners (Z bars) and panel brackets shall be fabricated of aluminum Alloy 6061-T6 conforming to ASTM B 221.
2. Other miscellaneous aluminum hardware including bolts, nuts, washers, screws, rivets, pull-type lockbolts and serrated or knob stem blind rivets shall be fabricated to meet the requirements of ASTM B 209 and ASTM B 211 for Alloy 2024-T4 with No. 205 Alumilite Finish. Ensure that bolt heads and nuts are American National Standard, Regular Series, hexagonal, semi-finished, conforming to ANSI/ASME B18.2.1 and B18.2.2, and that threads are American National Standard, Coarse Series, Class 2 Fit, conforming to ANSI/ASME B1.13. Finish bolts with an anodic coating thickness of not less than 0.0002 inches and chromate seal. Use washers conforming to ASTM B 209, Alloy 2024-T3.
3. High strength steel bolts, nuts and washers used in steel-to-steel connections shall conform to ASTM A 325 or ASTM A 490. High-strength bolts, nuts and washers shall be galvanized in accordance with ASTM A 153. Steel bolts, nuts and washers used in contact with aluminum shall be coated with cadmium or a cadmium/tin combination. All cadmium and cadmium/tin coatings shall be given a chromate treatment in or with an aqueous solution of salts, acids or both to produce a protective chromate coating.

E. Footings

1. Soil bearing plates shall be attached at the bottom of the post as required in Paragraph 1.04 DESIGN AND PERFORMANCE REQUIREMENTS, or as otherwise shown on the Contract Drawings.
2. Breakaway posts, if required, shall be as shown on the Contract Drawings. Breakaway posts and footings shall be designed in accordance with the requirements of Paragraph 1.04 DESIGN AND PERFORMANCE REQUIREMENTS, as described in Paragraph 2.01.C.4, or as otherwise shown on the Contract Drawings.

3. Concrete footings, if required by Paragraph 1.04 DESIGN AND PERFORMANCE REQUIREMENTS, shall conform to Paragraph 2.01.F Concrete.
4. Portable sign supports shall be as specified in "Maintenance of Traffic and Work Area Protection" of Division 1 - General Provisions.

F. Concrete

1. All concrete footings for sign construction, as required by Paragraph 1.04 DESIGN AND PERFORMANCE REQUIREMENTS, shall conform to the requirements of Division 3 Section on concrete.

2.02 CONSTRUCTION FEATURES

- A. Sign face text, symbol and border layouts shall be as shown on the Contract Drawings and shall conform to the requirements of the FHWA's MUTCD.
- B. Sign characters shall be as shown on the Contract Drawings, or if not shown, shall be in accordance with the FHWA's SHS, and shall include letters, numerals, symbols and borders.
- C. Sign corner and border radii shall be as shown in the FHWA's SHS. If not shown in the SHS, sign corner and border radii shall be approximately one-eighth of the height of the sign but shall not exceed 12 inches. Sign borders shall be as shown in the FHWA's SHS. If not shown in the SHS, sign borders shall be of the same type character as the legend and shall be approximately the same width as the stroke width of the major lettering on the sign.

2.03 FABRICATION

- A. Holes shall be drilled; cut edges shall be smooth and true, and free from burrs or ragged breaks. All fabrication except for cutting the lower ends of embedded posts shall be done in the shop. The plywood panels shall be clean, dry, and free from oils, dust, grit or any other contaminants that would adversely affect the adhesion of the retroreflective sheeting.
- B. In preparing sign panels for retroreflective sheeting, the entire Grade A surface to be covered shall be wiped down with a tack cloth to remove all saw dust and sanding residue.
- C. All panel and batten surfaces to be glued shall be slightly roughened and then glued with waterproof adhesive prior to assembly.
- D. After panel preparation, the edges and back or rear surface of all sign panels and battens shall be painted with two (2) coats of approved white exterior paint.

PART 3 - EXECUTION

3.01 INSTALLATION

- A. Erect and remove signs as shown on the Contract Drawings, or as ordered by the Construction Manager, and in such a manner that the traveling public is informed and protected at all times.
- B. Side-of-road ground mounted signs shall normally be erected so that the sign face is truly vertical to the profile line, and so the intersection angle measured between the sign face and the centerline of the travel lane which the sign serves is 93 degrees. Where lanes divide or curve, sign faces shall be oriented to be most effective both day and night, and to avoid the possibility of specular reflection.
- C. Wood sign posts for side-of-road mounting shall be embedded in the soil to the depth in accordance with the design requirements in Paragraph 1.04 DESIGN AND PERFORMANCE REQUIREMENTS. The hole for the embedment shall be excavated using a manual post-hole digger or appropriately sized power driven auger. After the hole has been excavated, align the post to the sign face direction, hold vertical in the hole, and tamp suitable excavated material in the annular space. Holes resulting from sign post removals shall be filled with suitable material to restore the areas to their original states as directed by the Construction Manager.
- D. Securely fasten all signs to their supports with bolts, nuts and washers of aluminum (2024-T4 alloy) or hot-dip galvanized steel in accordance with Paragraph 2.01.D Stiffeners, Brackets, and Miscellaneous Hardware and in accordance with the design requirements in Paragraph 1.04 DESIGN AND PERFORMANCE REQUIREMENTS.
- E. Use plywood battens and aluminum panel stiffeners as required by Paragraph 1.04 DESIGN AND PERFORMANCE REQUIREMENTS and in conformance with the applicable requirements of Paragraph 2.01 MATERIALS.
- F. Horizontal and vertical sign clearances shall be as shown on the Contract Drawings.
- G. Other non-wood post mounting of plywood signs, such as overhead sign installations, shall be as shown on the Contract Drawings and as specified in 1.04 DESIGN AND PERFORMANCE REQUIREMENTS and Paragraph 1.05 QUALITY ASSURANCE.
- H. Concrete footings, if required by 1.04 DESIGN AND PERFORMANCE REQUIREMENTS, shall be placed in accordance with the requirements of Division 3 Section on concrete, and shall not extend more than 4 inches above grade.

3.02 FIELD QUALITY CONTROL

- A. Field Inspections

1. Immediately prior to erection, all material will be inspected by the Construction Manager for damage that is attributable to improper transportation, handling, or storage procedures.
2. The Construction Manager will conduct an inspection of each completely erected sign in the daylight and at night for proper location, line and grade of signs, vertical post alignment, condition, appearance, reflectorization, and visibility.
3. As the Work progresses, the location, position and condition of all signs shall be monitored by Contractor in accordance with the requirements of Section 011433.

3.03 CONTRACT CLOSEOUT

- A. Provide in accordance with Section 017700.

END OF SECTION 344116

NO TEXT ON THIS PAGE

SECTION 347113 - VEHICLE TRAFFIC BARRIERS

PART 1 - GENERAL

1.01 SUMMARY

- A. This Section specifies requirements for temporary traffic barriers.
- B. Coordinate the Work of this Section with the requirements of the Contract Documents.
- C. Materials and constructions of this Section constitute temporary facilities that are and shall remain the property of the Contractor unless otherwise shown on the Contract Drawings.

1.02 PAYMENT

- A. No separate payment shall be made for performing any Work required under this Section. All costs for Work required by this Section shall be included in the applicable lump sum(s), unit price(s), or allowance(s) as set forth in Section 012901.

1.03 REFERENCES

- A. American Society for Testing and Materials (ASTM):
 - 1. ASTM A 36: Structural Steel.
 - 2. ASTM A 123: Zinc (Hot-Dip Galvanized) Coatings on Iron and Steel Products.
 - 3. ASTM A 307: Carbon Steel Externally Threaded Standard Fasteners.
 - 4. ASTM D 1751: Preformed Expansion Joint Fillers for Concrete Paving and Structural Construction (Non-extruding and Resilient Bituminous Types).
- B. West Coast Lumber Inspection Bureau (WCLIB):
 - 1. Standard Grading Rules.

1.04 RELATED SECTIONS

- A. General Conditions Article 4.7 – Shop Drawings and Other Submittals.
- B. Section 012901 – Measurement and Payment.
- C. Section 011433 - Work in Rights-of-Way.
- D. Section 016100 - Control of Materials.

- E. Section 017700 – Contract Closeout.

1.05 SUBMITTALS

- A. Submit the following items in accordance with General Conditions Article 4.7.
- B. Submit shop drawings of concrete barriers, including details of vertical joint connections, and details of proposed method of relocating concrete barriers.

PART 2 - PRODUCTS

2.01 MATERIALS

- A. Provide new materials or, if acceptable to the Construction Manager, undamaged previously used materials in serviceable condition conforming to requirements specified in this Section. Provide materials suitable for the use intended.
- B. Precast Concrete Barriers
 - 1. White Portland cement proportioned to produce 3000 psi reinforced concrete.
 - 2. Joint fillers shall conform to ASTM D 1751.
- C. Timber Barriers and Curbs
 - 1. Lumber:
Douglas Fir or Hem-Fir, WCLIB Standard Grade, dressed on four (4) sides (S4S).
 - 2. Penetrating Sealer:
Transparent colorless wood sealer which is effective in retarding transmission of moisture at crossgrain cuts and which shall not interfere with paint finish.
 - 3. Paint Finish:
Exterior alkyd resin reflectorized paint in colors shown on the Contract Drawings.
- D. Connector, Anchors, Accessories: Fabricated ASTM A 36 shapes, plates and bars welded into assemblies required, with ASTM A 307 steel bolts, lag bolts and other fasteners as required. Finish each assembly and fastener with ASTM A 123 hot-dip zinc coating.
- E. Concrete Barrier Flags: Aluminum, 6 x 6 inch, with weather resistant reflective silver sheet suitable for daylight and night hours.
- F. Concrete Barrier Lights: High intensity flashers of type specified in the Contract Documents.

- G. Timber Barrier Markers: LightRetro-Rreflective markers as shown on the Contract Drawings.

2.02 CONSTRUCTION FEATURES

- A. Fabricate exposed traffic approach end of barriers with a gradual taper with no blunt ends, arranged to redirect the path of a vehicle parallel to the line of normal traffic flow.
- B. Fabricate concrete barriers with a cross section of a portable, concrete safety shape barrier as shown on the Contract Drawings.
 - 1. Fabricate in lengths of 20 feet or less with the rectangular footing cut out at regular intervals to ensure storm water runoff.
 - 2. Furnish connections at vertical joints that will develop the full strength of the barrier system and ensure that the individual elements are aligned to provide a smooth, continuous barrier face.
 - 3. Provide barrier lights as shown on the Contract Drawings.
- C. Fabricate timber barriers and curbs of type and size shown on the Contract Drawings. Paint as shown on the Contract Drawings, or if not shown, paint white with rails of alternating orange and white stripes that slope down toward the side on which traffic is to pass. All paint shall be reflectorized.

PART 3 - EXECUTION

3.01 PREPARATION

- A. Provide and place temporary traffic control devices in accordance with the requirements of the Contract Documents.

3.02 INSTALLATION

- A. Install barriers and curbs at locations shown on the Contract Drawings.
- B. Provide bituminous pavement shimming and leveling as required to ensure smooth, continuously aligned barriers and curbs.
- C. Provide 1/2-inch-wide joints between ends of barriers and curbs. At concrete barriers, fill joint with premolded bituminous joint filler.
- D. Secure barriers against lateral displacement by use of drift pins or anchor bolts drilled into roadway surface.

- E. Connect, and continuously operate, concrete barrier lights.

3.03 ADJUSTMENTS

- A. Maintain, clean, relocate and replace barriers and curbs as required to protect motorists, pedestrians and workers throughout the Work of this Contract.
- B. Remove barriers away from public ROW, public easements and private easements, when the need has ended, when replaced by approved use of permanent construction, or when directed by the Construction Manager.
- C. Complete, or if necessary, restore permanent construction. Replace construction that cannot be satisfactorily repaired. Remove temporary paving that is not intended for or acceptable for integration into permanent paving.

3.04 CONTRACT CLOSEOUT

- A. Provide in accordance with Section 017700.

END OF SECTION 347113

SECTION 347120 - BEAM GUIDE RAIL

PART 1 - GENERAL

1.01 SUMMARY

- A. This Section specifies requirements for resetting beam guide rail.
- B. Coordinate the Work of this Section with the requirements of the Contract Documents.

1.02 PAYMENT

- A. No separate payment shall be made for performing any Work required under this Section. All costs for Work required by this Section shall be included in the applicable lump sum(s), unit price(s), or allowance(s) as set forth in Section 012901.

1.03 REFERENCES

- A. American Society for Testing and Materials (ASTM):
 - 1. ASTM A 36: Structural Steel.
 - 2. ASTM A 123: Zinc (Hot-Dip Galvanized) Coatings on Iron and Steel Products.
 - 3. ASTM A 709: Standard Specification for Structural Steel for Bridges.
- B. American Association of State Highway and Transportation Officials (AASHTO):
 - 1. M180: Standard Specification for Corrugated Sheet Steel Beams for Highway Guardrail.
- C. New Jersey Department of Transportation (NJDOT):
 - 1. NJDOT Standard Specifications for Road and Bridge Construction, current edition.

1.04 RELATED SECTIONS

- A. General Conditions Article 4.7 – Shop Drawings and Other Submittals.
- B. Section 012901 – Measurement and Payment.
- C. Section 017423 – Cleaning Up.
- D. Section 017700 – Contract Closeout.
- E. Section 033000 – Cast-in-Place Concrete.

1.05 SUBMITTALS

- A. Refer to General Conditions Article 4.7
- B. Submit shop drawings of beam guide rail in accordance with the requirements of General Conditions Article 4.7.

PART 2 - PRODUCTS

2.01 MATERIALS

- A. If acceptable to the Construction Manager after examination of removed beam guide rail, utilize undamaged previously used materials in serviceable condition conforming to requirements specified in NJDOT Standard Specification Section 609.02, otherwise provide new materials, as specified in NJDOT Standard Specification Section 609.02. Provide materials suitable for the use intended.
- B. Miscellaneous Hardware: Provide connections or splices, nuts, bolts, washers, and plates conforming to AASHTO M 180.

PART 3 - EXECUTION

3.01 PREPARATION

- A. Provide and place temporary traffic control devices in accordance with the requirements of the Contract Documents.
- B. Remove beam guide rail as specified in NJDOT Section 609.03.06.
- C. When the Construction Manager determines that the beam guide rail is suitable for resetting, dismantle, store, and protect the components until resetting as specified in NJDOT Section 609.03.05.
- D. After removing beam guide rail, backfill the post holes and compact the area to the elevation of the adjacent surface. Dispose of unsalvageable beam guide rail components as specified in Section 017423.

3.02 INSTALLATION

- A. Install beam guide rail at locations shown on the Contract Drawings, and as specified in NJDOT Section 609.03.05 and shown in the Construction Details.

3.03 CONTRACT CLOSEOUT

- A. Provide in accordance with Section 017700.

END OF SECTION 347120

NO TEXT ON THIS PAGE

SECTION 353130 – ROLLING GATES AND APPURTENANCES

PART 1 - GENERAL

1.01 SUMMARY

A. Introduction

1. The Contract documents provide a preliminary design of the flood gates. The Contractor will be required to provide detailed design and calculations to the Architect/Engineer for review and approval prior to fabrication.

B. Work included

1. Preparing and submitting detailed shop and installation drawings including detailed calculations and final design of the gates for the Architect/Engineer's review as required in General Conditions Article 4.7.
2. Provide and install all rolling gates and appurtenances included in the Contract Drawings, including the wheels, seals, bearing bars, latches, guides, stabilizing devices, supports, intermediate posts, embedded runway and sealing surfaces, all operation mode accessories and other auxiliary parts needed for a complete installation;
3. Packaging and transportation of the gates and appurtenances to the project site including all handling, permits and temporary storage of the gates;
4. All labor and equipment needed for the installation of the gates and appurtenances;
5. Preparing and submitting the operation and maintenance manual as required in Section 017823 and General Conditions Article 8.2;
6. Shop testing of the gates prior to delivery to the site;
7. Provide permanent electric winches as indicated on the Contract Drawings. The winch support structures and electrical systems and utility connections are included;
8. Supply two (2) portable backup winches. Each winch shall have the capacity to move the largest of the gates.
9. Supply two (2) portable gasoline generators sized to provide the power required to operate the largest motorized winch.

10. Supply spare parts for each gate recommended by the gate manufacturer and approved by the Architect/Engineer.
11. Contractor to provide a recommendation for a class of maintenance vehicle sized to manage (open/close the gate using a mounted winch) the weight of the largest gate without any alternate anchorage or support. The vehicle will at a minimum be fitted with the following equipment;
 - a. Hydraulic power take off (PTO) to operate winch, crane and other equipment.
 - b. Vehicle mounted winch, sized to operate the largest gate.
 - c. Vehicle mounted crane or hoist to assist with the installation of intermediate posts, stabilizers and other gate equipment.
 - d. Mount for portable generator.
 - e. Vehicle mounted tool or equipment boxes to store tools, cords, cables and other equipment needed to deploy or maintain the gates.
12. Supply two enclosures' safety doors. The Contractor shall provide one safety door per gate enclosure (gates NG-7 and NG-8);
13. Grounding connections for the electrical systems;
14. Site testing and commissioning;
15. Services of the gate manufacturer's representative to assist the Contractor in the installation, testing and commissioning of the gates.
16. Providing the O&M training to be conducted by the gate manufacturer's representative and include classroom and field training. Training is to be recorded in accordance with General Conditions Article 8.3. Training materials, handouts and agenda to be submitted to the Architect/Engineer for review and approval at least one month prior to any training.

1.02 PAYMENT

- A. All costs for Work required by this Section shall be included in the applicable lump sum(s), as set forth in Section 012901.

1.03 RELATED SECTIONS

- A. General Conditions Article 4.7 – Shop Drawings and Other Submittals
- B. General Conditions Article 8.2 – Operations, Equipment and Maintenance Manuals

- C. General Conditions Article 8.3 - Training
 - D. Section 012901 – Measurement and Payment
 - E. Section 014300 – Quality Requirements
 - F. Section 016100 - Control of Materials
 - G. Section 017700 – Contract Closeout
 - H. Section 017823 - Operations and Maintenance Manual.
 - I. Section 031000 – Concrete Formwork.
 - J. Section 033000 – Cast-in-Place Concrete.
 - K. Section 051200 - Structural Steel.
 - L. Section 055000 - Miscellaneous Metal.
 - M. Section 099110 - Shop Painting.
 - N. Section 260526 - Grounding and Bonding for Electrical Systems.
 - O. Section 260533 - Conduits and Junction Boxes.
 - P. Section 262000 - Electric Winch Motors.
 - Q. Section 262416 - Panelboards.
 - R. Section 262717 - Winch Control Panel and Pendant Panel.
 - S. Section 263213 – Portable Generator.
 - T. Section 263613 - Non-Automatic Transfer Switches.
- 1.04 DEFINITIONS
- A. Exterior side: The exterior side of the gates or Resist Structure is the unprotected or flood side.
 - B. Gate Slab: The gate slab is located under the gate and expands on each sides of the gate. The gate sill embedded parts are integrated into this slab. The gate slab transfer loads from the gate to the ground, such as dead load and hydrostatic load transferred from the intermediate posts of the longer gates. This slab is provided by the Contractor.

- C. Interior Side: The interior side of the gates or Resist Structure is the protected side against flood.
- D. Monolith: The Resist Structure vertical pilasters.
- E. Seal Preset: The extent the seal stem should be placed under deflection. The preset cause initial seal compression on the seal plate without water pressure.
- F. Hold Point: During the manufacturing in the workshops, the Construction Manager is invited for a hold point with a minimal two (2) weeks' notice. During the field work on site, the Construction Manager is invited for a hold point with a minimal two (2) weeks' notice. The Contractor's Project activity affected by the hold point shall be stopped until the acceptance of the Construction Manager.
- G. Check Point: During the manufacturing in the workshops, the Construction Manager is invited for a check point with a minimal two (2) weeks' notice. During the field work on site, the Construction Manager is invited for a check point with a minimal two (2) weeks' notice. The Construction Manager may decide to attend or not to a check point. A check point does not stop any of the Contractor's Project activities.

1.05 CODES, STANDARDS AND OTHER PUBLICATIONS

- A. All gates shall be structural parts of the Resist Structure during operation and design according to sound engineering practice, as per USACE & FEMA 44 CFR 65.10(b)(2).
- B. For any discrepancy related to the rolling gate design, the documents would supersede on another in the following order: the Codes, this Section, the Contract Drawings, the USACE publications and the other standards and publications.
- C. If no year is indicated, the most up to date version of codes, standards and other publications shall be used.
- D. The publications listed below form a part of this Section.
 - 1. AISC – Codes, Specifications, Design Manuals and Steel Construction Manual;
 - 2. ASME B30.7 – Winches;
 - 3. ASME Structural Welding Code Section IX;
 - 4. AWS-D1, D1.2, D1.3 & D1.6 – Structural Welding Code;
 - 5. USACE ETL 1110-2-584 – Design of Hydraulic Steel Structures;
 - 6. USACE EM 1110-2-2104 – Strength Design for Reinforced Concrete Hydraulic Structures;

7. OSHA Regulations and standards.
- E. The publications listed below form a part of this Specification to the extent referenced. The publications are referred to within the text by the basic designation only.
1. ASCE 7-10 – Minimum Design Loads for Buildings and Other Structures;
 2. International Code Council (ICC), International Building Code, New-Jersey Edition.
 3. ASTM INTERNATIONAL (ASTM)
 - a. ASTM D 395 Standard Test Methods for Rubber Property - Compression Set.
 - b. ASTM D 412 Standard Test Methods for Vulcanized Rubber and Thermoplastic Elastomers – Tension.
 - c. ASTM D 471 Standard Test Method for Rubber Property - Effect of Liquids.
 - d. ASTM D 572 Rubber Deterioration by Heat and Oxygen.
 - e. ASTM D 2240 Standard Test Method for Rubber Property - Durometer Hardness.

1.06 SUBMITTALS

- A. Project Submittals
1. Submit the following items in accordance with General Conditions Article 4.7. Documents signed and sealed by a New Jersey Professional Engineer will only be reviewed and evaluated for design approach and completeness.
 - a. The Contractor shall prepare and submit for the review and evaluation of the Architect/Engineer: document register / plan, quality control and assurance plans, detailed schedule, general arrangement drawings, detailed calculations, technical data sheets, shop test procedures, installation procedures and commissioning test procedures. Drawings and calculations are to be signed and sealed by a New Jersey Professional Engineer.
 - b. The Contractor shall prepare and submit for evaluation by the Architect/Engineer: complete shop and assembly drawings and descriptive literature showing details of the rolling gate required as indicated herein and on the Contract Drawings. Shop drawings shall indicate computed weights of the gate structure and components. Drawings and calculations are to be signed and sealed by a New Jersey Professional Engineer. Drawings shall also include, but not limited to:

- (1) a detailed list including all components, parts or equipment to be purchased, with the same specifications that appear on the order forms of the gates and appurtenances.
 - (2) the specification of materials;
 - (3) welding symbols;
 - (4) machining instructions;
 - (5) all tolerances and requirements for flatness, parallelism, orthogonality, hardness and surface finish;
 - (6) heat treatments;
 - (7) non-destructive testing;
 - (8) bolt tightening instructions;
 - (9) painting instructions or any other corrosion protection system.
 - c. Contractor shall allow a minimum of 3 weeks for approval of shop drawings, calculations and other submittals.
 - d. Field Assembly – if any of the gates are to be assembled at the project site following delivery, the Contractor shall submit detailed work methods including the following:
 - (1) Area needed for assembly
 - (2) Equipment and tools needed to assemble the gate sections.
 - (3) Information on parts needed to assure watertight assembly
 - (4) Approximate time needed to assemble the gate sections into a complete gate.
2. Operations and Maintenance Manual Submittals
- a. Refer to General Conditions Article 8.2
 - b. Detailed operation and maintenance manual that shall include, but not limited to, the following technical elements:
 - (1) a table of contents;
 - (2) a complete drawings list;

- (3) a table summarizing the technical specifications of the components;
- (4) a detailed description of the operation procedures of the equipment including deployment time;
- (5) a list of preventive maintenance and inspections including the frequency of inspections and maintenance operations;
- (6) a troubleshooting section;
- (7) lubrication instructions, with a table summarizing the points to be lubricated, the type of lubricants and the lubrication frequency;
- (8) the list of spare parts;
- (9) a detailed description of all components with assembly, adjustment and maintenance instructions;
- (10) a copy of the purchase orders for all the components;
- (11) a scaled 11x17 copy of all the drawings of assemblies and subassemblies

1.07 QUALITY CONTROL

- A. Comply with the requirements of Section 014300.
- B. General: The Contractor is fully responsible for ensuring compliance with all tolerances required to achieve the performances included in the Contract Documents. The Contractor shall also establish and maintain quality control for rolling gate operations to ensure compliance with Contract Documents and maintain records of his quality control for all construction operations including, but not limited to, the following:
 1. Ensure timely submittal of shop drawings.
 2. Inspection on delivery of fabricated items for damage, defects, and conformance with approved shop drawings.
 3. Installation in conformance with manufacturer's recommendation and contract requirements.
- C. Reporting: The original and two (2) copies of these records and tests, as well as corrective action taken, shall be furnished to the Construction Manager daily. Format of the report shall be agreed with the Construction Manager before submission.

- D. Quality Plan: The Contractor shall submit for approval his detailed quality plan (as per Section 014300). The quality plan shall include descriptions of inspections and tests to be performed during the manufacturing, installation and commissioning.

The quality plan shall include the proposed Project hold points and check points involving the Construction Manager during the manufacturing, installation and commissioning. These Hold and Check Points shall include, as a minimum and not limited to, the following:

1. Manufacturing:

- | | |
|---|-------------|
| a. Acceptation of material mill tests certificates | Check Point |
| b. Tack welded pre-assembly dimensions inspection | Check Point |
| c. Final assembly dimensions and tolerances inspection | Hold Point |
| d. Acceptation of stress relief report before machining | Check point |
| e. Machining tolerances inspection | Hold Point |
| f. Surface preparation before coating inspection | Hold Point |
| g. Coating application inspection (including environmental parameters and film thickness in case of paint coating) | Hold point |
| h. Pre-shipping inspection and review of the manufacturing quality records, including, as a minimum and not limited to: | Hold Point |
| (1) Quantities; | |
| (2) Possible damages due to handling; | |
| (3) Latching and Protection. | |

2. Installation:

- | | |
|---|-------------|
| a. Site receiving and storage, as a minimum and not limited to: | Check Point |
| (1) Quantities; | |

(2) Possible damages due to transportation and unloading;

(3) Storage protection.

- | | |
|---|------------|
| (a) Adjustment dimensions and alignment tolerances inspection of embedded parts before concreting | Hold Point |
| (b) Alignment tolerances inspection of embedded parts after concreting | Hold Point |
| (c) Paint and galvanization touch up and cleanliness inspection | Hold point |
| (d) Commissioning tests | Hold Point |
| (e) Final acceptance inspection including review of the quality records | Hold Point |

E. Tests and Inspections:

1. Weld Testing: In addition to visual inspection, all welds shall be tested and inspected, at a minimum, according to AWS D1.1/D1.1M and the inspection procedures listed in subparagraphs below.

<u>Weld Type</u>	<u>Inspection Type</u>	<u>Proportion to be inspected</u>
Full penetration butt weld in flanges and parts in tension	Radiographic	50%
	or Ultrasonic	100%
Butt weld in flanges and parts in Compression	Radiographic	5%
	or Ultrasonic	50%
Full penetration butt weld in flanges and parts with alternating stress or dynamically stressed	Radiographic	100%
Full web penetration butt weld	Magnetoscopic or Dye Penetrant	10%
Fillet welds and partial penetration welds	Magnetoscopic or Dye Penetrant	10%

2. The Engineer reserves the right to modify the location of the inspections indicated in the above table without however exceeding the total percentage indicated for each type of weld.
3. The Contractor must indicate on his detail drawings, which shall be submitted for acceptance by the Engineer, all the critical welds that are subject to the various inspection methods mentioned above, so as to verify whether they meet the requirements of the technical specifications.
4. Unacceptable defects shall be gouged to sound metal and exposed parts after gouging shall be subjected to non-destructive examination satisfactory to the Engineer. All repair welds must be 100 percent inspected by the inspection method originally used.
5. When an inspected area reveals defects subject to repair, adjacent areas should also be inspected using the same method. If any of the adjacent areas also show unacceptable defects, the weld should be inspected in its entirety.
6. All non-destructive testing on welds shall be done in accordance with:
 - a. Dye Penetrant Inspection: ASTM E 165.
 - b. Magnetoscopic Inspection: ASTM E 709.
 - c. Radiographic Inspection: ASTM E 94.
 - d. Ultrasonic Inspection: ASTM E 164.

F. Supplemental Special Inspections and Testing:

1. The DEP may engage qualified special inspectors to perform oversight of the gate manufacturing, assembly, testing and inspections performed by the Contractor and its inspection and testing agency. The Contractor to provide testing agency access to the work as required.

1.08 WARRANTY

- A. Rolling gates shall operate in accordance with Contract requirements and be free of defects in material and workmanship for a period of not less than three (3) years from the date of final acceptance.

1.09 DELIVERY, STORAGE, AND HANDLING

- A. Conform with the requirements of Section 016100.
- B. Deliver equipment with protective crating and covering.

- C. Store equipment to prevent damage and protect from weather, dirt, fumes, water, snow, ice and construction debris until final delivery date to the construction site.
- D. All stored or unsecured parts shall be locked to ensure security and operability.

PART 2 - PRODUCTS

2.01 GATE DESIGN DESCRIPTION

- A. Rolling gates
 1. General: Rolling gates are supported by two (2) lines of main wheels.
 2. Structures: The gate structure is composed of horizontal girders, vertical intercostals, diaphragms and skin plate.
 3. Intermediate posts: As indicated on the Contract Drawings, in the closed position and in preparation for a flood event, the longer gates will be supported by intermediate posts in order to limit the gate deflection and also to reduce the loads transferred to the Resist Structure Monoliths during a flood. These devices shall be stored underground, as shown on the Contract Drawings, when the gate is in the stored position. The underground storage location of the intermediate posts shall include a drain as shown on drawings. This storage location shall be closed by a structural cover rated at AASHTO H-20 loads and be lockable with a recessed locking mechanism.
 4. Main wheels: The main wheels are supporting the dead load of the gate and allow the gate to move from the stored to the closed position. For prefabricated wheels, the load capacity shall be evaluated using the technical data sheet(s). For custom manufactured wheels, detailed calculations of the wheels need to be submitted for evaluation.
 5. The main wheels shall be mounted on the same plane so as to uniformly distribute the load on the runways.
 6. The main wheels located in between the gate supports (the monoliths and intermediate posts) shall be free to slide toward the interior side to allow for the gate deflection.
 7. The main wheels which are aligned with the gate supports (the monoliths and intermediate posts) shall be flanged to guide the gate during its movements.
 8. Stabilizing systems: The gate shall include the stabilizing systems that will ensure that the gate will remain stable in all operating condition including all loads. As shown on the Contract Drawings, the stabilizing system shall consist of upper stabilizing rollers and/or removable stabilizing rollers, as needed. The upper

stabilizing rollers transfer the loads to the concrete Resist Structure. The removable stabilizing rollers are transferring the loads to the embedded rolling paths located on both sides of the gates.

9. Bearings: All wheels and rollers shall be provided with sealed ball or roller bearings. Bearings calculation needs to be submitted for evaluation.
10. Bearing bars: The gate loads shall be transferred from the gate structure to the Resist Structure Monoliths by bearing bars. The bearing bar shall be configured to allow water pressure to increase the compression of the seal.
11. Seals: All gate seals shall be “J” type, or music note seals. To minimize friction, the seals shall not be in contact with the sealing surfaces when the gate is travelling in the storage area. When the gates are in the closed position, their seals shall be preset enough to ensure proper sealing for any flood level below the top of the gate.
12. Seals clamp bars: Seals shall be bolted on the gate with clamp bars as per the seal manufacturer’s recommendations.
13. Latching devices: The gates shall be provided with latching devices for securing the gates in the closed and stored position. The latching device shall be heavy-duty and lockable.
14. Bumpers: Gates shall be provided with bumper to stop their movement within the right alignment and to protect the other components. These bumpers shall be designed for the stall motor torque of the winch.
15. Nameplates: Gates shall be provided with nameplates. Nameplates shall be approved by the Architect/Engineer.
16. All components of the gates required to operate the gates shall be stored and locked in the gate when possible, otherwise in a cabinet in the gate storage area. All removable equipment and parts are to be stored with the gate. Storage cabinets are to be sized and compartmentalized to fit all the loose components.
17. The gate structure shall be provided with reflective warning signs as shown on the Urban Amenities Plans.

B. Embedded parts

1. General: The embedded parts are the static structures embedded into the Resist Structure Monoliths and into the gate slab. The embedded parts consist of the assembly of the runway supports, bearing bars, sealing surfaces and intermediate post brackets with their respective supports and anchors.

2. Runway: The rolling surfaces must be at the roads, walkways and top of train rail level. All runway designs must be assembled beam with stainless steel surface and shall be evaluated by the Architect/Engineer. The rolling surfaces must be sufficiently leveled so that the gate does not move by gravity.
3. Bearing bars: The bearing bars of the gate transfer the loads to the bearing bars of the Resist Structure Monoliths.
4. Side sealing surfaces: Leveled, adjusted and continuous surface that will ensure proper sealing with the gate side seals.
5. Sill sealing surfaces: Leveled, adjusted and continuous surface that will ensure proper sealing with the gate sill seals.
6. Intermediate post brackets: The intermediate braces posts transfer their loads to the brackets located on the interior side of the Gates. These brackets are anchored in the gate slab.
7. Anchors: Anchors shall be injectable adhesive type (post-installed in the concrete) and /or cast-in-place anchors and shall be approved by the Architect/Engineer. The Contractor is responsible for the installation of the anchors and their design is to rely on the concrete and rebar to resist pull out and prevent any other type of failure; the anchor design should not require adding rebar to the concrete structure design.
8. Interferences with rebar: The gate manufacturer shall coordinate his design with the Contract Drawings and with the Contractor to avoid drilling in rebar during anchors installation.
9. Concrete pouring: The gate slab consists in the first phase of concrete pouring. After their installation and alignment, the embedded parts, supports and anchors will be buried into the second concrete phase.

C. Winches

1. General: All winches shall be heavy-duty industrial type and shall be designed for operating the gates without interruption during all operating condition. All winches shall be marine duty rated with NEMA 4X enclosures and shall be designed to remain fully operable and reliable after flooding up to the top of the wall. All winches shall be fully reversible.
2. All winches shall be compliant with ASME B30.7 and shall be supplied by a winch manufacturer.
3. Control: All winches shall be supplied with a pendant and 12 foot cord. The pendant and its cord shall be stored in their own submersible electrical panel and connected to the control panel by embedded conduit.

4. Speed: The minimum winches line speed is 3 foot per minute. The maximum winches line speed is 10 feet per minute.
5. Wire ropes: All winches shall be supplied with stainless-steel wire ropes.
6. Sheaves: Wall mounted winches shall be directly connected to the gates through one sheave. Also, the gate manufacturer shall include necessary sheaves to move the gate in any direction and in any position with work truck equipped with a portable winch, as a backup operation system. The work truck shall be able to operate the gate in any position. All sheaves shall be easily removable in order to install the winch wire rope, including wire rope hardware.
7. Clutch: All winches shall be supplied with a free spooling clutch so wire rope can be quickly deployed. The maximum manual unspooling force shall be 20 pounds. Otherwise, the winch motor shall be reversible.
8. Bearings: All bearing shall be ball or roller bearings. Bushings are not accepted.
9. Guards and covers: The winches shall include safety guards. The winches shall include protective covers that will protect the winches from the weather and from vandalism when the gates will be latched in the stored position. The protective cover shall be lockable with a heavy duty padlock on one side and shall be supported on the other side by a heavy duty vandal proof hinge. Guards and covers shall be lightweight enough to be handled by one worker.
10. Nameplates: Winches shall be provided with stainless steel nameplates. Nameplates shall be approved by the Architect/Engineer.

At a minimum, the name plate shall include the following information:

- a. Brand;
- b. Model Number;
- c. Serial Number;
- d. Maximum Pulling Capacity;
- e. Speed;
- f. Motor Power Consumption;
- g. Main Voltage;
- h. Total Amperage;
- i. Frequency;

- j. Number of Phase(s);
 - k. Duty Rating (NEMA 4X)
11. Support structure: The winch support structures shall be installed in such a way that the bottom of the winch is at the top of wall level on the exterior side. The structure is to be designed to resist the weight and maximum torque of the winch and motor. The support structure shall be hot dip galvanized as per Section 055000 - Miscellaneous Metal.
 12. Each winch shall be designed to ensure adequate and equally distributed wire rope winding. An automatic wire rope guiding system can be provided to meet this requirement if necessary. The guiding system shall be heavy duty and shall not cause wire rope wear.
 13. Winch spool: Each winch spool shall be chosen according to the wire rope length while optimizing the dimensions to limit the overall size of the winch.
- D. Winch controls: One (1) control panel for each gate and shall comply with Section 262717.
- E. Electrical
1. An electrical panel board shall be provided including the following:
 - a. Electrical panel with main breaker;
 - b. Non-automatic transfer switch;
 - c. Main breaker;
 - d. Receptacle compatible to the generator connection for the emergency generator;
 - e. Metering device, the electrical panel board shall include a metering device acceptable to the Utility Company.

2.02 ALLOWABLE STRESSES AND LOADS

- A. Rolling gates and embedded parts: as per USACE ETL 1110-2-584. This design can be done with the limit state (LRFD) method or with the allowable stress design (ASD) method.
- B. Concrete and anchors: as per USACE EM 1110-2-2104.
- C. Maximum allowable stress on the concrete: 1700 PSI.

- D. Maximum allowable load on the removable stabilizing rollers: 7500 lb. per roller.

2.03 ALLOWABLE DEFLECTIONS

- A. The maximum gate girder deflection is 1/600 of the beam free span. Allowable deflection may be smaller than this value because of the sealing, the adjustment gap between wheels and rails or other detailed design criteria.
- B. The intermediate posts structural cover shall have a maximum deflection of 1/400 of the cover span with maximum vehicle load.

2.04 MINIMUM MATERIAL THICKNESS

- A. The minimum thickness of the gate structural components is 0.25 inch.
- B. The minimum thickness of the sealing surfaces plates is 0.375 inch after machining.
- C. The minimum thickness of the embedded parts is 0.25 inch.
- D. The minimum thickness of the winches protective covers is 16 gauge (0.0625 in) stainless steel.

2.05 AMBIENT CONDITIONS

- A. The gate shall be operated normally between 20 degrees F and 110 degrees F.
- B. The gates shall be fully operative below freezing point after seals and roller path deicing.
- C. The gate will be stored outside at a temperature between (-)10 degrees F and 120 degrees F.
- D. The humidity index can vary between 0 percent and 100 percent.
- E. The gates or appurtenances shall not be damaged by ambient conditions, brackish water or salt water during flooding or storage.
- F. Overtopping water caused by waves shall not cause gate operational issues such as excessive vibration and seal leaking.

2.06 LOAD CASES AND LOAD COMBINATION

- A. Loads
 1. All Gate loads: as per USACE ETL 1110-2-584.
 2. Impact loading: 500 pounds per linear foot on the full length of the upper gate girder.

3. Wind loading: as per ASCE 7-10
4. Wave loading: see Appendix A (at the end of this section)
5. Seismic loading: Shall be evaluated as per ICC), International Building Code, New-Jersey Edition and ASCE 7-10. The stability of the gate structure shall also be validated.
6. The gate system and its latching device shall be designed for wind up to 135 MPH with minimum safety factor of 2 on the yield strength of the materials. In this case, the gate is closed and there is no flood.

B. Load combination

1. The loads shall be combined in the worst possible ways to ensure that the gates will perform as expected.
2. Rolling gates and embedded parts: as per USACE ETL 1110-2-584.
3. Concrete and anchors: as per USACE EM 1110-2-2104.
4. Winches: as per ASME B30.7.

2.07 MATERIAL GRADES, TYPES, AND CLASSES

A. General:

1. Metals and steels supplied shall be new and of the highest quality and shall conform to the minimum requirements of the material specifications specified. Specifications, mill certificates, and Non-Destructive Examination (NDE) records shall be obtained for all metals and issued to the Construction Manager for the permanent record. These documents shall include, but are not limited to, heat numbers, unique item identification, chemical compositions/analysis and mechanical properties (yield and tensile strengths, elongation and Charpy V-notch impact test results).
2. Requests to use alternative equipment or materials shall be submitted per General Conditions Article 4.7.
3. Dissimilar Materials: The assembly design and installation shall ensure that:
 - a. Aluminum shall be physically separated from concrete.
 - b. Dissimilar metals shall be physically separated.

4. Before starting fabrication, Contractor shall submit to the Construction Manager the certificates of the tests executed in steel mill corresponding to the materials to be used. Refer to Section 051200 – Structural Steel for details.
 5. Castings
 - a. Castings shall adhere to the following standards:
 - (1) Carbon steel castings – ASTM A-27, Grade 70-40;
 - (2) Stainless steel castings – ASTM A-743, Grade CA-6NM.
 6. Forgings
 - a. Forgings shall adhere to the following standards:
 - (1) Carbon steel forgings – ASTM A-470 Class 4;
 - (2) Stainless steel forgings – ASTM A-182.
- B. Materials for the gate shall be as follows:
1. Gate structure: as per Section 051200.
 2. Intermediate posts: as per Section 051200.
 3. Main wheels: High Carbon Steel.
 4. Axels: ASTM A276 or A240, Type 304 or SAE Type 630 Hardened Stainless Steel;
 5. Wheel and sheaves bearings: Factory greased sealed bearing, maintenance free.
 6. Stabilizing system: as per Section 051200.
 7. Bearing bars: as per Section 051200.
 8. Seals clamp bars: ASTM A276 Type 304 Stainless steel.
 9. Latching devices: as per Section 051200.
 10. Structural Fasteners (Bolts, nuts and washers): ASTM A325 Hot-Dip Galvanized.
 11. Seals Fasteners: AISI 304, ASTM A193 Gr B8.
- C. Materials for the embedded parts shall be as follows:
1. Runway: SAE Type 630 – Hardened Stainless Steel.

2. Embedded parts: as per Section 051200.
3. Sealing Plates: ASTM A276 Type 304 Stainless steel.
4. Anchors: ASTM A325.
5. Semi-embedded Anchors: ASTM A276 Type 304 Stainless steel.

D. Materials for the winches shall be as follows:

1. Structure and supports; as per Section 051200.
2. Sheaves: AISI 1045.
3. Wire rope accessories, hardware, and connecting parts: Stainless Steel.
4. Anchors: ASTM A325.
5. Winch protective cover, padlock, and hinge: Stainless Steel.

E. Other materials:

1. Intermediate post storage covers: ASTM A276 Type 304 Stainless steel
2. Intermediate post storage frame and semi-embedded steel: ASTM A276 Type 304 Stainless steel
3. Intermediate posts and brackets: Hot Dip Galvanized steel, as per Section 051200.
4. Intermediate posts pins: ASTM A276 Type 304 Stainless steel

F. Winch Wire Rope

1. Comply with ASTM A492 and Federal Specification RR-W-410, UNS S30400 or S31600.
2. IWRC – Independent Wire Rope Core.
3. The minimum safety factor (SF) for the wire rope shall be 3:1 relatively to its breaking point.
4. Store and install wire rope as per the Wire Rope User's Manual, third edition, published by the Wire Rope Technical Board. Install without kinking. Use fittings of the same material as the rope to attach rope to structural elements.

G. Gate seals

1. Gate seals shall be molded, and the material shall be compounded of natural rubber. Seal material shall contain reinforcing carbon black, zinc oxide, accelerators, antioxidants, vulcanizing agents, and plasticizers.
2. Gate seals shall be “J” type and shall be conforming with ASTM standards including the following requirements: minimum Tensile Strength of 2.5 KSI, minimum Ultimate Elongation of 450 percent, 0.9 KSI for an Elongation of 300 percent, maximum 10 percent water absorption, minimum 80 percent of tensile strength after aging and maximum 30 percent of permanent compressive deformation.
3. All joints in seals shall be spliced by vulcanization. All holes in the gate seals shall be drilled as per manufacturer's recommendations.
4. Gate Seals shall not contain reclaimed polymers nor internal reinforcement with metal and/or canvas, natural or synthetic fiber.
5. Seals hardness shall be selected as required for the application.
6. Seals materials shall be tested as per applicable ASTM standards.

2.08 OPERATING CONDITION REQUIREMENTS

A. Gate operation

1. Maximum deployment duration per gate opening (for a five (5) trained workers crew):
 - a. 70’ and less: 60 minutes
 - b. 71’ to 100’: 90 minutes
 - c. 101’ to 140’: 120 minutes
2. The gate shall close easily during the design life.
3. The gate design shall minimize the risks (binding or wheel freezing) of pausing or stopping the gate deployment.
4. The gate shall be latched and locked in the closed position.
5. A stabilizing system shall be designed to ensure safe operation with a maximum wind speed of 40 mph (peak).
6. The gate operations shall comply with OSHA 29CFR1910 requirements.

B. Gate storage

1. The gate storage locations are shown on the Contract Drawings.
2. The gate shall be latched and locked in the stored position.
3. The gate storage footprint shall be minimized.

C. Flood Event

1. No gate components shall have to be replaced due to flooding on the exterior side of gates, except for normal wear and tear items.

D. Gate operation modes

1. Primary: Permanent electric winches using utility power.
2. Secondary; Permanent winches using backup generator power.
3. Tertiary: In the event the gates provided with permanent electric winches can't be deployed with the permanent winches, these gates shall be deployed with truck mounted portable winch. In most of the cases, the portable winch shall be pulling from the exterior side of the gates through sheaves as shown on the Contract Drawings. As shown on the Contract Drawings, in some cases the truck mounted winch shall operate the gate from the interior side. Removable sheaves shall be installed on each side of the opening and towing points shall be installed on the gate in such a way that portable winch can open and close the gate.

2.09 MAINTENANCE REQUIREMENT

- A. All components shall be easily accessible for visual inspection and maintenance and shall conform to Section 017823.
- B. All components that may be replaced due to normal wear and tear, shall be easily accessible for inspection and repair or replacement.
- C. The maintenance requirements are applicable when the gates are in the closed and stored position.
- D. Gate seals shall be easily replaceable when the gates are on their runway. Seals replacement shall not require heavy equipment to maneuver the gate.
- E. All padlocks provided for the gates shall be keyed identically, Contractor to provide a minimum of 4 sets of keys for each gate padlock.

2.10 DESIGN LIFE

- A. The gate design life shall be at least for 50 years of operation. This design life takes into consideration normal annual maintenance. The gate shall not require major rehabilitation during this design life period.

2.11 HEALTH, SAFETY AND ENVIRONMENT REQUIREMENTS

- A. Gate components shall not to contain any hazardous materials.
- B. The gates shall not cause environmental damages due to spillages such as lubricant leaks.
- C. The gate and appurtenances shall conform to the applicable OSHA 29CFR1910 regulations.

2.12 OTHER REQUIREMENTS

- A. Operating conditions
 - 1. The gate, frame and appurtenances shall be designed in a way to avoid being damaged by vehicular traffic, machinery and snow removal machinery.
- B. Sealing performance
 - 1. The gate seals leakage flow shall not exceed 0.2 gallon per minute per linear foot of seal.
- C. Removable parts
 - 1. All removable parts shall be assembled with stainless steel shaft or pin with retaining chains or anti-theft device and be stored into their assembly location.

2.13 CONTROL AND ELECTRICAL REQUIREMENTS

- A. The electrical panel board shall be NEMA 4X rated and made of stainless steel with lockable door.
 - 1. Refer to Section 262416.
- B. Control Panel and Pendant Control Station:
 - 1. Refer to Section 262717.
- C. Grounding
 - 1. Refer to Section 260526.

2. The Embedded parts and gates shall be grounded by being connected to a ground rod as shown in drawing E504. The types of connection and solder used are also shown in drawing E504 and described in Section 260526.

D. Non-automatic Transfer Switches

1. Refer to Section 263613.

E. Electrical Motors (Winches)

1. Refer to Section 262000.

F. Conduits and Junction Boxes

1. Refer to Section 260533.

2.14 EMERGENCY GENERATOR

1. Two (2) portable gasoline generators. Each generator shall have the capacity to supply the electricity required to operate any gates supplied. Portable gasoline generators shall conform to Section 263213.

2.15 SAFETY DOORS

1. The Contractor shall provide one safety door assembly per gate enclosure (gates NG-7 and NG-8) as shown on the Contract Drawings. The safety doors shall be designed to block the access to the enclosures when the gate is closed or stored.
 - a. The safety doors shall be designed to retain the flood debris outside the enclosure during a flood event.
 - b. The safety doors shall allow the natural ventilation through the door.
 - c. The safety doors shall be made of welded carbon steel, shall be composed of a frame, vertical bars and a mesh. The mesh shall prevent the insertion of one-inch diameter ball anywhere on the door surface. The maximum distance between bars shall be 4 inches.
 - d. The door supply shall include latches, hinges, anchors and hardware.
 - e. Each door shall be provided with padlockable latches for the door in the closed position.
 - f. The door shall be vandal proof and heavy duty.
 - g. The door shall be hot dip galvanized.

- h. The door assembly shall resist to a punctual load of 500 pounds applied at any place on any pairs of bars. The maximum deflection of the door frames in any direction is 1/200 of the span.
- i. See the drawings M308 and M309 for the door layouts and other details.

PART 3 - EXECUTION

3.01 ENGINEERING AND DESIGN

- A. All engineering documents shall be signed by a Professional Engineer of the New Jersey State.
- B. The Contractor shall submit for review and evaluation to the Architect/Engineer all project documents including the documents included in Paragraph 1.06 “Submittals”.
- C. The Contractor cannot proceed with the Work included in the Contract Documents without the formal approval of project documents by the Architect/Engineer.
- D. Any equipment design which impacts the Resist Structure shall be strictly coordinated by the Contractor with the gate manufacturer. These include, but are not limited to, the anchoring system, drainage system, embedded parts and underground storage.
- E. Any modifications to the concrete foundation or pilasters resulting from the Contractor’s gate design, will be done at the Contractor’s cost. Any design changes to the concrete structures or other Project components needs to be reviewed and approved by the Architect/Engineer.

3.02 WORKMANSHIP

- A. All metalwork fabrication and machine work shall comply with Section 055000.
- B. All machined surfaces shall meet the minimum tolerances (e.g.: flatness, parallelism, squareness, surface finish) to achieve the required performance.
- C. All Inspections shall comply with Section 014300.
- D. All surface preparation and painting shall be conforming to Sections 099110 - Shop Painting. Refer to the Urban Amenities Plan for the final finishes for the gates.
- E. The manufacturer shall provide access to the State to its shop facilities for inspection of materials, testing, and workmanship. Refer to Section 14300 for requirements.
- F. Machined surfaces inspection shall not be performed using the machine tool which was used to machine the inspected part.

3.03 SHOP TEST

- A. Each gate shall be completely assembled in the shop together with their respective runway and sealing surfaces. Dimensional checks shall be made and recorded and tolerances shall be within values specified in the fabrication drawing. The main rollers shall be aligned within +/- 0.03 inch along a straight line. The tolerances of perpendicularity and parallelism between the different embedded parts shall be demonstrated during the tests.
- B. Each winch shall be tested to confirm gate opening and closing operations.
- C. Each winch shall be jam tested to confirm the overload protection.
- D. A certified test report sealed and signed by a State of New Jersey Professional Engineer shall be provided by the Contractor.
- E. Shop Testing of the gate assembly will be witnessed by DEP or designated representatives. Contractor shall notify Construction Manager three (3) weeks prior to testing any gate assemblies. Notification of the gate tests will include a detailed testing protocol and report formats to be followed.

3.04 INSTALLATION

- A. The Contractor shall prepare for approval the installation drawings and detailed procedures including the required installation tolerances. The installation drawings shall include, but not limited to, the following:
 - 1. A detailed list including all components, parts or equipment to be purchased, with the same specifications that appear on the order forms. This list shall also include each subassembly, identified by its drawing number;
 - 2. Welding symbols;
 - 3. All tolerances and requirements for flatness, parallelism, orthogonality;
 - 4. Non-destructive testing;
 - 5. Bolt tightening instructions;
 - 6. Painting instructions or any other corrosion protection system.
- B. The Gate manufacturer shall provide the services of a Competent technical supervisor site during each gate installation. The technical supervisor shall ensure that the Gate manufacturer requirements will be met during the installation. The Contractor shall provide 24 hours (onsite) for a technical supervisor per rolling gate for installation, testing and commission of the gates. For gates requiring on-site assembly, the manufacturer's

representative is to be on-site at all time during the assembly of the gate. Time does not include travel time for the representative.

- C. The Contractor shall coordinate the supply of the embedded parts and the balance of the gates according to the Contractor approved Construction Schedule.
- D. The installation tolerances of the embedded vertical bearing/sealing bar on each side monolith of the gates shall be coordinated between the Contractor and the Gate manufacturer to ensure optimum functionality and sealing.

3.05 COMMISSIONING

- A. The Commissioning procedure shall be approved by the Architect/Engineer.
- B. The Contractor will be responsible for acquiring a temporary power feed from the utility company and connect to the gate electrical panel.
- C. Gates are to be tested under the following conditions;
 - 1. Gates with permanent winches
 - a. Using Utility power
 - b. Using the portable generator
 - c. Using a vehicle mounted winch comparable to the winch capacity provided in the Contract.
 - 2. Gates without permanent winches
 - a. Using a vehicle mounted winch comparable to the winch capacity provided in the Contract.
- D. After erection and before final acceptance, the rolling gate shall be operated between the latched (stored) position and the latched closed (sealed) position a sufficient number of times to demonstrate to the satisfaction of the Construction Manager that the gate has been properly installed and adjusted as required by the Contract Drawings and Specifications. These tests must be completed using all operation modes. The commission of the gates will include the following:
 - 1. When unlatched, the gate will move freely from one position to the other, with the aid of the supplied winch;
 - 2. When unlatched, the gate will move freely from one position to the other, with the aid of the portable winch;
 - 3. When unlatched, the gate will not move by gravity.

4. The winches and their controls and protections will operate in a satisfying manner;
 5. When latched in either position, the gate will be securely fastened against movement in any direction;
 6. When latched in the closed position, the gate will form a watertight barrier across the gate structures.
- E. Any defects disclosed during tests shall be promptly corrected without additional cost to the State and the tests repeated until the gate has satisfactorily passed the tests. No separate payment will be made for testing and adjusting the gate.

3.06 SPARE PARTS AND SPECIAL TOOLS

- A. The Contractor shall provide one set per gate, any special tools required to operate or maintain the gate.
- B. The Contractor shall supply a manufacturer recommended set of spare parts including seals and lubricants, to accommodate up to five (5) years of maintenance and operation.
- C. The Contractor shall include in his maintenance and operation manual the manufacturer recommended spare parts and current price list.

3.07 CONTRACT CLOSEOUT

- A. Provide in accordance with Section 017700.

Appendix A: Wave Loads Table

RBDH - Protection Wall Wave Loading Corresponding to Rolling Gate Locations - Rev. B										
<i>* All wave loading values come from Coastal Engineering Team document on 2019, November 18th</i>										
10-Year SWL 100-Year Wave Dynamic Wave Force by Goda's Formula		A3N3	A3N4	A3N5A	A3N6	A3N8	A3N9	A3S1	A3S2	A3S7
		Begin ~ End	Begin ~ End	Begin ~ End	Begin ~ End	Begin ~ End	Begin ~ End	Begin ~ End	Begin ~ End	Begin ~ End
		224+10 ~233+25	218+50 ~224+10	215+30 ~218+50	211+25 ~212+25	204+20 ~208+55	200+00 ~204+20	300+00 ~309+75	317+75 ~319+75	325+25 ~351+25
p ₁	Pressure (lbf/ft ²)		103,69	125,62	62,40					71,60
	Elev. (ft, NAVD)		9,3	9,3	9,3					9,4
p ₂	Pressure (lbf/ft ²)		0,00	0,00	0,00					0,00
	Elev.(ft, NAVD)		11,4	11,9	10,7					11,8
p ₃	Pressure (lbf/ft ²)		94,32	111,19	51,32					6,59
	Elev.(ft,NAVD)		7,5	7,0	8,1					4,6
100-Year SWL 100-Year Wave Dynamic Wave Force by Goda's Formula										
p ₁	Pressure (lbf/ft ²)	177,40	327,45	270,88	167,63	51,03	48,68	79,41	79,50	89,01
	Elev.(ft, NAVD)	13,0	13,0	13,0	13,0	13,0	13,1	13,0	13,0	13,2
p ₂	Pressure (lbf/ft ²)	0,00	185,96	152,83	105,24	0,00	0,00	5,79	5,89	21,29
	Elev.(ft, NAVD)	16,1	16,5	16,0	15,0	14,2	14,4	15,5	15,5	15,5
p ₃	Pressure (lbf/ft ₂)	153,60	240,30	192,87	63,80	39,82	32,77	1,24	0,45	0,74
	Elev.(ft,NAVD)	10,3	7,5	7,0	8,1	11,5	12,0	5,4	3,8	4,6
Top-of-wall SWL 100-Year Wave Dynamic Wave Force by Goda's Formula										
p ₁	Pressure (lbf/ft ²)	292,49	279,97	234,20	160,24	40,73	39,91	79,40	79,49	89,00
	Elev.(ft, NAVD)	16,5	17,0	17,0	15,0	15,0	15,5	15,0	15,0	15,5
p ₃	Pressure (lbf/ft ²)	205,63	158,10	127,51	36,23	21,41	8,07	0,35	0,13	0,17
	Elev.(ft, NAVD)	10,3	7,5	7,0	8,1	11,5	12,0	5,4	3,8	4,6
Corresponding Rolling Gates (Stationing's of gate center)		NG-11 233+16	NG-9 223+51	NG-8 216+86	NG-7 211+42	NG-5 206+28	NG-2 202+96	SG-3 308+33	SG-4 318+93	SG-5 327+08
Note: waves loads are given as hydrodynamic pressures and does not include hydrostatic pressures.										
See the image below for p ₁ ,p ₂ ,p ₃ locations										

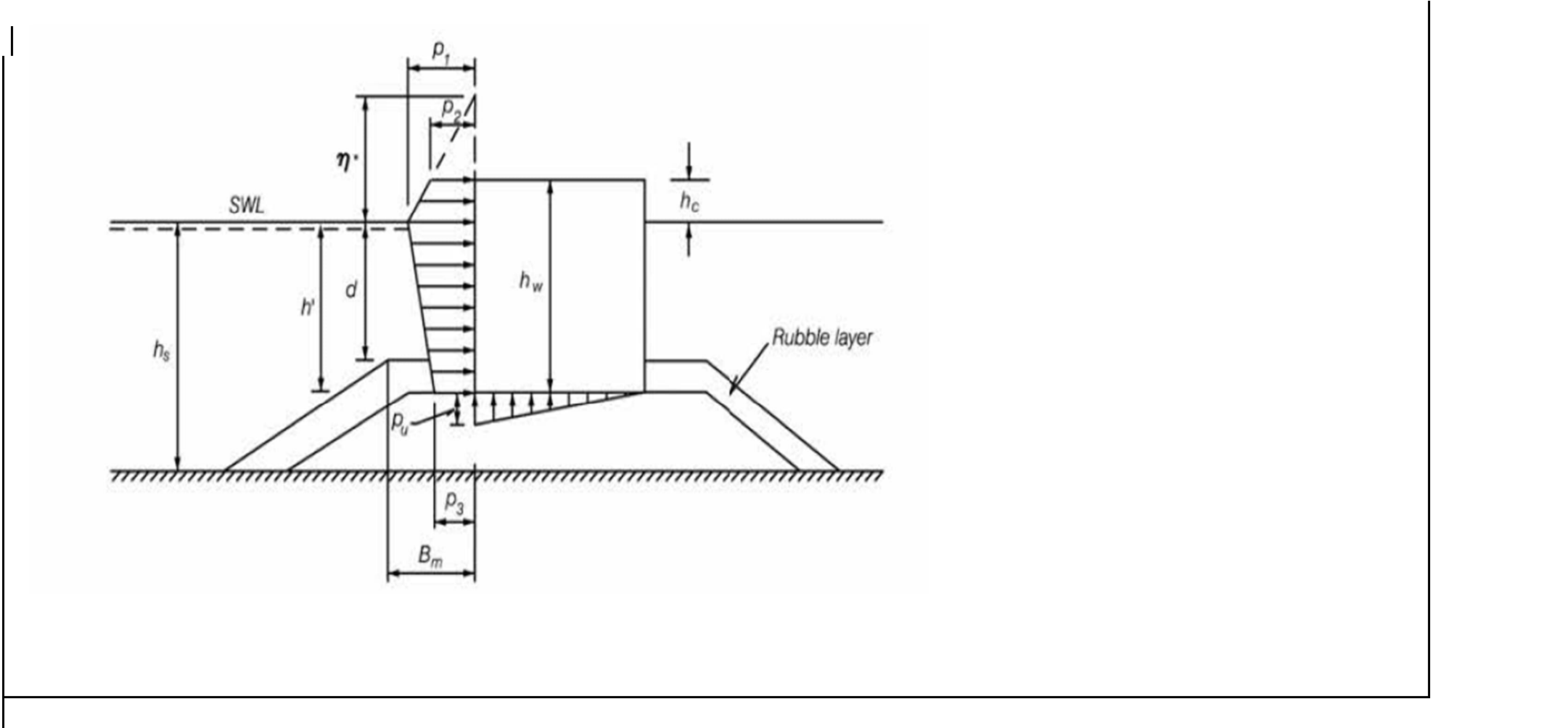

RBDH - Protection Wall Wave Loading Corresponding to Rolling Gate Locations - Rev. A										
<i>* All wave loading values come from Coastal Engineering Team document on 2019, November 18th</i>										
10-Year SWL 100-Year Wave Dynamic Wave Force by Goda's Formula		A3S7	A3S7	A3S7	A3S7	A3S9	A3S10	A3S10	A3S11	A3S11
		Begin ~ End	Begin ~ End	Begin ~ End	Begin ~ End	Begin ~ End	Begin ~ End	Begin ~ End	Begin ~ End	Begin ~ End
		325+25 ~351+25	325+25 ~351+25	325+25 ~351+25	325+25 ~351+25	352+00 ~355+71	409+68 ~411+40	409+68 ~411+40	400+30 ~405+00	400+30 ~405+00
p1	Pressure (lbf/ft ²)	54,37	89,48	89,12	89,66				32,49	
	Elev.(ft, NAVD)	9,4	9,4	9,4	9,4				9,5	
p2	Pressure (lbf/ft ²)	0,00	0,00	0,00	0,00				0,00	
	Elev.(ft, NAVD)	10,9	12,4	12,4	12,4				10,4	
p3	Pressure (lbf/ft ²)	32,30	14,29	7,71	16,13				18,48	
	Elev.(ft,NAVD)	8,0	5,5	4,5	5,7				8,0	
100-Year SWL 100-Year Wave Dynamic Wave Force by Goda's Formula		TBD								
p1	Pressure (lbf/ft ²)	89,09	89,02	89,01	89,02	39,50	39,64		27,64	27,89
	Elev.(ft, NAVD)	13,2	13,2	13,2	13,2	13,2	13,4		13,3	13,3
p2	Pressure (lbf/ft ²)	21,31	21,29	21,29	21,29	0,00	0,00		0,00	0,00
	Elev.(ft, NAVD)	15,5	15,5	15,5	15,5	14,5	14,7		14,2	14,2
p3	Pressure (lbf/ft ₂)	6,39	1,31	0,69	1,48	9,49	0,21		1,86	5,98
	Elev.(ft,NAVD)	8,0	5,5	4,5	5,7	10,0	4,1		8,0	9,9
Top-of-wall SWL 100-Year Wave Dynamic Wave Force by Goda's Formula		TBD								
p1	Pressure (lbf/ft ²)	89,02	89,01	89,00	89,01	38,98	39,64		27,64	27,64
	Elev.(ft, NAVD)	15,5	15,5	15,5	15,5	15,5	15,5		15,5	15,5
p3	Pressure (lbf/ft ²)	1,48	0,30	0,16	0,34	2,31	0,05		0,46	1,54
	Elev.(ft, NAVD)	8,0	5,5	4,5	5,7	10,0	4,1		8,0	9,9
Corresponding Rolling Gates (Stationing's of gate center)		SG-6 332+51	SG-7 338+44	SG-8 341+68	SG-9 343+68	SG-12 351+09	SSG-3 409+81	SSG-4 410+85	SSG-1 401+00	SSG-2 403+93

END OF SECTION 353130

SECTION 353131 – SWING GATES AND APPURTENANCES

PART 1 - GENERAL

1.01 SUMMARY

- A. The Contract Documents provide a preliminary design of the flood gates. The Contractor will be required to provide detailed design and calculations to the Architect/Engineer for review and approval prior to fabrication.
- B. Work included:
 - 1. Preparing and submitting detailed shop drawings including detailed calculations and final design of the gates for the Architect/Engineer's review as required in General Conditions Article 4.7.
 - 2. Provide and install all swing gates and appurtenances included in the Contract Drawings, including the hinges, anchors, seals, bearing bars, latches, guides, supports, central posts, the embedded sealing surfaces, all operation modes accessories and other auxiliary parts needed for a complete installation;
 - 3. Packaging and transportation of the gates and appurtenances to the project site including all handling, permits and temporary storage of the gates;
 - 4. All labor and equipment needed for the installation of the gates and appurtenances;
 - 5. Preparing and submitting the operation and maintenance manual as required in Section 017823 and General Conditions Article 8.2;
 - 6. Shop testing of the gates prior to delivery to the site;
 - 7. Site testing and commissioning;
 - 8. Services of the gate manufacturer's representative to assist the Contractor in the installation, testing and commissioning of the gates.
 - 9. Providing the O&M training to be conducted by the gate manufacturer's representative and including classroom and field training. Training is to be recorded in accordance with General Conditions Article 8.3. Training materials, handouts and agenda to be submitted to the Architect/Engineer for review and approval at least one month prior to any training.

1.02 PAYMENT

- A. All costs for Work required by this Section shall be included in the applicable lump sum(s), as set forth in Section 012901.

1.03 RELATED SECTIONS

- A. General Conditions Article 4.7 – Shop Drawings and Other Submittals.
- B. General Conditions Article 8.2 – Operations, Equipment and Maintenance Manuals.
- C. General Conditions Article 8.3 – Training.
- D. Section 012901 – Measurement and Payment.
- E. Section 014300 - Quality Requirements.
- F. Section 016100 - Control of Materials.
- G. Section 017700 – Contract Closeout.
- H. Section 017823 - Operation and Maintenance Manual.
- I. Section 031000 – Concrete Formwork.
- J. Section 033000 – Cast-in-Place Concrete.
- K. Section 051200 - Structural Steel.
- L. Section 055000 - Miscellaneous Metal.
- M. Section 099110 - Shop Painting.
- N. Section 260526 – Grounding and Bonding for Electrical Systems.

1.04 DEFINITIONS

- A. Exterior side: The exterior side of the gates or Resist Structure is the unprotected or flood side.
- B. Gate Slab: The gate slab is located under the gate and expands on each side of the gate. The gate sill embedded parts are integrated into this slab. The gate slab transfer loads from the gate to the ground, such as dead load and hydrostatic load transferred from the central posts of the longer gates. This slab is provided by the Contractor.
- C. Interior Side: The interior side of the gates or Resist Structure is the protected side against flood.

- D. Monolith: The Resist Structure vertical pilasters.
- E. Seal Preset: The extent the seal stem should be placed under deflection. The preset cause initial seal compression on the seal plate without water pressure.
- F. Hold Point: During the manufacturing in the workshops, the Construction Manager is invited for a hold point with a minimal two (2) weeks' notice. During the field work on site, the Construction Manager is invited for a hold point with a minimal two (2) weeks' notice. The Contractor's Project activity affected by the hold point shall be stopped until the acceptance of the Construction Manager.
- G. Check Point: During the manufacturing in the workshops, the Construction Manager is invited for a check point with a minimal two (2) weeks' notice. During the field work on site, the Construction Manager is invited for a check point with a minimal two (2) weeks' notice. The Construction Manager may decide to attend or not to a check point. A check point does not stop any of the Contractor's Project activities.

1.05 CODES, STANDARDS AND OTHER PUBLICATIONS

- A. All gates shall be structural parts of the Resist Structure during operation and design according to sound engineering practice, as per USACE & FEMA 44 CFR 65.10(b)(2).
- B. For any discrepancy related to the swing gate design, the documents would supersede on another in the following order: the Codes, this Section, the Contract Drawings, the USACE publications, and the other standards and publications.
- C. If no year is indicated, the most up to date version of codes, standards, and other publications shall be used.
- D. The publications listed below form a part of this Section.
 - 1. AISC – Codes, Specifications, Design Manuals and Steel Construction Manual;
 - 2. ASME Structural Welding Code Section IX;
 - 3. AWS-D1, D1.2, D1.3 & D1.6 – Structural Welding Code;
 - 4. USACE ETL 1110-2-584 – Design of Hydraulic Steel Structures;
 - 5. USACE EM 1110-2-2104 – Strength Design for Reinforced Concrete Hydraulic Structures;
 - 6. OSHA Regulations and standards.
- E. The publications listed below form a part of this Section to the extent referenced. The publications are referred to within the text by the basic designation only.

1. ASCE 7-10 – Minimum Design Loads for Buildings and Other Structures.
2. International Code Council (ICC), International Building Code, New-Jersey Edition;
3. ASTM INTERNATIONAL (ASTM)
 - a. ASTM D 395 Standard Test Methods for Rubber Property - Compression Set.
 - b. ASTM D 412 Standard Test Methods for Vulcanized Rubber and Thermoplastic Elastomers – Tension.
 - c. ASTM D 471 Standard Test Method for Rubber Property - Effect of Liquids.
 - d. ASTM D 572 Rubber Deterioration by Heat and Oxygen.
 - e. ASTM D 2240 Standard Test Method for Rubber Property - Durometer Hardness.

1.06 SUBMITTALS

A. Project Submittals

1. Submit the following items in accordance with General Conditions Article 4.7 Documents signed and sealed by a New Jersey Professional Engineer will only be reviewed evaluated for design approach and completeness.
 - a. The Contractor shall prepare and submit for the review and evaluation of the Architect/Engineer: document register / plan, quality control and assurance plans, detailed schedule, general arrangement drawings, detailed calculations, technical data sheets, shop test procedures, installation procedures and commissioning test procedures. Drawings and calculations are to be signed and sealed by a New Jersey Professional Engineer.
 - b. The Contractor shall prepare and submit for the review and evaluation of the Architect/Engineer: complete shop and assembly drawings and descriptive literature showing details of the swing gate required as indicated herein and on the Contract Drawings. Shop drawings shall indicate computed weights of structural steel and approval of shop drawings will constitute acceptance of the computed weights shown on these drawings. Drawings and calculations are to be signed and sealed by a New Jersey Professional Engineer. Drawings shall also include, but not limited to:
 - (1) a detailed list including all components, parts or equipment to be purchased, with the same specifications that appear on the order forms of the gates and appurtenances;

- (2) the specification of materials;
 - (3) welding symbols;
 - (4) machining instructions;
 - (5) all tolerances and requirements for flatness, parallelism, orthogonality, hardness and surface finish;
 - (6) heat treatments;
 - (7) non-destructive testing;
 - (8) bolt tightening instructions;
 - (9) painting instructions or any other corrosion protection system.
- c. Contractor shall allow a minimum of 3 weeks for approval of shop drawings, calculations and other submittals.
 - d. Field Assembly – if any of the gates are to be assembled at the project site following delivery, the Contractor shall submit detailed work methods including the following:
 - (1) Area needed for assembly;
 - (2) Equipment and tools needed to assemble the gate sections;
 - (3) Information on parts needed to assure watertight assembly;
 - (4) Approximate time needed to assemble the gate sections into a complete gate.
2. Operations and Maintenance Manual Submittals
 - a. Refer to General Conditions Article 8.2
 - b. Detailed operation and maintenance manual that shall include, but not limited to, the following technical elements:
 - (1) table of contents;
 - (2) complete drawings list;
 - (3) table summarizing the technical specifications of the components;

- (4) a detailed description of the operation procedures of the equipment including deployment time;
- (5) a list of preventive maintenance and inspections including the frequency of these inspections;
- (6) troubleshooting section;
- (7) lubrication instructions, with a table summarizing the points to be lubricated, the type of lubricants and the lubrication frequency;
- (8) the list of spare parts;
- (9) detailed description of all components with assembly, adjustment and maintenance instructions;
- (10) copy of the purchase orders for all the components;
- (11) scaled 11x17 copy of all the drawings of assemblies and subassemblies.

1.07 QUALITY CONTROL

- A. Comply with the requirements of Section 014300.
- B. General: The Contractor is fully responsible for ensuring compliance with all tolerances required to achieve the performances included in Contract Documents. The Contractor shall also establish and maintain quality control for swing gate operations to ensure compliance with Contract Documents and maintain records of his quality control for all construction operations including, but not limited to, the following:
 1. Ensure timely submittal of shop drawings.
 2. Inspection on delivery of fabricated items for damage, defects, and conformance with approved shop drawings.
 3. Installation in conformance with manufacture's recommendation and contract requirements.
- C. Reporting: The original and two copies of these records and tests, as well as corrective action taken, shall be furnished to the Construction Manager daily. Format of the report shall be agreed with the Construction Manager before submission.
- D. Quality Plan: The Contractor shall submit for approval his detailed quality plan (as per Section 014300). The quality plan shall include descriptions of inspections and tests to be performed during the manufacturing, installation and commissioning.

The quality plan shall include the proposed Project hold points and check points involving the Construction Manager during the manufacturing, installation and commissioning. These Hold and Check Points shall include, as a minimum and not limited to, the following:

1. Manufacturing:
 - a. Acceptation of material mill tests certificates Check Point
 - b. Tack welded pre-assembly dimensions inspection Check Point
 - c. Final assembly dimensions and tolerances inspection Hold Point
 - d. Acceptation of stress relief report before machining Check point
 - e. Machining tolerances inspection Hold Point
 - f. Surface preparation before coating inspection Hold Point
 - g. Coating application inspection (including environmental parameters and film thickness in case of paint coating) Hold point
 - h. Pre-shipping inspection and review of the manufacturing quality records, including, as a minimum and not limited to:
 - (1) Quantities;
 - (2) Possible damages due to handling;
 - (3) Latching and Protection.Hold Point
2. Installation:
 - a. Site receiving and storage, as a minimum and not limited to:
 - (1) Quantities;
 - (2) Possible damages due to transportation and unloading;
 - (3) Storage protection.Check Point

- | | |
|--|------------|
| b. Adjustment dimensions and alignment tolerances inspection of embedded parts before concreting | Hold Point |
| c. Alignment tolerances inspection of embedded parts after concreting | Hold Point |
| d. Paint and galvanization touch up and cleanliness inspection | Hold point |
| e. Commissioning tests | Hold Point |
| f. Final acceptance inspection including review of the quality records | Hold Point |

E. Tests and Inspections:

1. Weld Testing: In addition to visual inspection, all welds shall be tested and inspected, at a minimum, according to AWS D1.1/D1.1M and the inspection procedures listed in subparagraphs below.

<u>Weld Type</u>	<u>Inspection Type</u>	<u>Proportion to be inspected</u>
Full penetration butt weld in flanges and parts in tension	Radiographic	50%
	or Ultrasonic	100%
Butt weld in flanges and parts in Compression	Radiographic	5%
	or Ultrasonic	50%
Full penetration butt weld in flanges and parts with alternating stress or dynamically stressed	Radiographic	100%
Full web penetration butt weld	Magnetoscopic or Dye Penetrant	10%
Fillet welds and partial penetration welds	Magnetoscopic or Dye Penetrant	10%

2. The Engineer reserves the right to modify the location of the inspections indicated in the above table without however exceeding the total percentage indicated for each type of weld.

3. The Contractor must indicate on his detail drawings, which must be submitted for verification by the Engineer, all the critical welds that are subject to the various inspection methods mentioned above, so as to verify whether they meet the requirements of the technical specifications.
4. Unacceptable defects shall be gouged to sound metal and exposed parts after gouging shall be subjected to non-destructive examination satisfactory to the Engineer. All repair welds must be 100% inspected by the inspection method originally used.
5. When an inspected area reveals defects subject to repair, adjacent areas should also be inspected using the same method. If any of the adjacent areas also show unacceptable defects, the weld should be inspected in its entirety.
6. All non-destructive testing on welds shall be done in accordance with:
 - a. Dye Penetrant Inspection: ASTM E 165.
 - b. Magnetoscopic Inspection: ASTM E 709.
 - c. Radiographic Inspection: ASTM E 94.
 - d. Ultrasonic Inspection: ASTM E 164.

F. Supplemental Special Inspections and Testing:

1. The DEP may engage qualified special inspectors to perform oversight of the gate manufacturing, assembly, testing and inspections performed by the Contractor and its inspection and testing agency. The Contractor to provide testing agency access to the work as required.

1.08 WARRANTY

- A. Swing gates shall operate in accordance with Contract Documents and be free of defects in material and workmanship for a period of not less than three (3) years from the date of final acceptance.

1.09 DELIVERY, STORAGE, AND HANDLING

- A. Conform with the requirements of Section 016100.
- B. Deliver equipment with protective crating and covering.
- C. Store equipment to prevent damage and protect from weather, dirt, fumes, water, snow, ice and construction debris until final delivery date to the construction site.
- D. All stored or unsecured parts shall be locked to ensure security and operability.

PART 2 - PRODUCTS

2.01 GATE DESIGN DESCRIPTION

A. Swing gates

1. General: Swing gates are supported by two (2) hinges on one (1) side and are stabilized in open and closed position by an adjustable support device. Double leaf swing gates consist of two (2) single gates that close on a central removable post.
2. Structures: The gate structure is composed of horizontal girders, vertical intercostals, diaphragms, bracings, and skin plate.
3. Central posts: As indicated on the Contract Drawings, in the closed position and in preparation for a flood event, each double leaf gates will be supported by one central post in order to limit the gate deflection and also to reduce the loads transferred to the Resist Structure Monoliths during a flood. These posts shall be stored underground, as shown on the Contract Drawings, when the gate is in the stored position. The underground storage location of the central posts shall include a drain as shown on Contract Drawings. This storage location shall be closed by a structural cover rated at AASHTO H-20 loads and be lockable with a recessed locking mechanism.
4. Hinges: Gate hinges and pins shall resist to all loads including hydrostatic, gravity and operational loads (by hand or with machinery and towing points).
5. Support device: The gate shall include a support device to reduce the load on hinges when the gate is not moving. During closure, the gate shall be stable when closed with a maximum wind of 40 mph (peak) acting on the gate in any direction.
6. Bearing bars: The hydrostatic loads shall be transferred from the gate structure to the Resist Structure Monoliths by bearing bars. The bearing bar shall be configured to allow water pressure to increase the compression of the seal.
7. Seals: All gate seals shall be “J” type, or music note seals. To minimize friction, the seals shall not be in contact with the sealing surfaces when the gate is stored or during the rotation. When the gates are in the closed position, their seals shall be preset enough to ensure proper sealing for any flood level below the top of the gate.
8. Seals clamp bars: Seals shall be bolted on the gate with clamp bars as per the seal manufacturer’s recommendations.
9. Latching devices: The gates shall be provided with latching devices for securing the gates in the closed and stored position. The latching device shall be heavy-duty and lockable.

10. Nameplates: Gates shall be provided with nameplates. Nameplates shall be approved by the Architect/Engineer.
11. All components of the gates required to operate the gates shall be stored and locked in the gate, when possible, otherwise in a cabinet in the gate storage area. All removable equipment and parts are to be stored with the gate. Storage cabinets are to be sized and compartmentalized to fit all the loose components.
12. The gate structure shall be provided with reflective warning signs as shown on the Urban Amenities Plans.

B. Embedded parts

1. General: The embedded parts are the static structures embedded into the Resist Structure Monoliths and into the gate slab. The embedded parts consist of the assembly of the hinges, bearing bars, sealing surfaces and central post brackets with their respective supports and anchors.
2. Bearing bars: The bearing bars of the gate transfer the loads to the bearing bars of the Resist Structure Monoliths.
3. Side sealing surfaces: Leveled, adjusted, and continuous surface that will ensure proper sealing with the gate side seals.
4. Sill sealing surfaces: Leveled, adjusted, and continuous surface that will ensure proper sealing with the gate sill seals.
5. Central post brackets: The central posts transfer their loads to the brackets located on the interior side of the Gates. These brackets are anchored in the gate slab.
6. Anchors: Anchors shall be injectable adhesive type (post-installed in the concrete) and /or cast-in-place anchors and shall be approved by the Architect/Engineer. The Contractor is responsible for the anchors that shall be installed, and their design needs to rely on the concrete and rebar to resist pull out and prevent any other type of failure; the anchor design should not require adding rebar to the concrete structure design.
7. Interferences with rebar: The gate manufacturer shall coordinate his design with the Contract Drawings and with the Contractor to avoid drilling in rebar during anchors installation.
8. Concrete pouring: The gate slab consists in the first phase of concrete pouring. After their installation and alignment, the embedded parts, supports and anchors will be buried into the second concrete phase.

C. Equipment assisted operation

1. All swing gate leaf shall be provided with tie-points in order to be opened and closed with the assistance of trucks, loaders or similar equipment. The tie points shall be compatible with wire rope or hooks. Additionally, a steel contact plate is to be installed so that the gate can be pushed closed or open without damaging the other component of the gate.

D. Limit switches on Gate NG 10:

1. Two (2) proximity switches shall be provided on each pilaster of the gate to detect that the leaf of the gate is fully open. A junction box shall be installed on each pillar to allow signal cables of proximity switches from both sides of the gate to pass through. The junction box on each side of the gate shall provide access to the signal cables of all four proximity switches. Hudson Bergen Light Rail (HBLR) shall route the cables from the junction box to the HBLR signal system panelboard.

2.02 OTHER REQUIREMENTS

A. Operating conditions

1. The gate, frame and appurtenances shall be designed in a way to avoid being damaged by vehicular traffic, machinery and snow removal machinery.
2. The bottom seal of the swing gates shall have a minimum ground clearance during opening and closing movements to avoid any damage on the bottom seal.
3. The supply shall be designed and shall be provided with the required adjustments to allow proper gate closure, alignment, latching and sealing.

B. Sealing performance

1. The gate seals leakage flow shall not exceed 0.2 gallon per minute per linear foot of seal.

C. Removable parts

1. All removable parts shall be assembled with stainless steel axel or pin with retaining chains or anti-theft device and be stored into their assembly location.

D. Grounding

1. Refer to Section 260526 – Grounding and Bonding for Electrical Systems.
2. The Embedded parts and gates shall be grounded by being connected to a ground rod as shown in drawing E504. The types of connection and solder used are also shown in drawing E504 and described in Section 260526 - Grounding and Bounding for Electrical Systems.

2.03 ALLOWABLE STRESSES AND LOADS

- A. Swing gates and embedded parts: as per USACE ETL 1110-2-584. This design can be done with the limit state (LRFD) method or with the allowable stress design (ASD) method.
- B. Concrete and anchors: as per USACE EM 1110-2-2104.
- C. Maximum allowable stress on the concrete: 1700 PSI.

2.04 ALLOWABLE DEFLECTIONS

- A. The maximum gate girder deflection is 1/600 of the beam span. Allowable deflection may be smaller than this value because of the sealing or other detailed design criteria.
- B. The central posts structural cover shall have a maximum deflection of 1/400 of the cover span with maximum vehicle load.

2.05 MINIMUM MATERIAL THICKNESS

- A. The minimum thickness of the gate structural components is 0.25 inch.
- B. The minimum thickness of the sealing surfaces plates is 0.375 inch after machining.
- C. The minimum thickness of the embedded parts is 0.25 inch.

2.06 AMBIENT CONDITIONS

- A. The gate shall be operated normally between 20 degrees F and 110 degrees F.
- B. The gates shall be fully operative below freezing point after seals and hinges deicing.
- C. The gate will be stored outside at a temperature between -10 degrees F and 120 degrees F.
- D. The humidity index can vary between 0 percent and 100 percent.
- E. The gate, frame and appurtenances shall not be damaged by ambient conditions, brackish water during flooding or storage.
- F. Overtopping water caused by waves shall not cause gate operational issues such as excessive vibration and seal leakage.

2.07 LOAD CASES AND LOAD COMBINATION

- A. Loads

1. All Gate loads: as per USACE ETL 1110-2-584.
2. Impact loading: 500 pounds per linear foot on the full length of the upper gate girder.
3. Wind loading: as per ASCE 7-10
4. Wave loading: see the Appendix A (at the end of this section).
5. Seismic loading: Shall be evaluated as per ICC), International Building Code, New-Jersey Edition and ASCE 7-10.
6. The gate system and its latching device shall be designed for wind up to 135 MPH with minimum safety factor of 2 on the yield strength of the materials. In this case, the gate is closed and there is no flood.

B. Load combination

1. The loads shall be combined in the worst possible ways to ensure that the gates will perform as expected.
2. Swing gates and embedded parts: as per USACE ETL 1110-2-584.
3. Concrete and anchors: as per USACE EM 1110-2-2104.

2.08 MATERIAL GRADES, TYPES, AND CLASSES

A. General:

1. Metals and steels supplied shall be new and of the highest quality and shall conform to the minimum requirements of the material specifications specified. . Specifications, mill certificates and Non-Destructive Examination (NDE) records shall be obtained for all metals and issued to the Construction Manager for the permanent record. These documents shall include, but are not limited to, heat numbers, unique item identification, chemical compositions/analysis and mechanical properties (yield and tensile strengths, elongation and Charpy V-notch impact test results).
2. Requests to use alternative equipment or materials shall be submitted per General Conditions Article 4.7.5.
3. Dissimilar Materials: The assembly design and installation shall ensure that:
 - a. Aluminum shall be physically separated from concrete.
 - b. Dissimilar metals shall be physically separated.

4. Before starting fabrication, Contractor shall submit to Construction Manager the certificates of the tests executed in steel mill corresponding to the materials to be used. Refer to Section 051200 for details.
 5. Castings
 - a. Castings shall adhere to the following standards:
 - b. Carbon steel castings – ASTM A-27, Grade 70-40;
 - c. Stainless steel castings – ASTM A-743, Grade CA-6NM.
 6. Forgings
 - a. Forgings shall adhere to the following standards:
 - b. Carbon steel forgings – ASTM A-470 Class 4;
 - c. Stainless steel forgings – ASTM A-182.
- B. Materials for the gate shall be as follows:
1. Gate structure: as per Section 051200.
 2. Hinge pins: SAE Type 630 Hardened Stainless Steel.
 3. Hinge bearings: Self-lubricating bearing, plain bearing type. Plastic creep shall be avoided. Bearings shall have a minimum of 10 years of successful history in similar applications. References of similar applications shall be provided.
 4. Stabilizing system: as per Section 051200.
 5. Bearing bars: as per Section 051200.
 6. Seals clamp bars: ASTM A276 Type 304 Stainless steel.
 7. Latching devices: as per Section 051200.
 8. Structural Fasteners (Bolts, nuts and washers): ASTM A325 Hot-Dip Galvanized.
 9. Seals Fasteners: AISI 304, ASTM A193 Gr B8.
- C. Materials for the embedded parts shall be as follows:
1. Embedded parts: as per Section 051200.
 2. Sealing Plates: ASTM A276 Type 304 Stainless steel.

3. Embedded Anchors: ASTM A325.
4. Semi-embedded Anchors: ASTM A276 Type 304 Stainless steel.

D. Other materials:

1. Central post storage covers: ASTM A276 Type 304 Stainless steel.
2. Central post storage frame and semi-embedded steel: ASTM A276 Type 304 Stainless steel.
3. Central posts and brackets: Hot Dip Galvanized steel, as per Section 051200.
4. Central posts pins: ASTM A276 Type 304 Stainless steel.

E. Gate seals

1. Gate seals shall be molded, and the material shall be compounded of natural rubber. Seal material shall contain reinforcing carbon black, zinc oxide, accelerators, antioxidants, vulcanizing agents, and plasticizers.
2. Gate seals shall be “J” type and shall be conforming with ASTM standards including the following requirements: minimum Tensile Strength of 2.5 KSI, minimum Ultimate Elongation of 450 percent, 0.9 KSI for an Elongation of 300 percent, maximum 10 percent water absorption, minimum 80 percent of tensile strength after aging and maximum 30 percent of permanent compressive deformation.
3. All joints in seals shall be spliced by vulcanization. All holes in the gate seals shall be drilled as per manufacturer's recommendations.
4. Gate Seals shall not contain reclaimed polymers nor internal reinforcement with metal and/or canvas, natural or synthetic fiber.
5. Seals hardness shall be selected as required for the application.
6. Seals materials shall be tested as per applicable ASTM standards.

2.09 OPERATING CONDITION REQUIREMENTS

A. Gate operation.

1. Maximum deployment duration per gate opening (for a five (5) trained workers crew):
 - a. Single leaf: 45 minutes

- b. Double leaf: 90 minutes
 - 2. The gate shall close easily during the design life.
 - 3. The gate design shall minimize the risks (binding or wheel freezing) of delaying or stopping the gate deployment.
 - 4. The gate shall be latched and locked in the closed position.
 - 5. The gate operations shall comply with OSHA 29CFR1910 requirements.
- B. Gate storage
- 1. The gate storage locations are shown on the Contract Drawings.
 - 2. The gate shall be latched and locked in the stored position.
 - 3. The gate storage footprint shall be minimized.
- C. Flood Event
- 1. No gate components shall have to be replaced because of the flooding on the exterior side of gates.
- D. Gate operation modes
- 1. Primary: Manual mode. Swing gate can be operated manually pushing the gate closed or open by hand by a three (3) persons crew when the wind is under 10 mph (peak).
 - 2. Secondary: Vehicles or other machinery using the towing points can be used as a backup means of deployment or if the wind speed is 10 MP to 40 MPH (peak). Sheaves and towing points shall be provided so that the gate can be pulled closed or a contact plate if the gate is pushed closed.
- 2.10 MAINTENANCE REQUIREMENT
- A. All components shall be easily accessible for visual inspection and maintenance and shall be conforming to Section 017823.
 - B. All components that may be replaced due to normal wear and tear, shall be easily accessible for inspection and repair or replacement.
 - C. The maintenance requirements are applicable when the gates are in the closed and stored position.

- D. Gate seals shall be easily replaceable when the gates are on the stored position. Seals replacement shall not require heavy equipment to maneuver the gate.
- E. All padlocks provided for the gates shall be keyed identically, Contractor to provide a minimum of four (4) sets of keys for each gate padlock.

2.11 DESIGN LIFE

- A. The gate design life shall be at least for 50 years of operation. This design life takes into consideration normal annual maintenance. The gate shall not require major rehabilitation during this design life period.

2.12 HEALTH, SAFETY AND ENVIRONMENT REQUIREMENTS

- A. Gate components shall not to contain any hazardous materials.
- B. The gates shall not cause environmental damages due to spillages such as lubricant leaks.
- C. The gates shall conform to the applicable OSHA 29CFR1910 regulations.

PART 3 - EXECUTION

3.01 ENGINEERING AND DESIGN

- A. All engineering documents shall be signed by a Professional Engineer of the New Jersey State.
- B. The Contractor shall submit for review and evaluation to the Architect/Engineer all project documents including the documents included in Paragraph 1.06 “Submittals”.
- C. The Contractor cannot proceed with the Work included in a Contract Documents without the formal approval of project documents by the Architect/Engineer.
- D. All equipment design elements which impact the Resist Structure shall be strictly coordinated by the Contractor with the gate manufacturer. These include, but are not limited to, the anchoring system, drainage system, embedded parts and underground storage.
- E. All modifications to the concrete foundation or pilasters resulting from the Contractor’s gate design, will be done at the Contractor’s cost. Any design changes to the concrete structures or other Project components need to be reviewed and approved by the Architect/Engineer.

3.02 WORKMANSHIP

- A. All metalwork fabrication and machine work shall comply with Section 055000 - Miscellaneous Metal.
- B. All machined surfaces shall meet the minimum tolerances (e.g.: flatness, parallelism, squareness, surface finish) to achieve the required performance.
- C. All Inspections shall comply with Section 014300.
- D. All surface preparation and painting shall be conforming to Sections 099110 Refer to the Urban Amenities Plan for the final finishes for the gates.
- E. The manufacturer shall provide access to the State to its shop facilities for inspection of materials, testing, and workmanship. Refer to Section 14300.
- F. Machined surfaces inspection shall not be performed using the machine tool which was used to machine the inspected part.

3.03 SHOP TEST

- A. Each gate shall be completely assembled in the shop together with their respective hinges and sealing surfaces. Dimensional checks shall be made and recorded and tolerances shall be within values specified in the fabrication drawing.
- B. A certified test report sealed and signed by a State of New Jersey Professional Engineer shall be provided by the Contractor.
- C. Shop Testing of the gate assembly will be witnessed by DEP or designated representatives. Contractor shall notify Construction Manager three (3) weeks prior to testing any gate assemblies. Notification of the gate tests will include a detailed testing protocol and report formats to be followed.

3.04 INSTALLATION

- A. The Contractor shall prepare for approval the installation drawings and detailed procedures including the required installation tolerances. The installation drawings shall include, but not limited to, the following:
 - 1. A detailed list including all components, parts or equipment to be purchased, with the same specifications that appear on the order. This list shall also include each subassembly, identified by its drawing number;
 - 2. welding symbols;
 - 3. all tolerances and requirements for flatness, parallelism, orthogonality;

4. non-destructive testing;
 5. bolt tightening instructions;
 6. painting instructions or any other corrosion protection system.
- B. The Gate Manufacturer shall provide the services of a competent technical supervisor during each gate installation. The technical supervisor shall ensure that the Gate Manufacturer requirements will be met during the installation. Contractor shall provide 24 hours (onsite) for a technical supervisor per swing gate for installation, testing and commission of the gates. For gates requiring on-site assembly, the manufacturer's representative is to be on-site at all times during the assembly of the gate. Time does not include travel time for the representative.
- C. The Contractor shall coordinate the supply of the embedded parts and the balance of the gates according to the Contractor approved Construction Schedule.
- D. The installation tolerances of the embedded vertical bearing/sealing bar on each side monolith of the gates shall be coordinated between the Contractor and the Gate Manufacturer to ensure optimum functionality and sealing.

3.05 COMMISSIONING

- A. The Commissioning procedure shall be approved by the Architect/Engineer.
- B. After erection and before final acceptance, the swing gate shall be operated between the latched (stored) position and the latched closed (sealed) position a sufficient number of times to demonstrate to the satisfaction of the Construction Manager that the gate has been properly installed and adjusted as required by the Contract Drawings and Specifications. These tests must be completed using all operation modes. The commission of the gates will include the following:
1. when unlatched, the gate will move freely by hand from one position to the another;
 2. when unlatched, the gate won't move by gravity;
 3. when latched in either position, the gate will be securely fastened against movement in any direction;
 4. when latched in the closed position, the gate will form a watertight barrier across the gate structures.
- C. Any defects disclosed during tests shall be promptly corrected without additional cost to the State and the tests repeated until the gate has satisfactorily passed the tests. No separate payment will be made for testing and adjusting the gate.

3.06 SPARE PARTS AND SPECIAL TOOLS

- A. The Contractor shall provide one set per gate, any special tools required to operate or maintain the supply.
- B. The Contractor shall supply a manufacturer recommended set of spare parts, including seals and lubricants to accommodate up to five (5) years of maintenance and operation.
- C. The Contractor shall include in his maintenance and operation manual a recommended spare parts and pricing list.

3.07 CONTRACT CLOSEOUT

- A. Provide in accordance with Section 017700.

Appendix A: Wave Loads Table

RBDH - Protection Wall Wave Loading Corresponding to Swing Gate Locations - Rev.B								
<i>* All wave loading values come from Coastal Engineering Team document on 2019, November 18th</i>								
10-Year SWL 100-Year Wave Dynamic Wave Force by Goda's Formula		A3N3	A3N7	A3S1	A3S1	A3S7	A3S7	A3S9
		Begin ~ End	Begin ~ End	Begin ~ End	Begin ~ End	Begin ~ End	Begin ~ End	Begin ~ End
		224+10 ~233+25	208+55 ~211+25	300+00 ~309+75	300+00 ~309+75	325+25 ~351+25	325+25 ~351+25	352+00 ~355+71
p ₁	Pressure (lbf/ft ²)	176,32					59,81	
	Elev.(ft, NAVD)	9,3					9,4	
p ₂	Pressure (lbf/ft ²)	0,00					0,00	
	Elev.(ft, NAVD)	13,2					11,1	
p ₃	Pressure (lbf/ft ²)	146,64					32,56	
	Elev.(ft,NAVD)	5,9					7,8	
100-Year SWL 100-Year Wave Dynamic Wave Force by Goda's Formula								
p ₁	Pressure (lbf/ft ²)	281,45	93,97	79,40	79,41	70,52	89,08	49,03
	Elev.(ft, NAVD)	13,0	13,0	13,0	13,0	13,2	13,2	13,2
p ₂	Pressure (lbf/ft ²)	149,94	31,92	5,79	5,79	0,00	21,30	0,00
	Elev.(ft, NAVD)	16,5	15,0	15,5	15,5	15,4	15,5	14,5
p ₃	Pressure (lbf/ft ₂)	186,81	35,76	0,70	1,50	31,89	5,63	31,71
	Elev.(ft,NAVD)	5,9	8,1	4,5	5,7	11,2	7,8	12,0
Top-of-wall SWL 100-Year Wave Dynamic Wave Force by Goda's Formula								
p ₁	Pressure (lbf/ft ²)	250,86	90,14	79,40	79,40	89,27	89,02	39,28
	Elev.(ft, NAVD)	16,5	15,0	15,0	15,0	15,5	15,5	15,5
p ₃	Pressure (lbf/ft ²)	130,79	20,38	0,20	0,42	11,19	1,31	7,94
	Elev.(ft, NAVD)	5,9	8,1	4,5	5,7	11,2	7,8	12,0
Corresponding Swing Gates (Stationnings of gate center)		NG-10 230+10	NG-6 210+59	SG-1 302+44	SG-2 307+58	SG-10 345+21	SG-11 349+74	SG-13 353+03
Note: waves loads are given as hydrodynamic pressures and does not include hydrostatic pressures.								
See the image below for p ₁ ,p ₂ ,p ₃ locations								

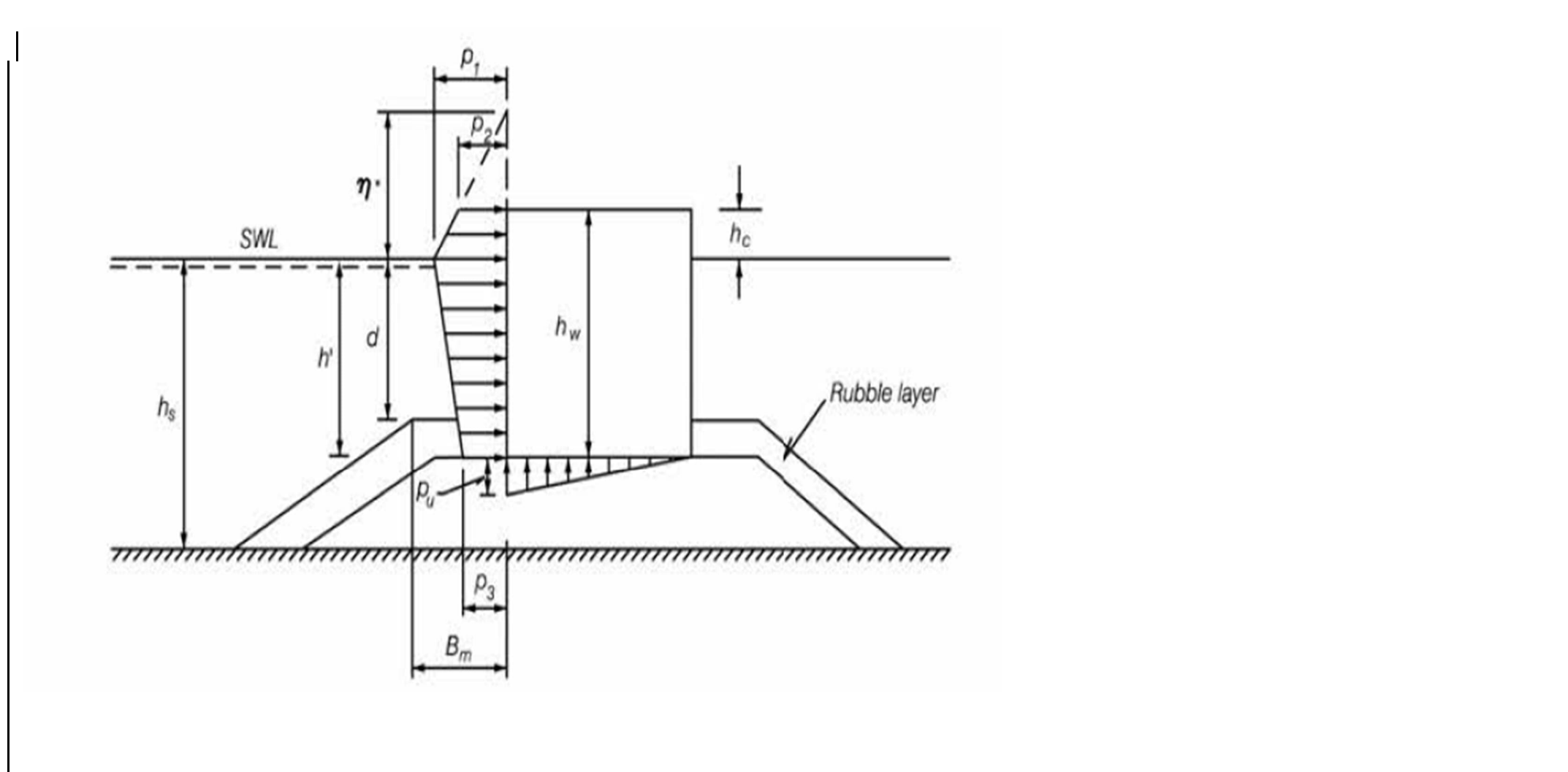

END OF SECTION 353131

NO TEXT ON THIS PAGE

SECTION 353132 – STOP LOGS AND APPURTENANCES

PART 1 - GENERAL

1.01 SUMMARY

- A. The Contract Documents provide a preliminary design of the stoplogs. The Contractor will be required to provide detailed design and calculations to the Architect/Engineer for review and approval prior to fabrication.
- B. Work included:
 - 1. Preparing and submitting detailed shop and installation drawings including detailed calculations and final design of the stoplogs for the Architect/Engineer's review as required in General Conditions Article 4.7.
 - 2. Provide and install all required stoplog panels, including seals, bearing bars, embedded guides and all other appurtenances included in the Contract Drawings and Specifications;
 - 3. Packaging and transportation of the stoplogs and appurtenances to the project site including all handling, permits and temporary storage of the stoplogs;
 - 4. All labor and equipment needed for the installation of the stoplogs and appurtenances;
 - 5. Preparing and submitting the operation and maintenance manual as required in Section 017823 and General Conditions Article 8.2;
 - 6. Shop testing of the stoplogs with their guides prior to delivery to the site;
 - 7. Provide and install steel stoplog storage racks (1 rack for each opening) including the anchors in concrete, the related padlocking devices of stored panels and all other auxiliary parts included in the Contract Drawings and Specifications;
 - 8. Electrically grounding the gate and frame;
 - 9. Site testing and commissioning by the Contractor;
 - 10. Services of the stoplog manufacturer's representative to assist the Contractor in the installation, testing and commissioning of the stoplogs.
 - 11. Providing the O&M training, training to be conducted by the stoplog manufacturer's representative and include classroom and field training. Training

is to be recorded in accordance with General Conditions Article 8.3. Training materials, handouts and agenda to be submitted to the Architect/Engineer for review and approval at least one month prior to any training.

1.02 PAYMENT

- A. All costs for Work required by this Section shall be included in the applicable lump sum(s), as set forth in Section 012901.

1.03 RELATED SECTIONS

- A. General Conditions Article 4.7 – Shop Drawings and Other Submittals.
- B. General Conditions Article 8.2 – Operations, Equipment and Maintenance Manuals.
- C. General Conditions Article 8.3 – Training.
- D. Section 012901 – Measurement and Payment.
- E. Section 014300 – Quality Requirements.
- F. Section 016100 - Control of Materials.
- G. Section 017700 - Contract Closeout.
- H. Section 017823 - Operation and Maintenance Manual.
- I. Section 031000 – Concrete Formwork.
- J. Section 033000 – Cast-in-Place Concrete.
- K. Section 051200 - Structural Steel.
- L. Section 055000 - Miscellaneous Metal.
- M. Section 099110 - Shop Painting.

1.04 CODES, STANDARDS AND OTHER PUBLICATIONS

- A. All stoplog shall be structural parts of the Resist Structure during operation and design according to sound engineering practice.
- B. For any discrepancy related to the stoplog design, the documents would supersede on another in the following order: the Codes, this Section, the Contract Drawings and the other standards and publications.

- C. If no year is indicated, the most up to date version of codes, standards, and other publications shall be used.
 - D. The publications listed below form a part of this Section.
 - 1. ASCE 7 – Minimum Design Loads for Buildings and Other Structures;
 - 2. Aluminum Association - Aluminum Design Manual
 - 3. USACE ETL 1110-2-584 – Design of Hydraulic Steel Structures;
 - 4. AWS-D1, D1.2, D1.3 & D1.6 – Structural Welding Code;
 - 5. ASTM F468 – Standards Specifications for Nonferrous Bolts, Hex Cap Screw, and Studs for General Use
 - 6. AISC – Codes, Specifications, Design Manuals and Steel Construction Manual;
 - 7. ASME Structural Welding Code Section IX;
 - 8. USACE EM 1110-2-2104 – Strength Design for Reinforced Concrete Hydraulic Structures;
 - 9. OSHA Regulations and standards.
 - E. The publications listed below form a part of this Section to the extent referenced. The publications are referred to within the text by the basic designation only.
 - 1. International Code Council (ICC), International Building Code, New-Jersey Edition.
 - 2. ASTM INTERNATIONAL (ASTM)
 - a. ASTM D 395 Standard Test Methods for Rubber Property - Compression Set.
 - b. ASTM D 471 Standard Test Method for Rubber Property - Effect of Liquids.
 - c. ASTM D 572 Rubber Deterioration by Heat and Oxygen.
 - d. ASTM D 2240 Standard Test Method for Rubber Property - Durometer Hardness.
- 1.05 SUBMITTALS
- A. Project Submittals
 - 1. Refer to General Conditions Article 4.7

- a. The Contractor shall prepare and submit for approval of the Architect/Engineer: document register / plan, quality plan, detailed schedule, general arrangement drawings, detailed calculations, technical data sheets, shop test procedures, installation procedures and commissioning test procedures. Drawings and calculations are to be signed and sealed by a New Jersey Professional Engineer.
 - b. The Contractor shall prepare and submit for approval of the Architect/Engineer: complete shop and assembly drawings and descriptive literature showing details of the stoplog guides, panels, padlocking system and storage facilities. Shop drawings shall indicate computed weights of each component listed above and approval of shop drawings will constitute acceptance of the computed weights shown on these drawings. Drawings and calculations are to be signed and sealed by a New Jersey Professional Engineer. Drawings shall also include, but not limited to:
 - (1) a detailed list including all components, parts or equipment to be purchased, with the same specifications that appear on the order forms of the stoplogs and appurtenances;
 - (2) the specification of materials;
 - (3) welding symbols;
 - (4) machining instructions;
 - (5) all tolerances and requirements for flatness, parallelism, orthogonality, hardness and surface finish;
 - (6) heat treatments (if required);
 - (7) non-destructive testing;
 - (8) bolt tightening instructions;
 - (9) painting instructions or any other corrosion protection system.
 - c. Contractor shall allow a minimum of 3 weeks for approval of shop drawings, calculations and other submittals.
2. Operations and Maintenance Manual Submittals
- a. Refer to General Conditions Article 8.2
 - b. Detailed operation and maintenance manual shall include, but not limited to, the following technical elements:

- (1) table of contents;
- (2) complete drawings list;
- (3) table summarizing the technical specifications of the components;
- (4) detailed description of the operation procedures of the equipment including deployment time;
- (5) list of preventive maintenance and inspections including the frequency of these inspections and maintenance operations;
- (6) troubleshooting section;
- (7) lubrication instruction, if required;
- (8) the list of spare parts;
- (9) detailed description of all components with assembly, adjustment and maintenance instructions;
- (10) copy of the purchase orders for all the components;
- (11) scaled 11x17 copy of all the drawings of assemblies and subassemblies.

1.06 QUALITY CONTROL

- A. Comply with the requirements of Section 014300.
- B. General: The Contractor is fully responsible for ensuring compliance with all tolerances required to achieve the performances included in the Contract Documents. The Contractor shall also establish and maintain quality control for stoplog operations to ensure compliance with Contract Documents and maintain records of his quality control for all construction operations including, but not limited to, the following:
 1. Ensure timely submittal of shop drawings.
 2. Inspection on delivery of fabricated items for damage, defects, and conformance with approved shop drawings.
 3. Installation in conformance with manufacture's recommendation and contract requirements.
- C. Reporting: The original and two copies of these records and tests, as well as corrective action taken, shall be furnished to the Construction Manager daily. Format of the report shall be agreed with the Construction Manager before submittal.

- D. Quality Plan: The Contractor shall submit for approval his detailed quality plan. The quality plan shall include descriptions of inspections and tests to be performed during the manufacturing, installation and commissioning.

1.07 WARRANTY

- A. Stoplog shall operate in accordance with Contract requirements and be free of defects in material and workmanship for a period of not less than three (3) years from the date of final acceptance.

1.08 DELIVERY, STORAGE, AND HANDLING

- A. Comply with the requirements of Section 016100.
- B. Deliver equipment with protective crating and covering.
- C. Store equipment to prevent damage and protect from weather, dirt, fumes, water, snow, ice and construction debris until final delivery date to the construction site.
- D. All stored or unsecured parts shall be locked to ensure security.

PART 2 - PRODUCTS

2.01 STOP LOG GATE DESCRIPTION

- A. Stoplog panels
 1. Structures: The panel structure shall be composed of aluminum alloys of closed profile section. Open profile section of panel is not allowed. Drainage holes may be also integrated in the panel structure. The number of panels used to close each opening shall be determined by the Contractor according to this Specification.
 2. Bearing bars: The hydrostatic loads and impact loads indicated in these Specifications shall be transferred from the panel structure to the Resist Structure Monoliths by the bearing bars.
 3. Seals: The seal path of installed panel shall be closed in order to achieve the sealing performance required by these Specifications and to obtain an uninterrupted seal path. The seals shall be preset enough to ensure proper sealing for any flood level below the top of the stoplog.
 4. Seals clamp bars: Seals shall be bolted on the panel with clamp bars as per the seal manufacturer's recommendations.
 5. Handles: Handles shall be attached to the panel in order to allow their manual handling. Handles shall be provided on both sides of each panel (upstream and

downstream sides). The number of required pairs of handles shall be determined according to the panel weight.

6. Latching devices: The panels shall be provided with latching devices for securing the panels in their installed and stored positions. The latching devices shall be heavy-duty and lockable.
7. Nameplates: The panels shall be provided with nameplates. Nameplates shall be approved by the Engineer.
8. The panel structure shall be provided with premium quality reflective warning signs on the full length and on both sides of each stoplog panel. These warnings signs shall be distributed onto the full panel length. The details of the warning signs and reflectors shall be agreed with the Construction Manager.

B. Embedded parts

1. Structure: The embedded parts (lateral guides and sill beam) are the metallic static structures embedded into the Resist Structure Monoliths and into the stoplog slab. The metallic static structures (embedded parts) consist of the assembly of the bearings and sealing surfaces with their respective supports and anchors. The lateral guides and sill beam shall be of fabricated stainless-steel components which incorporate the bearing and the sealing surfaces. Guides and sill beams shall not create a tripping hazard for pedestrians.
2. Bearing surfaces: The bearing bars of the panel transfer the loads to the bearing surface of the embedded parts, which are transferred to the Resist Structure Monoliths.
3. Side sealing surfaces: Leveled and continuous surface that shall ensure proper sealing with the panel side seals.
4. Sill sealing surfaces: Leveled and continuous surface that shall ensure proper sealing with the panel sill seals.
5. Panel bottom seal compressive device: If necessary, in order to reach the required sealing performances indicated in these Specifications, a device may be provided to compress the bottom seal of each panel when completely installed in their respective grooves.
6. Anchors: Anchors shall be injectable adhesive type (post-installed in the concrete) and /or cast-in-place anchors and shall be approved by the Engineer. The Contractor is responsible for the anchors that shall be installed and their design needs to rely on the concrete and rebar to resist pull out and prevent any other type of failure; the anchor design shall not require adding rebar to the concrete structure design indicated in Contract Drawings.

7. Interferences with rebar: The stoplog manufacturer shall coordinate his design with the Contract Drawings and with the Contractor to avoid drilling in rebar during anchors installation.
8. Concrete pouring: The stoplog slab (sill) and the concrete pier (side) consist in the first phase of concrete pouring. After their installation and alignment, the embedded parts supports and anchors shall be buried into the second concrete phase.
9. The installation and the use of intermediate posts are not allowed. The panels shall be designed to resist to the load combination indicated in these Contract Sections and to transfer these loads to the embedded part on both sides of panels.
10. When the stoplog panels are not installed in their respective grooves, a protective covering plate shall be securely fixed on the guides.

C. Storage Rack systems

1. Structure: The structure of the racks shall be composed of welded-fabricated aluminum Type 3004 or 6061-T6, which shall support the dead load of the stoplog panel when they are in stored position.
2. Anchors: Anchors shall be injectable adhesive type (post-installed in the concrete) and /or cast-in-place anchors and shall be approved by the Engineer. The Contractor is responsible for the anchors that shall be installed and their design needs to rely on the concrete and rebar to resist pull out and prevent any other type of failure; the anchor design shall not require adding rebar to the concrete structure design indicated in Contract Drawings.
3. Latching devices: The rack shall be provided with latching devices for securing the panels in their stored positions. The latching devices shall be lockable.
4. Nameplates: Each rack shall be provided with nameplates. Nameplates shall be approved by the Engineer.
5. The rack structure shall be provided with reflective warning signs on each ends of the rack. The details of the warning signs and reflectors shall be agreed with the Construction Manager.

2.02 ALLOWABLE STRESSES AND LOADS

A. General

1. The detailed design of stoplog embedded parts, panels and related racking systems shall be performed by using one of the following Methods indicated below:
 - a. Strength Design (Load and Resistance Factor Design – LRFD)

b. Allowable Stress Design (Allowable Strength Design – ASD)

B. Structural

1. Structural members shall be designed in accordance with Article 2.07.D.2.
2. The Resistance Factor (ϕ – LRFD) shall not exceed 5/6 of the one indicated in Article 2.07.D.2 and the Safety Factor (Ω – ASD) shall not be less than 6/5 of the one indicated in the same Standard.

C. Welded Connections

1. If applicable, structural welded connections shall be designed according with Article 2.07.D.2 and Article 2.07.D.4.
2. The Resistance Factor (ϕ – LRFD) shall not exceed 5/6 of the one indicated in Article 2.07.D.2 and the Safety Factor (Ω – ASD) shall not be less than 6/5 of the one indicated in the same Standard.

D. Bolted Connections

1. Structural bolted connections shall be designed in accordance with Article 2.07.D.2 and Article 2.07.D.5.
2. The Resistance Factor (ϕ – LRFD) shall not exceed 5/6 of the one indicated in Article 2.07.D.2 and the Safety Factor (Ω – ASD) shall not be less than 6/5 of the one indicated in the same Standard.

E. Concrete and anchors

1. Concrete and anchors: as per USACE EM 1110-2-2104.
2. Maximum allowable stress on the concrete: 1700 PSI.

2.03 ALLOWABLE DEFLECTIONS

- A. Maximum deflection of stoplog panel shall be of L/400 under Load Combination LC-1
- B. Maximum deflection of stoplog panel shall be of L/300 under Load Combination LC-2
- C. Allowable deflection may be smaller than these values because of the sealing or other detailed design criteria.

2.04 MINIMUM MATERIAL THICKNESS

- A. The minimum thickness of the stoplog panel structural components is 0.3125 inch.

- B. The minimum thickness of the embedded parts including the sealing and bearing surfaces plates is 0.25 inch after machining.
- C. The minimum thickness of the rack support component is 0.25 inch.

2.05 AMBIENT CONDITIONS

- A. The stoplogs shall be operated normally between 20 degrees F and 110 degrees F.
- B. The stoplogs shall be fully operative below freezing point.
- C. The stoplog shall be stored outside at a temperature between (-)10 degrees F and 120 degrees F.
- D. The humidity index can vary between 0 percent and 100 percent.
- E. The stoplogs or appurtenances shall not be damaged by ambient conditions, brackish water or salt water during flooding or storage.
- F. Overtopping water caused by waves shall not cause stoplogs operational issues such as excessive vibration and seal leaking.

2.06 LOAD CASES AND LOAD COMBINATION

- A. Loads

	Description	Direction (DIR) and value (VAL) to be applied
D	Self-weight load according to the final design	DIR: Vertical-Down; VAL: Depending to the final design;
Hs	Net differential hydrostatic water head across the stoplog panel	DIR: Horizontal-Downstream; VAL: Triangular loading diagram with a water head indicated in section 2.01 applied to the sill;
Hd	Wave load calculated as per the coastal model	DIR: Horizontal-Downstream; VAL: Trapezoidal loading diagram with a water heads as indicated in the <i>Protection Wall Wave Loading Table</i> ; See the Appendix A (at the end of this section);

	Description	Direction (DIR) and value (VAL) to be applied
IM	Impact load on the stoplog top panel due to the floating debris	DIR: Horizontal-Downstream; VAL: 500 pounds (lbs) per linear foot applied at the most unfavorable location on the full length of the stoplog panel;

B. Load combination

1. The following Load Combinations (LC) and related factors shall be applied:

- a. LC-1: $\gamma_D D + \gamma_L (H_s + H_d)$
- b. LC-2: $\gamma_D D + \gamma_L (H_s + IM)$

Factor	LRFD	ASD
γ_D (dead loads)	1.2	1
γ_L (live loads)	1.6	1

- 1. The stoplogs supply and its latching device shall be designed for wind up to 135 MPH with minimum safety factor of 2 on the yield strength of the materials. In this case, the stoplogs are installed and there is no flood.
- 2. Concrete and anchors: as per USACE EM 1110-2-2104.

2.07 MATERIAL GRADES, TYPES, AND CLASSES

A. General:

- 1. Metals and steels supplied shall be new and of the highest quality and shall conform to the minimum requirements of the material specifications specified. Specifications, mill certificates and Non-Destructive Examination (NDE) records shall be obtained for all metals and issued to the Construction Manager for the permanent record. These documents shall include, but are not limited to, unique item identification, chemical compositions/analysis and mechanical properties (yield and tensile strengths and elongation).
- 2. Dissimilar Materials: The assembly design and installation shall ensure that:
 - a. Aluminum shall be physically separated from concrete.
 - b. Dissimilar metals shall be physically separated.

3. Before starting fabrication, Contractor shall submit to Construction Manager the certificates of the tests executed in mill corresponding to the materials to be used.
 4. All materials indicated in these Specifications shall be in accordance with Section 055000.
 5. Contract between Aluminum-Alloys and Stainless Steel/Carbon Steel is not allowed in order to prevent galvanic corrosion. It shall be applicable for all supplies included in these Contract Sections:
 - a. Stoplog panels and other related auxiliary parts
 - b. Stoplog guides and other related auxiliary parts
 - c. Racking systems and other related auxiliary parts
- B. Materials for the stoplog panel shall be as follows:
1. Structure: Extruded and/or welded sheet/plate of Aluminum-Alloys 6061-T6.
 2. Bearing bars: The material shall be determined by the Contractor in order to avoid galvanic corrosion between panel/bearing bars and bearing bars/bearing surface (guide).
 3. Seals clamp bars: Sheet/plate of Aluminum-Alloys 6061-T6.
 4. Latching devices: Sheet/plate of Aluminum-Alloys 6061-T6.
 5. Structural and seal fasteners (Bolts, nuts and washers): Nonferrous Bolts, ASTM F468. The material shall be determined by the Contractor in order to avoid galvanic corrosion between fasteners and stoplog panel.
- C. Materials for the embedded parts shall be as follows:
1. Guide Structure, including bearing and sealing plates: ASTM A276 Type 304 Stainless steel.
 2. Embedded Anchors: ASTM A325.
 3. Semi-embedded Anchors: ASTM A276 Type 304 Stainless steel.
- D. Materials for the racking systems shall be as follows:
1. Structure: Extruded and/or welded sheet/plate of Aluminum-Alloys 3004 or 6061-T6.
 2. Embedded Anchors: ASTM A325.

3. Intermediate Material: The material shall be determined by the Contractor in order to avoid galvanic corrosion between the stored panels and the rack structure.
4. Latching devices: The material shall be determined by the Contractor in order to avoid galvanic corrosion between latching device and stoplog panel.

E. Stoplog seals

1. Stoplog seals shall be molded or extruded only and the material shall be compounded of natural rubber or polyurethane.
2. The seals shall be attached to the bottom and ends of each panel in order to provide an uninterrupted seal path.
3. All holes in the panel seals shall be drilled as per manufacturer's recommendations.
4. Seals hardness shall be selected as required for the application.
5. Seals materials shall be tested as per applicable ASTM standards.

2.08 OPERATING CONDITION REQUIREMENTS

A. There are 2 different opening widths:

1. TYPE A: 6 ft span:
 - a. NG-3; 4 ft height
2. TYPE B: 10 ft span:
 - a. NG-1; 3.5 ft height

B. Each of these openings shall be watertight closable using stoplog panels. The number of panels used to close each opening shall be determined by the Contractor and shall depend on the maximum weight of 80 pounds per panel. The total height of the installed stoplog panels in their respective grooves are indicated above.

C. The stoplog panels shall be installed and removed in their respective grooves in dry conditions.

D. The stoplog groove components shall be embedded in concrete as shown on the Contract Drawings.

E. The stoplog panel storage locations are shown on the Contract Drawings. They shall be stored on steel racks anchored in concrete specially designed and provided for this purpose. The stored stoplogs shall have a minimal clearance of 2 inches above the ground level.

- F. The stoplog panels shall be latched and padlocked in both positions:
 - a. When stored in their respective positions
 - b. When installed in their respective grooves
- G. The stoplog panel storage footprint shall be minimized.
- H. Flood Event
 - 1. No stoplog components shall have to be replaced due to flooding on the exterior side of stoplogs, except for normal wear and tear items.

2.09 MAINTENANCE REQUIREMENT

- A. All components shall be easily accessible for visual inspection and maintenance and shall conform to Section 017823.
- B. All components that may be replaced, including the stoplogs seals, shall be easily replaceable.
- C. The maintenance requirements are applicable only when the stoplog panels are not installed in their respective grooves.
- D. All padlocks provided for the stoplogs and gates shall be keyed identically, Contractor to provide a minimum of 4 sets of keys for each closure padlock.

2.10 DESIGN LIFE

- A. The stoplog supply design life shall be:
 - 1. 50 years of operation for the embedded parts and permanent storage racks
 - 2. 50 years of operation for the removable panels
- B. This design life takes into consideration normal maintenance. The supply shall not require major rehabilitation or major replacement during this design life.

2.11 HEALTH, SAFETY AND ENVIRONMENT REQUIREMENTS

- A. The stoplogs and appurtenances shall conform to OSHA 29CFR1910 regulations.
- B. Stoplog components shall not to contain any hazardous materials.

2.12 OTHER REQUIREMENTS

- A. Operating conditions

1. The stoplogs and appurtenances shall be designed in a way to avoid being damaged when not deployed. Stoplog guides shall not be damaged by vehicular traffic, machinery and snow removal machinery.
 2. The supply shall be designed and shall be provided with the required adjustments to allow proper stoplog panel installation and removal, alignment, latching and sealing.
 3. When not deployed, stoplog panels shall be stored as shown on the Drawings.
 4. Locking devices shall be provided for stoplog panels when installed in their respective groove and in their respective storage rack.
- B. Sealing performance
1. The maximum leakage rate of stoplog panel shall be of 0.05 gal/(min*ft of wetted seal) under the full hydrostatic load. This sealing performance shall be achieved when the adjacent panel is laterally offset up to 0.5 inch.
- C. Handling operation
1. The number of stoplog panels which shall be used to close the total area of each opening shall be determined by the Contractor according to the maximum weight of 80 pounds per panel.
- D. Grounding
1. Refer to Section 260526.
 2. The Embedded parts shall be grounded by being connected to a ground rod as shown in drawing E504. The types of connection and solder used are also shown in drawing E504 and described in Section 260526.

PART 3 - EXECUTION

3.01 ENGINEERING AND DESIGN

- A. All engineering documents shall be signed by a Professional Engineer of the New Jersey State.
- B. The Contractor shall submit for approval to the Architect/Engineer all project documents including the documents included in Paragraph 1.05 “Submittals”.
- C. The Contractor shall not proceed with the Work included in a project document without the formal approval of project document by the Architect/Engineer.

- D. The Contractor is responsible for coordinating the location and installation of all parts of the stoplog system. These parts include, but are not limited to, the panels, guides, embedded parts and storage.
- E. Any equipment design which impact the Resist Structure shall be strictly coordinated by the Contractor with the stoplog manufacturer. These include, but are not limited to, the anchoring system, embedded parts and storage racks.
- F. Any modifications to the concrete foundation or pilasters resulting from the Contractor's stoplog design, will be done at the Contractor's cost. Any design changes to the concrete structures or other Project components needs to be reviewed and approved by the Architect/Engineer.

3.02 WORKMANSHIP

- A. All metalwork fabrication and machine work shall comply with Section 055000.
- B. All machined surfaces shall meet the minimum tolerances (e.g.: flatness, parallelism, squareness, surface finish) to achieve the required performance.
- C. The manufacturer shall provide access to the State to its shop facilities for inspection of materials, testing, and workmanship. Refer to Section 14300 for requirements.
- D. Machined surfaces inspection shall not be performed using the machine tool which was used to machine the inspected part.

3.03 SHOP TEST

- A. Each stoplog shall be completely assembled in the shop together with their respective guides and sill. Dimensional checks shall be made and recorded and tolerances shall be within values specified in the fabrication drawing.
- B. A certified test report sealed and signed by a State of New Jersey Professional Engineer shall be provided by the Contractor.

3.04 INSTALLATION

- A. The Contractor shall prepare for approval the installation drawings and detailed procedures including the required installation tolerances. The installation drawings shall include, but not limited to, the following:
 - 1. A detailed list including all components, parts or equipment to be purchased, with the same specifications that appear on the order forms. This list shall also include each subassembly, identified by its drawing number;
 - 2. welding symbols;

3. all tolerances and requirements for flatness, parallelism, orthogonality;
 4. non-destructive testing;
 5. bolt tightening instructions;
 6. painting instructions or any other corrosion protection system.
- B. The stoplog manufacturer shall provide the services of a competent technical supervisor during each stoplog supply installation. The technical supervisor shall ensure that the stoplog manufacturer requirements will be met during the installation. Contractor shall provide 8 hours (onsite) for a technical supervisor per stoplog for installation, testing and commission of the stoplogs. Time does not include travel time for the representative.
- C. The Contractor shall coordinate the supply of the embedded parts and the balance of the stoplogs according to the Contractor approved Construction Schedule.
- D. The installation tolerances of the embedded vertical bearing/sealing bar on each side monolith of the stoplogs shall be coordinated between the Contractor and the stoplog manufacturer to ensure optimum functionality and sealing.

3.05 COMMISSIONING

- A. The Commissioning procedure shall be approved by the Architect/Engineer.
- B. After erection and before final acceptance, the minimum following tests and adjustments shall be performed in order to demonstrate to the satisfaction of the Construction Manager that the stoplogs have been properly installed and adjusted as required by the Contract Drawings and Specifications:
1. Each stoplog panels shall be installed and removed in their respective grooves, one by one from the top to the sill beam:
 - a. All panels move freely by hand from on the whole height of operation
 - b. There is no contact between the stoplog panel structure and the guide/sill beam (embedded parts)
 2. The complete set of stoplog panels shall be installed to completely close their respective opening. Then, the panel seal compressive device (if required) and the latching device shall be installed and adjusted. A visual inspection shall be performed:
 - a. Seals are well pre-compressed in order to form a watertight barrier across the stoplog structure

- b. No contact between the stoplog panel structure and the guide/sill beam (embedded parts)
 - 3. The complete set of stoplog panels shall be installed in their respective racks (stored position) and the latching device shall be installed and adjusted. A visual inspection shall be performed:
 - a. No contact between the stoplog panel structure and the rack structure
 - C. Any defects disclosed during tests shall be promptly corrected without additional cost to the NJDEP and the tests repeated until the stoplogs has satisfactorily passed the tests. No separate payment will be made for testing and adjusting the stoplogs.
- 3.06 SPARE PARTS AND SPECIAL TOOLS
- A. The Contractor shall provide one set per stoplog, any special tools required to operate or maintain the stop log gate.
 - B. The Contractor shall include in his maintenance and operation manual a manufacturer recommended spare parts list and current price list.
- 3.07 CONTRACT CLOSEOUT
- A. Provide in accordance with Section 017700.

Appendix A: Wave Loads Table

RBDH - Protection Wall Wave Loading Corresponding to StopLog Locations - Rev.A			
* All wave loading values come from Coastal Engineering Team document on 2019, November 18 th			
		A3N9	A3N9
10-Year SWL 100-Year Wave Dynamic Wave Force by Goda's Formula		Begin ~ End 200+00 ~204+20	Begin ~ End 200+00 ~204+20
P ₁	Pressure (lb/ft ²)		
	Elev.(ft, NAVD)		
P ₂	Pressure (lb/ft ²)		
	Elev.(ft, NAVD)		
P ₃	Pressure (lb/ft ²)		
	Elev.(ft, NAVD)		
100-Year SWL 100-Year Wave Dynamic Wave Force by Goda's Formula			
P ₁	Pressure (lb/ft ²)	48,68	47,87
	Elev.(ft, NAVD)	13,1	13,0
P ₂	Pressure (lb/ft ²)	0,00	0,00
	Elev.(ft, NAVD)	14,4	14,1
P ₃	Pressure (lb/ft ²)	32,77	40,75
	Elev.(ft, NAVD)	12,0	12,0
Top-of-wall SWL 100-Year Wave Dynamic Wave Force by Goda's Formula			
P ₁	Pressure (lb/ft ²)	39,91	42,51
	Elev.(ft, NAVD)	15,5	15,0
P ₃	Pressure (lb/ft ²)	8,07	24,85
	Elev.(ft, NAVD)	12,0	12,0
Corresponding StopLogs (Stationnings from 2019, November 18th)		NG-1 202+50	NG-3 204+13

See the image below for p₁, p₂, p₃ locations

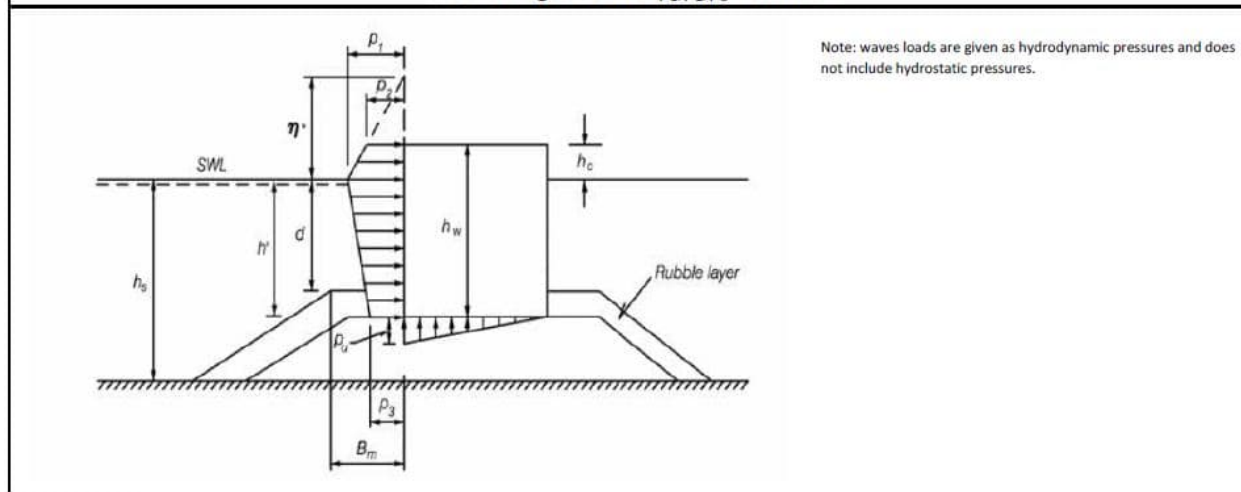

END OF SECTION 353132

NO TEXT ON THIS PAGE