



Vapor Recovery Inspections

At Gasoline Dispensing Facilities
(GDFs)

Mike Hollis – UST Inspection Program

Stage I Vapor Recovery

A system designed to capture displaced vapors that emerge from inside a storage tank when a load of gasoline is delivered into the tank. During the filling process, the rising liquid displaces the vapors present in the upper portion (ullage) of the tank. These displaced vapors have to escape to enable the product transfer to the tank. If there is not a tight connection (tight fill) between the delivery hose and the fill port, some vapors flow out around the hose while additional vapors escape through the tank's vent pipe. The Stage I VRS is designed to capture said vapors that result from the gasoline transfer from the delivery truck to the storage tank.

Stage I VRS: Single Point and Dual Point.

Single Point systems utilize a co-axial drop tube which consists of a "pipe within a pipe". Again, this device is in the drop tube located at the tank's fill port. Typically, there is a poppet valve in the co-axial drop tube which is normally closed which prevents the escape of vapors from the storage tank when the toggle cap is opened. The product enters the tank through the center (inner) pipe and the tank vapors are returned to the tanker through the outer pipe. Since only one fill/vapor recovery port is present, this type of system is called a "one point or single point". The delivery is through one fill unit which has two hoses connected to it. One hose conducts the fuel from the tanker truck to the tank; the second hose returns the displaced vapors to the truck's compartments.

Dual Point systems utilize two separate tank ports for delivery and vapor recovery; hence the name Dual Point. The first port is the fill port drop tube. The delivery unit is attached to the drop tube and a hose from the tanker transfers fuel to the storage tank. The vapor recovery port is called a "Dry Break" (commonly painted orange) and it consists of a riser and a spring loaded poppet valve which is normally closed. During a fuel delivery, a vapor recovery device is attached to the dry break which automatically opens the poppet valve. The vapor return hose routes the vapors from the tank through the dry break and back to the tanker.

Stage II Vapor Recovery

The Stage II system is designed to capture displaced vapors that emerge from inside a motor vehicle fuel tank, when gasoline is dispensed into the tank. Gasoline vapors accumulate in automobile and truck tanks, above the liquid level. When the vehicle tanks are filled, the rising liquid forces these vapors to seek an escape route, typically to the atmosphere. When a conventional nozzle is used (no Stage II provisions), the displaced vapors flow out around the nozzle and into the air.

There are two basic types of Stage II VRS:

The **Balance System**, the most commonly encountered type, transfers vapors from the vehicle tank to the station's lowest octane grade storage tank (typically, Regular Unleaded) without the assistance of an external force, such as a vacuum pump (venturi or electric). The key feature in the balance system is a hose nozzle that makes a tight connection with the fill pipe on the vehicle gasoline tank. The nozzle spout is fitted with an accordion-like bellows that presses snugly against the fill pipe opening. Balance systems are designed with controls that prevent fuel from flowing into the vehicle unless there is a tight connection between the bellows and the vehicle fill pipe. When fuel delivery begins, gasoline flows from the dispenser into the vehicle fuel tank. Vapors displaced by the rising liquid seek an escape route through an open port in the nozzle bellows. From this port, the vapors flow through the coaxial dispenser hose to the vapor-return piping of the gasoline tank. This recovery of the vapors is accomplished without the employment of external force. The withdrawal of vapors from the vehicle tank is balanced by the simultaneous addition of the vapors to the underground tank from which the gasoline is being dispensed—hence the name, *balance* system.

The **Vacuum Assist System** utilizes a mechanical device to establish a vacuum to pull the vapors back to the underground tank. The vacuum can be generated by either an electric vane pump or a venturi device such as the Healy Mini-Jet that uses pressurized gasoline to produce a vacuum. Vacuum assist most commonly use the electric vane pumps, typically painted blue, and located in the dispenser housing. They operate during a fuel delivery to a vehicle and pull the gasoline vapors from the tank and through piping route the vapors to the underground tank. The vacuum assist dispenser hose is smooth on the outside, not corrugated like the balance system hose. There are several holes in the nozzle end, while balance systems use only a single hole.

Stage I Vapor Recovery

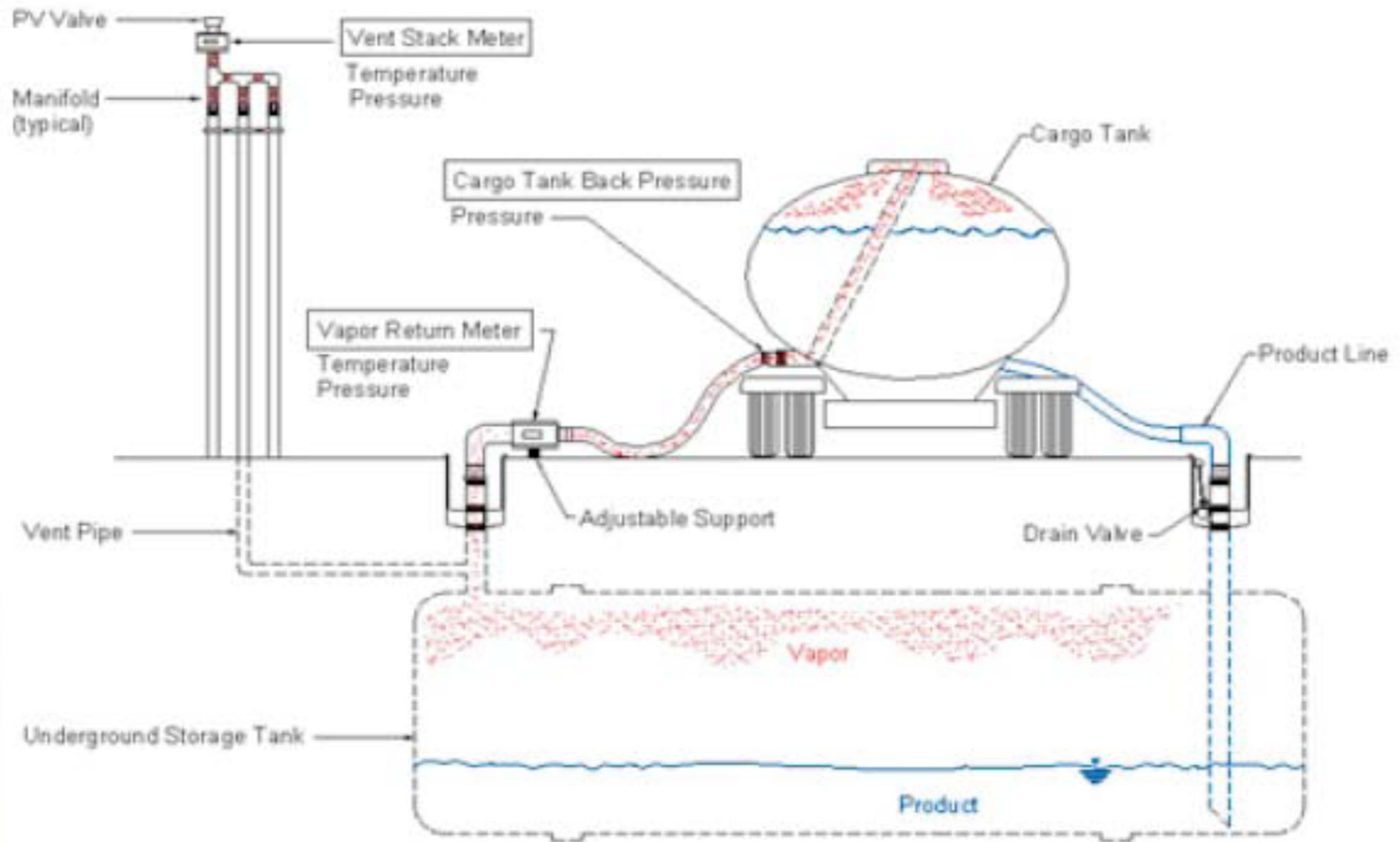

Stage I Vapor Recovery

NJAC 7:27-16.3(c)&(d)

- Required for gasoline tanks 2,000 gallons or greater in capacity
 - Delivery **MUST** be made through a submerged fill pipe
 - Storage Tank **MUST** be equipped with one of the following emission controls:
 - A Pressure/Vacuum relief valve must be installed on the vent *and*
 - System must reduce the total VOC emissions into the outdoor atmosphere by no less than 98% (this corresponds with CARB's Phase I EVR standards)
- OR
- A floating roof

Two-Point Delivery



This is your typical delivery at a facility that has dry breaks. If you witness a delivery, make sure the hose has a tight seal with the dry break to prevent a vapor discharge.

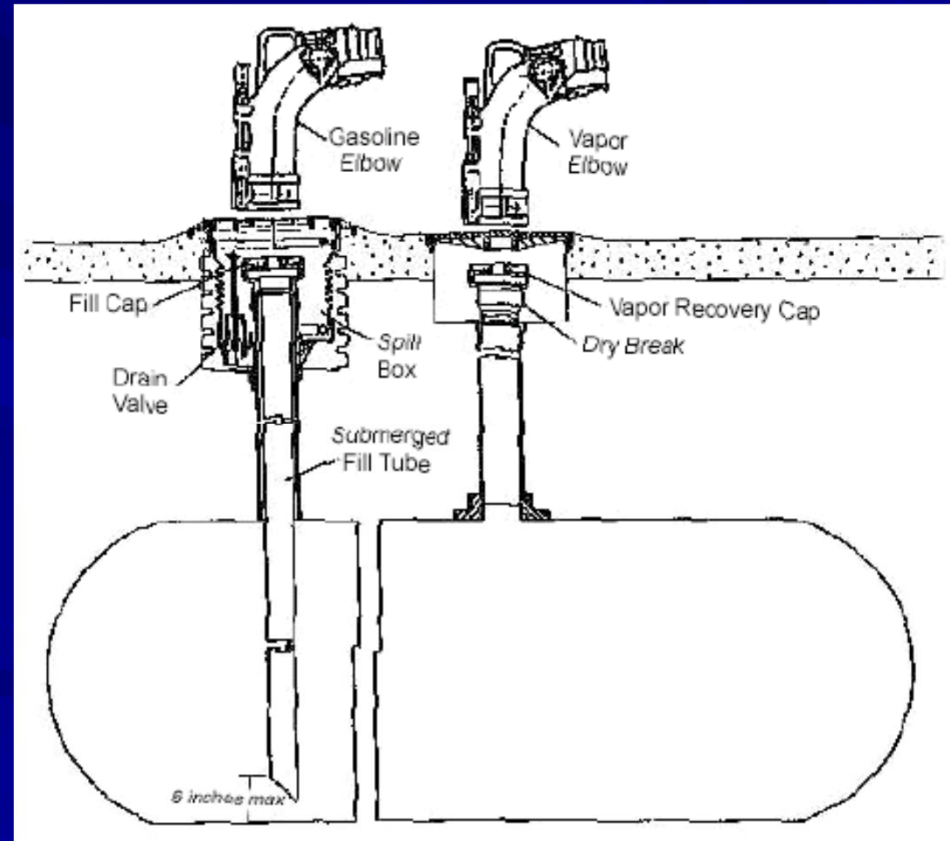

Some GDFs have manifolded vapor recovery, or ONE dry break for multiple tanks. That is the only case where one vapor connection is acceptable for multiple tanks!

Dry Break

aka "Poppet Valve"



Here is a typical dry break. Make sure this valve is in the closed position. Also, try to depress the valve, as it should spring back up when you release it. If this is frozen in the open OR closed position, it's a violation and the tank should not take deliveries until it is repaired/replaced according to 7:27-16.3(d)

Dry Break Problem?



Before



After

Both are violations, the one on the right is just comical.

More Dry Break Issues...



This is a very common and illegal practice. In order to make their delivery faster, some tanker operators do not hook up their stage I hose to the dry break, and instead prop it open with something, usually a screwdriver, pebble, or even the dust cap. If you come across this in the field, stop the delivery until the operator hooks up his hose to the dry break.

One-Point (Coaxial) Deliveries

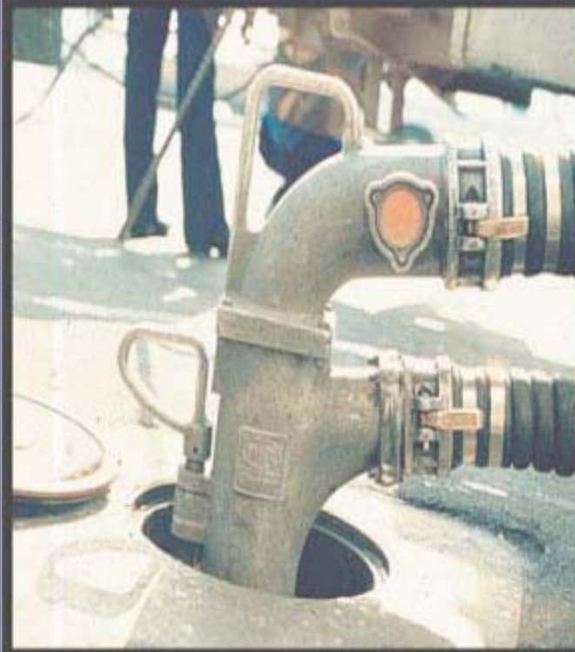

One Point Coaxial

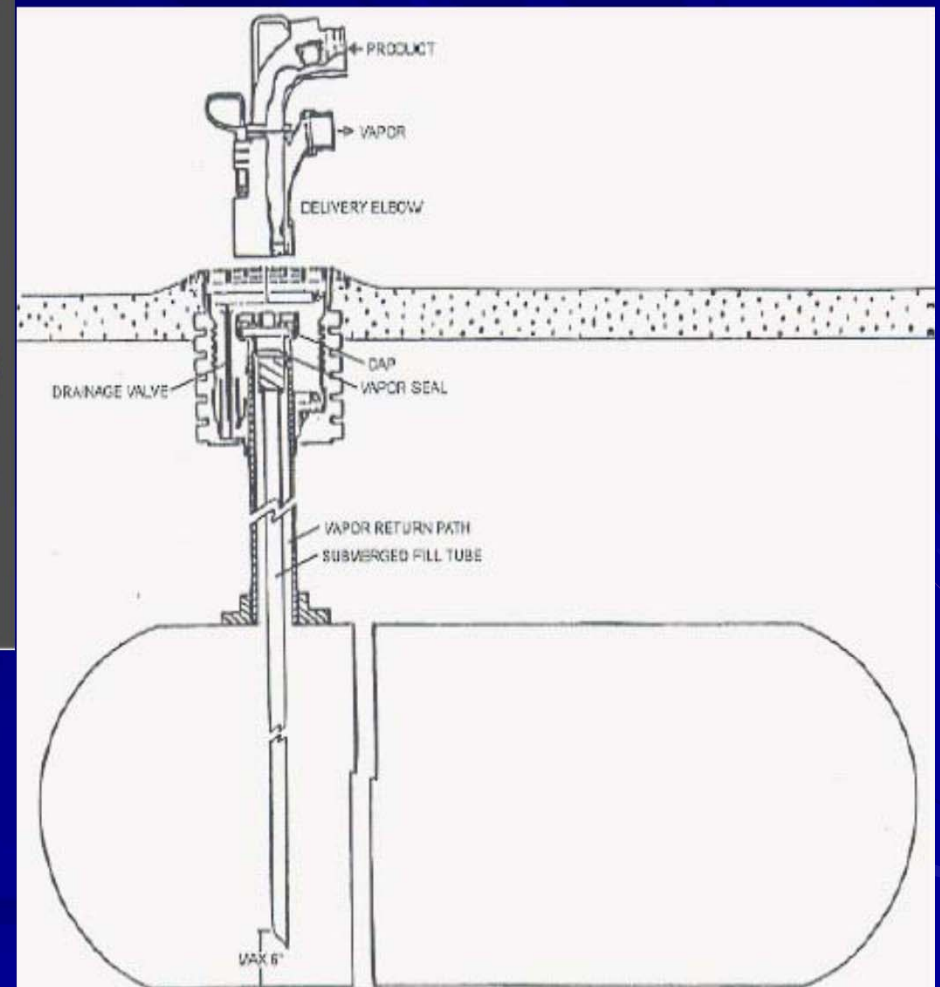

Delivery is made with a double-hose through one connection. Product is on top then through the middle of the connection, vapor is on bottom then around the outside of the connection.

Poppeted Coaxial



Pressure/Vacuum Valves

Three vent lines manifolded into one.



Three unmanifolded vent lines with three P/V Valves.



These valves are installed on top of the vents to prevent vapors from being released into the atmosphere. Current regulations require a CARB approved P/V valve to crack at 3" H₂O of positive pressure and 8" H₂O of vacuum (+ or - 1/2"). **NOTE: Federal regs as of 2009 require pressures of 2-6" positive and 6-10" negative**

Pressure/Vacuum Valves?



This is a homemade P/V valve, it has a much lower cracking pressure than the CARB approved ones. Systems like this are obviously not permitted.

Pressure/Vacuum Valves?



Once again, just when you thought you've seen everything, you find a joker like this. Somehow, these gloves are not in compliance with the required cracking pressure of a real P/V valve. According to NJAC 7:27-16.3(d), a delivery can not be made to these tanks. The weather cap on the diesel vent is fine.



Stage II Vapor Recovery

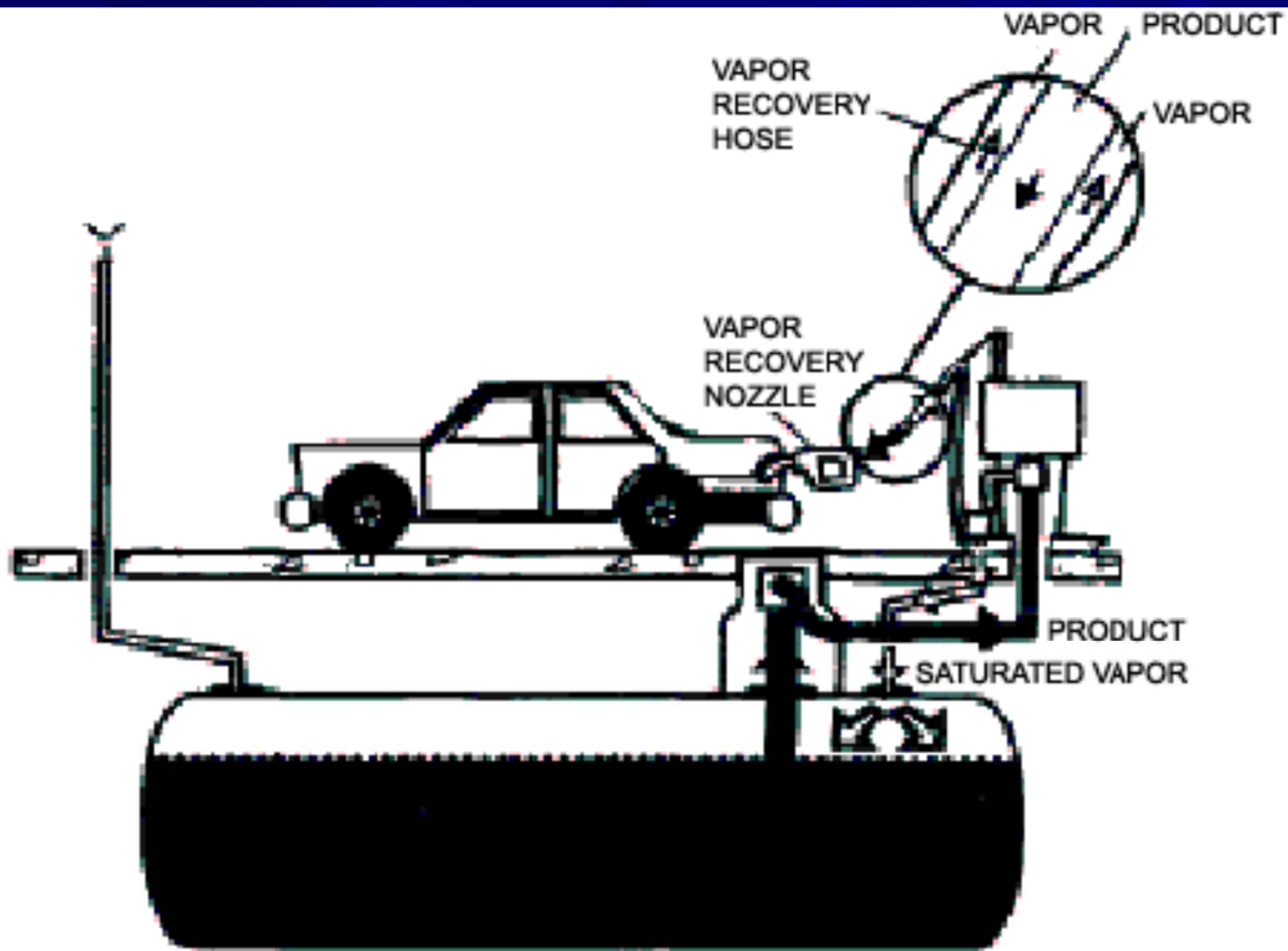

Stage II Vapor Recovery

NJAC 7:27-16.3(e)&(f)

- Facilities with a monthly throughput of 10,000 gallons or greater, and all new facilities constructed after June 29, 2003.
- System must have a collection efficiency of 95%
- System must prevent overfilling and spillage
- Airports and marinas are exempt. Why?
- Systems installed on or after June 29, 2003 must be a unihose dispensing system.
- Nozzles must fit into the dispenser housing properly, with the check valve remaining closed.
- If a facility is exempt from Stage I, they are also exempt from Stage II

Stage II Components



What to look for:

What kind of Stage II system?

Tears/holes in hoses or nozzles

Are all components installed in the correct direction?

Is any part of the hose laying on the ground?

Does the nozzle fit in the holster?

Is the nozzle check valve functioning?

Balance vs. Vac Assist

Standard Coaxial Hose



Inverted Coaxial Hose



The difference between the two types of system hoses is apparent. The balance hose is thicker and ribbed, while the vac assist hose is smooth and thinner.

The inner workings of the two hoses are inverted. A balance hose has the vapor path on the outside, while the assist hose has the product path on the outside.

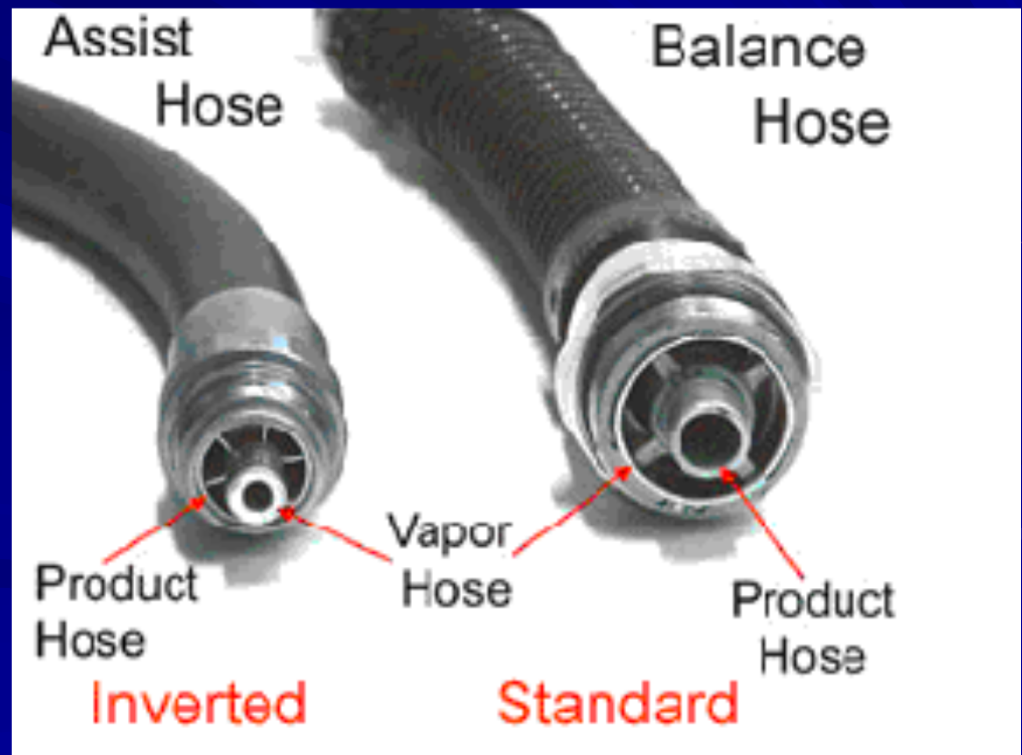

Balance System

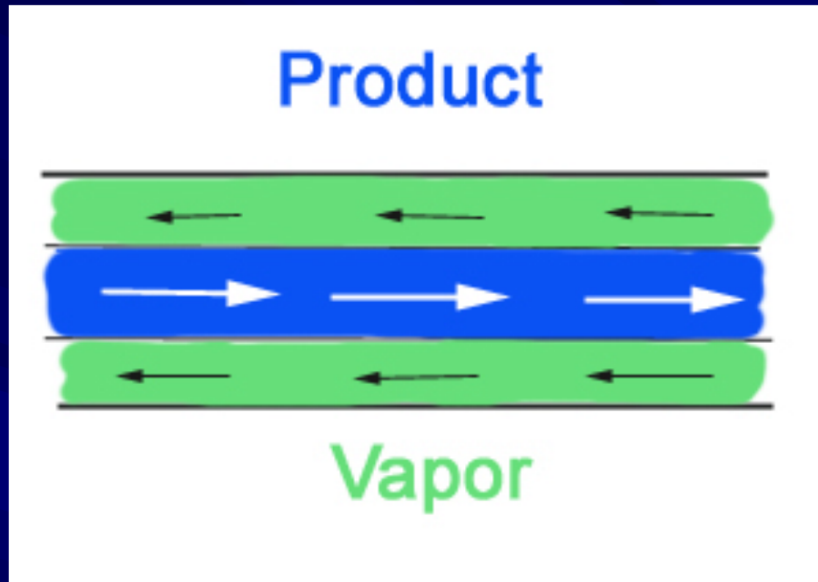

A balance system has the product flowing through the middle in one direction, and the vapor along the outside in the opposite direction. This is a passive system that relies on the slight pressurization of the vehicle gas tank gaining product, along with the vacuum created by the UST (or AST) losing product. This system is compatible with any Stage I system.



Balance Nozzle

Check for tears or holes in the bellows and faceplate. Also test the check valve to make sure it is opening/closing. To test for a liquid blockage, simply hold the nozzle out downward with the hose over your shoulder, point the nozzle into a bucket, and pull open the bellows to open the check valve. If gasoline pours out of the bellows, it's likely the station is topping off.

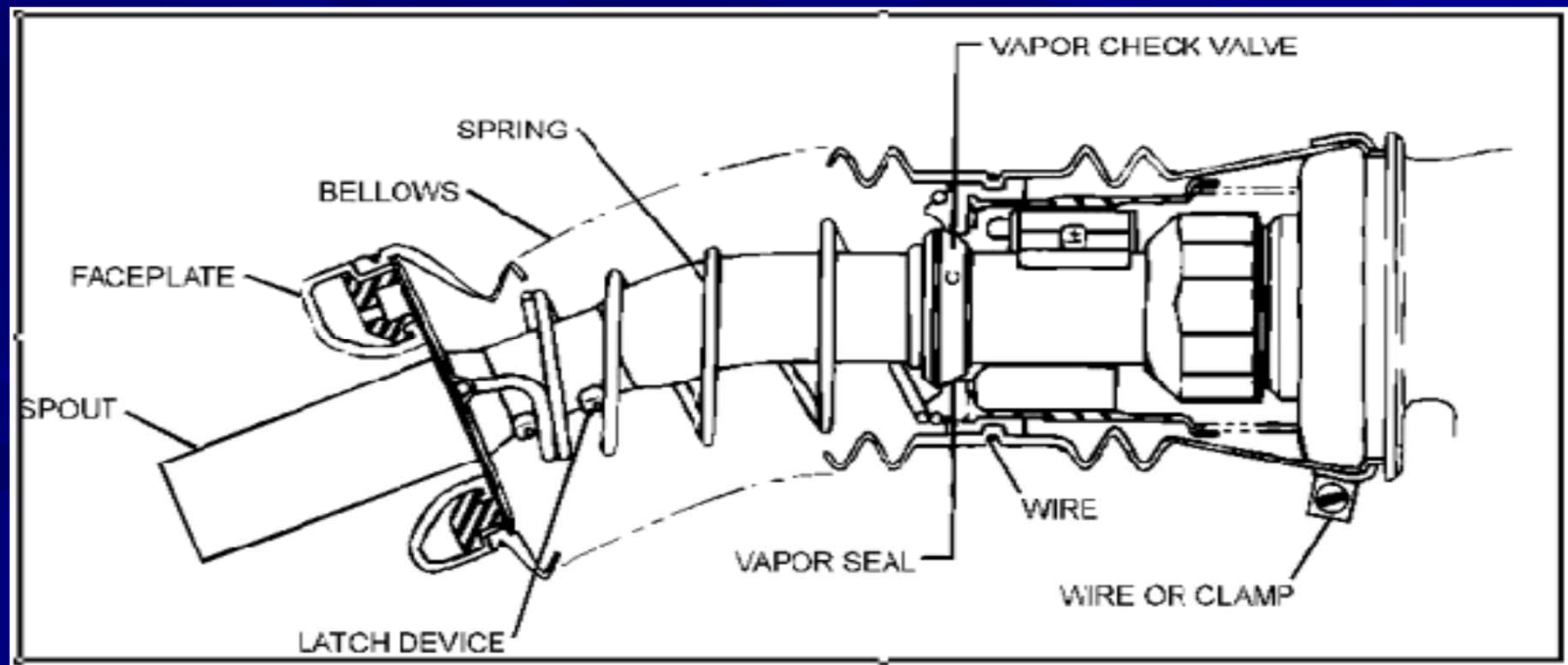

Balance Nozzle

Emco w/ an external check valve



This is a common Emco balance nozzle. The check valve opens/closes the vapor path to the rest of the Stage II system. It is opened when the bellows are engaged/pulled back (see picture to the right). Check to make sure that this valve opens and closes properly. Some nozzles have internal check valves instead, which can't be inspected.

Balance Nozzle

Balance Nozzle
Note-
Face Plate
for positive
seal



Perhaps the most common part of the balance system to find holes/tears is in the face-plate. This occurs due to normal wear and tear from being constantly shoved against vehicle gas tanks. Any failures of this part of the device could result in there not being a tight seal during the fill and a vapor release.

Balance Nozzle

Speaking of torn face-plates.....

Also notice the hole on the underneath part of the spout in this picture. This is the automatic shut-off for the nozzle. Once fuel reaches this hole, the nozzle will click off, preventing a vehicle overfill. Check to see if this is clogged or damaged.



Balance Violations

OOPS!!



Weathering, dry-rot, or severe neglect can render the system inoperable. It is the facility's responsibility to maintain their equipment and replace any defective or damaged parts.

Violation?

OMG! No Stage III!!



No. Diesel fuel, which is NOT classified as a VOC, does not require any kind of vapor controls. However, we'd prefer to not see the hose in a position where vehicles can run it over.

Balance Violations

Nice Hose!!



These cracks are likely the cause of weathering and an irresponsible O/O. Get them replaced. Stage II equipment must be 95% effective, so any equipment failures will result in that number being diminished.

Balance Violations

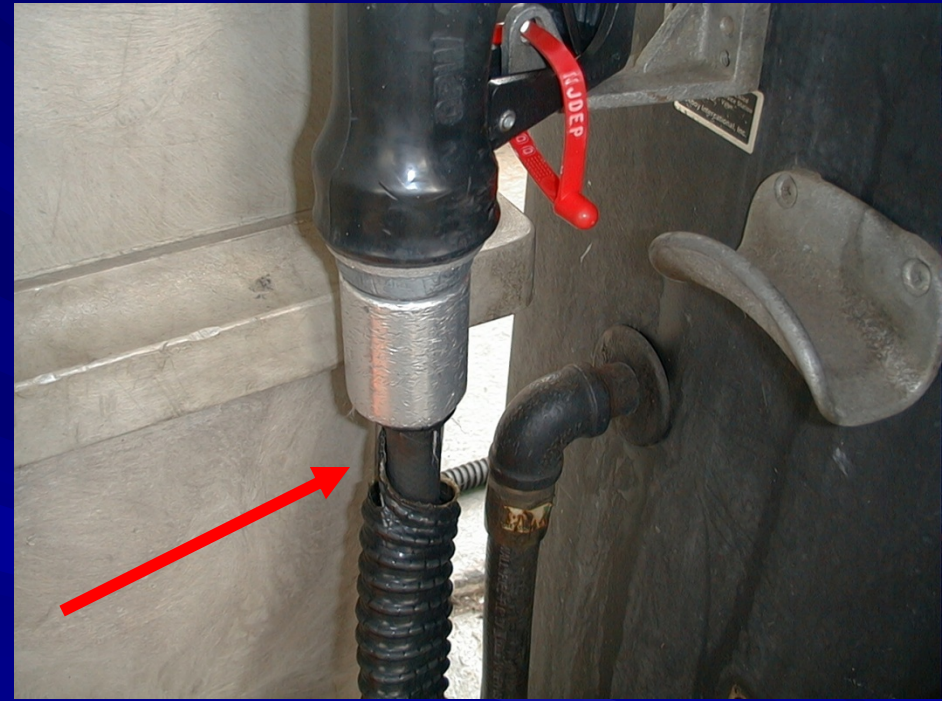

Amazingly, this equipment is not functioning. GDFs with General Permits are required to visually inspect their equipment and keep a log **DAILY!** There are no excuses.

Vacuum Assist System

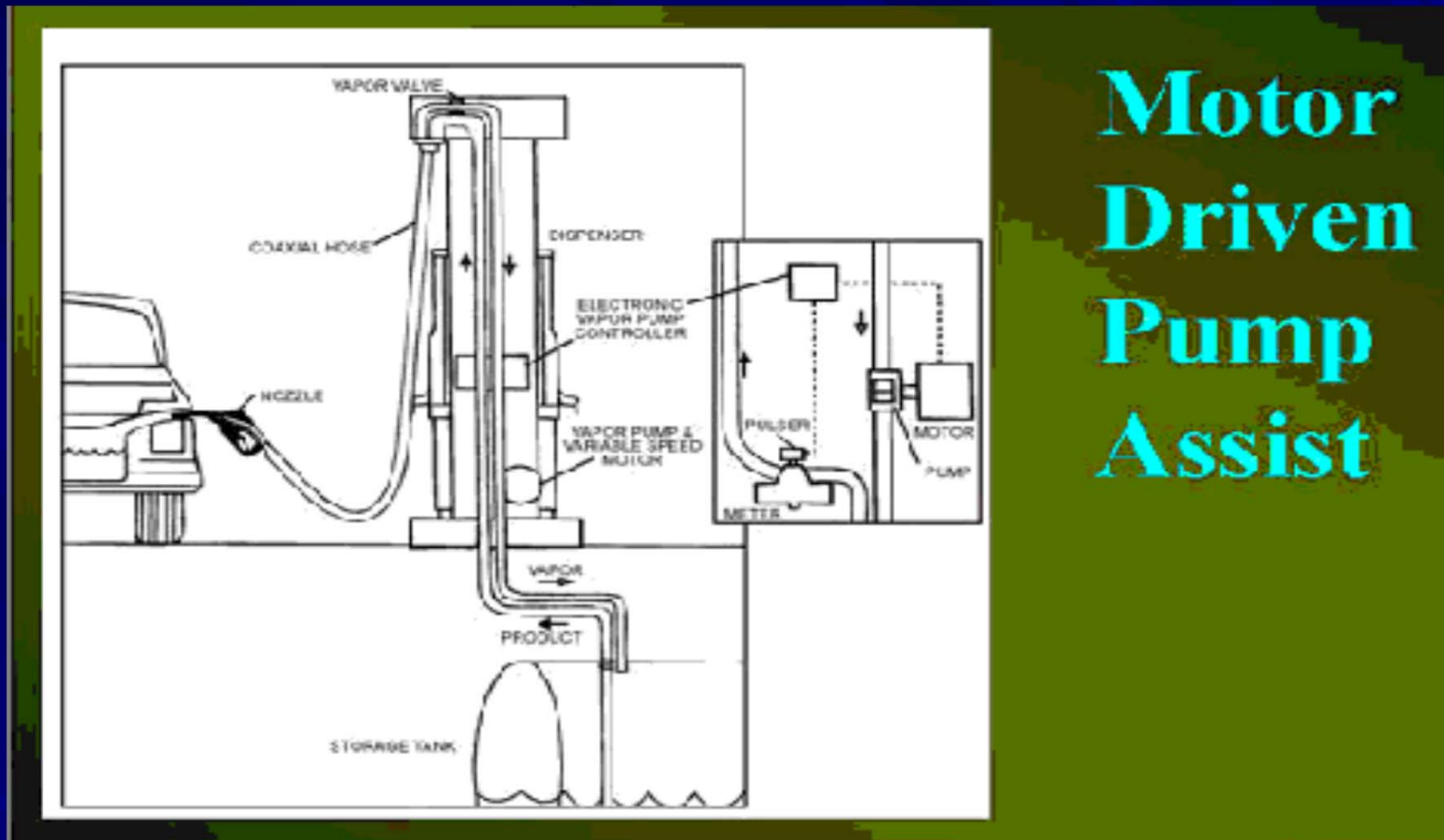

**Motor
Driven
Pump
Assist**

The diagram above shows a vacuum assist recovery system. The system pulls the vapors from the vehicle's fuel tank into the UST using a pump. The vapor pump may be fluid driven, motor driven, or electronically driven. The pump, or pumps, are usually located within the dispenser.

Vacuum Assist

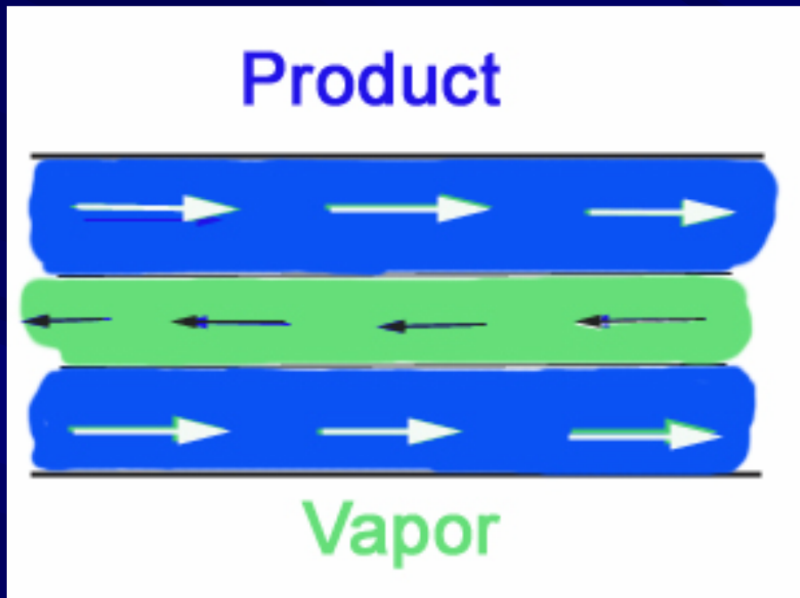

Vacuum Assist equipment differs from balance substantially. The product and vapor flow is inverse from balance in the hose, so any kind of hose failure is even more dangerous. Vacuum Assist is only compatible with two-point Stage I systems, although some facilities in NJ still try to use it with coaxial Stage I.

Vacuum Assist nozzles also appear and operate very differently from a balance system. Gone are the faceplate and bellows, as this system can NOT have a tight seal with the vehicle tank. This active system pulls vapor from the vehicle tank through the holes near the end of the spout.



Vacuum Assist

Here is a better view of a typical Vacuum Assist nozzle. Notice the larger holes which pull in the vapor. Also notice the metal flap about half-way down the spout, this is the latching device that holds the nozzle in place while it is in-use.



Notice this nozzle has a splash-guard. The sole function of this is to prevent spillage during a delivery, it has no vapor recovery function. However, this is required in NJ. Other nozzles do exist without splash-guards, but they are not permitted to be used in NJ.



Vacuum Assist



The arrow on the hose pointing out flow direction is not restricted to only Vac Assist systems. Just make sure it's pointing the correct way! Believe it or not, some people can't follow that simple instruction. Note the difference in appearance between the Vac Assist hose and the balance hose shown earlier.

Vacuum Assist

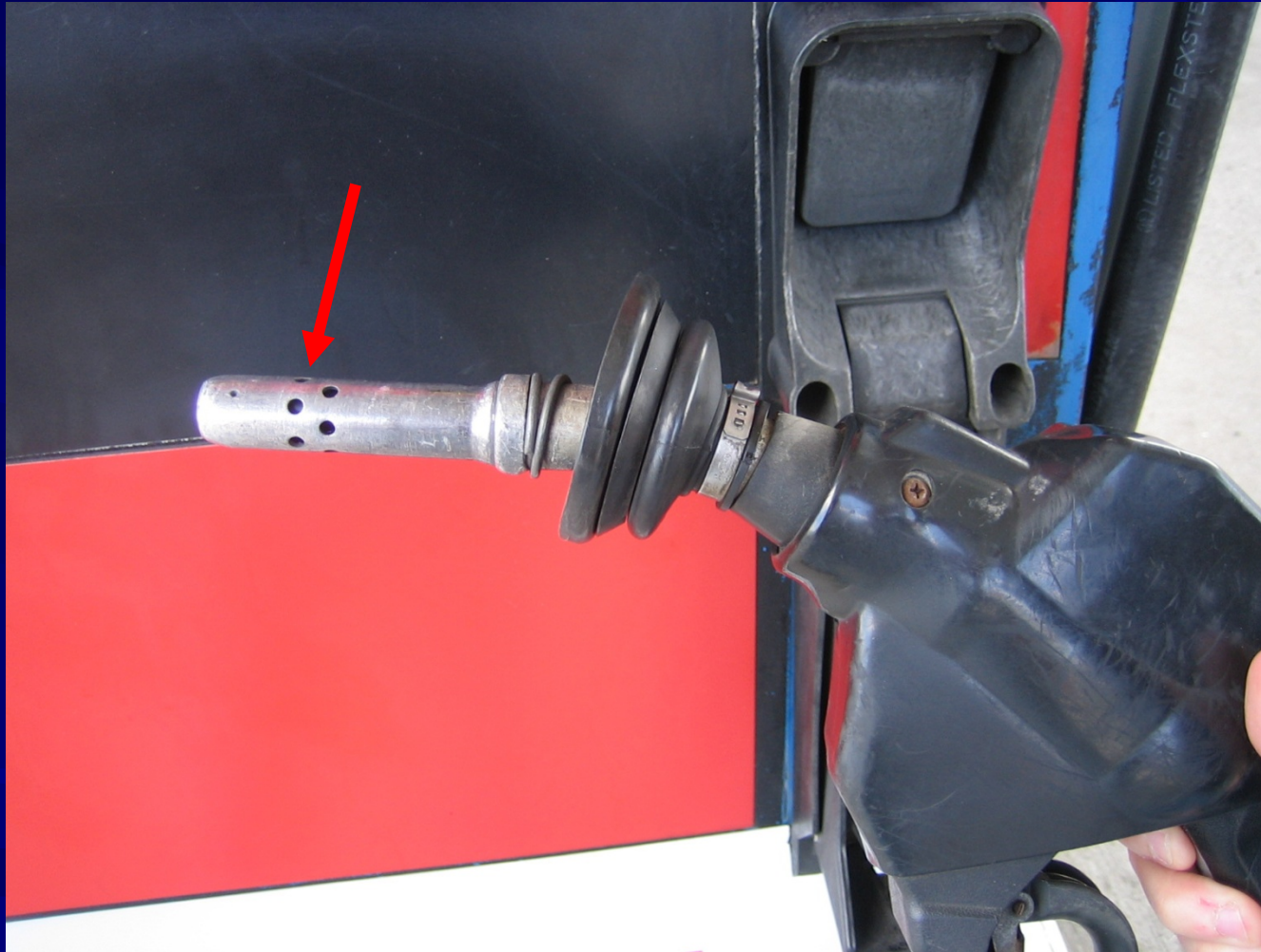

Another good close-up, and personal view of Mr. Vac Assist nozzle. These nozzles will either have an internal check valve, or none at all. Some Vac Assist systems have the check valve in the dispenser. Needless to say, mixing and matching equipment could get dicey with this kind of system.

Vacuum Assist

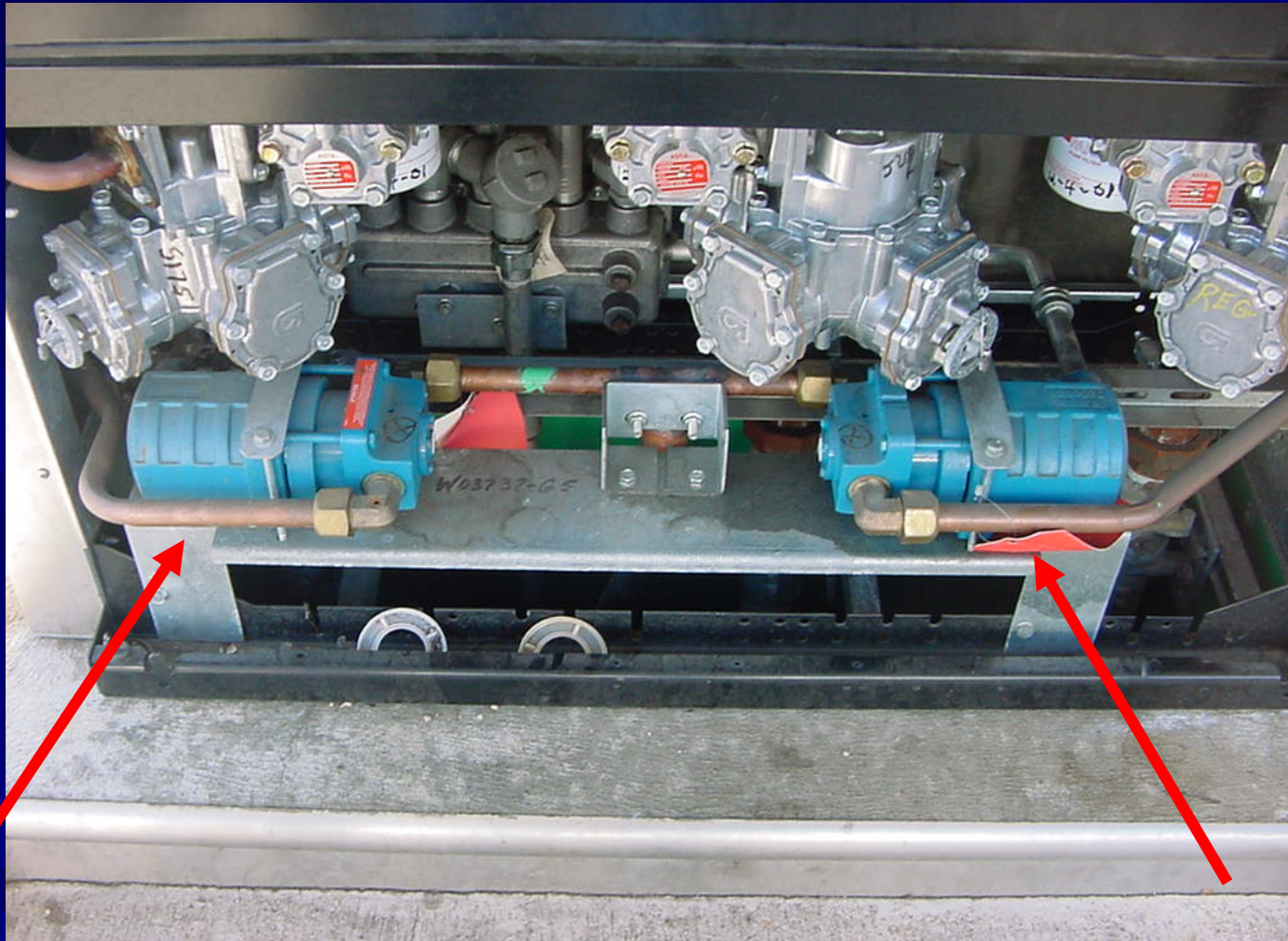

The red arrows are pointing to two Healy Vac-Pumps located in the dispenser at a Vac-Assist station. It is much more common nowadays for these to be in each dispenser rather than the tank field.

Vacuum Assist



Another example of a Healy Jet pump, this one is in the tank field. You might find just one of these per station, or possibly one per tank at a high volume station. This is considered an “antique”.

The ORVR Problem

(That's Onboard Refueling Vapor Recovery for you sports fans)

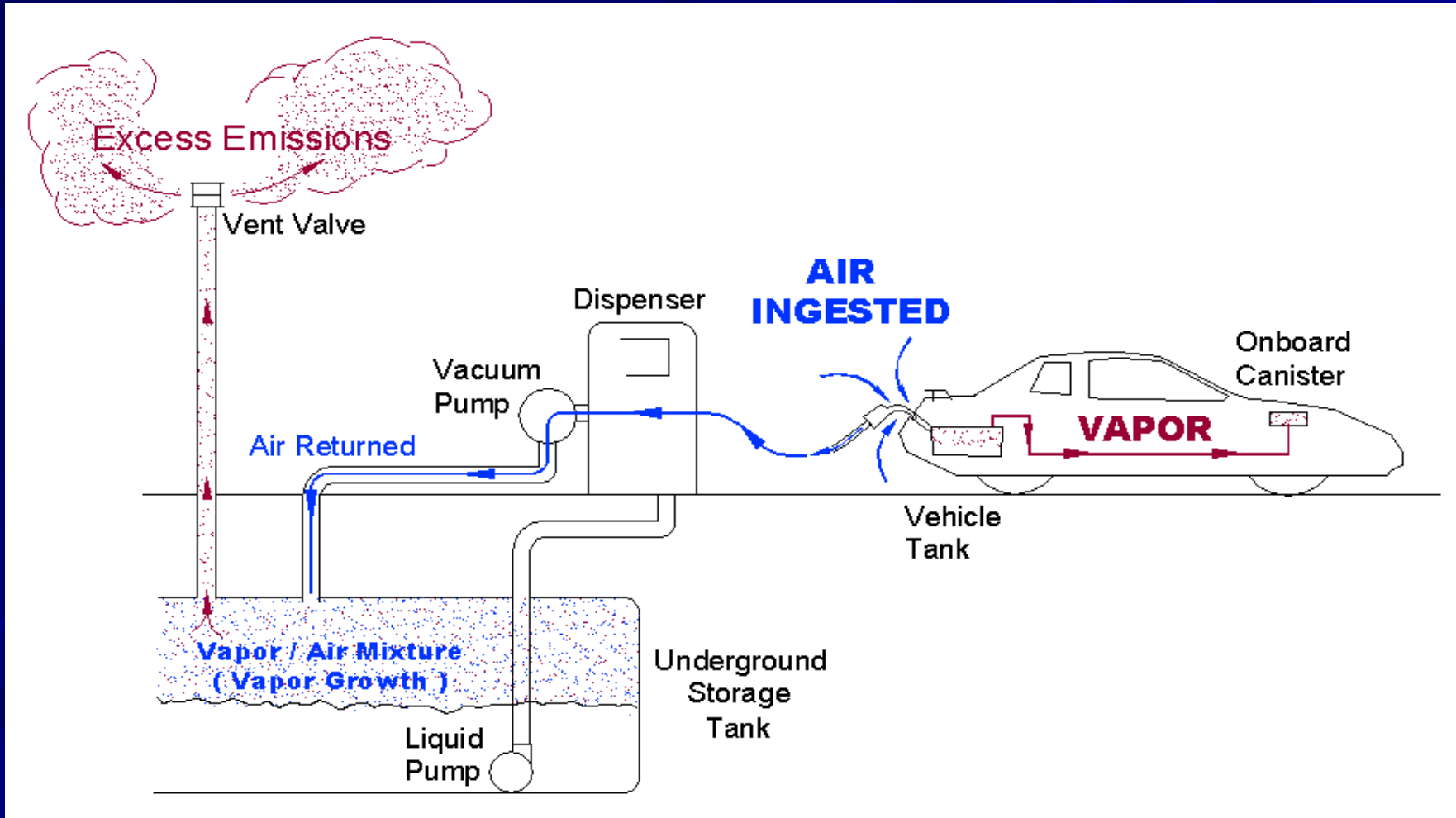



One Solution...

ORVR COMPATIBLE HEALY NOZZLE



With it being well-documented that Vacuum Assist systems are causing an over-pressurization problem at many stations due to the presence of ORVR canisters in newer-modeled cars, some manufacturers have developed nozzles that can detect ORVR and reduce air ingestion.

ORVR Nozzle

Up close and personal with the Healy 800/900 series



No, this is not “your daddy’s” vac-assist nozzle. Notice the ORVR diaphragm, and that the vacuum holes do NOT exist on this nozzle. Instead, the vacuum comes from the small boot that is much shorter than a balance nozzle. The only hole at the spout is the automatic shut-off. The reason this boot is much smaller than a balance nozzle is because there can not be a tight seal with the vehicle tank. If there was, the tank could collapse.

A \$\$\$ Alternative



This is a system developed and sold by ARID Technologies called the “Permeator”. One or two other companies have products that perform a similar function. It connects to the vent pipe and regulates in-tank pressure by using a membrane system that separates vapor from air, and returning only vapor to the tank. This device is extremely costly to purchase and install, so it only exists at major retailers such as Wawa. The company boasts that this product will eventually save money for the station, since it reduces lost product to vaporization.

Testing Requirements

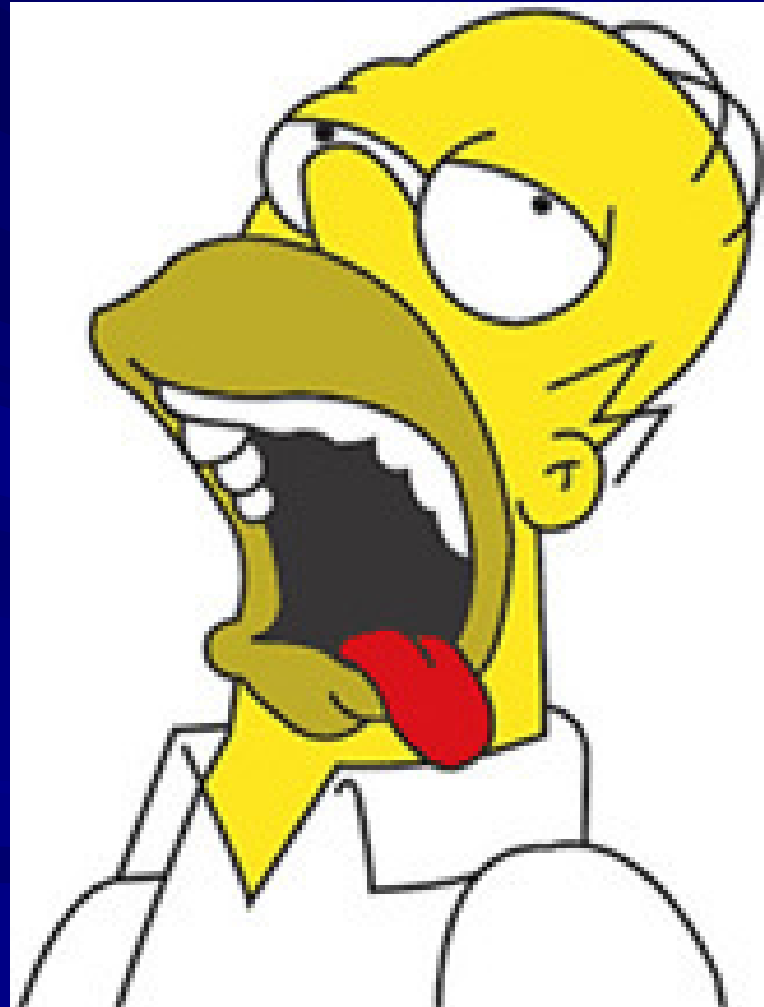

Testing Requirements

Static Pressure Performance Test

- CARB test method TP-201.3
- Formerly known as a “Pressure Drop” test
- Some contractors still call it “Pressure Decay”
- Must be performed within 90 days of installation and every 12 months thereafter
- Results must be made available to inspector
- Applies to every facility required to have a vapor control system
- Test must be performed with caps OFF the fill

* All tests required only for facilities that require Stage II Vapor recovery

Testing Requirements (cont)

Pressure Vacuum Valve Test

- CARB test method TP-201.1E
- Must be conducted within 90 days of installation and every 12 months thereafter
- Results must be made available to inspector
- Applies to every facility required to have a vapor control system
- There are two parts to this test: cracking pressure and flow rate. The valve must be removed from the vent to test the flow rate.

Testing Requirements (cont)

Dynamic Backpressure Test

- CARB test method TP-201.4
- Must be conducted within 90 days of installation and every 36 months thereafter
- Results must be made available to inspector
- Applies to every facility required to have a vapor control system
- Formerly known as a "Blockage Test"

Testing Requirements (cont)

Air to Liquid Volume Ratio Test

- CARB test method TP-201.5
- Must be conducted within 90 days of installation and every 12 months thereafter
- Results must be made available to inspector
- Applies to Vacuum Assist facilities only
- Ratio is .9-1.1/1
- A vast majority of stations will fail the first test, then need a recalibration before passing as a result of ORVR incompatibility

GP-004A Additions

- Pressure/Vacuum Valve CARB Test Procedure updated to TP-201.1E
- Allows for P/V valves to be replaced every 2 years in lieu of the test
- Federal MACT standards included (most stringent requirement must be complied with, ex: drop tube length)
- Requires post-delivery visual inspection of P/V valve (is it still there and in one piece?)

GP-004A Additions (cont.)

- Requires breakaways
- Combines multiple existing GPs
- Allows for greater annual throughput (with an additional control, permeator et al)
- Improved data collection
- E85

Penalty Schedule

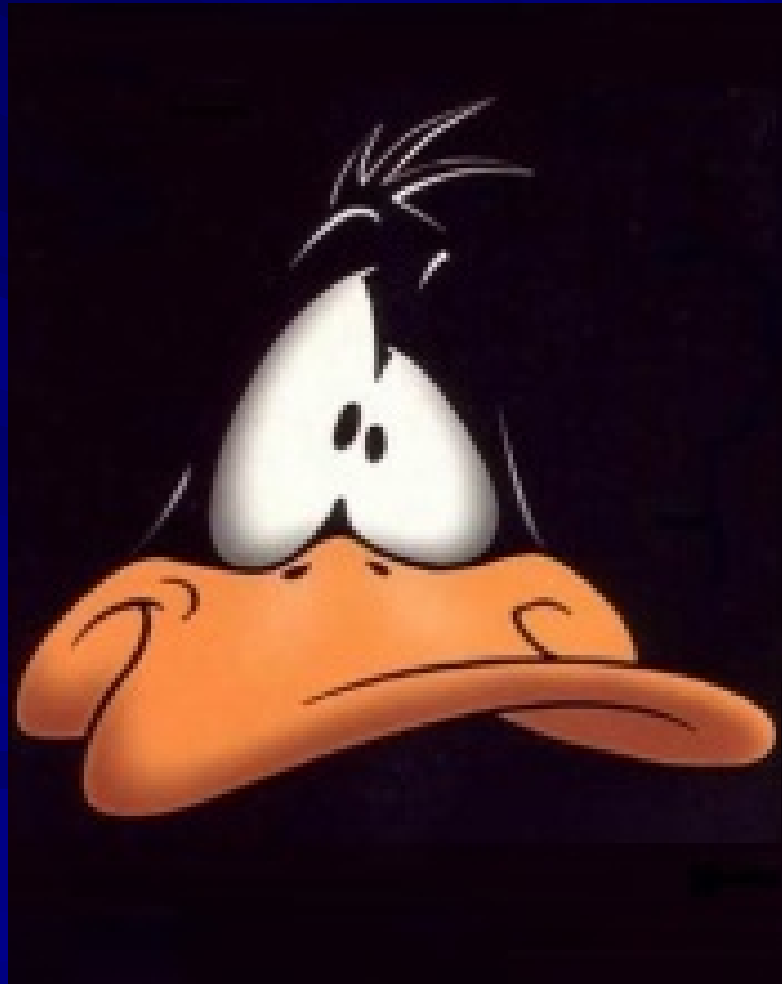

VRS Penalties

First, Second, Third, and Subsequent Offenses

- Permitting penalties are the same as GEN
- 16.3(d) – Stage I not present or not operating

\$600	\$1,200	\$3,000	\$9,000
-------	---------	---------	---------

- 16.3(e) – Stage II not present or not operating

\$600	\$1,200	\$3,000	\$9,000
-------	---------	---------	---------

- 16.3(c) – No submerged Fill

\$600	\$1,200	\$3,000	\$9,000
-------	---------	---------	---------

- 16.3(i)1 – Failure to conduct required testing <1 year = Grace Period

\$500	\$1,000	\$2,500	\$7,500
-------	---------	---------	---------

Contacts

- Northern Field Office – 973-656-4099

(Union, Somerset, Essex, Hudson, Bergen, Passaic, Hunterdon, Warren, Sussex, Morris)

- Trenton – 609-943-3019

(Mercer, Middlesex, Monmouth, Ocean)

- Southern Field Office – 856-614-3655

(Burlington, Camden, Gloucester, Salem, Cumberland, Cape May, Atlantic)