

**DEMONSTRATION TESTING AND
FULL-SCALE OPERATION OF THE
BIOGENESISSM SEDIMENT DECONTAMINATION PROCESS**



Final Report

December 17, 2009

KEASBEY, NEW JERSEY

BioGenesis Washing BGW, LLC

7420 Alban Station Blvd. • Suite B-208 • Springfield, Virginia 22150 USA • TEL (703) 913-9700 • FAX (703) 913-9704

**DEMONSTRATION TESTING AND
FULL-SCALE OPERATION OF THE
BIOGENESISSM SEDIMENT DECONTAMINATION PROCESS**

Keasbey, New Jersey

December 17, 2009

Prepared by:

**BioGenesis Washing BGW, LLC
Springfield, VA**

**MWH Americas, Inc.
Salt Lake City, Utah**

Abstract

BioGenesis Washing BGW, LLC performed a full-scale demonstration of the BioGenesisSM Sediment Decontamination Technology under contract to the New Jersey Department of Transportation, Office of Maritime Resources. The US Environmental Protection Agency provided services in support of the demonstration project.

The BioGenesisSM Sediment Decontamination Technology is a patented low temperature decontamination process for fine-grained sediment that uses impact forces and proprietary washing chemicals to remove organic and inorganic contamination. The resulting decontaminated fine-grained material can be used to create a high-end topsoil or other construction products.

Approximately 15,000 cubic yards of dredged material from three sources in the New York/New Jersey Harbor (Raritan River, Arthur Kill, and the Lower Passaic River) were decontaminated and beneficially used during the demonstration project. The full-scale BioGenesis demonstration facility was operated at a processing rate of 250,000 cubic yards per year and included all components of a commercial-scale facility including sediment offloading, upfront storage, decontamination, and wastewater treatment.

Analytical results for samples collected of the manufactured topsoil produced from the decontaminated sediment showed the material passes the current New Jersey Residential Soil Cleanup Standards (NJDEP, 2008). Full-scale cost projections at \$51.00 to \$59.00 per cubic yard show that the technology can be competitive with the current costs for management of harbor navigational dredged material that is not suitable for ocean placement.

The BioGenesisSM Sediment Decontamination Technology is ready for commercial application to process contaminated navigational dredged material. It can reliably decontaminate navigational dredged material to produce a manufactured soil for beneficial use.

TABLE OF CONTENTS

ABSTRACT	iii
TABLE OF CONTENTS	v
TABLE OF TABLES.....	ix
TABLE OF FIGURES.....	x
LIST OF ACRONYMS.....	xii
EXECUTIVE SUMMARY	ES-1
ES.1 Background	ES-1
ES.2 Technology Description	ES-3
ES.3 Sediment Sources	ES-4
ES.4 Facility Operations.....	ES-5
ES.5 Analytical Results	ES-7
ES.6 Bench-Scale Testing of Lower Passaic River Sediment.....	ES-11
ES.7 Manufactured Soil Demonstration	ES-14
ES.8 Commercial-Scale System Recommendations.....	ES-15
ES.9 Projected Commercial-Scale Costs.....	ES-16
ES.10 Conclusions.....	ES-17
1 INTRODUCTION.....	1-1
1.1 Project Overview	1-1
1.2 Background	1-2
1.3 Project Objectives.....	1-4
1.4 Project Team	1-4
1.5 Organization of the Full-Scale Demonstration Project Report	1-6
2 BIOGENESIS SM SEDIMENT DECONTAMINATION TECHNOLOGY.....	2-1
2.1 Technology Description	2-1
2.2 Additional Technology Demonstration Projects	2-5
3 DEMONSTRATION PROJECT ACTIVITIES	3-1
3.1 Project Site.....	3-1
3.2 Permitting and Approvals	3-1

TABLE OF CONTENTS (continued)

3.3	Facility Design	3-4
3.3.1	Dredged Material Offloading and Upfront Storage.....	3-4
3.3.2	Process Equipment Components	3-6
3.3.3	Processed Dredged Material Storage Area.....	3-19
3.4	Facility Construction	3-19
3.5	Sediment Sources	3-20
3.6	Sediment Volumes	3-23
3.7	Sample Collection	3-25
3.8	Data Validation	3-28
3.9	Air Monitoring	3-31
3.10	Demobilization	3-31
3.10.1	Process Equipment and Processing Facility	3-31
3.10.2	Processed Dredged Material	3-31
3.10.3	Untreated Dredged Material.....	3-32
3.11	Manufactured Soil Demonstration	3-33
3.12	Demonstration Project Costs	3-33
4	DISCUSSION OF RESULTS	4-1
4.1	Production and Processing Rates	4-1
4.2	Equipment Performance	4-3
4.2.1	Barge Offloading and Screening.....	4-5
4.2.2	Upfront Storage Facility	4-7
4.2.3	Dredged Material Transfer.....	4-9
4.2.4	Secondary Screening.....	4-9
4.2.5	Mix Tanks.....	4-10
4.2.6	Chemical Addition.....	4-10
4.2.7	BioGenesis™ Preprocessor.....	4-11
4.2.8	BioGenesis™ Collision Chamber.....	4-11
4.2.9	BioGenesis™ Cavitation/Oxidation Unit.....	4-12
4.2.10	Hydrocyclone and Wet Screens	4-12
4.2.11	Centrifuge 1	4-13

TABLE OF CONTENTS (continued)

4.2.12	Centrifuge 2	4-14
4.2.13	Clarifier	4-14
4.2.14	Sand Filters	4-15
4.2.15	Carbon Filters	4-15
4.2.16	Wastewater Lift Station.....	4-16
4.2.17	Piping.....	4-16
4.2.18	Pumps.....	4-17
4.2.19	Power Supply	4-18
4.2.20	Processed Dredged Material Transfer and Storage.....	4-18
4.3	Analytical Results	4-19
4.3.1	Raritan River Sediment	4-19
4.3.2	Arthur Kill Sediment.....	4-26
4.3.3	Lower Passaic River Sediment	4-34
4.3.4	Wastewater Treatment.....	4-41
3.3.5	Bench-Scale Testing of Lower Passaic River Sediment	4-43
3.3.6	Manufactured Soil Demonstration.....	4-46
4.4	Fate of Contaminants.....	4-52
5	COMMERCIAL-SCALE SYSTEM RECOMMENDATIONS.....	5-1
5.1	Design Improvements.....	5-1
5.2	Site Selection	5-2
5.3	Projected Commercial-Scale Costs.....	5-3
6	CONCLUSIONS AND RECOMMENDATIONS	6-1
6.1	Conclusions.....	6-1
6.1.1	Process Verification to Meet New Jersey Soil Remediation Standards.....	6-1
6.1.2	Verification that Costs are Consistent with Current Prices for the Management of Contaminated Navigation Dredged Material	6-2
6.2	Recommendations	6-4
6.2.1	Technology Assessment.....	6-4
6.2.2	Process Optimizations.....	6-4
7	REFERENCES	7-1

TABLE OF CONTENTS (continued)

APPENDIX A PHOTOS

APPENDIX B ANALYTICAL RESULTS SUMMARY TABLES

APPENDIX C DATA VALIDATION REPORT

**APPENDIX D MIDDLESEX COUNTY UTILITIES AUTHORITY, MONTHLY
MONITORING REPORTS**

**APPENDIX E RESULTS OF BENCH-SCALE TESTING OF THE BIOGENESISSM
SEDIMENT DECONTAMINATION TECHNOLOGY FOR
POLYAROMATIC HYDROCARBONS IN SEDIMENT FROM THE
LOWER PASSAIC RIVER**

TABLE OF TABLES

Table 3-1	Typical NY/NJ Harbor Sediment Characteristics and New Jersey Residential Soil Standards.....	3-5
Table 3-2	Average Chemical Concentrations and Physical Characteristics of the Untreated Sediment.....	3-24
Table 3-3	Summary of Sampling Program and Data Quality Objectives	3-27
Table 3-4	Sampling Location Identification Descriptions.....	3-30
Table 3-5	Full-Scale Demonstration Project Cost Summary.....	3-34
Table 4-1	Amount of Oversized Debris Removed.....	4-5
Table 4-2	Summary of Barge Offloading Activities	4-6
Table 4-3	Average Chemical Concentrations in Samples Collected During Optimum Operating Conditions without Chelant – Raritan River Sediment.....	4-20
Table 4-4	Average Chemical Concentrations in Samples Collected During Optimum Operating Conditions with Chelant – Raritan River Sediment.....	4-23
Table 4-5	Average Chemical Concentrations in Samples Collected During Optimum Operating Conditions – Arthur Kill Sediment.....	4-27
Table 4-6	Average Chemical Concentrations in Samples Collected During Optimum Operating Conditions – Lower Passaic River Sediment	4-35
Table 4-7	Summary of Treated Wastewater Sampling Results	4-42
Table 4-8	Analytical Results for Manufactured Soil Additives.....	4-48
Table 4-9	Manufactured Soil Testing Results	4-49
Table 4-10	Manufactured Soil Analytical Results	4-50
Table 4-11	Summary of Mass Balance Results from the 1999 Pilot Demonstration Project	4-55
Table 5-1	Estimated Capital and Operating Costs for a Commercial-Scale BioGenesis Sediment Decontamination Facility	5-4
Table 6-1	Summary of USACE Dredging Project Costs	6-3

TABLE OF FIGURES

Figure ES-1	General Overview of the BioGenesis SM Sediment Decontamination Technology.....	ES-3
Figure ES-2	Dredged Material Processing	ES-5
Figure ES-3	BioGenesis Facility Uptime.....	ES-6
Figure ES-4	Analytical Results for Metals – Lower Passaic River Sediment.....	ES-8
Figure ES-5	Analytical Results for PCBs and Dioxins – Lower Passaic River Sediment.....	ES-9
Figure ES-6	Analytical Results for PAHs – Lower Passaic River Sediment	ES-10
Figure ES-7	Analytical Results for Metals – Manufactured Soil	ES-14
Figure ES-8	Analytical Results for PAHs – Manufactured Soil.....	ES-15
Figure ES-9	Analytical Results for PCBs and Dioxins – Manufactured Soil.....	ES-15
Figure 1-1	Project Organization.....	1-5
Figure 2-1	General Overview of the BioGenesis SM Sediment Decontamination Process	2-2
Figure 3-1	Site Location Map.....	3-2
Figure 3-2	Block Flow Diagram	3-7
Figure 3-3	Process Flow Diagram.....	3-9
Figure 3-4	BioGenesis Demonstration Site Layout.....	3-21
Figure 3-5	Total Dredged Material Stored in the Upfront Storage Facility	3-26
Figure 3-6	Sample Locations	3-29
Figure 4-1	Dredged Material Processing	4-2
Figure 4-2	BioGenesis Facility Uptime.....	4-4
Figure 4-3	Total Dredged Material Stored in Each Hold of the Upfront Storage Facility	4-8
Figure 4-4	Analytical Results for Metals without Chelant – Raritan River Sediment.....	4-21
Figure 4-5	Analytical Results for Metals with Chelant – Raritan River Sediment.....	4-22
Figure 4-6	Analytical Results for PAHs – Raritan River Sediment.....	4-24

TABLE OF FIGURES (continued)

Figure 4-7	Analytical Results for PCBs and Dioxins – Raritan River Sediment...	4-25
Figure 4-8	Analytical Results for Arsenic and Lead – Arthur Kill Sediment	4-29
Figure 4-9	Analytical Results for Mercury – Arthur Kill Sediment.....	4-30
Figure 4-10	Analytical Results for Benzo(a)pyrene and Benzo(a)anthracene – Arthur Kill Sediment.....	4-31
Figure 4-11	Analytical Results for Dibenz(a,h)anthracene – Arthur Kill Sediment.....	4-32
Figure 4-12	Analytical Results for PCBs and Dioxins – Arthur Kill Sediment.....	4-33
Figure 4-13	Analytical Results for Arsenic and Lead – Lower Passaic River Sediment.....	4-37
Figure 4-14	Analytical Results for Mercury – Lower Passaic River Sediment	4-38
Figure 4-15	Analytical Results for Benzo(a)pyrene and Benzo(a)anthracene – Lower Passaic River Sediment	4-39
Figure 4-16	Analytical Results for Dibenz(a,h)anthracene – Lower Passaic River Sediment	4-40
Figure 4-17	Analytical Results for Total PCBs – Lower Passaic River Sediment...	4-40
Figure 4-18	Analytical Results for Dioxins – Lower Passaic River Sediment.....	4-41
Figure 4-19	Analytical Results for Metals – Manufactured Soil	4-51
Figure 4-20	Analytical Results for PAHs – Manufactured Soil.....	4-51
Figure 4-21	Analytical Results for PCBs and Dioxins – Manufactured Soil	4-52

LIST OF ACRONYMS

AUD	Acceptable Use Determination
Bayshore	Bayshore Recycling Corp.
BioGenesis	BioGenesis Washing BGW, LLC
BNL	Brookhaven National Laboratory
BOD	biological oxygen demand
CEDTI	Clean Earth Dredging Technologies, Inc.
COD	chemical oxygen demand
cy	cubic yard or cubic yards
DDD	dichlorodiphenyldichloroethane
DDE	dichlorodiphenyldichloroethylene
dioxins	polychlorinated dibenzo-dioxins
DOE	United States Department of Energy
EPA	Environmental Protection Agency
furans	polychlorinated dibenzo-furans
HARS	Historic Area Remediation Site
HASP	Health and Safety Plan
HDPE	high-density polyethylene
K_{oc}	organic carbon partitioning coefficient
kW	kilowatt
MCUA	Middlesex County Utility Authority
mgd	million gallons per day
mg/kg	milligrams per kilogram (parts per million)
mm	millimeters
MWH	Montgomery Watson Harza
MSU	Montclair State University
NJDEP	New Jersey Department of Environmental Protection
NJDOT	New Jersey Department of Transportation

LIST OF ACRONYMS (continued)

NJRDCSRS	New Jersey Residential Direct Contact Soil Remediation Standards
NJRSCS	New Jersey Residential Soil Cleanup Standards
NPDES	National Pollutant Discharge Elimination System
NY/NJ	New York/New Jersey
OMR	Office of Maritime Resources
PAH	polyaromatic hydrocarbon
PCB	polychlorinated biphenyl
PFD	process flow diagram
pg/g	picograms per gram (parts per trillion)
POTW	Publicly Owned Treatment Works
psi	pounds per square inch
PVC	polyvinyl chloride
QAPP	Quality Assurance Project Plan
Rutgers	Rutgers, The State University of New Jersey, Agricultural Experiment Station
SITE	Superfund Innovative Technology Evaluation
SVOC	semi-volatile organic compound
TCDD	tetrachlorodibenzo-p-dioxin
TCDF	tetrachlorodibenzofuran
TCLP	Toxicity Characteristic Leaching Procedure
TEFs	toxicity equivalency factors
TEV	toxicity equivalency value
TOC	total organic carbon
TPH	total petroleum hydrocarbons
µg/kg	micrograms per kilogram (parts per billion)
USACE	United States Army Corps of Engineers
USEPA	United States Environmental Protection Agency

LIST OF ACRONYMS (continued)

VOC	volatile organic compound
WDP	Waterfront Development Permit
WHO	World Health Organization
WRDA	Water Resources Development Act

EXECUTIVE SUMMARY

Presented in this report are the results of a Full-Scale Demonstration of the BioGenesisSM Sediment Decontamination Technology conducted on dredged material from the New York/New Jersey (NY/NJ) Harbor. The project was performed by BioGenesis Washing BGW, LLC (BioGenesis), under contract to the New Jersey Department of Transportation (NJDOT), Office of Maritime Resources (OMR).

ES.1 Background

Dredging of the NY/NJ Harbor is necessary to maintain the water passages to accommodate shipping. These water channels, which have a natural depth averaging 19 feet, require sediment removal to depths of 40 to 55 feet to allow for safe navigation of vessels through the harbor. Approximately 2 to 4 million cubic yards (cy) of sediment is dredged annually, from the NY/NJ Harbor. Based on the concentrations of heavy metals, organic compounds, and other chemical constituents present in these sediments, the U.S. Army Corps of Engineers (USACE) estimates that approximately 1.1 million cy of the material projected to be dredged annually through year 2040 will require upland disposal and/or treatment (USACE, 2008).

Under the Water Resources Development Acts of 1992 (Section 405C) and 1996 (Section 226), Congress directed the U.S. Environmental Protection Agency (EPA) – Region 2 and the USACE – New York District to develop a Sediment Decontamination Demonstration Program (WRDA Decontamination Program) with the goal of demonstrating one or more facilities with the capacity to commercially decontaminate up to 500,000 cy of contaminated dredged material annually from the NY/NJ Harbor. The WRDA Decontamination Program has progressed through bench-scale and pilot-scale demonstrations of various technologies and has resulted in a reduction of the number of participants through several factors including technical performance, demonstration costs, private-public cost sharing, beneficial

use of treated material, and evaluations of the business potential for commercial-scale decontamination. The BioGenesisSM Sediment Decontamination Technology was selected to proceed from pilot-scale to full-scale demonstration by the WRDA Decontamination Program.

The NJDOT also has a mission of promoting the development of commercially viable beneficial use technologies including sediment decontamination technologies. Through the New Jersey Sediment Decontamination Technology Demonstration Program, the NJDOT/OMR is continuing the work of the WRDA Decontamination Program and fostering the startup of businesses that can provide cost-effective sediment decontamination on a commercial scale. The BioGenesisSM Sediment Decontamination Technology was selected by the NJDOT/OMR as one of the technologies to be demonstrated on a commercial scale. Since both the EPA and OMR are coordinating their efforts for the demonstration of sediment decontamination technologies, this project was authorized and funded under both entities.

The main objectives of the BioGenesisSM Sediment Decontamination Technology demonstration project were:

- to verify that the BioGenesis process is capable of consistently treating contaminated sediment such that it meets the New Jersey Residential Direct Contact Soil Remediation Standards (NJRDCSRS) and thus generate a treated sediment product that can be used for unrestricted beneficial uses,
- to verify that the BioGenesisSM Sediment Decontamination Technology is capable of performing reliably at a cost consistent with the current prices for management of contaminated navigational dredged material, and
- to estimate the commercial-scale sediment treatment costs for the BioGenesis process at the throughput rate of 40 cy per hour (250,000 cy per year).

ES.2 Technology Description

The BioGenesisSM Sediment Decontamination Technology is a patented ambient temperature decontamination process for coarse- and fine-grained sediment, which uses impact forces and proprietary chemicals to remove organic and inorganic contamination. The resulting decontaminated sediment is used to produce high-end topsoil or other construction grade products. Presented in Figure ES-1 is an overview of the general BioGenesisSM Sediment Decontamination Technology.

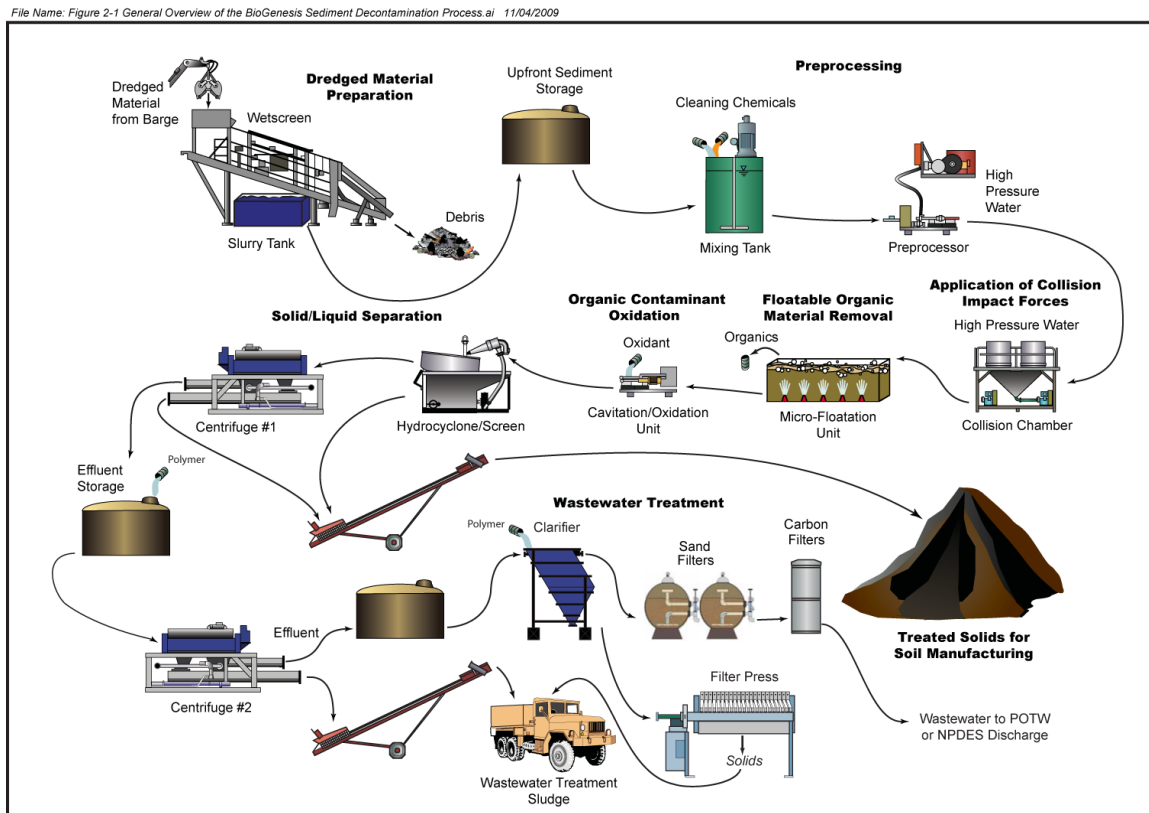

Figure ES-1 General Overview of the BioGenesisSM Sediment Decontamination Technology

The BioGenesisSM Sediment Decontamination Technology, consists of eight main processing steps including:

- **Dredged Material Preparation** – offloading, screening, and temporary storage
- **Preprocessing** – addition of proprietary washing chemicals and disaggregation of the sediment particles from each other and from the loosely-associated naturally occurring organic material (called biomass)

- **Application of Collision Impact Forces** – stripping the biofilm layer and adsorbed contaminants from the solid sediment particles
- **Floatable Organic Material Removal** – removal of light organic material using micro-floatation
- **Organic Contaminant Oxidation** – destruction of organic contaminants using enhanced oxidation (Cavitation/Oxidation)
- **Solid/Liquid Separation** – recovery of the cleaned sediment particles
- **Wastewater Treatment** – pre-treatment of the resulting wastewater and discharge to the local publicly owned treatment works
- **Soil Manufacturing** – blending of the decontaminated sediment with other raw materials to produce a high-end topsoil

ES.3 Sediment Sources

Sediment for the demonstration project was obtained from three sources, the Raritan River, the Lower Passaic River, and the Arthur Kill. In general, the concentrations of organic contaminants were much higher in the Arthur Kill and Lower Passaic River sediment than in the Raritan River sediment, with the levels in the Lower Passaic River sediment consistently higher than those in the Arthur Kill sediment. The concentrations of most metals in the untreated sediment followed similar trends with a few exceptions; Arsenic concentrations were much higher in the Raritan River sediment; Mercury concentrations were the highest in the Arthur Kill sediment; and Nickel concentrations were consistent through all three sediment sources.

The grain size distribution in the Arthur Kill and Lower Passaic River sediment was approximately 26 to 29% sand, 47 to 53% silt, and 18 to 21% clay. The grain size distribution in the Raritan River sediment had less sand (15%) and more clay (30%) on average as compared to the other two source areas.

The average total organic carbon (TOC) concentration in the untreated sediment was the highest in the Lower Passaic River sediment at 61,460 mg/kg, followed by

44,230 mg/kg in the sediment from the Arthur Kill and 24,796 mg/kg in the Raritan River sediment.

ES.4 Facility Operations

During the BioGenesisSM Sediment Decontamination Technology demonstration project, the dredged material that was processed in the facility was changed frequently (daily and sometimes several times a day) to allow time for analytical testing of samples collected under different operating conditions from different sources. Presented in Figure ES-2 is a graph of the quantities of dredged material from each of the three sources processed during the BioGenesis demonstration project. A total of 14,724 cy of dredged material was processed through the BioGenesis facility during the demonstration project, 3,539 cy from the Raritan

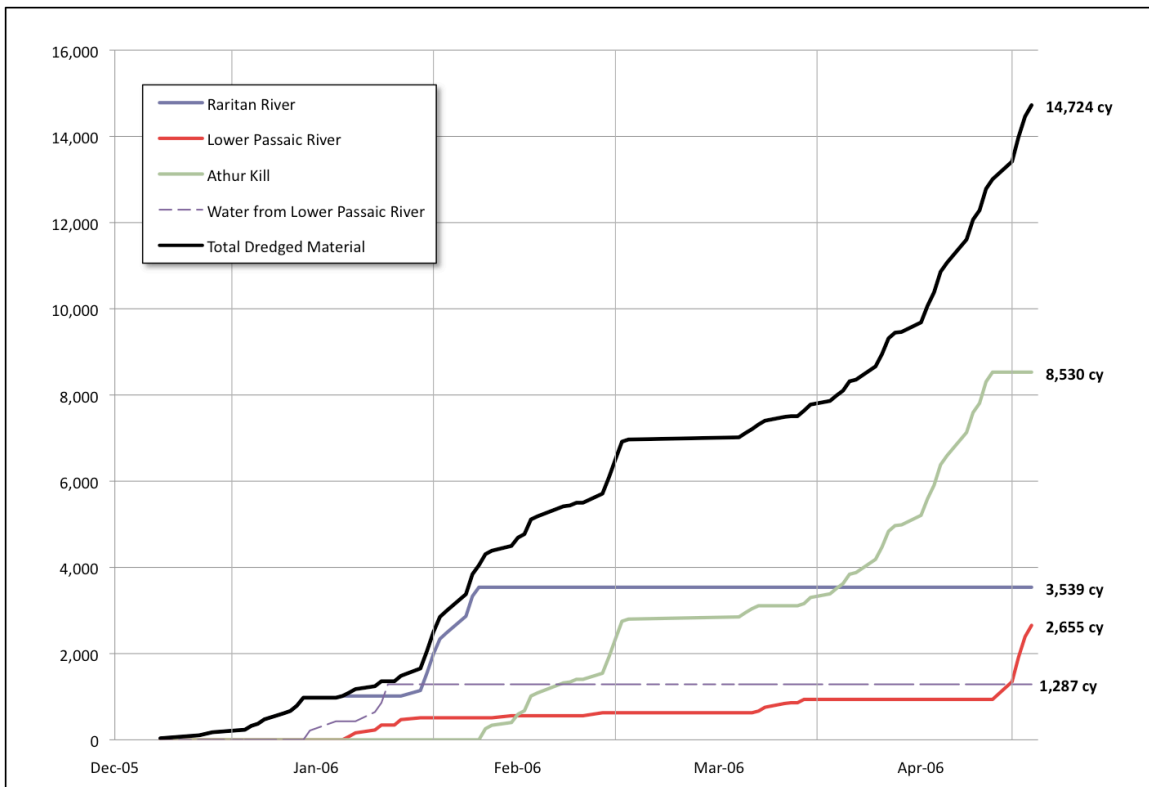

Figure ES-2 Dredged Material Processing

River, 2,655 cy from the Lower Passaic River, and 8,530 cy from the Arthur Kill. In addition, a total of 1,287 cy (259,960 gallons) of water was removed from the top of the cargo holds with dredged material from the Lower Passaic River and processed

through the wastewater treatment portion of the BioGenesis sediment decontamination facility.

As stated previously, the BioGenesis sediment decontamination facility was designed to achieve an average plant uptime (processing time) of 80%. This was evaluated during the demonstration project to provide design information for a permanent facility. At times during the project, the facility operated 24 hours per day, and involved two shifts. The plant uptime was evaluated by shift and for the entire day to be able to compare the performance of the two shifts. As illustrated in Figure ES-3 the daily facility uptime was around 40% during the beginning of the project and reached 80 to 90% at the end of the demonstration project. The day shift, somewhat consistently outperformed the night shift. Factors affecting the

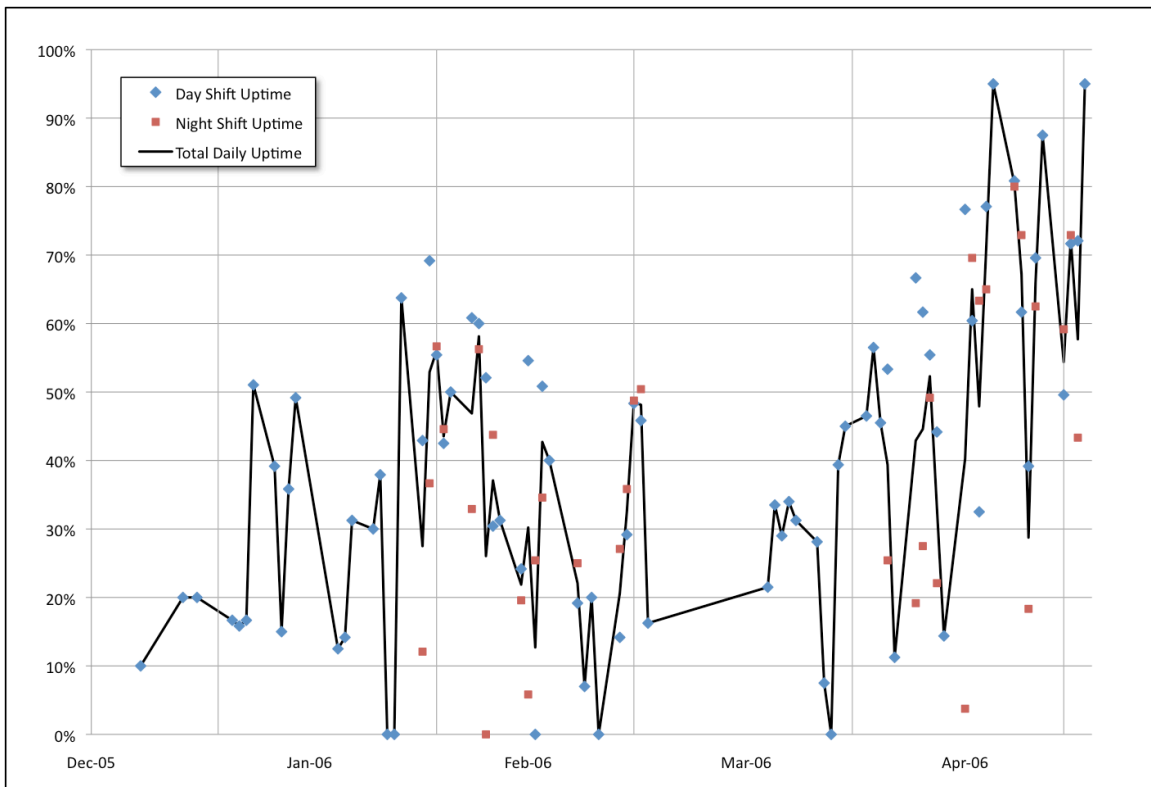

Figure ES-3 BioGenesis Facility Uptime

processing time or facility uptime included initial startup problems, the use of rental equipment, the lack of inline spare equipment, and the location of the Treated

Sediment Storage Facility with respect to the processing facility. None of these factors would impact a properly designed commercial-scale permanent facility.

ES.5 Analytical Results

Throughout the demonstration project, dredged material from each of the three sources was processed using multiple operating conditions to evaluate the performance of the BioGenesisSM Sediment Decontamination Process. Hundreds of samples of the untreated sediment, treated sediment, and manufactured soil product were collected during operations in accordance with the sampling protocols established in the project Quality Assurance Project Plan (QAPP). The analytical results were evaluated against the QAPP data quality objectives and the data was verified to be of sufficient quality to make informed decisions about the efficacy of the BioGenesisSM Sediment Decontamination Process demonstrated in Keasbey, New Jersey.

A discussion of the analytical results for samples collected during the processing of all three sediment sources is included in the report. Since the sediment from the Lower Passaic River had the highest concentrations of organic contaminants, a discussion of the analytical results for the processing of the Lower Passaic River sediment follows.

During the initial operations on the sediment from the Lower Passaic River, significant problems were encountered with the sediment plugging in the piping and processing equipment. This was due to an unusually high amount of trash and debris in the Lower Passaic River sediment. The debris included household trash such as plastic bags, straws, and food wrappers as well as a significant amount of organic detritus such as twigs and leaves. The debris/detritus would cause blockages in the piping and process equipment and did not allow for consistent uninterrupted operations. A secondary screening step was installed on February 24, 2006 to remove this debris and detritus and operations dramatically improved.

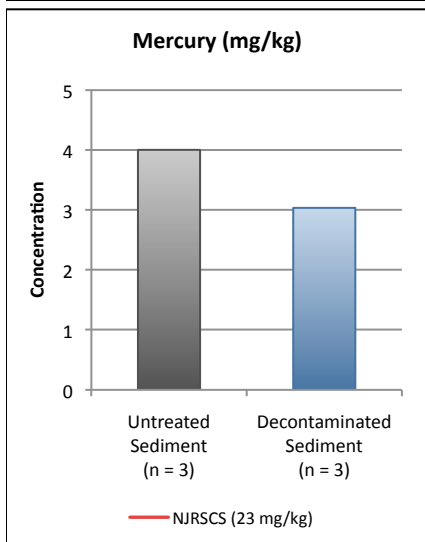
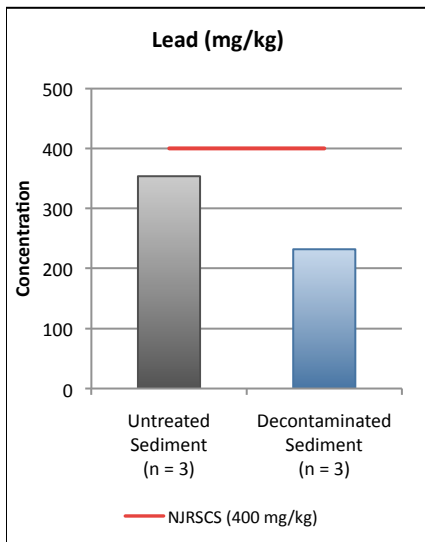
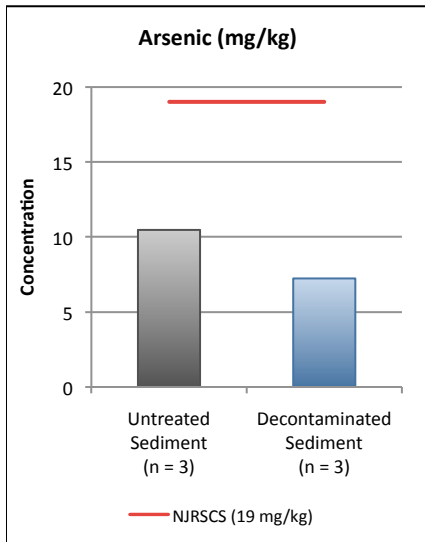

Figure ES-4 Analytical Results for Metals – Lower Passaic River Sediment

A total of 3,655 cy of dredged material from the Lower Passaic River was processed through the BioGenesis sediment decontamination facility on 18 operational days between January 19 and May 4, 2006. After the secondary screen was installed, several days of operation were conducted on sediment from the Lower Passaic River at varying operating conditions to determine the optimum operating parameters. This culminated in the continuous operations, at the same operating conditions, on the Lower Passaic River sediment from May 2 through May 4, 2006.

Presented in Figure ES-4 are graphical representations of the analytical results for select metals (arsenic, lead, and mercury) of samples collected on optimum operating days for the sediment from the Lower Passaic River. The concentrations of metals in the untreated sediment were not elevated above the NJRDSCRS. The concentrations of metals in the decontaminated sediment were reduced through the BioGenesisSM Sediment Decontamination Process.

Presented in Figure ES-5 are graphical representations of the analytical results for total polychlorinated biphenyls (PCBs), 2,3,7,8-tetrachlorodibenzo-p-dioxin (2,3,7,8-TCDD), and dioxin toxicity equivalency values (TEVs) for samples collected on the optimum operating days for the sediment from the Lower Passaic River. There is a reduction in PCB concentrations observed through the BioGenesisSM Sediment Decontamination Process (untreated sediment sample compared to the decontaminated sedi-

ment sample). The concentration of total PCBs in the decontaminated sediment was above the 2008 NJRDCSRS of 200 µg/kg, but below the standard of 490 µg/kg in place at the time of the demonstration project. Dioxin/furan concentrations were reduced by approximately 85% through the BioGenesisSM Sediment Decontamination Process. These results are consistent with the Raritan River and Arthur Kill results.

The concentrations of polyaromatic hydrocarbons (PAHs) in the Lower Passaic River sediment (as well as the Arthur Kill sediment) were challenging. Analytical results for samples collected during the initial operations on the sediment from the Lower Passaic River showed elevated concentrations of PAHs in the treated sediment. In addition, as discussed above, during the initial operations significant problems were encountered from trash and organic detritus such as twigs and leaves. After the secondary screen was installed, samples of the oversized material from this screen showed significantly elevated concentrations of PAHs, but the removal of the oversized material that contained the elevated levels of PAHs was not enough to have a significant impact on the concentration of PAHs entering the BioGenesisSM Sediment Decontamination Process.

The analytical results for select PAHs of samples analyzed on the optimum operating days for the sediment from the Lower Passaic River are presented graphically in Figure ES-6. The concentrations of benzo(a)pyrene and benzo(a)anthracene in the treated sediment samples were above the NJRSCS. The concentrations of the PAHs in the decontaminated sediment

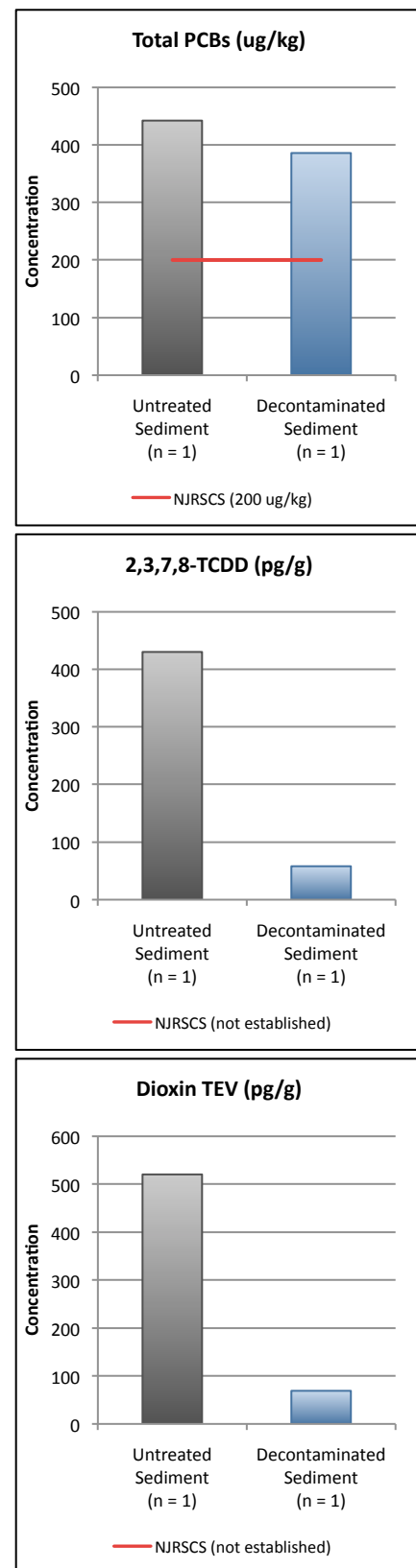
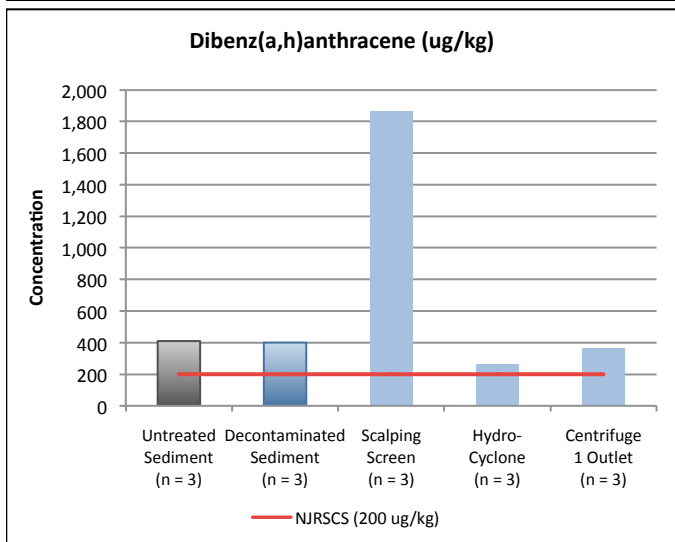
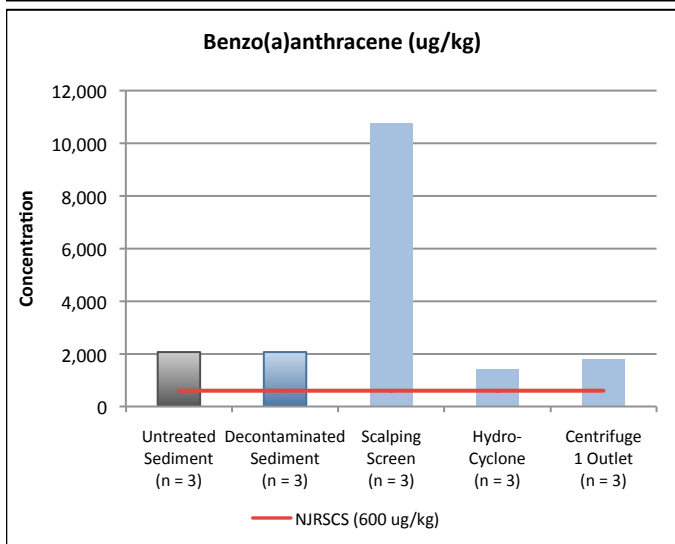
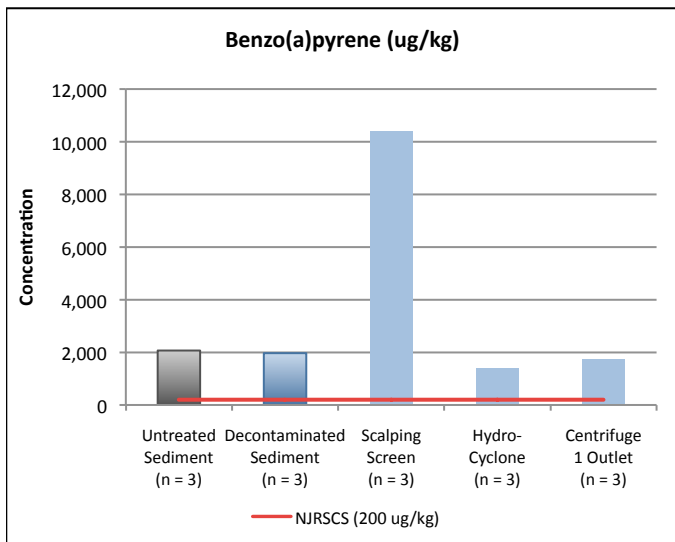

Figure ES-5 Analytical Results for PCBs and Dioxins – Lower Passaic River Sediment



samples were statistically similar to the concentrations of PAHs in the untreated sediment (see section 4.3 of the report for a discussion of the statistical analysis). Comparing the concentrations of PAHs in subsamples of the decontaminated sediment from the scalping screen, hydrocyclones and centrifuge 1, it can be observed that the coarser material (from the scalping screen) had much higher levels of PAHs than the finer grain material (from the hydrocyclones and the centrifuge). This is counter intuitive since contaminants are presumed to be present on the surface of the sediment particles, and the surface area per unit weight of the finer grain-sized particles is significantly higher than the surface area per unit weight of larger grain-sized particles. Therefore, finer-grained particles would have higher concentrations of contaminants. This observation, along with the elevated concentrations of PAHs in the oversized from the secondary screen lead to a theory of the presence of the PAH contamination. It seems that the PAHs are adsorbed to, or absorbed in, the organic detritus material mixed with the sediment.

Figure ES-6 Analytical Results for PAHs – Lower Passaic River Sediment

ES.6 Bench-Scale Testing of Lower Passaic River Sediment

A review of the analytical results from the demonstration project for organic contaminants shows that PAH and PCB concentrations were only marginally reduced, and dioxin concentrations were reduced in the sediment with higher efficiency. To investigate the reasons for the variations between the organic contaminants removal efficiencies and develop methods for improving them, BioGenesis conducted a series of bench tests using dredged material from the Lower Passaic River. The tests were conducted at the BioGenesis testing facility in Milwaukee, Wisconsin, from January through May 2008. Iterative testing allowed the use of a variety of chemical formulations and facilitated the operation of various equipment configurations during processing.

As discussed previously, the BioGenesisSM Sediment Decontamination Technology is a physical/chemical process that uses impact forces and chemical forces to strip contaminants from the surface of sediment particles and suspend them in the water phase where they can be separated from the sediment. The physical characteristics of the sediment particles (i.e., density, porosity, grain size, chemical structure, etc.) play a large role in the performance of the decontamination process. However, none of these characteristics would explain the difference in treatment of different organic contaminants from a single sediment source. The chemical and physical characteristics of the contaminants are the differentiating factors.

Several characteristics of organic contaminants that can affect the distribution of the contaminants in the sediment matrix include the affinity for organic carbon (K_{oc}), affinity for different grain size fractions of sediment particles, polarity and/or solubility in water, and molecular rigidity. A review of these characteristics, coupled with observations made during the bench tests in Milwaukee, could explain the differences in removal efficiencies.

All three classes of compounds are somewhat insoluble in water with PAHs and PCBs being only slightly soluble and dioxins being practically insoluble. Also all

three classes of organic compounds have high affinities towards organic matter with PCBs and dioxins having higher affinity than PAHs. Finally, dioxins have molecules that are more rigid than PCBs and PAHs.

All of these factors, along with the high TOC concentrations in the Lower Passaic River and Arthur Kill sediment, could indicate the nature of the organic contaminants in the sediment. The PAHs, dioxins, and PCBs could be primarily absorbed in the organic material with lesser amounts adsorbed to the sediment surface. When processed through the BioGenesisSM Sediment Decontamination Process, the impact forces have the largest effect on the rigid contaminants adsorbed to the sediment particles. Once the contaminants are dislodged from the particle surface, the solubility of the contaminants in water will dictate where the contaminants will end up. Insoluble contaminants will tend to re-attach to the solid surface of the sediment particles. The added washing chemicals help to overcome the lack of solubility of certain organic contaminants and allow them to be suspended in the water phase. The efficiency of the collision impact forces is reduced for contaminants absorbed in organic matter (plant and animal based fibrous material), which is porous, spongy, and less dense than sediment particles. Higher molecular rigidity will help improve the impact efficiency.

Since harbor sediment is such a complex material, contaminated with a variety of contaminants, several processing steps and solid/liquid separation steps are required to decontaminate the sediment. During the demonstration project the secondary screen removed a portion of the large organic fiber and the chemical analysis of this material showed it was highly saturated with PAHs. However, the screen couldn't remove the fine organic material (short fibers), which was removed in the solid/liquid separation steps.

During the bench testing in Milwaukee, the untreated sediment, treated sediment, and residual inorganic solids in the treated sediment (particles which were left after burning the treated sediment in a laboratory oven at 1,000° C) were examined under a microscope. These examinations showed that there was a significant

portion of organic matter remaining in the treated sediment. The level of PAHs and other organic contaminants in the treated sediment appears to be proportional to the percentage of organic matter remaining in the sediment following treatment. In addition, settling tests of the treated sediment showed that the organic matter settles at about the same rate as the sediment particles. This implies that solid/liquid separation through hydrocyclones and centrifuges can't differentiate between the cleaned sediment particles and the PAH-laden organic fiber.

In May 2008, the final bench experiments in Milwaukee showed that a micro-floatation technique using fine air bubbles (30 to 40 microns) would allow the PAH contaminated organic fibers to be floated and separated from solid particles with similar densities. Analytical samples of the recovered organic fibers showed total PAH concentrations as high as 110,000 µg/kg, while samples of the recovered sediment particles showed concentrations of 2,000 to 8,000 µg/kg. Thus for sediment where there is a significant fraction of organic material in the sediment and PAHs are a compound of concern, micro-floatation will be implemented as part of the solid/liquid separation step.

Micro-floatation is routinely used in water and wastewater treatment for the removal of non-aqueous organic material. The BioGenesis™ Gondola utilizes micro-floatation to separate light organic material and non-aqueous organic material from the sediment slurry. The functionality of the BioGenesis™ Gondola was successfully tested during the 1999 Pilot Demonstration Project, but there was no significant amount of free-phase organic material or organic detritus in the sediment slurry during that project. Since no free-phase organic material was removed from the sediment in the 1999 Pilot Demonstration Project, BioGenesis™ Gondola was not utilized in the Full-Scale Demonstration Project.

ES.7 Manufactured Soil Demonstration

An important goal of the demonstration project was the generation of a treated sediment product that can be used for unrestricted beneficial uses. The decontaminated sediment from the BioGenesisSM Sediment Decontamination Process consists of soil/sediment particles with varying grain sizes with little or no organic matter to support plant life. It can be used as a primary amendment to create manufactured topsoil.

In the fall and winter of 2008, a demonstration project was completed at Montclair State University (MSU) with approximately 20 cy of the decontaminated sediment from the Lower Passaic River. The decontaminated sediment was blended with sand, organic matter, and clay, using approximately 40% decontaminated sediment by dry weight, to produce topsoil with the proper physical and chemical properties. The manufactured topsoil was evaluated by Rutgers, The State University of New Jersey, in the New Jersey Agricultural Experiment Station to determine its value as a soil. The results of the testing by Rutgers showed the topsoil to meet typical soil criteria for pH, macro and micronutrients, electrical conductivity, grain size distribution, etc. In addition, the manufactured topsoil was sampled for chemical analyses and showed no concentrations of contaminants above the NJRDCSRS. The analytical results for select contaminants for samples of the manufactured soil are presented graphically in Figures ES-7, ES-8, and ES-9. The manufactured topsoil

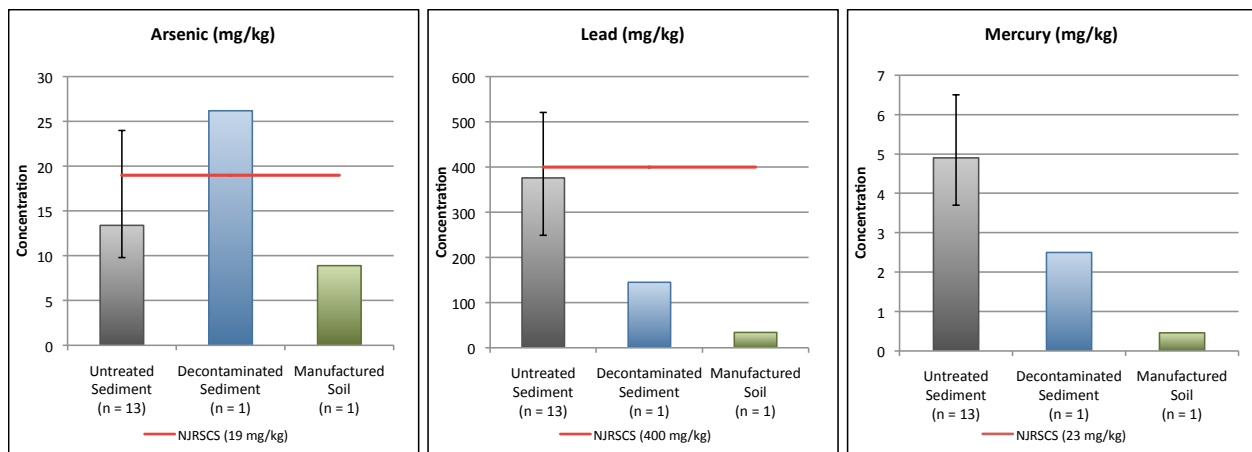

Figure ES-7 Analytical Results for Metals – Manufactured Soil

was used in the fall of 2009 to create an interpretative walk outside of Mallory Hall at MSU as part of an environmental management sediment sustainability demonstration project.

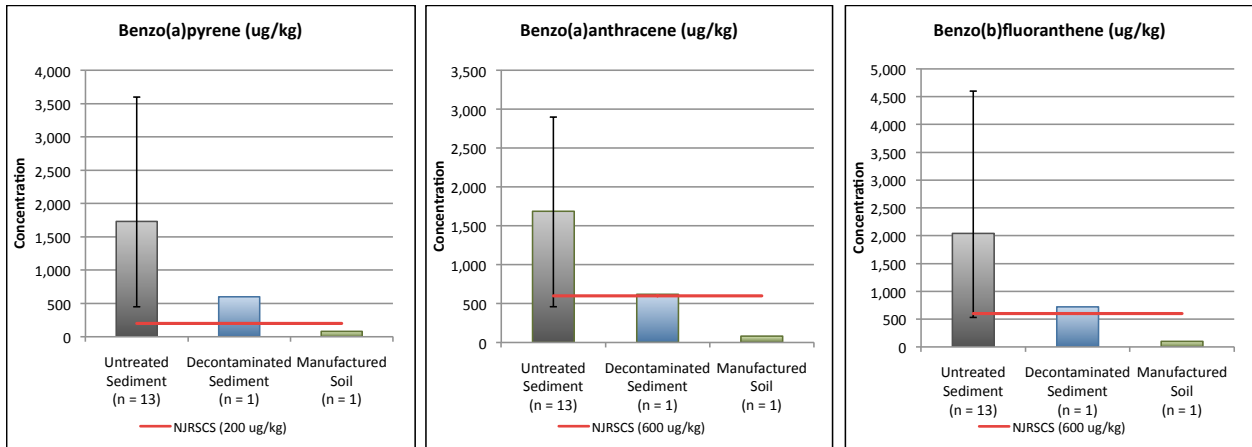

Figure ES-8 Analytical Results for PAHs – Manufactured Soil

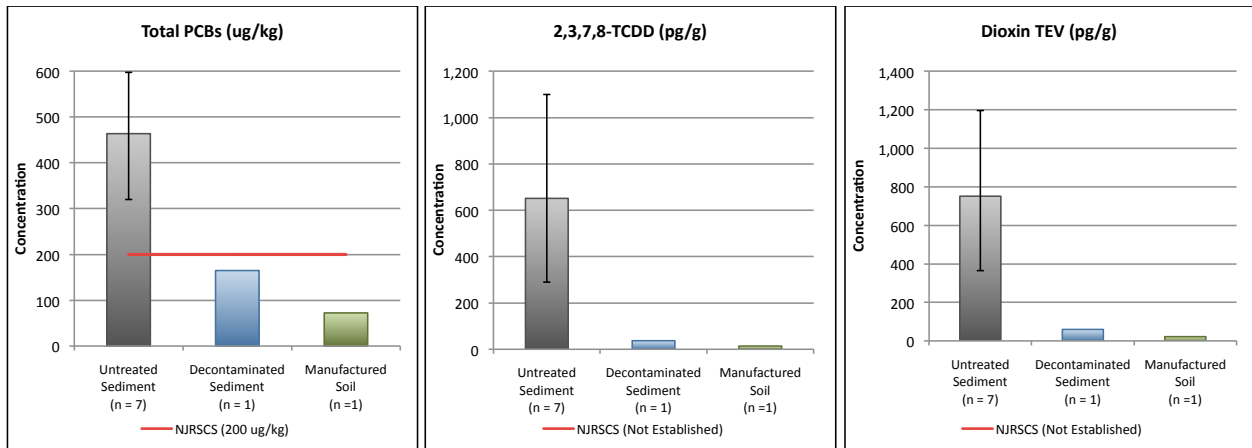

Figure ES-9 Analytical Results for Total PCBs and Dioxins – Manufactured Soil

ES.8 Commercial-Scale System Recommendations

Based on observations made during the demonstration test, a few changes are recommended to the material handling aspect of the system. A commercial-scale treatment operation would require a more efficient front-end storage system for offloading, screening, and transferring the sediment. Secondly, a commercial-scale system would have redundant piping and pumping systems that would allow the

system to operate while one component was serviced or repaired. Micro-flotation would be included in the solids/liquid separation step to remove organics prior to hydrocyclones and centrifuges for recovery of solids for beneficial use. Finally, rubber lined pumps will need to be used to minimize the maintenance requirements.

The site for a commercial-scale BioGenesis sediment decontamination facility would need to be located in the NY/NJ Harbor with deepwater barge access for the delivery and offloading of the dredged material. A minimum of 25 acres will be required for a 40 cy per hour facility (nominally 250,000 cy/year) and possibly as much as 35 acres for a 80 cy/hr facility (nominally 500,000 cy/year for storage of untreated and treated sediment. The process building will be approximately 350 ft by 100 ft for a 40 cy/hr facility and 350 ft by 150 ft for an 80 cy/hr facility with a minimum of 25 ft of clear span.

ES.9 Projected Commercial-Scale Costs

This technology demonstration project was developed to help determine what a commercial-scale facility would cost to operate continuously. Permanent operational costs were derived from the day-to-day cost and labor tracking data gathered during the demonstration test. The projected unit costs for decontamination and beneficial use of NY/NJ Harbor navigational dredged material utilizing the BioGenesisSM Sediment Decontamination Technology are:

40 cy/hour facility (250,000 cy/year)	\$ 58.82/cy
80 cy/hour facility (500,000 cy/year)	\$ 51.33/cy

These costs represent a total “tipping cost” for the decontamination and beneficial use of dredged material, from the offloading of the sediment from the delivery barges to the marketing and beneficial use of the manufactured soil. The costs are very competitive compared to the contracts awarded by the USACE in the past few years for the dredging and upland disposal of navigational dredged material in the

NY/NJ Harbor (estimated upland costs ranging from approximately \$53/cy to \$412/cy).

ES.10 Conclusions

Based on the results of the demonstration test, the following conclusions have been made:

- **The BioGenesisSM Sediment Decontamination Process Can Meet the New Jersey Soil Cleanup Standards** – Analytical tests on the treated sediment from the three different dredged material sites demonstrated significant reductions in dioxins, PCBs, and all heavy metals except arsenic. Some contaminants were readily removed and others, such as PAHs, were difficult to remove. However, we have concluded that the BioGenesisSM Sediment Decontamination Process can be adjusted to treat maintenance dredged material to meet the NJRSCS with the exception of naturally occurring heavy metals such as arsenic.
- **Projected Treatment Costs are Consistent with Current Prices for the Management of Contaminated Navigation Dredged Material** – At commercial scale (500,000 cy/year) the cost to decontaminate sediment using the BioGenesisSM Sediment Decontamination Process is approximately \$50.00/cy. This cost is very competitive compared to recent contracts awarded by the USACE for the upland disposal of navigational dredged material in the NY/NJ Harbor.
- **Technology Assessment** – The BioGenesisSM Sediment Decontamination Technology is ready for commercial application to process contaminated navigational dredged material. It can reliably decontaminate navigational dredged material to produce a manufactured soil for beneficial use.

1 INTRODUCTION

1.1 Project Overview

Presented in this report are the results of a Full-Scale Demonstration of the BioGenesisSM Sediment Decontamination Technology conducted on dredged material from the New York/New Jersey Harbor. BioGenesis Washing BGW, LLC (BioGenesis), under New Jersey Department of Transportation (NJDOT), Office of Maritime Resources (OMR) Contract Number OMR-FAO9417327-01, performed the demonstration project. Certain services for the completion of the project were contracted directly by Brookhaven National Laboratory (BNL) on behalf of the US Environmental Protection Agency (USEPA).

The scope of work for the demonstration project included:

- Site selection conducted from January 2002 through March 2004.
- Permitting and approvals conducted from July 2004 through December 2005.
- Planning, design, and procurement activities conducted from March 2004 through August 2005.
- Construction and shakedown of a temporary full-scale decontamination facility to handle treatment of raw sediment and process wastewater conducted from July 29 through December 22, 2005.
- Operating the BioGenesis facility to decontaminate approximately 14,724 cubic yards (cy) of contaminated sediment on a full-scale basis from January 3 through May 4, 2006.
- Demobilization of full-scale equipment and decontamination of the Upfront Storage Facility conducted from May 8 through December 12, 2006.
- Transporting of the treated sediment to an off-site location for beneficial use conducted from July 10 through October 26, 2006.
- Demonstration of the beneficial use of decontaminated dredged material conducted from July 9, 2008 through December 19, 2008.

1.2 Background

Since the nineteenth century, routine dredging of the New York/New Jersey (NY/NJ) Harbor has been necessary to maintain the water passages and berthing channels to accommodate modern shipping. These water channels, which have a natural depth averaging 19 feet, require sediment removal to depths of at least 40 feet to allow for safe navigation of vessels through the harbor. With the introduction of larger container ships, the channels will require dredging to depths of 50 to 55 feet for the Port of NY/NJ Harbor to remain competitive in the world market.

Historically, maintenance dredged material from the NY/NJ Harbor, which amounts to approximately 2 to 4 million cy annually, has been disposed of at a designated location in the Atlantic Ocean off the New Jersey coast (the “Mud Dump” Site). Changes to the ocean disposal testing criteria in 1991, however, have set stricter standards as to which sediment may be disposed at sea. In 1997, EPA terminated the use of the historic Mud Dump Site. The Mud Dump, and surrounding area, is now being capped with available “clean” or Unrestricted Category 1 dredged material from current and future NY/NJ Harbor navigation maintenance projects and is being referred to as the Historical Area Remediation Site (HARS). Based on the concentrations of heavy metals, organic compounds, and other chemical constituents present in the NY/NJ Harbor sediments, the U.S. Army Corps of Engineers (USACE) estimates that approximately 1.1 million cy of the material projected to be dredged annually through year 2040 is not suitable as HARS remediation material and will require an alternate disposal and/or treatment method. (USACE, 2008).

Under the Water Resources Development Acts of 1992 (Section 405C) and 1996 (Section 226), Congress authorized funding to develop a Sediment Decontamination Demonstration Program with the goal of demonstrating one or more facilities with the capacity to commercially decontaminate up to 500,000 cy of contaminated dredged material annually from the NY/NJ Harbor (referred to as the WRDA Decontamination Program). The WRDA Decontamination Program emphasizes

rapid development of environmentally responsible and cost-effective methods for the decontamination of dredged material. The USEPA – Region 2 and the USACE – New York District share joint responsibility of the WRDA Decontamination Program, with EPA acting as the program lead. Collaborating with EPA and USACE is the U.S. Department of Energy (DOE) – BNL, which conducts technical project management and contracting/ procurement services for the WRDA Decontamination Program through Interagency Agreements with the EPA.

The WRDA Decontamination Program has progressed through bench-scale and pilot-scale demonstrations of various technologies and is now moving toward commercialization of decontamination technologies. (Federal funding from the WRDA legislation provides assistance to the commercialization process, but the private sector must provide the capital needed for facility construction and operations.) This step-wise procedure has resulted in a reduction of the number of participants through several factors including technical performance, demonstration costs, private-public cost sharing, beneficial use of treated material, and evaluations of the business potential for commercial-scale decontamination. The BioGenesisSM Sediment Decontamination Technology was selected to proceed from pilot-scale to full-scale demonstration by the WRDA Decontamination Program.

Similar to the WRDA Decontamination Program, the NJDOT also has a mission of promoting the development of commercially viable beneficial use technologies including sediment decontamination technologies. The OMR of the NJDOT serves as the primary advisory body and lead agency for support of New Jersey’s maritime industry. In this role, the State of New Jersey supports research and development and investigates innovative dredged material management technologies to ensure continued development and growth of New Jersey’s Maritime Transportation System. OMR has been working closely with the WRDA Decontamination Program to evaluate new sediment/dredged material decontamination technologies with beneficial end-use products. Through the New Jersey Sediment Decontamination Technology Demonstration Program, the OMR is continuing the work of the WRDA

Decontamination Program and fostering the startup of businesses that can provide cost-effective sediment decontamination on a commercial scale. As part of this effort, the State of New Jersey solicited proposals for a commercial-scale demonstration project to decontaminate and beneficially use sediments from the NY/NJ Harbor. BioGenesis responded to the request and the BioGenesisSM Sediment Decontamination Technology was selected as one of the technologies to be demonstrated at full-scale. Since both the EPA and OMR are coordinating their efforts for the demonstration of sediment decontamination technologies, this project was authorized and funded under both entities.

1.3 Project Objectives

The main objectives of the sediment decontamination demonstration project were:

- to verify that the BioGenesisSM Sediment Decontamination Process is capable of consistently treating contaminated sediment such that it meets the New Jersey Residential Direct Contact Soil Remediation Standards (NJRDCSRS) and thus generate a treated sediment product that can be used for unrestricted beneficial uses,
- to verify that the BioGenesisSM Sediment Decontamination Process is capable of performing reliably at a cost consistent with the current prices for management of non-HARS suitable navigational dredged material, and
- to estimate the commercial-scale sediment treatment costs for the BioGenesis process at the throughput rate of 40 cy per hour (250,000 cy per year) and 80 cy per hour (500,000 cy per year).

1.4 Project Team

BioGenesis retained several firms to provide specific services throughout the execution of the demonstration project. Presented in Figure 1-1 is a chart showing the organization and responsibilities of the various organizations comprising the project team. BioGenesis Enterprises, Inc. was retained to provide technology, core processing equipment, chemicals, and management personnel. Montgomery

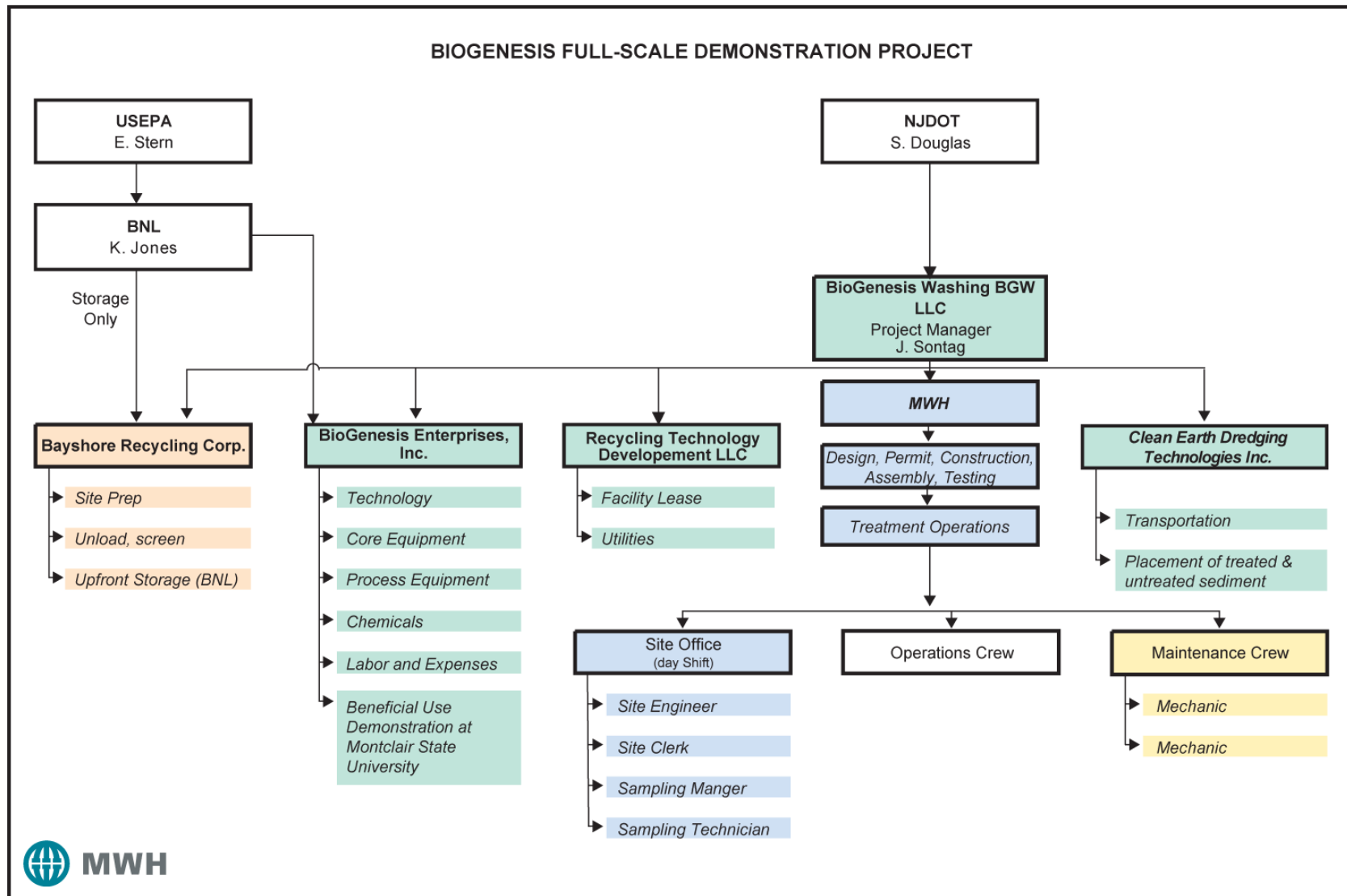

Figure 1-1 Project Organization

Watson Harza (MWH) was retained to perform design, permitting, construction and operating services. Bayshore Recycling Corporation (Bayshore) was subcontracted by BioGenesis to perform offloading and screening services, as well as site preparation, operations, and demobilization services. Bayshore was also contacted directly by BNL to provide upfront storage of the untreated sediment for the project. Clean Earth Dredging Technologies, Inc. (CEDTI) was contracted to provide placement of the treated and untreated sediment from the demonstration project. The site where the demonstration test was conducted was leased from Recycling Technology Development, LLC.

1.5 Organization of the Full-Scale Demonstration Project Report

This report is divided into seven sections. Section 1 has an introduction with background information for the project. Section 2 describes the BioGenesisSM Sediment Decontamination Technology and summarizes additional demonstration programs. Section 3 focuses on the demonstration project facilities and supporting activities. Section 4 has a discussion of the operational observations and the data collected during the project. Section 5 contains recommendations that can be used for designing and operating a permanent commercial-scale system as well as cost projections for the commercial-scale facility. Section 6 contains a presentation of conclusions to the demonstration project, and a summary of recommendations. Section 7 is a list of references cited in the report.

Appendix A contains select photographs taken during the execution of the demonstration project. Appendix B contains summary tables of the analytical results, and the project Data Validation Report is contained in Appendix C. Monthly wastewater discharge monitoring reports are included in Appendix D, and the results of bench-scale testing conducted in the spring of 2008 are presented in Appendix E.

2 BIOGENESISSM SEDIMENT DECONTAMINATION TECHNOLOGY

2.1 Technology Description

The BioGenesisSM Sediment Decontamination Technology is a patented ambient temperature decontamination process for coarse- and fine-grained sediment, which uses impact forces and proprietary chemicals to remove organic and inorganic contamination. The resulting decontaminated sediment can be used to produce high-end topsoil or other construction grade products.

The BioGenesisSM Sediment Decontamination Technology consists of eight main processing steps including:

- **Dredged Material Preparation** – offloading, screening, and temporary storage
- **Preprocessing** – addition of proprietary washing chemicals and disaggregation of the sediment particles from each other and from the loosely-associated naturally occurring organic material (called biomass)
- **Application of Collision Impact Forces** – stripping the biofilm layer and adsorbed contaminants from the solid sediment particles
- **Floatable Organic Material Removal** – removal of light organic material using micro-floatation
- **Organic Contaminant Oxidation** – destruction of organic contaminants using enhanced oxidation (cavitation/oxidation)
- **Solid/Liquid Separation** – recovery of the cleaned sediment particles
- **Wastewater Treatment** – pre-treatment of the resulting wastewater and discharge to the local publicly owned treatment works
- **Soil Manufacturing** – blending of the decontaminated sediment with other raw materials to produce a high-end topsoil

An overview of the general BioGenesis process is shown in Figure 2-1. The following is a description of the individual processing steps:

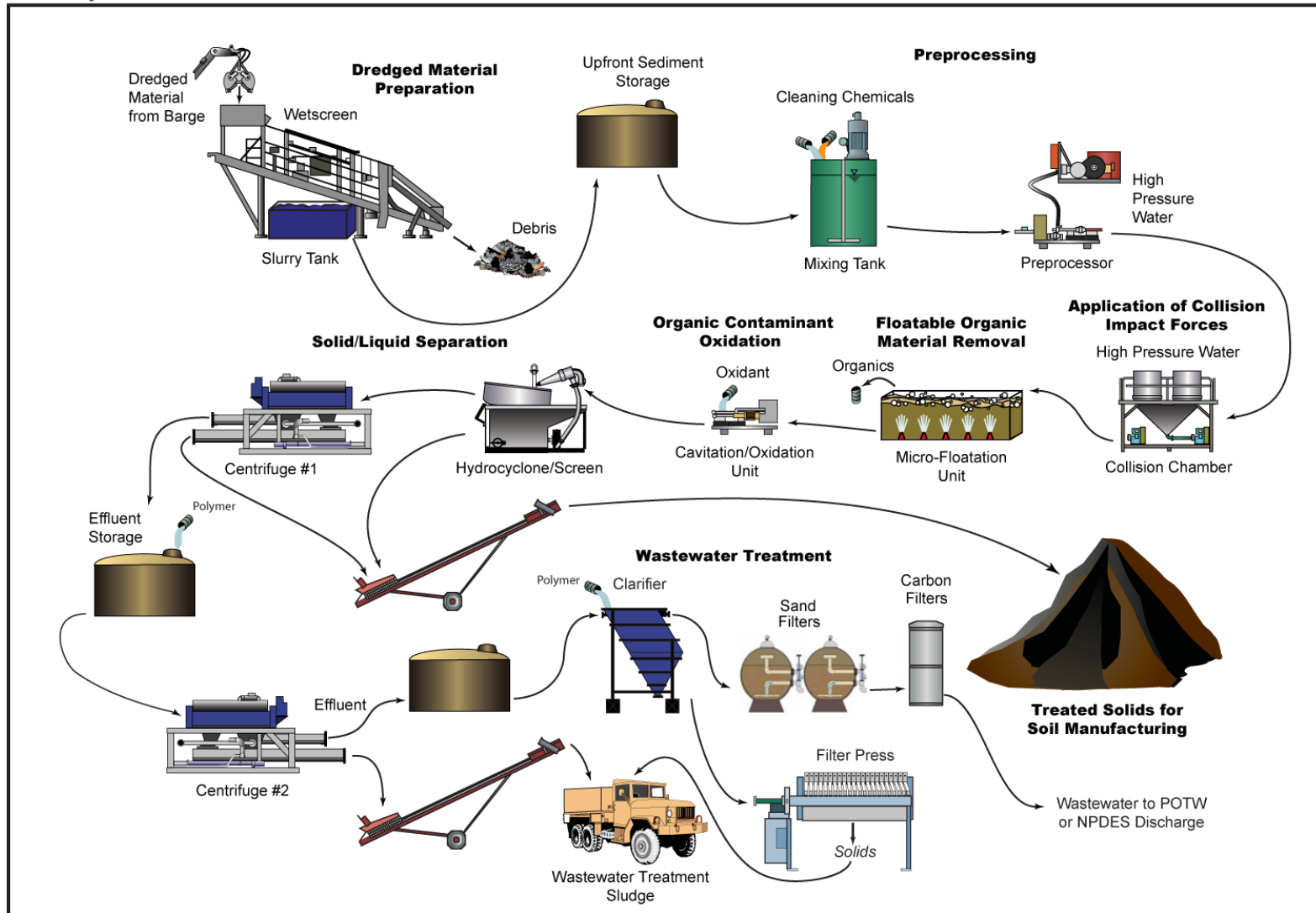

Figure 2-1 General Overview of the BioGenesisSM Sediment Decontamination Process

Dredged Material Preparation – The first step of the BioGenesisSM Sediment Decontamination Process involves the preparation of the sediment. This includes offloading, screening, and storage of the sediment. The sediment is screened to remove any rocks and debris greater than ¼ inch using a wet screener. The oversized material is rinsed on top of the screen and can be sorted and recycled and/or disposed. The screened material is then stored prior to processing.

Preprocessing – Next, the screened sediment is pumped from the storage system to the treatment facility where it is mixed with proprietary specialty chemicals such as surfactants, chelating agents, and defoamers. The specialty chemicals are added at this stage to prepare the sediment for decontamination by decreasing the affinity among contaminants, sediment solids, and naturally occurring organic material.

The sediment with the added proprietary chemicals is then pumped to the BioGenesisTM Preprocessor unit, which uses physical forces through high-pressure water (up to 10,000 pounds per square inch or psi) to disaggregate the sediment particles from each other and from the loosely associated naturally occurring organic material. The result is that clumped particles are disaggregated into the sediment slurry and the naturally occurring organic material is fractionated and transferred to the water phase.

Application of Collision Impact Forces – The sediment slurry from step 2 is pumped to the BioGenesisTM Collision Chamber where high-pressure water is used to create impact forces to strip the biofilm layer and adsorbed contaminants from the individual solid/sediment particles. After the BioGenesisTM Collision Chamber, fractionated biofilm and contaminants that were adsorbed to the individual solid particles, as well as naturally occurring organic material and biofilm, are transferred to the aqueous phase.

Floatable Organic Material Removal – Next the floatable organic material is removed using micro-floatation. This material includes free-phase petroleum-based material, if any, as well as light organic detritus (leaves, twigs, etc). The floatable

Organic Removal step was not used during the Full-Scale Demonstration Project, but was tested and evaluated under previous full-scale testing programs.

Organic Contaminant Oxidation – Following the Floatable Organic Material Removal step, remaining organic contaminants are destroyed using enhanced oxidation, which is accomplished through a combination of cavitation and chemical oxidation. Hydrogen peroxide, a strong oxidizing agent, is added to the sediment slurry upstream of the BioGenesis™ Cavitation/Oxidation system. Cavitation, created within the BioGenesis™ Cavitation/ Oxidation unit, occurs when air bubbles created in the slurry implode. The implosion of the air bubbles enhances the ability of hydrogen peroxide to oxidize organic molecules.

Immediately after the cavitation/oxidation step, the slurry consists of:

- washed solid particles,
- residual organic materials in the aqueous phase that may still contain some organic and inorganic contaminants,
- inorganic contaminants in the water phase, and
- water that contains the majority of contaminants (primarily inorganic constituents) desorbed from the soil/sediment solids and organic material.

Solid/Liquid Separation – At this stage, the slurry is ready for solid/liquid separation, which results in a decontaminated solid fraction and a liquid fraction that contains inorganic contaminants, residual un-oxidized organic contaminants, naturally occurring organic material, and residual sediment particles. Unless solid/liquid separation is performed shortly after Step 4, the contaminant partitioning process will reinitiate between the cleaned solids and the contaminant-enriched liquid. This means that any inorganic contaminants and un-oxidized organic contaminants, which are suspended in the liquid fraction, are candidates to be re-adsorbed/scavenged onto the cleaned solid particles. Thus, the cleaning process is partially reversible, with the reversal being caused by the particle-reactive characteristics of these contaminants.

The solid/liquid separation step includes (a) a primary settling device, a hydrocyclone in combination with wet screens, followed by (b) a secondary settling device, a centrifuge, and potentially (c) a third settling device, a filter press. The treated sediment solids separated from the aqueous phase are then stockpiled prior to reuse.

Wastewater Treatment – The wastewater from the solid/liquid separation step contains inorganic and organic contaminants, naturally occurring organic material, and residual fine-grained sediment particles. Standard wastewater treatment processes are used to remove the contaminants from the wastewater prior to discharge. Typically a filter cake is produced which can be recycled, retreated, and/or disposed depending on the concentration of contaminants. The treated wastewater is discharged to the local publicly owned treatment works, or alternatively, to a surface water body, if allowed under an applicable National Pollutant Discharge Elimination System (NPDES) permit or other appropriate authorization.

Soil Manufacturing – The decontaminated solids that were separated from the slurry in the solid/liquid separation step are then used to create a beneficial use product. The decontaminated sediment is blended with a variety of raw materials to produce a topsoil product that can be sold to offset some of the treatment costs.

2.2 Additional Technology Demonstration Projects

The BioGenesisSM Sediment Decontamination Technology has been tested and demonstrated under a series of projects starting in 1992. The full-scale demonstration project described in this report is the culmination of these testing and demonstration projects and is the largest scale demonstration project performed to date. The BioGenesisSM Sediment Decontamination Technology has evolved over the past 17 years as sediment with different contaminants and different physical properties have been processed. The following is a summary of

the results of the testing and demonstration projects performed to date. For more information, refer to the individual project reports.

1992 EPA SITE Program Bench Testing – In November 1992, BioGenesis performed bench-scale treatability testing on coarse-grained soil contaminated with crude oil, under the USEPA Superfund Innovative Technology Evaluation (SITE) program. The results of this testing indicated that aeration in the BioGenesis™ Gondola with specialty washing chemicals is efficient in decontaminating coarse-grain particles, but that additional technology development was needed for the decontamination of fine-grained particles. (USEPA, 1993)

1993 Thunder Bay Sediment Bench Testing – In 1993, under the Canadian Wastewater Technology Centre, the BioGenesisSM Sediment Decontamination Technology was tested on sediment from Thunder Bay Harbor, Ontario, Canada. The sediment was primarily silt with some clay and was contaminated with high concentrations of polyaromatic hydrocarbons (PAHs). The results of this study proved that the BioGenesis™ Collision Chamber is effective for the decontamination of fine grain sediment particles. (BioGenesis, 1993) (Environment Canada, 2000).

1995 - 1997 WRDA Decontamination Program Bench Studies – From 1995 through 1997 a series of four bench studies were conducted under the WRDA Decontamination Program for the USEPA and BNL. Dredged material processed during these bench tests was collected from Newark Bay in the NY/NJ Harbor and Newtown Creek, New York. The sediment was fine-grained silt and clay and was contaminated with PAHs, polychlorinated biphenyls (PCBs), heavy metals and dioxins. Several parameters were tested during this series of bench tests in order to further develop the BioGenesisSM Sediment Decontamination Technology. The results of the testing showed that the BioGenesisSM Sediment Decontamination Technology is effective in decontaminating typical NY/NJ Harbor sediment and that the

technology was ready for large-scale pilot testing. The results of the bench testing were summarized in a report prepared by BioGenesis for BNL and USEPA Region 2 in 1998 (BioGenesis, 1998).

1999 Pilot Demonstration Project – From November 1998 through March 1999, BioGenesis conducted a 700 cy dredged material pilot demonstration of the BioGenesisSM Sediment Decontamination Technology utilizing full-scale core processing equipment in Kearny, New Jersey. The Pilot Demonstration Project was conducted on dredged material from the Stratus Petroleum Corporation – Newark Terminal Site located in Newark, New Jersey in upper Newark Bay, along the Lower Passaic River. The sediment was very fine-grained material (52% silt, 42% clay, and 4% sand) with relatively low concentrations of inorganic and organic contaminants. Based on the data collected during the 1999 Pilot Demonstration Project, the following conclusions were drawn:

- The BioGenesisSM Sediment Decontamination Technology can effectively reduce concentrations of organic and inorganic contaminants from NY/NJ Harbor dredged materials to regulatory soil standards for beneficial use.
- The BioGenesisSM Sediment Decontamination Technology pilot-scale equipment has the ability to adjust the level of treatment by varying retention times, chemical addition ratios, etc. This agrees with results from previous bench-scale tests.
- Treated sediment can be beneficially used in a manufactured soil product that can be marketed in the NY/NJ Harbor area.
- Financial projections of commercial-scale operations indicate the BioGenesisSM Sediment Decontamination Process can be an economically viable solution for the management of NY/NJ Harbor dredged material.

The results of the 1999 Pilot Demonstration Project were compiled in the report: *BioGenesisSM Sediment Washing Technology, Full-Scale 40 cy/hr*

Sediment Decontamination Facility for the NY/NJ Harbor Region, Final Report on the Pilot Demonstration Project. (WESTON, 1999)

2002 Kai Tak Approach Channel, Hong Kong, Bench Test – In 2002 BioGenesis performed bench-scale treatability testing of the BioGenesisSM Sediment Decontamination Process on sediment from the Kai Tak Approach Channel in Hong Kong. The purpose of the testing was to evaluate the technology for use in reclamation in the Far East projects with sediments impacted by high organic content, various dissolved metals, and organic micro-pollutants. The results achieved during the treatability tests showed that, for both organic and inorganic contaminants, all post treatment levels were below the regulatory levels. (BioGenesis, 2002)

2004 Venice Pilot Demonstration Project - During the winter of 2003/2004 BioGenesis performed a pilot demonstration project for the Venice Port Authority in Venice, Italy on approximately 330 cubic meters of contaminated sediment dredged from four locations in the canals in Porto Marghera, Venice, Italy. Full-scale core processing equipment was utilized in this demonstration project. The objectives of the project were to assess the ability of the BioGenesisSM Sediment Decontamination Process to achieve decontamination of sediment from several locations in the Lagoon of Venice to meet the Italian non-residential soil criteria, to determine design criteria and costs for a full scale facility, and to explore potential beneficial use products for the decontaminated sediment. These objectives were achieved during the demonstration project showing that the technology can meet the sediment treatment requirements of the Port Authority of Venice on a technical, engineering, and cost basis. The following specific conclusions have been drawn from the data gathered during the pilot demonstration project:

- The BioGenesisSM Sediment Decontamination Technology effectively reduces the overall concentrations of metals and organic materials in

the sediment from the Lagoon of Venice and can achieve the stated project clean up goals.

- The treated sediments appear to be suitable for beneficial use in brick manufacturing.

The results of the Venice Pilot Scale project are compiled in the report, *Technical Report, Pilot Demonstration Project of the BioGenesisSM Sediment Decontamination Process*. (BioGenesis Italia, 2005)

2007 Housatonic River Bench Scale Treatability Study – In 2007, BioGenesis performed bench-scale treatability tests on soil and sediment samples from the Housatonic River – Rest-of-River site in Massachusetts. The samples tested during the treatability study consisted of fine-grained soil, fine-grained sediment, and coarse-grained sediment from three different areas along the Housatonic River. The soil and sediment were impacted with elevated concentrations of PCBs. The results of the treatability testing indicated that the BioGenesisSM Sediment Decontamination Technology can effectively decontaminate coarse and fine-grained soil and sediment particles impacted with elevated levels of PCBs to the Massachusetts reuse criteria using multiple processing steps. The testing showed that subsequent processing of treated sediment particles can continue to achieve contaminant removals indicating that there is no limit to the level of contamination treatable using the BioGenesisSM Sediment Decontamination Technology. The results of the Housatonic treatability study tests are described in the bench report (BioGenesis, March 2008) and the supplemental report (BioGenesis, June 2008).

2008 NamDong Retardation Basin, South Korea, Bench Scale Treatability Study – In 2008, BioGenesis performed bench-scale treatability tests on sediment from the NamDong Retardation Basin in Incheon City, South Korea. The NamDong Retardation Basin is located in an industrial area in the southern portion of Incheon City and accepts storm water runoff from the

industrial area and provides settling of sediment and debris prior to discharge of the storm water to the West Sea. The sediment tested was primarily sandy to clayey silt with elevated levels of total petroleum hydrocarbons (TPH) and heavy metals. The bench-scale treatability study showed that the BioGenesisSM Sediment Decontamination Technology can successfully decontaminate the NamDong Retardation Basin sediment to meet the regulatory criteria. (BioGenesis, October 2008).

The step wise development of the BioGenesisSM Sediment Decontamination Technology from bench scale testing starting in 1995 to the full-scale demonstration project discussed in this report has resulted in a proven process that is capable of decontamination and beneficial use of NY/NJ Harbor navigational dredged material. Coupled with the experience gained with bench and pilot work on different sediment matrixes impacted by a wide range of contaminants and contaminate concentrations, the BioGenesisSM Sediment Decontamination Technology has evolved into a resilient, reliable decontamination process.

3 DEMONSTRATION PROJECT ACTIVITIES

3.1 Project Site

The selection of the site for the demonstration project was difficult due to the size and temporary nature of the project and the need for upfront storage of the untreated sediment. Several upfront storage options were considered including storage in transport barges, temporary lagoons, etc. The project site was eventually selected, because the site owner owned an ore carrier, which the project utilized as the Upfront Storage Facility.

The demonstration project site, which BioGenesis leased from Recycling Technology Development LLC, consisted of an existing warehouse facility located at 75 Crows Mill Road in Keasbey, Middlesex County, New Jersey. The site is situated along the Raritan River about five miles off exit 10 of the NJ Turnpike along route 440 (exit to Crows Mill Road) as shown in Figure 3-1. The ore carrier, which was used as the Upfront Storage Facility, was moored in the Raritan River adjacent to the site. Photographs of the project site and Upfront Storage Facility are provided in Appendix A.

3.2 Permitting and Approvals

Approvals and permits required for the sediment decontamination demonstration project were obtained from the local, state, and federal regulatory agencies by BioGenesis with assistance from EPA, NJDOT, and the New Jersey Department of Environmental Protection (NJDEP). The site owner/operator obtained necessary approvals and permits for the offloading and storage facility with assistance from BioGenesis, EPA, NJDOT and NJDEP.

Applicable agreement, approvals, and permits included, but are not limited to:

- **Lease Agreement** – BioGenesis leased the Keasbey Site for the sediment decontamination demonstration project from April 1, 2005 through June 30, 2006.

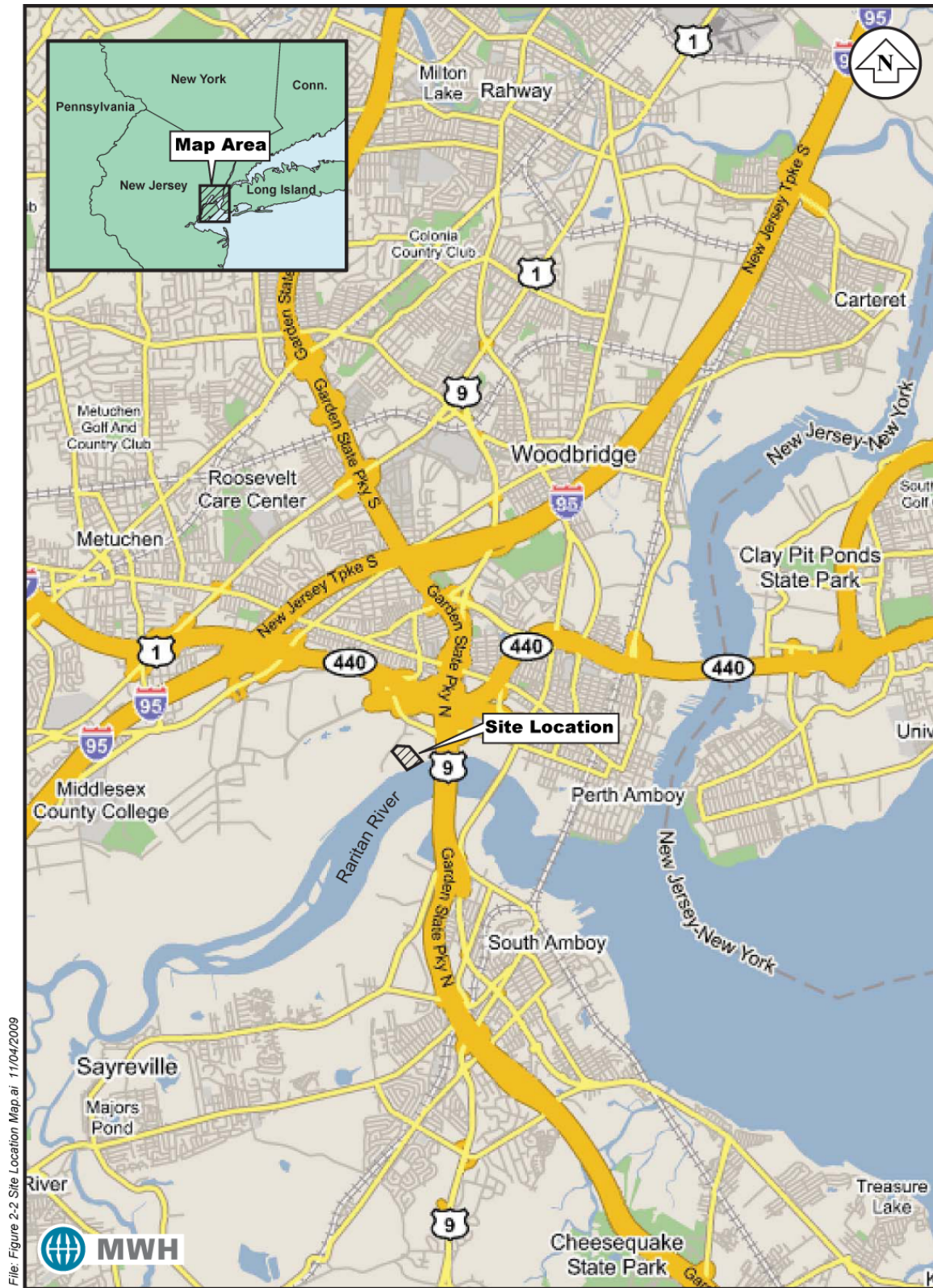

File: Figure 2-2 Site Location Map.ai 11/04/2009

Figure 3-1 Site Location Map

- **Waterfront Development Permit (WDP)** – The site owner/operator submitted permit applications for the development of the waterfront at the Keasbey facility to the NJDEP and USACE. The NJDEP issued a WDP permit and water quality certification (NJDEP File #1225-04-0013.1 WFD 040001) on November 4, 2004, and the USACE issued a permit on April 18, 2005.
- **Acceptable Use Determination (AUD)** – An AUD application for the BioGenesis Sediment Decontamination facility was submitted to the NJDEP for approval. The AUD was issued by the NJDEP, Office of Dredging and Sediment Technology, by letter dated November 17, 2004.
- **Wastewater Discharge Permit** – A permit for the disposal of wastewater generated during operations was obtained from the Middlesex County Utility Authority (MCUA), the local publicly owned treatment works (POTW), and Woodbridge Township on December 29, 2005.
- **Air Discharge Permit** – An air discharge permit application for the potential release of volatile organic compounds during the operations was approved by NJDEP on January 3, 2005.
- **WDP Modification for Emergency Dredging Operation** – During the construction of the waterfront facilities it was determined that the approach to the offloading area was too shallow to safely navigate the sediment transport scows. An application was submitted to the NJDEP and USACE for the emergency dredging of the approach area and offloading slip. The dredging operation was approved on October 20, 2005, and the permit was issued on February 28, 2006.
- **AUD for final placement of treated and untreated dredged material from the Arthur Kill and Raritan River** – An AUD application for the final placement of the dredged material sediment from the Arthur Kill and the Raritan River was submitted to the NJDEP in April 2006. The AUD was issued by the NJDEP, by letter dated June 15, 2006.
- **AUD for final placement of treated and untreated dredged material from the Lower Passaic River** – An AUD application for the final placement of the dredged material from the Lower Passaic River was submitted to the NJDEP in August 2006. The AUD was issued by the NJDEP, by letter dated September 19, 2006. A request for modification of the AUD for a final beneficial use demonstration was submitted to the NJDEP in November 2007, and a modification was issued on April 21, 2008. Final approval for placement of the manufactured soil was issued by the NJDEP on June 3, 2009.

3.3 Facility Design

MWH prepared the design for the demonstration project focusing on the use of temporary equipment and power at the site. The process flow and treatment elements were determined in collaboration with BioGenesis and the system layout was developed for the existing space at the facility.

The general design parameters for the BioGenesis sediment facility were to:

- be capable of processing sediment 24 hours per day, five days per week at an hourly throughput of 40 cy and an average plant uptime of 80%, and
- treat sediment with characteristics similar to those shown in Table 3-1 as “Typical Range NY/NJ Harbor Federal Navigation Sediment” so that contaminant concentrations in the treated sediment do not exceed the New Jersey Residential Soil Cleanup Standards (NJRSCS). Note, since the start of the demonstration project the NJDEP has issued revised New Jersey Residential Direct Contact Soil Remediation Standards (NJRDCSRS). Both sets of standards are presented in Table 3-1.

Provided in Figure 3-2 is a block flow diagram for the BioGenesisSM Sediment Decontamination Process. Note that the micro-floatation unit was not included in the process employed during the demonstration project. The following is a description of each of the treatment components designed for the demonstration project.

3.3.1 Dredged Material Offloading and Upfront Storage

As mentioned previously, the project site was selected, in part, because the site owner had purchased a bulk ore carrier, which the project could utilize as the Upfront Storage Facility for untreated dredged material. Upfront storage was required to allow offloading of the dredged material from the transport barges at a faster rate than the treatment system could process it.

Table 3-1 Typical NY/NJ Harbor Sediment Characteristics and New Jersey Residential Soil Standards

Selected Chemical Constituents	Typical Range of NY/NJ Harbor Federal Navigation Sediment¹	New Jersey Residential Soil Cleanup Standards²	New Jersey Residential Direct Contact Soil Remediation Standards³
Dioxins/Furans (pg/g)			
2,3,7,8-TCDD	0 – 529	-	-
TCDD/TCDF TEV	61 – 224	-	-
Total Polychlorinated Biphenyls (mg/kg)	0.05 – 3.32	0.49	0.2
Polynuclear Aromatic Hydrocarbons (µg/kg)			
Anthracene	233 – 57,500	10,000,000	17,000,000
Benzo(a)anthracene	151 – 23,400	900	600
Benzo(a)pyrene	214 – 19,400	660	200
Chrysene	175 – 23,500	9,000	62,000
Fluoranthene	233 – 57,500	2,300,000	2,300,000
Total PAHs	2,000 – 306,000	-	-
Pesticides (µg/kg)			
4-4'-DDD	0.1 – 2,070	3,000	3,000
4-4'-DDE	2 – 250	2,000	2,000
Metals (mg/kg)			
Arsenic	4 – 97	20	19
Cadmium	0.2 – 73	39	78
Chromium	15 – 245	-	-
Lead	17 – 580	400	400
Mercury	0.2 – 13.6	14	23
Nickel	10 – 870	250	1,600
Silver	0.15 – 16	110	390
Zinc	41 – 625	1,500	23,000
Grain Size Distribution			
Sand (> 0.0625 mm)	4% – 28%	-	-
Silt (0.0039 to 0.0625 mm)	36% – 84%	-	-
Clay (<0.0039 mm)	12% – 36%	-	-
mm	millimeters	TCDF	Tetrachlorodibenzofuran
mg/kg	milligrams per kilogram	TEV	Toxicity Equivalency Value
µg/kg	micrograms per kilogram	DDD	Dichlorodiphenyldichloroethane
pg/g	picograms per gram	DDE	Dichlorodiphenyldichloroethylene
TCDD	Tetrachlorodibenzo-p-dioxin	-	No established level

¹ From the “New York and New Jersey Federal Navigation and Private Berthing Sediment Database” which was obtained through a personal communication with Mark Reiss, U.S. EPA, Region 2, December 1999.

² NJDEP, 1999.

³ NJDEP, 2008.

The bulk ore carrier was a former Great Lakes Region vessel that was retired from service on the Great Lakes in December 2004. It was towed to New Jersey in the summer of 2005 and was moored on the banks of the Raritan River next to the demonstration facility in Keasbey, New Jersey. The vessel was 736 feet in length, 76 feet in beam, and had six cargo holds, each of varying dimensions and depths.

Sediment from the transport barges was removed using a hydraulic material handler equipped with a clamshell bucket. The excavated sediment was dropped onto a vibrating screen to remove all materials greater than ¼ inch in size. The oversized material (greater than ¼ inch) was removed and disposed. The screened sediment was pumped from the screening unit up to the deck of the ship and into a designated hold.

Sediment from different sources was stored in separate holds prior to processing and readings were taken on a daily basis to determine the volume of sediment in each hold. As sediment was removed from the ship for processing, it was necessary to move sediment from hold to hold to balance the loading in the ship.

3.3.2 Process Equipment Components

The demonstration facility was designed to treat 40 cy per hour of sediment continuously. Provided in Figure 3-3 is a process flow diagram (PFD) which illustrates the flow connections and electronic controls for the complete process. Each treatment component performed a specific function and was monitored during processing. The interconnectivity of the units is also shown on Figure 3-3.

The primary treatment components of the system were as follows:

- **Screening** – Screening was performed as the sediment was removed from the transport barge and once more as the material was transferred to Tank 101 at the beginning of the process.
- **Chemical mixing** – Washing chemicals were added to Tank 102 using metering pumps connected to bulk liquid chemical totes. The dosages of the washing chemicals were adjusted in the field by BioGenesis and the pumps

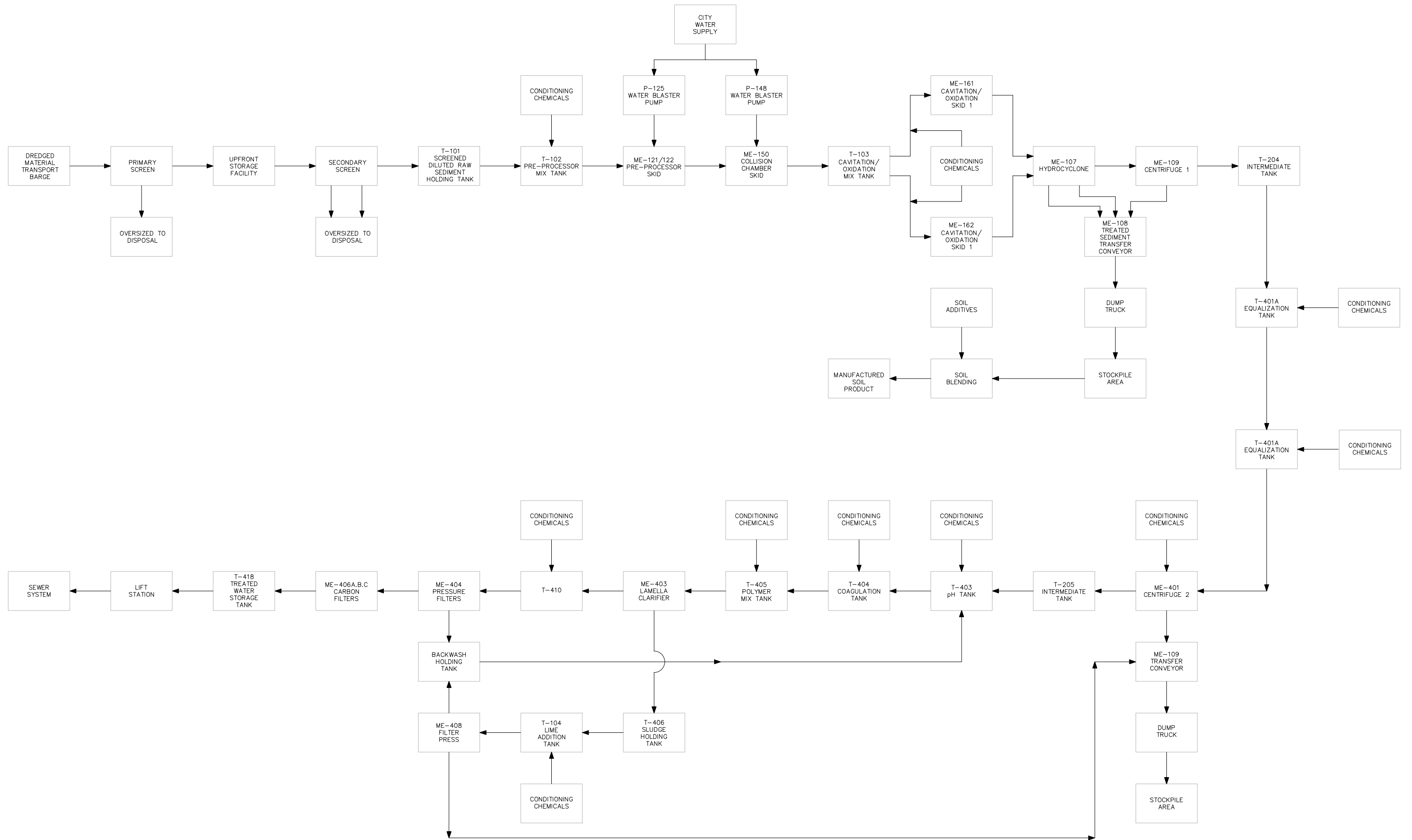

0	1/24/06	CDD	AS BUILT
1	8/10/08	JGS	ADDED PRIMARY AND SECONDARY SCREEN
2	11/4/09	JGS	ADDED SOIL MANUFACTURING
REV	DATE	BY	DESCRIPTION

SCALE	DESIGNED	CDD	01-24-06
NTS	DRAWN	CDD	01-24-06
	CHECKED	JGS	11-04-09



BIOGENESIS
 SEDIMENT DECONTAMINATION FACILITY
 NJDOT OMR DEMONSTRATION PROJECT
 KEASBEY, NEW JERSEY

FIGURE 3-2
 BLOCK FLOW DIAGRAM

SHEET
BFD
 1 OF 1

FILE: Figure 2-3 Block Flow Diagram.dwg

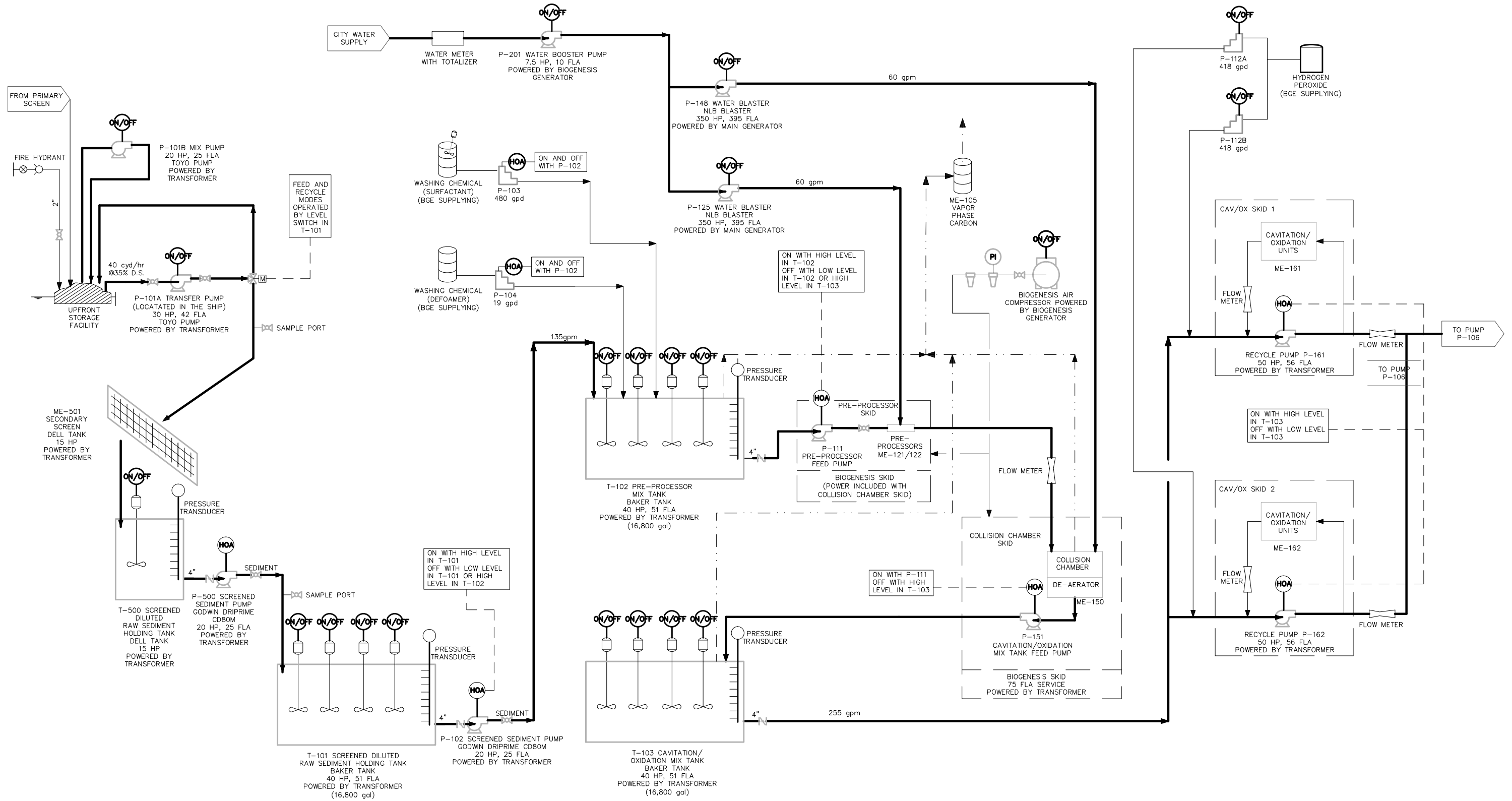

0	1/18/06	SM	AS BUILT
1	8/10/08	JGS	ADDED SECONDARY SCREEN
2	11/5/08	JGS	EDITORIAL
REV	DATE	BY	DESCRIPTION

SCALE
NTS

DESIGNED	S. MANDAVA	01-09-06
DRAWN	S. SOLLIE	01-09-06
CHECKED	J. SONTAG	01-09-06



BIOGENESIS
SEDIMENT DECONTAMINATION FACILITY
NJDOT OMR DEMONSTRATION PROJECT
KEASBEY, NEW JERSEY

FIGURE 3-3
PROCESS FLOW DIAGRAM

SHEET
1 OF 4

FILE: Figure 2-4 Process Flow Diagram Sheet 1 Revised.dwg

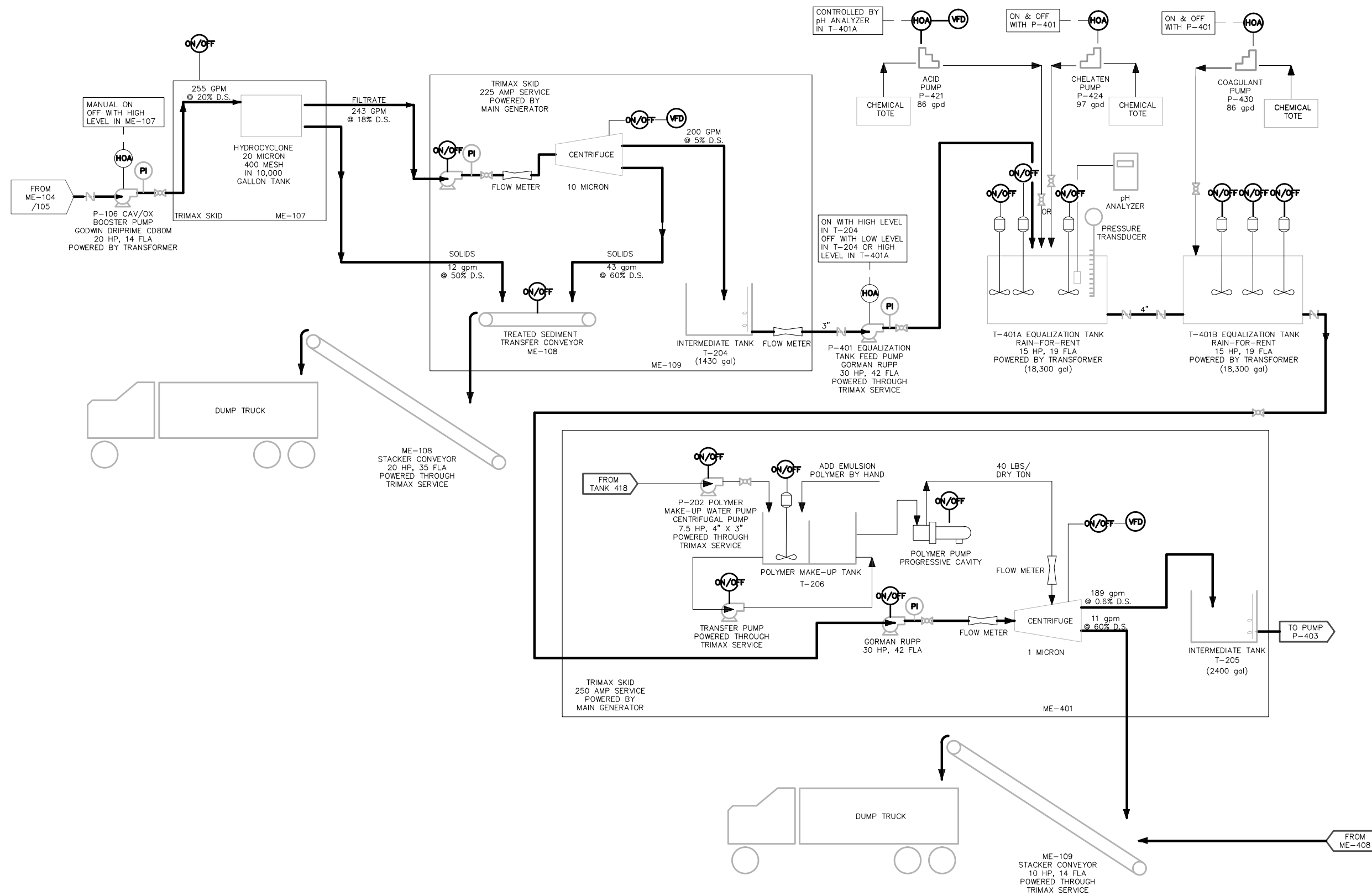

0	1/18/06	CDD	AS BUILT
1	8/10/08	JGS	ADDED ME NUMBERS TO CONVEYORS
2	11/5/09	JGS	EDITORIAL
REV	DATE	BY	DESCRIPTION

SCALE	DESIGNED	C. DURRANT	01-09-06
NTS	DRAWN	S. SOLLIE	01-09-06
	CHECKED	J. SONTAG	11-05-09



BIOGENESIS
 SEDIMENT DECONTAMINATION FACILITY
 NJDOT OMR DEMONSTRATION PROJECT
 KEASBEY, NEW JERSEY

FIGURE 3-3
 PROCESS FLOW DIAGRAM

SHEET
 2 OF 4

FILE: Figure 2-4 Process Flow Diagram Sheet 2 Revised.dwg

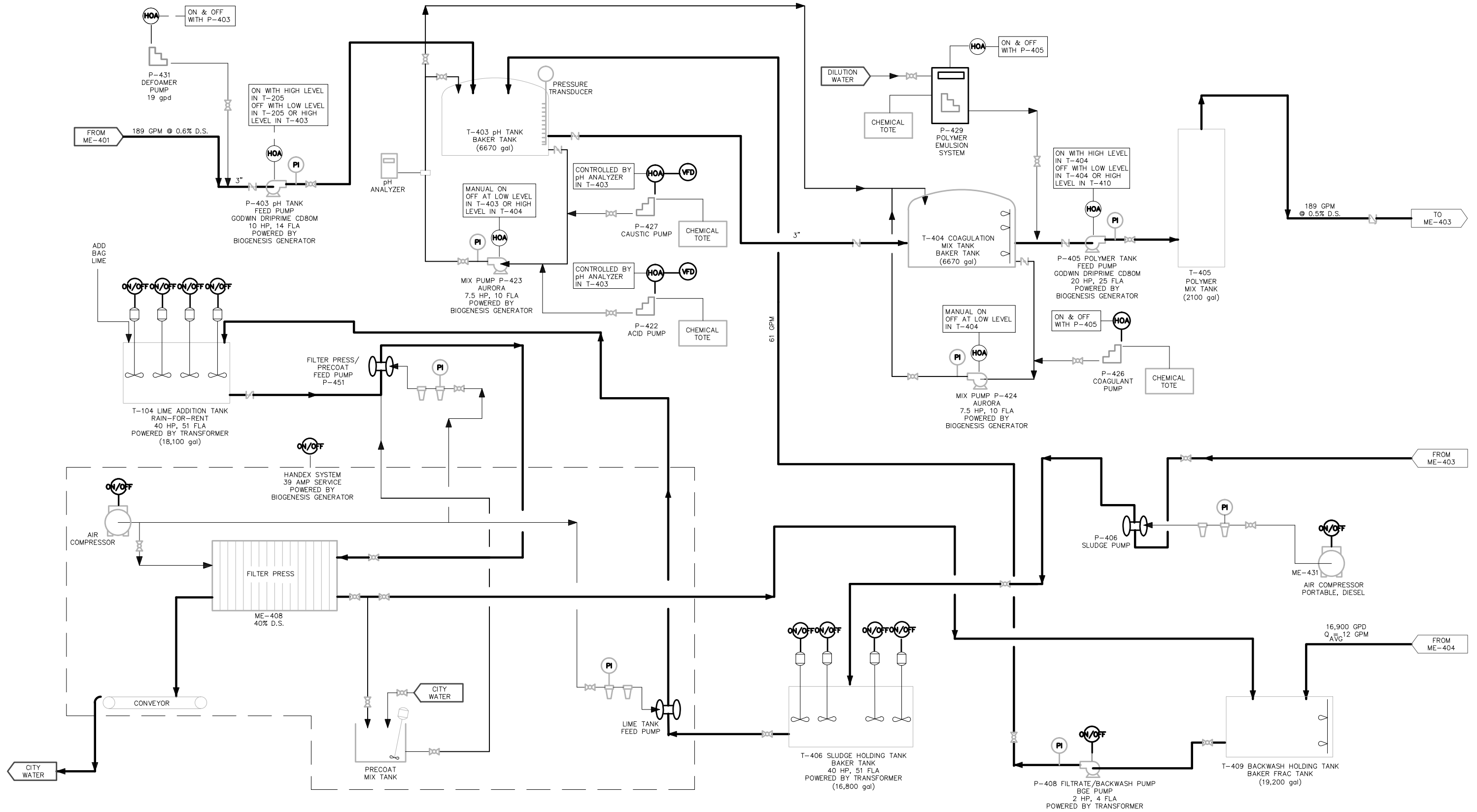

0	1/18/06	CDD	AS BUILT
1	8/10/08	JGS	REMOVED DUMPSTER UNDER FILTER PRESS
1	11/5/09	JGS	EDITORIAL
REV	DATE	BY	DESCRIPTION

SCALE
NTS

DESIGNED C. DURRANT 01-09-06
DRAWN S. SOLLIE 01-09-06
CHECKED J. SONTAG 11-05-09



BIOGENESIS
SEDIMENT DECONTAMINATION FACILITY
NJDOT OMR DEMONSTRATION PROJECT
KEASBEY, NEW JERSEY

FIGURE 3-3
PROCESS FLOW DIAGRAM

SHEET
3 OF 4

FILE: Figure 2-4 Process Flow Diagram Sheet 3.dwg

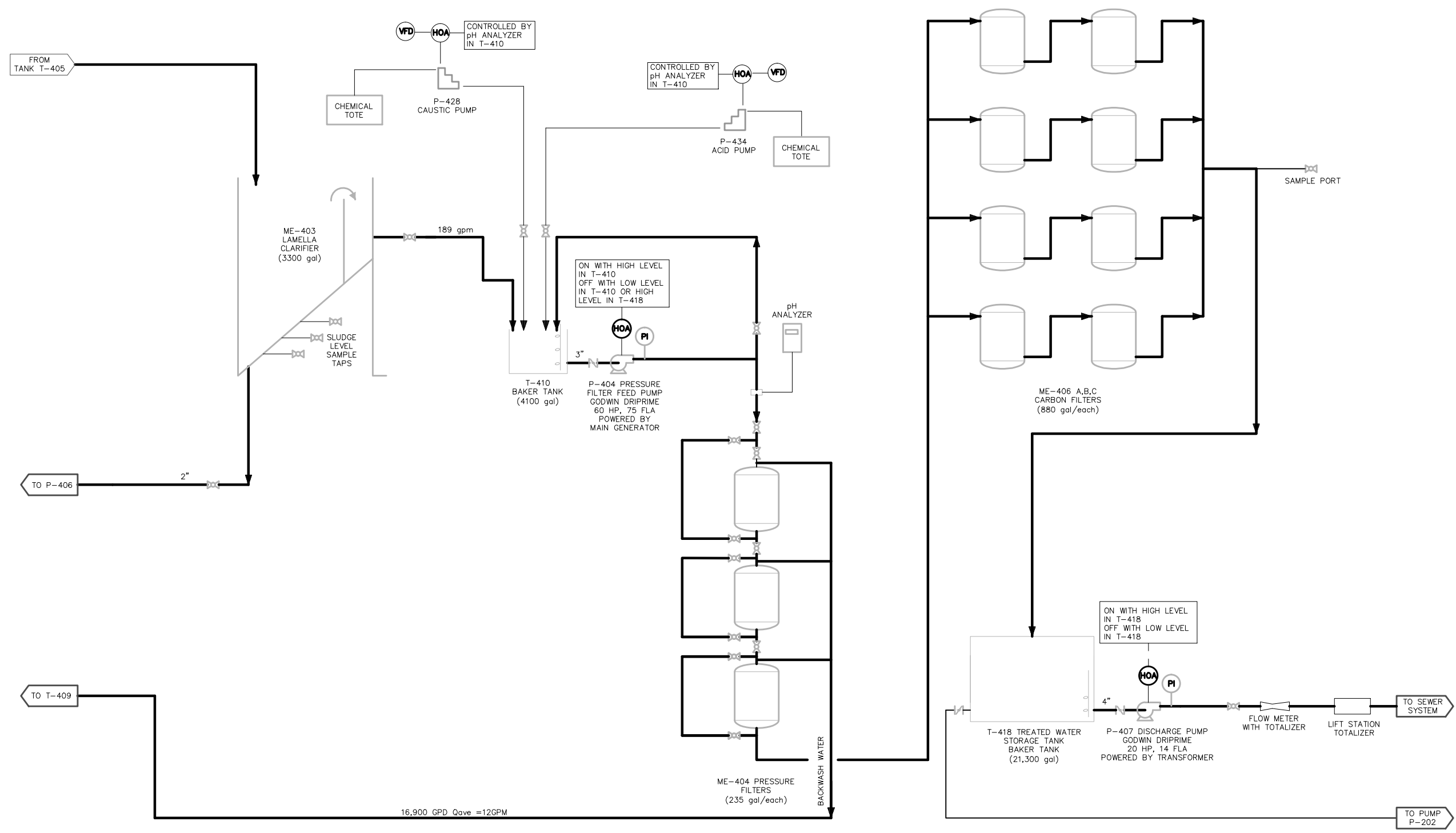

0	1/18/06	CDD	AS BUILT
1	11/5/09	JGS	EDITORIAL
REV	DATE	BY	DESCRIPTION

SCALE	DESIGNED	C. DURRANT	01-09-06
NTS	DRAWN	S. SOLLIE	01-09-06
	CHECKED	J. SONTAG	01-09-06



BIOGENESIS
 SEDIMENT DECONTAMINATION FACILITY
 NJDOT OMR DEMONSTRATION PROJECT
 KEASBEY, NEW JERSEY

FIGURE 3-3
 PROCESS FLOW DIAGRAM

FILE: Figure 2-4 Process Flow Diagram Sheet 4.dwg

were set to turn on when Tank 102 was filling. The residence time of the sediment in Tank 102 was over one hour to allow for thorough mixing.

- **Preprocessor** – There were two preprocessor heads installed on the BioGenesis™ Preprocessor skid. Each head was sized by BioGenesis to handle the full flow. The BioGenesis™ Preprocessor skid operated using one head at a time. High-pressure water was supplied to the heads by a dedicated 350 hp water blaster pump at 10,000 psi.
- **Collision Chamber** – The BioGenesis™ Collision Chamber was designed and constructed with two operating heads each capable of treating the full flow. One head was used at a time. The collision chamber was supplied with 10,000-psi water from a dedicated 350 horsepower water blaster pump. Treated sediment from the collision chamber was pumped into Tank 103 for mixing.
- **Cavitation/Oxidation Unit** – There were two BioGenesis™ Cavitation/Oxidation units operating in parallel to provide adequate treatment. Flow from Tank 103 was divided between the two cavitation/oxidation units and processed by adding a small amount of hydrogen peroxide and pumping the slurry through a restrictive orifice.
- **Hydrocyclones and Screens** – Flow from the cavitation/oxidation units was pumped to the hydrocyclone unit to start the dewatering process. First, the flow was pumped across a coarse, 100-mesh, scalping screen (150 microns). Underflow from the scalping screen was pumped through hydrocyclones and the underflow was dewatered on a 400-mesh screen (38 microns). Both screens discharged onto a conveyor belt and into a waiting dump truck.
- **Centrifuge 1** – Underflow from the 400-mesh screen was pumped into a decanter centrifuge operating at approximately 250 gpm. The solids that came out of the centrifuge ranged from 38 micron to 10 microns in size and had approximately 60 percent dry solids content. The solids from Centrifuge 1 were discharged onto the same conveyor belt as the hydrocyclones and screens.
- **Centrifuge 2** – This centrifuge received the decant water from the first centrifuge. Polymer was added to the slurry upstream of centrifuge 2 to enhance solids removal. The second centrifuge successfully removed solids from the wastewater down to less than one percent in the centrate. Solids recovered in the second centrifuge were discharged to a second conveyor belt and into a second waiting dump truck. The remaining decant water was pumped to the wastewater treatment system for final solids removal.
- **Wastewater Treatment System** – The centrate (water phase) from centrifuge 2 was pumped to the wastewater treatment system. The system was comprised of a chemical addition and mixing step, where a coagulant

(alum) and a flocculant (polymer) were added and mixed with the water. The water was then pumped to an inclined plate clarifier for settling and removal of any fine solids and dissolved solids that would come out of solution.

- **Filters** – Following chemical treatment of the wastewater, the water was pumped through a sand filter unit and carbon adsorption beds. Very fine particles that flowed through the clarifier were trapped in the sand filter beds and any remaining organic constituents in the water were adsorbed in the carbon beds.
- **Lift Station** – Wastewater was pumped from the treated water storage tank (T-418) to the lift station that served the facility. The sewage pumps in the lift station were upgraded to handle the flow from the demonstration project. Wastewater being discharged to the lift station was sampled on a daily and then weekly basis during operations to ensure compliance with MCUA wastewater discharge limitations.
- **Sludge Treatment** – Solids collected in the clarifier were pumped into a holding tank and the sludge was kept mixed until it was processed. The sludge was processed by pumping it into another mix tank where powdered lime was added and mixed into the wastewater. After lime addition, the slurry was pumped to the plate and frame filter press where the liquid was forced out of the solids using compressed air. The filtrate water was stored in Tank 409 with backwash water from the sand filters, and carbon filters.

Filtrate water was slowly pumped back into the wastewater stream from centrifuge 2 for treatment.

The cake solids were discharged onto a conveyor and collected with the solids coming off Centrifuge 2. Solids from the filter press averaged around 40% dry solids content.

- **Power Supply** – The Keasbey facility was not equipped with an adequate power supply for the demonstration project. The total connected load for the processing equipment was approximately 1,050 kilowatts (kW). Power was supplied to the process equipment and ancillary project facilities (office trailers, lights, etc.) using three separate power supplies; approximately 340 kW from the facility power supply, 640 kW from a fixed backup generator at the facility, and approximately 50 kW from a portable generator.

The layout of the process equipment for the demonstration project was developed based on the availability of space and other limitations of the site, and the size of

each piece of equipment. Presented in Figure 3-4 is the site layout, which shows the placement of the different components to the system.

3.3.3 Processed Dredged Material Storage Area

Processed dredged material was loaded in dump trucks and transported to the Processed Dredged Material Storage Area onsite where it was stockpiled pending offsite beneficial use. The Processed Dredged Material Storage Area was constructed in accordance with the facility AUD from the NJDEP. It consisted of a paved surface bounded on three sides with jersey barriers. The jersey barriers were used as push walls to stockpile the processed dredged material. Typical erosion and sedimentation controls (hay bales wrapped in filter fabric) were used to filter any surface water that drained from the stockpiled material and any precipitation that may have collected in the stockpile area.

3.4 Facility Construction

Waterfront facilities were constructed by the facility owner/operator to meet the requirements of the Waterfront Development Permits. Construction of the waterfront facilities began in the spring of 2005 and was completed in October 2005.

Construction of the demonstration facility was conducted under a design-build scenario. This means that some construction efforts began before all the design elements of the project were completed. Construction activities were conducted between August 30 and December 9, 2005 in an organized, sequential manner to ensure quality and enhance communication during work. The facility was constructed using national construction standards and skilled craft labor.

3.5 Sediment Sources

Sediment for the demonstration project was obtained from three sources, the Raritan River, the Lower Passaic River, and the Arthur Kill. Each location for dredging was pre-approved by the State of New Jersey.

The Raritan River was dredged adjacent to the site under an emergency-dredging permit to provide barge access to the offloading facility. Following construction of the facility and placement of the Upfront Storage Facility, it was determined that there was inadequate draft at the approach to the offloading facility to accommodate transport scows used for the dredging of the Lower Passaic River. In order to achieve a safe draft for the delivery of transport scows, dredging was conducted by Great Lakes Dock and Dredge Company under contract to BioGenesis.

Sediment from the Lower Passaic River was dredged during the Environmental Dredging Pilot Project conducted in the Lower Passaic River by the USEPA and NJDOT to evaluate dredge equipment performance and to study sediment re-suspension during environmental dredging. A total of 4,150 cy of sediment, as measured in-situ, was dredged during the pilot project and delivered to the BioGenesis demonstration Project. The sediment was stored in the Upfront Storage facility for the demonstration of the BioGenesisSM Sediment Decontamination Technology as well as the demonstration of other sediment decontamination technologies under the NJDOT/WRDA Sediment Decontamination Technology Demonstration Program.

At the time of the BioGenesis demonstration project, Donjon Marine Co., Inc. was dredging the Arthur Kill under contract to the USACE (Arthur Kill, Contract 2) as part of routine maintenance dredging of the NY/NJ Harbor. A portion of the sediment dredged from Area F under this contract was directed to the demonstration project with the help of the NJDOT and NJDEP.

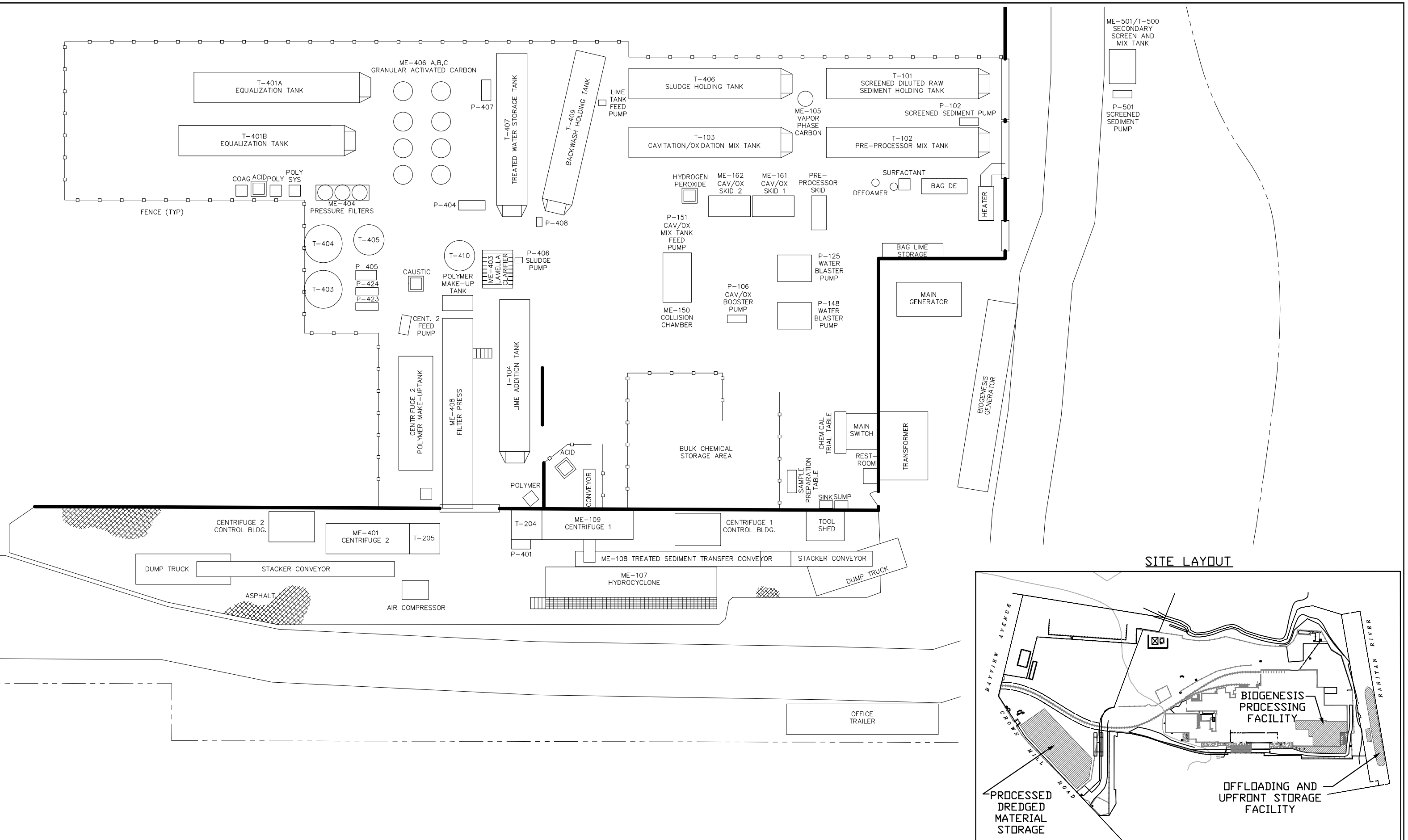

SITE LAYOUT

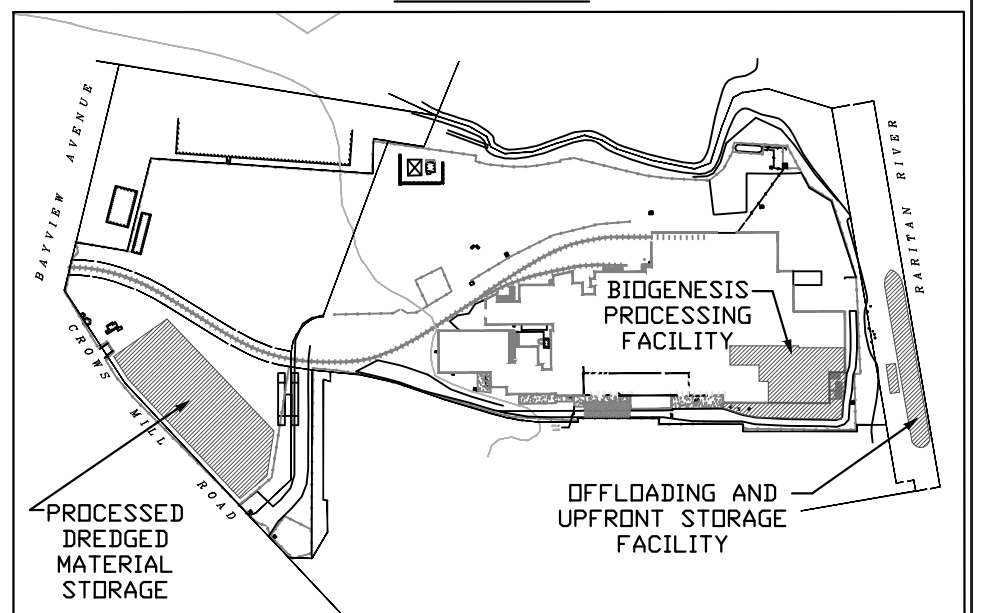

0	1/20/06	CDD	AS BUILT
1	8/10/08	JGS	ADDED OFFLOADING/STOCKPILE DETAIL
2	11/5/09	JGS	EDITORIAL
REV	DATE	BY	DESCRIPTION

SCALE	DESIGNED	CDD	9-13-05
NTS	DRAWN	CDD	9-13-05
	CHECKED	JGS	11-05-09



**BIOGENESIS
SEDIMENT DECONTAMINATION FACILITY
NJDOT OMR DEMONSTRATION PROJECT
KEASBEY, NEW JERSEY**

**FIGURE 3-4
BIOGENESIS DEMONSTRATION SITE LAYOUT**

FILE: Figure 2-5 Biogenesis Demonstration Site Layout.dwg

Presented in Table 3-2 are average concentrations of selected chemical constituents and the average grain size distribution in the untreated sediment from each of the three source areas. In general, the concentrations of organic contaminants were much higher in the Arthur Kill and Lower Passaic River sediment than in the Raritan River sediment, with the levels in the Lower Passaic River sediment consistently higher than those in the Arthur Kill sediment. The concentrations of several metals in the untreated sediment followed similar trends with a few exceptions. Arsenic concentrations were much higher in the Raritan River sediment, Mercury concentrations were the highest in the Arthur Kill sediment, and Nickel concentrations were consistent through all three sediment sources.

The grain size distribution data showed approximately 26 to 29% sand, 47 to 53% silt, and 18 to 21% clay in the Arthur Kill and Lower Passaic River sediment. The Raritan River sediment showed less sand (15%) and more clay (30%) on average as compared to the other two source areas.

The average total organic carbon (TOC) concentration in the untreated sediment was the highest in the Lower Passaic River sediment at 61,460 mg/kg, followed by 44,230 mg/kg in the sediment from the Arthur Kill and 24,796 mg/kg in the Raritan River sediment.

3.6 Sediment Volumes

The volumes of dredged material from each of the three area sources (Raritan River, Lower Passaic River, and the Arthur Kill) delivered to the project site were determined based on several factors including the quantity of material to be dredged at each location, the storage capacity of the Upfront Storage Facility, the daily processing rate of the sediment treatment system, and the amount of funding available to the project.

Table 3-2 Average Chemical Concentrations and Physical Characteristics of the Untreated Sediment

Selected Chemical Constituents	NJ RDCSRS ¹	Raritan River Sediment	Arthur Kill Sediment	Lower Passaic River Sediment
Total Organic Carbon (mg/kg)	-	24,796	44,230	61,460
Dioxins/Furans (pg/g)				
2,3,7,8-TCDD	-	3.2	52.7	651.4
TCDD/TCDF TEV	-	13.7	102.2	751.4
Total Polychlorinated Biphenyls (µg/kg)²	200	71.4	389.1	463.8
Polynuclear Aromatic Hydrocarbons (µg/kg)				
Anthracene	17,000,000	140	914	700
Benzo(a)anthracene	600	329	1,378	1,688
Benzo(a)pyrene	200	359	1,290	1,732
Benzo(b)fluoranthene	600	409	1,398	2,041
Chrysene	62,000	334	1,534	2,035
Dibenz(a,h)anthracene	200	53	235	316
Fluoranthene	2,300,000	487	2,389	3,047
Total PAHs	-	3,724	16,516	20,089
Metals (mg/kg)				
Arsenic	19	52.9	30.2	13.4
Cadmium	78	1.0	5.6	6.6
Total Chromium	-	66	177	191
Lead	400	141	267	376
Mercury	23	1.2	7.4	4.9
Nickel	1,600	46.2	48.5	50.0
Silver	390	1.3	4.5	6.4
Zinc	23,000	279	418	660
Grain Size Distribution				
Sand (> 0.075 mm)	-	15.5%	26.0%	28.8%
Silt (0.002 to 0.075 mm)	-	54.5%	46.8%	53.0%
Clay (<0.002 mm)	-	30.0%	21.2%	18.2%

¹ NJRDCSRS = New Jersey Residential Direct Contact Soil Remediation Standards, NJDEP, 2008

² Total Polychlorinated Biphenyls are a sum of the individual PCB congeners.

BOLD indicates concentrations above the NJRDCSRS.

The following volumes of dredged material, as measured in the barges, were delivered to the project, offloaded and stored in the Upfront Storage Facility:

- approximately 4,621 cy from the Raritan River,
- 5,602 cy from the Lower Passaic River, and
- 13,301 cy from the Arthur Kill.

Presented in Figure 3-5 is a graph illustrating the volumes of dredged material stored in the Upfront Storage Facility during the demonstration project. The total volume of dredged material in the Upfront Storage Facility at any point during the demonstration project depended on the delivery schedule of the untreated dredged material, the offloading efficiency, and the processing schedule. The maximum amount of dredged material stored in the Upfront Storage Facility throughout the demonstration project was approximately 17,185 cy. At the completion of the BioGenesisSM Sediment Decontamination Technology demonstration project there was approximately 11,038 cy of untreated dredged material remaining in the Upfront Storage Facility that required offloading and upland disposal as discussed in Section 3.10.3.

3.7 Sample Collection

Throughout the demonstration project, the project team collected and analyzed hundreds of samples. Sampling protocols were established prior to the start of work to determine the location and frequency to collect samples. A Quality Assurance Project Plan (QAPP) was written and submitted to the State and the laboratory for approval before any samples were collected. The QAPP contains detailed information about the expected level of quality control from the lab, reporting requirements, electronic data deliverables, and analytical methods. The QAPP contains details about sample acquisition and other laboratory requirements for the project. Presented in Table 3-3 is a summary of the sampling program and data quality objectives from the QAPP.

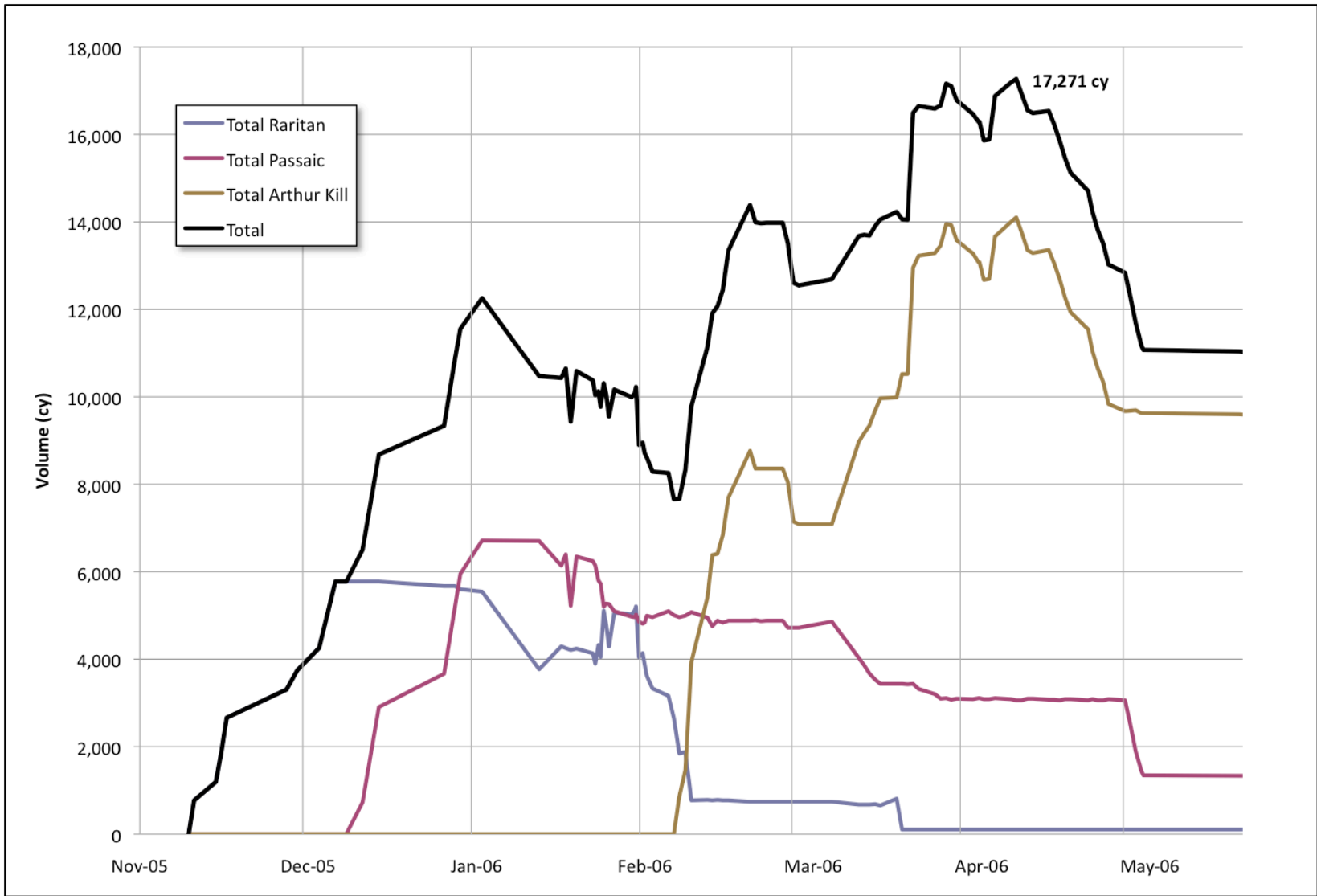

Figure 3-5 Total Dredged Material Stored in the Upfront Storage Facility

Table 3-3 Summary of Sampling Program and Data Quality Objectives

Sampling Program	Media	Location	Data Use	Sample Type	Parameters	Data Acquisition/Analytical Methods	Data Level	Frequency				
								Demonstration Testing	Full-Scale Operation			
Performance Verification	Incoming Sediment	Influent to secondary screening unit	Establish influent contaminant concentrations for performance evaluation; verify that influent concentrations are within the typical range	Composite of 4 grabs taken throughout the day (2 per shift equally spaced)	PAHs	SW-846 8270C or SW-846 8310	Definitive Level E	1 per day	1 per week			
					PCBs	SW-846 8082	Definitive Level E	1 per day	1 per week			
					Pesticides	SW-846 8081	Definitive Level E	1 per day	1 per week			
					Dioxins/Furans	SW-846 8290B (HR GC/MS)	Definitive Level E	1 per day	1 per week			
					PPL Metals (total)	SW-846 6010B/7471	Definitive Level E	1 per day	1 per week			
	Treated Sediment	Conveyor to treated sediment storage	Verify that the contaminant concentrations are less than or equal to the NJ residential soil cleanup standards	Composite of 4 grabs taken throughout the day (2 per shift equally spaced)	PAHs	SW-846 8270C or SW-846 8310	Definitive Level E	1 per day	1 per week			
					PCBs	SW-846 8082	Definitive Level E	1 per day	1 per week			
					Pesticides	SW-846 8081	Definitive Level E	1 per day	1 per week			
					Dioxins/Furans	SW-846 8290B (HR GC/MS)	Definitive Level E	1 per day	1 per week			
					PPL Metals (totals)	SW-846 6010B/7471	Definitive Level E	1 per day	1 per week			
Compliance Monitoring	Treated Wastewater	Treated water discharge pump effluent	Verify that the effluent is in compliance with the discharge limitations	Grab	TPH	SW-846 1664	Definitive Level D	1 per week	1 per week			
					Cyanide (Total)	EPA 335.4	Definitive Level D	1 per week	1 per week			
				Total VOCs	EPA 624	Definitive Level D	1 per week	1 per week				
				pH	EPA 150.1	Definitive Level D	1 per week	1 per week				
				Composite of 4 grabs taken throughout the day (2 per shift equally spaced)	SVOCs	EPA 625	Definitive Level D	1 per week	1 per week			
					Pesticides/PCBs	EPA 608	Definitive Level D	1 per week	1 per week			
					PPL Metals	EPA 200.7/245	Definitive Level D	1 per week	1 per week			
					BOD	EPA 405.1	Definitive Level D	1 per week	1 per week			
					COD	EPA 401.1	Definitive Level D	1 per week	1 per week			
					TSS	EPA 160.2	Definitive Level D	1 per week	1 per week			
				Dioxins	SW-846 8280A	Definitive Level D	1 per week	1 per week				
					Off-Gas Emissions	Ambient Air	Verify that emissions meet the permit limitations	Continuous and Grab	Total VOCs/SVOCs	Portable monitoring Equipment	Screening Level C	Periodic
				Continuous and Grab				PM-10, TSP	Portable monitoring Equipment	Screening Level C	Periodic	Periodic
				Sludge from Wastewater Treatment	Sludge conveyor	Determine if sludge is characteristic hazardous wastes	Composite of 4 discrete samples	TCLP SVOCs	SW-846 1311/8270B	Definitive Level D	1 per Week	1 per week
TCLP Metals	SW-846 1311/6010B/7471	Definitive Level D	1 per Week					1 per week				
TCLP Pest/Herb	SW-846 1311/8081	Definitive Level D	1 per Week					1 per week				
PCBs	SW-846 8082	Definitive Level D	1 per Week					1 per week				
GAC or other residuals	As needed	Identify parameters for disposal	Grab	As needed	As needed	Definitive Level D	As needed	As needed				

Notes:
 Screening Level C: Data collected in the field using portable meters
 Definitive Level D and E: Inorganic or organic data generated by a laboratory using standard or modified methods of analysis

Several types of samples were collected during the demonstration project. Raw sediment samples were collected after the dredged material was pumped from the Upfront Storage Facility to the treatment facility. Processed sediment was collected at the effluents from the solid/liquid separation step. Processed sediment was sampled in fractions (i.e. one sample per solid/liquid separation step) and as a total composite sample. Manufactured soil samples were collected following blending the decontaminated sediment into a product for beneficial use. Wastewater samples were collected prior to discharge of the treated wastewater to the lift station. Intermediate samples were collected throughout the process. All samples collected during the project were identified using the following nomenclature:

Location Identification – Sample Date – Sample Time

The Location Identification was used to identify where the sample was taken and whether it was a composite of several locations or an individual sample location. The sample Location Identifications used during the demonstration project are illustrated in Figure 3-6 and described in Table 3-4.

Provided in Appendix B are summary tables of the validated analytical results for all samples collected during the demonstration project. The data is organized with separate tables for each matrix and each group of analytes. The individual tables are organized by analyte and sample location on a specific day. Concentrations of analytes that were detected in the samples at concentrations above the laboratory's method detection limits are provided in the tables. Units of measurement are listed next to the analytes. Each sampling day had several samples taken from different parts of the treatment system.

3.8 Data Validation

Analytical data collected during the demonstration project was verified and qualified by MWH Americas, Inc. based on data evaluation parameters or quality control samples as explained in the laboratory standard operating procedures and

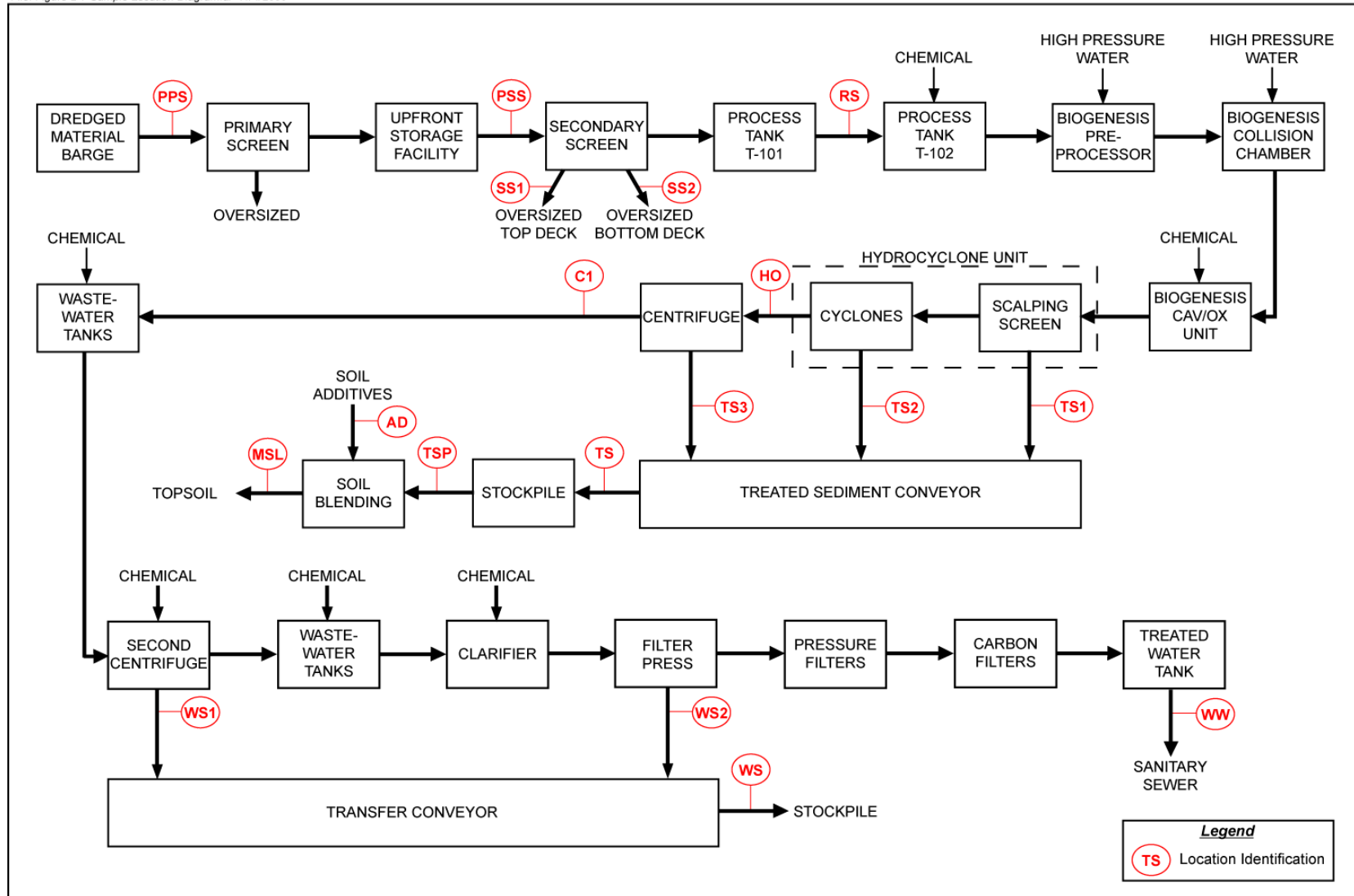

Figure 3-6 Sample Locations

Table 3-4 Sampling Location Identification Descriptions

Location Identification	Type	Matrix	Location Description
PPS	Single Location	Sediment	Raw sediment collected prior to processing through the primary screen
PSS	Single Location	Sediment	Raw sediment collected prior to processing through the secondary screen
SS1	Single Location	Solid	Screenings from the upper deck of the secondary screen
SS2	Single Location	Solid	Screenings from the lower deck of the secondary screen
RS	Single Location	Sediment	Raw sediment collected prior to the addition of washing chemicals
TS1	Single Location	Solid	Treated sediment – material from coarse screen (100 mesh)
TS2	Single Location	Solid	Treated sediment – material from hydrocyclones and fine screen (400 mesh)
HO	Single Location	Liquid	Overflow from the hydrocyclones
TS3	Single Location	Solid	Treated sediment – material from centrifuge 1
TS	Composite	Solid	Treated sediment – composite of material from coarse and fine screens, and centrifuge 1 (TS1, TS2, and TS3)
C1	Single Location	Liquid	Centrate from centrifuge 1
WS1	Single Location	Solid	Wastewater Treatment Sludge – material from centrifuge 2
WS2	Single Location	Solid	Wastewater Treatment Sludge – material from filter press
WS	Composite	Solid	Wastewater Treatment Sludge – composite of material from centrifuge 2 and filter press
TSP	Composite	Solid	Material from treated stockpile
AD	Composite	Solid	Additive for manufactured soil
MSL	Composite	Solid	Manufactured soil
WW	Composite	Liquid	Treated wastewater prior to discharge to lift station

the project QAPP. Presented in Appendix C is the Data Validation Report describing the results of the data validation and procedures used to validate the data. In summary, the usability of the data package was found to be 99.9% and the data are considered of sufficient quality to make informed decisions about the efficacy of the BioGenesisSM Sediment Decontamination Process demonstrated in Keasbey, New Jersey.

3.9 Air Monitoring

The BioGenesisSM Sediment Decontamination Process is an ambient temperature, water based process. There are no air emissions from the decontamination processing facilities. In accordance with the NJDEP air permit requirements, however, air monitoring was performed using portable, hand-held, real-time, direct reading instruments. In addition, air monitoring was conducted in accordance with the requirements of the project Health and Safety Plan (HASP). Levels of volatile and semi-volatile organic compounds (VOCs and SVOCs) were monitored as well as dust emissions. No reportable levels of either class of compounds were encountered.

3.10 Demobilization

3.10.1 Process Equipment and Processing Facility

Following the demonstration project all the process equipment was cleaned and demobilized from the Keasbey site. The warehouse facility was cleaned to pre-project conditions in accordance with the lease requirements. Demobilization of the process equipment and cleanout of the facility was conducted between May 8 and June 2, 2006.

3.10.2 Processed Dredged Material

Following the completion of the demonstration project BioGenesis submitted three AUD requests to the NJDEP for the beneficial use of the processed dredged material

stockpiled onsite in the Processed Dredged Material Storage Area. The processed material from the solid/liquid separation process step was segregated in the stockpile area from wastewater treatment solids. In addition, the processed material was segregated by source area. Upon approval from the NJDEP, two truckloads (about 40 cy) of processed dredged material from the Lower Passaic River was transported to, and stockpiled at, Bridgeport Harbor for testing under a separate USACE program and a beneficial use demonstration at Montclair State University (MSU) (see Section 3.11). The remainder of the processed dredged material and the wastewater treatment solids was loaded into trucks and transported offsite for beneficial use as fill material at the Prologis Port Reading Business Park site in Woodbridge, New Jersey in accordance with two AUDs issued by the NJDEP. A total of 465 truckloads were used to transport 11,302 tons of processed dredged material and wastewater treatment solids to the Prologis site between July 10 and October 16, 2006. An additional 105 truckloads were used to transport approximately 2,170 tons of processed dredged material from the Lower Passaic River to the Prologis site on December 19 and December 20, 2006.

3.10.3 Untreated Dredged Material

At the completion of the demonstration project, approximately 11,038 cy of untreated dredged material remained in the upfront storage system. This material could not be processed during the demonstration project due to schedule and budget constraints. Requests for the beneficial use of the untreated dredged material were included in the two AUD requests that BioGenesis submitted to the NJDEP for the processed dredged material. Upon approval of the AUDs, the untreated dredged material was offloaded from the Upfront Storage Facility into transport barges, and transported to CEDTI's facility in Claremont, New Jersey where it was offloaded and stabilized with cement. The stabilized dredged material was then loaded into trucks and transported to the Prologis site for beneficial use as fill material.

Offloading of the Upfront Storage Facility was conducted by pumping the untreated sediment to the transport barges. Once the level of dredged material in the cargo holds was too low to pump, the remaining material was mechanically removed from the Upfront Storage Facility into the transport barges. The offloading of the Upfront Storage Facility was conducted between July 12 and November 28, 2006. The Upfront Storage facility was then cleaned to its pre-use condition between October 24 and December 12, 2006. The Upfront Storage Facility was removed from the site on June 23, 2008.

3.11 Manufactured Soil Demonstration

In the fall and winter of 2008, a demonstration project was completed at Montclair State University with approximately 20 cy of the decontaminated sediment from the Lower Passaic River. The decontaminated sediment was blended with sand, organic matter, and clay using approximately 40% decontaminated sediment by weight. The manufactured topsoil has been used to create an interpretative walk outside of Mallory Hall at Montclair State University as part of an environmental management sediment sustainability demonstration project.

3.12 Demonstration Project Costs

An important goal of the BioGenesis demonstration project was to estimate commercial-scale processing costs. A breakdown of the costs incurred during the demonstration project is presented in Table 3-5. These costs are not representative of a permanent commercial-scale operation, but were used to develop the commercial-scale costs presented in Section 4 of this report. A number of factors impacted the costs during the demonstration project; including the temporary nature of the project, the use of rental equipment versus capitalizing equipment over a long period, the use of subcontractors to provide specific expertise instead of direct-hired labor, and the lack of online redundant equipment. In addition, significant costs were incurred for mobilization, construction, and demobilization of the facility.

Table 3-5 Full-Scale Demonstration Project Cost Summary

				Cost
Planning Activities				
- Design, Plans, Engineering				745,636
- Permitting				364,474
- Personnel Training				<u>197,811</u>
			Subtotal:	\$ 1,307,921
Construction				
- Labor				712,332
- Equipment				525,885
- Utilities				6,955
- Other Direct Costs/Expenses				299,857
- Site Lease				292,502
- Construction of Offloading/Screening Facilities				264,829
- Construction of Upfront Storage Facilities				270,158
- Dredge Approach Channel				<u>190,038</u>
			Subtotal:	\$ 2,562,556
Shakedown				
- Labor				122,569
- Equipment				32,421
- Other Direct Costs/Expenses				<u>34,847</u>
			Subtotal:	\$ 189,837
Operations				
	Processing	Cost/cy¹	Standby⁴	
- Labor	1,356,372	92.12	342,385	1,698,758
- Equipment	901,641	61.24	516,474	1,418,115
- Washing Chemicals	272,797	18.53	-	272,767
- Utilities	108,285	7.35	62,028	170,313
- Other Direct Costs/Exp.	327,910	22.27	187,832	515,742
- Site Lease	112,140	7.62	64,235	176,375
- Offloading/Screening	272,961	11.60 ²	-	272,961
- Disposal of Oversized	<u>84,659</u>	<u>8.28³</u>	<u>-</u>	<u>84,659</u>
	Subtotal:	\$ 229.01	\$ 1,172,954	\$ 4,609,719
				\$ 547,791
Analytical Services				
Upfront Storage Facility Cleanout				
- Labor				416,850
- Equipment				158,611
- Utilities				3,478
- Other Direct Costs/Expenses				104,536
- Site Lease				40,565
- Stevedoring				751,782
- Stabilization/Placement of Untreated Sediment				<u>714,919</u>
			Subtotal:	\$ 2,190,740

Table 3-5 Full-Scale Demonstration Project Cost Summary (continued)

	Cost
Demobilization	
- Labor	382,876
- Equipment	341,291
- Utilities	6,955
- Other Direct Costs/Expenses	117,569
- Site Lease	42,500
- Placement of Treated Sediment	<u>272,434</u>
Subtotal:	\$ 1,163,624
Final Report	<u>\$ 107,758</u>
TOTAL FULL-SCALE DEMONSTRATION PROJECT COSTS	\$ 12,679,947

¹ Average processing cost per cy for 14,724 cy processed during the demonstration project

² Offloaded 23,524 cy of dredged material

³ Oversized costs based on 10,233 cy for dredged material from the Raritan River and Lower Passaic River. Disposal of oversized from the Arthur Kill paid for by USACE under separate contract.

⁴ Standby costs were minimized by reducing workforce when practical. Standby costs averaged approximately \$178,925 per week.

4 DISCUSSION OF RESULTS

4.1 Production and Processing Rates

During the BioGenesisSM Sediment Decontamination Technology demonstration project, dredged material from each of the three sources (Raritan River, Lower Passaic River, and the Arthur Kill) was processed using multiple operating conditions to evaluate the performance of the BioGenesis process. The material processed in the facility was changed frequently (daily and sometimes several times a day) to allow time for analytical analysis of samples collected under different operating conditions from different sources. In addition, due to the capricious nature of the Upfront Storage Facility, the source of dredged material treated in the processing facility was changed frequently to maintain a balance of material within the cargo holds.

Presented in Figure 4-1 is a graph of the quantities of dredged material from each of the three sources processed during the BioGenesis demonstration project. A total of 14,724 cy of dredged material was processed through the BioGenesis facility during the demonstration project, 3,539 cy from the Raritan River, 2,655 cy from the Lower Passaic River, and 8,530 cy from the Arthur Kill. In addition, a total of 1,287 cy (259,960 gallons) of water was removed from the top of the cargo holds with dredged material from the Lower Passaic River and processed through the wastewater treatment portion of the BioGenesis sediment decontamination facility during five operational days between January 13 and January 25, 2006. This water was excess water from dredging activities that could not be discharged during dredging as well as some excess water added during offloading and screening operations. Samples were collected of the treated wastewater prior to discharge in accordance with the wastewater discharge permit.

As stated previously, the BioGenesis sediment facility was designed to achieve an average plant uptime (processing time) of 80%. This was evaluated during the demonstration project to provide design information for a permanent facility. At

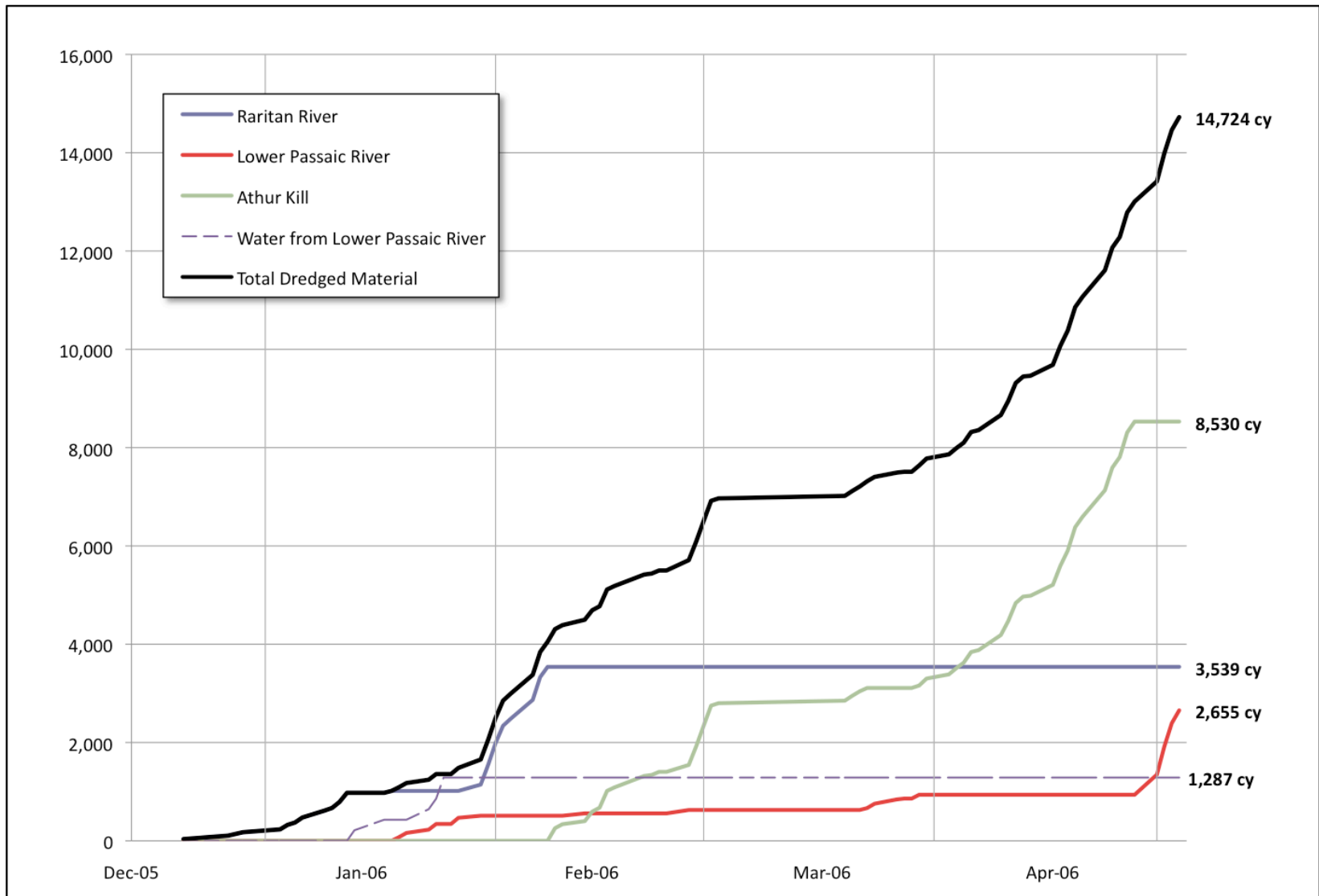

Figure 4-1 Dredged Material Processing

times during the project, the facility operated 24 hours per day, and involved two shifts. The plant uptime was evaluated by shift and for the entire day to be able to compare the performance of the two shifts. As illustrated in Figure 4-2 the daily facility uptime was around 40% during the beginning of the project and reached 80 to 90% at the end of the demonstration project. The day shift somewhat consistently outperformed the night shift. Factors affecting the processing time or facility uptime included initial startup problems, the use of rental equipment, the lack of inline spare equipment, and the location of the Treated Sediment Storage Facility with respect to the processing facility. While these issues were overcome by the end of the demonstration project, they will need to be addressed in the design of a permanent facility.

4.2 Equipment Performance

The BioGenesisSM Sediment Decontamination Process consisted of several individual components that, when combined, produced a treatment train for processing the sediment from the three sources. Equipment performance observations were made on an hourly and daily basis during processing, and data collection was divided into several operating zones within the process, i.e. the BioGenesis proprietary equipment; the offloading, screening, and storage steps; the dewatering and segregation steps; and the wastewater treatment steps.

As the project proceeded, several observations were noted regarding the effectiveness or ineffectiveness of parts of the process. Observations of the mechanical equipment and its operation, the general process train, management and labor support, and the facility that housed the treatment demonstration are discussed in the following subsections.

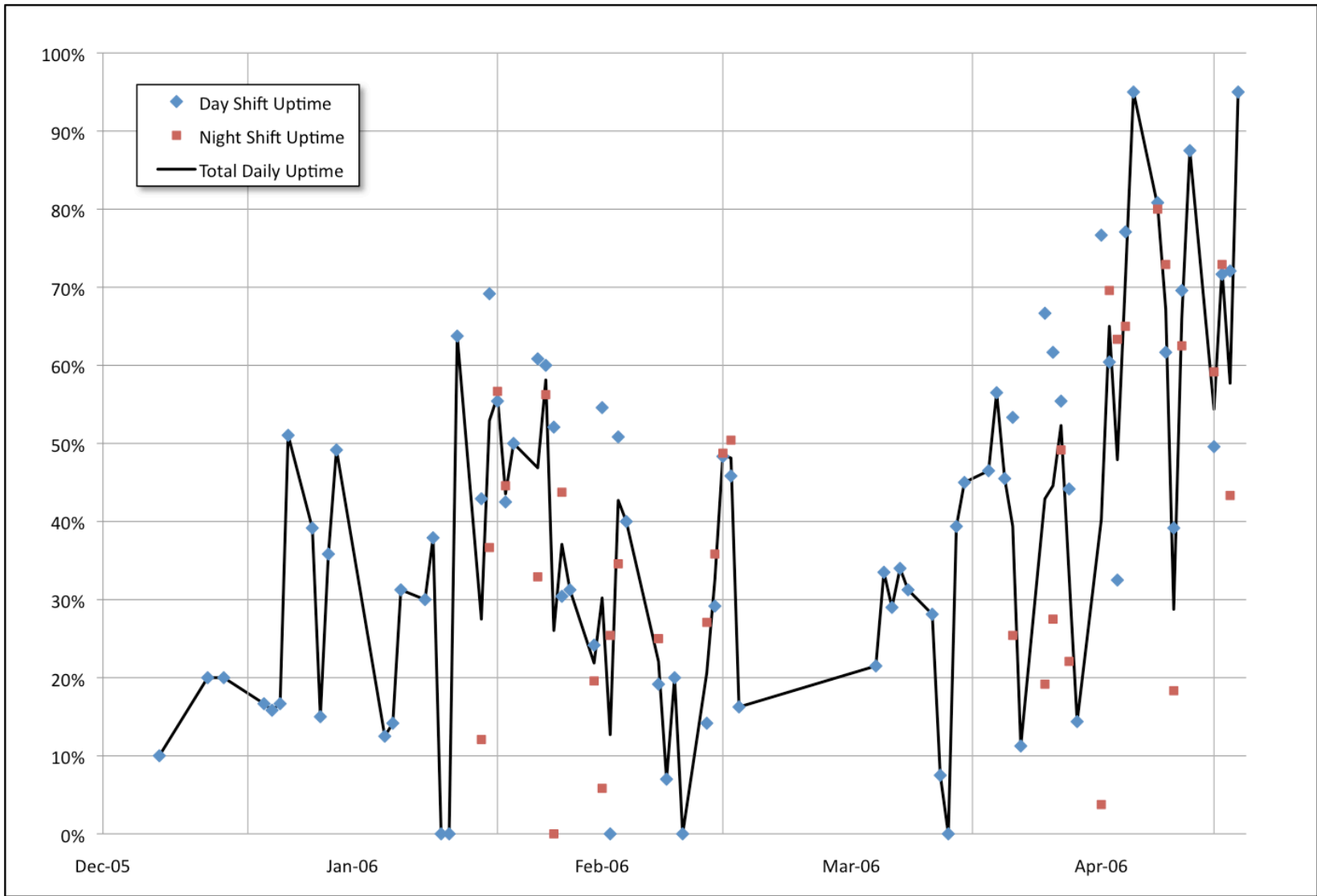

Figure 4-2 BioGenesis Facility Uptime

4.2.1 Barge Offloading and Screening

This operation consisted of a long-reach material handler with a clamshell bucket, a vibrating screen and transfer pumps to pump the sediment in to the holds of the Upfront Storage Facility.

The following observations were made for the performance of the offloading and screening operations.

- The clamshell material handler was effective and worked without any significant mechanical problems. Several sizes and types of material handlers were evaluated during the project. The material handler had to have a boom long enough to reach into the barge and collect the sediment, and large enough to feed the screening plant.
- The vibrating screen was assembled on-site on top of a flat-bottomed metal box to collect the sediment and water that passed through the screen. The vibrating screen consisted of three decks with different-sized screens ranging down to ¼ inches in size. The three decks were angled such that the screenings were shaken off into a roll-off box that could be loaded up and taken to the landfill. This screen had several mechanical problems over the time of operation, including broken screen decks, failed vibrating motors, and metal failure on various parts. Several holes and missing screen sections allowed material greater than ¼ inch to pass through the primary screening step requiring a secondary screener to be installed (see Section 4.2.4). Presented in Table 4-1 are the amounts of oversized material removed from the three sediment sources.

Table 4-1 Amount of Oversized Debris Removed

Sediment Source	Volume of Sediment Delivered to Project	Amount of Oversized Material Removed
Raritan River	4,621.2 cy	339.6 tons
Lower Passaic River	5,601.9 cy	118.4 tons
Arthur Kill	13,301.0 cy	3,488.1 tons

- Transfer of the screened material from the flat-bottomed metal box under the screening plant to the Upfront Storage Facility was problematic. Several transfer pumps were evaluated and tested during the project, and in the end, multiple pumps were needed to pump the screened sediment to the Upfront Storage Facility at an acceptable rate. A cone- or V-bottom tank would have facilitated pumping the screened sediment.

In general, offloading of the sediment transfer barges went smoothly once the correct pumps were installed and when the screen was operational. The offloading, screening, and transfer system to the Upfront Storage Facility was undersized for a full-scale system because it took several days to unload each dredged material scow. Long offloading times typically result in a surcharge by the dredging company, which would add to the cost for dredging and transport of the sediment. During the demonstration project a total of nine transfer scows were offloaded at the offloading facility from the Arthur Kill and Lower Passaic River dredging projects. Sediment from the approach channel in the Raritan River was primarily direct loaded from the dredge to the shaker screen. One barge was used intermittently in areas where the dredge could not reach the screen.

The scows offloaded were different sizes and held an average of 2,100 cy of dredged material each. The offloading rate was an average of approximately 470 cy per workday with a maximum of approximately 640 cy per workday. Presented in Table 4-2 is a summary of the scow offloading rates during the demonstration project.

Table 4-2 Summary of Barge Offloading Activities

Source/Barge	Volume	Offloading Rate	Days Onsite	Shifts to Offload ¹
Lower Passaic River				
Barge 1	2,424 cy	606 cy/shift	10.7 days ²	4 shifts
Barge 2	3,178 cy	636 cy/shift	16.9 days ²	5 shifts
Arthur Kill				
Barge 1	1,231 cy	410 cy/shift	3.1 days	3 shifts
Barge 2	2,487 cy	497 cy/shift	6.1 days	5 shifts
Barge 3	2,870 cy	574 cy/shift	21.7 days	5 shifts
Barge 4	1,659 cy	332 cy/shift	11.2 days	5 shifts
Barge 5	2,156 cy	431 cy/shift	3.7 days	5 shifts
Barge 6	1,525 cy	508 cy/shift	5.2 days	3 shifts
Barge 7	1,373 cy	275 cy/shift	12.9 days ²	3 shifts

¹ Shift is 10 hours, typically during the day, but in some cases night shifts were worked

² Barge was cleaned out prior to release. It typically took one shift to clean out the barges.

4.2.2 Upfront Storage Facility

As discussed previously, a bulk ore carrier from the Great Lakes was used as the Upfront Storage Facility during the demonstration project. It had six cargo holds of varying sizes and was moored adjacent to the project site. The maximum capacity of the facility was reached at approximately 17,185 cy during the demonstration project. The maximum capacity was dependant on the density of the sediment and the amount of water that was mixed in with the sediment during offloading. The volume of sediment stored in the Upfront Storage Facility was calculated using a spreadsheet formula that accounted for the different depths and geometry of each hold. Daily depth readings were taken in each hold and the results entered into the spreadsheet to keep a running tally of the volume of sediment stored.

The storage of sediment in a cargo ship was problematic for several reasons. The sediment in the Upfront Storage Facility constantly needed to be moved from hold to hold to balance the weight in the cargo ship to prevent structural damage. Presented in Figure 4-3 is a graph of the volume of dredged material stored in each cargo hold during the demonstration project illustrating the movement of sediment from hold to hold.

In addition, the deck height and the location of the Upfront Storage Facility relative to the mooring barges fluctuated with the tide and wind. This required flexible connections from the mooring barges to the ship and from the shore to the mooring barges for the electrical wiring and mechanical piping and hoses. These had to be relocated often resulting in process down times and extra labor costs. At times, the facility had a significant starboard list because it was partially grounded at low tide, which would cause the sediment to shift starboard exasperating the list.

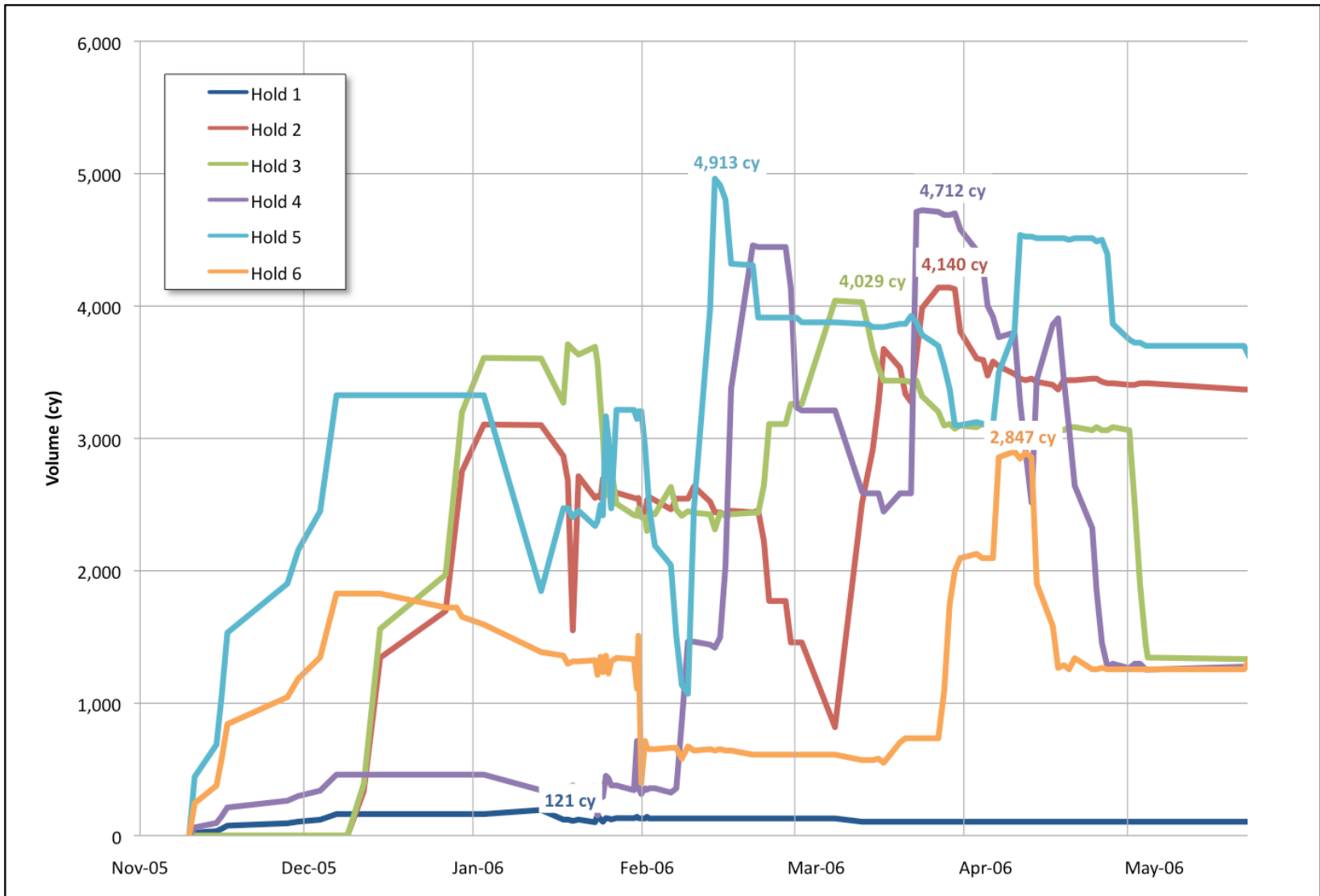

Figure 4-3 Total Dredged Material Stored in Each Hold of the Upfront Storage Facility

4.2.3 Dredged Material Transfer

Transfer of the dredged material from the Upfront Storage Facility to the BioGenesis processing facility was performed using large submersible pumps. Two pumps were used in the ship, one 20 Hp pump to mix the sediment in the cargo hold and one 30 Hp pump to pump from the Upfront Storage Facility to the treatment facility. The pumps were equipped with an agitator on the end of the impeller shaft that helped to stir up the dredged material as it was being pumped.

The dredged material was pumped through 4-inch diameter hoses and 4-inch diameter high-density polyethylene (HDPE) pipe a distance of over 350 feet. In general, the pumps worked well mixing the sediment and delivering the sediment to the process at more than 40 cy/hour at a slurry of 30 percent solids by weight. During the demonstration project, one of the submersible transfer pumps leaked water into the housing and shorted out the motor, which required a re-build to repair.

4.2.4 Secondary Screening

A secondary screen was installed on February 23, 2006 to remove rocks, organics, and debris greater than 1/4-inch that passed through broken decks and holes in the primary screen at the offloading facility. Prior to the installation of the secondary screen, the oversized material caused numerous blockages in the treatment system and resulted in pump damage. The secondary screen was a double-deck shaker screen with an integral tank for the underflow from the screen. The tank was equipped with a mixer that kept the screened dredged material agitated until it was transferred to Tank 101 using a centrifugal pump. The secondary screen was fed from the Upfront Storage System using the submersible transfer pumps in the Upfront Storage System. Originally, the screen was equipped with a 1/4-inch screen on top and a 1/16-inch on the bottom. These screens were changed to 3/32-inch and 1/32-inch toward the end of the demonstration project to remove a significant amount of organic material (grass, leaves, etc) as wells as debris and small stones

contained in the dredged material from the Lower Passaic River and Arthur Kill. Screenings dropped off the unit into a roll-off box that was hauled away for disposal.

The screen worked very well with no mechanical problems. An operator had to occasionally spray off the screen to keep it from blinding. The material collected in the roll-off box was mostly grass, leaves, other organic material, rocks, and detritus.

4.2.5 Mix Tanks

The mix tanks used for this project were rented portable tanks with integrated electric mixers. The tanks performed well and kept the solids from settling out during treatment. Prior to installation of the secondary screen, personnel repairing the level transducer in Tank 101 noticed that there was a significant amount of stringy material, rags, and other trash that had wrapped itself around the blades of the mixers in the tank. The blades were cleaned off, but this confirmed that the primary screen used for offloading was not capturing these materials (this was first observed in the collision chamber, see Section 4.2.8).

Two mixer motors failed during the demonstration project, one in Tank T-101 and one in Tank T-401a. Since both of these tanks were equipped with multiple mixers, the motors were not repaired during the project.

4.2.6 Chemical Addition

Chemical addition was performed using metering pumps. The metering pumps were positive-displacement, diaphragm-type pumps with adjustable speed and volume (stroke) controls. Some of the pumps were connected to a pH analyzer that metered acid and base into the process, depending on the predetermined pH needed. Some pumps were used to meter the proprietary BioGenesis chemicals into the process, some were used to meter chelating agent, one pump metered alum, and one pump metered polymer.

The chemical addition pumps were set at a pre-determined rate and left to turn on and off when the process equipment ran. Some adjustments were made when the

process changes required it. In a few instances, BioGenesis changed the chelating agent feed rate, or turned it off completely. BioGenesis also tried different chemical surfactants and differing feed rates to see the resulting effect on treatment. The polymer addition rate was adjusted based on visual clarity of the clarifier effluent, and the acid feed pumps were automatically driven based on the pH of the wastewater.

With the exception of two pumps, all chemical feed pumps worked as expected. The two pumps that did not work as expected were discovered to have a vacuum on the intake line to the chemical delivery point, causing delivery of more chemical than was needed with each stroke of the pump. This was remedied after the situation was discovered. One of the surfactant pumps was replaced with a larger pump that could handle more chemical at a higher viscosity.

4.2.7 BioGenesis™ Preprocessor

BioGenesis designed and supplied one preprocessor unit with two treatment heads (one operational and one standby). This piece of BioGenesis equipment performed as expected, with one unit being up and operational through the whole project.

The BioGenesis™ Preprocessor did experience some wear to the internal parts of the high-pressure injection ring. The 10,000 psi water injection nozzles had to be replaced daily due to this wear, and the nozzle wear eroded some of the metal inside the mounting ring that held the nozzles. The wear inside the preprocessor was caused by backpressure in the preprocessor head from the upstream restrictor plates in the collision chamber. Future operations will require an intermediate tank between the preprocessor and collision chamber, which will reduce the backpressure on the preprocessor and reduce wear to minimum levels.

4.2.8 BioGenesis™ Collision Chamber

The BioGenesis™ Collision Chamber skid had a high operational availability, and performed to expectations.

There were two noted issues with the operation of the BioGenesis™ Collision Chamber skid. The first was with the flow control orifices in the line feeding the collision chamber head. During processing of the Lower Passaic River dredged material, the flow control orifices were routinely plugged with organic material and trash. Once the secondary screener was installed and operational, this problem was remedied.

The second issue was with the discharge pump. Approximately halfway through the project the discharge pump started to operate at a slower rate and could not empty the collision chamber fast enough. The problem was caused by a puncture in one of the rubber liners in the pump, which was diagnosed and repaired. Adequate screening of the feed material would have prevented this problem.

4.2.9 BioGenesis™ Cavitation/Oxidation Unit

There were two BioGenesis™ Cavitation/Oxidation units in service during the demonstration project. Each unit performed mechanically as expected, but the peroxide feed to the units fluctuated and had to be adjusted over the course of the project to maintain a steady flow rate. The design of the units is such that the intake point for chemical addition is under vacuum pressure, which draws liquid through the chemical feed tubes at a higher rate than the metering pumps are set for. This was remedied during the project by installing a manual valve and visually recording the amount of chemical used each day from the supply tote. A minor design modification (such as injection of the hydrogen peroxide downstream of the pump) will resolve this problem going forward.

4.2.10 Hydrocyclone and Wet Screens

The hydrocyclones and wet screens were an integrated piece of equipment. This equipment was designed to remove sand and silt, which it did well. The unit had a high mechanical availability. Sediment slurry from the BioGenesis™ Cavitation/Oxidation units was pumped to this device and directed to a vibrating 100-mesh screen. This screen removed sand particles to about 150 microns in size and

dropped the sand onto a conveyor that transferred the solids to a waiting truck. A set of hydrocyclones with 1/4 inch apices were set over a second fine screen to capture silt-sized particles down to approximately 38 microns in size. The fine screen also discharged onto a conveyor and into the same truck as the sand.

The screens performed consistently and reliably. If anything the unit was oversized for our application, since only half of the screening capacity was used during the project.

4.2.11 Centrifuge 1

Centrifuge 1 was set up next to the hydrocyclones and wet screens and discharged onto the same conveyor as the screening unit. All three solids streams discharged into the same truck. The centrifuge operated without polymer and recovered solids from the underflow of the hydrocyclones and fine screen.

Centrifuge 1 captured solids down to 5 or 10 microns in size. The material removed was somewhat cohesive and very fine-grained. The granulometric distribution of the effluent from centrifuge 1 varied over a wide grain size, depending on the operating conditions of the day and the source of sediment being processed. Generally, the average solids content of the material entering the centrifuge was 4 to 5 percent.

Centrifuge 1 produced a significant vibration that was felt in the office trailer and within 50 feet of the unit in all directions. The unit (which was rented for the project) required bearing service, which was put off to the end of the project by the subcontractor supplying the centrifuge. Sensitive equipment or instruments had to be located a fair distance from the unit. The constant vibrations did create some fatigue to the personnel in the nearest office trailer. During commercial-scale operations, this problem would be remedied with proper mounting of the centrifuge, routine maintenance, and location relative to operations personnel.

4.2.12 Centrifuge 2

This centrifuge operated similarly to Centrifuge 1, except that it discharged into a different truck and that it was fed with polymer to help remove the fine particles. Centrifuge 2 operated well, to the point that the effluent centrate was clear water. The centrifuge operated without significant mechanical down time. One notable operational fact about using the centrifuges was that they took a long time to spin down and restart. If the slurry flow to the units was interrupted, they were shut off and could not be restarted until they came to a complete stop. In addition, if power to the centrifuges was interrupted (which occurred frequently since they were powered by a generator) they could not be restarted until they came to a complete stop. This resulted in several hours of down time, since the centrifuges were a critical component to solid/liquid separation in the process.

4.2.13 Clarifier

This clarifier was designed to flocculate and remove fine particles and some dissolved solids from the wastewater discharged out of Centrifuge 2. The clarifier operated by gravity and the feed water was pumped to the head of the unit after having a coagulant and polymer added. The clarifier sludge was drawn out of the unit and pumped to a holding tank prior to being stabilized and dewatered in a plate and frame filter press.

The clarifier worked as expected and typically produced a clear effluent. In some cases when Centrifuge 2 was not working well, the clarifier would receive a heavy solids load that resulted in the overflow of fine solids to the sand filters. Since the unit was a tall piece of equipment, it was hard to visually inspect the effluent regularly during operations and make adjustments. In order to maximize the efficiency of the clarifier, a set flow rate was chosen for the chemical feed pumps to the clarifier influent. The feed rate was occasionally adjusted when known changes were to occur, but typically, it was a uniform dosage. This likely resulted in the use of more coagulant and polymer than was necessary.

4.2.14 Sand Filters

The sand filters were designed to capture fine particles that were not removed in the clarifier. The filters were operated by pumping water into the top of a sand bed and collecting the filtered water from beneath the sand bed. The units were equipped with a manually operated backwash feature that allowed the operator to flush the beds in reverse, expanding the sand to release the trapped particles. The backwashed water was re-circulated through one of the other beds or pumped back into an upstream part of the process.

The filters did reduce the solids loading on the carbon filters. Following treatment of the free water decanted from the Lower Passaic River sediment in the Upfront Storage Facility, the filters became plugged to the point that they were reducing the flow rate to the carbon filters and would not effectively backwash. Upon inspection, it was noted that the filters were clogged with fine particles. These particles were suspended in the water decanted from the Lower Passaic River Sediment and were not removed in centrifuge 2 or the clarifier. The sand also had polymer coating the sand media as a result of an overdose of polymer feeding centrifuge 2 and/or the clarifier. The sand was removed from the filter vessels, placed in the storage area with the cake from the filter press and sludge from centrifuge 2, and replaced with clean sand and restarted. Sand replacement was only done once during the demonstration project.

4.2.15 Carbon Filters

The carbon filters were designed to remove any organic constituents dissolved or suspended in the wastewater. The filters worked very well. The effluent was typically clear and odor free. The carbon filters discharged into a storage tank and the contents of the tank were pumped to the existing sewer lift station on the site. As the project progressed, the carbon filters were backwashed and the solids on the filters were pumped back through the sand filters.

It was observed that the discharge from the carbon filters was occasionally a milky color with a sulfur odor. Since the system was shut down on Friday of each week and restarted Monday morning, it was thought that the carbon in the vessels might have acted as a growth medium for bacteria. The resulting odor and white color may have been a reaction between the bacteria and the low pH wastewater generated during restart. It is also thought that the white color may be a calcium precipitate created as the wastewater with dissolved lime filtered through the vessels in anaerobic conditions. Operators tried flushing some hypochlorite solution through the filters to help kill any bacteria, but the test may not have used a strong enough solution to remedy the problem. The wastewater cleared up temporarily with the addition of hypochlorite, but the odor and color eventually returned. The color/odor did not affect the performance of the system.

4.2.16 Wastewater Lift Station

The wastewater lift station, which pumped the wastewater from the project and the site to the POTW, was hydraulically upgraded at the beginning of the project to handle the anticipated flows from the BioGenesis facility. The lift station housed a flow totalizer and flow meter that were used to record the discharge rates needed to prepare the monthly reports to the POTW.

The upgraded pumps in the lift station performed well, with no mechanical problems.

4.2.17 Piping

The primary piping material used on the project was HDPE pipe. This material was selected because of its high chemical resistance and high abrasion resistance. The HDPE pipe was fusion welded together on site and connected to the pumps and equipment using flanged ends. Other piping used on site included polyvinyl chloride (PVC) and galvanized steel pipe. Flexible hoses were used in place of piping in several areas within the plant.

The piping performed well with no examples of failure by erosion or over-pressurization. After the system was taken apart, the HDPE piping was inspected for wear. Very little evidence of wear was noted, with only minimal wear being observed in the bends and elbows that experienced scouring by the sand and grit in the sediment. The straight piping runs had very little noticeable wear and only in high velocity zones. The hose used for the project showed very little evidence of visible scouring.

4.2.18 Pumps

There were several pumps installed in the system to transfer water and sediment slurry. Each pump was sized for a particular flow rate and head loss. Selection and use of pumps on the project was a dynamic process that involved the replacement or change-out of several pumps to address pump availability, changing project conditions, capacity, re-piping, process changes, and pump failure.

Overall, the pumps were reliable and worked well. After the system was taken out of service, the pumps were checked for wear and damage. Most of the pumps were not affected by the operation, particularly the ones designed for abrasive environments (i.e., pumps with rubber lined volutes and impellers) and the ones downstream of the centrifuges. The centrifugal pumps that were not rubber lined and moved the raw sediment did show signs of abrasion and wear.

Following operations, several of the rental centrifugal pumps required repairs. These pumps were rebuilt (new impellers and in some cases, new volutes) when they were returned to the rental company. The pumps with the most damage were located upfront in the process and pumped slurries with the highest concentration of solids. Noticeable wear occurred in the transfer pump between the secondary screener and tank T-101 and the transfer pump between T-101 and T-102. All slurry pumps in the future should have rubber linings. Examples of the pump wear are illustrated in the photos contained in Appendix A.

4.2.19 Power Supply

The power supply for the demonstration project was provided through a permanent onsite power supply, a 910 kW backup diesel generator onsite, and a portable 160 kW generator. In the planning stages of the site work, the facility had sufficient power capacity for the demonstration project because the facility was empty and there was very little demand on the existing power supply. Prior to construction, however, several tenants moved into the site and reduced the available power. Instead of installing a new service to the facility for a temporary project, it was decided that the two available generators would supplement the site power.

The use of two generators to power the processing equipment was problematic because service or repairs on either generator would shutdown a part of the process. Since the process had no redundant or backup components, a shut down of one of these units would result in the entire system being shut down. On several occasions, the larger generator was down for a day or more while repairs were being made.

4.2.20 Processed Dredged Material Transfer and Storage

The processed dredged material was loaded in dump trucks and transported to the Processed Dredged Material Storage Area onsite where it was stockpiled pending offsite beneficial use. As discussed previously, the Processed Dredged Material Storage Area consisted of a paved surface bounded on three sides with jersey barriers and erosion and sedimentation controls.

The Processed Dredged Material Storage area performed satisfactorily during the demonstration project. The use of dump trucks to transfer the treated dredge material to the area was problematic, however. Each time a dump truck was full, the process was stopped and the truck driven to the Processed Dredged Material Storage Area, dumped, and returned to the process area. Toward the end of the demonstration project, a second dump truck and/or a front end loader was used to minimize the interruption in operations.

4.3 Analytical Results

4.3.1 Raritan River Sediment

A total of 3,539 cy of dredged material from the Raritan River was processed through the BioGenesis sediment decontamination facility on 20 operating days between December 21, 2005 and February 8, 2006. During each operating day, samples were collected of the untreated sediment (sample location RS), the treated sediment (sample location TS), and the wastewater treatment sludge (sample location WS) in accordance with the QAPP. The analytical results of these samples were used to evaluate the operating performance of the system and to adjust the operational parameters.

At the beginning of operations, dredged material from the Raritan River was processed through the facility to shakedown the system and workout any mechanical problems. From January 3 through January 5, 2006 the system was operated in a consistent manner, i.e. similar process flow, similar water pressures in the preprocessor and in the collision chamber, and similar doses of washing chemicals. The average system uptime during this initial operating period was 25%. Presented in Table 4-3 is a summary of the average chemical concentrations in the samples collected during this operational period.

Presented in Figure 4-4 are graphical representations of the analytical results for select metals (arsenic, lead and mercury) of samples collected during this time. The bars on the graphs represent the average concentrations; the maximum and minimum concentrations are represented with the limit lines on each bar. In addition, statistical analysis of the data is provided in the table next to the graphs.

The concentrations of lead and mercury were below the NJRDCSRS for the untreated sediment (sample location RS), as well as the treated sediment (sample location TS) and the wastewater treatment solids (sample location WS). The concentration of arsenic, however, in the untreated dredged material (sample location RS) was an

Table 4-3 Average Chemical Concentrations in Samples Collected During Optimum Operating Conditions without Chelant – Raritan River Sediment

Operational Dates:	1/3/2006, 1/4/2006, 1/5/2006 & 1/6/2006		
Sample Location:	RS	TS	WS
Metals/SW6010B (mg/kg)			
Arsenic	37.6	27.2	59.9
Barium	123	87	138
Cadmium	0.8	0.47	1.1
Chromium, Total	46.0	25.7	82.4
Lead	99	57.8	179
Mercury (SW7471A)	1.0	0.8	1.9
Nickel	35.7	31.1	54.4
Selenium	3.7	1.6	4.5
Silver	0.8	0.5	1.5
Zinc	202	129	326
PAHs/SW8270C-SIM (ug/kg)			
Acenaphthene	43	32	13.2
Acenaphthylene	49	48	21.0
Anthracene	120	122	45.3
Benzo(a)anthracene	280	235	68.3
Benzo(a)pyrene	330	285	60.5
Benzo(b)fluoranthene	423	303	78.8
Benzo(g,h,i)perylene	181	144	39.3
Benzo(k)fluoranthene	78	127	28.9
Chrysene	268	250	65.3
Dibenz(a,h)anthracene	43	36	10.0
Fluoranthene	458	410	132
Fluorene	54	43	21.8
Indeno(1,2,3-c,d)Pyrene	155	124	31.5
Naphthalene	69	63	24.0
Phenanthrene	320	289	78.3
Pyrene	500	430	151
Pesticides/SW80801A (ug/kg)			
Dieldrin	9.7	3.6	9.1
p,p'-DDD	5.0	5.1	6.4
p,p'-DDE	6.5	6.6	9.2
p,p'-DDT	10.1	9.1	10.2
PCBs/SW8082 (ug/kg)			
Total PCB Congeners	44.3	49.2	55.0
Dioxins/Furans (pg/g)			
2,3,7,8-TCDD	1.7	0.6	1.6
TEV (using 2005 WHO TEFs)	24.7	8.8	18.6

Note: Where analytes were reported as ND, the average concentration was calculated using ½ of the reporting limit. In calculating the TEVs, ½ of the reporting limit was used for all analytes reported as ND or below the reporting limit.

average of 37.6 mg/kg and in the treated material (sample location TS) was an average of 27.2 mg/kg. The p value for the arsenic data in the TS samples compared to the RS samples indicates that even though the change in concentration is small, it is statistically significant (p value less than 0.05). In addition, the p value for the mercury data in the TS samples compared to the RS samples shows no statistically significant change in concentrations (p value greater than 0.05). No chelant was added to the process flow during this period.

As analytical results became available during the demonstration project, the operating parameters of the Bio-GenesisSM Sediment Decontamination Process were adjusted to improve system performance. Based on the analytical results for the Rari-

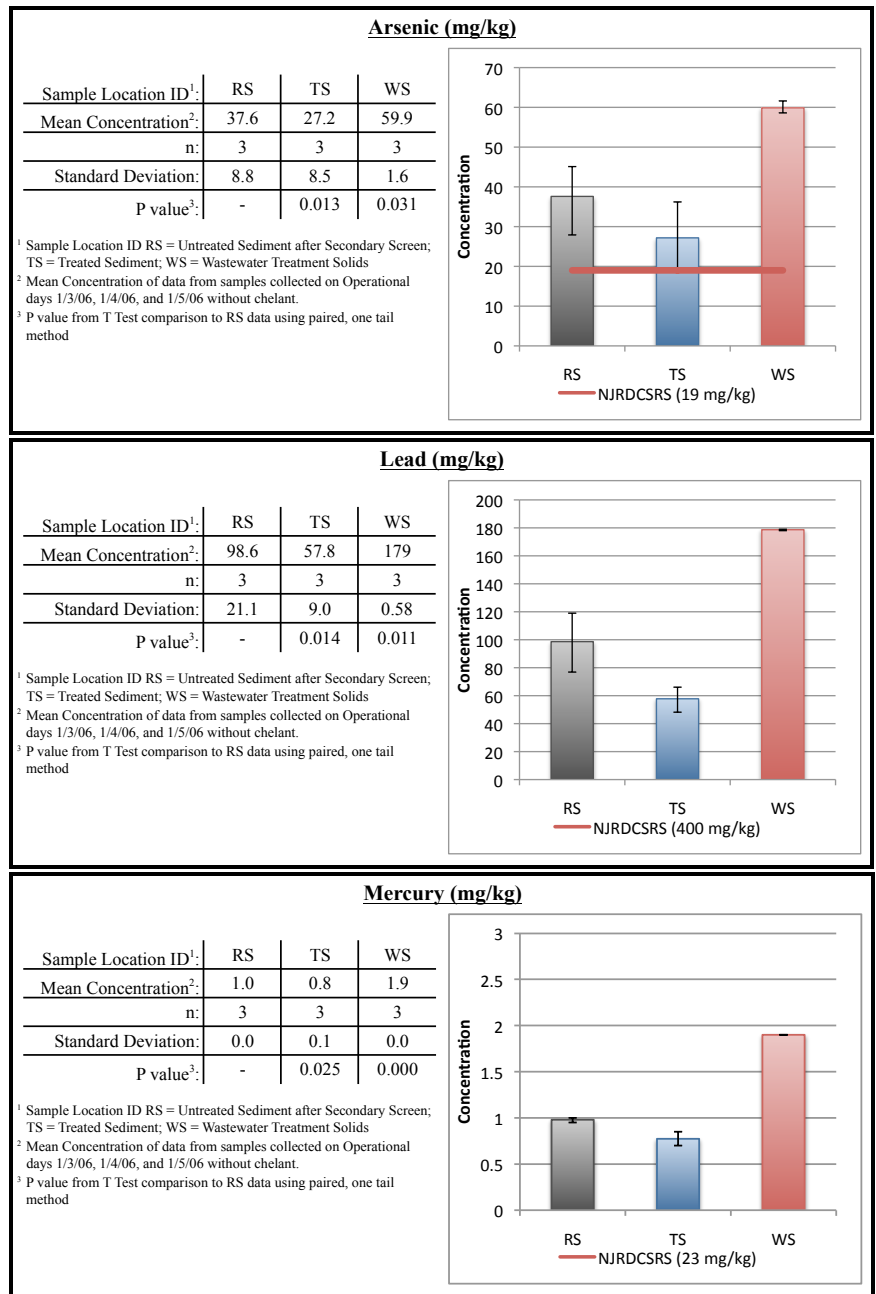
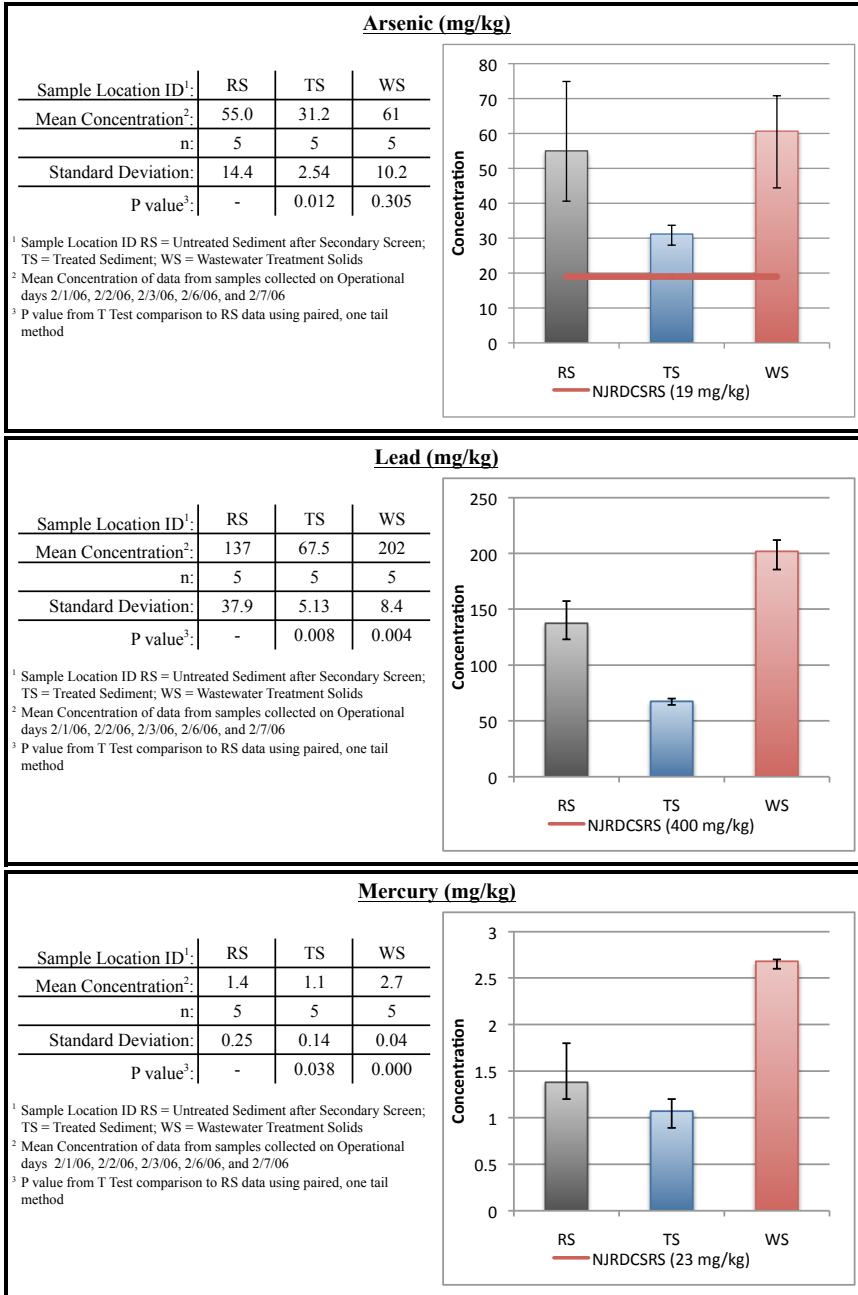

Figure 4-4 Analytical Results for Metals without Chelant – Raritan River Sediment

tan River sediment from early January 2006, a chelant was added to the process flow to try to improve the removal of arsenic, and the system was operated again in a consistent manner from February 1 through 7, 2006. During this time, the facility had an improved system uptime (average of 56%). Presented in Figure 4-5 are

graphical representations of the analytical results for select metals for the samples collected on these days. A summary of the average metal concentrations in the sediment samples is presented in Table 4-4. Again, the concentrations of lead and



mercury were below the NJRDCSRS in the untreated sediment samples (sample location RS) as well as the treated sediment samples (sample location TS) and the samples of the wastewater treatment solids (sample location WS). The p value for the lead and mercury data in the TS samples compared to the RS samples shows a statistically significant change in concentrations (p value less than 0.05).

A comparison of the reduction in mean concentrations of metals between the RS and TS samples with and without chelant indicates that the chelant had an effect on the removal of most metals. A comparison of the arsenic data, however, shows only a

slight improvement in the removal of arsenic with the addition of chelant. This could be explained by a naturally occurring source of arsenic present within the

Table 4-4 Average Chemical Concentrations in Samples Collected During Optimum Operating Conditions with Chelant – Raritan River Sediment

Operational Dates:	2/1/2006, 2/2/2006, 2/3/2006, 2/6/2006 & 12/7/2006		
Sample Location:	RS	TS	WS
Metals/SW6010B (mg/kg)			
Arsenic	55.0	31.2	60.7
Barium	141	97.2	130
Cadmium	1.4	0.8	2.4
Chromium, Total	63.0	28.8	92.4
Lead	137	67.5	202
Mercury (SW7471A)	1.4	1.1	2.7
Nickel	43.0	25.5	45.6
Selenium	4.0	2.0	4.1
Silver	1.3	0.6	2.1
Zinc	260	128	427

Note: Where analytes were reported as ND, the average concentration was calculated using ½ of the reporting limit. In calculating the TEVs, ½ of the reporting limit was used for all analytes reported as ND or below the reporting limit.

mineral matrix (i.e., within the soil particle itself) that could not be removed from the surface of the particle or chelated away from the sediment particle. A review of historical data for the region shows elevated levels of naturally occurring arsenic. Research sponsored by the NJDEP, Division of Science, Research, and Technology, documents the ambient levels of total arsenic in New Jersey coastal plain soils range from 13 to 131 mg/kg, with a median of 30 mg/kg (NJDEP, 2001). These values are consistent with the arsenic levels in the sediments in the Raritan River sediments and support the theory that the arsenic was bound in the mineral matrix and is thus un-extractable.

At the time of the demonstration project the concentrations of PAHs in the sediment from the Raritan River were below the NJRDCSRS, however, the current standards have been lowered and benzo(a)pyrene concentrations in the untreated sediment are elevated above the NJRDCSRS. Presented in Figure 4-6 is a graphical representation of the analytical results for select PAHs (benzo(a)pyrene, benzo(a)anthracene, and dibenz(a,h)anthracene) for samples collected during operations from January 3 through January 6, 2006. The concentrations of

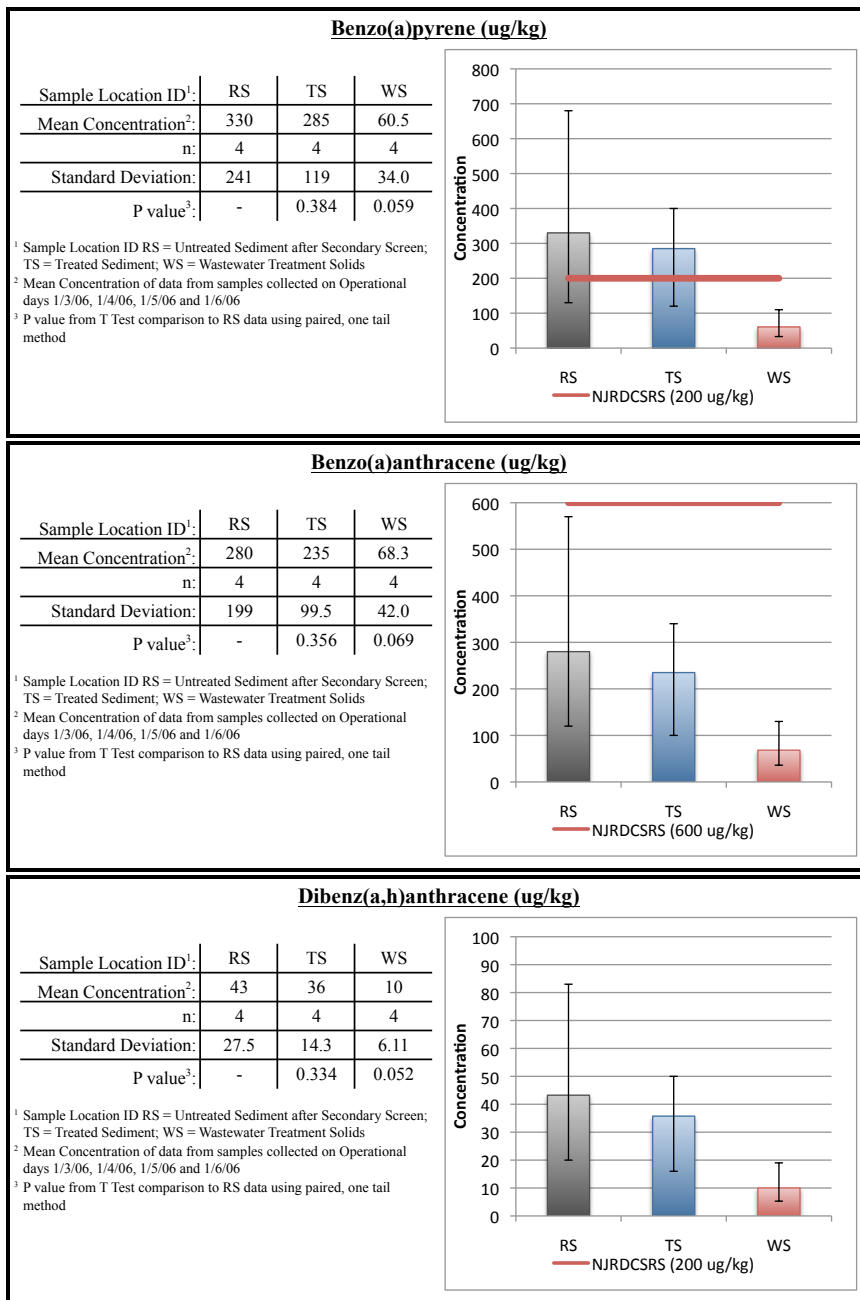

Figure 4-6 Analytical Results for PAHs – Raritan River Sediment

expected since the wastewater treatment solids are the fines that were not captured in the solid/liquid separation step, are much finer-grained particles than the decontaminated sediment, and therefore have a much larger surface area to volume ratio. Assuming the PAHs are adsorbed to the surface of the particles one would expect the concentration to be higher in these solids as was observed with the metals results.

benzo(a)anthracene, and dibenz(a,h)anthracene were below the current NJRDCSRS for most of the samples of the untreated sediment. While it appears there is a slight reduction in PAH concentrations observed between the untreated sample (RS) and the decontaminated sediment sample (TS) the difference in mean concentrations is not statistically significant (p values are greater than 0.05).

One observation that can be made is that the concentrations of PAHs in the wastewater treatment solids (sample location WS) are lower than the concentrations in the untreated sediment and the decontaminated sediment. This is not

PCBs, dioxins, and furans were also below the NJRDCSRS in the sediment from the

Raritan River, however, in accordance with the QAPP, samples collected during operations were analyzed for these compounds. Presented in Figure 4-7 are graphical representations of the analytical results for select total PCBs, 2,3,7,8-tetrachlorodibenzo-p-dioxin (2,3,7,8-TCDD), and dioxin toxicity equivalency values (Dioxin TEVs) for samples collected during operations from January 3 through January 6, 2006. Note that the Dioxin TEVs were calculated using the 2005 World Health Organization (WHO) Toxicity Equivalency Factors (TEFs) using ½ of the reporting limit for all analytes that were reported as non-detect or less than the reporting

limit. There is no change in PCB concentrations observed through the decontamination process, most likely due to the low level of PCBs present in the material. There is, however a significant reduction observed in the dioxin/furan concentrations through the decontamination process. The results for the TEV values in the WS

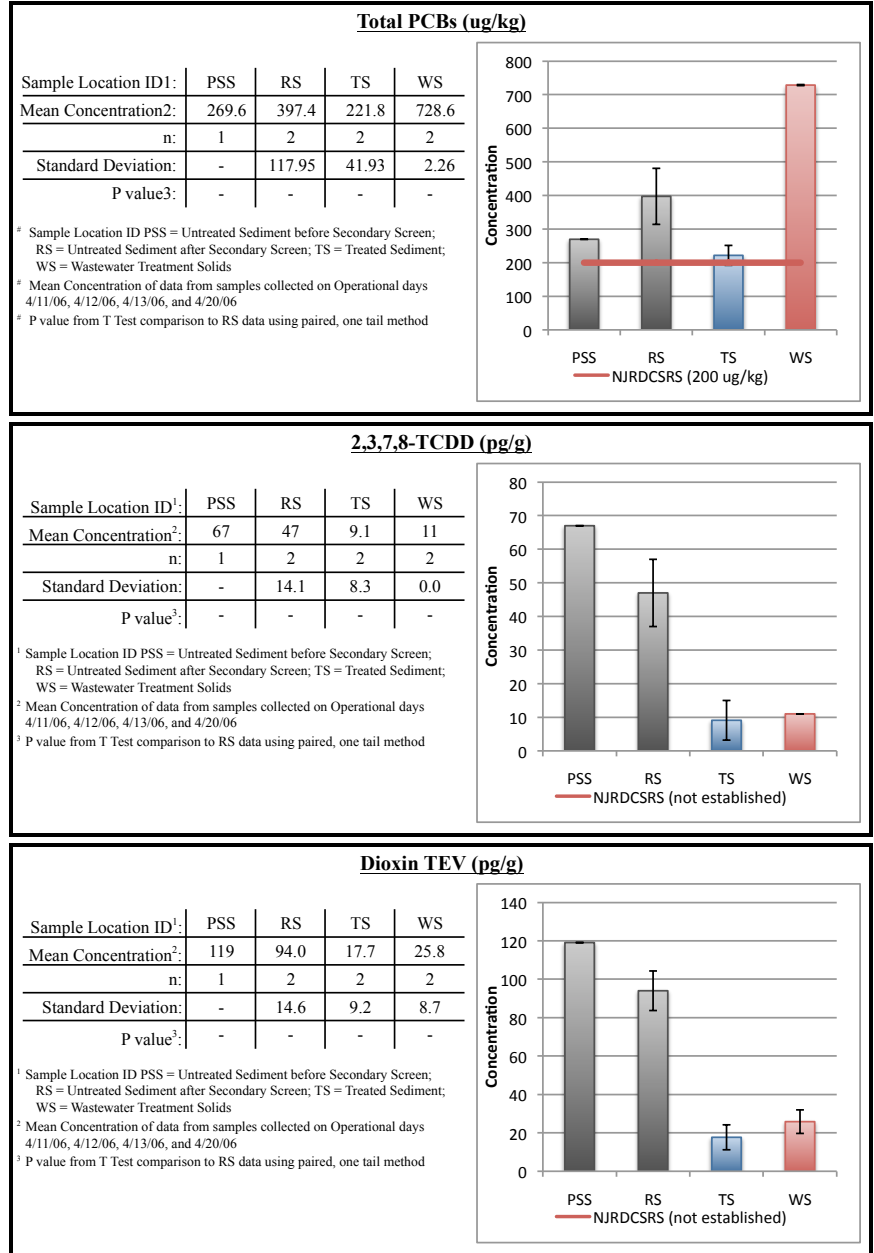

Figure 4-7 Analytical Results for PCBs and Dioxins – Raritan River Sediment

samples are biased high because a significant number of individual dioxins/furans were reported as non-detect or below the reporting limit.

4.3.2 Arthur Kill Sediment

A total of 8,530 cy of dredged material from the Arthur Kill was processed through the BioGenesis sediment decontamination facility on 41 operating days between February 9 and April 28, 2006. Samples were collected of the untreated sediment (sample location PSS), the secondary screenings (sample locations SS1 and SS2), the screened untreated sediment (sample location RS), the treated sediment (sample locations TS, TS1, TS2, and TS3), and the wastewater treatment sludge (sample location WS) in accordance with the QAPP. The analytical results of these samples were used to evaluate the operating performance of the system and to adjust the operational parameters.

The Arthur Kill sediment was significantly different from the Raritan River sediment in physical and chemical (contaminant) characteristics because it had a higher amount of larger grain-sized particles, and it had higher levels of organic contaminants like PAHs and PCBs. As discussed with the Raritan River sediment, the Arthur Kill sediment was treated using a variety of different operating conditions to optimize the performance of the BioGenesisSM Sediment Decontamination Process. As the analytical results of samples collected during operations became available, the operating parameters of the BioGenesisSM Sediment Decontamination Process were adjusted to improve the performance of the process.

Once the optimum operating conditions were determined, the BioGenesisSM Sediment Decontamination Process was operated in a consistent manner from April 11 through April 13, and on April 20, 2006. Presented in Table 4-5 is a summary of the average chemical concentrations in the samples collected during this operational period.

Table 4-5 Average Chemical Concentrations in Samples Collected During Optimum Operating Conditions – Arthur Kill Sediment

Operational Dates:	4/11/2006, 4/12/2006, 4/13/2006, & 4/20/2006			
Sample Location:	PSS	SS1	SS2	RS
Metals/SW6010B (mg/kg)				
Arsenic	29.0	39.1	29.3	31.9
Barium	347	137	236	375
Cadmium	5.5	2.8	2.8	6.4
Chromium, Total	173	126	101	192
Lead	267	267	201	291
Mercury (SW7471A)	7.7	2.9	4.4	8.3
Nickel	46.6	28.4	34.3	52.5
Selenium	2.2	1.3	1.4	2.4
Silver	4.6	1.8	1.8	5.0
Zinc	408	413	384	469
PAHs/SW8270C-SIM (ug/kg)				
Acenaphthene	253	1,333	955	268
Acenaphthylene	380	1,755	1,313	413
Anthracene	738	7,925	2,400	745
Benzo(a)anthracene	1,375	9,675	5,200	1,195
Benzo(a)pyrene	1,295	5,875	4,675	1,190
Benzo(b)fluoranthene	1,425	6,750	5,000	1,365
Benzo(g,h,i)perylene	765	2,875	2,725	738
Benzo(k)fluoranthene	585	2,775	2,075	470
Chrysene	1,500	10,000	5,425	1,418
Dibenz(a,h)anthracene	210	885	775	203
Fluoranthene	2,325	21,000	7,750	2,150
Fluorene	240	1,835	915	283
Indeno(1,2,3-c,d)Pyrene	655	2,575	2,400	638
Naphthalene	315	1,765	1,183	368
Phenanthrene	1,268	14,975	5,675	1,400
Pyrene	2,525	19,225	8,400	2,250
Pesticides/SW80801A (ug/kg)				
Dieldrin	70.0	-	-	15.5
p,p'-DDD	290	-	-	220
p,p'-DDE	310	-	-	310
p,p'-DDT	480	-	-	275
PCBs/SW8082 (ug/kg)				
Total PCB Congeners	269.6	-	-	397.4
Dioxins/Furans (pg/g)				
2,3,7,8-TCDD	67	-	-	47
TEV (using 2005 WHO TEFs)	119.1	-	-	94.0

Note: Where analytes were reported as ND, the average concentration was calculated using ½ of the reporting limit. In calculating the TEVs, ½ of the reporting limit was used for all analytes reported as ND or below the reporting limit.

Table 4-5 Average Chemical Concentrations in Samples Collected During Optimum Operating Conditions – Arthur Kill Sediment (continued)

Operational Dates:	4/11/2006, 4/12/2006, 4/13/2006, & 4/20/2006				
Sample Location:	TS	TS1	TS2	TS3	WS
Metals/SW6010B (mg/kg)					
Arsenic	19.1	14.8	11.9	21.5	47.4
Barium	318	117	229	343	355
Cadmium	2.6	1.5	1.4	2.9	12.5
Chromium, Total	71	49	3.4	81	409
Lead	153	183	119	163	498
Mercury (SW7471A)	4.4	1.4	1.2	4.9	20.9
Nickel	37.6	21.5	28.2	40.9	67.2
Selenium	1.2	0.6	0.5	1.4	3.3
Silver	2.2	0.6	0.9	2.6	10.2
Zinc	241	202	165	249	785
PAHs/SW8270C-SIM (ug/kg)					
Acenaphthene	190	800	117	126	190
Acenaphthylene	353	1,250	193	233	168
Anthracene	610	2,400	388	405	410
Benzo(a)anthracene	1,180	4,850	938	718	493
Benzo(a)pyrene	1,148	4,500	878	710	428
Benzo(b)fluoranthene	1,265	4,825	973	760	520
Benzo(g,h,i)perylene	748	2,650	563	480	258
Benzo(k)fluoranthene	443	1,900	395	295	200
Chrysene	1,320	5,025	973	838	595
Dibenz(a,h)anthracene	208	778	153	131	71
Fluoranthene	1,950	7,900	1,500	1,228	1,088
Fluorene	190	923	123	122	110
Indeno(1,2,3-c,d)Pyrene	635	2,375	500	405	210
Naphthalene	320	1,050	155	220	178
Phenanthrene	1,193	6,250	828	658	525
Pyrene	1,925	7,550	1,550	1,298	1,168
Pesticides/SW80801A (ug/kg)					
Dieldrin	40.5	-	-	-	14.3
p,p'-DDD	215	-	-	-	275
p,p'-DDE	185	-	-	-	420
p,p'-DDT	675	-	-	-	205
PCBs/SW8082 (ug/kg)					
Total PCB Congeners	221.8	-	-	-	728.6
Dioxins/Furans (pg/g)					
2,3,7,8-TCDD	9.1	-	-	-	11.0
TEV (using 2005 WHO TEFs)	17.7	-	-	-	25.8

Note: Where analytes were reported as ND, the average concentration was calculated using ½ of the reporting limit. In calculating the TEVs, ½ of the reporting limit was used for all analytes reported as ND or below the reporting limit.

Presented in Figures 4-8 and 4-9 are graphical representations of the analytical results for arsenic, lead, and mercury of samples collected on the optimum operational days. The concentrations of arsenic in the untreated sediment samples, both before the secondary screener (sample location PSS) and after the secondary screener (sample location RS), in addition to the screened material removed in the secondary screen (sample locations SS1 and SS2) are elevated above the NJRDCSRS. Comparing the data to the RS sample, there is no statistically significant difference between the data from these four sample locations. The concentrations of arsenic in the treated material (sample location TS) was just at the

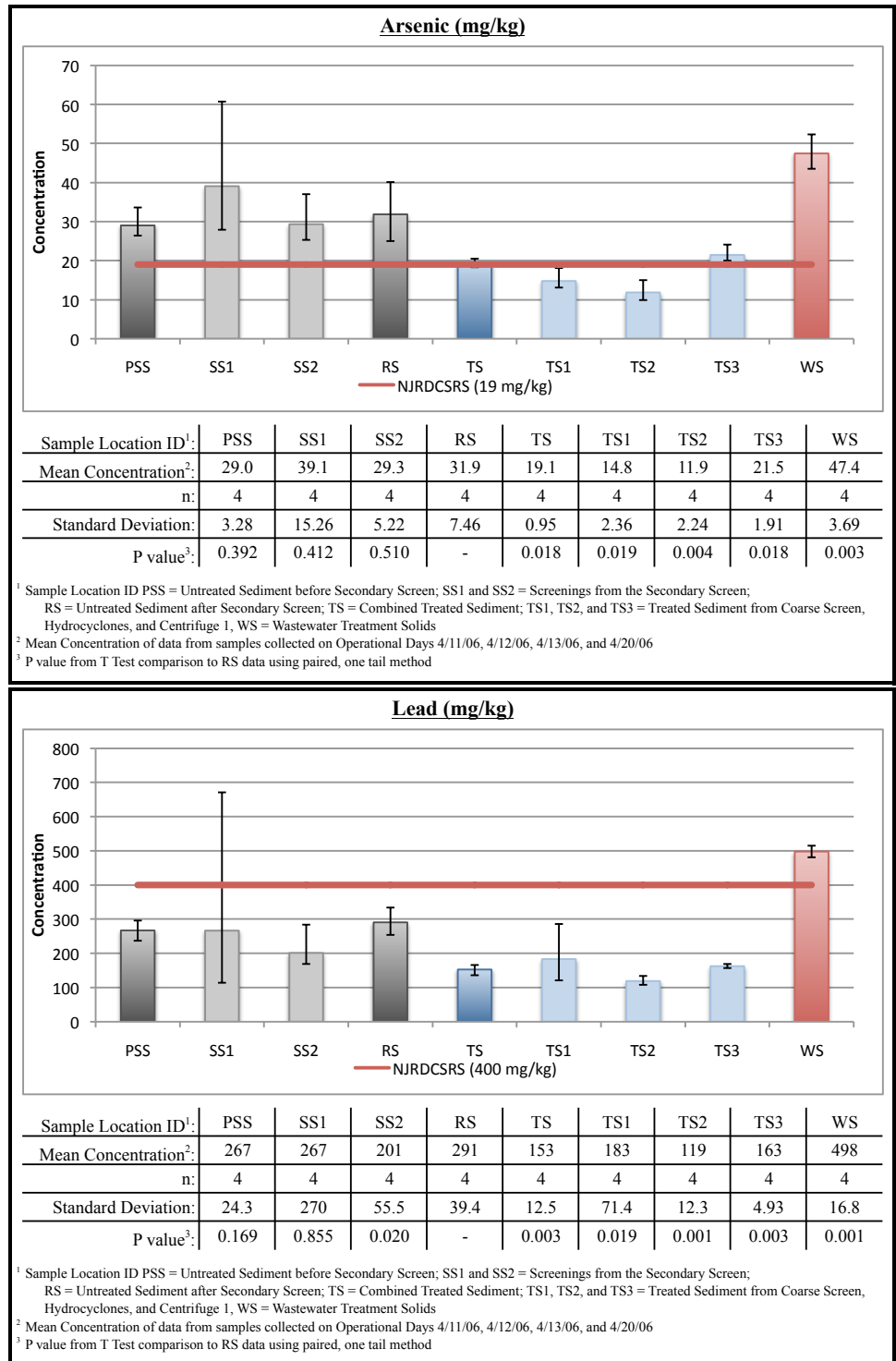

Figure 4-8 Analytical Results for Arsenic and Lead – Arthur Kill Sediment

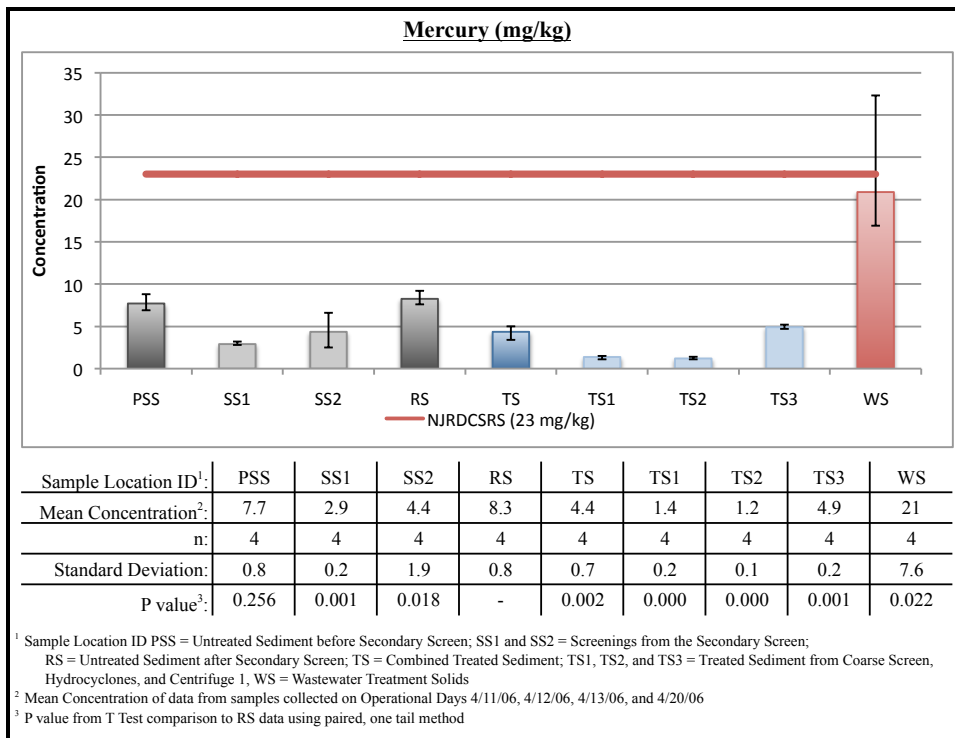

Figure 4-9 Analytical Results for Mercury – Arthur Kill Sediment

NJRDCSRS and the concentrations of arsenic in the wastewater treatment sludge (sample location WS) were higher than the concentrations in the untreated material. The difference in the mean concentrations for these sample locations is statistically significant (p values less than 0.05).

Even though the concentrations of lead and mercury were below the NJRDCSRS for the untreated sediment (sample locations PSS and RS), a similar trend is observed where the treated material (sample location TS and subsamples TS1, TS2, and TS3) has lower concentrations of metals than the untreated sediment samples and the wastewater treatment sludge sample (sample location WS) had higher concentrations than those in the untreated material. This trend indicates that metals were transferred from the sediment particles into the liquid phase in the BioGenesis™ Collision Chamber and precipitated in the wastewater treatment sludge. It also confirms that metals are adsorbed to the surface area of the sediment particles and not part of the particle matrix since the finest particles which would have the highest surface area per unit volume and therefore the highest level of contamination are concentrated in the wastewater treatment sludge.

The analytical results for select PAHs are presented graphically in Figures 4-10 and 4-11. From the beginning of operations on the Arthur Kill sediment, the concentrations of PAHs were challenging. After the secondary screen was installed on February 24, 2006, samples of the screenings (sample locations SS1 and SS2)

showed significantly elevated concentrations of PAHs. The material removed by this secondary screen from the sediment slurry was rock, gravel, and debris not removed in the primary screen along with a significant amount of organic detritus (leaves, twigs, grass, etc.). Comparing the analytical results of the samples of the sediment prior to the secondary screen (PSS sample location) to the samples of the sediment after the secondary screen (sample location RS) shows no statistically significant difference in the mean concentrations. Therefore, while the concentrations of PAHs in the material removed by the secondary screener were elevated, the amount of material removed from the sediment slurry

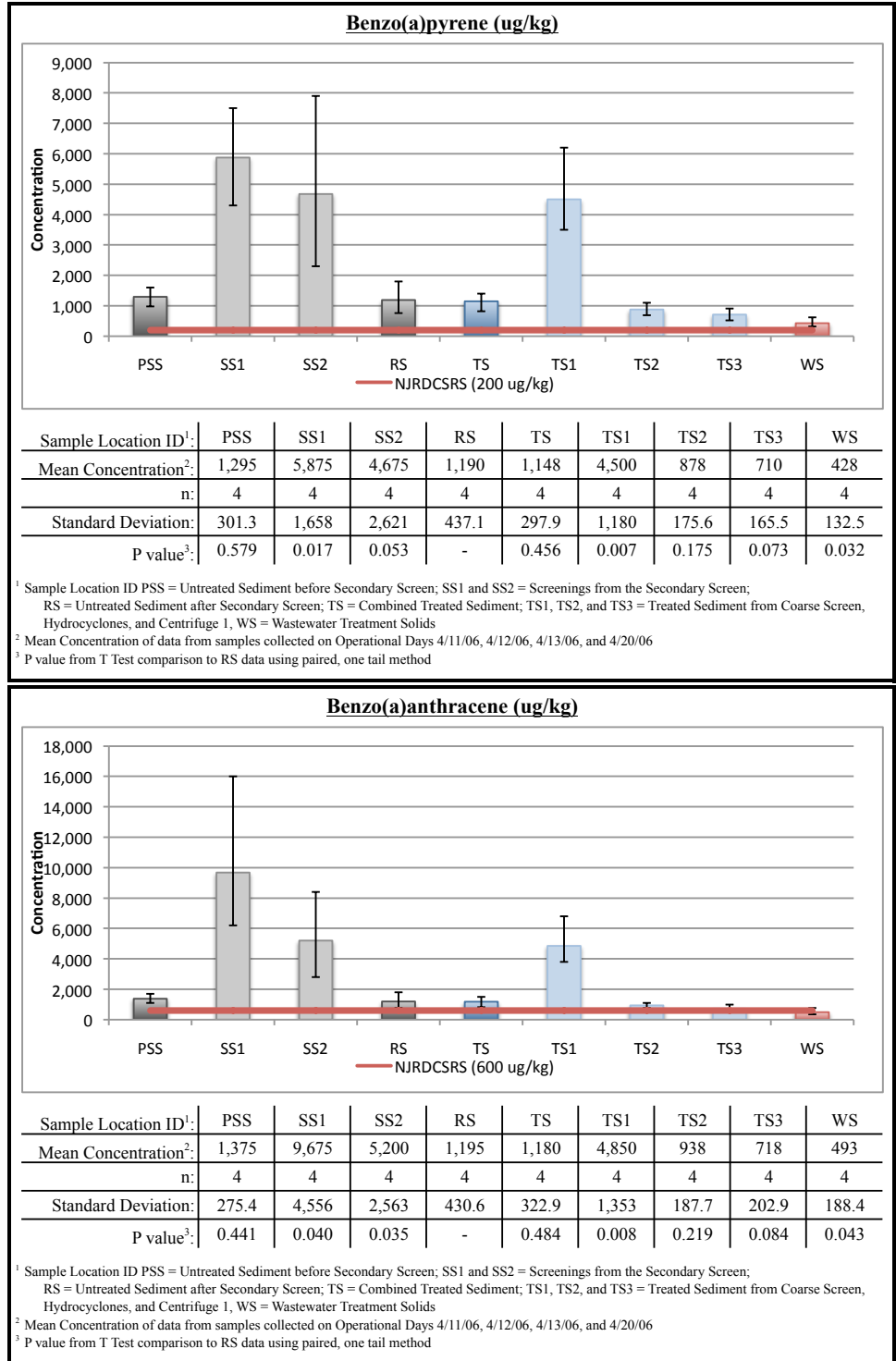

Figure 4-10 Analytical Results for Benzo(a)pyrene and Benzo(a)anthracene – Arthur Kill

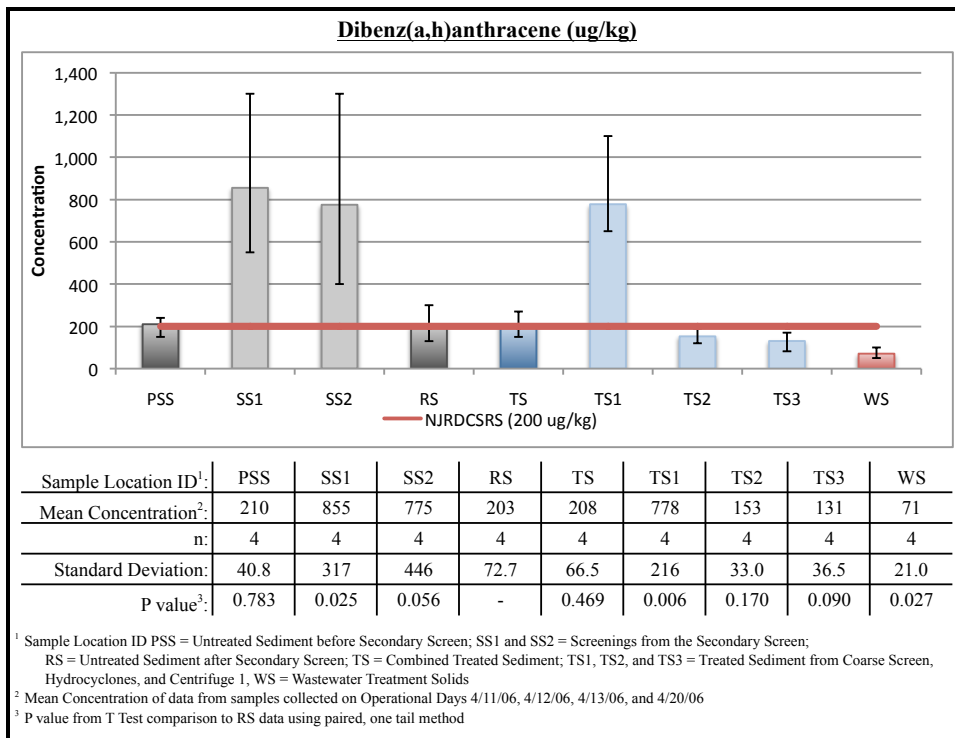

Figure 4-11 Analytical Results for Dibenzo(a,h)anthracene – Arthur Kill Sediment

was not enough to have an impact on the concentration of PAHs entering the BioGenesisSM Sediment Decontamination Process.

Comparing the mean concentrations of PAHs in the decontaminated sediment (sample location TS) to the untreated sediment (sample location RS) shows no statistically significant difference in the concentrations (p values are much greater than 0.05). This indicates that the mean concentrations are similar and that the process had little or no impact on the PAH concentrations. In order to understand this, the concentrations of PAHs in the subsamples of the decontaminated sediment (sample locations TS1, TS2, and TS3) are evaluated. This data shows that the coarser material (sample location TS1) had statistically significant higher levels of PAHs than the finer grain material (sample locations TS2 and TS3). As discussed previously, this is unexpected since the surface area per unit volume of the finer grain-sized particles is significantly higher than the surface area per unit volume of larger grain-sized particles and higher surface areas typically result in higher concentrations of adsorbed contaminants. This observation leads to a theory of the presence of PAH contamination in the Arthur Kill sediment. It seems that the PAHs are adsorbed to, or absorbed in, the organic detritus material mixed with the sediment. This theory is supported by the higher affinity of organic contaminants such as PAHs to organic material when compared to the affinity for inorganic sediment particles. See Section 4.3.5 of this report for further discussion of PAHs.

PCBs, dioxins, and furans in the sediment from the Arthur Kill were below the NJRDCSRS, however, in accordance with the QAPP, some samples collected during operations were analyzed for these compounds. Presented in Figure 4-12 are graphical representations of the analytical results for total PCBs, 2,3,7,8-TCDD, and Dioxin TEVs for samples collected during this operational period. There is a reduction in PCB concentrations observed through the decontamination process (sample locations PSS and RS compared to sample location TS), with an increase in the concentrations in the wastewater treatment sludge (sample location WS). There is a significant reduction observed in the dioxin and furan concentrations through the process. These results are consistent with the PCB and dioxin results for the Raritan River sediment.

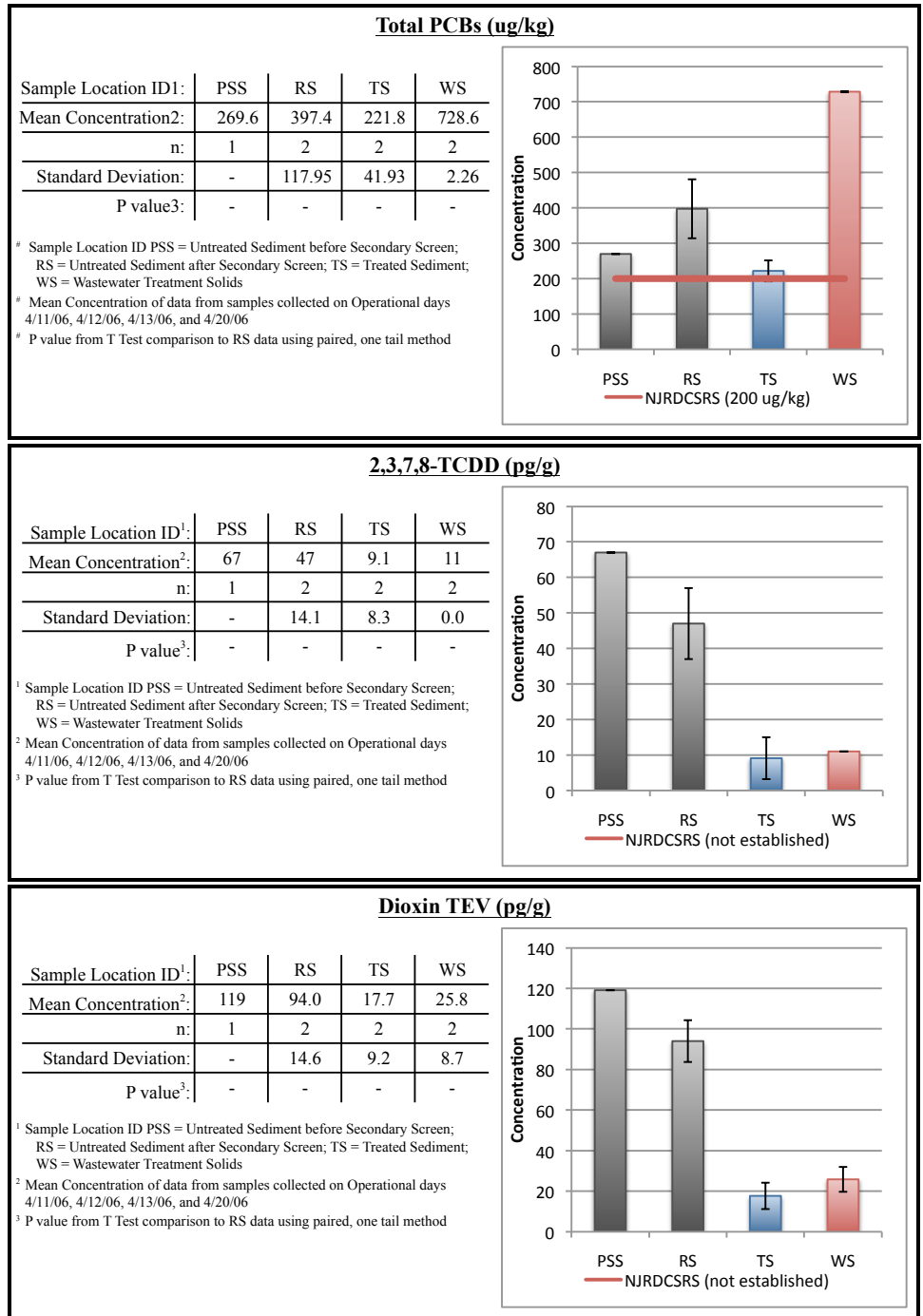

Figure 4-12 Analytical Results for PCBs and Dioxins – Arthur Kill Sediment

4.3.3 Lower Passaic River Sediment

A total of 2,655 cy of dredged material from the Lower Passaic River was processed through the BioGenesis sediment decontamination facility on 18 operating days between January 19 and May 4, 2006. Samples were collected of the untreated sediment (sample location PSS), the secondary screenings (sample locations SS1 and SS2), the screened untreated sediment (sample location RS), the treated sediment (sample locations TS, TS1, TS2, and TS3), and the wastewater treatment sludge (sample location WS) in accordance with the QAPP. The analytical results of these samples were used to evaluate the operating performance of the system and to adjust the operational parameters.

The sediment from the Lower Passaic River was similar to the sediment from the Arthur Kill with the exception of higher levels of PAHs and dioxins. During the initial operations on the sediment from the Lower Passaic River, significant problems were encountered with the sediment plugging in the piping and processing equipment. This was due to an unusually high amount of trash and debris in the Lower Passaic River sediment that was dredged and delivered to the demonstration project. The debris included household trash such as plastic bags, straws, and food wrappers as well as organic debris such as twigs and leaves. The debris caused blockages in the piping and process equipment and did not allow for consistent uninterrupted operations.

Once the secondary screening step was installed, operations dramatically improved and the system could be operated continuously. Following the installation of the secondary screen, several additional days of operation were conducted with the sediment from the Lower Passaic River at varying operating conditions to determine the most effective operating scenario. This culminated in the operations conducted from May 2 through May 4, 2006 when the BioGenesisSM Sediment Decontamination Process was operated in a consistent manner. Presented in Table 4-6 is a summary of the average chemical concentrations in the samples collected during this operational period.

Table 4-6 Average Chemical Concentrations in Samples Collected During Optimum Operating Conditions – Lower Passaic River Sediment

Operational Dates:	5/2/2006, 5/3/2006, & 5/4/2006			
Sample Location:	PSS	SS1	SS2	RS
Metals/SW6010B (mg/kg)				
Arsenic	12.1	14.3	14.6	10.5
Barium	200	139	168	175
Cadmium	7.4	6.2	6.9	6.2
Chromium, Total	208	154	215	177
Lead	424	312	417	354
Mercury (SW7471A)	4.5	3.0	4.0	4.0
Nickel	53.1	46.1	61.2	46.0
Selenium	2.2	7.6	2.4	1.3
Silver	7.4	4.3	5.1	6.1
Zinc	728	905	821	629
PAHs/SW8270C-SIM (ug/kg)				
Acenaphthene	230	293	557	230
Acenaphthylene	487	557	2,267	530
Anthracene	937	3,840	2,167	877
Benzo(a)anthracene	2,300	3,167	7,133	2,067
Benzo(a)pyrene	2,167	2,367	7,200	2,067
Benzo(b)fluoranthene	2,633	2,700	6,300	2,467
Benzo(g,h,i)perylene	1,700	1,467	4,467	1,733
Benzo(k)fluoranthene	977	1,053	2,733	897
Chrysene	2,767	3,833	7,600	2,600
Dibenz(a,h)anthracene	393	377	1,107	410
Fluoranthene	3,900	5,367	8,467	3,800
Fluorene	277	377	660	273
Indeno(1,2,3-c,d)Pyrene	1,400	1,197	3,500	1,467
Naphthalene	267	433	453	230
Phenanthrene	2,100	2,700	3,267	1,700
Pyrene	3,700	5,000	10,233	3,433
Pesticides/SW80801A (ug/kg)				
Dieldrin	44	-	-	80
p,p'-DDD	350	-	-	30
p,p'-DDE	120	-	-	81
p,p'-DDT	170	-	-	51
PCBs/SW8082 (ug/kg)				
Total PCB Congeners	520.4	-	-	442.0
Dioxins/Furans (pg/g)				
2,3,7,8-TCDD	330	-	-	460
TEV (using 2005 WHO TEFs)	419	-	-	517

Note: Where analytes were reported as ND, the average concentration was calculated using ½ of the reporting limit. In calculating the TEVs, ½ of the reporting limit was used for all analytes reported as ND or below the reporting limit.

Table 4-6 Average Chemical Concentrations in Samples Collected During Optimum Operating Conditions – Lower Passaic River Sediment (continued)

Operational Dates:	5/2/2006, 5/3/2006, & 5/4/2006				
Sample Location:	TS	TS1	TS2	TS3	WS
Metals/SW6010B (mg/kg)					
Arsenic	7.23	13.1	3.07	7.53	21.0
Barium	131	174	71	135	330
Cadmium	3.7	4.5	1.7	3.8	13.9
Chromium, Total	92	128	40	95	452
Lead	232	513	201	238	627
Mercury (SW7471A)	3.0	3.1	1.1	3.0	9.3
Nickel	36.5	43.4	22.1	37.5	67.3
Selenium	1.0	1.8	0.5	1.0	2.9
Silver	3.0	2.2	1.5	3.1	16.3
Zinc	368	689	223	343	1,197
PAHs/SW8270C-SIM (ug/kg)					
Acenaphthene	220	1,193	129	220	183
Acenaphthylene	477	3,033	290	440	400
Anthracene	867	4,567	503	770	567
Benzo(a)anthracene	2,067	10,767	1,433	1,800	1,057
Benzo(a)pyrene	1,967	10,400	1,400	1,733	1,047
Benzo(b)fluoranthene	2,300	10,000	1,567	2,000	1,500
Benzo(g,h,i)perylene	1,633	6,767	1,087	1,467	957
Benzo(k)fluoranthene	370	3,833	563	850	577
Chrysene	2,600	11,900	1,633	2,300	1,500
Dibenz(a,h)anthracene	400	1,867	263	363	213
Fluoranthene	3,667	15,533	2,400	3,233	2,367
Fluorene	277	1,447	157	267	193
Indeno(1,2,3-c,d)Pyrene	1,303	5,500	910	1,163	767
Naphthalene	283	907	116	270	163
Phenanthrene	1,667	9,233	1,153	1,533	770
Pyrene	3,233	14,267	2,200	3,033	2,233
Pesticides/SW80801A (ug/kg)					
Dieldrin	34	41	22	40	-
p,p'-DDD	98	100	96	140	-
p,p'-DDE	89	93	80	97	-
p,p'-DDT	120	150	110	160	-
PCBs/SW8082 (ug/kg)					
Total PCB Congeners	385.7	-	-	-	609.1
Dioxins/Furans (pg/g)					
2,3,7,8-TCDD	58	-	-	-	57.0
TEV (using 2005 WHO TEFs)	71	-	-	-	84.0

Note: Where analytes were reported as ND, the average concentration was calculated using ½ of the reporting limit. In calculating the TEVs, ½ of the reporting limit was used for all analytes reported as ND or below the reporting limit.

Presented in Figures 4-13 and 4-14 are graphical representations of the analytical results for select metals (arsenic, lead, and mercury) of samples collected on the optimum operating days on the sediment from the Lower Passaic River. Comparing the mean concentrations of arsenic in the untreated sediment samples before the secondary screener (sample location PSS) and after the secondary screener (sample location RS), shows statistically no significant difference between the data for these two sample locations as expected. The concentration of arsenic in the treated material (sample location TS), however, shows a statistically significant decrease in concentration. This is from decontamination of the sediment particles. In addition, the concentration of arsenic in the wastewater treatment sludge

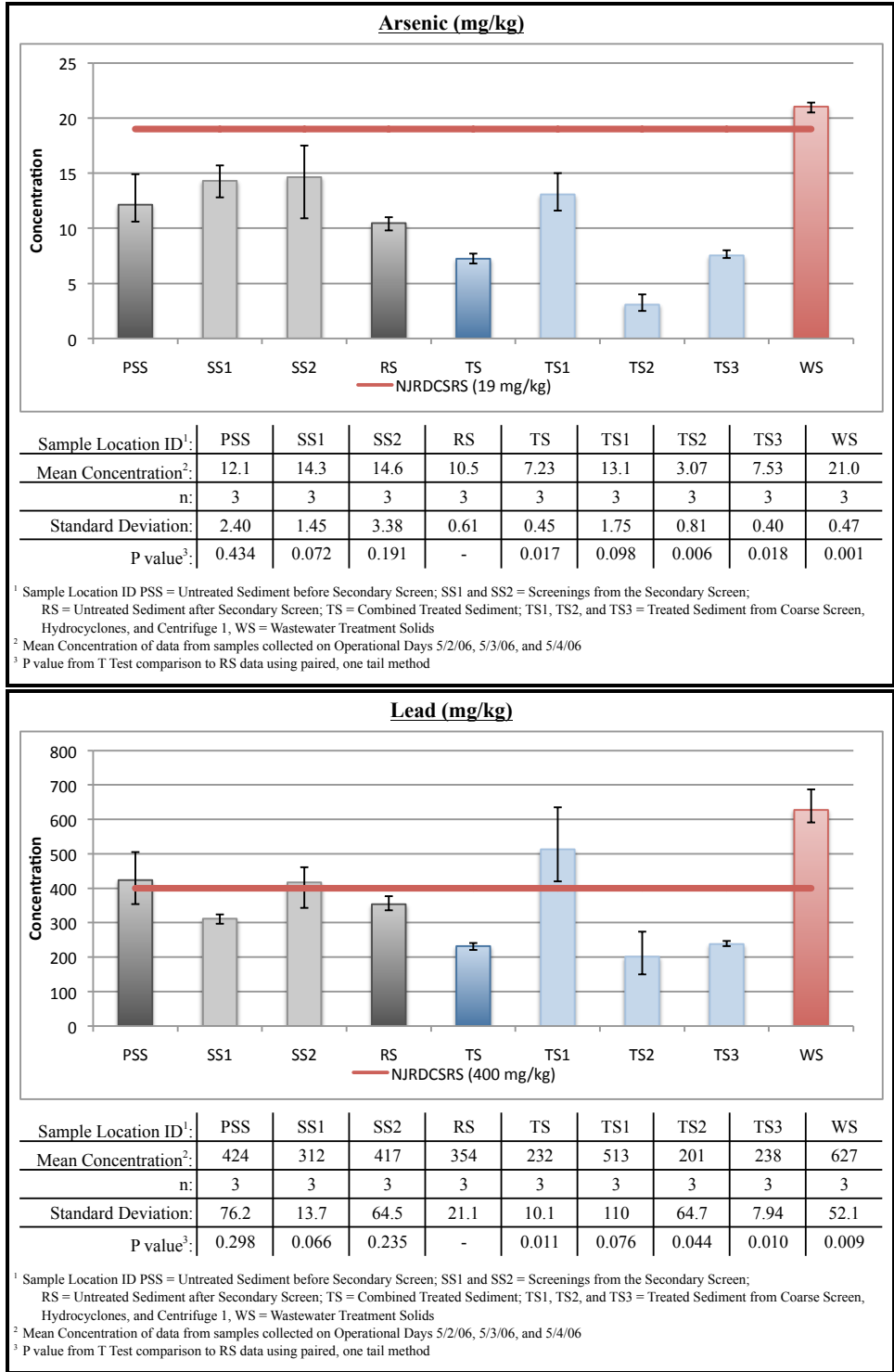

Figure 4-13 Analytical Results for Arsenic and Lead – Lower Passaic River Sediment

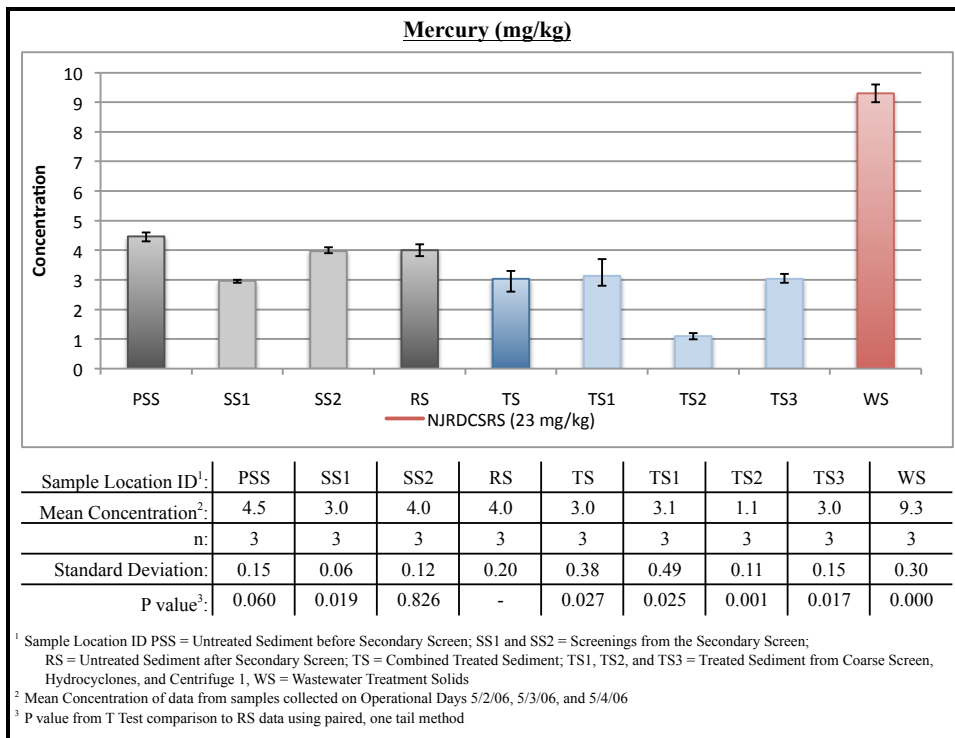

Figure 4-14 Analytical Results for Mercury – Lower Passaic River Sediment

sediment sample (sample location PSS) were elevated above the NJRDCSRS. The concentration of lead in the treated material (sample location TS) was below the NJRDCSRS and the concentration of lead in the wastewater treatment sludge (sample location WS) was higher than the concentration in the untreated material. The concentrations of mercury followed similar trends, but were below the NJRDCSRS for the untreated sediment (sample locations PSS and RS) and the treated material (sample location TS).

The analytical results for select PAHs are presented graphically in Figures 4-15 and 4-16. As with the Arthur Kill sediment, the concentrations of PAHs in the Lower Passaic River sediment were challenging. After the secondary screen was installed on February 24, 2006, samples of the screenings from this screen showed significantly elevated concentrations of PAHs, but the removal of these PAHs was not enough to have a significant impact on the concentration of PAHs entering the decontamination process as illustrated by the concentrations of PAHs in the RS sample. The concentrations of benzo(a)pyrene and benzo(a)anthracene in the treated sediment sample (sample location TS) were above the NJRDCSRS.

(sample location WS) had higher concentrations than those in the untreated material indicating that arsenic was transferred from the sediment particles into the liquid phase in the collision chamber and precipitated in the wastewater treatment sludge.

The concentrations of lead in the untreated

Comparing the concentrations of PAHs in subsamples TS1, TS2, and TS3 it can be observed again that the coarser material (sample location TS1) had higher levels of PAHs than the finer grain material (sample locations TS2 and TS3) which points toward PAHs in the organic detritus material mixed with the sediment. See Section 4.3.5 of this report for further discussion of PAHs.

The treatment of PCBs and dioxins/furans in the Lower Passaic River sediment was very successful. Presented in Figures 4-17 and 4-18 are graphical representations of the analytical results for

total PCBs, 2,3,7,8-TCDD, and Dioxin TEVs for samples collected during operations on May 2 through May 4, 2006. There is a reduction in PCB concentrations observed

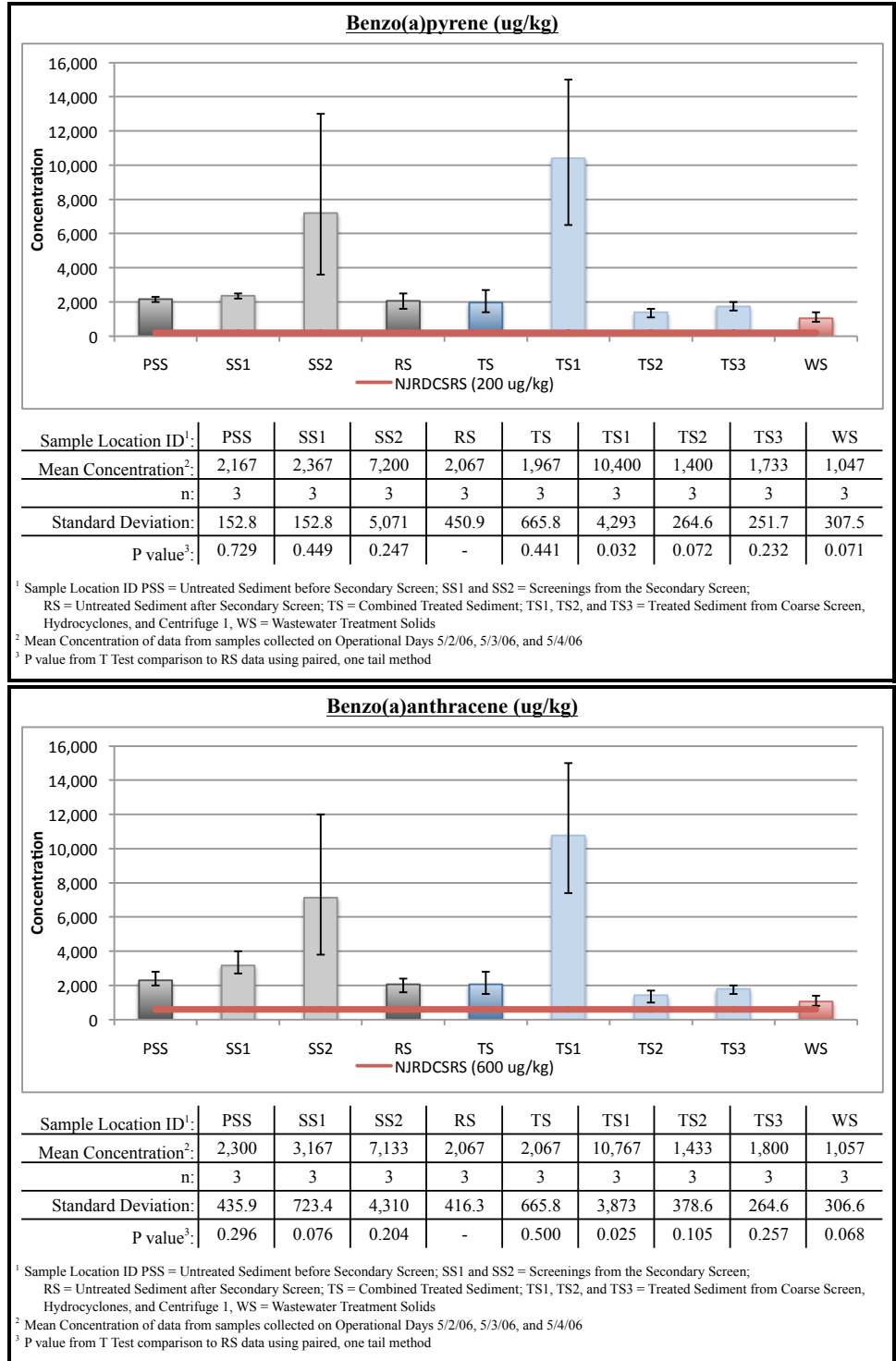

Figure 4-15 Analytical Results for Benzo(a)pyrene and Benzo(a)anthracene – Lower Passaic River Sediment

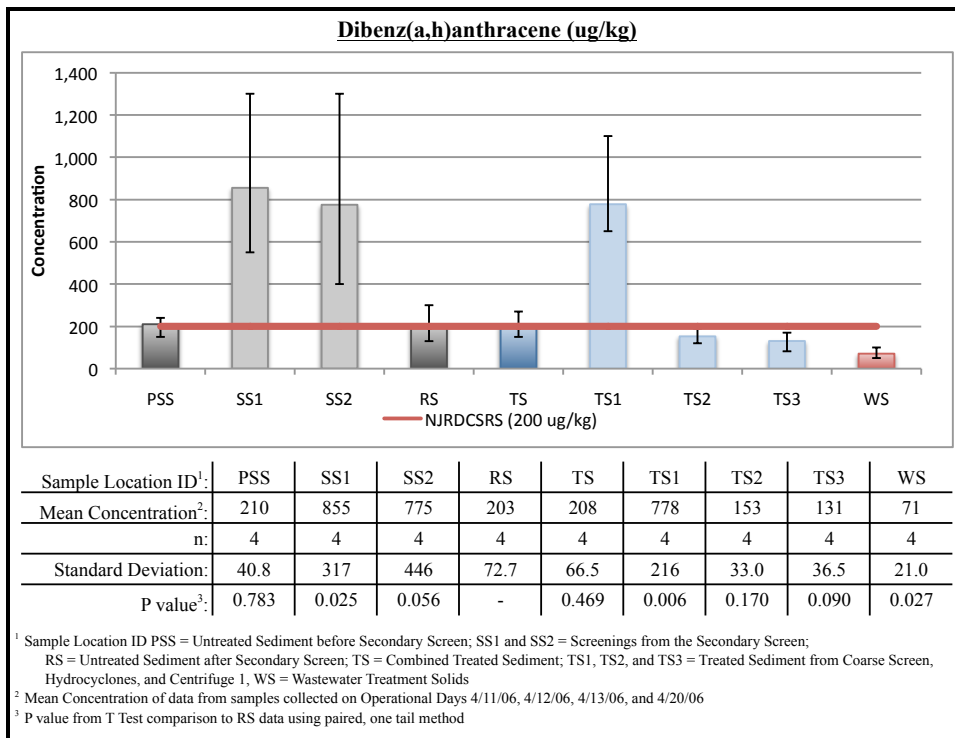

Figure 4-16 Analytical Results for Dibenz(a,h)anthracene – Lower Passaic River Sediment

compared to sample location TS). These results are consistent with the Raritan River and Arthur Kill results.

through the decontamination process (sample locations PSS and RS compared to sample location TS), with an increase in the concentrations in the wastewater treatment sludge (sample location WS). Dioxin and furan concentrations were reduced by approximately 85% during processing (sample location PSS

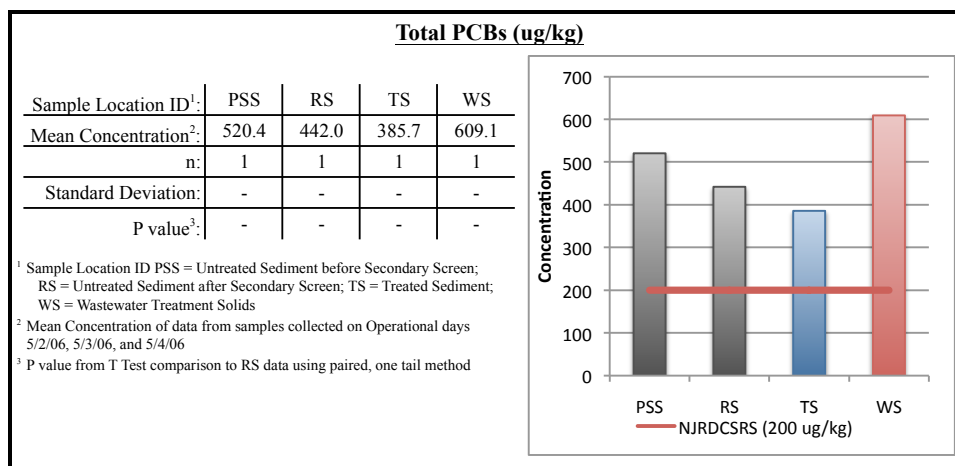

Figure 4-17 Analytical Results for Total PCBs – Lower Passaic River Sediment

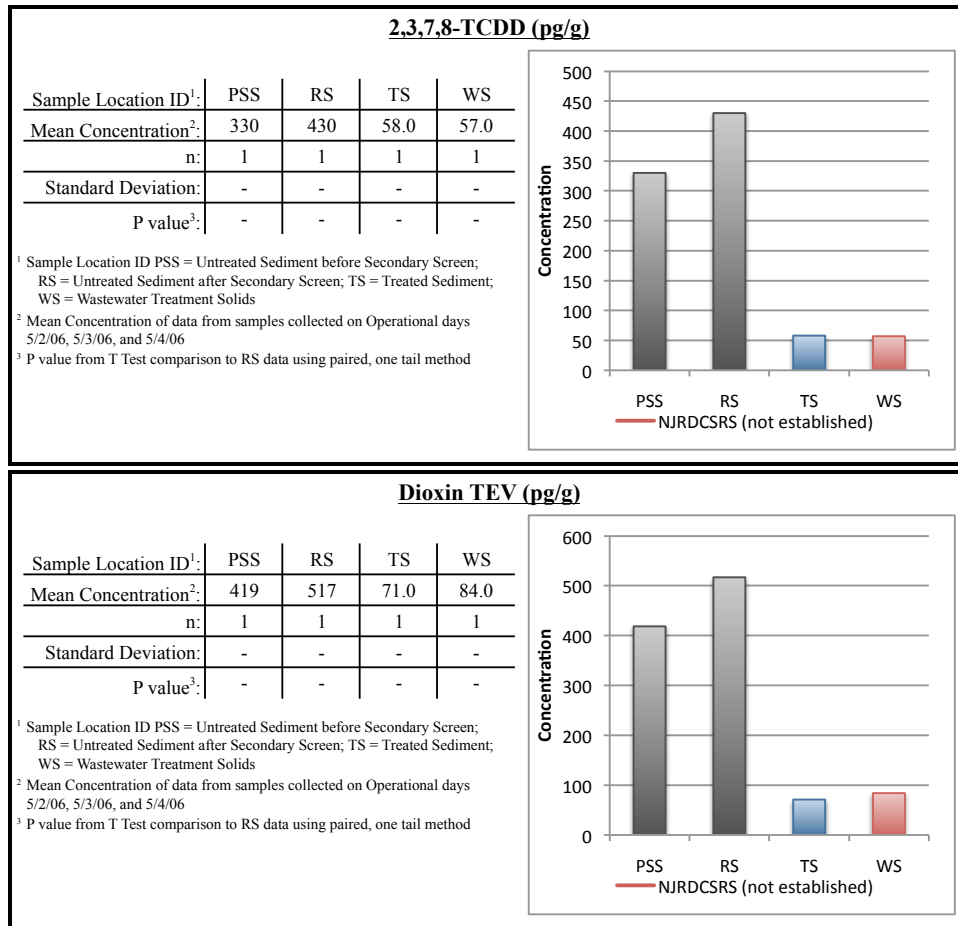

Figure 4-18 Analytical Results for Dioxins – Lower Passaic River Sediment

4.3.4 Wastewater Treatment

Samples of the treated wastewater were collected following the carbon filters, prior to discharge to the POTW, in accordance with MCUA's and the Township of Woodbridge's discharge requirements. Samples were collected daily at first, then weekly after the first two months. As required in the discharge permit, monthly reporting to the MCUA was performed throughout the project. Copies of the monthly monitoring reports are provided in Appendix D of this report. Provided in Table 4-7 is a summary of the maximum and average concentrations of contaminants in the treated wastewater.

Table 4-7 Summary of Treated Wastewater Sampling Results

Parameter (units)	January 2006		February 2006		March 2006		April 2006		May 2006	
	Average	Max	Average	Max	Average	Max	Average	Max	Average	Max
Flow (mgd)	0.035	0.107	0.051	0.153	0.026	0.126	0.067	0.177	0.024	0.231
Flow Rate (gpm)	24	191	35	106	18	88	46	123	17	160
Minimum pH (grab)	7.4		6.7		6.9		6.8		7.6	
Maximum pH (grab)	12.1		7.9		8.8		7.8		8.8	
BOD, 5 Day (mg/L)	15.2	136	30.6	57.2	24.8	258	79.5	90.0	223	357
COD (mg/L)	130.2	666	346	711	118	703	250	294	563	852
TSS (mg/L)	7.31	80	5.47	19.2	0.85	10.4	3.8	9.2	9.9	27.6
TPH (mg/L)	<5	<50	<5	<5	<1.66	16.2	4.05	10.7	2.5	2.6
Total Cyanide (mg/L)	<0.01	<0.01	<0.01	<0.01	<0.01	<0.01	0.053	0.19	<0.006	<0.008
Arsenic (mg/L)	0.02	0.14	0.010	0.022	<0.01	<0.01	<0.005	<0.01	0.010	0.015
Cadmium (mg/L)	<0.005	<0.005	0.009	0.021	<0.005	<0.005	<0.003	<0.005	0.0059	0.0081
Total Chromium (mg/L)	<0.005	<0.005	0.003	0.005	<0.005	<0.005	<0.002	<0.005	0.004	0.005
Copper (mg/L)	0.009	0.124	0.483	1.33	0.012	0.357	<0.012	<0.025	<0.013	<0.017
Lead	<0.003	<0.003	0.297	0.798	0.006	0.039	<0.004	<0.005	0.662	1.27
Mercury (mg/L)	<0.0002	<0.0002	<0.0001	<0.0002	<0.0002	<0.0002	<0.0001	<0.002	<0.0001	<0.002
Nickel (mg/L)	0.037	0.552	0.210	0.427	0.075	0.361	0.038	0.093	0.361	0.571
Silver (mg/L)	<0.005	<0.005	<0.004	<0.005	<0.005	<0.005	<0.004	<0.005	<0.002	<0.005
Zinc (mg/L)	0.075	1.6	1.84	4.24	0.075	1.02	<0.018	<0.04	<0.24	<0.368
Total Toxic Organics (mg/L)	<0.1	0.093	<0.01	<0.01	<0.076	<0.076	<0.076	<0.076	<0.076	<0.076
Volatile Organics (mg/L)	<0.02	0.03	<0.02	<0.02	<0.02	<0.03	<0.02	<0.03	<0.02	<0.03
Base/Neutrals (mg/L)	<0.01	0.093	<0.01	<0.01	<0.01	<0.076	<0.01	<0.076	<0.01	<0.076
Acid Extractables (mg/L)	<0.0001	<0.0001	<0.0001	<0.0001	<0.001	<0.001	<0.0001	<0.0001	<0.0001	<0.0001
Pesticides (ppb)	<0.01	<0.01	<0.01	<0.01	<0.01	<0.01	<0.01	<0.01	<0.01	<0.01
PCBs (ppb)	<0.2	<0.2	<0.2	<0.2	<0.2	<0.2	<0.2	<0.2	<0.02	<0.2

mgd = million gallons per day
 BOD = biological oxygen demand
 COD = chemical oxygen demand

Throughout the four and a half months of operations, there were a few cases where the concentrations of metals, namely copper, lead, nickel, and zinc, exceeded the discharge limits and one case where the pH exceeded the discharge limit. In all cases, when the violation was determined (by receipt of the analytical data or observation of the pH readings), the wastewater treatment system was adjusted and the discharge concentrations were brought back into compliance. During commercial-scale operations, the wastewater will be monitored to ensure compliance with the discharge regulations.

4.3.5 Bench-Scale Testing of Lower Passaic River Sediment

An overview of the analytical results from the demonstration project for organic contaminants shows that PAH and PCB concentrations were only marginally reduced, and dioxin concentrations were reduced in the sediment with higher efficiency. Since dioxins and PCBs are much more complex molecules than PAHs, it would seem that PAHs would be easier to clean from sediment particles.

A second observation that was unexpected the concentrations of PAHs in the fractions of the treated sediment and the wastewater treatment sludge decreased with decreasing particle sizes. Assuming that sediment contamination occurs on the surface area of the inorganic sediment particles, and understanding that surface area per volume increases exponentially as particle sizes get smaller, one would expect PAH concentrations to increase with decreasing particle sizes.

To investigate the reasons for the variations between the organic contaminant removal efficiencies and develop methods for improving them, BioGenesis conducted a series of bench tests using dredged material from the Lower Passaic River. The tests were conducted at the BioGenesis testing facility in Milwaukee, Wisconsin, from January through May 2008. A total of 19 tests were performed, and are described in Appendix E. Iterative testing allowed the use of a variety of chemical formulations and facilitated the operation of various equipment configurations during processing.

As discussed previously, the BioGenesisSM Sediment Decontamination Technology is a physical/chemical process that uses impact forces and chemical forces to strip contaminants from the surface of sediment particles and suspend them in the water phase where they can be separated from the sediment. The physical characteristics of the sediment particles (i.e., density, porosity, grain size, chemical structure, etc.) play a large role in the performance of the decontamination process. However, none of these characteristics would explain the difference in treatment of different organic contaminants from a single sediment source. The chemical and physical characteristics of the contaminants are the differentiating factors.

Several characteristics of organic contaminants that can affect the distribution of the contaminants in the sediment matrix include the affinity for organic carbon (K_{oc}), affinity for different grain size fractions of sediment particles, polarity and/or solubility in water, and molecular rigidity. A review of these characteristics, coupled with observations made during the bench tests in Milwaukee, could explain the differences in removal efficiencies.

All three classes of compounds are somewhat insoluble in water with PAHs and PCBs being only slightly soluble and dioxins being practically insoluble. (Yalkowsky, 2003). Also all three classes of organic compounds have high affinities towards organic matter with PCBs and dioxins having higher affinity than PAHs. (NYDEC, 1994). Finally, dioxins have molecules that are more rigid than PCBs and PAHs. (Zhu, 2003).

All of these factors, along with the high TOC concentrations in the Lower Passaic River and Arthur Kill sediment, could indicate the nature of the organic contaminants in the sediment. The PAHs, dioxins, and PCBs could be primarily absorbed in the organic material with lesser amounts adsorbed to the sediment surface. When processed through the BioGenesisSM Sediment Decontamination Process, the impact forces have the largest effect on the rigid contaminants adsorbed to the sediment particles. Once the contaminants are dislodged from the particle surface, the solubility of the contaminants in water will dictate where the

contaminants will end up. Insoluble contaminants will tend to re-attach to the solid surface of the sediment particles. The added washing chemicals help to overcome the lack of solubility of certain organic contaminants and allow them to be suspended in the water phase. The efficiency of the collision impact forces is reduced for contaminants absorbed in organic matter (plant and animal based fibrous material), which is porous, spongy, and less dense than sediment particles. Higher molecular rigidity will help improve the impact efficiency.

Since harbor sediment is such a complex material, contaminated with a variety of contaminants, several processing steps and solid/liquid separation steps are required to decontaminate the sediment. During the demonstration project the secondary screen removed a portion of the large organic fiber and the chemical analysis of this material showed it was highly saturated with PAHs. However, the screen couldn't remove the fine organic material (short fibers), which was removed in the solid/liquid separation steps.

During the bench testing in Milwaukee, the untreated sediment, treated sediment, and residual inorganic solids in the treated sediment (particles which were left after burning the treated sediment in a laboratory oven at 1,000° C) were examined under a microscope. These examinations showed that there was a significant portion of organic matter remaining in the treated sediment. The level of PAHs and other organic contaminants in the treated sediment appears to be proportional to the percentage of organic matter remaining in the sediment following treatment. In addition, settling tests of the treated sediment showed that the organic matter settles at about the same rate as the sediment particles. This implies that solid/liquid separation through hydrocyclones and centrifuges can't differentiate between the cleaned sediment particles and the PAH-laden organic fiber.

In May 2008, the final bench experiments in Milwaukee showed that a micro-floatation technique using fine air bubbles (30 to 40 microns) would allow the PAH contaminated organic fibers to be floated and separated from solid particles with similar densities. Analytical results of the sample of the recovered organic fibers

showed total PAH concentrations as high as 110,000 µg/kg, while samples of the recovered sediment particles showed concentrations of 2,000 to 8,000 µg/kg. Thus for sediment where there is a significant fraction of organic material in the sediment and PAHs are a compound of concern, micro-floatation will be implemented as part of the solid/liquid separation step.

Micro-floatation is routinely used in water and wastewater treatment for the removal of non-aqueous organic material. The BioGenesis™ Gondola utilizes micro-floatation to separate light organic material and non-aqueous organic material from the sediment slurry. The functionality of the BioGenesis™ Gondola was successfully tested during the 1999 Pilot Demonstration Project, but there was no significant amount of free-phase organic material or organic detritus in the sediment slurry during that project. Since no free-phase organic material was removed from the sediment in the 1999 Pilot Demonstration Project, BioGenesis™ Gondola was not utilized in the Full-Scale Demonstration Project.

The utilization of a micro-floatation unit or the BioGenesis™ Gondola in the future will require off-gas treatment (e.g., granular activated carbon) to control the potential release of VOCs and SVOCs. It is anticipated that this will require a discharge permit approval from the NJDEP.

4.3.6 Manufactured Soil Demonstration

An important goal of the BioGenesis sediment decontamination demonstration project was the generation of a treated sediment product that could be used for unrestricted beneficial uses. Decontaminated sediment from the BioGenesisSM Sediment Decontamination Technology retains the physical structure of the contaminated sediment (grain size distribution, mineral content, etc.), however most of the organic material has been removed with the contaminants. The decontaminated sediment can be used as a major component of manufactured topsoil or other construction grade products.

A demonstration project was conducted at Montclair State University using 20 cy of decontaminated sediment from the Lower Passaic River to evaluate manufactured topsoil made from the decontaminated sediment. The 20 cy of decontaminated sediment used for this demonstration project was removed from the Decontaminated Sediment Storage Area where the decontaminated Lower Passaic River sediment was stockpiled and does not represent any particular day of processing. The decontaminated sediment was transported to Bridgeport Harbor where it was stockpiled while the manufactured soil demonstration project was developed, and in the summer of 2008, it was transported from Bridgeport Harbor to MSU.

The decontaminated sediment was evaluated by the Agricultural Experiment Station of Rutgers, The State University of New Jersey, (Rutgers) to determine what amendments would be needed to manufacture topsoil from the decontaminated sediment. Tests performed by Rutgers included mechanical analysis, (percent gravel, sand, silt, and clay), electrical conductivity (a measure of the soluble salt level), organic content, pH, and nutrient availability. In addition, a composite sample was collected of the decontaminated sediment and sent for chemical analysis.

A soil blend formula was developed with Rutgers based on their evaluation of the decontaminated sediment. The decontaminated sediment was a silty loam with elevated soluble salt and very little organic matter and nutrients. The soil blend formula was developed to provide structure (sand), the proper grain size distribution, and organic matter. The topsoil was manufactured by blending 39.3% decontaminated sediment (by dry weight), 42.6% sand, 12.3% organics (peat moss), and 5.8% red clay. Between December 15 and 19, 2008, the 20 cy of decontaminated sediment was blended into manufactured topsoil at MSU. With the approval of the NJDEP, the manufactured topsoil was used to create an interpretative walk at MSU's Mallory Hall as part of their Passaic River Initiative. Presented below, in Table 4-8 is a summary of the chemical analyses of the additives

Table 4-8 Analytical Results for Manufactured Soil Additives

Chemical Analysis	NJRDCSRS	AD1 (Sand)	AD2 (Red Clay)	AD3 (Peat Moss)
Total Organic Carbon (mg/kg)	-	51,900	237 J	420,000
Dioxins/Furans (pg/g)				
2,3,7,8-TCDD	-	ND (<1.0)	ND (<1.0)	ND (<4.4)
TCDD/TCDF TEV	-	0.0	0.0	0.0
Total PCBs (µg/kg)¹	200	0.0	0.0	0.0
Polynuclear Aromatic Hydrocarbons (µg/kg)				
Anthracene	17,000,000	ND (<17)	ND (<17)	ND (<230)
Benzo(a)anthracene	600	ND (3.5)	ND (<3.5)	ND (<49)
Benzo(a)pyrene	200	ND (3.5)	ND (<3.5)	ND (<49)
Benzo(b)fluoranthene	600	ND (3.5)	ND (<3.5)	ND (<49)
Chrysene	62,000	ND (3.5)	ND (<3.5)	ND (<49)
Dibenz(a,h)anthracene	200	ND (3.5)	ND (<3.5)	ND (<49)
Fluoranthene	2,300,00	ND (3.5)	0.62 J	ND (<49)
Metals (mg/kg)				
Arsenic	19	4.6	4.7	ND (<0.73)
Cadmium	78	0.18 J	ND (<0.52)	0.86
Total Chromium	-	6.4	20.9	0.28 J
Lead	400	4.4	7.8	2.5
Mercury	23	ND (<0.017)	0.016 J	0.036
Nickel	1,600	7.1	51.4	0.35 J
Silver	390	ND (<0.26)	ND (<0.26)	ND (<0.37)
Zinc	23,000	39.5	72.5	8.1
Metals - TCLP (mg/L)				
Arsenic	-	ND (<0.50)	ND (<0.50)	ND (<0.50)
Barium	-	0.65 J	0.34 J	0.017 J
Cadmium	-	0.0014 J	ND (<0.10)	ND (<0.10)
Total Chromium	-	0.0014 J	0.0018 J	0.0025 J
Lead	-	ND (<0.50)	ND (<0.50)	ND (<0.50)
Mercury	-	ND (<0.0002)	ND (<0.0002)	ND (<0.0002)
Selenium	-	ND (<0.025)	ND (<0.025)	ND (<0.025)
Silver	-	ND (<0.50)	ND (<0.50)	ND (<0.50)
Grain Size Distribution				
Sand (> 0.075 mm)	-	90.8%	2.1%	93.4%
Silt (0.002 to 0.075 mm)	-	6.7%	73.3%	6.6%
Clay (<0.002 mm)	-	2.5%	24.6%	0.0%

Bold indicates concentrations above the NJRDCSRS

¹ Total Polychlorinated Biphenyls are a sum of the individual PCB congeners.

J = Estimated value

ND = Not detected above the detection limit shown

used in making the topsoil. All concentrations of potential contaminants were below the NJRDCSRS.

Presented below, in Table 4-9, is a summary of the results of the soil testing performed by Rutgers. The results indicate the manufactured soil has adequate, if not abundant, macro and micronutrients. The sandy loam texture is ideal for topsoil. The pH is within the optimum range for most plants, and the organic matter is sufficient. The electrical conductivity is a measure of the cations in the soil, or soluble salts, and an analysis of the cations in the decontaminated sediment showed they were primarily calcium and magnesium, not sodium, which should not inhibit plant growth.

Table 4-9 Manufactured Soil Testing Results

Analysis	Optimum Range	Decontaminated Sediment	Manufactured Topsoil
Texture	-	Silty Loam	Sandy Loam
pH	6.0 – 6.8	4.32	6.15
Electrical Conductivity (mmho/cm)	0.5 – 1.0	3.62	1.43
Organic Matter	1.5 – 10%	4.24%	11.74%
Macronutrients¹ (pounds/acre)			
Phosphorus	72 – 137	57	138
Potassium	146 – 277	763	552
Magnesium	144 – 295	1,829	421
Calcium	1,401 – 1,790	5,703	1,942
Micronutrients¹ (parts per million)			
Zinc	1.0 – 50	84	6.1
Copper	0.5 – 20	39	2.5
Manganese	25 – 100	196	32
Boron	0.5 – 20	4.4	0.6
Iron	50 – 100	570	123

¹ Nutrients reported are measured as available to plants

Samples of the manufactured topsoil were analyzed for chemical constituents for comparison to the NJRDCSRS. Presented in Table 4-10 is a summary of the chemical analyses of the manufactured soil compared to the NJRDCSRS and the average chemical concentrations of the untreated sediment from the Lower Passaic River.

Table 4-10 Manufactured Soil Analytical Results

Chemical Analysis	NJRDCSRS	Untreated Sediment (average)	Manufactured Topsoil
Total Organic Carbon (mg/kg)	-	61,460	152,000
Dioxins/Furans (pg/g)			
2,3,7,8-TCDD	-	651.4	14.0
TCDD/TCDF TEV	-	751.4	22.1
Total PCBs (µg/kg)¹	200	463.8	72.3
Polynuclear Aromatic Hydrocarbons (µg/kg)			
Anthracene	17,000,000	700	23
Benzo(a)anthracene	600	1,688	82
Benzo(a)pyrene	200	1,732	81
Benzo(b)fluoranthene	600	2,041	100
Chrysene	62,000	2,035	<21
Dibenz(a,h)anthracene	200	316	<21
Fluoranthene	2,300,00	3,047	130
Metals (mg/kg)			
Arsenic	19	13.4	8.9
Cadmium	78	6.6	0.50
Total Chromium	-	191	37.9
Lead	400	376	34.0
Mercury	23	4.9	0.46
Nickel	1,600	50.0	27.4
Silver	390	6.4	0.45
Zinc	23,000	660	77.1
Metals - TCLP (mg/L)			
Arsenic	-	-	<0.50
Barium	-	-	0.21
Cadmium	-	-	0.0077
Total Chromium	-	-	0.0019
Lead	-	-	<0.50
Mercury	-	-	<0.00020
Selenium	-	-	<0.25
Silver	-	-	<0.50
Grain Size Distribution			
Sand (> 0.075 mm)	-	28.8%	68.2%
Silt (0.002 to 0.075 mm)	-	53.0%	25.3%
Clay (<0.002 mm)	-	18.2%	6.5%

Bold indicates concentrations above the NJRDCSRS

¹ Total Polychlorinated Biphenyls are a sum of the individual PCB congeners.

The analytical results for the chemical constituents showed no concentrations above the NJRDCSRS. In addition, a Toxicity Characteristic Leaching Procedure (TCLP) analysis showed the manufactured soil will not leach the residual concentrations of metals. Presented in Figures 4-19, and 4-20, and 4-21 are graphical representations of the analytical results for select contaminants for samples of the untreated sediment, the treated sediment, and the manufactured soil.

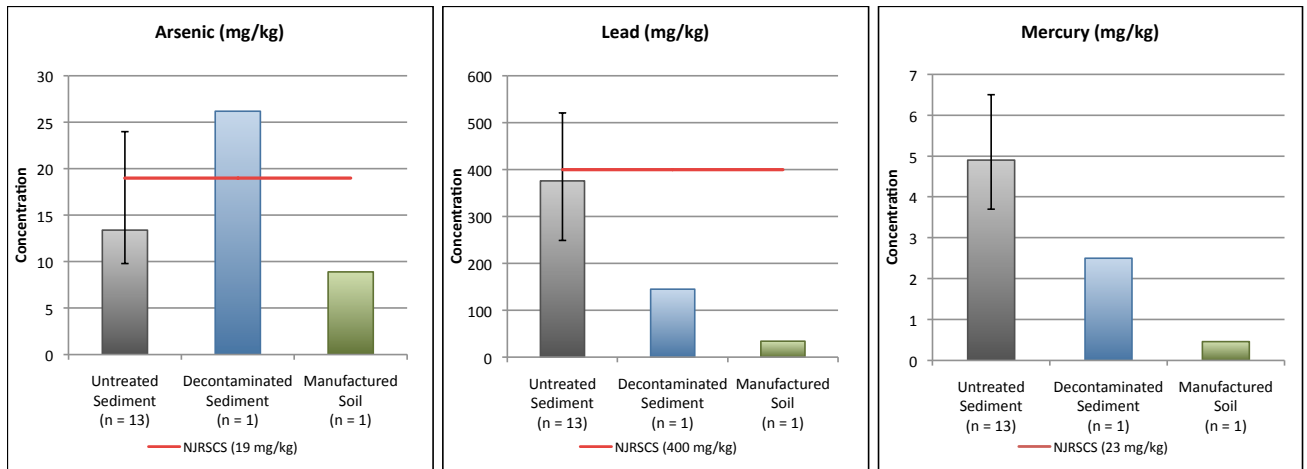

Figure 4-19 Analytical Results for Metals – Manufactured Soil

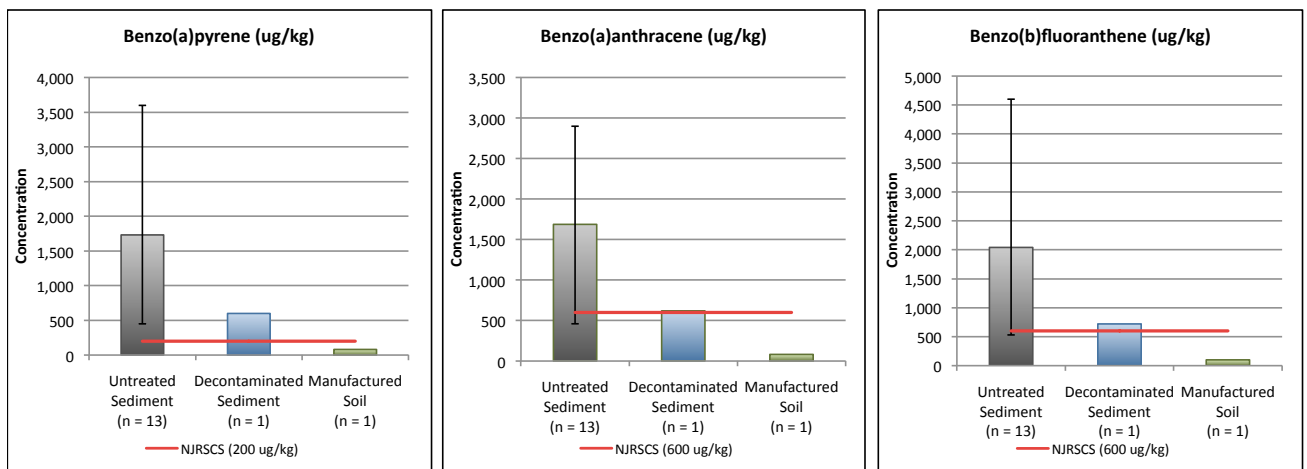

Figure 4-20 Analytical Results for PAHs – Manufactured Soil

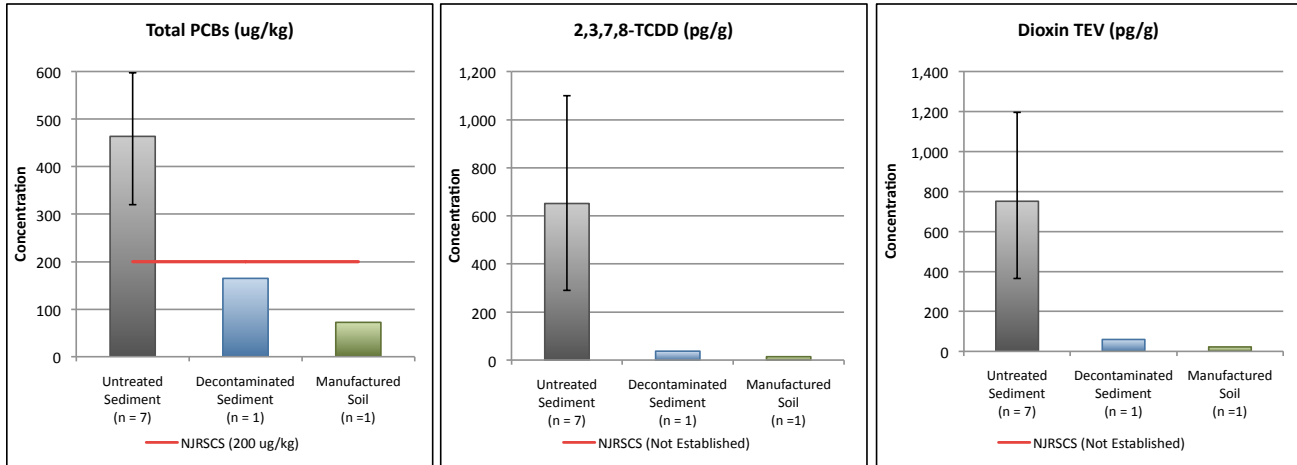

Figure 4-21 Analytical Results for PCBs and Dioxins – Manufactured Soil

4.4 Fate of Contaminants

The BioGenesisSM Sediment Decontamination Technology uses chemical and physical forces to remove organic and inorganic contamination from coarse- and fine-grained sediment. During the process, naturally occurring organic matter is fractionated and dislodged from the sediment matrix. Organic and inorganic contaminants adsorbed to the sediment particles are removed in the BioGenesisTM Collision Chamber. Solid/liquid separation techniques are used to recover the decontaminated sediment particles from the wastewater that contains the organic and inorganic contaminants and the naturally occurring organic matter. The data collection program developed for the full-scale demonstration project was designed to evaluate the level of residual contaminants in the decontaminated sediment for comparison to residential soil standards. Data was not collected to be able to perform mass balance calculations and show the fate of contaminants through the process because this was studied previously under the 1999 Pilot Demonstration Project performed in Kearny, NJ.

During the 1999 Pilot Demonstration Project, the BioGenesisSM Sediment Decontamination Process was operated in batch mode and data was collected to study the effectiveness of individual process components and evaluate the fate of contaminants through the process. The inputs and outputs from each batch process

during the validation test runs were measured and sampled. Mass balance calculations were performed to track certain inorganic and organic contaminants through the system. The results of this testing are described in detail in the 1999 Pilot Demonstration Report (WESTON, 1999), and are discussed in the following paragraphs.

The BioGenesisSM Sediment Decontamination Technology has evolved through the years, and at the time of the 1999 Pilot Demonstration Project the solid/liquid separation step consisted primarily of a low-speed, horizontal bowl centrifuge. Hydrocyclones were used at first during the pilot project to ensure no large particles were passed to the centrifuge, however the homogeneity of the grain size distribution in the batch of sediment processed during the pilot project provided a consistent fine-grained material to the system and the hydrocyclones were removed from the process in the validation test runs. The low-speed centrifuge captured only about 68% of the solids meaning that approximately 32% of the solids fed to the process were discharged in the centrate and sent to the wastewater treatment system.

Several improvements have been made to the solid/liquid separation step for the full-scale demonstration project which resulted in an estimated >90% recovery of solids into the treated sediment. These improvements include a scalping screen installed to remove coarse-grained sediment particles (sample location TS1) where approximately 5 to 20% of the solid particles were recovered. Hydrocyclones over dewatering screens were then used to recover fine sand and silt (sample location TS2) and recovered approximately 15 to 20% of the solid particles. Finally, a high-speed, horizontal bowl centrifuge was used to recover silt and clay (sample location TS3) and recovered approximately 30 to 60% of the solid particles. An estimate of 5 to 10% of the fine clay particles was sent to the water treatment system where the second centrifuge (sample location WS1) and the filter press (sample location WS2) removed these solids and produced the wastewater treatment sludge. Since the BioGenesisSM Sediment Decontamination process was operated in a continuous mode during the full-scale demonstration project, actual measurements of the mass

distribution of solids in the treated sediment and the wastewater treatment sludge were not made. These estimates are based on observations, percent moisture data, equipment performance criteria (screen sizes, cut points, etc.) and the grain size distribution in the untreated sediment.

In order to evaluate the fate of contaminants through the BioGenesisSM Sediment Decontamination Technology, the mass balance results from the 1999 Pilot Demonstration Project are summarized in Table 4-11. Samples were collected during the pilot project of the untreated raw sediment influent, the treated sediment, and the centrate from the centrifuge. The total mass of solids and liquids was determined for each batch at these sample locations. The slurry samples of the untreated sediment and the centrifuge centrate were separated into solid and liquid fractions using a high-speed, vertical-bowl, bench-top centrifuge, and the fractions were analyzed separately to study the distribution of contaminants at these locations in the process.

The mass balance calculations from the 1999 Pilot Demonstration give some insight into the distribution of contaminants in the BioGenesisSM Sediment Decontamination Technology evaluated in the full-scale demonstration project even though the solid/liquid separation process has been improved. First, mass balance calculations for inorganic compounds, with the exception of mercury, showed very little loss of mass in the calculation. This is expected and indicates the mass balance calculations are reasonable and plausible. The exception to this is mercury where approximately 40% of the mass was lost in the mass balance, which was hypothesized at the time to be from volatilization of the mercury.

The second observation is a partitioning of the heavy metals into the aqueous phase that is present in the untreated sediment and the centrate. Improvements in the use of chelants and solid/liquid separation techniques in the current process have not inversely impacted the concentration of heavy metals in the treated sediment even though a significantly higher percentage of finer grained material was recovered.

Table 4-11 Summary of Mass Balance Results from the 1999 Pilot Demonstration Project

	Untreated Sediment			Treated Sediment	Centrate		Difference
	Slurry Sample	Solid Fraction	Liquid Fraction		Solid Fraction	Liquid Fraction	
Arsenic¹							
Concentration	11.4 mg/kg	12.3 mg/kg	561 µg/L	7.8 mg/kg	24.2 mg/kg	95.1 µg/L	-
Mass	31,077 mg	28,460 mg	2,617 mg	12,274 mg	18,051 mg	1,087 mg	+405 mg / +1.3 %
Lead							
Concentration	136.9 mg/kg	157 mg/kg	9,080 µg/L	67.9 mg/kg	346 mg/kg	1,770 µg/L	-
Mass	404,854 mg	362,500 mg	42,353 mg	106,444 mg	258,441 mg	21,027 mg	-18,942 mg / -4.7%
Mercury							
Concentration	3.13 mg/kg	3.9 mg/kg	223 µg/L	0.3 mg/kg	7.0 mg/kg	28.6 µg/L	-
Mass	10,063 mg	9,024 mg	1,039 mg	465 mg	5,253 mg	340 mg	-4,004 mg / -39.8 %
Benzo(a)pyrene							
Concentration	<330 µg/kg	2,433 µg/kg	7 µg/L	1,633 µg/kg	850 µg/kg	5 µg/L	-
Mass	5,661 mg	5,630 mg	31 mg	2,559 mg	635 mg	59 mg	-2,408 mg / -42.5 %
Benzo(a)anthracene¹							
Concentration	<330 µg/kg	2,433 µg/kg	6 µg/L	1,600 µg/kg	1,433 µg/kg	5 µg/L	-
Mass	5,657 mg	5,630 mg	26 mg	2,507 mg	1,071 mg	59 mg	-2,020 mg / -35.7 %
Dibenz(a,h)anthracene¹							
Concentration	<330 µg/kg	633 µg/kg	7 µg/L	467 µg/kg	667 µg/kg	5 µg/L	-
Mass	1,497 mg	1,465 mg	31 mg	731 mg	498 mg	59 mg	-209 mg / -14.0 %
Total PCBs (Sum of Aroclors)¹							
Concentration	26 µg/kg	517 µg/kg	1 µg/L	203 µg/kg	1,470 µg/kg	1 µg/L	-
Mass	1,202 mg	1,195 mg	7 mg	319 mg	1,098 mg	6 mg	+221 mg / +18.4 %
2,3,7,8-TCDD¹							
Concentration	39.0 pg/g	91.3 pg/g	7.63 pg/L	56.7 pg/g	82 pg/g	604 pg/L	-
Mass	0.247 mg	0.211 mg	0.036 mg	0.089 mg	0.061 mg	0.007 mg	-0.090 mg / -36.4 %
Dioxin TEV							
Concentration	129 pg/g	128.0 pg/g	11,697 pg/L	82.7 pg/g	119.4 pg/g	935 pg/g	-
Mass	0.351 mg	0.296 mg	0.055 mg	0.130 mg	0.089 mg	0.011 mg	-0.121 mg / -34.4 %

¹ Mass balance calculations for these compounds were not included in the 1999 Pilot Demonstration Project Report. They were calculated using the data and approach used in the 1999 Pilot Demonstration Project Report.

Third, the chemical analysis of the solid fraction of the untreated sediment showed higher concentrations than the analysis of the total untreated sediment in some cases. This is most likely due to limitations in the analytical extraction methods for sediments with an elevated water content compared to the analytical extraction methods for solids with low water contents.

Finally, it appears that the organics did not partition to the aqueous fraction of the centrate in the 1999 Pilot Demonstration mass balance data. There is however, an overall reduction in the total mass of the organics ranging from 14 to 43%. This is not the same as percent reduction in the treatment of the sediment since it represents the sum of organics in both output streams (treated sediment and centrate to the wastewater treatment facility) compared to the input mass of organics in the untreated sediment. The mass reduction is important, however, because it is the result of the oxidation process that occurs in the BioGenesis™ Cavitation/Oxidation unit. Oxidation of the organics primarily occurs in the aqueous fraction due to the availability of the organics to the oxidant as compared to availability the organics adsorbed to the surface of the sediment particles to the oxidant.

In discussing the fate of contaminants in the sediment through out the BioGenesisSM Sediment Decontamination Process it is important to evaluate all of the inputs and outputs of the system. In addition to the untreated sediment slurry (sample location RS), potable city water and specialty washing chemicals were added to the process. No specific analytical samples of the potable city water were collected during the project, however there should be little or no increase in the concentration of contaminants from the use of potable city water since it can be expected that the water would meet drinking water standards and have no significant levels of these contaminants.

The following proprietary washing chemicals and standard commercially available water treatment chemicals were added to the sediment in the BioGenesisSM Sediment Decontamination Process during the full-scale demonstration project:

- BG-Clean S-19 – Chelant for soil and sediment decontamination
- BG-Clean S-20 – Chelant for soil and sediment decontamination
- BG-Clean S-29 – Surfactant for soil and sediment decontamination
- BG-Clean S-49 – Surfactant for soil and sediment decontamination
- Hydrogen Peroxide 35% – Oxidant
- Foam Ban MS-455 – Antifoam/defoamer

BioGenesis blends the proprietary washing chemicals for soil and sediment decontamination and the components of these chemicals are classified as trade secrets. However, none of the components used in the blending of the BioGenesis proprietary washing chemicals are listed on the USEPA Target Analyte List and would add to the concentration of contaminants in the treated sediment.

5 COMMERCIAL-SCALE SYSTEM RECOMMENDATIONS

5.1 Design Improvements

Based on observations made during the demonstration test, a few changes are recommended to the non-proprietary process equipment and parts of the system layout. Most of the recommended changes are to the material handling aspect of the system. A commercial-scale treatment operation would require a much more efficient front-end storage system for offloading, screening, and transferring the sediment. A permanent Upfront Storage Facility with tanks and agitators that could keep the sediment suspended, and sloped sides to allow sediment to move toward the withdrawal point, is recommended. A floating storage facility such as the one used during the demonstration test is not recommended for a permanent facility.

The offloading equipment should be sized for a minimum of 1,000 cy per shift. The offloading equipment may be more efficient if the material was pumped directly out of the barge to the screening plant. If a clamshell bucket is used, the primary screen would have to be equipped with a loading hopper on top of the screen to ease loading and minimize spillage, and a sloped hopper under the screen equipped with a mixer to provide good sediment agitation and a consistent feed to the pump allowing for more efficient pumping to the Upfront Storage Facility.

A commercial-scale system would have redundant piping and pumping systems that would allow the system to operate while one component was serviced or repaired. Better mixing tanks with coned bottoms would be used in all portions of the process where suspended solids existed. Chemical addition would be done in locations that enhance mixing, such as upstream of pumps, or high-energy mixers would be used to completely homogenize the chemicals into the process. Chemical storage would be in bulk tanks to minimize cost and storage space. Chemical storage, offloading and pumping equipment would be located in one area of the plant to manage inventory, handle spills, and allow efficient operational changes.

In a commercial-scale facility, solid/liquid separation would include micro-flotation to remove organics prior to hydrocyclones and centrifuges for recovery of solids for beneficial use. Even though navigational dredged material typically has little or no concentrations of VOCs, there is a potential for emissions of SVOCs from the sediment slurry in the micro-flotation unit. It is expected that off-gas control equipment will be needed for the micro-flotation unit, and that an air permit may be required.

The material handling system for solids separated from the slurry would be constructed primarily using conveyors to prevent the need for moving loads around the site in trucks.

The other issue encountered during the demonstration test was the wear that occurred in the pumps that were not rubber lined. Appropriate pumps will need to be used to minimize the maintenance requirements for all the pumps.

5.2 Site Selection

The site for a commercial-scale BioGenesis sediment decontamination facility would need to be located in the NY/NJ Harbor to minimize transport costs from the dredging sites to the treatment facility. The site will need deepwater barge access for the delivery and offloading of the dredged material. In order to accommodate upfront storage and storage of treated sediment and beneficial use products, a minimum of 25 acres will be required for a 40 cy per hour facility (nominally 250,000 cy/year) and possibly as much as 35 acres for a 80 cy/hr facility (nominally 500,000 cy/year). Ideally, the site would have railroad access for transport of the beneficial use products, but at a minimum, the site should have adequate access to truck traffic.

The commercial-scale treatment facility will be housed in a process building so that it can be operated all year long. The building will be approximately 350 ft by 100 ft for a 40 cy/hr facility and 350 ft by 150 ft for an 80 cy/hr facility. A minimum of 25 ft of clear span is recommended.

5.3 Projected Commercial-Scale Costs

This technology demonstration project was developed to help determine what a commercial-scale facility would cost to operate continuously on typical NY/NJ Harbor navigational dredged material. This demonstration provided valuable input about operating labor, material costs, utility consumption rates, and logistical considerations that must be addressed in a commercial-scale plant. Permanent operational costs were derived from the day-to-day cost and labor tracking data gathered during the demonstration test.

Presented in Table 5-1 is a summary breakdown of the capital and annual operating costs for both a 40 cy/hour and 80 cy/hour facility. The annual operational costs have been broken into “Annual Overhead Costs” and “Annual Operational Costs”. Overhead Costs represent indirect costs that are incurred independent of operations, and Operating Costs are costs that are directly related to the facility production. The Annual Operating Costs are based on operating the full-scale plant 24 hours per day 365 days per year. For costing purposes, the plant is assumed to operate at an 80% availability rate with scheduled maintenance and repairs within that time. The costs represent a total “tipping cost” for the decontamination and beneficial use of typical navigational dredged material (maintenance dredged material) from NY/NJ Harbor, from the offloading of the sediment from the delivery barges to the marketing and beneficial use of the manufactured soil. For this cost estimate, there has been a zero dollar value assigned to the sale of the manufactured soil. The level of contaminants in the dredged material can have an impact on the operational costs, specifically when concentrations of contaminants are orders of magnitude higher than the typical range for the NY/NJ Harbor navigational dredged material (see Table 3-1). Costs for decontamination of these materials will need to be evaluated on a case-by-case basis.

Table 5-1 Estimated Capital and Operating Costs for a Commercial-Scale BioGenesis Sediment Decontamination Facility

Capital Costs	40 cy/hour Facility (Nominally 250,000 cy/yr)	80 cy/hour Facility (Nominally 500,000 cy/yr)
Screening Facilities	\$ 174,000	\$ 261,000
Upfront Storage	475,000	925,000
Preprocessor Facilities	175,800	351,600
Water Blasters	381,000	631,000
Aeration/Micro-floatation Facilities	257,500	515,000
Collision Chamber Facilities	544,800	1,006,800
Cavitation/Oxidation Facilities	400,800	620,800
Hydrocyclone Facilities	367,000	722,000
Centrifuge Facilities	1,200,000	2,000,000
Filter Presses	1,000,000	1,500,000
Wastewater Equalization	90,800	100,800
Flocculation/Clarification	120,000	225,000
Initial pH Adjustment	27,000	37,000
Filtration Facilities	140,000	270,000
Organics Removal	160,000	310,000
Final pH Adjustment	27,000	37,000
Sludge Processing	64,000	115,000
Chemical Feed Systems	304,960	586,360
Treated Sediment Storage	216,000	401,000
Plant Utility Water	16,000	16,000
Passive Vapor Phase Treatment	2,500	2,500
Plant Air Compressor	<u>15,000</u>	<u>30,000</u>
Equipment Capital Cost	\$ 6,159,160	\$ 10,663,860
Equipment Installation (15%)	923,874	1,599,579
Mechanical (20%)	1,231,832	2,132,772
Electrical and Instrumentation (20%)	<u>1,231,832</u>	<u>2,132,772</u>
Installation Cost	\$ 3,387,538	\$ 5,865,123
Yard Piping	97,000	121,250
Process Building	2,000,000	2,500,000
Site Preparation	<u>750,000</u>	<u>937,500</u>
Subtotal Capital Costs	\$ 12,393,698	\$ 20,087,733
Contingency (15%)	<u>1,859,055</u>	<u>3,013,160</u>
Total Capital Costs	\$ 14,252,753	\$ 23,100,893

Table 5-1 Estimated Capital and Operating Costs for a Commercial-Scale BioGenesis Sediment Decontamination Facility (continued)

Annual Costs	40 cy/hour Facility (Nominally 250,000 cy/yr)	80 cy/hour Facility (Nominally 500,000 cy/yr)
Annual Overhead Costs		
Labor	\$ 356,200	\$ 356,200
Utilities	6,000	9,000
Waste Disposal	6,000	9,000
Office Supplies/Equipment	18,000	27,000
Site Lease	2,100,000	2,940,000
Building Maintenance (5% of Capital Cost)	100,000	125,000
Site Maintenance (5% of Capital Cost)	<u>37,500</u>	<u>46,875</u>
Total Annual Overhead Costs	\$ 2,623,700	\$ 3,513,075
Annual Operating Costs		
Labor	\$ 3,559,440	\$ 5,521,952
Power	1,681,920	3,363,840
Water	235,469	470,938
Wastewater Disposal	264,902	529,805
Solids Disposal	1,497,960	2,995,920
Solid Waste Disposal	43,800	87,600
Chemical Usage	3,924,480	7,848,960
Equipment Maintenance (20% of Capital Cost)	<u>1,231,832</u>	<u>2,132,772</u>
Total Annual Overhead Costs	\$ 12,439,803	\$ 22,951,786
Unit Costs		
Annual Volume	280,320 cy	560,640 cy
Overhead Costs	\$ 2,623,700	\$ 3,513,075
Operating Costs	12,439,803	22,951,786
Annual Capital Costs (10 year payback)	<u>1,425,275</u>	<u>2,310,089</u>
Unit Cost	\$ 58.82/cy	\$ 51.33/cy

Assumptions:

- Labor force includes 13 workers on 1st shift, and 10 workers on 2nd and 3rd shifts for 250,000 cy/yr facility.
- Management labor includes 5 people on day shift and 1 supervisor on 2nd and 3rd shifts for 250,000 cy/yr facility.
- Power costs based on \$0.08 per kW-hr.
- Plant operations assumed to be 24 hours/day, 365 days/year at 80% average uptime.
- Water costs based on \$0.0035 per gallon.
- Wastewater Disposal costs based on \$0.003 per gallon.
- Chemicals costs based on \$14.00 per cy (includes washing chemicals and wastewater treatment chemicals).
- Waste disposal costs based on \$150 per ton for hazardous wastes and \$75 per ton for non-hazardous wastes.
- Site Lease costs at \$7,000 per month per acre including waterfront facilities.
- No product recovery value included in the unit costs.

6 CONCLUSIONS AND RECOMMENDATIONS

6.1 Conclusions

6.1.1 Process Verification to Meet New Jersey Soil Remediation Standards

Analytical tests on the treated sediment from the three different dredged material sites demonstrated significant reductions in dioxins, PCBs, and all heavy metals except arsenic. Some contaminants were readily removed and others, such as PAHs, were difficult to remove. However, we have concluded that the BioGenesisSM Sediment Decontamination Process can be adjusted to treat maintenance dredged material to meet the NJRDCSRS with the exception of naturally occurring heavy metals such as arsenic. Arsenic and PAHs are discussed below.

Demonstration analytical results show that the BioGenesis process had limited success in removing arsenic from the dredged material, particularly from dredged material from the Raritan River. Based on the untreated sediment analytical data and on the fact that the concentration of other metals were reduced effectively in the process, we have concluded that the arsenic species found in the sediment is recalcitrant, due to the fact that the arsenic is embedded in the mineral matrix of the sediment particles. Research sponsored by the NJDEP, Division of Science, Research, and Technology, documents the ambient levels of total arsenic in New Jersey coastal plain soils range from 3 to 131 mg/kg, with a median of 30 mg/kg (NJDEP, 2001). These values are consistent with the arsenic levels in the sediments treated during the demonstration project, particularly those from the Raritan River, and lead to the conclusion that the arsenic was bound in the mineral matrix of the sediment particles and thus un-extractable.

During the demonstration, PAHs were difficult to remove from the sediment from the Lower Passaic River and Arthur Kill. Treated sediment subsamples TS1, TS2, and TS3 had progressively finer particle matrices due to their locations in the solid/liquid removal process, and analytical data from these samples showed that

the concentrations of PAHs in the coarser material were higher than the levels of PAHs in the finer grain material. This result is unexpected since the surface area per unit volume of the finer grain-sized particles is significantly higher than the surface area per unit volume of the larger grain-sized particles, and higher surface areas typically result in higher concentrations of adsorbed contaminants.

Extensive bench scale testing on Lower Passaic River sediment conducted in Milwaukee during January through May 2008 (see Section 4.3.5 of this report) confirmed that PAHs are absorbed in the organic detritus material mixed with the sediment. A separation step using micro-floatation is needed to remove the fine organic materials from the decontaminated sediment prior to solid/liquid separation. The capital cost and operational cost for this unit is included in the cost projections in Section 5 of this report.

6.1.2 Verification that Costs are Consistent with Current Prices for the Management of Contaminated Navigation Dredged Material

One of the goals for the demonstration project was to determine the cost per unit to treat the sediment and to determine whether such costs are consistent with current prices for the management of contaminated navigational dredged material. The cost per cubic yard for decontamination using the BioGenesisSM Sediment Decontamination Process in a commercial scale facility is presented in Table 5-1 in Section 5.3 of this report. This table shows the components that factored into the cost basis, with adjustments for economies of scale, permanently installed equipment, local labor, balanced utility rates, and other savings related to location and permitting. The costs shown in Table 5-1 are based on 2008 dollars and are affected by the local labor costs, and costs of utilities such as natural gas or heating oil, power, and water.

At commercial scale (500,000 cy/year) the cost to decontaminate sediment using the BioGenesisSM Sediment Decontamination Process is approximately \$51/cy. In order to determine the market value for decontaminating maintenance dredged material in the NY/NJ Harbor, BioGenesis reviewed bid prices to the USACE for

dredging and upland placement of dredged material in the NY/NJ Harbor for the past few years. Provided in Table 6-1 is a summary of the USACE projects in NY/NJ Harbor since 2005 where all the material was designated for upland placement were considered. These dredging projects are bid to the USACE as lump sum contracts and as such, a breakdown of the unit prices is not available. In order to compare these bid prices with the BioGenesis decontamination cost estimate, the bid prices were adjusted to account for the upper range of typical mobilization and demobilization costs, dredging costs, and costs for disposal of oversized debris. The estimate to decontaminate sediment using the BioGenesisSM Sediment Decontamination Process at approximately \$51/cy commercially is very competitive compared to the USACE contracts identified in Table 6-1.

Table 6-1 Summary of USACE Dredging Project Costs¹

Fiscal Year	Project	Bid Quantity	Bid Price	Adjusted Upland Placement Unit Price²
2005	NY&NJ Channels Arthur Kill	200,000 cy	\$ 15,922,301.50	\$ 55.86/cy
2006	Newark Bay Pt, Newark Pier	238,265 cy	\$ 23,535,270.00	\$ 75.63/cy
2007	NY&NJ Channels, Arthur Kill	66,000 cy	\$ 5,594,480.00	\$ 53.40/cy
2008	NY&NJ Chnl-Arth Kill	31,000 cy	\$ 10,402,540.00	\$ 291.37/cy
2008	Newark Bay, NJ	60,260 cy	\$ 26,792,635.00	\$ 412.17/cy
2008	Raritan River, NJ	27,525 cy	\$ 4,194,450.00	\$ 105.14/cy

¹ Source: USACE dredging database www.iwr.usace.army.mil/NDC/data/datadrg.htm, October 2009

² Unit Price calculated by subtracting \$750,000 for mobilization and demobilization, \$15.00/cy for dredging, and \$5.00/cy for disposal of oversized debris from the bid price and dividing by the bid quantity. These cost adjustments represent the upper range of typical dredging project costs in the NY/NJ Harbor per conversations with S. Douglas at the NJDOT.

6.2 Recommendations

6.2.1 Technology Assessment

The BioGenesisSM Sediment Decontamination Technology is ready for commercial application to process contaminated navigational dredged material. It can reliably decontaminate navigational dredged material to produce a manufactured soil for beneficial use.

6.2.2 Process Optimizations

Recalcitrant Metal Compounds – The use of a chelating agent during the demonstration test showed that the amount of metals in solution increased when the agent was being added to the slurry stream. Naturally occurring recalcitrant metals that are embedded in the mineral matrix of the sediment particles cannot be removed without dissolving the mineral matrix of the sediment. During full-scale operations, the nature of heavy metals which have been shown to be naturally occurring (such as arsenic) will need to be evaluated for each sediment source so that the treated material can meet New Jersey soil criteria.

Recalcitrant Organic Compounds – The full-scale BioGenesis sediment decontamination facility will need to incorporate micro-flotation in the solids/liquid separation step prior to the hydrocyclones and centrifuges to remove organic materials saturated with organic contaminants before recovery of the remaining solids for beneficial use.

Wastewater Treatment System – The wastewater treatment system should be designed with more than one process option. The demonstration test was done using a single clarifier and some filters. The full-scale system would have more operational flexibility to maintain discharge water quality standards if there were other treatment units. For example, use of a thickener would prevent overloading of the clarifier if one of the upstream solid/liquid separation units was upset. In addition, the system would benefit from better chemical mixing and blending in the

wastewater stream prior to flocculation and precipitation. This would require more tanks with integrated mixers and chemical addition systems.

Further wastewater system changes may involve the use of membranes or advanced filtration units to remove metals and organics as a final polishing step. The cost benefit of these steps would depend on the operating cost of carbon filters and sand filters, which were selected for this project based on their minimal operating cost.

7 REFERENCES

- BioGenesis, 1993 – *Final Report, Bench-Scale Studies of Thunder Bay Harbour Sediment, BioGenesisSM Sediment Washing Process*, BioGenesis Enterprises, Inc., August 1993, available at: www.biogenesis.com/ssebbs.html.
- BioGenesis, 1998 – *BioGenesisSM Technology Summary Report, Decontaminating Dredged Estuarine Sediments*, BioGenesis Enterprises, Inc., March 1993, available at: www.biogenesis.com/ssebbs.html.
- BioGenesis, 2002 – *Report of Ex-Situ Bench-Scale Treatability Testing of Sediments Using BioGenesisSM Sediment Washing Technology, Agreement No. CE 43/2000 (CE), South East Kowloon Development, Kai Tak Approach Channel Reclamation*, BioGenesis Enterprises, Inc., August 2002, available at: www.biogenesis.com/ssebbs.html.
- BioGenesis, March 2008 – *BioGenesisSM Sediment Washing Technology, Bench-Scale Treatability Study Report, Housatonic River – Rest-of-River Site*, BioGenesis Enterprises, Inc., March 2008, available at: www.biogenesis.com/ssebbs.html.
- BioGenesis, June 2008 – *BioGenesisSM Sediment Washing Technology, Bench-Scale Treatability Study Report, Housatonic River – Rest-of-River Site, Supplement to the Final Report of 13 March 2008*, BioGenesis Enterprises, Inc., June 2008, available at: www.biogenesis.com/ssebbs.html.
- BioGenesis, October 2008 – *Bench-Scale Treatability Study Report, BioGenesisSM Sediment Washing Technology, NamDong Retardation Basin, Incheon City, South Korea*, BioGenesis Enterprises, Inc., October 2008, available at: www.biogenesis.com/ssebbs.html.
- BioGenesis Italia, 2005 – *Technical Report, Pilot Scale Demonstration Project Of The BioGenesisSM Sediment Decontamination Process, Autorità Portuale di Venezia*, BioGenesis Italia, LLC., April 2005, available at: www.biogenesis.com/ssebbs.html.
- Environment Canada, 2000 – *Great Lakes 2000 Clean Up Fund, Contaminated Sediment Treatment Technology Program (CoSTTeP) Final Report*, Environment Canada, 2000, available at: www.biogenesis.com/ssebbs.html.
- NJDEP, 1999 – N.J.A.C. 7:26D – Soil Cleanup Criteria, May 12, 1999.
- NJDEP, 2001 – *Baseline Concentrations of Arsenic, Beryllium, and Associated Elements in Glauconite and Glauconitic Soils in the New Jersey Coastal Plain*, John H. Dooley, New Jersey Department of Environmental Protection, Division of Science, Research, and Technology, 2001.

- NJDEP, 2003 – *Ambient Levels of Metals in New Jersey Soils, Environmental Assessment and Risk Analysis Element Research Project Summary*, New Jersey Department of Environmental Protection, Division of Science, Research, and Technology May 2003.
- NJDEP, 2008 – N.J.A.C. 7:26D – Remediation Standards, June 2, 2008.
- NYDEC, 1994 – *Technical and Administrative Guidance Memorandum 4046: Determination of Soil Cleanup Objectives and Cleanup Levels*, New York Department of Environmental Conservation, www.dec.ny.gov/regulations/2612.html, January 1994.
- Yalkowsky, 2003 – *Handbook of Aqueous Solubility Data*, Samuel H Yalkowsky and Yan He, CRC Press, 2003.
- USACE, 2008 – *Dredged Material Management Plan for the Port of New York and New Jersey*, US Army Corps of Engineers, August 2008.
- USACE, 2009 – *USACE Navigation Data Center, U.S. Waterway Data, Dredging Information System, Dredging Contracts*, US Army Corps of Engineers, www.iwr.usace.army.mil/NDC/data/datadrg.htm.
- USEPA, 1993 – *BioGenesis™ Soil Washing Technology, Innovative Technology Evaluation Report*, USEPA Office of Research and Development, September 1993. EPA/540/R-93/510, available at: www.biogenesis.com/ssebbs.html.
- WESTON, 1999 – *Final Report on the Pilot Demonstration Project of the BioGenesisSM Sediment Washing Technology, Full-Scale, 40 cy/hr, Sediment Decontamination Facility, for the NY/NJ Harbor Region*, Roy F. Weston, Inc., December 1999, available at: www.biogenesis.com/ssebbs.html.
- Zhu, 2003 – *Molecular-Level Investigation of Monoaromatic Compound Sorption to Suspended Soil Particles by Deuterium Nuclear Magnetic Resonance*, Dongqiang Zhu, Bruce E. Herbert, and Mark A. Schlautman, J. Environ. Qual., Vol. 32, January-February 2003.



**Demonstration Testing and Full-Scale Operation of the
BioGenesis Sediment Decontamination Process
Appendix A Photos**



Keasbey Site - Prior to Mobilization

(clockwise from top left: Building Exterior, Waterfront Looking Downriver, Building Interior Looking Toward Waterfront, Building Interior Looking West)



Facility Construction

(clockwise from top left: Preprocessor Mix Tank T-102, Water Storage Tanks T-407 and T-409, BioGenesis Preprocessor and Cavitation/Oxidation Skids, BioGenesis Collision Chamber)



Power Supply
(clockwise from top: Main Generator, Secondary Generator, Transformer)

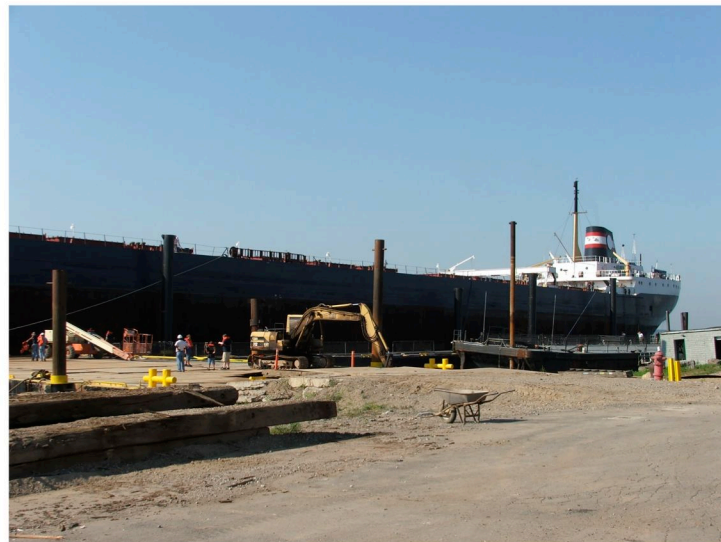

Upfront Storage System

(clockwise from top: Towing the Upfront Storage Facility to Keasbey, Stern of the Upfront Storage Facility Moored in Keasbey, Bow of the Upfront Storage Facility Moored in Keasbey)



Dredging of the Raritan River

(clockwise from top: View from the Upfront Storage Facility, View from Upland, River Survey Boat)



Dredging and Sediment Delivery

(clockwise from top left: Delivery of Raritan River Sediment, Dredging the Lower Passaic River, Delivery of Lower Passaic River Sediment, Delivery of Arthur Kill Sediment)

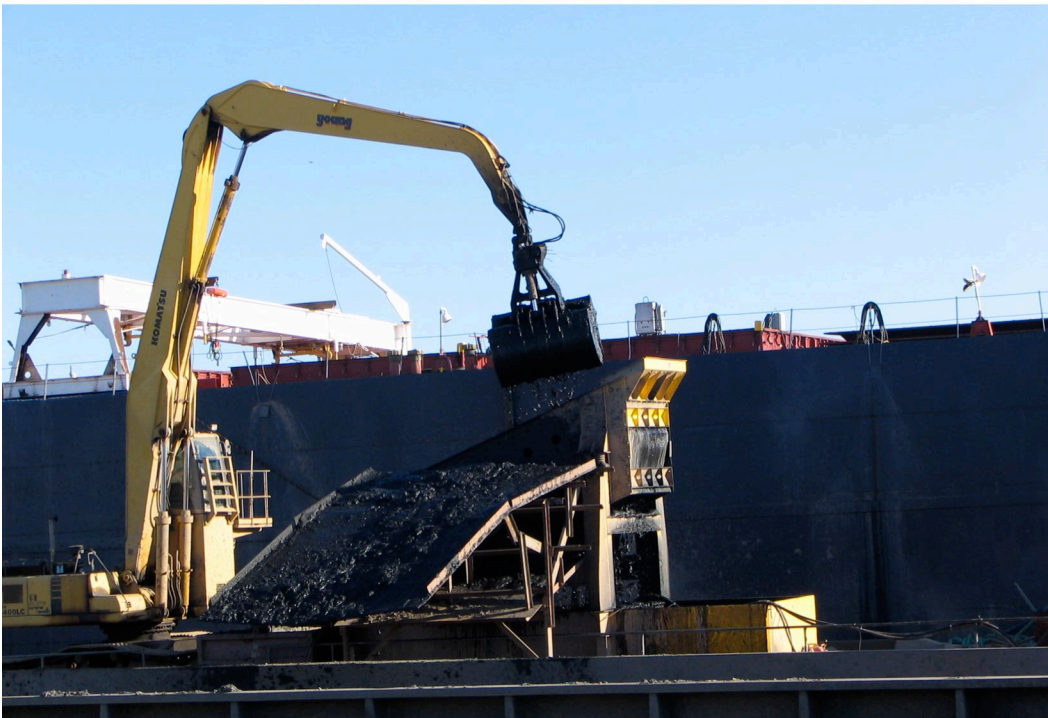

Offloading and Screening

(clockwise from top left: Oversized Debris, Sediment Scow in Offloading Slip, Offloading, Screening)

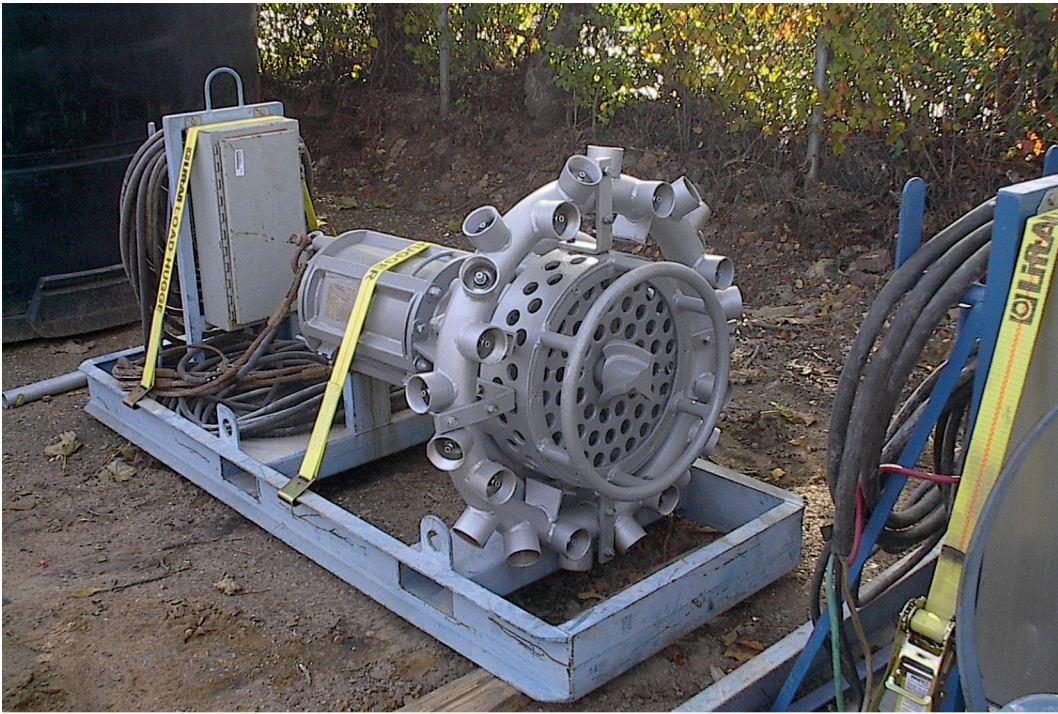

Submersible Pumps for Sediment Mixing and Transfer from Upfront Storage Facility
(clockwise from top left: 20 Hp Submersible Pump, Installation of 30 Hp Pump, Recirculation and Mixing of Sediment)



BioGenesis Preprocessor

(clockwise from top left: Side View of Preprocessor Skid, End View of Preprocessor Skid, 10,000 psi Water Blaster)

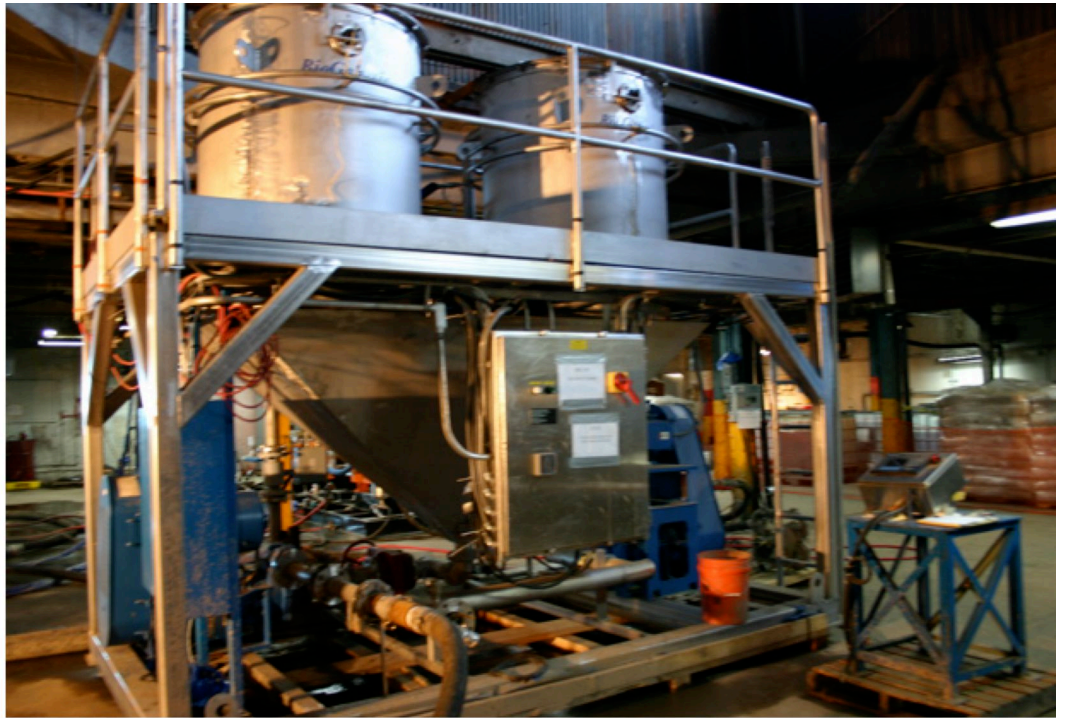

BioGenesis Collision Chamber

(clockwise from left: Operator at Control Panel, Collision Chamber Skid, 10,000 psi Water Blaster)

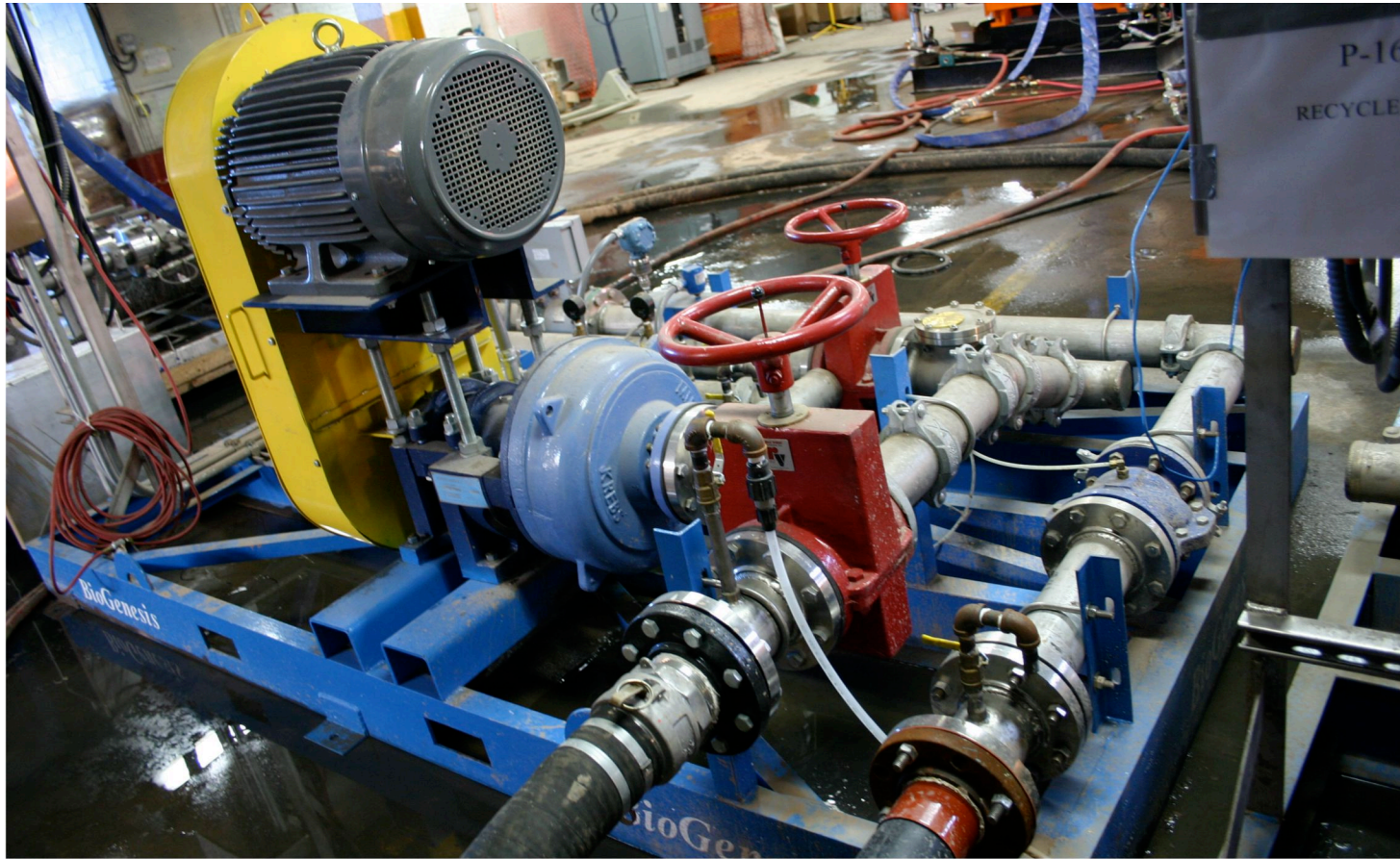

BioGenesis Cavitation/Oxidation Unit

(clockwise from top: Top View of Cavitation/Oxidation Skid, Back View of Skid, Front View of Skid)



Solid/Liquid Separation Equipment

(clockwise from top left: Hydrocyclones, Centrifuge One, Dewatering Unit, Decontaminated Sediment)



Decontaminated Sediment

(clockwise from top left: Collecting Material for Sample, Sampling, Stockpile Area, Stockpiled Decontaminated Sediment)



Wastewater Treatment Equipment
(clockwise from top: Centrifuge Two and Conveyor, Filter Press, Lime Addition Tank)



Wastewater Treatment Equipment
(clockwise from left: Clarifier, Sand Bed Filters, Carbon Filters)



Clean-out of Upfront Storage Facility
(clockwise from top: Loading Box with Residual Sediment, Lifting Box Overhead, Unloading Box into Scow, Pressure Washing Cargo Hold)



Pump Damage - No Rubber Lining
(clockwise from top left: P106 Impeller, P106 Volute, P102 Impeller, P102 Volute)



Blending Decontaminated Sediment into Topsoil

(clockwise from top left: Decontaminated Sediment, Stockpiled Manufactured Top Soil, Screening, Blending with Loader, Sand prior to Blending)

APPENDIX B
ANALYTICAL RESULTS SUMMARY TABLES

***DEMONSTRATION TESTING AND
FULL-SCALE OPERATION OF THE
BIOGENESISSM SEDIMENT DECONTAMINATION
PROCESS***

TABLE OF TABLES

Table 1	Volatile Organic Compounds Solid Sample Data Summary
Table 2	Semi-Volatile Organic Compounds Solid Sample Data Summary
Table 3	Polynuclear Aromatic Hydrocarbons Solid Sample Data Summary
Table 4	Pesticides Solid Sample Data Summary
Table 5	Herbicides Solid Sample Data Summary
Table 6	Polychlorinated Biphenyls (Aroclors) Solid Sample Data Summary
Table 7	Polychlorinated Biphenyls (Congeners) Solid Sample Data Summary
Table 8	Dioxins/Furans Solid Sample Data Summary
Table 9	Metals Solid Sample Data Summary
Table 10	Hexavalent Chromium Solid Sample Data Summary
Table 11	Mercury by EPA Method 245.5 Solid Sample Data Summary
Table 12	Cyanide Solid Sample Data Summary
Table 13	Total Organic Carbon Solid Sample Data Summary
Table 14	Oil and Grease Solid Sample Data Summary
Table 15	Percent Moisture/Solids Sample Data Summary
Table 16	Miscellaneous Solid Parameters Sample Data Summary
Table 17	Sieve Size Solid Sample Data Summary
Table 18	TCLP Volatile Organic Compounds Solid Sample Data Summary
Table 19	TCLP Semi-Volatile Organic Compounds Solid Sample Data Summary
Table 20	TCLP Metals Solid Sample Data Summary
Table 21	TCLP Herbicides Solid Sample Data Summary
Table 22	TCLP Pesticides Solid Sample Data Summary
Table 23	Volatile Organic Compounds Water Sample Data Summary
Table 24	EPA 625 Semi-Volatile Organic Compounds Water Sample Data Summary
Table 25	SW8270C Semi-Volatile Organic Compounds Water Sample Data Summary
Table 26	Polynuclear Aromatic Hydrocarbon Compounds Water Sample Data Summary
Table 27	EPA 608 Pesticides/Polychlorinated Biphenyls Water Sample Data Summary
Table 28	SW8081A Pesticides Water Sample Data Summary
Table 29	SW8082 Polychlorinated Biphenyls Water Sample Data Summary
Table 30	2,3,7,8-Tetrachlorodibenzo-p-Dioxin Water Sample Data Summary
Table 31	Dioxin/Furan Water Sample Data Summary
Table 32	EPA 200 Metals Water Sample Data Summary
Table 33	SW6010B Metals Water Sample Data Summary
Table 34	Water Quality Parameters Sample Data Summary

SOLIDS ANALYSES

TABLE 1

VOLATILE ORGANIC COMPOUNDS SOLID SAMPLE DATA SUMMARY
DEMONSTRATION TESTING AND FULL-SCALE OPERATION OF THE BIOGENESIS SEDIMENT DECONTAMINATION PROCESS
KEASBEY, NEW JERSEY
 (Page 1 of 2)

Field Sample Identification	PR-D-040107-1055	PR-C-040107-1035	PR-B-040107-0940	PR-A-040107-0905	SPC COMP-160506-1700	SPP COMP-170506-1030
Sediment Source	Lower Passaic River	Lower Passaic River	Lower Passaic River	Lower Passaic River	All	All
Location Identification	MSL	MSL	MSL	MSL	TSP	TSP
Date Collected	1/4/07	1/4/07	1/4/07	1/4/07	5/16/06	5/17/06
Matrix	Solid	Solid	Solid	Solid	Solid	Solid
Analyte/Methods (Units)						
Volatile Organic Compounds/SW8260B (µg/kg)						
1,1,1,2-Tetrachloroethane	<6.5	<6.4	<6.3	<6.2	<9.1	<7.1
1,1,1-Trichloroethane	<6.5	<6.4	<6.3	<6.2	<9.1	<7.1
1,1,2,2-Tetrachloroethane	<6.5	<6.4	<6.3	<6.2	<9.1	<7.1
1,1,2-Trichloro-1,2,2-trifluoroethane	<6.5	<6.4	<6.3	<6.2	-	-
1,1,2-Trichloroethane	<6.5	<6.4	<6.3	<6.2	<9.1 UJ	<7.1 UJ
1,1-Dichloroethane	<6.5	<6.4	<6.3	<6.2	<9.1	<7.1
1,1-Dichloroethene	<6.5	<6.4	<6.3	<6.2	<9.1	<7.1
1,2,4-Trichlorobenzene	<6.5	<6.4	<6.3	<6.2	-	-
1,2-Dibromo-3-chloropropane	<6.5	<6.4	<6.3	<6.2	-	-
1,2-Dibromoethane	<6.5	<6.4	<6.3	<6.2	-	-
1,2-Dichlorobenzene	<6.5	<6.4	<6.3	<6.2	-	-
1,2-Dichloroethane	<6.5	<6.4	<6.3	<6.2	<9.1	<7.1
1,2-Dichloropropane	<6.5	<6.4	<6.3	<6.2	<9.1	<7.1
1,3-Dichlorobenzene	<6.5	<6.4	<6.3	<6.2	-	-
1,4-Dichlorobenzene	<6.5	<6.4	<6.3	<6.2	-	-
2-Butanone (MEK)	<6.5	<6.4	<6.3	<6.2	<9.1 UJ	<7.1 UJ
2-Hexanone	<6.5	<6.4	<6.3	<6.2	-	-
4-Methyl-2-pentanone (MIBK)	<6.5	<6.4	<6.3	<6.2	<9.1	<7.1
Acetone	<26	<26	<25	<25	<37	<28
Acrylonitrile	<130	<130	<130	<120	<180	<140
Benzene	<6.5	<6.4	<6.3	<6.2	<9.1	<7.1
Bromodichloromethane	<6.5	<6.4	<6.3	<6.2	<9.1	<7.1
Bromoform	<6.5	<6.4	<6.3	<6.2	<9.1	<7.1
Bromomethane	<6.5	<6.4	<6.3	<6.2	<9.1	<7.1
Carbon disulfide	<6.5	<6.4	<6.3	<6.2	-	-
Carbon tetrachloride	<6.5	<6.4	<6.3	<6.2	<9.1	<7.1
Chlorobenzene	<6.5	<6.4	<6.3	<6.2	<9.1	<7.1
Chloroethane	<6.5	<6.4	<6.3	<6.2	-	-

TABLE 1

VOLATILE ORGANIC COMPOUNDS SOLID SAMPLE DATA SUMMARY
DEMONSTRATION TESTING AND FULL-SCALE OPERATION OF THE BIOGENESIS SEDIMENT DECONTAMINATION PROCESS
KEASBEY, NEW JERSEY
 (Page 2 of 2)

Field Sample Identification	PR-D-040107-1055	PR-C-040107-1035	PR-B-040107-0940	PR-A-040107-0905	SPC COMP-160506-1700	SPP COMP-170506-1030
Sediment Source	Lower Passaic River	Lower Passaic River	Lower Passaic River	Lower Passaic River	All	All
Location Identification	MSL	MSL	MSL	MSL	TSP	TSP
Date Collected	1/4/07	1/4/07	1/4/07	1/4/07	5/16/06	5/17/06
Matrix	Solid	Solid	Solid	Solid	Solid	Solid
Analyte/Methods (Units)						
Volatile Organic Compounds/SW8260B (µg/kg) (continued)						
Chloroform	<6.5	<6.4	<6.3	<6.2	<9.1	<7.1
Chloromethane	<6.5	<6.4	<6.3	<6.2	<9.1	<7.1
cis-1,2-Dichloroethylene	<6.5	<6.4	<6.3	<6.2	<9.1	<7.1
cis-1,3-Dichloropropene	<6.5	<6.4	<6.3	<6.2	<9.1	<7.1
Cyclohexane	<6.5	<6.4	<6.3	<6.2	-	-
Dibromochloromethane	<6.5	<6.4	<6.3	<6.2	<9.1	<7.1
Dichlorodifluoromethane	<6.5	<6.4	<6.3	<6.2	-	-
Ethylbenzene	<6.5	<6.4	<6.3	<6.2	<9.1	<7.1
Isopropylbenzene	<6.5	<6.4	<6.3	<6.2	-	-
Methyl acetate	<6.5	<6.4	<6.3	<6.2	-	-
Methylcyclohexane	<6.5	<6.4	<6.3	<6.2	-	-
Methylene chloride	2.4 T	2.0 T	2.6 T	2.1 T	18 J	3.6 TJ
Styrene	<6.5	<6.4	<6.3	<6.2	<9.1	<7.1
tert-Butyl methyl ether	<6.5	<6.4	<6.3	<6.2	-	-
Tetrachloroethylene (PCE)	<6.5	<6.4	<6.3	<6.2	<9.1	<7.1
Toluene	<6.5	<6.4	<6.3	<6.2	<9.1	<7.1
trans-1,2-Dichloroethene	<6.5	<6.4	<6.3	<6.2	<9.1	<7.1
trans-1,3-Dichloropropene	<6.5	<6.4	<6.3	<6.2	<9.1	<7.1
Trichloroethylene (TCE)	<6.5	<6.4	<6.3	<6.2	<9.1	<7.1
Trichlorofluoromethane	<6.5	<6.4	<6.3	<6.2	-	-
Vinyl chloride	<6.5	<6.4	<6.3	<6.2	<9.1	<7.1
Xylenes, Total	<19	<19	<19	<19	<27	<21

Bold Bolded result indicates positively identified compound.

- Not analyzed.

J Data are estimated due to associated quality control data.

T Analyte was positively identified but the reported concentration is estimated; reported concentration is less than the reporting limit, but greater than the method detection limit.

UJ Potential low bias, possible false negative.

TABLE 2

SEMI-VOLATILE ORGANIC COMPOUNDS SOLID SAMPLE DATA SUMMARY
DEMONSTRATION TESTING AND FULL-SCALE OPERATION OF THE BIOGENESIS SEDIMENT DECONTAMINATION PROCESS
KEASBEY, NEW JERSEY
 (Page 1 of 108)

Field Sample Identification	BAY-1	RS-211205-1000	TS-211205-1715	WS1-211205-1800	TS-291205-1100	WS-291205-1110
Sediment Source	Raritan River	Raritan River	Raritan River	Raritan River	Raritan River	Raritan River
Location Identification	PPS	RS	TS	WS	TS	WS
Date Collected	11/23/05	12/21/05	12/21/05	12/21/05	12/29/05	12/29/05
Matrix	Solid	Solid	Solid	Solid	Solid	Solid
Analyte/Methods (Units)						
Semi-Volatile Organic Compounds/SW8270C (µg/kg)						
1,2,4-Trichlorobenzene	-	-	-	-	-	-
1,2-Dichlorobenzene	-	-	-	-	-	-
1,2-Diphenylhydrazine	-	-	-	-	-	-
1,3-Dichlorobenzene	-	-	-	-	-	-
1,4-Dichlorobenzene	-	<910	<450 UJ	<1100	<960 D	<1100
1,4-Dioxane (p-Dioxane)	-	-	-	-	-	-
2,3,4,6-Tetrachlorophenol	-	-	-	-	-	-
2,3,5,6-Tetrachlorophenol	-	-	-	-	-	-
2,4,5-Trichlorophenol	-	<910	<450 UJ	<1100	<960 D	<1100
2,4,6-Trichlorophenol	-	<910	<450 UJ	<1100	<960 D	<1100
2,4-Dichlorophenol	-	-	-	-	-	-
2,4-Dimethyl phenol	-	-	-	-	-	-
2,4-Dinitrophenol	-	-	-	-	-	-
2,4-Dinitrotoluene	-	<910	<450 UJ	<1100	<960 D	<1100
2,6-Dichlorophenol	-	-	-	-	-	-
2,6-Dinitrotoluene	-	-	-	-	-	-
2-Aminonaphthalene	-	-	-	-	-	-
2-Chloronaphthalene	-	-	-	-	-	-
2-Chlorophenol	-	-	-	-	-	-
2-Methylnaphthalene	-	-	-	-	-	-
2-Methylphenol (o-Cresol)	-	<910	<450 UJ	<1100	<960 D	<1100
2-Nitroaniline	-	-	-	-	-	-
2-Nitrophenol	-	-	-	-	-	-
3,3'-Dichlorobenzidine	-	-	-	-	-	-
3-Nitroaniline	-	-	-	-	-	-

TABLE 2

SEMI-VOLATILE ORGANIC COMPOUNDS SOLID SAMPLE DATA SUMMARY
DEMONSTRATION TESTING AND FULL-SCALE OPERATION OF THE BIOGENESIS SEDIMENT DECONTAMINATION PROCESS
KEASBEY, NEW JERSEY
 (Page 2 of 108)

Field Sample Identification	BAY-1	RS-211205-1000	TS-211205-1715	WS1-211205-1800	TS-291205-1100	WS-291205-1110
Sediment Source	Raritan River	Raritan River	Raritan River	Raritan River	Raritan River	Raritan River
Location Identification	PPS	RS	TS	WS	TS	WS
Date Collected	11/23/05	12/21/05	12/21/05	12/21/05	12/29/05	12/29/05
Matrix	Solid	Solid	Solid	Solid	Solid	Solid
Analyte/Methods (Units)						
Semi-Volatile Organic Compounds/SW8270C (µg/kg) (continued)						
4,6-Dinitro-2-methylphenol	-	-	-	-	-	-
4-Bromophenyl phenyl ether	-	-	-	-	-	-
4-Chloro-3-methylphenol	-	-	-	-	-	-
4-Chloroaniline	-	-	-	-	-	-
4-Chlorophenyl phenyl ether	-	-	-	-	-	-
4-Methylphenol (p-Cresol)	-	-	-	-	-	-
4-Nitroaniline	-	-	-	-	-	-
4-Nitrophenol	-	-	-	-	-	-
Acenaphthene	<650	46 T	50 TJ	81 T	54 TD	<1100
Acenaphthylene	26 T	71 T	85 TJ	<1100	63 TD	<1100
Acetophenone	-	-	-	-	-	-
Aniline	-	-	-	-	-	-
Anthracene	78 T	190 T	200 TJ	290 T	190 TD	25 T
Atrazine	-	-	-	-	-	-
Benzaldehyde	-	-	-	-	-	-
Benzydine	-	-	-	-	-	-
Benzo(a)anthracene	190 T	330 T	490 J	330 T	460 TD	43 T
Benzo(a)pyrene	200 T	330 T	580 J	300 T	540 TD	<18
Benzo(b)fluoranthene	160 T	350 T	560 J	350 T	500 TD	<1100
Benzo(g,h,i)perylene	160 T	300 T	400 TJ	280 T	320 TD	<1100
Benzo(k)fluoranthene	48 T	130 T	230 TJ	120 T	230 TD	<1100
Benzoic acid	-	-	-	-	-	-
Benzyl alcohol	-	-	-	-	-	-
Benzyl butyl phthalate	-	-	-	-	-	-
Biphenyl (Diphenyl)	-	-	-	-	-	-

TABLE 2

SEMI-VOLATILE ORGANIC COMPOUNDS SOLID SAMPLE DATA SUMMARY
DEMONSTRATION TESTING AND FULL-SCALE OPERATION OF THE BIOGENESIS SEDIMENT DECONTAMINATION PROCESS
KEASBEY, NEW JERSEY
 (Page 3 of 108)

Field Sample Identification	BAY-1	RS-211205-1000	TS-211205-1715	WS1-211205-1800	TS-291205-1100	WS-291205-1110
Sediment Source	Raritan River	Raritan River	Raritan River	Raritan River	Raritan River	Raritan River
Location Identification	PPS	RS	TS	WS	TS	WS
Date Collected	11/23/05	12/21/05	12/21/05	12/21/05	12/29/05	12/29/05
Matrix	Solid	Solid	Solid	Solid	Solid	Solid
Analyte/Methods (Units)						
Semi-Volatile Organic Compounds/SW8270C (µg/kg) (continued)						
bis(2-chloroethoxy) Methane	-	-	-	-	-	-
bis(2-chloroethyl) Ether	-	-	-	-	-	-
bis(2-chloroisopropyl) Ether	-	-	-	-	-	-
bis(2-ethylhexyl) Phthalate	-	-	-	-	-	-
Caprolactam	-	-	-	-	-	-
Carbazole	-	-	-	-	-	-
Chrysene	170 T	370 T	520 J	290 T	510 TD	42 T
Cresols, m	-	<910	<450 UJ	<1100	<960 D	<1100
Cresols, Total	-	-	-	-	-	-
Di-n-butyl phthalate	-	-	-	-	-	-
Di-n-octylphthalate	-	-	-	-	-	-
Dibenz(a,h)anthracene	30 T	<15	86 TJ	68 T	<16 D	<17
Dibenzofuran	-	-	-	-	-	-
Diethyl Phthalate	-	-	-	-	-	-
Dimethyl phthalate	-	-	-	-	-	-
Fluoranthene	290 T	630 T	820 J	740 T	790 TD	73 T
Fluorene	18 T	88 T	77 TJ	150 T	76 TD	<1100
Hexachlorobenzene	-	<910	<450 UJ	<1100	<960 D	<1100
Hexachlorobutadiene	-	<910	<450 UJ	<1100	<960 D	<1100
Hexachlorocyclopentadiene	-	-	-	-	-	-
Hexachloroethane	-	<910	<450 UJ	<1100	<960 D	<1100
Indeno(1,2,3-c,d)Pyrene	110 T	260 T	380 TJ	260 T	310 TD	<1100
Isophorone	-	-	-	-	-	-
n-Nitroso-di-n-propylamine	-	-	-	-	-	-
n-Nitrosodimethylamine	-	-	-	-	-	-

TABLE 2
SEMI-VOLATILE ORGANIC COMPOUNDS SOLID SAMPLE DATA SUMMARY
DEMONSTRATION TESTING AND FULL-SCALE OPERATION OF THE BIOGENESIS SEDIMENT DECONTAMINATION PROCESS
KEASBEY, NEW JERSEY
(Page 4 of 108)

Field Sample Identification	BAY-1	RS-211205-1000	TS-211205-1715	WS1-211205-1800	TS-291205-1100	WS-291205-1110
Sediment Source	Raritan River	Raritan River	Raritan River	Raritan River	Raritan River	Raritan River
Location Identification	PPS	RS	TS	WS	TS	WS
Date Collected	11/23/05	12/21/05	12/21/05	12/21/05	12/29/05	12/29/05
Matrix	Solid	Solid	Solid	Solid	Solid	Solid
Analyte/Methods (Units)						
Semi-Volatile Organic Compounds/SW8270C (µg/kg) (continued)						
n-Nitrosodiphenylamine	-	-	-	-	-	-
Naphthalene	30 T	110 T	150 TJ	140 T	48 TD	<1100
Nitrobenzene	-	<910	<450 UJ	<1100	<960 D	<1100
Pentachlorophenol	-	<4400	<2200	<5100	<4700 D	<5100
Phenanthrene	150 T	-	-	-	-	-
Phenol	-	-	-	-	-	-
Pyrene	590 T	650 T	840 J	800 T	900 TD	92 T
Pyridine	-	-	-	-	-	-

µg/kg micrograms per kilogram.
Italic Italicized result indicates analyte reported to the method detection limit.
Bold Bolded result indicates positively identified compound.
- Not analyzed.
B Analyte detected in an associated blank.
D Sample dilution required for analysis; reported values reflect the dilution.
H Sample holding time was exceeded, but the associated data are considered valid as reported.
J Data are estimated due to associated quality control data.
R Associated quality control did not meet acceptance criteria.
T Analyte was positively identified but the reported concentration is estimated; reported concentration is less than the reporting limit, but greater than the method detection limit.
UJ Potential low bias, possible false negative.

TABLE 2

SEMI-VOLATILE ORGANIC COMPOUNDS SOLID SAMPLE DATA SUMMARY
DEMONSTRATION TESTING AND FULL-SCALE OPERATION OF THE BIOGENESIS SEDIMENT DECONTAMINATION PROCESS
KEASBEY, NEW JERSEY
 (Page 5 of 108)

Field Sample Identification	RS-030106-1600	TS-030106-1645	WS1-030106-1615	WS2-030106-1630	RS-040106-1300	TS-040106-1100
Sediment Source	Raritan River	Raritan River	Raritan River	Raritan River	Raritan River	Raritan River
Location Identification	RS	TS	WS1	WS2	RS	TS
Date Collected	1/3/06	1/3/06	1/3/06	1/3/06	1/4/06	1/4/06
Matrix	Solid	Solid	Solid	Solid	Solid	Solid
Analyte/Methods (Units)						
Semi-Volatile Organic Compounds/SW8270C (µg/kg)						
1,2,4-Trichlorobenzene	-	-	-	-	-	-
1,2-Dichlorobenzene	-	-	-	-	-	-
1,2-Diphenylhydrazine	-	-	-	-	-	-
1,3-Dichlorobenzene	-	-	-	-	-	-
1,4-Dichlorobenzene	<1800 DUJ	<920 D	<2500 D	<1900 D	<3000 D	<970 D
1,4-Dioxane (p-Dioxane)	-	-	-	-	-	-
2,3,4,6-Tetrachlorophenol	-	-	-	-	-	-
2,3,5,6-Tetrachlorophenol	-	-	-	-	-	-
2,4,5-Trichlorophenol	<1800 D	<920 D	<2500 D	<1900 D	<3000 D	<970 D
2,4,6-Trichlorophenol	<1800 D	<920 D	<2500 D	<1900 D	<3000 D	<970 D
2,4-Dichlorophenol	-	-	-	-	-	-
2,4-Dimethyl phenol	-	-	-	-	-	-
2,4-Dinitrophenol	-	-	-	-	-	-
2,4-Dinitrotoluene	<1800 D	<920 D	<2500 D	<1900 D	<3000 D	<970 D
2,6-Dichlorophenol	-	-	-	-	-	-
2,6-Dinitrotoluene	-	-	-	-	-	-
2-Aminonaphthalene	-	-	-	-	-	-
2-Chloronaphthalene	-	-	-	-	-	-
2-Chlorophenol	-	-	-	-	-	-
2-Methylnaphthalene	-	-	-	-	-	-
2-Methylphenol (o-Cresol)	<1800 D	<920 D	<2500 D	<1900 D	<3000 D	<970 D
2-Nitroaniline	-	-	-	-	-	-
2-Nitrophenol	-	-	-	-	-	-
3,3'-Dichlorobenzidine	-	-	-	-	-	-
3-Nitroaniline	-	-	-	-	-	-

TABLE 2

SEMI-VOLATILE ORGANIC COMPOUNDS SOLID SAMPLE DATA SUMMARY
DEMONSTRATION TESTING AND FULL-SCALE OPERATION OF THE BIOGENESIS SEDIMENT DECONTAMINATION PROCESS
KEASBEY, NEW JERSEY
 (Page 6 of 108)

Field Sample Identification	RS-030106-1600	TS-030106-1645	WS1-030106-1615	WS2-030106-1630	RS-040106-1300	TS-040106-1100
Sediment Source	Raritan River	Raritan River	Raritan River	Raritan River	Raritan River	Raritan River
Location Identification	RS	TS	WS1	WS2	RS	TS
Date Collected	1/3/06	1/3/06	1/3/06	1/3/06	1/4/06	1/4/06
Matrix	Solid	Solid	Solid	Solid	Solid	Solid
Analyte/Methods (Units)						
Semi-Volatile Organic Compounds/SW8270C (µg/kg) (continued)						
4,6-Dinitro-2-methylphenol	-	-	-	-	-	-
4-Bromophenyl phenyl ether	-	-	-	-	-	-
4-Chloro-3-methylphenol	-	-	-	-	-	-
4-Chloroaniline	-	-	-	-	-	-
4-Chlorophenyl phenyl ether	-	-	-	-	-	-
4-Methylphenol (p-Cresol)	-	-	-	-	-	-
4-Nitroaniline	-	-	-	-	-	-
4-Nitrophenol	-	-	-	-	-	-
Acenaphthene	43 TD	38 TD	<2500 D	<1900 D	<3000 D	<970 D
Acenaphthylene	62 TD	55 TD	<2500 D	<1900 D	63 TD	<970 D
Acetophenone	-	-	-	-	-	-
Aniline	-	-	-	-	-	-
Anthracene	120 TD	160 TD	100 TD	70 TD	120 TD	65 TD
Atrazine	-	-	-	-	-	-
Benzaldehyde	-	-	-	-	-	-
Benzydine	-	-	-	-	-	-
Benzo(a)anthracene	270 TD	380 TD	150 TD	85 TD	290 TD	170 TD
Benzo(a)pyrene	290 TD	370 TD	130 TD	69 TD	310 TD	190 TD
Benzo(b)fluoranthene	260 TD	340 TD	140 TD	69 TD	290 TD	180 TD
Benzo(g,h,i)perylene	220 TD	250 TD	<2500 D	<1900 D	230 TD	120 TD
Benzo(k)fluoranthene	120 TD	150 TD	<2500 D	<1900 D	110 TD	85 TD
Benzoic acid	-	-	-	-	-	-
Benzyl alcohol	-	-	-	-	-	-
Benzyl butyl phthalate	-	-	-	-	-	-
Biphenyl (Diphenyl)	-	-	-	-	-	-

TABLE 2
SEMI-VOLATILE ORGANIC COMPOUNDS SOLID SAMPLE DATA SUMMARY
DEMONSTRATION TESTING AND FULL-SCALE OPERATION OF THE BIOGENESIS SEDIMENT DECONTAMINATION PROCESS
KEASBEY, NEW JERSEY
 (Page 7 of 108)

Field Sample Identification	RS-030106-1600	TS-030106-1645	WS1-030106-1615	WS2-030106-1630	RS-040106-1300	TS-040106-1100
Sediment Source	Raritan River	Raritan River	Raritan River	Raritan River	Raritan River	Raritan River
Location Identification	RS	TS	WS1	WS2	RS	TS
Date Collected	1/3/06	1/3/06	1/3/06	1/3/06	1/4/06	1/4/06
Matrix	Solid	Solid	Solid	Solid	Solid	Solid
Analyte/Methods (Units)						
Semi-Volatile Organic Compounds/SW8270C (µg/kg) (continued)						
bis(2-chloroethoxy) Methane	-	-	-	-	-	-
bis(2-chloroethyl) Ether	-	-	-	-	-	-
bis(2-chloroisopropyl) Ether	-	-	-	-	-	-
bis(2-ethylhexyl) Phthalate	-	-	-	-	-	-
Caprolactam	-	-	-	-	-	-
Carbazole	-	-	-	-	-	-
Chrysene	280 TD	410 TD	130 TD	71 TD	290 TD	190 TD
Cresols, m	<1800 D	<920 D	<2500 D	<1900 D	<3000 D	<970 D
Cresols, Total	-	-	-	-	-	-
Di-n-butyl phthalate	-	-	-	-	-	-
Di-n-octylphthalate	-	-	-	-	-	-
Dibenz(a,h)anthracene	<30 D	61 TD	<40 D	<31 D	<49 D	<16 D
Dibenzofuran	-	-	-	-	-	-
Diethyl Phthalate	-	-	-	-	-	-
Dimethyl phthalate	-	-	-	-	-	-
Fluoranthene	480 TD	730 TD	280 TD	190 TD	470 TD	290 TD
Fluorene	46 TD	55 TD	<2500 D	47 TD	<3000 D	<970 D
Hexachlorobenzene	<1800 D	<920 D	<50 D	<1900 D	<61 D	<970 D
Hexachlorobutadiene	<1800 D	<920 D	<2500 D	<1900 D	<3000 D	<970 D
Hexachlorocyclopentadiene	-	-	-	-	-	-
Hexachloroethane	<1800 DUJ	<920 D	<2500 D	<1900 D	<3000 D	<970 D
Indeno(1,2,3-c,d)Pyrene	190 TD	240 TD	<2500 D	49 TD	230 TD	110 TD
Isophorone	-	-	-	-	-	-
n-Nitroso-di-n-propylamine	-	-	-	-	-	-
n-Nitrosodimethylamine	-	-	-	-	-	-

TABLE 2
SEMI-VOLATILE ORGANIC COMPOUNDS SOLID SAMPLE DATA SUMMARY
DEMONSTRATION TESTING AND FULL-SCALE OPERATION OF THE BIOGENESIS SEDIMENT DECONTAMINATION PROCESS
KEASBEY, NEW JERSEY
(Page 8 of 108)

Field Sample Identification	RS-030106-1600	TS-030106-1645	WS1-030106-1615	WS2-030106-1630	RS-040106-1300	TS-040106-1100
Sediment Source	Raritan River	Raritan River	Raritan River	Raritan River	Raritan River	Raritan River
Location Identification	RS	TS	WS1	WS2	RS	TS
Date Collected	1/3/06	1/3/06	1/3/06	1/3/06	1/4/06	1/4/06
Matrix	Solid	Solid	Solid	Solid	Solid	Solid
Analyte/Methods (Units)						
Semi-Volatile Organic Compounds/SW8270C (µg/kg) (continued)						
n-Nitrosodiphenylamine	-	-	-	-	-	-
Naphthalene	73 TD	60 TD	<2500 D	<1900 D	<3000 D	47 TD
Nitrobenzene	<1800 D	<920 D	<2500 D	<1900 D	<3000 D	<970 D
Pentachlorophenol	<8800 D	<4500 D	<12000 D	<9200 D	<15000 D	<4700 D
Phenanthrene	-	-	-	-	-	-
Phenol	-	-	-	-	-	-
Pyrene	460 TD	620 TD	300 TD	190 TD	440 TD	310 TD
Pyridine	-	-	-	-	-	-

µg/kg micrograms per kilogram.
Italic Italicized result indicates analyte reported to the method detection limit.
Bold Bolded result indicates positively identified compound.
- Not analyzed.
B Analyte detected in an associated blank.
D Sample dilution required for analysis; reported values reflect the dilution.
H Sample holding time was exceeded, but the associated data are considered valid as reported.
J Data are estimated due to associated quality control data.
R Associated quality control did not meet acceptance criteria.
T Analyte was positively identified but the reported concentration is estimated; reported concentration is less than the reporting limit, but greater than the method detection limit.
UJ Potential low bias, possible false negative.

TABLE 2

SEMI-VOLATILE ORGANIC COMPOUNDS SOLID SAMPLE DATA SUMMARY
DEMONSTRATION TESTING AND FULL-SCALE OPERATION OF THE BIOGENESIS SEDIMENT DECONTAMINATION PROCESS
KEASBEY, NEW JERSEY
 (Page 9 of 108)

Field Sample Identification	WS-040106-1400	RS-050106-1500	TS-050106-1505	WS-050106-1510	RS-060106-1531	TS-060106-1532
Sediment Source	Raritan River	Raritan River	Raritan River	Raritan River	Raritan River	Raritan River
Location Identification	WS	RS	TS	WS	RS	TS
Date Collected	1/4/06	1/5/06	1/5/06	1/5/06	1/6/06	1/6/06
Matrix	Solid	Solid	Solid	Solid	Solid	Solid
Analyte/Methods (Units)						
Semi-Volatile Organic Compounds/SW8270C (µg/kg)						
1,2,4-Trichlorobenzene	-	-	-	-	-	-
1,2-Dichlorobenzene	-	-	-	-	-	-
1,2-Diphenylhydrazine	-	-	-	-	-	-
1,3-Dichlorobenzene	-	-	-	-	-	-
1,4-Dichlorobenzene	<2100 DR	<2000 D	<990 D	<1800 D	<4000	<1000 D
1,4-Dioxane (p-Dioxane)	-	-	-	-	-	-
2,3,4,6-Tetrachlorophenol	-	-	-	-	-	-
2,3,5,6-Tetrachlorophenol	-	-	-	-	-	-
2,4,5-Trichlorophenol	<2100 DR	<2000 D	<990 D	<1800 D	<4000	<1000 D
2,4,6-Trichlorophenol	<2100 DR	<2000 D	<990 D	<1800 D	<4000	<1000 D
2,4-Dichlorophenol	-	-	-	-	-	-
2,4-Dimethyl phenol	-	-	-	-	-	-
2,4-Dinitrophenol	-	-	-	-	-	-
2,4-Dinitrotoluene	<2100 DR	<2000 D	<990 D	<1800 D	<4000	<1000 D
2,6-Dichlorophenol	-	-	-	-	-	-
2,6-Dinitrotoluene	-	-	-	-	-	-
2-Aminonaphthalene	-	-	-	-	-	-
2-Chloronaphthalene	-	-	-	-	-	-
2-Chlorophenol	-	-	-	-	-	-
2-Methylnaphthalene	-	-	-	-	-	-
2-Methylphenol (o-Cresol)	<2100 DR	<2000 D	<990 D	<1800 D	<4000	<1000 D
2-Nitroaniline	-	-	-	-	-	-
2-Nitrophenol	-	-	-	-	-	-
3,3'-Dichlorobenzidine	-	-	-	-	-	-
3-Nitroaniline	-	-	-	-	-	-

TABLE 2

SEMI-VOLATILE ORGANIC COMPOUNDS SOLID SAMPLE DATA SUMMARY
DEMONSTRATION TESTING AND FULL-SCALE OPERATION OF THE BIOGENESIS SEDIMENT DECONTAMINATION PROCESS
KEASBEY, NEW JERSEY
 (Page 10 of 108)

Field Sample Identification	WS-040106-1400	RS-050106-1500	TS-050106-1505	WS-050106-1510	RS-060106-1531	TS-060106-1532
Sediment Source	Raritan River	Raritan River	Raritan River	Raritan River	Raritan River	Raritan River
Location Identification	WS	RS	TS	WS	RS	TS
Date Collected	1/4/06	1/5/06	1/5/06	1/5/06	1/6/06	1/6/06
Matrix	Solid	Solid	Solid	Solid	Solid	Solid
Analyte/Methods (Units)						
Semi-Volatile Organic Compounds/SW8270C (µg/kg) (continued)						
4,6-Dinitro-2-methylphenol	-	-	-	-	-	-
4-Bromophenyl phenyl ether	-	-	-	-	-	-
4-Chloro-3-methylphenol	-	-	-	-	-	-
4-Chloroaniline	-	-	-	-	-	-
4-Chlorophenyl phenyl ether	-	-	-	-	-	-
4-Methylphenol (p-Cresol)	-	-	-	-	-	-
4-Nitroaniline	-	-	-	-	-	-
4-Nitrophenol	-	-	-	-	-	-
Acenaphthene	<2100 DR	92 TD	73 TD	<1800 D	<4000	34 TD
Acenaphthylene	<2100 DR	110 TD	68 TD	<1800 D	<4000	78 TD
Acetophenone	-	-	-	-	-	-
Aniline	-	-	-	-	-	-
Anthracene	<2100 DR	290 TD	200 TD	<1800 D	<4000	170 TD
Atrazine	-	-	-	-	-	-
Benzaldehyde	-	-	-	-	-	-
Benzydine	-	-	-	-	-	-
Benzo(a)anthracene	68 TDR	760 TD	340 TD	62 TD	<4000	400 TD
Benzo(a)pyrene	57 TDR	810 TD	370 TD	<31 D	180 T	470 TD
Benzo(b)fluoranthene	65 TDR	790 TD	360 TD	<1800 D	180 T	430 TD
Benzo(g,h,i)perylene	49 TDR	590 TD	250 TD	50 TD	<4000	310 TD
Benzo(k)fluoranthene	<2100 DR	370 TD	150 TD	<1800 D	<4000	180 TD
Benzoic acid	-	-	-	-	-	-
Benzyl alcohol	-	-	-	-	-	-
Benzyl butyl phthalate	-	-	-	-	-	-
Biphenyl (Diphenyl)	-	-	-	-	-	-

TABLE 2

SEMI-VOLATILE ORGANIC COMPOUNDS SOLID SAMPLE DATA SUMMARY
DEMONSTRATION TESTING AND FULL-SCALE OPERATION OF THE BIOGENESIS SEDIMENT DECONTAMINATION PROCESS
KEASBEY, NEW JERSEY
 (Page 11 of 108)

Field Sample Identification	WS-040106-1400	RS-050106-1500	TS-050106-1505	WS-050106-1510	RS-060106-1531	TS-060106-1532
Sediment Source	Raritan River	Raritan River	Raritan River	Raritan River	Raritan River	Raritan River
Location Identification	WS	RS	TS	WS	RS	TS
Date Collected	1/4/06	1/5/06	1/5/06	1/5/06	1/6/06	1/6/06
Matrix	Solid	Solid	Solid	Solid	Solid	Solid
Analyte/Methods (Units)						
Semi-Volatile Organic Compounds/SW8270C (µg/kg) (continued)						
bis(2-chloroethoxy) Methane	-	-	-	-	-	-
bis(2-chloroethyl) Ether	-	-	-	-	-	-
bis(2-chloroisopropyl) Ether	-	-	-	-	-	-
bis(2-ethylhexyl) Phthalate	-	-	-	-	-	-
Caprolactam	-	-	-	-	-	-
Carbazole	-	-	-	-	-	-
Chrysene	59 TDR	780 TD	390 TD	55 TD	<4000	420 TD
Cresols, m	<2100 DR	<2000 D	<990 D	<1800 D	<4000	<1000 D
Cresols, Total	-	-	-	-	-	-
Di-n-butyl phthalate	-	-	-	-	-	-
Di-n-octylphthalate	-	-	-	-	-	-
Dibenz(a,h)anthracene	<35 DR	170 TD	<16 D	<30 D	<67	81 TD
Dibenzofuran	-	-	-	-	-	-
Diethyl Phthalate	-	-	-	-	-	-
Dimethyl phthalate	-	-	-	-	-	-
Fluoranthene	120 TDR	1700 TD	710 TD	120 TD	270 T	640 TD
Fluorene	<2100 DR	150 TD	96 TD	<1800 D	<4000	53 TD
Hexachlorobenzene	<43 DR	<2000 D	<990 D	<1800 D	<82	<1000 D
Hexachlorobutadiene	<2100 DR	<2000 D	<990 D	<1800 D	<4000	<1000 D
Hexachlorocyclopentadiene	-	-	-	-	-	-
Hexachloroethane	<2100 DR	<2000 D	<990 D	<1800 D	<4000	<1000 D
Indeno(1,2,3-c,d)Pyrene	44 TDR	560 TD	250 TD	43 TD	<4000	290 TD
Isophorone	-	-	-	-	-	-
n-Nitroso-di-n-propylamine	-	-	-	-	-	-
n-Nitrosodimethylamine	-	-	-	-	-	-

TABLE 2

SEMI-VOLATILE ORGANIC COMPOUNDS SOLID SAMPLE DATA SUMMARY
DEMONSTRATION TESTING AND FULL-SCALE OPERATION OF THE BIOGENESIS SEDIMENT DECONTAMINATION PROCESS
KEASBEY, NEW JERSEY
 (Page 12 of 108)

Field Sample Identification	WS-040106-1400	RS-050106-1500	TS-050106-1505	WS-050106-1510	RS-060106-1531	TS-060106-1532
Sediment Source	Raritan River	Raritan River	Raritan River	Raritan River	Raritan River	Raritan River
Location Identification	WS	RS	TS	WS	RS	TS
Date Collected	1/4/06	1/5/06	1/5/06	1/5/06	1/6/06	1/6/06
Matrix	Solid	Solid	Solid	Solid	Solid	Solid
Analyte/Methods (Units)						
Semi-Volatile Organic Compounds/SW8270C (µg/kg) (continued)						
n-Nitrosodiphenylamine	-	-	-	-	-	-
Naphthalene	<2100 DR	150 TD	170 TD	<1800 D	<4000	68 TD
Nitrobenzene	<2100 DR	<2000 D	<990 D	<1800 D	<4000	<1000 D
Pentachlorophenol	<10000 DR	<9800 D	<4800 D	<8900 D	<20000	<5000 D
Phenanthrene	-	-	-	-	-	-
Phenol	-	-	-	-	-	-
Pyrene	130 TDR	1500 TD	680 TD	130 TD	320 T	690 TD
Pyridine	-	-	-	-	-	-

µg/kg micrograms per kilogram.

Italic Italicized result indicates analyte reported to the method detection limit.

Bold Bolded result indicates positively identified compound.

- Not analyzed.

B Analyte detected in an associated blank.

D Sample dilution required for analysis; reported values reflect the dilution.

H Sample holding time was exceeded, but the associated data are considered valid as reported.

J Data are estimated due to associated quality control data.

R Associated quality control did not meet acceptance criteria.

T Analyte was positively identified but the reported concentration is estimated; reported concentration is less than the reporting limit, but greater than the method detection limit.

UJ Potential low bias, possible false negative.

TABLE 2

SEMI-VOLATILE ORGANIC COMPOUNDS SOLID SAMPLE DATA SUMMARY
DEMONSTRATION TESTING AND FULL-SCALE OPERATION OF THE BIOGENESIS SEDIMENT DECONTAMINATION PROCESS
KEASBEY, NEW JERSEY
 (Page 13 of 108)

Field Sample Identification	WS-060106-1533	RS-090106-1500	TS-090106-1501	WS-090106-1502	RS-100106-1600	TS-100106-1601
Sediment Source	Raritan River	Raritan River	Raritan River	Raritan River	Raritan River	Raritan River
Location Identification	WS	RS	TS	WS	RS	TS
Date Collected	1/6/06	1/9/06	1/9/06	1/9/06	1/10/06	1/10/06
Matrix	Solid	Solid	Solid	Solid	Solid	Solid
Analyte/Methods (Units)						
Semi-Volatile Organic Compounds/SW8270C (µg/kg)						
1,2,4-Trichlorobenzene	-	-	-	-	-	-
1,2-Dichlorobenzene	-	-	-	-	-	-
1,2-Diphenylhydrazine	-	-	-	-	-	-
1,3-Dichlorobenzene	-	-	-	-	-	-
1,4-Dichlorobenzene	<1900 D	<2600 D	<1000 D	<1800 D	<3300 D	<1200 D
1,4-Dioxane (p-Dioxane)	-	-	-	-	-	-
2,3,4,6-Tetrachlorophenol	-	-	-	-	-	-
2,3,5,6-Tetrachlorophenol	-	-	-	-	-	-
2,4,5-Trichlorophenol	<1900 D	<2600 D	<1000 D	<1800 D	<3300 D	<1200 D
2,4,6-Trichlorophenol	<1900 D	<2600 D	<1000 D	<1800 D	<3300 D	<1200 D
2,4-Dichlorophenol	-	-	-	-	-	-
2,4-Dimethyl phenol	-	-	-	-	-	-
2,4-Dinitrophenol	-	-	-	-	-	-
2,4-Dinitrotoluene	<1900 D	<2600 D	<1000 D	<1800 D	<3300 D	<1200 D
2,6-Dichlorophenol	-	-	-	-	-	-
2,6-Dinitrotoluene	-	-	-	-	-	-
2-Aminonaphthalene	-	-	-	-	-	-
2-Chloronaphthalene	-	-	-	-	-	-
2-Chlorophenol	-	-	-	-	-	-
2-Methylnaphthalene	-	-	-	-	-	-
2-Methylphenol (o-Cresol)	<1900 D	<2600 D	<1000 D	<1800 D	<3300 D	120 TD
2-Nitroaniline	-	-	-	-	-	-
2-Nitrophenol	-	-	-	-	-	-
3,3'-Dichlorobenzidine	-	-	-	-	-	-
3-Nitroaniline	-	-	-	-	-	-

TABLE 2

SEMI-VOLATILE ORGANIC COMPOUNDS SOLID SAMPLE DATA SUMMARY
DEMONSTRATION TESTING AND FULL-SCALE OPERATION OF THE BIOGENESIS SEDIMENT DECONTAMINATION PROCESS
KEASBEY, NEW JERSEY
 (Page 14 of 108)

Field Sample Identification	WS-060106-1533	RS-090106-1500	TS-090106-1501	WS-090106-1502	RS-100106-1600	TS-100106-1601
Sediment Source	Raritan River	Raritan River	Raritan River	Raritan River	Raritan River	Raritan River
Location Identification	WS	RS	TS	WS	RS	TS
Date Collected	1/6/06	1/9/06	1/9/06	1/9/06	1/10/06	1/10/06
Matrix	Solid	Solid	Solid	Solid	Solid	Solid
Analyte/Methods (Units)						
Semi-Volatile Organic Compounds/SW8270C (µg/kg) (continued)						
4,6-Dinitro-2-methylphenol	-	-	-	-	-	-
4-Bromophenyl phenyl ether	-	-	-	-	-	-
4-Chloro-3-methylphenol	-	-	-	-	-	-
4-Chloroaniline	-	-	-	-	-	-
4-Chlorophenyl phenyl ether	-	-	-	-	-	-
4-Methylphenol (p-Cresol)	-	-	-	-	-	-
4-Nitroaniline	-	-	-	-	-	-
4-Nitrophenol	-	-	-	-	-	-
Acenaphthene	<1900 D	<2600 D	32 TD	<1800 D	<3300 D	340 TD
Acenaphthylene	<1900 D	77 TD	67 TD	<1800 D	100 TD	190 TD
Acetophenone	-	-	-	-	-	-
Aniline	-	-	-	-	-	-
Anthracene	<1900 D	160 TD	120 TD	51 TD	210 TD	670 TD
Atrazine	-	-	-	-	-	-
Benzaldehyde	-	-	-	-	-	-
Benzydine	-	-	-	-	-	-
Benzo(a)anthracene	<1900 D	380 TD	310 TD	86 TD	560 TD	1800 D
Benzo(a)pyrene	<32 D	420 TD	380 TD	<30 D	630 TD	1900 D
Benzo(b)fluoranthene	50 TD	410 TD	320 TD	65 TD	640 TD	1900 D
Benzo(g,h,i)perylene	<1900 D	310 TD	270 TD	70 TD	480 TD	1500 D
Benzo(k)fluoranthene	<1900 D	150 TD	150 TD	35 TD	240 TD	740 TD
Benzoic acid	-	-	-	-	-	-
Benzyl alcohol	-	-	-	-	-	-
Benzyl butyl phthalate	-	-	-	-	-	-
Biphenyl (Diphenyl)	-	-	-	-	-	-

TABLE 2

SEMI-VOLATILE ORGANIC COMPOUNDS SOLID SAMPLE DATA SUMMARY
DEMONSTRATION TESTING AND FULL-SCALE OPERATION OF THE BIOGENESIS SEDIMENT DECONTAMINATION PROCESS
KEASBEY, NEW JERSEY
 (Page 15 of 108)

Field Sample Identification	WS-060106-1533	RS-090106-1500	TS-090106-1501	WS-090106-1502	RS-100106-1600	TS-100106-1601
Sediment Source	Raritan River	Raritan River	Raritan River	Raritan River	Raritan River	Raritan River
Location Identification	WS	RS	TS	WS	RS	TS
Date Collected	1/6/06	1/9/06	1/9/06	1/9/06	1/10/06	1/10/06
Matrix	Solid	Solid	Solid	Solid	Solid	Solid
Analyte/Methods (Units)						
Semi-Volatile Organic Compounds/SW8270C (µg/kg) (continued)						
bis(2-chloroethoxy) Methane	-	-	-	-	-	-
bis(2-chloroethyl) Ether	-	-	-	-	-	-
bis(2-chloroisopropyl) Ether	-	-	-	-	-	-
bis(2-ethylhexyl) Phthalate	-	-	-	-	-	-
Caprolactam	-	-	-	-	-	-
Carbazole	-	-	-	-	-	-
Chrysene	<1900 D	370 TD	280 TD	66 TD	620 TD	1900 D
Cresols, m	<1900 D	<2600 D	<1000 D	<1800 D	<3300 D	320 TD
Cresols, Total	-	-	-	-	-	-
Di-n-butyl phthalate	-	-	-	-	-	-
Di-n-octylphthalate	-	-	-	-	-	-
Dibenz(a,h)anthracene	<31 D	<43 D	69 TD	<29 D	<55 D	330 TD
Dibenzofuran	-	-	-	-	-	-
Diethyl Phthalate	-	-	-	-	-	-
Dimethyl phthalate	-	-	-	-	-	-
Fluoranthene	100 TD	650 TD	520 TD	160 TD	760 TD	3600 D
Fluorene	<1900 D	<2600 D	<1000 D	<1800 D	<3300 D	320 TD
Hexachlorobenzene	<1900 D	<53 D	<1000 D	<1800 D	<68 D	<1200 D
Hexachlorobutadiene	<1900 D	<2600 D	<1000 D	<1800 D	<3300 D	<1200 D
Hexachlorocyclopentadiene	-	-	-	-	-	-
Hexachloroethane	<1900 D	<2600 D	<1000 D	<1800 D	<3300 D	<1200 D
Indeno(1,2,3-c,d)Pyrene	<1900 D	270 TD	220 TD	59 TD	450 TD	1400 D
Isophorone	-	-	-	-	-	-
n-Nitroso-di-n-propylamine	-	-	-	-	-	-
n-Nitrosodimethylamine	-	-	-	-	-	-

TABLE 2
SEMI-VOLATILE ORGANIC COMPOUNDS SOLID SAMPLE DATA SUMMARY
DEMONSTRATION TESTING AND FULL-SCALE OPERATION OF THE BIOGENESIS SEDIMENT DECONTAMINATION PROCESS
KEASBEY, NEW JERSEY
(Page 16 of 108)

Field Sample Identification	WS-060106-1533	RS-090106-1500	TS-090106-1501	WS-090106-1502	RS-100106-1600	TS-100106-1601
Sediment Source	Raritan River	Raritan River	Raritan River	Raritan River	Raritan River	Raritan River
Location Identification	WS	RS	TS	WS	RS	TS
Date Collected	1/6/06	1/9/06	1/9/06	1/9/06	1/10/06	1/10/06
Matrix	Solid	Solid	Solid	Solid	Solid	Solid
Analyte/Methods (Units)						
Semi-Volatile Organic Compounds/SW8270C (µg/kg) (continued)						
n-Nitrosodiphenylamine	-	-	-	-	-	-
Naphthalene	<1900 D	96 TD	88 TD	<1800 D	150 TD	320 TD
Nitrobenzene	<1900 D	<2600 D	<1000 D	<1800 D	<3300 D	<1200 D
Pentachlorophenol	<9000 D	<13000 D	<4900 D	<8600 D	<16000 D	<5900 D
Phenanthrene	-	-	-	-	-	-
Phenol	-	-	-	-	-	-
Pyrene	120 TD	710 TD	570 TD	180 TD	1000 TD	3200 D
Pyridine	-	-	-	-	-	-

µg/kg micrograms per kilogram.
Italic Italicized result indicates analyte reported to the method detection limit.
Bold Bolded result indicates positively identified compound.
- Not analyzed.
B Analyte detected in an associated blank.
D Sample dilution required for analysis; reported values reflect the dilution.
H Sample holding time was exceeded, but the associated data are considered valid as reported.
J Data are estimated due to associated quality control data.
R Associated quality control did not meet acceptance criteria.
T Analyte was positively identified but the reported concentration is estimated; reported concentration is less than the reporting limit, but greater than the method detection limit.
UJ Potential low bias, possible false negative.

TABLE 2

SEMI-VOLATILE ORGANIC COMPOUNDS SOLID SAMPLE DATA SUMMARY
DEMONSTRATION TESTING AND FULL-SCALE OPERATION OF THE BIOGENESIS SEDIMENT DECONTAMINATION PROCESS
KEASBEY, NEW JERSEY
 (Page 17 of 108)

Field Sample Identification	WS-100106-1602	RS-110106-1630	TS-110106-1631	RS-120106-1630	TS-120106-1601	WS-120106-1602
Sediment Source	Raritan River	Raritan River	Raritan River	Raritan River	Raritan River	Raritan River
Location Identification	WS	RS	TS	RS	TS	WS
Date Collected	1/10/06	1/11/06	1/11/06	1/12/06	1/12/06	1/12/06
Matrix	Solid	Solid	Solid	Solid	Solid	Solid
Analyte/Methods (Units)						
Semi-Volatile Organic Compounds/SW8270C (µg/kg)						
1,2,4-Trichlorobenzene	-	-	-	-	-	-
1,2-Dichlorobenzene	-	-	-	-	-	-
1,2-Diphenylhydrazine	-	-	-	-	-	-
1,3-Dichlorobenzene	-	-	-	-	-	-
1,4-Dichlorobenzene	<1600 D	<1900 D	<1400 D	<2400 D	<1100 D	<2100 D
1,4-Dioxane (p-Dioxane)	-	-	-	-	-	-
2,3,4,6-Tetrachlorophenol	-	-	-	-	-	-
2,3,5,6-Tetrachlorophenol	-	-	-	-	-	-
2,4,5-Trichlorophenol	<1600 D	<1900 D	<1400 D	<2400 D	<1100 D	<2100 D
2,4,6-Trichlorophenol	<1600 D	<1900 D	<1400 D	<2400 D	<1100 D	<2100 D
2,4-Dichlorophenol	-	-	-	-	-	-
2,4-Dimethyl phenol	-	-	-	-	-	-
2,4-Dinitrophenol	-	-	-	-	-	-
2,4-Dinitrotoluene	<1600 D	<1900 D	<1400 D	<2400 D	<1100 D	<2100 D
2,6-Dichlorophenol	-	-	-	-	-	-
2,6-Dinitrotoluene	-	-	-	-	-	-
2-Aminonaphthalene	-	-	-	-	-	-
2-Chloronaphthalene	-	-	-	-	-	-
2-Chlorophenol	-	-	-	-	-	-
2-Methylnaphthalene	-	-	-	-	-	-
2-Methylphenol (o-Cresol)	<1600 D	<1900 D	<1400 D	<2400 D	<1100 D	<2100 D
2-Nitroaniline	-	-	-	-	-	-
2-Nitrophenol	-	-	-	-	-	-
3,3'-Dichlorobenzidine	-	-	-	-	-	-
3-Nitroaniline	-	-	-	-	-	-

TABLE 2

SEMI-VOLATILE ORGANIC COMPOUNDS SOLID SAMPLE DATA SUMMARY
DEMONSTRATION TESTING AND FULL-SCALE OPERATION OF THE BIOGENESIS SEDIMENT DECONTAMINATION PROCESS
KEASBEY, NEW JERSEY
 (Page 18 of 108)

Field Sample Identification	WS-100106-1602	RS-110106-1630	TS-110106-1631	RS-120106-1630	TS-120106-1601	WS-120106-1602
Sediment Source	Raritan River	Raritan River	Raritan River	Raritan River	Raritan River	Raritan River
Location Identification	WS	RS	TS	RS	TS	WS
Date Collected	1/10/06	1/11/06	1/11/06	1/12/06	1/12/06	1/12/06
Matrix	Solid	Solid	Solid	Solid	Solid	Solid
Analyte/Methods (Units)						
Semi-Volatile Organic Compounds/SW8270C (µg/kg) (continued)						
4,6-Dinitro-2-methylphenol	-	-	-	-	-	-
4-Bromophenyl phenyl ether	-	-	-	-	-	-
4-Chloro-3-methylphenol	-	-	-	-	-	-
4-Chloroaniline	-	-	-	-	-	-
4-Chlorophenyl phenyl ether	-	-	-	-	-	-
4-Methylphenol (p-Cresol)	-	-	-	-	-	-
4-Nitroaniline	-	-	-	-	-	-
4-Nitrophenol	-	-	-	-	-	-
Acenaphthene	<1600 D	41 TD	380 TD	<2400 D	340 TD	<2100 D
Acenaphthylene	41 TD	81 TD	120 TD	80 TD	240 TD	56 TD
Acetophenone	-	-	-	-	-	-
Aniline	-	-	-	-	-	-
Anthracene	82 TD	160 TD	530 TD	130 TD	590 TD	94 TD
Atrazine	-	-	-	-	-	-
Benzaldehyde	-	-	-	-	-	-
Benzydine	-	-	-	-	-	-
Benzo(a)anthracene	140 TD	350 TD	1100 TD	290 TD	1800 D	150 TD
Benzo(a)pyrene	150 TD	400 TD	1100 TD	330 TD	2000 D	130 TD
Benzo(b)fluoranthene	150 TD	410 TD	1200 TD	320 TD	2100 D	180 TD
Benzo(g,h,i)perylene	120 TD	350 TD	810 TD	220 TD	1200 D	140 TD
Benzo(k)fluoranthene	66 TD	140 TD	510 TD	120 TD	830 TD	58 TD
Benzoic acid	-	-	-	-	-	-
Benzyl alcohol	-	-	-	-	-	-
Benzyl butyl phthalate	-	-	-	-	-	-
Biphenyl (Diphenyl)	-	-	-	-	-	-

TABLE 2

SEMI-VOLATILE ORGANIC COMPOUNDS SOLID SAMPLE DATA SUMMARY
DEMONSTRATION TESTING AND FULL-SCALE OPERATION OF THE BIOGENESIS SEDIMENT DECONTAMINATION PROCESS
KEASBEY, NEW JERSEY
 (Page 19 of 108)

Field Sample Identification	WS-100106-1602	RS-110106-1630	TS-110106-1631	RS-120106-1630	TS-120106-1601	WS-120106-1602
Sediment Source	Raritan River	Raritan River	Raritan River	Raritan River	Raritan River	Raritan River
Location Identification	WS	RS	TS	RS	TS	WS
Date Collected	1/10/06	1/11/06	1/11/06	1/12/06	1/12/06	1/12/06
Matrix	Solid	Solid	Solid	Solid	Solid	Solid
Analyte/Methods (Units)						
Semi-Volatile Organic Compounds/SW8270C (µg/kg) (continued)						
bis(2-chloroethoxy) Methane	-	-	-	-	-	-
bis(2-chloroethyl) Ether	-	-	-	-	-	-
bis(2-chloroisopropyl) Ether	-	-	-	-	-	-
bis(2-ethylhexyl) Phthalate	-	-	-	-	-	-
Caprolactam	-	-	-	-	-	-
Carbazole	-	-	-	-	-	-
Chrysene	140 TD	390 TD	1200 TD	310 TD	1900 D	160 TD
Cresols, m	<1600 D	<1900 D	<1400 D	<2400 D	<1100 D	<2100 D
Cresols, Total	-	-	-	-	-	-
Di-n-butyl phthalate	-	-	-	-	-	-
Di-n-octylphthalate	-	-	-	-	-	-
Dibenz(a,h)anthracene	<27 D	<31 D	200 TD	<39 D	290 TD	<34 D
Dibenzofuran	-	-	-	-	-	-
Diethyl Phthalate	-	-	-	-	-	-
Dimethyl phthalate	-	-	-	-	-	-
Fluoranthene	250 TD	600 TD	2500 D	510 TD	2800 D	320 TD
Fluorene	42 TD	63 TD	340 TD	<2400 D	290 TD	<2100 D
Hexachlorobenzene	<1600 D	<1900 D	<1400 D	<48 D	<1100 D	<42 D
Hexachlorobutadiene	<1600 D	<1900 D	<1400 D	<2400 D	<1100 D	<2100 D
Hexachlorocyclopentadiene	-	-	-	-	-	-
Hexachloroethane	<1600 D	<1900 D	<1400 D	<2400 D	<1100 D	<2100 D
Indeno(1,2,3-c,d)Pyrene	120 TD	320 TD	840 TD	200 TD	1200 D	130 TD
Isophorone	-	-	-	-	-	-
n-Nitroso-di-n-propylamine	-	-	-	-	-	-
n-Nitrosodimethylamine	-	-	-	-	-	-

TABLE 2

SEMI-VOLATILE ORGANIC COMPOUNDS SOLID SAMPLE DATA SUMMARY
DEMONSTRATION TESTING AND FULL-SCALE OPERATION OF THE BIOGENESIS SEDIMENT DECONTAMINATION PROCESS
KEASBEY, NEW JERSEY
 (Page 20 of 108)

Field Sample Identification	WS-100106-1602	RS-110106-1630	TS-110106-1631	RS-120106-1630	TS-120106-1601	WS-120106-1602
Sediment Source	Raritan River	Raritan River	Raritan River	Raritan River	Raritan River	Raritan River
Location Identification	WS	RS	TS	RS	TS	WS
Date Collected	1/10/06	1/11/06	1/11/06	1/12/06	1/12/06	1/12/06
Matrix	Solid	Solid	Solid	Solid	Solid	Solid
Analyte/Methods (Units)						
Semi-Volatile Organic Compounds/SW8270C (µg/kg) (continued)						
n-Nitrosodiphenylamine	-	-	-	-	-	-
Naphthalene	58 TD	110 TD	140 TD	<2400 D	340 TD	<2100 D
Nitrobenzene	<1600 D	<1900 D	<1400 D	<2400 D	<1100 D	<2100 D
Pentachlorophenol	<7900 D	<9000 D	<6700 D	<11000 D	<5400 D	<10000 D
Phenanthrene	-	-	-	-	-	-
Phenol	-	-	-	-	-	-
Pyrene	260 TD	710 TD	2200 D	520 TD	2800 D	320 TD
Pyridine	-	-	-	-	-	-

µg/kg micrograms per kilogram.

Italic Italicized result indicates analyte reported to the method detection limit.

Bold Bolded result indicates positively identified compound.

- Not analyzed.

B Analyte detected in an associated blank.

D Sample dilution required for analysis; reported values reflect the dilution.

H Sample holding time was exceeded, but the associated data are considered valid as reported.

J Data are estimated due to associated quality control data.

R Associated quality control did not meet acceptance criteria.

T Analyte was positively identified but the reported concentration is estimated; reported concentration is less than the reporting limit, but greater than the method detection limit.

UJ Potential low bias, possible false negative.

TABLE 2

SEMI-VOLATILE ORGANIC COMPOUNDS SOLID SAMPLE DATA SUMMARY
DEMONSTRATION TESTING AND FULL-SCALE OPERATION OF THE BIOGENESIS SEDIMENT DECONTAMINATION PROCESS
KEASBEY, NEW JERSEY
 (Page 21 of 108)

Field Sample Identification	RS-190106-1600	TS-190106-1601	WS-190106-1602	RS-240106-1530	TS-240106-1630	RS-270106-1400
Sediment Source	Lower Passaic River	Lower Passaic River	Lower Passaic River	Lower Passaic River	Lower Passaic River	Lower Passaic River
Location Identification	RS	TS	WS	RS	TS	RS
Date Collected	1/19/06	1/19/06	1/19/06	1/24/06	1/24/06	1/27/06
Matrix	Solid	Solid	Solid	Solid	Solid	Solid
Analyte/Methods (Units)						
Semi-Volatile Organic Compounds/SW8270C (µg/kg)						
1,2,4-Trichlorobenzene	-	-	-	-	-	-
1,2-Dichlorobenzene	-	-	-	-	-	-
1,2-Diphenylhydrazine	-	-	-	-	-	-
1,3-Dichlorobenzene	-	-	-	-	-	-
1,4-Dichlorobenzene	<18000 D	340 TD	<13000 D	89 TD	120 TD	<5200 D
1,4-Dioxane (p-Dioxane)	-	-	-	-	-	-
2,3,4,6-Tetrachlorophenol	-	-	-	-	-	-
2,3,5,6-Tetrachlorophenol	-	-	-	-	-	-
2,4,5-Trichlorophenol	<18000 D	<6200 D	<13000 D	<3900 D	<5200 D	<5200 D
2,4,6-Trichlorophenol	<18000 D	<6200 D	<13000 D	<3900 D	<5200 D	<5200 D
2,4-Dichlorophenol	-	-	-	-	-	-
2,4-Dimethyl phenol	-	-	-	-	-	-
2,4-Dinitrophenol	-	-	-	-	-	-
2,4-Dinitrotoluene	<190 D	<65 D	<130 D	<3900 D	<55 D	<55 D
2,6-Dichlorophenol	-	-	-	-	-	-
2,6-Dinitrotoluene	-	-	-	-	-	-
2-Aminonaphthalene	-	-	-	-	-	-
2-Chloronaphthalene	-	-	-	-	-	-
2-Chlorophenol	-	-	-	-	-	-
2-Methylnaphthalene	-	-	-	-	-	-
2-Methylphenol (o-Cresol)	<18000 D	<6200 D	<13000 D	<3900 D	<5200 D	<5200 D
2-Nitroaniline	-	-	-	-	-	-
2-Nitrophenol	-	-	-	-	-	-
3,3'-Dichlorobenzidine	-	-	-	-	-	-
3-Nitroaniline	-	-	-	-	-	-

TABLE 2

SEMI-VOLATILE ORGANIC COMPOUNDS SOLID SAMPLE DATA SUMMARY
DEMONSTRATION TESTING AND FULL-SCALE OPERATION OF THE BIOGENESIS SEDIMENT DECONTAMINATION PROCESS
KEASBEY, NEW JERSEY
 (Page 22 of 108)

Field Sample Identification	RS-190106-1600	TS-190106-1601	WS-190106-1602	RS-240106-1530	TS-240106-1630	RS-270106-1400
Sediment Source	Lower Passaic River	Lower Passaic River	Lower Passaic River	Lower Passaic River	Lower Passaic River	Lower Passaic River
Location Identification	RS	TS	WS	RS	TS	RS
Date Collected	1/19/06	1/19/06	1/19/06	1/24/06	1/24/06	1/27/06
Matrix	Solid	Solid	Solid	Solid	Solid	Solid
Analyte/Methods (Units)						
Semi-Volatile Organic Compounds/SW8270C (µg/kg) (continued)						
4,6-Dinitro-2-methylphenol	-	-	-	-	-	-
4-Bromophenyl phenyl ether	-	-	-	-	-	-
4-Chloro-3-methylphenol	-	-	-	-	-	-
4-Chloroaniline	-	-	-	-	-	-
4-Chlorophenyl phenyl ether	-	-	-	-	-	-
4-Methylphenol (p-Cresol)	-	-	-	-	-	-
4-Nitroaniline	-	-	-	-	-	-
4-Nitrophenol	-	-	-	-	-	-
Acenaphthene	480 TD	550 TD	<13000 D	140 TD	190 TD	230 TD
Acenaphthylene	780 TD	1300 TD	<13000 D	340 TD	390 TD	420 TD
Acetophenone	-	-	-	-	-	-
Aniline	-	-	-	-	-	-
Anthracene	1300 TD	1500 TD	<13000 D	410 TD	510 TD	490 TD
Atrazine	-	-	-	-	-	-
Benzaldehyde	-	-	-	-	-	-
Benzidine	-	-	-	-	-	-
Benzo(a)anthracene	3500 TD	3600 TD	480 TD	1300 TD	1700 TDJ	1600 TD
Benzo(a)pyrene	3600 TD	3800 TD	490 TD	1400 TD	1800 TDJ	1700 TD
Benzo(b)fluoranthene	4100 TD	4300 TD	660 TD	1800 TD	2200 TDJ	2000 TD
Benzo(g,h,i)perylene	2800 TD	2500 TD	410 TD	940 TD	1200 TD	1500 TD
Benzo(k)fluoranthene	1500 TD	1700 TD	<250 D	640 TD	730 TDJ	810 TD
Benzoic acid	-	-	-	-	-	-
Benzyl alcohol	-	-	-	-	-	-
Benzyl butyl phthalate	-	-	-	-	-	-
Biphenyl (Diphenyl)	-	-	-	-	-	-

TABLE 2

SEMI-VOLATILE ORGANIC COMPOUNDS SOLID SAMPLE DATA SUMMARY
DEMONSTRATION TESTING AND FULL-SCALE OPERATION OF THE BIOGENESIS SEDIMENT DECONTAMINATION PROCESS
KEASBEY, NEW JERSEY
 (Page 23 of 108)

Field Sample Identification	RS-190106-1600	TS-190106-1601	WS-190106-1602	RS-240106-1530	TS-240106-1630	RS-270106-1400
Sediment Source	Lower Passaic River	Lower Passaic River	Lower Passaic River	Lower Passaic River	Lower Passaic River	Lower Passaic River
Location Identification	RS	TS	WS	RS	TS	RS
Date Collected	1/19/06	1/19/06	1/19/06	1/24/06	1/24/06	1/27/06
Matrix	Solid	Solid	Solid	Solid	Solid	Solid
Analyte/Methods (Units)						
Semi-Volatile Organic Compounds/SW8270C (µg/kg) (continued)						
bis(2-chloroethoxy) Methane	-	-	-	-	-	-
bis(2-chloroethyl) Ether	-	-	-	-	-	-
bis(2-chloroisopropyl) Ether	-	-	-	-	-	-
bis(2-ethylhexyl) Phthalate	-	-	-	-	-	-
Caprolactam	-	-	-	-	-	-
Carbazole	-	-	-	-	-	-
Chrysene	4200 TD	4300 TD	<13000 D	1800 TD	2100 TDJ	2000 TD
Cresols, m	<18000 D	340 TD	<13000 D	<3900 D	<5200 D	<5200 D
Cresols, Total	-	-	-	-	-	-
Di-n-butyl phthalate	-	-	-	-	-	-
Di-n-octylphthalate	-	-	-	-	-	-
Dibenz(a,h)anthracene	<290 D	580 TD	<210 D	230 TD	<87 D	300 TD
Dibenzofuran	-	-	-	-	-	-
Diethyl Phthalate	-	-	-	-	-	-
Dimethyl phthalate	-	-	-	-	-	-
Fluoranthene	6800 TD	7700 D	1100 TD	2900 TD	3500 TDJ	3300 TD
Fluorene	<18000 D	690 TD	<13000 D	180 TD	220 TD	290 TD
Hexachlorobenzene	<360 D	<130 D	<260 D	<79 D	<110 D	<110 D
Hexachlorobutadiene	<18000 D	<6200 D	<13000 D	<3900 D	<5200 D	<5200 D
Hexachlorocyclopentadiene	-	-	-	-	-	-
Hexachloroethane	<18000 D	<6200 D	<13000 D	<3900 D	<5200 D	<5200 D
Indeno(1,2,3-c,d)Pyrene	2400 TD	2400 TD	<250 D	770 TD	920 TD	1400 TD
Isophorone	-	-	-	-	-	-
n-Nitroso-di-n-propylamine	-	-	-	-	-	-
n-Nitrosodimethylamine	-	-	-	-	-	-

TABLE 2

SEMI-VOLATILE ORGANIC COMPOUNDS SOLID SAMPLE DATA SUMMARY
DEMONSTRATION TESTING AND FULL-SCALE OPERATION OF THE BIOGENESIS SEDIMENT DECONTAMINATION PROCESS
KEASBEY, NEW JERSEY
 (Page 24 of 108)

Field Sample Identification	RS-190106-1600	TS-190106-1601	WS-190106-1602	RS-240106-1530	TS-240106-1630	RS-270106-1400
Sediment Source	Lower Passaic River	Lower Passaic River	Lower Passaic River	Lower Passaic River	Lower Passaic River	Lower Passaic River
Location Identification	RS	TS	WS	RS	TS	RS
Date Collected	1/19/06	1/19/06	1/19/06	1/24/06	1/24/06	1/27/06
Matrix	Solid	Solid	Solid	Solid	Solid	Solid
Analyte/Methods (Units)						
Semi-Volatile Organic Compounds/SW8270C (µg/kg) (continued)						
n-Nitrosodiphenylamine	-	-	-	-	-	-
Naphthalene	<18000 D	540 TD	<13000 D	<3900 D	<5200 D	<5200 D
Nitrobenzene	<18000 D	<6200 D	<13000 D	<3900 D	<5200 D	<5200 D
Pentachlorophenol	<24000 D	<8600 D	<17000 D	<19000 D	<7300 D	<7200 D
Phenanthrene	-	-	-	-	-	-
Phenol	-	-	-	-	-	-
Pyrene	7200 TD	6500 D	1200 TD	2300 TD	3000 TDJ	3200 TD
Pyridine	-	-	-	-	-	-

µg/kg micrograms per kilogram.

Italic Italicized result indicates analyte reported to the method detection limit.

Bold Bolded result indicates positively identified compound.

- Not analyzed.

B Analyte detected in an associated blank.

D Sample dilution required for analysis; reported values reflect the dilution.

H Sample holding time was exceeded, but the associated data are considered valid as reported.

J Data are estimated due to associated quality control data.

R Associated quality control did not meet acceptance criteria.

T Analyte was positively identified but the reported concentration is estimated; reported concentration is less than the reporting limit, but greater than the method detection limit.

UJ Potential low bias, possible false negative.

TABLE 2

SEMI-VOLATILE ORGANIC COMPOUNDS SOLID SAMPLE DATA SUMMARY
DEMONSTRATION TESTING AND FULL-SCALE OPERATION OF THE BIOGENESIS SEDIMENT DECONTAMINATION PROCESS
KEASBEY, NEW JERSEY
 (Page 25 of 108)

Field Sample Identification	TS-270106-1401	TS-270106-1530	WS-270106-1402	WS-270106-1531	RS-300106-1700	WS2-300106-1702
Sediment Source	Lower Passaic River	Lower Passaic River	Lower Passaic River	Lower Passaic River	Raritan River	Raritan River
Location Identification	TS	TS	WS	WS	RS	WS2
Date Collected	1/27/06	1/27/06	1/27/06	1/27/06	1/30/06	1/30/06
Matrix	Solid	Solid	Solid	Solid	Solid	Solid
Analyte/Methods (Units)						
Semi-Volatile Organic Compounds/SW8270C (µg/kg)						
1,2,4-Trichlorobenzene	-	-	-	-	-	-
1,2-Dichlorobenzene	-	-	-	-	-	-
1,2-Diphenylhydrazine	-	-	-	-	-	-
1,3-Dichlorobenzene	-	-	-	-	-	-
1,4-Dichlorobenzene	<2500 D	<2700 D	<5900 D	<6300 D	80 T	160 TD
1,4-Dioxane (p-Dioxane)	-	-	-	-	-	-
2,3,4,6-Tetrachlorophenol	-	-	-	-	-	-
2,3,5,6-Tetrachlorophenol	-	-	-	-	-	-
2,4,5-Trichlorophenol	<2500 D	<2700 D	<5900 D	<6300 D	<1800	<1600 D
2,4,6-Trichlorophenol	<2500 D	<2700 D	<5900 D	<6300 D	<1800	<1600 D
2,4-Dichlorophenol	-	-	-	-	-	-
2,4-Dimethyl phenol	-	-	-	-	-	-
2,4-Dinitrophenol	-	-	-	-	-	-
2,4-Dinitrotoluene	<2500 D	<2700 D	<63 D	<67 D	<1800	<1600 D
2,6-Dichlorophenol	-	-	-	-	-	-
2,6-Dinitrotoluene	-	-	-	-	-	-
2-Aminonaphthalene	-	-	-	-	-	-
2-Chloronaphthalene	-	-	-	-	-	-
2-Chlorophenol	-	-	-	-	-	-
2-Methylnaphthalene	-	-	-	-	-	-
2-Methylphenol (o-Cresol)	<2500 D	<2700 D	<5900 D	<6300 D	<1800	<1600 D
2-Nitroaniline	-	-	-	-	-	-
2-Nitrophenol	-	-	-	-	-	-
3,3'-Dichlorobenzidine	-	-	-	-	-	-
3-Nitroaniline	-	-	-	-	-	-

TABLE 2

SEMI-VOLATILE ORGANIC COMPOUNDS SOLID SAMPLE DATA SUMMARY
DEMONSTRATION TESTING AND FULL-SCALE OPERATION OF THE BIOGENESIS SEDIMENT DECONTAMINATION PROCESS
KEASBEY, NEW JERSEY
 (Page 26 of 108)

Field Sample Identification	TS-270106-1401	TS-270106-1530	WS-270106-1402	WS-270106-1531	RS-300106-1700	WS2-300106-1702
Sediment Source	Lower Passaic River	Lower Passaic River	Lower Passaic River	Lower Passaic River	Raritan River	Raritan River
Location Identification	TS	TS	WS	WS	RS	WS2
Date Collected	1/27/06	1/27/06	1/27/06	1/27/06	1/30/06	1/30/06
Matrix	Solid	Solid	Solid	Solid	Solid	Solid
Analyte/Methods (Units)						
Semi-Volatile Organic Compounds/SW8270C (µg/kg) (continued)						
4,6-Dinitro-2-methylphenol	-	-	-	-	-	-
4-Bromophenyl phenyl ether	-	-	-	-	-	-
4-Chloro-3-methylphenol	-	-	-	-	-	-
4-Chloroaniline	-	-	-	-	-	-
4-Chlorophenyl phenyl ether	-	-	-	-	-	-
4-Methylphenol (p-Cresol)	-	-	-	-	-	-
4-Nitroaniline	-	-	-	-	-	-
4-Nitrophenol	-	-	-	-	-	-
Acenaphthene	520 TD	230 TD	210 TD	<6300 D	110 T	180 TD
Acenaphthylene	670 TD	600 TD	240 TD	170 TD	220 T	310 TD
Acetophenone	-	-	-	-	-	-
Aniline	-	-	-	-	-	-
Anthracene	1400 TD	640 TD	330 TD	260 TD	300 T	460 TD
Atrazine	-	-	-	-	-	-
Benzaldehyde	-	-	-	-	-	-
Benzydine	-	-	-	-	-	-
Benzo(a)anthracene	3100 D	2200 TD	770 TD	570 TD	820 T	1300 TD
Benzo(a)pyrene	2900 D	2300 TD	710 TD	510 TD	880 T	1400 TD
Benzo(b)fluoranthene	3100 D	2600 TD	1000 TD	740 TD	1000 T	1800 D
Benzo(g,h,i)perylene	1700 TDJ	910 TDJ	450 TD	300 TD	370 T	510 TD
Benzo(k)fluoranthene	1200 TD	1000 TD	410 TD	270 TD	380 T	800 TD
Benzoic acid	-	-	-	-	-	-
Benzyl alcohol	-	-	-	-	-	-
Benzyl butyl phthalate	-	-	-	-	-	-
Biphenyl (Diphenyl)	-	-	-	-	-	-

TABLE 2

SEMI-VOLATILE ORGANIC COMPOUNDS SOLID SAMPLE DATA SUMMARY
DEMONSTRATION TESTING AND FULL-SCALE OPERATION OF THE BIOGENESIS SEDIMENT DECONTAMINATION PROCESS
KEASBEY, NEW JERSEY
 (Page 27 of 108)

Field Sample Identification	TS-270106-1401	TS-270106-1530	WS-270106-1402	WS-270106-1531	RS-300106-1700	WS2-300106-1702
Sediment Source	Lower Passaic River	Lower Passaic River	Lower Passaic River	Lower Passaic River	Raritan River	Raritan River
Location Identification	TS	TS	WS	WS	RS	WS2
Date Collected	1/27/06	1/27/06	1/27/06	1/27/06	1/30/06	1/30/06
Matrix	Solid	Solid	Solid	Solid	Solid	Solid
Analyte/Methods (Units)						
Semi-Volatile Organic Compounds/SW8270C (µg/kg) (continued)						
bis(2-chloroethoxy) Methane	-	-	-	-	-	-
bis(2-chloroethyl) Ether	-	-	-	-	-	-
bis(2-chloroisopropyl) Ether	-	-	-	-	-	-
bis(2-ethylhexyl) Phthalate	-	-	-	-	-	-
Caprolactam	-	-	-	-	-	-
Carbazole	-	-	-	-	-	-
Chrysene	3300 D	2600 TD	1100 TD	750 TD	970 T	1700 D
Cresols, m	<2500 D	<2700 D	<5900 D	<6300 D	<1800	<1600 D
Cresols, Total	-	-	-	-	-	-
Di-n-butyl phthalate	-	-	-	-	-	-
Di-n-octylphthalate	-	-	-	-	-	-
Dibenz(a,h)anthracene	440 TD	240 TD	<98 D	<100 D	92 T	120 TD
Dibenzofuran	-	-	-	-	-	-
Diethyl Phthalate	-	-	-	-	-	-
Dimethyl phthalate	-	-	-	-	-	-
Fluoranthene	6600 D	4000 D	2100 TD	1400 TD	1600 T	3200 D
Fluorene	690 TD	250 TD	200 TD	<6300 D	150 T	190 TD
Hexachlorobenzene	<51 D	<55 D	<120 D	<130 D	<1800	<1600 D
Hexachlorobutadiene	<2500 D	<2700 D	<5900 D	<6300 D	<1800	<1600 D
Hexachlorocyclopentadiene	-	-	-	-	-	-
Hexachloroethane	<2500 D	<2700 D	<5900 D	<6300 D	<1800	<1600 D
Indeno(1,2,3-c,d)Pyrene	1900 TD	1100 TD	450 TD	260 TD	440 T	610 TD
Isophorone	-	-	-	-	-	-
n-Nitroso-di-n-propylamine	-	-	-	-	-	-
n-Nitrosodimethylamine	-	-	-	-	-	-

TABLE 2
SEMI-VOLATILE ORGANIC COMPOUNDS SOLID SAMPLE DATA SUMMARY
DEMONSTRATION TESTING AND FULL-SCALE OPERATION OF THE BIOGENESIS SEDIMENT DECONTAMINATION PROCESS
KEASBEY, NEW JERSEY
 (Page 28 of 108)

Field Sample Identification	TS-270106-1401	TS-270106-1530	WS-270106-1402	WS-270106-1531	RS-300106-1700	WS2-300106-1702
Sediment Source	Lower Passaic River	Lower Passaic River	Lower Passaic River	Lower Passaic River	Raritan River	Raritan River
Location Identification	TS	TS	WS	WS	RS	WS2
Date Collected	1/27/06	1/27/06	1/27/06	1/27/06	1/30/06	1/30/06
Matrix	Solid	Solid	Solid	Solid	Solid	Solid
Analyte/Methods (Units)						
Semi-Volatile Organic Compounds/SW8270C (µg/kg) (continued)						
n-Nitrosodiphenylamine	-	-	-	-	-	-
Naphthalene	320 TD	200 TD	<5900 D	<6300 D	160 T	240 TD
Nitrobenzene	<2500 D	<2700 D	<5900 D	<6300 D	<1800	<1600 D
Pentachlorophenol	<12000 D	<13000 D	<8200 D	<8800 D	<8600	<7700 D
Phenanthrene	-	-	-	-	-	-
Phenol	-	-	-	-	-	-
Pyrene	5700 D	3700 D	2000 TD	1300 TD	1500 T	2600 D
Pyridine	-	-	-	-	-	-

- µg/kg micrograms per kilogram.
- Italic* Italicized result indicates analyte reported to the method detection limit.
- Bold** Bolded result indicates positively identified compound.
- Not analyzed.
- B Analyte detected in an associated blank.
- D Sample dilution required for analysis; reported values reflect the dilution.
- H Sample holding time was exceeded, but the associated data are considered valid as reported.
- J Data are estimated due to associated quality control data.
- R Associated quality control did not meet acceptance criteria.
- T Analyte was positively identified but the reported concentration is estimated; reported concentration is less than the reporting limit, but greater than the method detection limit.
- UJ Potential low bias, possible false negative.

TABLE 2

SEMI-VOLATILE ORGANIC COMPOUNDS SOLID SAMPLE DATA SUMMARY
DEMONSTRATION TESTING AND FULL-SCALE OPERATION OF THE BIOGENESIS SEDIMENT DECONTAMINATION PROCESS
KEASBEY, NEW JERSEY
 (Page 29 of 108)

Field Sample Identification	RS-310106-1700	TS-310106-1701	WS-310106-1702	RS-010206-1600	TS-010206-1601	WS-010206-1602
Sediment Source	Raritan River	Raritan River	Raritan River	Raritan River	Raritan River	Raritan River
Location Identification	RS	TS	WS	RS	TS	WS
Date Collected	1/31/06	1/31/06	1/31/06	2/1/06	2/1/06	2/1/06
Matrix	Solid	Solid	Solid	Solid	Solid	Solid
Analyte/Methods (Units)						
Semi-Volatile Organic Compounds/SW8270C (µg/kg)						
1,2,4-Trichlorobenzene	-	-	-	-	-	-
1,2-Dichlorobenzene	-	-	-	-	-	-
1,2-Diphenylhydrazine	-	-	-	-	-	-
1,3-Dichlorobenzene	-	-	-	-	-	-
1,4-Dichlorobenzene	<1900	21 T	<1100	<1600	32 T	24 T
1,4-Dioxane (p-Dioxane)	-	-	-	-	-	-
2,3,4,6-Tetrachlorophenol	-	-	-	-	-	-
2,3,5,6-Tetrachlorophenol	-	-	-	-	-	-
2,4,5-Trichlorophenol	<1900	<540	<1100	<1600	<510	<930
2,4,6-Trichlorophenol	<1900	<540	<1100	<1600	<510	<930
2,4-Dichlorophenol	-	-	-	-	-	-
2,4-Dimethyl phenol	-	-	-	-	-	-
2,4-Dinitrophenol	-	-	-	-	-	-
2,4-Dinitrotoluene	<1900	<540	<1100	<1600	<510	<930
2,6-Dichlorophenol	-	-	-	-	-	-
2,6-Dinitrotoluene	-	-	-	-	-	-
2-Aminonaphthalene	-	-	-	-	-	-
2-Chloronaphthalene	-	-	-	-	-	-
2-Chlorophenol	-	-	-	-	-	-
2-Methylnaphthalene	-	-	-	-	-	-
2-Methylphenol (o-Cresol)	<1900	<540	<1100	<1600	<510	<930
2-Nitroaniline	-	-	-	-	-	-
2-Nitrophenol	-	-	-	-	-	-
3,3'-Dichlorobenzidine	-	-	-	-	-	-
3-Nitroaniline	-	-	-	-	-	-

TABLE 2

SEMI-VOLATILE ORGANIC COMPOUNDS SOLID SAMPLE DATA SUMMARY
DEMONSTRATION TESTING AND FULL-SCALE OPERATION OF THE BIOGENESIS SEDIMENT DECONTAMINATION PROCESS
KEASBEY, NEW JERSEY
 (Page 30 of 108)

Field Sample Identification	RS-310106-1700	TS-310106-1701	WS-310106-1702	RS-010206-1600	TS-010206-1601	WS-010206-1602
Sediment Source	Raritan River	Raritan River	Raritan River	Raritan River	Raritan River	Raritan River
Location Identification	RS	TS	WS	RS	TS	WS
Date Collected	1/31/06	1/31/06	1/31/06	2/1/06	2/1/06	2/1/06
Matrix	Solid	Solid	Solid	Solid	Solid	Solid
Analyte/Methods (Units)						
Semi-Volatile Organic Compounds/SW8270C (µg/kg) (continued)						
4,6-Dinitro-2-methylphenol	-	-	-	-	-	-
4-Bromophenyl phenyl ether	-	-	-	-	-	-
4-Chloro-3-methylphenol	-	-	-	-	-	-
4-Chloroaniline	-	-	-	-	-	-
4-Chlorophenyl phenyl ether	-	-	-	-	-	-
4-Methylphenol (p-Cresol)	-	-	-	-	-	-
4-Nitroaniline	-	-	-	-	-	-
4-Nitrophenol	-	-	-	-	-	-
Acenaphthene	<1900	62 T	<1100	56 T	110 T	35 T
Acenaphthylene	88 T	92 T	54 T	130 T	200 T	91 T
Acetophenone	-	-	-	-	-	-
Aniline	-	-	-	-	-	-
Anthracene	130 T	210 T	100 T	210 T	370 T	97 T
Atrazine	-	-	-	-	-	-
Benzaldehyde	-	-	-	-	-	-
Benzydine	-	-	-	-	-	-
Benzo(a)anthracene	290 T	520 T	160 T	460 T	880	240 T
Benzo(a)pyrene	330 T	520 T	140 T	500 T	900	250 T
Benzo(b)fluoranthene	350 T	560	190 T	470 T	860	270 T
Benzo(g,h,i)perylene	140 T	170 T	73 TJ	410 T	610	230 T
Benzo(k)fluoranthene	140 T	210 T	88 T	200 T	340 T	100 T
Benzoic acid	-	-	-	-	-	-
Benzyl alcohol	-	-	-	-	-	-
Benzyl butyl phthalate	-	-	-	-	-	-
Biphenyl (Diphenyl)	-	-	-	-	-	-

TABLE 2

SEMI-VOLATILE ORGANIC COMPOUNDS SOLID SAMPLE DATA SUMMARY
DEMONSTRATION TESTING AND FULL-SCALE OPERATION OF THE BIOGENESIS SEDIMENT DECONTAMINATION PROCESS
KEASBEY, NEW JERSEY
 (Page 31 of 108)

Field Sample Identification	RS-310106-1700	TS-310106-1701	WS-310106-1702	RS-010206-1600	TS-010206-1601	WS-010206-1602
Sediment Source	Raritan River	Raritan River	Raritan River	Raritan River	Raritan River	Raritan River
Location Identification	RS	TS	WS	RS	TS	WS
Date Collected	1/31/06	1/31/06	1/31/06	2/1/06	2/1/06	2/1/06
Matrix	Solid	Solid	Solid	Solid	Solid	Solid
Analyte/Methods (Units)						
Semi-Volatile Organic Compounds/SW8270C (µg/kg) (continued)						
bis(2-chloroethoxy) Methane	-	-	-	-	-	-
bis(2-chloroethyl) Ether	-	-	-	-	-	-
bis(2-chloroisopropyl) Ether	-	-	-	-	-	-
bis(2-ethylhexyl) Phthalate	-	-	-	-	-	-
Caprolactam	-	-	-	-	-	-
Carbazole	-	-	-	-	-	-
Chrysene	300 T	540	170 T	490 T	920	320 T
Cresols, m	<1900	<540	<1100	<1600	<510	<930
Cresols, Total	-	-	-	-	-	-
Di-n-butyl phthalate	-	-	-	-	-	-
Di-n-octylphthalate	-	-	-	-	-	-
Dibenz(a,h)anthracene	<32	48 T	<18	92 T	120 T	50 T
Dibenzofuran	-	-	-	-	-	-
Diethyl Phthalate	-	-	-	-	-	-
Dimethyl phthalate	-	-	-	-	-	-
Fluoranthene	480 T	940	360 T	650 T	1600	460 T
Fluorene	<1900	75 T	42 T	83 T	130 T	46 T
Hexachlorobenzene	<1900	<540	<1100	<1600	<510	<930
Hexachlorobutadiene	<1900	<540	<1100	<1600	<510	<930
Hexachlorocyclopentadiene	-	-	-	-	-	-
Hexachloroethane	<1900	<540	<1100 UJ	<1600	<510	<930
Indeno(1,2,3-c,d)Pyrene	130 T	190 T	70 TJ	370 T	610	180 T
Isophorone	-	-	-	-	-	-
n-Nitroso-di-n-propylamine	-	-	-	-	-	-
n-Nitrosodimethylamine	-	-	-	-	-	-

TABLE 2
SEMI-VOLATILE ORGANIC COMPOUNDS SOLID SAMPLE DATA SUMMARY
DEMONSTRATION TESTING AND FULL-SCALE OPERATION OF THE BIOGENESIS SEDIMENT DECONTAMINATION PROCESS
KEASBEY, NEW JERSEY
(Page 32 of 108)

Field Sample Identification	RS-310106-1700	TS-310106-1701	WS-310106-1702	RS-010206-1600	TS-010206-1601	WS-010206-1602
Sediment Source	Raritan River	Raritan River	Raritan River	Raritan River	Raritan River	Raritan River
Location Identification	RS	TS	WS	RS	TS	WS
Date Collected	1/31/06	1/31/06	1/31/06	2/1/06	2/1/06	2/1/06
Matrix	Solid	Solid	Solid	Solid	Solid	Solid
Analyte/Methods (Units)						
Semi-Volatile Organic Compounds/SW8270C (µg/kg) (continued)						
n-Nitrosodiphenylamine	-	-	-	-	-	-
Naphthalene	94 T	140 T	70 T	180 T	330 T	<930
Nitrobenzene	<1900	<540	<1100	<1600	<510	<930
Pentachlorophenol	<9300	<2600	<5300	<7600	<2500	<4500
Phenanthrene	-	-	-	-	-	-
Phenol	-	-	-	-	-	-
Pyrene	460 T	870	320 T	760 T	1300	420 T
Pyridine	-	-	-	-	-	-

- µg/kg micrograms per kilogram.
- Italic* Italicized result indicates analyte reported to the method detection limit.
- Bold** Bolded result indicates positively identified compound.
- Not analyzed.
- B Analyte detected in an associated blank.
- D Sample dilution required for analysis; reported values reflect the dilution.
- H Sample holding time was exceeded, but the associated data are considered valid as reported.
- J Data are estimated due to associated quality control data.
- R Associated quality control did not meet acceptance criteria.
- T Analyte was positively identified but the reported concentration is estimated; reported concentration is less than the reporting limit, but greater than the method detection limit.
- UJ Potential low bias, possible false negative.

TABLE 2

SEMI-VOLATILE ORGANIC COMPOUNDS SOLID SAMPLE DATA SUMMARY
DEMONSTRATION TESTING AND FULL-SCALE OPERATION OF THE BIOGENESIS SEDIMENT DECONTAMINATION PROCESS
KEASBEY, NEW JERSEY
 (Page 33 of 108)

Field Sample Identification	RS-020206-1800	TS-020206-1801	WS-020206-1802	RS-030206-1200	TS-030206-1201	WS-030206-1202
Sediment Source	Raritan River	Raritan River	Raritan River	Raritan River	Raritan River	Raritan River
Location Identification	RS	TS	WS	RS	TS	WS
Date Collected	2/2/06	2/2/06	2/2/06	2/3/06	2/3/06	2/3/06
Matrix	Solid	Solid	Solid	Solid	Solid	Solid
Analyte/Methods (Units)						
Semi-Volatile Organic Compounds/SW8270C (µg/kg)						
1,2,4-Trichlorobenzene	-	-	-	-	-	-
1,2-Dichlorobenzene	-	-	-	-	-	-
1,2-Diphenylhydrazine	-	-	-	-	-	-
1,3-Dichlorobenzene	-	-	-	-	-	-
1,4-Dichlorobenzene	<2100	31 T	<1000	<920	28 T	<1200 UJ
1,4-Dioxane (p-Dioxane)	-	-	-	-	-	-
2,3,4,6-Tetrachlorophenol	-	-	-	-	-	-
2,3,5,6-Tetrachlorophenol	-	-	-	-	-	-
2,4,5-Trichlorophenol	<2100	<530	<1000	<920	<530	<1200
2,4,6-Trichlorophenol	<2100	<530	<1000	<920	<530	<1200
2,4-Dichlorophenol	-	-	-	-	-	-
2,4-Dimethyl phenol	-	-	-	-	-	-
2,4-Dinitrophenol	-	-	-	-	-	-
2,4-Dinitrotoluene	<2100	<530	<1000	<920	<530	<1200
2,6-Dichlorophenol	-	-	-	-	-	-
2,6-Dinitrotoluene	-	-	-	-	-	-
2-Aminonaphthalene	-	-	-	-	-	-
2-Chloronaphthalene	-	-	-	-	-	-
2-Chlorophenol	-	-	-	-	-	-
2-Methylnaphthalene	-	-	-	-	-	-
2-Methylphenol (o-Cresol)	<2100	<530	<1000	<920	<530	<1200
2-Nitroaniline	-	-	-	-	-	-
2-Nitrophenol	-	-	-	-	-	-
3,3'-Dichlorobenzidine	-	-	-	-	-	-
3-Nitroaniline	-	-	-	-	-	-

TABLE 2

SEMI-VOLATILE ORGANIC COMPOUNDS SOLID SAMPLE DATA SUMMARY
DEMONSTRATION TESTING AND FULL-SCALE OPERATION OF THE BIOGENESIS SEDIMENT DECONTAMINATION PROCESS
KEASBEY, NEW JERSEY
 (Page 34 of 108)

Field Sample Identification	RS-020206-1800	TS-020206-1801	WS-020206-1802	RS-030206-1200	TS-030206-1201	WS-030206-1202
Sediment Source	Raritan River	Raritan River	Raritan River	Raritan River	Raritan River	Raritan River
Location Identification	RS	TS	WS	RS	TS	WS
Date Collected	2/2/06	2/2/06	2/2/06	2/3/06	2/3/06	2/3/06
Matrix	Solid	Solid	Solid	Solid	Solid	Solid
Analyte/Methods (Units)						
Semi-Volatile Organic Compounds/SW8270C (µg/kg) (continued)						
4,6-Dinitro-2-methylphenol	-	-	-	-	-	-
4-Bromophenyl phenyl ether	-	-	-	-	-	-
4-Chloro-3-methylphenol	-	-	-	-	-	-
4-Chloroaniline	-	-	-	-	-	-
4-Chlorophenyl phenyl ether	-	-	-	-	-	-
4-Methylphenol (p-Cresol)	-	-	-	-	-	-
4-Nitroaniline	-	-	-	-	-	-
4-Nitrophenol	-	-	-	-	-	-
Acenaphthene	<2100	73 T	<1000	<920	200 T	<1200
Acenaphthylene	95 T	120 T	59 T	68 T	210 T	45 T
Acetophenone	-	-	-	-	-	-
Aniline	-	-	-	-	-	-
Anthracene	160 T	220 T	55 T	100 T	480 T	<1200
Atrazine	-	-	-	-	-	-
Benzaldehyde	-	-	-	-	-	-
Benzydine	-	-	-	-	-	-
Benzo(a)anthracene	320 T	500 T	220 T	220 T	1100	100 T
Benzo(a)pyrene	340 T	540	260 T	240 T	970	280 T
Benzo(b)fluoranthene	360 T	520 T	200 T	250 T	980	99 T
Benzo(g,h,i)perylene	310 T	360 T	270 T	180 T	660	<1200
Benzo(k)fluoranthene	130 T	190 T	<1000	98 T	370 T	<1200
Benzoic acid	-	-	-	-	-	-
Benzyl alcohol	-	-	-	-	-	-
Benzyl butyl phthalate	-	-	-	-	-	-
Biphenyl (Diphenyl)	-	-	-	-	-	-

TABLE 2

SEMI-VOLATILE ORGANIC COMPOUNDS SOLID SAMPLE DATA SUMMARY
DEMONSTRATION TESTING AND FULL-SCALE OPERATION OF THE BIOGENESIS SEDIMENT DECONTAMINATION PROCESS
KEASBEY, NEW JERSEY
 (Page 35 of 108)

Field Sample Identification	RS-020206-1800	TS-020206-1801	WS-020206-1802	RS-030206-1200	TS-030206-1201	WS-030206-1202
Sediment Source	Raritan River	Raritan River	Raritan River	Raritan River	Raritan River	Raritan River
Location Identification	RS	TS	WS	RS	TS	WS
Date Collected	2/2/06	2/2/06	2/2/06	2/3/06	2/3/06	2/3/06
Matrix	Solid	Solid	Solid	Solid	Solid	Solid
Analyte/Methods (Units)						
Semi-Volatile Organic Compounds/SW8270C (µg/kg) (continued)						
bis(2-chloroethoxy) Methane	-	-	-	-	-	-
bis(2-chloroethyl) Ether	-	-	-	-	-	-
bis(2-chloroisopropyl) Ether	-	-	-	-	-	-
bis(2-ethylhexyl) Phthalate	-	-	-	-	-	-
Caprolactam	-	-	-	-	-	-
Carbazole	-	-	-	-	-	-
Chrysene	330 T	520 T	350 T	240 T	1100	97 T
Cresols, m	<2100	<530	<1000	<920	<530	<1200
Cresols, Total	-	-	-	-	-	-
Di-n-butyl phthalate	-	-	-	-	-	-
Di-n-octylphthalate	-	-	-	-	-	-
Dibenz(a,h)anthracene	71 T	75 T	84 T	<15	160 T	<20
Dibenzofuran	-	-	-	-	-	-
Diethyl Phthalate	-	-	-	-	-	-
Dimethyl phthalate	-	-	-	-	-	-
Fluoranthene	560 T	980	230 T	370 T	2500	190 T
Fluorene	<2100	74 T	<1000	<920	230 T	<1200
Hexachlorobenzene	<43	<530	<1000	<920	<530	<1200
Hexachlorobutadiene	<2100	<530	<1000	<920	<530	<1200
Hexachlorocyclopentadiene	-	-	-	-	-	-
Hexachloroethane	<2100	<530	<1000	<920	<530	<1200 UJ
Indeno(1,2,3-c,d)Pyrene	280 T	370 T	120 T	160 T	670	<1200
Isophorone	-	-	-	-	-	-
n-Nitroso-di-n-propylamine	-	-	-	-	-	-
n-Nitrosodimethylamine	-	-	-	-	-	-

TABLE 2
SEMI-VOLATILE ORGANIC COMPOUNDS SOLID SAMPLE DATA SUMMARY
DEMONSTRATION TESTING AND FULL-SCALE OPERATION OF THE BIOGENESIS SEDIMENT DECONTAMINATION PROCESS
KEASBEY, NEW JERSEY
(Page 36 of 108)

Field Sample Identification	RS-020206-1800	TS-020206-1801	WS-020206-1802	RS-030206-1200	TS-030206-1201	WS-030206-1202
Sediment Source	Raritan River	Raritan River	Raritan River	Raritan River	Raritan River	Raritan River
Location Identification	RS	TS	WS	RS	TS	WS
Date Collected	2/2/06	2/2/06	2/2/06	2/3/06	2/3/06	2/3/06
Matrix	Solid	Solid	Solid	Solid	Solid	Solid
Analyte/Methods (Units)						
Semi-Volatile Organic Compounds/SW8270C (µg/kg) (continued)						
n-Nitrosodiphenylamine	-	-	-	-	-	-
Naphthalene	140 T	220 T	<1000	<920	400 T	<1200
Nitrobenzene	<2100	<530	<1000	<920	<530	<1200
Pentachlorophenol	<10000	<2600	<5000	<4400	<2600	<5800
Phenanthrene	-	-	-	-	-	-
Phenol	-	-	-	-	-	-
Pyrene	510 T	800	300 T	360 T	1900	160 T
Pyridine	-	-	-	-	-	-

µg/kg micrograms per kilogram.
Italic Italicized result indicates analyte reported to the method detection limit.
Bold Bolded result indicates positively identified compound.
- Not analyzed.
B Analyte detected in an associated blank.
D Sample dilution required for analysis; reported values reflect the dilution.
H Sample holding time was exceeded, but the associated data are considered valid as reported.
J Data are estimated due to associated quality control data.
R Associated quality control did not meet acceptance criteria.
T Analyte was positively identified but the reported concentration is estimated; reported concentration is less than the reporting limit, but greater than the method detection limit.
UJ Potential low bias, possible false negative.

TABLE 2

SEMI-VOLATILE ORGANIC COMPOUNDS SOLID SAMPLE DATA SUMMARY
DEMONSTRATION TESTING AND FULL-SCALE OPERATION OF THE BIOGENESIS SEDIMENT DECONTAMINATION PROCESS
KEASBEY, NEW JERSEY
 (Page 37 of 108)

Field Sample Identification	RS-060206-1930	TS-060206-1931	WS-060206-1932	SP-070206-1445	RS-070206-1630	TS-070206-1631
Sediment Source	Raritan River	Raritan River	Raritan River	Raritan River	Raritan River	Raritan River
Location Identification	RS	TS	WS	PPS	RS	TS
Date Collected	2/6/06	2/6/06	2/6/06	2/7/06	2/7/06	2/7/06
Matrix	Solid	Solid	Solid	Solid	Solid	Solid
Analyte/Methods (Units)						
Semi-Volatile Organic Compounds/SW8270C (µg/kg)						
1,2,4-Trichlorobenzene	-	-	-	-	-	-
1,2-Dichlorobenzene	-	-	-	-	-	-
1,2-Diphenylhydrazine	-	-	-	-	-	-
1,3-Dichlorobenzene	-	-	-	-	-	-
1,4-Dichlorobenzene	<1000	16 T	<1100	<2000 D	<1000	14 T
1,4-Dioxane (p-Dioxane)	-	-	-	-	-	-
2,3,4,6-Tetrachlorophenol	-	-	-	-	-	-
2,3,5,6-Tetrachlorophenol	-	-	-	-	-	-
2,4,5-Trichlorophenol	<1000	<510	<1100	<2000 D	<1000	<520
2,4,6-Trichlorophenol	<1000	<510	<1100	<2000 D	<1000	<520
2,4-Dichlorophenol	-	-	-	-	-	-
2,4-Dimethyl phenol	-	-	-	-	-	-
2,4-Dinitrophenol	-	-	-	-	-	-
2,4-Dinitrotoluene	<1000	<510	<1100	<2000 D	<1000	<520
2,6-Dichlorophenol	-	-	-	-	-	-
2,6-Dinitrotoluene	-	-	-	-	-	-
2-Aminonaphthalene	-	-	-	-	-	-
2-Chloronaphthalene	-	-	-	-	-	-
2-Chlorophenol	-	-	-	-	-	-
2-Methylnaphthalene	-	-	-	-	-	-
2-Methylphenol (o-Cresol)	<1000	<510	<1100	<2000 D	<1000	<520
2-Nitroaniline	-	-	-	-	-	-
2-Nitrophenol	-	-	-	-	-	-
3,3'-Dichlorobenzidine	-	-	-	-	-	-
3-Nitroaniline	-	-	-	-	-	-

TABLE 2

SEMI-VOLATILE ORGANIC COMPOUNDS SOLID SAMPLE DATA SUMMARY
DEMONSTRATION TESTING AND FULL-SCALE OPERATION OF THE BIOGENESIS SEDIMENT DECONTAMINATION PROCESS
KEASBEY, NEW JERSEY
 (Page 38 of 108)

Field Sample Identification	RS-060206-1930	TS-060206-1931	WS-060206-1932	SP-070206-1445	RS-070206-1630	TS-070206-1631
Sediment Source	Raritan River	Raritan River	Raritan River	Raritan River	Raritan River	Raritan River
Location Identification	RS	TS	WS	PPS	RS	TS
Date Collected	2/6/06	2/6/06	2/6/06	2/7/06	2/7/06	2/7/06
Matrix	Solid	Solid	Solid	Solid	Solid	Solid
Analyte/Methods (Units)						
Semi-Volatile Organic Compounds/SW8270C (µg/kg) (continued)						
4,6-Dinitro-2-methylphenol	-	-	-	-	-	-
4-Bromophenyl phenyl ether	-	-	-	-	-	-
4-Chloro-3-methylphenol	-	-	-	-	-	-
4-Chloroaniline	-	-	-	-	-	-
4-Chlorophenyl phenyl ether	-	-	-	-	-	-
4-Methylphenol (p-Cresol)	-	-	-	-	-	-
4-Nitroaniline	-	-	-	-	-	-
4-Nitrophenol	-	-	-	-	-	-
Acenaphthene	25 T	41 T	<1100	110 TD	33 T	35 T
Acenaphthylene	54 T	60 T	<1100	140 TD	39 T	60 T
Acetophenone	-	-	-	-	-	-
Aniline	-	-	-	-	-	-
Anthracene	89 T	120 T	84 T	310 TD	110 T	400 T
Atrazine	-	-	-	-	-	-
Benzaldehyde	-	-	-	-	-	-
Benzydine	-	-	-	-	-	-
Benzo(a)anthracene	220 T	330 T	91 T	400 TD	230 T	390 T
Benzo(a)pyrene	210 T	410 T	96 T	380 TD	250 T	440 T
Benzo(b)fluoranthene	200 T	350 T	90 TJ	360 TD	220 T	380 T
Benzo(g,h,i)perylene	150 T	250 T	<1100	260 TD	170 T	260 T
Benzo(k)fluoranthene	74 T	130 T	26 T	160 TD	85 T	150 T
Benzoic acid	-	-	-	-	-	-
Benzyl alcohol	-	-	-	-	-	-
Benzyl butyl phthalate	-	-	-	-	-	-
Biphenyl (Diphenyl)	-	-	-	-	-	-

TABLE 2

SEMI-VOLATILE ORGANIC COMPOUNDS SOLID SAMPLE DATA SUMMARY
DEMONSTRATION TESTING AND FULL-SCALE OPERATION OF THE BIOGENESIS SEDIMENT DECONTAMINATION PROCESS
KEASBEY, NEW JERSEY
 (Page 39 of 108)

Field Sample Identification	RS-060206-1930	TS-060206-1931	WS-060206-1932	SP-070206-1445	RS-070206-1630	TS-070206-1631
Sediment Source	Raritan River	Raritan River	Raritan River	Raritan River	Raritan River	Raritan River
Location Identification	RS	TS	WS	PPS	RS	TS
Date Collected	2/6/06	2/6/06	2/6/06	2/7/06	2/7/06	2/7/06
Matrix	Solid	Solid	Solid	Solid	Solid	Solid
Analyte/Methods (Units)						
Semi-Volatile Organic Compounds/SW8270C (µg/kg) (continued)						
bis(2-chloroethoxy) Methane	-	-	-	-	-	-
bis(2-chloroethyl) Ether	-	-	-	-	-	-
bis(2-chloroisopropyl) Ether	-	-	-	-	-	-
bis(2-ethylhexyl) Phthalate	-	-	-	-	-	-
Caprolactam	-	-	-	-	-	-
Carbazole	-	-	-	-	-	-
Chrysene	230 T	380 T	100 T	440 TD	240 T	410 T
Cresols, m	<1000	<510	<1100	<2000 D	<1000	<520
Cresols, Total	-	-	-	-	-	-
Di-n-butyl phthalate	-	-	-	-	-	-
Di-n-octylphthalate	-	-	-	-	-	-
Dibenz(a,h)anthracene	<17	58 T	<19	<32 D	50 T	59 T
Dibenzofuran	-	-	-	-	-	-
Diethyl Phthalate	-	-	-	-	-	-
Dimethyl phthalate	-	-	-	-	-	-
Fluoranthene	330 T	490 T	170 T	600 TD	310 T	570
Fluorene	<1000	43 T	<1100 UJ	120 TD	33 T	71 T
Hexachlorobenzene	<1000	<510	<1100	<2000 D	<1000	<520
Hexachlorobutadiene	<1000	<510	<1100	<2000 D	<1000	<520
Hexachlorocyclopentadiene	-	-	-	-	-	-
Hexachloroethane	<1000	<510	<1100 UJ	<2000 D	<1000	<520
Indeno(1,2,3-c,d)Pyrene	140 T	210 T	<1100	240 TD	<1000	210 T
Isophorone	-	-	-	-	-	-
n-Nitroso-di-n-propylamine	-	-	-	-	-	-
n-Nitrosodimethylamine	-	-	-	-	-	-

TABLE 2
SEMI-VOLATILE ORGANIC COMPOUNDS SOLID SAMPLE DATA SUMMARY
DEMONSTRATION TESTING AND FULL-SCALE OPERATION OF THE BIOGENESIS SEDIMENT DECONTAMINATION PROCESS
KEASBEY, NEW JERSEY
(Page 40 of 108)

Field Sample Identification	RS-060206-1930	TS-060206-1931	WS-060206-1932	SP-070206-1445	RS-070206-1630	TS-070206-1631
Sediment Source	Raritan River	Raritan River	Raritan River	Raritan River	Raritan River	Raritan River
Location Identification	RS	TS	WS	PPS	RS	TS
Date Collected	2/6/06	2/6/06	2/6/06	2/7/06	2/7/06	2/7/06
Matrix	Solid	Solid	Solid	Solid	Solid	Solid
Analyte/Methods (Units)						
Semi-Volatile Organic Compounds/SW8270C (µg/kg) (continued)						
n-Nitrosodiphenylamine	-	-	-	-	-	-
Naphthalene	<1000	150 T	<1100	<2000 D	90 T	170 T
Nitrobenzene	<1000	<510	<1100	<2000 D	<1000	<520
Pentachlorophenol	<4900	<2500	<5500	<9500 D	<5100	<2500
Phenanthrene	-	-	-	-	-	-
Phenol	-	-	-	-	-	-
Pyrene	390 T	560	170 T	860 TD	360 T	530
Pyridine	-	-	-	-	-	-

µg/kg micrograms per kilogram.
Italic Italicized result indicates analyte reported to the method detection limit.
Bold Bolded result indicates positively identified compound.
- Not analyzed.
B Analyte detected in an associated blank.
D Sample dilution required for analysis; reported values reflect the dilution.
H Sample holding time was exceeded, but the associated data are considered valid as reported.
J Data are estimated due to associated quality control data.
R Associated quality control did not meet acceptance criteria.
T Analyte was positively identified but the reported concentration is estimated; reported concentration is less than the reporting limit, but greater than the method detection limit.
UJ Potential low bias, possible false negative.

TABLE 2

SEMI-VOLATILE ORGANIC COMPOUNDS SOLID SAMPLE DATA SUMMARY
DEMONSTRATION TESTING AND FULL-SCALE OPERATION OF THE BIOGENESIS SEDIMENT DECONTAMINATION PROCESS
KEASBEY, NEW JERSEY
 (Page 41 of 108)

Field Sample Identification	TS-070206-1631 DRIED	WS-070206-1632	RS-080206-1700	TS-080206-1701	WS-080206-1702	RS-090206-2300
Sediment Source	Raritan River	Raritan River	Raritan River	Raritan River	Raritan River	Arthur Kill
Location Identification	TS	WS	RS	TS	WS	RS
Date Collected	2/7/06	2/7/06	2/8/06	2/8/06	2/8/06	2/9/06
Matrix	Solid	Solid	Solid	Solid	Solid	Solid
Analyte/Methods (Units)						
Semi-Volatile Organic Compounds/SW8270C (µg/kg)						
1,2,4-Trichlorobenzene	-	-	-	-	-	-
1,2-Dichlorobenzene	-	-	-	-	-	-
1,2-Diphenylhydrazine	-	-	-	-	-	-
1,3-Dichlorobenzene	-	-	-	-	-	-
1,4-Dichlorobenzene	<2100 DH	<1100	<970	<510	<1200	130 T
1,4-Dioxane (p-Dioxane)	-	-	-	-	-	-
2,3,4,6-Tetrachlorophenol	-	-	-	-	-	-
2,3,5,6-Tetrachlorophenol	-	-	-	-	-	-
2,4,5-Trichlorophenol	<2100 DH	<1100	<970	<510	<1200	<1000
2,4,6-Trichlorophenol	<2100 DH	<1100	<970	<510	<1200	<1000
2,4-Dichlorophenol	-	-	-	-	-	-
2,4-Dimethyl phenol	-	-	-	-	-	-
2,4-Dinitrophenol	-	-	-	-	-	-
2,4-Dinitrotoluene	<2100 DH	<1100	<970	<510	<1200	<1000
2,6-Dichlorophenol	-	-	-	-	-	-
2,6-Dinitrotoluene	-	-	-	-	-	-
2-Aminonaphthalene	-	-	-	-	-	-
2-Chloronaphthalene	-	-	-	-	-	-
2-Chlorophenol	-	-	-	-	-	-
2-Methylnaphthalene	-	-	-	-	-	-
2-Methylphenol (o-Cresol)	<2100 D	<1100	<970	<510	<1200	<1000
2-Nitroaniline	-	-	-	-	-	-
2-Nitrophenol	-	-	-	-	-	-
3,3'-Dichlorobenzidine	-	-	-	-	-	-
3-Nitroaniline	-	-	-	-	-	-

TABLE 2

SEMI-VOLATILE ORGANIC COMPOUNDS SOLID SAMPLE DATA SUMMARY
DEMONSTRATION TESTING AND FULL-SCALE OPERATION OF THE BIOGENESIS SEDIMENT DECONTAMINATION PROCESS
KEASBEY, NEW JERSEY
 (Page 42 of 108)

Field Sample Identification	TS-070206-1631 DRIED	WS-070206-1632	RS-080206-1700	TS-080206-1701	WS-080206-1702	RS-090206-2300
Sediment Source	Raritan River	Raritan River	Raritan River	Raritan River	Raritan River	Arthur Kill
Location Identification	TS	WS	RS	TS	WS	RS
Date Collected	2/7/06	2/7/06	2/8/06	2/8/06	2/8/06	2/9/06
Matrix	Solid	Solid	Solid	Solid	Solid	Solid
Analyte/Methods (Units)						
Semi-Volatile Organic Compounds/SW8270C (µg/kg) (continued)						
4,6-Dinitro-2-methylphenol	-	-	-	-	-	-
4-Bromophenyl phenyl ether	-	-	-	-	-	-
4-Chloro-3-methylphenol	-	-	-	-	-	-
4-Chloroaniline	-	-	-	-	-	-
4-Chlorophenyl phenyl ether	-	-	-	-	-	-
4-Methylphenol (p-Cresol)	-	-	-	-	-	-
4-Nitroaniline	-	-	-	-	-	-
4-Nitrophenol	-	-	-	-	-	-
Acenaphthene	76 TD	39 T	46 T	23 T	40 T	250 T
Acenaphthylene	140 TD	33 T	110 T	62 T	56 T	530 T
Acetophenone	-	-	-	-	-	-
Aniline	-	-	-	-	-	-
Anthracene	320 TD	<1100	170 T	98 T	100 T	770 T
Atrazine	-	-	-	-	-	-
Benzaldehyde	-	-	-	-	-	-
Benzidine	-	-	-	-	-	-
Benzo(a)anthracene	750 TD	130 T	400 T	250 T	170 T	1300
Benzo(a)pyrene	670 TD	<19	410 T	250 T	110 T	1100
Benzo(b)fluoranthene	590 TD	100 T	390 T	220 T	140 T	1000
Benzo(g,h,i)perylene	560 TD	<1100	290 T	190 T	100 T	560 T
Benzo(k)fluoranthene	170 TD	<1100	170 T	100 T	44 T	420 T
Benzoic acid	-	-	-	-	-	-
Benzyl alcohol	-	-	-	-	-	-
Benzyl butyl phthalate	-	-	-	-	-	-
Biphenyl (Diphenyl)	-	-	-	-	-	-

TABLE 2

SEMI-VOLATILE ORGANIC COMPOUNDS SOLID SAMPLE DATA SUMMARY
DEMONSTRATION TESTING AND FULL-SCALE OPERATION OF THE BIOGENESIS SEDIMENT DECONTAMINATION PROCESS
KEASBEY, NEW JERSEY
 (Page 43 of 108)

Field Sample Identification	TS-070206-1631 DRIED	WS-070206-1632	RS-080206-1700	TS-080206-1701	WS-080206-1702	RS-090206-2300
Sediment Source	Raritan River	Raritan River	Raritan River	Raritan River	Raritan River	Arthur Kill
Location Identification	TS	WS	RS	TS	WS	RS
Date Collected	2/7/06	2/7/06	2/8/06	2/8/06	2/8/06	2/9/06
Matrix	Solid	Solid	Solid	Solid	Solid	Solid
Analyte/Methods (Units)						
Semi-Volatile Organic Compounds/SW8270C (µg/kg) (continued)						
bis(2-chloroethoxy) Methane	-	-	-	-	-	-
bis(2-chloroethyl) Ether	-	-	-	-	-	-
bis(2-chloroisopropyl) Ether	-	-	-	-	-	-
bis(2-ethylhexyl) Phthalate	-	-	-	-	-	-
Caprolactam	-	-	-	-	-	-
Carbazole	-	-	-	-	-	-
Chrysene	840 TD	130 T	430 T	260 T	180 T	1400
Cresols, m	<2100 D	<1100	<970	<510	<1200	<1000
Cresols, Total	-	-	-	-	-	-
Di-n-butyl phthalate	-	-	-	-	-	-
Di-n-octylphthalate	-	-	-	-	-	-
Dibenz(a,h)anthracene	<35 D	<19	67 T	34 T	<19	140 T
Dibenzofuran	-	-	-	-	-	-
Diethyl Phthalate	-	-	-	-	-	-
Dimethyl phthalate	-	-	-	-	-	-
Fluoranthene	1100 TD	190 T	610 T	350 T	300 T	2400
Fluorene	100 TD	<1100	68 T	33 T	<1200	370 T
Hexachlorobenzene	<43 DH	<1100	<970	<510	<1200	<1000
Hexachlorobutadiene	<2100 DH	<1100 UJ	<970	<510	<1200	<1000
Hexachlorocyclopentadiene	-	-	-	-	-	-
Hexachloroethane	<2100 DH	<1100	<970	<510	<1200	<1000
Indeno(1,2,3-c,d)Pyrene	410 TD	<1100	280 T	180 T	100 T	590 T
Isophorone	-	-	-	-	-	-
n-Nitroso-di-n-propylamine	-	-	-	-	-	-
n-Nitrosodimethylamine	-	-	-	-	-	-

TABLE 2

SEMI-VOLATILE ORGANIC COMPOUNDS SOLID SAMPLE DATA SUMMARY
DEMONSTRATION TESTING AND FULL-SCALE OPERATION OF THE BIOGENESIS SEDIMENT DECONTAMINATION PROCESS
KEASBEY, NEW JERSEY
 (Page 44 of 108)

Field Sample Identification	TS-070206-1631 DRIED	WS-070206-1632	RS-080206-1700	TS-080206-1701	WS-080206-1702	RS-090206-2300
Sediment Source	Raritan River	Raritan River	Raritan River	Raritan River	Raritan River	Arthur Kill
Location Identification	TS	WS	RS	TS	WS	RS
Date Collected	2/7/06	2/7/06	2/8/06	2/8/06	2/8/06	2/9/06
Matrix	Solid	Solid	Solid	Solid	Solid	Solid
Analyte/Methods (Units)						
Semi-Volatile Organic Compounds/SW8270C (µg/kg) (continued)						
n-Nitrosodiphenylamine	-	-	-	-	-	-
Naphthalene	230 TD	<1100 UJ	130 T	97 T	<1200 UJ	400 T
Nitrobenzene	<2100 DH	<1100 UJ	<970	<510	<1200	<1000
Pentachlorophenol	<10000 DH	<5500	<4700	<2500	<5600	<4900
Phenanthrene	-	-	-	-	-	-
Phenol	-	-	-	-	-	-
Pyrene	1200 TD	260 T	770 T	470 T	360 T	2800
Pyridine	-	-	-	-	-	-

µg/kg micrograms per kilogram.

Italic Italicized result indicates analyte reported to the method detection limit.

Bold Bolded result indicates positively identified compound.

- Not analyzed.

B Analyte detected in an associated blank.

D Sample dilution required for analysis; reported values reflect the dilution.

H Sample holding time was exceeded, but the associated data are considered valid as reported.

J Data are estimated due to associated quality control data.

R Associated quality control did not meet acceptance criteria.

T Analyte was positively identified but the reported concentration is estimated; reported concentration is less than the reporting limit, but greater than the method detection limit.

UJ Potential low bias, possible false negative.

TABLE 2

SEMI-VOLATILE ORGANIC COMPOUNDS SOLID SAMPLE DATA SUMMARY
DEMONSTRATION TESTING AND FULL-SCALE OPERATION OF THE BIOGENESIS SEDIMENT DECONTAMINATION PROCESS
KEASBEY, NEW JERSEY
 (Page 45 of 108)

Field Sample Identification	TS-090206-2301	WS-090206-2302	RS-130206-1700	TS-130206-1701	WS-130206-1702	RS-140206-1330
Sediment Source	Arthur Kill	Arthur Kill	Lower Passaic River	Lower Passaic River	Lower Passaic River	Arthur Kill
Location Identification	TS	WS	RS	TS	WS	RS
Date Collected	2/9/06	2/9/06	2/13/06	2/13/06	2/13/06	2/14/06
Matrix	Solid	Solid	Solid	Solid	Solid	Solid
Analyte/Methods (Units)						
Semi-Volatile Organic Compounds/SW8270C (µg/kg)						
1,2,4-Trichlorobenzene	-	-	-	-	-	-
1,2-Dichlorobenzene	-	-	-	-	-	-
1,2-Diphenylhydrazine	-	-	-	-	-	-
1,3-Dichlorobenzene	-	-	-	-	-	-
1,4-Dichlorobenzene	80 T	<1100	<3400 D	<5400 D	<6800 D	<6400 D
1,4-Dioxane (p-Dioxane)	-	-	-	-	-	-
2,3,4,6-Tetrachlorophenol	-	-	-	-	-	-
2,3,5,6-Tetrachlorophenol	-	-	-	-	-	-
2,4,5-Trichlorophenol	<510	<1100	<3400 D	<5400 D	<6800 D	<6400 D
2,4,6-Trichlorophenol	<510	<1100	<3400 D	<5400 D	<6800 D	<6400 D
2,4-Dichlorophenol	-	-	-	-	-	-
2,4-Dimethyl phenol	-	-	-	-	-	-
2,4-Dinitrophenol	-	-	-	-	-	-
2,4-Dinitrotoluene	<510	<1100	<3400 D	<57 D	<72 D	<67 D
2,6-Dichlorophenol	-	-	-	-	-	-
2,6-Dinitrotoluene	-	-	-	-	-	-
2-Aminonaphthalene	-	-	-	-	-	-
2-Chloronaphthalene	-	-	-	-	-	-
2-Chlorophenol	-	-	-	-	-	-
2-Methylnaphthalene	-	-	-	-	-	-
2-Methylphenol (o-Cresol)	<510	<1100	<3400 D	<5400 D	<6800 D	<6400 D
2-Nitroaniline	-	-	-	-	-	-
2-Nitrophenol	-	-	-	-	-	-
3,3'-Dichlorobenzidine	-	-	-	-	-	-
3-Nitroaniline	-	-	-	-	-	-

TABLE 2

SEMI-VOLATILE ORGANIC COMPOUNDS SOLID SAMPLE DATA SUMMARY
DEMONSTRATION TESTING AND FULL-SCALE OPERATION OF THE BIOGENESIS SEDIMENT DECONTAMINATION PROCESS
KEASBEY, NEW JERSEY
 (Page 46 of 108)

Field Sample Identification	TS-090206-2301	WS-090206-2302	RS-130206-1700	TS-130206-1701	WS-130206-1702	RS-140206-1330
Sediment Source	Arthur Kill	Arthur Kill	Lower Passaic River	Lower Passaic River	Lower Passaic River	Arthur Kill
Location Identification	TS	WS	RS	TS	WS	RS
Date Collected	2/9/06	2/9/06	2/13/06	2/13/06	2/13/06	2/14/06
Matrix	Solid	Solid	Solid	Solid	Solid	Solid
Analyte/Methods (Units)						
Semi-Volatile Organic Compounds/SW8270C (µg/kg) (continued)						
4,6-Dinitro-2-methylphenol	-	-	-	-	-	-
4-Bromophenyl phenyl ether	-	-	-	-	-	-
4-Chloro-3-methylphenol	-	-	-	-	-	-
4-Chloroaniline	-	-	-	-	-	-
4-Chlorophenyl phenyl ether	-	-	-	-	-	-
4-Methylphenol (p-Cresol)	-	-	-	-	-	-
4-Nitroaniline	-	-	-	-	-	-
4-Nitrophenol	-	-	-	-	-	-
Acenaphthene	95 T	100 T	<3400 D	280 TD	240 TD	430 TD
Acenaphthylene	190 T	130 T	<3400 D	500 TD	210 TD	510 TD
Acetophenone	-	-	-	-	-	-
Aniline	-	-	-	-	-	-
Anthracene	320 T	300 T	210 TD	680 TD	530 TD	920 TD
Atrazine	-	-	-	-	-	-
Benzaldehyde	-	-	-	-	-	-
Benzdine	-	-	-	-	-	-
Benzo(a)anthracene	590	380 T	490 TD	1600 TD	740 TD	1400 TD
Benzo(a)pyrene	590	320 T	500 TD	1300 TD	510 TD	1100 TD
Benzo(b)fluoranthene	550	330 T	540 TD	1300 TDJ	550 TD	1100 TD
Benzo(g,h,i)perylene	320 T	160 T	350 TD	850 TD	350 TD	720 TD
Benzo(k)fluoranthene	220 T	130 T	170 TD	480 TD	230 TD	440 TD
Benzoic acid	-	-	-	-	-	-
Benzyl alcohol	-	-	-	-	-	-
Benzyl butyl phthalate	-	-	-	-	-	-
Biphenyl (Diphenyl)	-	-	-	-	-	-

TABLE 2

SEMI-VOLATILE ORGANIC COMPOUNDS SOLID SAMPLE DATA SUMMARY
DEMONSTRATION TESTING AND FULL-SCALE OPERATION OF THE BIOGENESIS SEDIMENT DECONTAMINATION PROCESS
KEASBEY, NEW JERSEY
 (Page 47 of 108)

Field Sample Identification	TS-090206-2301	WS-090206-2302	RS-130206-1700	TS-130206-1701	WS-130206-1702	RS-140206-1330
Sediment Source	Arthur Kill	Arthur Kill	Lower Passaic River	Lower Passaic River	Lower Passaic River	Arthur Kill
Location Identification	TS	WS	RS	TS	WS	RS
Date Collected	2/9/06	2/9/06	2/13/06	2/13/06	2/13/06	2/14/06
Matrix	Solid	Solid	Solid	Solid	Solid	Solid
Analyte/Methods (Units)						
Semi-Volatile Organic Compounds/SW8270C (µg/kg) (continued)						
bis(2-chloroethoxy) Methane	-	-	-	-	-	-
bis(2-chloroethyl) Ether	-	-	-	-	-	-
bis(2-chloroisopropyl) Ether	-	-	-	-	-	-
bis(2-ethylhexyl) Phthalate	-	-	-	-	-	-
Caprolactam	-	-	-	-	-	-
Carbazole	-	-	-	-	-	-
Chrysene	680	460 T	750 TD	2000 TD	620 TD	1700 TD
Cresols, m	<510	<1100	<3400 D	<5400 D	<6800 D	<6400 D
Cresols, Total	-	-	-	-	-	-
Di-n-butyl phthalate	-	-	-	-	-	-
Di-n-octylphthalate	-	-	-	-	-	-
Dibenz(a,h)anthracene	78 T	44 T	<56 D	<89 D	<110 D	<100 D
Dibenzofuran	-	-	-	-	-	-
Diethyl Phthalate	-	-	-	-	-	-
Dimethyl phthalate	-	-	-	-	-	-
Fluoranthene	930	760 T	1200 TD	3000 TDJ	1700 TD	3000 TDJ
Fluorene	110 T	110 T	<3400 D	360 TD	190 TD	390 TD
Hexachlorobenzene	<510	<1100	<69 D	<110 D	<140 D	<130 D
Hexachlorobutadiene	<510	<1100	<3400 D	<5400 D	<6800 D	<6400 D
Hexachlorocyclopentadiene	-	-	-	-	-	-
Hexachloroethane	<510	<1100	<3400 D	<5400 D	<6800 D	<6400 D
Indeno(1,2,3-c,d)Pyrene	320 T	160 T	260 TD	690 TD	280 TD	560 TD
Isophorone	-	-	-	-	-	-
n-Nitroso-di-n-propylamine	-	-	-	-	-	-
n-Nitrosodimethylamine	-	-	-	-	-	-

TABLE 2

SEMI-VOLATILE ORGANIC COMPOUNDS SOLID SAMPLE DATA SUMMARY
DEMONSTRATION TESTING AND FULL-SCALE OPERATION OF THE BIOGENESIS SEDIMENT DECONTAMINATION PROCESS
KEASBEY, NEW JERSEY
 (Page 48 of 108)

Field Sample Identification	TS-090206-2301	WS-090206-2302	RS-130206-1700	TS-130206-1701	WS-130206-1702	RS-140206-1330
Sediment Source	Arthur Kill	Arthur Kill	Lower Passaic River	Lower Passaic River	Lower Passaic River	Arthur Kill
Location Identification	TS	WS	RS	TS	WS	RS
Date Collected	2/9/06	2/9/06	2/13/06	2/13/06	2/13/06	2/14/06
Matrix	Solid	Solid	Solid	Solid	Solid	Solid
Analyte/Methods (Units)						
Semi-Volatile Organic Compounds/SW8270C (µg/kg) (continued)						
n-Nitrosodiphenylamine	-	-	-	-	-	-
Naphthalene	220 T	<1100	<3400 D	480 TD	230 TD	550 TD
Nitrobenzene	<510	<1100	<3400 D	<5400 D	<6800 D	<6400 D
Pentachlorophenol	<2500	<5200	<17000 D	<7500 D	<9400 D	<8800 D
Phenanthrene	-	-	-	-	-	-
Phenol	-	-	-	-	-	-
Pyrene	1100	980 T	970 TD	3000 TD	1800 TD	2800 TD
Pyridine	-	-	-	-	-	-

µg/kg micrograms per kilogram.

Italic Italicized result indicates analyte reported to the method detection limit.

Bold Bolded result indicates positively identified compound.

- Not analyzed.

B Analyte detected in an associated blank.

D Sample dilution required for analysis; reported values reflect the dilution.

H Sample holding time was exceeded, but the associated data are considered valid as reported.

J Data are estimated due to associated quality control data.

R Associated quality control did not meet acceptance criteria.

T Analyte was positively identified but the reported concentration is estimated; reported concentration is less than the reporting limit, but greater than the method detection limit.

UJ Potential low bias, possible false negative.

TABLE 2

SEMI-VOLATILE ORGANIC COMPOUNDS SOLID SAMPLE DATA SUMMARY
DEMONSTRATION TESTING AND FULL-SCALE OPERATION OF THE BIOGENESIS SEDIMENT DECONTAMINATION PROCESS
KEASBEY, NEW JERSEY
 (Page 49 of 108)

Field Sample Identification	TS-140206-1331	WS-140206-1332	RS-160206-1500	TS-160206-1501	WS-160206-1502	RS-170206-1100
Sediment Source	Arthur Kill	Arthur Kill	Arthur Kill	Arthur Kill	Arthur Kill	Arthur Kill
Location Identification	TS	WS	RS	TS	WS	RS
Date Collected	2/14/06	2/14/06	2/16/06	2/16/06	2/16/06	2/17/06
Matrix	Solid	Solid	Solid	Solid	Solid	Solid
Analyte/Methods (Units)						
Semi-Volatile Organic Compounds/SW8270C (µg/kg)						
1,2,4-Trichlorobenzene	-	-	-	-	-	-
1,2-Dichlorobenzene	-	-	-	-	-	-
1,2-Diphenylhydrazine	-	-	-	-	-	-
1,3-Dichlorobenzene	-	-	-	-	-	-
1,4-Dichlorobenzene	110 TD	<6000 D	130 TD	130 TD	<2800 D	<3600 DJ
1,4-Dioxane (p-Dioxane)	-	-	-	-	-	-
2,3,4,6-Tetrachlorophenol	-	-	-	-	-	-
2,3,5,6-Tetrachlorophenol	-	-	-	-	-	-
2,4,5-Trichlorophenol	<4400 D	<6000 D	<2500 D	<1200 D	<2800 D	<3600 DJ
2,4,6-Trichlorophenol	<4400 D	<6000 D	<2500 D	<1200 D	<2800 D	<3600 DJ
2,4-Dichlorophenol	-	-	-	-	-	-
2,4-Dimethyl phenol	-	-	-	-	-	-
2,4-Dinitrophenol	-	-	-	-	-	-
2,4-Dinitrotoluene	<47 D	<63 D	<2500 D	<1200 D	<2800 D	<3600 DJ
2,6-Dichlorophenol	-	-	-	-	-	-
2,6-Dinitrotoluene	-	-	-	-	-	-
2-Aminonaphthalene	-	-	-	-	-	-
2-Chloronaphthalene	-	-	-	-	-	-
2-Chlorophenol	-	-	-	-	-	-
2-Methylnaphthalene	-	-	-	-	-	-
2-Methylphenol (o-Cresol)	<4400 D	<6000 D	<2500 D	<1200 D	<2800 D	<3600 DJ
2-Nitroaniline	-	-	-	-	-	-
2-Nitrophenol	-	-	-	-	-	-
3,3'-Dichlorobenzidine	-	-	-	-	-	-
3-Nitroaniline	-	-	-	-	-	-

TABLE 2

SEMI-VOLATILE ORGANIC COMPOUNDS SOLID SAMPLE DATA SUMMARY
DEMONSTRATION TESTING AND FULL-SCALE OPERATION OF THE BIOGENESIS SEDIMENT DECONTAMINATION PROCESS
KEASBEY, NEW JERSEY
 (Page 50 of 108)

Field Sample Identification	TS-140206-1331	WS-140206-1332	RS-160206-1500	TS-160206-1501	WS-160206-1502	RS-170206-1100
Sediment Source	Arthur Kill	Arthur Kill	Arthur Kill	Arthur Kill	Arthur Kill	Arthur Kill
Location Identification	TS	WS	RS	TS	WS	RS
Date Collected	2/14/06	2/14/06	2/16/06	2/16/06	2/16/06	2/17/06
Matrix	Solid	Solid	Solid	Solid	Solid	Solid
Analyte/Methods (Units)						
Semi-Volatile Organic Compounds/SW8270C (µg/kg) (continued)						
4,6-Dinitro-2-methylphenol	-	-	-	-	-	-
4-Bromophenyl phenyl ether	-	-	-	-	-	-
4-Chloro-3-methylphenol	-	-	-	-	-	-
4-Chloroaniline	-	-	-	-	-	-
4-Chlorophenyl phenyl ether	-	-	-	-	-	-
4-Methylphenol (p-Cresol)	-	-	-	-	-	-
4-Nitroaniline	-	-	-	-	-	-
4-Nitrophenol	-	-	-	-	-	-
Acenaphthene	230 TD	190 TD	250 TD	210 TD	140 TD	390 TDJ
Acenaphthylene	400 TD	200 TD	270 TD	270 TD	94 TD	410 TDJ
Acetophenone	-	-	-	-	-	-
Aniline	-	-	-	-	-	-
Anthracene	550 TD	390 TD	660 TD	570 TD	260 TD	750 TDJ
Atrazine	-	-	-	-	-	-
Benzaldehyde	-	-	-	-	-	-
Benzidine	-	-	-	-	-	-
Benzo(a)anthracene	1100 TD	650 TD	1200 TD	1000 TD	370 TD	1300 TDJ
Benzo(a)pyrene	870 TD	510 TD	1100 TD	870 TD	260 TD	950 TDJ
Benzo(b)fluoranthene	800 TDJ	510 TD	1000 TD	840 TD	280 TD	1100 TDJ
Benzo(g,h,i)perylene	550 TD	300 TD	650 TD	470 TDJ	120 TD	670 TDJ
Benzo(k)fluoranthene	330 TD	190 TD	440 TD	310 TD	89 TD	410 TDJ
Benzoic acid	-	-	-	-	-	-
Benzyl alcohol	-	-	-	-	-	-
Benzyl butyl phthalate	-	-	-	-	-	-
Biphenyl (Diphenyl)	-	-	-	-	-	-

TABLE 2

SEMI-VOLATILE ORGANIC COMPOUNDS SOLID SAMPLE DATA SUMMARY
DEMONSTRATION TESTING AND FULL-SCALE OPERATION OF THE BIOGENESIS SEDIMENT DECONTAMINATION PROCESS
KEASBEY, NEW JERSEY
 (Page 51 of 108)

Field Sample Identification	TS-140206-1331	WS-140206-1332	RS-160206-1500	TS-160206-1501	WS-160206-1502	RS-170206-1100
Sediment Source	Arthur Kill	Arthur Kill	Arthur Kill	Arthur Kill	Arthur Kill	Arthur Kill
Location Identification	TS	WS	RS	TS	WS	RS
Date Collected	2/14/06	2/14/06	2/16/06	2/16/06	2/16/06	2/17/06
Matrix	Solid	Solid	Solid	Solid	Solid	Solid
Analyte/Methods (Units)						
Semi-Volatile Organic Compounds/SW8270C (µg/kg) (continued)						
bis(2-chloroethoxy) Methane	-	-	-	-	-	-
bis(2-chloroethyl) Ether	-	-	-	-	-	-
bis(2-chloroisopropyl) Ether	-	-	-	-	-	-
bis(2-ethylhexyl) Phthalate	-	-	-	-	-	-
Caprolactam	-	-	-	-	-	-
Carbazole	-	-	-	-	-	-
Chrysene	1200 TD	800 TD	1400 TD	1200 D	420 TD	1500 TDJ
Cresols, m	<4400 D	3700 TD	<2500 D	<1200 D	<2800 D	<3600 DJ
Cresols, Total	-	-	-	-	-	-
Di-n-butyl phthalate	-	-	-	-	-	-
Di-n-octylphthalate	-	-	-	-	-	-
Dibenz(a,h)anthracene	<73 D	<99 D	140 TD	110 TD	<47 D	<59 DJ
Dibenzofuran	-	-	-	-	-	-
Diethyl Phthalate	-	-	-	-	-	-
Dimethyl phthalate	-	-	-	-	-	-
Fluoranthene	2100 TDJ	1500 TDJ	2000 TD	1800 DJ	810 TD	2900 TDJ
Fluorene	310 TD	150 TD	240 TD	210 TD	94 TD	260 TDJ
Hexachlorobenzene	<90 D	<120 D	<51 D	<1200 D	<57 D	<73 DJ
Hexachlorobutadiene	<4400 D	<6000 D	<2500 D	<1200 D	<2800 D	<3600 DJ
Hexachlorocyclopentadiene	-	-	-	-	-	-
Hexachloroethane	<4400 DUJ	<6000 D	<2500 D	<1200 DUJ	<2800 D	<3600 DJ
Indeno(1,2,3-c,d)Pyrene	430 TDJ	240 TD	490 TD	370 TD	100 TD	590 TDJ
Isophorone	-	-	-	-	-	-
n-Nitroso-di-n-propylamine	-	-	-	-	-	-
n-Nitrosodimethylamine	-	-	-	-	-	-

TABLE 2

SEMI-VOLATILE ORGANIC COMPOUNDS SOLID SAMPLE DATA SUMMARY
DEMONSTRATION TESTING AND FULL-SCALE OPERATION OF THE BIOGENESIS SEDIMENT DECONTAMINATION PROCESS
KEASBEY, NEW JERSEY
 (Page 52 of 108)

Field Sample Identification	TS-140206-1331	WS-140206-1332	RS-160206-1500	TS-160206-1501	WS-160206-1502	RS-170206-1100
Sediment Source	Arthur Kill	Arthur Kill	Arthur Kill	Arthur Kill	Arthur Kill	Arthur Kill
Location Identification	TS	WS	RS	TS	WS	RS
Date Collected	2/14/06	2/14/06	2/16/06	2/16/06	2/16/06	2/17/06
Matrix	Solid	Solid	Solid	Solid	Solid	Solid
Analyte/Methods (Units)						
Semi-Volatile Organic Compounds/SW8270C (µg/kg) (continued)						
n-Nitrosodiphenylamine	-	-	-	-	-	-
Naphthalene	380 TD	<6000 D	420 TD	480 TD	190 TD	540 TDJ
Nitrobenzene	<4400 D	<6000 D	<2500 D	<1200 D	<2800 D	<3600 DJ
Pentachlorophenol	<21000 D	<8300 D	<12000 D	<6000 D	<14000 D	<17000 DJ
Phenanthrene	-	-	-	-	-	-
Phenol	-	-	-	-	-	-
Pyrene	2100 TD	1400 TD	2100 TD	1700 D	770 TD	3400 TDJ
Pyridine	-	-	-	-	-	-

µg/kg micrograms per kilogram.

Italic Italicized result indicates analyte reported to the method detection limit.

Bold Bolded result indicates positively identified compound.

- Not analyzed.

B Analyte detected in an associated blank.

D Sample dilution required for analysis; reported values reflect the dilution.

H Sample holding time was exceeded, but the associated data are considered valid as reported.

J Data are estimated due to associated quality control data.

R Associated quality control did not meet acceptance criteria.

T Analyte was positively identified but the reported concentration is estimated; reported concentration is less than the reporting limit, but greater than the method detection limit.

UJ Potential low bias, possible false negative.

TABLE 2

SEMI-VOLATILE ORGANIC COMPOUNDS SOLID SAMPLE DATA SUMMARY
DEMONSTRATION TESTING AND FULL-SCALE OPERATION OF THE BIOGENESIS SEDIMENT DECONTAMINATION PROCESS
KEASBEY, NEW JERSEY
 (Page 53 of 108)

Field Sample Identification	TS-170206-1101	WS-170206-1102	TS-230206-0930	TS-230206-0930 DRIED	RS-270206-1400	TS-270206-1350
Sediment Source	Arthur Kill	Arthur Kill	Arthur Kill	Arthur Kill	Lower Passaic River	Lower Passaic River
Location Identification	TS	WS	TS	TS	RS	TS
Date Collected	2/17/06	2/17/06	2/23/06	2/23/06	2/27/06	2/27/06
Matrix	Solid	Solid	Solid	Solid	Solid	Solid
Analyte/Methods (Units)						
Semi-Volatile Organic Compounds/SW8270C (µg/kg)						
1,2,4-Trichlorobenzene	-	-	-	-	-	-
1,2-Dichlorobenzene	-	-	-	-	-	-
1,2-Diphenylhydrazine	-	-	-	-	-	-
1,3-Dichlorobenzene	-	-	-	-	-	-
1,4-Dichlorobenzene	150 TDJ	61 TD	100 TD	93 TD	160 TD	110 TD
1,4-Dioxane (p-Dioxane)	-	-	-	-	-	-
2,3,4,6-Tetrachlorophenol	-	-	-	-	-	-
2,3,5,6-Tetrachlorophenol	-	-	-	-	-	-
2,4,5-Trichlorophenol	<1100 DJ	<2700 D	<2300 D	<2400 D	<2700 D	<1200 D
2,4,6-Trichlorophenol	<1100 DJ	<2700 D	<2300 D	<2400 D	<2700 D	<1200 D
2,4-Dichlorophenol	-	-	-	-	-	-
2,4-Dimethyl phenol	-	-	-	-	-	-
2,4-Dinitrophenol	-	-	-	-	-	-
2,4-Dinitrotoluene	<1100 DJ	<2700 D	<2300 D	<2400 D	<2700 D	<1200 D
2,6-Dichlorophenol	-	-	-	-	-	-
2,6-Dinitrotoluene	-	-	-	-	-	-
2-Aminonaphthalene	-	-	-	-	-	-
2-Chloronaphthalene	-	-	-	-	-	-
2-Chlorophenol	-	-	-	-	-	-
2-Methylnaphthalene	-	-	-	-	-	-
2-Methylphenol (o-Cresol)	<1100 DJ	<2700 D	<2300 D	<2400 D	<2700 D	<1200 DUJ
2-Nitroaniline	-	-	-	-	-	-
2-Nitrophenol	-	-	-	-	-	-
3,3'-Dichlorobenzidine	-	-	-	-	-	-
3-Nitroaniline	-	-	-	-	-	-

TABLE 2

SEMI-VOLATILE ORGANIC COMPOUNDS SOLID SAMPLE DATA SUMMARY
DEMONSTRATION TESTING AND FULL-SCALE OPERATION OF THE BIOGENESIS SEDIMENT DECONTAMINATION PROCESS
KEASBEY, NEW JERSEY
 (Page 54 of 108)

Field Sample Identification	TS-170206-1101	WS-170206-1102	TS-230206-0930	TS-230206-0930 DRIED	RS-270206-1400	TS-270206-1350
Sediment Source	Arthur Kill	Arthur Kill	Arthur Kill	Arthur Kill	Lower Passaic River	Lower Passaic River
Location Identification	TS	WS	TS	TS	RS	TS
Date Collected	2/17/06	2/17/06	2/23/06	2/23/06	2/27/06	2/27/06
Matrix	Solid	Solid	Solid	Solid	Solid	Solid
Analyte/Methods (Units)						
Semi-Volatile Organic Compounds/SW8270C (µg/kg) (continued)						
4,6-Dinitro-2-methylphenol	-	-	-	-	-	-
4-Bromophenyl phenyl ether	-	-	-	-	-	-
4-Chloro-3-methylphenol	-	-	-	-	-	-
4-Chloroaniline	-	-	-	-	-	-
4-Chlorophenyl phenyl ether	-	-	-	-	-	-
4-Methylphenol (p-Cresol)	-	-	-	-	-	-
4-Nitroaniline	-	-	-	-	-	-
4-Nitrophenol	-	-	-	-	-	-
Acenaphthene	270 TDJ	210 TD	180 TD	240 TD	240 TD	200 TD
Acenaphthylene	370 TDJ	120 TD	260 TD	260 TD	550 TD	420 TD
Acetophenone	-	-	-	-	-	-
Aniline	-	-	-	-	-	-
Anthracene	580 TDJ	420 TD	520 TD	500 TD	560 TD	510 TD
Atrazine	-	-	-	-	-	-
Benzaldehyde	-	-	-	-	-	-
Benzidine	-	-	-	-	-	-
Benzo(a)anthracene	1100 DJ	490 TD	940 TDJ	1100 TDJ	1500 TD	1100 TDJ
Benzo(a)pyrene	1000 TDJ	370 TD	850 TDJ	880 TDJ	1200 TD	900 TDJ
Benzo(b)fluoranthene	940 TDJ	400 TD	740 TD	770 TD	1000 TD	760 TDJ
Benzo(g,h,i)perylene	650 TDJ	270 TD	720 TDJ	730 TDJ	780 TD	760 TDJ
Benzo(k)fluoranthene	340 TDJ	150 TD	300 TD	290 TD	490 TD	370 TDJ
Benzoic acid	-	-	-	-	-	-
Benzyl alcohol	-	-	-	-	-	-
Benzyl butyl phthalate	-	-	-	-	-	-
Biphenyl (Diphenyl)	-	-	-	-	-	-

TABLE 2

SEMI-VOLATILE ORGANIC COMPOUNDS SOLID SAMPLE DATA SUMMARY
DEMONSTRATION TESTING AND FULL-SCALE OPERATION OF THE BIOGENESIS SEDIMENT DECONTAMINATION PROCESS
KEASBEY, NEW JERSEY
 (Page 55 of 108)

Field Sample Identification	TS-170206-1101	WS-170206-1102	TS-230206-0930	TS-230206-0930 DRIED	RS-270206-1400	TS-270206-1350
Sediment Source	Arthur Kill	Arthur Kill	Arthur Kill	Arthur Kill	Lower Passaic River	Lower Passaic River
Location Identification	TS	WS	TS	TS	RS	TS
Date Collected	2/17/06	2/17/06	2/23/06	2/23/06	2/27/06	2/27/06
Matrix	Solid	Solid	Solid	Solid	Solid	Solid
Analyte/Methods (Units)						
Semi-Volatile Organic Compounds/SW8270C (µg/kg) (continued)						
bis(2-chloroethoxy) Methane	-	-	-	-	-	-
bis(2-chloroethyl) Ether	-	-	-	-	-	-
bis(2-chloroisopropyl) Ether	-	-	-	-	-	-
bis(2-ethylhexyl) Phthalate	-	-	-	-	-	-
Caprolactam	-	-	-	-	-	-
Carbazole	-	-	-	-	-	-
Chrysene	1200 DJ	440 TD	1100 TDJ	1200 TDJ	1800 TD	1300 D
Cresols, m	<1100 DJ	<2700 D	<2300 D	<2400 D	<2700 D	<1200 D
Cresols, Total	-	-	-	-	-	-
Di-n-butyl phthalate	-	-	-	-	-	-
Di-n-octylphthalate	-	-	-	-	-	-
Dibenz(a,h)anthracene	<19 DJ	<45 D	<39 D	<39 D	<44 D	<20 DUJ
Dibenzofuran	-	-	-	-	-	-
Diethyl Phthalate	-	-	-	-	-	-
Dimethyl phthalate	-	-	-	-	-	-
Fluoranthene	1900 DJ	1100 TD	1700 TDJ	1700 TDJ	3000 DJ	2400 DJ
Fluorene	280 TDJ	140 TD	220 TD	290 TD	230 TD	320 TD
Hexachlorobenzene	<1100 DJ	<55 D	<48 D	<49 D	<55 D	<1200 D
Hexachlorobutadiene	<1100 DJ	<2700 D	<2300 D	<2400 D	<2700 D	<1200 D
Hexachlorocyclopentadiene	-	-	-	-	-	-
Hexachloroethane	<1100 DJ	<2700 D	<2300 D	<2400 D	<2700 D	<1200 DUJ
Indeno(1,2,3-c,d)Pyrene	560 TDJ	150 TD	490 TD	560 TD	670 TD	600 TDJ
Isophorone	-	-	-	-	-	-
n-Nitroso-di-n-propylamine	-	-	-	-	-	-
n-Nitrosodimethylamine	-	-	-	-	-	-

TABLE 2
SEMI-VOLATILE ORGANIC COMPOUNDS SOLID SAMPLE DATA SUMMARY
DEMONSTRATION TESTING AND FULL-SCALE OPERATION OF THE BIOGENESIS SEDIMENT DECONTAMINATION PROCESS
KEASBEY, NEW JERSEY
 (Page 56 of 108)

Field Sample Identification	TS-170206-1101	WS-170206-1102	TS-230206-0930	TS-230206-0930 DRIED	RS-270206-1400	TS-270206-1350
Sediment Source	Arthur Kill	Arthur Kill	Arthur Kill	Arthur Kill	Lower Passaic River	Lower Passaic River
Location Identification	TS	WS	TS	TS	RS	TS
Date Collected	2/17/06	2/17/06	2/23/06	2/23/06	2/27/06	2/27/06
Matrix	Solid	Solid	Solid	Solid	Solid	Solid
Analyte/Methods (Units)						
Semi-Volatile Organic Compounds/SW8270C (µg/kg) (continued)						
n-Nitrosodiphenylamine	-	-	-	-	-	-
Naphthalene	550 TDJ	310 TD	410 TD	410 TD	280 TD	370 TD
Nitrobenzene	<1100 DJ	<2700 D	<2300 D	<2400 D	<2700 D	<1200 D
Pentachlorophenol	<5600 DJ	<13000 D	<11000 DUJ	<12000 DUJ	<13000 D	<6000 D
Phenanthrene	-	-	-	-	-	-
Phenol	-	-	-	-	-	-
Pyrene	2700 DJ	1500 TD	1700 TDJ	1800 TDJ	2800 D	3500 D
Pyridine	-	-	-	-	-	-

µg/kg micrograms per kilogram.
Italic Italicized result indicates analyte reported to the method detection limit.
Bold Bolded result indicates positively identified compound.
 - Not analyzed.
 B Analyte detected in an associated blank.
 D Sample dilution required for analysis; reported values reflect the dilution.
 H Sample holding time was exceeded, but the associated data are considered valid as reported.
 J Data are estimated due to associated quality control data.
 R Associated quality control did not meet acceptance criteria.
 T Analyte was positively identified but the reported concentration is estimated; reported concentration is less than the reporting limit, but greater than the method detection limit.
 UJ Potential low bias, possible false negative.

TABLE 2

SEMI-VOLATILE ORGANIC COMPOUNDS SOLID SAMPLE DATA SUMMARY
DEMONSTRATION TESTING AND FULL-SCALE OPERATION OF THE BIOGENESIS SEDIMENT DECONTAMINATION PROCESS
KEASBEY, NEW JERSEY
 (Page 57 of 108)

Field Sample Identification	TS-270206-1350 DRIED	TS-270206-1630	TS-270206-1630 DRIED	RS-280206-1700	TS-280206-1705	WS-280206-1710
Sediment Source	Lower Passaic River	Lower Passaic River	Lower Passaic River	Arthur Kill	Arthur Kill	Arthur Kill
Location Identification	TS	TS	TS	RS	TS	WS
Date Collected	2/27/06	2/27/06	2/27/06	2/28/06	2/28/06	2/28/06
Matrix	Solid	Solid	Solid	Solid	Solid	Solid
Analyte/Methods (Units)						
Semi-Volatile Organic Compounds/SW8270C (µg/kg)						
1,2,4-Trichlorobenzene	-	-	-	-	-	-
1,2-Dichlorobenzene	-	-	-	-	-	-
1,2-Diphenylhydrazine	-	-	-	-	-	-
1,3-Dichlorobenzene	-	-	-	-	-	-
1,4-Dichlorobenzene	98 TD	100 TD	80 TD	150 TD	170 TD	<3300 D
1,4-Dioxane (p-Dioxane)	-	-	-	-	-	-
2,3,4,6-Tetrachlorophenol	-	-	-	-	-	-
2,3,5,6-Tetrachlorophenol	-	-	-	-	-	-
2,4,5-Trichlorophenol	<1200 D	<1200 D	<1100 D	<2700 D	<1200 D	<3300 D
2,4,6-Trichlorophenol	<1200 D	<1200 D	<1100 D	<2700 D	<1200 D	<3300 D
2,4-Dichlorophenol	-	-	-	-	-	-
2,4-Dimethyl phenol	-	-	-	-	-	-
2,4-Dinitrophenol	-	-	-	-	-	-
2,4-Dinitrotoluene	<1200 D	<1200 D	<1100 D	<2700 D	<1200 D	<3300 D
2,6-Dichlorophenol	-	-	-	-	-	-
2,6-Dinitrotoluene	-	-	-	-	-	-
2-Aminonaphthalene	-	-	-	-	-	-
2-Chloronaphthalene	-	-	-	-	-	-
2-Chlorophenol	-	-	-	-	-	-
2-Methylnaphthalene	-	-	-	-	-	-
2-Methylphenol (o-Cresol)	<1200 DUJ	<1200 DUJ	<1100 DUJ	<2700 D	<1200 D	<3300 D
2-Nitroaniline	-	-	-	-	-	-
2-Nitrophenol	-	-	-	-	-	-
3,3'-Dichlorobenzidine	-	-	-	-	-	-
3-Nitroaniline	-	-	-	-	-	-

TABLE 2

SEMI-VOLATILE ORGANIC COMPOUNDS SOLID SAMPLE DATA SUMMARY
DEMONSTRATION TESTING AND FULL-SCALE OPERATION OF THE BIOGENESIS SEDIMENT DECONTAMINATION PROCESS
KEASBEY, NEW JERSEY
 (Page 58 of 108)

Field Sample Identification	TS-270206-1350 DRIED	TS-270206-1630	TS-270206-1630 DRIED	RS-280206-1700	TS-280206-1705	WS-280206-1710
Sediment Source	Lower Passaic River	Lower Passaic River	Lower Passaic River	Arthur Kill	Arthur Kill	Arthur Kill
Location Identification	TS	TS	TS	RS	TS	WS
Date Collected	2/27/06	2/27/06	2/27/06	2/28/06	2/28/06	2/28/06
Matrix	Solid	Solid	Solid	Solid	Solid	Solid
Analyte/Methods (Units)						
Semi-Volatile Organic Compounds/SW8270C (µg/kg) (continued)						
4,6-Dinitro-2-methylphenol	-	-	-	-	-	-
4-Bromophenyl phenyl ether	-	-	-	-	-	-
4-Chloro-3-methylphenol	-	-	-	-	-	-
4-Chloroaniline	-	-	-	-	-	-
4-Chlorophenyl phenyl ether	-	-	-	-	-	-
4-Methylphenol (p-Cresol)	-	-	-	-	-	-
4-Nitroaniline	-	-	-	-	-	-
4-Nitrophenol	-	-	-	-	-	-
Acenaphthene	230 TD	190 TD	220 TD	330 TD	230 TD	290 TD
Acenaphthylene	460 TD	320 TD	280 TD	450 TD	360 TD	240 TD
Acetophenone	-	-	-	-	-	-
Aniline	-	-	-	-	-	-
Anthracene	570 TD	460 TD	460 TD	610 TD	490 TD	450 TD
Atrazine	-	-	-	-	-	-
Benzaldehyde	-	-	-	-	-	-
Benzidine	-	-	-	-	-	-
Benzo(a)anthracene	1300 DJ	1200 DJ	1200 DJ	1200 TD	1000 TD	530 TD
Benzo(a)pyrene	990 TDJ	920 TDJ	910 TDJ	830 TD	810 TD	320 TD
Benzo(b)fluoranthene	850 TDJ	790 TDJ	780 TDJ	680 TD	700 TD	350 TD
Benzo(g,h,i)perylene	710 TDJ	660 TDJ	590 TDJ	490 TD	480 TD	280 TD
Benzo(k)fluoranthene	390 TDJ	360 TDJ	330 TDJ	270 TD	270 TD	120 TD
Benzoic acid	-	-	-	-	-	-
Benzyl alcohol	-	-	-	-	-	-
Benzyl butyl phthalate	-	-	-	-	-	-
Biphenyl (Diphenyl)	-	-	-	-	-	-

TABLE 2

SEMI-VOLATILE ORGANIC COMPOUNDS SOLID SAMPLE DATA SUMMARY
DEMONSTRATION TESTING AND FULL-SCALE OPERATION OF THE BIOGENESIS SEDIMENT DECONTAMINATION PROCESS
KEASBEY, NEW JERSEY
 (Page 59 of 108)

Field Sample Identification	TS-270206-1350 DRIED	TS-270206-1630	TS-270206-1630 DRIED	RS-280206-1700	TS-280206-1705	WS-280206-1710
Sediment Source	Lower Passaic River	Lower Passaic River	Lower Passaic River	Arthur Kill	Arthur Kill	Arthur Kill
Location Identification	TS	TS	TS	RS	TS	WS
Date Collected	2/27/06	2/27/06	2/27/06	2/28/06	2/28/06	2/28/06
Matrix	Solid	Solid	Solid	Solid	Solid	Solid
Analyte/Methods (Units)						
Semi-Volatile Organic Compounds/SW8270C (µg/kg) (continued)						
bis(2-chloroethoxy) Methane	-	-	-	-	-	-
bis(2-chloroethyl) Ether	-	-	-	-	-	-
bis(2-chloroisopropyl) Ether	-	-	-	-	-	-
bis(2-ethylhexyl) Phthalate	-	-	-	-	-	-
Caprolactam	-	-	-	-	-	-
Carbazole	-	-	-	-	-	-
Chrysene	1500 D	1400 D	1300 D	1200 TD	1300 D	680 TD
Cresols, m	<1200 D	<1200 D	<1100 D	<2700 D	<1200 D	<3300 D
Cresols, Total	-	-	-	-	-	-
Di-n-butyl phthalate	-	-	-	-	-	-
Di-n-octylphthalate	-	-	-	-	-	-
Dibenz(a,h)anthracene	<19 DUJ	150 TDJ	150 TDJ	<45 D	<20 D	<54 D
Dibenzofuran	-	-	-	-	-	-
Diethyl Phthalate	-	-	-	-	-	-
Dimethyl phthalate	-	-	-	-	-	-
Fluoranthene	2700 DJ	2400 DJ	2300 DJ	2100 TDJ	2000 DJ	1300 TDJ
Fluorene	280 TD	230 TD	200 TD	270 TD	260 TD	240 TD
Hexachlorobenzene	<1200 D	<1200 D	<1100 D	<55 D	<1200 D	<66 D
Hexachlorobutadiene	<1200 D	<1200 D	<1100 D	<2700 D	<1200 D	<3300 D
Hexachlorocyclopentadiene	-	-	-	-	-	-
Hexachloroethane	<1200 DUJ	<1200 DUJ	<1100 DUJ	<2700 D	<1200 D	<3300 D
Indeno(1,2,3-c,d)Pyrene	630 TDJ	600 TDJ	560 TDJ	480 TD	440 TD	180 TD
Isophorone	-	-	-	-	-	-
n-Nitroso-di-n-propylamine	-	-	-	-	-	-
n-Nitrosodimethylamine	-	-	-	-	-	-

TABLE 2

SEMI-VOLATILE ORGANIC COMPOUNDS SOLID SAMPLE DATA SUMMARY
DEMONSTRATION TESTING AND FULL-SCALE OPERATION OF THE BIOGENESIS SEDIMENT DECONTAMINATION PROCESS
KEASBEY, NEW JERSEY
 (Page 60 of 108)

Field Sample Identification	TS-270206-1350 DRIED	TS-270206-1630	TS-270206-1630 DRIED	RS-280206-1700	TS-280206-1705	WS-280206-1710
Sediment Source	Lower Passaic River	Lower Passaic River	Lower Passaic River	Arthur Kill	Arthur Kill	Arthur Kill
Location Identification	TS	TS	TS	RS	TS	WS
Date Collected	2/27/06	2/27/06	2/27/06	2/28/06	2/28/06	2/28/06
Matrix	Solid	Solid	Solid	Solid	Solid	Solid
Analyte/Methods (Units)						
Semi-Volatile Organic Compounds/SW8270C (µg/kg) (continued)						
n-Nitrosodiphenylamine	-	-	-	-	-	-
Naphthalene	350 TD	220 TD	210 TD	540 TD	520 TD	440 TD
Nitrobenzene	<1200 D	<1200 D	<1100 D	<2700 D	<1200 D	<3300 D
Pentachlorophenol	<5700 D	<5700 D	<5500 D	<13000 D	<6000 D	<16000 D
Phenanthrene	-	-	-	-	-	-
Phenol	-	-	-	-	-	-
Pyrene	2800 D	2300 D	2200 D	2200 TD	2000 D	1300 TD
Pyridine	-	-	-	-	-	-

µg/kg micrograms per kilogram.

Italic Italicized result indicates analyte reported to the method detection limit.

Bold Bolded result indicates positively identified compound.

- Not analyzed.

B Analyte detected in an associated blank.

D Sample dilution required for analysis; reported values reflect the dilution.

H Sample holding time was exceeded, but the associated data are considered valid as reported.

J Data are estimated due to associated quality control data.

R Associated quality control did not meet acceptance criteria.

T Analyte was positively identified but the reported concentration is estimated; reported concentration is less than the reporting limit, but greater than the method detection limit.

UJ Potential low bias, possible false negative.

TABLE 2

SEMI-VOLATILE ORGANIC COMPOUNDS SOLID SAMPLE DATA SUMMARY
DEMONSTRATION TESTING AND FULL-SCALE OPERATION OF THE BIOGENESIS SEDIMENT DECONTAMINATION PROCESS
KEASBEY, NEW JERSEY
 (Page 61 of 108)

Field Sample Identification	RS-010306-1700	TS-010306-1705	WS-010306-1710	SS-020306-1400	RS-020306-1700	TS-020306-1705
Sediment Source	Arthur Kill	Arthur Kill	Arthur Kill	Arthur Kill	Arthur Kill	Arthur Kill
Location Identification	RS	TS	WS	SS1	RS	TS
Date Collected	3/1/06	3/1/06	3/1/06	3/2/06	3/2/06	3/2/06
Matrix	Solid	Solid	Solid	Solid	Solid	Solid
Analyte/Methods (Units)						
Semi-Volatile Organic Compounds/SW8270C (µg/kg)						
1,2,4-Trichlorobenzene	-	-	-	-	-	-
1,2-Dichlorobenzene	-	-	-	-	-	-
1,2-Diphenylhydrazine	-	-	-	-	-	-
1,3-Dichlorobenzene	-	-	-	-	-	-
1,4-Dichlorobenzene	480 TD	180 TD	<12000 D	<14000 D	150 TD	120 TD
1,4-Dioxane (p-Dioxane)	-	-	-	-	-	-
2,3,4,6-Tetrachlorophenol	-	-	-	-	-	-
2,3,5,6-Tetrachlorophenol	-	-	-	-	-	-
2,4,5-Trichlorophenol	<13000 D	<5200 D	<12000 D	<14000 D	<6900 D	<2800 D
2,4,6-Trichlorophenol	<13000 D	<5200 D	<12000 D	<14000 D	<6900 D	<2800 D
2,4-Dichlorophenol	-	-	-	-	-	-
2,4-Dimethyl phenol	-	-	-	-	-	-
2,4-Dinitrophenol	-	-	-	-	-	-
2,4-Dinitrotoluene	730 TD	<55 D	<130 D	<150 D	<73 D	<2800 D
2,6-Dichlorophenol	-	-	-	-	-	-
2,6-Dinitrotoluene	-	-	-	-	-	-
2-Aminonaphthalene	-	-	-	-	-	-
2-Chloronaphthalene	-	-	-	-	-	-
2-Chlorophenol	-	-	-	-	-	-
2-Methylnaphthalene	-	-	-	-	-	-
2-Methylphenol (o-Cresol)	440 TD	<5200 D	<12000 D	<14000 D	<6900 D	<2800 D
2-Nitroaniline	-	-	-	-	-	-
2-Nitrophenol	-	-	-	-	-	-
3,3'-Dichlorobenzidine	-	-	-	-	-	-
3-Nitroaniline	-	-	-	-	-	-

TABLE 2

SEMI-VOLATILE ORGANIC COMPOUNDS SOLID SAMPLE DATA SUMMARY
DEMONSTRATION TESTING AND FULL-SCALE OPERATION OF THE BIOGENESIS SEDIMENT DECONTAMINATION PROCESS
KEASBEY, NEW JERSEY
 (Page 62 of 108)

Field Sample Identification	RS-010306-1700	TS-010306-1705	WS-010306-1710	SS-020306-1400	RS-020306-1700	TS-020306-1705
Sediment Source	Arthur Kill	Arthur Kill	Arthur Kill	Arthur Kill	Arthur Kill	Arthur Kill
Location Identification	RS	TS	WS	SS1	RS	TS
Date Collected	3/1/06	3/1/06	3/1/06	3/2/06	3/2/06	3/2/06
Matrix	Solid	Solid	Solid	Solid	Solid	Solid
Analyte/Methods (Units)						
Semi-Volatile Organic Compounds/SW8270C (µg/kg) (continued)						
4,6-Dinitro-2-methylphenol	-	-	-	-	-	-
4-Bromophenyl phenyl ether	-	-	-	-	-	-
4-Chloro-3-methylphenol	-	-	-	-	-	-
4-Chloroaniline	-	-	-	-	-	-
4-Chlorophenyl phenyl ether	-	-	-	-	-	-
4-Methylphenol (p-Cresol)	-	-	-	-	-	-
4-Nitroaniline	-	-	-	-	-	-
4-Nitrophenol	-	-	-	-	-	-
Acenaphthene	840 TD	340 TD	350 TD	2700 TD	370 TD	150 TD
Acenaphthylene	1100 TD	470 TD	310 TD	2300 TD	380 TD	200 TD
Acetophenone	-	-	-	-	-	-
Aniline	-	-	-	-	-	-
Anthracene	1400 TD	510 TD	<12000 D	5700 TD	910 TD	460 TD
Atrazine	-	-	-	-	-	-
Benzaldehyde	-	-	-	-	-	-
Benzydine	-	-	-	-	-	-
Benzo(a)anthracene	2400 TD	1200 TD	<270 D	8100 TD	1200 TD	660 TD
Benzo(a)pyrene	1500 TD	780 TD	<210 D	2300 TD	1100 TD	590 TD
Benzo(b)fluoranthene	1100 TD	670 TDJ	<250 D	2000 TD	1100 TD	640 TD
Benzo(g,h,i)perylene	1200 TD	530 TD	<12000 D	850 TD	490 TD	310 TD
Benzo(k)fluoranthene	910 TD	260 TDJ	<240 D	<270 D	390 TD	210 TD
Benzoic acid	-	-	-	-	-	-
Benzyl alcohol	-	-	-	-	-	-
Benzyl butyl phthalate	-	-	-	-	-	-
Biphenyl (Diphenyl)	-	-	-	-	-	-

TABLE 2

SEMI-VOLATILE ORGANIC COMPOUNDS SOLID SAMPLE DATA SUMMARY
DEMONSTRATION TESTING AND FULL-SCALE OPERATION OF THE BIOGENESIS SEDIMENT DECONTAMINATION PROCESS
KEASBEY, NEW JERSEY
 (Page 63 of 108)

Field Sample Identification	RS-010306-1700	TS-010306-1705	WS-010306-1710	SS-020306-1400	RS-020306-1700	TS-020306-1705
Sediment Source	Arthur Kill	Arthur Kill	Arthur Kill	Arthur Kill	Arthur Kill	Arthur Kill
Location Identification	RS	TS	WS	SS1	RS	TS
Date Collected	3/1/06	3/1/06	3/1/06	3/2/06	3/2/06	3/2/06
Matrix	Solid	Solid	Solid	Solid	Solid	Solid
Analyte/Methods (Units)						
Semi-Volatile Organic Compounds/SW8270C (µg/kg) (continued)						
bis(2-chloroethoxy) Methane	-	-	-	-	-	-
bis(2-chloroethyl) Ether	-	-	-	-	-	-
bis(2-chloroisopropyl) Ether	-	-	-	-	-	-
bis(2-ethylhexyl) Phthalate	-	-	-	-	-	-
Caprolactam	-	-	-	-	-	-
Carbazole	-	-	-	-	-	-
Chrysene	2200 TD	1300 TD	<12000 D	9000 TD	1500 TD	800 TD
Cresols, m	<13000 D	<5200 D	<12000 D	<14000 D	<6900 D	<2800 D
Cresols, Total	-	-	-	-	-	-
Di-n-butyl phthalate	-	-	-	-	-	-
Di-n-octylphthalate	-	-	-	-	-	-
Dibenz(a,h)anthracene	<210 D	<86 D	<200 D	<230 D	<110 D	80 TD
Dibenzofuran	-	-	-	-	-	-
Diethyl Phthalate	-	-	-	-	-	-
Dimethyl phthalate	-	-	-	-	-	-
Fluoranthene	3100 TD	1800 TDJ	<12000 D	19000 D	3000 TD	1500 TD
Fluorene	850 TD	380 TD	<12000 D	3800 TD	450 TD	180 TD
Hexachlorobenzene	<260 D	<110 D	<250 D	<280 D	<140 D	<57 D
Hexachlorobutadiene	<13000 D	<5200 D	<12000 D	<14000 D	<6900 D	<2800 D
Hexachlorocyclopentadiene	-	-	-	-	-	-
Hexachloroethane	<13000 D	<5200 DUJ	<12000 D	<14000 D	<6900 D	<2800 D
Indeno(1,2,3-c,d)Pyrene	1200 TD	520 TD	<250 D	710 TD	410 TD	240 TD
Isophorone	-	-	-	-	-	-
n-Nitroso-di-n-propylamine	-	-	-	-	-	-
n-Nitrosodimethylamine	-	-	-	-	-	-

TABLE 2

SEMI-VOLATILE ORGANIC COMPOUNDS SOLID SAMPLE DATA SUMMARY
DEMONSTRATION TESTING AND FULL-SCALE OPERATION OF THE BIOGENESIS SEDIMENT DECONTAMINATION PROCESS
KEASBEY, NEW JERSEY
 (Page 64 of 108)

Field Sample Identification	RS-010306-1700	TS-010306-1705	WS-010306-1710	SS-020306-1400	RS-020306-1700	TS-020306-1705
Sediment Source	Arthur Kill	Arthur Kill	Arthur Kill	Arthur Kill	Arthur Kill	Arthur Kill
Location Identification	RS	TS	WS	SS1	RS	TS
Date Collected	3/1/06	3/1/06	3/1/06	3/2/06	3/2/06	3/2/06
Matrix	Solid	Solid	Solid	Solid	Solid	Solid
Analyte/Methods (Units)						
Semi-Volatile Organic Compounds/SW8270C (µg/kg) (continued)						
n-Nitrosodiphenylamine	-	-	-	-	-	-
Naphthalene	1000 TD	580 TD	<12000 D	4100 TD	510 TD	320 TD
Nitrobenzene	<13000 D	<5200 D	<12000 D	<14000 D	<6900 D	<2800 D
Pentachlorophenol	<18000 D	<7200 DUJ	<17000 D	<19000 D	<9600 D	<13000 D
Phenanthrene	-	-	-	-	-	-
Phenol	-	-	-	-	-	-
Pyrene	4200 TD	2500 TD	1500 TD	12000 TD	1800 TD	910 TD
Pyridine	-	-	-	-	-	-

µg/kg micrograms per kilogram.

Italic Italicized result indicates analyte reported to the method detection limit.

Bold Bolded result indicates positively identified compound.

- Not analyzed.

B Analyte detected in an associated blank.

D Sample dilution required for analysis; reported values reflect the dilution.

H Sample holding time was exceeded, but the associated data are considered valid as reported.

J Data are estimated due to associated quality control data.

R Associated quality control did not meet acceptance criteria.

T Analyte was positively identified but the reported concentration is estimated; reported concentration is less than the reporting limit, but greater than the method detection limit.

UJ Potential low bias, possible false negative.

TABLE 2

SEMI-VOLATILE ORGANIC COMPOUNDS SOLID SAMPLE DATA SUMMARY
DEMONSTRATION TESTING AND FULL-SCALE OPERATION OF THE BIOGENESIS SEDIMENT DECONTAMINATION PROCESS
KEASBEY, NEW JERSEY
 (Page 65 of 108)

Field Sample Identification	WS-020306-1710	RS-030306-1200	TS-030306-1205	WS-030306-1210	PSS-060406-1200	RS-060406-1215
Sediment Source	Arthur Kill	Arthur Kill	Arthur Kill	Arthur Kill	Arthur Kill	Arthur Kill
Location Identification	WS	RS	TS	WS	PSS	RS
Date Collected	3/2/06	3/3/06	3/3/06	3/3/06	4/6/06	4/6/06
Matrix	Solid	Solid	Solid	Solid	Solid	Solid
Analyte/Methods (Units)						
Semi-Volatile Organic Compounds/SW8270C (µg/kg)						
1,2,4-Trichlorobenzene	-	-	-	-	-	-
1,2-Dichlorobenzene	-	-	-	-	-	-
1,2-Diphenylhydrazine	-	-	-	-	-	-
1,3-Dichlorobenzene	-	-	-	-	-	-
1,4-Dichlorobenzene	67 TD	110 TD	100 TD	<2900 D	<23000 D	<5700 D
1,4-Dioxane (p-Dioxane)	-	-	-	-	-	-
2,3,4,6-Tetrachlorophenol	-	-	-	-	-	-
2,3,5,6-Tetrachlorophenol	-	-	-	-	-	-
2,4,5-Trichlorophenol	<3100 D	<3900 D	<2800 D	<2900 D	<23000 D	<5700 D
2,4,6-Trichlorophenol	<3100 D	<3900 D	<2800 D	<2900 D	<23000 D	<5700 D
2,4-Dichlorophenol	-	-	-	-	-	-
2,4-Dimethyl phenol	-	-	-	-	-	-
2,4-Dinitrophenol	-	-	-	-	-	-
2,4-Dinitrotoluene	<3100 D	<3900 D	<2800 D	<2900 D	<250 D	<60 D
2,6-Dichlorophenol	-	-	-	-	-	-
2,6-Dinitrotoluene	-	-	-	-	-	-
2-Aminonaphthalene	-	-	-	-	-	-
2-Chloronaphthalene	-	-	-	-	-	-
2-Chlorophenol	-	-	-	-	-	-
2-Methylnaphthalene	-	-	-	-	-	-
2-Methylphenol (o-Cresol)	<3100 D	<3900 D	<2800 D	<2900 D	3100 TDB	2000 TDB
2-Nitroaniline	-	-	-	-	-	-
2-Nitrophenol	-	-	-	-	-	-
3,3'-Dichlorobenzidine	-	-	-	-	-	-
3-Nitroaniline	-	-	-	-	-	-

TABLE 2

SEMI-VOLATILE ORGANIC COMPOUNDS SOLID SAMPLE DATA SUMMARY
DEMONSTRATION TESTING AND FULL-SCALE OPERATION OF THE BIOGENESIS SEDIMENT DECONTAMINATION PROCESS
KEASBEY, NEW JERSEY
 (Page 66 of 108)

Field Sample Identification	WS-020306-1710	RS-030306-1200	TS-030306-1205	WS-030306-1210	PSS-060406-1200	RS-060406-1215
Sediment Source	Arthur Kill	Arthur Kill	Arthur Kill	Arthur Kill	Arthur Kill	Arthur Kill
Location Identification	WS	RS	TS	WS	PSS	RS
Date Collected	3/2/06	3/3/06	3/3/06	3/3/06	4/6/06	4/6/06
Matrix	Solid	Solid	Solid	Solid	Solid	Solid
Analyte/Methods (Units)						
Semi-Volatile Organic Compounds/SW8270C (µg/kg) (continued)						
4,6-Dinitro-2-methylphenol	-	-	-	-	-	-
4-Bromophenyl phenyl ether	-	-	-	-	-	-
4-Chloro-3-methylphenol	-	-	-	-	-	-
4-Chloroaniline	-	-	-	-	-	-
4-Chlorophenyl phenyl ether	-	-	-	-	-	-
4-Methylphenol (p-Cresol)	-	-	-	-	-	-
4-Nitroaniline	-	-	-	-	-	-
4-Nitrophenol	-	-	-	-	-	-
Acenaphthene	210 TD	230 TD	220 TD	72 TD	<23000 D	380 TD
Acenaphthylene	190 TD	270 TD	340 TD	<2900 D	620 TD	770 TD
Acetophenone	-	-	-	-	-	-
Aniline	-	-	-	-	-	-
Anthracene	490 TD	610 TD	590 TD	260 TD	780 TD	760 TD
Atrazine	-	-	-	-	-	-
Benzaldehyde	-	-	-	-	-	-
Benzydine	-	-	-	-	-	-
Benzo(a)anthracene	540 TD	910 TD	910 TD	260 TD	1200 TD	1300 TD
Benzo(a)pyrene	380 TD	750 TD	820 TD	220 TD	930 TD	1100 TD
Benzo(b)fluoranthene	440 TD	710 TD	810 TD	210 TD	810 TD	1100 TD
Benzo(g,h,i)perylene	170 TDJ	340 TD	390 TDJ	<2900 D	590 TD	660 TD
Benzo(k)fluoranthene	180 TD	320 TD	330 TD	<2900 D	<460 D	500 TD
Benzoic acid	-	-	-	-	-	-
Benzyl alcohol	-	-	-	-	-	-
Benzyl butyl phthalate	-	-	-	-	-	-
Biphenyl (Diphenyl)	-	-	-	-	-	-

TABLE 2

SEMI-VOLATILE ORGANIC COMPOUNDS SOLID SAMPLE DATA SUMMARY
DEMONSTRATION TESTING AND FULL-SCALE OPERATION OF THE BIOGENESIS SEDIMENT DECONTAMINATION PROCESS
KEASBEY, NEW JERSEY
 (Page 67 of 108)

Field Sample Identification	WS-020306-1710	RS-030306-1200	TS-030306-1205	WS-030306-1210	PSS-060406-1200	RS-060406-1215
Sediment Source	Arthur Kill	Arthur Kill	Arthur Kill	Arthur Kill	Arthur Kill	Arthur Kill
Location Identification	WS	RS	TS	WS	PSS	RS
Date Collected	3/2/06	3/3/06	3/3/06	3/3/06	4/6/06	4/6/06
Matrix	Solid	Solid	Solid	Solid	Solid	Solid
Analyte/Methods (Units)						
Semi-Volatile Organic Compounds/SW8270C (µg/kg) (continued)						
bis(2-chloroethoxy) Methane	-	-	-	-	-	-
bis(2-chloroethyl) Ether	-	-	-	-	-	-
bis(2-chloroisopropyl) Ether	-	-	-	-	-	-
bis(2-ethylhexyl) Phthalate	-	-	-	-	-	-
Caprolactam	-	-	-	-	-	-
Carbazole	-	-	-	-	-	-
Chrysene	680 TD	1000 TD	1100 TD	330 TD	1200 TD	1500 TD
Cresols, m	<3100 D	<3900 D	<2800 D	<2900 D	5100 TD	3200 TD
Cresols, Total	-	-	-	-	-	-
Di-n-butyl phthalate	-	-	-	-	-	-
Di-n-octylphthalate	-	-	-	-	-	-
Dibenz(a,h)anthracene	<52 D	<65 D	<47 D	<48 D	<390 D	<94 D
Dibenzofuran	-	-	-	-	-	-
Diethyl Phthalate	-	-	-	-	-	-
Dimethyl phthalate	-	-	-	-	-	-
Fluoranthene	1600 TD	2200 TD	2200 TD	590 TD	2200 TD	3000 TD
Fluorene	170 TD	210 TD	270 TD	<2900 D	<23000 D	400 TD
Hexachlorobenzene	<64 D	<80 D	<58 D	<60 D	<470 D	<120 D
Hexachlorobutadiene	<3100 D	<3900 D	<2800 D	<2900 D	<460 D	<5700 D
Hexachlorocyclopentadiene	-	-	-	-	-	-
Hexachloroethane	<3100 DUJ	<3900 D	<2800 DUJ	<2900 D	<23000 D	<5700 D
Indeno(1,2,3-c,d)Pyrene	120 TDJ	270 TD	310 TDJ	<2900 D	590 TD	570 TD
Isophorone	-	-	-	-	-	-
n-Nitroso-di-n-propylamine	-	-	-	-	-	-
n-Nitrosodimethylamine	-	-	-	-	-	-

TABLE 2

SEMI-VOLATILE ORGANIC COMPOUNDS SOLID SAMPLE DATA SUMMARY
DEMONSTRATION TESTING AND FULL-SCALE OPERATION OF THE BIOGENESIS SEDIMENT DECONTAMINATION PROCESS
KEASBEY, NEW JERSEY
 (Page 68 of 108)

Field Sample Identification	WS-020306-1710	RS-030306-1200	TS-030306-1205	WS-030306-1210	PSS-060406-1200	RS-060406-1215
Sediment Source	Arthur Kill	Arthur Kill	Arthur Kill	Arthur Kill	Arthur Kill	Arthur Kill
Location Identification	WS	RS	TS	WS	PSS	RS
Date Collected	3/2/06	3/3/06	3/3/06	3/3/06	4/6/06	4/6/06
Matrix	Solid	Solid	Solid	Solid	Solid	Solid
Analyte/Methods (Units)						
Semi-Volatile Organic Compounds/SW8270C (µg/kg) (continued)						
n-Nitrosodiphenylamine	-	-	-	-	-	-
Naphthalene	<3100 D	340 TD	420 TD	120 TD	1100 TD	730 TD
Nitrobenzene	<3100 D	<3900 D	<2800 D	<2900 D	<23000 D	<5700 D
Pentachlorophenol	<15000 D	<19000 D	<14000 D	<14000 D	<32000 D	<7900 D
Phenanthrene	-	-	-	-	-	-
Phenol	-	-	-	-	-	-
Pyrene	870 TD	1300 TD	1300 TD	530 TD	1800 TD	2200 TD
Pyridine	-	-	-	-	-	-

µg/kg micrograms per kilogram.

Italic Italicized result indicates analyte reported to the method detection limit.

Bold Bolded result indicates positively identified compound.

- Not analyzed.

B Analyte detected in an associated blank.

D Sample dilution required for analysis; reported values reflect the dilution.

H Sample holding time was exceeded, but the associated data are considered valid as reported.

J Data are estimated due to associated quality control data.

R Associated quality control did not meet acceptance criteria.

T Analyte was positively identified but the reported concentration is estimated; reported concentration is less than the reporting limit, but greater than the method detection limit.

UJ Potential low bias, possible false negative.

TABLE 2

SEMI-VOLATILE ORGANIC COMPOUNDS SOLID SAMPLE DATA SUMMARY
DEMONSTRATION TESTING AND FULL-SCALE OPERATION OF THE BIOGENESIS SEDIMENT DECONTAMINATION PROCESS
KEASBEY, NEW JERSEY
 (Page 69 of 108)

Field Sample Identification	SS1-060406-1205	SS2-060406-1210	TS-060406-1240	WS-060406-1300	PSS-100406-1510	SS1-100406-1515
Sediment Source	Arthur Kill	Arthur Kill	Arthur Kill	Arthur Kill	Arthur Kill	Arthur Kill
Location Identification	SS1	SS2	TS	WS	PSS	SS1
Date Collected	4/6/06	4/6/06	4/6/06	4/6/06	4/10/06	4/10/06
Matrix	Solid	Solid	Solid	Solid	Solid	Solid
Analyte/Methods (Units)						
Semi-Volatile Organic Compounds/SW8270C (µg/kg)						
1,2,4-Trichlorobenzene	-	-	-	-	-	-
1,2-Dichlorobenzene	-	-	-	-	-	-
1,2-Diphenylhydrazine	-	-	-	-	-	-
1,3-Dichlorobenzene	-	-	-	-	-	-
1,4-Dichlorobenzene	<6100 D	180 TD	<5100 D	<12000 D	<5800 D	100 TD
1,4-Dioxane (p-Dioxane)	-	-	-	-	-	-
2,3,4,6-Tetrachlorophenol	-	-	-	-	-	-
2,3,5,6-Tetrachlorophenol	-	-	-	-	-	-
2,4,5-Trichlorophenol	<6100 D	<7700 D	<5100 DUJ	<12000 D	<5800 D	<3100 D
2,4,6-Trichlorophenol	<6100 D	<7700 D	<5100 DUJ	<12000 D	<5800 D	<3100 D
2,4-Dichlorophenol	-	-	-	-	-	-
2,4-Dimethyl phenol	-	-	-	-	-	-
2,4-Dinitrophenol	-	-	-	-	-	-
2,4-Dinitrotoluene	<65 D	<81 D	<54 D	<130 D	<61 D	<3100 D
2,6-Dichlorophenol	-	-	-	-	-	-
2,6-Dinitrotoluene	-	-	-	-	-	-
2-Aminonaphthalene	-	-	-	-	-	-
2-Chloronaphthalene	-	-	-	-	-	-
2-Chlorophenol	-	-	-	-	-	-
2-Methylnaphthalene	-	-	-	-	-	-
2-Methylphenol (o-Cresol)	1700 TDB	1900 TDB	1400 TDB	3500 TDB	<5800 D	<3100 D
2-Nitroaniline	-	-	-	-	-	-
2-Nitrophenol	-	-	-	-	-	-
3,3'-Dichlorobenzidine	-	-	-	-	-	-
3-Nitroaniline	-	-	-	-	-	-

TABLE 2

SEMI-VOLATILE ORGANIC COMPOUNDS SOLID SAMPLE DATA SUMMARY
DEMONSTRATION TESTING AND FULL-SCALE OPERATION OF THE BIOGENESIS SEDIMENT DECONTAMINATION PROCESS
KEASBEY, NEW JERSEY
 (Page 70 of 108)

Field Sample Identification	SS1-060406-1205	SS2-060406-1210	TS-060406-1240	WS-060406-1300	PSS-100406-1510	SS1-100406-1515
Sediment Source	Arthur Kill	Arthur Kill	Arthur Kill	Arthur Kill	Arthur Kill	Arthur Kill
Location Identification	SS1	SS2	TS	WS	PSS	SS1
Date Collected	4/6/06	4/6/06	4/6/06	4/6/06	4/10/06	4/10/06
Matrix	Solid	Solid	Solid	Solid	Solid	Solid
Analyte/Methods (Units)						
Semi-Volatile Organic Compounds/SW8270C (µg/kg) (continued)						
4,6-Dinitro-2-methylphenol	-	-	-	-	-	-
4-Bromophenyl phenyl ether	-	-	-	-	-	-
4-Chloro-3-methylphenol	-	-	-	-	-	-
4-Chloroaniline	-	-	-	-	-	-
4-Chlorophenyl phenyl ether	-	-	-	-	-	-
4-Methylphenol (p-Cresol)	-	-	-	-	-	-
4-Nitroaniline	-	-	-	-	-	-
4-Nitrophenol	-	-	-	-	-	-
Acenaphthene	900 TD	980 TD	210 TD	<12000 D	210 TD	240 TD
Acenaphthylene	1500 TD	2000 TD	450 TD	<12000 D	430 TD	390 TD
Acetophenone	-	-	-	-	-	-
Aniline	-	-	-	-	-	-
Anthracene	2100 TD	2300 TD	540 TD	<12000 D	640 TD	720 TD
Atrazine	-	-	-	-	-	-
Benzaldehyde	-	-	-	-	-	-
Benzidine	-	-	-	-	-	-
Benzo(a)anthracene	4300 TD	5200 TD	1000 TD	410 TD	910 TD	970 TD
Benzo(a)pyrene	2800 TD	4100 TD	830 TD	<210 D	720 TD	600 TD
Benzo(b)fluoranthene	2500 TD	3600 TD	800 TDJ	<250 D	690 TD	640 TD
Benzo(g,h,i)perylene	1300 TD	2000 TD	460 TD	<12000 D	430 TD	290 TD
Benzo(k)fluoranthene	1000 TD	1600 TD	360 TDJ	<250 D	290 TD	220 TD
Benzoic acid	-	-	-	-	-	-
Benzyl alcohol	-	-	-	-	-	-
Benzyl butyl phthalate	-	-	-	-	-	-
Biphenyl (Diphenyl)	-	-	-	-	-	-

TABLE 2

SEMI-VOLATILE ORGANIC COMPOUNDS SOLID SAMPLE DATA SUMMARY
DEMONSTRATION TESTING AND FULL-SCALE OPERATION OF THE BIOGENESIS SEDIMENT DECONTAMINATION PROCESS
KEASBEY, NEW JERSEY
 (Page 71 of 108)

Field Sample Identification	SS1-060406-1205	SS2-060406-1210	TS-060406-1240	WS-060406-1300	PSS-100406-1510	SS1-100406-1515
Sediment Source	Arthur Kill	Arthur Kill	Arthur Kill	Arthur Kill	Arthur Kill	Arthur Kill
Location Identification	SS1	SS2	TS	WS	PSS	SS1
Date Collected	4/6/06	4/6/06	4/6/06	4/6/06	4/10/06	4/10/06
Matrix	Solid	Solid	Solid	Solid	Solid	Solid
Analyte/Methods (Units)						
Semi-Volatile Organic Compounds/SW8270C (µg/kg) (continued)						
bis(2-chloroethoxy) Methane	-	-	-	-	-	-
bis(2-chloroethyl) Ether	-	-	-	-	-	-
bis(2-chloroisopropyl) Ether	-	-	-	-	-	-
bis(2-ethylhexyl) Phthalate	-	-	-	-	-	-
Caprolactam	-	-	-	-	-	-
Carbazole	-	-	-	-	-	-
Chrysene	4900 TD	5400 TD	1200 TD	<12000 D	980 TD	1100 TD
Cresols, m	2600 TD	3000 TD	2100 TD	5400 TD	<5800 D	<3100 D
Cresols, Total	-	-	-	-	-	-
Di-n-butyl phthalate	-	-	-	-	-	-
Di-n-octylphthalate	-	-	-	-	-	-
Dibenz(a,h)anthracene	<100 D	520 TD	<84 DUJ	<210 D	<95 D	<52 D
Dibenzofuran	-	-	-	-	-	-
Diethyl Phthalate	-	-	-	-	-	-
Dimethyl phthalate	-	-	-	-	-	-
Fluoranthene	11000 D	11000 D	2400 TDJ	960 TD	2100 TD	2100 TD
Fluorene	1300 TD	1200 TD	200 TDJ	<12000 D	<5800 D	240 TD
Hexachlorobenzene	<120 D	<160 D	<100 DUJ	<250 D	<120 D	<64 D
Hexachlorobutadiene	<6100 D	<7700 D	<5100 D	<12000 D	<5800 D	<3100 D
Hexachlorocyclopentadiene	-	-	-	-	-	-
Hexachloroethane	<6100 D	<7700 D	<5100 DUJ	<12000 D	<5800 D	<3100 D
Indeno(1,2,3-c,d)Pyrene	1200 TD	2000 TD	470 TD	<250 D	350 TD	250 TD
Isophorone	-	-	-	-	-	-
n-Nitroso-di-n-propylamine	-	-	-	-	-	-
n-Nitrosodimethylamine	-	-	-	-	-	-

TABLE 2

SEMI-VOLATILE ORGANIC COMPOUNDS SOLID SAMPLE DATA SUMMARY
DEMONSTRATION TESTING AND FULL-SCALE OPERATION OF THE BIOGENESIS SEDIMENT DECONTAMINATION PROCESS
KEASBEY, NEW JERSEY
 (Page 72 of 108)

Field Sample Identification	SS1-060406-1205	SS2-060406-1210	TS-060406-1240	WS-060406-1300	PSS-100406-1510	SS1-100406-1515
Sediment Source	Arthur Kill	Arthur Kill	Arthur Kill	Arthur Kill	Arthur Kill	Arthur Kill
Location Identification	SS1	SS2	TS	WS	PSS	SS1
Date Collected	4/6/06	4/6/06	4/6/06	4/6/06	4/10/06	4/10/06
Matrix	Solid	Solid	Solid	Solid	Solid	Solid
Analyte/Methods (Units)						
Semi-Volatile Organic Compounds/SW8270C (µg/kg) (continued)						
n-Nitrosodiphenylamine	-	-	-	-	-	-
Naphthalene	1200 TD	1500 TD	500 TD	820 TD	<5800 D	310 TD
Nitrobenzene	<6100 D	<7700 D	<5100 D	<12000 D	<5800 D	<3100 D
Pentachlorophenol	<8500 D	<11000 D	<7100 D	<17000 D	<8000 D	<15000 D
Phenanthrene	-	-	-	-	-	-
Phenol	-	-	-	-	-	-
Pyrene	9100 D	7800 D	1700 TD	840 TD	1600 TD	1600 TD
Pyridine	-	-	-	-	-	-

µg/kg micrograms per kilogram.

Italic Italicized result indicates analyte reported to the method detection limit.

Bold Bolded result indicates positively identified compound.

- Not analyzed.

B Analyte detected in an associated blank.

D Sample dilution required for analysis; reported values reflect the dilution.

H Sample holding time was exceeded, but the associated data are considered valid as reported.

J Data are estimated due to associated quality control data.

R Associated quality control did not meet acceptance criteria.

T Analyte was positively identified but the reported concentration is estimated; reported concentration is less than the reporting limit, but greater than the method detection limit.

UJ Potential low bias, possible false negative.

TABLE 2

SEMI-VOLATILE ORGANIC COMPOUNDS SOLID SAMPLE DATA SUMMARY
DEMONSTRATION TESTING AND FULL-SCALE OPERATION OF THE BIOGENESIS SEDIMENT DECONTAMINATION PROCESS
KEASBEY, NEW JERSEY
 (Page 73 of 108)

Field Sample Identification	SS2-100406-1520	RS-100406-1525	TS-100406-1615	WS-100406-1630	RS-120406-1815	TS-120406-1835
Sediment Source	Arthur Kill	Arthur Kill	Arthur Kill	Arthur Kill	Arthur Kill	Arthur Kill
Location Identification	SS2	RS	TS	WS	RS	TS
Date Collected	4/10/06	4/10/06	4/10/06	4/10/06	4/12/06	4/12/06
Matrix	Solid	Solid	Solid	Solid	Solid	Solid
Analyte/Methods (Units)						
Semi-Volatile Organic Compounds/SW8270C (µg/kg)						
1,2,4-Trichlorobenzene	-	-	-	-	-	-
1,2-Dichlorobenzene	-	-	-	-	-	-
1,2-Diphenylhydrazine	-	-	-	-	-	-
1,3-Dichlorobenzene	-	-	-	-	-	-
1,4-Dichlorobenzene	200 TD	<5600 D	81 TD	<6300 D	<12000 D	150 TD
1,4-Dioxane (p-Dioxane)	-	-	-	-	-	-
2,3,4,6-Tetrachlorophenol	-	-	-	-	-	-
2,3,5,6-Tetrachlorophenol	-	-	-	-	-	-
2,4,5-Trichlorophenol	<3500 D	<5600 D	<2500 D	<6300 D	<12000 D	<2500 D
2,4,6-Trichlorophenol	<3500 D	<5600 D	<2500 DUJ	<6300 D	<12000 D	<2500 D
2,4-Dichlorophenol	-	-	-	-	-	-
2,4-Dimethyl phenol	-	-	-	-	-	-
2,4-Dinitrophenol	-	-	-	-	-	-
2,4-Dinitrotoluene	<3500 D	<59 D	<2500 D	<67 D	<120 D	<2500 D
2,6-Dichlorophenol	-	-	-	-	-	-
2,6-Dinitrotoluene	-	-	-	-	-	-
2-Aminonaphthalene	-	-	-	-	-	-
2-Chloronaphthalene	-	-	-	-	-	-
2-Chlorophenol	-	-	-	-	-	-
2-Methylnaphthalene	-	-	-	-	-	-
2-Methylphenol (o-Cresol)	<3500 D	<5600 D	<2500 D	<6300 D	<12000 D	<2500 D
2-Nitroaniline	-	-	-	-	-	-
2-Nitrophenol	-	-	-	-	-	-
3,3'-Dichlorobenzidine	-	-	-	-	-	-
3-Nitroaniline	-	-	-	-	-	-

TABLE 2

SEMI-VOLATILE ORGANIC COMPOUNDS SOLID SAMPLE DATA SUMMARY
DEMONSTRATION TESTING AND FULL-SCALE OPERATION OF THE BIOGENESIS SEDIMENT DECONTAMINATION PROCESS
KEASBEY, NEW JERSEY
 (Page 74 of 108)

Field Sample Identification	SS2-100406-1520	RS-100406-1525	TS-100406-1615	WS-100406-1630	RS-120406-1815	TS-120406-1835
Sediment Source	Arthur Kill	Arthur Kill	Arthur Kill	Arthur Kill	Arthur Kill	Arthur Kill
Location Identification	SS2	RS	TS	WS	RS	TS
Date Collected	4/10/06	4/10/06	4/10/06	4/10/06	4/12/06	4/12/06
Matrix	Solid	Solid	Solid	Solid	Solid	Solid
Analyte/Methods (Units)						
Semi-Volatile Organic Compounds/SW8270C (µg/kg) (continued)						
4,6-Dinitro-2-methylphenol	-	-	-	-	-	-
4-Bromophenyl phenyl ether	-	-	-	-	-	-
4-Chloro-3-methylphenol	-	-	-	-	-	-
4-Chloroaniline	-	-	-	-	-	-
4-Chlorophenyl phenyl ether	-	-	-	-	-	-
4-Methylphenol (p-Cresol)	-	-	-	-	-	-
4-Nitroaniline	-	-	-	-	-	-
4-Nitrophenol	-	-	-	-	-	-
Acenaphthene	800 TD	230 TD	150 TD	330 TD	<12000 D	170 TD
Acenaphthylene	2600 TD	470 TD	350 TDJ	370 TD	<12000 D	320 TD
Acetophenone	-	-	-	-	-	-
Aniline	-	-	-	-	-	-
Anthracene	2400 TD	620 TD	400 TDJ	<6300 D	440 TD	530 TD
Atrazine	-	-	-	-	-	-
Benzaldehyde	-	-	-	-	-	-
Benzydine	-	-	-	-	-	-
Benzo(a)anthracene	4300 D	970 TD	810 TDJ	640 TD	1100 TD	1100 TD
Benzo(a)pyrene	3200 TD	680 TD	680 TDJ	380 TD	<200 D	960 TD
Benzo(b)fluoranthene	2900 TD	680 TD	620 TDJ	410 TD	720 TD	990 TD
Benzo(g,h,i)perylene	870 TD	320 TD	300 TDJ	<6300 D	<12000 D	600 TD
Benzo(k)fluoranthene	1100 TD	250 TD	280 TDJ	<130 D	360 TD	390 TD
Benzoic acid	-	-	-	-	-	-
Benzyl alcohol	-	-	-	-	-	-
Benzyl butyl phthalate	-	-	-	-	-	-
Biphenyl (Diphenyl)	-	-	-	-	-	-

TABLE 2

SEMI-VOLATILE ORGANIC COMPOUNDS SOLID SAMPLE DATA SUMMARY
DEMONSTRATION TESTING AND FULL-SCALE OPERATION OF THE BIOGENESIS SEDIMENT DECONTAMINATION PROCESS
KEASBEY, NEW JERSEY
 (Page 75 of 108)

Field Sample Identification	SS2-100406-1520	RS-100406-1525	TS-100406-1615	WS-100406-1630	RS-120406-1815	TS-120406-1835
Sediment Source	Arthur Kill	Arthur Kill	Arthur Kill	Arthur Kill	Arthur Kill	Arthur Kill
Location Identification	SS2	RS	TS	WS	RS	TS
Date Collected	4/10/06	4/10/06	4/10/06	4/10/06	4/12/06	4/12/06
Matrix	Solid	Solid	Solid	Solid	Solid	Solid
Analyte/Methods (Units)						
Semi-Volatile Organic Compounds/SW8270C (µg/kg) (continued)						
bis(2-chloroethoxy) Methane	-	-	-	-	-	-
bis(2-chloroethyl) Ether	-	-	-	-	-	-
bis(2-chloroisopropyl) Ether	-	-	-	-	-	-
bis(2-ethylhexyl) Phthalate	-	-	-	-	-	-
Caprolactam	-	-	-	-	-	-
Carbazole	-	-	-	-	-	-
Chrysene	4800 D	970 TD	890 TDJ	<6300 D	930 TD	1300 TD
Cresols, m	<3500 D	<5600 D	<2500 D	<6300 D	<12000 D	<2500 D
Cresols, Total	-	-	-	-	-	-
Di-n-butyl phthalate	-	-	-	-	-	-
Di-n-octylphthalate	-	-	-	-	-	-
Dibenz(a,h)anthracene	230 TD	<92 D	<41 DUJ	<100 D	<190 D	<41 D
Dibenzofuran	-	-	-	-	-	-
Diethyl Phthalate	-	-	-	-	-	-
Dimethyl phthalate	-	-	-	-	-	-
Fluoranthene	14000 D	2300 TD	1800 TDJ	1800 TD	1700 TD	2200 TD
Fluorene	1600 TD	<5600 D	<2500 D	<6300 D	<12000 D	<2500 D
Hexachlorobenzene	<71 D	<110 D	<50 DUJ	<130 D	<240 D	<51 D
Hexachlorobutadiene	<3500 D	<5600 D	<2500 D	<6300 D	<12000 D	<2500 D
Hexachlorocyclopentadiene	-	-	-	-	-	-
Hexachloroethane	<3500 D	<5600 D	<2500 DUJ	<6300 D	<12000 D	<2500 D
Indeno(1,2,3-c,d)Pyrene	940 TD	260 TD	270 TDJ	<130 D	<230 D	480 TD
Isophorone	-	-	-	-	-	-
n-Nitroso-di-n-propylamine	-	-	-	-	-	-
n-Nitrosodimethylamine	-	-	-	-	-	-

TABLE 2
SEMI-VOLATILE ORGANIC COMPOUNDS SOLID SAMPLE DATA SUMMARY
DEMONSTRATION TESTING AND FULL-SCALE OPERATION OF THE BIOGENESIS SEDIMENT DECONTAMINATION PROCESS
KEASBEY, NEW JERSEY
 (Page 76 of 108)

Field Sample Identification	SS2-100406-1520	RS-100406-1525	TS-100406-1615	WS-100406-1630	RS-120406-1815	TS-120406-1835
Sediment Source	Arthur Kill	Arthur Kill	Arthur Kill	Arthur Kill	Arthur Kill	Arthur Kill
Location Identification	SS2	RS	TS	WS	RS	TS
Date Collected	4/10/06	4/10/06	4/10/06	4/10/06	4/12/06	4/12/06
Matrix	Solid	Solid	Solid	Solid	Solid	Solid
Analyte/Methods (Units)						
Semi-Volatile Organic Compounds/SW8270C (µg/kg) (continued)						
n-Nitrosodiphenylamine	-	-	-	-	-	-
Naphthalene	1900 TD	<5600 D	220 TDJ	<6300 D	<12000 D	310 TD
Nitrobenzene	<3500 D	<5600 D	<2500 D	<6300 D	<12000 D	<2500 D
Pentachlorophenol	<17000 D	<7800 D	<12000 DUJ	<8800 D	<16000 DUJ	<12000 DUJ
Phenanthrene	-	-	-	-	-	-
Phenol	-	-	-	-	-	-
Pyrene	8100 D	1700 TD	1300 TDJ	1400 TD	2000 TD	2000 TD
Pyridine	-	-	-	-	-	-

µg/kg micrograms per kilogram.
Italic Italicized result indicates analyte reported to the method detection limit.
Bold Bolded result indicates positively identified compound.
 - Not analyzed.
 B Analyte detected in an associated blank.
 D Sample dilution required for analysis; reported values reflect the dilution.
 H Sample holding time was exceeded, but the associated data are considered valid as reported.
 J Data are estimated due to associated quality control data.
 R Associated quality control did not meet acceptance criteria.
 T Analyte was positively identified but the reported concentration is estimated; reported concentration is less than the reporting limit, but greater than the method detection limit.
 UJ Potential low bias, possible false negative.

TABLE 2

SEMI-VOLATILE ORGANIC COMPOUNDS SOLID SAMPLE DATA SUMMARY
DEMONSTRATION TESTING AND FULL-SCALE OPERATION OF THE BIOGENESIS SEDIMENT DECONTAMINATION PROCESS
KEASBEY, NEW JERSEY
 (Page 77 of 108)

Field Sample Identification	WS-120406-1840	RS-170406-1725	TS-170406-1745	WS-170406-1745	PSS-200406-1600	RS-200406-1615
Sediment Source	Arthur Kill	Arthur Kill	Arthur Kill	Arthur Kill	Arthur Kill	Arthur Kill
Location Identification	WS	RS	TS	WS	PSS	RS
Date Collected	4/12/06	4/17/06	4/17/06	4/17/06	4/20/06	4/20/06
Matrix	Solid	Solid	Solid	Solid	Solid	Solid
Analyte/Methods (Units)						
Semi-Volatile Organic Compounds/SW8270C (µg/kg)						
1,2,4-Trichlorobenzene	-	-	-	-	-	-
1,2-Dichlorobenzene	-	-	-	-	-	-
1,2-Diphenylhydrazine	-	-	-	-	-	-
1,3-Dichlorobenzene	-	-	-	-	-	-
1,4-Dichlorobenzene	<5800 D	<11000 D	120 TD	<12000 D	<5500 D	100 TD
1,4-Dioxane (p-Dioxane)	-	-	-	-	-	-
2,3,4,6-Tetrachlorophenol	-	-	-	-	-	-
2,3,5,6-Tetrachlorophenol	-	-	-	-	-	-
2,4,5-Trichlorophenol	<5800 D	<11000 D	<4700 DUJ	<12000 D	<5500 D	<3400 D
2,4,6-Trichlorophenol	<5800 D	<11000 D	<4700 DUJ	<12000 D	<5500 D	<3400 D
2,4-Dichlorophenol	-	-	-	-	-	-
2,4-Dimethyl phenol	-	-	-	-	-	-
2,4-Dinitrophenol	-	-	-	-	-	-
2,4-Dinitrotoluene	<61 D	<120 D	<50 D	<120 D	<58 D	<3400 D
2,6-Dichlorophenol	-	-	-	-	-	-
2,6-Dinitrotoluene	-	-	-	-	-	-
2-Aminonaphthalene	-	-	-	-	-	-
2-Chloronaphthalene	-	-	-	-	-	-
2-Chlorophenol	-	-	-	-	-	-
2-Methylnaphthalene	-	-	-	-	-	-
2-Methylphenol (o-Cresol)	<5800 D	<11000 D	<4700 D	<12000 D	<5500 D	<3400 D
2-Nitroaniline	-	-	-	-	-	-
2-Nitrophenol	-	-	-	-	-	-
3,3'-Dichlorobenzidine	-	-	-	-	-	-
3-Nitroaniline	-	-	-	-	-	-

TABLE 2

SEMI-VOLATILE ORGANIC COMPOUNDS SOLID SAMPLE DATA SUMMARY
DEMONSTRATION TESTING AND FULL-SCALE OPERATION OF THE BIOGENESIS SEDIMENT DECONTAMINATION PROCESS
KEASBEY, NEW JERSEY
 (Page 78 of 108)

Field Sample Identification	WS-120406-1840	RS-170406-1725	TS-170406-1745	WS-170406-1745	PSS-200406-1600	RS-200406-1615
Sediment Source	Arthur Kill	Arthur Kill	Arthur Kill	Arthur Kill	Arthur Kill	Arthur Kill
Location Identification	WS	RS	TS	WS	PSS	RS
Date Collected	4/12/06	4/17/06	4/17/06	4/17/06	4/20/06	4/20/06
Matrix	Solid	Solid	Solid	Solid	Solid	Solid
Analyte/Methods (Units)						
Semi-Volatile Organic Compounds/SW8270C (µg/kg) (continued)						
4,6-Dinitro-2-methylphenol	-	-	-	-	-	-
4-Bromophenyl phenyl ether	-	-	-	-	-	-
4-Chloro-3-methylphenol	-	-	-	-	-	-
4-Chloroaniline	-	-	-	-	-	-
4-Chlorophenyl phenyl ether	-	-	-	-	-	-
4-Methylphenol (p-Cresol)	-	-	-	-	-	-
4-Nitroaniline	-	-	-	-	-	-
4-Nitrophenol	-	-	-	-	-	-
Acenaphthene	260 TD	300 TD	220 TD	430 TD	230 TD	210 TD
Acenaphthylene	230 TDJ	270 TD	230 TD	300 TD	300 TD	370 TD
Acetophenone	-	-	-	-	-	-
Aniline	-	-	-	-	-	-
Anthracene	490 TDJ	850 TD	480 TDJ	800 TD	520 TD	650 TD
Atrazine	-	-	-	-	-	-
Benzaldehyde	-	-	-	-	-	-
Benzydine	-	-	-	-	-	-
Benzo(a)anthracene	780 TDJ	1600 TD	1100 TDJ	1000 TD	960 TD	1000 TD
Benzo(a)pyrene	490 TDJ	1200 TD	1100 TDJ	930 TD	970 TD	1100 TD
Benzo(b)fluoranthene	530 TDJ	1300 TD	1300 TDJ	1200 TD	1200 TD	1300 TD
Benzo(g,h,i)perylene	<5800 D	760 TD	790 TDJ	460 TD	620 TD	820 TD
Benzo(k)fluoranthene	<110 DUJ	690 TD	530 TDJ	410 TD	420 TD	450 TD
Benzoic acid	-	-	-	-	-	-
Benzyl alcohol	-	-	-	-	-	-
Benzyl butyl phthalate	-	-	-	-	-	-
Biphenyl (Diphenyl)	-	-	-	-	-	-

TABLE 2

SEMI-VOLATILE ORGANIC COMPOUNDS SOLID SAMPLE DATA SUMMARY
DEMONSTRATION TESTING AND FULL-SCALE OPERATION OF THE BIOGENESIS SEDIMENT DECONTAMINATION PROCESS
KEASBEY, NEW JERSEY
 (Page 79 of 108)

Field Sample Identification	WS-120406-1840	RS-170406-1725	TS-170406-1745	WS-170406-1745	PSS-200406-1600	RS-200406-1615
Sediment Source	Arthur Kill	Arthur Kill	Arthur Kill	Arthur Kill	Arthur Kill	Arthur Kill
Location Identification	WS	RS	TS	WS	PSS	RS
Date Collected	4/12/06	4/17/06	4/17/06	4/17/06	4/20/06	4/20/06
Matrix	Solid	Solid	Solid	Solid	Solid	Solid
Analyte/Methods (Units)						
Semi-Volatile Organic Compounds/SW8270C (µg/kg) (continued)						
bis(2-chloroethoxy) Methane	-	-	-	-	-	-
bis(2-chloroethyl) Ether	-	-	-	-	-	-
bis(2-chloroisopropyl) Ether	-	-	-	-	-	-
bis(2-ethylhexyl) Phthalate	-	-	-	-	-	-
Caprolactam	-	-	-	-	-	-
Carbazole	-	-	-	-	-	-
Chrysene	<5800 D	2100 TD	1200 TDJ	1200 TD	1000 TD	1100 TD
Cresols, m	<5800 D	<11000 D	<4700 D	<12000 D	<5500 D	<3400 D
Cresols, Total	-	-	-	-	-	-
Di-n-butyl phthalate	-	-	-	-	-	-
Di-n-octylphthalate	-	-	-	-	-	-
Dibenz(a,h)anthracene	<96 DUJ	<180 D	<77 D	<190 D	<90 D	180 TD
Dibenzofuran	-	-	-	-	-	-
Diethyl Phthalate	-	-	-	-	-	-
Dimethyl phthalate	-	-	-	-	-	-
Fluoranthene	1800 TDJ	2300 TD	2100 TDJ	2600 TD	1900 TD	2300 TD
Fluorene	<5800 DUJ	350 TD	200 TDJ	290 TD	190 TD	210 TD
Hexachlorobenzene	<120 DUJ	<220 D	<95 D	<240 D	<110 D	<70 D
Hexachlorobutadiene	<5800 DUJ	<11000 D	<4700 D	<12000 D	<5500 D	<3400 D
Hexachlorocyclopentadiene	-	-	-	-	-	-
Hexachloroethane	<5800 DUJ	<11000 D	<4700 DUJ	<12000 D	<5500 D	<3400 D
Indeno(1,2,3-c,d)Pyrene	<120 DUJ	660 TD	650 TDJ	550 TD	480 TD	720 TD
Isophorone	-	-	-	-	-	-
n-Nitroso-di-n-propylamine	-	-	-	-	-	-
n-Nitrosodimethylamine	-	-	-	-	-	-

TABLE 2

SEMI-VOLATILE ORGANIC COMPOUNDS SOLID SAMPLE DATA SUMMARY
DEMONSTRATION TESTING AND FULL-SCALE OPERATION OF THE BIOGENESIS SEDIMENT DECONTAMINATION PROCESS
KEASBEY, NEW JERSEY
 (Page 80 of 108)

Field Sample Identification	WS-120406-1840	RS-170406-1725	TS-170406-1745	WS-170406-1745	PSS-200406-1600	RS-200406-1615
Sediment Source	Arthur Kill	Arthur Kill	Arthur Kill	Arthur Kill	Arthur Kill	Arthur Kill
Location Identification	WS	RS	TS	WS	PSS	RS
Date Collected	4/12/06	4/17/06	4/17/06	4/17/06	4/20/06	4/20/06
Matrix	Solid	Solid	Solid	Solid	Solid	Solid
Analyte/Methods (Units)						
Semi-Volatile Organic Compounds/SW8270C (µg/kg) (continued)						
n-Nitrosodiphenylamine	-	-	-	-	-	-
Naphthalene	260 TDJ	280 TD	310 TD	400 TD	680 TD	280 TD
Nitrobenzene	<5800 D	<11000 D	<4700 D	<12000 D	<5500 D	<3400 D
Pentachlorophenol	<8000 DUJ	<15000 D	<23000 D	<16000 D	<7600 D	<17000 D
Phenanthrene	-	-	-	-	-	-
Phenol	-	-	-	-	-	-
Pyrene	1700 TD	2600 TD	2200 TDJ	2900 TD	2000 TD	2200 TD
Pyridine	-	-	-	-	-	-

µg/kg micrograms per kilogram.

Italic Italicized result indicates analyte reported to the method detection limit.

Bold Bolded result indicates positively identified compound.

- Not analyzed.

B Analyte detected in an associated blank.

D Sample dilution required for analysis; reported values reflect the dilution.

H Sample holding time was exceeded, but the associated data are considered valid as reported.

J Data are estimated due to associated quality control data.

R Associated quality control did not meet acceptance criteria.

T Analyte was positively identified but the reported concentration is estimated; reported concentration is less than the reporting limit, but greater than the method detection limit.

UJ Potential low bias, possible false negative.

TABLE 2

SEMI-VOLATILE ORGANIC COMPOUNDS SOLID SAMPLE DATA SUMMARY
DEMONSTRATION TESTING AND FULL-SCALE OPERATION OF THE BIOGENESIS SEDIMENT DECONTAMINATION PROCESS
KEASBEY, NEW JERSEY
 (Page 81 of 108)

Field Sample Identification	TS-200406-1635	WS-200406-1640	RS-250406-1815	TS-250406-1835	WS-250406-1840	RS-270406-1715
Sediment Source	Arthur Kill	Arthur Kill	Arthur Kill	Arthur Kill	Arthur Kill	Arthur Kill
Location Identification	TS	WS	RS	TS	WS	RS
Date Collected	4/20/06	4/20/06	4/25/06	4/25/06	4/25/06	4/27/06
Matrix	Solid	Solid	Solid	Solid	Solid	Solid
Analyte/Methods (Units)						
Semi-Volatile Organic Compounds/SW8270C (µg/kg)						
1,2,4-Trichlorobenzene	-	-	-	-	-	-
1,2-Dichlorobenzene	-	-	-	-	-	-
1,2-Diphenylhydrazine	-	-	-	-	-	-
1,3-Dichlorobenzene	-	-	-	-	-	-
1,4-Dichlorobenzene	99 TD	<2900 D	31 T	9.4 T	<560	81 TD
1,4-Dioxane (p-Dioxane)	-	-	-	-	-	-
2,3,4,6-Tetrachlorophenol	-	-	-	-	-	-
2,3,5,6-Tetrachlorophenol	-	-	-	-	-	-
2,4,5-Trichlorophenol	<1200 D	<2900 D	<540	<240	<560	<2400 D
2,4,6-Trichlorophenol	<1200 DUJ	<2900 D	<540	<240	<560	<2400 D
2,4-Dichlorophenol	-	-	-	-	-	-
2,4-Dimethyl phenol	-	-	-	-	-	-
2,4-Dinitrophenol	-	-	-	-	-	-
2,4-Dinitrotoluene	<1200 DUJ	<2900 D	<540	<240	<560	<2400 D
2,6-Dichlorophenol	-	-	-	-	-	-
2,6-Dinitrotoluene	-	-	-	-	-	-
2-Aminonaphthalene	-	-	-	-	-	-
2-Chloronaphthalene	-	-	-	-	-	-
2-Chlorophenol	-	-	-	-	-	-
2-Methylnaphthalene	-	-	-	-	-	-
2-Methylphenol (o-Cresol)	<1200 D	<2900 D	<540	<240	<560	<2400 D
2-Nitroaniline	-	-	-	-	-	-
2-Nitrophenol	-	-	-	-	-	-
3,3'-Dichlorobenzidine	-	-	-	-	-	-
3-Nitroaniline	-	-	-	-	-	-

TABLE 2

SEMI-VOLATILE ORGANIC COMPOUNDS SOLID SAMPLE DATA SUMMARY
DEMONSTRATION TESTING AND FULL-SCALE OPERATION OF THE BIOGENESIS SEDIMENT DECONTAMINATION PROCESS
KEASBEY, NEW JERSEY
 (Page 82 of 108)

Field Sample Identification	TS-200406-1635	WS-200406-1640	RS-250406-1815	TS-250406-1835	WS-250406-1840	RS-270406-1715
Sediment Source	Arthur Kill	Arthur Kill	Arthur Kill	Arthur Kill	Arthur Kill	Arthur Kill
Location Identification	TS	WS	RS	TS	WS	RS
Date Collected	4/20/06	4/20/06	4/25/06	4/25/06	4/25/06	4/27/06
Matrix	Solid	Solid	Solid	Solid	Solid	Solid
Analyte/Methods (Units)						
Semi-Volatile Organic Compounds/SW8270C (µg/kg) (continued)						
4,6-Dinitro-2-methylphenol	-	-	-	-	-	-
4-Bromophenyl phenyl ether	-	-	-	-	-	-
4-Chloro-3-methylphenol	-	-	-	-	-	-
4-Chloroaniline	-	-	-	-	-	-
4-Chlorophenyl phenyl ether	-	-	-	-	-	-
4-Methylphenol (p-Cresol)	-	-	-	-	-	-
4-Nitroaniline	-	-	-	-	-	-
4-Nitrophenol	-	-	-	-	-	-
Acenaphthene	190 TD	140 TD	66 T	35 T	25 T	190 TD
Acenaphthylene	390 TDJ	120 TD	66 T	25 T	<560	250 TD
Acetophenone	-	-	-	-	-	-
Aniline	-	-	-	-	-	-
Anthracene	570 TDJ	260 TD	150 T	79 T	47 T	530 TD
Atrazine	-	-	-	-	-	-
Benzaldehyde	-	-	-	-	-	-
Benzydine	-	-	-	-	-	-
Benzo(a)anthracene	1000 TDJ	280 TD	320 T	170 T	63 TJ	950 TD
Benzo(a)pyrene	1100 TDJ	260 TD	340 T	160 T	58 T	860 TD
Benzo(b)fluoranthene	1200 DJ	340 TD	360 T	190 T	71 T	930 TD
Benzo(g,h,i)perylene	710 TDJ	120 TD	200 T	120 T	<560	690 TD
Benzo(k)fluoranthene	510 TDJ	130 TD	150 T	65 T	21 T	380 TD
Benzoic acid	-	-	-	-	-	-
Benzyl alcohol	-	-	-	-	-	-
Benzyl butyl phthalate	-	-	-	-	-	-
Biphenyl (Diphenyl)	-	-	-	-	-	-

TABLE 2

SEMI-VOLATILE ORGANIC COMPOUNDS SOLID SAMPLE DATA SUMMARY
DEMONSTRATION TESTING AND FULL-SCALE OPERATION OF THE BIOGENESIS SEDIMENT DECONTAMINATION PROCESS
KEASBEY, NEW JERSEY
 (Page 83 of 108)

Field Sample Identification	TS-200406-1635	WS-200406-1640	RS-250406-1815	TS-250406-1835	WS-250406-1840	RS-270406-1715
Sediment Source	Arthur Kill	Arthur Kill	Arthur Kill	Arthur Kill	Arthur Kill	Arthur Kill
Location Identification	TS	WS	RS	TS	WS	RS
Date Collected	4/20/06	4/20/06	4/25/06	4/25/06	4/25/06	4/27/06
Matrix	Solid	Solid	Solid	Solid	Solid	Solid
Analyte/Methods (Units)						
Semi-Volatile Organic Compounds/SW8270C (µg/kg) (continued)						
bis(2-chloroethoxy) Methane	-	-	-	-	-	-
bis(2-chloroethyl) Ether	-	-	-	-	-	-
bis(2-chloroisopropyl) Ether	-	-	-	-	-	-
bis(2-ethylhexyl) Phthalate	-	-	-	-	-	-
Caprolactam	-	-	-	-	-	-
Carbazole	-	-	-	-	-	-
Chrysene	1200 DJ	340 TD	350 T	190 T	77 TJ	1000 TD
Cresols, m	<1200 D	<2900 D	<540	<240	<560	<2400 D
Cresols, Total	-	-	-	-	-	-
Di-n-butyl phthalate	-	-	-	-	-	-
Di-n-octylphthalate	-	-	-	-	-	-
Dibenz(a,h)anthracene	140 TDJ	<49 D	47 T	<240	<560	160 TD
Dibenzofuran	-	-	-	-	-	-
Diethyl Phthalate	-	-	-	-	-	-
Dimethyl phthalate	-	-	-	-	-	-
Fluoranthene	2400 DJ	800 TD	590	340	150 TJ	1900 TD
Fluorene	210 TDJ	130 TD	74 T	34 T	23 T	170 TD
Hexachlorobenzene	<1200 DUJ	<60 D	<540	<240	<560	<49 D
Hexachlorobutadiene	<1200 D	<2900 D	<540	<240	<560	<2400 D
Hexachlorocyclopentadiene	-	-	-	-	-	-
Hexachloroethane	<1200 DUJ	<2900 D	<540	<240	<560	<2400 D
Indeno(1,2,3-c,d)Pyrene	750 TDJ	110 TD	170 T	89 T	<560	660 TD
Isophorone	-	-	-	-	-	-
n-Nitroso-di-n-propylamine	-	-	-	-	-	-
n-Nitrosodimethylamine	-	-	-	-	-	-

TABLE 2
SEMI-VOLATILE ORGANIC COMPOUNDS SOLID SAMPLE DATA SUMMARY
DEMONSTRATION TESTING AND FULL-SCALE OPERATION OF THE BIOGENESIS SEDIMENT DECONTAMINATION PROCESS
KEASBEY, NEW JERSEY
 (Page 84 of 108)

Field Sample Identification	TS-200406-1635	WS-200406-1640	RS-250406-1815	TS-250406-1835	WS-250406-1840	RS-270406-1715
Sediment Source	Arthur Kill	Arthur Kill	Arthur Kill	Arthur Kill	Arthur Kill	Arthur Kill
Location Identification	TS	WS	RS	TS	WS	RS
Date Collected	4/20/06	4/20/06	4/25/06	4/25/06	4/25/06	4/27/06
Matrix	Solid	Solid	Solid	Solid	Solid	Solid
Analyte/Methods (Units)						
Semi-Volatile Organic Compounds/SW8270C (µg/kg) (continued)						
n-Nitrosodiphenylamine	-	-	-	-	-	-
Naphthalene	320 TDJ	110 TD	85 T	41 T	20 T	220 TD
Nitrobenzene	<1200 D	<2900 D	<540	<240	<560	<2400 D
Pentachlorophenol	<5800 D	<14000 D	<2600	<1200	<2700	<12000 D
Phenanthrene	-	-	-	-	-	-
Phenol	-	-	-	-	-	-
Pyrene	1900 DJ	820 TD	700	360	200 TJ	1800 TD
Pyridine	-	-	-	-	-	-

µg/kg micrograms per kilogram.
Italic Italicized result indicates analyte reported to the method detection limit.
Bold Bolded result indicates positively identified compound.
 - Not analyzed.
 B Analyte detected in an associated blank.
 D Sample dilution required for analysis; reported values reflect the dilution.
 H Sample holding time was exceeded, but the associated data are considered valid as reported.
 J Data are estimated due to associated quality control data.
 R Associated quality control did not meet acceptance criteria.
 T Analyte was positively identified but the reported concentration is estimated; reported concentration is less than the reporting limit, but greater than the method detection limit.
 UJ Potential low bias, possible false negative.

TABLE 2

SEMI-VOLATILE ORGANIC COMPOUNDS SOLID SAMPLE DATA SUMMARY
DEMONSTRATION TESTING AND FULL-SCALE OPERATION OF THE BIOGENESIS SEDIMENT DECONTAMINATION PROCESS
KEASBEY, NEW JERSEY
 (Page 85 of 108)

Field Sample Identification	TS-270406-1735	WS-270406-1740	PSS-010506-1600	RS-010506-1615	TS-010506-1635	TS3-010506-1630
Sediment Source	Arthur Kill	Arthur Kill	Lower Passaic River	Lower Passaic River	Lower Passaic River	Lower Passaic River
Location Identification	TS	WS	PSS	RS	TS	TS3
Date Collected	4/27/06	4/27/06	5/1/06	5/1/06	5/1/06	5/1/06
Matrix	Solid	Solid	Solid	Solid	Solid	Solid
Analyte/Methods (Units)						
Semi-Volatile Organic Compounds/SW8270C (µg/kg)						
1,2,4-Trichlorobenzene	-	-	-	-	-	-
1,2-Dichlorobenzene	-	-	-	-	-	-
1,2-Diphenylhydrazine	-	-	-	-	-	-
1,3-Dichlorobenzene	-	-	-	-	-	-
1,4-Dichlorobenzene	130 TD	<3300 D	<16000 D	<14000 D	240 TD	220 TD
1,4-Dioxane (p-Dioxane)	-	-	-	-	-	-
2,3,4,6-Tetrachlorophenol	-	-	-	-	-	-
2,3,5,6-Tetrachlorophenol	-	-	-	-	-	-
2,4,5-Trichlorophenol	<1300 D	<3300 D	<16000 D	<14000 D	<5300 D	<5100 D
2,4,6-Trichlorophenol	<1300 D	<3300 D	<16000 D	<14000 D	<5300 D	<5100 D
2,4-Dichlorophenol	-	-	-	-	-	-
2,4-Dimethyl phenol	-	-	-	-	-	-
2,4-Dinitrophenol	-	-	-	-	-	-
2,4-Dinitrotoluene	<1300 D	<3300 D	<170 D	<150 D	<56 D	<54 D
2,6-Dichlorophenol	-	-	-	-	-	-
2,6-Dinitrotoluene	-	-	-	-	-	-
2-Aminonaphthalene	-	-	-	-	-	-
2-Chloronaphthalene	-	-	-	-	-	-
2-Chlorophenol	-	-	-	-	-	-
2-Methylnaphthalene	-	-	-	-	-	-
2-Methylphenol (o-Cresol)	<1300 D	<3300 D	<16000 D	<14000 D	<5300 D	<5100 D
2-Nitroaniline	-	-	-	-	-	-
2-Nitrophenol	-	-	-	-	-	-
3,3'-Dichlorobenzidine	-	-	-	-	-	-
3-Nitroaniline	-	-	-	-	-	-

TABLE 2

SEMI-VOLATILE ORGANIC COMPOUNDS SOLID SAMPLE DATA SUMMARY
DEMONSTRATION TESTING AND FULL-SCALE OPERATION OF THE BIOGENESIS SEDIMENT DECONTAMINATION PROCESS
KEASBEY, NEW JERSEY
 (Page 86 of 108)

Field Sample Identification	TS-270406-1735	WS-270406-1740	PSS-010506-1600	RS-010506-1615	TS-010506-1635	TS3-010506-1630
Sediment Source	Arthur Kill	Arthur Kill	Lower Passaic River	Lower Passaic River	Lower Passaic River	Lower Passaic River
Location Identification	TS	WS	PSS	RS	TS	TS3
Date Collected	4/27/06	4/27/06	5/1/06	5/1/06	5/1/06	5/1/06
Matrix	Solid	Solid	Solid	Solid	Solid	Solid
Analyte/Methods (Units)						
Semi-Volatile Organic Compounds/SW8270C (µg/kg) (continued)						
4,6-Dinitro-2-methylphenol	-	-	-	-	-	-
4-Bromophenyl phenyl ether	-	-	-	-	-	-
4-Chloro-3-methylphenol	-	-	-	-	-	-
4-Chloroaniline	-	-	-	-	-	-
4-Chlorophenyl phenyl ether	-	-	-	-	-	-
4-Methylphenol (p-Cresol)	-	-	-	-	-	-
4-Nitroaniline	-	-	-	-	-	-
4-Nitrophenol	-	-	-	-	-	-
Acenaphthene	200 TD	240 TD	<16000 D	<14000 D	250 TD	260 TD
Acenaphthylene	330 TD	200 TD	510 TD	390 TD	380 TD	350 TD
Acetophenone	-	-	-	-	-	-
Aniline	-	-	-	-	-	-
Anthracene	600 TD	450 TD	770 TD	540 TD	640 TD	630 TDJ
Atrazine	-	-	-	-	-	-
Benzaldehyde	-	-	-	-	-	-
Benzidine	-	-	-	-	-	-
Benzo(a)anthracene	980 TD	490 TD	2300 TD	1600 TD	1700 TD	1700 TDJ
Benzo(a)pyrene	990 TD	410 TD	2300 TD	1700 TD	1800 TD	1700 TDJ
Benzo(b)fluoranthene	1000 TD	470 TD	2800 TD	2000 TD	2100 TD	1900 TD
Benzo(g,h,i)perylene	670 TD	260 TDJ	1500 TD	1200 TD	890 TD	950 TD
Benzo(k)fluoranthene	400 TD	180 TD	1100 TD	840 TD	850 TD	810 TD
Benzoic acid	-	-	-	-	-	-
Benzyl alcohol	-	-	-	-	-	-
Benzyl butyl phthalate	-	-	-	-	-	-
Biphenyl (Diphenyl)	-	-	-	-	-	-

TABLE 2

SEMI-VOLATILE ORGANIC COMPOUNDS SOLID SAMPLE DATA SUMMARY
DEMONSTRATION TESTING AND FULL-SCALE OPERATION OF THE BIOGENESIS SEDIMENT DECONTAMINATION PROCESS
KEASBEY, NEW JERSEY
 (Page 87 of 108)

Field Sample Identification	TS-270406-1735	WS-270406-1740	PSS-010506-1600	RS-010506-1615	TS-010506-1635	TS3-010506-1630
Sediment Source	Arthur Kill	Arthur Kill	Lower Passaic River	Lower Passaic River	Lower Passaic River	Lower Passaic River
Location Identification	TS	WS	PSS	RS	TS	TS3
Date Collected	4/27/06	4/27/06	5/1/06	5/1/06	5/1/06	5/1/06
Matrix	Solid	Solid	Solid	Solid	Solid	Solid
Analyte/Methods (Units)						
Semi-Volatile Organic Compounds/SW8270C (µg/kg) (continued)						
bis(2-chloroethoxy) Methane	-	-	-	-	-	-
bis(2-chloroethyl) Ether	-	-	-	-	-	-
bis(2-chloroisopropyl) Ether	-	-	-	-	-	-
bis(2-ethylhexyl) Phthalate	-	-	-	-	-	-
Caprolactam	-	-	-	-	-	-
Carbazole	-	-	-	-	-	-
Chrysene	1100 TD	590 TD	2900 TD	2100 TD	2200 TD	2100 TDJ
Cresols, m	<1300 D	<3300 D	<16000 D	<14000 D	<5300 D	<5100 D
Cresols, Total	-	-	-	-	-	-
Di-n-butyl phthalate	-	-	-	-	-	-
Di-n-octylphthalate	-	-	-	-	-	-
Dibenz(a,h)anthracene	160 TD	71 TD	<270 D	<230 D	<88 D	210 TD
Dibenzofuran	-	-	-	-	-	-
Diethyl Phthalate	-	-	-	-	-	-
Dimethyl phthalate	-	-	-	-	-	-
Fluoranthene	2100 D	1300 TD	4900 TD	3400 TD	3700 TD	3400 TDJ
Fluorene	190 TD	150 TD	<16000 D	<14000 D	290 TD	280 TD
Hexachlorobenzene	<1300 D	<67 D	<330 D	<280 D	<110 D	<100 D
Hexachlorobutadiene	<1300 D	<3300 D	<16000 D	<14000 D	<5300 D	<5100 D
Hexachlorocyclopentadiene	-	-	-	-	-	-
Hexachloroethane	<1300 D	<3300 DUJ	<16000 D	<14000 D	<5300 D	<5100 D
Indeno(1,2,3-c,d)Pyrene	690 TD	280 TD	1500 TD	1200 TD	970 TD	970 TD
Isophorone	-	-	-	-	-	-
n-Nitroso-di-n-propylamine	-	-	-	-	-	-
n-Nitrosodimethylamine	-	-	-	-	-	-

TABLE 2
SEMI-VOLATILE ORGANIC COMPOUNDS SOLID SAMPLE DATA SUMMARY
DEMONSTRATION TESTING AND FULL-SCALE OPERATION OF THE BIOGENESIS SEDIMENT DECONTAMINATION PROCESS
KEASBEY, NEW JERSEY
 (Page 88 of 108)

Field Sample Identification	TS-270406-1735	WS-270406-1740	PSS-010506-1600	RS-010506-1615	TS-010506-1635	TS3-010506-1630
Sediment Source	Arthur Kill	Arthur Kill	Lower Passaic River	Lower Passaic River	Lower Passaic River	Lower Passaic River
Location Identification	TS	WS	PSS	RS	TS	TS3
Date Collected	4/27/06	4/27/06	5/1/06	5/1/06	5/1/06	5/1/06
Matrix	Solid	Solid	Solid	Solid	Solid	Solid
Analyte/Methods (Units)						
Semi-Volatile Organic Compounds/SW8270C (µg/kg) (continued)						
n-Nitrosodiphenylamine	-	-	-	-	-	-
Naphthalene	350 TD	190 TD	<16000 D	<14000 D	350 TD	350 TDJ
Nitrobenzene	<1300 D	<3300 D	<16000 D	<14000 D	<5300 D	<5100 D
Pentachlorophenol	<6100 D	<16000 D	<23000 D	<19000 D	<7400 D	<7100 D
Phenanthrene	-	-	-	-	-	-
Phenol	-	-	-	-	-	-
Pyrene	1900 D	1300 TD	4800 TD	3300 TD	3300 TD	3200 TDJ
Pyridine	-	-	-	-	-	-

µg/kg micrograms per kilogram.
Italic Italicized result indicates analyte reported to the method detection limit.
Bold Bolded result indicates positively identified compound.
 - Not analyzed.
 B Analyte detected in an associated blank.
 D Sample dilution required for analysis; reported values reflect the dilution.
 H Sample holding time was exceeded, but the associated data are considered valid as reported.
 J Data are estimated due to associated quality control data.
 R Associated quality control did not meet acceptance criteria.
 T Analyte was positively identified but the reported concentration is estimated; reported concentration is less than the reporting limit, but greater than the method detection limit.
 UJ Potential low bias, possible false negative.

TABLE 2

SEMI-VOLATILE ORGANIC COMPOUNDS SOLID SAMPLE DATA SUMMARY
DEMONSTRATION TESTING AND FULL-SCALE OPERATION OF THE BIOGENESIS SEDIMENT DECONTAMINATION PROCESS
KEASBEY, NEW JERSEY
 (Page 89 of 108)

Field Sample Identification	WS-010506-1640	PSS-030506-1600	RS-030506-1615	STS-3-030506-1200	STS-4-030506-1400	TS-030506-1635
Sediment Source	Lower Passaic River	Lower Passaic River	Lower Passaic River	Lower Passaic River	Lower Passaic River	Lower Passaic River
Location Identification	WS	PSS	RS	TS	TS	TS
Date Collected	5/1/06	5/3/06	5/3/06	5/3/06	5/3/06	5/3/06
Matrix	Solid	Solid	Solid	Solid	Solid	Solid
Analyte/Methods (Units)						
Semi-Volatile Organic Compounds/SW8270C (µg/kg)						
1,2,4-Trichlorobenzene	-	-	-	-	-	-
1,2-Dichlorobenzene	-	-	-	-	-	-
1,2-Diphenylhydrazine	-	-	-	-	-	-
1,3-Dichlorobenzene	-	-	-	-	-	-
1,4-Dichlorobenzene	<12000 D	190 TD	230 TD	240 TD	240 TD	170 TD
1,4-Dioxane (p-Dioxane)	-	-	-	-	-	-
2,3,4,6-Tetrachlorophenol	-	-	-	-	-	-
2,3,5,6-Tetrachlorophenol	-	-	-	-	-	-
2,4,5-Trichlorophenol	<12000 D	<3100 D	<3200 D	<1200 D	<1200 D	<1200 D
2,4,6-Trichlorophenol	<12000 D	<3100 D	<3200 D	<1200 D	<1200 D	<1200 D
2,4-Dichlorophenol	-	-	-	-	-	-
2,4-Dimethyl phenol	-	-	-	-	-	-
2,4-Dinitrophenol	-	-	-	-	-	-
2,4-Dinitrotoluene	<130 D	<3100 D	<3200 D	<1200 D	<1200 D	<1200 D
2,6-Dichlorophenol	-	-	-	-	-	-
2,6-Dinitrotoluene	-	-	-	-	-	-
2-Aminonaphthalene	-	-	-	-	-	-
2-Chloronaphthalene	-	-	-	-	-	-
2-Chlorophenol	-	-	-	-	-	-
2-Methylnaphthalene	-	-	-	-	-	-
2-Methylphenol (o-Cresol)	<12000 D	<3100 D	<3200 D	<1200 D	<1200 D	<1200 D
2-Nitroaniline	-	-	-	-	-	-
2-Nitrophenol	-	-	-	-	-	-
3,3'-Dichlorobenzidine	-	-	-	-	-	-
3-Nitroaniline	-	-	-	-	-	-

TABLE 2

SEMI-VOLATILE ORGANIC COMPOUNDS SOLID SAMPLE DATA SUMMARY
DEMONSTRATION TESTING AND FULL-SCALE OPERATION OF THE BIOGENESIS SEDIMENT DECONTAMINATION PROCESS
KEASBEY, NEW JERSEY
 (Page 90 of 108)

Field Sample Identification	WS-010506-1640	PSS-030506-1600	RS-030506-1615	STS-3-030506-1200	STS-4-030506-1400	TS-030506-1635
Sediment Source	Lower Passaic River	Lower Passaic River	Lower Passaic River	Lower Passaic River	Lower Passaic River	Lower Passaic River
Location Identification	WS	PSS	RS	TS	TS	TS
Date Collected	5/1/06	5/3/06	5/3/06	5/3/06	5/3/06	5/3/06
Matrix	Solid	Solid	Solid	Solid	Solid	Solid
Analyte/Methods (Units)						
Semi-Volatile Organic Compounds/SW8270C (µg/kg) (continued)						
4,6-Dinitro-2-methylphenol	-	-	-	-	-	-
4-Bromophenyl phenyl ether	-	-	-	-	-	-
4-Chloro-3-methylphenol	-	-	-	-	-	-
4-Chloroaniline	-	-	-	-	-	-
4-Chlorophenyl phenyl ether	-	-	-	-	-	-
4-Methylphenol (p-Cresol)	-	-	-	-	-	-
4-Nitroaniline	-	-	-	-	-	-
4-Nitrophenol	-	-	-	-	-	-
Acenaphthene	<12000 D	240 TD	300 TD	270 TD	270 TD	190 TD
Acenaphthylene	<12000 D	560 TD	700 TD	560 TD	600 TD	380 TD
Acetophenone	-	-	-	-	-	-
Aniline	-	-	-	-	-	-
Anthracene	410 TD	790 TD	960 TD	850 TD	910 TD	630 TD
Atrazine	-	-	-	-	-	-
Benzaldehyde	-	-	-	-	-	-
Benzydine	-	-	-	-	-	-
Benzo(a)anthracene	650 TD	2000 TD	2300 TD	2000 D	2100 D	1500 D
Benzo(a)pyrene	580 TD	1900 TD	2300 TD	2000 D	2200 D	1400 D
Benzo(b)fluoranthene	840 TD	2100 TD	2600 TD	2600 D	2900 D	1700 D
Benzo(g,h,i)perylene	390 TD	1400 TD	1300 TD	650 TD	640 TD	590 TD
Benzo(k)fluoranthene	320 TD	900 TD	1000 TD	1100 TD	1200 D	720 TD
Benzoic acid	-	-	-	-	-	-
Benzyl alcohol	-	-	-	-	-	-
Benzyl butyl phthalate	-	-	-	-	-	-
Biphenyl (Diphenyl)	-	-	-	-	-	-

TABLE 2

SEMI-VOLATILE ORGANIC COMPOUNDS SOLID SAMPLE DATA SUMMARY
DEMONSTRATION TESTING AND FULL-SCALE OPERATION OF THE BIOGENESIS SEDIMENT DECONTAMINATION PROCESS
KEASBEY, NEW JERSEY
 (Page 91 of 108)

Field Sample Identification	WS-010506-1640	PSS-030506-1600	RS-030506-1615	STS-3-030506-1200	STS-4-030506-1400	TS-030506-1635
Sediment Source	Lower Passaic River	Lower Passaic River	Lower Passaic River	Lower Passaic River	Lower Passaic River	Lower Passaic River
Location Identification	WS	PSS	RS	TS	TS	TS
Date Collected	5/1/06	5/3/06	5/3/06	5/3/06	5/3/06	5/3/06
Matrix	Solid	Solid	Solid	Solid	Solid	Solid
Analyte/Methods (Units)						
Semi-Volatile Organic Compounds/SW8270C (µg/kg) (continued)						
bis(2-chloroethoxy) Methane	-	-	-	-	-	-
bis(2-chloroethyl) Ether	-	-	-	-	-	-
bis(2-chloroisopropyl) Ether	-	-	-	-	-	-
bis(2-ethylhexyl) Phthalate	-	-	-	-	-	-
Caprolactam	-	-	-	-	-	-
Carbazole	-	-	-	-	-	-
Chrysene	880 TD	2600 TD	3000 TD	2400 D	2500 D	1900 D
Cresols, m	<12000 D	<3100 D	<3200 D	310 TD	290 TD	230 TD
Cresols, Total	-	-	-	-	-	-
Di-n-butyl phthalate	-	-	-	-	-	-
Di-n-octylphthalate	-	-	-	-	-	-
Dibenz(a,h)anthracene	<200 D	310 TD	300 TD	170 TD	170 TD	150 TD
Dibenzofuran	-	-	-	-	-	-
Diethyl Phthalate	-	-	-	-	-	-
Dimethyl phthalate	-	-	-	-	-	-
Fluoranthene	1800 TD	3900 D	5100 D	4900 D	5200 D	3600 D
Fluorene	<12000 D	290 TD	340 TD	320 TD	330 TD	230 TD
Hexachlorobenzene	<250 D	<63 D	<65 D	<1200 D	<1200 D	<1200 D
Hexachlorobutadiene	<12000 D	<3100 D	<3200 D	<1200 D	<1200 D	<1200 D
Hexachlorocyclopentadiene	-	-	-	-	-	-
Hexachloroethane	<12000 D	<3100 D	<3200 D	<1200 D	<1200 D	<1200 D
Indeno(1,2,3-c,d)Pyrene	320 TD	1500 TD	1400 TD	750 TD	750 TD	660 TD
Isophorone	-	-	-	-	-	-
n-Nitroso-di-n-propylamine	-	-	-	-	-	-
n-Nitrosodimethylamine	-	-	-	-	-	-

TABLE 2

SEMI-VOLATILE ORGANIC COMPOUNDS SOLID SAMPLE DATA SUMMARY
DEMONSTRATION TESTING AND FULL-SCALE OPERATION OF THE BIOGENESIS SEDIMENT DECONTAMINATION PROCESS
KEASBEY, NEW JERSEY
 (Page 92 of 108)

Field Sample Identification	WS-010506-1640	PSS-030506-1600	RS-030506-1615	STS-3-030506-1200	STS-4-030506-1400	TS-030506-1635
Sediment Source	Lower Passaic River	Lower Passaic River	Lower Passaic River	Lower Passaic River	Lower Passaic River	Lower Passaic River
Location Identification	WS	PSS	RS	TS	TS	TS
Date Collected	5/1/06	5/3/06	5/3/06	5/3/06	5/3/06	5/3/06
Matrix	Solid	Solid	Solid	Solid	Solid	Solid
Analyte/Methods (Units)						
Semi-Volatile Organic Compounds/SW8270C (µg/kg) (continued)						
n-Nitrosodiphenylamine	-	-	-	-	-	-
Naphthalene	<12000 D	350 TD	340 TD	350 TD	340 TD	260 TD
Nitrobenzene	<12000 D	<3100 D	<3200 D	<1200 D	<1200 D	<1200 D
Pentachlorophenol	<17000 D	<15000 DUJ	<15000 DUJ	<6100 DUJ	<6000 DUJ	<5900 DUJ
Phenanthrene	-	-	-	-	-	-
Phenol	-	-	-	-	-	-
Pyrene	1700 TD	3900 D	4500 D	3200 D	3200 D	2700 D
Pyridine	-	-	-	-	-	-

µg/kg micrograms per kilogram.

Italic Italicized result indicates analyte reported to the method detection limit.

Bold Bolded result indicates positively identified compound.

- Not analyzed.

B Analyte detected in an associated blank.

D Sample dilution required for analysis; reported values reflect the dilution.

H Sample holding time was exceeded, but the associated data are considered valid as reported.

J Data are estimated due to associated quality control data.

R Associated quality control did not meet acceptance criteria.

T Analyte was positively identified but the reported concentration is estimated; reported concentration is less than the reporting limit, but greater than the method detection limit.

UJ Potential low bias, possible false negative.

TABLE 2

SEMI-VOLATILE ORGANIC COMPOUNDS SOLID SAMPLE DATA SUMMARY
DEMONSTRATION TESTING AND FULL-SCALE OPERATION OF THE BIOGENESIS SEDIMENT DECONTAMINATION PROCESS
KEASBEY, NEW JERSEY
 (Page 93 of 108)

Field Sample Identification	WS-030506-1640	SPC COMP-160506-1700	SPP COMP-170506-1030	MSL01-040107-0905	MSL02-040107-0925	MSL03-040107-0940
Sediment Source	Lower Passaic River	All	All	Lower Passaic River	Lower Passaic River	Lower Passaic River
Location Identification	WS	TSP	TSP	MSL	MSL	MSL
Date Collected	5/3/06	5/16/06	5/17/06	1/4/07	1/4/07	1/4/07
Matrix	Solid	Solid	Solid	Solid	Solid	Solid
Analyte/Methods (Units)						
Semi-Volatile Organic Compounds/SW8270C (µg/kg)						
1,2,4-Trichlorobenzene	-	<6000 D	<4700 D	-	-	-
1,2-Dichlorobenzene	-	<6000 D	110 TD	-	-	-
1,2-Diphenylhydrazine	-	<6000 D	-	-	-	-
1,3-Dichlorobenzene	-	<6000 D	<4700 D	-	-	-
1,4-Dichlorobenzene	98 TD	<6000 D	270 TD	65 TD	49 TD	54 TD
1,4-Dioxane (p-Dioxane)	-	<6000 D	-	-	-	-
2,3,4,6-Tetrachlorophenol	-	<6000 D	-	-	-	-
2,3,5,6-Tetrachlorophenol	-	<6000 D	-	-	-	-
2,4,5-Trichlorophenol	<3200 D	<6000 D	<4700 D	<2100 D	<2100 D	<2100 D
2,4,6-Trichlorophenol	<3200 D	<6000 D	<4700 D	<2100 D	<2100 D	<2100 D
2,4-Dichlorophenol	-	<6000 D	<4700 D	-	-	-
2,4-Dimethyl phenol	-	<6000 D	<4700 D	-	-	-
2,4-Dinitrophenol	-	<29000 D	<23000 D	-	-	-
2,4-Dinitrotoluene	<3200 D	<6000 D	<4700 D	<2100 D	<2100 D	<2100 D
2,6-Dichlorophenol	-	<6000 D	-	-	-	-
2,6-Dinitrotoluene	-	<6000 D	-	-	-	-
2-Aminonaphthalene	-	<6000 D	-	-	-	-
2-Chloronaphthalene	-	<6000 D	-	-	-	-
2-Chlorophenol	-	<6000 D	<4700 D	-	-	-
2-Methylnaphthalene	-	240 TD	-	-	-	-
2-Methylphenol (o-Cresol)	<3200 D	<6000 D	<4700 D	<2100 D	<2100 D	<2100 D
2-Nitroaniline	-	<29000 D	-	-	-	-
2-Nitrophenol	-	<6000 D	-	-	-	-
3,3'-Dichlorobenzidine	-	<29000 D	<23000 D	-	-	-
3-Nitroaniline	-	<29000 D	-	-	-	-

TABLE 2

SEMI-VOLATILE ORGANIC COMPOUNDS SOLID SAMPLE DATA SUMMARY
DEMONSTRATION TESTING AND FULL-SCALE OPERATION OF THE BIOGENESIS SEDIMENT DECONTAMINATION PROCESS
KEASBEY, NEW JERSEY
 (Page 94 of 108)

Field Sample Identification	WS-030506-1640	SPC COMP-160506-1700	SPP COMP-170506-1030	MSL01-040107-0905	MSL02-040107-0925	MSL03-040107-0940
Sediment Source	Lower Passaic River	All	All	Lower Passaic River	Lower Passaic River	Lower Passaic River
Location Identification	WS	TSP	TSP	MSL	MSL	MSL
Date Collected	5/3/06	5/16/06	5/17/06	1/4/07	1/4/07	1/4/07
Matrix	Solid	Solid	Solid	Solid	Solid	Solid
Analyte/Methods (Units)						
Semi-Volatile Organic Compounds/SW8270C (µg/kg) (continued)						
4,6-Dinitro-2-methylphenol	-	<29000 D	-	-	-	-
4-Bromophenyl phenyl ether	-	<6000 D	-	-	-	-
4-Chloro-3-methylphenol	-	<6000 D	<4700 D	-	-	-
4-Chloroaniline	-	<6000 D	400 TD	-	-	-
4-Chlorophenyl phenyl ether	-	<6000 D	-	-	-	-
4-Methylphenol (p-Cresol)	-	<6000 D	-	-	-	-
4-Nitroaniline	-	<29000 D	-	-	-	-
4-Nitrophenol	-	<29000 D	-	-	-	-
Acenaphthene	190 TD	250 TD	290 TD	87 TD	76 TD	110 TD
Acenaphthylene	360 TD	290 TD	490 TD	240 TD	150 TD	210 TD
Acetophenone	-	-	-	-	-	-
Aniline	-	<6000 D	-	-	-	-
Anthracene	520 TD	510 TD	840 TD	360 TD	200 TD	270 TD
Atrazine	-	-	-	-	-	-
Benzaldehyde	-	-	-	-	-	-
Benzydine	-	<6000 D	-	-	-	-
Benzo(a)anthracene	910 TD	870 TD	2200 TD	860 TD	440 TD	580 TD
Benzo(a)pyrene	860 TD	900 TD	2200 TD	750 TD	450 TD	540 TD
Benzo(b)fluoranthene	1300 TD	1000 TD	2500 TD	790 TD	440 TD	560 TD
Benzo(g,h,i)perylene	360 TDJ	660 TD	1700 TD	540 TD	360 TD	440 TD
Benzo(k)fluoranthene	510 TD	390 TD	960 TD	380 TD	180 TD	240 TD
Benzoic acid	-	<29000 D	-	-	-	-
Benzyl alcohol	-	<6000 D	<4700 D	-	-	-
Benzyl butyl phthalate	-	<6000 D	490 TD	-	-	-
Biphenyl (Diphenyl)	-	-	-	-	-	-

TABLE 2

SEMI-VOLATILE ORGANIC COMPOUNDS SOLID SAMPLE DATA SUMMARY
DEMONSTRATION TESTING AND FULL-SCALE OPERATION OF THE BIOGENESIS SEDIMENT DECONTAMINATION PROCESS
KEASBEY, NEW JERSEY
 (Page 95 of 108)

Field Sample Identification	WS-030506-1640	SPC COMP-160506-1700	SPP COMP-170506-1030	MSL01-040107-0905	MSL02-040107-0925	MSL03-040107-0940
Sediment Source	Lower Passaic River	All	All	Lower Passaic River	Lower Passaic River	Lower Passaic River
Location Identification	WS	TSP	TSP	MSL	MSL	MSL
Date Collected	5/3/06	5/16/06	5/17/06	1/4/07	1/4/07	1/4/07
Matrix	Solid	Solid	Solid	Solid	Solid	Solid
Analyte/Methods (Units)						
Semi-Volatile Organic Compounds/SW8270C (µg/kg) (continued)						
bis(2-chloroethoxy) Methane	-	<6000 D	-	-	-	-
bis(2-chloroethyl) Ether	-	<6000 D	<4700 D	-	-	-
bis(2-chloroisopropyl) Ether	-	<6000 D	<4700 D	-	-	-
bis(2-ethylhexyl) Phthalate	-	8500 D	35000 D	-	-	-
Caprolactam	-	-	-	-	-	-
Carbazole	-	<6000 D	-	-	-	-
Chrysene	1200 TD	1000 TD	2800 TD	1100 TD	620 TD	760 TD
Cresols, m	<3200 D	<6000 D	<4700 D	<2100 D	<2100 D	<2100 D
Cresols, Total	-	-	-	-	-	-
Di-n-butyl phthalate	-	<6000 D	<4700 D	-	-	-
Di-n-octylphthalate	-	<6000 D	<4700 D	-	-	-
Dibenz(a,h)anthracene	95 TD	<6000 D	390 TD	120 TD	<2100 D	<2100 D
Dibenzofuran	-	<6000 D	-	-	-	-
Diethyl Phthalate	-	<6000 D	<4700 D	-	-	-
Dimethyl phthalate	-	<6000 D	<4700 D	-	-	-
Fluoranthene	2800 TD	1900 TD	4800 D	1400 TD	660 TD	960 TD
Fluorene	180 TD	210 TD	290 TD	150 TD	97 TD	150 TD
Hexachlorobenzene	<64 D	<6000 D	<4700 D	<2100 D	<2100 D	<2100 D
Hexachlorobutadiene	<3200 D	<6000 D	<4700 D	<2100 D	<2100 D	<2100 D
Hexachlorocyclopentadiene	-	<29000 D	<23000 D	-	-	-
Hexachloroethane	<3200 DUJ	<6000 D	<4700 D	<2100 D	<2100 D	<2100 D
Indeno(1,2,3-c,d)Pyrene	410 TDJ	580 TD	1600 TD	500 TD	280 TD	370 TD
Isophorone	-	<6000 D	<4700 D	-	-	-
n-Nitroso-di-n-propylamine	-	<6000 D	<4700 D	-	-	-
n-Nitrosodimethylamine	-	<6000 D	-	-	-	-

TABLE 2

SEMI-VOLATILE ORGANIC COMPOUNDS SOLID SAMPLE DATA SUMMARY
DEMONSTRATION TESTING AND FULL-SCALE OPERATION OF THE BIOGENESIS SEDIMENT DECONTAMINATION PROCESS
KEASBEY, NEW JERSEY
 (Page 96 of 108)

Field Sample Identification	WS-030506-1640	SPC COMP-160506-1700	SPP COMP-170506-1030	MSL01-040107-0905	MSL02-040107-0925	MSL03-040107-0940
Sediment Source	Lower Passaic River	All	All	Lower Passaic River	Lower Passaic River	Lower Passaic River
Location Identification	WS	TSP	TSP	MSL	MSL	MSL
Date Collected	5/3/06	5/16/06	5/17/06	1/4/07	1/4/07	1/4/07
Matrix	Solid	Solid	Solid	Solid	Solid	Solid
Analyte/Methods (Units)						
Semi-Volatile Organic Compounds/SW8270C (µg/kg) (continued)						
n-Nitrosodiphenylamine	-	<6000 D	<4700 D	-	-	-
Naphthalene	170 TD	440 TD	410 TD	110 TD	89 TD	110 TD
Nitrobenzene	<3200 D	<6000 D	<4700 D	<2100 D	<2100 D	<2100 D
Pentachlorophenol	<15000 DUJ	<29000 DR	<23000 DR	<10000 D	<10000 D	<10000 D
Phenanthrene	-	980 TD	-	-	-	-
Phenol	-	<6000 D	<4700 D	-	-	-
Pyrene	2100 TD	1600 TD	3700 TD	1400 TD	730 TD	970 TD
Pyridine	-	<12000 D	-	-	-	-

µg/kg micrograms per kilogram.

Italic Italicized result indicates analyte reported to the method detection limit.

Bold Bolded result indicates positively identified compound.

- Not analyzed.

B Analyte detected in an associated blank.

D Sample dilution required for analysis; reported values reflect the dilution.

H Sample holding time was exceeded, but the associated data are considered valid as reported.

J Data are estimated due to associated quality control data.

R Associated quality control did not meet acceptance criteria.

T Analyte was positively identified but the reported concentration is estimated; reported concentration is less than the reporting limit, but greater than the method detection limit.

UJ Potential low bias, possible false negative.

TABLE 2

SEMI-VOLATILE ORGANIC COMPOUNDS SOLID SAMPLE DATA SUMMARY
DEMONSTRATION TESTING AND FULL-SCALE OPERATION OF THE BIOGENESIS SEDIMENT DECONTAMINATION PROCESS
KEASBEY, NEW JERSEY
 (Page 97 of 108)

Field Sample Identification	MSL04-040107-0950	MSL05-040107-1000	MSL06-040107-1015	MSL07-040107-1025	MSL08-040107-1035	MSL09-040107-1045
Sediment Source	Lower Passaic River	Lower Passaic River	Lower Passaic River	Lower Passaic River	Lower Passaic River	Lower Passaic River
Location Identification	MSL	MSL	MSL	MSL	MSL	MSL
Date Collected	1/4/07	1/4/07	1/4/07	1/4/07	1/4/07	1/4/07
Matrix	Solid	Solid	Solid	Solid	Solid	Solid
Analyte/Methods (Units)						
Semi-Volatile Organic Compounds/SW8270C (µg/kg)						
1,2,4-Trichlorobenzene	-	-	-	-	-	-
1,2-Dichlorobenzene	-	-	-	-	-	-
1,2-Diphenylhydrazine	-	-	-	-	-	-
1,3-Dichlorobenzene	-	-	-	-	-	-
1,4-Dichlorobenzene	43 TD	45 TD	55 TD	<2100 D	<2100 D	61 TD
1,4-Dioxane (p-Dioxane)	-	-	-	-	-	-
2,3,4,6-Tetrachlorophenol	-	-	-	-	-	-
2,3,5,6-Tetrachlorophenol	-	-	-	-	-	-
2,4,5-Trichlorophenol	<2100 D	<2000 D	<2100 D	<2100 D	<2100 D	<2100 D
2,4,6-Trichlorophenol	<2100 D	<2000 D	<2100 D	<2100 D	<2100 D	<2100 D
2,4-Dichlorophenol	-	-	-	-	-	-
2,4-Dimethyl phenol	-	-	-	-	-	-
2,4-Dinitrophenol	-	-	-	-	-	-
2,4-Dinitrotoluene	<2100 D	<2000 D	<2100 D	<2100 D	<2100 D	<2100 D
2,6-Dichlorophenol	-	-	-	-	-	-
2,6-Dinitrotoluene	-	-	-	-	-	-
2-Aminonaphthalene	-	-	-	-	-	-
2-Chloronaphthalene	-	-	-	-	-	-
2-Chlorophenol	-	-	-	-	-	-
2-Methylnaphthalene	-	-	-	-	-	-
2-Methylphenol (o-Cresol)	<2100 D	<2000 D	<2100 D	<2100 D	<2100 D	<2100 D
2-Nitroaniline	-	-	-	-	-	-
2-Nitrophenol	-	-	-	-	-	-
3,3'-Dichlorobenzidine	-	-	-	-	-	-
3-Nitroaniline	-	-	-	-	-	-

TABLE 2

SEMI-VOLATILE ORGANIC COMPOUNDS SOLID SAMPLE DATA SUMMARY
DEMONSTRATION TESTING AND FULL-SCALE OPERATION OF THE BIOGENESIS SEDIMENT DECONTAMINATION PROCESS
KEASBEY, NEW JERSEY
 (Page 98 of 108)

Field Sample Identification	MSL04-040107-0950	MSL05-040107-1000	MSL06-040107-1015	MSL07-040107-1025	MSL08-040107-1035	MSL09-040107-1045
Sediment Source	Lower Passaic River	Lower Passaic River	Lower Passaic River	Lower Passaic River	Lower Passaic River	Lower Passaic River
Location Identification	MSL	MSL	MSL	MSL	MSL	MSL
Date Collected	1/4/07	1/4/07	1/4/07	1/4/07	1/4/07	1/4/07
Matrix	Solid	Solid	Solid	Solid	Solid	Solid
Analyte/Methods (Units)						
Semi-Volatile Organic Compounds/SW8270C (µg/kg) (continued)						
4,6-Dinitro-2-methylphenol	-	-	-	-	-	-
4-Bromophenyl phenyl ether	-	-	-	-	-	-
4-Chloro-3-methylphenol	-	-	-	-	-	-
4-Chloroaniline	-	-	-	-	-	-
4-Chlorophenyl phenyl ether	-	-	-	-	-	-
4-Methylphenol (p-Cresol)	-	-	-	-	-	-
4-Nitroaniline	-	-	-	-	-	-
4-Nitrophenol	-	-	-	-	-	-
Acenaphthene	63 TD	67 TD	94 TD	73 TD	69 TD	66 TD
Acenaphthylene	140 TD	200 TD	230 TD	170 TD	160 TD	260 TD
Acetophenone	-	-	-	-	-	-
Aniline	-	-	-	-	-	-
Anthracene	180 TD	190 TD	240 TD	180 TD	170 TD	220 TD
Atrazine	-	-	-	-	-	-
Benzaldehyde	-	-	-	-	-	-
Benzidine	-	-	-	-	-	-
Benzo(a)anthracene	420 TD	490 TD	550 TD	460 TD	420 TD	610 TD
Benzo(a)pyrene	370 TD	460 TD	480 TD	390 TD	360 TD	600 TD
Benzo(b)fluoranthene	380 TD	450 TD	470 TD	380 TD	350 TD	550 TD
Benzo(g,h,i)perylene	330 TD	400 TD	330 TD	230 TD	220 TD	350 TD
Benzo(k)fluoranthene	150 TD	220 TD	200 TD	180 TD	160 TD	250 TD
Benzoic acid	-	-	-	-	-	-
Benzyl alcohol	-	-	-	-	-	-
Benzyl butyl phthalate	-	-	-	-	-	-
Biphenyl (Diphenyl)	-	-	-	-	-	-

TABLE 2

SEMI-VOLATILE ORGANIC COMPOUNDS SOLID SAMPLE DATA SUMMARY
DEMONSTRATION TESTING AND FULL-SCALE OPERATION OF THE BIOGENESIS SEDIMENT DECONTAMINATION PROCESS
KEASBEY, NEW JERSEY
 (Page 99 of 108)

Field Sample Identification	MSL04-040107-0950	MSL05-040107-1000	MSL06-040107-1015	MSL07-040107-1025	MSL08-040107-1035	MSL09-040107-1045
Sediment Source	Lower Passaic River	Lower Passaic River	Lower Passaic River	Lower Passaic River	Lower Passaic River	Lower Passaic River
Location Identification	MSL	MSL	MSL	MSL	MSL	MSL
Date Collected	1/4/07	1/4/07	1/4/07	1/4/07	1/4/07	1/4/07
Matrix	Solid	Solid	Solid	Solid	Solid	Solid
Analyte/Methods (Units)						
Semi-Volatile Organic Compounds/SW8270C (µg/kg) (continued)						
bis(2-chloroethoxy) Methane	-	-	-	-	-	-
bis(2-chloroethyl) Ether	-	-	-	-	-	-
bis(2-chloroisopropyl) Ether	-	-	-	-	-	-
bis(2-ethylhexyl) Phthalate	-	-	-	-	-	-
Caprolactam	-	-	-	-	-	-
Carbazole	-	-	-	-	-	-
Chrysene	560 TD	650 TD	690 TD	590 TD	530 TD	810 TD
Cresols, m	<2100 D	<2000 D	<2100 D	<2100 D	<2100 D	<2100 D
Cresols, Total	-	-	-	-	-	-
Di-n-butyl phthalate	-	-	-	-	-	-
Di-n-octylphthalate	-	-	-	-	-	-
Dibenz(a,h)anthracene	<2100 D	<2000 D	<2100 D	<2100 D	<2100 D	<2100 D
Dibenzofuran	-	-	-	-	-	-
Diethyl Phthalate	-	-	-	-	-	-
Dimethyl phthalate	-	-	-	-	-	-
Fluoranthene	640 TD	770 TD	870 TD	790 TD	630 TD	1000 TD
Fluorene	89 TD	96 TD	110 TD	94 TD	92 TD	92 TD
Hexachlorobenzene	<2100 D	<2000 D	<2100 D	<2100 D	<2100 D	<2100 D
Hexachlorobutadiene	<2100 D	<2000 D	<2100 D	<2100 D	<2100 D	<2100 D
Hexachlorocyclopentadiene	-	-	-	-	-	-
Hexachloroethane	<2100 D	<2000 D	<2100 D	<2100 D	<2100 D	<2100 D
Indeno(1,2,3-c,d)Pyrene	250 TD	310 TD	300 TD	250 TD	200 TD	300 TD
Isophorone	-	-	-	-	-	-
n-Nitroso-di-n-propylamine	-	-	-	-	-	-
n-Nitrosodimethylamine	-	-	-	-	-	-

TABLE 2

SEMI-VOLATILE ORGANIC COMPOUNDS SOLID SAMPLE DATA SUMMARY
DEMONSTRATION TESTING AND FULL-SCALE OPERATION OF THE BIOGENESIS SEDIMENT DECONTAMINATION PROCESS
KEASBEY, NEW JERSEY
 (Page 100 of 108)

Field Sample Identification	MSL04-040107-0950	MSL05-040107-1000	MSL06-040107-1015	MSL07-040107-1025	MSL08-040107-1035	MSL09-040107-1045
Sediment Source	Lower Passaic River	Lower Passaic River	Lower Passaic River	Lower Passaic River	Lower Passaic River	Lower Passaic River
Location Identification	MSL	MSL	MSL	MSL	MSL	MSL
Date Collected	1/4/07	1/4/07	1/4/07	1/4/07	1/4/07	1/4/07
Matrix	Solid	Solid	Solid	Solid	Solid	Solid
Analyte/Methods (Units)						
Semi-Volatile Organic Compounds/SW8270C (µg/kg) (continued)						
n-Nitrosodiphenylamine	-	-	-	-	-	-
Naphthalene	84 TD	93 TD	110 TD	83 TD	75 TD	94 TD
Nitrobenzene	<2100 D	<2000 D	<2100 D	<2100 D	<2100 D	<2100 D
Pentachlorophenol	<10000 D	<9800 D	<10000 D	<10000 D	<10000 D	<10000 D
Phenanthrene	-	-	-	-	-	-
Phenol	-	-	-	-	-	-
Pyrene	670 TD	740 TD	850 TD	690 TD	630 TD	860 TD
Pyridine	-	-	-	-	-	-

µg/kg micrograms per kilogram.

Italic Italicized result indicates analyte reported to the method detection limit.

Bold Bolded result indicates positively identified compound.

- Not analyzed.

B Analyte detected in an associated blank.

D Sample dilution required for analysis; reported values reflect the dilution.

H Sample holding time was exceeded, but the associated data are considered valid as reported.

J Data are estimated due to associated quality control data.

R Associated quality control did not meet acceptance criteria.

T Analyte was positively identified but the reported concentration is estimated; reported concentration is less than the reporting limit, but greater than the method detection limit.

UJ Potential low bias, possible false negative.

TABLE 2

SEMI-VOLATILE ORGANIC COMPOUNDS SOLID SAMPLE DATA SUMMARY
DEMONSTRATION TESTING AND FULL-SCALE OPERATION OF THE BIOGENESIS SEDIMENT DECONTAMINATION PROCESS
KEASBEY, NEW JERSEY
 (Page 101 of 108)

Field Sample Identification	MSL10-040107-1055	MSL11-040107-1055	PR-A-040107-0905	PR-B-040107-0940	PR-C-040107-1035	PR-D-040107-1055
Sediment Source	Lower Passaic River	Lower Passaic River	Lower Passaic River	Lower Passaic River	Lower Passaic River	Lower Passaic River
Location Identification	MSL	MSL	MSL	MSL	MSL	MSL
Date Collected	1/4/07	1/4/07	1/4/07	1/4/07	1/4/07	1/4/07
Matrix	Solid	Solid	Solid	Solid	Solid	Solid
Analyte/Methods (Units)						
Semi-Volatile Organic Compounds/SW8270C (µg/kg)						
1,2,4-Trichlorobenzene	-	-	-	-	-	-
1,2-Dichlorobenzene	-	-	-	-	-	-
1,2-Diphenylhydrazine	-	-	-	-	-	-
1,3-Dichlorobenzene	-	-	-	-	-	-
1,4-Dichlorobenzene	<2100 D	<2100 D	-	-	-	-
1,4-Dioxane (p-Dioxane)	-	-	-	-	-	-
2,3,4,6-Tetrachlorophenol	-	-	-	-	-	-
2,3,5,6-Tetrachlorophenol	-	-	-	-	-	-
2,4,5-Trichlorophenol	<2100 D	<2100 D	<1000 D	<1000 D	<1100 D	<1100 D
2,4,6-Trichlorophenol	<2100 D	<2100 D	<1000 D	<1000 D	<1100 D	<1100 D
2,4-Dichlorophenol	-	-	<1000 D	<1000 D	<1100 D	<1100 D
2,4-Dimethyl phenol	-	-	<1000 D	<1000 D	<1100 D	<1100 D
2,4-Dinitrophenol	-	-	<5000 D	<5000 D	<5100 D	<5200 D
2,4-Dinitrotoluene	<2100 D	<2100 D	<1000 D	<1000 D	<1100 D	<1100 D
2,6-Dichlorophenol	-	-	-	-	-	-
2,6-Dinitrotoluene	-	-	<1000 D	<1000 D	<1100 D	<1100 D
2-Aminonaphthalene	-	-	-	-	-	-
2-Chloronaphthalene	-	-	<1000 D	<1000 D	<1100 D	<1100 D
2-Chlorophenol	-	-	<1000 D	<1000 D	<1100 D	<1100 D
2-Methylnaphthalene	-	-	90 TD	100 TD	92 TD	110 TD
2-Methylphenol (o-Cresol)	<2100 D	<2100 D	<1000 D	<1000 D	<1100 D	<1100 D
2-Nitroaniline	-	-	<5000 D	<5000 D	<5100 D	<5200 D
2-Nitrophenol	-	-	<1000 D	<1000 D	<1100 D	<1100 D
3,3'-Dichlorobenzidine	-	-	<15000 D	<5000 D	<5100 D	<5200 D
3-Nitroaniline	-	-	<5000 D	<5000 D	<5100 D	<5200 D

TABLE 2

SEMI-VOLATILE ORGANIC COMPOUNDS SOLID SAMPLE DATA SUMMARY
DEMONSTRATION TESTING AND FULL-SCALE OPERATION OF THE BIOGENESIS SEDIMENT DECONTAMINATION PROCESS
KEASBEY, NEW JERSEY
 (Page 102 of 108)

Field Sample Identification	MSL10-040107-1055	MSL11-040107-1055	PR-A-040107-0905	PR-B-040107-0940	PR-C-040107-1035	PR-D-040107-1055
Sediment Source	Lower Passaic River	Lower Passaic River	Lower Passaic River	Lower Passaic River	Lower Passaic River	Lower Passaic River
Location Identification	MSL	MSL	MSL	MSL	MSL	MSL
Date Collected	1/4/07	1/4/07	1/4/07	1/4/07	1/4/07	1/4/07
Matrix	Solid	Solid	Solid	Solid	Solid	Solid
Analyte/Methods (Units)						
Semi-Volatile Organic Compounds/SW8270C (µg/kg) (continued)						
4,6-Dinitro-2-methylphenol	-	-	<5000 D	<5000 D	<5100 D	<5200 D
4-Bromophenyl phenyl ether	-	-	<1000 D	<1000 D	<1100 D	<1100 D
4-Chloro-3-methylphenol	-	-	<1000 D	<1000 D	<1100 D	<1100 D
4-Chloroaniline	-	-	170 TD	170 TD	120 TD	170 TD
4-Chlorophenyl phenyl ether	-	-	<1000 D	<1000 D	<1100 D	<1100 D
4-Methylphenol (p-Cresol)	-	-	100 TD	130 TD	98 TD	140 TD
4-Nitroaniline	-	-	<5000 D	<5000 D	<5100 D	<5200 D
4-Nitrophenol	-	-	<5000 D	<5000 D	<5100 D	65 TD
Acenaphthene	61 TD	61 TD	110 TD	110 TD	100 TD	130 TD
Acenaphthylene	150 TD	170 TD	380 TD	320 TD	260 TD	270 TD
Acetophenone	-	-	<1000 D	<1000 D	<1100 D	<1100 D
Aniline	-	-	-	-	-	-
Anthracene	130 TD	150 TD	370 TD	330 TD	280 TD	350 TD
Atrazine	-	-	<1000 D	<1000 D	<1100 D	<1100 D
Benzaldehyde	-	-	<1000 D	<1000 D	<1100 D	<1100 D
Benzidine	-	-	-	-	-	-
Benzo(a)anthracene	360 TD	400 TD	1100 D	810 TD	590 TD	790 TD
Benzo(a)pyrene	300 TD	370 TD	1000 D	880 TD	630 TD	830 TD
Benzo(b)fluoranthene	290 TD	360 TD	1200 D	1000 D	800 TD	1000 TD
Benzo(g,h,i)perylene	150 TD	200 TD	280 TD	230 TD	200 TD	270 TD
Benzo(k)fluoranthene	140 TD	160 TD	500 TD	480 TD	300 TD	420 TD
Benzoic acid	-	-	-	-	-	-
Benzyl alcohol	-	-	<1000 D	<1000 D	<1100 D	<1100 D
Benzyl butyl phthalate	-	-	92 TD	95 TD	87 TD	100 TD
Biphenyl (Diphenyl)	-	-	<1000 D	<1000 D	<1100 D	<1100 D

TABLE 2

SEMI-VOLATILE ORGANIC COMPOUNDS SOLID SAMPLE DATA SUMMARY
DEMONSTRATION TESTING AND FULL-SCALE OPERATION OF THE BIOGENESIS SEDIMENT DECONTAMINATION PROCESS
KEASBEY, NEW JERSEY
 (Page 103 of 108)

Field Sample Identification	MSL10-040107-1055	MSL11-040107-1055	PR-A-040107-0905	PR-B-040107-0940	PR-C-040107-1035	PR-D-040107-1055
Sediment Source	Lower Passaic River	Lower Passaic River	Lower Passaic River	Lower Passaic River	Lower Passaic River	Lower Passaic River
Location Identification	MSL	MSL	MSL	MSL	MSL	MSL
Date Collected	1/4/07	1/4/07	1/4/07	1/4/07	1/4/07	1/4/07
Matrix	Solid	Solid	Solid	Solid	Solid	Solid
Analyte/Methods (Units)						
Semi-Volatile Organic Compounds/SW8270C (µg/kg) (continued)						
bis(2-chloroethoxy) Methane	-	-	<1000 D	<1000 D	<1100 D	<1100 D
bis(2-chloroethyl) Ether	-	-	<1000 D	<1000 D	<1100 D	<1100 D
bis(2-chloroisopropyl) Ether	-	-	<1000 D	<1000 D	<1100 D	<1100 D
bis(2-ethylhexyl) Phthalate	-	-	15000 D	16000 D	12000 D	17000 D
Caprolactam	-	-	<1000 D	<1000 D	<1100 D	<1100 D
Carbazole	-	-	80 TD	89 TD	61 TD	81 TD
Chrysene	450 TD	520 TD	1200 D	990 TD	720 TD	1000 TD
Cresols, m	<2100 D	<2100 D	-	-	-	-
Cresols, Total	-	-	-	-	-	-
Di-n-butyl phthalate	-	-	<1000 D	<1000 D	<1100 D	<1100 D
Di-n-octylphthalate	-	-	120 TD	160 TD	77 TD	180 TD
Dibenz(a,h)anthracene	<2100 D	<2100 D	85 TD	67 TD	59 TD	70 TD
Dibenzofuran	-	-	89 TD	87 TD	74 TD	92 TD
Diethyl Phthalate	-	-	<1000 D	<1000 D	<1100 D	<1100 D
Dimethyl phthalate	-	-	<1000 D	<1000 D	<1100 D	<1100 D
Fluoranthene	620 TD	600 TD	1700 D	1900 D	1300 D	1800 D
Fluorene	58 TD	72 TD	140 TD	150 TD	120 TD	160 TD
Hexachlorobenzene	<2100 D	<2100 D	<1000 D	<1000 D	<1100 D	<1100 D
Hexachlorobutadiene	<2100 D	<2100 D	<1000 D	<1000 D	<1100 D	<1100 D
Hexachlorocyclopentadiene	-	-	<5000 DR	<5000 D	<5100 D	<5200 D
Hexachloroethane	<2100 D	<2100 D	<1000 D	<1000 D	<1100 D	<1100 D
Indeno(1,2,3-c,d)Pyrene	150 TD	180 TD	320 TD	250 TD	220 TD	260 TD
Isophorone	-	-	<1000 D	<1000 D	<1100 D	<1100 D
n-Nitroso-di-n-propylamine	-	-	<1000 D	<1000 D	<1100 D	<1100 D
n-Nitrosodimethylamine	-	-	-	-	-	-

TABLE 2

SEMI-VOLATILE ORGANIC COMPOUNDS SOLID SAMPLE DATA SUMMARY
DEMONSTRATION TESTING AND FULL-SCALE OPERATION OF THE BIOGENESIS SEDIMENT DECONTAMINATION PROCESS
KEASBEY, NEW JERSEY
 (Page 104 of 108)

Field Sample Identification	MSL10-040107-1055	MSL11-040107-1055	PR-A-040107-0905	PR-B-040107-0940	PR-C-040107-1035	PR-D-040107-1055
Sediment Source	Lower Passaic River	Lower Passaic River	Lower Passaic River	Lower Passaic River	Lower Passaic River	Lower Passaic River
Location Identification	MSL	MSL	MSL	MSL	MSL	MSL
Date Collected	1/4/07	1/4/07	1/4/07	1/4/07	1/4/07	1/4/07
Matrix	Solid	Solid	Solid	Solid	Solid	Solid
Analyte/Methods (Units)						
Semi-Volatile Organic Compounds/SW8270C (µg/kg) (continued)						
n-Nitrosodiphenylamine	-	-	<1000 D	<1000 D	<1100 D	<1100 D
Naphthalene	69 TD	63 TD	160 TD	160 TD	140 TD	160 TD
Nitrobenzene	<2100 D	<2100 D	<1000 D	<1000 D	<1100 D	<1100 D
Pentachlorophenol	<10000 D	<10000 D	<5000 D	<5000 D	<5100 D	<5200 D
Phenanthrene	-	-	760 TD	850 TD	660 TD	880 TD
Phenol	-	-	<1000 D	32 TD	25 TD	38 TD
Pyrene	460 TD	570 TD	1200 D	1300 D	1000 TD	1400 D
Pyridine	-	-	-	-	-	-

µg/kg micrograms per kilogram.

Italic Italicized result indicates analyte reported to the method detection limit.

Bold Bolded result indicates positively identified compound.

- Not analyzed.

B Analyte detected in an associated blank.

D Sample dilution required for analysis; reported values reflect the dilution.

H Sample holding time was exceeded, but the associated data are considered valid as reported.

J Data are estimated due to associated quality control data.

R Associated quality control did not meet acceptance criteria.

T Analyte was positively identified but the reported concentration is estimated; reported concentration is less than the reporting limit, but greater than the method detection limit.

UJ Potential low bias, possible false negative.

TABLE 2

SEMI-VOLATILE ORGANIC COMPOUNDS SOLID SAMPLE DATA SUMMARY
DEMONSTRATION TESTING AND FULL-SCALE OPERATION OF THE BIOGENESIS SEDIMENT DECONTAMINATION PROCESS
KEASBEY, NEW JERSEY
 (Page 105 of 108)

Field Sample Identification	TS1-121908-0800	AD1-121908-0830	AD2-121908-0820	AD3-121908-0840	MS1-121908-0850
Sediment Source	Lower Passaic River	None	None	None	Lower Passaic River
Location Identification	TS	AD	AD	AD	MSL
Date Collected	12/19/08	12/19/08	12/19/08	12/19/08	12/19/08
Matrix	Solid	Solid	Solid	Solid	Solid
Analyte/Methods (Units)					
Semi-Volatile Organic Compounds/SW8270C (µg/kg)					
1,2,4-Trichlorobenzene	-	-	-	-	-
1,2-Dichlorobenzene	-	-	-	-	-
1,2-Diphenylhydrazine	-	-	-	-	-
1,3-Dichlorobenzene	-	-	-	-	-
1,4-Dichlorobenzene	37 TD	1.9 T	3.5	<49 D	7.3 TD
1,4-Dioxane (p-Dioxane)	-	-	-	-	-
2,3,4,6-Tetrachlorophenol	-	-	-	-	-
2,3,5,6-Tetrachlorophenol	-	-	-	-	-
2,4,5-Trichlorophenol	<430 D	<17	<17	<240 D	<110 D
2,4,6-Trichlorophenol	<430 D	<17	<17	<240 D	<110 D
2,4-Dichlorophenol	-	-	-	-	-
2,4-Dimethyl phenol	-	-	-	-	-
2,4-Dinitrophenol	-	-	-	-	-
2,4-Dinitrotoluene	<430 D	<17	<17	<240 D	<110 D
2,6-Dichlorophenol	-	-	-	-	-
2,6-Dinitrotoluene	-	-	-	-	-
2-Aminonaphthalene	-	-	-	-	-
2-Chloronaphthalene	-	-	-	-	-
2-Chlorophenol	-	-	-	-	-
2-Methylnaphthalene	-	-	-	-	-
2-Methylphenol (o-Cresol)	<430 D	2.7 T	1.9 T	<240 D	<110 D
2-Nitroaniline	-	-	-	-	-
2-Nitrophenol	-	-	-	-	-
3,3'-Dichlorobenzidine	-	-	-	-	-
3-Nitroaniline	-	-	-	-	-

TABLE 2

SEMI-VOLATILE ORGANIC COMPOUNDS SOLID SAMPLE DATA SUMMARY
DEMONSTRATION TESTING AND FULL-SCALE OPERATION OF THE BIOGENESIS SEDIMENT DECONTAMINATION PROCESS
KEASBEY, NEW JERSEY
 (Page 106 of 108)

Field Sample Identification	TS1-121908-0800	AD1-121908-0830	AD2-121908-0820	AD3-121908-0840	MS1-121908-0850
Sediment Source	Lower Passaic River	None	None	None	Lower Passaic River
Location Identification	TS	AD	AD	AD	MSL
Date Collected	12/19/08	12/19/08	12/19/08	12/19/08	12/19/08
Matrix	Solid	Solid	Solid	Solid	Solid
Analyte/Methods (Units)					
Semi-Volatile Organic Compounds/SW8270C (µg/kg) (continued)					
4,6-Dinitro-2-methylphenol	-	-	-	-	-
4-Bromophenyl phenyl ether	-	-	-	-	-
4-Chloro-3-methylphenol	-	-	-	-	-
4-Chloroaniline	-	-	-	-	-
4-Chlorophenyl phenyl ether	-	-	-	-	-
4-Methylphenol (p-Cresol)	<430 D	<17	<17	<240 D	<110 D
4-Nitroaniline	-	-	-	-	-
4-Nitrophenol	-	-	-	-	-
Acenaphthene	36 TD	<3.5	<3.5	<49 D	7.1 TD
Acenaphthylene	180 D	<3.5	<3.5	<49 D	29 D
Acetophenone	-	-	-	-	-
Aniline	-	-	-	-	-
Anthracene	170 TD	<17	<17	<240 D	23 TD
Atrazine	-	-	-	-	-
Benzaldehyde	-	-	-	-	-
Benzydine	-	-	-	-	-
Benzo(a)anthracene	620 D	<3.5	<3.5	<49 D	82 D
Benzo(a)pyrene	600 D	<3.5	<3.5	<49 D	81 D
Benzo(b)fluoranthene	720 D	<3.5	<3.5	<49 D	100 D
Benzo(g,h,i)perylene	540 D	<3.5	<3.5	<49 D	62 D
Benzo(k)fluoranthene	390 D	<3.5	<3.5	<49 D	53 D
Benzoic acid	-	-	-	-	-
Benzyl alcohol	-	-	-	-	-
Benzyl butyl phthalate	-	-	-	-	-
Biphenyl (Diphenyl)	-	-	-	-	-

TABLE 2
SEMI-VOLATILE ORGANIC COMPOUNDS SOLID SAMPLE DATA SUMMARY
DEMONSTRATION TESTING AND FULL-SCALE OPERATION OF THE BIOGENESIS SEDIMENT DECONTAMINATION PROCESS
KEASBEY, NEW JERSEY
(Page 107 of 108)

Field Sample Identification	TS1-121908-0800	AD1-121908-0830	AD2-121908-0820	AD3-121908-0840	MS1-121908-0850
Sediment Source	Lower Passaic River	None	None	None	Lower Passaic River
Location Identification	TS	AD	AD	AD	MSL
Date Collected	12/19/08	12/19/08	12/19/08	12/19/08	12/19/08
Matrix	Solid	Solid	Solid	Solid	Solid
Analyte/Methods (Units)					
Semi-Volatile Organic Compounds/SW8270C (µg/kg) (continued)					
bis(2-chloroethoxy) Methane	-	-	-	-	-
bis(2-chloroethyl) Ether	-	-	-	-	-
bis(2-chloroisopropyl) Ether	-	-	-	-	-
bis(2-ethylhexyl) Phthalate	-	-	-	-	-
Caprolactam	-	-	-	-	-
Carbazole	-	-	-	-	-
Chrysene	610 D	<3.5	<3.5	<49 D	<21 D
Cresols, m	-	-	-	-	-
Cresols, Total	-	-	-	-	-
Di-n-butyl phthalate	-	-	-	-	-
Di-n-octylphthalate	-	-	-	-	-
Dibenz(a,h)anthracene	85 TD	<3.5	<3.5	<49 D	<21 D
Dibenzofuran	-	-	-	-	-
Diethyl Phthalate	-	-	-	-	-
Dimethyl phthalate	-	-	-	-	-
Fluoranthene	880 D	<3.5	0.62 T	<49 D	130 D
Fluorene	150 D	4.2	4.2	<49 D	36 D
Hexachlorobenzene	<87 D	<3.5	<3.5	<49 D	<21 D
Hexachlorobutadiene	<87 D	<3.5	<3.5	<49 D	<21 D
Hexachlorocyclopentadiene	-	-	-	-	-
Hexachloroethane	<430 D	<17	<17	<240 D	<110 D
Indeno(1,2,3-c,d)Pyrene	470 D	<3.5	<3.5	<49 D	51 D
Isophorone	-	-	-	-	-
n-Nitroso-di-n-propylamine	-	-	-	-	-
n-Nitrosodimethylamine	-	-	-	-	-

TABLE 2
SEMI-VOLATILE ORGANIC COMPOUNDS SOLID SAMPLE DATA SUMMARY
DEMONSTRATION TESTING AND FULL-SCALE OPERATION OF THE BIOGENESIS SEDIMENT DECONTAMINATION PROCESS
KEASBEY, NEW JERSEY
(Page 108 of 108)

Field Sample Identification	TS1-121908-0800	AD1-121908-0830	AD2-121908-0820	AD3-121908-0840	MS1-121908-0850
Sediment Source	Lower Passaic River	None	None	None	Lower Passaic River
Location Identification	TS	AD	AD	AD	MSL
Date Collected	12/19/08	12/19/08	12/19/08	12/19/08	12/19/08
Matrix	Solid	Solid	Solid	Solid	Solid
Analyte/Methods (Units)					
Semi-Volatile Organic Compounds/SW8270C (µg/kg) (continued)					
n-Nitrosodiphenylamine	-	-	-	-	-
Naphthalene	120 D	<3.5	<3.5	<49 D	19 TD
Nitrobenzene	<87 D	<3.5	<3.5	<49 D	<21 D
Pentachlorophenol	<430 D	<17	<17	<240 D	<110 D
Phenanthrene	390 D	1.3 T	1.4 T	<49 D	68 D
Phenol	-	-	-	-	-
Pyrene	710 D	<3.5	<3.5	<49 D	98 D
Pyridine	-	-	-	-	-

- µg/kg micrograms per kilogram.
- Italic* Italicized result indicates analyte reported to the method detection limit.
- Bold** Bolded result indicates positively identified compound.
- Not analyzed.
- B Analyte detected in an associated blank.
- D Sample dilution required for analysis; reported values reflect the dilution.
- H Sample holding time was exceeded, but the associated data are considered valid as reported.
- J Data are estimated due to associated quality control data.
- R Associated quality control did not meet acceptance criteria.
- T Analyte was positively identified but the reported concentration is estimated; reported concentration is less than the reporting limit, but greater than the method detection limit.
- UJ Potential low bias, possible false negative.

TABLE 3

POLYNUCLEAR AROMATIC HYDROCARBONS SOLID SAMPLE DATA SUMMARY
DEMONSTRATION TESTING AND FULL-SCALE OPERATION OF THE BIOGENESIS SEDIMENT DECONTAMINATION PROCESS
KEASBEY, NEW JERSEY
 (Page 1 of 67)

Field Sample Identification	RS-211205-1000	TS-211205-1715	WS1-211205-1800	TS-291205-1100	WS-291205-1110	RS-030106-1600	TS-030106-1645
Sediment Source	Raritan River	Raritan River	Raritan River	Raritan River	Raritan River	Raritan River	Raritan River
Location Identification	RS	TS	WS	TS	WS	RS	TS
Date Collected	12/21/05	12/21/05	12/21/05	12/29/05	12/29/05	1/3/06	1/3/06
Matrix	Solid	Solid	Solid	Solid	Solid	Solid	Solid
Analyte/Methods (Units)							
Polynuclear Aromatic Hydrocarbons/SW8270C-SIM (µg/kg)							
Acenaphthene	45	51	60 D	30	6.7 T	31	38
Acenaphthylene	60	68	99 D	60	8.7 T	50	54
Anthracene	190	190	290 D	130	20 T	91	160
Benzo(a)anthracene	340	430	310 D	260	26	200	340
Benzo(a)pyrene	320	530	290 D	330	24	240	400
Benzo(b)fluoranthene	470	600	470 D	330	30	280	420
Benzo(g,h,i)perylene	210	300	210 D	160	17 T	140	200
Benzo(k)fluoranthene	<18	210	<43 D	160	11 T	110	170
Chrysene	340	440	320 D	280	30	220	370
Dibenz(a,h)anthracene	54	79	53 D	40	<21	33	50
Fluoranthene	510	640	710 D	500	51	360	630
Fluorene	80	80	120 D	43	12 T	39	51
Indeno(1,2,3-c,d)Pyrene	180	260	170 D	140	12 T	120	180
Naphthalene	100	140	120 D	28	11 T	56	56
Phenanthrene	400	420 J	580 D	300	46	160	420
Pyrene	550	680	620 D	490 J	66 J	380 J	570 J

µg/kg micrograms per kilogram

Bold Bolded result indicates positively identified compound.

B Analyte detected in an associated blank.

D Sample dilution required for analysis; reported values reflect the dilution.

J Data are estimated due to associated quality control data.

T Analyte was positively identified but the reported concentration is estimated; reported concentration is less than the reporting limit, but greater than the method detection limit.

UJ Potential low bias, possible false negative.

SIM Selective ion monitoring

- Not analyzed

TABLE 3

POLYNUCLEAR AROMATIC HYDROCARBONS SOLID SAMPLE DATA SUMMARY
DEMONSTRATION TESTING AND FULL-SCALE OPERATION OF THE BIOGENESIS SEDIMENT DECONTAMINATION PROCESS
KEASBEY, NEW JERSEY
 (Page 2 of 67)

Field Sample Identification	WS1-030106-1615	WS2-030106-1630	RS-040106-1300	TS-040106-1100	WS-040106-1400	RS-050106-1500	TS-050106-1505
Sediment Source	Raritan River	Raritan River	Raritan River	Raritan River	Raritan River	Raritan River	Raritan River
Location Identification	WS1	WS2	RS	TS	WS	RS	TS
Date Collected	1/3/06	1/3/06	1/4/06	1/4/06	1/4/06	1/5/06	1/5/06
Matrix	Solid	Solid	Solid	Solid	Solid	Solid	Solid
Analyte/Methods (Units)							
Polynuclear Aromatic Hydrocarbons/SW8270C-SIM (µg/kg)							
Acenaphthene	25	20	27 T	12	11 T	74	53
Acenaphthylene	37	26	54	22	20 T	86	48
Anthracene	89	59	94	46	38	230	150
Benzo(a)anthracene	130	67	230	100	56	570	250
Benzo(a)pyrene	110	61	270	120	53	680	290
Benzo(b)fluoranthene	130	71	280	130	61	980	310
Benzo(g,h,i)perylene	71	37	160	66	33	330	140
Benzo(k)fluoranthene	64	29	130	56	27	<21	140
Chrysene	120	63	220	110	58	520	260
Dibenz(a,h)anthracene	19 T	8.1 T	37	16	8.1 T	83	37
Fluoranthene	270	160	330	180	110	980	400
Fluorene	42	31	38	17	18 T	110	66
Indeno(1,2,3-c,d)Pyrene	57	28	130	57	26	300	120
Naphthalene	45	34	62	27	19 T	120	120
Phenanthrene	160	150	180	96	63	830	430
Pyrene	280 J	170 J	390 J	200 J	130 J	1000 J	490 J

µg/kg micrograms per kilogram

Bold Bolded result indicates positively identified compound.

B Analyte detected in an associated blank.

D Sample dilution required for analysis; reported values reflect the dilution.

J Data are estimated due to associated quality control data.

T Analyte was positively identified but the reported concentration is estimated; reported concentration is less than the reporting limit, but greater than the method detection limit.

UJ Potential low bias, possible false negative.

SIM Selective ion monitoring

- Not analyzed

TABLE 3

POLYNUCLEAR AROMATIC HYDROCARBONS SOLID SAMPLE DATA SUMMARY
DEMONSTRATION TESTING AND FULL-SCALE OPERATION OF THE BIOGENESIS SEDIMENT DECONTAMINATION PROCESS
KEASBEY, NEW JERSEY
 (Page 3 of 67)

Field Sample Identification	WS-050106-1510	RS-060106-1531	TS-060106-1532	WS-060106-1533	RS-090106-1500	RS-090106-1500	TS-090106-1501
Sediment Source	Raritan River	Raritan River	Raritan River	Raritan River	Raritan River	Raritan River	Raritan River
Location Identification	WS	RS	TS	WS	RS	RS	TS
Date Collected	1/5/06	1/6/06	1/6/06	1/6/06	1/9/06	1/9/06	1/9/06
Matrix	Solid	Solid	Solid	Solid	Solid	Solid	Solid
Analyte/Methods (Units)							
Polynuclear Aromatic Hydrocarbons/SW8270C-SIM (µg/kg)							
Acenaphthene	9.6 T	<82	26	7.2 T	41	41	24 TD
Acenaphthylene	16 T	37 T	67	11 T	66	66	63 D
Anthracene	32	66 T	130	22	150	150	97 D
Benzo(a)anthracene	51	120	250	36	300	300	240 D
Benzo(a)pyrene	46	130	330	33	350	350	290 D
Benzo(b)fluoranthene	80	150	350	44	390	390	300 D
Benzo(g,h,i)perylene	31	92	170	22	180	180	180 D
Benzo(k)fluoranthene	<19	62 T	140	15 T	140	140	110 D
Chrysene	48	110	260	35	310	310	230 D
Dibenz(a,h)anthracene	7.7 T	20 T	40	5.3 T	47	47	39 TD
Fluoranthene	84	160	430	62	480	480	340 D
Fluorene	15 T	28 T	38	12 T	57	57	34 TD
Indeno(1,2,3-c,d)Pyrene	26	69 T	140	17 T	170	170	140 D
Naphthalene	20	39 T	49	12 T	82	82	69 D
Phenanthrene	52	110	210	38	270	270	170 D
Pyrene	110 J	230 J	460 J	84 J	630	630 J	460 D

µg/kg micrograms per kilogram

Bold Bolded result indicates positively identified compound.

B Analyte detected in an associated blank.

D Sample dilution required for analysis; reported values reflect the dilution.

J Data are estimated due to associated quality control data.

T Analyte was positively identified but the reported concentration is estimated; reported concentration is less than the reporting limit, but greater than the method detection limit.

UJ Potential low bias, possible false negative.

SIM Selective ion monitoring

- Not analyzed

TABLE 3

POLYNUCLEAR AROMATIC HYDROCARBONS SOLID SAMPLE DATA SUMMARY
DEMONSTRATION TESTING AND FULL-SCALE OPERATION OF THE BIOGENESIS SEDIMENT DECONTAMINATION PROCESS
KEASBEY, NEW JERSEY
 (Page 4 of 67)

Field Sample Identification	TS-090106-1501	WS-090106-1502	WS-090106-1502	RS-100106-1600	TS-100106-1601	TS-100106-1601	TS-100106-1601
Sediment Source	Raritan River	Raritan River	Raritan River	Raritan River	Raritan River	Raritan River	Raritan River
Location Identification	TS	WS	WS	RS	TS	TS	TS
Date Collected	1/9/06	1/9/06	1/9/06	1/10/06	1/10/06	1/10/06	1/10/06
Matrix	Solid	Solid	Solid	Solid	Solid	Solid	Solid
Analyte/Methods (Units)							
Polynuclear Aromatic Hydrocarbons/SW8270C-SIM (µg/kg)							
Acenaphthene	24 TD	11 T	11 T	37	240 D	270	270
Acenaphthylene	63 D	25	25	78	180 D	150	150
Anthracene	97 D	44	44	140	550 D	650	650
Benzo(a)anthracene	240 D	70	70	450	1500 D	1600	1600
Benzo(a)pyrene	290 D	65	65	480	1400 D	1800	1800
Benzo(b)fluoranthene	300 D	82	82	520	1500 D	1900	1900
Benzo(g,h,i)perylene	180 D	38	38	270	910 D	1000	1000
Benzo(k)fluoranthene	110 D	32	32	210	620 D	860	860
Chrysene	230 D	70	70	440	1600 D	1800	1800
Dibenz(a,h)anthracene	39 TD	9.5 T	9.5 T	61	220 D	270	270
Fluoranthene	340 D	130	130	530	2200 D	3000	3000
Fluorene	34 TD	17 T	17 T	60	230 D	240	240
Indeno(1,2,3-c,d)Pyrene	140 D	32	32	220	820 D	950	950
Naphthalene	69 D	27	27	95	210 D	230	230
Phenanthrene	170 D	61	61	260	1500 D	1900	1900
Pyrene	460 DJ	150	150 J	850	2500 D	2500	2500

µg/kg micrograms per kilogram

Bold Bolded result indicates positively identified compound.

B Analyte detected in an associated blank.

D Sample dilution required for analysis; reported values reflect the dilution.

J Data are estimated due to associated quality control data.

T Analyte was positively identified but the reported concentration is estimated; reported concentration is less than the reporting limit, but greater than the method detection limit.

UJ Potential low bias, possible false negative.

SIM Selective ion monitoring

- Not analyzed

TABLE 3

POLYNUCLEAR AROMATIC HYDROCARBONS SOLID SAMPLE DATA SUMMARY
DEMONSTRATION TESTING AND FULL-SCALE OPERATION OF THE BIOGENESIS SEDIMENT DECONTAMINATION PROCESS
KEASBEY, NEW JERSEY
 (Page 5 of 67)

Field Sample Identification	WS-100106-1602	RS-110106-1630	TS-110106-1631	TS-110106-1631	TS-110106-1631	TS-110106-1631	RS-120106-1630
Sediment Source	Raritan River	Raritan River	Raritan River	Raritan River	Raritan River	Raritan River	Raritan River
Location Identification	WS	RS	TS	TS	TS	TS	RS
Date Collected	1/10/06	1/11/06	1/11/06	1/11/06	1/11/06	1/11/06	1/12/06
Matrix	Solid	Solid	Solid	Solid	Solid	Solid	Solid
Analyte/Methods (Units)							
Polynuclear Aromatic Hydrocarbons/SW8270C-SIM (µg/kg)							
Acenaphthene	20	32	330 D	340	340	-	33
Acenaphthylene	40	62	130 D	-	110	-	70
Anthracene	75	120	490 D	530	530	-	110
Benzo(a)anthracene	140	320	1100 D	1000	1000	-	300
Benzo(a)pyrene	150	350	1000 D	1200	1200	-	330
Benzo(b)fluoranthene	160	360	1200 D	-	1400	1200 D	370
Benzo(g,h,i)perylene	100	220	600 D	620	620	-	170
Benzo(k)fluoranthene	66	130	450 D	610	610	-	130
Chrysene	140	330	1100 D	-	1100	-	330
Dibenz(a,h)anthracene	24	49	160 D	170	170	-	40
Fluoranthene	240	410	2100 D	-	2200	2100 D	430
Fluorene	27	45	300 D	260	260	-	48
Indeno(1,2,3-c,d)Pyrene	85	190	570 D	610	610	-	140
Naphthalene	47	77	120 D	110	110	-	60
Phenanthrene	110	200	1500 D	-	1600	1500 D	190
Pyrene	240	620	2200 D	-	1900	2200 D	610 J

µg/kg micrograms per kilogram

Bold Bolded result indicates positively identified compound.

B Analyte detected in an associated blank.

D Sample dilution required for analysis; reported values reflect the dilution.

J Data are estimated due to associated quality control data.

T Analyte was positively identified but the reported concentration is estimated; reported concentration is less than the reporting limit, but greater than the method detection limit.

UJ Potential low bias, possible false negative.

SIM Selective ion monitoring

- Not analyzed

TABLE 3

POLYNUCLEAR AROMATIC HYDROCARBONS SOLID SAMPLE DATA SUMMARY
DEMONSTRATION TESTING AND FULL-SCALE OPERATION OF THE BIOGENESIS SEDIMENT DECONTAMINATION PROCESS
KEASBEY, NEW JERSEY
 (Page 6 of 67)

Field Sample Identification	RS-120106-1630	TS-120106-1601	TS-120106-1601	WS-120106-1602	WS-120106-1602	RS-190106-1600	TS-190106-1601
Sediment Source	Raritan River	Raritan River	Raritan River	Raritan River	Raritan River	Lower Passaic River	Lower Passaic River
Location Identification	RS	TS	TS	WS	WS	RS	TS
Date Collected	1/12/06	1/12/06	1/12/06	1/12/06	1/12/06	1/19/06	1/19/06
Matrix	Solid	Solid	Solid	Solid	Solid	Solid	Solid
Analyte/Methods (Units)							
Polynuclear Aromatic Hydrocarbons/SW8270C-SIM (µg/kg)							
Acenaphthene	33	290 D	290 D	23	23	400 D	410 D
Acenaphthylene	70	180 D	180 D	48	48	660 D	720 D
Anthracene	110	510 D	510 D	94	94	1200 D	1200 D
Benzo(a)anthracene	300	1600 D	1600 D	160	160	2900 D	2800 D
Benzo(a)pyrene	330	1800 D	1800 D	160	160	3600 D	3400 D
Benzo(b)fluoranthene	370	2100 D	2100 D	200	200	4600 D	3900 D
Benzo(g,h,i)perylene	170	800 D	800 D	92	92	1900 DJ	2100 DJ
Benzo(k)fluoranthene	130	760 D	760 D	88	88	1900 D	1700 D
Chrysene	330	1600 D	1600 D	180	180	3400 D	3200 D
Dibenz(a,h)anthracene	40	220 D	220 D	22	22	490 DJ	540 DJ
Fluoranthene	430	2100 D	2100 D	300	300	4600 D	4200 D
Fluorene	48	240 D	240 D	35	35	440 D	480 D
Indeno(1,2,3-c,d)Pyrene	140	730 D	730 D	75	75	1800 D	1800 D
Naphthalene	60	270 D	270 D	42	42	390 D	420 D
Phenanthrene	190	1400 D	1400 D	150	150	2600 D	2700 D
Pyrene	610	2800 DJ	2800 D	370 J	370	4700 D	5100 D

µg/kg micrograms per kilogram

Bold Bolded result indicates positively identified compound.

B Analyte detected in an associated blank.

D Sample dilution required for analysis; reported values reflect the dilution.

J Data are estimated due to associated quality control data.

T Analyte was positively identified but the reported concentration is estimated; reported concentration is less than the reporting limit, but greater than the method detection limit.

UJ Potential low bias, possible false negative.

SIM Selective ion monitoring

- Not analyzed

TABLE 3

POLYNUCLEAR AROMATIC HYDROCARBONS SOLID SAMPLE DATA SUMMARY
DEMONSTRATION TESTING AND FULL-SCALE OPERATION OF THE BIOGENESIS SEDIMENT DECONTAMINATION PROCESS
KEASBEY, NEW JERSEY
 (Page 7 of 67)

Field Sample Identification	WS-190106-1602	RS-240106-1530	TS-240106-1630	RS-270106-1400	TS-270106-1401	TS-270106-1530	WS-270106-1402
Sediment Source	Lower Passaic River	Lower Passaic River	Lower Passaic River	Lower Passaic River	Lower Passaic River	Lower Passaic River	Lower Passaic River
Location Identification	WS	RS	TS	RS	TS	TS	WS
Date Collected	1/19/06	1/24/06	1/24/06	1/27/06	1/27/06	1/27/06	1/27/06
Matrix	Solid	Solid	Solid	Solid	Solid	Solid	Solid
Analyte/Methods (Units)							
Polynuclear Aromatic Hydrocarbons/SW8270C-SIM (µg/kg)							
Acenaphthene	95 D	73 TD	220 D	170 TD	470 D	180 D	100 TD
Acenaphthylene	140 D	200 D	610 D	460 D	830 D	620 D	230 TD
Anthracene	250 D	260 D	770 D	550 D	1500 D	680 D	310 D
Benzo(a)anthracene	450 D	730 D	2000 D	1400 D	2700 D	1700 D	580 D
Benzo(a)pyrene	500 D	730 D	2000 D	1400 D	2600 D	1700 D	560 D
Benzo(b)fluoranthene	700 D	910 D	2300 D	1500 D	3000 D	1900 D	810 D
Benzo(g,h,i)perylene	320 DJ	540 D	1400 D	1100 D	1800 D	1200 D	490 D
Benzo(k)fluoranthene	270 D	300 D	890 D	720 D	1300 D	730 D	260 D
Chrysene	840 D	820 D	2200 D	1500 D	2900 D	2000 D	750 D
Dibenz(a,h)anthracene	76 DJ	130 D	360 D	250 TD	440 D	310 D	110 TD
Fluoranthene	910 D	1400 D	3600 D	2800 D	5600 D	3100 D	1700 D
Fluorene	94 D	97 D	270 D	210 TD	670 D	240 D	120 TD
Indeno(1,2,3-c,d)Pyrene	280 D	440 D	1200 D	840 D	1500 D	1000 D	370 D
Naphthalene	100 D	62 TD	200 D	120 TD	270 D	150 D	<240 D
Phenanthrene	370 D	540 D	1500 D	1100 D	3800 D	1300 D	440 D
Pyrene	1000 D	1200 D	2900 D	2200 D	4200 D	2400 D	1300 D

µg/kg micrograms per kilogram

Bold Bolded result indicates positively identified compound.

B Analyte detected in an associated blank.

D Sample dilution required for analysis; reported values reflect the dilution.

J Data are estimated due to associated quality control data.

T Analyte was positively identified but the reported concentration is estimated; reported concentration is less than the reporting limit, but greater than the method detection limit.

UJ Potential low bias, possible false negative.

SIM Selective ion monitoring

- Not analyzed

TABLE 3

POLYNUCLEAR AROMATIC HYDROCARBONS SOLID SAMPLE DATA SUMMARY
DEMONSTRATION TESTING AND FULL-SCALE OPERATION OF THE BIOGENESIS SEDIMENT DECONTAMINATION PROCESS
KEASBEY, NEW JERSEY
 (Page 8 of 67)

Field Sample Identification	WS-270106-1531	RS-300106-1700	WS2-300106-1702	RS-310106-1700	TS-310106-1701	WS-310106-1702	RS-010206-1600
Sediment Source	Lower Passaic River	Raritan River	Raritan River	Raritan River	Raritan River	Raritan River	Raritan River
Location Identification	WS	RS	WS2	RS	TS	WS	RS
Date Collected	1/27/06	1/30/06	1/30/06	1/31/06	1/31/06	1/31/06	2/1/06
Matrix	Solid	Solid	Solid	Solid	Solid	Solid	Solid
Analyte/Methods (Units)							
Polynuclear Aromatic Hydrocarbons/SW8270C-SIM (µg/kg)							
Acenaphthene	<320 D	79	160 D	28 T	52 D	22 TD	50
Acenaphthylene	200 TD	200	330 D	67 T	97 D	52 D	93
Anthracene	240 TD	300	480 D	110	210 D	80 D	200
Benzo(a)anthracene	470 D	740	1200 D	250	460 D	140 D	460
Benzo(a)pyrene	470 D	780	1200 D	280	470 D	120 D	520
Benzo(b)fluoranthene	670 D	950	1500 D	300	470 D	160 D	490
Benzo(g,h,i)perylene	420 D	540	880 D	220	300 D	100 D	370
Benzo(k)fluoranthene	220 TD	310	700 D	120	200 D	63 D	180
Chrysene	630 D	840	1600 D	260	500 D	150 D	450
Dibenz(a,h)anthracene	94 TD	130	230 D	54 T	75 D	<33 D	86
Fluoranthene	1300 D	1300	2700 D	400	810 D	280 D	580
Fluorene	<320 D	110	200 D	51 T	73 D	37 D	75
Indeno(1,2,3-c,d)Pyrene	320 D	440	740 D	170	240 D	82 D	270
Naphthalene	<320 D	120	200 D	71 T	120 D	52 D	160
Phenanthrene	380 D	550	1000 D	180	420 D	120 D	290
Pyrene	1100 D	1200	2200 D	410	760 D	260 D	780

µg/kg micrograms per kilogram

Bold Bolded result indicates positively identified compound.

B Analyte detected in an associated blank.

D Sample dilution required for analysis; reported values reflect the dilution.

J Data are estimated due to associated quality control data.

T Analyte was positively identified but the reported concentration is estimated; reported concentration is less than the reporting limit, but greater than the method detection limit.

UJ Potential low bias, possible false negative.

SIM Selective ion monitoring

- Not analyzed

TABLE 3

POLYNUCLEAR AROMATIC HYDROCARBONS SOLID SAMPLE DATA SUMMARY
DEMONSTRATION TESTING AND FULL-SCALE OPERATION OF THE BIOGENESIS SEDIMENT DECONTAMINATION PROCESS
KEASBEY, NEW JERSEY
 (Page 9 of 67)

Field Sample Identification	TS-010206-1601	WS-010206-1602	RS-020206-1800	TS-020206-1801	WS-020206-1802	RS-030206-1200	TS-030206-1201
Sediment Source	Raritan River	Raritan River	Raritan River	Raritan River	Raritan River	Raritan River	Raritan River
Location Identification	TS	WS	RS	TS	WS	RS	TS
Date Collected	2/1/06	2/1/06	2/2/06	2/2/06	2/2/06	2/3/06	2/3/06
Matrix	Solid	Solid	Solid	Solid	Solid	Solid	Solid
Analyte/Methods (Units)							
Polynuclear Aromatic Hydrocarbons/SW8270C-SIM (µg/kg)							
Acenaphthene	88 D	40	35 T	73 D	25	14 TD	160 D
Acenaphthylene	130 D	97	60	100 D	56	36 D	120 D
Anthracene	340 D	130	140	230 D	62	80 D	410 D
Benzo(a)anthracene	810 D	300	310	530 D	260	180 D	850 D
Benzo(a)pyrene	770 D	310	350	530 D	290	200 D	790 D
Benzo(b)fluoranthene	780 D	340	330	540 D	260	200 D	800 D
Benzo(g,h,i)perylene	530 D	270	300	390 D	310	150 D	500 D
Benzo(k)fluoranthene	270 D	140	130	200 D	<21	74 D	310 D
Chrysene	770 D	370	300	510 D	350	180 D	870 D
Dibenz(a,h)anthracene	130 D	71	64	98 D	95	32 D	120 D
Fluoranthene	1100 D	490	450	810 D	220	260 D	1500 D
Fluorene	100 D	50	54	67 D	25	25 TD	180 D
Indeno(1,2,3-c,d)Pyrene	420 D	180	200	310 D	120	110 D	410 D
Naphthalene	250 D	66	120	200 D	36	19 TD	300 D
Phenanthrene	620 D	260	220	420 D	120	120 D	1200 D
Pyrene	1100 D	460	510	800 D	310	310 D	1500 D

µg/kg micrograms per kilogram

Bold Bolded result indicates positively identified compound.

B Analyte detected in an associated blank.

D Sample dilution required for analysis; reported values reflect the dilution.

J Data are estimated due to associated quality control data.

T Analyte was positively identified but the reported concentration is estimated; reported concentration is less than the reporting limit, but greater than the method detection limit.

UJ Potential low bias, possible false negative.

SIM Selective ion monitoring

- Not analyzed

TABLE 3

POLYNUCLEAR AROMATIC HYDROCARBONS SOLID SAMPLE DATA SUMMARY
DEMONSTRATION TESTING AND FULL-SCALE OPERATION OF THE BIOGENESIS SEDIMENT DECONTAMINATION PROCESS
KEASBEY, NEW JERSEY
 (Page 10 of 67)

Field Sample Identification	WS-030206-1202	RS-060206-1930	TS-060206-1931	WS-060206-1932	SP-070206-1445	RS-070206-1630	TS-070206-1631
Sediment Source	Raritan River	Raritan River	Raritan River	Raritan River	Raritan River	Raritan River	Raritan River
Location Identification	WS	RS	TS	WS	PPS	RS	TS
Date Collected	2/3/06	2/6/06	2/6/06	2/6/06	2/7/06	2/7/06	2/7/06
Matrix	Solid	Solid	Solid	Solid	Solid	Solid	Solid
Analyte/Methods (Units)							
Polynuclear Aromatic Hydrocarbons/SW8270C-SIM (µg/kg)							
Acenaphthene	<48 D	25 TD	38	17 T	100 D	31	41 D
Acenaphthylene	28 TD	54 D	96	43	120 D	49	110 D
Anthracene	49 D	89 D	140	87	380 D	120	400 D
Benzo(a)anthracene	75 D	220 D	290	89	400 D	260	370 D
Benzo(a)pyrene	69 D	210 D	350	80	400 D	270	430 D
Benzo(b)fluoranthene	78 D	200 D	350	87	500 D	250	530 D
Benzo(g,h,i)perylene	54 D	150 D	240	57	230 D	190	290 D
Benzo(k)fluoranthene	29 TD	74 D	140	40	<24 D	120	<16 D
Chrysene	74 D	230 D	320	91	450 D	250	390 D
Dibenz(a,h)anthracene	12 TD	<41 D	56	14 T	57 D	43	69 D
Fluoranthene	130 D	330 D	490	160	660 D	310	580 D
Fluorene	21 TD	<41 D	53	23	88 D	39	87 D
Indeno(1,2,3-c,d)Pyrene	41 TD	140 D	190	44	180 D	150	230 D
Naphthalene	38 TD	<41 D	120	40	96 D	91	160 D
Phenanthrene	75 D	170 D	270	77	440 D	160	290 D
Pyrene	150 D	390 D	430	140	640 D	430	490 D

µg/kg micrograms per kilogram

Bold Bolded result indicates positively identified compound.

B Analyte detected in an associated blank.

D Sample dilution required for analysis; reported values reflect the dilution.

J Data are estimated due to associated quality control data.

T Analyte was positively identified but the reported concentration is estimated; reported concentration is less than the reporting limit, but greater than the method detection limit.

UJ Potential low bias, possible false negative.

SIM Selective ion monitoring

- Not analyzed

TABLE 3

POLYNUCLEAR AROMATIC HYDROCARBONS SOLID SAMPLE DATA SUMMARY
DEMONSTRATION TESTING AND FULL-SCALE OPERATION OF THE BIOGENESIS SEDIMENT DECONTAMINATION PROCESS
KEASBEY, NEW JERSEY
 (Page 11 of 67)

Field Sample Identification	TS-070206-1631 DRIED	WS-070206-1632	RS-080206-1700	TS-080206-1701	WS-080206-1702	RS-090206-2300	TS-090206-2301
Sediment Source	Raritan River	Raritan River	Raritan River	Raritan River	Raritan River	Arthur Kill	Arthur Kill
Location Identification	TS	WS	RS	TS	WS	RS	TS
Date Collected	2/7/06	2/7/06	2/8/06	2/8/06	2/8/06	2/9/06	2/9/06
Matrix	Solid	Solid	Solid	Solid	Solid	Solid	Solid
Analyte/Methods (Units)							
Polynuclear Aromatic Hydrocarbons/SW8270C-SIM (µg/kg)							
Acenaphthene	70 D	22 T	31	20	28	180 D	65 D
Acenaphthylene	150 D	50	64	38	32	330 D	110 D
Anthracene	270 D	77	150	96	93	700 D	260 D
Benzo(a)anthracene	600 D	120	350	210	150	980 D	480 D
Benzo(a)pyrene	610 D	110	350	240	130	850 D	430 D
Benzo(b)fluoranthene	560 D	140	440	220	180	900 D	430 D
Benzo(g,h,i)perylene	500 D	84	230	150	86	520 D	290 D
Benzo(k)fluoranthene	260 D	47	<20	94	<23	350 D	170 D
Chrysene	630 D	130	340	210	140	1000 D	460 D
Dibenz(a,h)anthracene	110 D	21 T	62	38	21 T	140 D	75 D
Fluoranthene	840 D	230	460	300	250	1700 D	600 D
Fluorene	89 D	33	43	26	30	230 D	69 D
Indeno(1,2,3-c,d)Pyrene	380 D	64	180	120	66	400 D	230 D
Naphthalene	210 D	68	98	82	130	320 D	160 D
Phenanthrene	480 D	120	260	160	140	1300 D	390 D
Pyrene	900 D	200	480	280	240	1500 D	600 D

µg/kg micrograms per kilogram

Bold Bolded result indicates positively identified compound.

B Analyte detected in an associated blank.

D Sample dilution required for analysis; reported values reflect the dilution.

J Data are estimated due to associated quality control data.

T Analyte was positively identified but the reported concentration is estimated; reported concentration is less than the reporting limit, but greater than the method detection limit.

UJ Potential low bias, possible false negative.

SIM Selective ion monitoring

- Not analyzed

TABLE 3

POLYNUCLEAR AROMATIC HYDROCARBONS SOLID SAMPLE DATA SUMMARY
DEMONSTRATION TESTING AND FULL-SCALE OPERATION OF THE BIOGENESIS SEDIMENT DECONTAMINATION PROCESS
KEASBEY, NEW JERSEY
 (Page 12 of 67)

Field Sample Identification	WS-090206-2302	RS-130206-1700	TS-130206-1701	WS-130206-1702	RS-140206-1330	TS-140206-1331	WS-140206-1332
Sediment Source	Arthur Kill	Lower Passaic River	Lower Passaic River	Lower Passaic River	Arthur Kill	Arthur Kill	Arthur Kill
Location Identification	WS	RS	TS	WS	RS	TS	WS
Date Collected	2/9/06	2/13/06	2/13/06	2/13/06	2/14/06	2/14/06	2/14/06
Matrix	Solid	Solid	Solid	Solid	Solid	Solid	Solid
Analyte/Methods (Units)							
Polynuclear Aromatic Hydrocarbons/SW8270C-SIM (µg/kg)							
Acenaphthene	71 D	50 TD	210 D	210 D	270 D	180 D	140 D
Acenaphthylene	80 D	93 D	380 D	190 D		270 D	150 D
Anthracene	290 D	220 D	670 D	600 D	910 D	500 D	370 D
Benzo(a)anthracene	330 D	460 D	1500 D	710 D	1300 D	990 D	590 D
Benzo(a)pyrene	270 D	450 D	1200 D	550 D	1100 D	830 D	480 D
Benzo(b)fluoranthene	300 D	530 D	1300 D	660 D	1300 D	950 D	550 D
Benzo(g,h,i)perylene	170 D	320 D	770 D	340 D	700 D	570 D	290 D
Benzo(k)fluoranthene	120 D	240 D	510 D	220 D	430 D	320 D	220 D
Chrysene	350 D	540 D	1500 D	710 D	1300 D	1000 D	650 D
Dibenz(a,h)anthracene	44 TD	89 D	220 D	86 TD	210 D	180 D	83 TD
Fluoranthene	600 D	810 D	2100 D	1300 D	2200 D	1400 D	1100 D
Fluorene	60 D	58 TD	290 D	150 D	300 D	240 D	120 D
Indeno(1,2,3-c,d)Pyrene	130 D	260 D	640 D	260 D	590 D	490 D	220 D
Naphthalene	120 D	60 TD	400 D	200 D	460 D	310 D	160 D
Phenanthrene	310 D	430 D	1600 D	830 D	1600 D	1200 D	560 D
Pyrene	610 D	750 D	2000 D	1300 D	2300 D	1400 D	1000 D

µg/kg micrograms per kilogram

Bold Bolded result indicates positively identified compound.

B Analyte detected in an associated blank.

D Sample dilution required for analysis; reported values reflect the dilution.

J Data are estimated due to associated quality control data.

T Analyte was positively identified but the reported concentration is estimated; reported concentration is less than the reporting limit, but greater than the method detection limit.

UJ Potential low bias, possible false negative.

SIM Selective ion monitoring

- Not analyzed

TABLE 3

POLYNUCLEAR AROMATIC HYDROCARBONS SOLID SAMPLE DATA SUMMARY
DEMONSTRATION TESTING AND FULL-SCALE OPERATION OF THE BIOGENESIS SEDIMENT DECONTAMINATION PROCESS
KEASBEY, NEW JERSEY
 (Page 13 of 67)

Field Sample Identification	RS-160206-1500	TS-160206-1501	WS-160206-1502	RS-170206-1100	TS-170206-1101	WS-170206-1102	TS-230206-0930
Sediment Source	Arthur Kill	Arthur Kill	Arthur Kill	Arthur Kill	Arthur Kill	Arthur Kill	Arthur Kill
Location Identification	RS	TS	WS	RS	TS	WS	TS
Date Collected	2/16/06	2/16/06	2/16/06	2/17/06	2/17/06	2/17/06	2/23/06
Matrix	Solid	Solid	Solid	Solid	Solid	Solid	Solid
Analyte/Methods (Units)							
Polynuclear Aromatic Hydrocarbons/SW8270C-SIM (µg/kg)							
Acenaphthene	210 D	220 D	95 D	440 D	220 D	220 D	170 D
Acenaphthylene	270 D	330 D	72 D	540 D	290 D	130 TD	290 D
Anthracene	640 D	630 D	230 D	1600 D	630 D	560 D	500 D
Benzo(a)anthracene	900 D	950 D	250 D	2100 D	1000 D	550 D	760 D
Benzo(a)pyrene	900 D	940 D	230 D	1600 D	830 D	440 D	710 D
Benzo(b)fluoranthene	960 D	1000 D	270 D	2000 D	860 D	490 D	680 D
Benzo(g,h,i)perylene	600 DJ	610 DJ	150 DJ	1400 D	650 D	330 D	570 D
Benzo(k)fluoranthene	380 D	450 D	89 D	760 D	320 D	170 D	320 D
Chrysene	1000 D	1100 D	310 D	2900 D	1100 D	640 D	870 D
Dibenz(a,h)anthracene	150 D	160 D	37 D	340 D	160 D	81 TD	140 D
Fluoranthene	1400 D	1700 D	580 D	5400 D	1600 D	1100 D	1400 D
Fluorene	230 D	290 D	79 D	440 D	240 D	170 D	210 D
Indeno(1,2,3-c,d)Pyrene	490 D	500 D	110 D	1000 D	510 D	230 D	450 D
Naphthalene	300 D	460 D	130 D	790 D	420 D	320 D	350 D
Phenanthrene	1000 D	1200 D	390 D	2200 D	1200 D	790 D	940 D
Pyrene	1400 D	1600 D	450 D	4200 D	1600 D	1100 D	1000 D

µg/kg micrograms per kilogram

Bold Bolded result indicates positively identified compound.

B Analyte detected in an associated blank.

D Sample dilution required for analysis; reported values reflect the dilution.

J Data are estimated due to associated quality control data.

T Analyte was positively identified but the reported concentration is estimated; reported concentration is less than the reporting limit, but greater than the method detection limit.

UJ Potential low bias, possible false negative.

SIM Selective ion monitoring

- Not analyzed

TABLE 3

POLYNUCLEAR AROMATIC HYDROCARBONS SOLID SAMPLE DATA SUMMARY
DEMONSTRATION TESTING AND FULL-SCALE OPERATION OF THE BIOGENESIS SEDIMENT DECONTAMINATION PROCESS
KEASBEY, NEW JERSEY
 (Page 14 of 67)

Field Sample Identification	TS-230206-0930 DRIED	RS-270206-1400	TS-270206-1350	TS-270206-1350 DRIED	TS-270206-1630	TS-270206-1630 DRIED	RS-280206-1700
Sediment Source	Arthur Kill	Lower Passaic River	Lower Passaic River	Lower Passaic River	Lower Passaic River	Lower Passaic River	Arthur Kill
Location Identification	TS	RS	TS	TS	TS	TS	RS
Date Collected	2/23/06	2/27/06	2/27/06	2/27/06	2/27/06	2/27/06	2/28/06
Matrix	Solid	Solid	Solid	Solid	Solid	Solid	Solid
Analyte/Methods (Units)							
Polynuclear Aromatic Hydrocarbons/SW8270C-SIM (µg/kg)							
Acenaphthene	160 D	150 TD	150 D	190 D	160 D	160 D	240 D
Acenaphthylene	260 D	290 D	300 D	330 D	250 D	240 D	300 D
Anthracene	480 D	450 D	430 D	570 D	430 D	470 D	590 D
Benzo(a)anthracene	780 D	950 D	940 D	1100 D	940 D	980 D	880 D
Benzo(a)pyrene	720 D	930 D	830 D	950 D	840 D	880 D	810 D
Benzo(b)fluoranthene	720 D	990 D	790 D	1000 D	850 D	900 D	710 D
Benzo(g,h,i)perylene	550 D	750 D	620 D	690 D	610 D	670 D	610 D
Benzo(k)fluoranthene	330 D	360 D	360 D	350 D	390 D	380 D	360 D
Chrysene	900 D	1200 D	990 D	1200 D	1100 D	1100 D	920 D
Dibenz(a,h)anthracene	140 D	170 TD	160 D	190 D	150 D	160 D	150 TD
Fluoranthene	1400 D	1700 D	1400 D	1900 D	1700 D	1700 D	1500 D
Fluorene	230 D	180 TD	220 D	250 D	200 D	190 D	260 D
Indeno(1,2,3-c,d)Pyrene	440 D	560 D	510 D	550 D	490 D	520 D	470 D
Naphthalene	340 D	150 TD	260 D	270 D	160 D	170 D	360 D
Phenanthrene	1000 D	860 D	1100 D	1400 D	1000 D	1100 D	1100 D
Pyrene	1300 D	1800 D	1600 D	2000 D	1700 D	1800 D	1600 D

µg/kg micrograms per kilogram

Bold Bolded result indicates positively identified compound.

B Analyte detected in an associated blank.

D Sample dilution required for analysis; reported values reflect the dilution.

J Data are estimated due to associated quality control data.

T Analyte was positively identified but the reported concentration is estimated; reported concentration is less than the reporting limit, but greater than the method detection limit.

UJ Potential low bias, possible false negative.

SIM Selective ion monitoring

- Not analyzed

TABLE 3

POLYNUCLEAR AROMATIC HYDROCARBONS SOLID SAMPLE DATA SUMMARY
DEMONSTRATION TESTING AND FULL-SCALE OPERATION OF THE BIOGENESIS SEDIMENT DECONTAMINATION PROCESS
KEASBEY, NEW JERSEY
 (Page 15 of 67)

Field Sample Identification	TS-280206-1705	WS-280206-1710	RS-010306-1700	TS-010306-1705	WS-010306-1710	RS-020306-1700	SS-020306-1400
Sediment Source	Arthur Kill	Arthur Kill	Arthur Kill	Arthur Kill	Arthur Kill	Arthur Kill	Arthur Kill
Location Identification	TS	WS	RS	TS	WS	RS	SS1
Date Collected	2/28/06	2/28/06	3/1/06	3/1/06	3/1/06	3/2/06	3/2/06
Matrix	Solid	Solid	Solid	Solid	Solid	Solid	Solid
Analyte/Methods (Units)							
Polynuclear Aromatic Hydrocarbons/SW8270C-SIM (µg/kg)							
Acenaphthene	180 D	250 TD	370 D	240 D	170 D	320 D	3400 D
Acenaphthylene	330 D	180 TD	450 D	410 D	140 D	380 D	3500 D
Anthracene	530 D	490 D	890 D	710 D	420 D	800 D	7500 D
Benzo(a)anthracene	840 D	530 D	1300 D	990 D	420 D	1100 D	9100 D
Benzo(a)pyrene	760 D	420 D	1300 D	830 D	340 D	980 D	3500 D
Benzo(b)fluoranthene	770 D	480 D	1400 D	870 D	360 D	990 D	3100 D
Benzo(g,h,i)perylene	600 D	340 D	970 D	630 D	260 D	810 D	2200 D
Benzo(k)fluoranthene	290 D	160 TD	550 D	300 D	170 D	400 D	1200 D
Chrysene	920 D	560 D	1700 D	1100 D	540 D	1300 D	10000 D
Dibenz(a,h)anthracene	150 D	83 TD	240 D	170 D	64 D	190 D	570 D
Fluoranthene	1600 D	1100 D	2600 D	1600 D	960 D	2200 D	18000 D
Fluorene	260 D	220 TD	400 D	350 D	140 D	370 D	5300 D
Indeno(1,2,3-c,d)Pyrene	470 D	250 TD	770 D	480 D	190 D	610 D	1800 D
Naphthalene	380 D	350 D	510 D	460 D	260 D	420 D	4300 D
Phenanthrene	1100 D	840 D	1900 D	1600 D	640 D	1500 D	23000 D
Pyrene	1600 D	1200 D	2500 D	1800 D	840 D	1900 D	16000 D

µg/kg micrograms per kilogram

Bold Bolded result indicates positively identified compound.

B Analyte detected in an associated blank.

D Sample dilution required for analysis; reported values reflect the dilution.

J Data are estimated due to associated quality control data.

T Analyte was positively identified but the reported concentration is estimated; reported concentration is less than the reporting limit, but greater than the method detection limit.

UJ Potential low bias, possible false negative.

SIM Selective ion monitoring

- Not analyzed

TABLE 3

POLYNUCLEAR AROMATIC HYDROCARBONS SOLID SAMPLE DATA SUMMARY
DEMONSTRATION TESTING AND FULL-SCALE OPERATION OF THE BIOGENESIS SEDIMENT DECONTAMINATION PROCESS
KEASBEY, NEW JERSEY
 (Page 16 of 67)

Field Sample Identification	TS-020306-1705	WS-020306-1710	RS-030306-1200	TS-030306-1205	WS-030306-1210	HYDROCYCLON E OVERFLOW	HYDROCYCLON ES
Sediment Source	Arthur Kill	Arthur Kill	Arthur Kill	Arthur Kill	Arthur Kill	Lower Passaic River	Lower Passaic River
Location Identification	TS	WS	RS	TS	WS	HO	TS2
Date Collected	3/2/06	3/2/06	3/3/06	3/3/06	3/3/06	3/16/06	3/16/06
Matrix	Solid	Solid	Solid	Solid	Solid	Solid	Solid
Analyte/Methods (Units)							
Polynuclear Aromatic Hydrocarbons/SW8270C-SIM (µg/kg)							
Acenaphthene	170 D	200 D	240 D	220 D	100 D	150 TD	84 TD
Acenaphthylene	270 D	170 D	310 D	370 D	110 D	400 D	190 D
Anthracene	480 D	500 D	660 D	630 D	310 D	540 D	290 D
Benzo(a)anthracene	690 D	450 D	940 D	790 D	250 D	1100 D	700 D
Benzo(a)pyrene	630 D	380 D	800 D	750 D	210 D	1100 D	720 D
Benzo(b)fluoranthene	650 D	450 D	780 D	730 D	230 D	1200 D	760 D
Benzo(g,h,i)perylene	540 D	270 D	670 D	610 D	170 D	1100 D	650 D
Benzo(k)fluoranthene	240 D	160 D	340 D	340 D	96 D	600 D	360 D
Chrysene	790 D	610 D	1100 D	1000 D	340 D	1500 D	920 D
Dibenz(a,h)anthracene	130 D	72 D	160 D	160 D	42 TD	270 D	150 D
Fluoranthene	1200 D	1200 D	1900 D	1700 D	650 D	2600 D	1700 D
Fluorene	200 D	170 D	270 D	270 D	100 D	190 TD	100 D
Indeno(1,2,3-c,d)Pyrene	410 D	200 D	500 D	460 D	120 D	810 D	480 D
Naphthalene	320 D	330 D	330 D	350 D	130 D	130 TD	71 TD
Phenanthrene	800 D	730 D	1400 D	1200 D	410 D	940 D	580 D
Pyrene	1100 D	900 D	1500 D	1300 D	510 D	2100 D	1200 D

µg/kg micrograms per kilogram

Bold Bolded result indicates positively identified compound.

B Analyte detected in an associated blank.

D Sample dilution required for analysis; reported values reflect the dilution.

J Data are estimated due to associated quality control data.

T Analyte was positively identified but the reported concentration is estimated; reported concentration is less than the reporting limit, but greater than the method detection limit.

UJ Potential low bias, possible false negative.

SIM Selective ion monitoring

- Not analyzed

TABLE 3

POLYNUCLEAR AROMATIC HYDROCARBONS SOLID SAMPLE DATA SUMMARY
DEMONSTRATION TESTING AND FULL-SCALE OPERATION OF THE BIOGENESIS SEDIMENT DECONTAMINATION PROCESS
KEASBEY, NEW JERSEY
 (Page 17 of 67)

Field Sample Identification	SCALPING SCREEN	SEC SCREEN- EFFLUENT	SEC SCREEN- INFLUENT	SEC SCREEN- SCREENINGS	PSS-210306-0915	PSS-210306-0915- AD	PSS-210306-0915- RR
Sediment Source	Lower Passaic River	Lower Passaic River	Lower Passaic River	Lower Passaic River	Arthur Kill	Arthur Kill	Arthur Kill
Location Identification	TS1	RS	PSS	SS1	PSS	PSS	PSS
Date Collected	3/16/06	3/16/06	3/16/06	3/16/06	3/21/06	3/21/06	3/21/06
Matrix	Solid	Solid	Solid	Solid	Solid	Solid	Solid
Analyte/Methods (Units)							
Polynuclear Aromatic Hydrocarbons/SW8270C-SIM (µg/kg)							
Acenaphthene	750 D	210 TD	250 D	300 D	260 D	380 DJ	290 D
Acenaphthylene	2700 D	470 D	570 D	880 D	510 D	640 DJ	350 D
Anthracene	2800 D	690 D	790 D	1000 D	810 D	1600 DJ	810 D
Benzo(a)anthracene	6800 D	1400 D	2000 D	2600 D	1400 D	2400 DJ	1600 D
Benzo(a)pyrene	6500 D	1500 D	1900 D	2000 D	1400 D	2000 DJ	1500 D
Benzo(b)fluoranthene	6200 D	1600 D	2100 D	2100 D	1600 D	2200 DJ	1700 D
Benzo(g,h,i)perylene	4700 D	1300 D	1500 D	1300 D	1000 D	1500 DJ	1100 D
Benzo(k)fluoranthene	2200 D	710 D	910 D	980 D	720 D	770 DJ	570 D
Chrysene	8100 D	1900 D	2400 D	3200 D	1500 D	2400 DJ	1700 D
Dibenz(a,h)anthracene	1200 D	300 D	380 D	350 D	300 D	430 DJ	290 D
Fluoranthene	11000 D	3400 D	4200 D	6500 D	2800 D	4700 DJ	2800 D
Fluorene	910 D	250 D	290 D	330 D	280 D	390 DJ	230 D
Indeno(1,2,3-c,d)Pyrene	3500 D	1000 D	1100 D	1000 D	830 D	1300 DJ	890 D
Naphthalene	460 D	170 TD	210 TD	170 TD	340 D	440 DJ	400 D
Phenanthrene	4500 D	1300 D	1500 D	1700 D	1300 D	3100 DJ	1100 D
Pyrene	7900 D	2400 D	3200 D	4600 D	2800 D	3600 DJ	2800 D

µg/kg micrograms per kilogram

Bold Bolded result indicates positively identified compound.

B Analyte detected in an associated blank.

D Sample dilution required for analysis; reported values reflect the dilution.

J Data are estimated due to associated quality control data.

T Analyte was positively identified but the reported concentration is estimated; reported concentration is less than the reporting limit, but greater than the method detection limit.

UJ Potential low bias, possible false negative.

SIM Selective ion monitoring

- Not analyzed

TABLE 3

POLYNUCLEAR AROMATIC HYDROCARBONS SOLID SAMPLE DATA SUMMARY
DEMONSTRATION TESTING AND FULL-SCALE OPERATION OF THE BIOGENESIS SEDIMENT DECONTAMINATION PROCESS
KEASBEY, NEW JERSEY
 (Page 18 of 67)

Field Sample Identification	PSS-210306-0915-RR1	SS1-210306-0920	SS1-210306-0920-RR	SS1-210306-0920-RR	SS2-210306-0925	SS2-210306-0925-RR	RS-210306-0930
Sediment Source	Arthur Kill	Arthur Kill	Arthur Kill	Arthur Kill	Arthur Kill	Arthur Kill	Arthur Kill
Location Identification	PSS	SS1	SS1	SS1	SS2	SS2	RS
Date Collected	3/21/06	3/21/06	3/21/06	3/21/06	3/21/06	3/21/06	3/21/06
Matrix	Solid	Solid	Solid	Solid	Solid	Solid	Solid
Analyte/Methods (Units)							
Polynuclear Aromatic Hydrocarbons/SW8270C-SIM (µg/kg)							
Acenaphthene	310 D	2200 D	1900 DJ	1800 DJ	2500 D	990 D	7000 D
Acenaphthylene	480 D	3700 D	1100 D	1200 D	4400 D	1500 D	7800 D
Anthracene	1100 D	5600 D	4300 DJ	4100 DJ	6400 D	4300 D	17000 D
Benzo(a)anthracene	2500 D	10000 D	6600 D	6400 D	12000 D	6800 D	20000 D
Benzo(a)pyrene	2300 D	9400 D	4700 DJ	4700 DJ	11000 D	5400 D	18000 D
Benzo(b)fluoranthene	2200 D	9100 D	5200 D	4800 D	10000 D	5300 D	18000 D
Benzo(g,h,i)perylene	1600 D	6500 D	3100 DJ	3400 DJ	7800 D	4200 D	12000 D
Benzo(k)fluoranthene	1100 D	4200 D	1800 DJ	2300 DJ	5100 D	2000 D	7000 D
Chrysene	2700 D	11000 D	6900 DJ	6200 DJ	13000 D	6300 D	34000 D
Dibenz(a,h)anthracene	490 D	2200 D	1000 D	1100 D	2700 D	1300 D	3300 D
Fluoranthene	4600 D	19000 D	15000 D	14000 D	22000 D	12000 D	53000 D
Fluorene	270 D	2900 D	2000 DJ	2000 DJ	3400 D	960 D	9100 D
Indeno(1,2,3-c,d)Pyrene	1400 D	5400 D	2700 DJ	2900 DJ	6500 D	3500 D	10000 D
Naphthalene	460 D	3000 D	3500 DJ	3400 DJ	3400 D	1000 D	11000 D
Phenanthrene	1800 D	14000 D	12000 DJ	10000 DJ	16000 D	7300 D	48000 D
Pyrene	3900 D	18000 D	10000 D	9800 D	20000 D	9300 D	44000 D

µg/kg micrograms per kilogram

Bold Bolded result indicates positively identified compound.

B Analyte detected in an associated blank.

D Sample dilution required for analysis; reported values reflect the dilution.

J Data are estimated due to associated quality control data.

T Analyte was positively identified but the reported concentration is estimated; reported concentration is less than the reporting limit, but greater than the method detection limit.

UJ Potential low bias, possible false negative.

SIM Selective ion monitoring

- Not analyzed

TABLE 3

POLYNUCLEAR AROMATIC HYDROCARBONS SOLID SAMPLE DATA SUMMARY
DEMONSTRATION TESTING AND FULL-SCALE OPERATION OF THE BIOGENESIS SEDIMENT DECONTAMINATION PROCESS
KEASBEY, NEW JERSEY
 (Page 19 of 67)

Field Sample Identification	RS-210306-0930-AD	RS-210306-0930-RR	RS-210306-0930-RR1	RS-210306-0930-RR2	RS-210306-0930-RR2-DUP	RS-210306-0930-RR2-SE	RS-210306-0930-RR2-SE-DUP
Sediment Source	Arthur Kill	Arthur Kill	Arthur Kill	Arthur Kill	Arthur Kill	Arthur Kill	Arthur Kill
Location Identification	RS	RS	RS	RS	RS	RS	RS
Date Collected	3/21/06	3/21/06	3/21/06	3/21/06	3/21/06	3/21/06	3/21/06
Matrix	Solid	Solid	Solid	Solid	Solid	Solid	Solid
Analyte/Methods (Units)							
Polynuclear Aromatic Hydrocarbons/SW8270C-SIM (µg/kg)							
Acenaphthene	210 DJ	320 TD	270 D	230 DJ	260 DJ	28 J	28 J
Acenaphthylene	430 DJ	580 D	540 D	350 DJ	440 DJ	38 J	42 J
Anthracene	760 DJ	2800 D	880 D	670 DJ	720 DJ	110 J	110 J
Benzo(a)anthracene	1400 DJ	1700 D	1700 D	1200 DJ	1400 DJ	150 J	140 J
Benzo(a)pyrene	1400 DJ	1700 D	1600 D	1300 DJ	1400 DJ	140 J	130 J
Benzo(b)fluoranthene	1400 DJ	1700 D	1500 D	1300 DJ	1500 DJ	170 J	150 J
Benzo(g,h,i)perylene	1100 DJ	1600 D	1400 D	830 DJ	910 DJ	100 J	100 J
Benzo(k)fluoranthene	620 DJ	670 D	630 D	560 DJ	670 DJ	62 J	68 J
Chrysene	1600 DJ	1900 D	1800 D	1500 DJ	1600 DJ	170 J	160 J
Dibenz(a,h)anthracene	320 DJ	400 D	340 D	210 DJ	260 DJ	26 TJ	29 J
Fluoranthene	2500 DJ	2800 D	3000 D	2000 DJ	2100 DJ	260 J	250 J
Fluorene	200 DJ	400 D	250 D	200 DJ	250 DJ	31 J	33 J
Indeno(1,2,3-c,d)Pyrene	890 DJ	1200 D	1000 D	690 DJ	800 DJ	89 J	93 J
Naphthalene	290 DJ	410 D	350 D	320 DJ	340 DJ	84 J	93 J
Phenanthrene	990 DJ	1500 D	1300 D	1000 DJ	1200 DJ	140 J	130 J
Pyrene	2300 DJ	2800 D	2700 D	2500 DJ	2800 DJ	370 J	350 J

µg/kg micrograms per kilogram

Bold Bolded result indicates positively identified compound.

B Analyte detected in an associated blank.

D Sample dilution required for analysis; reported values reflect the dilution.

J Data are estimated due to associated quality control data.

T Analyte was positively identified but the reported concentration is estimated; reported concentration is less than the reporting limit, but greater than the method detection limit.

UJ Potential low bias, possible false negative.

SIM Selective ion monitoring

- Not analyzed

TABLE 3

POLYNUCLEAR AROMATIC HYDROCARBONS SOLID SAMPLE DATA SUMMARY
DEMONSTRATION TESTING AND FULL-SCALE OPERATION OF THE BIOGENESIS SEDIMENT DECONTAMINATION PROCESS
KEASBEY, NEW JERSEY
 (Page 20 of 67)

Field Sample Identification	TS-210306-1030	TS-210306-1030-RR	TS4-210306-1130	TS1-210306-1035	TS1-210306-1035-RR	TS5-210306-1135	TS2-210306-1040
Sediment Source	Arthur Kill	Arthur Kill	Arthur Kill	Arthur Kill	Arthur Kill	Arthur Kill	Arthur Kill
Location Identification	TS	TS	TS	TS1	TS1	TS1	TS2
Date Collected	3/21/06	3/21/06	3/21/06	3/21/06	3/21/06	3/21/06	3/21/06
Matrix	Solid	Solid	Solid	Solid	Solid	Solid	Solid
Analyte/Methods (Units)							
Polynuclear Aromatic Hydrocarbons/SW8270C-SIM (µg/kg)							
Acenaphthene	550 D	230 D	210 D	81 D	460 D	740 D	130 D
Acenaphthylene	890 D	360 D	410 D	180 D	600 D	810 D	260 D
Anthracene	1500 D	670 D	810 D	240 D	1200 D	5200 D	480 D
Benzo(a)anthracene	2700 D	1300 D	1500 D	440 D	2400 D	5300 D	1000 D
Benzo(a)pyrene	2500 D	1200 D	1400 D	420 D	2300 D	4300 D	1100 D
Benzo(b)fluoranthene	2600 D	1100 D	1500 D	470 D	2100 D	4500 D	1200 D
Benzo(g,h,i)perylene	1800 D	1000 D	1300 D	340 D	2000 D	2900 D	980 D
Benzo(k)fluoranthene	1200 D	460 D	610 D	200 D	860 D	1500 D	430 D
Chrysene	2600 D	1300 D	1700 D	450 D	2400 D	5600 D	1100 D
Dibenz(a,h)anthracene	540 D	300 D	370 D	86 D	590 D	880 D	250 D
Fluoranthene	5200 D	2200 D	2500 D	840 D	4200 D	7800 D	2000 D
Fluorene	620 D	230 D	230 D	88 D	470 D	680 D	160 D
Indeno(1,2,3-c,d)Pyrene	1500 D	820 D	1000 D	270 D	1600 D	2600 D	790 D
Naphthalene	710 D	320 D	300 D	89 D	480 D	820 D	150 D
Phenanthrene	3600 D	1400 D	1300 D	410 D	2700 D	5100 D	1000 D
Pyrene	4700 D	1900 D	2600 D	860 D	3600 D	6500 D	2100 D

µg/kg micrograms per kilogram

Bold Bolded result indicates positively identified compound.

B Analyte detected in an associated blank.

D Sample dilution required for analysis; reported values reflect the dilution.

J Data are estimated due to associated quality control data.

T Analyte was positively identified but the reported concentration is estimated; reported concentration is less than the reporting limit, but greater than the method detection limit.

UJ Potential low bias, possible false negative.

SIM Selective ion monitoring

- Not analyzed

TABLE 3

POLYNUCLEAR AROMATIC HYDROCARBONS SOLID SAMPLE DATA SUMMARY
DEMONSTRATION TESTING AND FULL-SCALE OPERATION OF THE BIOGENESIS SEDIMENT DECONTAMINATION PROCESS
KEASBEY, NEW JERSEY
 (Page 21 of 67)

Field Sample Identification	TS2-210306-1040-RR	TS6-210306-1140	TS3-210306-1045	TS7-210306-1145	TS-220306-1000	TS1-220306-1005	TS2-220306-1010
Sediment Source	Arthur Kill	Arthur Kill	Arthur Kill	Arthur Kill	Arthur Kill	Arthur Kill	Arthur Kill
Location Identification	TS2	TS2	TS3	TS3	TS	TS1	TS2
Date Collected	3/21/06	3/21/06	3/21/06	3/21/06	3/22/06	3/22/06	3/22/06
Matrix	Solid	Solid	Solid	Solid	Solid	Solid	Solid
Analyte/Methods (Units)							
Polynuclear Aromatic Hydrocarbons/SW8270C-SIM (µg/kg)							
Acenaphthene	120 D	210 D	150 D	130 D	300 D	700 D	120 D
Acenaphthylene	220 D	400 D	330 D	300 D	560 D	780 D	210 D
Anthracene	440 D	760 D	490 D	520 D	890 D	1800 D	410 D
Benzo(a)anthracene	1000 D	1800 D	970 D	970 D	1800 D	4100 D	930 D
Benzo(a)pyrene	1000 D	1800 D	920 D	920 D	1800 D	3800 D	950 D
Benzo(b)fluoranthene	1100 D	1800 D	900 D	880 D	2100 D	4200 D	990 D
Benzo(g,h,i)perylene	920 D	1500 D	850 D	800 D	1200 D	2900 D	680 D
Benzo(k)fluoranthene	500 D	710 D	410 D	410 D	730 D	1600 D	460 D
Chrysene	1100 D	1900 D	1000 D	1100 D	1900 D	4100 D	940 D
Dibenz(a,h)anthracene	260 D	410 D	220 D	230 D	350 D	870 D	200 D
Fluoranthene	1900 D	3000 D	1500 D	1500 D	3300 D	7100 D	1800 D
Fluorene	140 D	240 D	150 D	140 D	310 D	680 D	130 D
Indeno(1,2,3-c,d)Pyrene	760 D	1300 D	660 D	650 D	1100 D	2600 D	580 D
Naphthalene	200 D	270 D	280 D	220 D	530 D	880 D	200 D
Phenanthrene	940 D	1800 D	770 D	770 D	1800 D	5100 D	800 D
Pyrene	1600 D	3000 D	1700 D	1700 D	3200 D	6500 D	1700 D

µg/kg micrograms per kilogram

Bold Bolded result indicates positively identified compound.

B Analyte detected in an associated blank.

D Sample dilution required for analysis; reported values reflect the dilution.

J Data are estimated due to associated quality control data.

T Analyte was positively identified but the reported concentration is estimated; reported concentration is less than the reporting limit, but greater than the method detection limit.

UJ Potential low bias, possible false negative.

SIM Selective ion monitoring

- Not analyzed

TABLE 3

POLYNUCLEAR AROMATIC HYDROCARBONS SOLID SAMPLE DATA SUMMARY
DEMONSTRATION TESTING AND FULL-SCALE OPERATION OF THE BIOGENESIS SEDIMENT DECONTAMINATION PROCESS
KEASBEY, NEW JERSEY
 (Page 22 of 67)

Field Sample Identification	TS3-220306-1015	PSS-230306-1530	SS1-230306-1535	SS2-230306-1540	RS-230306-1545	TS-230306-0930	TSP-230306-1730
Sediment Source	Arthur Kill	Lower Passaic River	Lower Passaic River	Lower Passaic River	Lower Passaic River	Arthur Kill	Lower Passaic River
Location Identification	TS3	PSS	SS1	SS2	RS	TS	TS
Date Collected	3/22/06	3/23/06	3/23/06	3/23/06	3/23/06	3/23/06	3/23/06
Matrix	Solid	Solid	Solid	Solid	Solid	Solid	Solid
Analyte/Methods (Units)							
Polynuclear Aromatic Hydrocarbons/SW8270C-SIM (µg/kg)							
Acenaphthene	140 D	200 TD	720 D	580 D	290 TD	290 D	300 D
Acenaphthylene	330 D	560 D	1000 D	1500 D	660 D	500 D	540 D
Anthracene	460 D	770 D	1600 D	2100 D	970 D	840 D	1000 D
Benzo(a)anthracene	890 D	1800 D	3400 D	6200 D	2300 D	2400 D	2300 D
Benzo(a)pyrene	940 D	2100 D	2900 D	5000 D	2100 D	2200 D	2000 D
Benzo(b)fluoranthene	960 D	2500 D	2900 D	4800 D	2300 D	2200 D	2000 D
Benzo(g,h,i)perylene	730 D	1900 D	2200 D	3600 D	1800 D	1600 D	1700 D
Benzo(k)fluoranthene	420 D	1200 D	980 D	2000 D	760 D	1000 D	830 D
Chrysene	1000 D	2400 D	4000 D	7400 D	3000 D	2300 D	2500 D
Dibenz(a,h)anthracene	210 D	440 D	640 D	1200 D	480 D	440 D	480 D
Fluoranthene	1600 D	3300 D	4900 D	8400 D	4300 D	3300 D	3700 D
Fluorene	150 D	260 TD	490 TD	710 D	350 D	300 D	340 D
Indeno(1,2,3-c,d)Pyrene	580 D	1400 D	1600 D	2900 D	1500 D	1400 D	1300 D
Naphthalene	230 D	210 TD	1200 D	330 TD	290 TD	440 D	440 D
Phenanthrene	720 D	1600 D	2400 D	3400 D	1700 D	1600 D	1800 D
Pyrene	1700 D	3000 D	5100 D	6800 D	3200 D	3200 D	2900 D

µg/kg micrograms per kilogram

Bold Bolded result indicates positively identified compound.

B Analyte detected in an associated blank.

D Sample dilution required for analysis; reported values reflect the dilution.

J Data are estimated due to associated quality control data.

T Analyte was positively identified but the reported concentration is estimated; reported concentration is less than the reporting limit, but greater than the method detection limit.

UJ Potential low bias, possible false negative.

SIM Selective ion monitoring

- Not analyzed

TABLE 3

POLYNUCLEAR AROMATIC HYDROCARBONS SOLID SAMPLE DATA SUMMARY
DEMONSTRATION TESTING AND FULL-SCALE OPERATION OF THE BIOGENESIS SEDIMENT DECONTAMINATION PROCESS
KEASBEY, NEW JERSEY
 (Page 23 of 67)

Field Sample Identification	PSS-270306-1100	TS-270306-1320	PSS-300306-1300	PSS-300306-1300- DUP	PSS-300306-1300- DUP-SE	PSS-300306-1300- AD	SS1-300306-1305
Sediment Source	Lower Passaic River	Lower Passaic River	Lower Passaic River	Lower Passaic River	Lower Passaic River	Lower Passaic River	Lower Passaic River
Location Identification	PSS	TS	PSS	PSS	PSS	PSS	SS1
Date Collected	3/27/06	3/27/06	3/30/06	3/30/06	3/30/06	3/30/06	3/30/06
Matrix	Solid	Solid	Solid	Solid	Solid	Solid	Solid
Analyte/Methods (Units)							
Polynuclear Aromatic Hydrocarbons/SW8270C-SIM (µg/kg)							
Acenaphthene	190 TD	130 D	220 D	320 D	28 TD	300 DJ	220 D
Acenaphthylene	420 D	260 D	310 D	550 D	41 TD	390 D	410 D
Anthracene	640 D	490 D	620 D	870 D	98 D	780 D	920 D
Benzo(a)anthracene	1700 D	1100 D	1200 D	1500 D	140 D	1400 D	2100 D
Benzo(a)pyrene	1600 D	1100 D	1200 D	1700 D	130 D	1300 D	1800 D
Benzo(b)fluoranthene	1700 D	1200 D	1300 D	1700 D	160 D	1500 D	2000 D
Benzo(g,h,i)perylene	1400 D	940 D	940 DJ	1300 D	98 D	820 D	1500 DJ
Benzo(k)fluoranthene	830 D	540 D	480 D	700 D	58 D	520 D	910 D
Chrysene	2100 D	1900 D	1300 D	2000 D	130 D	1900 D	1900 D
Dibenz(a,h)anthracene	340 D	260 D	270 DJ	340 D	25 TD	240 D	480 DJ
Fluoranthene	3300 D	2600 D	2200 D	3000 D	220 D	2400 D	3300 D
Fluorene	230 TD	150 D	200 D	280 D	32 TD	260 D	240 D
Indeno(1,2,3-c,d)Pyrene	1100 D	750 D	740 D	1000 D	89 D	730 D	1200 D
Naphthalene	170 TD	170 D	310 D	400 D	90 D	330 DJ	440 D
Phenanthrene	1300 D	980 D	1000 D	1200 D	130 D	1100 DJ	1000 D
Pyrene	2700 D	1700 D	2000 D	2300 D	280 D	2400 DJ	2900 D

µg/kg micrograms per kilogram

Bold Bolded result indicates positively identified compound.

B Analyte detected in an associated blank.

D Sample dilution required for analysis; reported values reflect the dilution.

J Data are estimated due to associated quality control data.

T Analyte was positively identified but the reported concentration is estimated; reported concentration is less than the reporting limit, but greater than the method detection limit.

UJ Potential low bias, possible false negative.

SIM Selective ion monitoring

- Not analyzed

TABLE 3

POLYNUCLEAR AROMATIC HYDROCARBONS SOLID SAMPLE DATA SUMMARY
DEMONSTRATION TESTING AND FULL-SCALE OPERATION OF THE BIOGENESIS SEDIMENT DECONTAMINATION PROCESS
KEASBEY, NEW JERSEY
 (Page 24 of 67)

Field Sample Identification	SS1-300306-1305- DUP	SS1-300306-1305- DUP-SE	SS1-300306-1305- SE	SS1-300306-1305- AD	SS1-300306-1305- AD	SS2-300306-1310	SS2-300306-1310- DUP
Sediment Source	Lower Passaic River	Lower Passaic River	Lower Passaic River	Lower Passaic River	Lower Passaic River	Lower Passaic River	Lower Passaic River
Location Identification	SS1	SS1	SS1	SS1	SS1	SS2	SS2
Date Collected	3/30/06	3/30/06	3/30/06	3/30/06	3/30/06	3/30/06	3/30/06
Matrix	Solid	Solid	Solid	Solid	Solid	Solid	Solid
Analyte/Methods (Units)							
Polynuclear Aromatic Hydrocarbons/SW8270C-SIM (µg/kg)							
Acenaphthene	930 D	81 D	60 D	3800 DJ	-	340 D	1300 D
Acenaphthylene	750 D	71 D	100 D	910 D	-	550 D	960 D
Anthracene	1600 D	150 D	250 D	-	6800 D	1200 D	2600 D
Benzo(a)anthracene	2500 D	230 D	490 D	-	11000 D	1700 D	5300 D
Benzo(a)pyrene	2400 D	210 D	330 D	-	7700 DJ	1600 D	5000 D
Benzo(b)fluoranthene	2200 D	230 D	430 D	-	8900 DJ	1600 D	4500 D
Benzo(g,h,i)perylene	1800 D	150 D	310 D	3500 DJ	-	1200 DJ	4100 D
Benzo(k)fluoranthene	850 D	86 D	180 D	3600 DJ	-	690 D	1900 D
Chrysene	2500 D	210 D	450 D	-	12000 D	2200 D	5800 D
Dibenz(a,h)anthracene	540 D	39 D	81 D	1300 DJ	-	440 DJ	1200 D
Fluoranthene	4500 D	330 D	690 D	-	24000 D	3400 D	11000 D
Fluorene	960 D	80 DJ	62 D	4100 D	-	410 D	1300 D
Indeno(1,2,3-c,d)Pyrene	1400 D	120 D	260 D	3700 DJ	-	1000 D	3300 D
Naphthalene	870 D	100 D	230 D	-	9200 DJ	550 D	1100 D
Phenanthrene	3200 D	290 D	350 D	-	30000 D	2900 D	9100 D
Pyrene	3400 D	400 D	730 D	-	21000 D	3200 D	8400 D

µg/kg micrograms per kilogram

Bold Bolded result indicates positively identified compound.

B Analyte detected in an associated blank.

D Sample dilution required for analysis; reported values reflect the dilution.

J Data are estimated due to associated quality control data.

T Analyte was positively identified but the reported concentration is estimated; reported concentration is less than the reporting limit, but greater than the method detection limit.

UJ Potential low bias, possible false negative.

SIM Selective ion monitoring

- Not analyzed

TABLE 3

POLYNUCLEAR AROMATIC HYDROCARBONS SOLID SAMPLE DATA SUMMARY
DEMONSTRATION TESTING AND FULL-SCALE OPERATION OF THE BIOGENESIS SEDIMENT DECONTAMINATION PROCESS
KEASBEY, NEW JERSEY
 (Page 25 of 67)

Field Sample Identification	SS2-300306-1310- SE	SS2-300306-1310- DUP-SE	SS2-300306-1310- AD	RS-300306-1315	RS-300306-1315- DUP	RS-300306-1315- SE	RS-300306-1315- DUP-SE
Sediment Source	Lower Passaic River	Lower Passaic River	Lower Passaic River	Lower Passaic River	Lower Passaic River	Lower Passaic River	Lower Passaic River
Location Identification	SS2	SS2	SS2	RS	RS	RS	RS
Date Collected	3/30/06	3/30/06	3/30/06	3/30/06	3/30/06	3/30/06	3/30/06
Matrix	Solid	Solid	Solid	Solid	Solid	Solid	Solid
Analyte/Methods (Units)							
Polynuclear Aromatic Hydrocarbons/SW8270C-SIM (µg/kg)							
Acenaphthene	33 D	59 D	340 DJ	200 D	270 D	24 TD	42 TD
Acenaphthylene	29 D	70 D	590 D	280 D	520 D	32 TD	48 TD
Anthracene	80 D	150 D	940 D	650 D	760 D	81 D	120 D
Benzo(a)anthracene	94 D	190 D	1900 D	950 D	1300 D	93 D	160 D
Benzo(a)pyrene	94 D	160 D	1700 D	1100 D	1400 D	95 D	160 D
Benzo(b)fluoranthene	98 D	190 D	1700 D	1100 D	1400 D	120 D	200 D
Benzo(g,h,i)perylene	100 D	120 D	900 D	940 DJ	1200 D	71 D	140 D
Benzo(k)fluoranthene	41 D	79 D	620 D	440 D	560 D	44 D	72 D
Chrysene	85 D	210 D	2300 D	1200 D	1700 D	100 D	160 D
Dibenz(a,h)anthracene	19 TD	32 D	270 D	270 DJ	320 D	20 TD	33 TD
Fluoranthene	130 D	320 D	2800 D	1900 D	2600 D	180 D	270 D
Fluorene	38 D	68 DJ	350 D	180 D	260 D	31 TD	48 TDJ
Indeno(1,2,3-c,d)Pyrene	72 D	99 D	810 D	750 D	950 D	67 D	120 D
Naphthalene	170 D	170 D	480 DJ	260 D	320 D	89 D	100 D
Phenanthrene	140 D	320 D	1900 D	970 D	1100 D	100 D	160 D
Pyrene	180 D	430 D	2500 D	1700 D	2100 D	220 D	360 D

µg/kg micrograms per kilogram

Bold Bolded result indicates positively identified compound.

B Analyte detected in an associated blank.

D Sample dilution required for analysis; reported values reflect the dilution.

J Data are estimated due to associated quality control data.

T Analyte was positively identified but the reported concentration is estimated; reported concentration is less than the reporting limit, but greater than the method detection limit.

UJ Potential low bias, possible false negative.

SIM Selective ion monitoring

- Not analyzed

TABLE 3

POLYNUCLEAR AROMATIC HYDROCARBONS SOLID SAMPLE DATA SUMMARY
DEMONSTRATION TESTING AND FULL-SCALE OPERATION OF THE BIOGENESIS SEDIMENT DECONTAMINATION PROCESS
KEASBEY, NEW JERSEY
 (Page 26 of 67)

Field Sample Identification	RS-300306-1315-AD	TS-300306-1320	TS-300306-1320-DUP	TS-300306-1320-SE	TS-300306-1320-DUP-SE	TS-300306-1320-AD	TS1-300306-1325
Sediment Source	Lower Passaic River	Lower Passaic River	Lower Passaic River	Lower Passaic River	Lower Passaic River	Lower Passaic River	Lower Passaic River
Location Identification	RS	TS	TS	TS	TS	TS	TS1
Date Collected	3/30/06	3/30/06	3/30/06	3/30/06	3/30/06	3/30/06	3/30/06
Matrix	Solid	Solid	Solid	Solid	Solid	Solid	Solid
Analyte/Methods (Units)							
Polynuclear Aromatic Hydrocarbons/SW8270C-SIM (µg/kg)							
Acenaphthene	240 DJ	200 D	280 D	58 D	52 D	200 DJ	780 D
Acenaphthylene	280 D	430 D	610 D	94 D	82 D	370 D	1900 D
Anthracene	620 D	940 D	1000 D	250 D	240 D	650 D	2300 D
Benzo(a)anthracene	1000 D	1900 D	2000 D	350 D	300 D	1400 D	5500 D
Benzo(a)pyrene	1000 D	1900 D	2100 D	320 D	270 D	1400 D	5500 D
Benzo(b)fluoranthene	1100 D	1900 D	2200 D	400 D	320 D	1600 D	5000 D
Benzo(g,h,i)perylene	520 D	1500 DJ	1900 D	270 D	230 D	780 D	4200 D
Benzo(k)fluoranthene	380 D	800 D	1000 D	130 D	120 D	540 D	2100 D
Chrysene	1500 D	3400 D	4000 D	390 D	360 D	3000 D	6900 D
Dibenz(a,h)anthracene	150 D	420 DJ	520 D	63 D	50 D	240 D	1200 D
Fluoranthene	2000 D	3400 D	4200 D	610 D	530 D	2600 D	9500 D
Fluorene	200 D	220 D	320 D	88 D	84 D	230 D	940 D
Indeno(1,2,3-c,d)Pyrene	480 D	1300 D	1500 D	220 D	180 D	680 D	3200 D
Naphthalene	250 DJ	290 D	350 D	160 D	160 D	240 DJ	950 D
Phenanthrene	1100 D	1600 D	1800 D	420 D	400 D	1400 D	5300 D
Pyrene	1600 D	2400 D	2800 D	640 D	540 D	2000 D	7300 D

µg/kg micrograms per kilogram

Bold Bolded result indicates positively identified compound.

B Analyte detected in an associated blank.

D Sample dilution required for analysis; reported values reflect the dilution.

J Data are estimated due to associated quality control data.

T Analyte was positively identified but the reported concentration is estimated; reported concentration is less than the reporting limit, but greater than the method detection limit.

UJ Potential low bias, possible false negative.

SIM Selective ion monitoring

- Not analyzed

TABLE 3

POLYNUCLEAR AROMATIC HYDROCARBONS SOLID SAMPLE DATA SUMMARY
DEMONSTRATION TESTING AND FULL-SCALE OPERATION OF THE BIOGENESIS SEDIMENT DECONTAMINATION PROCESS
KEASBEY, NEW JERSEY
 (Page 27 of 67)

Field Sample Identification	TS1-300306-1325- DUP	TS1-300306-1325- SE	TS1-300306-1325- DUP-SE	TS1-300306-1325- AD	TS2-300306-1330	TS2-300306-1330- DUP	TS2-300306-1330- SE
Sediment Source	Lower Passaic River	Lower Passaic River	Lower Passaic River	Lower Passaic River	Lower Passaic River	Lower Passaic River	Lower Passaic River
Location Identification	TS1	TS1	TS1	TS1	TS2	TS2	TS2
Date Collected	3/30/06	3/30/06	3/30/06	3/30/06	3/30/06	3/30/06	3/30/06
Matrix	Solid	Solid	Solid	Solid	Solid	Solid	Solid
Analyte/Methods (Units)							
Polynuclear Aromatic Hydrocarbons/SW8270C-SIM (µg/kg)							
Acenaphthene	900 D	170 D	87 D	790 DJ	160 D	190 D	23 D
Acenaphthylene	2200 D	310 D	130 D	1900 D	300 D	400 D	34 D
Anthracene	2900 D	470 D	250 D	2700 D	590 D	600 D	77 D
Benzo(a)anthracene	6500 D	890 D	330 D	5800 D	1500 D	1600 D	150 D
Benzo(a)pyrene	6700 D	850 D	300 D	5500 D	1500 D	1600 D	140 D
Benzo(b)fluoranthene	5700 D	890 D	310 D	5400 D	1500 D	1600 D	170 D
Benzo(g,h,i)perylene	4500 D	600 D	200 D	3000 D	1100 DJ	1500 D	110 D
Benzo(k)fluoranthene	2400 D	290 D	120 D	2300 D	580 D	630 D	57 D
Chrysene	8700 D	930 D	350 D	7600 D	2000 D	2200 D	160 D
Dibenz(a,h)anthracene	1300 D	150 D	50 TD	960 D	310 DJ	380 D	29 D
Fluoranthene	11000 D	1300 D	530 D	8400 D	2500 D	3000 D	260 D
Fluorene	1000 D	210 D	110 D	930 D	170 D	210 D	31 D
Indeno(1,2,3-c,d)Pyrene	3600 D	490 D	160 D	2700 D	970 D	1200 D	93 D
Naphthalene	910 D	400 D	380 D	690 DJ	190 D	200 D	66 D
Phenanthrene	6200 D	1000 D	470 D	6000 D	1300 D	1400 D	170 D
Pyrene	7000 D	1400 D	590 D	7300 D	2000 D	2200 D	270 D

µg/kg micrograms per kilogram

Bold Bolded result indicates positively identified compound.

B Analyte detected in an associated blank.

D Sample dilution required for analysis; reported values reflect the dilution.

J Data are estimated due to associated quality control data.

T Analyte was positively identified but the reported concentration is estimated; reported concentration is less than the reporting limit, but greater than the method detection limit.

UJ Potential low bias, possible false negative.

SIM Selective ion monitoring

- Not analyzed

TABLE 3

POLYNUCLEAR AROMATIC HYDROCARBONS SOLID SAMPLE DATA SUMMARY
DEMONSTRATION TESTING AND FULL-SCALE OPERATION OF THE BIOGENESIS SEDIMENT DECONTAMINATION PROCESS
KEASBEY, NEW JERSEY
 (Page 28 of 67)

Field Sample Identification	TS2-300306-1330- DUP-SE	TS2-300306-1330- AD	TS3-300306-1335	TS3-300306-1335- DUP	TS3-300306-1335- SE	TS3-300306-1335- DUP-SE	TS3-300306-1335- AD
Sediment Source	Lower Passaic River	Lower Passaic River	Lower Passaic River	Lower Passaic River	Lower Passaic River	Lower Passaic River	Lower Passaic River
Location Identification	TS2	TS2	TS3	TS3	TS3	TS3	TS3
Date Collected	3/30/06	3/30/06	3/30/06	3/30/06	3/30/06	3/30/06	3/30/06
Matrix	Solid	Solid	Solid	Solid	Solid	Solid	Solid
Analyte/Methods (Units)							
Polynuclear Aromatic Hydrocarbons/SW8270C-SIM (µg/kg)							
Acenaphthene	24 D	170 DJ	200 D	170 D	120 D	98 TD	200 DJ
Acenaphthylene	27 D	320 D	380 D	400 D	230 D	160 TD	470 D
Anthracene	78 D	560 D	770 D	570 D	500 D	360 D	740 D
Benzo(a)anthracene	160 D	1500 D	1600 D	1200 D	880 D	630 D	1500 D
Benzo(a)pyrene	150 D	1500 D	1600 D	1200 D	800 D	570 D	1500 D
Benzo(b)fluoranthene	160 D	1500 D	1700 D	1300 D	950 D	720 D	1900 D
Benzo(g,h,i)perylene	110 D	860 D	1200 DJ	1200 D	680 D	480 D	920 D
Benzo(k)fluoranthene	72 D	630 D	580 D	570 D	420 D	280 D	790 D
Chrysene	170 D	2300 D	2800 D	2000 D	980 D	730 D	3700 D
Dibenz(a,h)anthracene	29 D	260 D	330 DJ	330 D	170 D	120 TD	260 D
Fluoranthene	250 D	2600 D	2900 D	2400 D	1400 D	1200 D	2900 D
Fluorene	32 D	190 D	220 D	190 D	170 D	130 TD	230 D
Indeno(1,2,3-c,d)Pyrene	93 D	790 D	990 D	940 D	540 D	390 D	820 D
Naphthalene	75 D	160 DJ	300 D	220 D	260 D	210 D	230 DJ
Phenanthrene	170 D	1400 D	1300 D	960 D	890 D	660 D	1300 D
Pyrene	300 D	2200 D	2100 D	1800 D	1500 D	1200 D	2100 D

µg/kg micrograms per kilogram

Bold Bolded result indicates positively identified compound.

B Analyte detected in an associated blank.

D Sample dilution required for analysis; reported values reflect the dilution.

J Data are estimated due to associated quality control data.

T Analyte was positively identified but the reported concentration is estimated; reported concentration is less than the reporting limit, but greater than the method detection limit.

UJ Potential low bias, possible false negative.

SIM Selective ion monitoring

- Not analyzed

TABLE 3

POLYNUCLEAR AROMATIC HYDROCARBONS SOLID SAMPLE DATA SUMMARY
DEMONSTRATION TESTING AND FULL-SCALE OPERATION OF THE BIOGENESIS SEDIMENT DECONTAMINATION PROCESS
KEASBEY, NEW JERSEY
 (Page 29 of 67)

Field Sample Identification	CENTRATE 1	CENTRATE 1-DUP	CENTRATE 1-DUP-SE	CENTRATE 1-SE	CENTRATE 1-AD	WS-300306-1345	WS-300306-1345-DUP
Sediment Source	Lower Passaic River	Lower Passaic River	Lower Passaic River	Lower Passaic River	Lower Passaic River	Lower Passaic River	Lower Passaic River
Location Identification	C1	C1	C1	C1	C1	WS	WS
Date Collected	3/30/06	3/30/06	3/30/06	3/30/06	3/30/06	3/30/06	3/30/06
Matrix	Solid	Solid	Solid	Solid	Solid	Solid	Solid
Analyte/Methods (Units)							
Polynuclear Aromatic Hydrocarbons/SW8270C-SIM (µg/kg)							
Acenaphthene	170 TD	230 TD	79 T	91 T	390 TDJ	280 TD	340 D
Acenaphthylene	360 TD	600 D	98 T	140 T	810 TD	490 D	640 D
Anthracene	610 D	720 D	230	250	1000 D	740 D	1300 D
Benzo(a)anthracene	1100 D	1200 D	410	430	1600 D	1300 D	1600 D
Benzo(a)pyrene	1100 D	1200 D	350	400	1500 D	1200 D	1600 D
Benzo(b)fluoranthene	1200 D	1300 D	510	560	1800 D	1500 D	1900 D
Benzo(g,h,i)perylene	900 D	1200 D	300	360	1100 D	1100 DJ	1400 D
Benzo(k)fluoranthene	550 D	550 D	170	190	880 D	650 D	680 D
Chrysene	1700 D	1900 D	460	520	2600 D	2400 D	3500 D
Dibenz(a,h)anthracene	260 TD	290 TD	74 T	91 T	270 TD	270 TDJ	370 D
Fluoranthene	2100 D	2700 D	770	860	3400 D	3500 D	4200 D
Fluorene	180 TD	250 TD	84 T	95 T	390 TD	280 TD	360 D
Indeno(1,2,3-c,d)Pyrene	740 D	950 D	250	300	940 D	900 D	1100 D
Naphthalene	170 TD	180 TD	92 T	93 T	<820 DUJ	280 TD	320 D
Phenanthrene	710 D	900 D	350	350	1500 D	1100 D	1400 D
Pyrene	1800 D	2200 D	970	970	3000 D	2500 D	2700 D

µg/kg micrograms per kilogram

Bold Bolded result indicates positively identified compound.

B Analyte detected in an associated blank.

D Sample dilution required for analysis; reported values reflect the dilution.

J Data are estimated due to associated quality control data.

T Analyte was positively identified but the reported concentration is estimated; reported concentration is less than the reporting limit, but greater than the method detection limit.

UJ Potential low bias, possible false negative.

SIM Selective ion monitoring

- Not analyzed

TABLE 3

POLYNUCLEAR AROMATIC HYDROCARBONS SOLID SAMPLE DATA SUMMARY
DEMONSTRATION TESTING AND FULL-SCALE OPERATION OF THE BIOGENESIS SEDIMENT DECONTAMINATION PROCESS
KEASBEY, NEW JERSEY
 (Page 30 of 67)

Field Sample Identification	WS-300306-1345-SE	WS-300306-1345-DUP-SE	WS-300306-1345-AD	PSS-030406-1500	SS1-030406-1505	SS1-030406-1505	SS2-030406-1510
Sediment Source	Lower Passaic River	Lower Passaic River	Lower Passaic River	Arthur Kill	Arthur Kill	Arthur Kill	Arthur Kill
Location Identification	WS	WS	WS	PSS	SS1	SS1	SS2
Date Collected	3/30/06	3/30/06	3/30/06	4/3/06	4/3/06	4/3/06	4/3/06
Matrix	Solid	Solid	Solid	Solid	Solid	Solid	Solid
Analyte/Methods (Units)							
Polynuclear Aromatic Hydrocarbons/SW8270C-SIM (µg/kg)							
Acenaphthene	190 TD	150 TD	320 DJ	270 D	2000 D	2100 D	1000 D
Acenaphthylene	290 D	230 TD	480 D	390 D	930 D	1200 D	1500 D
Anthracene	590 D	500 D	890 D	850 D	4700 D	5600 D	2700 D
Benzo(a)anthracene	940 D	840 D	1500 D	1300 D	7000 D	8500 D	5700 D
Benzo(a)pyrene	850 D	710 D	1400 D	1300 D	5400 D	5700 D	4300 D
Benzo(b)fluoranthene	1200 D	1000 D	2000 D	1400 D	5700 D	6500 D	4900 D
Benzo(g,h,i)perylene	730 D	580 D	790 D	760 D	2700 D	2900 D	2300 D
Benzo(k)fluoranthene	420 D	370 D	670 D	550 D	2800 D	3000 D	2200 D
Chrysene	1200 D	950 D	4500 D	1700 D	9000 D	8700 D	7700 D
Dibenz(a,h)anthracene	190 TD	140 TD	230 D	180 D	980 D	900 D	670 D
Fluoranthene	2100 D	1600 D	3700 D	2100 D	11000 D	13000 D	12000 D
Fluorene	200 TD	150 TD	310 D	230 D	2200 D	2600 D	1200 D
Indeno(1,2,3-c,d)Pyrene	640 D	510 D	760 D	610 D	2700 D	2900 D	2200 D
Naphthalene	200 TD	170 TD	220 DJ	320 D	3600 D	4200 D	3700 D
Phenanthrene	900 D	670 D	1400 D	1600 D	17000 D	17000 D	10000 D
Pyrene	2200 D	1800 D	2300 D	2000 DJ	9400 DJ	12000 D	11000 DJ

µg/kg micrograms per kilogram

Bold Bolded result indicates positively identified compound.

B Analyte detected in an associated blank.

D Sample dilution required for analysis; reported values reflect the dilution.

J Data are estimated due to associated quality control data.

T Analyte was positively identified but the reported concentration is estimated; reported concentration is less than the reporting limit, but greater than the method detection limit.

UJ Potential low bias, possible false negative.

SIM Selective ion monitoring

- Not analyzed

TABLE 3

POLYNUCLEAR AROMATIC HYDROCARBONS SOLID SAMPLE DATA SUMMARY
DEMONSTRATION TESTING AND FULL-SCALE OPERATION OF THE BIOGENESIS SEDIMENT DECONTAMINATION PROCESS
KEASBEY, NEW JERSEY
 (Page 31 of 67)

Field Sample Identification	RS-030406-1515	FD-431520	INF-431525	TS-030406-1540	TS1-030406-1525	TS2-030406-1530	TS3-030406-1535
Sediment Source	Arthur Kill	Arthur Kill	Arthur Kill	Arthur Kill	Arthur Kill	Arthur Kill	Arthur Kill
Location Identification	RS	RS Dup	RS Dup	TS	TS1	TS2	TS3
Date Collected	4/3/06	4/3/06	4/3/06	4/3/06	4/3/06	4/3/06	4/3/06
Matrix	Solid	Solid	Solid	Solid	Solid	Solid	Solid
Analyte/Methods (Units)							
Polynuclear Aromatic Hydrocarbons/SW8270C-SIM (µg/kg)							
Acenaphthene	330 D	300 D	260 D	330 D	480 D	1100 D	190 D
Acenaphthylene	530 D	490 D	480 D	620 D	860 D	1500 D	400 D
Anthracene	830 D	920 D	910 D	900 D	1500 D	3400 D	540 D
Benzo(a)anthracene	1500 D	1400 D	1400 D	1800 D	3400 D	6700 D	900 D
Benzo(a)pyrene	1400 D	1300 D	1500 D	1700 D	3000 D	5800 D	890 D
Benzo(b)fluoranthene	1500 D	1300 D	1500 D	1600 D	2700 D	5400 D	870 D
Benzo(g,h,i)perylene	930 D	670 D	770 D	1100 D	1800 D	3100 D	560 D
Benzo(k)fluoranthene	650 D	570 D	640 D	790 D	1200 D	2600 D	400 D
Chrysene	2000 D	1900 D	1900 D	2100 D	3600 D	6800 D	1100 D
Dibenz(a,h)anthracene	250 D	230 D	230 D	420 D	490 D	1000 D	160 D
Fluoranthene	2400 D	2400 D	2300 D	2600 D	4800 D	10000 D	1400 D
Fluorene	340 D	270 D	230 D	360 D	560 D	1200 D	180 D
Indeno(1,2,3-c,d)Pyrene	810 D	640 D	750 D	1200 D	1600 D	3000 D	470 D
Naphthalene	440 D	390 D	310 D	530 D	530 D	1400 D	300 D
Phenanthrene	1600 D	1500 D	1300 D	2300 D	3200 D	8800 D	780 D
Pyrene	2700 DJ	2100 DJ	1900 DJ	2500 DJ	5400 DJ	9700 DJ	1400 DJ

µg/kg micrograms per kilogram

Bold Bolded result indicates positively identified compound.

B Analyte detected in an associated blank.

D Sample dilution required for analysis; reported values reflect the dilution.

J Data are estimated due to associated quality control data.

T Analyte was positively identified but the reported concentration is estimated; reported concentration is less than the reporting limit, but greater than the method detection limit.

UJ Potential low bias, possible false negative.

SIM Selective ion monitoring

- Not analyzed

TABLE 3

POLYNUCLEAR AROMATIC HYDROCARBONS SOLID SAMPLE DATA SUMMARY
DEMONSTRATION TESTING AND FULL-SCALE OPERATION OF THE BIOGENESIS SEDIMENT DECONTAMINATION PROCESS
KEASBEY, NEW JERSEY
 (Page 32 of 67)

Field Sample Identification	WS-030406-1600	PSS-040406-1200	SS1-040406-1205	SS2-040406-1210	RS-040406-1215	TS-040406-1240	TS1-040406-1225
Sediment Source	Arthur Kill	Arthur Kill	Arthur Kill	Arthur Kill	Arthur Kill	Arthur Kill	Arthur Kill
Location Identification	WS	PSS	SS1	SS2	RS	TS	TS1
Date Collected	4/3/06	4/4/06	4/4/06	4/4/06	4/4/06	4/4/06	4/4/06
Matrix	Solid	Solid	Solid	Solid	Solid	Solid	Solid
Analyte/Methods (Units)							
Polynuclear Aromatic Hydrocarbons/SW8270C-SIM (µg/kg)							
Acenaphthene	360 D	290 D	380 D	1400 D	270 D	520 D	970 D
Acenaphthylene	310 D	510 D	360 D	1100 D	470 D	940 D	1300 D
Anthracene	790 D	1000 D	1100 D	4600 D	810 D	1500 D	2700 D
Benzo(a)anthracene	980 D	1400 D	1300 D	7200 D	1400 D	2600 D	5200 D
Benzo(a)pyrene	880 DJ	1200 D	1000 D	5600 D	1300 D	2300 D	4500 D
Benzo(b)fluoranthene	1200 DJ	1400 D	1000 D	5300 D	1300 D	2400 D	4200 D
Benzo(g,h,i)perylene	420 DJ	790 D	540 D	2600 D	730 D	1300 D	2600 D
Benzo(k)fluoranthene	380 DJ	470 D	350 D	2100 D	510 D	880 D	1700 D
Chrysene	1500 D	1600 D	1700 D	8600 D	1800 D	3000 D	5600 D
Dibenz(a,h)anthracene	140 DJ	220 TD	170 D	830 D	210 D	430 D	800 D
Fluoranthene	2300 D	2500 D	2100 D	12000 D	2300 D	4000 D	7000 D
Fluorene	230 D	280 D	300 D	2000 D	260 D	560 D	980 D
Indeno(1,2,3-c,d)Pyrene	400 DJ	680 D	470 D	2500 D	640 D	1200 D	2400 D
Naphthalene	380 D	300 D	480 D	1400 D	310 D	610 D	920 D
Phenanthrene	1000 D	1500 D	1600 D	14000 D	1300 D	3000 D	6800 D
Pyrene	1900 D	2500 D	2400 D	12000 D	1900 D	3400 D	7200 D

µg/kg micrograms per kilogram

Bold Bolded result indicates positively identified compound.

B Analyte detected in an associated blank.

D Sample dilution required for analysis; reported values reflect the dilution.

J Data are estimated due to associated quality control data.

T Analyte was positively identified but the reported concentration is estimated; reported concentration is less than the reporting limit, but greater than the method detection limit.

UJ Potential low bias, possible false negative.

SIM Selective ion monitoring

- Not analyzed

TABLE 3

POLYNUCLEAR AROMATIC HYDROCARBONS SOLID SAMPLE DATA SUMMARY
DEMONSTRATION TESTING AND FULL-SCALE OPERATION OF THE BIOGENESIS SEDIMENT DECONTAMINATION PROCESS
KEASBEY, NEW JERSEY
 (Page 33 of 67)

Field Sample Identification	TS2-040406-1230	TS3-040406-1235	WS-040406-1300	PSS-050406-1200	SS1-050406-1205	SS2-050406-1210	SS2-050406-1210
Sediment Source	Arthur Kill	Arthur Kill	Arthur Kill	Arthur Kill	Arthur Kill	Arthur Kill	Arthur Kill
Location Identification	TS2	TS3	WS	PSS	SS1	SS2	SS2
Date Collected	4/4/06	4/4/06	4/4/06	4/5/06	4/5/06	4/5/06	4/5/06
Matrix	Solid	Solid	Solid	Solid	Solid	Solid	Solid
Analyte/Methods (Units)							
Polynuclear Aromatic Hydrocarbons/SW8270C-SIM (µg/kg)							
Acenaphthene	1000 D	190 D	250 D	320 D	1600 D	810 D	820 D
Acenaphthylene	1900 D	330 D	290 D	520 D	620 D	1500 D	1500 D
Anthracene	3200 D	550 D	490 D	820 D	3400 D	2600 D	3000 D
Benzo(a)anthracene	5600 D	1200 D	840 D	1400 D	5000 D	6700 D	7000 D
Benzo(a)pyrene	5200 D	1100 D	710 D	1300 D	3600 D	5500 D	5200 D
Benzo(b)fluoranthene	4700 D	1400 D	800 D	1400 D	3500 D	6100 D	5600 D
Benzo(g,h,i)perylene	2700 D	730 D	450 D	980 D	1900 D	3000 D	2800 D
Benzo(k)fluoranthene	2200 D	<97 D	290 D	580 D	1600 D	2200 D	2000 D
Chrysene	6300 D	1400 D	1100 D	1700 D	5500 D	8000 D	8300 D
Dibenz(a,h)anthracene	880 D	190 D	110 TD	270 D	570 D	800 D	830 D
Fluoranthene	9500 D	1600 D	1400 D	2300 D	8700 D	15000 D	15000 D
Fluorene	1100 D	190 D	190 D	290 D	1700 D	880 D	830 D
Indeno(1,2,3-c,d)Pyrene	2500 D	630 D	380 D	850 D	1900 D	2700 D	2700 D
Naphthalene	1200 D	320 D	240 D	350 D	2600 D	920 D	980 D
Phenanthrene	6900 D	1100 D	930 D	1400 D	12000 D	5900 D	6300 D
Pyrene	7100 D	1900 D	1700 D	2700 DJ	8200 DJ	14000 D	11000 DJ

µg/kg micrograms per kilogram

Bold Bolded result indicates positively identified compound.

B Analyte detected in an associated blank.

D Sample dilution required for analysis; reported values reflect the dilution.

J Data are estimated due to associated quality control data.

T Analyte was positively identified but the reported concentration is estimated; reported concentration is less than the reporting limit, but greater than the method detection limit.

UJ Potential low bias, possible false negative.

SIM Selective ion monitoring

- Not analyzed

TABLE 3

POLYNUCLEAR AROMATIC HYDROCARBONS SOLID SAMPLE DATA SUMMARY
DEMONSTRATION TESTING AND FULL-SCALE OPERATION OF THE BIOGENESIS SEDIMENT DECONTAMINATION PROCESS
KEASBEY, NEW JERSEY
 (Page 34 of 67)

Field Sample Identification	RS-050406-1215	TS-050406-1240	TS1-050406-1225	TS2-050406-1230	TS3-050406-1235	WS-050406-1300	PSS-060406-1200
Sediment Source	Arthur Kill	Arthur Kill	Arthur Kill	Arthur Kill	Arthur Kill	Arthur Kill	Arthur Kill
Location Identification	RS	TS	TS1	TS2	TS3	WS	PSS
Date Collected	4/5/06	4/5/06	4/5/06	4/5/06	4/5/06	4/5/06	4/6/06
Matrix	Solid	Solid	Solid	Solid	Solid	Solid	Solid
Analyte/Methods (Units)							
Polynuclear Aromatic Hydrocarbons/SW8270C-SIM (µg/kg)							
Acenaphthene	640 D	450 D	520 D	1300 D	160 D	200 D	300 D
Acenaphthylene	1000 D	700 D	900 D	2000 D	300 D	190 D	520 D
Anthracene	2100 D	1700 D	1700 D	3800 D	440 D	480 D	780 D
Benzo(a)anthracene	3100 D	2600 D	3200 D	7800 D	900 D	530 D	1400 D
Benzo(a)pyrene	3000 D	2300 D	2800 D	7100 D	870 D	480 D	1400 D
Benzo(b)fluoranthene	2900 D	2300 D	2600 D	6900 D	810 D	670 D	1400 D
Benzo(g,h,i)perylene	1800 D	1200 D	1500 D	3900 D	550 D	260 D	740 D
Benzo(k)fluoranthene	1200 D	770 D	1100 D	2500 D	400 D	<120 D	520 D
Chrysene	4000 D	2900 D	3400 D	8200 D	1100 D	750 D	1700 D
Dibenz(a,h)anthracene	510 D	370 D	460 D	1100 D	150 D	82 TD	250 DJ
Fluoranthene	4700 D	3700 D	4800 D	12000 D	1300 D	1200 D	2100 D
Fluorene	640 D	490 D	640 D	1400 D	150 D	140 D	290 D
Indeno(1,2,3-c,d)Pyrene	1700 D	1200 D	1500 D	3800 D	490 D	250 D	720 DJ
Naphthalene	650 D	560 D	690 D	1500 D	240 D	170 D	460 D
Phenanthrene	3600 D	3200 D	4500 D	9000 D	710 D	570 D	1300 D
Pyrene	4700 DJ	3600 DJ	4500 DJ	10000 DJ	1400 DJ	1100 DJ	2200 D

µg/kg micrograms per kilogram

Bold Bolded result indicates positively identified compound.

B Analyte detected in an associated blank.

D Sample dilution required for analysis; reported values reflect the dilution.

J Data are estimated due to associated quality control data.

T Analyte was positively identified but the reported concentration is estimated; reported concentration is less than the reporting limit, but greater than the method detection limit.

UJ Potential low bias, possible false negative.

SIM Selective ion monitoring

- Not analyzed

TABLE 3

POLYNUCLEAR AROMATIC HYDROCARBONS SOLID SAMPLE DATA SUMMARY
DEMONSTRATION TESTING AND FULL-SCALE OPERATION OF THE BIOGENESIS SEDIMENT DECONTAMINATION PROCESS
KEASBEY, NEW JERSEY
 (Page 35 of 67)

Field Sample Identification	SS1-060406-1205	SS2-060406-1210	RS-060406-1215	TS-060406-1240	TS1-060406-1225	TS2-060406-1230	TS3-060406-1235
Sediment Source	Arthur Kill	Arthur Kill	Arthur Kill	Arthur Kill	Arthur Kill	Arthur Kill	Arthur Kill
Location Identification	SS1	SS2	RS	TS	TS1	TS2	TS3
Date Collected	4/6/06	4/6/06	4/6/06	4/6/06	4/6/06	4/6/06	4/6/06
Matrix	Solid	Solid	Solid	Solid	Solid	Solid	Solid
Analyte/Methods (Units)							
Polynuclear Aromatic Hydrocarbons/SW8270C-SIM (µg/kg)							
Acenaphthene	1200 D	1200 D	300 D	270 D	820 D	110 D	130 D
Acenaphthylene	1900 D	2000 D	460 D	440 D	1400 D	180 D	230 D
Anthracene	3300 D	3400 D	780 D	770 D	2200 D	340 D	370 D
Benzo(a)anthracene	5800 D	7200 D	1400 D	1600 D	4900 D	830 D	670 D
Benzo(a)pyrene	4400 D	6200 D	1400 D	1600 D	4300 D	810 D	700 D
Benzo(b)fluoranthene	4300 D	5800 D	1400 D	1700 D	4200 D	900 D	740 D
Benzo(g,h,i)perylene	2100 D	3000 D	790 D	880 D	2300 D	480 D	400 D
Benzo(k)fluoranthene	1500 D	2200 D	620 D	590 D	1900 D	390 D	330 D
Chrysene	12000 D	7400 D	1800 D	2000 DJ	5000 D	1100 D	930 D
Dibenz(a,h)anthracene	740 DJ	910 DJ	100 TDJ	260 DJ	700 DJ	130 DJ	120 DJ
Fluoranthene	9900 D	9100 D	2000 D	2400 DJ	6900 D	1500 D	1100 D
Fluorene	1800 D	1500 D	280 D	270 D	990 D	120 D	120 D
Indeno(1,2,3-c,d)Pyrene	1900 DJ	2900 DJ	690 DJ	780 DJ	2100 DJ	430 DJ	360 DJ
Naphthalene	1200 D	1400 D	330 D	280 D	1000 D	120 D	200 D
Phenanthrene	12000 D	7900 D	1200 D	1500 D	6400 D	780 D	600 D
Pyrene	10000 D	9300 D	2100 D	2600 DJ	7400 D	1800 D	1200 D

µg/kg micrograms per kilogram

Bold Bolded result indicates positively identified compound.

B Analyte detected in an associated blank.

D Sample dilution required for analysis; reported values reflect the dilution.

J Data are estimated due to associated quality control data.

T Analyte was positively identified but the reported concentration is estimated; reported concentration is less than the reporting limit, but greater than the method detection limit.

UJ Potential low bias, possible false negative.

SIM Selective ion monitoring

- Not analyzed

TABLE 3

POLYNUCLEAR AROMATIC HYDROCARBONS SOLID SAMPLE DATA SUMMARY
DEMONSTRATION TESTING AND FULL-SCALE OPERATION OF THE BIOGENESIS SEDIMENT DECONTAMINATION PROCESS
KEASBEY, NEW JERSEY
 (Page 36 of 67)

Field Sample Identification	WS-060406-1300	PSS-100406-1510	SS1-100406-1515	SS2-100406-1520	RS-100406-1525	TS-100406-1615	TS1-100406-1600
Sediment Source	Arthur Kill	Arthur Kill	Arthur Kill	Arthur Kill	Arthur Kill	Arthur Kill	Arthur Kill
Location Identification	WS	PSS	SS1	SS2	RS	TS	TS1
Date Collected	4/6/06	4/10/06	4/10/06	4/10/06	4/10/06	4/10/06	4/10/06
Matrix	Solid	Solid	Solid	Solid	Solid	Solid	Solid
Analyte/Methods (Units)							
Polynuclear Aromatic Hydrocarbons/SW8270C-SIM (µg/kg)							
Acenaphthene	180 D	400 D	350 D	1200 D	310 D	200 D	1100 D
Acenaphthylene	170 D	620 D	510 D	3400 D	550 D	370 D	2200 D
Anthracene	350 D	890 D	1100 D	3600 D	830 D	590 DJ	3700 D
Benzo(a)anthracene	430 D	1400 D	1500 D	6100 D	1500 D	1200 DJ	7800 D
Benzo(a)pyrene	410 D	1400 DJ	1200 DJ	5000 DJ	1300 DJ	1200 DJ	7000 DJ
Benzo(b)fluoranthene	480 D	1400 D	1300 D	5300 D	1400 D	1300 D	6800 D
Benzo(g,h,i)perylene	220 D	920 D	630 D	2700 D	830 D	720 D	3900 D
Benzo(k)fluoranthene	180 D	780 DJ	580 DJ	2100 DJ	660 DJ	440 DJ	3200 DJ
Chrysene	590 D	1700 D	1800 D	7000 D	1600 D	1500 DJ	8600 D
Dibenz(a,h)anthracene	63 TDJ	360 DJ	210 DJ	850 DJ	260 DJ	200 DJ	1200 DJ
Fluoranthene	900 D	2500 D	2200 D	10000 D	2400 D	1800 DJ	12000 D
Fluorene	140 D	400 D	340 D	2300 D	310 D	190 D	1300 D
Indeno(1,2,3-c,d)Pyrene	190 DJ	810 DJ	570 DJ	2500 DJ	730 DJ	630 DJ	3600 DJ
Naphthalene	150 D	410 D	450 D	2700 D	290 D	290 D	1200 D
Phenanthrene	480 D	1200 D	1200 D	10000 D	1300 D	990 DJ	8900 D
Pyrene	1100 D	3000 D	2500 D	11000 D	2500 D	1800 DJ	11000 D

µg/kg micrograms per kilogram

Bold Bolded result indicates positively identified compound.

B Analyte detected in an associated blank.

D Sample dilution required for analysis; reported values reflect the dilution.

J Data are estimated due to associated quality control data.

T Analyte was positively identified but the reported concentration is estimated; reported concentration is less than the reporting limit, but greater than the method detection limit.

UJ Potential low bias, possible false negative.

SIM Selective ion monitoring

- Not analyzed

TABLE 3

POLYNUCLEAR AROMATIC HYDROCARBONS SOLID SAMPLE DATA SUMMARY
DEMONSTRATION TESTING AND FULL-SCALE OPERATION OF THE BIOGENESIS SEDIMENT DECONTAMINATION PROCESS
KEASBEY, NEW JERSEY
 (Page 37 of 67)

Field Sample Identification	TS2-100406-1605	TS3-100406-1610	WS-100406-1630	PSS-110406-1800	SS1-110406-1805	SS2-110406-1810	RS-110406-1815
Sediment Source	Arthur Kill	Arthur Kill	Arthur Kill	Arthur Kill	Arthur Kill	Arthur Kill	Arthur Kill
Location Identification	TS2	TS3	WS	PSS	SS1	SS2	RS
Date Collected	4/10/06	4/10/06	4/10/06	4/11/06	4/11/06	4/11/06	4/11/06
Matrix	Solid	Solid	Solid	Solid	Solid	Solid	Solid
Analyte/Methods (Units)							
Polynuclear Aromatic Hydrocarbons/SW8270C-SIM (µg/kg)							
Acenaphthene	310 D	180 D	250 D	280 D	1200 D	620 D	210 D
Acenaphthylene	710 D	370 D	220 D	410 D	780 D	960 D	340 D
Anthracene	920 D	500 D	530 D	770 D	2800 D	1700 D	590 D
Benzo(a)anthracene	2400 D	1000 D	630 D	1700 D	6500 D	3500 D	1100 D
Benzo(a)pyrene	2200 DJ	990 DJ	580 DJ	1600 D	4300 D	2800 D	1100 D
Benzo(b)fluoranthene	2200 D	1000 D	720 D	1900 D	4600 D	3300 D	1300 D
Benzo(g,h,i)perylene	1400 D	620 D	280 D	790 D	1900 D	1300 D	590 D
Benzo(k)fluoranthene	1000 DJ	470 DJ	220 DJ	790 D	2000 D	1500 D	450 D
Chrysene	2500 D	1200 D	950 D	1900 D	8700 D	4200 D	1400 D
Dibenz(a,h)anthracene	400 DJ	170 DJ	92 TDJ	230 TD	550 D	400 D	170 D
Fluoranthene	3500 D	1600 D	1400 D	2700 D	12000 D	6400 D	1700 D
Fluorene	340 D	180 D	180 D	280 D	940 D	810 D	210 D
Indeno(1,2,3-c,d)Pyrene	1200 DJ	530 DJ	250 DJ	720 D	1700 D	1200 D	540 D
Naphthalene	350 D	270 D	240 D	390 D	960 D	1200 D	260 D
Phenanthrene	2100 D	860 D	800 D	1500 D	5900 D	4700 D	1200 D
Pyrene	3800 D	1800 D	1300 D	3200 D	12000 D	7400 D	2100 D

µg/kg micrograms per kilogram

Bold Bolded result indicates positively identified compound.

B Analyte detected in an associated blank.

D Sample dilution required for analysis; reported values reflect the dilution.

J Data are estimated due to associated quality control data.

T Analyte was positively identified but the reported concentration is estimated; reported concentration is less than the reporting limit, but greater than the method detection limit.

UJ Potential low bias, possible false negative.

SIM Selective ion monitoring

- Not analyzed

TABLE 3

POLYNUCLEAR AROMATIC HYDROCARBONS SOLID SAMPLE DATA SUMMARY
DEMONSTRATION TESTING AND FULL-SCALE OPERATION OF THE BIOGENESIS SEDIMENT DECONTAMINATION PROCESS
KEASBEY, NEW JERSEY
 (Page 38 of 67)

Field Sample Identification	TS-110406-1835	TS1-110406-1820	TS2-110406-1825	TS3-110406-1830	WS-110406-1840	PSS-120406-1800	SS1-120406-1805
Sediment Source	Arthur Kill	Arthur Kill	Arthur Kill	Arthur Kill	Arthur Kill	Arthur Kill	Arthur Kill
Location Identification	TS	TS1	TS2	TS3	WS	PSS	SS1
Date Collected	4/11/06	4/11/06	4/11/06	4/11/06	4/11/06	4/12/06	4/12/06
Matrix	Solid	Solid	Solid	Solid	Solid	Solid	Solid
Analyte/Methods (Units)							
Polynuclear Aromatic Hydrocarbons/SW8270C-SIM (µg/kg)							
Acenaphthene	160 D	820 D	110 D	85 D	180 D	240 D	930 TD
Acenaphthylene	300 D	1000 D	140 D	150 D	150 D	340 D	3100 D
Anthracene	490 D	2500 D	320 D	250 D	350 D	610 D	19000 D
Benzo(a)anthracene	1000 D	4700 D	780 D	510 D	420 D	1200 D	16000 D
Benzo(a)pyrene	970 D	4300 D	800 D	520 D	400 D	980 D	7100 D
Benzo(b)fluoranthene	1000 D	4600 D	900 D	550 D	460 D	1100 D	9700 D
Benzo(g,h,i)perylene	550 D	2100 D	460 D	300 D	210 D	500 D	2600 D
Benzo(k)fluoranthene	390 D	2100 D	340 D	190 D	200 D	360 D	3500 D
Chrysene	1300 D	5600 D	860 D	610 D	570 D	1300 D	16000 D
Dibenz(a,h)anthracene	150 D	660 D	120 D	82 D	66 TD	150 TD	900 TD
Fluoranthene	1600 D	7900 D	1300 D	810 D	860 D	2000 D	45000 D
Fluorene	170 D	880 D	120 D	89 D	120 TD	210 TD	2800 D
Indeno(1,2,3-c,d)Pyrene	490 D	2000 D	430 D	270 D	180 D	430 D	2400 D
Naphthalene	270 D	860 D	130 D	150 D	160 D	270 D	1900 D
Phenanthrene	910 D	6600 D	760 D	510 D	450 D	1300 D	31000 D
Pyrene	2000 D	8000 D	1600 D	990 D	1100 D	2100 D	38000 D

µg/kg micrograms per kilogram

Bold Bolded result indicates positively identified compound.

B Analyte detected in an associated blank.

D Sample dilution required for analysis; reported values reflect the dilution.

J Data are estimated due to associated quality control data.

T Analyte was positively identified but the reported concentration is estimated; reported concentration is less than the reporting limit, but greater than the method detection limit.

UJ Potential low bias, possible false negative.

SIM Selective ion monitoring

- Not analyzed

TABLE 3

POLYNUCLEAR AROMATIC HYDROCARBONS SOLID SAMPLE DATA SUMMARY
DEMONSTRATION TESTING AND FULL-SCALE OPERATION OF THE BIOGENESIS SEDIMENT DECONTAMINATION PROCESS
KEASBEY, NEW JERSEY
 (Page 39 of 67)

Field Sample Identification	SS1-120406-1805	SS2-120406-1810	RS-120406-1815	TS-120406-1835	TS1-120406-1820	TS2-120406-1825	TS3-120406-1830
Sediment Source	Arthur Kill	Arthur Kill	Arthur Kill	Arthur Kill	Arthur Kill	Arthur Kill	Arthur Kill
Location Identification	SS1	SS2	RS	TS	TS1	TS2	TS3
Date Collected	4/12/06	4/12/06	4/12/06	4/12/06	4/12/06	4/12/06	4/12/06
Matrix	Solid	Solid	Solid	Solid	Solid	Solid	Solid
Analyte/Methods (Units)							
Polynuclear Aromatic Hydrocarbons/SW8270C-SIM (µg/kg)							
Acenaphthene	680 D	440 D	160 D	230 D	590 D	120 D	160 D
Acenaphthylene	2500 D	690 D	240 D	400 D	900 D	210 D	300 D
Anthracene	17000 D	1300 D	500 D	780 D	1900 D	440 D	600 D
Benzo(a)anthracene	13000 D	2800 D	780 D	1400 D	3800 D	1100 D	990 D
Benzo(a)pyrene	5800 D	2300 D	760 D	1400 D	3500 D	920 D	910 D
Benzo(b)fluoranthene	7100 D	2400 D	860 D	1500 D	3500 D	1000 D	940 D
Benzo(g,h,i)perylene	1700 D	1000 D	410 D	740 D	1700 D	520 D	540 D
Benzo(k)fluoranthene	3500 D	1000 D	310 D	520 D	1700 D	490 D	380 D
Chrysene	13000 D	2900 D	970 D	1700 D	4000 D	1200 D	1200 D
Dibenz(a,h)anthracene	780 D	410 D	130 D	260 D	650 D	170 D	170 D
Fluoranthene	48000 D	3800 D	1500 D	2500 D	6900 D	1700 D	1800 D
Fluorene	1800 D	440 D	140 D	210 D	610 D	120 D	150 D
Indeno(1,2,3-c,d)Pyrene	1700 D	1000 D	370 D	660 D	1600 D	480 D	480 D
Naphthalene	1500 D	630 D	190 D	430 D	840 D	170 D	310 D
Phenanthrene	43000 D	3700 D	1100 D	1900 D	5400 D	950 D	970 D
Pyrene	24000 D	3400 D	1200 D	1900 D	4700 D	1500 D	1700 D

µg/kg micrograms per kilogram

Bold Bolded result indicates positively identified compound.

B Analyte detected in an associated blank.

D Sample dilution required for analysis; reported values reflect the dilution.

J Data are estimated due to associated quality control data.

T Analyte was positively identified but the reported concentration is estimated; reported concentration is less than the reporting limit, but greater than the method detection limit.

UJ Potential low bias, possible false negative.

SIM Selective ion monitoring

- Not analyzed

TABLE 3

POLYNUCLEAR AROMATIC HYDROCARBONS SOLID SAMPLE DATA SUMMARY
DEMONSTRATION TESTING AND FULL-SCALE OPERATION OF THE BIOGENESIS SEDIMENT DECONTAMINATION PROCESS
KEASBEY, NEW JERSEY
 (Page 40 of 67)

Field Sample Identification	WS-120406-1840	PSS-130406-1700	SS1-130406-1705	SS2-130406-1710	RS-130406-1715	TS-130406-1735	TS1-130406-1720
Sediment Source	Arthur Kill	Arthur Kill	Arthur Kill	Arthur Kill	Arthur Kill	Arthur Kill	Arthur Kill
Location Identification	WS	PSS	SS1	SS2	RS	TS	TS1
Date Collected	4/12/06	4/13/06	4/13/06	4/13/06	4/13/06	4/13/06	4/13/06
Matrix	Solid	Solid	Solid	Solid	Solid	Solid	Solid
Analyte/Methods (Units)							
Polynuclear Aromatic Hydrocarbons/SW8270C-SIM (µg/kg)							
Acenaphthene	270 D	310 D	1600 D	1900 D	490 D	160 D	800 D
Acenaphthylene	230 D	440 D	940 D	2200 D	670 D	300 D	1500 D
Anthracene	630 D	940 D	3600 D	4200 D	1200 D	460 D	2200 D
Benzo(a)anthracene	770 D	1500 D	6200 D	8400 D	1800 D	820 D	4100 DJ
Benzo(a)pyrene	620 D	1500 D	4600 D	7900 D	1800 D	820 D	4000 DJ
Benzo(b)fluoranthene	750 DJ	1600 D	5500 D	8600 D	2000 D	960 D	4400 DJ
Benzo(g,h,i)perylene	320 D	1000 D	2800 D	4900 D	1100 D	600 D	2500 D
Benzo(k)fluoranthene	260 D	700 D	2200 D	3300 D	710 D	310 D	1600 DJ
Chrysene	960 D	1500 D	5700 D	9000 D	2000 D	880 D	4400 DJ
Dibenz(a,h)anthracene	100 TD	240 D	790 D	1300 D	300 D	150 D	700 D
Fluoranthene	1700 DJ	2900 D	12000 D	13000 D	3500 D	1400 D	6800 D
Fluorene	160 TDJ	300 D	1700 D	1600 D	580 D	170 D	1100 D
Indeno(1,2,3-c,d)Pyrene	290 DJ	830 D	2500 D	4200 D	960 D	490 D	2200 D
Naphthalene	280 D	400 D	2500 D	1900 D	760 D	260 D	1300 D
Phenanthrene	840 D	1400 D	10000 D	9300 D	2400 D	760 D	5100 DJ
Pyrene	1600 DJ	2800 D	9900 D	14000 D	3500 D	1500 D	6500 D

µg/kg micrograms per kilogram

Bold Bolded result indicates positively identified compound.

B Analyte detected in an associated blank.

D Sample dilution required for analysis; reported values reflect the dilution.

J Data are estimated due to associated quality control data.

T Analyte was positively identified but the reported concentration is estimated; reported concentration is less than the reporting limit, but greater than the method detection limit.

UJ Potential low bias, possible false negative.

SIM Selective ion monitoring

- Not analyzed

TABLE 3

POLYNUCLEAR AROMATIC HYDROCARBONS SOLID SAMPLE DATA SUMMARY
DEMONSTRATION TESTING AND FULL-SCALE OPERATION OF THE BIOGENESIS SEDIMENT DECONTAMINATION PROCESS
KEASBEY, NEW JERSEY
 (Page 41 of 67)

Field Sample Identification	TS2-130406-1725	TS3-130406-1730	WS-130406-1740	PSS-170406-1700	SS1-170406-1715	SS2-170406-1720	RS-170406-1725
Sediment Source	Arthur Kill	Arthur Kill	Arthur Kill	Arthur Kill	Arthur Kill	Arthur Kill	Arthur Kill
Location Identification	TS2	TS3	WS	PSS	SS1	SS2	RS
Date Collected	4/13/06	4/13/06	4/13/06	4/17/06	4/17/06	4/17/06	4/17/06
Matrix	Solid	Solid	Solid	Solid	Solid	Solid	Solid
Analyte/Methods (Units)							
Polynuclear Aromatic Hydrocarbons/SW8270C-SIM (µg/kg)							
Acenaphthene	97 D	140 D	180 D	380 D	1400 D	980 D	300 TD
Acenaphthylene	150 D	260 D	170 D	590 D	430 D	1300 D	430 TD
Anthracene	330 D	410 D	350 D	3700 D	4000 D	2500 D	1100 D
Benzo(a)anthracene	770 D	730 D	430 D	2700 D	6600 D	5300 D	1900 D
Benzo(a)pyrene	690 D	760 D	370 D	2300 D	4700 D	5200 D	1400 D
Benzo(b)fluoranthene	790 D	840 D	450 D	2300 D	5200 D	5300 D	1800 D
Benzo(g,h,i)perylene	500 D	580 D	270 D	1400 D	2800 D	3300 D	1000 D
Benzo(k)fluoranthene	310 D	330 D	180 D	1000 D	1900 D	2600 D	580 D
Chrysene	730 D	840 D	450 D	2600 D	6300 D	5300 D	2500 D
Dibenz(a,h)anthracene	130 D	140 D	67 TD	390 D	770 D	890 D	250 TD
Fluoranthene	1200 D	1200 D	960 D	3200 D	10000 D	8200 D	2600 D
Fluorene	100 D	140 D	130 D	360 D	1700 D	950 D	370 TD
Indeno(1,2,3-c,d)Pyrene	430 D	470 D	210 D	1200 D	2400 D	2800 D	820 D
Naphthalene	140 D	230 D	170 D	400 D	870 D	1100 D	360 TD
Phenanthrene	670 D	630 D	450 D	1700 D	10000 D	6000 D	1500 D
Pyrene	1300 D	1400 D	1100 D	4200 D	12000 D	9100 D	3000 D

µg/kg micrograms per kilogram

Bold Bolded result indicates positively identified compound.

B Analyte detected in an associated blank.

D Sample dilution required for analysis; reported values reflect the dilution.

J Data are estimated due to associated quality control data.

T Analyte was positively identified but the reported concentration is estimated; reported concentration is less than the reporting limit, but greater than the method detection limit.

UJ Potential low bias, possible false negative.

SIM Selective ion monitoring

- Not analyzed

TABLE 3

POLYNUCLEAR AROMATIC HYDROCARBONS SOLID SAMPLE DATA SUMMARY
DEMONSTRATION TESTING AND FULL-SCALE OPERATION OF THE BIOGENESIS SEDIMENT DECONTAMINATION PROCESS
KEASBEY, NEW JERSEY
 (Page 42 of 67)

Field Sample Identification	TS-170406-1745	TS1-170406-1730	TS2-170406-1735	TS3-170406-1740	WS-170406-1745	PSS-180406-1700	SS1-180406-1705
Sediment Source	Arthur Kill	Arthur Kill	Arthur Kill	Arthur Kill	Arthur Kill	Arthur Kill	Arthur Kill
Location Identification	TS	TS1	TS2	TS3	WS	PSS	SS1
Date Collected	4/17/06	4/17/06	4/17/06	4/17/06	4/17/06	4/18/06	4/18/06
Matrix	Solid	Solid	Solid	Solid	Solid	Solid	Solid
Analyte/Methods (Units)							
Polynuclear Aromatic Hydrocarbons/SW8270C-SIM (µg/kg)							
Acenaphthene	240 D	610 D	250 D	220 D	550 D	180 D	1200 D
Acenaphthylene	450 D	930 D	380 D	460 D	420 TD	330 D	1500 D
Anthracene	710 D	1700 D	760 D	670 D	1100 D	520 D	4300 D
Benzo(a)anthracene	1400 D	3600 D	1700 D	1200 D	1300 D	1300 D	7800 D
Benzo(a)pyrene	1400 D	3500 D	1700 D	1300 D	1100 D	1300 D	6600 D
Benzo(b)fluoranthene	1500 D	3900 D	1900 D	1400 D	1500 D	1500 D	7200 D
Benzo(g,h,i)perylene	1000 D	2300 D	1200 D	960 D	820 D	920 D	3700 D
Benzo(k)fluoranthene	580 D	1300 D	740 D	480 D	570 D	550 D	2800 D
Chrysene	1400 D	3600 D	1700 D	1300 D	1400 D	1300 D	7300 D
Dibenz(a,h)anthracene	250 D	610 D	300 D	260 D	210 TD	230 D	1100 D
Fluoranthene	2200 D	5700 D	3100 D	2000 D	2700 D	1700 D	12000 D
Fluorene	250 D	690 D	280 D	240 D	330 TD	170 DJ	1200 DJ
Indeno(1,2,3-c,d)Pyrene	830 D	2000 D	1000 D	770 D	650 D	790 D	3400 D
Naphthalene	360 D	820 D	330 D	350 D	400 TD	210 D	880 D
Phenanthrene	1200 D	4100 D	1800 D	980 D	1500 D	790 D	7600 D
Pyrene	2600 D	6100 D	3000 D	2200 D	3700 D	2400 D	14000 D

µg/kg micrograms per kilogram

Bold Bolded result indicates positively identified compound.

B Analyte detected in an associated blank.

D Sample dilution required for analysis; reported values reflect the dilution.

J Data are estimated due to associated quality control data.

T Analyte was positively identified but the reported concentration is estimated; reported concentration is less than the reporting limit, but greater than the method detection limit.

UJ Potential low bias, possible false negative.

SIM Selective ion monitoring

- Not analyzed

TABLE 3

POLYNUCLEAR AROMATIC HYDROCARBONS SOLID SAMPLE DATA SUMMARY
DEMONSTRATION TESTING AND FULL-SCALE OPERATION OF THE BIOGENESIS SEDIMENT DECONTAMINATION PROCESS
KEASBEY, NEW JERSEY
 (Page 43 of 67)

Field Sample Identification	SS2-180406-1710	RS-180406-1715	TS-180406-1735	TS1-180406-1720	TS2-180406-1725	TS3-180406-1730	WS-180406-1740
Sediment Source	Arthur Kill	Arthur Kill	Arthur Kill	Arthur Kill	Arthur Kill	Arthur Kill	Arthur Kill
Location Identification	SS2	RS	TS	TS1	TS2	TS3	WS
Date Collected	4/18/06	4/18/06	4/18/06	4/18/06	4/18/06	4/18/06	4/18/06
Matrix	Solid	Solid	Solid	Solid	Solid	Solid	Solid
Analyte/Methods (Units)							
Polynuclear Aromatic Hydrocarbons/SW8270C-SIM (µg/kg)							
Acenaphthene	1200 D	89 TD	95 D	630 D	110 D	93 D	85 TD
Acenaphthylene	1300 D	170 D	150 D	1000 D	190 D	160 D	73 TD
Anthracene	3000 D	300 D	290 D	2100 DJ	360 D	300 D	170 D
Benzo(a)anthracene	6600 D	650 D	640 D	4000 DJ	860 D	540 D	210 D
Benzo(a)pyrene	6100 D	590 D	640 D	4200 D	950 D	560 D	180 D
Benzo(b)fluoranthene	6500 D	700 D	660 D	4400 DJ	1000 D	590 D	220 D
Benzo(g,h,i)perylene	3700 D	430 D	480 D	2800 D	700 D	440 D	140 D
Benzo(k)fluoranthene	2600 D	230 D	300 D	1900 D	440 D	260 D	82 TD
Chrysene	6000 D	600 D	660 D	4100 DJ	900 D	580 D	210 D
Dibenz(a,h)anthracene	1000 D	110 TD	120 D	820 D	190 D	110 D	35 TD
Fluoranthene	8800 D	1200 D	1000 D	5500 D	1300 D	840 D	440 D
Fluorene	1200 DJ	96 TDJ	96 DJ	670 DJ	120 DJ	89 DJ	65 TDJ
Indeno(1,2,3-c,d)Pyrene	3300 D	340 D	400 D	2500 D	610 D	350 D	110 TD
Naphthalene	1300 D	110 TD	110 D	650 D	95 D	150 D	68 TD
Phenanthrene	6700 D	430 D	660 D	4500 DJ	780 D	480 D	220 D
Pyrene	12000 D	1400 D	1100 D	6700 D	1700 D	1100 D	600 D

µg/kg micrograms per kilogram

Bold Bolded result indicates positively identified compound.

B Analyte detected in an associated blank.

D Sample dilution required for analysis; reported values reflect the dilution.

J Data are estimated due to associated quality control data.

T Analyte was positively identified but the reported concentration is estimated; reported concentration is less than the reporting limit, but greater than the method detection limit.

UJ Potential low bias, possible false negative.

SIM Selective ion monitoring

- Not analyzed

TABLE 3

POLYNUCLEAR AROMATIC HYDROCARBONS SOLID SAMPLE DATA SUMMARY
DEMONSTRATION TESTING AND FULL-SCALE OPERATION OF THE BIOGENESIS SEDIMENT DECONTAMINATION PROCESS
KEASBEY, NEW JERSEY
 (Page 44 of 67)

Field Sample Identification	PSS-190406-0900	SS1-190406-0905	SS2-190406-0910	RS-190406-0915	TS-190406-0845	TS1-190406-0845	TS2-190406-0845
Sediment Source	Arthur Kill	Arthur Kill	Arthur Kill	Arthur Kill	Arthur Kill	Arthur Kill	Arthur Kill
Location Identification	PSS	SS1	SS2	RS	TS	TS1	TS2
Date Collected	4/19/06	4/19/06	4/19/06	4/19/06	4/19/06	4/19/06	4/19/06
Matrix	Solid	Solid	Solid	Solid	Solid	Solid	Solid
Analyte/Methods (Units)							
Polynuclear Aromatic Hydrocarbons/SW8270C-SIM (µg/kg)							
Acenaphthene	250 TD	1100 D	1500 D	230 TD	270 D	1100 D	140 D
Acenaphthylene	420 D	1400 D	2400 D	450 D	470 D	1500 D	260 D
Anthracene	750 D	3800 D	4700 D	630 D	790 D	3100 D	440 D
Benzo(a)anthracene	1300 D	6300 D	7000 D	1100 D	1600 D	6100 D	1100 D
Benzo(a)pyrene	1400 D	4900 D	6300 D	1100 D	1600 D	5500 D	1100 D
Benzo(b)fluoranthene	1400 D	5400 D	6100 D	1200 D	1800 D	5900 D	1300 D
Benzo(g,h,i)perylene	1100 D	3000 D	4100 D	900 D	1200 D	4100 D	870 D
Benzo(k)fluoranthene	650 D	2000 D	2800 D	470 D	650 D	2200 D	390 D
Chrysene	1400 D	6100 D	8000 D	1100 D	1700 D	5700 D	1100 D
Dibenz(a,h)anthracene	290 D	860 D	1200 D	220 TD	320 D	1100 D	220 D
Fluoranthene	2100 D	9700 D	9100 D	1700 D	2600 D	9900 D	1600 D
Fluorene	230 TDJ	920 DJ	2100 DJ	220 TDJ	260 DJ	1000 DJ	140 DJ
Indeno(1,2,3-c,d)Pyrene	870 D	2600 D	3500 D	720 D	1000 D	3500 D	740 D
Naphthalene	260 D	780 D	4000 D	250 TD	350 D	1200 D	170 D
Phenanthrene	1200 D	6400 D	9000 D	810 D	1500 D	7000 D	890 D
Pyrene	2600 D	10000 D	11000 D	2100 D	2600 D	7800 D	1900 D

µg/kg micrograms per kilogram

Bold Bolded result indicates positively identified compound.

B Analyte detected in an associated blank.

D Sample dilution required for analysis; reported values reflect the dilution.

J Data are estimated due to associated quality control data.

T Analyte was positively identified but the reported concentration is estimated; reported concentration is less than the reporting limit, but greater than the method detection limit.

UJ Potential low bias, possible false negative.

SIM Selective ion monitoring

- Not analyzed

TABLE 3

POLYNUCLEAR AROMATIC HYDROCARBONS SOLID SAMPLE DATA SUMMARY
DEMONSTRATION TESTING AND FULL-SCALE OPERATION OF THE BIOGENESIS SEDIMENT DECONTAMINATION PROCESS
KEASBEY, NEW JERSEY
 (Page 45 of 67)

Field Sample Identification	TS3-190406-0845	WS-190406-1600	PSS-200406-1600	SS1-200406-1605	SS2-200406-1610	RS-200406-1615	TS-200406-1635
Sediment Source	Arthur Kill	Arthur Kill	Arthur Kill	Arthur Kill	Arthur Kill	Arthur Kill	Arthur Kill
Location Identification	TS3	WS	PSS	SS1	SS2	RS	TS
Date Collected	4/19/06	4/19/06	4/20/06	4/20/06	4/20/06	4/20/06	4/20/06
Matrix	Solid	Solid	Solid	Solid	Solid	Solid	Solid
Analyte/Methods (Units)							
Polynuclear Aromatic Hydrocarbons/SW8270C-SIM (µg/kg)							
Acenaphthene	210 D	160 D	180 D	1600 D	860 D	210 D	210 D
Acenaphthylene	220 D	120 D	330 D	2200 D	1400 D	400 D	410 D
Anthracene	430 D	290 D	630 D	6300 D	2400 D	690 D	710 D
Benzo(a)anthracene	960 D	370 D	1100 D	10000 D	6100 D	1100 D	1500 DJ
Benzo(a)pyrene	1100 D	310 D	1100 D	7500 D	5700 D	1100 D	1400 DJ
Benzo(b)fluoranthene	1200 D	390 D	1100 D	7200 D	5700 D	1300 D	1600 DJ
Benzo(g,h,i)perylene	850 D	230 D	770 D	4200 D	3700 D	850 D	1100 D
Benzo(k)fluoranthene	420 D	140 D	490 D	3400 D	2500 D	410 D	550 D
Chrysene	1000 D	360 D	1300 D	9600 D	5600 D	1300 D	1400 D
Dibenz(a,h)anthracene	210 D	59 TD	220 D	1300 D	990 D	210 D	270 D
Fluoranthene	1500 D	700 D	1700 D	15000 D	7800 D	1900 D	2300 DJ
Fluorene	140 DJ	91 TDJ	170 D	1900 D	810 D	200 D	210 D
Indeno(1,2,3-c,d)Pyrene	700 D	190 D	640 D	3700 D	3200 D	680 D	900 D
Naphthalene	180 D	120 D	200 D	1700 D	1000 D	260 D	320 DJ
Phenanthrene	820 D	380 D	870 D	13000 D	5000 D	900 D	1200 DJ
Pyrene	1700 D	950 D	2000 D	17000 D	8800 D	2200 D	2300 DJ

µg/kg micrograms per kilogram

Bold Bolded result indicates positively identified compound.

B Analyte detected in an associated blank.

D Sample dilution required for analysis; reported values reflect the dilution.

J Data are estimated due to associated quality control data.

T Analyte was positively identified but the reported concentration is estimated; reported concentration is less than the reporting limit, but greater than the method detection limit.

UJ Potential low bias, possible false negative.

SIM Selective ion monitoring

- Not analyzed

TABLE 3

POLYNUCLEAR AROMATIC HYDROCARBONS SOLID SAMPLE DATA SUMMARY
DEMONSTRATION TESTING AND FULL-SCALE OPERATION OF THE BIOGENESIS SEDIMENT DECONTAMINATION PROCESS
KEASBEY, NEW JERSEY
 (Page 46 of 67)

Field Sample Identification	TS1-200406-1620	TS2-200406-1625	TS3-200406-1630	WS-200406-1640	PSS-210406-1400	SS1-210406-1405	SS2-210406-1410
Sediment Source	Arthur Kill	Arthur Kill	Arthur Kill	Arthur Kill	Arthur Kill	Arthur Kill	Arthur Kill
Location Identification	TS1	TS2	TS3	WS	PSS	SS1	SS2
Date Collected	4/20/06	4/20/06	4/20/06	4/20/06	4/21/06	4/21/06	4/21/06
Matrix	Solid	Solid	Solid	Solid	Solid	Solid	Solid
Analyte/Methods (Units)							
Polynuclear Aromatic Hydrocarbons/SW8270C-SIM (µg/kg)							
Acenaphthene	990 D	140 D	120 D	130 D	290 D	1300 D	760 D
Acenaphthylene	1600 D	270 D	220 D	120 D	500 D	1500 D	2300 D
Anthracene	3000 D	460 D	360 D	310 D	860 D	5100 D	6500 D
Benzo(a)anthracene	6800 D	1100 D	640 D	350 D	1600 D	11000 D	6600 D
Benzo(a)pyrene	6200 D	1100 D	650 D	320 D	1600 D	9300 D	5800 D
Benzo(b)fluoranthene	6800 D	1200 D	710 D	420 D	1700 D	9700 D	6400 D
Benzo(g,h,i)perylene	4300 D	770 D	500 D	230 D	1100 D	5800 D	3700 D
Benzo(k)fluoranthene	2200 D	440 D	280 D	160 D	740 D	4300 D	2700 D
Chrysene	6100 D	1100 D	700 D	400 D	1700 D	11000 D	6800 D
Dibenz(a,h)anthracene	1100 D	190 D	130 D	50 TD	270 D	1700 D	950 D
Fluoranthene	10000 D	1800 D	1100 D	830 D	2800 D	19000 D	11000 D
Fluorene	1100 D	150 D	110 D	92 TD	290 D	1200 D	1600 D
Indeno(1,2,3-c,d)Pyrene	3700 D	660 D	400 D	160 D	880 D	5300 D	3200 D
Naphthalene	1200 D	180 D	190 D	100 TD	390 D	730 D	1400 D
Phenanthrene	7900 D	930 D	520 D	360 D	1400 D	9600 D	5900 D
Pyrene	11000 D	1800 D	1100 D	870 D	2900 D	16000 D	11000 D

µg/kg micrograms per kilogram

Bold Bolded result indicates positively identified compound.

B Analyte detected in an associated blank.

D Sample dilution required for analysis; reported values reflect the dilution.

J Data are estimated due to associated quality control data.

T Analyte was positively identified but the reported concentration is estimated; reported concentration is less than the reporting limit, but greater than the method detection limit.

UJ Potential low bias, possible false negative.

SIM Selective ion monitoring

- Not analyzed

TABLE 3

POLYNUCLEAR AROMATIC HYDROCARBONS SOLID SAMPLE DATA SUMMARY
DEMONSTRATION TESTING AND FULL-SCALE OPERATION OF THE BIOGENESIS SEDIMENT DECONTAMINATION PROCESS
KEASBEY, NEW JERSEY
 (Page 47 of 67)

Field Sample Identification	RS-210406-1415	TS-210406-1435	TS1-210406-1420	TS2-210406-1425	TS3-210406-1430	WS-210406-1440	PSS-240406-1600
Sediment Source	Arthur Kill	Arthur Kill	Arthur Kill	Arthur Kill	Arthur Kill	Arthur Kill	Arthur Kill
Location Identification	RS	TS	TS1	TS2	TS3	WS	PSS
Date Collected	4/21/06	4/21/06	4/21/06	4/21/06	4/21/06	4/21/06	4/24/06
Matrix	Solid	Solid	Solid	Solid	Solid	Solid	Solid
Analyte/Methods (Units)							
Polynuclear Aromatic Hydrocarbons/SW8270C-SIM (µg/kg)							
Acenaphthene	280 D	160 D	770 D	110 D	100 D	120 D	250 TD
Acenaphthylene	420 D	340 D	1100 D	220 D	200 D	110 D	360 D
Anthracene	750 D	500 D	2100 DJ	380 D	320 D	240 D	780 D
Benzo(a)anthracene	1200 D	950 D	4400 DJ	900 D	610 D	290 D	1500 D
Benzo(a)pyrene	1200 D	1000 D	4100 DJ	900 D	610 D	250 D	1300 D
Benzo(b)fluoranthene	1500 D	1100 D	4300 D	1000 D	640 D	320 D	1500 D
Benzo(g,h,i)perylene	910 D	760 D	2800 D	670 D	480 D	190 D	950 D
Benzo(k)fluoranthene	600 D	490 D	1900 D	390 D	280 D	100 TD	530 D
Chrysene	1300 D	1000 D	4300 DJ	930 D	670 D	330 D	1400 D
Dibenz(a,h)anthracene	220 D	190 D	730 D	160 D	120 D	44 TD	220 TD
Fluoranthene	2300 D	1700 D	7700 D	1700 D	1100 D	640 D	2600 D
Fluorene	250 D	170 D	830 D	120 D	110 D	93 TD	250 TD
Indeno(1,2,3-c,d)Pyrene	730 D	630 D	2400 D	590 D	400 D	140 D	770 D
Naphthalene	320 D	210 D	720 D	110 D	150 D	87 TD	330 D
Phenanthrene	1100 D	850 D	5500 D	860 D	470 D	300 D	1300 D
Pyrene	2200 D	1500 D	6500 D	1500 D	960 D	730 D	2800 D

µg/kg micrograms per kilogram

Bold Bolded result indicates positively identified compound.

B Analyte detected in an associated blank.

D Sample dilution required for analysis; reported values reflect the dilution.

J Data are estimated due to associated quality control data.

T Analyte was positively identified but the reported concentration is estimated; reported concentration is less than the reporting limit, but greater than the method detection limit.

UJ Potential low bias, possible false negative.

SIM Selective ion monitoring

- Not analyzed

TABLE 3

POLYNUCLEAR AROMATIC HYDROCARBONS SOLID SAMPLE DATA SUMMARY
DEMONSTRATION TESTING AND FULL-SCALE OPERATION OF THE BIOGENESIS SEDIMENT DECONTAMINATION PROCESS
KEASBEY, NEW JERSEY
 (Page 48 of 67)

Field Sample Identification	SS1-240406-1605	SS2-240406-1610	RS-240406-1615	INF1-250406-1845	INF1-260406-1345	TS-240406-1635	TS1-240406-1620
Sediment Source	Arthur Kill	Arthur Kill	Arthur Kill	Arthur Kill	Arthur Kill	Arthur Kill	Arthur Kill
Location Identification	SS1	SS2	RS	RS Dup	RS Dup	TS	TS1
Date Collected	4/24/06	4/24/06	4/24/06	4/24/06	4/24/06	4/24/06	4/24/06
Matrix	Solid	Solid	Solid	Solid	Solid	Solid	Solid
Analyte/Methods (Units)							
Polynuclear Aromatic Hydrocarbons/SW8270C-SIM (µg/kg)							
Acenaphthene	1800 D	1200 D	190 TD	260 D	230 D	140 D	810 D
Acenaphthylene	1900 D	2000 D	270 D	440 D	380 D	260 D	1400 D
Anthracene	6400 D	3700 D	490 D	760 D	700 D	440 D	3100 D
Benzo(a)anthracene	11000 D	7500 D	910 D	1200 D	1300 D	890 D	6300 DJ
Benzo(a)pyrene	9100 D	6400 D	910 D	1200 D	1300 D	830 D	5600 D
Benzo(b)fluoranthene	11000 D	6800 D	950 D	1300 D	1400 D	880 D	6200 DJ
Benzo(g,h,i)perylene	5200 D	4100 D	660 D	910 D	940 D	620 D	3700 DJ
Benzo(k)fluoranthene	4000 D	2900 D	450 D	520 D	570 D	380 D	2200 DJ
Chrysene	12000 D	8500 D	980 D	1300 D	1400 D	910 D	6000 D
Dibenz(a,h)anthracene	1500 D	1100 D	160 TD	250 D	230 D	150 D	980 D
Fluoranthene	22000 D	12000 D	1600 D	2200 D	2200 D	1400 D	9000 D
Fluorene	1800 D	1400 D	170 TD	260 D	230 D	150 D	940 D
Indeno(1,2,3-c,d)Pyrene	4800 D	3600 D	540 D	750 D	780 D	510 D	3300 DJ
Naphthalene	920 D	1500 D	250 D	290 D	240 D	240 D	1100 D
Phenanthrene	13000 D	8300 D	770 D	1000 D	1200 D	740 D	6100 D
Pyrene	21000 D	12000 D	1700 D	2200 D	2200 D	1400 D	8900 D

µg/kg micrograms per kilogram

Bold Bolded result indicates positively identified compound.

B Analyte detected in an associated blank.

D Sample dilution required for analysis; reported values reflect the dilution.

J Data are estimated due to associated quality control data.

T Analyte was positively identified but the reported concentration is estimated; reported concentration is less than the reporting limit, but greater than the method detection limit.

UJ Potential low bias, possible false negative.

SIM Selective ion monitoring

- Not analyzed

TABLE 3

POLYNUCLEAR AROMATIC HYDROCARBONS SOLID SAMPLE DATA SUMMARY
DEMONSTRATION TESTING AND FULL-SCALE OPERATION OF THE BIOGENESIS SEDIMENT DECONTAMINATION PROCESS
KEASBEY, NEW JERSEY
 (Page 49 of 67)

Field Sample Identification	TS2-240406-1625	TS3-240406-1630	WS-240406-1640	PSS-250406-1800	SS2-250406-1810	RS-250406-1815	TS-250406-1835
Sediment Source	Arthur Kill	Arthur Kill	Arthur Kill	Arthur Kill	Arthur Kill	Arthur Kill	Arthur Kill
Location Identification	TS2	TS3	WS	PSS	SS2	RS	TS
Date Collected	4/24/06	4/24/06	4/24/06	4/25/06	4/25/06	4/25/06	4/25/06
Matrix	Solid	Solid	Solid	Solid	Solid	Solid	Solid
Analyte/Methods (Units)							
Polynuclear Aromatic Hydrocarbons/SW8270C-SIM (µg/kg)							
Acenaphthene	110 D	140 D	140 D	280 D	9000 D	320 D	150 D
Acenaphthylene	210 D	260 D	140 D	450 D	2500 D	460 D	180 D
Anthracene	390 D	460 D	320 D	810 D	7600 D	860 D	420 D
Benzo(a)anthracene	880 D	860 D	370 D	1500 D	7200 D	1500 D	790 D
Benzo(a)pyrene	860 D	850 D	320 D	1400 D	6000 D	1600 D	780 D
Benzo(b)fluoranthene	1000 D	910 D	400 D	1600 D	5600 D	1800 D	830 D
Benzo(g,h,i)perylene	630 D	640 D	230 D	1000 D	3300 D	1100 D	540 D
Benzo(k)fluoranthene	360 D	360 D	160 D	650 D	2700 D	570 D	370 D
Chrysene	880 D	890 D	390 D	1600 D	6600 D	1700 D	890 D
Dibenz(a,h)anthracene	160 D	170 D	57 TD	240 D	950 D	260 D	150 D
Fluoranthene	1600 D	1400 D	840 D	2300 D	11000 D	2600 D	1300 D
Fluorene	120 D	140 D	110 TD	290 D	5600 D	310 D	170 D
Indeno(1,2,3-c,d)Pyrene	550 D	530 D	190 D	830 D	2800 D	910 D	450 D
Naphthalene	100 D	240 D	120 D	320 D	2900 D	390 D	170 D
Phenanthrene	790 D	690 D	410 D	1400 D	20000 D	1400 D	1000 D
Pyrene	1500 D	1400 D	880 D	2600 D	13000 D	2900 D	1400 D

µg/kg micrograms per kilogram

Bold Bolded result indicates positively identified compound.

B Analyte detected in an associated blank.

D Sample dilution required for analysis; reported values reflect the dilution.

J Data are estimated due to associated quality control data.

T Analyte was positively identified but the reported concentration is estimated; reported concentration is less than the reporting limit, but greater than the method detection limit.

UJ Potential low bias, possible false negative.

SIM Selective ion monitoring

- Not analyzed

TABLE 3

POLYNUCLEAR AROMATIC HYDROCARBONS SOLID SAMPLE DATA SUMMARY
DEMONSTRATION TESTING AND FULL-SCALE OPERATION OF THE BIOGENESIS SEDIMENT DECONTAMINATION PROCESS
KEASBEY, NEW JERSEY
 (Page 50 of 67)

Field Sample Identification	TS1-250406-1820	TS2-250406-1825	TS3-250406-1830	WS-250406-1840	PSS-260406-1300	SS1-260406-1305	SS2-260406-1310
Sediment Source	Arthur Kill	Arthur Kill	Arthur Kill	Arthur Kill	Arthur Kill	Arthur Kill	Arthur Kill
Location Identification	TS1	TS2	TS3	WS	PSS	SS1	SS2
Date Collected	4/25/06	4/25/06	4/25/06	4/25/06	4/26/06	4/26/06	4/26/06
Matrix	Solid	Solid	Solid	Solid	Solid	Solid	Solid
Analyte/Methods (Units)							
Polynuclear Aromatic Hydrocarbons/SW8270C-SIM (µg/kg)							
Acenaphthene	790 D	98 D	130 D	110 D	230 D	200 D	340 D
Acenaphthylene	1400 D	190 D	220 D	110 D	270 D	220 D	590 D
Anthracene	2400 D	330 D	360 D	220 D	670 D	510 D	8300 D
Benzo(a)anthracene	5100 D	810 D	700 D	280 D	1200 D	680 D	2900 D
Benzo(a)pyrene	4900 D	830 D	730 D	270 D	1200 D	620 D	2500 D
Benzo(b)fluoranthene	5400 D	1000 D	830 D	350 D	1300 D	590 D	2700 D
Benzo(g,h,i)perylene	3200 D	570 D	530 D	190 D	850 D	430 D	1500 D
Benzo(k)fluoranthene	2100 D	430 D	290 D	100 TD	600 D	230 D	1200 D
Chrysene	5000 D	890 D	750 D	330 D	1300 D	760 D	2600 D
Dibenz(a,h)anthracene	840 D	140 D	130 D	47 TD	210 D	140 TD	390 D
Fluoranthene	8300 D	1400 D	1200 D	600 DJ	2200 D	1300 D	4000 D
Fluorene	950 D	120 D	130 D	90 TD	220 D	270 D	870 D
Indeno(1,2,3-c,d)Pyrene	2800 D	500 D	430 D	150 D	700 D	300 D	1300 D
Naphthalene	1100 D	110 D	180 D	94 TD	310 D	410 D	750 D
Phenanthrene	6100 D	720 D	590 D	340 DJ	1200 D	1200 D	3700 D
Pyrene	8000 D	1400 D	1300 D	730 D	2300 D	1700 D	4300 D

µg/kg micrograms per kilogram

Bold Bolded result indicates positively identified compound.

B Analyte detected in an associated blank.

D Sample dilution required for analysis; reported values reflect the dilution.

J Data are estimated due to associated quality control data.

T Analyte was positively identified but the reported concentration is estimated; reported concentration is less than the reporting limit, but greater than the method detection limit.

UJ Potential low bias, possible false negative.

SIM Selective ion monitoring

- Not analyzed

TABLE 3

POLYNUCLEAR AROMATIC HYDROCARBONS SOLID SAMPLE DATA SUMMARY
DEMONSTRATION TESTING AND FULL-SCALE OPERATION OF THE BIOGENESIS SEDIMENT DECONTAMINATION PROCESS
KEASBEY, NEW JERSEY
 (Page 51 of 67)

Field Sample Identification	RS-260406-1315	TS-260406-1335	TS1-260406-1320	TS2-260406-1325	TS3-260406-1330	WS-260406-1340	PSS-270406-1700
Sediment Source	Arthur Kill	Arthur Kill	Arthur Kill	Arthur Kill	Arthur Kill	Arthur Kill	Arthur Kill
Location Identification	RS	TS	TS1	TS2	TS3	WS	PSS
Date Collected	4/26/06	4/26/06	4/26/06	4/26/06	4/26/06	4/26/06	4/27/06
Matrix	Solid	Solid	Solid	Solid	Solid	Solid	Solid
Analyte/Methods (Units)							
Polynuclear Aromatic Hydrocarbons/SW8270C-SIM (µg/kg)							
Acenaphthene	240 D	210 D	560 D	85 TD	85 D	150 D	220 TD
Acenaphthylene	320 D	350 D	830 D	160 D	150 D	120 TD	390 D
Anthracene	680 D	660 D	1500 D	290 D	270 D	330 D	690 D
Benzo(a)anthracene	1100 D	1300 D	3500 DJ	680 D	530 D	400 D	1200 D
Benzo(a)pyrene	1100 D	1300 D	3400 DJ	710 D	510 D	360 D	1200 D
Benzo(b)fluoranthene	1300 D	1400 D	3500 DJ	780 D	570 D	440 D	1300 D
Benzo(g,h,i)perylene	790 D	920 D	2200 D	510 D	380 D	260 D	910 D
Benzo(k)fluoranthene	530 D	500 D	1600 DJ	310 D	190 D	160 D	500 D
Chrysene	1200 D	1400 D	3600 DJ	710 D	540 D	420 D	1200 D
Dibenz(a,h)anthracene	190 D	230 D	580 D	130 D	92 D	62 TD	230 TD
Fluoranthene	2000 D	2000 D	5300 D	1100 D	820 D	820 D	2100 D
Fluorene	250 D	210 D	590 D	97 D	88 D	110 TD	220 TD
Indeno(1,2,3-c,d)Pyrene	630 D	770 D	2000 DJ	440 D	310 D	200 D	740 D
Naphthalene	290 D	320 D	550 D	100 D	130 D	140 D	260 D
Phenanthrene	1300 D	1100 D	4000 DJ	580 D	450 D	410 D	1100 D
Pyrene	2200 D	2100 D	5500 D	1200 D	880 D	980 D	2200 D

µg/kg micrograms per kilogram

Bold Bolded result indicates positively identified compound.

B Analyte detected in an associated blank.

D Sample dilution required for analysis; reported values reflect the dilution.

J Data are estimated due to associated quality control data.

T Analyte was positively identified but the reported concentration is estimated; reported concentration is less than the reporting limit, but greater than the method detection limit.

UJ Potential low bias, possible false negative.

SIM Selective ion monitoring

- Not analyzed

TABLE 3

POLYNUCLEAR AROMATIC HYDROCARBONS SOLID SAMPLE DATA SUMMARY
DEMONSTRATION TESTING AND FULL-SCALE OPERATION OF THE BIOGENESIS SEDIMENT DECONTAMINATION PROCESS
KEASBEY, NEW JERSEY
 (Page 52 of 67)

Field Sample Identification	SS1-270406-1705	SS1-270406-1705	SS2-270406-1710	RS-270406-1715	TS-270406-1735	TS1-270406-1720	TS2-270406-1725
Sediment Source	Arthur Kill	Arthur Kill	Arthur Kill	Arthur Kill	Arthur Kill	Arthur Kill	Arthur Kill
Location Identification	SS1	SS1	SS2	RS	TS	TS1	TS2
Date Collected	4/27/06	4/27/06	4/27/06	4/27/06	4/27/06	4/27/06	4/27/06
Matrix	Solid	Solid	Solid	Solid	Solid	Solid	Solid
Analyte/Methods (Units)							
Polynuclear Aromatic Hydrocarbons/SW8270C-SIM (µg/kg)							
Acenaphthene	3800 D	4200 D	1200 D	150 D	170 D	790 D	98 D
Acenaphthylene	5400 D	7700 D	2400 D	180 D	240 D	1200 D	160 D
Anthracene	9900 D	11000 D	4600 D	570 D	600 D	2400 D	390 D
Benzo(a)anthracene	19000 D	17000 D	10000 D	1000 D	1100 D	6500 D	940 D
Benzo(a)pyrene	14000 D	13000 D	7600 D	860 D	1000 D	5500 D	840 D
Benzo(b)fluoranthene	14000 D	12000 D	7600 D	1000 D	1200 D	5600 D	1000 D
Benzo(g,h,i)perylene	7200 D	7800 D	4300 D	580 D	740 D	3600 D	590 D
Benzo(k)fluoranthene	5900 D	4200 D	3300 D	410 D	370 D	2500 D	420 D
Chrysene	20000 D	21000 D	8000 D	930 D	1100 D	5600 D	860 D
Dibenz(a,h)anthracene	2200 D	2300 D	1300 D	150 D	200 D	1000 D	150 D
Fluoranthene	28000 D	27000 D	13000 D	1600 D	1600 D	8600 D	1300 D
Fluorene	9400 D	10000 D	1600 D	140 D	160 D	830 D	110 D
Indeno(1,2,3-c,d)Pyrene	5900 D	6300 D	3800 D	480 D	610 D	3100 D	510 D
Naphthalene	13000 D	12000 D	1800 D	170 D	280 D	1100 D	180 D
Phenanthrene	49000 D	44000 D	11000 D	1100 D	1100 D	6300 D	730 D
Pyrene	40000 D	35000 D	13000 D	1800 D	1800 D	8900 D	1500 D

µg/kg micrograms per kilogram

Bold Bolded result indicates positively identified compound.

B Analyte detected in an associated blank.

D Sample dilution required for analysis; reported values reflect the dilution.

J Data are estimated due to associated quality control data.

T Analyte was positively identified but the reported concentration is estimated; reported concentration is less than the reporting limit, but greater than the method detection limit.

UJ Potential low bias, possible false negative.

SIM Selective ion monitoring

- Not analyzed

TABLE 3

POLYNUCLEAR AROMATIC HYDROCARBONS SOLID SAMPLE DATA SUMMARY
DEMONSTRATION TESTING AND FULL-SCALE OPERATION OF THE BIOGENESIS SEDIMENT DECONTAMINATION PROCESS
KEASBEY, NEW JERSEY
 (Page 53 of 67)

Field Sample Identification	TS3-270406-1730	WS-270406-1740	PSS-280406-1100	SS1-280406-1105	SS2-280406-1110	RS-280406-1115	TS-280406-1135
Sediment Source	Arthur Kill	Arthur Kill	Arthur Kill	Arthur Kill	Arthur Kill	Arthur Kill	Arthur Kill
Location Identification	TS3	WS	PSS	SS1	SS2	RS	TS
Date Collected	4/27/06	4/27/06	4/28/06	4/28/06	4/28/06	4/28/06	4/28/06
Matrix	Solid	Solid	Solid	Solid	Solid	Solid	Solid
Analyte/Methods (Units)							
Polynuclear Aromatic Hydrocarbons/SW8270C-SIM (µg/kg)							
Acenaphthene	130 D	210 D	350 D	1200 D	1600 D	310 D	210 D
Acenaphthylene	190 D	170 D	430 D	1100 D	1500 D	390 D	380 D
Anthracene	460 D	480 D	1000 D	2800 D	4500 D	980 D	660 D
Benzo(a)anthracene	960 D	500 D	1600 D	4600 D	8200 D	1400 D	1100 D
Benzo(a)pyrene	800 D	470 D	1600 D	3900 D	7000 D	1300 D	1100 D
Benzo(b)fluoranthene	870 D	610 D	1800 D	4300 D	7600 D	1500 D	1200 D
Benzo(g,h,i)perylene	580 D	340 D	1100 D	2300 D	4300 D	910 D	870 D
Benzo(k)fluoranthene	380 D	220 D	630 D	1600 D	2900 D	540 D	490 D
Chrysene	850 D	590 D	1800 D	5800 D	7600 D	1500 D	1300 D
Dibenz(a,h)anthracene	140 D	81 TD	270 D	600 D	1100 D	230 D	210 D
Fluoranthene	1300 D	1100 D	3000 D	7300 D	14000 D	2700 D	2000 D
Fluorene	130 D	150 D	350 D	1200 D	1900 D	290 D	230 D
Indeno(1,2,3-c,d)Pyrene	470 D	260 D	930 D	2000 D	3800 D	730 D	700 D
Naphthalene	270 D	180 D	400 D	1200 D	2000 D	390 D	300 D
Phenanthrene	700 D	600 D	1900 D	7100 D	12000 D	1600 D	1100 D
Pyrene	1500 D	1300 D	2900 D	8200 D	12000 D	2600 D	1800 D

µg/kg micrograms per kilogram

Bold Bolded result indicates positively identified compound.

B Analyte detected in an associated blank.

D Sample dilution required for analysis; reported values reflect the dilution.

J Data are estimated due to associated quality control data.

T Analyte was positively identified but the reported concentration is estimated; reported concentration is less than the reporting limit, but greater than the method detection limit.

UJ Potential low bias, possible false negative.

SIM Selective ion monitoring

- Not analyzed

TABLE 3

POLYNUCLEAR AROMATIC HYDROCARBONS SOLID SAMPLE DATA SUMMARY
DEMONSTRATION TESTING AND FULL-SCALE OPERATION OF THE BIOGENESIS SEDIMENT DECONTAMINATION PROCESS
KEASBEY, NEW JERSEY
 (Page 54 of 67)

Field Sample Identification	TS1-280406-1120	TS1GRAB-280406-0800	TS1GRAB-280406-1100	TS2-280406-1125	TS2GRAB-280406-0805	TS2GRAB-280406-1105	TS3-280406-1130
Sediment Source	Arthur Kill	Arthur Kill	Arthur Kill	Arthur Kill	Arthur Kill	Arthur Kill	Arthur Kill
Location Identification	TS1	TS1	TS1	TS2	TS2	TS2	TS3
Date Collected	4/28/06	4/28/06	4/28/06	4/28/06	4/28/06	4/28/06	4/28/06
Matrix	Solid	Solid	Solid	Solid	Solid	Solid	Solid
Analyte/Methods (Units)							
Polynuclear Aromatic Hydrocarbons/SW8270C-SIM (µg/kg)							
Acenaphthene	620 D	620 D	1300 D	120 D	120 D	130 D	130 D
Acenaphthylene	870 D	1100 D	1500 D	240 D	220 D	220 D	240 D
Anthracene	1700 D	1900 D	3000 D	440 D	420 D	430 D	390 D
Benzo(a)anthracene	3900 DJ	4000 D	5600 D	950 D	900 D	900 D	740 D
Benzo(a)pyrene	3300 D	3900 D	5100 D	920 D	850 D	910 D	710 D
Benzo(b)fluoranthene	3400 D	3900 D	5500 D	1100 D	920 D	1000 D	790 D
Benzo(g,h,i)perylene	2200 D	2800 D	3500 D	690 D	660 D	710 D	540 D
Benzo(k)fluoranthene	1500 D	1800 D	2000 D	460 D	400 D	370 D	270 D
Chrysene	3600 D	3900 D	5600 D	960 D	900 D	950 D	740 D
Dibenz(a,h)anthracene	660 D	780 D	950 D	170 D	160 D	170 D	140 D
Fluoranthene	5600 D	6300 D	9800 D	1800 D	1500 D	1700 D	1100 D
Fluorene	620 D	710 D	1300 D	140 D	130 D	140 D	130 D
Indeno(1,2,3-c,d)Pyrene	1900 D	2400 D	3100 D	580 D	550 D	600 D	440 D
Naphthalene	750 D	770 D	1300 D	170 D	160 D	170 D	210 D
Phenanthrene	4100 D	4700 D	8300 D	850 D	810 D	860 D	580 D
Pyrene	5200 D	5700 D	8100 D	1500 D	1400 D	1400 D	1100 D

µg/kg micrograms per kilogram

Bold Bolded result indicates positively identified compound.

B Analyte detected in an associated blank.

D Sample dilution required for analysis; reported values reflect the dilution.

J Data are estimated due to associated quality control data.

T Analyte was positively identified but the reported concentration is estimated; reported concentration is less than the reporting limit, but greater than the method detection limit.

UJ Potential low bias, possible false negative.

SIM Selective ion monitoring

- Not analyzed

TABLE 3

POLYNUCLEAR AROMATIC HYDROCARBONS SOLID SAMPLE DATA SUMMARY
DEMONSTRATION TESTING AND FULL-SCALE OPERATION OF THE BIOGENESIS SEDIMENT DECONTAMINATION PROCESS
KEASBEY, NEW JERSEY
 (Page 55 of 67)

Field Sample Identification	TS3GRAB-280406-0810	TS3GRAB-280406-1110	TSGRAB-280406-0815	TSGRAB-280406-1115	WS-280406-1140	PSS-010506-1600	SS1-010506-1605
Sediment Source	Arthur Kill	Arthur Kill	Arthur Kill	Arthur Kill	Arthur Kill	Lower Passaic River	Lower Passaic River
Location Identification	TS3	TS3	TS	TS	WS	PSS	SS1
Date Collected	4/28/06	4/28/06	4/28/06	4/28/06	4/28/06	5/1/06	5/1/06
Matrix	Solid	Solid	Solid	Solid	Solid	Solid	Solid
Analyte/Methods (Units)							
Polynuclear Aromatic Hydrocarbons/SW8270C-SIM (µg/kg)							
Acenaphthene	150 D	210 D	200 D	230 D	170 D	200 TD	420 D
Acenaphthylene	280 D	430 D	410 D	410 D	160 D	370 D	750 D
Anthracene	490 D	760 D	660 D	760 D	410 D	790 D	1500 D
Benzo(a)anthracene	780 D	1100 D	1100 D	1300 D	460 D	2100 D	4700 D
Benzo(a)pyrene	760 D	1200 D	1100 D	1300 D	380 D	2100 D	3700 D
Benzo(b)fluoranthene	840 D	1300 D	1200 D	1400 D	480 D	2500 D	4100 D
Benzo(g,h,i)perylene	600 D	940 D	870 D	1000 D	280 D	1600 D	2600 D
Benzo(k)fluoranthene	280 D	480 D	540 D	480 D	150 D	1100 D	1600 D
Chrysene	850 D	1200 D	1200 D	1400 D	470 D	2500 D	5100 D
Dibenz(a,h)anthracene	150 D	250 D	210 D	250 D	67 TD	370 D	690 D
Fluoranthene	1400 D	1900 D	2000 D	2300 D	1100 D	3600 D	5300 D
Fluorene	150 D	230 D	210 D	230 D	130 D	250 TD	400 D
Indeno(1,2,3-c,d)Pyrene	480 D	750 D	700 D	830 D	220 D	1300 D	2000 D
Naphthalene	240 D	340 D	320 D	420 D	150 D	250 TD	280 TD
Phenanthrene	680 D	1000 D	990 D	1100 D	480 D	1700 D	2000 D
Pyrene	1200 D	1700 D	1700 D	2000 D	1000 D	3800 D	6300 D

µg/kg micrograms per kilogram

Bold Bolded result indicates positively identified compound.

B Analyte detected in an associated blank.

D Sample dilution required for analysis; reported values reflect the dilution.

J Data are estimated due to associated quality control data.

T Analyte was positively identified but the reported concentration is estimated; reported concentration is less than the reporting limit, but greater than the method detection limit.

UJ Potential low bias, possible false negative.

SIM Selective ion monitoring

- Not analyzed

TABLE 3

POLYNUCLEAR AROMATIC HYDROCARBONS SOLID SAMPLE DATA SUMMARY
DEMONSTRATION TESTING AND FULL-SCALE OPERATION OF THE BIOGENESIS SEDIMENT DECONTAMINATION PROCESS
KEASBEY, NEW JERSEY
 (Page 56 of 67)

Field Sample Identification	SS2-010506-1610	RS-010506-1615	TS-010506-1635	TS1-010506-1620	TS2-010506-1625	TS3-010506-1630	WS-010506-1640
Sediment Source	Lower Passaic River	Lower Passaic River	Lower Passaic River	Lower Passaic River	Lower Passaic River	Lower Passaic River	Lower Passaic River
Location Identification	SS2	RS	TS	TS1	TS2	TS3	WS
Date Collected	5/1/06	5/1/06	5/1/06	5/1/06	5/1/06	5/1/06	5/1/06
Matrix	Solid	Solid	Solid	Solid	Solid	Solid	Solid
Analyte/Methods (Units)							
Polynuclear Aromatic Hydrocarbons/SW8270C-SIM (µg/kg)							
Acenaphthene	630 TD	130 TD	190 D	580 D	290 D	180 TD	130 D
Acenaphthylene	1400 D	290 D	300 D	950 D	520 D	280 D	130 D
Anthracene	3100 D	550 D	670 D	1800 D	1100 D	650 D	350 D
Benzo(a)anthracene	7500 D	1400 D	1600 D	4200 D	2800 D	1400 D	540 D
Benzo(a)pyrene	6200 D	1500 D	1500 D	4200 D	2800 D	1500 D	480 D
Benzo(b)fluoranthene	6900 D	1900 D	1800 D	4300 D	3100 D	1700 D	630 D
Benzo(g,h,i)perylene	4000 D	1300 D	1200 D	3000 D	2100 D	1300 D	430 D
Benzo(k)fluoranthene	3100 D	650 D	640 D	1500 D	1100 D	700 D	280 D
Chrysene	7900 D	1800 D	1800 D	4300 D	3100 D	1800 D	680 D
Dibenz(a,h)anthracene	1100 D	290 D	290 D	820 D	510 D	290 D	96 TD
Fluoranthene	9500 D	2500 D	2600 D	5700 D	4300 D	2400 D	1100 D
Fluorene	710 D	180 TD	200 D	610 D	330 D	210 D	110 TD
Indeno(1,2,3-c,d)Pyrene	3300 D	1000 D	990 D	2400 D	1700 D	980 D	330 D
Naphthalene	550 TD	160 TD	230 D	710 D	290 D	240 D	110 TD
Phenanthrene	4900 D	1100 D	1400 D	4000 D	2700 D	1300 D	460 D
Pyrene	10000 D	2700 D	2600 D	6800 D	4600 D	2900 DJ	1300 D

µg/kg micrograms per kilogram

Bold Bolded result indicates positively identified compound.

B Analyte detected in an associated blank.

D Sample dilution required for analysis; reported values reflect the dilution.

J Data are estimated due to associated quality control data.

T Analyte was positively identified but the reported concentration is estimated; reported concentration is less than the reporting limit, but greater than the method detection limit.

UJ Potential low bias, possible false negative.

SIM Selective ion monitoring

- Not analyzed

TABLE 3

POLYNUCLEAR AROMATIC HYDROCARBONS SOLID SAMPLE DATA SUMMARY
DEMONSTRATION TESTING AND FULL-SCALE OPERATION OF THE BIOGENESIS SEDIMENT DECONTAMINATION PROCESS
KEASBEY, NEW JERSEY
 (Page 57 of 67)

Field Sample Identification	PSS-020506-1600	SS1-020506-1605	SS2-020506-1610	RS-020506-1615	STS-1-020506-1200	STS-2-020506-1500	TS-020506-1635
Sediment Source	Lower Passaic River	Lower Passaic River	Lower Passaic River	Lower Passaic River	Lower Passaic River	Lower Passaic River	Lower Passaic River
Location Identification	PSS	SS1	SS2	RS	TS	TS	TS
Date Collected	5/2/06	5/2/06	5/2/06	5/2/06	5/2/06	5/2/06	5/2/06
Matrix	Solid	Solid	Solid	Solid	Solid	Solid	Solid
Analyte/Methods (Units)							
Polynuclear Aromatic Hydrocarbons/SW8270C-SIM (µg/kg)							
Acenaphthene	230 TD	260 TD	740 D	180 TD	270 D	250 D	300 D
Acenaphthylene	510 D	720 D	4200 D	410 D	670 D	600 D	700 D
Anthracene	840 D	1100 D	3000 D	650 D	1100 D	930 D	1200 D
Benzo(a)anthracene	2000 D	2800 D	12000 D	1600 D	2500 D	2100 D	2800 D
Benzo(a)pyrene	2200 D	2400 D	13000 D	1600 D	2500 D	2200 D	2700 D
Benzo(b)fluoranthene	2600 D	2700 D	9900 D	1900 D	3000 D	2600 D	3100 D
Benzo(g,h,i)perylene	1700 D	1500 D	7500 D	1300 D	2100 D	1900 D	2300 D
Benzo(k)fluoranthene	1000 D	860 D	4300 D	720 D	1100 D	1000 D	1400 D
Chrysene	2400 D	3400 D	12000 D	1900 D	3300 D	2900 D	3500 D
Dibenz(a,h)anthracene	390 D	390 TD	1700 D	300 D	510 D	440 D	580 D
Fluoranthene	3500 D	3300 D	12000 D	2800 D	4500 D	3900 D	4900 D
Fluorene	280 TD	330 TD	870 D	210 D	360 D	310 D	390 D
Indeno(1,2,3-c,d)Pyrene	1400 D	1200 D	5700 D	1100 D	1700 D	1500 D	1800 D
Naphthalene	250 TD	790 D	620 D	170 TD	320 D	290 D	380 D
Phenanthrene	1700 D	1400 D	3600 D	1300 D	2100 D	1700 D	2200 D
Pyrene	3900 D	3900 D	18000 D	2700 D	4000 D	3500 D	4300 D

µg/kg micrograms per kilogram

Bold Bolded result indicates positively identified compound.

B Analyte detected in an associated blank.

D Sample dilution required for analysis; reported values reflect the dilution.

J Data are estimated due to associated quality control data.

T Analyte was positively identified but the reported concentration is estimated; reported concentration is less than the reporting limit, but greater than the method detection limit.

UJ Potential low bias, possible false negative.

SIM Selective ion monitoring

- Not analyzed

TABLE 3

POLYNUCLEAR AROMATIC HYDROCARBONS SOLID SAMPLE DATA SUMMARY
DEMONSTRATION TESTING AND FULL-SCALE OPERATION OF THE BIOGENESIS SEDIMENT DECONTAMINATION PROCESS
KEASBEY, NEW JERSEY
 (Page 58 of 67)

Field Sample Identification	TS1-020506-1620	TS2-020506-1625	TS3-020506-1630	WS-020506-1640	PSS-030506-1600	SS1-030506-1605	SS2-030506-1610
Sediment Source	Lower Passaic River	Lower Passaic River	Lower Passaic River	Lower Passaic River	Lower Passaic River	Lower Passaic River	Lower Passaic River
Location Identification	TS1	TS2	TS3	WS	PSS	SS1	SS2
Date Collected	5/2/06	5/2/06	5/2/06	5/2/06	5/3/06	5/3/06	5/3/06
Matrix	Solid	Solid	Solid	Solid	Solid	Solid	Solid
Analyte/Methods (Units)							
Polynuclear Aromatic Hydrocarbons/SW8270C-SIM (µg/kg)							
Acenaphthene	780 D	140 D	290 D	260 TD	210 D	340 TD	510 TD
Acenaphthylene	2300 D	370 D	580 D	590 D	460 D	520 D	1600 D
Anthracene	2700 D	560 D	880 D	770 D	870 D	920 D	1900 D
Benzo(a)anthracene	7400 DJ	1600 D	2000 D	1400 D	2100 D	2700 D	5600 D
Benzo(a)pyrene	6500 DJ	1500 D	2000 D	1400 D	2000 D	2500 D	5000 D
Benzo(b)fluoranthene	6200 DJ	1600 D	2200 D	2000 D	2500 D	2900 D	5200 D
Benzo(g,h,i)perylene	4100 D	1100 D	1700 D	1300 D	1600 D	1700 D	3300 D
Benzo(k)fluoranthene	2400 D	560 D	1100 D	690 D	930 D	1100 D	2200 D
Chrysene	7700 DJ	1700 D	2500 D	2000 D	2800 D	3100 D	6200 D
Dibenz(a,h)anthracene	1200 D	270 D	460 D	290 TD	370 D	430 TD	890 D
Fluoranthene	9600 DJ	2500 D	3500 D	3100 D	3700 D	4300 D	7700 D
Fluorene	940 D	180 D	340 D	270 TD	260 D	340 TD	640 D
Indeno(1,2,3-c,d)Pyrene	3400 D	920 D	1400 D	1000 D	1300 D	1400 D	2700 D
Naphthalene	630 D	120 D	310 D	220 TD	250 D	360 TD	360 TD
Phenanthrene	5500 D	1300 D	1600 D	1000 D	1800 D	1800 D	3500 D
Pyrene	9800 DJ	2300 D	3400 D	3000 D	3300 D	4300 D	7300 D

µg/kg micrograms per kilogram

Bold Bolded result indicates positively identified compound.

B Analyte detected in an associated blank.

D Sample dilution required for analysis; reported values reflect the dilution.

J Data are estimated due to associated quality control data.

T Analyte was positively identified but the reported concentration is estimated; reported concentration is less than the reporting limit, but greater than the method detection limit.

UJ Potential low bias, possible false negative.

SIM Selective ion monitoring

- Not analyzed

TABLE 3

POLYNUCLEAR AROMATIC HYDROCARBONS SOLID SAMPLE DATA SUMMARY
DEMONSTRATION TESTING AND FULL-SCALE OPERATION OF THE BIOGENESIS SEDIMENT DECONTAMINATION PROCESS
KEASBEY, NEW JERSEY
 (Page 59 of 67)

Field Sample Identification	RS-030506-1615	STS-3-030506-1200	STS-4-030506-1400	TS-030506-1635	TS1-030506-1620	TS2-030506-1625	TS3-030506-1630
Sediment Source	Lower Passaic River	Lower Passaic River	Lower Passaic River	Lower Passaic River	Lower Passaic River	Lower Passaic River	Lower Passaic River
Location Identification	RS	TS	TS	TS	TS1	TS2	TS3
Date Collected	5/3/06	5/3/06	5/3/06	5/3/06	5/3/06	5/3/06	5/3/06
Matrix	Solid	Solid	Solid	Solid	Solid	Solid	Solid
Analyte/Methods (Units)							
Polynuclear Aromatic Hydrocarbons/SW8270C-SIM (µg/kg)							
Acenaphthene	240 TD	180 D	210 D	160 D	1200 D	98 D	170 D
Acenaphthylene	570 D	370 D	460 D	330 D	3100 D	220 D	350 D
Anthracene	880 D	720 D	750 D	600 D	4700 D	380 D	620 D
Benzo(a)anthracene	2200 D	1700 D	1900 D	1500 D	9900 D	1000 D	1500 D
Benzo(a)pyrene	2100 D	1600 D	1900 D	1400 D	9700 D	1100 D	1500 D
Benzo(b)fluoranthene	2700 D	1900 D	2100 D	1700 D	9800 D	1200 D	1800 D
Benzo(g,h,i)perylene	1900 D	1300 D	1600 D	1100 D	6200 D	860 D	1200 D
Benzo(k)fluoranthene	770 D	770 D	960 D	630 D	3300 D	430 D	630 D
Chrysene	2800 D	2100 D	2400 D	1900 D	12000 D	1300 D	2100 D
Dibenz(a,h)anthracene	460 D	320 D	400 D	260 D	1800 D	210 D	290 D
Fluoranthene	4000 D	3200 D	3200 D	2700 D	16000 D	1900 D	2900 D
Fluorene	290 D	220 D	260 D	200 D	1500 D	120 D	210 D
Indeno(1,2,3-c,d)Pyrene	1600 D	1100 D	1200 D	910 D	5000 D	710 D	990 D
Naphthalene	240 TD	230 D	260 D	200 D	790 D	87 TD	220 D
Phenanthrene	1700 D	1500 D	1500 D	1200 D	9200 D	860 D	1300 D
Pyrene	3600 D	2700 D	3000 D	2400 D	13000 D	1700 D	2600 D

µg/kg micrograms per kilogram

Bold Bolded result indicates positively identified compound.

B Analyte detected in an associated blank.

D Sample dilution required for analysis; reported values reflect the dilution.

J Data are estimated due to associated quality control data.

T Analyte was positively identified but the reported concentration is estimated; reported concentration is less than the reporting limit, but greater than the method detection limit.

UJ Potential low bias, possible false negative.

SIM Selective ion monitoring

- Not analyzed

TABLE 3

POLYNUCLEAR AROMATIC HYDROCARBONS SOLID SAMPLE DATA SUMMARY
DEMONSTRATION TESTING AND FULL-SCALE OPERATION OF THE BIOGENESIS SEDIMENT DECONTAMINATION PROCESS
KEASBEY, NEW JERSEY
 (Page 60 of 67)

Field Sample Identification	WS-030506-1640	PSS-040506-1600	PSS-040506-1600B	SS1-040506-1605	SS1-040506-1605B	SS1-040506-1605B	SS2-040506-1610
Sediment Source	Lower Passaic River	Lower Passaic River	Lower Passaic River	Lower Passaic River	Lower Passaic River	Lower Passaic River	Lower Passaic River
Location Identification	WS	PSS	PSS	SS1	SS1	SS1 Dup	SS2
Date Collected	5/3/06	5/4/06	5/4/06	5/4/06	5/4/06	5/4/06	5/4/06
Matrix	Solid	Solid	Solid	Solid	Solid	Solid	Solid
Analyte/Methods (Units)							
Polynuclear Aromatic Hydrocarbons/SW8270C-SIM (µg/kg)							
Acenaphthene	150 TD	250 D	298 DJ	280 D	920 D	677 D	420 D
Acenaphthylene	320 D	490 D	414 DJ	430 D	901 D	681 D	1000 D
Anthracene	450 D	1100 D	973 DJ	9500 D	5440 D	1620 D	1600 D
Benzo(a)anthracene	960 D	2600 D	1780 D	4000 D	11800 D	3350 D	3800 D
Benzo(a)pyrene	900 D	2300 D	1800 D	2200 D	9490 D	2770 D	3600 D
Benzo(b)fluoranthene	1300 D	2800 D	1770 D	2500 D	7810 D	2220 D	3800 D
Benzo(g,h,i)perylene	800 D	1800 D	1310 D	1200 D	5750 D	1780 D	2600 D
Benzo(k)fluoranthene	520 D	1000 D	1720 D	1200 D	9320 D	2630 D	1700 D
Chrysene	1300 D	3100 D	2320 D	5000 D	12800 D	4180 D	4600 D
Dibenz(a,h)anthracene	180 TD	420 D	387 D	310 D	2040 D	544 D	730 D
Fluoranthene	2100 D	4500 D	6300 DJ	8500 D	36700 D	9940 D	5700 D
Fluorene	170 TD	290 D	349 DJ	460 D	763 D	590 D	470 D
Indeno(1,2,3-c,d)Pyrene	670 D	1500 D	1070 D	990 D	5240 D	1480 D	2100 D
Naphthalene	130 TD	300 D	484 DJB	150 TD	661 DB	725 DB	380 D
Phenanthrene	650 D	2800 D	2060 DJ	4900 D	15900 D	3580 D	2700 D
Pyrene	2000 D	3900 D	6470 DJ	6800 D	31700 D	11200 D	5400 D

µg/kg micrograms per kilogram

Bold Bolded result indicates positively identified compound.

B Analyte detected in an associated blank.

D Sample dilution required for analysis; reported values reflect the dilution.

J Data are estimated due to associated quality control data.

T Analyte was positively identified but the reported concentration is estimated; reported concentration is less than the reporting limit, but greater than the method detection limit.

UJ Potential low bias, possible false negative.

SIM Selective ion monitoring

- Not analyzed

TABLE 3

POLYNUCLEAR AROMATIC HYDROCARBONS SOLID SAMPLE DATA SUMMARY
DEMONSTRATION TESTING AND FULL-SCALE OPERATION OF THE BIOGENESIS SEDIMENT DECONTAMINATION PROCESS
KEASBEY, NEW JERSEY
 (Page 61 of 67)

Field Sample Identification	SS2-040506-1610B	RS-040506-1615	RS-040506-1615B	STS-5-040506-1200	STS-6-040506-1500	TS-040506-1635	TS-040506-1635B
Sediment Source	Lower Passaic River	Lower Passaic River	Lower Passaic River	Lower Passaic River	Lower Passaic River	Lower Passaic River	Lower Passaic River
Location Identification	SS2	RS	RS	TS	TS	TS	TS
Date Collected	5/4/06	5/4/06	5/4/06	5/4/06	5/4/06	5/4/06	5/4/06
Matrix	Solid	Solid	Solid	Solid	Solid	Solid	Solid
Analyte/Methods (Units)							
Polynuclear Aromatic Hydrocarbons/SW8270C-SIM (µg/kg)							
Acenaphthene	450 D	270 D	340 D	210 D	220 D	200 D	366 D
Acenaphthylene	1090 D	610 D	501 D	380 D	410 D	400 D	560 D
Anthracene	1710 D	1100 D	1210 D	800 D	900 D	800 D	1350 D
Benzo(a)anthracene	3240 D	2400 D	2000 D	1900 D	2100 D	1900 D	2340 D
Benzo(a)pyrene	3410 D	2500 D	2170 D	1900 D	1900 D	1800 D	2670 D
Benzo(b)fluoranthene	3020 D	2800 D	1960 D	2300 D	2300 D	2100 D	2440 D
Benzo(g,h,i)perylene	2290 D	2000 D	1730 D	1500 D	1600 D	1500 D	2180 D
Benzo(k)fluoranthene	3230 D	1200 D	2060 D	730 D	790 D	880 D	2460 D
Chrysene	4940 D	3100 D	2560 D	2400 D	2800 D	2400 D	3010 D
Dibenz(a,h)anthracene	743 D	470 D	513 D	360 D	390 D	360 D	664 D
Fluoranthene	14500 D	4600 D	6850 D	3400 D	3800 D	3400 D	7580 D
Fluorene	395 D	320 D	412 D	230 D	260 D	240 D	463 D
Indeno(1,2,3-c,d)Pyrene	1960 D	1700 D	1410 D	1200 D	1300 D	1200 D	1790 D
Naphthalene	599 DB	280 D	571 DB	260 D	310 D	270 D	718 DB
Phenanthrene	2580 D	2100 D	2330 D	1700 D	1800 D	1600 D	2660 D
Pyrene	13700 D	4000 D	6960 D	3000 D	3300 D	3000 D	7530 D

µg/kg micrograms per kilogram

Bold Bolded result indicates positively identified compound.

B Analyte detected in an associated blank.

D Sample dilution required for analysis; reported values reflect the dilution.

J Data are estimated due to associated quality control data.

T Analyte was positively identified but the reported concentration is estimated; reported concentration is less than the reporting limit, but greater than the method detection limit.

UJ Potential low bias, possible false negative.

SIM Selective ion monitoring

- Not analyzed

TABLE 3

POLYNUCLEAR AROMATIC HYDROCARBONS SOLID SAMPLE DATA SUMMARY
DEMONSTRATION TESTING AND FULL-SCALE OPERATION OF THE BIOGENESIS SEDIMENT DECONTAMINATION PROCESS
KEASBEY, NEW JERSEY
 (Page 62 of 67)

Field Sample Identification	TS1-040506-1620	TS1-040506-1620B	TS2-040506-1625	TS2-040506-1625B	TS3-040506-1630	TS3-040506-1630B	WS-040506-1640
Sediment Source	Lower Passaic River	Lower Passaic River	Lower Passaic River	Lower Passaic River	Lower Passaic River	Lower Passaic River	Lower Passaic River
Location Identification	TS1	TS1	TS2	TS2	TS3	TS3	WS
Date Collected	5/4/06	5/4/06	5/4/06	5/4/06	5/4/06	5/4/06	5/4/06
Matrix	Solid	Solid	Solid	Solid	Solid	Solid	Solid
Analyte/Methods (Units)							
Polynuclear Aromatic Hydrocarbons/SW8270C-SIM (µg/kg)							
Acenaphthene	1600 DJ	2750 D	150 D	134 D	200 D	355 D	140 D
Acenaphthylene	3700 DJ	4570 D	280 D	197 D	390 D	557 D	290 D
Anthracene	6300 DJ	8420 D	570 D	487 D	810 D	1280 D	480 D
Benzo(a)anthracene	15000 D	16100 D	1700 D	1030 D	1900 D	2300 D	810 D
Benzo(a)pyrene	15000 D	17200 D	1600 D	1190 D	1700 D	2630 D	840 D
Benzo(b)fluoranthene	14000 D	12300 D	1900 D	1010 D	2000 D	2400 D	1200 D
Benzo(g,h,i)perylene	10000 DJ	11500 D	1300 D	939 D	1500 D	2190 D	770 D
Benzo(k)fluoranthene	5800 DJ	13800 D	700 D	1090 D	820 D	2450 D	520 D
Chrysene	16000 D	18300 D	1900 D	1280 D	2300 D	2970 D	1200 D
Dibenz(a,h)anthracene	2600 DJ	3750 D	310 D	288 D	340 D	651 D	170 D
Fluoranthene	21000 D	41600 D	2800 D	3370 D	3300 D	7240 D	1900 D
Fluorene	1900 DJ	2650 D	170 D	160 D	250 D	478 D	140 D
Indeno(1,2,3-c,d)Pyrene	8100 DJ	9540 D	1100 D	798 D	1100 D	1780 D	630 D
Naphthalene	1300 DJ	3370 DB	140 D	233 DB	280 D	722 DB	140 D
Phenanthrene	13000 D	19100 D	1300 D	1170 D	1700 D	2540 D	660 D
Pyrene	20000 D	42900 D	2600 D	3210 D	3100 D	7220 D	1700 D

µg/kg micrograms per kilogram

Bold Bolded result indicates positively identified compound.

B Analyte detected in an associated blank.

D Sample dilution required for analysis; reported values reflect the dilution.

J Data are estimated due to associated quality control data.

T Analyte was positively identified but the reported concentration is estimated; reported concentration is less than the reporting limit, but greater than the method detection limit.

UJ Potential low bias, possible false negative.

SIM Selective ion monitoring

- Not analyzed

TABLE 3

POLYNUCLEAR AROMATIC HYDROCARBONS SOLID SAMPLE DATA SUMMARY
DEMONSTRATION TESTING AND FULL-SCALE OPERATION OF THE BIOGENESIS SEDIMENT DECONTAMINATION PROCESS
KEASBEY, NEW JERSEY
 (Page 63 of 67)

Field Sample Identification	WS-040506-1640B	SPC COMP- 160506-1700	SPP COMP- 170506-1030	TSA-260606-1350	TSA-260606-1350	TSE-260606-1355	TSF-260606-1400
Sediment Source	Lower Passaic River	All	All	Lower Passaic River	Lower Passaic River	Lower Passaic River	Lower Passaic River
Location Identification	WS	TSP	TSP	MSL	MSL	MSL	MSL
Date Collected	5/4/06	5/16/06	5/17/06	6/26/06	6/26/06	6/26/06	6/26/06
Matrix	Solid	Solid	Solid	Solid	Solid	Solid	Solid
Analyte/Methods (Units)							
Polynuclear Aromatic Hydrocarbons/SW8270C-SIM (µg/kg)							
Acenaphthene	351 D	170 D	210 D	58 D	58 D	41 TD	43 TD
Acenaphthylene	490 D	180 D	360 D	73 D	73 D	58 TD	69 TD
Anthracene	992 D	390 D	700 D	150 D	150 D	110 D	130 D
Benzo(a)anthracene	1490 D	780 D	1500 D	230 D	230 D	170 D	220 D
Benzo(a)pyrene	1660 D	630 D	1600 D	210 D	210 D	150 D	200 D
Benzo(b)fluoranthene	1870 D	490 D	1400 D	260 DJ	260 DJ	180 DJ	240 DJ
Benzo(g,h,i)perylene	1520 D	470 D	1300 D	150 D	150 D	200 D	240 D
Benzo(k)fluoranthene	1940 D	490 D	1100 D	110 D	110 D	76 D	80 D
Chrysene	2130 D	790 D	2000 D	280 D	280 D	180 D	240 D
Dibenz(a,h)anthracene	425 D	160 D	490 D	35 TD	35 TDJ	35 TD	53 TD
Fluoranthene	6040 D	1300 D	3200 D	520 D	520 D	310 D	400 D
Fluorene	352 D	210 D	240 D	47 DJ	47 DJ	35 TDJ	38 TDJ
Indeno(1,2,3-c,d)Pyrene	1320 D	390 D	1100 D	120 D	120 DJ	110 D	170 D
Naphthalene	385 DB	280 D	300 D	54 D	54 D	44 TD	56 TD
Phenanthrene	1520 D	820 D	1700 D	250 D	250 D	140 D	180 D
Pyrene	6320 D	1100 D	2200 D	430 DJ	430 DJ	290 DJ	430 DJ

µg/kg micrograms per kilogram

Bold Bolded result indicates positively identified compound.

B Analyte detected in an associated blank.

D Sample dilution required for analysis; reported values reflect the dilution.

J Data are estimated due to associated quality control data.

T Analyte was positively identified but the reported concentration is estimated; reported concentration is less than the reporting limit, but greater than the method detection limit.

UJ Potential low bias, possible false negative.

SIM Selective ion monitoring

- Not analyzed

TABLE 3

POLYNUCLEAR AROMATIC HYDROCARBONS SOLID SAMPLE DATA SUMMARY
DEMONSTRATION TESTING AND FULL-SCALE OPERATION OF THE BIOGENESIS SEDIMENT DECONTAMINATION PROCESS
KEASBEY, NEW JERSEY
 (Page 64 of 67)

Field Sample Identification	MSL01-040107-0905	MSL01-040107-0905	MSL02-040107-0925	MSL03-040107-0940	MSL03-040107-0940	MSL04-040107-0950	MSL05-040107-1000
Sediment Source	Lower Passaic River	Lower Passaic River	Lower Passaic River	Lower Passaic River	Lower Passaic River	Lower Passaic River	Lower Passaic River
Location Identification	MSL	MSL	MSL	MSL	MSL	MSL	MSL
Date Collected	1/4/07	1/4/07	1/4/07	1/4/07	1/4/07	1/4/07	1/4/07
Matrix	Solid	Solid	Solid	Solid	Solid	Solid	Solid
Analyte/Methods (Units)							
Polynuclear Aromatic Hydrocarbons/SW8270C-SIM (µg/kg)							
Acenaphthene	100 D	94 D	68 D	71 D	130 D	79 D	87 D
Acenaphthylene	240 D	230 D	140 D	190 D	260 D	180 D	230 D
Anthracene	420 D	350 D	180 D	360 D	340 D	220 D	270 D
Benzo(a)anthracene	970 D	900 D	430 D	670 D	680 D	480 D	590 D
Benzo(a)pyrene	1100 D	870 D	480 D	740 D	780 D	520 D	640 D
Benzo(b)fluoranthene	1300 D	1000 D	530 D	830 D	930 D	580 D	690 D
Benzo(g,h,i)perylene	930 D	680 D	420 D	660 D	670 D	460 D	630 D
Benzo(k)fluoranthene	480 D	460 D	240 D	400 D	300 D	270 D	330 D
Chrysene	1300 D	1000 D	510 D	830 D	800 D	600 D	710 D
Dibenz(a,h)anthracene	260 D	190 D	110 D	170 D	170 D	120 D	160 D
Fluoranthene	1400 D	1100 D	680 D	940 D	1200 D	820 D	950 D
Fluorene	120 D	130 D	86 D	87 D	150 D	96 D	110 D
Indeno(1,2,3-c,d)Pyrene	780 D	570 D	340 D	530 D	550 D	370 D	480 D
Naphthalene	170 D	100 D	72 D	130 D	120 D	86 D	110 D
Phenanthrene	990 D	630 D	430 D	550 D	800 D	490 D	540 D
Pyrene	1800 D	1300 D	760 D	1200 D	1200 D	860 D	910 D

µg/kg micrograms per kilogram

Bold Bolded result indicates positively identified compound.

B Analyte detected in an associated blank.

D Sample dilution required for analysis; reported values reflect the dilution.

J Data are estimated due to associated quality control data.

T Analyte was positively identified but the reported concentration is estimated; reported concentration is less than the reporting limit, but greater than the method detection limit.

UJ Potential low bias, possible false negative.

SIM Selective ion monitoring

- Not analyzed

TABLE 3

POLYNUCLEAR AROMATIC HYDROCARBONS SOLID SAMPLE DATA SUMMARY
DEMONSTRATION TESTING AND FULL-SCALE OPERATION OF THE BIOGENESIS SEDIMENT DECONTAMINATION PROCESS
KEASBEY, NEW JERSEY
 (Page 65 of 67)

Field Sample Identification	MSL06-040107-1015	MSL07-040107-1025	MSL08-040107-1035	MSL09-040107-1045	MSL10-040107-1055	MSL11-040107-1055	TSP1-112508-1410
Sediment Source	Lower Passaic River	Lower Passaic River	Lower Passaic River	Lower Passaic River	Lower Passaic River	Lower Passaic River	Lower Passaic River
Location Identification	MSL	MSL	MSL	MSL	MSL	MSL	TS
Date Collected	1/4/07	1/4/07	1/4/07	1/4/07	1/4/07	1/4/07	11/25/08
Matrix	Solid	Solid	Solid	Solid	Solid	Solid	SOLID
Analyte/Methods (Units)							
Polynuclear Aromatic Hydrocarbons/SW8270C-SIM (µg/kg)							
Acenaphthene	91 D	94 D	87 D	68 TD	80 TD	73 TD	33 TD
Acenaphthylene	220 D	210 D	190 D	300 D	210 D	200 D	120 D
Anthracene	250 D	270 D	230 D	270 D	220 D	210 D	120 D
Benzo(a)anthracene	630 D	620 D	530 D	640 D	500 D	510 D	430 D
Benzo(a)pyrene	670 D	690 D	600 D	790 D	550 D	570 D	450 D
Benzo(b)fluoranthene	830 D	760 D	730 D	940 D	670 D	610 D	750 D
Benzo(g,h,i)perylene	600 D	620 D	550 D	720 D	510 D	510 D	350 D
Benzo(k)fluoranthene	360 D	350 D	240 D	330 D	280 D	290 D	<87 D
Chrysene	680 D	750 D	640 D	830 D	590 D	580 D	550 D
Dibenz(a,h)anthracene	150 D	150 D	140 D	180 D	130 D	130 D	84 TD
Fluoranthene	990 D	1100 D	870 D	1100 D	860 D	840 D	740 DB
Fluorene	120 D	120 D	110 D	95 D	100 D	95 D	50 TD
Indeno(1,2,3-c,d)Pyrene	490 D	500 D	440 D	570 D	400 D	400 D	260 D
Naphthalene	110 D	97 D	90 D	92 D	81 TD	71 TD	82 TD
Phenanthrene	570 D	670 D	520 D	500 D	470 D	420 D	330 D
Pyrene	1100 D	1100 D	950 D	1100 D	830 D	820 D	570 D

µg/kg micrograms per kilogram

Bold Bolded result indicates positively identified compound.

B Analyte detected in an associated blank.

D Sample dilution required for analysis; reported values reflect the dilution.

J Data are estimated due to associated quality control data.

T Analyte was positively identified but the reported concentration is estimated; reported concentration is less than the reporting limit, but greater than the method detection limit.

UJ Potential low bias, possible false negative.

SIM Selective ion monitoring

- Not analyzed

TABLE 3

POLYNUCLEAR AROMATIC HYDROCARBONS SOLID SAMPLE DATA SUMMARY
DEMONSTRATION TESTING AND FULL-SCALE OPERATION OF THE BIOGENESIS SEDIMENT DECONTAMINATION PROCESS
KEASBEY, NEW JERSEY
 (Page 66 of 67)

Field Sample Identification	TSP2-112508-1415	AD1-112508-1420	AD2-112508-1425	AD3-112508-1550	MS1-112508-1600	MS2-112508-1610	MS3-112508-1620
Sediment Source	Lower Passaic River	None	None	None	Lower Passaic River	Lower Passaic River	Lower Passaic River
Location Identification	TS	AD	AD	AD	MSL	MSL	MSL
Date Collected	11/25/08	11/25/08	11/25/08	11/25/08	11/25/08	11/25/08	11/25/08
Matrix	SOLID	SOLID	SOLID	SOLID	SOLID	SOLID	SOLID
Analyte/Methods (Units)							
Polynuclear Aromatic Hydrocarbons/SW8270C-SIM (µg/kg)							
Acenaphthene	30 TD	<17 D	<360 D	<17 D	13 TD	<110 D	3.6 TD
Acenaphthylene	110 D	<17 D	<360 D	<17 D	42 TD	55 TD	11 TD
Anthracene	120 D	<17 D	<360 D	<17 D	43 TD	38 TD	8.4 TD
Benzo(a)anthracene	460 D	<17 D	<360 D	<17 D	140 D	120 D	36 D
Benzo(a)pyrene	490 D	<17 D	<360 D	<17 D	150 D	140 D	36 D
Benzo(b)fluoranthene	760 D	<17 D	<360 D	<17 D	180 D	240 D	75 D
Benzo(g,h,i)perylene	370 D	<17 D	<360 D	<17 D	<46 D	120 D	34 D
Benzo(k)fluoranthene	<87 D	<17 D	<360 D	<17 D	<46 D	<110 D	<20 D
Chrysene	490 D	<17 D	<360 D	<17 D	180 D	150 D	39 D
Dibenz(a,h)anthracene	96 D	<17 D	<360 D	<17 D	<46 D	29 TD	7.3 TD
Fluoranthene	840 DB	1.7 TDB	<360 D	2.2 TDB	240 TB	220 DB	54 DB
Fluorene	38 TD	<17 D	<360 D	<17 D	<46 D	<110 D	6.9 TD
Indeno(1,2,3-c,d)Pyrene	300 D	<17 D	<360 D	<17 D	<46 D	87 TD	28 D
Naphthalene	85 TD	<17 D	<360 D	<17 D	34 TD	25 TD	16 TD
Phenanthrene	290 D	3.2 TD	<360 D	12 TD	97 D	95 TD	21 D
Pyrene	550 D	<17 D	<360 D	<17 D	160 D	140 D	37 D

µg/kg micrograms per kilogram

Bold Bolded result indicates positively identified compound.

B Analyte detected in an associated blank.

D Sample dilution required for analysis; reported values reflect the dilution.

J Data are estimated due to associated quality control data.

T Analyte was positively identified but the reported concentration is estimated; reported concentration is less than the reporting limit, but greater than the method detection limit.

UJ Potential low bias, possible false negative.

SIM Selective ion monitoring

- Not analyzed

TABLE 3

POLYNUCLEAR AROMATIC HYDROCARBONS SOLID SAMPLE DATA SUMMARY
DEMONSTRATION TESTING AND FULL-SCALE OPERATION OF THE BIOGENESIS SEDIMENT DECONTAMINATION PROCESS
KEASBEY, NEW JERSEY
 (Page 67 of 67)

Field Sample Identification	MS4-112508-1625	MS5-112508-1630
Sediment Source	Lower Passaic River	Lower Passaic River
Location Identification	MSL	MSL
Date Collected	11/25/08	11/25/08
Matrix	SOLID	SOLID
Analyte/Methods (Units)		
Polynuclear Aromatic Hydrocarbons/SW8270C-SIM (µg/kg)		
Acenaphthene	41 D	<42 D
Acenaphthylene	64 D	19 TD
Anthracene	130 D	17 TD
Benzo(a)anthracene	320 D	55 D
Benzo(a)pyrene	290 D	60 D
Benzo(b)fluoranthene	480 D	96 D
Benzo(g,h,i)perylene	300 D	54 D
Benzo(k)fluoranthene	<22 D	<42 D
Chrysene	380 D	64 D
Dibenz(a,h)anthracene	71 D	<42 D
Fluoranthene	670 D	89 D
Fluorene	62 D	<42 D
Indeno(1,2,3-c,d)Pyrene	240 D	45 D
Naphthalene	58 D	<42 D
Phenanthrene	460 D	41 TDB
Pyrene	420 D	63 D

µg/kg micrograms per kilogram

Bold Bolded result indicates positively identified compound.

B Analyte detected in an associated blank.

D Sample dilution required for analysis; reported values reflect the dilution.

J Data are estimated due to associated quality control data.

T Analyte was positively identified but the reported concentration is estimated; reported concentration is less than the reporting limit, but greater than the method detection limit.

UJ Potential low bias, possible false negative.

SIM Selective ion monitoring

- Not analyzed

TABLE 4

PESTICIDES SOLID SAMPLE DATA SUMMARY
DEMONSTRATION TESTING AND FULL-SCALE OPERATION OF THE BIOGENESIS SEDIMENT DECONTAMINATION PROCESS
KEASBEY, NEW JERSEY
 (Page 1 of 23)

Field Sample Identification	BAY-1	RS-211205-1000	TS-211205-1715	WS1-211205-1800	TS-291205-1100	WS-291205-1110	RS-030106-1600
Sediment Source	Raritan River	Raritan River	Raritan River	Raritan River	Raritan River	Raritan River	Raritan River
Location Identification	PPS	RS	TS	WS	TS	WS	RS
Date Collected	11/23/05	12/21/05	12/21/05	12/21/05	12/29/05	12/29/05	1/3/06
Matrix	Solid	Solid	Solid	Solid	Solid	Solid	Solid
Analyte/Methods (Units)							
Pesticides/SW80801A (µg/kg)							
Aldrin	<3.4	<4.7	1.2 TJ	<5.5	0.55 TJ	1.6 TJ	7.0
alpha BHC	<3.4	<4.7	1.4 T	3.1 T	0.32 TJ	0.99 TJ	<4.7
alpha Endosulfan	<3.4	<4.7	<2.3	<5.5	<2.5	<5.4	<4.7
alpha-Chlordane	<3.4	1.6 TJ	<2.3	6.6 J	2.4 T	6.3	3.4 T
beta BHC	<3.4	<4.7	<2.3	<5.5	<2.5	<5.4	<4.7
beta Endosulfan	<3.4	1.6 TJ	<2.3	7.1 J	2.6	5.4 J	<4.7
Chlordane	-	<4.7	<2.3	<5.5	<2.5	<5.4	<4.7
delta BHC	<3.4	<4.7	<2.3	<5.5	<2.5	<5.4	<4.7
Dieldrin	0.64 T	<4.7	<2.3	<5.5	1.5 TJ	9.2	2.0 TJ
Endosulfan sulfate	0.64 T	0.87 T	<2.3	3.4 TJ	0.92 T	<5.4	2.3 TJ
Endrin	<3.4	<4.7	<2.3	<5.5	2.7	<5.4	<4.7
Endrin aldehyde	2.6 T	<4.7	<2.3	<5.5	<2.5	<5.4	<4.7
Endrin ketone	<3.4	<4.7	0.61 TJ	<5.5	<2.5	<5.4	<4.7
gamma BHC (Lindane)	<3.4	<4.7	<2.3	<5.5	<2.5	<5.4	<4.7
gamma-Chlordane	<3.4	<4.7	0.63 TJ	2 TJ	0.73 TJ	2.5 TJ	0.77 TJ
Heptachlor	<3.4	<4.7	<2.3	<5.5	<2.5	<5.4	<4.7
Heptachlor epoxide	<3.4	<4.7	1.6 T	1.1 TJ	0.45 TJ	1.8 TJ	<4.7
Methoxychlor	<6.5	<9.1	<4.5	<11	<4.8	9.0 T	<9.0
p,p'-DDD	<3.4	1.1 TJ	4.6	9.7 J	3.9	10	2.0 TJ
p,p'-DDE	0.49 T	5.3	<2.3	18	2.8 J	8.8 J	6.7
p,p'-DDT	<3.4	<4.7	<2.3	<5.5	<2.5	<5.4	2.7 TJ
Toxaphene	<130	<180	<92	<7.3	<97	<7.2	<180

µg/kg micrograms per kilogram.

Italic Italicized result indicates analyte reported to the method detection limit.

Bold Bolded result indicates positively identified compound.

- Not analyzed.

D Sample dilution required for analysis; reported values reflect the dilution.

J Data are estimated due to associated quality control data.

T Analyte was positively identified but the reported concentration is estimated; reported concentration is less than the reporting limit, but greater than the method detection limit.

11/18/09

Table 4 Pesticides - Solids.xls

TABLE 4

PESTICIDES SOLID SAMPLE DATA SUMMARY
DEMONSTRATION TESTING AND FULL-SCALE OPERATION OF THE BIOGENESIS SEDIMENT DECONTAMINATION PROCESS
KEASBEY, NEW JERSEY
 (Page 2 of 23)

Field Sample Identification	TS-030106-1645	WS1-030106-1615	WS2-030106-1630	RS-040106-1300	TS-040106-1100	WS-040106-1400	RS-050106-1500
Sediment Source	Raritan River	Raritan River	Raritan River	Raritan River	Raritan River	Raritan River	Raritan River
Location Identification	TS	WS1	WS2	RS	TS	WS	RS
Date Collected	1/3/06	1/3/06	1/3/06	1/4/06	1/4/06	1/4/06	1/5/06
Matrix	Solid	Solid	Solid	Solid	Solid	Solid	Solid
Analyte/Methods (Units)							
Pesticides/SW80801A (µg/kg)							
Aldrin	<2.4	<32 D	<24 D	<39 D	<12 D	<27 D	5.7 J
alpha BHC	<2.4	<32 D	4.9 TD	<39 D	<12 D	<27 D	0.51 TJ
alpha Endosulfan	<2.4	<32 D	<24 D	<39 D	<12 D	<27 D	<5.2
alpha-Chlordane	<2.4	<32 D	<24 D	<39 D	<12 D	<27 D	3.1 TJ
beta BHC	<2.4	<32 D	<24 D	<39 D	<12 D	<27 D	<5.2
beta Endosulfan	1.0 TJ	<32 D	<24 D	<39 D	<12 D	<27 D	<5.2
Chlordane	<2.4	<320 D	<240 D	<390 D	<120 D	<270 D	<5.2
delta BHC	<2.4	<32 D	<24 D	<39 D	<12 D	<27 D	<5.2
Dieldrin	2.7 J	<32 D	<24 D	<39 D	<12 D	<27 D	6.9
Endosulfan sulfate	<2.4	<32 D	<24 D	<39 D	<12 D	<27 D	0.83 TJ
Endrin	<2.4	<32 D	<24 D	<39 D	<12 D	<27 D	<5.2
Endrin aldehyde	<2.4	<32 D	<24 D	<39 D	<12 D	<27 D	<5.2
Endrin ketone	<2.4	<32 D	<24 D	<39 D	<12 D	<27 D	<5.2
gamma BHC (Lindane)	<2.4	<32 D	<24 D	<39 D	<12 D	<27 D	<5.2
gamma-Chlordane	0.63 TJ	<32 D	<24 D	<39 D	<12 D	<27 D	0.85 TJ
Heptachlor	<2.4	<32 D	<24 D	<39 D	<12 D	<27 D	<5.2
Heptachlor epoxide	0.79 TJ	<32 D	<24 D	<39 D	<12 D	<27 D	0.64 TJ
Methoxychlor	2.6 TJ	<61 D	<48 D	<75 D	<24 D	<53 D	<10
p,p'-DDD	4.0 J	3.4 TDJ	<24 D	4.3 TDJ	6.9 TD	<27 D	9.8
p,p'-DDE	5.8	11 TD	7.9 TDJ	6.4 TDJ	<12 D	<27 D	9.6
p,p'-DDT	5.6 J	<32 D	2.6 TDJ	<39 D	2.7 TDJ	<27 D	8.3 J
Toxaphene	<93	<42 D	<33 D	<51 D	<17 D	<36 D	<7

µg/kg micrograms per kilogram.

Italic Italicized result indicates analyte reported to the method detection limit.

Bold Bolded result indicates positively identified compound.

- Not analyzed.

D Sample dilution required for analysis; reported values reflect the dilution.

J Data are estimated due to associated quality control data.

T Analyte was positively identified but the reported concentration is estimated; reported concentration is less than the reporting limit, but greater than the method detection limit.

11/18/09

Table 4 Pesticides - Solids.xls

TABLE 4
PESTICIDES SOLID SAMPLE DATA SUMMARY
DEMONSTRATION TESTING AND FULL-SCALE OPERATION OF THE BIOGENESIS SEDIMENT DECONTAMINATION PROCESS
KEASBEY, NEW JERSEY
 (Page 3 of 23)

Field Sample Identification	TS-050106-1505	WS-050106-1510	RS-060106-1531	TS-060106-1532	WS-060106-1533	RS-090106-1500	TS-090106-1501
Sediment Source	Raritan River	Raritan River	Raritan River	Raritan River	Raritan River	Raritan River	Raritan River
Location Identification	TS	WS	RS	TS	WS	RS	TS
Date Collected	1/5/06	1/5/06	1/6/06	1/6/06	1/6/06	1/9/06	1/9/06
Matrix	Solid	Solid	Solid	Solid	Solid	Solid	Solid
Analyte/Methods (Units)							
Pesticides/SW80801A (µg/kg)							
Aldrin	<2.6	1.6 TJ	<21	<2.7	<4.8	<6.7	<2.6
alpha BHC	0.27 TJ	0.57 TJ	<21	4.4 J	0.48 TJ	<6.7	<2.6
alpha Endosulfan	<2.6	<4.7	<21	3.3 J	1.8 TJ	<6.7	<2.6
alpha-Chlordane	<2.6	3.4 TJ	<21	<2.7	4.2 T	3.4 T	1.7 T
beta BHC	<2.6	<4.7	<21	<2.7	<4.8	<6.7	<2.6
beta Endosulfan	1.8 T	<4.7	4.2 TJ	<2.7	6.6 J	3.2 TJ	1.7 T
Chlordane	<26	<47	<210	<27	<48	<67	<26
delta BHC	<2.6	<4.7	<21	<2.7	<4.8	<6.7	<2.6
Dieldrin	1.4 TJ	3.2 T	<21	4.1 J	3.5 TJ	2.2 TJ	0.7 TJ
Endosulfan sulfate	<2.6	<4.7	<21	1.3 TJ	<4.8	2.1 T	<2.6
Endrin	<2.6	<4.7	8.0 TJ	5.4	8.0	<6.7	<2.6
Endrin aldehyde	<2.6	<4.7	<21	<2.7	<4.8	<6.7	<2.6
Endrin ketone	<2.6	<4.7	<21	<2.7	<4.8	<6.7	<2.6
gamma BHC (Lindane)	<2.6	<4.7	<21	<2.7	<4.8	<6.7	<2.6
gamma-Chlordane	0.64 TJ	<4.7	<21	4.6 J	2.0 TJ	<6.7	0.39 TJ
Heptachlor	<2.6	<4.7	<21	<2.7	<4.8	<6.7	<2.6
Heptachlor epoxide	0.94 TJ	0.95 TJ	<21	<2.7	0.84 TJ	<6.7	<2.6
Methoxychlor	<5.0	<9.2	<40	<5.2	<9.3	<13	<5.0
p,p'-DDD	3.2	2.4 TJ	3.9 TJ	6.3	6.3 J	3.1 TJ	3.3
p,p'-DDE	3.5 J	7.5	3.3 TJ	11	4.6 TJ	4.6 TJ	4.1
p,p'-DDT	5.2	2.8 TJ	9.7 T	23	8.4 J	9.4	8.4 J
Toxaphene	<100	<190	<28	<110	<190	<8.9	<100

µg/kg micrograms per kilogram.

Italic Italicized result indicates analyte reported to the method detection limit.

Bold Bolded result indicates positively identified compound.

- Not analyzed.

D Sample dilution required for analysis; reported values reflect the dilution.

J Data are estimated due to associated quality control data.

T Analyte was positively identified but the reported concentration is estimated; reported concentration is less than the reporting limit, but greater than the method detection limit.

11/18/09

Table 4 Pesticides - Solids.xls

TABLE 4

PESTICIDES SOLID SAMPLE DATA SUMMARY
DEMONSTRATION TESTING AND FULL-SCALE OPERATION OF THE BIOGENESIS SEDIMENT DECONTAMINATION PROCESS
KEASBEY, NEW JERSEY
 (Page 4 of 23)

Field Sample Identification	WS-090106-1502	RS-100106-1600	TS-100106-1601	WS-100106-1602	RS-110106-1630	TS-110106-1631	RS-120106-1630
Sediment Source	Raritan River	Raritan River	Raritan River	Raritan River	Raritan River	Raritan River	Raritan River
Location Identification	WS	RS	TS	WS	RS	TS	RS
Date Collected	1/9/06	1/10/06	1/10/06	1/10/06	1/11/06	1/11/06	1/12/06
Matrix	Solid	Solid	Solid	Solid	Solid	Solid	Solid
Analyte/Methods (Units)							
Pesticides/SW80801A (µg/kg)							
Aldrin	<4.6	<17 D	<32 D	1.2 TD	0.78 TJ	<3.5	<6.1
alpha BHC	<4.6	<17 D	11 TDJ	<8.4 D	0.86 TJ	4.1 J	<6.1
alpha Endosulfan	<4.6	<17 D	3.8 TD	<8.4 D	<4.8	0.54 TJ	<6.1
alpha-Chlordane	1.7 TJ	3.3 TDJ	<32 D	<8.4 D	1.7 TJ	<3.5	<6.1
beta BHC	<4.6	<17 D	<32 D	<8.4 D	<4.8	<3.5	<6.1
beta Endosulfan	3.5 TJ	<17 D	<32 DJ	<8.4 D	2.2 T	<3.5	<6.1
Chlordane	<46	<170 D	<320 D	<84 D	15 TJ	<35	<61
delta BHC	<4.6	<17 D	<32 D	<8.4 D	0.69 T	<3.5	<6.1
Dieldrin	1.3 TJ	<17 D	<32 D	<8.4 D	0.96 T	11	<6.1
Endosulfan sulfate	<4.6	16 TDJ	<32 D	<8.4 D	4.2 T	3.0 TJ	<6.1
Endrin	<4.6	<17 D	8.8 TDJ	<8.4 D	<4.8	<3.5	<6.1
Endrin aldehyde	<4.6	120 DJ	180 D	<8.4 D	<4.8	<3.5	<6.1
Endrin ketone	<4.6	<17 D	<32 D	<8.4 D	<4.8	3.4 T	<6.1
gamma BHC (Lindane)	<4.6	<17 D	<32 D	<8.4 D	<4.8	<3.5	<6.1
gamma-Chlordane	0.68 TJ	<17 D	<32 D	<8.4 D	<4.8	0.74 TJ	<6.1
Heptachlor	<4.6	<17 D	<32 D	<8.4 D	1.5 T	<3.5	<6.1
Heptachlor epoxide	<4.6	<17 D	9.7 TDJ	<8.4 D	<4.8	3.7 J	<6.1
Methoxychlor	<8.9	<33 D	<61 D	<16 D	<9.3	<6.9	<12
p,p'-DDD	3.5 TJ	<17 D	24 TDJ	<8.4 D	2.3 TJ	6.4 J	0.67 TJ
p,p'-DDE	3.7 TJ	7.3 TDJ	<32 D	<8.4 D	2.9 TJ	9.8 J	<6.1
p,p'-DDT	7.1	<17 D	<32 D	<8.4 D	<4.8	<3.5	<6.1
Toxaphene	<180	<23 D	<42 D	<11 D	<190	<140	<8.1

µg/kg micrograms per kilogram.

Italic Italicized result indicates analyte reported to the method detection limit.

Bold Bolded result indicates positively identified compound.

- Not analyzed.

D Sample dilution required for analysis; reported values reflect the dilution.

J Data are estimated due to associated quality control data.

T Analyte was positively identified but the reported concentration is estimated; reported concentration is less than the reporting limit, but greater than the method detection limit.

11/18/09

Table 4 Pesticides - Solids.xls

TABLE 4

PESTICIDES SOLID SAMPLE DATA SUMMARY
DEMONSTRATION TESTING AND FULL-SCALE OPERATION OF THE BIOGENESIS SEDIMENT DECONTAMINATION PROCESS
KEASBEY, NEW JERSEY
 (Page 5 of 23)

Field Sample Identification	TS-120106-1601	WS-120106-1602	RS-190106-1600	TS-190106-1601	WS-190106-1602	RS-240106-1530	TS-240106-1630
Sediment Source	Raritan River	Raritan River	Lower Passaic River	Lower Passaic River	Lower Passaic River	Lower Passaic River	Lower Passaic River
Location Identification	TS	WS	RS	TS	WS	RS	TS
Date Collected	1/12/06	1/12/06	1/19/06	1/19/06	1/19/06	1/24/06	1/24/06
Matrix	Solid	Solid	Solid	Solid	Solid	Solid	Solid
Analyte/Methods (Units)							
Pesticides/SW80801A (µg/kg)							
Aldrin	<2.9	0.67 T	<91 D	14 TDJ	<65 D	9.1 TDJ	6.7 TDJ
alpha BHC	0.51 T	0.52 T	<91 D	<32 D	<65 D	<40 D	<14 D
alpha Endosulfan	<2.9	<5.3	<91 D	<32 D	<65 D	<40 D	<14 D
alpha-Chlordane	<2.9	2.1 TJ	50 TD	68 D	40 TDJ	49 D	34 D
beta BHC	<2.9	<5.3	<91 D	<32 D	<65 D	<40 D	<14 D
beta Endosulfan	6.5	<5.3	<91 D	44 D	<65 D	19 TDJ	13 TDJ
Chlordane	20 T	<5.3	<910 D	<320 D	<650 D	<400 D	<140 D
delta BHC	<2.9	<5.3	<91 D	<32 D	<65 D	<40 D	<14 D
Dieldrin	3.2 J	2.6 T	<91 D	23 TDJ	42 TD	16 TD	7.1 TDJ
Endosulfan sulfate	10	0.88 TJ	<91 D	<32 D	<65 D	<40 D	2.1 TDJ
Endrin	<2.9	<5.3	27 TDJ	25 TDJ	28 TDJ	15 TD	4.5 TDJ
Endrin aldehyde	5.3 J	<5.3	<91 D	<32 D	<65 D	13 TDJ	15 DJ
Endrin ketone	1.7 TJ	<5.3	<91 D	<32 D	<65 D	<40 D	13 TDJ
gamma BHC (Lindane)	<2.9	0.48 TJ	<91 D	<32 D	<65 D	<40 D	<14 D
gamma-Chlordane	1.7 TJ	<5.3	27 TDJ	52 D	24 TDJ	36 TD	27 D
Heptachlor	0.37 T	<5.3	<91 D	<32 D	<65 D	<40 D	<14 D
Heptachlor epoxide	2.5 TJ	<5.3	<91 D	<32 D	<65 D	<40 D	6.7 TDJ
Methoxychlor	44.0 TJ	<10	<180 D	<62 D	<130 D	<78 D	<26 D
p,p'-DDD	10	1.2 T	<91 D	<32 D	<65 D	44 DJ	38 DJ
p,p'-DDE	8.9	2.2 TJ	110 D	120 D	110 D	83 D	67 D
p,p'-DDT	7.5 J	<5.3	71 TDJ	89 D	67 DJ	36 TDJ	82 D
Toxaphene	<110	<7.1	<120 D	<42 D	<86 D	<53 D	<18 D

µg/kg micrograms per kilogram.

Italic Italicized result indicates analyte reported to the method detection limit.

Bold Bolded result indicates positively identified compound.

- Not analyzed.

D Sample dilution required for analysis; reported values reflect the dilution.

J Data are estimated due to associated quality control data.

T Analyte was positively identified but the reported concentration is estimated; reported concentration is less than the reporting limit, but greater than the method detection limit.

11/18/09

Table 4 Pesticides - Solids.xls

TABLE 4

PESTICIDES SOLID SAMPLE DATA SUMMARY
DEMONSTRATION TESTING AND FULL-SCALE OPERATION OF THE BIOGENESIS SEDIMENT DECONTAMINATION PROCESS
KEASBEY, NEW JERSEY
 (Page 6 of 23)

Field Sample Identification	RS-270106-1400	TS-270106-1401	TS-270106-1530	WS-270106-1402	WS-270106-1531	RS-300106-1700	WS2-300106-1702
Sediment Source	Lower Passaic River	Lower Passaic River	Lower Passaic River	Lower Passaic River	Lower Passaic River	Raritan River	Raritan River
Location Identification	RS	TS	TS	WS	WS	RS	WS2
Date Collected	1/27/06	1/27/06	1/27/06	1/27/06	1/27/06	1/30/06	1/30/06
Matrix	Solid	Solid	Solid	Solid	Solid	Solid	Solid
Analyte/Methods (Units)							
Pesticides/SW80801A (µg/kg)							
Aldrin	2.5 TDJ	1.6 TDJ	4.1 TDJ	4.3 TDJ	2.1 TDJ	<46 D	7.6 TDJ
alpha BHC	<13 D	<6.5 D	<7.0 D	<15 D	<16 D	<46 D	<16 D
alpha Endosulfan	<13 D	<6.5 D	1.0 TDJ	<15 D	<16 D	<46 D	<16 D
alpha-Chlordane	13 D	23 D	25 D	25 D	9.6 TD	<46 D	19 DJ
beta BHC	<13 D	<6.5 D	<7.0 D	<15 D	<16 D	<46 D	<16 D
beta Endosulfan	6.3 TDJ	9.0 DJ	11 DJ	11 TDJ	4.0 TDJ	<46 D	<16 D
Chlordane	<130 D	<65 D	<70 D	<150 D	<160 D	<460 D	<160 D
delta BHC	<13 D	<6.5 D	<7.0 D	<15 D	<16 D	<46 D	2.6 TD
Dieldrin	5.5 TD	8.8 D	7.2 D	11 TD	1.8 TDJ	<46 D	5.1 TDJ
Endosulfan sulfate	<13 D	1.4 TDJ	<7.0 D	<15 D	<16 D	<46 D	<16 D
Endrin	6.4 TD	5.7 TDJ	4.0 TDJ	11 TD	<16 D	21 TD	6.6 TDJ
Endrin aldehyde	3.2 TDJ	9.0 DJ	3.1 TDJ	10 TDJ	<16 D	<46 D	<16 D
Endrin ketone	<13 D	<6.5 D	<7.0 D	12 TDJ	<16 D	<46 D	<16 D
gamma BHC (Lindane)	<13 D	<6.5 D	<7.0 D	<15 D	<16 D	<46 D	<16 D
gamma-Chlordane	9.9 TD	18 D	19 D	19 D	6.7 TD	6.3 TDJ	18 DJ
Heptachlor	<13 D	<6.5 D	<7.0 D	<15 D	<16 D	<46 D	<16 D
Heptachlor epoxide	2.6 TDJ	4.7 TDJ	2.7 TDJ	4.7 TDJ	2.3 TDJ	<46 D	2.4 TDJ
Methoxychlor	<26 D	<13 D	<14 D	<30 D	<32 D	<89 D	<32 D
p,p'-DDD	9.8 TDJ	38 D	26 DJ	22 DJ	6.2 TDJ	20 TDJ	<16 D
p,p'-DDE	19 D	39 D	42 D	42 D	10 TDJ	21 TD	50 D
p,p'-DDT	12 TDJ	27 D	30 D	24 DJ	8.0 TDJ	<46 D	29 D
Toxaphene	<18 D	<8.6 D	<9.3 D	<20 D	<22 D	<61 D	<22 D

µg/kg micrograms per kilogram.

Italic Italicized result indicates analyte reported to the method detection limit.

Bold Bolded result indicates positively identified compound.

- Not analyzed.

D Sample dilution required for analysis; reported values reflect the dilution.

J Data are estimated due to associated quality control data.

T Analyte was positively identified but the reported concentration is estimated; reported concentration is less than the reporting limit, but greater than the method detection limit.

11/18/09

Table 4 Pesticides - Solids.xls

TABLE 4

PESTICIDES SOLID SAMPLE DATA SUMMARY
DEMONSTRATION TESTING AND FULL-SCALE OPERATION OF THE BIOGENESIS SEDIMENT DECONTAMINATION PROCESS
KEASBEY, NEW JERSEY
 (Page 7 of 23)

Field Sample Identification	RS-310106-1700	TS-310106-1701	WS-310106-1702	RS-010206-1600	TS-010206-1601	WS-010206-1602	RS-020206-1800
Sediment Source	Raritan River	Raritan River	Raritan River	Raritan River	Raritan River	Raritan River	Raritan River
Location Identification	RS	TS	WS	RS	TS	WS	RS
Date Collected	1/31/06	1/31/06	1/31/06	2/1/06	2/1/06	2/1/06	2/2/06
Matrix	Solid	Solid	Solid	Solid	Solid	Solid	Solid
Analyte/Methods (Units)							
Pesticides/SW80801A (µg/kg)							
Aldrin	<99 D	5.8 TDJ	<28 D	<40 D	<13 D	<24 D	<54 D
alpha BHC	<99 D	<14 D	<28 D	<40 D	<13 D	<24 D	<54 D
alpha Endosulfan	<99 D	<14 D	<28 D	<40 D	<13 D	<24 D	<54 D
alpha-Chlordane	<99 D	<14 D	<28 D	<40 D	<13 D	<24 D	<54 D
beta BHC	<99 D	<14 D	<28 D	<40 D	<13 D	<24 D	<54 D
beta Endosulfan	<99 D	<14 D	<28 D	<40 D	<13 D	<24 D	<54 D
Chlordane	<990 D	<140 D	<280 D	<400 D	<130 D	<240 D	<540 D
delta BHC	<99 D	<14 D	<28 D	<40 D	<13 D	<24 D	<54 D
Dieldrin	<99 D	<14 D	<28 D	<40 D	3.7 TDJ	3.3 TDJ	<54 D
Endosulfan sulfate	<99 D	<14 D	<28 D	<40 D	<13 D	<24 D	<54 D
Endrin	<99 D	2.4 TDJ	<28 D	<40 D	<13 D	<24 D	<54 D
Endrin aldehyde	<99 D	<14 D	<28 D	<40 D	<13 D	<24 D	<54 D
Endrin ketone	<99 D	<14 D	<28 D	<40 D	<13 D	<24 D	<54 D
gamma BHC (Lindane)	<99 D	<14 D	<28 D	<40 D	<13 D	<24 D	<54 D
gamma-Chlordane	<99 D	2.5 TDJ	<28 D	<40 D	<13 D	<24 D	<54 D
Heptachlor	<99 D	<14 D	<28 D	<40 D	<13 D	<24 D	<54 D
Heptachlor epoxide	<99 D	<14 D	<28 D	<40 D	<13 D	<24 D	<54 D
Methoxychlor	<190 D	<27 D	<55 D	<78 D	<25 D	<47 D	<110 D
p,p'-DDD	<99 D	<14 D	<28 D	<40 D	20 D	11 TD	<54 D
p,p'-DDE	<99 D	19 D	6.4 TD	12 TD	15 D	13 TD	9.9 TD
p,p'-DDT	<99 D	770 D	<28 D	<40 D	32 D	<24 D	<54 D
Toxaphene	<130 D	<19 D	<38 D	<54 D	<17 D	<32 D	<72 D

µg/kg micrograms per kilogram.

Italic Italicized result indicates analyte reported to the method detection limit.

Bold Bolded result indicates positively identified compound.

- Not analyzed.

D Sample dilution required for analysis; reported values reflect the dilution.

J Data are estimated due to associated quality control data.

T Analyte was positively identified but the reported concentration is estimated; reported concentration is less than the reporting limit, but greater than the method detection limit.

11/18/09

Table 4 Pesticides - Solids.xls

TABLE 4

PESTICIDES SOLID SAMPLE DATA SUMMARY
DEMONSTRATION TESTING AND FULL-SCALE OPERATION OF THE BIOGENESIS SEDIMENT DECONTAMINATION PROCESS
KEASBEY, NEW JERSEY
 (Page 8 of 23)

Field Sample Identification	TS-020206-1801	WS-020206-1802	RS-030206-1200	TS-030206-1201	WS-030206-1202	RS-060206-1930	TS-060206-1931
Sediment Source	Raritan River	Raritan River	Raritan River	Raritan River	Raritan River	Raritan River	Raritan River
Location Identification	TS	WS	RS	TS	WS	RS	TS
Date Collected	2/2/06	2/2/06	2/3/06	2/3/06	2/3/06	2/6/06	2/6/06
Matrix	Solid	Solid	Solid	Solid	Solid	Solid	Solid
Analyte/Methods (Units)							
Pesticides/SW80801A (µg/kg)							
Aldrin	<14 D	<27 D	<24 D	1.8 TDJ	<31 D	<13 D	<6.5 D
alpha BHC	<14 D	<27 D	<24 D	1.8 TDJ	<31 D	<13 D	0.71 TD
alpha Endosulfan	<14 D	<27 D	<24 D	<14 D	<31 D	<13 D	<6.5 D
alpha-Chlordane	<14 D	<27 D	<24 D	<14 D	<31 D	<13 D	1.1 TDJ
beta BHC	<14 D	<27 D	<24 D	<14 D	<31 D	<13 D	<6.5 D
beta Endosulfan	<14 D	<27 D	<24 D	4.3 TDJ	<31 D	<13 D	2.5 TDJ
Chlordane	<140 D	<270 D	<240 D	<140 D	<310 D	<130 D	<65 D
delta BHC	<14 D	<27 D	<24 D	<14 D	<31 D	<13 D	<6.5 D
Dieldrin	<14 D	<27 D	<24 D	2.5 TDJ	<31 D	2.2 TDJ	2.5 TDJ
Endosulfan sulfate	<14 D	<27 D	<24 D	<14 D	<31 D	<13 D	2.1 TDJ
Endrin	2.6 TD	<27 D	2.9 TD	<14 D	<31 D	2.2 TDJ	<6.5 D
Endrin aldehyde	<14 D	<27 D	<24 D	<14 D	<31 D	<13 D	<6.5 D
Endrin ketone	<14 D	<27 D	<24 D	<14 D	<31 D	<13 D	<6.5 D
gamma BHC (Lindane)	<14 D	<27 D	<24 D	<14 D	<31 D	<13 D	<6.5 D
gamma-Chlordane	<14 D	<27 D	<24 D	<14 D	<31 D	<13 D	<6.5 D
Heptachlor	<14 D	<27 D	<24 D	<14 D	<31 D	<13 D	<6.5 D
Heptachlor epoxide	<14 D	<27 D	<24 D	<14 D	<31 D	<13 D	<6.5 D
Methoxychlor	<27 D	<52 D	<46 D	<27 D	<59 D	<26 D	<13 D
p,p'-DDD	13 TD	6.1 TD	7.2 TDJ	18 D	<31 D	5.4 TD	13 D
p,p'-DDE	12 TD	10 TD	6.7 TDJ	10 TD	4.1 TD	8.2 TD	11 D
p,p'-DDT	6.2 TDJ	<27 D	22 TDJ	50 D	3.6 TDJ	<13 D	160 D
Toxaphene	<18 D	<35 D	<31 D	<18 D	<41 D	<17 D	<8.7 D

µg/kg micrograms per kilogram.

Italic Italicized result indicates analyte reported to the method detection limit.

Bold Bolded result indicates positively identified compound.

- Not analyzed.

D Sample dilution required for analysis; reported values reflect the dilution.

J Data are estimated due to associated quality control data.

T Analyte was positively identified but the reported concentration is estimated; reported concentration is less than the reporting limit, but greater than the method detection limit.

11/18/09

Table 4 Pesticides - Solids.xls

TABLE 4

PESTICIDES SOLID SAMPLE DATA SUMMARY
DEMONSTRATION TESTING AND FULL-SCALE OPERATION OF THE BIOGENESIS SEDIMENT DECONTAMINATION PROCESS
KEASBEY, NEW JERSEY
 (Page 9 of 23)

Field Sample Identification	WS-060206-1932	SP-070206-1445	RS-070206-1630	TS-070206-1631	TS-070206-1631 DRIED	WS-070206-1632	RS-080206-1700
Sediment Source	Raritan River	Raritan River	Raritan River	Raritan River	Raritan River	Raritan River	Raritan River
Location Identification	WS	PPS	RS	TS	TS	WS	RS
Date Collected	2/6/06	2/7/06	2/7/06	2/7/06	2/7/06	2/7/06	2/8/06
Matrix	Solid	Solid	Solid	Solid	Solid	Solid	Solid
Analyte/Methods (Units)							
Pesticides/SW80801A (µg/kg)							
Aldrin	<15 D	6.6 TDJ	<27 D	3.6 TDJ	<11 D	<15 D	1.7 TDJ
alpha BHC	<15 D	<20 D	<27 D	1.5 TDJ	<11 D	<15 D	<13 D
alpha Endosulfan	<15 D	<20 D	<27 D	<6.7 D	<11 D	<15 D	<13 D
alpha-Chlordane	<15 D	11 TDJ	<27 D	4.9 TDJ	<11 D	<15 D	<13 D
beta BHC	<15 D	<20 D	<27 D	<6.7 D	<11 D	<15 D	<13 D
beta Endosulfan	<15 D	15 TD	<27 D	2.9 TD	5.6 TD	<15 D	<13 D
Chlordane	<150 D	<200 D	<270 D	<67 D	<110 D	<150 D	<130 D
delta BHC	<15 D	<20 D	<27 D	<6.7 D	<11 D	<15 D	<13 D
Dieldrin	4.1 TD	18 TDJ	<27 D	2.2 TDJ	3.3 TD	2.0 TDJ	<13 D
Endosulfan sulfate	<15 D	<20 D	<27 D	2.7 TDJ	<11 D	<15 D	<13 D
Endrin	<15 D	4.9 TDJ	<27 D	<6.7 D	4.7 TD	<15 D	<13 D
Endrin aldehyde	<15 D	<20 D	<27 D	<6.7 D	<11 D	<15 D	<13 D
Endrin ketone	<15 D	<20 D	<27 D	<6.7 D	<11 D	<15 D	<13 D
gamma BHC (Lindane)	<15 D	<20 D	<27 D	<6.7 D	<11 D	<15 D	<13 D
gamma-Chlordane	<15 D	19 TD	<27 D	1.6 TDJ	<11 D	<15 D	<13 D
Heptachlor	<15 D	<20 D	<27 D	<6.7 D	<11 D	<15 D	<13 D
Heptachlor epoxide	<15 D	<20 D	<27 D	<6.7 D	<11 D	<15 D	<13 D
Methoxychlor	<28 D	<39 D	<52 D	<13 D	<21 D	<28 D	<24 D
p,p'-DDD	4.2 TDJ	120 D	6.1 TD	15 D	11 D	4.7 TD	6.8 TDJ
p,p'-DDE	8.4 TD	550 D	11 TD	17 D	1.9 TD	8.7 TD	11 TD
p,p'-DDT	<15 D	81 DJ	<27 D	12 DJ	<11 D	<15 D	<13 D
Toxaphene	<19 D	<27 D	<36 D	<8.9 D	<15 D	<19 D	<17 D

µg/kg micrograms per kilogram.

Italic Italicized result indicates analyte reported to the method detection limit.

Bold Bolded result indicates positively identified compound.

- Not analyzed.

D Sample dilution required for analysis; reported values reflect the dilution.

J Data are estimated due to associated quality control data.

T Analyte was positively identified but the reported concentration is estimated; reported concentration is less than the reporting limit, but greater than the method detection limit.

11/18/09

Table 4 Pesticides - Solids.xls

TABLE 4

PESTICIDES SOLID SAMPLE DATA SUMMARY
DEMONSTRATION TESTING AND FULL-SCALE OPERATION OF THE BIOGENESIS SEDIMENT DECONTAMINATION PROCESS
KEASBEY, NEW JERSEY
 (Page 10 of 23)

Field Sample Identification	TS-080206-1701	WS-080206-1702	RS-090206-2300	TS-090206-2301	WS-090206-2302	RS-130206-1700	TS-130206-1701
Sediment Source	Raritan River	Raritan River	Arthur Kill	Arthur Kill	Arthur Kill	Lower Paasic River	Lower Paasic River
Location Identification	TS	WS	RS	TS	WS	RS	TS
Date Collected	2/8/06	2/8/06	2/9/06	2/9/06	2/9/06	2/13/06	2/13/06
Matrix	Solid	Solid	Solid	Solid	Solid	Solid	Solid
Analyte/Methods (Units)							
Pesticides/SW80801A (µg/kg)							
Aldrin	<6.6 D	<15 D	6.3 TDJ	4.5 TDJ	7.8 TDJ	7.8 TD	5.5 TD
alpha BHC	<6.6 D	<15 D	<26 D	<13 D	<28 D	<35 D	<11 D
alpha Endosulfan	<6.6 D	<15 D	<26 D	<13 D	<28 D	<35 D	<11 D
alpha-Chlordane	<6.6 D	<15 D	7.6 TDJ	9.5 TDJ	12 TDJ	17 TD	12 D
beta BHC	<6.6 D	<15 D	<26 D	<13 D	<28 D	<35 D	<11 D
beta Endosulfan	<6.6 D	<15 D	21 TD	15 D	7.6 TDJ	<35 D	16 D
Chlordane	<66 D	<150 D	<260 D	<130 D	<280 D	<350 D	<110 D
delta BHC	<6.6 D	<15 D	<26 D	<13 D	<28 D	<35 D	<11 D
Dieldrin	1.2 TDJ	<15 D	13 TDJ	8.3 TDJ	20 TDJ	16 TD	7.1 TD
Endosulfan sulfate	<6.6 D	<15 D	<26 D	<13 D	<28 D	<35 D	<11 D
Endrin	<6.6 D	<15 D	2.9 TDJ	13 D	5.6 TDJ	6.0 TD	9.6 TD
Endrin aldehyde	<6.6 D	<15 D	<26 D	<13 D	<28 D	<35 D	<11 D
Endrin ketone	<6.6 D	<15 D	<26 D	<13 D	<28 D	<35 D	<11 D
gamma BHC (Lindane)	<6.6 D	<15 D	<26 D	<13 D	<28 D	<35 D	<11 D
gamma-Chlordane	<6.6 D	<15 D	9.3 TDJ	11 TD	13 TDJ	14 TD	21 D
Heptachlor	<6.6 D	<15 D	<26 D	<13 D	<28 D	<35 D	<11 D
Heptachlor epoxide	<6.6 D	<15 D	<26 D	<13 D	<28 D	<35 D	<11 D
Methoxychlor	<13 D	<29 D	270 D	210 D	<54 D	<68 D	77 D
p,p'-DDD	4.9 TD	9.6 TD	220 D	150 D	180 D	47 D	110 D
p,p'-DDE	5.1 TD	17 DJ	320 D	200 D	440 D	61 D	130 D
p,p'-DDT	9.3 D	<15 D	86 DJ	400 D	58 DJ	17 TD	110 D
Toxaphene	<8.8 D	<20 D	<35 D	<17 D	<37 D	<47 D	<15 D

µg/kg micrograms per kilogram.

Italic Italicized result indicates analyte reported to the method detection limit.

Bold Bolded result indicates positively identified compound.

- Not analyzed.

D Sample dilution required for analysis; reported values reflect the dilution.

J Data are estimated due to associated quality control data.

T Analyte was positively identified but the reported concentration is estimated; reported concentration is less than the reporting limit, but greater than the method detection limit.

11/18/09

Table 4 Pesticides - Solids.xls

TABLE 4

PESTICIDES SOLID SAMPLE DATA SUMMARY
DEMONSTRATION TESTING AND FULL-SCALE OPERATION OF THE BIOGENESIS SEDIMENT DECONTAMINATION PROCESS
KEASBEY, NEW JERSEY
 (Page 11 of 23)

Field Sample Identification	WS-130206-1702	RS-140206-1330	TS-140206-1331	WS-140206-1332	RS-160206-1500	TS-160206-1501	WS-160206-1502
Sediment Source	Lower Paasic River	Arthur Kill	Arthur Kill	Arthur Kill	Arthur Kill	Arthur Kill	Arthur Kill
Location Identification	WS	RS	TS	WS	RS	TS	WS
Date Collected	2/13/06	2/14/06	2/14/06	2/14/06	2/16/06	2/16/06	2/16/06
Matrix	Solid	Solid	Solid	Solid	Solid	Solid	Solid
Analyte/Methods (Units)							
Pesticides/SW80801A (µg/kg)							
Aldrin	6.3 TD	8.4 TD	7.3 TD	4.4 TD	<26 D	<13 D	<29 D
alpha BHC	<35 D	<33 D	<11 D	<31 D	<26 D	<13 D	<29 D
alpha Endosulfan	<35 D	<33 D	<11 D	<31 D	<26 D	<13 D	<29 D
alpha-Chlordane	6.8 TD	13 TD	7.9 TD	<31 D	4.9 TD	3.1 TD	7.0 TD
beta BHC	<35 D	<33 D	<11 D	<31 D	<26 D	<13 D	<29 D
beta Endosulfan	<35 D	25 TD	18 D	<31 D	14 TD	12 TD	<29 D
Chlordane	<350 D	<330 D	<110 D	<310 D	<260 D	<130 D	<290 D
delta BHC	<35 D	<33 D	<11 D	<31 D	<26 D	<13 D	<29 D
Dieldrin	23 TD	24 TD	4.6 TD	7.9 TD	14 TD	5.4 TD	9.6 TD
Endosulfan sulfate	<35 D	<33 D	<11 D	<31 D	<26 D	<13 D	<29 D
Endrin	<35 D	8.9 TD	6.7 TD	<31 D	2.9 TD	2.7 TD	4.1 TD
Endrin aldehyde	<35 D	<33 D	<11 D	<31 D	<26 D	<13 D	<29 D
Endrin ketone	<35 D	<33 D	<11 D	<31 D	<26 D	<13 D	<29 D
gamma BHC (Lindane)	<35 D	<33 D	<11 D	<31 D	<26 D	<13 D	<29 D
gamma-Chlordane	8.7 TD	15 TD	<11 D	4.6 TD	3.7 TD	2.3 TD	4.6 TD
Heptachlor	<35 D	<33 D	<11 D	<31 D	<26 D	<13 D	<29 D
Heptachlor epoxide	<35 D	<33 D	<11 D	<31 D	<26 D	<13 D	<29 D
Methoxychlor	54 TD	460 D	570 D	<60 D	210 D	480 D	48 TD
p,p'-DDD	150 D	240 D	140 D	56 D	140 D	86 D	95 D
p,p'-DDE	320 D	410 D	120 D	130 D	250 D	120 D	170 D
p,p'-DDT	71 D	100 D	200 D	19 TD	360 D	240 D	28 TD
Toxaphene	<47 D	<44 D	<15 D	<41 D	<35 D	<17 D	<39 D

µg/kg micrograms per kilogram.

Italic Italicized result indicates analyte reported to the method detection limit.

Bold Bolded result indicates positively identified compound.

- Not analyzed.

D Sample dilution required for analysis; reported values reflect the dilution.

J Data are estimated due to associated quality control data.

T Analyte was positively identified but the reported concentration is estimated; reported concentration is less than the reporting limit, but greater than the method detection limit.

11/18/09

Table 4 Pesticides - Solids.xls

TABLE 4

PESTICIDES SOLID SAMPLE DATA SUMMARY
DEMONSTRATION TESTING AND FULL-SCALE OPERATION OF THE BIOGENESIS SEDIMENT DECONTAMINATION PROCESS
KEASBEY, NEW JERSEY
 (Page 12 of 23)

Field Sample Identification	RS-170206-1100	TS-170206-1101	WS-170206-1102	TS-230206-0930	TS-230206-0930 DRIED	RS-270206-1400	TS-270206-1350
Sediment Source	Arthur Kill	Arthur Kill	Arthur Kill	Arthur Kill	Arthur Kill	Lower Passaic River	Lower Passaic River
Location Identification	RS	TS	WS	TS	TS	RS	TS
Date Collected	2/17/06	2/17/06	2/17/06	2/23/06	2/23/06	2/27/06	2/27/06
Matrix	Solid	Solid	Solid	Solid	Solid	Solid	Solid
Analyte/Methods (Units)							
Pesticides/SW80801A (µg/kg)							
Aldrin	9.2 TD	2.9 TD	5.6 TD	<12 D	<12 D	<140 D	<79 D
alpha BHC	<37 D	<12 D	<35 D	<12 D	<12 D	<140 D	<630 D
alpha Endosulfan	<37 D	<12 D	<35 D	<12 D	<12 D	<140 D	<630 D
alpha-Chlordane	9.6 TD	2.2 TD	<35 D	<12 D	<12 D	23 TD	<630 D
beta BHC	<37 D	<12 D	<35 D	<12 D	<12 D	<140 D	<630 D
beta Endosulfan	30 TD	<12 D	5.4 TD	<12 D	7.1 TD	35 TD	<630 D
Chlordane	<370 D	<120 D	<350 D	<120 D	<120 D	<1400 D	<6300 D
delta BHC	<37 D	<12 D	<35 D	<12 D	<12 D	<140 D	<630 D
Dieldrin	13 TD	4.8 TD	3.7 TD	5.3 TD	3.9 TD	34 TD	120 TD
Endosulfan sulfate	<37 D	<12 D	<35 D	<12 D	<12 D	<140 D	<630 D
Endrin	9.1 TD	4.0 TD	<35 D	<12 D	<12 D	33 TD	<630 D
Endrin aldehyde	<37 D	<12 D	<35 D	<12 D	<12 D	<140 D	<630 D
Endrin ketone	<37 D	<12 D	<35 D	<12 D	<12 D	<140 D	<630 D
gamma BHC (Lindane)	<37 D	<12 D	<35 D	<12 D	<12 D	<140 D	<630 D
gamma-Chlordane	5.4 TD	2.0 TD	<35 D	<12 D	<12 D	<140 D	<630 D
Heptachlor	<37 D	<12 D	<35 D	<12 D	<12 D	<140 D	<630 D
Heptachlor epoxide	<37 D	<12 D	<35 D	<12 D	<12 D	<140 D	<630 D
Methoxychlor	290 D	360 D	<67 D	300 D	230 D	140 TD	17000 D
p,p'-DDD	170 D	79 D	91 D	81 D	51 D	100 TD	<630 D
p,p'-DDE	360 D	110 D	260 D	90 D	59 D	110 TD	<630 D
p,p'-DDT	130 D	250 D	15 TD	300 D	160 D	100 TD	130 TD
Toxaphene	<49 D	<16 D	<46 D	<16 D	<16 D	<180 D	<840 D

µg/kg micrograms per kilogram.

Italic Italicized result indicates analyte reported to the method detection limit.

Bold Bolded result indicates positively identified compound.

- Not analyzed.

D Sample dilution required for analysis; reported values reflect the dilution.

J Data are estimated due to associated quality control data.

T Analyte was positively identified but the reported concentration is estimated; reported concentration is less than the reporting limit, but greater than the method detection limit.

11/18/09

Table 4 Pesticides - Solids.xls

TABLE 4

PESTICIDES SOLID SAMPLE DATA SUMMARY
DEMONSTRATION TESTING AND FULL-SCALE OPERATION OF THE BIOGENESIS SEDIMENT DECONTAMINATION PROCESS
KEASBEY, NEW JERSEY
 (Page 13 of 23)

Field Sample Identification	TS-270206-1350 DRIED	TS-270206-1630	TS-270206-1630 DRIED	RS-280206-1700	TS-280206-1705	WS-280206-1710	RS-010306-1700
Sediment Source	Lower Passaic River	Lower Passaic River	Lower Passaic River	Arthur Kill	Arthur Kill	Arthur Kill	Arthur Kill
Location Identification	TS	TS	TS	RS	TS	WS	RS
Date Collected	2/27/06	2/27/06	2/27/06	2/28/06	2/28/06	2/28/06	3/1/06
Matrix	Solid	Solid	Solid	Solid	Solid	Solid	Solid
Analyte/Methods (Units)							
Pesticides/SW80801A (µg/kg)							
Aldrin	<60 D	12 TD	8.5 TD	<35 D	<160 D	24 TD	<170 D
alpha BHC	<60 D	<61 D	<58 D	<280 D	<1300 D	<170 D	<170 D
alpha Endosulfan	<60 D	<61 D	<58 D	<280 D	<1300 D	<170 D	<170 D
alpha-Chlordane	8.7 TD	14 TD	11 TD	<280 D	<1300 D	<170 D	<170 D
beta BHC	<60 D	<61 D	<58 D	<280 D	<1300 D	<170 D	<170 D
beta Endosulfan	12 TD	20 TD	16 TD	<280 D	<1300 D	<170 D	<170 D
Chlordane	<600 D	<610 D	<580 D	<2800 D	<13000 D	<1700 D	<1700 D
delta BHC	<60 D	<61 D	<58 D	<280 D	<1300 D	<170 D	<170 D
Dieldrin	13 TD	16 TD	15 TD	<27 D	<120 D	34 TD	<170 D
Endosulfan sulfate	<60 D	<61 D	<58 D	<280 D	<1300 D	<170 D	<170 D
Endrin	6.1 TD	18 TD	15 TD	<280 D	<1300 D	78 TD	<170 D
Endrin aldehyde	<60 D	<61 D	<58 D	<280 D	<1300 D	<170 D	<170 D
Endrin ketone	<60 D	<61 D	<58 D	<280 D	<1300 D	<170 D	<170 D
gamma BHC (Lindane)	<60 D	<61 D	<58 D	<280 D	<1300 D	<170 D	<170 D
gamma-Chlordane	<60 D	9.8 TD	7.8 TD	<280 D	<1300 D	<170 D	<170 D
Heptachlor	<60 D	<61 D	<58 D	<280 D	<120 D	<170 D	<170 D
Heptachlor epoxide	<60 D	<61 D	<58 D	<280 D	<1300 D	<170 D	<170 D
Methoxychlor	270 D	160 D	120 D	6900 D	17000 D	1300 D	3200 D
p,p'-DDD	83 D	72 D	64 D	540 D	<1300 D	170 D	65 TD
p,p'-DDE	100 D	95 D	70 D	280 D	<1300 D	330 D	160 TD
p,p'-DDT	280 D	150 D	180 D	1100 D	260 TD	110 TD	180 D
Toxaphene	<80 D	<81 D	<77 D	<370 D	<1700 D	<220 D	<220 D

µg/kg micrograms per kilogram.

Italic Italicized result indicates analyte reported to the method detection limit.**Bold** Bolded result indicates positively identified compound.

- Not analyzed.

D Sample dilution required for analysis; reported values reflect the dilution.

J Data are estimated due to associated quality control data.

T Analyte was positively identified but the reported concentration is estimated; reported concentration is less than the reporting limit, but greater than the method detection limit.

11/18/09

Table 4 Pesticides - Solids.xls

TABLE 4

PESTICIDES SOLID SAMPLE DATA SUMMARY
DEMONSTRATION TESTING AND FULL-SCALE OPERATION OF THE BIOGENESIS SEDIMENT DECONTAMINATION PROCESS
KEASBEY, NEW JERSEY
 (Page 14 of 23)

Field Sample Identification	TS-010306-1705	WS-010306-1710	SS-020306-1400	RS-020306-1700	TS-020306-1705	WS-020306-1710	RS-030306-1200
Sediment Source	Arthur Kill	Arthur Kill	Arthur Kill	Arthur Kill	Arthur Kill	Arthur Kill	Arthur Kill
Location Identification	TS	WS	SS1	RS	TS	WS	RS
Date Collected	3/1/06	3/1/06	3/2/06	3/2/06	3/2/06	3/2/06	3/3/06
Matrix	Solid	Solid	Solid	Solid	Solid	Solid	Solid
Analyte/Methods (Units)							
Pesticides/SW80801A (µg/kg)							
Aldrin	<42 D	2.8 TD	<560 D	<44 D	<89 D	<40 D	<25 D
alpha BHC	<340 D	<16 D	<4500 D	<360 D	<720 D	<320 D	<200 D
alpha Endosulfan	<340 D	<16 D	<4500 D	<360 D	<720 D	<320 D	<200 D
alpha-Chlordane	<340 D	5.3 TD	<4500 D	<360 D	<720 D	<320 D	<200 D
beta BHC	<340 D	<16 D	<4500 D	<360 D	<720 D	<320 D	<200 D
beta Endosulfan	<340 D	12 TD	<4500 D	89 TD	<720 D	<320 D	<200 D
Chlordane	<3400 D	<160 D	<45000 D	<3600 D	<7200 D	<3200 D	<2000 D
delta BHC	<340 D	<16 D	<4500 D	<360 D	<720 D	<320 D	<200 D
Dieldrin	<32 D	6.7 TD	<420 D	<34 D	<68 D	<31 D	<19 D
Endosulfan sulfate	<340 D	<16 D	<4500 D	<360 D	<720 D	<320 D	<200 D
Endrin	<340 D	<16 D	<4500 D	43 TD	<720 D	43 TD	<200 D
Endrin aldehyde	<340 D	<16 D	<4500 D	<360 D	<720 D	<320 D	<200 D
Endrin ketone	<340 D	<16 D	<4500 D	<360 D	<720 D	<320 D	<200 D
gamma BHC (Lindane)	<340 D	<16 D	<370 D	<360 D	<720 D	<320 D	<200 D
gamma-Chlordane	<340 D	<16 D	<4500 D	<360 D	<720 D	<320 D	<200 D
Heptachlor	<340 D	<16 D	<420 D	<360 D	<68 D	<320 D	<200 D
Heptachlor epoxide	<340 D	<16 D	<4500 D	<360 D	<720 D	<320 D	<200 D
Methoxychlor	7300 D	310 D	63000 D	14000 D	14000 D	1200 D	3800 D
p,p'-DDD	66 TD	54 D	<4500 D	110 TD	110 TD	130 TD	33 TD
p,p'-DDE	110 TD	130 D	<4500 D	200 TD	160 TD	310 TD	44 TD
p,p'-DDT	140 TD	24 D	<4500 D	74 TD	270 TD	<320 D	47 TD
Toxaphene	<450 D	<21 D	<5900 D	<470 D	<950 D	<430 D	<270 D

µg/kg micrograms per kilogram.

Italic Italicized result indicates analyte reported to the method detection limit.

Bold Bolded result indicates positively identified compound.

- Not analyzed.

D Sample dilution required for analysis; reported values reflect the dilution.

J Data are estimated due to associated quality control data.

T Analyte was positively identified but the reported concentration is estimated; reported concentration is less than the reporting limit, but greater than the method detection limit.

11/18/09

Table 4 Pesticides - Solids.xls

TABLE 4
PESTICIDES SOLID SAMPLE DATA SUMMARY
DEMONSTRATION TESTING AND FULL-SCALE OPERATION OF THE BIOGENESIS SEDIMENT DECONTAMINATION PROCESS
KEASBEY, NEW JERSEY
 (Page 15 of 23)

Field Sample Identification	TS-030306-1205	WS-030306-1210	RS-060406-1215	TS-060406-1240	WS-060406-1300	RS-100406-1525	TS-100406-1615
Sediment Source	Arthur Kill	Arthur Kill	Arthur Kill	Arthur Kill	Arthur Kill	Arthur Kill	Arthur Kill
Location Identification	TS	WS	RS	TS	WS	RS	TS
Date Collected	3/3/06	3/3/06	4/6/06	4/6/06	4/6/06	4/10/06	4/10/06
Matrix	Solid	Solid	Solid	Solid	Solid	Solid	Solid
Analyte/Methods (Units)							
Pesticides/SW80801A (µg/kg)							
Aldrin	<150 D	<150 D	6.9 TD	<130 D	<32 D	<36 D	<130 D
alpha BHC	<150 D	<150 D	<29 D	<130 D	<32 D	<290 D	<130 D
alpha Endosulfan	<150 D	<150 D	<29 D	<130 D	<32 D	<290 D	<130 D
alpha-Chlordane	<150 D	<150 D	17 TD	<130 D	15 TD	<290 D	<130 D
beta BHC	<150 D	<150 D	<29 D	<130 D	<32 D	<290 D	<130 D
beta Endosulfan	41 TD	<150 D	24 TD	<130 D	6.8 TD	63 TD	<130 D
Chlordane	<1500 D	<1500 D	<290 D	<1300 D	<320 D	<2900 D	<1300 D
delta BHC	<150 D	<150 D	<29 D	<130 D	<32 D	<290 D	<130 D
Dieldrin	<150 D	<150 D	9.2 TD	<130 D	<32 D	<27 D	<130 D
Endosulfan sulfate	<150 D	<150 D	<29 D	<130 D	<32 D	<290 D	<130 D
Endrin	34 TD	<150 D	37 D	<130 D	31 TD	30 TD	<130 D
Endrin aldehyde	<150 D	<150 D	<29 D	<130 D	<32 D	<290 D	<130 D
Endrin ketone	<150 D	<150 D	<29 D	<130 D	<32 D	<290 D	<130 D
gamma BHC (Lindane)	<150 D	<150 D	<29 D	<130 D	<32 D	<290 D	<130 D
gamma-Chlordane	<150 D	<150 D	14 TD	<130 D	<32 D	<290 D	<130 D
Heptachlor	<150 D	<150 D	<29 D	<130 D	<32 D	<290 D	<130 D
Heptachlor epoxide	<150 D	<150 D	<29 D	<130 D	<32 D	<290 D	<130 D
Methoxychlor	8900 D	210 TD	2000 D	3400 D	590 D	2000 D	3500 D
p,p'-DDD	93 TD	38 TD	<29 D	210 D	<32 D	210 TDJ	110 TDJ
p,p'-DDE	100 TD	50 TD	290 D	190 D	290 D	240 TD	120 TD
p,p'-DDT	330 D	<150 D	430 D	610 D	130 D	310 D	640 D
Toxaphene	<190 D	<200 D	<39 D	<170 D	<43 D	<380 D	<170 D

µg/kg micrograms per kilogram.

Italic Italicized result indicates analyte reported to the method detection limit.

Bold Bolded result indicates positively identified compound.

- Not analyzed.

D Sample dilution required for analysis; reported values reflect the dilution.

J Data are estimated due to associated quality control data.

T Analyte was positively identified but the reported concentration is estimated; reported concentration is less than the reporting limit, but greater than the method detection limit.

11/18/09

Table 4 Pesticides - Solids.xls

TABLE 4

PESTICIDES SOLID SAMPLE DATA SUMMARY
DEMONSTRATION TESTING AND FULL-SCALE OPERATION OF THE BIOGENESIS SEDIMENT DECONTAMINATION PROCESS
KEASBEY, NEW JERSEY
 (Page 16 of 23)

Field Sample Identification	WS-100406-1630	RS-120406-1815	TS-120406-1835	WS-120406-1840	RS-170406-1725	TS-170406-1745	WS-170406-1745
Sediment Source	Arthur Kill	Arthur Kill	Arthur Kill	Arthur Kill	Arthur Kill	Arthur Kill	Arthur Kill
Location Identification	WS	RS	TS	WS	RS	TS	WS
Date Collected	4/10/06	4/12/06	4/12/06	4/12/06	4/17/06	4/17/06	4/17/06
Matrix	Solid	Solid	Solid	Solid	Solid	Solid	Solid
Analyte/Methods (Units)							
Pesticides/SW80801A (µg/kg)							
Aldrin	<41 D	<37 D	<130 D	<37 D	<35 D	<120 D	<37 D
alpha BHC	<330 D	<300 D	<130 D	<300 D	<280 D	<120 D	<300 D
alpha Endosulfan	<330 D	<300 D	<130 D	250 TD	<280 D	<120 D	<300 D
alpha-Chlordane	<330 D	<300 D	<130 D	<300 D	<280 D	<120 D	<300 D
beta BHC	<330 D	<300 D	<130 D	<300 D	<280 D	<120 D	<300 D
beta Endosulfan	<330 D	55 TD	26 TD	<300 D	61 TD	60 TD	87 TD
Chlordane	<3300 D	<3000 D	<1300 D	<3000 D	<2800 D	<1200 D	<3000 D
delta BHC	<330 D	<300 D	<130 D	<300 D	<280 D	<120 D	<300 D
Dieldrin	<31 D	<28 D	<130 D	<28 D	<27 D	18 TD	50 TD
Endosulfan sulfate	<330 D	<300 D	<130 D	<300 D	<280 D	<120 D	<300 D
Endrin	44 TD	<300 D	<130 D	<300 D	52 TD	39 TD	54 TD
Endrin aldehyde	<330 D	<300 D	<130 D	<300 D	<280 D	<120 D	<300 D
Endrin ketone	<330 D	<300 D	<130 D	<300 D	<280 D	<120 D	<300 D
gamma BHC (Lindane)	<330 D	<300 D	<130 D	<300 D	<280 D	<120 D	<300 D
gamma-Chlordane	<330 D	<300 D	<130 D	<300 D	<280 D	<120 D	<300 D
Heptachlor	<330 D	<300 D	<130 D	<300 D	<280 D	<120 D	<300 D
Heptachlor epoxide	<330 D	<300 D	<130 D	<300 D	<280 D	<120 D	<300 D
Methoxychlor	370 TD	2200 D	4800 D	850 D	650 D	2100 D	490 TD
p,p'-DDD	190 TDJ	200 TD	180 D	280 TD	280 D	250 D	490 D
p,p'-DDE	230 TD	280 TD	190 D	540 D	340 D	220 D	750 D
p,p'-DDT	200 TD	250 TD	650 D	180 TD	940 D	1100 D	320 D
Toxaphene	<430 D	<400 D	<170 D	<400 D	<370 D	<160 D	<400 D

µg/kg micrograms per kilogram.

Italic Italicized result indicates analyte reported to the method detection limit.

Bold Bolded result indicates positively identified compound.

- Not analyzed.

D Sample dilution required for analysis; reported values reflect the dilution.

J Data are estimated due to associated quality control data.

T Analyte was positively identified but the reported concentration is estimated; reported concentration is less than the reporting limit, but greater than the method detection limit.

11/18/09

Table 4 Pesticides - Solids.xls

TABLE 4

PESTICIDES SOLID SAMPLE DATA SUMMARY
DEMONSTRATION TESTING AND FULL-SCALE OPERATION OF THE BIOGENESIS SEDIMENT DECONTAMINATION PROCESS
KEASBEY, NEW JERSEY
 (Page 17 of 23)

Field Sample Identification	PSS-200406-1600	RS-200406-1615	TS-200406-1635	WS-200406-1640	RS-250406-1815	TS-250406-1835	WS-250406-1840
Sediment Source	Arthur Kill	Arthur Kill	Arthur Kill	Arthur Kill	Arthur Kill	Arthur Kill	Arthur Kill
Location Identification	PSS	RS	TS	WS	RS	TS	WS
Date Collected	4/20/06	4/20/06	4/20/06	4/20/06	4/25/06	4/25/06	4/25/06
Matrix	Solid	Solid	Solid	Solid	Solid	Solid	Solid
Analyte/Methods (Units)							
Pesticides/SW80801A (µg/kg)							
Aldrin	<140 D	<44 D	<120 D	<38 D	<55 D	<63 D	<140 D
alpha BHC	<140 D	<350 D	<120 D	<300 D	<55 D	<63 D	<140 D
alpha Endosulfan	<140 D	<350 D	<120 D	<300 D	<55 D	<63 D	<140 D
alpha-Chlordane	<140 D	<350 D	<120 D	<300 D	17 TD	11 TD	22 TD
beta BHC	<140 D	<350 D	<120 D	<300 D	<55 D	<63 D	<140 D
beta Endosulfan	<140 D	<350 D	54 TD	100 TD	48 TD	49 TD	32 TD
Chlordane	<1400 D	<3500 D	<1200 D	<3000 D	<550 D	<630 D	<1400 D
delta BHC	<140 D	<350 D	<120 D	<300 D	<55 D	<63 D	<140 D
Dieldrin	<140 D	<34 D	16 TD	<29 D	13 TD	11 TD	<140 D
Endosulfan sulfate	<140 D	<350 D	<120 D	<300 D	<55 D	<63 D	<140 D
Endrin	34 TD	40 TD	19 TD	<300 D	46 TD	36 TD	36 TD
Endrin aldehyde	<140 D	<350 D	<120 D	<300 D	26 TD	<63 D	<140 D
Endrin ketone	<140 D	<350 D	<120 D	<300 D	<55 D	<63 D	<140 D
gamma BHC (Lindane)	<140 D	<350 D	<120 D	<300 D	<55 D	<63 D	<140 D
gamma-Chlordane	<140 D	<350 D	<120 D	<300 D	11 TD	<63 D	<140 D
Heptachlor	<140 D	<350 D	<120 D	<300 D	<55 D	<63 D	<140 D
Heptachlor epoxide	<140 D	<350 D	<120 D	<300 D	<55 D	<63 D	<140 D
Methoxychlor	1100 D	1600 D	1900 D	160 TD	1900 D	2900 D	670 D
p,p'-DDD	290 D	240 TD	250 D	270 TD	250 D	190 D	240 D
p,p'-DDE	310 D	340 TD	180 D	300 D	330 D	190 D	450 D
p,p'-DDT	480 D	300 TD	700 D	230 TD	1700 D	670 D	140 D
Toxaphene	<75 D	<470 D	<160 D	<400 D	<74 D	<84 D	<190 D

µg/kg micrograms per kilogram.

Italic Italicized result indicates analyte reported to the method detection limit.

Bold Bolded result indicates positively identified compound.

- Not analyzed.

D Sample dilution required for analysis; reported values reflect the dilution.

J Data are estimated due to associated quality control data.

T Analyte was positively identified but the reported concentration is estimated; reported concentration is less than the reporting limit, but greater than the method detection limit.

11/18/09

Table 4 Pesticides - Solids.xls

TABLE 4

PESTICIDES SOLID SAMPLE DATA SUMMARY
DEMONSTRATION TESTING AND FULL-SCALE OPERATION OF THE BIOGENESIS SEDIMENT DECONTAMINATION PROCESS
KEASBEY, NEW JERSEY
 (Page 18 of 23)

Field Sample Identification	RS-270406-1715	TS-270406-1735	WS-270406-1740	PSS-010506-1600	RS-010506-1615	TS-010506-1635	TS3-010506-1630
Sediment Source	Arthur Kill	Arthur Kill	Arthur Kill	Lower Passaic River	Lower Passaic River	Lower Passaic River	Lower Passaic River
Location Identification	RS	TS	WS	PSS	RS	TS	TS3
Date Collected	4/27/06	4/27/06	4/27/06	5/1/06	5/1/06	5/1/06	5/1/06
Matrix	Solid	Solid	Solid	Solid	Solid	Solid	Solid
Analyte/Methods (Units)							
Pesticides/SW80801A (µg/kg)							
Aldrin	<130 D	<65 D	<170 D	<26 D	<22 D	<68 D	<66 D
alpha BHC	<130 D	<65 D	<170 D	<210 D	<180 D	<68 D	<66 D
alpha Endosulfan	<130 D	<65 D	<170 D	<210 D	<180 D	<68 D	<66 D
alpha-Chlordane	<130 D	<65 D	<170 D	<210 D	<180 D	<68 D	<66 D
beta BHC	<130 D	<65 D	<170 D	<210 D	<180 D	<68 D	<66 D
beta Endosulfan	<130 D	42 TD	<170 D	<210 D	<180 D	37 TD	71 D
Chlordane	<1300 D	<650 D	<1700 D	<2100 D	<1800 D	<680 D	<660 D
delta BHC	15 TD	<65 D	<170 D	<210 D	<180 D	<68 D	<66 D
Dieldrin	<130 D	14 TD	<170 D	<20 D	<180 D	<68 D	20 TD
Endosulfan sulfate	<130 D	<65 D	<170 D	<210 D	<180 D	<68 D	<66 D
Endrin	24 TD	25 TD	48 TD	42 TD	61 TD	49 TD	36 TD
Endrin aldehyde	430 D	15 TD	52 TD	<210 D	<180 D	22 TD	21 TD
Endrin ketone	<130 D	<65 D	<170 D	<210 D	<180 D	<68 D	<66 D
gamma BHC (Lindane)	<130 D	<65 D	<170 D	<210 D	<180 D	<68 D	<66 D
gamma-Chlordane	<130 D	<65 D	<170 D	<210 D	<180 D	<68 D	<66 D
Heptachlor	<130 D	<65 D	<170 D	<210 D	<180 D	<68 D	<66 D
Heptachlor epoxide	<130 D	<65 D	<170 D	<210 D	<180 D	<68 D	<66 D
Methoxychlor	190 TD	930 D	410 D	<410 D	<350 D	44 TD	40 TD
p,p'-DDD	150 D	210 D	340 D	30 TD	45 TD	62 TD	96 D
p,p'-DDE	260 D	210 D	700 D	69 TD	64 TD	110 D	79 D
p,p'-DDT	170 D	870 D	250 D	<210 D	44 TD	160 D	240 D
Toxaphene	<170 D	<86 D	<230 D	<56 D	<240 D	<91 D	<88 D

µg/kg micrograms per kilogram.

Italic Italicized result indicates analyte reported to the method detection limit.

Bold Bolded result indicates positively identified compound.

- Not analyzed.

D Sample dilution required for analysis; reported values reflect the dilution.

J Data are estimated due to associated quality control data.

T Analyte was positively identified but the reported concentration is estimated; reported concentration is less than the reporting limit, but greater than the method detection limit.

11/18/09

Table 4 Pesticides - Solids.xls

TABLE 4

PESTICIDES SOLID SAMPLE DATA SUMMARY
DEMONSTRATION TESTING AND FULL-SCALE OPERATION OF THE BIOGENESIS SEDIMENT DECONTAMINATION PROCESS
KEASBEY, NEW JERSEY
 (Page 19 of 23)

Field Sample Identification	WS-010506-1640	PSS-030506-1600	RS-030506-1615	TS-030506-1635	STS-3-030506-1200	STS-4-030506-1400	WS-030506-1640
Sediment Source	Lower Passaic River	Lower Passaic River	Lower Passaic River	Lower Passaic River	Lower Passaic River	Lower Passaic River	Lower Passaic River
Location Identification	WS	PSS	RS	TS	TS	TS	WS
Date Collected	5/1/06	5/3/06	5/3/06	5/3/06	5/3/06	5/3/06	5/3/06
Matrix	Solid	Solid	Solid	Solid	Solid	Solid	Solid
Analyte/Methods (Units)							
Pesticides/SW80801A (µg/kg)							
Aldrin	<160 D	<160 D	<160 D	<62 D	<64 D	<64 D	<160 D
alpha BHC	<160 D	<160 D	<160 D	<62 D	<64 D	<64 D	<160 D
alpha Endosulfan	<160 D	<160 D	<160 D	<62 D	<64 D	<64 D	<160 D
alpha-Chlordane	<160 D	<160 D	<160 D	<62 D	<64 D	<64 D	<160 D
beta BHC	<160 D	<160 D	<160 D	<62 D	<64 D	<64 D	<160 D
beta Endosulfan	130 TD	110 TD	<160 D	74 D	75 D	88 D	110 TD
Chlordane	<1600 D	<1600 D	<1600 D	<620 D	<640 D	<640 D	<1600 D
delta BHC	<160 D	<160 D	<160 D	<62 D	<64 D	<64 D	<160 D
Dieldrin	58 TD	44 TD	<160 D	34 TD	41 TD	22 TD	40 TD
Endosulfan sulfate	<160 D	<160 D	<160 D	<62 D	<64 D	<64 D	<160 D
Endrin	38 TD	130 TD	43 TD	89 D	92 D	37 TD	85 TD
Endrin aldehyde	<160 D	<160 D	<160 D	<62 D	<64 D	<64 D	<160 D
Endrin ketone	<160 D	<160 D	<160 D	<62 D	<64 D	<64 D	<160 D
gamma BHC (Lindane)	<160 D	20 TD	<160 D	<62 D	<64 D	<64 D	<160 D
gamma-Chlordane	<160 D	<160 D	<160 D	<62 D	<64 D	<64 D	<160 D
Heptachlor	<160 D	<160 D	<160 D	<62 D	<64 D	<64 D	<160 D
Heptachlor epoxide	<160 D	<160 D	<160 D	<62 D	<64 D	<64 D	<160 D
Methoxychlor	<310 D	<310 D	<320 D	<120 D	<120 D	<120 D	<320 D
p,p'-DDD	270 D	350 D	30 TD	98 D	100 D	96 D	140 TD
p,p'-DDE	330 D	120 TD	81 TD	89 D	93 D	80 D	97 TD
p,p'-DDT	190 D	170 D	51 TD	120 D	150 D	110 D	160 D
Toxaphene	<210 D	<21 D	<220 D	<83 D	<86 D	<85 D	<220 D

µg/kg micrograms per kilogram.

Italic Italicized result indicates analyte reported to the method detection limit.

Bold Bolded result indicates positively identified compound.

- Not analyzed.

D Sample dilution required for analysis; reported values reflect the dilution.

J Data are estimated due to associated quality control data.

T Analyte was positively identified but the reported concentration is estimated; reported concentration is less than the reporting limit, but greater than the method detection limit.

11/18/09

Table 4 Pesticides - Solids.xls

TABLE 4

PESTICIDES SOLID SAMPLE DATA SUMMARY
DEMONSTRATION TESTING AND FULL-SCALE OPERATION OF THE BIOGENESIS SEDIMENT DECONTAMINATION PROCESS
KEASBEY, NEW JERSEY
 (Page 20 of 23)

Field Sample Identification	SPC COMP- 160506-1700	SPP COMP- 170506-1030	MSL01-040107- 0905	MSL02-040107- 0925	MSL03-040107- 0940	MSL04-040107- 0950	MSL05-040107- 1000
Sediment Source	All	All	Lower Passaic River	Lower Passaic River	Lower Passaic River	Lower Passaic River	Lower Passaic River
Location Identification	TSP	TSP	MSL	MSL	MSL	MSL	MSL
Date Collected	5/16/06	5/17/06	1/4/07	1/4/07	1/4/07	1/4/07	1/4/07
Matrix	Solid	Solid	Solid	Solid	Solid	Solid	Solid
Analyte/Methods (Units)							
Pesticides/SW80801A (µg/kg)							
Aldrin	<62 D	<48 D	<5.3 D	<5.3 D	<5.5 D	<5.3 D	1.1 TD
alpha BHC	<62 D	<48 D	<5.3 D	<5.3 D	<5.5 D	<5.3 D	<5.2 D
alpha Endosulfan	<62 D	<48 D	<5.3 D	<5.3 D	<5.5 D	<5.3 D	<5.2 D
alpha-Chlordane	<62 D	<48 D	8.1 D	7.8 D	3.5 TD	3.6 TD	<5.2 D
beta BHC	<62 D	<48 D	<5.3 D	<5.3 D	<5.5 D	<5.3 D	<5.2 D
beta Endosulfan	<62 D	51 D	<5.3 D	<5.3 D	<5.5 D	<5.3 D	<5.2 D
Chlordane	<620 D	<480 D	<53 D	<53 D	<55 D	<53 D	<52 D
delta BHC	<62 D	<48 D	<5.3 D	<5.3 D	<5.5 D	<5.3 D	<5.2 D
Dieldrin	37 TDJ	10 TDJ	<5.3 D	<5.3 D	<5.5 D	<5.3 D	<5.2 D
Endosulfan sulfate	<62 D	<48 D	<5.3 D	<5.3 D	<5.5 D	<5.3 D	<5.2 D
Endrin	18 TDJ	26 TDJ	3.7 TD	2.9 TD	0.71 TD	0.96 TD	0.71 TD
Endrin aldehyde	<62 D	17 TDJ	4.0 TD	8.2 D	6.6 D	3.1 TD	6.4 D
Endrin ketone	<62 D	<48 D	<5.3 D	<5.3 D	<5.5 D	<5.3 D	<5.2 D
gamma BHC (Lindane)	<62 D	<48 D	<5.3 D	<5.3 D	<5.5 D	<5.3 D	<5.2 D
gamma-Chlordane	<62 D	<48 D	<5.3 D	<5.3 D	3.3 TD	<5.3 D	2.2 TDJ
Heptachlor	<62 D	<48 D	<5.3 D	<5.3 D	<5.5 D	<5.3 D	<5.2 D
Heptachlor epoxide	<62 D	<48 D	1.8 TD	1.2 TD	1.1 TD	0.78 TD	1.1 TD
Methoxychlor	1800 D	89 TDJ	83 D	64 D	88 D	48 D	100 D
p,p'-DDD	190 D	70 D	38 D	39 D	35 D	65 D	34 DJ
p,p'-DDE	180 D	51 D	36 D	35 D	36 D	28 D	32 D
p,p'-DDT	260 D	84 D	49 D	40 D	38 D	32 D	42 D
Toxaphene	<2500 D	<1900 D	<210 D	<210 D	<220 D	<210 D	<200 D

µg/kg micrograms per kilogram.

Italic Italicized result indicates analyte reported to the method detection limit.**Bold** Bolded result indicates positively identified compound.

- Not analyzed.

D Sample dilution required for analysis; reported values reflect the dilution.

J Data are estimated due to associated quality control data.

T Analyte was positively identified but the reported concentration is estimated; reported concentration is less than the reporting limit, but greater than the method detection limit.

11/18/09

Table 4 Pesticides - Solids.xls

TABLE 4

PESTICIDES SOLID SAMPLE DATA SUMMARY
DEMONSTRATION TESTING AND FULL-SCALE OPERATION OF THE BIOGENESIS SEDIMENT DECONTAMINATION PROCESS
KEASBEY, NEW JERSEY
 (Page 21 of 23)

Field Sample Identification	MSL06-040107-1015	MSL07-040107-1025	MSL08-040107-1035	MSL09-040107-1045	MSL10-040107-1055	MSL11-040107-1055	PR-A-040107-0905
Sediment Source	Lower Passaic River	Lower Passaic River	Lower Passaic River	Lower Passaic River	Lower Passaic River	Lower Passaic River	Lower Passaic River
Location Identification	MSL	MSL	MSL	MSL	MSL	MSL	MSL
Date Collected	1/4/07	1/4/07	1/4/07	1/4/07	1/4/07	1/4/07	1/4/07
Matrix	Solid	Solid	Solid	Solid	Solid	Solid	Solid
Analyte/Methods (Units)							
Pesticides/SW80801A (µg/kg)							
Aldrin	<5.5 D	<53 D	<5.3 D	<5.5 D	<5.4 D	<5.3 D	<53 D
alpha BHC	<5.5 D	<53 D	<5.3 D	<5.5 D	<5.4 D	<5.3 D	<53 D
alpha Endosulfan	<5.5 D	<53 D	<5.3 D	<5.5 D	<5.4 D	<5.3 D	<53 D
alpha-Chlordane	7.4 D	<53 D	2.9 TD	8.3 D	3.2 TD	2.8 TD	<53 D
beta BHC	<5.5 D	<53 D	<5.3 D	<5.5 D	<5.4 D	<5.3 D	<53 D
beta Endosulfan	<5.5 D	<53 D	<5.3 D	<5.5 D	<5.4 D	<5.3 D	<53 D
Chlordane	<55 D	<530 D	<53 D	<55 D	<54 D	<53 D	-
delta BHC	<5.5 D	<53 D	<5.3 D	<5.5 D	<5.4 D	<5.3 D	<53 D
Dieldrin	<5.5 D	<53 D	<5.3 D	1.6 TD	<5.4 D	<5.3 D	<53 D
Endosulfan sulfate	<5.5 D	<53 D	<5.3 D	<5.5 D	<5.4 D	<5.3 D	<53 D
Endrin	3.3 TD	<53 D	1.5 TD	0.87 TD	1.2 TD	1.2 TD	<53 D
Endrin aldehyde	8.3 D	<53 D	8.5 D	7.3 D	6.1 D	8.5 D	28 TD
Endrin ketone	<5.5 D	<53 D	<5.3 D	<5.5 D	<5.4 D	<5.3 D	<53 D
gamma BHC (Lindane)	<5.5 D	<53 D	<5.3 D	<5.5 D	<5.4 D	<5.3 D	<53 D
gamma-Chlordane	5.9 D	<53 D	1.9 TD	6.7 D	2.6 TD	2.3 TD	<53 D
Heptachlor	<5.5 D	<53 D	<5.3 D	<5.5 D	<5.4 D	<5.3 D	<53 D
Heptachlor epoxide	1.3 TD	<53 D	0.83 TD	1.4 TD	1.1 TD	1.0 TD	<53 D
Methoxychlor	63 D	1100 D	42 D	18 D	71 D	27 D	220 D
p,p'-DDD	39 D	19 TD	28 D	24 D	35 D	26 D	73 DJ
p,p'-DDE	33 D	19 TD	27 D	26 D	37 D	25 D	62 D
p,p'-DDT	34 D	30 TD	69 D	36 D	190 D	24 D	79 D
Toxaphene	<210 D	<2100 D	<210 D	<220 D	<210 D	<210 D	<2100 D

µg/kg micrograms per kilogram.

Italic Italicized result indicates analyte reported to the method detection limit.**Bold** Bolded result indicates positively identified compound.

- Not analyzed.

D Sample dilution required for analysis; reported values reflect the dilution.

J Data are estimated due to associated quality control data.

T Analyte was positively identified but the reported concentration is estimated; reported concentration is less than the reporting limit, but greater than the method detection limit.

11/18/09

Table 4 Pesticides - Solids.xls

TABLE 4

PESTICIDES SOLID SAMPLE DATA SUMMARY
DEMONSTRATION TESTING AND FULL-SCALE OPERATION OF THE BIOGENESIS SEDIMENT DECONTAMINATION PROCESS
KEASBEY, NEW JERSEY
 (Page 22 of 23)

Field Sample Identification	PR-B-040107-0940	PR-C-040107-1035	PR-D-040107-1055	TS1-121908-0800	AD1-121908-0830	AD2-121908-0820	AD3-121908-0840
Sediment Source	Lower Passaic River	Lower Passaic River	Lower Passaic River	Lower Passaic River	None	None	None
Location Identification	MSL	MSL	MSL	TS	AD	AD	AD
Date Collected	1/4/07	1/4/07	1/4/07	12/19/08	12/19/08	12/19/08	12/19/08
Matrix	Solid	Solid	Solid	Solid	Solid	Solid	Solid
Analyte/Methods (Units)							
Pesticides/SW80801A (µg/kg)							
Aldrin	<53 D	<54 D	<55 D	<11 D	<1.8	<1.8	<2.5
alpha BHC	<53 D	<54 D	<55 D	<11 D	<1.8	<1.8	<2.5
alpha Endosulfan	<53 D	<54 D	<55 D	<11 D	<1.8	<1.8	<2.5
alpha-Chlordane	<53 D	<54 D	<55 D	3.0 TDJ	<1.8	<1.8	<2.5
beta BHC	<53 D	<54 D	<55 D	<11 D	<1.8	<1.8	<2.5
beta Endosulfan	<53 D	<54 D	<55 D	<11 D	<1.8	<1.8	1.4 TJ
Chlordane	-	-	-	<110 D	<1.8	<1.8	<2.5
delta BHC	<53 D	<54 D	<55 D	<11 D	<1.8	<1.8	<2.5
Dieldrin	<53 D	<54 D	<55 D	21 DJ	<1.8	<1.8	<2.5
Endosulfan sulfate	<53 D	<54 D	<55 D	<11 D	<1.8	<1.8	3.1 J
Endrin	<53 D	<54 D	<55 D	8.5 TDJ	<1.8	<1.8	<2.5
Endrin aldehyde	12 TDJ	<54 D	34 TD	<11 D	<1.8	<1.8	2.1 T
Endrin ketone	<53 D	<54 D	<55 D	<11 D	<1.8	<1.8	2.8 J
gamma BHC (Lindane)	<53 D	<54 D	<55 D	<11 D	<1.8	<1.8	<2.5
gamma-Chlordane	<53 D	<54 D	<55 D	56 D	<1.8	<1.8	<2.5
Heptachlor	<53 D	<54 D	<55 D	<11 D	<1.8	<1.8	<2.5
Heptachlor epoxide	<53 D	<54 D	<55 D	3.3 TDJ	0.65 TJ	<1.8	1.3 T
Methoxychlor	100 D	240 D	590 D	380 D	<3.5	<3.4	<4.8
p,p'-DDD	70 DJ	56 DJ	69 DJ	49 D	<1.8	<1.8	1.4 T
p,p'-DDE	63 D	51 TD	66 D	32 DJ	<1.8	<1.8	<2.5
p,p'-DDT	70 DJ	36 TDJ	58 DJ	55 D	<1.8	<1.8	2.2 TJ
Toxaphene	<2100 D	<2100 D	<2200 D	<440 D	<70	<69	<98

µg/kg micrograms per kilogram.

Italic Italicized result indicates analyte reported to the method detection limit.

Bold Bolded result indicates positively identified compound.

- Not analyzed.

D Sample dilution required for analysis; reported values reflect the dilution.

J Data are estimated due to associated quality control data.

T Analyte was positively identified but the reported concentration is estimated; reported concentration is less than the reporting limit, but greater than the method detection limit.

11/18/09

Table 4 Pesticides - Solids.xls

TABLE 4

PESTICIDES SOLID SAMPLE DATA SUMMARY
DEMONSTRATION TESTING AND FULL-SCALE OPERATION OF THE BIOGENESIS SEDIMENT DECONTAMINATION PROCESS
KEASBEY, NEW JERSEY
 (Page 23 of 23)

Field Sample Identification		MS1-121908-0850
Sediment Source	Lower Passaic River	
Location Identification	MSL	
Date Collected	12/19/08	
Matrix	Solid	
Analyte/Methods (Units)		
Pesticides/SW80801A (µg/kg)		
Aldrin	<4.3 D	
alpha BHC	<4.3 D	
alpha Endosulfan	<4.3 D	
alpha-Chlordane	<4.3 D	
beta BHC	<4.3 D	
beta Endosulfan	<4.3 D	
Chlordane	<4.3 D	
delta BHC	<4.3 D	
Dieldrin	2.9 TDJ	
Endosulfan sulfate	<4.3 D	
Endrin	<4.3 D	
Endrin aldehyde	<4.3 D	
Endrin ketone	<4.3 D	
gamma BHC (Lindane)	<4.3 D	
gamma-Chlordane	8.0 DJ	
Heptachlor	<4.3 D	
Heptachlor epoxide	<4.3 D	
Methoxychlor	98 D	
p,p'-DDD	2.9 TDJ	
p,p'-DDE	6.2 DJ	
p,p'-DDT	4.5 D	
Toxaphene	<170 D	

µg/kg micrograms per kilogram.

Italic Italicized result indicates analyte reported to the method detection limit.

Bold Bolded result indicates positively identified compound.

- Not analyzed.

D Sample dilution required for analysis; reported values reflect the dilution.

J Data are estimated due to associated quality control data.

T Analyte was positively identified but the reported concentration is estimated; reported concentration is less than the reporting limit, but greater than the method detection limit.

11/18/09

Table 4 Pesticides - Solids.xls

TABLE 5
HERBICIDES SOLID SAMPLE DATA SUMMARY
DEMONSTRATION TESTING AND FULL-SCALE OPERATION OF THE
BIOGENESIS SEDIMENT DECONTAMINATION PROCESS
KEASBEY, NEW JERSEY
(Page 1 of 1)

Field Sample Identification	BAY-1
Sediment Source	Raritan River
Location Identification	PPS
Date Collected	11/23/05
Matrix	Solid
Analyte/Methods (Units)	
Herbicides/SW8151A (µg/kg)	
2,4 DB	<160
2,4,5-T	<40
2,4-D	<160
Dalapon	21 T
Dicamba	<79
Dichloroprop	<160
Dinoseb	<24
MCPA	<16000
MCPP	<16000
Pentachlorophenol	<20
Silvex (2,4,5-TP)	<40

µg/kg micrograms per kilogram.
Bold Bolded result indicates positively identified compound.
T Analyte was positively identified but the reported concentration is estimated; reported concentration is less than the reporting limit, but greater than the method detection limit.

TABLE 6

POLYCHLORINATED BIPHENYLS (AROCLORS) SOLID SAMPLE DATA SUMMARY
DEMONSTRATION TESTING AND FULL-SCALE OPERATION OF THE BIOGENESIS SEDIMENT DECONTAMINATION PROCESS
KEASBEY, NEW JERSEY
 (Page 1 of 1)

Field Sample Identification	PR-A-040107-0905	PR-B-040107-0940	PR-C-040107-1035	PR-D-040107-1055
Sediment Source	Lower Passaic River	Lower Passaic River	Lower Passaic River	Lower Passaic River
Location Identification	MSL	MSL	MSL	MSL
Date Collected	1/4/07	1/4/07	1/4/07	1/4/07
Matrix	Solid	Solid	Solid	Solid
Analyte/Methods (Units)				
Polychlorinated Biphenyls/SW8082 (µg/kg)				
Aroclors				
PCB-1016 (Aroclor 1016)	<100 D	<100 D	<110 D	<110 D
PCB-1221 (Aroclor 1221)	<100 D	<100 D	<110 D	<110 D
PCB-1232 (Aroclor 1232)	<100 D	<100 D	<110 D	<110 D
PCB-1242 (Aroclor 1242)	<100 D	<100 D	<110 D	<110 D
PCB-1248 (Aroclor 1248)	270 D	310 D	240 D	290 D
PCB-1254 (Aroclor 1254)	<100 D	<100 D	<110 D	<110 D
PCB-1260 (Aroclor 1260)	150 D	160 D	130 D	150 D
PCB Aroclors Total	420	470	370	440

µg/kg micrograms per kilogram.

Bold Bolded result indicates positively identified compound.

D Sample dilution required for analysis; reported values reflect the dilution.

TABLE 7

POLYCHLORINATED BIPHENYLS (CONGENERS) SOLID SAMPLE DATA SUMMARY
DEMONSTRATION TESTING AND FULL-SCALE OPERATION OF THE BIOGENESIS SEDIMENT DECONTAMINATION PROCESS
KEASBEY, NEW JERSEY
 (Page 1 of 78)

Field Sample Identification	BAY-1	RS-211205-1000	TS-211205-1715	WS1-211205-1800	TS-291205-1100	WS-291205-1110
Sediment Source	Raritan River	Raritan River	Raritan River	Raritan River	Raritan River	Raritan River
Location Identification	PPS	RS	TS	WS	TS	WS
Date Collected	11/23/05	12/21/05	12/21/05	12/21/05	12/29/05	12/29/05
Matrix	Solid	Solid	Solid	Solid	Solid	Solid
Analyte/Methods (Units)						
Polychlorinated Biphenyls/SW8082 (µg/kg)						
Individual Congeners						
2-Chlorobiphenyl	1.1 T	6.4 TDJ	6.3 TDJ	<27 D	4.7 TDJ	<27 D
4-Chlorobiphenyl	<3.4	-	-	-	-	-
2,3-Dichlorobiphenyl	1.3	<2.3 D	<1.2 D	<2.7 D	<1.2 D	<2.7 D
2,4'-Dichlorobiphenyl	<0.34	-	-	-	-	-
4,4'-Dichlorobiphenyl	<3.4	-	-	-	-	-
2,2',5-Trichlorobiphenyl	0.94	8.8 DJ	<1.2 D	6.3 DJ	5.7 DJ	8.3 DJ
2,4,4'-Trichlorobiphenyl	<0.34	-	-	-	-	-
2,4,5-Trichlorobiphenyl	-	8.3 DJ	4.6 DJ	<2.7 D	4.5 DJ	<2.7 D
2,4',5-Trichlorobiphenyl	<0.34	-	-	-	-	-
3,4,4'-Trichlorobiphenyl	0.43	-	-	-	-	-
2,2',3,5'-Tetrachlorobiphenyl	0.54	-	-	-	-	-
2,2',4,5'-Tetrachlorobiphenyl	0.46	-	-	-	-	-
2,2',5,5'-Tetrachlorobiphenyl	0.86	14 D	7.6 DJ	8.8 D	7.9 D	12 D
2,3',4,4'-Tetrachlorobiphenyl	0.48	14 D	7.7 DJ	8.6 D	8.5 D	12 D
2,3',4',5-Tetrachlorobiphenyl	0.44	-	-	-	-	-
2,4,4',5-Tetrachlorobiphenyl	0.3 T	-	-	-	-	-
3,3',4,4'-Tetrachlorobiphenyl	0.18 T	-	-	-	-	-
3,4,4',5-Tetrachlorobiphenyl	<0.34	-	-	-	-	-
2,2',3,4',5-Pentachlorobiphenyl	<0.34	-	-	-	-	-
2,2',3,4,5'-Pentachlorobiphenyl	0.22 T	4.2 DJ	2.2 DJ	2.5 TDJ	2.4 DJ	3.5 DJ
2,2',4,4',5-Pentachlorobiphenyl	0.46	-	-	-	-	-
2,2',4,5,5'-Pentachlorobiphenyl	0.7	9 D	4.8 DJ	5.5 D	4.8 D	7.7 D
2,3,3',4,4'-Pentachlorobiphenyl	0.24 T	-	-	-	-	-
2,3,3',4',6-Pentachlorobiphenyl	0.89	11 D	5.1 D	5.7 D	5.3 D	8.5 D
2,3',3,5,6-Pentachlorobiphenyl	<0.34	-	-	-	-	-
2,3,4,4',5-Pentachlorobiphenyl	0.083 T	-	-	-	-	-

TABLE 7

POLYCHLORINATED BIPHENYLS (CONGENERS) SOLID SAMPLE DATA SUMMARY
DEMONSTRATION TESTING AND FULL-SCALE OPERATION OF THE BIOGENESIS SEDIMENT DECONTAMINATION PROCESS
KEASBEY, NEW JERSEY
 (Page 2 of 78)

Field Sample Identification	BAY-1	RS-211205-1000	TS-211205-1715	WS1-211205-1800	TS-291205-1100	WS-291205-1110
Sediment Source	Raritan River	Raritan River	Raritan River	Raritan River	Raritan River	Raritan River
Location Identification	PPS	RS	TS	WS	TS	WS
Date Collected	11/23/05	12/21/05	12/21/05	12/21/05	12/29/05	12/29/05
Matrix	Solid	Solid	Solid	Solid	Solid	Solid
Analyte/Methods (Units)						
Polychlorinated Biphenyls/SW8082 (µg/kg)						
Individual Congeners (continued)						
2',3,4,4',5-Pentachlorobiphenyl	<0.34	-	-	-	-	-
2,3',4,4',5-Pentachlorobiphenyl	<0.34	-	-	-	-	-
2,3,4,4',6-Pentachlorobiphenyl	<0.34	-	-	-	-	-
2,3',4,4',6-Pentachlorobiphenyl	<0.34	-	-	-	-	-
3,3',4,4',5-Pentachlorobiphenyl	<0.34	-	-	-	-	-
2,2',3,3',4,4'-Hexachlorobiphenyl	0.3 T	-	-	-	-	-
2,2',3,4,4',5-Hexachlorobiphenyl	0.48	-	-	-	-	-
2,2',3,4,5,5'-Hexachlorobiphenyl	0.078 T	1.1 TD	0.58 TD	<2.7 D	0.56 TD	0.63 TD
2,2',3,4',5',6-Hexachlorobiphenyl	0.54	-	-	-	-	-
2,2',3,5,5',6-Hexachlorobiphenyl	<0.34	<2.3 D	<1.2 D	<2.7 D	<1.2 D	<2.7 D
2,2',4,4',5,5'-Hexachlorobiphenyl	<0.34	4.7 D	2.5 D	2.7 D	2.7 D	3.9 D
2,3,3',4,4',5-Hexachlorobiphenyl	<0.34	-	-	-	-	-
2,3,3',4,4',5'-Hexachlorobiphenyl	<0.34	-	-	-	-	-
2,3,3',4,4',6-Hexachlorobiphenyl	<0.34	-	-	-	-	-
2,3',4,4',5,5'-Hexachlorobiphenyl	0.11 T	-	-	-	-	-
2,3',4,4',5',6-Hexachlorobiphenyl	<0.34	-	-	-	-	-
3,3',4,4',5,5'-Hexachlorobiphenyl	<0.34	-	-	-	-	-
2,2',3,3',4,4',5-Heptachlorobiphenyl	0.13 T	1.1 TD	0.63 TD	<2.7 D	0.5 TD	0.76 TDJ
2,2',3,3',4,5',6'-Heptachlorobiphenyl	0.068 T	-	-	-	-	-
2,2',3,4,4',5,5'-Heptachlorobiphenyl	0.2 T	2.4 D	<1.2 D	1.4 TD	1.5 D	1.9 TD
2,2',3,4,4',5',6-Heptachlorobiphenyl	<0.34	-	-	-	-	-
2,2',3,4,4',6,6'-Heptachlorobiphenyl	<0.34	-	-	-	-	-
2,2',3,4',5,5',6-Heptachlorobiphenyl	0.15 T	1.1 TD	0.56 TD	0.7 TD	0.85 TD	0.93 TD
2,3,3',4,4',5,5'-Heptachlorobiphenyl	<0.34	-	-	-	-	-
2,2',3,3',4,4',5,5'-Octachlorobiphenyl	0.092 T	-	-	-	-	-
2,2',3,3',4,4',5,6-Octachlorobiphenyl	<0.34	-	-	-	-	-

TABLE 7

POLYCHLORINATED BIPHENYLS (CONGENERS) SOLID SAMPLE DATA SUMMARY
DEMONSTRATION TESTING AND FULL-SCALE OPERATION OF THE BIOGENESIS SEDIMENT DECONTAMINATION PROCESS
KEASBEY, NEW JERSEY
 (Page 3 of 78)

Field Sample Identification	BAY-1	RS-211205-1000	TS-211205-1715	WS1-211205-1800	TS-291205-1100	WS-291205-1110
Sediment Source	Raritan River	Raritan River	Raritan River	Raritan River	Raritan River	Raritan River
Location Identification	PPS	RS	TS	WS	TS	WS
Date Collected	11/23/05	12/21/05	12/21/05	12/21/05	12/29/05	12/29/05
Matrix	Solid	Solid	Solid	Solid	Solid	Solid
Analyte/Methods (Units)						
Polychlorinated Biphenyls/SW8082 (µg/kg)						
Individual Congeners (continued)						
2,2',3,3',4,5,5',6'-Octachlorobiphenyl	<0.34	-	-	-	-	-
2,2,3,3,4,5,6,6-Octachlorobiphenyl	<0.34	-	-	-	-	-
2,2',3,3',5,5',6,6'-Octachlorobiphenyl	<0.34	-	-	-	-	-
2,2',3,3',4,4',5,5',6-Nonachlorobiphenyl	<0.34	<2.3 D	<1.2 D	<2.7 D	0.27 TD	<2.7 D
2,2',3,3',4,4',5,6,6'-Nonachlorobiphenyl	<0.34	-	-	-	-	-

µg/kg micrograms per kilogram.

Bold Bolded result indicates positively identified compound.

- Not analyzed.

B Analyte detected in an associated blank.

D Sample dilution required for analysis; reported values reflect the dilution.

J Data are estimated due to associated quality control data.

T Analyte was positively identified but the reported concentration is estimated; reported concentration is less than the reporting limit, but greater than the method detection limit.

TABLE 7

POLYCHLORINATED BIPHENYLS (CONGENERS) SOLID SAMPLE DATA SUMMARY
DEMONSTRATION TESTING AND FULL-SCALE OPERATION OF THE BIOGENESIS SEDIMENT DECONTAMINATION PROCESS
KEASBEY, NEW JERSEY
 (Page 4 of 78)

Field Sample Identification	RS-030106-1600	TS-030106-1645	WS1-030106-1615	WS2-030106-1630	RS-040106-1300	TS-040106-1100
Sediment Source	Raritan River	Raritan River	Raritan River	Raritan River	Raritan River	Raritan River
Location Identification	RS	TS	WS1	WS2	RS	TS
Date Collected	1/3/06	1/3/06	1/3/06	1/3/06	1/4/06	1/4/06
Matrix	Solid	Solid	Solid	Solid	Solid	Solid
Analyte/Methods (Units)						
Polychlorinated Biphenyls/SW8082 (µg/kg)						
Individual Congeners						
2-Chlorobiphenyl	3.9 TDJ	15 TDJ	5.5 TDJ	3.4 TJ	4.1 TJ	<12 D
4-Chlorobiphenyl	-	-	-	-	-	-
2,3-Dichlorobiphenyl	1.7 DJ	3.4 DJ	<1.3 D	0.67 J	1.4 J	1.4 DJ
2,4'-Dichlorobiphenyl	-	-	-	-	-	-
4,4'-Dichlorobiphenyl	-	-	-	-	-	-
2,2',5-Trichlorobiphenyl	4.6 DJ	5.1 DJ	8.7 DJ	6.3	4.7 J	4.3 DJ
2,4,4'-Trichlorobiphenyl	-	-	-	-	-	-
2,4,5-Trichlorobiphenyl	4.9 DJ	5.5 DJ	7.9 DJ	4 J	5.3 J	4.6 DJ
2,4',5-Trichlorobiphenyl	-	-	-	-	-	-
3,4,4'-Trichlorobiphenyl	-	-	-	-	-	-
2,2',3,5'-Tetrachlorobiphenyl	-	-	-	-	-	-
2,2',4,5'-Tetrachlorobiphenyl	-	-	-	-	-	-
2,2',5,5'-Tetrachlorobiphenyl	9.1 D	11 D	16 D	8	8.5	7.7 D
2,3',4,4'-Tetrachlorobiphenyl	8.3 D	9.5 D	14 D	6.9	8.4	8.2 D
2,3',4',5-Tetrachlorobiphenyl	-	-	-	-	-	-
2,4,4',5-Tetrachlorobiphenyl	-	-	-	-	-	-
3,3',4,4'-Tetrachlorobiphenyl	-	-	-	-	-	-
3,4,4',5-Tetrachlorobiphenyl	-	-	-	-	-	-
2,2',3,4',5-Pentachlorobiphenyl	-	-	-	-	-	-
2,2',3,4,5'-Pentachlorobiphenyl	2.4 DJ	2 TDJ	3 DJ	1.4 J	2 J	1.8 DJ
2,2',4,4',5-Pentachlorobiphenyl	-	-	-	-	-	-
2,2',4,5,5'-Pentachlorobiphenyl	4.7 DJ	3.6 DJ	4.6 DJ	2.1 J	3.6	2.8 DJ
2,3,3',4,4'-Pentachlorobiphenyl	-	-	-	-	-	-
2,3,3',4',6-Pentachlorobiphenyl	6.2 D	6.3 D	8.9 D	4.4	4.8	5.2 D
2,3',3,5,6-Pentachlorobiphenyl	-	-	-	-	-	-
2,3,4,4',5-Pentachlorobiphenyl	-	-	-	-	-	-

TABLE 7

POLYCHLORINATED BIPHENYLS (CONGENERS) SOLID SAMPLE DATA SUMMARY
DEMONSTRATION TESTING AND FULL-SCALE OPERATION OF THE BIOGENESIS SEDIMENT DECONTAMINATION PROCESS
KEASBEY, NEW JERSEY
 (Page 5 of 78)

Field Sample Identification	RS-030106-1600	TS-030106-1645	WS1-030106-1615	WS2-030106-1630	RS-040106-1300	TS-040106-1100
Sediment Source	Raritan River	Raritan River	Raritan River	Raritan River	Raritan River	Raritan River
Location Identification	RS	TS	WS1	WS2	RS	TS
Date Collected	1/3/06	1/3/06	1/3/06	1/3/06	1/4/06	1/4/06
Matrix	Solid	Solid	Solid	Solid	Solid	Solid
Analyte/Methods (Units)						
Polychlorinated Biphenyls/SW8082 (µg/kg)						
Individual Congeners (continued)						
2',3,4,4',5-Pentachlorobiphenyl	-	-	-	-	-	-
2,3',4,4',5-Pentachlorobiphenyl	-	-	-	-	-	-
2,3,4,4',6-Pentachlorobiphenyl	-	-	-	-	-	-
2,3',4,4',6-Pentachlorobiphenyl	-	-	-	-	-	-
3,3',4,4',5-Pentachlorobiphenyl	-	-	-	-	-	-
2,2',3,3',4,4'-Hexachlorobiphenyl	-	-	-	-	-	-
2,2',3,4,4',5-Hexachlorobiphenyl	-	-	-	-	-	-
2,2',3,4,5,5'-Hexachlorobiphenyl	0.63 TDJ	0.88 TDJ	0.75 TDJ	0.35 TJ	0.4 TJ	0.6 TDJ
2,2',3,4',5',6-Hexachlorobiphenyl	-	-	-	-	-	-
2,2',3,5,5',6-Hexachlorobiphenyl	<0.93 D	<2.4 D	<1.3 D	<0.49	<0.77	<1.2 D
2,2',4,4',5,5'-Hexachlorobiphenyl	2.3 D	3.7 D	3.3 D	1.6	1.8	2.5 D
2,3,3',4,4',5-Hexachlorobiphenyl	-	-	-	-	-	-
2,3,3',4,4',5'-Hexachlorobiphenyl	-	-	-	-	-	-
2,3,3',4,4',6-Hexachlorobiphenyl	-	-	-	-	-	-
2,3',4,4',5,5'-Hexachlorobiphenyl	-	-	-	-	-	-
2,3',4,4',5',6-Hexachlorobiphenyl	-	-	-	-	-	-
3,3',4,4',5,5'-Hexachlorobiphenyl	-	-	-	-	-	-
2,2',3,3',4,4',5-Heptachlorobiphenyl	0.67 TDJ	0.78 TD	0.76 TDJ	0.53 J	0.54 T	0.66 TD
2,2',3,3',4,5',6'-Heptachlorobiphenyl	-	-	-	-	-	-
2,2',3,4,4',5,5'-Heptachlorobiphenyl	0.87 TDJ	1.1 TDJ	1.3 D	0.63	0.64 TJ	0.85 TDJ
2,2',3,4,4',5',6-Heptachlorobiphenyl	-	-	-	-	-	-
2,2',3,4,4',6,6'-Heptachlorobiphenyl	-	-	-	-	-	-
2,2',3,4',5,5',6-Heptachlorobiphenyl	0.76 TD	0.77 TD	1.1 TD	0.53	0.56 T	0.68 TD
2,3,3',4,4',5,5'-Heptachlorobiphenyl	-	-	-	-	-	-
2,2',3,3',4,4',5,5'-Octachlorobiphenyl	-	-	-	-	-	-
2,2',3,3',4,4',5,6-Octachlorobiphenyl	-	-	-	-	-	-

TABLE 7

POLYCHLORINATED BIPHENYLS (CONGENERS) SOLID SAMPLE DATA SUMMARY
DEMONSTRATION TESTING AND FULL-SCALE OPERATION OF THE BIOGENESIS SEDIMENT DECONTAMINATION PROCESS
KEASBEY, NEW JERSEY
 (Page 6 of 78)

Field Sample Identification	RS-030106-1600	TS-030106-1645	WS1-030106-1615	WS2-030106-1630	RS-040106-1300	TS-040106-1100
Sediment Source	Raritan River	Raritan River	Raritan River	Raritan River	Raritan River	Raritan River
Location Identification	RS	TS	WS1	WS2	RS	TS
Date Collected	1/3/06	1/3/06	1/3/06	1/3/06	1/4/06	1/4/06
Matrix	Solid	Solid	Solid	Solid	Solid	Solid
Analyte/Methods (Units)						
Polychlorinated Biphenyls/SW8082 (µg/kg)						
Individual Congeners (continued)						
2,2',3,3',4,5,5',6'-Octachlorobiphenyl	-	-	-	-	-	-
2,2,3,3,4,5,6,6-Octachlorobiphenyl	-	-	-	-	-	-
2,2',3,3',5,5',6,6'-Octachlorobiphenyl	-	-	-	-	-	-
2,2',3,3',4,4',5,5',6-Nonachlorobiphenyl	0.29 TDJ	<2.4 D	0.47 TDJ	0.2 T	<0.77	<1.2 D
2,2',3,3',4,4',5,6,6'-Nonachlorobiphenyl	-	-	-	-	-	-

µg/kg micrograms per kilogram.

Bold Bolded result indicates positively identified compound.

- Not analyzed.

B Analyte detected in an associated blank.

D Sample dilution required for analysis; reported values reflect the dilution.

J Data are estimated due to associated quality control data.

T Analyte was positively identified but the reported concentration is estimated; reported concentration is less than the reporting limit, but greater than the method detection limit.

TABLE 7

POLYCHLORINATED BIPHENYLS (CONGENERS) SOLID SAMPLE DATA SUMMARY
DEMONSTRATION TESTING AND FULL-SCALE OPERATION OF THE BIOGENESIS SEDIMENT DECONTAMINATION PROCESS
KEASBEY, NEW JERSEY
 (Page 7 of 78)

Field Sample Identification	WS-040106-1400	RS-050106-1500	TS-050106-1505	WS-050106-1510	RS-060106-1531	TS-060106-1532
Sediment Source	Raritan River	Raritan River	Raritan River	Raritan River	Raritan River	Raritan River
Location Identification	WS	RS	TS	WS	RS	TS
Date Collected	1/4/06	1/5/06	1/5/06	1/5/06	1/6/06	1/6/06
Matrix	Solid	Solid	Solid	Solid	Solid	Solid
Analyte/Methods (Units)						
Polychlorinated Biphenyls/SW8082 (µg/kg)						
Individual Congeners						
2-Chlorobiphenyl	4 TDJ	3.1 TJ	5.3 TDJ	<4.7	<21	2.8 TDJ
4-Chlorobiphenyl	-	-	-	-	-	-
2,3-Dichlorobiphenyl	0.73 TDJ	1.1 J	1.6 DJ	0.39 TJ	1.6 TJ	1.2 DJ
2,4'-Dichlorobiphenyl	-	-	-	-	-	-
4,4'-Dichlorobiphenyl	-	-	-	-	-	-
2,2',5-Trichlorobiphenyl	6.9 DJ	4.1 J	4.5 DJ	3.1 J	3.7 J	3.7 DJ
2,4,4'-Trichlorobiphenyl	-	-	-	-	-	-
2,4,5-Trichlorobiphenyl	6.2 DJ	4.5 J	4.8 DJ	2.9 J	3.6 J	4.2 DJ
2,4',5-Trichlorobiphenyl	-	-	-	-	-	-
3,4,4'-Trichlorobiphenyl	-	-	-	-	-	-
2,2',3,5'-Tetrachlorobiphenyl	-	-	-	-	-	-
2,2',4,5'-Tetrachlorobiphenyl	-	-	-	-	-	-
2,2',5,5'-Tetrachlorobiphenyl	12 D	8.2	7.9 D	5.4	6.1	7 D
2,3',4,4'-Tetrachlorobiphenyl	10 D	7.4	8.3 D	4.8	8.4	6.9 D
2,3',4',5-Tetrachlorobiphenyl	-	-	-	-	-	-
2,4,4',5-Tetrachlorobiphenyl	-	-	-	-	-	-
3,3',4,4'-Tetrachlorobiphenyl	-	-	-	-	-	-
3,4,4',5-Tetrachlorobiphenyl	-	-	-	-	-	-
2,2',3,4',5-Pentachlorobiphenyl	-	-	-	-	-	-
2,2',3,4,5'-Pentachlorobiphenyl	2.2 DJ	1.6 J	1.8 DJ	1.1 J	1.5 TJ	1.6 DJ
2,2',4,4',5-Pentachlorobiphenyl	-	-	-	-	-	-
2,2',4,5,5'-Pentachlorobiphenyl	3.4 DJ	3.6	2.8 DJ	2.3	3.6	3.3 D
2,3,3',4,4'-Pentachlorobiphenyl	-	-	-	-	-	-
2,3,3',4',6-Pentachlorobiphenyl	6.7 D	5	5.4 D	3	4.3	4.7 D
2,3',3,5,6-Pentachlorobiphenyl	-	-	-	-	-	-
2,3,4,4',5-Pentachlorobiphenyl	-	-	-	-	-	-

TABLE 7

POLYCHLORINATED BIPHENYLS (CONGENERS) SOLID SAMPLE DATA SUMMARY
DEMONSTRATION TESTING AND FULL-SCALE OPERATION OF THE BIOGENESIS SEDIMENT DECONTAMINATION PROCESS
KEASBEY, NEW JERSEY
 (Page 8 of 78)

Field Sample Identification	WS-040106-1400	RS-050106-1500	TS-050106-1505	WS-050106-1510	RS-060106-1531	TS-060106-1532
Sediment Source	Raritan River	Raritan River	Raritan River	Raritan River	Raritan River	Raritan River
Location Identification	WS	RS	TS	WS	RS	TS
Date Collected	1/4/06	1/5/06	1/5/06	1/5/06	1/6/06	1/6/06
Matrix	Solid	Solid	Solid	Solid	Solid	Solid
Analyte/Methods (Units)						
Polychlorinated Biphenyls/SW8082 (µg/kg)						
Individual Congeners (continued)						
2',3,4,4',5-Pentachlorobiphenyl	-	-	-	-	-	-
2,3',4,4',5-Pentachlorobiphenyl	-	-	-	-	-	-
2,3,4,4',6-Pentachlorobiphenyl	-	-	-	-	-	-
2,3',4,4',6-Pentachlorobiphenyl	-	-	-	-	-	-
3,3',4,4',5-Pentachlorobiphenyl	-	-	-	-	-	-
2,2',3,3',4,4'-Hexachlorobiphenyl	-	-	-	-	-	-
2,2',3,4,4',5-Hexachlorobiphenyl	-	-	-	-	-	-
2,2',3,4,5,5'-Hexachlorobiphenyl	0.53 TDJ	0.45 TJ	0.49 TDJ	0.26 TJ	<2.1	0.45 TDJ
2,2',3,4',5',6-Hexachlorobiphenyl	-	-	-	-	-	-
2,2',3,5,5',6-Hexachlorobiphenyl	<1.1 D	<0.52	<1.3 D	<0.47	<2.1	<0.54 D
2,2',4,4',5,5'-Hexachlorobiphenyl	2.4 D	1.9	2.2 D	1.2	1.5 TJ	1.9 D
2,3,3',4,4',5-Hexachlorobiphenyl	-	-	-	-	-	-
2,3,3',4,4',5'-Hexachlorobiphenyl	-	-	-	-	-	-
2,3,3',4,4',6-Hexachlorobiphenyl	-	-	-	-	-	-
2,3',4,4',5,5'-Hexachlorobiphenyl	-	-	-	-	-	-
2,3',4,4',5',6-Hexachlorobiphenyl	-	-	-	-	-	-
3,3',4,4',5,5'-Hexachlorobiphenyl	-	-	-	-	-	-
2,2',3,3',4,4',5-Heptachlorobiphenyl	0.59 TDJ	0.67	0.59 TD	0.35 T	<2.1	0.42 TD
2,2',3,3',4,5',6'-Heptachlorobiphenyl	-	-	-	-	-	-
2,2',3,4,4',5,5'-Heptachlorobiphenyl	0.95 TDJ	0.86 J	0.85 TDJ	0.42 TJ	0.77 T	0.71 DJ
2,2',3,4,4',5',6-Heptachlorobiphenyl	-	-	-	-	-	-
2,2',3,4,4',6,6'-Heptachlorobiphenyl	-	-	-	-	-	-
2,2',3,4',5,5',6-Heptachlorobiphenyl	0.83 TD	0.73	0.65 TD	0.36 T	0.47 T	0.56 D
2,3,3',4,4',5,5'-Heptachlorobiphenyl	-	-	-	-	-	-
2,2',3,3',4,4',5,5'-Octachlorobiphenyl	-	-	-	-	-	-
2,2',3,3',4,4',5,6-Octachlorobiphenyl	-	-	-	-	-	-

TABLE 7

POLYCHLORINATED BIPHENYLS (CONGENERS) SOLID SAMPLE DATA SUMMARY
DEMONSTRATION TESTING AND FULL-SCALE OPERATION OF THE BIOGENESIS SEDIMENT DECONTAMINATION PROCESS
KEASBEY, NEW JERSEY
 (Page 9 of 78)

Field Sample Identification	WS-040106-1400	RS-050106-1500	TS-050106-1505	WS-050106-1510	RS-060106-1531	TS-060106-1532
Sediment Source	Raritan River	Raritan River	Raritan River	Raritan River	Raritan River	Raritan River
Location Identification	WS	RS	TS	WS	RS	TS
Date Collected	1/4/06	1/5/06	1/5/06	1/5/06	1/6/06	1/6/06
Matrix	Solid	Solid	Solid	Solid	Solid	Solid
Analyte/Methods (Units)						
Polychlorinated Biphenyls/SW8082 (µg/kg)						
Individual Congeners (continued)						
2,2',3,3',4,5,5',6'-Octachlorobiphenyl	-	-	-	-	-	-
2,2,3,3,4,5,6,6-Octachlorobiphenyl	-	-	-	-	-	-
2,2',3,3',5,5',6,6'-Octachlorobiphenyl	-	-	-	-	-	-
2,2',3,3',4,4',5,5',6-Nonachlorobiphenyl	0.32 TD	0.2 T	<1.3 D	0.17 T	<2.1	0.24 TD
2,2',3,3',4,4',5,6,6'-Nonachlorobiphenyl	-	-	-	-	-	-

µg/kg micrograms per kilogram.

Bold Bolded result indicates positively identified compound.

- Not analyzed.

B Analyte detected in an associated blank.

D Sample dilution required for analysis; reported values reflect the dilution.

J Data are estimated due to associated quality control data.

T Analyte was positively identified but the reported concentration is estimated; reported concentration is less than the reporting limit, but greater than the method detection limit.

TABLE 7

POLYCHLORINATED BIPHENYLS (CONGENERS) SOLID SAMPLE DATA SUMMARY
DEMONSTRATION TESTING AND FULL-SCALE OPERATION OF THE BIOGENESIS SEDIMENT DECONTAMINATION PROCESS
KEASBEY, NEW JERSEY
 (Page 10 of 78)

Field Sample Identification	WS-060106-1533	RS-090106-1500	TS-090106-1501	WS-090106-1502	RS-100106-1600	TS-100106-1601
Sediment Source	Raritan River	Raritan River	Raritan River	Raritan River	Raritan River	Raritan River
Location Identification	WS	RS	TS	WS	RS	TS
Date Collected	1/6/06	1/9/06	1/9/06	1/9/06	1/10/06	1/10/06
Matrix	Solid	Solid	Solid	Solid	Solid	Solid
Analyte/Methods (Units)						
Polychlorinated Biphenyls/SW8082 (µg/kg)						
Individual Congeners						
2-Chlorobiphenyl	3.7 TDJ	4 TJ	7.6 TDJ	3.5 TDJ	9.7 TDJ	150 TDJ
4-Chlorobiphenyl	-	-	-	-	-	-
2,3-Dichlorobiphenyl	0.7 TDJ	1.4 J	3.6 DJ	0.51 TDJ	3.2 DJ	77 DJ
2,4'-Dichlorobiphenyl	-	-	-	-	-	-
4,4'-Dichlorobiphenyl	-	-	-	-	-	-
2,2',5-Trichlorobiphenyl	6.7 DJ	4.3 J	4.3 DJ	5.3 DJ	9.6 DJ	38 DJ
2,4,4'-Trichlorobiphenyl	-	-	-	-	-	-
2,4,5-Trichlorobiphenyl	6.3 DJ	4.9 J	4.4 DJ	5.2 DJ	8.8 DJ	29 TD
2,4',5-Trichlorobiphenyl	-	4.9	4.4 D	5.2 D	8.8 D	29 TD
3,4,4'-Trichlorobiphenyl	-	-	-	-	-	-
2,2',3,5'-Tetrachlorobiphenyl	-	-	-	-	-	-
2,2',4,5'-Tetrachlorobiphenyl	-	-	-	-	-	-
2,2',5,5'-Tetrachlorobiphenyl	12 D	8.8	8 D	9 D	17 D	24 TDJ
2,3',4,4'-Tetrachlorobiphenyl	10 D	8	8.3 D	8 D	16 D	40 DJ
2,3',4',5-Tetrachlorobiphenyl	-	-	-	-	-	-
2,4,4',5-Tetrachlorobiphenyl	-	-	-	-	-	-
3,3',4,4'-Tetrachlorobiphenyl	-	-	-	-	-	-
3,4,4',5-Tetrachlorobiphenyl	-	-	-	-	-	-
2,2',3,4',5-Pentachlorobiphenyl	-	-	-	-	-	-
2,2',3,4,5'-Pentachlorobiphenyl	2.4 DJ	1.7 J	1.5 TDJ	1.9 DJ	3.2 DJ	9.7 TDJ
2,2',4,4',5-Pentachlorobiphenyl	-	-	-	-	-	-
2,2',4,5,5'-Pentachlorobiphenyl	5.2 D	3.8	2.5 TDJ	4 D	5.3 DJ	14 TDJ
2,3,3',4,4'-Pentachlorobiphenyl	-	-	-	-	-	-
2,3,3',4',6-Pentachlorobiphenyl	6.8 D	5.1	5 D	5.2 D	11 D	34 D
2,3',3,5,6-Pentachlorobiphenyl	-	-	-	-	-	-
2,3,4,4',5-Pentachlorobiphenyl	-	-	-	-	-	-

TABLE 7

POLYCHLORINATED BIPHENYLS (CONGENERS) SOLID SAMPLE DATA SUMMARY
DEMONSTRATION TESTING AND FULL-SCALE OPERATION OF THE BIOGENESIS SEDIMENT DECONTAMINATION PROCESS
KEASBEY, NEW JERSEY
 (Page 11 of 78)

Field Sample Identification	WS-060106-1533	RS-090106-1500	TS-090106-1501	WS-090106-1502	RS-100106-1600	TS-100106-1601
Sediment Source	Raritan River	Raritan River	Raritan River	Raritan River	Raritan River	Raritan River
Location Identification	WS	RS	TS	WS	RS	TS
Date Collected	1/6/06	1/9/06	1/9/06	1/9/06	1/10/06	1/10/06
Matrix	Solid	Solid	Solid	Solid	Solid	Solid
Analyte/Methods (Units)						
Polychlorinated Biphenyls/SW8082 (µg/kg)						
Individual Congeners (continued)						
2',3,4,4',5-Pentachlorobiphenyl	-	-	-	-	-	-
2,3',4,4',5-Pentachlorobiphenyl	-	-	-	-	-	-
2,3,4,4',6-Pentachlorobiphenyl	-	-	-	-	-	-
2,3',4,4',6-Pentachlorobiphenyl	-	-	-	-	-	-
3,3',4,4',5-Pentachlorobiphenyl	-	-	-	-	-	-
2,2',3,3',4,4'-Hexachlorobiphenyl	-	-	-	-	-	-
2,2',3,4,4',5-Hexachlorobiphenyl	-	-	-	-	-	-
2,2',3,4,5,5'-Hexachlorobiphenyl	0.68 TDJ	0.44 TJ	<2.6 D	0.44 TDJ	0.94 TDJ	5.5 TDJ
2,2',3,4',5',6-Hexachlorobiphenyl	-	-	-	-	-	-
2,2',3,5,5',6-Hexachlorobiphenyl	<0.96 D	<0.67	<2.6 D	<0.91 D	<1.7 D	<32 D
2,2',4,4',5,5'-Hexachlorobiphenyl	2.6 D	2.3	2.4 TD	1.9 D	3.8 D	13 TDJ
2,3,3',4,4',5-Hexachlorobiphenyl	-	-	-	-	-	-
2,3,3',4,4',5'-Hexachlorobiphenyl	-	-	-	-	-	-
2,3,3',4,4',6-Hexachlorobiphenyl	-	-	-	-	-	-
2,3',4,4',5,5'-Hexachlorobiphenyl	-	-	-	-	-	-
2,3',4,4',5',6-Hexachlorobiphenyl	-	-	-	-	-	-
3,3',4,4',5,5'-Hexachlorobiphenyl	-	-	-	-	-	-
2,2',3,3',4,4',5-Heptachlorobiphenyl	0.81 TD	0.55 T	<2.6 D	0.58 TD	1.2 TD	<32 D
2,2',3,3',4,5',6'-Heptachlorobiphenyl	-	-	-	-	-	-
2,2',3,4,4',5,5'-Heptachlorobiphenyl	1 DJ	0.72 J	1.1 TD	0.69 TDJ	2.1 D	<32 D
2,2',3,4,4',5',6-Heptachlorobiphenyl	-	-	-	-	-	-
2,2',3,4,4',6,6'-Heptachlorobiphenyl	-	-	-	-	-	-
2,2',3,4',5,5',6-Heptachlorobiphenyl	0.88 TD	0.7	<2.6 D	0.61 TD	1.2 TD	<32 D
2,3,3',4,4',5,5'-Heptachlorobiphenyl	-	-	-	-	-	-
2,2',3,3',4,4',5,5'-Octachlorobiphenyl	-	-	-	-	-	-
2,2',3,3',4,4',5,6-Octachlorobiphenyl	-	-	-	-	-	-

TABLE 7

POLYCHLORINATED BIPHENYLS (CONGENERS) SOLID SAMPLE DATA SUMMARY
DEMONSTRATION TESTING AND FULL-SCALE OPERATION OF THE BIOGENESIS SEDIMENT DECONTAMINATION PROCESS
KEASBEY, NEW JERSEY
 (Page 12 of 78)

Field Sample Identification	WS-060106-1533	RS-090106-1500	TS-090106-1501	WS-090106-1502	RS-100106-1600	TS-100106-1601
Sediment Source	Raritan River	Raritan River	Raritan River	Raritan River	Raritan River	Raritan River
Location Identification	WS	RS	TS	WS	RS	TS
Date Collected	1/6/06	1/9/06	1/9/06	1/9/06	1/10/06	1/10/06
Matrix	Solid	Solid	Solid	Solid	Solid	Solid
Analyte/Methods (Units)						
Polychlorinated Biphenyls/SW8082 (µg/kg)						
Individual Congeners (continued)						
2,2',3,3',4,5,5',6'-Octachlorobiphenyl	-	-	-	-	-	-
2,2,3,3,4,5,6,6-Octachlorobiphenyl	-	-	-	-	-	-
2,2',3,3',5,5',6,6'-Octachlorobiphenyl	-	-	-	-	-	-
2,2',3,3',4,4',5,5',6-Nonachlorobiphenyl	0.36 TD	0.28 T	<2.6 D	0.24 TD	0.54 TD	<32 D
2,2',3,3',4,4',5,6,6'-Nonachlorobiphenyl	-	-	-	-	-	-

µg/kg micrograms per kilogram.

Bold Bolded result indicates positively identified compound.

- Not analyzed.

B Analyte detected in an associated blank.

D Sample dilution required for analysis; reported values reflect the dilution.

J Data are estimated due to associated quality control data.

T Analyte was positively identified but the reported concentration is estimated; reported concentration is less than the reporting limit, but greater than the method detection limit.

TABLE 7

POLYCHLORINATED BIPHENYLS (CONGENERS) SOLID SAMPLE DATA SUMMARY
DEMONSTRATION TESTING AND FULL-SCALE OPERATION OF THE BIOGENESIS SEDIMENT DECONTAMINATION PROCESS
KEASBEY, NEW JERSEY
 (Page 13 of 78)

Field Sample Identification	WS-100106-1602	RS-110106-1630	TS-110106-1631	RS-120106-1630	TS-120106-1601	WS-120106-1602
Sediment Source	Raritan River	Raritan River	Raritan River	Raritan River	Raritan River	Raritan River
Location Identification	WS	RS	TS	RS	TS	WS
Date Collected	1/10/06	1/11/06	1/11/06	1/12/06	1/12/06	1/12/06
Matrix	Solid	Solid	Solid	Solid	Solid	Solid
Analyte/Methods (Units)						
Polychlorinated Biphenyls/SW8082 (µg/kg)						
Individual Congeners						
2-Chlorobiphenyl	3.9 TJ	6.8 J	87 DJ	2.9 TJ	13 TDJ	2.8 TJ
4-Chlorobiphenyl	-	-	-	-	-	-
2,3-Dichlorobiphenyl	1.1 J	2.2 J	29 D	0.63 J	4.7 DJ	0.32 TJ
2,4'-Dichlorobiphenyl	-	-	-	-	-	-
4,4'-Dichlorobiphenyl	-	-	-	-	-	-
2,2',5-Trichlorobiphenyl	5.6 J	7.7 J	20 DJ	2.7 J	12 DJ	4.3
2,4,4'-Trichlorobiphenyl	-	-	-	-	-	-
2,4,5-Trichlorobiphenyl	5.2 J	7.8 J	18 DJ	2.7 J	12 DJ	2.7 J
2,4',5-Trichlorobiphenyl	5.2	7.8	18 D	2.7	12 D	2.7
3,4,4'-Trichlorobiphenyl	-	-	-	-	-	-
2,2',3,5'-Tetrachlorobiphenyl	-	-	-	-	-	-
2,2',4,5'-Tetrachlorobiphenyl	-	-	-	-	-	-
2,2',5,5'-Tetrachlorobiphenyl	10 J	16	26 DJ	4.6	20 D	5.0
2,3',4,4'-Tetrachlorobiphenyl	9 J	14	28 D	5.0	20 D	4.5
2,3',4',5-Tetrachlorobiphenyl	-	-	-	-	-	-
2,4,4',5-Tetrachlorobiphenyl	-	-	-	-	-	-
3,3',4,4'-Tetrachlorobiphenyl	-	-	-	-	-	-
3,4,4',5-Tetrachlorobiphenyl	-	-	-	-	-	-
2,2',3,4',5-Pentachlorobiphenyl	-	-	-	-	-	-
2,2',3,4,5'-Pentachlorobiphenyl	1.8 J	3.1 J	4.9 DJ	0.96 J	4.2 DJ	0.98 J
2,2',4,4',5-Pentachlorobiphenyl	-	-	-	-	-	-
2,2',4,5,5'-Pentachlorobiphenyl	2.8 J	4.6 J	9.8 DJ	2.0	7.7 D	1.5 J
2,3,3',4,4'-Pentachlorobiphenyl	-	-	-	-	-	-
2,3,3',4',6-Pentachlorobiphenyl	5.5	9.5	16 D	2.6	13 D	3.0
2,3',3,5,6-Pentachlorobiphenyl	-	-	-	-	-	-
2,3,4,4',5-Pentachlorobiphenyl	-	-	-	-	-	-

TABLE 7

POLYCHLORINATED BIPHENYLS (CONGENERS) SOLID SAMPLE DATA SUMMARY
DEMONSTRATION TESTING AND FULL-SCALE OPERATION OF THE BIOGENESIS SEDIMENT DECONTAMINATION PROCESS
KEASBEY, NEW JERSEY
 (Page 14 of 78)

Field Sample Identification	WS-100106-1602	RS-110106-1630	TS-110106-1631	RS-120106-1630	TS-120106-1601	WS-120106-1602
Sediment Source	Raritan River	Raritan River	Raritan River	Raritan River	Raritan River	Raritan River
Location Identification	WS	RS	TS	RS	TS	WS
Date Collected	1/10/06	1/11/06	1/11/06	1/12/06	1/12/06	1/12/06
Matrix	Solid	Solid	Solid	Solid	Solid	Solid
Analyte/Methods (Units)						
Polychlorinated Biphenyls/SW8082 (µg/kg)						
Individual Congeners (continued)						
2',3,4,4',5-Pentachlorobiphenyl	-	-	-	-	-	-
2,3',4,4',5-Pentachlorobiphenyl	-	-	-	-	-	-
2,3,4,4',6-Pentachlorobiphenyl	-	-	-	-	-	-
2,3',4,4',6-Pentachlorobiphenyl	-	-	-	-	-	-
3,3',4,4',5-Pentachlorobiphenyl	-	-	-	-	-	-
2,2',3,3',4,4'-Hexachlorobiphenyl	-	-	-	-	-	-
2,2',3,4,4',5-Hexachlorobiphenyl	-	-	-	-	-	-
2,2',3,4,5,5'-Hexachlorobiphenyl	0.53 J	0.92 J	2.4 TDJ	0.17 TJ	1 TDJ	0.23 TJ
2,2',3,4',5',6-Hexachlorobiphenyl	-	-	-	-	-	-
2,2',3,5,5',6-Hexachlorobiphenyl	<0.42	<0.48	<3.5 D	<0.61	<2.9 D	<0.53
2,2',4,4',5,5'-Hexachlorobiphenyl	1.9	3.6	9.7 DJ	0.96	6.4 D	1.1
2,3,3',4,4',5-Hexachlorobiphenyl	-	-	-	-	-	-
2,3,3',4,4',5'-Hexachlorobiphenyl	-	-	-	-	-	-
2,3,3',4,4',6-Hexachlorobiphenyl	-	-	-	-	-	-
2,3',4,4',5,5'-Hexachlorobiphenyl	-	-	-	-	-	-
2,3',4,4',5',6-Hexachlorobiphenyl	-	-	-	-	-	-
3,3',4,4',5,5'-Hexachlorobiphenyl	-	-	-	-	-	-
2,2',3,3',4,4',5-Heptachlorobiphenyl	0.53	0.98	2.6 TD	0.27 T	1.1 TD	0.34 T
2,2',3,3',4,5',6'-Heptachlorobiphenyl	-	-	-	-	-	-
2,2',3,4,4',5,5'-Heptachlorobiphenyl	0.73	1.1 J	3.8 DJ	0.36 TJ	2.7 TD	0.41 TJ
2,2',3,4,4',5',6-Heptachlorobiphenyl	-	-	-	-	-	-
2,2',3,4,4',6,6'-Heptachlorobiphenyl	-	-	-	-	-	-
2,2',3,4',5,5',6-Heptachlorobiphenyl	0.58	1.0	1.3 TDJ	0.31 T	1.2 TD	0.37 T
2,3,3',4,4',5,5'-Heptachlorobiphenyl	-	-	-	-	-	-
2,2',3,3',4,4',5,5'-Octachlorobiphenyl	-	-	-	-	-	-
2,2',3,3',4,4',5,6-Octachlorobiphenyl	-	-	-	-	-	-

TABLE 7

POLYCHLORINATED BIPHENYLS (CONGENERS) SOLID SAMPLE DATA SUMMARY
DEMONSTRATION TESTING AND FULL-SCALE OPERATION OF THE BIOGENESIS SEDIMENT DECONTAMINATION PROCESS
KEASBEY, NEW JERSEY
 (Page 15 of 78)

Field Sample Identification	WS-100106-1602	RS-110106-1630	TS-110106-1631	RS-120106-1630	TS-120106-1601	WS-120106-1602
Sediment Source	Raritan River	Raritan River	Raritan River	Raritan River	Raritan River	Raritan River
Location Identification	WS	RS	TS	RS	TS	WS
Date Collected	1/10/06	1/11/06	1/11/06	1/12/06	1/12/06	1/12/06
Matrix	Solid	Solid	Solid	Solid	Solid	Solid
Analyte/Methods (Units)						
Polychlorinated Biphenyls/SW8082 (µg/kg)						
Individual Congeners (continued)						
2,2',3,3',4,5,5',6'-Octachlorobiphenyl	-	-	-	-	-	-
2,2,3,3,4,5,6,6-Octachlorobiphenyl	-	-	-	-	-	-
2,2',3,3',5,5',6,6'-Octachlorobiphenyl	-	-	-	-	-	-
2,2',3,3',4,4',5,5',6-Nonachlorobiphenyl	0.24 T	0.35 T	<3.5 D	0.14 TJ	<2.9 D	0.14 T
2,2',3,3',4,4',5,6,6'-Nonachlorobiphenyl	-	-	-	-	-	-

µg/kg micrograms per kilogram.

Bold Bolded result indicates positively identified compound.

- Not analyzed.

B Analyte detected in an associated blank.

D Sample dilution required for analysis; reported values reflect the dilution.

J Data are estimated due to associated quality control data.

T Analyte was positively identified but the reported concentration is estimated; reported concentration is less than the reporting limit, but greater than the method detection limit.

TABLE 7

POLYCHLORINATED BIPHENYLS (CONGENERS) SOLID SAMPLE DATA SUMMARY
DEMONSTRATION TESTING AND FULL-SCALE OPERATION OF THE BIOGENESIS SEDIMENT DECONTAMINATION PROCESS
KEASBEY, NEW JERSEY
 (Page 16 of 78)

Field Sample Identification	RS-190106-1600	TS-190106-1601	WS-190106-1602	RS-240106-1530	TS-240106-1630	RS-270106-1400
Sediment Source	Lower Passaic River	Lower Passaic River	Lower Passaic River	Lower Passaic River	Lower Passaic River	Lower Passaic River
Location Identification	RS	TS	WS	RS	TS	RS
Date Collected	1/19/06	1/19/06	1/19/06	1/24/06	1/24/06	1/27/06
Matrix	Solid	Solid	Solid	Solid	Solid	Solid
Analyte/Methods (Units)						
Polychlorinated Biphenyls/SW8082 (µg/kg)						
Individual Congeners						
2-Chlorobiphenyl	<91 D	17 TDJ	<65 D	<80 D	<27 D	<54 D
4-Chlorobiphenyl	-	-	-	-	-	-
2,3-Dichlorobiphenyl	8.2 TDJ	13 D	<6.5 D	8.3 DJ	10 D	6.9 D
2,4'-Dichlorobiphenyl	-	-	-	-	-	-
4,4'-Dichlorobiphenyl	-	-	-	-	-	-
2,2',5-Trichlorobiphenyl	85 D	79 D	62 D	68 D	56 D	42 D
2,4,4'-Trichlorobiphenyl	-	-	-	-	-	-
2,4,5-Trichlorobiphenyl	78 D	71 D	54 D	64 D	59 D	40 D
2,4',5-Trichlorobiphenyl	-	-	-	-	-	-
3,4,4'-Trichlorobiphenyl	-	-	-	-	-	-
2,2',3,5'-Tetrachlorobiphenyl	-	-	-	-	-	-
2,2',4,5'-Tetrachlorobiphenyl	-	-	-	-	-	-
2,2',5,5'-Tetrachlorobiphenyl	78 D	74 D	63 D	66 D	58 D	40 D
2,3',4,4'-Tetrachlorobiphenyl	73 D	65 D	57 D	61 D	57 D	41 D
2,3',4',5-Tetrachlorobiphenyl	-	-	-	-	-	-
2,4,4',5-Tetrachlorobiphenyl	-	-	-	-	-	-
3,3',4,4'-Tetrachlorobiphenyl	-	-	-	-	-	-
3,4,4',5-Tetrachlorobiphenyl	-	-	-	-	-	-
2,2',3,4',5-Pentachlorobiphenyl	-	-	-	-	-	-
2,2',3,4,5'-Pentachlorobiphenyl	20 DJ	16 DJ	15 DJ	16 DJ	15 DJ	10 DJ
2,2',4,4',5-Pentachlorobiphenyl	-	-	-	-	-	-
2,2',4,5,5'-Pentachlorobiphenyl	47 D	39 D	34 D	40 D	38 D	27 D
2,3,3',4,4'-Pentachlorobiphenyl	-	-	-	-	-	-
2,3,3',4',6-Pentachlorobiphenyl	59 D	49 D	44 D	49 D	48 D	33 D
2,3',3,5,6-Pentachlorobiphenyl	-	-	-	-	-	-
2,3,4,4',5-Pentachlorobiphenyl	-	-	-	-	-	-

TABLE 7

POLYCHLORINATED BIPHENYLS (CONGENERS) SOLID SAMPLE DATA SUMMARY
DEMONSTRATION TESTING AND FULL-SCALE OPERATION OF THE BIOGENESIS SEDIMENT DECONTAMINATION PROCESS
KEASBEY, NEW JERSEY
 (Page 17 of 78)

Field Sample Identification	RS-190106-1600	TS-190106-1601	WS-190106-1602	RS-240106-1530	TS-240106-1630	RS-270106-1400
Sediment Source	Lower Passaic River	Lower Passaic River	Lower Passaic River	Lower Passaic River	Lower Passaic River	Lower Passaic River
Location Identification	RS	TS	WS	RS	TS	RS
Date Collected	1/19/06	1/19/06	1/19/06	1/24/06	1/24/06	1/27/06
Matrix	Solid	Solid	Solid	Solid	Solid	Solid
Analyte/Methods (Units)						
Polychlorinated Biphenyls/SW8082 (µg/kg)						
Individual Congeners (continued)						
2',3,4,4',5-Pentachlorobiphenyl	-	-	-	-	-	-
2,3',4,4',5-Pentachlorobiphenyl	-	-	-	-	-	-
2,3,4,4',6-Pentachlorobiphenyl	-	-	-	-	-	-
2,3',4,4',6-Pentachlorobiphenyl	-	-	-	-	-	-
3,3',4,4',5-Pentachlorobiphenyl	-	-	-	-	-	-
2,2',3,3',4,4'-Hexachlorobiphenyl	-	-	-	-	-	-
2,2',3,4,4',5-Hexachlorobiphenyl	-	-	-	-	-	-
2,2',3,4,5,5'-Hexachlorobiphenyl	19 D	15 D	9 DJ	15 D	15 D	8.1 D
2,2',3,4',5',6-Hexachlorobiphenyl	-	-	-	-	-	-
2,2',3,5,5',6-Hexachlorobiphenyl	<9.1 D	<3.2 D	<6.5 D	<8.0 D	<2.7 D	<5.4 D
2,2',4,4',5,5'-Hexachlorobiphenyl	47 D	37 D	32 D	42 D	33 D	31 D
2,3,3',4,4',5-Hexachlorobiphenyl	-	-	-	-	-	-
2,3,3',4,4',5'-Hexachlorobiphenyl	-	-	-	-	-	-
2,3,3',4,4',6-Hexachlorobiphenyl	-	-	-	-	-	-
2,3',4,4',5,5'-Hexachlorobiphenyl	-	-	-	-	-	-
2,3',4,4',5',6-Hexachlorobiphenyl	-	-	-	-	-	-
3,3',4,4',5,5'-Hexachlorobiphenyl	-	-	-	-	-	-
2,2',3,3',4,4',5-Heptachlorobiphenyl	24 DJ	18 D	15 D	18 D	15 D	14 D
2,2',3,3',4,5',6-Heptachlorobiphenyl	-	-	-	-	-	-
2,2',3,4,4',5,5'-Heptachlorobiphenyl	24 D	19 DJ	15 DJ	21 DJ	18 DJ	17 DJ
2,2',3,4,4',5',6-Heptachlorobiphenyl	-	-	-	-	-	-
2,2',3,4,4',6,6'-Heptachlorobiphenyl	-	-	-	-	-	-
2,2',3,4',5,5',6-Heptachlorobiphenyl	29 D	23 D	18 D	23 D	18 D	21 D
2,3,3',4,4',5,5'-Heptachlorobiphenyl	-	-	-	-	-	-
2,2',3,3',4,4',5,5'-Octachlorobiphenyl	-	-	-	-	-	-
2,2',3,3',4,4',5,6-Octachlorobiphenyl	-	-	-	-	-	-

TABLE 7

POLYCHLORINATED BIPHENYLS (CONGENERS) SOLID SAMPLE DATA SUMMARY
DEMONSTRATION TESTING AND FULL-SCALE OPERATION OF THE BIOGENESIS SEDIMENT DECONTAMINATION PROCESS
KEASBEY, NEW JERSEY
 (Page 18 of 78)

Field Sample Identification	RS-190106-1600	TS-190106-1601	WS-190106-1602	RS-240106-1530	TS-240106-1630	RS-270106-1400
Sediment Source	Lower Passaic River	Lower Passaic River	Lower Passaic River	Lower Passaic River	Lower Passaic River	Lower Passaic River
Location Identification	RS	TS	WS	RS	TS	RS
Date Collected	1/19/06	1/19/06	1/19/06	1/24/06	1/24/06	1/27/06
Matrix	Solid	Solid	Solid	Solid	Solid	Solid
Analyte/Methods (Units)						
Polychlorinated Biphenyls/SW8082 (µg/kg)						
Individual Congeners (continued)						
2,2',3,3',4,5,5',6'-Octachlorobiphenyl	-	-	-	-	-	-
2,2',3,3',4,5,6,6'-Octachlorobiphenyl	-	-	-	-	-	-
2,2',3,3',5,5',6,6'-Octachlorobiphenyl	-	-	-	-	-	-
2,2',3,3',4,4',5,5',6-Nonachlorobiphenyl	6.4 TDJ	5.2 D	4.3 TD	5.8 TDJ	5.1 D	8.5 D
2,2',3,3',4,4',5,6,6'-Nonachlorobiphenyl	-	-	-	-	-	-

µg/kg micrograms per kilogram.

Bold Bolded result indicates positively identified compound.

- Not analyzed.

B Analyte detected in an associated blank.

D Sample dilution required for analysis; reported values reflect the dilution.

J Data are estimated due to associated quality control data.

T Analyte was positively identified but the reported concentration is estimated; reported concentration is less than the reporting limit, but greater than the method detection limit.

TABLE 7

POLYCHLORINATED BIPHENYLS (CONGENERS) SOLID SAMPLE DATA SUMMARY
DEMONSTRATION TESTING AND FULL-SCALE OPERATION OF THE BIOGENESIS SEDIMENT DECONTAMINATION PROCESS
KEASBEY, NEW JERSEY
 (Page 19 of 78)

Field Sample Identification	TS-270106-1401	WS-270106-1402	TS-270106-1530	WS-270106-1531	RS-300106-1700	WS2-300106-1702
Sediment Source	Lower Passaic River	Lower Passaic River	Lower Passaic River	Lower Passaic River	Raritan River	Raritan River
Location Identification	TS	WS	TS	WS	RS	WS2
Date Collected	1/27/06	1/27/06	1/27/06	1/27/06	1/30/06	1/30/06
Matrix	Solid	Solid	Solid	Solid	Solid	Solid
Analyte/Methods (Units)						
Polychlorinated Biphenyls/SW8082 (µg/kg)						
Individual Congeners						
2-Chlorobiphenyl	13 TDJ	<61 D	17 TDJ	17 TD	13 TDJ	31 TDJ
4-Chlorobiphenyl	-	-	-	-	-	-
2,3-Dichlorobiphenyl	3.5 D	2.9 TDJ	4.4 DJ	3.4 TD	<1.8 D	9.6 D
2,4'-Dichlorobiphenyl	-	-	-	-	-	-
4,4'-Dichlorobiphenyl	-	-	-	-	-	-
2,2',5-Trichlorobiphenyl	21 D	33 D	31 D	23 D	27 D	61 D
2,4,4'-Trichlorobiphenyl	-	-	-	-	-	-
2,4,5-Trichlorobiphenyl	19 D	29 D	27 D	22 D	27 D	66 D
2,4',5-Trichlorobiphenyl	-	-	-	-	-	-
3,4,4'-Trichlorobiphenyl	-	-	-	-	-	-
2,2',3,5'-Tetrachlorobiphenyl	-	-	-	-	-	-
2,2',4,5'-Tetrachlorobiphenyl	-	-	-	-	-	-
2,2',5,5'-Tetrachlorobiphenyl	23 D	32 D	30 D	23 D	27 D	58 D
2,3',4,4'-Tetrachlorobiphenyl	22 D	30 D	28 D	22 D	27 D	58 D
2,3',4',5-Tetrachlorobiphenyl	-	-	-	-	-	-
2,4,4',5-Tetrachlorobiphenyl	-	-	-	-	-	-
3,3',4,4'-Tetrachlorobiphenyl	-	-	-	-	-	-
3,4,4',5-Tetrachlorobiphenyl	-	-	-	-	-	-
2,2',3,4',5-Pentachlorobiphenyl	-	-	-	-	-	-
2,2',3,4,5'-Pentachlorobiphenyl	7.2 DJ	7.7 DJ	8 DJ	5.3 TDJ	6.2 DJ	14 DJ
2,2',4,4',5-Pentachlorobiphenyl	-	-	-	-	-	-
2,2',4,5,5'-Pentachlorobiphenyl	17 D	20 D	18 D	15 D	16 D	37 D
2,3,3',4,4'-Pentachlorobiphenyl	-	-	-	-	-	-
2,3,3',4',6-Pentachlorobiphenyl	21 D	24 D	24 D	18 D	20 D	49 D
2,3',3,5,6-Pentachlorobiphenyl	-	-	-	-	-	-
2,3,4,4',5-Pentachlorobiphenyl	-	-	-	-	-	-

TABLE 7

POLYCHLORINATED BIPHENYLS (CONGENERS) SOLID SAMPLE DATA SUMMARY
DEMONSTRATION TESTING AND FULL-SCALE OPERATION OF THE BIOGENESIS SEDIMENT DECONTAMINATION PROCESS
KEASBEY, NEW JERSEY
 (Page 20 of 78)

Field Sample Identification	TS-270106-1401	WS-270106-1402	TS-270106-1530	WS-270106-1531	RS-300106-1700	WS2-300106-1702
Sediment Source	Lower Passaic River	Lower Passaic River	Lower Passaic River	Lower Passaic River	Raritan River	Raritan River
Location Identification	TS	WS	TS	WS	RS	WS2
Date Collected	1/27/06	1/27/06	1/27/06	1/27/06	1/30/06	1/30/06
Matrix	Solid	Solid	Solid	Solid	Solid	Solid
Analyte/Methods (Units)						
Polychlorinated Biphenyls/SW8082 (µg/kg)						
Individual Congeners (continued)						
2',3,4,4',5-Pentachlorobiphenyl	-	-	-	-	-	-
2,3',4,4',5-Pentachlorobiphenyl	-	-	-	-	-	-
2,3,4,4',6-Pentachlorobiphenyl	-	-	-	-	-	-
2,3',4,4',6-Pentachlorobiphenyl	-	-	-	-	-	-
3,3',4,4',5-Pentachlorobiphenyl	-	-	-	-	-	-
2,2',3,3',4,4'-Hexachlorobiphenyl	-	-	-	-	-	-
2,2',3,4,4',5-Hexachlorobiphenyl	-	-	-	-	-	-
2,2',3,4,5,5'-Hexachlorobiphenyl	6.6 D	6.5 D	6.2 D	4.6 TD	4.1 D	12 D
2,2',3,4',5',6-Hexachlorobiphenyl	-	-	-	-	-	-
2,2',3,5,5',6-Hexachlorobiphenyl	<2.6 D	<6.1 D	<2.8 D	<6.5 D	<1.8 D	<3.3 D
2,2',4,4',5,5'-Hexachlorobiphenyl	20 D	21 D	21 D	15 D	15 D	35 D
2,3,3',4,4',5-Hexachlorobiphenyl	-	-	-	-	-	-
2,3,3',4,4',5'-Hexachlorobiphenyl	-	-	-	-	-	-
2,3,3',4,4',6-Hexachlorobiphenyl	-	-	-	-	-	-
2,3',4,4',5,5'-Hexachlorobiphenyl	-	-	-	-	-	-
2,3',4,4',5',6-Hexachlorobiphenyl	-	-	-	-	-	-
3,3',4,4',5,5'-Hexachlorobiphenyl	-	-	-	-	-	-
2,2',3,3',4,4',5-Heptachlorobiphenyl	9.8 D	9.3 D	8.4 D	6.2 TD	5.7 D	17 D
2,2',3,3',4,5',6-Heptachlorobiphenyl	-	-	-	-	-	-
2,2',3,4,4',5,5'-Heptachlorobiphenyl	11 DJ	11 DJ	9.5 DJ	8.2 DJ	6.6 DJ	21 DJ
2,2',3,4,4',5',6-Heptachlorobiphenyl	-	-	-	-	-	-
2,2',3,4,4',6,6'-Heptachlorobiphenyl	-	-	-	-	-	-
2,2',3,4',5,5',6-Heptachlorobiphenyl	11 D	12 D	11 D	8.8 D	6.8 D	21 D
2,3,3',4,4',5,5'-Heptachlorobiphenyl	-	-	-	-	-	-
2,2',3,3',4,4',5,5'-Octachlorobiphenyl	-	-	-	-	-	-
2,2',3,3',4,4',5,6-Octachlorobiphenyl	-	-	-	-	-	-

TABLE 7

POLYCHLORINATED BIPHENYLS (CONGENERS) SOLID SAMPLE DATA SUMMARY
DEMONSTRATION TESTING AND FULL-SCALE OPERATION OF THE BIOGENESIS SEDIMENT DECONTAMINATION PROCESS
KEASBEY, NEW JERSEY
 (Page 21 of 78)

Field Sample Identification	TS-270106-1401	WS-270106-1402	TS-270106-1530	WS-270106-1531	RS-300106-1700	WS2-300106-1702
Sediment Source	Lower Passaic River	Lower Passaic River	Lower Passaic River	Lower Passaic River	Raritan River	Raritan River
Location Identification	TS	WS	TS	WS	RS	WS2
Date Collected	1/27/06	1/27/06	1/27/06	1/27/06	1/30/06	1/30/06
Matrix	Solid	Solid	Solid	Solid	Solid	Solid
Analyte/Methods (Units)						
Polychlorinated Biphenyls/SW8082 (µg/kg)						
Individual Congeners (continued)						
2,2',3,3',4,5,5',6'-Octachlorobiphenyl	-	-	-	-	-	-
2,2,3,3,4,5,6,6-Octachlorobiphenyl	-	-	-	-	-	-
2,2',3,3',5,5',6,6'-Octachlorobiphenyl	-	-	-	-	-	-
2,2',3,3',4,4',5,5',6-Nonachlorobiphenyl	3.6 D	4.7 TD	2.7 TD	3.5 TD	2.4 D	6.5 D
2,2',3,3',4,4',5,6,6'-Nonachlorobiphenyl	-	-	-	-	-	-

µg/kg micrograms per kilogram.

Bold Bolded result indicates positively identified compound.

- Not analyzed.

B Analyte detected in an associated blank.

D Sample dilution required for analysis; reported values reflect the dilution.

J Data are estimated due to associated quality control data.

T Analyte was positively identified but the reported concentration is estimated; reported concentration is less than the reporting limit, but greater than the method detection limit.

TABLE 7

POLYCHLORINATED BIPHENYLS (CONGENERS) SOLID SAMPLE DATA SUMMARY
DEMONSTRATION TESTING AND FULL-SCALE OPERATION OF THE BIOGENESIS SEDIMENT DECONTAMINATION PROCESS
KEASBEY, NEW JERSEY
 (Page 22 of 78)

Field Sample Identification	RS-310106-1700	TS-310106-1701	WS-310106-1702	RS-010206-1600	TS-010206-1601	WS-010206-1602
Sediment Source	Raritan River	Raritan River	Raritan River	Raritan River	Raritan River	Raritan River
Location Identification	RS	TS	WS	RS	TS	WS
Date Collected	1/31/06	1/31/06	1/31/06	2/1/06	2/1/06	2/1/06
Matrix	Solid	Solid	Solid	Solid	Solid	Solid
Analyte/Methods (Units)						
Polychlorinated Biphenyls/SW8082 (µg/kg)						
Individual Congeners						
2-Chlorobiphenyl	<20	0.77 TDJ	<11 D	<16 D	23 DJ	<48 D
4-Chlorobiphenyl	-	-	-	-	-	-
2,3-Dichlorobiphenyl	1.2 TJ	16 D	<1.1 D	1.2 TDJ	13 D	<4.8 D
2,4'-Dichlorobiphenyl	-	-	-	-	-	-
4,4'-Dichlorobiphenyl	-	-	-	-	-	-
2,2',5-Trichlorobiphenyl	7.4 J	14 DJ	14 DJ	5.6 DJ	11 DJ	31
2,4,4'-Trichlorobiphenyl	-	-	-	-	-	-
2,4,5-Trichlorobiphenyl	7.7 J	16 DJ	10 DJ	6.2 DJ	7 DJ	32 D
2,4',5-Trichlorobiphenyl	-	-	-	-	-	-
3,4,4'-Trichlorobiphenyl	-	-	-	-	-	-
2,2',3,5'-Tetrachlorobiphenyl	-	-	-	-	-	-
2,2',4,5'-Tetrachlorobiphenyl	-	-	-	-	-	-
2,2',5,5'-Tetrachlorobiphenyl	12	18 DJ	16 DJ	8.4 D	11 D	30 D
2,3',4,4'-Tetrachlorobiphenyl	12	23 D	15 DJ	9.9 D	8.4 DJ	30 D
2,3',4',5-Tetrachlorobiphenyl	-	-	-	-	-	-
2,4,4',5-Tetrachlorobiphenyl	-	-	-	-	-	-
3,3',4,4'-Tetrachlorobiphenyl	-	-	-	-	-	-
3,4,4',5-Tetrachlorobiphenyl	-	-	-	-	-	-
2,2',3,4',5-Pentachlorobiphenyl	-	-	-	-	-	-
2,2',3,4,5'-Pentachlorobiphenyl	2.9 J	5.2 DJ	3.3 DJ	1.8 DJ	1.2 TDJ	6 DJ
2,2',4,4',5-Pentachlorobiphenyl	-	-	-	-	-	-
2,2',4,5,5'-Pentachlorobiphenyl	6	12 D	8 DJ	3.5 DJ	3.1 DJ	13 DJ
2,3,3',4,4'-Pentachlorobiphenyl	-	-	-	-	-	-
2,3,3',4',6-Pentachlorobiphenyl	8.7	15 D	10 D	6.8 D	6.5 D	23 D
2,3',3,5,6-Pentachlorobiphenyl	-	-	-	-	-	-
2,3,4,4',5-Pentachlorobiphenyl	-	-	-	-	-	-

TABLE 7

POLYCHLORINATED BIPHENYLS (CONGENERS) SOLID SAMPLE DATA SUMMARY
DEMONSTRATION TESTING AND FULL-SCALE OPERATION OF THE BIOGENESIS SEDIMENT DECONTAMINATION PROCESS
KEASBEY, NEW JERSEY
 (Page 23 of 78)

Field Sample Identification	RS-310106-1700	TS-310106-1701	WS-310106-1702	RS-010206-1600	TS-010206-1601	WS-010206-1602
Sediment Source	Raritan River	Raritan River	Raritan River	Raritan River	Raritan River	Raritan River
Location Identification	RS	TS	WS	RS	TS	WS
Date Collected	1/31/06	1/31/06	1/31/06	2/1/06	2/1/06	2/1/06
Matrix	Solid	Solid	Solid	Solid	Solid	Solid
Analyte/Methods (Units)						
Polychlorinated Biphenyls/SW8082 (µg/kg)						
Individual Congeners (continued)						
2',3,4,4',5-Pentachlorobiphenyl	-	-	-	-	-	-
2,3',4,4',5-Pentachlorobiphenyl	-	-	-	-	-	-
2,3,4,4',6-Pentachlorobiphenyl	-	-	-	-	-	-
2,3',4,4',6-Pentachlorobiphenyl	-	-	-	-	-	-
3,3',4,4',5-Pentachlorobiphenyl	-	-	-	-	-	-
2,2',3,3',4,4'-Hexachlorobiphenyl	-	-	-	-	-	-
2,2',3,4,4',5-Hexachlorobiphenyl	-	-	-	-	-	-
2,2',3,4,5,5'-Hexachlorobiphenyl	1 T	1.4 DJ	1.3 D	0.8 TD	0.56 TDJ	4.4 TD
2,2',3,4',5',6-Hexachlorobiphenyl	-	-	-	-	-	-
2,2',3,5,5',6-Hexachlorobiphenyl	<2.0	<1.4 D	<1.1 D	<1.6 D	<1.3 D	<4.8 D
2,2',4,4',5,5'-Hexachlorobiphenyl	3.1	7.9 D	4.5 D	3.2 D	2.6 DJ	15 D
2,3,3',4,4',5-Hexachlorobiphenyl	-	-	-	-	-	-
2,3,3',4,4',5'-Hexachlorobiphenyl	-	-	-	-	-	-
2,3,3',4,4',6-Hexachlorobiphenyl	-	-	-	-	-	-
2,3',4,4',5,5'-Hexachlorobiphenyl	-	-	-	-	-	-
2,3',4,4',5',6-Hexachlorobiphenyl	-	-	-	-	-	-
3,3',4,4',5,5'-Hexachlorobiphenyl	-	-	-	-	-	-
2,2',3,3',4,4',5-Heptachlorobiphenyl	0.92 TJ	2.7 D	1.5 D	1.3 TD	0.95 TDJ	6.7 D
2,2',3,3',4,4',5',6'-Heptachlorobiphenyl	-	-	-	-	-	-
2,2',3,4,4',5,5'-Heptachlorobiphenyl	1.1 TJ	2.9 DJ	2.1 DJ	1.4 TDJ	2.4 D	8 DJ
2,2',3,4,4',5',6-Heptachlorobiphenyl	-	-	-	-	-	-
2,2',3,4,4',6,6'-Heptachlorobiphenyl	-	-	-	-	-	-
2,2',3,4',5,5',6-Heptachlorobiphenyl	1.3 T	3.7 D	1.9 D	1.3 TD	0.8 TDJ	8.2 D
2,3,3',4,4',5,5'-Heptachlorobiphenyl	-	-	-	-	-	-
2,2',3,3',4,4',5,5'-Octachlorobiphenyl	-	-	-	-	-	-
2,2',3,3',4,4',5,6-Octachlorobiphenyl	-	-	-	-	-	-

TABLE 7

POLYCHLORINATED BIPHENYLS (CONGENERS) SOLID SAMPLE DATA SUMMARY
DEMONSTRATION TESTING AND FULL-SCALE OPERATION OF THE BIOGENESIS SEDIMENT DECONTAMINATION PROCESS
KEASBEY, NEW JERSEY
 (Page 24 of 78)

Field Sample Identification	RS-310106-1700	TS-310106-1701	WS-310106-1702	RS-010206-1600	TS-010206-1601	WS-010206-1602
Sediment Source	Raritan River	Raritan River	Raritan River	Raritan River	Raritan River	Raritan River
Location Identification	RS	TS	WS	RS	TS	WS
Date Collected	1/31/06	1/31/06	1/31/06	2/1/06	2/1/06	2/1/06
Matrix	Solid	Solid	Solid	Solid	Solid	Solid
Analyte/Methods (Units)						
Polychlorinated Biphenyls/SW8082 (µg/kg)						
Individual Congeners (continued)						
2,2',3,3',4,5,5',6'-Octachlorobiphenyl	-	-	-	-	-	-
2,2,3,3,4,5,6,6-Octachlorobiphenyl	-	-	-	-	-	-
2,2',3,3',5,5',6,6'-Octachlorobiphenyl	-	-	-	-	-	-
2,2',3,3',4,4',5,5',6-Nonachlorobiphenyl	0.42 TJ	0.97 TD	0.77 TD	0.79 TDJ	<1.3 D	<4.8 D
2,2',3,3',4,4',5,6,6'-Nonachlorobiphenyl	-	-	-	-	-	-

µg/kg micrograms per kilogram.

Bold Bolded result indicates positively identified compound.

- Not analyzed.

B Analyte detected in an associated blank.

D Sample dilution required for analysis; reported values reflect the dilution.

J Data are estimated due to associated quality control data.

T Analyte was positively identified but the reported concentration is estimated; reported concentration is less than the reporting limit, but greater than the method detection limit.

TABLE 7

POLYCHLORINATED BIPHENYLS (CONGENERS) SOLID SAMPLE DATA SUMMARY
DEMONSTRATION TESTING AND FULL-SCALE OPERATION OF THE BIOGENESIS SEDIMENT DECONTAMINATION PROCESS
KEASBEY, NEW JERSEY
 (Page 25 of 78)

Field Sample Identification	RS-020206-1800	TS-020206-1801	WS-020206-1802	RS-030206-1200	TS-030206-1201	WS-030206-1202
Sediment Source	Raritan River	Raritan River	Raritan River	Raritan River	Raritan River	Raritan River
Location Identification	RS	TS	WS	RS	TS	WS
Date Collected	2/2/06	2/2/06	2/2/06	2/3/06	2/3/06	2/3/06
Matrix	Solid	Solid	Solid	Solid	Solid	Solid
Analyte/Methods (Units)						
Polychlorinated Biphenyls/SW8082 (µg/kg)						
Individual Congeners						
2-Chlorobiphenyl	7.9 TJ	41 DJ	1.9 TJ	<47 D	25 TDJ	<61 D
4-Chlorobiphenyl	-	-	-	-	-	-
2,3-Dichlorobiphenyl	1.8 J	13 D	0.89 J	1.5 TDJ	35 D	<6.1 D
2,4'-Dichlorobiphenyl	-	-	-	-	-	-
4,4'-Dichlorobiphenyl	-	-	-	-	-	-
2,2',5-Trichlorobiphenyl	6.6 J	13 DJ	5.9	5.1 DJ	23 DJ	10 DJ
2,4,4'-Trichlorobiphenyl	-	-	-	-	-	-
2,4,5-Trichlorobiphenyl	6.8 J	14 D	4.1 J	<4.7 D	<2.7 D	8.9 D
2,4',5-Trichlorobiphenyl	-	-	-	-	-	-
3,4,4'-Trichlorobiphenyl	-	-	-	-	-	-
2,2',3,5'-Tetrachlorobiphenyl	-	-	-	-	-	-
2,2',4,5'-Tetrachlorobiphenyl	-	-	-	-	-	-
2,2',5,5'-Tetrachlorobiphenyl	10	42 D	5.4	8.7 D	21 DJ	17 D
2,3',4,4'-Tetrachlorobiphenyl	11	20 DJ	5.3	<4.7 D	17 DJ	<6.1 D
2,3',4',5-Tetrachlorobiphenyl	-	-	-	-	-	-
2,4,4',5-Tetrachlorobiphenyl	-	-	-	-	-	-
3,3',4,4'-Tetrachlorobiphenyl	-	-	-	-	-	-
3,4,4',5-Tetrachlorobiphenyl	-	-	-	-	-	-
2,2',3,4',5-Pentachlorobiphenyl	-	-	-	-	-	-
2,2',3,4,5'-Pentachlorobiphenyl	2 J	24 DJ	1.1 J	2.1 TDJ	<2.7 D	3.5 TDJ
2,2',4,4',5-Pentachlorobiphenyl	-	-	-	-	-	-
2,2',4,5,5'-Pentachlorobiphenyl	5.4	36 DJ	2 J	<4.7 D	<2.7 D	<6.1 D
2,3,3',4,4'-Pentachlorobiphenyl	-	-	-	-	-	-
2,3,3',4',6-Pentachlorobiphenyl	6.7	63 D	4	6.3 D	13 D	12 D
2,3',3,5,6-Pentachlorobiphenyl	-	-	-	-	-	-
2,3,4,4',5-Pentachlorobiphenyl	-	-	-	-	-	-

TABLE 7

POLYCHLORINATED BIPHENYLS (CONGENERS) SOLID SAMPLE DATA SUMMARY
DEMONSTRATION TESTING AND FULL-SCALE OPERATION OF THE BIOGENESIS SEDIMENT DECONTAMINATION PROCESS
KEASBEY, NEW JERSEY
 (Page 26 of 78)

Field Sample Identification	RS-020206-1800	TS-020206-1801	WS-020206-1802	RS-030206-1200	TS-030206-1201	WS-030206-1202
Sediment Source	Raritan River	Raritan River	Raritan River	Raritan River	Raritan River	Raritan River
Location Identification	RS	TS	WS	RS	TS	WS
Date Collected	2/2/06	2/2/06	2/2/06	2/3/06	2/3/06	2/3/06
Matrix	Solid	Solid	Solid	Solid	Solid	Solid
Analyte/Methods (Units)						
Polychlorinated Biphenyls/SW8082 (µg/kg)						
Individual Congeners (continued)						
2',3,4,4',5-Pentachlorobiphenyl	-	-	-	-	-	-
2,3',4,4',5-Pentachlorobiphenyl	-	-	-	-	-	-
2,3,4,4',6-Pentachlorobiphenyl	-	-	-	-	-	-
2,3',4,4',6-Pentachlorobiphenyl	-	-	-	-	-	-
3,3',4,4',5-Pentachlorobiphenyl	-	-	-	-	-	-
2,2',3,3',4,4'-Hexachlorobiphenyl	-	-	-	-	-	-
2,2',3,4,4',5-Hexachlorobiphenyl	-	-	-	-	-	-
2,2',3,4,5,5'-Hexachlorobiphenyl	0.87 T	21 D	0.59	<4.7 D	1.7 TDJ	1.3 TD
2,2',3,4',5',6-Hexachlorobiphenyl	-	-	-	-	-	-
2,2',3,5,5',6-Hexachlorobiphenyl	<1.1	<2.7 D	<0.53	<4.7 D	<2.7 D	<6.1 D
2,2',4,4',5,5'-Hexachlorobiphenyl	3.2	57 D	2.3	2.8 TD	5.1 DJ	5.2 TD
2,3,3',4,4',5-Hexachlorobiphenyl	-	-	-	-	-	-
2,3,3',4,4',5'-Hexachlorobiphenyl	-	-	-	-	-	-
2,3,3',4,4',6-Hexachlorobiphenyl	-	-	-	-	-	-
2,3',4,4',5,5'-Hexachlorobiphenyl	-	-	-	-	-	-
2,3',4,4',5',6-Hexachlorobiphenyl	-	-	-	-	-	-
3,3',4,4',5,5'-Hexachlorobiphenyl	-	-	-	-	-	-
2,2',3,3',4,4',5-Heptachlorobiphenyl	1.2	31 D	1.1	<4.7 D	<2.7 D	<6.1 D
2,2',3,3',4,4',5',6-Heptachlorobiphenyl	-	-	-	-	-	-
2,2',3,4,4',5,5'-Heptachlorobiphenyl	1.4 J	35 DJ	1.7	1.2 TDJ	4.7 DJ	2.3 TDJ
2,2',3,4,4',5',6-Heptachlorobiphenyl	-	-	-	-	-	-
2,2',3,4,4',6,6'-Heptachlorobiphenyl	-	-	-	-	-	-
2,2',3,4',5,5',6-Heptachlorobiphenyl	1.4	30 D	1.2	<4.7 D	<2.7 D	2.1 TD
2,3,3',4,4',5,5'-Heptachlorobiphenyl	-	-	-	-	-	-
2,2',3,3',4,4',5,5'-Octachlorobiphenyl	-	-	-	-	-	-
2,2',3,3',4,4',5,6-Octachlorobiphenyl	-	-	-	-	-	-

TABLE 7

POLYCHLORINATED BIPHENYLS (CONGENERS) SOLID SAMPLE DATA SUMMARY
DEMONSTRATION TESTING AND FULL-SCALE OPERATION OF THE BIOGENESIS SEDIMENT DECONTAMINATION PROCESS
KEASBEY, NEW JERSEY
 (Page 27 of 78)

Field Sample Identification	RS-020206-1800	TS-020206-1801	WS-020206-1802	RS-030206-1200	TS-030206-1201	WS-030206-1202
Sediment Source	Raritan River	Raritan River	Raritan River	Raritan River	Raritan River	Raritan River
Location Identification	RS	TS	WS	RS	TS	WS
Date Collected	2/2/06	2/2/06	2/2/06	2/3/06	2/3/06	2/3/06
Matrix	Solid	Solid	Solid	Solid	Solid	Solid
Analyte/Methods (Units)						
Polychlorinated Biphenyls/SW8082 (µg/kg)						
Individual Congeners (continued)						
2,2',3,3',4,5,5',6'-Octachlorobiphenyl	-	-	-	-	-	-
2,2,3,3,4,5,6,6-Octachlorobiphenyl	-	-	-	-	-	-
2,2',3,3',5,5',6,6'-Octachlorobiphenyl	-	-	-	-	-	-
2,2',3,3',4,4',5,5',6-Nonachlorobiphenyl	<1.1	<2.7 D	<0.53	<4.7 D	<2.7 D	<6.1 D
2,2',3,3',4,4',5,6,6'-Nonachlorobiphenyl	-	-	-	-	-	-

µg/kg micrograms per kilogram.

Bold Bolded result indicates positively identified compound.

- Not analyzed.

B Analyte detected in an associated blank.

D Sample dilution required for analysis; reported values reflect the dilution.

J Data are estimated due to associated quality control data.

T Analyte was positively identified but the reported concentration is estimated; reported concentration is less than the reporting limit, but greater than the method detection limit.

TABLE 7

POLYCHLORINATED BIPHENYLS (CONGENERS) SOLID SAMPLE DATA SUMMARY
DEMONSTRATION TESTING AND FULL-SCALE OPERATION OF THE BIOGENESIS SEDIMENT DECONTAMINATION PROCESS
KEASBEY, NEW JERSEY
 (Page 28 of 78)

Field Sample Identification	RS-060206-1930	TS-060206-1931	WS-060206-1932	SP-070206-1445	RS-070206-1630	TS-070206-1631
Sediment Source	Raritan River	Raritan River	Raritan River	Raritan River	Raritan River	Raritan River
Location Identification	RS	TS	WS	PPS	RS	TS
Date Collected	2/6/06	2/6/06	2/6/06	2/7/06	2/7/06	2/7/06
Matrix	Solid	Solid	Solid	Solid	Solid	Solid
Analyte/Methods (Units)						
Polychlorinated Biphenyls/SW8082 (µg/kg)						
Individual Congeners						
2-Chlorobiphenyl	<53 D	29 DJ	<58 D	88 TDJ	28 TDJ	57 D
4-Chlorobiphenyl	-	-	-	-	-	-
2,3-Dichlorobiphenyl	1.3 TDJ	8.9 D	2.1 TDJ	6.4 TDJ	4 TDJ	9.3 D
2,4'-Dichlorobiphenyl	-	-	-	-	-	-
4,4'-Dichlorobiphenyl	-	-	-	-	-	-
2,2',5-Trichlorobiphenyl	5 TDJ	6.9 DJ	12 DJ	51 D	7.3 DJ	<2.7 D
2,4,4'-Trichlorobiphenyl	-	-	-	-	-	-
2,4,5-Trichlorobiphenyl	4.7 TD	6.9 D	12 D	37 D	6.5 DJ	8.3 D
2,4',5-Trichlorobiphenyl	-	-	-	-	-	-
3,4,4'-Trichlorobiphenyl	-	-	-	-	-	-
2,2',3,5'-Tetrachlorobiphenyl	-	-	-	-	-	-
2,2',4,5'-Tetrachlorobiphenyl	-	-	-	-	-	-
2,2',5,5'-Tetrachlorobiphenyl	8.3 D	9.2 DJ	19 D	56 D	12 D	16 D
2,3',4,4'-Tetrachlorobiphenyl	8.2 D	11 D	18 D	46 D	11 D	15 D
2,3',4',5-Tetrachlorobiphenyl	-	-	-	-	-	-
2,4,4',5-Tetrachlorobiphenyl	-	-	-	-	-	-
3,3',4,4'-Tetrachlorobiphenyl	-	-	-	-	-	-
3,4,4',5-Tetrachlorobiphenyl	-	-	-	-	-	-
2,2',3,4',5-Pentachlorobiphenyl	-	-	-	-	-	-
2,2',3,4,5'-Pentachlorobiphenyl	1.9 TDJ	2.1 TDJ	3.9 TDJ	14 TDJ	2.1 TDJ	2.5 TDJ
2,2',4,4',5-Pentachlorobiphenyl	-	-	-	-	-	-
2,2',4,5,5'-Pentachlorobiphenyl	4.6 TD	5.6 D	9.9 D	34 D	3.8 TDJ	5 DJ
2,3,3',4,4'-Pentachlorobiphenyl	-	-	-	-	-	-
2,3,3',4',6-Pentachlorobiphenyl	6.1 D	6.8 D	12 D	34 D	7.9 D	9.2 D
2,3',3,5,6-Pentachlorobiphenyl	-	-	-	-	-	-
2,3,4,4',5-Pentachlorobiphenyl	-	-	-	-	-	-

TABLE 7

POLYCHLORINATED BIPHENYLS (CONGENERS) SOLID SAMPLE DATA SUMMARY
DEMONSTRATION TESTING AND FULL-SCALE OPERATION OF THE BIOGENESIS SEDIMENT DECONTAMINATION PROCESS
KEASBEY, NEW JERSEY
 (Page 29 of 78)

Field Sample Identification	RS-060206-1930	TS-060206-1931	WS-060206-1932	SP-070206-1445	RS-070206-1630	TS-070206-1631
Sediment Source	Raritan River	Raritan River	Raritan River	Raritan River	Raritan River	Raritan River
Location Identification	RS	TS	WS	PPS	RS	TS
Date Collected	2/6/06	2/6/06	2/6/06	2/7/06	2/7/06	2/7/06
Matrix	Solid	Solid	Solid	Solid	Solid	Solid
Analyte/Methods (Units)						
Polychlorinated Biphenyls/SW8082 (µg/kg)						
Individual Congeners (continued)						
2',3,4,4',5-Pentachlorobiphenyl	-	-	-	-	-	-
2,3',4,4',5-Pentachlorobiphenyl	-	-	-	-	-	-
2,3,4,4',6-Pentachlorobiphenyl	-	-	-	-	-	-
2,3',4,4',6-Pentachlorobiphenyl	-	-	-	-	-	-
3,3',4,4',5-Pentachlorobiphenyl	-	-	-	-	-	-
2,2',3,3',4,4'-Hexachlorobiphenyl	-	-	-	-	-	-
2,2',3,4,4',5-Hexachlorobiphenyl	-	-	-	-	-	-
2,2',3,4,5,5'-Hexachlorobiphenyl	0.96 TD	0.65 TDJ	1.5 TD	5.6 TD	<5.4 D	0.76 TDJ
2,2',3,4',5',6-Hexachlorobiphenyl	-	-	-	-	-	-
2,2',3,5,5',6-Hexachlorobiphenyl	<5.3 D	<2.6 D	<5.8 D	<16 D	<5.4 D	<2.7 D
2,2',4,4',5,5'-Hexachlorobiphenyl	3.4 TD	3.8 D	<5.8 D	21 D	3.5 TD	5.3 D
2,3,3',4,4',5-Hexachlorobiphenyl	-	-	-	-	-	-
2,3,3',4,4',5'-Hexachlorobiphenyl	-	-	-	-	-	-
2,3,3',4,4',6-Hexachlorobiphenyl	-	-	-	-	-	-
2,3',4,4',5,5'-Hexachlorobiphenyl	-	-	-	-	-	-
2,3',4,4',5',6-Hexachlorobiphenyl	-	-	-	-	-	-
3,3',4,4',5,5'-Hexachlorobiphenyl	-	-	-	-	-	-
2,2',3,3',4,4',5-Heptachlorobiphenyl	1.4 TD	1.2 TD	<5.8 D	6.1 TDJ	<5.4 D	1.2 TD
2,2',3,3',4,5',6'-Heptachlorobiphenyl	-	-	-	-	-	-
2,2',3,4,4',5,5'-Heptachlorobiphenyl	2.4 TD	1.8 TDJ	3 TD	10 TDJ	1.5 TD	1.8 TDJ
2,2',3,4,4',5',6-Heptachlorobiphenyl	-	-	-	-	-	-
2,2',3,4,4',6,6'-Heptachlorobiphenyl	-	-	-	-	-	-
2,2',3,4',5,5',6-Heptachlorobiphenyl	2 TD	1.3 TD	2.4 TD	11 TD	<5.4 D	1.5 TD
2,3,3',4,4',5,5'-Heptachlorobiphenyl	-	-	-	-	-	-
2,2',3,3',4,4',5,5'-Octachlorobiphenyl	-	-	-	-	-	-
2,2',3,3',4,4',5,6-Octachlorobiphenyl	-	-	-	-	-	-

TABLE 7

POLYCHLORINATED BIPHENYLS (CONGENERS) SOLID SAMPLE DATA SUMMARY
DEMONSTRATION TESTING AND FULL-SCALE OPERATION OF THE BIOGENESIS SEDIMENT DECONTAMINATION PROCESS
KEASBEY, NEW JERSEY
 (Page 30 of 78)

Field Sample Identification	RS-060206-1930	TS-060206-1931	WS-060206-1932	SP-070206-1445	RS-070206-1630	TS-070206-1631
Sediment Source	Raritan River	Raritan River	Raritan River	Raritan River	Raritan River	Raritan River
Location Identification	RS	TS	WS	PPS	RS	TS
Date Collected	2/6/06	2/6/06	2/6/06	2/7/06	2/7/06	2/7/06
Matrix	Solid	Solid	Solid	Solid	Solid	Solid
Analyte/Methods (Units)						
Polychlorinated Biphenyls/SW8082 (µg/kg)						
Individual Congeners (continued)						
2,2',3,3',4,5,5',6'-Octachlorobiphenyl	-	-	-	-	-	-
2,2,3,3,4,5,6,6-Octachlorobiphenyl	-	-	-	-	-	-
2,2',3,3',5,5',6,6'-Octachlorobiphenyl	-	-	-	-	-	-
2,2',3,3',4,4',5,5',6-Nonachlorobiphenyl	<5.3 D	<2.6 D	<5.8 D	<16 D	<5.4 D	<2.7 D
2,2',3,3',4,4',5,6,6'-Nonachlorobiphenyl	-	-	-	-	-	-

µg/kg micrograms per kilogram.

Bold Bolded result indicates positively identified compound.

- Not analyzed.

B Analyte detected in an associated blank.

D Sample dilution required for analysis; reported values reflect the dilution.

J Data are estimated due to associated quality control data.

T Analyte was positively identified but the reported concentration is estimated; reported concentration is less than the reporting limit, but greater than the method detection limit.

TABLE 7

POLYCHLORINATED BIPHENYLS (CONGENERS) SOLID SAMPLE DATA SUMMARY
DEMONSTRATION TESTING AND FULL-SCALE OPERATION OF THE BIOGENESIS SEDIMENT DECONTAMINATION PROCESS
KEASBEY, NEW JERSEY
 (Page 31 of 78)

Field Sample Identification	TS-070206-1631 DRIED	WS-070206-1632	RS-080206-1700	TS-080206-1701	WS-080206-1702	RS-090206-2300
Sediment Source	Raritan River	Raritan River	Raritan River	Raritan River	Raritan River	Arthur Kill
Location Identification	TS	WS	RS	TS	WS	RS
Date Collected	2/7/06	2/7/06	2/8/06	2/8/06	2/8/06	2/9/06
Matrix	Solid	Solid	Solid	Solid	Solid	Solid
Analyte/Methods (Units)						
Polychlorinated Biphenyls/SW8082 (µg/kg)						
Individual Congeners						
2-Chlorobiphenyl	28 D	19 TDJ	15 TDJ	13 DJ	13 TDJ	23 TDJ
4-Chlorobiphenyl	-	-	-	-	-	-
2,3-Dichlorobiphenyl	<2.2 D	2.1 TDJ	<2.5 D	5.9 D	2.5 TDJ	<2.6 D
2,4'-Dichlorobiphenyl	-	-	-	-	-	-
4,4'-Dichlorobiphenyl	-	-	-	-	-	-
2,2',5-Trichlorobiphenyl	5.2 DJ	<5.8 D	26 DJ	5.9 DJ	12 DJ	45 D
2,4,4'-Trichlorobiphenyl	-	-	-	-	-	-
2,4,5-Trichlorobiphenyl	6 D	11 DJ	19 D	7 D	<3.0 D	39 D
2,4',5-Trichlorobiphenyl	-	-	-	-	-	-
3,4,4'-Trichlorobiphenyl	-	-	-	-	-	-
2,2',3,5'-Tetrachlorobiphenyl	-	-	-	-	-	-
2,2',4,5'-Tetrachlorobiphenyl	-	-	-	-	-	-
2,2',5,5'-Tetrachlorobiphenyl	7.6 DJ	19 D	25 D	10 D	21 DJ	37 DJ
2,3',4,4'-Tetrachlorobiphenyl	9.9 D	17 D	20 D	9.7 D	19 DJ	44 D
2,3',4',5-Tetrachlorobiphenyl	-	-	-	-	-	-
2,4,4',5-Tetrachlorobiphenyl	-	-	-	-	-	-
3,3',4,4'-Tetrachlorobiphenyl	-	-	-	-	-	-
3,4,4',5-Tetrachlorobiphenyl	-	-	-	-	-	-
2,2',3,4',5-Pentachlorobiphenyl	-	-	-	-	-	-
2,2',3,4,5'-Pentachlorobiphenyl	1.7 TDJ	3.8 TDJ	4.2 DJ	1.7 DJ	3.9 DJ	12 DJ
2,2',4,4',5-Pentachlorobiphenyl	-	-	-	-	-	-
2,2',4,5,5'-Pentachlorobiphenyl	3.7 DJ	9.7 D	<2.5 D	<1.3 D	<3.0 D	<2.6 D
2,3,3',4,4'-Pentachlorobiphenyl	-	-	-	-	-	-
2,3,3',4',6-Pentachlorobiphenyl	6.1 D	12 D	11 D	5.8 D	13 D	32 D
2,3',3,5,6-Pentachlorobiphenyl	-	-	-	-	-	-
2,3,4,4',5-Pentachlorobiphenyl	-	-	-	-	-	-

TABLE 7

POLYCHLORINATED BIPHENYLS (CONGENERS) SOLID SAMPLE DATA SUMMARY
DEMONSTRATION TESTING AND FULL-SCALE OPERATION OF THE BIOGENESIS SEDIMENT DECONTAMINATION PROCESS
KEASBEY, NEW JERSEY
 (Page 32 of 78)

Field Sample Identification	TS-070206-1631 DRIED	WS-070206-1632	RS-080206-1700	TS-080206-1701	WS-080206-1702	RS-090206-2300
Sediment Source	Raritan River	Raritan River	Raritan River	Raritan River	Raritan River	Arthur Kill
Location Identification	TS	WS	RS	TS	WS	RS
Date Collected	2/7/06	2/7/06	2/8/06	2/8/06	2/8/06	2/9/06
Matrix	Solid	Solid	Solid	Solid	Solid	Solid
Analyte/Methods (Units)						
Polychlorinated Biphenyls/SW8082 (µg/kg)						
Individual Congeners (continued)						
2',3,4,4',5-Pentachlorobiphenyl	-	-	-	-	-	-
2,3',4,4',5-Pentachlorobiphenyl	-	-	-	-	-	-
2,3,4,4',6-Pentachlorobiphenyl	-	-	-	-	-	-
2,3',4,4',6-Pentachlorobiphenyl	-	-	-	-	-	-
3,3',4,4',5-Pentachlorobiphenyl	-	-	-	-	-	-
2,2',3,3',4,4'-Hexachlorobiphenyl	-	-	-	-	-	-
2,2',3,4,4',5-Hexachlorobiphenyl	-	-	-	-	-	-
2,2',3,4,5,5'-Hexachlorobiphenyl	0.55 TDJ	1.6 TD	1.2 TDJ	0.75 TD	1.6 TD	5.2 D
2,2',3,4',5',6-Hexachlorobiphenyl	-	-	-	-	-	-
2,2',3,5,5',6-Hexachlorobiphenyl	<2.2 D	<5.8 D	<2.5 D	<1.3 D	<3.0 D	<2.6 D
2,2',4,4',5,5'-Hexachlorobiphenyl	<2.2 D	5.9 D	<2.5 D	<1.3 D	<3.0 D	<2.6 D
2,3,3',4,4',5-Hexachlorobiphenyl	-	-	-	-	-	-
2,3,3',4,4',5'-Hexachlorobiphenyl	-	-	-	-	-	-
2,3,3',4,4',6-Hexachlorobiphenyl	-	-	-	-	-	-
2,3',4,4',5,5'-Hexachlorobiphenyl	-	-	-	-	-	-
2,3',4,4',5',6-Hexachlorobiphenyl	-	-	-	-	-	-
3,3',4,4',5,5'-Hexachlorobiphenyl	-	-	-	-	-	-
2,2',3,3',4,4',5-Heptachlorobiphenyl	0.73 TDJ	1.7 TD	1.1 TDJ	0.72 TD	1.6 TD	8.8 D
2,2',3,3',4,5',6'-Heptachlorobiphenyl	-	-	-	-	-	-
2,2',3,4,4',5,5'-Heptachlorobiphenyl	1.2 TDJ	3.5 TD	1.7 TDJ	1.6 D	2.4 TDJ	9.7 DJ
2,2',3,4,4',5',6-Heptachlorobiphenyl	-	-	-	-	-	-
2,2',3,4,4',6,6'-Heptachlorobiphenyl	-	-	-	-	-	-
2,2',3,4',5,5',6-Heptachlorobiphenyl	0.88 TDJ	2.5 TD	1.6 TDJ	1 TD	2.4 TD	10 D
2,3,3',4,4',5,5'-Heptachlorobiphenyl	-	-	-	-	-	-
2,2',3,3',4,4',5,5'-Octachlorobiphenyl	-	-	-	-	-	-
2,2',3,3',4,4',5,6-Octachlorobiphenyl	-	-	-	-	-	-

TABLE 7

POLYCHLORINATED BIPHENYLS (CONGENERS) SOLID SAMPLE DATA SUMMARY
DEMONSTRATION TESTING AND FULL-SCALE OPERATION OF THE BIOGENESIS SEDIMENT DECONTAMINATION PROCESS
KEASBEY, NEW JERSEY
 (Page 33 of 78)

Field Sample Identification	TS-070206-1631 DRIED	WS-070206-1632	RS-080206-1700	TS-080206-1701	WS-080206-1702	RS-090206-2300
Sediment Source	Raritan River	Raritan River	Raritan River	Raritan River	Raritan River	Arthur Kill
Location Identification	TS	WS	RS	TS	WS	RS
Date Collected	2/7/06	2/7/06	2/8/06	2/8/06	2/8/06	2/9/06
Matrix	Solid	Solid	Solid	Solid	Solid	Solid
Analyte/Methods (Units)						
Polychlorinated Biphenyls/SW8082 (µg/kg)						
Individual Congeners (continued)						
2,2',3,3',4,5,5',6'-Octachlorobiphenyl	-	-	-	-	-	-
2,2',3,3',4,5,6,6'-Octachlorobiphenyl	-	-	-	-	-	-
2,2',3,3',5,5',6,6'-Octachlorobiphenyl	-	-	-	-	-	-
2,2',3,3',4,4',5,5',6-Nonachlorobiphenyl	<2.2 D	<5.8 D	0.83 TDJ	0.46 TD	1.3 TD	4.8 D
2,2',3,3',4,4',5,6,6'-Nonachlorobiphenyl	-	-	-	-	-	-

µg/kg micrograms per kilogram.

Bold Bolded result indicates positively identified compound.

- Not analyzed.

B Analyte detected in an associated blank.

D Sample dilution required for analysis; reported values reflect the dilution.

J Data are estimated due to associated quality control data.

T Analyte was positively identified but the reported concentration is estimated; reported concentration is less than the reporting limit, but greater than the method detection limit.

TABLE 7

POLYCHLORINATED BIPHENYLS (CONGENERS) SOLID SAMPLE DATA SUMMARY
DEMONSTRATION TESTING AND FULL-SCALE OPERATION OF THE BIOGENESIS SEDIMENT DECONTAMINATION PROCESS
KEASBEY, NEW JERSEY
 (Page 34 of 78)

Field Sample Identification	TS-090206-2301	WS-090206-2302	RS-130206-1700	TS-130206-1701	WS-130206-1702	RS-140206-1330
Sediment Source	Arthur Kill	Arthur Kill	Lower Passaic River	Lower Passaic River	Lower Passaic River	Arthur Kill
Location Identification	TS	WS	RS	TS	WS	RS
Date Collected	2/9/06	2/9/06	2/13/06	2/13/06	2/13/06	2/14/06
Matrix	Solid	Solid	Solid	Solid	Solid	Solid
Analyte/Methods (Units)						
Polychlorinated Biphenyls/SW8082 (µg/kg)						
Individual Congeners						
2-Chlorobiphenyl	0.93 TDJ	21 TDJ	<70 D	31 D	5.9 TDJ	17 TDJ
4-Chlorobiphenyl	-	-	-	-	-	-
2,3-Dichlorobiphenyl	<1.3 D	<2.8 D	<7.0 D	4.5 DJ	16 DJ	<6.6 D
2,4'-Dichlorobiphenyl	-	-	-	-	-	-
4,4'-Dichlorobiphenyl	-	-	-	-	-	-
2,2',5-Trichlorobiphenyl	17 DJ	52 D	58 D	33 D	77 D	57 D
2,4,4'-Trichlorobiphenyl	-	-	-	-	-	-
2,4,5-Trichlorobiphenyl	18 D	44 D	52 D	27 D	74 D	53 D
2,4',5-Trichlorobiphenyl	-	-	-	-	-	-
3,4,4'-Trichlorobiphenyl	-	-	-	-	-	-
2,2',3,5'-Tetrachlorobiphenyl	-	-	-	-	-	-
2,2',4,5'-Tetrachlorobiphenyl	-	-	-	-	-	-
2,2',5,5'-Tetrachlorobiphenyl	18 DJ	65 D	58 D	36 D	72 DJ	48 DJ
2,3',4,4'-Tetrachlorobiphenyl	22 D	57 D	48 D	28 D	81 D	<6.6 D
2,3',4',5-Tetrachlorobiphenyl	-	-	-	-	-	-
2,4,4',5-Tetrachlorobiphenyl	-	-	-	-	-	-
3,3',4,4'-Tetrachlorobiphenyl	-	-	-	-	-	-
3,4,4',5-Tetrachlorobiphenyl	-	-	-	-	-	-
2,2',3,4',5-Pentachlorobiphenyl	-	-	-	-	-	-
2,2',3,4,5'-Pentachlorobiphenyl	5.0 DJ	15 DJ	14 DJ	7.6 DJ	22 DJ	15 DJ
2,2',4,4',5-Pentachlorobiphenyl	-	-	-	-	-	-
2,2',4,5,5'-Pentachlorobiphenyl	<1.3 D	<2.8 D	<7.0 D	17 D	54 D	<6.6 D
2,3,3',4,4'-Pentachlorobiphenyl	-	-	-	-	-	-
2,3,3',4',6-Pentachlorobiphenyl	15 D	41 D	40 D	23 D	63 D	41 D
2,3',3,5,6-Pentachlorobiphenyl	-	-	-	-	-	-
2,3,4,4',5-Pentachlorobiphenyl	-	-	-	-	-	-

TABLE 7

POLYCHLORINATED BIPHENYLS (CONGENERS) SOLID SAMPLE DATA SUMMARY
DEMONSTRATION TESTING AND FULL-SCALE OPERATION OF THE BIOGENESIS SEDIMENT DECONTAMINATION PROCESS
KEASBEY, NEW JERSEY
 (Page 35 of 78)

Field Sample Identification	TS-090206-2301	WS-090206-2302	RS-130206-1700	TS-130206-1701	WS-130206-1702	RS-140206-1330
Sediment Source	Arthur Kill	Arthur Kill	Lower Passaic River	Lower Passaic River	Lower Passaic River	Arthur Kill
Location Identification	TS	WS	RS	TS	WS	RS
Date Collected	2/9/06	2/9/06	2/13/06	2/13/06	2/13/06	2/14/06
Matrix	Solid	Solid	Solid	Solid	Solid	Solid
Analyte/Methods (Units)						
Polychlorinated Biphenyls/SW8082 (µg/kg)						
Individual Congeners (continued)						
2',3,4,4',5-Pentachlorobiphenyl	-	-	-	-	-	-
2,3',4,4',5-Pentachlorobiphenyl	-	-	-	-	-	-
2,3,4,4',6-Pentachlorobiphenyl	-	-	-	-	-	-
2,3',4,4',6-Pentachlorobiphenyl	-	-	-	-	-	-
3,3',4,4',5-Pentachlorobiphenyl	-	-	-	-	-	-
2,2',3,3',4,4'-Hexachlorobiphenyl	-	-	-	-	-	-
2,2',3,4,4',5-Hexachlorobiphenyl	-	-	-	-	-	-
2,2',3,4,5,5'-Hexachlorobiphenyl	2.1 D	6.2 D	<7.0 D	4.7 D	10 D	8.2 D
2,2',3,4',5',6-Hexachlorobiphenyl	-	-	-	-	-	-
2,2',3,5,5',6-Hexachlorobiphenyl	<1.3 D	<2.8 D	<7.0 D	1.2 TDJ	<7.0 D	<6.6 D
2,2',4,4',5,5'-Hexachlorobiphenyl	<1.3 D	<2.8 D	<7.0 D	<2.2 D	<7.0 D	<6.6 D
2,3,3',4,4',5-Hexachlorobiphenyl	-	-	-	-	-	-
2,3,3',4,4',5'-Hexachlorobiphenyl	-	-	-	-	-	-
2,3,3',4,4',6-Hexachlorobiphenyl	-	-	-	-	-	-
2,3',4,4',5,5'-Hexachlorobiphenyl	-	-	-	-	-	-
2,3',4,4',5',6-Hexachlorobiphenyl	-	-	-	-	-	-
3,3',4,4',5,5'-Hexachlorobiphenyl	-	-	-	-	-	-
2,2',3,3',4,4',5-Heptachlorobiphenyl	3.8 D	11 D	16 D	7.6 D	21 D	16 D
2,2',3,3',4,5',6-Heptachlorobiphenyl	-	-	-	-	-	-
2,2',3,4,4',5,5'-Heptachlorobiphenyl	4.2 DJ	12 DJ	16 DJ	8 DJ	22 DJ	16 DJ
2,2',3,4,4',5',6-Heptachlorobiphenyl	-	-	-	-	-	-
2,2',3,4,4',6,6'-Heptachlorobiphenyl	-	-	-	-	-	-
2,2',3,4',5,5',6-Heptachlorobiphenyl	4.5 D	12 D	18 D	8.5 D	23 D	19 D
2,3,3',4,4',5,5'-Heptachlorobiphenyl	-	-	-	-	-	-
2,2',3,3',4,4',5,5'-Octachlorobiphenyl	-	-	-	-	-	-
2,2',3,3',4,4',5,6-Octachlorobiphenyl	-	-	-	-	-	-

TABLE 7

POLYCHLORINATED BIPHENYLS (CONGENERS) SOLID SAMPLE DATA SUMMARY
DEMONSTRATION TESTING AND FULL-SCALE OPERATION OF THE BIOGENESIS SEDIMENT DECONTAMINATION PROCESS
KEASBEY, NEW JERSEY
 (Page 36 of 78)

Field Sample Identification	TS-090206-2301	WS-090206-2302	RS-130206-1700	TS-130206-1701	WS-130206-1702	RS-140206-1330
Sediment Source	Arthur Kill	Arthur Kill	Lower Passaic River	Lower Passaic River	Lower Passaic River	Arthur Kill
Location Identification	TS	WS	RS	TS	WS	RS
Date Collected	2/9/06	2/9/06	2/13/06	2/13/06	2/13/06	2/14/06
Matrix	Solid	Solid	Solid	Solid	Solid	Solid
Analyte/Methods (Units)						
Polychlorinated Biphenyls/SW8082 (µg/kg)						
Individual Congeners (continued)						
2,2',3,3',4,5,5',6'-Octachlorobiphenyl	-	-	-	-	-	-
2,2,3,3,4,5,6,6-Octachlorobiphenyl	-	-	-	-	-	-
2,2',3,3',5,5',6,6'-Octachlorobiphenyl	-	-	-	-	-	-
2,2',3,3',4,4',5,5',6-Nonachlorobiphenyl	2.2 D	6.5 D	<7.0 D	<2.2 D	<7.0 D	9.2 DJ
2,2',3,3',4,4',5,6,6'-Nonachlorobiphenyl	-	-	-	-	-	-

µg/kg micrograms per kilogram.

Bold Bolded result indicates positively identified compound.

- Not analyzed.

B Analyte detected in an associated blank.

D Sample dilution required for analysis; reported values reflect the dilution.

J Data are estimated due to associated quality control data.

T Analyte was positively identified but the reported concentration is estimated; reported concentration is less than the reporting limit, but greater than the method detection limit.

TABLE 7

POLYCHLORINATED BIPHENYLS (CONGENERS) SOLID SAMPLE DATA SUMMARY
DEMONSTRATION TESTING AND FULL-SCALE OPERATION OF THE BIOGENESIS SEDIMENT DECONTAMINATION PROCESS
KEASBEY, NEW JERSEY
 (Page 37 of 78)

Field Sample Identification	TS-140206-1331	WS-140206-1332	RS-160206-1500	TS-160206-1501	WS-160206-1502	RS-170206-1100
Sediment Source	Arthur Kill	Arthur Kill	Arthur Kill	Arthur Kill	Arthur Kill	Arthur Kill
Location Identification	TS	WS	RS	TS	WS	RS
Date Collected	2/14/06	2/14/06	2/16/06	2/16/06	2/16/06	2/17/06
Matrix	Solid	Solid	Solid	Solid	Solid	Solid
Analyte/Methods (Units)						
Polychlorinated Biphenyls/SW8082 (µg/kg)						
Individual Congeners						
2-Chlorobiphenyl	43 D	17 TDJ	<52 D	46 D	<58 D	86 D
4-Chlorobiphenyl	-	-	-	-	-	-
2,3-Dichlorobiphenyl	3.5 DJ	8.4 DJ	10 DJ	3.1 DJ	8.2 DJ	10 DJ
2,4'-Dichlorobiphenyl	-	-	-	-	-	-
4,4'-Dichlorobiphenyl	-	-	-	-	-	-
2,2',5-Trichlorobiphenyl	26 D	64 D	60 DJ	18 DJ	53 DJ	71 D
2,4,4'-Trichlorobiphenyl	-	-	-	-	-	-
2,4,5-Trichlorobiphenyl	24 D	57 D	75 D	20 D	55 DJ	85 D
2,4',5-Trichlorobiphenyl	-	-	-	-	-	-
3,4,4'-Trichlorobiphenyl	-	-	-	-	-	-
2,2',3,5'-Tetrachlorobiphenyl	-	-	-	-	-	-
2,2',4,5'-Tetrachlorobiphenyl	-	-	-	-	-	-
2,2',5,5'-Tetrachlorobiphenyl	20 DJ	53 DJ	64 DJ	18 DJ	54 DJ	57 DJ
2,3',4,4'-Tetrachlorobiphenyl	25 D	58 D	78 D	21 D	62 D	73 D
2,3',4',5-Tetrachlorobiphenyl	-	-	-	-	-	-
2,4,4',5-Tetrachlorobiphenyl	-	-	-	-	-	-
3,3',4,4'-Tetrachlorobiphenyl	-	-	-	-	-	-
3,4,4',5-Tetrachlorobiphenyl	-	-	-	-	-	-
2,2',3,4',5-Pentachlorobiphenyl	-	-	-	-	-	-
2,2',3,4,5'-Pentachlorobiphenyl	7.3 DJ	16 DJ	21 DJ	6.5 DJ	17 DJ	21 DJ
2,2',4,4',5-Pentachlorobiphenyl	-	-	-	-	-	-
2,2',4,5,5'-Pentachlorobiphenyl	<2.3 D	37 D	45 D	8.2 DJ	40 D	47 D
2,3,3',4,4'-Pentachlorobiphenyl	-	-	-	-	-	-
2,3,3',4',6-Pentachlorobiphenyl	6.6 DJ	44 D	56 D	17 D	47 D	52 D
2,3',3,5,6-Pentachlorobiphenyl	-	-	-	-	-	-
2,3,4,4',5-Pentachlorobiphenyl	-	-	-	-	-	-

TABLE 7

POLYCHLORINATED BIPHENYLS (CONGENERS) SOLID SAMPLE DATA SUMMARY
DEMONSTRATION TESTING AND FULL-SCALE OPERATION OF THE BIOGENESIS SEDIMENT DECONTAMINATION PROCESS
KEASBEY, NEW JERSEY
 (Page 38 of 78)

Field Sample Identification	TS-140206-1331	WS-140206-1332	RS-160206-1500	TS-160206-1501	WS-160206-1502	RS-170206-1100
Sediment Source	Arthur Kill	Arthur Kill	Arthur Kill	Arthur Kill	Arthur Kill	Arthur Kill
Location Identification	TS	WS	RS	TS	WS	RS
Date Collected	2/14/06	2/14/06	2/16/06	2/16/06	2/16/06	2/17/06
Matrix	Solid	Solid	Solid	Solid	Solid	Solid
Analyte/Methods (Units)						
Polychlorinated Biphenyls/SW8082 (µg/kg)						
Individual Congeners (continued)						
2',3,4,4',5-Pentachlorobiphenyl	-	-	-	-	-	-
2,3',4,4',5-Pentachlorobiphenyl	-	-	-	-	-	-
2,3,4,4',6-Pentachlorobiphenyl	-	-	-	-	-	-
2,3',4,4',6-Pentachlorobiphenyl	-	-	-	-	-	-
3,3',4,4',5-Pentachlorobiphenyl	-	-	-	-	-	-
2,2',3,3',4,4'-Hexachlorobiphenyl	-	-	-	-	-	-
2,2',3,4,4',5-Hexachlorobiphenyl	-	-	-	-	-	-
2,2',3,4,5,5'-Hexachlorobiphenyl	4.2 D	9.1 D	9.7 D	3 D	8.4 D	10 D
2,2',3,4',5',6-Hexachlorobiphenyl	-	-	-	-	-	-
2,2',3,5,5',6-Hexachlorobiphenyl	<2.3 D	1.8 TDJ	1.9 TDJ	<2.5 D	1.6 TDJ	2 TDJ
2,2',4,4',5,5'-Hexachlorobiphenyl	<2.3 D	<6.2 D	37 D	13 D	30 D	<7.4 D
2,3,3',4,4',5-Hexachlorobiphenyl	-	-	-	-	-	-
2,3,3',4,4',5'-Hexachlorobiphenyl	-	-	-	-	-	-
2,3,3',4,4',6-Hexachlorobiphenyl	-	-	-	-	-	-
2,3',4,4',5,5'-Hexachlorobiphenyl	-	-	-	-	-	-
2,3',4,4',5',6-Hexachlorobiphenyl	-	-	-	-	-	-
3,3',4,4',5,5'-Hexachlorobiphenyl	-	-	-	-	-	-
2,2',3,3',4,4',5-Heptachlorobiphenyl	11 D	16 D	17 D	5.9 D	15 D	18 D
2,2',3,3',4,5',6-Heptachlorobiphenyl	-	-	-	-	-	-
2,2',3,4,4',5,5'-Heptachlorobiphenyl	9.8 DJ	17 DJ	20 DJ	5.4 DJ	16 DJ	21 D
2,2',3,4,4',5',6-Heptachlorobiphenyl	-	-	-	-	-	-
2,2',3,4,4',6,6'-Heptachlorobiphenyl	-	-	-	-	-	-
2,2',3,4',5,5',6-Heptachlorobiphenyl	10 D	20 D	21 D	6 D	18 D	19 DJ
2,3,3',4,4',5,5'-Heptachlorobiphenyl	-	-	-	-	-	-
2,2',3,3',4,4',5,5'-Octachlorobiphenyl	-	-	-	-	-	-
2,2',3,3',4,4',5,6-Octachlorobiphenyl	-	-	-	-	-	-

TABLE 7

POLYCHLORINATED BIPHENYLS (CONGENERS) SOLID SAMPLE DATA SUMMARY
DEMONSTRATION TESTING AND FULL-SCALE OPERATION OF THE BIOGENESIS SEDIMENT DECONTAMINATION PROCESS
KEASBEY, NEW JERSEY
 (Page 39 of 78)

Field Sample Identification	TS-140206-1331	WS-140206-1332	RS-160206-1500	TS-160206-1501	WS-160206-1502	RS-170206-1100
Sediment Source	Arthur Kill	Arthur Kill	Arthur Kill	Arthur Kill	Arthur Kill	Arthur Kill
Location Identification	TS	WS	RS	TS	WS	RS
Date Collected	2/14/06	2/14/06	2/16/06	2/16/06	2/16/06	2/17/06
Matrix	Solid	Solid	Solid	Solid	Solid	Solid
Analyte/Methods (Units)						
Polychlorinated Biphenyls/SW8082 (µg/kg)						
Individual Congeners (continued)						
2,2',3,3',4,5,5',6'-Octachlorobiphenyl	-	-	-	-	-	-
2,2,3,3,4,5,6,6-Octachlorobiphenyl	-	-	-	-	-	-
2,2',3,3',5,5',6,6'-Octachlorobiphenyl	-	-	-	-	-	-
2,2',3,3',4,4',5,5',6-Nonachlorobiphenyl	3.4 DJ	8.5 DJ	13 DJ	13 DJ	8.1 DJ	9.1 D
2,2',3,3',4,4',5,6,6'-Nonachlorobiphenyl	-	-	-	-	-	-

µg/kg micrograms per kilogram.

Bold Bolded result indicates positively identified compound.

- Not analyzed.

B Analyte detected in an associated blank.

D Sample dilution required for analysis; reported values reflect the dilution.

J Data are estimated due to associated quality control data.

T Analyte was positively identified but the reported concentration is estimated; reported concentration is less than the reporting limit, but greater than the method detection limit.

TABLE 7

POLYCHLORINATED BIPHENYLS (CONGENERS) SOLID SAMPLE DATA SUMMARY
DEMONSTRATION TESTING AND FULL-SCALE OPERATION OF THE BIOGENESIS SEDIMENT DECONTAMINATION PROCESS
KEASBEY, NEW JERSEY
 (Page 40 of 78)

Field Sample Identification	TS-170206-1101	WS-170206-1102	TS-230206-0930	TS-230206-0930 DRIED	RS-270206-1400	TS-270206-1350
Sediment Source	Arthur Kill	Arthur Kill	Arthur Kill	Arthur Kill	Lower Passaic River	Lower Passaic River
Location Identification	TS	WS	TS	TS	RS	TS
Date Collected	2/17/06	2/17/06	2/23/06	2/23/06	2/27/06	2/27/06
Matrix	Solid	Solid	Solid	Solid	Solid	Solid
Analyte/Methods (Units)						
Polychlorinated Biphenyls/SW8082 (µg/kg)						
Individual Congeners						
2-Chlorobiphenyl	42 D	<70 D	35 D	30 D	42 TDJ	18 TDJ
4-Chlorobiphenyl	-	-	-	-	-	-
2,3-Dichlorobiphenyl	3.5 DJ	4.9 TDJ	<2.4 D	2.3 TDJ	14 D	3.9 DJ
2,4'-Dichlorobiphenyl	-	-	-	-	-	-
4,4'-Dichlorobiphenyl	-	-	-	-	-	-
2,2',5-Trichlorobiphenyl	25 D	34 D	19 D	16 D	65 D	26 D
2,4,4'-Trichlorobiphenyl	-	-	-	-	-	-
2,4,5-Trichlorobiphenyl	29 D	32 D	18 D	14 D	61 D	25 D
2,4',5-Trichlorobiphenyl	-	-	-	-	-	-
3,4,4'-Trichlorobiphenyl	-	-	-	-	-	-
2,2',3,5'-Tetrachlorobiphenyl	-	-	-	-	-	-
2,2',4,5'-Tetrachlorobiphenyl	-	-	-	-	-	-
2,2',5,5'-Tetrachlorobiphenyl	19 DJ	30 DJ	15 DJ	13 DJ	65 D	21 DJ
2,3',4,4'-Tetrachlorobiphenyl	24 D	35 D	20 D	15 D	56 D	24 D
2,3',4',5-Tetrachlorobiphenyl	-	-	-	-	-	-
2,4,4',5-Tetrachlorobiphenyl	-	-	-	-	-	-
3,3',4,4'-Tetrachlorobiphenyl	-	-	-	-	-	-
3,4,4',5-Tetrachlorobiphenyl	-	-	-	-	-	-
2,2',3,4',5-Pentachlorobiphenyl	-	-	-	-	-	-
2,2',3,4,5'-Pentachlorobiphenyl	6.8 DJ	9.9 DJ	6 DJ	3.7 DJ	13 DJ	5 DJ
2,2',4,4',5-Pentachlorobiphenyl	-	-	-	-	-	-
2,2',4,5,5'-Pentachlorobiphenyl	9.2 DJ	22 D	12 D	11 D	35 D	14 D
2,3,3',4,4'-Pentachlorobiphenyl	-	-	-	-	-	-
2,3,3',4',6-Pentachlorobiphenyl	18 D	27 D	15 D	11 D	44 D	18 D
2,3',3,5,6-Pentachlorobiphenyl	-	-	-	-	-	-
2,3,4,4',5-Pentachlorobiphenyl	-	-	-	-	-	-

TABLE 7

POLYCHLORINATED BIPHENYLS (CONGENERS) SOLID SAMPLE DATA SUMMARY
DEMONSTRATION TESTING AND FULL-SCALE OPERATION OF THE BIOGENESIS SEDIMENT DECONTAMINATION PROCESS
KEASBEY, NEW JERSEY
 (Page 41 of 78)

Field Sample Identification	TS-170206-1101	WS-170206-1102	TS-230206-0930	TS-230206-0930 DRIED	RS-270206-1400	TS-270206-1350
Sediment Source	Arthur Kill	Arthur Kill	Arthur Kill	Arthur Kill	Lower Passaic River	Lower Passaic River
Location Identification	TS	WS	TS	TS	RS	TS
Date Collected	2/17/06	2/17/06	2/23/06	2/23/06	2/27/06	2/27/06
Matrix	Solid	Solid	Solid	Solid	Solid	Solid
Analyte/Methods (Units)						
Polychlorinated Biphenyls/SW8082 (µg/kg)						
Individual Congeners (continued)						
2',3,4,4',5-Pentachlorobiphenyl	-	-	-	-	-	-
2,3',4,4',5-Pentachlorobiphenyl	-	-	-	-	-	-
2,3,4,4',6-Pentachlorobiphenyl	-	-	-	-	-	-
2,3',4,4',6-Pentachlorobiphenyl	-	-	-	-	-	-
3,3',4,4',5-Pentachlorobiphenyl	-	-	-	-	-	-
2,2',3,3',4,4'-Hexachlorobiphenyl	-	-	-	-	-	-
2,2',3,4,4',5-Hexachlorobiphenyl	-	-	-	-	-	-
2,2',3,4,5,5'-Hexachlorobiphenyl	3.3 D	5 TD	2.7 D	2 TD	8.9 D	3.3 D
2,2',3,4',5',6-Hexachlorobiphenyl	-	-	-	-	-	-
2,2',3,5,5',6-Hexachlorobiphenyl	<2.4 D	2.1 TDJ	<2.4 D	<2.5 D	3.5 TDJ	0.58 TDJ
2,2',4,4',5,5'-Hexachlorobiphenyl	<2.4 D	17 D	<2.4 D	<2.5 D	32 D	12 D
2,3,3',4,4',5-Hexachlorobiphenyl	-	-	-	-	-	-
2,3,3',4,4',5'-Hexachlorobiphenyl	-	-	-	-	-	-
2,3,3',4,4',6-Hexachlorobiphenyl	-	-	-	-	-	-
2,3',4,4',5,5'-Hexachlorobiphenyl	-	-	-	-	-	-
2,3',4,4',5',6-Hexachlorobiphenyl	-	-	-	-	-	-
3,3',4,4',5,5'-Hexachlorobiphenyl	-	-	-	-	-	-
2,2',3,3',4,4',5-Heptachlorobiphenyl	6.3 D	7.6 DJ	4.4 D	3.3 D	16 D	5.4 D
2,2',3,3',4,5',6'-Heptachlorobiphenyl	-	-	-	-	-	-
2,2',3,4,4',5,5'-Heptachlorobiphenyl	6 DJ	9 DJ	4.9 DJ	3.9 DJ	17 DJ	6.1 DJ
2,2',3,4,4',5',6-Heptachlorobiphenyl	-	-	-	-	-	-
2,2',3,4,4',6,6'-Heptachlorobiphenyl	-	-	-	-	-	-
2,2',3,4',5,5',6-Heptachlorobiphenyl	6.1 DJ	10 DJ	5.4 D	4.5 D	19 D	6.8 D
2,3,3',4,4',5,5'-Heptachlorobiphenyl	-	-	-	-	-	-
2,2',3,3',4,4',5,5'-Octachlorobiphenyl	-	-	-	-	-	-
2,2',3,3',4,4',5,6-Octachlorobiphenyl	-	-	-	-	-	-

TABLE 7

POLYCHLORINATED BIPHENYLS (CONGENERS) SOLID SAMPLE DATA SUMMARY
DEMONSTRATION TESTING AND FULL-SCALE OPERATION OF THE BIOGENESIS SEDIMENT DECONTAMINATION PROCESS
KEASBEY, NEW JERSEY
 (Page 42 of 78)

Field Sample Identification	TS-170206-1101	WS-170206-1102	TS-230206-0930	TS-230206-0930 DRIED	RS-270206-1400	TS-270206-1350
Sediment Source	Arthur Kill	Arthur Kill	Arthur Kill	Arthur Kill	Lower Passaic River	Lower Passaic River
Location Identification	TS	WS	TS	TS	RS	TS
Date Collected	2/17/06	2/17/06	2/23/06	2/23/06	2/27/06	2/27/06
Matrix	Solid	Solid	Solid	Solid	Solid	Solid
Analyte/Methods (Units)						
Polychlorinated Biphenyls/SW8082 (µg/kg)						
Individual Congeners (continued)						
2,2',3,3',4,5,5',6'-Octachlorobiphenyl	-	-	-	-	-	-
2,2,3,3,4,5,6,6-Octachlorobiphenyl	-	-	-	-	-	-
2,2',3,3',5,5',6,6'-Octachlorobiphenyl	-	-	-	-	-	-
2,2',3,3',4,4',5,5',6-Nonachlorobiphenyl	<2.4 D	4.4 TDJ	2.7 D	1.7 TD	5.3 TD	2.1 TD
2,2',3,3',4,4',5,6,6'-Nonachlorobiphenyl	-	-	-	-	-	-

µg/kg micrograms per kilogram.

Bold Bolded result indicates positively identified compound.

- Not analyzed.

B Analyte detected in an associated blank.

D Sample dilution required for analysis; reported values reflect the dilution.

J Data are estimated due to associated quality control data.

T Analyte was positively identified but the reported concentration is estimated; reported concentration is less than the reporting limit, but greater than the method detection limit.

TABLE 7

POLYCHLORINATED BIPHENYLS (CONGENERS) SOLID SAMPLE DATA SUMMARY
DEMONSTRATION TESTING AND FULL-SCALE OPERATION OF THE BIOGENESIS SEDIMENT DECONTAMINATION PROCESS
KEASBEY, NEW JERSEY
 (Page 43 of 78)

Field Sample Identification	TS-270206-1350 DRIED	TS-270206-1630	TS-270206-1630 DRIED	RS-280206-1700	TS-280206-1705	WS-280206-1710
Sediment Source	Lower Passaic River	Lower Passaic River	Lower Passaic River	Arthur Kill	Arthur Kill	Arthur Kill
Location Identification	TS	TS	TS	RS	TS	WS
Date Collected	2/27/06	2/27/06	2/27/06	2/28/06	2/28/06	2/28/06
Matrix	Solid	Solid	Solid	Solid	Solid	Solid
Analyte/Methods (Units)						
Polychlorinated Biphenyls/SW8082 (µg/kg)						
Individual Congeners						
2-Chlorobiphenyl	23 TDJ	22 TDJ	24 DJ	61 DJ	23 TDJ	98 DJ
4-Chlorobiphenyl	-	-	-	-	-	-
2,3-Dichlorobiphenyl	3.2 DJ	4.2 DJ	4.3 DJ	10 DJ	4.8 DJ	14 DJ
2,4'-Dichlorobiphenyl	-	-	-	-	-	-
4,4'-Dichlorobiphenyl	-	-	-	-	-	-
2,2',5-Trichlorobiphenyl	22 D	27 D	26 D	57 D	26 D	71 D
2,4,4'-Trichlorobiphenyl	-	-	-	-	-	-
2,4,5-Trichlorobiphenyl	22 D	26 D	27 D	53 D	24 D	78 D
2,4',5-Trichlorobiphenyl	-	-	-	-	-	-
3,4,4'-Trichlorobiphenyl	-	-	-	-	-	-
2,2',3,5'-Tetrachlorobiphenyl	-	-	-	-	-	-
2,2',4,5'-Tetrachlorobiphenyl	-	-	-	-	-	-
2,2',5,5'-Tetrachlorobiphenyl	19 DJ	30 D	21 DJ	43 DJ	19 DJ	58 DJ
2,3',4,4'-Tetrachlorobiphenyl	21 D	25 D	25 D	50 D	22 D	67 D
2,3',4',5-Tetrachlorobiphenyl	-	-	-	-	-	-
2,4,4',5-Tetrachlorobiphenyl	-	-	-	-	-	-
3,3',4,4'-Tetrachlorobiphenyl	-	-	-	-	-	-
3,4,4',5-Tetrachlorobiphenyl	-	-	-	-	-	-
2,2',3,4',5-Pentachlorobiphenyl	-	-	-	-	-	-
2,2',3,4,5'-Pentachlorobiphenyl	5 DJ	5.6 DJ	6 DJ	11 DJ	4.9 DJ	14 DJ
2,2',4,4',5-Pentachlorobiphenyl	-	-	-	-	-	-
2,2',4,5,5'-Pentachlorobiphenyl	13 D	15 D	17 D	<5.6 D	<2.5 D	<6.7 D
2,3,3',4,4'-Pentachlorobiphenyl	-	-	-	-	-	-
2,3,3',4',6-Pentachlorobiphenyl	17 D	19 D	19 D	34 D	16 D	47 D
2,3',3,5,6-Pentachlorobiphenyl	-	-	-	-	-	-
2,3,4,4',5-Pentachlorobiphenyl	-	-	-	-	-	-

TABLE 7

POLYCHLORINATED BIPHENYLS (CONGENERS) SOLID SAMPLE DATA SUMMARY
DEMONSTRATION TESTING AND FULL-SCALE OPERATION OF THE BIOGENESIS SEDIMENT DECONTAMINATION PROCESS
KEASBEY, NEW JERSEY
 (Page 44 of 78)

Field Sample Identification	TS-270206-1350 DRIED	TS-270206-1630	TS-270206-1630 DRIED	RS-280206-1700	TS-280206-1705	WS-280206-1710
Sediment Source	Lower Passaic River	Lower Passaic River	Lower Passaic River	Arthur Kill	Arthur Kill	Arthur Kill
Location Identification	TS	TS	TS	RS	TS	WS
Date Collected	2/27/06	2/27/06	2/27/06	2/28/06	2/28/06	2/28/06
Matrix	Solid	Solid	Solid	Solid	Solid	Solid
Analyte/Methods (Units)						
Polychlorinated Biphenyls/SW8082 (µg/kg)						
Individual Congeners (continued)						
2',3,4,4',5-Pentachlorobiphenyl	-	-	-	-	-	-
2,3',4,4',5-Pentachlorobiphenyl	-	-	-	-	-	-
2,3,4,4',6-Pentachlorobiphenyl	-	-	-	-	-	-
2,3',4,4',6-Pentachlorobiphenyl	-	-	-	-	-	-
3,3',4,4',5-Pentachlorobiphenyl	-	-	-	-	-	-
2,2',3,3',4,4'-Hexachlorobiphenyl	-	-	-	-	-	-
2,2',3,4,4',5-Hexachlorobiphenyl	-	-	-	-	-	-
2,2',3,4,5,5'-Hexachlorobiphenyl	3.2 D	3.7 D	3.5 D	5.7 D	2.4 TD	8.1 D
2,2',3,4',5',6-Hexachlorobiphenyl	-	-	-	-	-	-
2,2',3,5,5',6-Hexachlorobiphenyl	0.64 TDJ	1 TDJ	1.2 TDJ	1.1 TDJ	<2.5 D	1.4 TDJ
2,2',4,4',5,5'-Hexachlorobiphenyl	13 D	13 D	13 D	21 D	<2.5 D	30 D
2,3,3',4,4',5-Hexachlorobiphenyl	-	-	-	-	-	-
2,3,3',4,4',5'-Hexachlorobiphenyl	-	-	-	-	-	-
2,3,3',4,4',6-Hexachlorobiphenyl	-	-	-	-	-	-
2,3',4,4',5,5'-Hexachlorobiphenyl	-	-	-	-	-	-
2,3',4,4',5',6-Hexachlorobiphenyl	-	-	-	-	-	-
3,3',4,4',5,5'-Hexachlorobiphenyl	-	-	-	-	-	-
2,2',3,3',4,4',5-Heptachlorobiphenyl	5.1 D	5.9 D	6.1 D	9.7 D	4 D	14 D
2,2',3,3',4,5',6-Heptachlorobiphenyl	-	-	-	-	-	-
2,2',3,4,4',5,5'-Heptachlorobiphenyl	6.1 DJ	6.9 DJ	7.2 DJ	11 DJ	5 DJ	16 DJ
2,2',3,4,4',5',6-Heptachlorobiphenyl	-	-	-	-	-	-
2,2',3,4,4',6,6'-Heptachlorobiphenyl	-	-	-	-	-	-
2,2',3,4',5,5',6-Heptachlorobiphenyl	6.6 D	7.5 D	7.9 D	12 D	5.7 D	17 D
2,3,3',4,4',5,5'-Heptachlorobiphenyl	-	-	-	-	-	-
2,2',3,3',4,4',5,5'-Octachlorobiphenyl	-	-	-	-	-	-
2,2',3,3',4,4',5,6-Octachlorobiphenyl	-	-	-	-	-	-

TABLE 7

POLYCHLORINATED BIPHENYLS (CONGENERS) SOLID SAMPLE DATA SUMMARY
DEMONSTRATION TESTING AND FULL-SCALE OPERATION OF THE BIOGENESIS SEDIMENT DECONTAMINATION PROCESS
KEASBEY, NEW JERSEY
 (Page 45 of 78)

Field Sample Identification	TS-270206-1350 DRIED	TS-270206-1630	TS-270206-1630 DRIED	RS-280206-1700	TS-280206-1705	WS-280206-1710
Sediment Source	Lower Passaic River	Lower Passaic River	Lower Passaic River	Arthur Kill	Arthur Kill	Arthur Kill
Location Identification	TS	TS	TS	RS	TS	WS
Date Collected	2/27/06	2/27/06	2/27/06	2/28/06	2/28/06	2/28/06
Matrix	Solid	Solid	Solid	Solid	Solid	Solid
Analyte/Methods (Units)						
Polychlorinated Biphenyls/SW8082 (µg/kg)						
Individual Congeners (continued)						
2,2',3,3',4,5,5',6'-Octachlorobiphenyl	-	-	-	-	-	-
2,2,3,3,4,5,6,6-Octachlorobiphenyl	-	-	-	-	-	-
2,2',3,3',5,5',6,6'-Octachlorobiphenyl	-	-	-	-	-	-
2,2',3,3',4,4',5,5',6-Nonachlorobiphenyl	2.6 D	2.4 D	2.6 D	8 D	1.7 TDJ	8.4 D
2,2',3,3',4,4',5,6,6'-Nonachlorobiphenyl	-	-	-	-	-	-

µg/kg micrograms per kilogram.

Bold Bolded result indicates positively identified compound.

- Not analyzed.

B Analyte detected in an associated blank.

D Sample dilution required for analysis; reported values reflect the dilution.

J Data are estimated due to associated quality control data.

T Analyte was positively identified but the reported concentration is estimated; reported concentration is less than the reporting limit, but greater than the method detection limit.

TABLE 7

POLYCHLORINATED BIPHENYLS (CONGENERS) SOLID SAMPLE DATA SUMMARY
DEMONSTRATION TESTING AND FULL-SCALE OPERATION OF THE BIOGENESIS SEDIMENT DECONTAMINATION PROCESS
KEASBEY, NEW JERSEY
 (Page 46 of 78)

Field Sample Identification	RS-010306-1700	TS-010306-1705	WS-010306-1710	SS-020306-1400	RS-020306-1700	TS-020306-1705
Sediment Source	Arthur Kill	Arthur Kill	Arthur Kill	Arthur Kill	Arthur Kill	Arthur Kill
Location Identification	RS	TS	WS	SS1	RS	TS
Date Collected	3/1/06	3/1/06	3/1/06	3/2/06	3/2/06	3/2/06
Matrix	Solid	Solid	Solid	Solid	Solid	Solid
Analyte/Methods (Units)						
Polychlorinated Biphenyls/SW8082 (µg/kg)						
Individual Congeners						
2-Chlorobiphenyl	59 TDJ	44 DJ	79 DJ	370 DJB	67 TDJB	24 TDJB
4-Chlorobiphenyl	-	-	-	-	-	-
2,3-Dichlorobiphenyl	10 DJ	9.6 DJ	12 DJ	77 D	10 DJ	5.9 DJ
2,4'-Dichlorobiphenyl	-	-	-	-	-	-
4,4'-Dichlorobiphenyl	-	-	-	-	-	-
2,2',5-Trichlorobiphenyl	57 D	44 D	65 D	280 D	54 D	30 D
2,4,4'-Trichlorobiphenyl	-	-	-	-	-	-
2,4,5-Trichlorobiphenyl	52 D	40 D	60 D	180 D	50 D	29 D
2,4',5-Trichlorobiphenyl	-	-	-	-	-	-
3,4,4'-Trichlorobiphenyl	-	-	-	-	-	-
2,2',3,5'-Tetrachlorobiphenyl	-	-	-	-	-	-
2,2',4,5'-Tetrachlorobiphenyl	-	-	-	-	-	-
2,2',5,5'-Tetrachlorobiphenyl	44 DJ	34 DJ	49 DJ	83 DJ	44 DJ	23 DJ
2,3',4,4'-Tetrachlorobiphenyl	53 D	40 D	58 D	83 D	50 D	27 D
2,3',4',5-Tetrachlorobiphenyl	-	-	-	-	-	-
2,4,4',5-Tetrachlorobiphenyl	-	-	-	-	-	-
3,3',4,4'-Tetrachlorobiphenyl	-	-	-	-	-	-
3,4,4',5-Tetrachlorobiphenyl	-	-	-	-	-	-
2,2',3,4',5-Pentachlorobiphenyl	-	-	-	-	-	-
2,2',3,4,5'-Pentachlorobiphenyl	12 DJ	7.8 DJ	13 DJ	19 DJ	10 DJ	6.6 DJ
2,2',4,4',5-Pentachlorobiphenyl	-	-	-	-	-	-
2,2',4,5,5'-Pentachlorobiphenyl	<6.6 D	<2.7 D	<6.3 D	<3.6 D	<7.1 D	<2.9 D
2,3,3',4,4'-Pentachlorobiphenyl	-	-	-	-	-	-
2,3,3',4',6-Pentachlorobiphenyl	37 D	28 D	42 D	40 D	36 D	19 D
2,3',3,5,6-Pentachlorobiphenyl	-	-	-	-	-	-
2,3,4,4',5-Pentachlorobiphenyl	-	-	-	-	-	-

TABLE 7

POLYCHLORINATED BIPHENYLS (CONGENERS) SOLID SAMPLE DATA SUMMARY
DEMONSTRATION TESTING AND FULL-SCALE OPERATION OF THE BIOGENESIS SEDIMENT DECONTAMINATION PROCESS
KEASBEY, NEW JERSEY
 (Page 47 of 78)

Field Sample Identification	RS-010306-1700	TS-010306-1705	WS-010306-1710	SS-020306-1400	RS-020306-1700	TS-020306-1705
Sediment Source	Arthur Kill	Arthur Kill	Arthur Kill	Arthur Kill	Arthur Kill	Arthur Kill
Location Identification	RS	TS	WS	SS1	RS	TS
Date Collected	3/1/06	3/1/06	3/1/06	3/2/06	3/2/06	3/2/06
Matrix	Solid	Solid	Solid	Solid	Solid	Solid
Analyte/Methods (Units)						
Polychlorinated Biphenyls/SW8082 (µg/kg)						
Individual Congeners (continued)						
2',3,4,4',5-Pentachlorobiphenyl	-	-	-	-	-	-
2,3',4,4',5-Pentachlorobiphenyl	-	-	-	-	-	-
2,3,4,4',6-Pentachlorobiphenyl	-	-	-	-	-	-
2,3',4,4',6-Pentachlorobiphenyl	-	-	-	-	-	-
3,3',4,4',5-Pentachlorobiphenyl	-	-	-	-	-	-
2,2',3,3',4,4'-Hexachlorobiphenyl	-	-	-	-	-	-
2,2',3,4,4',5-Hexachlorobiphenyl	-	-	-	-	-	-
2,2',3,4,5,5'-Hexachlorobiphenyl	6.1 TD	4.1 D	6.9 D	4.8 D	5.8 TD	2.9 D
2,2',3,4',5',6-Hexachlorobiphenyl	-	-	-	-	-	-
2,2',3,5,5',6-Hexachlorobiphenyl	<6.6 D	<2.7 D	<6.3 D	<3.6 D	<7.1 D	<2.9 D
2,2',4,4',5,5'-Hexachlorobiphenyl	23 D	16 D	25 D	16 D	22 D	12 D
2,3,3',4,4',5-Hexachlorobiphenyl	-	-	-	-	-	-
2,3,3',4,4',5'-Hexachlorobiphenyl	-	-	-	-	-	-
2,3,3',4,4',6-Hexachlorobiphenyl	-	-	-	-	-	-
2,3',4,4',5,5'-Hexachlorobiphenyl	-	-	-	-	-	-
2,3',4,4',5',6-Hexachlorobiphenyl	-	-	-	-	-	-
3,3',4,4',5,5'-Hexachlorobiphenyl	-	-	-	-	-	-
2,2',3,3',4,4',5-Heptachlorobiphenyl	10 D	6.7 D	11 D	6 DJ	10 D	5.2 D
2,2',3,3',4,5',6-Heptachlorobiphenyl	-	-	-	-	-	-
2,2',3,4,4',5,5'-Heptachlorobiphenyl	18 DJ	7.9 DJ	14 DJ	8.1 DJ	12 DJ	5.8 DJ
2,2',3,4,4',5',6-Heptachlorobiphenyl	-	-	-	-	-	-
2,2',3,4,4',6,6'-Heptachlorobiphenyl	-	-	-	-	-	-
2,2',3,4',5,5',6-Heptachlorobiphenyl	14 D	8.6 D	15 D	10 D	12 D	6.2 D
2,3,3',4,4',5,5'-Heptachlorobiphenyl	-	-	-	-	-	-
2,2',3,3',4,4',5,5'-Octachlorobiphenyl	-	-	-	-	-	-
2,2',3,3',4,4',5,6-Octachlorobiphenyl	-	-	-	-	-	-

TABLE 7

POLYCHLORINATED BIPHENYLS (CONGENERS) SOLID SAMPLE DATA SUMMARY
DEMONSTRATION TESTING AND FULL-SCALE OPERATION OF THE BIOGENESIS SEDIMENT DECONTAMINATION PROCESS
KEASBEY, NEW JERSEY
 (Page 48 of 78)

Field Sample Identification	RS-010306-1700	TS-010306-1705	WS-010306-1710	SS-020306-1400	RS-020306-1700	TS-020306-1705
Sediment Source	Arthur Kill	Arthur Kill	Arthur Kill	Arthur Kill	Arthur Kill	Arthur Kill
Location Identification	RS	TS	WS	SS1	RS	TS
Date Collected	3/1/06	3/1/06	3/1/06	3/2/06	3/2/06	3/2/06
Matrix	Solid	Solid	Solid	Solid	Solid	Solid
Analyte/Methods (Units)						
Polychlorinated Biphenyls/SW8082 (µg/kg)						
Individual Congeners (continued)						
2,2',3,3',4,5,5',6'-Octachlorobiphenyl	-	-	-	-	-	-
2,2,3,3,4,5,6,6-Octachlorobiphenyl	-	-	-	-	-	-
2,2',3,3',5,5',6,6'-Octachlorobiphenyl	-	-	-	-	-	-
2,2',3,3',4,4',5,5',6-Nonachlorobiphenyl	7.1 D	3.7 D	7.8 D	<3.6 D	6.5 TD	3 D
2,2',3,3',4,4',5,6,6'-Nonachlorobiphenyl	-	-	-	-	-	-

µg/kg micrograms per kilogram.

Bold Bolded result indicates positively identified compound.

- Not analyzed.

B Analyte detected in an associated blank.

D Sample dilution required for analysis; reported values reflect the dilution.

J Data are estimated due to associated quality control data.

T Analyte was positively identified but the reported concentration is estimated; reported concentration is less than the reporting limit, but greater than the method detection limit.

TABLE 7

POLYCHLORINATED BIPHENYLS (CONGENERS) SOLID SAMPLE DATA SUMMARY
DEMONSTRATION TESTING AND FULL-SCALE OPERATION OF THE BIOGENESIS SEDIMENT DECONTAMINATION PROCESS
KEASBEY, NEW JERSEY
 (Page 49 of 78)

Field Sample Identification	WS-020306-1710	RS-030306-1200	TS-030306-1205	WS-030306-1210	RS-060406-1215	TS-060406-1240
Sediment Source	Arthur Kill	Arthur Kill	Arthur Kill	Arthur Kill	Arthur Kill	Arthur Kill
Location Identification	WS	RS	TS	WS	RS	TS
Date Collected	3/2/06	3/3/06	3/3/06	3/3/06	4/6/06	4/6/06
Matrix	Solid	Solid	Solid	Solid	Solid	Solid
Analyte/Methods (Units)						
Polychlorinated Biphenyls/SW8082 (µg/kg)						
Individual Congeners						
2-Chlorobiphenyl	56 TDJB	100 D	30 DJ	68 D	36 DJ	18 DJ
4-Chlorobiphenyl	-	-	-	-	-	-
2,3-Dichlorobiphenyl	14 DJ	11 DJ	5.1 DJ	6.4 DJ	<2.9 D	<1.3 D
2,4'-Dichlorobiphenyl	-	-	-	-	-	-
4,4'-Dichlorobiphenyl	-	-	-	-	-	-
2,2',5-Trichlorobiphenyl	76 D	41 D	29 D	36 D	45 D	29 DJ
2,4,4'-Trichlorobiphenyl	-	-	-	-	-	-
2,4,5-Trichlorobiphenyl	70 D	34 D	23 D	32 D	46 D	30 D
2,4',5-Trichlorobiphenyl	-	-	-	-	-	-
3,4,4'-Trichlorobiphenyl	-	-	-	-	-	-
2,2',3,5'-Tetrachlorobiphenyl	-	-	-	-	-	-
2,2',4,5'-Tetrachlorobiphenyl	-	-	-	-	-	-
2,2',5,5'-Tetrachlorobiphenyl	56 DJ	31 DJ	20 DJ	30 DJ	38 DJ	24 DJ
2,3',4,4'-Tetrachlorobiphenyl	68 D	38 D	22 D	33 D	46 D	28 DJ
2,3',4',5-Tetrachlorobiphenyl	-	-	-	-	-	-
2,4,4',5-Tetrachlorobiphenyl	-	-	-	-	-	-
3,3',4,4'-Tetrachlorobiphenyl	-	-	-	-	-	-
3,4,4',5-Tetrachlorobiphenyl	-	-	-	-	-	-
2,2',3,4',5-Pentachlorobiphenyl	-	-	-	-	-	-
2,2',3,4,5'-Pentachlorobiphenyl	15 DJ	8.4 DJ	5.1 DJ	7.9 DJ	11 DJ	6.2 DJ
2,2',4,4',5-Pentachlorobiphenyl	-	-	-	-	-	-
2,2',4,5,5'-Pentachlorobiphenyl	<6.5 D	<8.1 D	<2.9 D	<6.0 D	28 D	<1.3 D
2,3,3',4,4'-Pentachlorobiphenyl	-	-	-	-	-	-
2,3,3',4',6-Pentachlorobiphenyl	48 D	27 D	16 D	23 D	33 D	20 D
2,3',3,5,6-Pentachlorobiphenyl	-	-	-	-	-	-
2,3,4,4',5-Pentachlorobiphenyl	-	-	-	-	-	-

TABLE 7

POLYCHLORINATED BIPHENYLS (CONGENERS) SOLID SAMPLE DATA SUMMARY
DEMONSTRATION TESTING AND FULL-SCALE OPERATION OF THE BIOGENESIS SEDIMENT DECONTAMINATION PROCESS
KEASBEY, NEW JERSEY
 (Page 50 of 78)

Field Sample Identification	WS-020306-1710	RS-030306-1200	TS-030306-1205	WS-030306-1210	RS-060406-1215	TS-060406-1240
Sediment Source	Arthur Kill	Arthur Kill	Arthur Kill	Arthur Kill	Arthur Kill	Arthur Kill
Location Identification	WS	RS	TS	WS	RS	TS
Date Collected	3/2/06	3/3/06	3/3/06	3/3/06	4/6/06	4/6/06
Matrix	Solid	Solid	Solid	Solid	Solid	Solid
Analyte/Methods (Units)						
Polychlorinated Biphenyls/SW8082 (µg/kg)						
Individual Congeners (continued)						
2',3,4,4',5-Pentachlorobiphenyl	-	-	-	-	-	-
2,3',4,4',5-Pentachlorobiphenyl	-	-	-	-	-	-
2,3,4,4',6-Pentachlorobiphenyl	-	-	-	-	-	-
2,3',4,4',6-Pentachlorobiphenyl	-	-	-	-	-	-
3,3',4,4',5-Pentachlorobiphenyl	-	-	-	-	-	-
2,2',3,3',4,4'-Hexachlorobiphenyl	-	-	-	-	-	-
2,2',3,4,4',5-Hexachlorobiphenyl	-	-	-	-	-	-
2,2',3,4,5,5'-Hexachlorobiphenyl	7.9 D	4.2 TDJ	2.8 TD	4.1 TD	5.8 D	3.3 D
2,2',3,4',5',6-Hexachlorobiphenyl	-	-	-	-	-	-
2,2',3,5,5',6-Hexachlorobiphenyl	<6.5 D	<8.1 D	<2.9 D	<6.0 D	<2.9 D	<1.3 D
2,2',4,4',5,5'-Hexachlorobiphenyl	29 D	17 D	10 D	16 D	22 DJ	14 DJ
2,3,3',4,4',5-Hexachlorobiphenyl	-	-	-	-	-	-
2,3,3',4,4',5'-Hexachlorobiphenyl	-	-	-	-	-	-
2,3,3',4,4',6-Hexachlorobiphenyl	-	-	-	-	-	-
2,3',4,4',5,5'-Hexachlorobiphenyl	-	-	-	-	-	-
2,3',4,4',5',6-Hexachlorobiphenyl	-	-	-	-	-	-
3,3',4,4',5,5'-Hexachlorobiphenyl	-	-	-	-	-	-
2,2',3,3',4,4',5-Heptachlorobiphenyl	13 D	7 TD	4.2 D	6.8 D	9.3 D	5.6 D
2,2',3,3',4,4',5',6-Heptachlorobiphenyl	-	-	-	-	-	-
2,2',3,4,4',5,5'-Heptachlorobiphenyl	16 DJ	8.6 DJ	5 DJ	7.9 DJ	11 DJ	6.9 DJ
2,2',3,4,4',5',6-Heptachlorobiphenyl	-	-	-	-	-	-
2,2',3,4,4',6,6'-Heptachlorobiphenyl	-	-	-	-	-	-
2,2',3,4',5,5',6-Heptachlorobiphenyl	17 D	11 D	5.6 D	9.1 D	12 DJ	7.4 DJ
2,3,3',4,4',5,5'-Heptachlorobiphenyl	-	-	-	-	-	-
2,2',3,3',4,4',5,5'-Octachlorobiphenyl	-	-	-	-	-	-
2,2',3,3',4,4',5,6-Octachlorobiphenyl	-	-	-	-	-	-

TABLE 7

POLYCHLORINATED BIPHENYLS (CONGENERS) SOLID SAMPLE DATA SUMMARY
DEMONSTRATION TESTING AND FULL-SCALE OPERATION OF THE BIOGENESIS SEDIMENT DECONTAMINATION PROCESS
KEASBEY, NEW JERSEY
 (Page 51 of 78)

Field Sample Identification	WS-020306-1710	RS-030306-1200	TS-030306-1205	WS-030306-1210	RS-060406-1215	TS-060406-1240
Sediment Source	Arthur Kill	Arthur Kill	Arthur Kill	Arthur Kill	Arthur Kill	Arthur Kill
Location Identification	WS	RS	TS	WS	RS	TS
Date Collected	3/2/06	3/3/06	3/3/06	3/3/06	4/6/06	4/6/06
Matrix	Solid	Solid	Solid	Solid	Solid	Solid
Analyte/Methods (Units)						
Polychlorinated Biphenyls/SW8082 (µg/kg)						
Individual Congeners (continued)						
2,2',3,3',4,5,5',6'-Octachlorobiphenyl	-	-	-	-	-	-
2,2,3,3,4,5,6,6-Octachlorobiphenyl	-	-	-	-	-	-
2,2',3,3',5,5',6,6'-Octachlorobiphenyl	-	-	-	-	-	-
2,2',3,3',4,4',5,5',6-Nonachlorobiphenyl	8.9 D	4.5 TD	5.2 D	4.5 TD	4.8 D	2.5 DJ
2,2',3,3',4,4',5,6,6'-Nonachlorobiphenyl	-	-	-	-	-	-

µg/kg micrograms per kilogram.

Bold Bolded result indicates positively identified compound.

- Not analyzed.

B Analyte detected in an associated blank.

D Sample dilution required for analysis; reported values reflect the dilution.

J Data are estimated due to associated quality control data.

T Analyte was positively identified but the reported concentration is estimated; reported concentration is less than the reporting limit, but greater than the method detection limit.

TABLE 7

POLYCHLORINATED BIPHENYLS (CONGENERS) SOLID SAMPLE DATA SUMMARY
DEMONSTRATION TESTING AND FULL-SCALE OPERATION OF THE BIOGENESIS SEDIMENT DECONTAMINATION PROCESS
KEASBEY, NEW JERSEY
 (Page 52 of 78)

Field Sample Identification	WS-060406-1300	RS-100406-1525	TS-100406-1615	WS-100406-1630	RS-120406-1815	TS-120406-1835
Sediment Source	Arthur Kill	Arthur Kill	Arthur Kill	Arthur Kill	Arthur Kill	Arthur Kill
Location Identification	WS	RS	TS	WS	RS	TS
Date Collected	4/6/06	4/10/06	4/10/06	4/10/06	4/12/06	4/12/06
Matrix	Solid	Solid	Solid	Solid	Solid	Solid
Analyte/Methods (Units)						
Polychlorinated Biphenyls/SW8082 (µg/kg)						
Individual Congeners						
2-Chlorobiphenyl	150 D	43 TDJ	19 TDJ	62 DJ	41 TDJ	15 TDJ
4-Chlorobiphenyl	-	-	-	-	-	-
2,3-Dichlorobiphenyl	15 DJ	<4.6 D	4.6 DJ	<5.2 D	3.1 TDJ	<2.1 D
2,4'-Dichlorobiphenyl	-	-	-	-	-	-
4,4'-Dichlorobiphenyl	-	-	-	-	-	-
2,2',5-Trichlorobiphenyl	100 D	49 D	26 D	78 D	38 D	28 D
2,4,4'-Trichlorobiphenyl	-	-	-	-	-	-
2,4,5-Trichlorobiphenyl	110 D	55 D	29 D	86 D	40 DJ	30 DJ
2,4',5-Trichlorobiphenyl	-	-	-	-	-	-
3,4,4'-Trichlorobiphenyl	-	-	-	-	-	-
2,2',3,5'-Tetrachlorobiphenyl	-	-	-	-	-	-
2,2',4,5'-Tetrachlorobiphenyl	-	-	-	-	-	-
2,2',5,5'-Tetrachlorobiphenyl	85 DJ	45 DJ	21 DJ	66 DJ	33 DJ	23 DJ
2,3',4,4'-Tetrachlorobiphenyl	100 D	54 D	26 D	80 D	40 D	29 D
2,3',4',5-Tetrachlorobiphenyl	-	-	-	-	-	-
2,4,4',5-Tetrachlorobiphenyl	-	-	-	-	-	-
3,3',4,4'-Tetrachlorobiphenyl	-	-	-	-	-	-
3,4,4',5-Tetrachlorobiphenyl	-	-	-	-	-	-
2,2',3,4',5-Pentachlorobiphenyl	-	-	-	-	-	-
2,2',3,4,5'-Pentachlorobiphenyl	23 DJ	13 DJ	6 DJ	17 DJ	9 DJ	6.4 DJ
2,2',4,4',5-Pentachlorobiphenyl	-	-	-	-	-	-
2,2',4,5,5'-Pentachlorobiphenyl	<3.2 D	32 D	<2.0 D	<5.2 D	23 D	<2.1 D
2,3,3',4,4'-Pentachlorobiphenyl	-	-	-	-	-	-
2,3,3',4',6-Pentachlorobiphenyl	72 D	40 D	19 D	55 D	28 D	21 D
2,3',3,5,6-Pentachlorobiphenyl	-	-	-	-	-	-
2,3,4,4',5-Pentachlorobiphenyl	-	-	-	-	-	-

TABLE 7

POLYCHLORINATED BIPHENYLS (CONGENERS) SOLID SAMPLE DATA SUMMARY
DEMONSTRATION TESTING AND FULL-SCALE OPERATION OF THE BIOGENESIS SEDIMENT DECONTAMINATION PROCESS
KEASBEY, NEW JERSEY
 (Page 53 of 78)

Field Sample Identification	WS-060406-1300	RS-100406-1525	TS-100406-1615	WS-100406-1630	RS-120406-1815	TS-120406-1835
Sediment Source	Arthur Kill	Arthur Kill	Arthur Kill	Arthur Kill	Arthur Kill	Arthur Kill
Location Identification	WS	RS	TS	WS	RS	TS
Date Collected	4/6/06	4/10/06	4/10/06	4/10/06	4/12/06	4/12/06
Matrix	Solid	Solid	Solid	Solid	Solid	Solid
Analyte/Methods (Units)						
Polychlorinated Biphenyls/SW8082 (µg/kg)						
Individual Congeners (continued)						
2',3,4,4',5-Pentachlorobiphenyl	-	-	-	-	-	-
2,3',4,4',5-Pentachlorobiphenyl	-	-	-	-	-	-
2,3,4,4',6-Pentachlorobiphenyl	-	-	-	-	-	-
2,3',4,4',6-Pentachlorobiphenyl	-	-	-	-	-	-
3,3',4,4',5-Pentachlorobiphenyl	-	-	-	-	-	-
2,2',3,3',4,4'-Hexachlorobiphenyl	-	-	-	-	-	-
2,2',3,4,4',5-Hexachlorobiphenyl	-	-	-	-	-	-
2,2',3,4,5,5'-Hexachlorobiphenyl	11 D	6.8 D	3.1 D	9.1 D	5.6 D	3.3 D
2,2',3,4',5',6-Hexachlorobiphenyl	-	-	-	-	-	-
2,2',3,5,5',6-Hexachlorobiphenyl	<3.2 D	<4.6 D	<2.0 D	<5.2 D	<4.8 D	<2.1 D
2,2',4,4',5,5'-Hexachlorobiphenyl	45 DJ	24 D	13 D	33 D	19 D	14 D
2,3,3',4,4',5-Hexachlorobiphenyl	-	-	-	-	-	-
2,3,3',4,4',5'-Hexachlorobiphenyl	-	-	-	-	-	-
2,3,3',4,4',6-Hexachlorobiphenyl	-	-	-	-	-	-
2,3',4,4',5,5'-Hexachlorobiphenyl	-	-	-	-	-	-
2,3',4,4',5',6-Hexachlorobiphenyl	-	-	-	-	-	-
3,3',4,4',5,5'-Hexachlorobiphenyl	-	-	-	-	-	-
2,2',3,3',4,4',5-Heptachlorobiphenyl	21 D	11 D	5.3 D	16 D	8.2 D	5.6 D
2,2',3,3',4,5',6-Heptachlorobiphenyl	-	-	-	-	-	-
2,2',3,4,4',5,5'-Heptachlorobiphenyl	37 D	13 DJ	6 DJ	18 DJ	10 DJ	6.7 DJ
2,2',3,4,4',5',6-Heptachlorobiphenyl	-	-	-	-	-	-
2,2',3,4,4',6,6'-Heptachlorobiphenyl	-	-	-	-	-	-
2,2',3,4',5,5',6-Heptachlorobiphenyl	26 DJ	13 D	6.7 D	19 D	12 DJ	7.5 DJ
2,3,3',4,4',5,5'-Heptachlorobiphenyl	-	-	-	-	-	-
2,2',3,3',4,4',5,5'-Octachlorobiphenyl	-	-	-	-	-	-
2,2',3,3',4,4',5,6-Octachlorobiphenyl	-	-	-	-	-	-

TABLE 7

POLYCHLORINATED BIPHENYLS (CONGENERS) SOLID SAMPLE DATA SUMMARY
DEMONSTRATION TESTING AND FULL-SCALE OPERATION OF THE BIOGENESIS SEDIMENT DECONTAMINATION PROCESS
KEASBEY, NEW JERSEY
 (Page 54 of 78)

Field Sample Identification	WS-060406-1300	RS-100406-1525	TS-100406-1615	WS-100406-1630	RS-120406-1815	TS-120406-1835
Sediment Source	Arthur Kill	Arthur Kill	Arthur Kill	Arthur Kill	Arthur Kill	Arthur Kill
Location Identification	WS	RS	TS	WS	RS	TS
Date Collected	4/6/06	4/10/06	4/10/06	4/10/06	4/12/06	4/12/06
Matrix	Solid	Solid	Solid	Solid	Solid	Solid
Analyte/Methods (Units)						
Polychlorinated Biphenyls/SW8082 (µg/kg)						
Individual Congeners (continued)						
2,2',3,3',4,5,5',6'-Octachlorobiphenyl	-	-	-	-	-	-
2,2',3,3',4,5,6,6'-Octachlorobiphenyl	-	-	-	-	-	-
2,2',3,3',5,5',6,6'-Octachlorobiphenyl	-	-	-	-	-	-
2,2',3,3',4,4',5,5',6-Nonachlorobiphenyl	12 D	5.5 D	2.4 D	8.6 D	4.1 TD	2.6 D
2,2',3,3',4,4',5,6,6'-Nonachlorobiphenyl	-	-	-	-	-	-

µg/kg micrograms per kilogram.

Bold Bolded result indicates positively identified compound.

- Not analyzed.

B Analyte detected in an associated blank.

D Sample dilution required for analysis; reported values reflect the dilution.

J Data are estimated due to associated quality control data.

T Analyte was positively identified but the reported concentration is estimated; reported concentration is less than the reporting limit, but greater than the method detection limit.

TABLE 7

POLYCHLORINATED BIPHENYLS (CONGENERS) SOLID SAMPLE DATA SUMMARY
DEMONSTRATION TESTING AND FULL-SCALE OPERATION OF THE BIOGENESIS SEDIMENT DECONTAMINATION PROCESS
KEASBEY, NEW JERSEY
 (Page 55 of 78)

Field Sample Identification	WS-120406-1840	RS-170406-1725	TS-170406-1745	WS-170406-1745	PSS-200406-1600	RS-200406-1615
Sediment Source	Arthur Kill	Arthur Kill	Arthur Kill	Arthur Kill	Arthur Kill	Arthur Kill
Location Identification	WS	RS	TS	WS	PSS	RS
Date Collected	4/12/06	4/17/06	4/17/06	4/17/06	4/20/06	4/20/06
Matrix	Solid	Solid	Solid	Solid	Solid	Solid
Analyte/Methods (Units)						
Polychlorinated Biphenyls/SW8082 (µg/kg)						
Individual Congeners						
2-Chlorobiphenyl	150 D	85 DJB	19 TDJB	100 DJB	22 TDJB	120 DJ
4-Chlorobiphenyl	-	-	-	-	-	-
2,3-Dichlorobiphenyl	5.2 DJ	3.5 TDJB	<2.4 D	15 DB	<5.6 D	13 D
2,4'-Dichlorobiphenyl	-	-	-	-	-	-
4,4'-Dichlorobiphenyl	-	-	-	-	-	-
2,2',5-Trichlorobiphenyl	90 D	47 D	25 D	110 D	36 D	49 D
2,4,4'-Trichlorobiphenyl	-	-	-	-	-	-
2,4,5-Trichlorobiphenyl	98 DJ	46 D	24 D	100 D	37 D	59 D
2,4',5-Trichlorobiphenyl	-	-	-	-	-	-
3,4,4'-Trichlorobiphenyl	-	-	-	-	-	-
2,2',3,5'-Tetrachlorobiphenyl	-	-	-	-	-	-
2,2',4,5'-Tetrachlorobiphenyl	-	-	-	-	-	-
2,2',5,5'-Tetrachlorobiphenyl	76 DJ	40 DJ	20 DJ	89 DJ	29 DJ	43 DJ
2,3',4,4'-Tetrachlorobiphenyl	95 D	49 D	24 D	100 D	36 D	51 D
2,3',4',5-Tetrachlorobiphenyl	-	-	-	-	-	-
2,4,4',5-Tetrachlorobiphenyl	-	-	-	-	-	-
3,3',4,4'-Tetrachlorobiphenyl	-	-	-	-	-	-
3,4,4',5-Tetrachlorobiphenyl	-	-	-	-	-	-
2,2',3,4',5-Pentachlorobiphenyl	-	-	-	-	-	-
2,2',3,4,5'-Pentachlorobiphenyl	21 DJ	10 DJ	5.5 DJ	25 DJ	8.2 DJ	<7.1 D
2,2',4,4',5-Pentachlorobiphenyl	-	-	-	-	-	-
2,2',4,5,5'-Pentachlorobiphenyl	<4.8 D	32 D	17 D	70 D	25 D	34 D
2,3,3',4,4'-Pentachlorobiphenyl	-	-	-	-	-	-
2,3,3',4',6-Pentachlorobiphenyl	66 D	34 D	17 D	73 D	25 D	36 D
2,3',3,5,6-Pentachlorobiphenyl	-	-	-	-	-	-
2,3,4,4',5-Pentachlorobiphenyl	-	-	-	-	-	-

TABLE 7

POLYCHLORINATED BIPHENYLS (CONGENERS) SOLID SAMPLE DATA SUMMARY
DEMONSTRATION TESTING AND FULL-SCALE OPERATION OF THE BIOGENESIS SEDIMENT DECONTAMINATION PROCESS
KEASBEY, NEW JERSEY
 (Page 56 of 78)

Field Sample Identification	WS-120406-1840	RS-170406-1725	TS-170406-1745	WS-170406-1745	PSS-200406-1600	RS-200406-1615
Sediment Source	Arthur Kill	Arthur Kill	Arthur Kill	Arthur Kill	Arthur Kill	Arthur Kill
Location Identification	WS	RS	TS	WS	PSS	RS
Date Collected	4/12/06	4/17/06	4/17/06	4/17/06	4/20/06	4/20/06
Matrix	Solid	Solid	Solid	Solid	Solid	Solid
Analyte/Methods (Units)						
Polychlorinated Biphenyls/SW8082 (µg/kg)						
Individual Congeners (continued)						
2',3,4,4',5-Pentachlorobiphenyl	-	-	-	-	-	-
2,3',4,4',5-Pentachlorobiphenyl	-	-	-	-	-	-
2,3,4,4',6-Pentachlorobiphenyl	-	-	-	-	-	-
2,3',4,4',6-Pentachlorobiphenyl	-	-	-	-	-	-
3,3',4,4',5-Pentachlorobiphenyl	-	-	-	-	-	-
2,2',3,3',4,4'-Hexachlorobiphenyl	-	-	-	-	-	-
2,2',3,4,4',5-Hexachlorobiphenyl	-	-	-	-	-	-
2,2',3,4,5,5'-Hexachlorobiphenyl	11 D	6.4 D	2.6 DJ	13 D	4.8 TD	7.6 D
2,2',3,4',5',6-Hexachlorobiphenyl	-	-	-	-	-	-
2,2',3,5,5',6-Hexachlorobiphenyl	<4.8 D	<5.6 D	<2.4 D	<6.0 D	<5.6 D	<7.1 D
2,2',4,4',5,5'-Hexachlorobiphenyl	41 D	<5.6 D	<2.4 D	49 D	17 D	24 DJ
2,3,3',4,4',5-Hexachlorobiphenyl	-	-	-	-	-	-
2,3,3',4,4',5'-Hexachlorobiphenyl	-	-	-	-	-	-
2,3,3',4,4',6-Hexachlorobiphenyl	-	-	-	-	-	-
2,3',4,4',5,5'-Hexachlorobiphenyl	-	-	-	-	-	-
2,3',4,4',5',6-Hexachlorobiphenyl	-	-	-	-	-	-
3,3',4,4',5,5'-Hexachlorobiphenyl	-	-	-	-	-	-
2,2',3,3',4,4',5-Heptachlorobiphenyl	20 D	9.8 D	<2.4 D	21 D	7 D	11 D
2,2',3,3',4,5',6-Heptachlorobiphenyl	-	-	-	-	-	-
2,2',3,4,4',5,5'-Heptachlorobiphenyl	23 DJ	12 DJ	6.2 DJ	36 D	9.1 DJ	13 DJ
2,2',3,4,4',5',6-Heptachlorobiphenyl	-	-	-	-	-	-
2,2',3,4,4',6,6'-Heptachlorobiphenyl	-	-	-	-	-	-
2,2',3,4',5,5',6-Heptachlorobiphenyl	24 DJ	13 D	6.4 D	27 D	9.4 D	14 DJ
2,3,3',4,4',5,5'-Heptachlorobiphenyl	-	-	-	-	-	-
2,2',3,3',4,4',5,5'-Octachlorobiphenyl	-	-	-	-	-	-
2,2',3,3',4,4',5,6-Octachlorobiphenyl	-	-	-	-	-	-

TABLE 7

POLYCHLORINATED BIPHENYLS (CONGENERS) SOLID SAMPLE DATA SUMMARY
DEMONSTRATION TESTING AND FULL-SCALE OPERATION OF THE BIOGENESIS SEDIMENT DECONTAMINATION PROCESS
KEASBEY, NEW JERSEY
 (Page 57 of 78)

Field Sample Identification	WS-120406-1840	RS-170406-1725	TS-170406-1745	WS-170406-1745	PSS-200406-1600	RS-200406-1615
Sediment Source	Arthur Kill	Arthur Kill	Arthur Kill	Arthur Kill	Arthur Kill	Arthur Kill
Location Identification	WS	RS	TS	WS	PSS	RS
Date Collected	4/12/06	4/17/06	4/17/06	4/17/06	4/20/06	4/20/06
Matrix	Solid	Solid	Solid	Solid	Solid	Solid
Analyte/Methods (Units)						
Polychlorinated Biphenyls/SW8082 (µg/kg)						
Individual Congeners (continued)						
2,2',3,3',4,5,5',6'-Octachlorobiphenyl	-	-	-	-	-	-
2,2,3,3,4,5,6,6-Octachlorobiphenyl	-	-	-	-	-	-
2,2',3,3',5,5',6,6'-Octachlorobiphenyl	-	-	-	-	-	-
2,2',3,3',4,4',5,5',6-Nonachlorobiphenyl	10 D	5.3 TD	2.8 D	12 D	4.1 TD	6.2 TD
2,2',3,3',4,4',5,6,6'-Nonachlorobiphenyl	-	-	-	-	-	-

µg/kg micrograms per kilogram.

Bold Bolded result indicates positively identified compound.

- Not analyzed.

B Analyte detected in an associated blank.

D Sample dilution required for analysis; reported values reflect the dilution.

J Data are estimated due to associated quality control data.

T Analyte was positively identified but the reported concentration is estimated; reported concentration is less than the reporting limit, but greater than the method detection limit.

TABLE 7

POLYCHLORINATED BIPHENYLS (CONGENERS) SOLID SAMPLE DATA SUMMARY
DEMONSTRATION TESTING AND FULL-SCALE OPERATION OF THE BIOGENESIS SEDIMENT DECONTAMINATION PROCESS
KEASBEY, NEW JERSEY
 (Page 58 of 78)

Field Sample Identification	TS-200406-1635	WS-200406-1640	RS-250406-1815	TS-250406-1835	WS-250406-1840	RS-270406-1715
Sediment Source	Arthur Kill	Arthur Kill	Arthur Kill	Arthur Kill	Arthur Kill	Arthur Kill
Location Identification	TS	WS	RS	TS	WS	RS
Date Collected	4/20/06	4/20/06	4/25/06	4/25/06	4/25/06	4/27/06
Matrix	Solid	Solid	Solid	Solid	Solid	Solid
Analyte/Methods (Units)						
Polychlorinated Biphenyls/SW8082 (µg/kg)						
Individual Congeners						
2-Chlorobiphenyl	92 D	140 D	110 DJB	130 DB	170 DJB	99 DJB
4-Chlorobiphenyl	-	-	-	-	-	-
2,3-Dichlorobiphenyl	<2.4 D	10 D	<5.5 D	<2.5 D	7.8 DJ	<5.0 D
2,4'-Dichlorobiphenyl	-	-	-	-	-	-
4,4'-Dichlorobiphenyl	-	-	-	-	-	-
2,2',5-Trichlorobiphenyl	30 D	92 D	52 D	33 D	110 D	48 D
2,4,4'-Trichlorobiphenyl	-	-	-	-	-	-
2,4,5-Trichlorobiphenyl	27 D	87 D	49 DJ	29 DJ	100 DJ	47 DJ
2,4',5-Trichlorobiphenyl	-	-	-	-	-	-
3,4,4'-Trichlorobiphenyl	-	-	-	-	-	-
2,2',3,5'-Tetrachlorobiphenyl	-	-	-	-	-	-
2,2',4,5'-Tetrachlorobiphenyl	-	-	-	-	-	-
2,2',5,5'-Tetrachlorobiphenyl	21 DJ	69 DJ	41 DJ	25 DJ	89 DJ	42 DJ
2,3',4,4'-Tetrachlorobiphenyl	25 D	85 D	50 D	31 D	110 D	51 D
2,3',4',5-Tetrachlorobiphenyl	-	-	-	-	-	-
2,4,4',5-Tetrachlorobiphenyl	-	-	-	-	-	-
3,3',4,4'-Tetrachlorobiphenyl	-	-	-	-	-	-
3,4,4',5-Tetrachlorobiphenyl	-	-	-	-	-	-
2,2',3,4',5-Pentachlorobiphenyl	-	-	-	-	-	-
2,2',3,4,5'-Pentachlorobiphenyl	<2.4 D	<6.1 D	13 DJ	6.7 DJ	23 DJ	12 DJ
2,2',4,4',5-Pentachlorobiphenyl	-	-	-	-	-	-
2,2',4,5,5'-Pentachlorobiphenyl	<2.4 D	63 D	37 D	<2.5 D	<5.8 D	39 D
2,3,3',4,4'-Pentachlorobiphenyl	-	-	-	-	-	-
2,3,3',4',6-Pentachlorobiphenyl	18 D	59 D	36 D	22 D	80 D	35 D
2,3',3,5,6-Pentachlorobiphenyl	-	-	-	-	-	-
2,3,4,4',5-Pentachlorobiphenyl	-	-	-	-	-	-

TABLE 7

POLYCHLORINATED BIPHENYLS (CONGENERS) SOLID SAMPLE DATA SUMMARY
DEMONSTRATION TESTING AND FULL-SCALE OPERATION OF THE BIOGENESIS SEDIMENT DECONTAMINATION PROCESS
KEASBEY, NEW JERSEY
 (Page 59 of 78)

Field Sample Identification	TS-200406-1635	WS-200406-1640	RS-250406-1815	TS-250406-1835	WS-250406-1840	RS-270406-1715
Sediment Source	Arthur Kill	Arthur Kill	Arthur Kill	Arthur Kill	Arthur Kill	Arthur Kill
Location Identification	TS	WS	RS	TS	WS	RS
Date Collected	4/20/06	4/20/06	4/25/06	4/25/06	4/25/06	4/27/06
Matrix	Solid	Solid	Solid	Solid	Solid	Solid
Analyte/Methods (Units)						
Polychlorinated Biphenyls/SW8082 (µg/kg)						
Individual Congeners (continued)						
2',3,4,4',5-Pentachlorobiphenyl	-	-	-	-	-	-
2,3',4,4',5-Pentachlorobiphenyl	-	-	-	-	-	-
2,3,4,4',6-Pentachlorobiphenyl	-	-	-	-	-	-
2,3',4,4',6-Pentachlorobiphenyl	-	-	-	-	-	-
3,3',4,4',5-Pentachlorobiphenyl	-	-	-	-	-	-
2,2',3,3',4,4'-Hexachlorobiphenyl	-	-	-	-	-	-
2,2',3,4,4',5-Hexachlorobiphenyl	-	-	-	-	-	-
2,2',3,4,5,5'-Hexachlorobiphenyl	3.4 D	11 D	6.5 D	3.5 D	13 D	7.2 D
2,2',3,4',5',6-Hexachlorobiphenyl	-	-	-	-	-	-
2,2',3,5,5',6-Hexachlorobiphenyl	<2.4 D	<6.1 D	<5.5 D	<2.5 D	<5.8 D	<5.0 D
2,2',4,4',5,5'-Hexachlorobiphenyl	15 DJ	41 DJ	23 DJ	17 DJ	52 DJ	24 DJ
2,3,3',4,4',5-Hexachlorobiphenyl	-	-	-	-	-	-
2,3,3',4,4',5'-Hexachlorobiphenyl	-	-	-	-	-	-
2,3,3',4,4',6-Hexachlorobiphenyl	-	-	-	-	-	-
2,3',4,4',5,5'-Hexachlorobiphenyl	-	-	-	-	-	-
2,3',4,4',5',6-Hexachlorobiphenyl	-	-	-	-	-	-
3,3',4,4',5,5'-Hexachlorobiphenyl	-	-	-	-	-	-
2,2',3,3',4,4',5-Heptachlorobiphenyl	4.8 D	17 D	10 D	5.9 D	23 D	11 D
2,2',3,3',4,5',6-Heptachlorobiphenyl	-	-	-	-	-	-
2,2',3,4,4',5,5'-Heptachlorobiphenyl	5.7 DJ	20 DJ	13 DJ	6.9 DJ	28 DJ	13 DJ
2,2',3,4,4',5',6-Heptachlorobiphenyl	-	-	-	-	-	-
2,2',3,4,4',6,6'-Heptachlorobiphenyl	-	-	-	-	-	-
2,2',3,4',5,5',6-Heptachlorobiphenyl	7.2 DJ	23 DJ	13 DJ	7.3 DJ	28 DJ	13 DJ
2,3,3',4,4',5,5'-Heptachlorobiphenyl	-	-	-	-	-	-
2,2',3,3',4,4',5,5'-Octachlorobiphenyl	-	-	-	-	-	-
2,2',3,3',4,4',5,6-Octachlorobiphenyl	-	-	-	-	-	-

TABLE 7

POLYCHLORINATED BIPHENYLS (CONGENERS) SOLID SAMPLE DATA SUMMARY
DEMONSTRATION TESTING AND FULL-SCALE OPERATION OF THE BIOGENESIS SEDIMENT DECONTAMINATION PROCESS
KEASBEY, NEW JERSEY
 (Page 60 of 78)

Field Sample Identification	TS-200406-1635	WS-200406-1640	RS-250406-1815	TS-250406-1835	WS-250406-1840	RS-270406-1715
Sediment Source	Arthur Kill	Arthur Kill	Arthur Kill	Arthur Kill	Arthur Kill	Arthur Kill
Location Identification	TS	WS	RS	TS	WS	RS
Date Collected	4/20/06	4/20/06	4/25/06	4/25/06	4/25/06	4/27/06
Matrix	Solid	Solid	Solid	Solid	Solid	Solid
Analyte/Methods (Units)						
Polychlorinated Biphenyls/SW8082 (µg/kg)						
Individual Congeners (continued)						
2,2',3,3',4,5,5',6'-Octachlorobiphenyl	-	-	-	-	-	-
2,2,3,3,4,5,6,6-Octachlorobiphenyl	-	-	-	-	-	-
2,2',3,3',5,5',6,6'-Octachlorobiphenyl	-	-	-	-	-	-
2,2',3,3',4,4',5,5',6-Nonachlorobiphenyl	2.3 TD	10 D	5.8 D	4 D	15 D	6.1 D
2,2',3,3',4,4',5,6,6'-Nonachlorobiphenyl	-	-	-	-	-	-

µg/kg micrograms per kilogram.

Bold Bolded result indicates positively identified compound.

- Not analyzed.

B Analyte detected in an associated blank.

D Sample dilution required for analysis; reported values reflect the dilution.

J Data are estimated due to associated quality control data.

T Analyte was positively identified but the reported concentration is estimated; reported concentration is less than the reporting limit, but greater than the method detection limit.

TABLE 7

POLYCHLORINATED BIPHENYLS (CONGENERS) SOLID SAMPLE DATA SUMMARY
DEMONSTRATION TESTING AND FULL-SCALE OPERATION OF THE BIOGENESIS SEDIMENT DECONTAMINATION PROCESS
KEASBEY, NEW JERSEY
 (Page 61 of 78)

Field Sample Identification	TS-270406-1735	WS-270406-1740	PSS-010506-1600	RS-010506-1615	TS3-010506-1630	TS-010506-1635
Sediment Source	Arthur Kill	Arthur Kill	Lower Passaic River	Lower Passaic River	Lower Passaic River	Lower Passaic River
Location Identification	TS	WS	PSS	RS	TS3	TS
Date Collected	4/27/06	4/27/06	5/1/06	5/1/06	5/1/06	5/1/06
Matrix	Solid	Solid	Solid	Solid	Solid	Solid
Analyte/Methods (Units)						
Polychlorinated Biphenyls/SW8082 (µg/kg)						
Individual Congeners						
2-Chlorobiphenyl	86 DJB	140 DJB	52 TDJB	61 TDB	29 DJB	4.9 TDJB
4-Chlorobiphenyl	-	-	-	-	-	-
2,3-Dichlorobiphenyl	<2.6 D	17 D	1.4 TDJ	1.4 TDJ	2.3 TDJ	2 TDJ
2,4'-Dichlorobiphenyl	-	-	-	-	-	-
4,4'-Dichlorobiphenyl	-	-	-	-	-	-
2,2',5-Trichlorobiphenyl	42 D	140 D	62 D	56 D	52 D	64 D
2,4,4'-Trichlorobiphenyl	-	-	-	-	-	-
2,4,5-Trichlorobiphenyl	40 DJ	120 DJ	59 D	59 D	56 D	72 D
2,4',5-Trichlorobiphenyl	-	-	-	-	-	-
3,4,4'-Trichlorobiphenyl	-	-	-	-	-	-
2,2',3,5'-Tetrachlorobiphenyl	-	-	-	-	-	-
2,2',4,5'-Tetrachlorobiphenyl	-	-	-	-	-	-
2,2',5,5'-Tetrachlorobiphenyl	31 DJ	110 DJ	54 D	50 D	49 D	59 D
2,3',4,4'-Tetrachlorobiphenyl	40 D	130 D	51 D	46 D	43 D	54 D
2,3',4',5-Tetrachlorobiphenyl	-	-	-	-	-	-
2,4,4',5-Tetrachlorobiphenyl	-	-	-	-	-	-
3,3',4,4'-Tetrachlorobiphenyl	-	-	-	-	-	-
3,4,4',5-Tetrachlorobiphenyl	-	-	-	-	-	-
2,2',3,4',5-Pentachlorobiphenyl	-	-	-	-	-	-
2,2',3,4,5'-Pentachlorobiphenyl	8.4 DJ	30 DJ	12 DJ	12 DJ	10 DJ	12 DJ
2,2',4,4',5-Pentachlorobiphenyl	-	-	-	-	-	-
2,2',4,5,5'-Pentachlorobiphenyl	21 DJ	94 D	34 D	30 D	25 D	34 D
2,3,3',4,4'-Pentachlorobiphenyl	-	-	-	-	-	-
2,3,3',4',6-Pentachlorobiphenyl	29 D	91 D	43 D	39 D	35 D	44 D
2,3',3,5,6-Pentachlorobiphenyl	-	-	-	-	-	-
2,3,4,4',5-Pentachlorobiphenyl	-	-	-	-	-	-

TABLE 7

POLYCHLORINATED BIPHENYLS (CONGENERS) SOLID SAMPLE DATA SUMMARY
DEMONSTRATION TESTING AND FULL-SCALE OPERATION OF THE BIOGENESIS SEDIMENT DECONTAMINATION PROCESS
KEASBEY, NEW JERSEY
 (Page 62 of 78)

Field Sample Identification	TS-270406-1735	WS-270406-1740	PSS-010506-1600	RS-010506-1615	TS3-010506-1630	TS-010506-1635
Sediment Source	Arthur Kill	Arthur Kill	Lower Passaic River	Lower Passaic River	Lower Passaic River	Lower Passaic River
Location Identification	TS	WS	PSS	RS	TS3	TS
Date Collected	4/27/06	4/27/06	5/1/06	5/1/06	5/1/06	5/1/06
Matrix	Solid	Solid	Solid	Solid	Solid	Solid
Analyte/Methods (Units)						
Polychlorinated Biphenyls/SW8082 (µg/kg)						
Individual Congeners (continued)						
2',3,4,4',5-Pentachlorobiphenyl	-	-	-	-	-	-
2,3',4,4',5-Pentachlorobiphenyl	-	-	-	-	-	-
2,3,4,4',6-Pentachlorobiphenyl	-	-	-	-	-	-
2,3',4,4',6-Pentachlorobiphenyl	-	-	-	-	-	-
3,3',4,4',5-Pentachlorobiphenyl	-	-	-	-	-	-
2,2',3,3',4,4'-Hexachlorobiphenyl	-	-	-	-	-	-
2,2',3,4,4',5-Hexachlorobiphenyl	-	-	-	-	-	-
2,2',3,4,5,5'-Hexachlorobiphenyl	4.7 D	16 D	11 D	9.4 D	7.4 D	9 D
2,2',3,4',5',6-Hexachlorobiphenyl	-	-	-	-	-	-
2,2',3,5,5',6-Hexachlorobiphenyl	<2.6 D	<6.8 D	<8.4 D	<7.2 D	<2.7 D	<2.7 D
2,2',4,4',5,5'-Hexachlorobiphenyl	21 DJ	60 DJ	34 D	28 D	24 D	30 D
2,3,3',4,4',5-Hexachlorobiphenyl	-	-	-	-	-	-
2,3,3',4,4',5'-Hexachlorobiphenyl	-	-	-	-	-	-
2,3,3',4,4',6-Hexachlorobiphenyl	-	-	-	-	-	-
2,3',4,4',5,5'-Hexachlorobiphenyl	-	-	-	-	-	-
2,3',4,4',5',6-Hexachlorobiphenyl	-	-	-	-	-	-
3,3',4,4',5,5'-Hexachlorobiphenyl	-	-	-	-	-	-
2,2',3,3',4,4',5-Heptachlorobiphenyl	8.1 D	27 D	16 D	13 D	12 D	14 D
2,2',3,3',4,5',6-Heptachlorobiphenyl	-	-	-	-	-	-
2,2',3,4,4',5,5'-Heptachlorobiphenyl	9.4 DJ	32 DJ	21 DJ	16 DJ	19 D	24 D
2,2',3,4,4',5',6-Heptachlorobiphenyl	-	-	-	-	-	-
2,2',3,4,4',6,6'-Heptachlorobiphenyl	-	-	-	-	-	-
2,2',3,4',5,5',6-Heptachlorobiphenyl	11 DJ	34 DJ	20 D	17 D	13 D	17 D
2,3,3',4,4',5,5'-Heptachlorobiphenyl	-	-	-	-	-	-
2,2',3,3',4,4',5,5'-Octachlorobiphenyl	-	-	-	-	-	-
2,2',3,3',4,4',5,6-Octachlorobiphenyl	-	-	-	-	-	-

TABLE 7

POLYCHLORINATED BIPHENYLS (CONGENERS) SOLID SAMPLE DATA SUMMARY
DEMONSTRATION TESTING AND FULL-SCALE OPERATION OF THE BIOGENESIS SEDIMENT DECONTAMINATION PROCESS
KEASBEY, NEW JERSEY
 (Page 63 of 78)

Field Sample Identification	TS-270406-1735	WS-270406-1740	PSS-010506-1600	RS-010506-1615	TS3-010506-1630	TS-010506-1635
Sediment Source	Arthur Kill	Arthur Kill	Lower Passaic River	Lower Passaic River	Lower Passaic River	Lower Passaic River
Location Identification	TS	WS	PSS	RS	TS3	TS
Date Collected	4/27/06	4/27/06	5/1/06	5/1/06	5/1/06	5/1/06
Matrix	Solid	Solid	Solid	Solid	Solid	Solid
Analyte/Methods (Units)						
Polychlorinated Biphenyls/SW8082 (µg/kg)						
Individual Congeners (continued)						
2,2',3,3',4,5,5',6'-Octachlorobiphenyl	-	-	-	-	-	-
2,2,3,3,4,5,6,6-Octachlorobiphenyl	-	-	-	-	-	-
2,2',3,3',5,5',6,6'-Octachlorobiphenyl	-	-	-	-	-	-
2,2',3,3',4,4',5,5',6-Nonachlorobiphenyl	3.9 D	16 D	4.9 TD	4.3 TD	4.2 D	5 D
2,2',3,3',4,4',5,6,6'-Nonachlorobiphenyl	-	-	-	-	-	-

µg/kg micrograms per kilogram.

Bold Bolded result indicates positively identified compound.

- Not analyzed.

B Analyte detected in an associated blank.

D Sample dilution required for analysis; reported values reflect the dilution.

J Data are estimated due to associated quality control data.

T Analyte was positively identified but the reported concentration is estimated; reported concentration is less than the reporting limit, but greater than the method detection limit.

TABLE 7

POLYCHLORINATED BIPHENYLS (CONGENERS) SOLID SAMPLE DATA SUMMARY
DEMONSTRATION TESTING AND FULL-SCALE OPERATION OF THE BIOGENESIS SEDIMENT DECONTAMINATION PROCESS
KEASBEY, NEW JERSEY
 (Page 64 of 78)

Field Sample Identification	WS-010506-1640	PSS-030506-1600	RS-030506-1615	STS-3-030506-1200	STS-4-030506-1400	TS-030506-1635
Sediment Source	Lower Passaic River	Lower Passaic River	Lower Passaic River	Lower Passaic River	Lower Passaic River	Lower Passaic River
Location Identification	WS	PSS	RS	TS	TS	TS
Date Collected	5/1/06	5/3/06	5/3/06	5/3/06	5/3/06	5/3/06
Matrix	Solid	Solid	Solid	Solid	Solid	Solid
Analyte/Methods (Units)						
Polychlorinated Biphenyls/SW8082 (µg/kg)						
Individual Congeners						
2-Chlorobiphenyl	23 TDJB	56 TDJB	49 TDJB	43 DJB	24 TDJB	65 DB
4-Chlorobiphenyl	-	-	-	-	-	-
2,3-Dichlorobiphenyl	<6.3 D	1.2 TDJ	<6.5 D	1.1 TDJ	1.2 TDJ	1.1 TDJ
2,4'-Dichlorobiphenyl	-	-	-	-	-	-
4,4'-Dichlorobiphenyl	-	-	-	-	-	-
2,2',5-Trichlorobiphenyl	140 D	65 D	56 D	51 D	55 D	53 D
2,4,4'-Trichlorobiphenyl	-	-	-	-	-	-
2,4,5-Trichlorobiphenyl	160 D	69 D	57 D	60 D	65 D	59 D
2,4',5-Trichlorobiphenyl	-	-	-	-	-	-
3,4,4'-Trichlorobiphenyl	-	-	-	-	-	-
2,2',3,5'-Tetrachlorobiphenyl	-	-	-	-	-	-
2,2',4,5'-Tetrachlorobiphenyl	-	-	-	-	-	-
2,2',5,5'-Tetrachlorobiphenyl	130 D	58 D	51 D	47 D	48 D	49 D
2,3',4,4'-Tetrachlorobiphenyl	110 D	58 D	47 D	45 D	47 D	45 D
2,3',4',5-Tetrachlorobiphenyl	-	-	-	-	-	-
2,4,4',5-Tetrachlorobiphenyl	-	-	-	-	-	-
3,3',4,4'-Tetrachlorobiphenyl	-	-	-	-	-	-
3,4,4',5-Tetrachlorobiphenyl	-	-	-	-	-	-
2,2',3,4',5-Pentachlorobiphenyl	-	-	-	-	-	-
2,2',3,4,5'-Pentachlorobiphenyl	28 DJ	13 DJ	12 DJ	10 DJ	10 DJ	11 DJ
2,2',4,4',5-Pentachlorobiphenyl	-	-	-	-	-	-
2,2',4,5,5'-Pentachlorobiphenyl	71 D	37 D	31 D	<2.6 D	<2.5 D	28 D
2,3,3',4,4'-Pentachlorobiphenyl	-	-	-	-	-	-
2,3,3',4',6-Pentachlorobiphenyl	96 D	48 D	41 D	39 D	40 D	38 D
2,3',3,5,6-Pentachlorobiphenyl	-	-	-	-	-	-
2,3,4,4',5-Pentachlorobiphenyl	-	-	-	-	-	-

TABLE 7

POLYCHLORINATED BIPHENYLS (CONGENERS) SOLID SAMPLE DATA SUMMARY
DEMONSTRATION TESTING AND FULL-SCALE OPERATION OF THE BIOGENESIS SEDIMENT DECONTAMINATION PROCESS
KEASBEY, NEW JERSEY
 (Page 65 of 78)

Field Sample Identification	WS-010506-1640	PSS-030506-1600	RS-030506-1615	STS-3-030506-1200	STS-4-030506-1400	TS-030506-1635
Sediment Source	Lower Passaic River	Lower Passaic River	Lower Passaic River	Lower Passaic River	Lower Passaic River	Lower Passaic River
Location Identification	WS	PSS	RS	TS	TS	TS
Date Collected	5/1/06	5/3/06	5/3/06	5/3/06	5/3/06	5/3/06
Matrix	Solid	Solid	Solid	Solid	Solid	Solid
Analyte/Methods (Units)						
Polychlorinated Biphenyls/SW8082 (µg/kg)						
Individual Congeners (continued)						
2',3,4,4',5-Pentachlorobiphenyl	-	-	-	-	-	-
2,3',4,4',5-Pentachlorobiphenyl	-	-	-	-	-	-
2,3,4,4',6-Pentachlorobiphenyl	-	-	-	-	-	-
2,3',4,4',6-Pentachlorobiphenyl	-	-	-	-	-	-
3,3',4,4',5-Pentachlorobiphenyl	-	-	-	-	-	-
2,2',3,3',4,4'-Hexachlorobiphenyl	-	-	-	-	-	-
2,2',3,4,4',5-Hexachlorobiphenyl	-	-	-	-	-	-
2,2',3,4,5,5'-Hexachlorobiphenyl	20 D	11 D	9.5 D	8.4 D	8.2 D	8.4 D
2,2',3,4',5',6-Hexachlorobiphenyl	-	-	-	-	-	-
2,2',3,5,5',6-Hexachlorobiphenyl	<6.3 D	<6.4 D	<6.5 D	<2.6 D	<2.5 D	<2.5 D
2,2',4,4',5,5'-Hexachlorobiphenyl	64 D	35 D	29 D	26 D	32 D	26 D
2,3,3',4,4',5-Hexachlorobiphenyl	-	-	-	-	-	-
2,3,3',4,4',5'-Hexachlorobiphenyl	-	-	-	-	-	-
2,3,3',4,4',6-Hexachlorobiphenyl	-	-	-	-	-	-
2,3',4,4',5,5'-Hexachlorobiphenyl	-	-	-	-	-	-
2,3',4,4',5',6-Hexachlorobiphenyl	-	-	-	-	-	-
3,3',4,4',5,5'-Hexachlorobiphenyl	-	-	-	-	-	-
2,2',3,3',4,4',5-Heptachlorobiphenyl	29 D	16 D	14 D	13 D	13 D	12 D
2,2',3,3',4,5',6-Heptachlorobiphenyl	-	-	-	-	-	-
2,2',3,4,4',5,5'-Heptachlorobiphenyl	50 D	27 D	23 D	23 D	23 D	16 DJ
2,2',3,4,4',5',6-Heptachlorobiphenyl	-	-	-	-	-	-
2,2',3,4,4',6,6'-Heptachlorobiphenyl	-	-	-	-	-	-
2,2',3,4',5,5',6-Heptachlorobiphenyl	35 D	21 D	18 D	15 D	16 D	15 D
2,3,3',4,4',5,5'-Heptachlorobiphenyl	-	-	-	-	-	-
2,2',3,3',4,4',5,5'-Octachlorobiphenyl	-	-	-	-	-	-
2,2',3,3',4,4',5,6-Octachlorobiphenyl	-	-	-	-	-	-

TABLE 7

POLYCHLORINATED BIPHENYLS (CONGENERS) SOLID SAMPLE DATA SUMMARY
DEMONSTRATION TESTING AND FULL-SCALE OPERATION OF THE BIOGENESIS SEDIMENT DECONTAMINATION PROCESS
KEASBEY, NEW JERSEY
 (Page 66 of 78)

Field Sample Identification	WS-010506-1640	PSS-030506-1600	RS-030506-1615	STS-3-030506-1200	STS-4-030506-1400	TS-030506-1635
Sediment Source	Lower Passaic River	Lower Passaic River	Lower Passaic River	Lower Passaic River	Lower Passaic River	Lower Passaic River
Location Identification	WS	PSS	RS	TS	TS	TS
Date Collected	5/1/06	5/3/06	5/3/06	5/3/06	5/3/06	5/3/06
Matrix	Solid	Solid	Solid	Solid	Solid	Solid
Analyte/Methods (Units)						
Polychlorinated Biphenyls/SW8082 (µg/kg)						
Individual Congeners (continued)						
2,2',3,3',4,5,5',6'-Octachlorobiphenyl	-	-	-	-	-	-
2,2,3,3,4,5,6,6-Octachlorobiphenyl	-	-	-	-	-	-
2,2',3,3',5,5',6,6'-Octachlorobiphenyl	-	-	-	-	-	-
2,2',3,3',4,4',5,5',6-Nonachlorobiphenyl	12 D	5.2 TD	4.5 TD	4.2 D	4.2 D	4.5 D
2,2',3,3',4,4',5,6,6'-Nonachlorobiphenyl	-	-	-	-	-	-

µg/kg micrograms per kilogram.

Bold Bolded result indicates positively identified compound.

- Not analyzed.

B Analyte detected in an associated blank.

D Sample dilution required for analysis; reported values reflect the dilution.

J Data are estimated due to associated quality control data.

T Analyte was positively identified but the reported concentration is estimated; reported concentration is less than the reporting limit, but greater than the method detection limit.

TABLE 7

POLYCHLORINATED BIPHENYLS (CONGENERS) SOLID SAMPLE DATA SUMMARY
DEMONSTRATION TESTING AND FULL-SCALE OPERATION OF THE BIOGENESIS SEDIMENT DECONTAMINATION PROCESS
KEASBEY, NEW JERSEY
 (Page 67 of 78)

Field Sample Identification	WS-030506-1640	SPC COMP-160506-1700	SPP COMP-170506-1030	MSL01-040107-0905	MSL02-040107-0925	MSL03-040107-0940
Sediment Source	Lower Passaic River	All	All	Lower Passaic River	Lower Passaic River	Lower Passaic River
Location Identification	WS	TSP	TSP	MSL	MSL	MSL
Date Collected	5/3/06	5/16/06	5/17/06	1/4/07	1/4/07	1/4/07
Matrix	Solid	Solid	Solid	Solid	Solid	Solid
Analyte/Methods (Units)						
Polychlorinated Biphenyls/SW8082 (µg/kg)						
Individual Congeners						
2-Chlorobiphenyl	60 TDJB	70 DJ	21 TDJ	6.0 TDJ	13 D	6.0 TDJ
4-Chlorobiphenyl	-	-	-	-	-	-
2,3-Dichlorobiphenyl	1.4 TDJ	5.6 DJ	7.5 D	6.5 BDJ	9.1 BD	1.9 BDJ
2,4'-Dichlorobiphenyl	-	-	-	-	-	-
4,4'-Dichlorobiphenyl	-	-	-	-	-	-
2,2',5-Trichlorobiphenyl	88 D	29 DJ	38 D	11 D	9.9 D	10 D
2,4,4'-Trichlorobiphenyl	-	-	-	-	-	-
2,4,5-Trichlorobiphenyl	93 D	-	-	-	-	-
2,4',5-Trichlorobiphenyl	-	36 D	40 D	19 D	18 D	14 D
3,4,4'-Trichlorobiphenyl	-	-	-	-	-	-
2,2',3,5'-Tetrachlorobiphenyl	-	-	-	-	-	-
2,2',4,5'-Tetrachlorobiphenyl	-	-	-	-	-	-
2,2',5,5'-Tetrachlorobiphenyl	79 D	29 DJ	37 D	14 D	14 D	13 D
2,3',4,4'-Tetrachlorobiphenyl	72 D	34 D	34 D	11 D	9.9 D	7.1 DJ
2,3',4',5-Tetrachlorobiphenyl	-	-	-	-	-	-
2,4,4',5-Tetrachlorobiphenyl	-	-	-	-	-	-
3,3',4,4'-Tetrachlorobiphenyl	-	-	-	-	-	-
3,4,4',5-Tetrachlorobiphenyl	-	-	-	-	-	-
2,2',3,4',5-Pentachlorobiphenyl	-	-	-	-	-	-
2,2',3,4,5'-Pentachlorobiphenyl	16 DJ	8.0 DJ	8.0 DJ	3.3 DJ	3.7 DJ	2.5 DJ
2,2',4,4',5-Pentachlorobiphenyl	-	-	-	-	-	-
2,2',4,5,5'-Pentachlorobiphenyl	<6.5 D	<3.1 D	23 D	12 D	14 D	11 D
2,3,3',4,4'-Pentachlorobiphenyl	-	-	-	-	-	-
2,3,3',4',6-Pentachlorobiphenyl	60 D	25 D	29 D	9.1 DJ	10 DJ	7.8 DJ
2,3',3,5,6-Pentachlorobiphenyl	-	-	-	-	-	-
2,3,4,4',5-Pentachlorobiphenyl	-	-	-	-	-	-

TABLE 7

POLYCHLORINATED BIPHENYLS (CONGENERS) SOLID SAMPLE DATA SUMMARY
DEMONSTRATION TESTING AND FULL-SCALE OPERATION OF THE BIOGENESIS SEDIMENT DECONTAMINATION PROCESS
KEASBEY, NEW JERSEY
 (Page 68 of 78)

Field Sample Identification	WS-030506-1640	SPC COMP-160506-1700	SPP COMP-170506-1030	MSL01-040107-0905	MSL02-040107-0925	MSL03-040107-0940
Sediment Source	Lower Passaic River	All	All	Lower Passaic River	Lower Passaic River	Lower Passaic River
Location Identification	WS	TSP	TSP	MSL	MSL	MSL
Date Collected	5/3/06	5/16/06	5/17/06	1/4/07	1/4/07	1/4/07
Matrix	Solid	Solid	Solid	Solid	Solid	Solid
Analyte/Methods (Units)						
Polychlorinated Biphenyls/SW8082 (µg/kg)						
Individual Congeners (continued)						
2',3,4,4',5-Pentachlorobiphenyl	-	-	-	-	-	-
2,3',4,4',5-Pentachlorobiphenyl	-	-	-	-	-	-
2,3,4,4',6-Pentachlorobiphenyl	-	-	-	-	-	-
2,3',4,4',6-Pentachlorobiphenyl	-	-	-	-	-	-
3,3',4,4',5-Pentachlorobiphenyl	-	-	-	-	-	-
2,2',3,3',4,4'-Hexachlorobiphenyl	-	-	-	-	-	-
2,2',3,4,4',5-Hexachlorobiphenyl	-	-	-	-	-	-
2,2',3,4,5,5'-Hexachlorobiphenyl	14 D	4.1 D	6.2 D	2.4 D	2.4 D	2.1 D
2,2',3,4',5',6-Hexachlorobiphenyl	-	-	-	-	-	-
2,2',3,5,5',6-Hexachlorobiphenyl	<6.5 D	<3.1 D	<2.4 D	<1.1 D	<1.1 D	<1.1 D
2,2',4,4',5,5'-Hexachlorobiphenyl	43 D	15 D	20 D	8.8 DJ	12 D	7.4 DJ
2,3,3',4,4',5-Hexachlorobiphenyl	-	-	-	-	-	-
2,3,3',4,4',5'-Hexachlorobiphenyl	-	-	-	-	-	-
2,3,3',4,4',6-Hexachlorobiphenyl	-	-	-	-	-	-
2,3',4,4',5,5'-Hexachlorobiphenyl	-	-	-	-	-	-
2,3',4,4',5',6-Hexachlorobiphenyl	-	-	-	-	-	-
3,3',4,4',5,5'-Hexachlorobiphenyl	-	-	-	-	-	-
2,2',3,3',4,4',5-Heptachlorobiphenyl	21 D	6.5 D	9.3 D	4.6 D	4.3 D	4.0 D
2,2',3,3',4,5',6-Heptachlorobiphenyl	-	-	-	-	-	-
2,2',3,4,4',5,5'-Heptachlorobiphenyl	27 D	8.3 DJ	16 D	9.0 D	8.3 D	8.3 D
2,2',3,4,4',5',6-Heptachlorobiphenyl	-	-	-	-	-	-
2,2',3,4,4',6,6'-Heptachlorobiphenyl	-	-	-	-	-	-
2,2',3,4',5,5',6-Heptachlorobiphenyl	26 D	8.1 D	11 D	5.3 D	4.7 D	3.4 D
2,3,3',4,4',5,5'-Heptachlorobiphenyl	-	-	-	-	-	-
2,2',3,3',4,4',5,5'-Octachlorobiphenyl	-	-	-	-	-	-
2,2',3,3',4,4',5,6-Octachlorobiphenyl	-	-	-	-	-	-

TABLE 7

POLYCHLORINATED BIPHENYLS (CONGENERS) SOLID SAMPLE DATA SUMMARY
DEMONSTRATION TESTING AND FULL-SCALE OPERATION OF THE BIOGENESIS SEDIMENT DECONTAMINATION PROCESS
KEASBEY, NEW JERSEY
 (Page 69 of 78)

Field Sample Identification	WS-030506-1640	SPC COMP-160506-1700	SPP COMP-170506-1030	MSL01-040107-0905	MSL02-040107-0925	MSL03-040107-0940
Sediment Source	Lower Passaic River	All	All	Lower Passaic River	Lower Passaic River	Lower Passaic River
Location Identification	WS	TSP	TSP	MSL	MSL	MSL
Date Collected	5/3/06	5/16/06	5/17/06	1/4/07	1/4/07	1/4/07
Matrix	Solid	Solid	Solid	Solid	Solid	Solid
Analyte/Methods (Units)						
Polychlorinated Biphenyls/SW8082 (µg/kg)						
Individual Congeners (continued)						
2,2',3,3',4,5,5',6'-Octachlorobiphenyl	-	-	-	-	-	-
2,2,3,3,4,5,6,6-Octachlorobiphenyl	-	-	-	-	-	-
2,2',3,3',5,5',6,6'-Octachlorobiphenyl	-	-	-	-	-	-
2,2',3,3',4,4',5,5',6-Nonachlorobiphenyl	8.7 D	3.5 D	3.2 D	1.8 D	3.0 D	2.0 D
2,2',3,3',4,4',5,6,6'-Nonachlorobiphenyl	-	-	-	-	-	-

µg/kg micrograms per kilogram.

Bold Bolded result indicates positively identified compound.

- Not analyzed.

B Analyte detected in an associated blank.

D Sample dilution required for analysis; reported values reflect the dilution.

J Data are estimated due to associated quality control data.

T Analyte was positively identified but the reported concentration is estimated; reported concentration is less than the reporting limit, but greater than the method detection limit.

TABLE 7

POLYCHLORINATED BIPHENYLS (CONGENERS) SOLID SAMPLE DATA SUMMARY
DEMONSTRATION TESTING AND FULL-SCALE OPERATION OF THE BIOGENESIS SEDIMENT DECONTAMINATION PROCESS
KEASBEY, NEW JERSEY
 (Page 70 of 78)

Field Sample Identification	MSL04-040107-0950	MSL05-040107-1000	MSL06-040107-1015	MSL07-040107-1025	MSL08-040107-1035	MSL09-040107-1045
Sediment Source	Lower Passaic River	Lower Passaic River	Lower Passaic River	Lower Passaic River	Lower Passaic River	Lower Passaic River
Location Identification	MSL	MSL	MSL	MSL	MSL	MSL
Date Collected	1/4/07	1/4/07	1/4/07	1/4/07	1/4/07	1/4/07
Matrix	Solid	Solid	Solid	Solid	Solid	Solid
Analyte/Methods (Units)						
Polychlorinated Biphenyls/SW8082 (µg/kg)						
Individual Congeners						
2-Chlorobiphenyl	7.5 TDJ	5.3 TDJ	8.9 TDJ	5.7 TDJ	5.9 TDJ	5.7 TDJ
4-Chlorobiphenyl	-	-	-	-	-	-
2,3-Dichlorobiphenyl	1.8 BDJ	1.5 BDJ	1.8 BDJ	1.4 BDJ	1.5 BDJ	1.1 BDJ
2,4'-Dichlorobiphenyl	-	-	-	-	-	-
4,4'-Dichlorobiphenyl	-	-	-	-	-	-
2,2',5-Trichlorobiphenyl	8.1 D	8.2 D	10 D	7.6 D	8.5 D	7.8 D
2,4,4'-Trichlorobiphenyl	-	-	-	-	-	-
2,4,5-Trichlorobiphenyl	-	-	-	-	-	-
2,4',5-Trichlorobiphenyl	14 D	13 D	16 D	12 D	14 D	13 D
3,4,4'-Trichlorobiphenyl	-	-	-	-	-	-
2,2',3,5'-Tetrachlorobiphenyl	-	-	-	-	-	-
2,2',4,5'-Tetrachlorobiphenyl	-	-	-	-	-	-
2,2',5,5'-Tetrachlorobiphenyl	11 D	11 D	13 D	9.7 D	11 D	11 D
2,3',4,4'-Tetrachlorobiphenyl	7.6 D	5.6 DJ	7.3 DJ	7.2 D	8.1 D	8.3 D
2,3',4',5-Tetrachlorobiphenyl	-	-	-	-	-	-
2,4,4',5-Tetrachlorobiphenyl	-	-	-	-	-	-
3,3',4,4'-Tetrachlorobiphenyl	-	-	-	-	-	-
3,4,4',5-Tetrachlorobiphenyl	-	-	-	-	-	-
2,2',3,4',5-Pentachlorobiphenyl	-	-	-	-	-	-
2,2',3,4,5'-Pentachlorobiphenyl	2.2 DJ	2.1 DJ	2.5 DJ	2.0 DJ	2.4 DJ	2.9 DJ
2,2',4,4',5-Pentachlorobiphenyl	-	-	-	-	-	-
2,2',4,5,5'-Pentachlorobiphenyl	9.3 D	8.5 D	10 D	8.0 D	9.8 D	9.7 D
2,3,3',4,4'-Pentachlorobiphenyl	-	-	-	-	-	-
2,3,3',4',6-Pentachlorobiphenyl	6.6 DJ	6.3 DJ	7.9 DJ	6.1 DJ	7.0 DJ	8.0 DJ
2,3',3,5,6-Pentachlorobiphenyl	-	-	-	-	-	-
2,3,4,4',5-Pentachlorobiphenyl	-	-	-	-	-	-

TABLE 7

POLYCHLORINATED BIPHENYLS (CONGENERS) SOLID SAMPLE DATA SUMMARY
DEMONSTRATION TESTING AND FULL-SCALE OPERATION OF THE BIOGENESIS SEDIMENT DECONTAMINATION PROCESS
KEASBEY, NEW JERSEY
 (Page 71 of 78)

Field Sample Identification	MSL04-040107-0950	MSL05-040107-1000	MSL06-040107-1015	MSL07-040107-1025	MSL08-040107-1035	MSL09-040107-1045
Sediment Source	Lower Passaic River	Lower Passaic River	Lower Passaic River	Lower Passaic River	Lower Passaic River	Lower Passaic River
Location Identification	MSL	MSL	MSL	MSL	MSL	MSL
Date Collected	1/4/07	1/4/07	1/4/07	1/4/07	1/4/07	1/4/07
Matrix	Solid	Solid	Solid	Solid	Solid	Solid
Analyte/Methods (Units)						
Polychlorinated Biphenyls/SW8082 (µg/kg)						
Individual Congeners (continued)						
2',3,4,4',5-Pentachlorobiphenyl	-	-	-	-	-	-
2,3',4,4',5-Pentachlorobiphenyl	-	-	-	-	-	-
2,3,4,4',6-Pentachlorobiphenyl	-	-	-	-	-	-
2,3',4,4',6-Pentachlorobiphenyl	-	-	-	-	-	-
3,3',4,4',5-Pentachlorobiphenyl	-	-	-	-	-	-
2,2',3,3',4,4'-Hexachlorobiphenyl	-	-	-	-	-	-
2,2',3,4,4',5-Hexachlorobiphenyl	-	-	-	-	-	-
2,2',3,4,5,5'-Hexachlorobiphenyl	1.6 D	1.6 D	2.1 D	1.7 D	1.7 D	2.0 D
2,2',3,4',5',6-Hexachlorobiphenyl	-	-	-	-	-	-
2,2',3,5,5',6-Hexachlorobiphenyl	<1.1 D	<1.0 D	<1.1 D	<1.1 D	<1.1 D	<1.1 D
2,2',4,4',5,5'-Hexachlorobiphenyl	6.0 DJ	5.9 DJ	7.3 DJ	6.1 DJ	6.6 DJ	10 D
2,3,3',4,4',5-Hexachlorobiphenyl	-	-	-	-	-	-
2,3,3',4,4',5'-Hexachlorobiphenyl	-	-	-	-	-	-
2,3,3',4,4',6-Hexachlorobiphenyl	-	-	-	-	-	-
2,3',4,4',5,5'-Hexachlorobiphenyl	-	-	-	-	-	-
2,3',4,4',5',6-Hexachlorobiphenyl	-	-	-	-	-	-
3,3',4,4',5,5'-Hexachlorobiphenyl	-	-	-	-	-	-
2,2',3,3',4,4',5-Heptachlorobiphenyl	3.0 D	2.8 D	2.7 DJ	3.4 D	3.0 D	3.7 D
2,2',3,3',4,5',6-Heptachlorobiphenyl	-	-	-	-	-	-
2,2',3,4,4',5,5'-Heptachlorobiphenyl	6.1 D	5.8 D	5.5 DJ	6.9 D	6.2 D	7.4 D
2,2',3,4,4',5',6-Heptachlorobiphenyl	-	-	-	-	-	-
2,2',3,4,4',6,6'-Heptachlorobiphenyl	-	-	-	-	-	-
2,2',3,4',5,5',6-Heptachlorobiphenyl	3.5 D	3.5 D	3.2 DJ	4.0 D	3.8 D	4.5 D
2,3,3',4,4',5,5'-Heptachlorobiphenyl	-	-	-	-	-	-
2,2',3,3',4,4',5,5'-Octachlorobiphenyl	-	-	-	-	-	-
2,2',3,3',4,4',5,6-Octachlorobiphenyl	-	-	-	-	-	-

TABLE 7

POLYCHLORINATED BIPHENYLS (CONGENERS) SOLID SAMPLE DATA SUMMARY
DEMONSTRATION TESTING AND FULL-SCALE OPERATION OF THE BIOGENESIS SEDIMENT DECONTAMINATION PROCESS
KEASBEY, NEW JERSEY
 (Page 72 of 78)

Field Sample Identification	MSL04-040107-0950	MSL05-040107-1000	MSL06-040107-1015	MSL07-040107-1025	MSL08-040107-1035	MSL09-040107-1045
Sediment Source	Lower Passaic River	Lower Passaic River	Lower Passaic River	Lower Passaic River	Lower Passaic River	Lower Passaic River
Location Identification	MSL	MSL	MSL	MSL	MSL	MSL
Date Collected	1/4/07	1/4/07	1/4/07	1/4/07	1/4/07	1/4/07
Matrix	Solid	Solid	Solid	Solid	Solid	Solid
Analyte/Methods (Units)						
Polychlorinated Biphenyls/SW8082 (µg/kg)						
Individual Congeners (continued)						
2,2',3,3',4,5,5',6'-Octachlorobiphenyl	-	-	-	-	-	-
2,2,3,3,4,5,6,6-Octachlorobiphenyl	-	-	-	-	-	-
2,2',3,3',5,5',6,6'-Octachlorobiphenyl	-	-	-	-	-	-
2,2',3,3',4,4',5,5',6-Nonachlorobiphenyl	1.4 D	1.1 DJ	1.8 D	1.6 D	1.7 D	1.7 D
2,2',3,3',4,4',5,6,6'-Nonachlorobiphenyl	-	-	-	-	-	-

µg/kg micrograms per kilogram.

Bold Bolded result indicates positively identified compound.

- Not analyzed.

B Analyte detected in an associated blank.

D Sample dilution required for analysis; reported values reflect the dilution.

J Data are estimated due to associated quality control data.

T Analyte was positively identified but the reported concentration is estimated; reported concentration is less than the reporting limit, but greater than the method detection limit.

TABLE 7

POLYCHLORINATED BIPHENYLS (CONGENERS) SOLID SAMPLE DATA SUMMARY
DEMONSTRATION TESTING AND FULL-SCALE OPERATION OF THE BIOGENESIS SEDIMENT DECONTAMINATION PROCESS
KEASBEY, NEW JERSEY
 (Page 73 of 78)

Field Sample Identification	MSL10-040107-1055	MSL11-040107-1055	TS1-121908-0800	AD1-121908-0830	AD2-121908-0820	AD3-121908-0840
Sediment Source	Lower Passaic River	Lower Passaic River	Lower Passaic River	None	None	None
Location Identification	MSL	MSL	TS	AD	AD	AD
Date Collected	1/4/07	1/4/07	12/19/08	12/19/08	12/19/08	12/19/08
Matrix	Solid	Solid	Solid	Solid	Solid	Solid
Analyte/Methods (Units)						
Polychlorinated Biphenyls/SW8082 (µg/kg)						
Individual Congeners						
2-Chlorobiphenyl	10 TD	8.5 TDJ	<20	<20	<20	<20
4-Chlorobiphenyl	-	-	-	-	-	-
2,3-Dichlorobiphenyl	1.6 BDJ	1.7 BDJ	<1.0	<1.0	<1.0	<1.0
2,4'-Dichlorobiphenyl	-	-	-	-	-	-
4,4'-Dichlorobiphenyl	-	-	-	-	-	-
2,2',5-Trichlorobiphenyl	8.7 D	9.2 D	11	<1.0	<1.0	<1.0
2,4,4'-Trichlorobiphenyl	-	-	-	-	-	-
2,4,5-Trichlorobiphenyl	-	-	-	-	-	-
2,4',5-Trichlorobiphenyl	14 D	15 D	13	<10	<10	<10
3,4,4'-Trichlorobiphenyl	-	-	-	-	-	-
2,2',3,5'-Tetrachlorobiphenyl	-	-	-	-	-	-
2,2',4,5'-Tetrachlorobiphenyl	-	-	-	-	-	-
2,2',5,5'-Tetrachlorobiphenyl	11 D	12 D	23	<1.0	<1.0	<1.0
2,3',4,4'-Tetrachlorobiphenyl	8.3 D	8.4 D	19	<1.0	<1.0	<1.0
2,3',4',5-Tetrachlorobiphenyl	-	-	-	-	-	-
2,4,4',5-Tetrachlorobiphenyl	-	-	-	-	-	-
3,3',4,4'-Tetrachlorobiphenyl	-	-	-	-	-	-
3,4,4',5-Tetrachlorobiphenyl	-	-	-	-	-	-
2,2',3,4',5-Pentachlorobiphenyl	-	-	-	-	-	-
2,2',3,4,5'-Pentachlorobiphenyl	2.2 DJ	2.3 DJ	7.0 J	<1.0	<1.0	<1.0
2,2',4,4',5-Pentachlorobiphenyl	-	-	-	-	-	-
2,2',4,5,5'-Pentachlorobiphenyl	8.7 D	9.5 D	41 J	<1.0	<1.0	<1.0
2,3,3',4,4'-Pentachlorobiphenyl	-	-	-	-	-	-
2,3,3',4',6-Pentachlorobiphenyl	6.4 DJ	7.0 DJ	<22	<1.0	<1.0	<1.0
2,3',3,5,6-Pentachlorobiphenyl	-	-	-	-	-	-
2,3,4,4',5-Pentachlorobiphenyl	-	-	-	-	-	-

TABLE 7

POLYCHLORINATED BIPHENYLS (CONGENERS) SOLID SAMPLE DATA SUMMARY
DEMONSTRATION TESTING AND FULL-SCALE OPERATION OF THE BIOGENESIS SEDIMENT DECONTAMINATION PROCESS
KEASBEY, NEW JERSEY
 (Page 74 of 78)

Field Sample Identification	MSL10-040107-1055	MSL11-040107-1055	TS1-121908-0800	AD1-121908-0830	AD2-121908-0820	AD3-121908-0840
Sediment Source	Lower Passaic River	Lower Passaic River	Lower Passaic River	None	None	None
Location Identification	MSL	MSL	TS	AD	AD	AD
Date Collected	1/4/07	1/4/07	12/19/08	12/19/08	12/19/08	12/19/08
Matrix	Solid	Solid	Solid	Solid	Solid	Solid
Analyte/Methods (Units)						
Polychlorinated Biphenyls/SW8082 (µg/kg)						
Individual Congeners (continued)						
2',3,4,4',5-Pentachlorobiphenyl	-	-	-	-	-	-
2,3',4,4',5-Pentachlorobiphenyl	-	-	-	-	-	-
2,3,4,4',6-Pentachlorobiphenyl	-	-	-	-	-	-
2,3',4,4',6-Pentachlorobiphenyl	-	-	-	-	-	-
3,3',4,4',5-Pentachlorobiphenyl	-	-	-	-	-	-
2,2',3,3',4,4'-Hexachlorobiphenyl	-	-	-	-	-	-
2,2',3,4,4',5-Hexachlorobiphenyl	-	-	-	-	-	-
2,2',3,4,5,5'-Hexachlorobiphenyl	1.6 D	1.7 D	3.9	<1.0	<1.0	<1.0
2,2',3,4',5',6-Hexachlorobiphenyl	-	-	-	-	-	-
2,2',3,5,5',6-Hexachlorobiphenyl	<1.1 D	<1.1 D	3.8	<1.0	<1.0	<1.0
2,2',4,4',5,5'-Hexachlorobiphenyl	6.1 DJ	8.3 D	18	<1.0	<1.0	<1.0
2,3,3',4,4',5-Hexachlorobiphenyl	-	-	-	-	-	-
2,3,3',4,4',5'-Hexachlorobiphenyl	-	-	-	-	-	-
2,3,3',4,4',6-Hexachlorobiphenyl	-	-	-	-	-	-
2,3',4,4',5,5'-Hexachlorobiphenyl	-	-	-	-	-	-
2,3',4,4',5',6-Hexachlorobiphenyl	-	-	-	-	-	-
3,3',4,4',5,5'-Hexachlorobiphenyl	-	-	-	-	-	-
2,2',3,3',4,4',5-Heptachlorobiphenyl	3.0 D	3.1 D	5.3 J	<1.0	<1.0	<1.0
2,2',3,3',4,5',6-Heptachlorobiphenyl	-	-	-	-	-	-
2,2',3,4,4',5,5'-Heptachlorobiphenyl	6.1 D	4.4 DJ	10	<1.0	<1.0	<1.0
2,2',3,4,4',5',6-Heptachlorobiphenyl	-	-	-	-	-	-
2,2',3,4,4',6,6'-Heptachlorobiphenyl	-	-	-	-	-	-
2,2',3,4',5,5',6-Heptachlorobiphenyl	3.6 D	3.7 D	6.8	<1.0	<1.0	<1.0
2,3,3',4,4',5,5'-Heptachlorobiphenyl	-	-	-	-	-	-
2,2',3,3',4,4',5,5'-Octachlorobiphenyl	-	-	-	-	-	-
2,2',3,3',4,4',5,6-Octachlorobiphenyl	-	-	-	-	-	-

TABLE 7

POLYCHLORINATED BIPHENYLS (CONGENERS) SOLID SAMPLE DATA SUMMARY
DEMONSTRATION TESTING AND FULL-SCALE OPERATION OF THE BIOGENESIS SEDIMENT DECONTAMINATION PROCESS
KEASBEY, NEW JERSEY
 (Page 75 of 78)

Field Sample Identification	MSL10-040107-1055	MSL11-040107-1055	TS1-121908-0800	AD1-121908-0830	AD2-121908-0820	AD3-121908-0840
Sediment Source	Lower Passaic River	Lower Passaic River	Lower Passaic River	None	None	None
Location Identification	MSL	MSL	TS	AD	AD	AD
Date Collected	1/4/07	1/4/07	12/19/08	12/19/08	12/19/08	12/19/08
Matrix	Solid	Solid	Solid	Solid	Solid	Solid
Analyte/Methods (Units)						
Polychlorinated Biphenyls/SW8082 (µg/kg)						
Individual Congeners (continued)						
2,2',3,3',4,5,5',6'-Octachlorobiphenyl	-	-	-	-	-	-
2,2,3,3,4,5,6,6-Octachlorobiphenyl	-	-	-	-	-	-
2,2',3,3',5,5',6,6'-Octachlorobiphenyl	-	-	-	-	-	-
2,2',3,3',4,4',5,5',6-Nonachlorobiphenyl	1.0 TDJ	1.0 TDJ	3.1	<1.0	<1.0	<1.0
2,2',3,3',4,4',5,6,6'-Nonachlorobiphenyl	-	-	-	-	-	-

µg/kg micrograms per kilogram.

Bold Bolded result indicates positively identified compound.

- Not analyzed.

B Analyte detected in an associated blank.

D Sample dilution required for analysis; reported values reflect the dilution.

J Data are estimated due to associated quality control data.

T Analyte was positively identified but the reported concentration is estimated; reported concentration is less than the reporting limit, but greater than the method detection limit.

TABLE 7

POLYCHLORINATED BIPHENYLS (CONGENERS) SOLID SAMPLE DATA SUMMARY
DEMONSTRATION TESTING AND FULL-SCALE OPERATION OF THE BIOGENESIS SEDIMENT DECONTAMINATION PROCESS
KEASBEY, NEW JERSEY
 (Page 76 of 78)

Field Sample Identification		MS1-121908-0850
Sediment Source		Lower Passaic River
Location Identification	Date Collected	MSL
Matrix		Solid
Analyte/Methods (Units)		
Polychlorinated Biphenyls/SW8082 (µg/kg)		
Individual Congeners		
2-Chlorobiphenyl		<20
4-Chlorobiphenyl		-
2,3-Dichlorobiphenyl		<1.0
2,4'-Dichlorobiphenyl		-
4,4'-Dichlorobiphenyl		-
2,2',5-Trichlorobiphenyl		4.1 J
2,4,4'-Trichlorobiphenyl		-
2,4,5-Trichlorobiphenyl		-
2,4',5-Trichlorobiphenyl		5.4 J
3,4,4'-Trichlorobiphenyl		-
2,2',3,5'-Tetrachlorobiphenyl		-
2,2',4,5'-Tetrachlorobiphenyl		-
2,2',5,5'-Tetrachlorobiphenyl		8.1
2,3',4,4'-Tetrachlorobiphenyl		7.8 J
2,3',4',5-Tetrachlorobiphenyl		-
2,4,4',5-Tetrachlorobiphenyl		-
3,3',4,4'-Tetrachlorobiphenyl		-
3,4,4',5-Tetrachlorobiphenyl		-
2,2',3,4',5-Pentachlorobiphenyl		-
2,2',3,4,5'-Pentachlorobiphenyl		3.0 J
2,2',4,4',5-Pentachlorobiphenyl		-
2,2',4,5,5'-Pentachlorobiphenyl		21
2,3,3',4,4'-Pentachlorobiphenyl		-
2,3,3',4',6-Pentachlorobiphenyl		<1.0
2,3',3,5,6-Pentachlorobiphenyl		-
2,3,4,4',5-Pentachlorobiphenyl		-

TABLE 7

POLYCHLORINATED BIPHENYLS (CONGENERS) SOLID SAMPLE DATA SUMMARY
DEMONSTRATION TESTING AND FULL-SCALE OPERATION OF THE BIOGENESIS SEDIMENT DECONTAMINATION PROCESS
KEASBEY, NEW JERSEY
 (Page 77 of 78)

Field Sample Identification	MS1-121908-0850
Sediment Source	Lower Passaic River
Location Identification	MSL
Date Collected	12/19/08
Matrix	Solid
Analyte/Methods (Units)	
Polychlorinated Biphenyls/SW8082 (µg/kg)	
Individual Congeners (continued)	
2',3,4,4',5-Pentachlorobiphenyl	-
2,3',4,4',5-Pentachlorobiphenyl	-
2,3,4,4',6-Pentachlorobiphenyl	-
2,3',4,4',6-Pentachlorobiphenyl	-
3,3',4,4',5-Pentachlorobiphenyl	-
2,2',3,3',4,4'-Hexachlorobiphenyl	-
2,2',3,4,4',5-Hexachlorobiphenyl	-
2,2',3,4,5,5'-Hexachlorobiphenyl	1.7
2,2',3,4',5',6-Hexachlorobiphenyl	-
2,2',3,5,5',6-Hexachlorobiphenyl	1.7
2,2',4,4',5,5'-Hexachlorobiphenyl	7.7
2,3,3',4,4',5-Hexachlorobiphenyl	-
2,3,3',4,4',5'-Hexachlorobiphenyl	-
2,3,3',4,4',6-Hexachlorobiphenyl	-
2,3',4,4',5,5'-Hexachlorobiphenyl	-
2,3',4,4',5',6-Hexachlorobiphenyl	-
3,3',4,4',5,5'-Hexachlorobiphenyl	-
2,2',3,3',4,4',5-Heptachlorobiphenyl	2.8 J
2,2',3,3',4,5',6'-Heptachlorobiphenyl	-
2,2',3,4,4',5,5'-Heptachlorobiphenyl	4.7
2,2',3,4,4',5',6-Heptachlorobiphenyl	-
2,2',3,4,4',6,6'-Heptachlorobiphenyl	-
2,2',3,4',5,5',6-Heptachlorobiphenyl	3.0
2,3,3',4,4',5,5'-Heptachlorobiphenyl	-
2,2',3,3',4,4',5,5'-Octachlorobiphenyl	-
2,2',3,3',4,4',5,6-Octachlorobiphenyl	-

TABLE 7

POLYCHLORINATED BIPHENYLS (CONGENERS) SOLID SAMPLE DATA SUMMARY
DEMONSTRATION TESTING AND FULL-SCALE OPERATION OF THE BIOGENESIS SEDIMENT DECONTAMINATION PROCESS
KEASBEY, NEW JERSEY
 (Page 78 of 78)

Field Sample Identification		MS1-121908-0850
Sediment Source		Lower Passaic River
Location Identification	MSL	
Date Collected	12/19/08	
Matrix	Solid	
Analyte/Methods (Units)		
Polychlorinated Biphenyls/SW8082 (µg/kg)		
Individual Congeners (continued)		
2,2',3,3',4,5,5',6'-Octachlorobiphenyl	-	
2,2,3,3,4,5,6,6-Octachlorobiphenyl	-	
2,2',3,3',5,5',6,6'-Octachlorobiphenyl	-	
2,2',3,3',4,4',5,5',6-Nonachlorobiphenyl	1.3	
2,2',3,3',4,4',5,6,6'-Nonachlorobiphenyl	-	

µg/kg micrograms per kilogram.

Bold Bolded result indicates positively identified compound.

- Not analyzed.

B Analyte detected in an associated blank.

D Sample dilution required for analysis; reported values reflect the dilution.

J Data are estimated due to associated quality control data.

T Analyte was positively identified but the reported concentration is estimated; reported concentration is less than the reporting limit, but greater than the method detection limit.

TABLE 8

DIOXINS/FURANS SOLID SAMPLE DATA SUMMARY
DEMONSTRATION TESTING AND FULL-SCALE OPERATION OF THE BIOGENESIS SEDIMENT DECONTAMINATION PROCESS
KEASBEY, NEW JERSEY
 (Page 1 of 25)

Field Sample Identification	RS-211205-1000	TS-211205-1715	WS1-211205-1800	TS-291205-1100	WS-291205-1110	RS-030106-1600
Sediment Source	Raritan River	Raritan River	Raritan River	Raritan River	Raritan River	Raritan River
Location Identification	RS	TS	WS	TS	WS	RS
Date Collected	12/21/05	12/21/05	12/21/05	12/29/05	12/29/05	1/3/06
Matrix	Solid	Solid	Solid	Solid	Solid	Solid
Analyte/Methods (Units)						
Dioxins/Furans (Picogram/gram)						
1,2,3,4,6,7,8-Heptachlorodibenzo-p-dioxin	150 B	2.7 TB	12 TB	27 B	5.6 TB	170 B
1,2,3,4,6,7,8-Heptachlorodibenzofuran	21 B	0.67 TB	1.8 TB	3.0 TJ	1.1 TJ	23 B
1,2,3,4,7,8,9-Heptachlorodibenzofuran	2.7 TB	<6.9	<16	<16	<7.2	2.4 TJ
1,2,3,4,7,8-Hexachlorodibenzo-p-dioxin	2.2 T	0.17 TJ	<16	<16	<7.2	2.4 TJ
1,2,3,4,7,8-Hexachlorodibenzofuran	7.4 T	0.22 TJ	0.6 TJ	1.0 TJ	0.4 T	4.6 T
1,2,3,6,7,8-Hexachlorodibenzo-p-dioxin	7.1 T	0.11 TJ	<16	1.4 T	0.49 TJ	8.1 T
1,2,3,6,7,8-Hexachlorodibenzofuran	2 T	0.19 T	<16	0.62 T	<7.2	2.7 T
1,2,3,7,8,9-Hexachlorodibenzo-p-dioxin	7.4 TB	0.18 TJUB	0.39 TJUB	1.7 T	0.39 TJ	7.6 TB
1,2,3,7,8,9-Hexachlorodibenzofuran	0.46 TJ	0.13 TJ	<16	<16	<7.2	30 JB
1,2,3,7,8-Pentachlorodibenzo-p-dioxin	1.4 T	0.17 TJ	<16	<16	<7.2	1.7 T
1,2,3,7,8-Pentachlorodibenzofuran	2.4 TB	0.089 TJUB	0.39 TJB	0.46 TJUB	0.086 TJUB	2.4 TB
2,3,4,6,7,8-Hexachlorodibenzofuran	1.5 TJ	0.15 T	<16	<16	<7.2	2.3 TJB
2,3,4,7,8-Pentachlorodibenzofuran	4.3 TB	0.19 TJUB	0.3 TJB	0.63 TJUB	0.35 TJUB	3.6 TB
2,3,7,8-Tetrachlorodibenzo-p-dioxin	1.8 T	<1.4	<3.2	<3.2	<1.4	1.5 TJ
2,3,7,8-Tetrachlorodibenzofuran	4.6	0.33 T	0.96 TJ	1.3 TJ	1.3 TJ	3.9
Octachlorodibenzo-p-dioxin	8700 B	52 B	610 B	1600 B	170 B	9400 B
Octachlorodibenzofuran	31 B	0.81 TJUB	2.4 TJB	4.6 TUB	2.0 TUB	21 TB

Bold Bolded result indicates positively identified compound.
B Analyte detected in an associated blank.
J Data are estimated due to associated quality control data.
T Analyte was positively identified but the reported concentration is estimated; reported concentration is less than the reporting limit, but greater than the method detection limit.
UB Analyte considered not detected based on associated blank data.

TABLE 8

DIOXINS/FURANS SOLID SAMPLE DATA SUMMARY
DEMONSTRATION TESTING AND FULL-SCALE OPERATION OF THE BIOGENESIS SEDIMENT DECONTAMINATION PROCESS
KEASBEY, NEW JERSEY
 (Page 2 of 25)

Field Sample Identification	TS-030106-1645	WS1-030106-1615	WS2-030106-1630	RS-040106-1300	TS-040106-1100	WS-040106-1400
Sediment Source	Raritan River	Raritan River	Raritan River	Raritan River	Raritan River	Raritan River
Location Identification	TS	WS1	WS2	RS	TS	WS
Date Collected	1/3/06	1/3/06	1/3/06	1/4/06	1/4/06	1/4/06
Matrix	Solid	Solid	Solid	Solid	Solid	Solid
Analyte/Methods (Units)						
Dioxins/Furans (Picogram/gram)						
1,2,3,4,6,7,8-Heptachlorodibenzo-p-dioxin	26	28	11 T	170 B	6.1 T	15 T
1,2,3,4,6,7,8-Heptachlorodibenzofuran	4.6 TB	3.9 TB	2.5 TJB	24 B	0.86 TB	2.5 TJB
1,2,3,4,7,8,9-Heptachlorodibenzofuran	0.56 T	0.73 T	<14	4.2 T	<7.3	<16
1,2,3,4,7,8-Hexachlorodibenzo-p-dioxin	0.43 T	<19	<14	3.0 TJ	<7.3	<16
1,2,3,4,7,8-Hexachlorodibenzofuran	2.2 T	0.88 TJ	0.62 TJ	8.7 T	0.49 TJ	0.63 TJ
1,2,3,6,7,8-Hexachlorodibenzo-p-dioxin	1.7 T	1.1 TJ	0.56 T	8.9 T	0.44 TJ	0.79 T
1,2,3,6,7,8-Hexachlorodibenzofuran	0.59 TJ	0.35 TJ	<14	3.5 T	<7.3	<16
1,2,3,7,8,9-Hexachlorodibenzo-p-dioxin	1.5 T	1.0 TJ	0.58 T	10 TB	0.45 T	<16
1,2,3,7,8,9-Hexachlorodibenzofuran	<7.0	<19	<14	1.2 TJB	<7.3	<16
1,2,3,7,8-Pentachlorodibenzo-p-dioxin	0.39 T	<19	0.4 TJ	2.4 TJ	<7.3	<16
1,2,3,7,8-Pentachlorodibenzofuran	0.5 TJ	<19	<14	2.9 TJB	<7.3	<16
2,3,4,6,7,8-Hexachlorodibenzofuran	0.56 T	0.44 T	0.37 T	3.4 TB	<7.3	<16
2,3,4,7,8-Pentachlorodibenzofuran	1.3 T	0.67 TJ	<14	8.3 TB	0.38 T	<16
2,3,7,8-Tetrachlorodibenzo-p-dioxin	0.56 T	<3.7	<2.9	1.8 TJ	<1.5	<3.2
2,3,7,8-Tetrachlorodibenzofuran	1.4 J	2.7 T	1.4 T	7.8 J	1.4 T	0.52 TJ
Octachlorodibenzo-p-dioxin	920 B	1600 B	370 B	9600 B	270 B	730 B
Octachlorodibenzofuran	3.9 TB	5.3 TB	3.4 TB	28 TB	1.4 TB	3.2 TJB

Bold Bolded result indicates positively identified compound.
B Analyte detected in an associated blank.
J Data are estimated due to associated quality control data.
T Analyte was positively identified but the reported concentration is estimated; reported concentration is less than the reporting limit, but greater than the method detection limit.
UB Analyte considered not detected based on associated blank data.

TABLE 8

DIOXINS/FURANS SOLID SAMPLE DATA SUMMARY
DEMONSTRATION TESTING AND FULL-SCALE OPERATION OF THE BIOGENESIS SEDIMENT DECONTAMINATION PROCESS
KEASBEY, NEW JERSEY
 (Page 3 of 25)

Field Sample Identification	RS-050106-1500	TS-050106-1505	WS-050106-1510	RS-060106-1531	TS-060106-1532	WS-060106-1533
Sediment Source	Raritan River	Raritan River	Raritan River	Raritan River	Raritan River	Raritan River
Location Identification	RS	TS	WS	RS	TS	WS
Date Collected	1/5/06	1/5/06	1/5/06	1/6/06	1/6/06	1/6/06
Matrix	Solid	Solid	Solid	Solid	Solid	Solid
Analyte/Methods (Units)						
Dioxins/Furans (Picogram/gram)						
1,2,3,4,6,7,8-Heptachlorodibenzo-p-dioxin	170 B	26	11 T	31 B	9.2 B	12 TB
1,2,3,4,6,7,8-Heptachlorodibenzofuran	23 B	4.3 TB	1.7 TJB	3.8 TJB	1.6 TB	1.8 TJB
1,2,3,4,7,8,9-Heptachlorodibenzofuran	2.3 T	0.55 T	<14	<14	<7.8	<14
1,2,3,4,7,8-Hexachlorodibenzo-p-dioxin	3.0 T	0.47 T	<14	<14	0.31 TJ	<14
1,2,3,4,7,8-Hexachlorodibenzofuran	8.0 T	2.5 T	0.51 TJ	1.1 TJ	0.53 TJ	<14
1,2,3,6,7,8-Hexachlorodibenzo-p-dioxin	6.3 TJ	1.7 TJ	0.68 TJ	1.2 TJ	0.59 TJ	<14
1,2,3,6,7,8-Hexachlorodibenzofuran	2.8 T	0.59 T	<14	0.59 T	0.21 TJ	<14
1,2,3,7,8,9-Hexachlorodibenzo-p-dioxin	7.7 TJB	1.5 T	0.79 T	1.2 TJ	0.76 TJUB	<14
1,2,3,7,8,9-Hexachlorodibenzofuran	0.62 TJUB	<7.3	<14	<14	<7.8	<14
1,2,3,7,8-Pentachlorodibenzo-p-dioxin	1.8 T	0.51 T	<14	<14	0.21 TJ	<14
1,2,3,7,8-Pentachlorodibenzofuran	2.1 TB	0.6 TJ	<14	0.34 T	0.15 TJUB	<14
2,3,4,6,7,8-Hexachlorodibenzofuran	2.4 TB	0.6 T	<14	0.49 TJ	<7.8	<14
2,3,4,7,8-Pentachlorodibenzofuran	4.2 TB	1.8 T	0.34 TJ	0.88 TB	0.6 TB	<14
2,3,7,8-Tetrachlorodibenzo-p-dioxin	2.1 T	0.33 TJ	<2.8	<2.7	<1.6	<2.8
2,3,7,8-Tetrachlorodibenzofuran	4.0	1.9	0.66 TJ	1.7 T	0.49 TJ	0.92 T
Octachlorodibenzo-p-dioxin	9700 B	960 B	570 B	1900 B	400 B	670 B
Octachlorodibenzofuran	22 TB	6.3 TJB	2.7 TB	4.3 TJ	2.3 TB	2.2 TB

- Bold** Bolded result indicates positively identified compound.
B Analyte detected in an associated blank.
J Data are estimated due to associated quality control data.
T Analyte was positively identified but the reported concentration is estimated; reported concentration is less than the reporting limit, but greater than the method detection limit.
UB Analyte considered not detected based on associated blank data.

TABLE 8

DIOXINS/FURANS SOLID SAMPLE DATA SUMMARY
DEMONSTRATION TESTING AND FULL-SCALE OPERATION OF THE BIOGENESIS SEDIMENT DECONTAMINATION PROCESS
KEASBEY, NEW JERSEY
 (Page 4 of 25)

Field Sample Identification	RS-090106-1500	TS-090106-1501	WS-090106-1502	RS-100106-1600	TS-100106-1601	WS-100106-1602
Sediment Source	Raritan River	Raritan River	Raritan River	Raritan River	Raritan River	Raritan River
Location Identification	RS	TS	WS	RS	TS	WS
Date Collected	1/9/06	1/9/06	1/9/06	1/10/06	1/10/06	1/10/06
Matrix	Solid	Solid	Solid	Solid	Solid	Solid
Analyte/Methods (Units)						
Dioxins/Furans (Picogram/gram)						
1,2,3,4,6,7,8-Heptachlorodibenzo-p-dioxin	160	5.6 T	28	160	53 J	17
1,2,3,4,6,7,8-Heptachlorodibenzofuran	27	1.0 TJ	4.1 TJ	24	21	2.8 T
1,2,3,4,7,8,9-Heptachlorodibenzofuran	3.5 T	<7.5	<13	3.1 TJ	4.1 TJ	<12
1,2,3,4,7,8-Hexachlorodibenzo-p-dioxin	<23	<7.5	<13	2.0 TJ	1.7 T	<12
1,2,3,4,7,8-Hexachlorodibenzofuran	11 T	0.61 T	0.98 TJ	7.6 T	9.4	0.55 T
1,2,3,6,7,8-Hexachlorodibenzo-p-dioxin	8.5 T	0.53 T	1.1 T	7.7 T	5.2 T	0.62 TJ
1,2,3,6,7,8-Hexachlorodibenzofuran	4.8 T	0.17 TJ	<13	2.4 T	2.4 T	<12
1,2,3,7,8,9-Hexachlorodibenzo-p-dioxin	8.8 T	0.37 TJ	1.2 TJ	9.5 T	3.9 T	1.8 T
1,2,3,7,8,9-Hexachlorodibenzofuran	1.8 TJ	<7.5	<13	<24	0.38 TJ	<12
1,2,3,7,8-Pentachlorodibenzo-p-dioxin	2.5 TJ	<7.5	<13	2.0 T	1.3 TJ	<12
1,2,3,7,8-Pentachlorodibenzofuran	3.2 TJ	0.22 T	<13	2.7 T	2.3 TJ	0.22 TJ
2,3,4,6,7,8-Hexachlorodibenzofuran	3.4 T	<7.5	<13	2.0 T	4.2 T	<12
2,3,4,7,8-Pentachlorodibenzofuran	5.1 TJ	0.42 TJ	0.56 TJ	4.1 T	5.8 T	<12
2,3,7,8-Tetrachlorodibenzo-p-dioxin	<4.6	0.27 T	<2.6	1.9 T	1.9	<2.4
2,3,7,8-Tetrachlorodibenzofuran	1.4 TJ	0.92 TJ	1.4 T	3.7 TJ	4.4 J	1.1 TJ
Octachlorodibenzo-p-dioxin	9600 B	210 B	1600 B	9300 B	820 JB	910 B
Octachlorodibenzofuran	29 T	0.78 TJ	3.8 T	30 T	26	3.8 T

Bold Bolded result indicates positively identified compound.

B Analyte detected in an associated blank.

J Data are estimated due to associated quality control data.

T Analyte was positively identified but the reported concentration is estimated; reported concentration is less than the reporting limit, but greater than the method detection limit.

UB Analyte considered not detected based on associated blank data.

TABLE 8

DIOXINS/FURANS SOLID SAMPLE DATA SUMMARY
DEMONSTRATION TESTING AND FULL-SCALE OPERATION OF THE BIOGENESIS SEDIMENT DECONTAMINATION PROCESS
KEASBEY, NEW JERSEY
 (Page 5 of 25)

Field Sample Identification	RS-110106-1630	TS-110106-1631	RS-120106-1630	TS-120106-1601	WS-120106-1602	RS-190106-1600
Sediment Source	Raritan River	Raritan River	Raritan River	Raritan River	Raritan River	Lower Passaic River
Location Identification	RS	TS	RS	TS	WS	RS
Date Collected	1/11/06	1/11/06	1/12/06	1/12/06	1/12/06	1/19/06
Matrix	Solid	Solid	Solid	Solid	Solid	Solid
Analyte/Methods (Units)						
Dioxins/Furans (Picogram/gram)						
1,2,3,4,6,7,8-Heptachlorodibenzo-p-dioxin	150 B	30 B	170	79	40	810 UB
1,2,3,4,6,7,8-Heptachlorodibenzofuran	20 B	6.5 TB	25	16	4.8 T	790 B
1,2,3,4,7,8,9-Heptachlorodibenzofuran	2.7 TJ	0.64 T	2.3 T	1.5 T	<16	39 UB
1,2,3,4,7,8-Hexachlorodibenzo-p-dioxin	1.9 T	0.62 T	2.2 TJ	1.5 T	<16	13 T
1,2,3,4,7,8-Hexachlorodibenzofuran	6.9 T	2.5 T	7.5 T	5.4 T	1.9 T	240 UB
1,2,3,6,7,8-Hexachlorodibenzo-p-dioxin	6.3 T	1.8 T	7.4 T	5.1 T	1.3 TJ	59
1,2,3,6,7,8-Hexachlorodibenzofuran	2.0 TJ	0.78 T	2.4 TJ	1.5 TJ	<16	58 UB
1,2,3,7,8,9-Hexachlorodibenzo-p-dioxin	7.2 T	1.3 T	8.2 T	4.9 T	0.75 TJ	44 UB
1,2,3,7,8,9-Hexachlorodibenzofuran	<14	<10	<22	<8.9	<16	<36
1,2,3,7,8-Pentachlorodibenzo-p-dioxin	1.2 TJ	0.48 T	1.5 T	1.1 TJ	<16	11 TJ
1,2,3,7,8-Pentachlorodibenzofuran	2.6 T	0.67 TJ	2.4 T	2.0 T	<16	19 TJ
2,3,4,6,7,8-Hexachlorodibenzofuran	2.1 T	0.81 T	1.9 T	2.8 T	<16	32 T
2,3,4,7,8-Pentachlorodibenzofuran	3.2 T	1.0 TJ	4.4 T	3.9 T	<16	62
2,3,7,8-Tetrachlorodibenzo-p-dioxin	1.3 T	0.48 TJ	1.9 TJ	1.3 T	<3.2	450
2,3,7,8-Tetrachlorodibenzofuran	1.6 TJ	0.49 TJ	8.8	5.1 J	2.0 T	40
Octachlorodibenzo-p-dioxin	8200 B	1300 B	10000 B	2200 B	2500 B	8600 B
Octachlorodibenzofuran	37 B	7.4 TB	43 TB	23 B	7.9 TB	1000 UB

Bold Bolded result indicates positively identified compound.
B Analyte detected in an associated blank.
J Data are estimated due to associated quality control data.
T Analyte was positively identified but the reported concentration is estimated; reported concentration is less than the reporting limit, but greater than the method detection limit.
UB Analyte considered not detected based on associated blank data.

TABLE 8

DIOXINS/FURANS SOLID SAMPLE DATA SUMMARY
DEMONSTRATION TESTING AND FULL-SCALE OPERATION OF THE BIOGENESIS SEDIMENT DECONTAMINATION PROCESS
KEASBEY, NEW JERSEY
 (Page 6 of 25)

Field Sample Identification	TS-190106-1601	WS-190106-1602	RS-240106-1530	TS-240106-1630	RS-270106-1400	TS-270106-1401
Sediment Source	Lower Passaic River	Lower Passaic River	Lower Passaic River	Lower Passaic River	Lower Passaic River	Lower Passaic River
Location Identification	TS	WS	RS	TS	RS	TS
Date Collected	1/19/06	1/19/06	1/24/06	1/24/06	1/27/06	1/27/06
Matrix	Solid	Solid	Solid	Solid	Solid	Solid
Analyte/Methods (Units)						
Dioxins/Furans (Picogram/gram)						
1,2,3,4,6,7,8-Heptachlorodibenzo-p-dioxin	140 UB	240 UB	950 B	350 B	850	740
1,2,3,4,6,7,8-Heptachlorodibenzofuran	170 UB	260 UB	1100 B	390 B	1000	660
1,2,3,4,7,8,9-Heptachlorodibenzofuran	15 UB	13 TUB	42 B	15 B	38	38
1,2,3,4,7,8-Hexachlorodibenzo-p-dioxin	1.7 TJ	3.2 TJ	16 TB	7.5 TB	11 T	16
1,2,3,4,7,8-Hexachlorodibenzofuran	57 UB	65 UB	280 B	130 B	260	220
1,2,3,6,7,8-Hexachlorodibenzo-p-dioxin	11	16 T	58 B	25 B	50	67
1,2,3,6,7,8-Hexachlorodibenzofuran	11 UB	14 TUB	57 B	30 B	64	40
1,2,3,7,8,9-Hexachlorodibenzo-p-dioxin	6.3 TUB	11 TUB	36 TJ	14	36	28 J
1,2,3,7,8,9-Hexachlorodibenzofuran	16 UB	<19	4.9 TB	3.9 TB	6.4 TJ	3.6 TJ
1,2,3,7,8-Pentachlorodibenzo-p-dioxin	2.3 T	2.8 T	8.7 TJ	5.6 T	9.6 TJ	14
1,2,3,7,8-Pentachlorodibenzofuran	4.6 T	4.8 TJ	17 T	6.0 T	22	27
2,3,4,6,7,8-Hexachlorodibenzofuran	6.7 T	7.4 T	37 TB	14 B	32	26
2,3,4,7,8-Pentachlorodibenzofuran	14	16 T	56 B	26 B	49	52
2,3,7,8-Tetrachlorodibenzo-p-dioxin	94	82	420	370	1100	490
2,3,7,8-Tetrachlorodibenzofuran	7.0	28	110	18	34	37
Octachlorodibenzo-p-dioxin	1400 UB	4800 B	10000 B	3200 B	9300 B	6200 B
Octachlorodibenzofuran	240 UB	380 UB	1500 B	590 B	1000	760

Bold Bolded result indicates positively identified compound.
B Analyte detected in an associated blank.
J Data are estimated due to associated quality control data.
T Analyte was positively identified but the reported concentration is estimated; reported concentration is less than the reporting limit, but greater than the method detection limit.
UB Analyte considered not detected based on associated blank data.

TABLE 8

DIOXINS/FURANS SOLID SAMPLE DATA SUMMARY
DEMONSTRATION TESTING AND FULL-SCALE OPERATION OF THE BIOGENESIS SEDIMENT DECONTAMINATION PROCESS
KEASBEY, NEW JERSEY
 (Page 7 of 25)

Field Sample Identification	WS-270106-1402	TS-270106-1530	WS-270106-1531	RS-300106-1700	WS2-300106-1702	RS-310106-1700
Sediment Source	Lower Passaic River	Lower Passaic River	Lower Passaic River	Raritan River	Raritan River	Raritan River
Location Identification	WS	TS	WS	RS	WS2	RS
Date Collected	1/27/06	1/27/06	1/27/06	1/30/06	1/30/06	1/31/06
Matrix	Solid	Solid	Solid	Solid	Solid	Solid
Analyte/Methods (Units)						
Dioxins/Furans (Picogram/gram)						
1,2,3,4,6,7,8-Heptachlorodibenzo-p-dioxin	410	140	400	340 B	500 JB	160
1,2,3,4,6,7,8-Heptachlorodibenzofuran	520	320	530	260 B	570 JB	23 T
1,2,3,4,7,8,9-Heptachlorodibenzofuran	17 T	10	23	12 T	20	2.2 T
1,2,3,4,7,8-Hexachlorodibenzo-p-dioxin	4.8 TJ	1.9 T	4.3 T	4.0 TJ	6.8 T	2.2 T
1,2,3,4,7,8-Hexachlorodibenzofuran	130	70	130	75	150 J	5.8 TJ
1,2,3,6,7,8-Hexachlorodibenzo-p-dioxin	19 J	9.6	22	18 T	29	6.3 T
1,2,3,6,7,8-Hexachlorodibenzofuran	30	21	31	19 T	41	2.0 TJ
1,2,3,7,8,9-Hexachlorodibenzo-p-dioxin	16 TJ	6.7 T	16 T	17 T	21	7.4 T
1,2,3,7,8,9-Hexachlorodibenzofuran	2.9 TJ	1.4 TJ	<19	1.2 TJ	1.5 TJ	<60
1,2,3,7,8-Pentachlorodibenzo-p-dioxin	3.5 TJ	2.1 T	3.8 TJ	4.5 T	7.0 T	<60
1,2,3,7,8-Pentachlorodibenzofuran	8.2 T	5.0 T	6.6 T	7.0 T	14	1.6 TJ
2,3,4,6,7,8-Hexachlorodibenzofuran	18	7.9 T	18 T	11 T	15 J	1.9 T
2,3,4,7,8-Pentachlorodibenzofuran	23	12	22	18 T	33	4.0 T
2,3,7,8-Tetrachlorodibenzo-p-dioxin	150	93	160	750	220 J	2.3 T
2,3,7,8-Tetrachlorodibenzofuran	13 J	8.9	14	7.7 J	16	9.2 T
Octachlorodibenzo-p-dioxin	5500 B	1200 B	5300 B	9800 B	5800 JB	9800 B
Octachlorodibenzofuran	580	300	570	390 B	610 JB	32 TB

Bold Bolded result indicates positively identified compound.

B Analyte detected in an associated blank.

J Data are estimated due to associated quality control data.

T Analyte was positively identified but the reported concentration is estimated; reported concentration is less than the reporting limit, but greater than the method detection limit.

UB Analyte considered not detected based on associated blank data.

TABLE 8

DIOXINS/FURANS SOLID SAMPLE DATA SUMMARY
DEMONSTRATION TESTING AND FULL-SCALE OPERATION OF THE BIOGENESIS SEDIMENT DECONTAMINATION PROCESS
KEASBEY, NEW JERSEY
 (Page 8 of 25)

Field Sample Identification	TS-310106-1701	WS-310106-1702	RS-010206-1600	TS-010206-1601	WS-010206-1602	RS-020206-1800
Sediment Source	Raritan River	Raritan River	Raritan River	Raritan River	Raritan River	Raritan River
Location Identification	TS	WS	RS	TS	WS	RS
Date Collected	1/31/06	1/31/06	2/1/06	2/1/06	2/1/06	2/2/06
Matrix	Solid	Solid	Solid	Solid	Solid	Solid
Analyte/Methods (Units)						
Dioxins/Furans (Picogram/gram)						
1,2,3,4,6,7,8-Heptachlorodibenzo-p-dioxin	15	73	350	65	160	160
1,2,3,4,6,7,8-Heptachlorodibenzofuran	9.4	26	45	24	120	38
1,2,3,4,7,8,9-Heptachlorodibenzofuran	1.1 T	1.3 T	3.7 T	2.5 T	5.6 T	3.0 T
1,2,3,4,7,8-Hexachlorodibenzo-p-dioxin	<8.1	0.86 T	2.0 TJ	0.97 TJ	2.0 TJ	1.4 TJ
1,2,3,4,7,8-Hexachlorodibenzofuran	4.3 T	6.0 T	14 T	6.5 T	31	11 T
1,2,3,6,7,8-Hexachlorodibenzo-p-dioxin	1.1 TJ	2.8 T	6.6 T	4.0 T	7.9 T	6.1 T
1,2,3,6,7,8-Hexachlorodibenzofuran	1.4 T	1.7 T	4.0 TJ	2.3 T	8.0 T	3.2 TJ
1,2,3,7,8,9-Hexachlorodibenzo-p-dioxin	1.1 T	3.1 T	7.1 T	3.3 TJ	7.0 T	6.9 T
1,2,3,7,8,9-Hexachlorodibenzofuran	<8.1	<17	<23	<7.7	<15	<34
1,2,3,7,8-Pentachlorodibenzo-p-dioxin	<8.1	<17	1.4 TJ	1.2 TJ	1.5 TJ	2.1 T
1,2,3,7,8-Pentachlorodibenzofuran	0.89 TJ	1.1 T	2.3 TJ	2.1 T	3.5 T	2.6 T
2,3,4,6,7,8-Hexachlorodibenzofuran	1.4 T	1.1 T	3.3 T	2.0 T	4.4 T	3.3 TJ
2,3,4,7,8-Pentachlorodibenzofuran	1.8 T	1.3 TJ	4.7 T	3.8 T	7.4 T	3.4 TJ
2,3,7,8-Tetrachlorodibenzo-p-dioxin	4.9	4.5	4.8 J	7.2	34	5.8 T
2,3,7,8-Tetrachlorodibenzofuran	3.5	4.4	3.6 TJ	3.9	5.4	5.5 T
Octachlorodibenzo-p-dioxin	420 B	4100 B	10000 B	1800 B	4900 B	8300 B
Octachlorodibenzofuran	9.4 TB	27 TB	87	31	110	36 T

Bold Bolded result indicates positively identified compound.

B Analyte detected in an associated blank.

J Data are estimated due to associated quality control data.

T Analyte was positively identified but the reported concentration is estimated; reported concentration is less than the reporting limit, but greater than the method detection limit.

UB Analyte considered not detected based on associated blank data.

TABLE 8

DIOXINS/FURANS SOLID SAMPLE DATA SUMMARY
DEMONSTRATION TESTING AND FULL-SCALE OPERATION OF THE BIOGENESIS SEDIMENT DECONTAMINATION PROCESS
KEASBEY, NEW JERSEY
 (Page 9 of 25)

Field Sample Identification	TS-020206-1801	WS-020206-1802	RS-030206-1200	TS-030206-1201	WS-030206-1202	RS-060206-1930
Sediment Source	Raritan River	Raritan River	Raritan River	Raritan River	Raritan River	Raritan River
Location Identification	TS	WS	RS	TS	WS	RS
Date Collected	2/2/06	2/2/06	2/3/06	2/3/06	2/3/06	2/6/06
Matrix	Solid	Solid	Solid	Solid	Solid	Solid
Analyte/Methods (Units)						
Dioxins/Furans (Picogram/gram)						
1,2,3,4,6,7,8-Heptachlorodibenzo-p-dioxin	39	100	150	14	11 T	140
1,2,3,4,6,7,8-Heptachlorodibenzofuran	14	37	33 B	4.6 TB	2.2 TJB	29 B
1,2,3,4,7,8,9-Heptachlorodibenzofuran	1.1 TJ	2.3 T	2.7 T	<7.9	<17	2.8 T
1,2,3,4,7,8-Hexachlorodibenzo-p-dioxin	0.52 T	1.1 T	2.1 TJ	<7.9	<17	2.0 TJ
1,2,3,4,7,8-Hexachlorodibenzofuran	3.4 T	11 T	10 T	2.0 T	0.4 TJ	9.2 T
1,2,3,6,7,8-Hexachlorodibenzo-p-dioxin	2.2 TJ	4.5 T	6.0 T	1.0 TJ	<17	5.6 T
1,2,3,6,7,8-Hexachlorodibenzofuran	1.1 TJ	2.7 T	2.8 T	0.55 TJ	<17	2.8 T
1,2,3,7,8,9-Hexachlorodibenzo-p-dioxin	1.8 T	4.7 T	6.8 T	0.77 T	<17	6.3 T
1,2,3,7,8,9-Hexachlorodibenzofuran	<8.0	<17	<24	<7.9	<17	<25
1,2,3,7,8-Pentachlorodibenzo-p-dioxin	0.48 TJ	1.2 T	1.7 T	<7.9	<17	0.94 T
1,2,3,7,8-Pentachlorodibenzofuran	1.2 T	1.6 TJ	2.1 TJ	<7.9	<17	2.4 T
2,3,4,6,7,8-Hexachlorodibenzofuran	1.2 TJ	2.2 T	2.0 TJ	0.57 TJ	<17	2.4 TJB
2,3,4,7,8-Pentachlorodibenzofuran	2.6 T	3.5 T	3.9 T	1.1 T	<17	4.8 T
2,3,7,8-Tetrachlorodibenzo-p-dioxin	2.8	8.6	3.8 T	0.79 TJ	<3.5	3.8 T
2,3,7,8-Tetrachlorodibenzofuran	2.5	2.2 TJ	4.6 T	1.1 TJ	<3.5	8.5
Octachlorodibenzo-p-dioxin	1200 B	5100 B	8400 B	460 B	590 B	7800 B
Octachlorodibenzofuran	13 T	30 T	34 TJ	7.2 T	4.8 T	36 T

Bold Bolded result indicates positively identified compound.

B Analyte detected in an associated blank.

J Data are estimated due to associated quality control data.

T Analyte was positively identified but the reported concentration is estimated; reported concentration is less than the reporting limit, but greater than the method detection limit.

UB Analyte considered not detected based on associated blank data.

TABLE 8

DIOXINS/FURANS SOLID SAMPLE DATA SUMMARY
DEMONSTRATION TESTING AND FULL-SCALE OPERATION OF THE BIOGENESIS SEDIMENT DECONTAMINATION PROCESS
KEASBEY, NEW JERSEY
 (Page 10 of 25)

Field Sample Identification	TS-060206-1931	WS-060206-1932	SP-070206-1445	RS-070206-1630	TS-070206-1631	TS-070206-1631 DRIED
Sediment Source	Raritan River	Raritan River	Raritan River	Raritan River	Raritan River	Raritan River
Location Identification	TS	WS	PPS	RS	TS	TS
Date Collected	2/6/06	2/6/06	2/7/06	2/7/06	2/7/06	2/7/06
Matrix	Solid	Solid	Solid	Solid	Solid	Solid
Analyte/Methods (Units)						
Dioxins/Furans (Picogram/gram)						
1,2,3,4,6,7,8-Heptachlorodibenzo-p-dioxin	11	23	580	160	13	1400
1,2,3,4,6,7,8-Heptachlorodibenzofuran	4.7 TJB	5.9 TJB	360	31 T	3.8 TJ	31 B
1,2,3,4,7,8,9-Heptachlorodibenzofuran	0.42 TJ	<17	31	3.0 T	<7.8	1.5 TUB
1,2,3,4,7,8-Hexachlorodibenzo-p-dioxin	<7.9	<17	5.2 TJ	<39	<7.8	1.6 T
1,2,3,4,7,8-Hexachlorodibenzofuran	1.3 TJ	1.5 T	92	5.1 TJ	0.9 TJ	4.7 TB
1,2,3,6,7,8-Hexachlorodibenzo-p-dioxin	0.59 T	1.1 T	31	6.3 T	1.0 T	16
1,2,3,6,7,8-Hexachlorodibenzofuran	0.28 TJ	0.35 TJ	27	1.9 TJ	0.29 TJ	1.3 TJUB
1,2,3,7,8,9-Hexachlorodibenzo-p-dioxin	0.64 TJ	0.98 TJ	19	6.5 T	0.75 TJ	6.3 TJB
1,2,3,7,8,9-Hexachlorodibenzofuran	<7.9	<17	3.4 T	<39	<7.8	<6.5
1,2,3,7,8-Pentachlorodibenzo-p-dioxin	<7.9	<17	5.4 T	<39	<7.8	0.73 TJ
1,2,3,7,8-Pentachlorodibenzofuran	0.3 T	<17	15 J	2.3 TJ	0.29 TJ	1.3 TUB
2,3,4,6,7,8-Hexachlorodibenzofuran	0.23 TUB	<17	20	2.0 T	<7.8	1.1 TUB
2,3,4,7,8-Pentachlorodibenzofuran	0.43 TJ	<17	24	4.1 TJ	0.57 T	2.2 TB
2,3,7,8-Tetrachlorodibenzo-p-dioxin	0.52 TJ	0.99 TJ	70	4.8 T	<1.6	2.6
2,3,7,8-Tetrachlorodibenzofuran	1.4 T	1.8 T	21 J	9.0 J	0.87 TJ	2.5 J
Octachlorodibenzo-p-dioxin	390 B	1300 B	7200 B	9000 B	520 JB	7500 JB
Octachlorodibenzofuran	5.1 T	6.5 T	650 B	32 TJB	6.4 TB	86 B

- Bold** Bolded result indicates positively identified compound.
B Analyte detected in an associated blank.
J Data are estimated due to associated quality control data.
T Analyte was positively identified but the reported concentration is estimated; reported concentration is less than the reporting limit, but greater than the method detection limit.
UB Analyte considered not detected based on associated blank data.

TABLE 8

DIOXINS/FURANS SOLID SAMPLE DATA SUMMARY
DEMONSTRATION TESTING AND FULL-SCALE OPERATION OF THE BIOGENESIS SEDIMENT DECONTAMINATION PROCESS
KEASBEY, NEW JERSEY
 (Page 11 of 25)

Field Sample Identification	WS-070206-1632	RS-080206-1700	TS-080206-1701	WS-080206-1702	RS-090206-2300	TS-090206-2301
Sediment Source	Raritan River	Raritan River	Raritan River	Raritan River	Arthur Kill	Arthur Kill
Location Identification	WS	RS	TS	WS	RS	TS
Date Collected	2/7/06	2/8/06	2/8/06	2/8/06	2/9/06	2/9/06
Matrix	Solid	Solid	Solid	Solid	Solid	Solid
Analyte/Methods (Units)						
Dioxins/Furans (Picogram/gram)						
1,2,3,4,6,7,8-Heptachlorodibenzo-p-dioxin	44	150	11	20	380	88
1,2,3,4,6,7,8-Heptachlorodibenzofuran	7.7 T	30 B	2.7 TJB	3.6 TJB	240	51
1,2,3,4,7,8,9-Heptachlorodibenzofuran	<16	2.0 TJ	0.43 T	<17	19 T	4.0 TJ
1,2,3,4,7,8-Hexachlorodibenzo-p-dioxin	<16	1.8 TJ	<7.8	<17	3.9 T	1.1 TJ
1,2,3,4,7,8-Hexachlorodibenzofuran	2.2 T	8.7 T	1.1 T	0.96 T	66	15
1,2,3,6,7,8-Hexachlorodibenzo-p-dioxin	<16	6.1 T	0.56 TJ	<17	20 T	5.5 T
1,2,3,6,7,8-Hexachlorodibenzofuran	<16	2.8 T	0.34 TJ	<17	18 T	4.3 TJ
1,2,3,7,8,9-Hexachlorodibenzo-p-dioxin	<16	5.9 TJ	0.43 TJ	<17	15 T	4.4 T
1,2,3,7,8,9-Hexachlorodibenzofuran	<16	<15	<7.8	<17	2.1 TJ	<7.7
1,2,3,7,8-Pentachlorodibenzo-p-dioxin	<16	1.6 T	<7.8	<17	3.1 TJ	1.3 T
1,2,3,7,8-Pentachlorodibenzofuran	<16	2.5 T	0.24 TJ	<17	11 TJ	3.5 T
2,3,4,6,7,8-Hexachlorodibenzofuran	<16	2.8 T	0.28 T	<17	13 TJ	3.2 T
2,3,4,7,8-Pentachlorodibenzofuran	<16	4.1 TJ	0.85 TJ	0.42 TJ	18 T	4.6 T
2,3,7,8-Tetrachlorodibenzo-p-dioxin	<3.2	14	0.72 T	<3.4	38	14
2,3,7,8-Tetrachlorodibenzofuran	0.58 TJ	9.7	1.5 TJ	1.3 TJ	49 J	12 J
Octachlorodibenzo-p-dioxin	1800 B	8500 B	420 B	1100 B	5800 B	1700 B
Octachlorodibenzofuran	15 TB	47	3.9 T	6.3 T	240	82

- Bold** Bolded result indicates positively identified compound.
B Analyte detected in an associated blank.
J Data are estimated due to associated quality control data.
T Analyte was positively identified but the reported concentration is estimated; reported concentration is less than the reporting limit, but greater than the method detection limit.
UB Analyte considered not detected based on associated blank data.

TABLE 8

DIOXINS/FURANS SOLID SAMPLE DATA SUMMARY
DEMONSTRATION TESTING AND FULL-SCALE OPERATION OF THE BIOGENESIS SEDIMENT DECONTAMINATION PROCESS
KEASBEY, NEW JERSEY
 (Page 12 of 25)

Field Sample Identification	WS-090206-2302	RS-130206-1700	TS-130206-1701	WS-130206-1702	RS-140206-1330	TS-140206-1331
Sediment Source	Arthur Kill	Lower Passaic River	Lower Passaic River	Lower Passaic River	Arthur Kill	Arthur Kill
Location Identification	WS	RS	TS	WS	RS	TS
Date Collected	2/9/06	2/13/06	2/13/06	2/13/06	2/14/06	2/14/06
Matrix	Solid	Solid	Solid	Solid	Solid	Solid
Analyte/Methods (Units)						
Dioxins/Furans (Picogram/gram)						
1,2,3,4,6,7,8-Heptachlorodibenzo-p-dioxin	270	1100	110	280	2500 B	110 B
1,2,3,4,6,7,8-Heptachlorodibenzofuran	130	1200	84	180	610	51
1,2,3,4,7,8,9-Heptachlorodibenzofuran	12 T	53	5.1 T	16 T	49 B	3.4 TB
1,2,3,4,7,8-Hexachlorodibenzo-p-dioxin	2.3 TJ	14 TJ	1.0 TJ	2.5 TJ	8.8 TJ	0.48 TJ
1,2,3,4,7,8-Hexachlorodibenzofuran	32	320 J	25 J	44	110	16 J
1,2,3,6,7,8-Hexachlorodibenzo-p-dioxin	13 T	78	6.8 T	15 T	67	4.9 T
1,2,3,6,7,8-Hexachlorodibenzofuran	9.9 T	74	6.9 T	12 TJ	33	4.1 T
1,2,3,7,8,9-Hexachlorodibenzo-p-dioxin	9.7 T	44 T	3.7 TJ	12 T	36	3.2 TJ
1,2,3,7,8,9-Hexachlorodibenzofuran	1.5 TJ	<53	1.2 TJ	<21	5.3 TB	<7.2
1,2,3,7,8-Pentachlorodibenzo-p-dioxin	2.8 T	10 TJ	1.7 T	2.3 TJ	8.2 TJ	1.0 TJ
1,2,3,7,8-Pentachlorodibenzofuran	5.7 T	25 T	3.8 T	8.4 T	23 T	2.5 T
2,3,4,6,7,8-Hexachlorodibenzofuran	7.3 T	39 TJ	4.3 T	8.1 TJ	24	2.4 T
2,3,4,7,8-Pentachlorodibenzofuran	8.1 TJ	80	7.9 TJ	13 T	28	4.6 T
2,3,7,8-Tetrachlorodibenzo-p-dioxin	38	970	51	27	66	21
2,3,7,8-Tetrachlorodibenzofuran	5.8	95 J	7.6	10 J	34 J	2.8 J
Octachlorodibenzo-p-dioxin	6100 B	12000	1000	3700	16000 B	1300 B
Octachlorodibenzofuran	120	1800 J	140	300	1300 B	78 B

Bold Bolded result indicates positively identified compound.

B Analyte detected in an associated blank.

J Data are estimated due to associated quality control data.

T Analyte was positively identified but the reported concentration is estimated; reported concentration is less than the reporting limit, but greater than the method detection limit.

UB Analyte considered not detected based on associated blank data.

TABLE 8

DIOXINS/FURANS SOLID SAMPLE DATA SUMMARY
DEMONSTRATION TESTING AND FULL-SCALE OPERATION OF THE BIOGENESIS SEDIMENT DECONTAMINATION PROCESS
KEASBEY, NEW JERSEY
 (Page 13 of 25)

Field Sample Identification	WS-140206-1332	RS-160206-1500	TS-160206-1501	WS-160206-1502	RS-170206-1100	TS-170206-1101
Sediment Source	Arthur Kill	Arthur Kill	Arthur Kill	Arthur Kill	Arthur Kill	Arthur Kill
Location Identification	WS	RS	TS	WS	RS	TS
Date Collected	2/14/06	2/16/06	2/16/06	2/16/06	2/17/06	2/17/06
Matrix	Solid	Solid	Solid	Solid	Solid	Solid
Analyte/Methods (Units)						
Dioxins/Furans (Picogram/gram)						
1,2,3,4,6,7,8-Heptachlorodibenzo-p-dioxin	510 B	510	90	65	540	54
1,2,3,4,6,7,8-Heptachlorodibenzofuran	360	320	41	45	1400	30
1,2,3,4,7,8,9-Heptachlorodibenzofuran	24 B	23	3.7 TJ	4.0 TJ	53 J	3.5 TJ
1,2,3,4,7,8-Hexachlorodibenzo-p-dioxin	4.5 TJ	7.1 TJ	0.84 TJ	<19	4.7 TJ	0.97 T
1,2,3,4,7,8-Hexachlorodibenzofuran	87 J	78	13	11 T	320	11
1,2,3,6,7,8-Hexachlorodibenzo-p-dioxin	29	32	3.7 TJ	4.0 TJ	31	3.5 TJ
1,2,3,6,7,8-Hexachlorodibenzofuran	24	25	4.1 T	2.9 T	62 J	3.4 T
1,2,3,7,8,9-Hexachlorodibenzo-p-dioxin	21	20	3.9 T	<19	23	2.8 T
1,2,3,7,8,9-Hexachlorodibenzofuran	4.3 TB	<17	<7.4	<19	<16	<6.9
1,2,3,7,8-Pentachlorodibenzo-p-dioxin	5.2 T	5.3 TJ	<7.4	<19	7.4 TJ	1.0 T
1,2,3,7,8-Pentachlorodibenzofuran	13 TJ	14 T	3.4 T	2.5 T	16 J	1.9 TJ
2,3,4,6,7,8-Hexachlorodibenzofuran	15 T	16 T	2.7 T	2.6 TJ	23	2.8 TJ
2,3,4,7,8-Pentachlorodibenzofuran	23	24	5.4 T	2.9 T	22	3.6 T
2,3,7,8-Tetrachlorodibenzo-p-dioxin	71	87	22	6.0 J	49	6.5
2,3,7,8-Tetrachlorodibenzofuran	16 J	24 J	3.7 J	1.7 TJ	24	2.5 J
Octachlorodibenzo-p-dioxin	6800 B	6400	1000	870	6700 B	480 B
Octachlorodibenzofuran	500 B	540	75	69	1700	36

- Bold** Bolded result indicates positively identified compound.
B Analyte detected in an associated blank.
J Data are estimated due to associated quality control data.
T Analyte was positively identified but the reported concentration is estimated; reported concentration is less than the reporting limit, but greater than the method detection limit.
UB Analyte considered not detected based on associated blank data.

TABLE 8

DIOXINS/FURANS SOLID SAMPLE DATA SUMMARY
DEMONSTRATION TESTING AND FULL-SCALE OPERATION OF THE BIOGENESIS SEDIMENT DECONTAMINATION PROCESS
KEASBEY, NEW JERSEY
 (Page 14 of 25)

Field Sample Identification	WS-170206-1102	TS-230206-0930	TS-230206-0930 DRIED	RS-270206-1400	TS-270206-1350	TS-270206-1350 DRIED
Sediment Source	Arthur Kill	Arthur Kill	Arthur Kill	Lower Passaic River	Lower Passaic River	Lower Passaic River
Location Identification	WS	TS	TS	RS	TS	TS
Date Collected	2/17/06	2/23/06	2/23/06	2/27/06	2/27/06	2/27/06
Matrix	Solid	Solid	Solid	Solid	Solid	Solid
Analyte/Methods (Units)						
Dioxins/Furans (Picogram/gram)						
1,2,3,4,6,7,8-Heptachlorodibenzo-p-dioxin	110	61 J	43 J	710	120	110
1,2,3,4,6,7,8-Heptachlorodibenzofuran	74	36 JB	23 JB	620	100	81
1,2,3,4,7,8,9-Heptachlorodibenzofuran	5.5 TJ	3.3 TB	2.5 TB	27 J	5.1 TJ	4.2 T
1,2,3,4,7,8-Hexachlorodibenzo-p-dioxin	1.9 TJ	0.89 TJ	0.71 TJ	11 T	1.3 T	1.5 T
1,2,3,4,7,8-Hexachlorodibenzofuran	19	11 JB	7.6 JB	160	30 J	20 J
1,2,3,6,7,8-Hexachlorodibenzo-p-dioxin	6.2 T	3.1 TJ	2.9 T	49	7.1 T	6.6 T
1,2,3,6,7,8-Hexachlorodibenzofuran	6.0 T	3.2 TB	2.6 TB	47 J	6.4 T	5.4 T
1,2,3,7,8,9-Hexachlorodibenzo-p-dioxin	4.4 TJ	2.0 TJUB	1.8 TJUB	30	4.6 T	4.0 T
1,2,3,7,8,9-Hexachlorodibenzofuran	<17	<7.0	<7.0	3.1 TJ	0.56 T	<7.3
1,2,3,7,8-Pentachlorodibenzo-p-dioxin	2.2 T	0.82 TJ	0.51 TJ	7.6 TJ	1.4 TJ	1.5 T
1,2,3,7,8-Pentachlorodibenzofuran	4.1 T	2.5 TB	1.8 TJUB	16	3.1 T	2.5 TJ
2,3,4,6,7,8-Hexachlorodibenzofuran	4.2 TJ	2.0 TJB	2.0 TB	21 J	3.2 T	3.3 T
2,3,4,7,8-Pentachlorodibenzofuran	5.3 TJ	3.9 TB	3.0 TB	50	6.4 T	6.5 T
2,3,7,8-Tetrachlorodibenzo-p-dioxin	12	7.6 J	5.8 J	290	28	31
2,3,7,8-Tetrachlorodibenzofuran	4.5 J	4.0	3.0	35	6.8	6.9
Octachlorodibenzo-p-dioxin	1300 B	690 JB	550 JB	7900 B	1200 B	1100 B
Octachlorodibenzofuran	89	41 JB	28 JB	960	63	41 J

- Bold** Bolded result indicates positively identified compound.
B Analyte detected in an associated blank.
J Data are estimated due to associated quality control data.
T Analyte was positively identified but the reported concentration is estimated; reported concentration is less than the reporting limit, but greater than the method detection limit.
UB Analyte considered not detected based on associated blank data.

TABLE 8

DIOXINS/FURANS SOLID SAMPLE DATA SUMMARY
DEMONSTRATION TESTING AND FULL-SCALE OPERATION OF THE BIOGENESIS SEDIMENT DECONTAMINATION PROCESS
KEASBEY, NEW JERSEY
 (Page 15 of 25)

Field Sample Identification	TS-270206-1630	TS-270206-1630 DRIED	RS-280206-1700	TS-280206-1705	WS-280206-1710	RS-010306-1700
Sediment Source	Lower Passaic River	Lower Passaic River	Arthur Kill	Arthur Kill	Arthur Kill	Arthur Kill
Location Identification	TS	TS	RS	TS	WS	RS
Date Collected	2/27/06	2/27/06	2/28/06	2/28/06	2/28/06	3/1/06
Matrix	Solid	Solid	Solid	Solid	Solid	Solid
Analyte/Methods (Units)						
Dioxins/Furans (Picogram/gram)						
1,2,3,4,6,7,8-Heptachlorodibenzo-p-dioxin	130	65	640	140	130	300
1,2,3,4,6,7,8-Heptachlorodibenzofuran	110	62	380	76	82	170
1,2,3,4,7,8,9-Heptachlorodibenzofuran	4.5 T	2.9 T	33	6.3 TJ	4.9 TJ	16 TJB
1,2,3,4,7,8-Hexachlorodibenzo-p-dioxin	1.8 TJ	1.2 T	8.8 T	1.1 TJ	<20	4.5 T
1,2,3,4,7,8-Hexachlorodibenzofuran	30 J	16 J	95	23 J	21	48 J
1,2,3,6,7,8-Hexachlorodibenzo-p-dioxin	9.0	5.1 T	43	7.9	6.0 TJ	20
1,2,3,6,7,8-Hexachlorodibenzofuran	7.3	3.4 T	31	6.2 T	6.1 T	17 T
1,2,3,7,8,9-Hexachlorodibenzo-p-dioxin	5.5 T	2.8 T	27	5.7 T	3.8 T	12 T
1,2,3,7,8,9-Hexachlorodibenzofuran	<7.0	<6.7	3.2 T	<7.5	<20	1.6 TJ
1,2,3,7,8-Pentachlorodibenzo-p-dioxin	1.5 T	1.3 T	7.4 TJ	1.7 TJ	<20	3.3 TJ
1,2,3,7,8-Pentachlorodibenzofuran	3.1 TJ	1.8 T	19	5.3 T	3.8 T	11 T
2,3,4,6,7,8-Hexachlorodibenzofuran	4.4 TJ	2.1 T	18	5.1 T	4.5 TJ	11 T
2,3,4,7,8-Pentachlorodibenzofuran	9.3	5.3 T	32	8.6	5.2 T	17 T
2,3,7,8-Tetrachlorodibenzo-p-dioxin	59	41	62	20 J	13	32
2,3,7,8-Tetrachlorodibenzofuran	9.0	5.2	28 J	9.3	6.0 J	19
Octachlorodibenzo-p-dioxin	1200 B	650 B	7900 B	1400 B	1400 B	3200 B
Octachlorodibenzofuran	53	54	560	130	130	300 JB

- Bold** Bolded result indicates positively identified compound.
B Analyte detected in an associated blank.
J Data are estimated due to associated quality control data.
T Analyte was positively identified but the reported concentration is estimated; reported concentration is less than the reporting limit, but greater than the method detection limit.
UB Analyte considered not detected based on associated blank data.

TABLE 8

DIOXINS/FURANS SOLID SAMPLE DATA SUMMARY
DEMONSTRATION TESTING AND FULL-SCALE OPERATION OF THE BIOGENESIS SEDIMENT DECONTAMINATION PROCESS
KEASBEY, NEW JERSEY
 (Page 16 of 25)

Field Sample Identification	TS-010306-1705	WS-010306-1710	RS-020306-1700	SS-020306-1400	TS-020306-1705	WS-020306-1710
Sediment Source	Arthur Kill	Arthur Kill	Arthur Kill	Arthur Kill	Arthur Kill	Arthur Kill
Location Identification	TS	WS	RS	SS1	TS	WS
Date Collected	3/1/06	3/1/06	3/2/06	3/2/06	3/2/06	3/2/06
Matrix	Solid	Solid	Solid	Solid	Solid	Solid
Analyte/Methods (Units)						
Dioxins/Furans (Picogram/gram)						
1,2,3,4,6,7,8-Heptachlorodibenzo-p-dioxin	260	81	580	140	140	36
1,2,3,4,6,7,8-Heptachlorodibenzofuran	140	49	310	55	70	24
1,2,3,4,7,8,9-Heptachlorodibenzofuran	10 B	5.2 TB	26	4.7 T	5.6 T	1.9 T
1,2,3,4,7,8-Hexachlorodibenzo-p-dioxin	3.3 T	0.91 TJ	7.3 TJ	2.3 T	1.3 T	<18
1,2,3,4,7,8-Hexachlorodibenzofuran	34	14 TJ	74 J	27 J	19 J	5.3 T
1,2,3,6,7,8-Hexachlorodibenzo-p-dioxin	14	4.6 T	28	7.5 TJ	6.6 T	2.3 T
1,2,3,6,7,8-Hexachlorodibenzofuran	12	3.5 TJ	20 J	7.6 T	6.0 T	1.9 TJ
1,2,3,7,8,9-Hexachlorodibenzo-p-dioxin	8.6	2.7 TJ	19 T	4.6 TJ	4.9 T	1.6 TJ
1,2,3,7,8,9-Hexachlorodibenzofuran	<8.0	<18	1.6 T	<10	<8.2	<18
1,2,3,7,8-Pentachlorodibenzo-p-dioxin	3.0 T	0.73 TJ	4.7 TJ	1.7 TJ	1.5 T	<18
1,2,3,7,8-Pentachlorodibenzofuran	6.8 T	2.7 T	12 T	4.8 TJ	3.9 T	1.3 TJ
2,3,4,6,7,8-Hexachlorodibenzofuran	6.9 T	2.8 T	16 T	4.1 T	4.3 T	1.4 TJ
2,3,4,7,8-Pentachlorodibenzofuran	9.6	3.3 T	23 J	31	7.2 T	1.5 TJ
2,3,7,8-Tetrachlorodibenzo-p-dioxin	20	7.9	39	21	12	3.3 T
2,3,7,8-Tetrachlorodibenzofuran	11 J	4.0 J	26	11 J	7.9 J	3.4 TJ
Octachlorodibenzo-p-dioxin	2900 B	940 B	7600 B	1300 B	1600 B	430 B
Octachlorodibenzofuran	200 B	73 B	960	110	140	40

- Bold** Bolded result indicates positively identified compound.
B Analyte detected in an associated blank.
J Data are estimated due to associated quality control data.
T Analyte was positively identified but the reported concentration is estimated; reported concentration is less than the reporting limit, but greater than the method detection limit.
UB Analyte considered not detected based on associated blank data.

TABLE 8

DIOXINS/FURANS SOLID SAMPLE DATA SUMMARY
DEMONSTRATION TESTING AND FULL-SCALE OPERATION OF THE BIOGENESIS SEDIMENT DECONTAMINATION PROCESS
KEASBEY, NEW JERSEY
 (Page 17 of 25)

Field Sample Identification	RS-030306-1200	TS-030306-1205	WS-030306-1210	RS-060406-1215	TS-060406-1240	WS-060406-1300
Sediment Source	Arthur Kill	Arthur Kill	Arthur Kill	Arthur Kill	Arthur Kill	Arthur Kill
Location Identification	RS	TS	WS	RS	TS	WS
Date Collected	3/3/06	3/3/06	3/3/06	4/6/06	4/6/06	4/6/06
Matrix	Solid	Solid	Solid	Solid	Solid	Solid
Analyte/Methods (Units)						
Dioxins/Furans (Picogram/gram)						
1,2,3,4,6,7,8-Heptachlorodibenzo-p-dioxin	510	180	60	540 B	34 B	120 B
1,2,3,4,6,7,8-Heptachlorodibenzofuran	300	96	32	360 B	28 B	76 B
1,2,3,4,7,8,9-Heptachlorodibenzofuran	19	7.7 T	2.1 TJ	29 J	3.1 T	6.1 T
1,2,3,4,7,8-Hexachlorodibenzo-p-dioxin	5.9 T	2.0 TJ	<19	9.2 TJ	0.46 TJ	1.3 TJ
1,2,3,4,7,8-Hexachlorodibenzofuran	75 J	27 J	7.1 T	66	6.9 T	13 T
1,2,3,6,7,8-Hexachlorodibenzo-p-dioxin	28	9.6	2.5 TJ	34	2.7 T	7.7 T
1,2,3,6,7,8-Hexachlorodibenzofuran	24	8.1 T	3.4 TJ	31 JB	3.3 TB	5.7 TB
1,2,3,7,8,9-Hexachlorodibenzo-p-dioxin	19	6.7 T	<19	20 J	1.4 T	4.6 T
1,2,3,7,8,9-Hexachlorodibenzofuran	2.1 T	<8.8	<19	4.6 TJ	0.36 TJ	0.64 T
1,2,3,7,8-Pentachlorodibenzo-p-dioxin	6.0 T	<8.8	<19	6.7 TJ	0.52 TJ	1.5 TJ
1,2,3,7,8-Pentachlorodibenzofuran	14 T	3.9 TJ	<19	16 J	1.7 T	3.6 TJ
2,3,4,6,7,8-Hexachlorodibenzofuran	17 J	5.7 T	1.8 T	19	2.2 T	3.6 TJ
2,3,4,7,8-Pentachlorodibenzofuran	23	8.4 T	2.2 T	23 J	2.7 T	4.7 T
2,3,7,8-Tetrachlorodibenzo-p-dioxin	42	20	5.6	55	4.3 J	11
2,3,7,8-Tetrachlorodibenzofuran	23 J	9.6	2.3 TJ	29	3.8	9.2
Octachlorodibenzo-p-dioxin	6600 JB	2100 B	710 B	6500 B	350 JB	1400 B
Octachlorodibenzofuran	580	200	57	520 B	47 B	120 B

- Bold** Bolded result indicates positively identified compound.
B Analyte detected in an associated blank.
J Data are estimated due to associated quality control data.
T Analyte was positively identified but the reported concentration is estimated; reported concentration is less than the reporting limit, but greater than the method detection limit.
UB Analyte considered not detected based on associated blank data.

TABLE 8

DIOXINS/FURANS SOLID SAMPLE DATA SUMMARY
DEMONSTRATION TESTING AND FULL-SCALE OPERATION OF THE BIOGENESIS SEDIMENT DECONTAMINATION PROCESS
KEASBEY, NEW JERSEY
 (Page 18 of 25)

Field Sample Identification	RS-100406-1525	TS-100406-1615	WS-100406-1630	RS-120406-1815	TS-120406-1835	WS-120406-1840
Sediment Source	Arthur Kill	Arthur Kill	Arthur Kill	Arthur Kill	Arthur Kill	Arthur Kill
Location Identification	RS	TS	WS	RS	TS	WS
Date Collected	4/10/06	4/10/06	4/10/06	4/12/06	4/12/06	4/12/06
Matrix	Solid	Solid	Solid	Solid	Solid	Solid
Analyte/Methods (Units)						
Dioxins/Furans (Picogram/gram)						
1,2,3,4,6,7,8-Heptachlorodibenzo-p-dioxin	600 B	160 B	120 B	530 B	68 B	120 B
1,2,3,4,6,7,8-Heptachlorodibenzofuran	380 B	79 B	80 B	370 JB	35 B	77 B
1,2,3,4,7,8,9-Heptachlorodibenzofuran	27 J	7.9 J	7.7 T	39 J	3.6 TJ	6.9 TJ
1,2,3,4,7,8-Hexachlorodibenzo-p-dioxin	9.2 TJ	2.2 T	1.3 T	5.8 T	0.71 TJ	1.5 TJ
1,2,3,4,7,8-Hexachlorodibenzofuran	66	17	16 T	66 J	7.0 T	14 T
1,2,3,6,7,8-Hexachlorodibenzo-p-dioxin	37	12	9.3 T	39	4.8 T	6.4 TJ
1,2,3,6,7,8-Hexachlorodibenzofuran	27 JB	7.3 TB	6.2 TB	30 B	3.2 TB	6.0 TB
1,2,3,7,8,9-Hexachlorodibenzo-p-dioxin	20 J	5.2 T	4.5 TJ	17	1.8 T	3.8 T
1,2,3,7,8,9-Hexachlorodibenzofuran	5.6 TJ	0.47 TJ	<20	2.3 TJ	0.3 T	<18
1,2,3,7,8-Pentachlorodibenzo-p-dioxin	6.5 TJ	2.4 T	1.3 TJ	6.8 T	1.1 TJ	1.3 TJ
1,2,3,7,8-Pentachlorodibenzofuran	17	5.8 TJ	4.4 T	20 J	2.4 T	3.5 TJ
2,3,4,6,7,8-Hexachlorodibenzofuran	20	5.5 T	4.7 T	19	2.3 T	4.1 T
2,3,4,7,8-Pentachlorodibenzofuran	23 J	6.9 T	6.1 T	22	3.0 T	5.0 T
2,3,7,8-Tetrachlorodibenzo-p-dioxin	60	21	13	57	15	11
2,3,7,8-Tetrachlorodibenzofuran	29	11 J	9.3	31	4.6	3.4 TJ
Octachlorodibenzo-p-dioxin	7100 B	1600 B	1400 B	6500 B	790 B	1400 B
Octachlorodibenzofuran	570 B	130 B	130 B	580 B	56 B	120 B

Bold Bolded result indicates positively identified compound.

B Analyte detected in an associated blank.

J Data are estimated due to associated quality control data.

T Analyte was positively identified but the reported concentration is estimated; reported concentration is less than the reporting limit, but greater than the method detection limit.

UB Analyte considered not detected based on associated blank data.

TABLE 8

DIOXINS/FURANS SOLID SAMPLE DATA SUMMARY
DEMONSTRATION TESTING AND FULL-SCALE OPERATION OF THE BIOGENESIS SEDIMENT DECONTAMINATION PROCESS
KEASBEY, NEW JERSEY
 (Page 19 of 25)

Field Sample Identification	RS-170406-1725	TS-170406-1745	WS-170406-1745	PSS-200406-1600	RS-200406-1615	TS-200406-1635
Sediment Source	Arthur Kill	Arthur Kill	Arthur Kill	Arthur Kill	Arthur Kill	Arthur Kill
Location Identification	RS	TS	WS	PSS	RS	TS
Date Collected	4/17/06	4/17/06	4/17/06	4/20/06	4/20/06	4/20/06
Matrix	Solid	Solid	Solid	Solid	Solid	Solid
Analyte/Methods (Units)						
Dioxins/Furans (Picogram/gram)						
1,2,3,4,6,7,8-Heptachlorodibenzo-p-dioxin	560	61	230	860	430	25
1,2,3,4,6,7,8-Heptachlorodibenzofuran	510	31	160	380	290	14
1,2,3,4,7,8,9-Heptachlorodibenzofuran	28 J	2.9 TJ	13 T	32	23	1.3 TJ
1,2,3,4,7,8-Hexachlorodibenzo-p-dioxin	8.2 T	0.6 TJ	2.1 TJ	<7.6	5.8 T	0.29 TJ
1,2,3,4,7,8-Hexachlorodibenzofuran	75 J	10 J	36 J	76	72 J	4.5 TJ
1,2,3,6,7,8-Hexachlorodibenzo-p-dioxin	32	3.7 T	15 T	36	34	1.5 T
1,2,3,6,7,8-Hexachlorodibenzofuran	29 J	2.7 T	9.4 T	34	25 J	1.2 T
1,2,3,7,8,9-Hexachlorodibenzo-p-dioxin	20	2.2 T	8.8 T	24	17 T	1.0 T
1,2,3,7,8,9-Hexachlorodibenzofuran	3.6 TB	<7.0	<18	<2.1	3.1 TJB	<7.1
1,2,3,7,8-Pentachlorodibenzo-p-dioxin	1.4 TJ	0.79 T	2.5 T	<7.4	4.0 TJ	0.57 T
1,2,3,7,8-Pentachlorodibenzofuran	12 TJ	2.1 T	6.1 TJ	23	13 TJ	1.1 T
2,3,4,6,7,8-Hexachlorodibenzofuran	17	2.2 TJ	6.5 T	29 J	16 TJ	0.84 T
2,3,4,7,8-Pentachlorodibenzofuran	17	3.3 T	9.7 T	27	23	1.3 TJ
2,3,7,8-Tetrachlorodibenzo-p-dioxin	37 J	6.4	19	67	37	3.2
2,3,7,8-Tetrachlorodibenzofuran	27	3.9 J	11 J	34	25	2.7 J
Octachlorodibenzo-p-dioxin	6500 B	680 B	2800 B	9700	5500 B	280 JB
Octachlorodibenzofuran	910 B	53 B	250 B	660	440 B	21 B

- Bold** Bolded result indicates positively identified compound.
B Analyte detected in an associated blank.
J Data are estimated due to associated quality control data.
T Analyte was positively identified but the reported concentration is estimated; reported concentration is less than the reporting limit, but greater than the method detection limit.
UB Analyte considered not detected based on associated blank data.

TABLE 8

DIOXINS/FURANS SOLID SAMPLE DATA SUMMARY
DEMONSTRATION TESTING AND FULL-SCALE OPERATION OF THE BIOGENESIS SEDIMENT DECONTAMINATION PROCESS
KEASBEY, NEW JERSEY
 (Page 20 of 25)

Field Sample Identification	WS-200406-1640	RS-250406-1815	TS-250406-1835	WS-250406-1840	RS-270406-1715	TS-270406-1735
Sediment Source	Arthur Kill	Arthur Kill	Arthur Kill	Arthur Kill	Arthur Kill	Arthur Kill
Location Identification	WS	RS	TS	WS	RS	TS
Date Collected	4/20/06	4/25/06	4/25/06	4/25/06	4/27/06	4/27/06
Matrix	Solid	Solid	Solid	Solid	Solid	Solid
Analyte/Methods (Units)						
Dioxins/Furans (Picogram/gram)						
1,2,3,4,6,7,8-Heptachlorodibenzo-p-dioxin	120	490	54	140	550	85
1,2,3,4,6,7,8-Heptachlorodibenzofuran	73	470	31	98	380	36
1,2,3,4,7,8,9-Heptachlorodibenzofuran	7.2 T	64	2.4 T	8.8 T	32	3.0 T
1,2,3,4,7,8-Hexachlorodibenzo-p-dioxin	1.4 T	7.0 T	0.45 TJ	1.8 T	6.8 T	0.51 TJ
1,2,3,4,7,8-Hexachlorodibenzofuran	19 J	94 J	9.0 J	26 J	93 J	9.9 J
1,2,3,6,7,8-Hexachlorodibenzo-p-dioxin	8.4 T	33	3.1 TJ	9.7 T	33	3.9 T
1,2,3,6,7,8-Hexachlorodibenzofuran	5.7 T	35	2.7 T	7.1 T	29	2.8 TJ
1,2,3,7,8,9-Hexachlorodibenzo-p-dioxin	4.2 T	19	2.1 T	5.7 T	20 T	2.5 T
1,2,3,7,8,9-Hexachlorodibenzofuran	<18	2.1 TB	0.54 TUB	1.1 TJB	1.7 TJB	<7.4
1,2,3,7,8-Pentachlorodibenzo-p-dioxin	1.2 TJ	5.5 T	0.68 TJ	1.7 TJ	5.1 TJ	0.88 T
1,2,3,7,8-Pentachlorodibenzofuran	3.9 T	14 TJ	1.8 TJ	4.7 TJ	18 T	2.1 T
2,3,4,6,7,8-Hexachlorodibenzofuran	3.9 T	20 J	2.0 T	4.7 T	17 T	2.1 T
2,3,4,7,8-Pentachlorodibenzofuran	5.1 T	22	3.6 T	6.8 T	25	3.1 T
2,3,7,8-Tetrachlorodibenzo-p-dioxin	11	44	6.4	13	55	7.2
2,3,7,8-Tetrachlorodibenzofuran	5.5 J	28 J	3.9 J	7.6	29	4.3
Octachlorodibenzo-p-dioxin	1400 B	6200 B	600 B	1800 B	6700 B	1100 B
Octachlorodibenzofuran	110 B	920 B	48 B	130 B	520 B	64 B

Bold Bolded result indicates positively identified compound.

B Analyte detected in an associated blank.

J Data are estimated due to associated quality control data.

T Analyte was positively identified but the reported concentration is estimated; reported concentration is less than the reporting limit, but greater than the method detection limit.

UB Analyte considered not detected based on associated blank data.

TABLE 8

DIOXINS/FURANS SOLID SAMPLE DATA SUMMARY
DEMONSTRATION TESTING AND FULL-SCALE OPERATION OF THE BIOGENESIS SEDIMENT DECONTAMINATION PROCESS
KEASBEY, NEW JERSEY
 (Page 21 of 25)

Field Sample Identification	WS-270406-1740	PSS-010506-1600	RS-010506-1615	TS-010506-1635	WS-010506-1640	PSS-030506-1600
Sediment Source	Arthur Kill	Lower Passaic River	Lower Passaic River	Lower Passaic River	Lower Passaic River	Lower Passaic River
Location Identification	WS	PSS	RS	TS	WS	PSS
Date Collected	4/27/06	5/1/06	5/1/06	5/1/06	5/1/06	5/3/06
Matrix	Solid	Solid	Solid	Solid	Solid	Solid
Analyte/Methods (Units)						
Dioxins/Furans (Picogram/gram)						
1,2,3,4,6,7,8-Heptachlorodibenzo-p-dioxin	550	830	820	110	170	730
1,2,3,4,6,7,8-Heptachlorodibenzofuran	330	1100 J	1000	120	200	910
1,2,3,4,7,8,9-Heptachlorodibenzofuran	32	38 J	39 J	6.3 TJ	9.7 T	30 J
1,2,3,4,7,8-Hexachlorodibenzo-p-dioxin	4.7 T	16 T	18 T	1.6 TJ	1.7 T	13 TJ
1,2,3,4,7,8-Hexachlorodibenzofuran	83 J	260 J	180	30 J	34	190 J
1,2,3,6,7,8-Hexachlorodibenzo-p-dioxin	32	65	56	9.8	12 T	58
1,2,3,6,7,8-Hexachlorodibenzofuran	25	64	91 J	9.3 J	12 TJ	56
1,2,3,7,8,9-Hexachlorodibenzo-p-dioxin	17 T	27 T	45 J	3.9 T	6.5 T	23 J
1,2,3,7,8,9-Hexachlorodibenzofuran	<20	34 J	1.1 TJ	0.36 TJ	<19	2.7 TJ
1,2,3,7,8-Pentachlorodibenzo-p-dioxin	5.7 TJ	9.5 T	13 TJ	1.7 T	2.1 TJ	9.3 T
1,2,3,7,8-Pentachlorodibenzofuran	16 T	27 TJ	24 J	3.8 TJ	4.1 T	21 J
2,3,4,6,7,8-Hexachlorodibenzofuran	18 T	26 T	25	4.0 T	6.0 T	22
2,3,4,7,8-Pentachlorodibenzofuran	21	80	68 J	10	8.3 T	63
2,3,7,8-Tetrachlorodibenzo-p-dioxin	50	1000	470	69	50	330
2,3,7,8-Tetrachlorodibenzofuran	27	38 J	37	8.1	8.8	27
Octachlorodibenzo-p-dioxin	6600 B	9500 B	10000 B	1000 B	2300 B	8000 B
Octachlorodibenzofuran	500 B	1300 J	1300 J	170 J	270	1100

- Bold** Bolded result indicates positively identified compound.
 B Analyte detected in an associated blank.
 J Data are estimated due to associated quality control data.
 T Analyte was positively identified but the reported concentration is estimated; reported concentration is less than the reporting limit, but greater than the method detection limit.
 UB Analyte considered not detected based on associated blank data.

TABLE 8

DIOXINS/FURANS SOLID SAMPLE DATA SUMMARY
DEMONSTRATION TESTING AND FULL-SCALE OPERATION OF THE BIOGENESIS SEDIMENT DECONTAMINATION PROCESS
KEASBEY, NEW JERSEY
 (Page 22 of 25)

Field Sample Identification	RS-030506-1615	TS-030506-1635	STS-3-030506-1200	STS-4-030506-1400	WS-030506-1640	CARBON TANKS
Sediment Source	Lower Passaic River	Lower Passaic River	Lower Passaic River	Lower Passaic River	Lower Passaic River	None
Location Identification	RS	TS	TS	TS	WS	CAR
Date Collected	5/3/06	5/3/06	5/3/06	5/3/06	5/3/06	5/10/06
Matrix	Solid	Solid	Solid	Solid	Solid	Solid
Analyte/Methods (Units)						
Dioxins/Furans (Picogram/gram)						
1,2,3,4,6,7,8-Heptachlorodibenzo-p-dioxin	760	75	68	54	120	<13
1,2,3,4,6,7,8-Heptachlorodibenzofuran	940	87	94	54	170	<11
1,2,3,4,7,8,9-Heptachlorodibenzofuran	33 J	3.7 TJ	3.9 TJ	1.9 TJ	4.2 TJ	<9.7
1,2,3,4,7,8-Hexachlorodibenzo-p-dioxin	9.8 TJ	1.0 T	0.81 TJ	0.65 T	1.0 TJ	<12
1,2,3,4,7,8-Hexachlorodibenzofuran	200	28 J	22	16	37 J	<8.0
1,2,3,6,7,8-Hexachlorodibenzo-p-dioxin	52 J	7.5	5.2 T	4.4 T	7.3 TJ	<11
1,2,3,6,7,8-Hexachlorodibenzofuran	68 J	5.5 T	4.4 TJ	4.6 TJ	7.9 TJ	<7.4
1,2,3,7,8,9-Hexachlorodibenzo-p-dioxin	40 J	1.9 TJ	2.8 T	1.8 T	3.2 T	<11
1,2,3,7,8,9-Hexachlorodibenzofuran	<17	2.5 TJ	0.87 T	<7.2	<20	<8.3
1,2,3,7,8-Pentachlorodibenzo-p-dioxin	12 TJ	1.4 T	0.96 TJ	1.4 TJ	<20	<13
1,2,3,7,8-Pentachlorodibenzofuran	54 J	3.0 T	1.8 T	1.2 TJ	2.3 TJ	<8.3
2,3,4,6,7,8-Hexachlorodibenzofuran	25	3.0 T	3.0 TJ	1.8 T	4.8 T	<8.1
2,3,4,7,8-Pentachlorodibenzofuran	49	6.8 T	6.2 T	4.5 T	7.6 T	<8.0
2,3,7,8-Tetrachlorodibenzo-p-dioxin	430	58	42	63	57	<6.0
2,3,7,8-Tetrachlorodibenzofuran	23 J	6.3	4.1 J	4.1 J	4.0 J	<7.9
Octachlorodibenzo-p-dioxin	8400 B	630 B	580 B	450 B	1700 B	170 J
Octachlorodibenzofuran	920 J	85	120	52	140	<22

Bold Bolded result indicates positively identified compound.

B Analyte detected in an associated blank.

J Data are estimated due to associated quality control data.

T Analyte was positively identified but the reported concentration is estimated; reported concentration is less than the reporting limit, but greater than the method detection limit.

UB Analyte considered not detected based on associated blank data.

TABLE 8

DIOXINS/FURANS SOLID SAMPLE DATA SUMMARY
DEMONSTRATION TESTING AND FULL-SCALE OPERATION OF THE BIOGENESIS SEDIMENT DECONTAMINATION PROCESS
KEASBEY, NEW JERSEY
 (Page 23 of 25)

Field Sample Identification	SPC COMP-160506- 1700	SPP COMP-170506- 1030	MSL01-040107-0905	MSL02-040107-0925	MSL03-040107-0940	MSL04-040107-0950
Sediment Source	All	All	Lower Passaic River	Lower Passaic River	Lower Passaic River	Lower Passaic River
Location Identification	TSP	TSP	MSL	MSL	MSL	MSL
Date Collected	5/16/06	5/17/06	1/4/07	1/4/07	1/4/07	1/4/07
Matrix	Solid	Solid	Solid	Solid	Solid	Solid
Analyte/Methods (Units)						
Dioxins/Furans (Picogram/gram)						
1,2,3,4,6,7,8-Heptachlorodibenzo-p-dioxin	500	570	100 J	130 J	110 J	800 J
1,2,3,4,6,7,8-Heptachlorodibenzofuran	280	550	72 J	83 J	89 J	75 J
1,2,3,4,7,8,9-Heptachlorodibenzofuran	21	20	3.7 T	4.1 T	5.0	4.2 T
1,2,3,4,7,8-Hexachlorodibenzo-p-dioxin	6.5 J	8.1	1.1 T	1.4 T	1.4 T	2.7 T
1,2,3,4,7,8-Hexachlorodibenzofuran	64	160	20	24	22	18
1,2,3,6,7,8-Hexachlorodibenzo-p-dioxin	28	40	6.0	8.1	7.5	16
1,2,3,6,7,8-Hexachlorodibenzofuran	23	41	5.8	6.3	5.8	7.4
1,2,3,7,8,9-Hexachlorodibenzo-p-dioxin	15	21	0.36 T	5.2	3.8 T	11
1,2,3,7,8,9-Hexachlorodibenzofuran	<2.1	<2.4	0.57 T	0.84 T	<5.0	0.37 T
1,2,3,7,8-Pentachlorodibenzo-p-dioxin	6.2 J	10	1.2 T	1.5 T	1.4 T	1.1 T
1,2,3,7,8-Pentachlorodibenzofuran	17	17	2.3 T	3.0 T	2.4 T	3.1 T
2,3,4,6,7,8-Hexachlorodibenzofuran	17	20	2.7 T	3.6 T	3.2 T	4.5 T
2,3,4,7,8-Pentachlorodibenzofuran	22	42	5.3	6.7	6.7	5.4
2,3,7,8-Tetrachlorodibenzo-p-dioxin	64	390	42 J	50 J	47 J	21 J
2,3,7,8-Tetrachlorodibenzofuran	26	37	4.2	38	35	26
Octachlorodibenzo-p-dioxin	6600	5200	1400 JB	1700 JB	1500 JB	7600 JB
Octachlorodibenzofuran	490	820	100	110	110	86

- Bold** Bolded result indicates positively identified compound.
B Analyte detected in an associated blank.
J Data are estimated due to associated quality control data.
T Analyte was positively identified but the reported concentration is estimated; reported concentration is less than the reporting limit, but greater than the method detection limit.
UB Analyte considered not detected based on associated blank data.

TABLE 8

DIOXINS/FURANS SOLID SAMPLE DATA SUMMARY
DEMONSTRATION TESTING AND FULL-SCALE OPERATION OF THE BIOGENESIS SEDIMENT DECONTAMINATION PROCESS
KEASBEY, NEW JERSEY
 (Page 24 of 25)

Field Sample Identification	MSL05-040107-1000	MSL06-040107-1015	MSL07-040107-1025	MSL08-040107-1035	MSL09-040107-1045	MSL10-040107-1055
Sediment Source	Lower Passaic River	Lower Passaic River	Lower Passaic River	Lower Passaic River	Lower Passaic River	Lower Passaic River
Location Identification	MSL	MSL	MSL	MSL	MSL	MSL
Date Collected	1/4/07	1/4/07	1/4/07	1/4/07	1/4/07	1/4/07
Matrix	Solid	Solid	Solid	Solid	Solid	Solid
Analyte/Methods (Units)						
Dioxins/Furans (Picogram/gram)						
1,2,3,4,6,7,8-Heptachlorodibenzo-p-dioxin	46 J	160 J	130 J	56 J	81 J	120 J
1,2,3,4,6,7,8-Heptachlorodibenzofuran	36 J	120 J	110 J	45 J	68 J	75 J
1,2,3,4,7,8,9-Heptachlorodibenzofuran	2.2 TJ	6.5	5.6	2.5 T	2.2 T	3.9 T
1,2,3,4,7,8-Hexachlorodibenzo-p-dioxin	0.59 T	2.2 T	1.6 T	0.68 T	0.94 T	1.0 T
1,2,3,4,7,8-Hexachlorodibenzofuran	11	33	31	14	20	21
1,2,3,6,7,8-Hexachlorodibenzo-p-dioxin	3.5 T	11	6.9	4.5 T	5.9	6.8
1,2,3,6,7,8-Hexachlorodibenzofuran	2.6 T	9.5	6.5	4.2 T	6.1	5.2
1,2,3,7,8,9-Hexachlorodibenzo-p-dioxin	2.1 T	5.4	4.4 T	2.4 T	2.9 T	3.6 T
1,2,3,7,8,9-Hexachlorodibenzofuran	0.44 T	0.51 T	0.46 T	<5.0	1.1 T	0.35 T
1,2,3,7,8-Pentachlorodibenzo-p-dioxin	0.62 T	2.0 T	1.6 T	0.83 T	0.99 T	1.2 T
1,2,3,7,8-Pentachlorodibenzofuran	1.2 T	3.4 T	3.2 T	0.98 T	1.8 T	2.4 T
2,3,4,6,7,8-Hexachlorodibenzofuran	1.4 T	4.9 T	3.8 T	1.7 T	2.2 T	3.7 T
2,3,4,7,8-Pentachlorodibenzofuran	3.1 T	8.3	7.8	3.7 T	5.3	6.3
2,3,7,8-Tetrachlorodibenzo-p-dioxin	17 J	59 J	47 J	23 J	36 J	55 J
2,3,7,8-Tetrachlorodibenzofuran	17	7.7	5.6	3.0	4.0	4.6
Octachlorodibenzo-p-dioxin	690 JB	2400 JB	1700 JB	750 JB	970 JB	1200 JB
Octachlorodibenzofuran	220	160	150	54	79	87

Bold Bolded result indicates positively identified compound.

B Analyte detected in an associated blank.

J Data are estimated due to associated quality control data.

T Analyte was positively identified but the reported concentration is estimated; reported concentration is less than the reporting limit, but greater than the method detection limit.

UB Analyte considered not detected based on associated blank data.

TABLE 8

DIOXINS/FURANS SOLID SAMPLE DATA SUMMARY
DEMONSTRATION TESTING AND FULL-SCALE OPERATION OF THE BIOGENESIS SEDIMENT DECONTAMINATION PROCESS
KEASBEY, NEW JERSEY
 (Page 25 of 25)

Field Sample Identification	MSL11-040107-1055	TS1-121908-0800	AD1-121908-0830	AD2-121908-0820	AD3-121908-0840	MS-121908-0850
Sediment Source	Lower Passaic River	Lower Passaic River	None	None	None	Lower Passaic River
Location Identification	MSL	TS	AD	AD	AD	MSL
Date Collected	1/4/07	12/19/08	12/19/08	12/19/08	12/19/08	12/19/08
Matrix	Solid	Solid	Solid	Solid	Solid	Solid
Analyte/Methods (Units)						
Dioxins/Furans (Picogram/gram)						
1,2,3,4,6,7,8-Heptachlorodibenzo-p-dioxin	45 J	150	<5.0	7.9	1.4 QJ	77
1,2,3,4,6,7,8-Heptachlorodibenzofuran	36 J	92	0.58 J	0.21 J	<22	77
1,2,3,4,7,8,9-Heptachlorodibenzofuran	1.5 T	5.8 B	<5.0	<5.0	<22	4.1 J
1,2,3,4,7,8-Hexachlorodibenzo-p-dioxin	0.49 T	1.9 J	<5.0	<5.0	<22	0.88 QJ
1,2,3,4,7,8-Hexachlorodibenzofuran	11	26	<5.0	<5.0	<22	18
1,2,3,6,7,8-Hexachlorodibenzo-p-dioxin	3.1 T	8.2	<5.0	0.22 QJ	<22	4.2 QJ
1,2,3,6,7,8-Hexachlorodibenzofuran	3.7 T	8.9 Q	<5.0	<5.0	<22	4.6 QJ
1,2,3,7,8,9-Hexachlorodibenzo-p-dioxin	1.8 T	6.5	<5.0	0.25 QJ	<22	1.7 QJ
1,2,3,7,8,9-Hexachlorodibenzofuran	<5.0	0.91 QBJ	<5.0	<5.0	<22	<5.0
1,2,3,7,8-Pentachlorodibenzo-p-dioxin	0.57 T	7.0 Q	<5.0	<5.0	<22	<5.0
1,2,3,7,8-Pentachlorodibenzofuran	1.3 T	3.3 QJ	<5.0	<5.0	<22	2.1 J
2,3,4,6,7,8-Hexachlorodibenzofuran	1.2 T	4.9 J	<5.0	<5.0	<22	2.1 J
2,3,4,7,8-Pentachlorodibenzofuran	3.1 T	7.9	<5.0	<5.0	<22	3.6 QJ
2,3,7,8-Tetrachlorodibenzo-p-dioxin	20 J	37	<1.0	<1.0	<4.4	18
2,3,7,8-Tetrachlorodibenzofuran	2.5	17	<1.0	<1.0	<4.4	9.7 Q
Octachlorodibenzo-p-dioxin	550 JB	2500 B	2.2 J	800	24 QJ	1600
Octachlorodibenzofuran	59	99	0.75 QJ	0.48 QJ	<44	130

- Bold** Bolded result indicates positively identified compound.
B Analyte detected in an associated blank.
J Data are estimated due to associated quality control data.
T Analyte was positively identified but the reported concentration is estimated; reported concentration is less than the reporting limit, but greater than the method detection limit.
UB Analyte considered not detected based on associated blank data.

TABLE 9
METALS SOLID SAMPLE DATA SUMMARY
DEMONSTRATION TESTING AND FULL-SCALE OPERATION OF THE BIOGENESIS SEDIMENT DECONTAMINATION PROCESS
KEASBEY, NEW JERSEY
 (Page 1 of 58)

Field Sample Identification	BAY-1	RS-211205-1000	TS-211205-1715	WS1-211205-1800	TS-291205-1100	WS-291205-1110	RS-030106-1600
Sediment Source	Raritan River	Raritan River	Raritan River	Raritan River	Raritan River	Raritan River	Raritan River
Location Identification	PPS	RS	TS	WS	TS	WS	RS
Date Collected	11/23/05	12/21/05	12/21/05	12/21/05	12/29/05	12/29/05	1/3/06
Matrix	Solid	Solid	Solid	Solid	Solid	Solid	Solid
Analyte/Methods (Units)							
Metals/SW6010B (mg/kg)							
Antimony	-	-	-	-	-	-	-
Arsenic	23.6	23.6	24.9	63.8	24.6	59.8	27.9
Barium	79.7	60.8	82.4	143	83.7	140	82.6
Beryllium	-	-	-	-	-	-	-
Cadmium	<0.99	0.27 T	0.35 T	0.9 T	<0.73	<1.6	0.6 T
Chromium III	-	-	-	-	-	-	-
Chromium, Total	43.5	27.3 B	28.6 B	84.6 B	26.4 B	83.3 B	34.7
Copper	-	-	-	-	-	-	-
Lead	76.9	59.6	54.4	190	55 B	178 B	76.9
Mercury/SW7471A	1.2 J	0.88	0.76	1.9	0.8	1.8	1.0
Nickel	27.6	20.8	59.6	84.5	35.2	58.6	25.9
Selenium	1.5	1.3 T	1.7	4.5	1.6	4.0	4.7
Silver	0.51 T	0.48 T	0.51 T	1.5 T	0.44 T	1.4 T	0.49 T
Thallium	-	-	-	-	-	-	-
Vanadium	-	-	-	-	-	-	-
Zinc	163 J	125 B	134 B	354 B	131 JB	321 B	151 JB

mg/kg milligrams per kilogram.
Bold Bolded result indicates positively identified compound.
 - Not analyzed.
 B Analyte detected in an associated blank.
 D Sample dilution required for analysis; reported values reflect the dilution.
 J Data are estimated due to associated quality control data.
 T Analyte was positively identified but the reported concentration is estimated; reported concentration is less than the reporting limit, but greater than the method detection limit.

TABLE 9

METALS SOLID SAMPLE DATA SUMMARY
DEMONSTRATION TESTING AND FULL-SCALE OPERATION OF THE BIOGENESIS SEDIMENT DECONTAMINATION PROCESS
KEASBEY, NEW JERSEY
 (Page 2 of 58)

Field Sample Identification	TS-030106-1645	WS1-030106-1615	WS2-030106-1630	RS-040106-1300	TS-040106-1100	WS-040106-1400	RS-050106-1500
Sediment Source	Raritan River	Raritan River	Raritan River	Raritan River	Raritan River	Raritan River	Raritan River
Location Identification	TS	WS1	WS2	RS	TS	WS	RS
Date Collected	1/3/06	1/3/06	1/3/06	1/4/06	1/4/06	1/4/06	1/5/06
Matrix	Solid	Solid	Solid	Solid	Solid	Solid	Solid
Analyte/Methods (Units)							
Metals/SW6010B (mg/kg)							
Antimony	-	-	-	-	-	-	-
Arsenic	19.4	61.6	52.9	45.1	36.2	59.4	39.8
Barium	72.3	139	142	178	95.8	140	108
Beryllium	-	-	-	-	-	-	-
Cadmium	0.48 T	1.5 T	1.5	1.0 T	0.55 T	1.1 T	<1.5
Chromium III	-	-	-	-	-	-	-
Chromium, Total	21.1	83.3	84.5	55.2	26.3	83.8	48.2 B
Copper	-	-	-	-	-	-	-
Lead	48.2	179	156	119	66.1	179	100
Mercury/SW7471A	0.7	1.9	1.5	0.95	0.77	1.9	0.99
Nickel	35.1	57.4	249	45.1	28	54.4	36.1
Selenium	1.2	4.6	3.8	3.7	2.0	4.7	2.6
Silver	0.3 T	1.3 T	1.2 T	0.89 T	0.56 T	1.4 T	0.89 T
Thallium	-	-	-	-	-	-	-
Vanadium	-	-	-	-	-	-	-
Zinc	104 B	328 B	312 B	249 B	140 B	329 B	206 B

mg/kg milligrams per kilogram.

Bold Bolded result indicates positively identified compound.

- Not analyzed.

B Analyte detected in an associated blank.

D Sample dilution required for analysis; reported values reflect the dilution.

J Data are estimated due to associated quality control data.

T Analyte was positively identified but the reported concentration is estimated; reported concentration is less than the reporting limit, but greater than the method detection limit.

TABLE 9
METALS SOLID SAMPLE DATA SUMMARY
DEMONSTRATION TESTING AND FULL-SCALE OPERATION OF THE BIOGENESIS SEDIMENT DECONTAMINATION PROCESS
KEASBEY, NEW JERSEY
(Page 3 of 58)

Field Sample Identification	TS-050106-1505	WS-050106-1510	RS-060106-1531	TS-060106-1532	WS-060106-1533	RS-090106-1500	TS-090106-1501
Sediment Source	Raritan River	Raritan River	Raritan River	Raritan River	Raritan River	Raritan River	Raritan River
Location Identification	TS	WS	RS	TS	WS	RS	TS
Date Collected	1/5/06	1/5/06	1/6/06	1/6/06	1/6/06	1/9/06	1/9/06
Matrix	Solid	Solid	Solid	Solid	Solid	Solid	Solid
Analyte/Methods (Units)							
Metals/SW6010B (mg/kg)							
Antimony	-	-	-	-	-	-	-
Arsenic	25.9	58.6	144	25.7	60.2	49.7	25.1
Barium	92.8	136	392	85.7	135	131	78.8
Beryllium	-	-	-	-	-	-	-
Cadmium	<0.75	<1.4	<6.1	<0.79	<1.4	0.79 T	0.39 T
Chromium III	-	-	-	-	-	-	-
Chromium, Total	29.7 B	80.2 B	183 B	28.8 B	80.9 B	60.9	26
Copper	-	-	-	-	-	-	-
Lead	59	178	380	63.9	180	131	52.8
Mercury/SW7471A	0.85	1.9	1.2	1.7	1.8	1.1	0.8
Nickel	30.1	51.5	134	27.2	49.9	43.2	25.7
Selenium	1.7	4.1	8.6	1.9	3.9	2.6	1.3
Silver	0.49 T	1.9	3.1 T	0.47 T	1.5	1.2 T	0.5 T
Thallium	-	-	-	-	-	-	-
Vanadium	-	-	-	-	-	-	-
Zinc	142 B	321 B	773 JB	138 B	326 B	262 JB	128 B

mg/kg milligrams per kilogram.
Bold Bolded result indicates positively identified compound.
- Not analyzed.
B Analyte detected in an associated blank.
D Sample dilution required for analysis; reported values reflect the dilution.
J Data are estimated due to associated quality control data.
T Analyte was positively identified but the reported concentration is estimated; reported concentration is less than the reporting limit, but greater than the method detection limit.

TABLE 9
METALS SOLID SAMPLE DATA SUMMARY
DEMONSTRATION TESTING AND FULL-SCALE OPERATION OF THE BIOGENESIS SEDIMENT DECONTAMINATION PROCESS
KEASBEY, NEW JERSEY
 (Page 4 of 58)

Field Sample Identification	WS-090106-1502	RS-100106-1600	TS-100106-1601	WS-100106-1602	RS-110106-1630	TS-110106-1631	RS-120106-1630
Sediment Source	Raritan River	Raritan River	Raritan River	Raritan River	Raritan River	Raritan River	Raritan River
Location Identification	WS	RS	TS	WS	RS	TS	RS
Date Collected	1/9/06	1/10/06	1/10/06	1/10/06	1/11/06	1/11/06	1/12/06
Matrix	Solid	Solid	Solid	Solid	Solid	Solid	Solid
Analyte/Methods (Units)							
Metals/SW6010B (mg/kg)							
Antimony	-	-	-	-	-	-	-
Arsenic	59.4	44.3	28.7	46.6	31.7	37	53.8
Barium	135	218 B	82.5 B	116 B	89 B	88.4 B	137 B
Beryllium	-	-	-	-	-	-	-
Cadmium	1.1 T	0.83 T	0.6 T	0.94 T	0.65 T	0.79 T	0.97 T
Chromium III	-	-	-	-	-	-	-
Chromium, Total	83	52.1	24.9	59.2	38.3	42.2	65.2
Copper	-	-	-	-	-	-	-
Lead	173	112	74.2	129	83.2	93.2	141
Mercury/SW7471A	1.8	1.3	0.32	1.5	1.1	0.94	1.4
Nickel	50.1	37.9	58.7	40	28.8	35.1	47.1
Selenium	2.7	43.6	1.8	4.0	2.8	2.6	5.0
Silver	1.5	0.88 T	0.3 T	1.0 T	0.62 T	2.1	1.2 T
Thallium	-	-	-	-	-	-	-
Vanadium	-	-	-	-	-	-	-
Zinc	326 B	240 B	144 B	246 B	166 B	192 B	281 JB

mg/kg milligrams per kilogram.
Bold Bolded result indicates positively identified compound.
 - Not analyzed.
 B Analyte detected in an associated blank.
 D Sample dilution required for analysis; reported values reflect the dilution.
 J Data are estimated due to associated quality control data.
 T Analyte was positively identified but the reported concentration is estimated; reported concentration is less than the reporting limit, but greater than the method detection limit.

TABLE 9

METALS SOLID SAMPLE DATA SUMMARY
DEMONSTRATION TESTING AND FULL-SCALE OPERATION OF THE BIOGENESIS SEDIMENT DECONTAMINATION PROCESS
KEASBEY, NEW JERSEY
 (Page 5 of 58)

Field Sample Identification	TS-120106-1601	WS-120106-1602	RS-190106-1600	TS-190106-1601	WS-190106-1602	RS-240106-1530	TS-240106-1630
Sediment Source	Raritan River	Raritan River	Lower Passaic River	Lower Passaic River	Lower Passaic River	Lower Passaic River	Lower Passaic River
Location Identification	TS	WS	RS	TS	WS	RS	TS
Date Collected	1/12/06	1/12/06	1/19/06	1/19/06	1/19/06	1/24/06	1/24/06
Matrix	Solid	Solid	Solid	Solid	Solid	Solid	Solid
Analyte/Methods (Units)							
Metals/SW6010B (mg/kg)							
Antimony	-	-	-	-	-	-	-
Arsenic	33.3	56.4	11	13.6	41	12.8	6.5
Barium	79.9 B	126 B	124	133	257	216	114
Beryllium	-	-	-	-	-	-	-
Cadmium	0.67 T	0.98 T	4.6	4.1	9.6	7.5	3.3
Chromium III	-	-	-	-	-	-	-
Chromium, Total	36.7	72.8	125 J	111	311	204	77.6
Copper	-	-	-	-	-	-	-
Lead	62.7	162	261 J	307	498	404 J	199
Mercury/SW7471A	0.66	1.8	5.6	2.8	6.5	4.8	2.4
Nickel	42.6	46.3	36.3	46.5	72.5	52.9	31.3
Selenium	2.5	4.2	1.9 T	2.5	4.2	2.8	1.3
Silver	0.55 T	1.3 T	4.0	3.0	9.9	7.4	3.1
Thallium	-	-	-	-	-	-	-
Vanadium	-	-	-	-	-	-	-
Zinc	151 B	298 B	462 J	484	999	755 B	335 B

mg/kg milligrams per kilogram.

Bold Bolded result indicates positively identified compound.

- Not analyzed.

B Analyte detected in an associated blank.

D Sample dilution required for analysis; reported values reflect the dilution.

J Data are estimated due to associated quality control data.

T Analyte was positively identified but the reported concentration is estimated; reported concentration is less than the reporting limit, but greater than the method detection limit.

TABLE 9

METALS SOLID SAMPLE DATA SUMMARY
DEMONSTRATION TESTING AND FULL-SCALE OPERATION OF THE BIOGENESIS SEDIMENT DECONTAMINATION PROCESS
KEASBEY, NEW JERSEY
 (Page 6 of 58)

Field Sample Identification	RS-270106-1400	TS-270106-1401	TS-270106-1530	WS-270106-1402	WS-270106-1531	RS-300106-1700	WS2-300106-1702
Sediment Source	Lower Passaic River	Lower Passaic River	Lower Passaic River	Lower Passaic River	Lower Passaic River	Raritan River	Raritan River
Location Identification	RS	TS	TS	WS	WS	RS	WS2
Date Collected	1/27/06	1/27/06	1/27/06	1/27/06	1/27/06	1/30/06	1/30/06
Matrix	Solid	Solid	Solid	Solid	Solid	Solid	Solid
Analyte/Methods (Units)							
Metals/SW6010B (mg/kg)							
Antimony	-	-	-	-	-	-	-
Arsenic	9.8	4.9	6.2	21.1	20.3	37.2	11.5
Barium	169	79	110	328	337	133	166
Beryllium	-	-	-	-	-	-	-
Cadmium	6.2	2.7	3.5	14.1	14.8	1.8	5.8
Chromium III	-	-	-	-	-	-	-
Chromium, Total	158	56.6	72.5	405	408	87.7 J	164
Copper	-	-	-	-	-	-	-
Lead	320 J	184	229	637	646	179	303
Mercury/SW7471A	3.7	1.3	2.3	8.5	8.6	2.1	4.2
Nickel	43.4 J	32.6	32.6	75.5	70.7	41.6	43.1
Selenium	1.9	1.9	1.5	3.7	4.0	1.9	1.1
Silver	5.7	1.5	2.3	15.1	15.4	2.4	6.2
Thallium	-	-	-	-	-	-	-
Vanadium	-	-	-	-	-	-	-
Zinc	596 JB	255 B	355 B	1280 B	1330 B	352 JB	574 JB

mg/kg milligrams per kilogram.

Bold Bolded result indicates positively identified compound.

- Not analyzed.

B Analyte detected in an associated blank.

D Sample dilution required for analysis; reported values reflect the dilution.

J Data are estimated due to associated quality control data.

T Analyte was positively identified but the reported concentration is estimated; reported concentration is less than the reporting limit, but greater than the method detection limit.

TABLE 9
METALS SOLID SAMPLE DATA SUMMARY
DEMONSTRATION TESTING AND FULL-SCALE OPERATION OF THE BIOGENESIS SEDIMENT DECONTAMINATION PROCESS
KEASBEY, NEW JERSEY
 (Page 7 of 58)

Field Sample Identification	RS-310106-1700	TS-310106-1701	WS-310106-1702	RS-010206-1600	TS-010206-1601	WS-010206-1602	RS-020206-1800
Sediment Source	Raritan River	Raritan River	Raritan River	Raritan River	Raritan River	Raritan River	Raritan River
Location Identification	RS	TS	WS	RS	TS	WS	RS
Date Collected	1/31/06	1/31/06	1/31/06	2/1/06	2/1/06	2/1/06	2/2/06
Matrix	Solid	Solid	Solid	Solid	Solid	Solid	Solid
Analyte/Methods (Units)							
Metals/SW6010B (mg/kg)							
Antimony	-	-	-	-	-	-	-
Arsenic	87.4	26.2 J	56.7	64.7	28	44.4	74.9
Barium	225	81.7 J	142	170	99.8	135	200
Beryllium	-	-	-	-	-	-	-
Cadmium	1.9 T	0.78	1.1	1.5	0.61	3.0	2.2
Chromium III	-	-	-	-	-	-	-
Chromium, Total	112	39.8 J	96.8	75.3	25.8	108	89.1
Copper	-	-	-	-	-	-	-
Lead	232	56.1 J	181	162	63.3	207	192
Mercury/SW7471A	1.0	1.0	1.9	1.4	0.89	2.7	1.8 J
Nickel	79.9	33.8 J	44.4	50.3	22.1	43.5	60.4
Selenium	7.5	2.2 J	4.4	5.2	1.8	3.4	5.4
Silver	2.3 T	1.1 J	2.0	1.6	0.53	3.0	1.9
Thallium	-	-	-	-	-	-	-
Vanadium	-	-	-	-	-	-	-
Zinc	464 B	127 JB	217 B	301 B	112 B	480 B	364 B

mg/kg milligrams per kilogram.

Bold Bolded result indicates positively identified compound.

- Not analyzed.

B Analyte detected in an associated blank.

D Sample dilution required for analysis; reported values reflect the dilution.

J Data are estimated due to associated quality control data.

T Analyte was positively identified but the reported concentration is estimated; reported concentration is less than the reporting limit, but greater than the method detection limit.

TABLE 9

METALS SOLID SAMPLE DATA SUMMARY
DEMONSTRATION TESTING AND FULL-SCALE OPERATION OF THE BIOGENESIS SEDIMENT DECONTAMINATION PROCESS
KEASBEY, NEW JERSEY
 (Page 8 of 58)

Field Sample Identification	TS-020206-1801	WS-020206-1802	RS-030206-1200	TS-030206-1201	WS-030206-1202	RS-060206-1930	TS-060206-1931
Sediment Source	Raritan River	Raritan River	Raritan River	Raritan River	Raritan River	Raritan River	Raritan River
Location Identification	TS	WS	RS	TS	WS	RS	TS
Date Collected	2/2/06	2/2/06	2/3/06	2/3/06	2/3/06	2/6/06	2/6/06
Matrix	Solid	Solid	Solid	Solid	Solid	Solid	Solid
Analyte/Methods (Units)							
Metals/SW6010B (mg/kg)							
Antimony	-	-	-	-	-	-	-
Arsenic	33.5 J	58	40.6	33.7	70.8	50.3	29.2 J
Barium	99.9 J	126	108	98.6	141	121	94.3
Beryllium	-	-	-	-	-	-	-
Cadmium	0.88	2.6	1.1	0.84	1.8	1.3	0.76
Chromium III	-	-	-	-	-	-	-
Chromium, Total	31.7 J	87.4	47.3	29.8	95.8	53.7	26.8 J
Copper	-	-	-	-	-	-	-
Lead	70.7 J	213	106	67.5	196	118	61.8 J
Mercury/SW7471A	1.1	2.6	1.2	0.96	2.7	1.2	1.2
Nickel	26.4 J	47.2	33.1	27	46.7	37	23.6 J
Selenium	2.1	3.6	2.8	2.1	5.3	3.4	1.8
Silver	0.7	1.9	0.97	0.6	1.9	1.1	0.55
Thallium	-	-	-	-	-	-	-
Vanadium	-	-	-	-	-	-	-
Zinc	133 JB	496 B	191 B	135 B	297 B	234 B	124 JB

mg/kg milligrams per kilogram.

Bold Bolded result indicates positively identified compound.

- Not analyzed.

B Analyte detected in an associated blank.

D Sample dilution required for analysis; reported values reflect the dilution.

J Data are estimated due to associated quality control data.

T Analyte was positively identified but the reported concentration is estimated; reported concentration is less than the reporting limit, but greater than the method detection limit.

TABLE 9

METALS SOLID SAMPLE DATA SUMMARY
DEMONSTRATION TESTING AND FULL-SCALE OPERATION OF THE BIOGENESIS SEDIMENT DECONTAMINATION PROCESS
KEASBEY, NEW JERSEY
 (Page 9 of 58)

Field Sample Identification	WS-060206-1932	SP-070206-1445	RS-070206-1630	TS-070206-1631	TS-070206-1631 DRIED	WS-070206-1632	RS-080206-1700
Sediment Source	Raritan River	Raritan River	Raritan River	Raritan River	Raritan River	Raritan River	Raritan River
Location Identification	WS	PPS	RS	TS	TS	WS	RS
Date Collected	2/6/06	2/7/06	2/7/06	2/7/06	2/7/06	2/7/06	2/8/06
Matrix	Solid	Solid	Solid	Solid	Solid	Solid	Solid
Analyte/Methods (Units)							
Metals/SW6010B (mg/kg)							
Antimony	-	-	-	-	-	-	-
Arsenic	65.1	33.5	44.5	31.5	32.1	65	39
Barium	127	335	108	93.5	91.4	128	103
Beryllium	-	-	-	-	-	-	-
Cadmium	2.4	5.9	1.1	0.79	0.61	2.1	1.2
Chromium III	-	-	-	-	-	-	-
Chromium, Total	84.5	174	49.7	29.8	28.4	86.3	41.5
Copper	-	-	-	-	-	-	-
Lead	201	232	109	74.2	65.7	192	94
Mercury/SW7471A	2.7	7.0	1.3	1.2	1.1	2.7	1.3
Nickel	43.1	38.1	34.1	28.2	24.8	47.3	29.7
Selenium	4.1	2.5	3.2	2.0	1.6	4.1	3.0
Silver	1.8	3.5	1.0	0.69	0.62	1.8	0.83
Thallium	-	-	-	-	-	-	-
Vanadium	-	-	-	-	-	-	-
Zinc	521 B	348 B	208 B	137 B	136	340 B	174 B

mg/kg milligrams per kilogram.

Bold Bolded result indicates positively identified compound.

- Not analyzed.

B Analyte detected in an associated blank.

D Sample dilution required for analysis; reported values reflect the dilution.

J Data are estimated due to associated quality control data.

T Analyte was positively identified but the reported concentration is estimated; reported concentration is less than the reporting limit, but greater than the method detection limit.

TABLE 9

METALS SOLID SAMPLE DATA SUMMARY
DEMONSTRATION TESTING AND FULL-SCALE OPERATION OF THE BIOGENESIS SEDIMENT DECONTAMINATION PROCESS
KEASBEY, NEW JERSEY
 (Page 10 of 58)

Field Sample Identification	TS-080206-1701	WS-080206-1702	RS-090206-2300	TS-090206-2301	WS-090206-2302	RS-130206-1700	TS-130206-1701
Sediment Source	Raritan River	Raritan River	Arthur Kill	Arthur Kill	Arthur Kill	Lower Passaic River	Lower Passaic River
Location Identification	TS	WS	RS	TS	WS	RS	TS
Date Collected	2/8/06	2/8/06	2/9/06	2/9/06	2/9/06	2/13/06	2/13/06
Matrix	Solid	Solid	Solid	Solid	Solid	Solid	Solid
Analyte/Methods (Units)							
Metals/SW6010B (mg/kg)							
Antimony	-	-	-	-	-	-	-
Arsenic	34 J	67.9	33.3	28.7	67.9	13.9	10.8 J
Barium	100 J	137	307	239	225	204	150
Beryllium	-	-	-	-	-	-	-
Cadmium	1.3 J	2.3	4.9	2.3	6.5	7.6	1.9
Chromium III	-	-	-	-	-	-	-
Chromium, Total	31.8 J	88.2	150	66.2	218	232	52.5
Copper	-	-	-	-	-	-	-
Lead	72 J	194	214 J	125	307	425	129
Mercury/SW7471A	1.2	2.6	6.3	3.1	9.3	5.5 J	2.1 J
Nickel	28.1 J	47.4	41.3 J	34.2	53.3	55.8	25.1
Selenium	2.0	5.4	2.9	2.4	4.9	3.3	1.3
Silver	3.7 J	1.8	3.2	1.6	4.4	7.5	1.3 J
Thallium	-	-	-	-	-	-	-
Vanadium	-	-	-	-	-	-	-
Zinc	148 JB	316 B	338 JB	199 B	492 B	810 B	200 JB

mg/kg milligrams per kilogram.

Bold Bolded result indicates positively identified compound.

- Not analyzed.

B Analyte detected in an associated blank.

D Sample dilution required for analysis; reported values reflect the dilution.

J Data are estimated due to associated quality control data.

T Analyte was positively identified but the reported concentration is estimated; reported concentration is less than the reporting limit, but greater than the method detection limit.

TABLE 9

METALS SOLID SAMPLE DATA SUMMARY
DEMONSTRATION TESTING AND FULL-SCALE OPERATION OF THE BIOGENESIS SEDIMENT DECONTAMINATION PROCESS
KEASBEY, NEW JERSEY
 (Page 11 of 58)

Field Sample Identification	WS-130206-1702	RS-140206-1330	TS-140206-1331	WS-140206-1332	RS-160206-1500	TS-160206-1501	WS-160206-1502
Sediment Source	Lower Passaic River	Arthur Kill	Arthur Kill	Arthur Kill	Arthur Kill	Arthur Kill	Arthur Kill
Location Identification	WS	RS	TS	WS	RS	TS	WS
Date Collected	2/13/06	2/14/06	2/14/06	2/14/06	2/16/06	2/16/06	2/16/06
Matrix	Solid	Solid	Solid	Solid	Solid	Solid	Solid
Analyte/Methods (Units)							
Metals/SW6010B (mg/kg)							
Antimony	-	-	-	-	-	-	-
Arsenic	60.7	36.9	10.8	48.9	27.8	20.1	50.8
Barium	355	367	202	323	265	263	310
Beryllium	-	-	-	-	-	-	-
Cadmium	9.3	5.8	1.4	10.3	4.3	2.2	9.7
Chromium III	-	-	-	-	-	-	-
Chromium, Total	394	211	58.6	401	166	76.3	348
Copper	-	-	-	-	-	-	-
Lead	491	311	154	507	231	146	437
Mercury/SW7471A	18.9 J	8.3 J	2.7 J	16 J	5.7	3.4	14.2
Nickel	66.7	56.3	29.1	99.3	41	36.2	57.9
Selenium	5.9	2.9 J	0.85	3.7	2.2	1.6	3.2
Silver	8.5	5.0 B	0.87 B	10 B	3.7 B	2.0 B	8.1 B
Thallium	-	-	-	-	-	-	-
Vanadium	-	-	-	-	-	-	-
Zinc	733 B	493 JB	168 B	766 B	389 B	231 B	676 B

mg/kg milligrams per kilogram.

Bold Bolded result indicates positively identified compound.

- Not analyzed.

B Analyte detected in an associated blank.

D Sample dilution required for analysis; reported values reflect the dilution.

J Data are estimated due to associated quality control data.

T Analyte was positively identified but the reported concentration is estimated; reported concentration is less than the reporting limit, but greater than the method detection limit.

TABLE 9

METALS SOLID SAMPLE DATA SUMMARY
DEMONSTRATION TESTING AND FULL-SCALE OPERATION OF THE BIOGENESIS SEDIMENT DECONTAMINATION PROCESS
KEASBEY, NEW JERSEY
 (Page 12 of 58)

Field Sample Identification	RS-170206-1100	TS-170206-1101	WS-170206-1102	TS-230206-0930	TS-230206-0930 DRIED	RS-270206-1400	TS-270206-1350
Sediment Source	Arthur Kill	Arthur Kill	Arthur Kill	Arthur Kill	Arthur Kill	Lower Passaic River	Lower Passaic River
Location Identification	RS	TS	WS	TS	TS	RS	TS
Date Collected	2/17/06	2/17/06	2/17/06	2/23/06	2/23/06	2/27/06	2/27/06
Matrix	Solid	Solid	Solid	Solid	Solid	Solid	Solid
Analyte/Methods (Units)							
Metals/SW6010B (mg/kg)							
Antimony	-	-	-	-	-	-	-
Arsenic	47.2	17.8	58.7 J	18.6	21.9	16	18.6
Barium	456 J	238	368	260	261	216	245
Beryllium	-	-	-	-	-	-	-
Cadmium	8.5	2.8	12.6	2.0	2.0	5.3	2.7
Chromium III	-	-	-	-	-	-	-
Chromium, Total	270	74.1	423	69	63.4	171	78.7
Copper	-	-	-	-	-	-	-
Lead	395 J	133	506	145	142	342	151 J
Mercury/SW7471A	7.3	2.7	15.6	2.9	3.0	4.1	3.2
Nickel	71.9	35.1	67.2	35.2	35.4	46.5	35.1
Selenium	6.2	1.3	4.1	1.3 J	1.3	2.5	2.5 J
Silver	7.9 J	1.8	9.6	2.0	1.5	4.8	2.1
Thallium	-	-	-	-	-	-	-
Vanadium	-	-	-	-	-	-	-
Zinc	629	215	803 J	212 J	204	536	233 J

mg/kg milligrams per kilogram.

Bold Bolded result indicates positively identified compound.

- Not analyzed.

B Analyte detected in an associated blank.

D Sample dilution required for analysis; reported values reflect the dilution.

J Data are estimated due to associated quality control data.

T Analyte was positively identified but the reported concentration is estimated; reported concentration is less than the reporting limit, but greater than the method detection limit.

TABLE 9

METALS SOLID SAMPLE DATA SUMMARY
DEMONSTRATION TESTING AND FULL-SCALE OPERATION OF THE BIOGENESIS SEDIMENT DECONTAMINATION PROCESS
KEASBEY, NEW JERSEY
 (Page 13 of 58)

Field Sample Identification	TS-270206-1350 DRIED	TS-270206-1630	TS-270206-1630 DRIED	RS-280206-1700	TS-280206-1705	WS-280206-1710	RS-010306-1700
Sediment Source	Lower Passaic River	Lower Passaic River	Lower Passaic River	Arthur Kill	Arthur Kill	Arthur Kill	Arthur Kill
Location Identification	TS	TS	TS	RS	TS	WS	RS
Date Collected	2/27/06	2/27/06	2/27/06	2/28/06	2/28/06	2/28/06	3/1/06
Matrix	Solid	Solid	Solid	Solid	Solid	Solid	Solid
Analyte/Methods (Units)							
Metals/SW6010B (mg/kg)							
Antimony	-	-	-	-	-	-	-
Arsenic	13.8	13.2	11.8	26.6	18.5	51.1	29.8
Barium	190	198	175	282	294	349	297
Beryllium	-	-	-	-	-	-	-
Cadmium	2.3	2.7	2.3	4.4	1.9	10.2	4.6
Chromium III	-	-	-	-	-	-	-
Chromium, Total	70.4	77.6	65.4	168	75.8	405	178
Copper	-	-	-	-	-	-	-
Lead	129	175	162	218	146	480	263 J
Mercury/SW7471A	3.4	3.8	3.5	7.1	3.7	15.3	9.3
Nickel	32.2	34.1	31.1	47	45.1	74	53.5
Selenium	1.8	1.9	1.7	3.0	2.4	5.4	2.8 J
Silver	1.4	2.0	1.6	3.9	5.4	10	4.6 JB
Thallium	-	-	-	-	-	-	-
Vanadium	-	-	-	-	-	-	-
Zinc	192	264	232	358	218	743	395 JB

mg/kg milligrams per kilogram.

Bold Bolded result indicates positively identified compound.

- Not analyzed.

B Analyte detected in an associated blank.

D Sample dilution required for analysis; reported values reflect the dilution.

J Data are estimated due to associated quality control data.

T Analyte was positively identified but the reported concentration is estimated; reported concentration is less than the reporting limit, but greater than the method detection limit.

TABLE 9

METALS SOLID SAMPLE DATA SUMMARY
DEMONSTRATION TESTING AND FULL-SCALE OPERATION OF THE BIOGENESIS SEDIMENT DECONTAMINATION PROCESS
KEASBEY, NEW JERSEY
 (Page 14 of 58)

Field Sample Identification	TS-010306-1705	WS-010306-1710	SS-020306-1400	RS-020306-1700	TS-020306-1705	WS-020306-1710	RS-030306-1200
Sediment Source	Arthur Kill	Arthur Kill	Arthur Kill	Arthur Kill	Arthur Kill	Arthur Kill	Arthur Kill
Location Identification	TS	WS	SS1	RS	TS	WS	RS
Date Collected	3/1/06	3/1/06	3/2/06	3/2/06	3/2/06	3/2/06	3/3/06
Matrix	Solid	Solid	Solid	Solid	Solid	Solid	Solid
Analyte/Methods (Units)							
Metals/SW6010B (mg/kg)							
Antimony	-	-	-	-	-	-	-
Arsenic	21.4	50.6	34.3	35.6	22.6	47.4	33.3
Barium	272	318	116	371	300	317	347
Beryllium	-	-	-	-	-	-	-
Cadmium	2.6	9.6	2.1	6.1	3.3	10.1	5.9
Chromium III	-	-	-	-	-	-	-
Chromium, Total	98	361	100	222	106	368	210
Copper	-	-	-	-	-	-	-
Lead	174	446	127	303 J	181	433	285 J
Mercury/SW7471A	4.4	14.2	3.2	7.2	4.9	14	9.0
Nickel	46.7	69.6	24.1	63.8	46.9	63.7	60.5
Selenium	1.9	3.9	1.2	2.5 J	1.7	3.3	2.2
Silver	2.6 B	9.2 B	1.5 B	6.0 B	3.0 B	9.3 B	5.3
Thallium	-	-	-	-	-	-	-
Vanadium	-	-	-	-	-	-	-
Zinc	260 B	703 B	186 B	482 B	282 B	668 B	456 JB

mg/kg milligrams per kilogram.

Bold Bolded result indicates positively identified compound.

- Not analyzed.

B Analyte detected in an associated blank.

D Sample dilution required for analysis; reported values reflect the dilution.

J Data are estimated due to associated quality control data.

T Analyte was positively identified but the reported concentration is estimated; reported concentration is less than the reporting limit, but greater than the method detection limit.

TABLE 9

METALS SOLID SAMPLE DATA SUMMARY
DEMONSTRATION TESTING AND FULL-SCALE OPERATION OF THE BIOGENESIS SEDIMENT DECONTAMINATION PROCESS
KEASBEY, NEW JERSEY
 (Page 15 of 58)

Field Sample Identification	TS-030306-1205	WS-030306-1210	SEC SCREEN- INFLUENT	SEC SCREEN- SCREENINGS	SEC SCREEN- EFFLUENT	HYDROCYCLONE S	SCALPING SCREEN
Sediment Source	Arthur Kill	Arthur Kill	Lower Passaic River	Lower Passaic River	Lower Passaic River	Lower Passaic River	Lower Passaic River
Location Identification	TS	WS	PSS	SS1	RS	TS2	TS1
Date Collected	3/3/06	3/3/06	3/16/06	3/16/06	3/16/06	3/16/06	3/16/06
Matrix	Solid	Solid	Solid	Solid	Solid	Solid	Solid
Analyte/Methods (Units)							
Metals/SW6010B (mg/kg)							
Antimony	-	-	-	-	-	-	-
Arsenic	23.4	45.2	11.4	13.3	12	3.0	14.2
Barium	288	303	190	148	196	65.6	176
Beryllium	-	-	-	-	-	-	-
Cadmium	3.7	9.7	7.0	5.7	7.1	1.5	6.3
Chromium III	-	-	-	-	-	-	-
Chromium, Total	118	351	212	164	217	40.3	193
Copper	-	-	-	-	-	-	-
Lead	189	416	420 J	331	412	172	497
Mercury/SW7471A	6.0	13.3	4.6	3.4	3.8	1.2	4.1
Nickel	48	63.2	54.1	44.2	55.8	19.8	53.4
Selenium	1.7	2.9	2.1	2.8	2.2	0.56	2.6
Silver	3.2	9.0	6.9	4.4	6.8	1.6	4.3
Thallium	-	-	-	-	-	-	-
Vanadium	-	-	-	-	-	-	-
Zinc	302 B	642 B	723	734	741	195	836

mg/kg milligrams per kilogram.

Bold Bolded result indicates positively identified compound.

- Not analyzed.

B Analyte detected in an associated blank.

D Sample dilution required for analysis; reported values reflect the dilution.

J Data are estimated due to associated quality control data.

T Analyte was positively identified but the reported concentration is estimated; reported concentration is less than the reporting limit, but greater than the method detection limit.

TABLE 9

METALS SOLID SAMPLE DATA SUMMARY
DEMONSTRATION TESTING AND FULL-SCALE OPERATION OF THE BIOGENESIS SEDIMENT DECONTAMINATION PROCESS
KEASBEY, NEW JERSEY
 (Page 16 of 58)

Field Sample Identification	HYDROCYCLONE OVERFLOW	PSS-210306-0915	SS1-210306-0920	SS2-210306-0925	RS-210306-0930	TS-210306-1030	TS1-210306-1035
Sediment Source	Lower Passaic River	Arhur Kill	Arhur Kill	Arhur Kill	Arhur Kill	Arhur Kill	Arhur Kill
Location Identification	HO	PSS	SS1	SS2	RS	TS	TS1
Date Collected	3/16/06	3/21/06	3/21/06	3/21/06	3/21/06	3/21/06	3/21/06
Matrix	Solid	Solid	Solid	Solid	Solid	Solid	Solid
Analyte/Methods (Units)							
Metals/SW6010B (mg/kg)							
Antimony	-	-	-	-	-	-	-
Arsenic	12.7	20.3	19.5	20.7	25.5	16	6.9
Barium	206	234	92.6	180	372	260	54.3
Beryllium	-	-	-	-	-	-	-
Cadmium	7.7	4.1	2.9	3.0	5.2	2.5	1.3
Chromium III	-	-	-	-	-	-	-
Chromium, Total	232	120 J	86.6	93.5	154	61.5	41.5
Copper	-	-	-	-	-	-	-
Lead	429	201	158	217	272	138	86.1
Mercury/SW7471A	5.0	6.4	2.1	10.9	6.8	2.8	0.64
Nickel	56	34.4	26.6	38.5	44.1	34.3	19.1
Selenium	2.5	2.1 J	1.4	1.2	1.7	1.1	0.42
Silver	7.6	2.9	1.2	1.4	3.5	1.5	0.37
Thallium	-	-	-	-	-	-	-
Vanadium	-	-	-	-	-	-	-
Zinc	779	316 J	393	321	393	212	128

mg/kg milligrams per kilogram.

Bold Bolded result indicates positively identified compound.

- Not analyzed.

B Analyte detected in an associated blank.

D Sample dilution required for analysis; reported values reflect the dilution.

J Data are estimated due to associated quality control data.

T Analyte was positively identified but the reported concentration is estimated; reported concentration is less than the reporting limit, but greater than the method detection limit.

TABLE 9

METALS SOLID SAMPLE DATA SUMMARY
DEMONSTRATION TESTING AND FULL-SCALE OPERATION OF THE BIOGENESIS SEDIMENT DECONTAMINATION PROCESS
KEASBEY, NEW JERSEY
 (Page 17 of 58)

Field Sample Identification	TS2-210306-1040	TS3-210306-1045	TS4-210306-1130	TS5-210306-1135	TS6-210306-1140	TS7-210306-1145	TS-220306-1000
Sediment Source	Arhur Kill	Arhur Kill	Arhur Kill	Arhur Kill	Arhur Kill	Arhur Kill	Arhur Kill
Location Identification	TS2	TS3	TS	TS1	TS2	TS3	TS
Date Collected	3/21/06	3/21/06	3/21/06	3/21/06	3/21/06	3/21/06	3/22/06
Matrix	Solid	Solid	Solid	Solid	Solid	Solid	Solid
Analyte/Methods (Units)							
Metals/SW6010B (mg/kg)							
Antimony	-	-	-	-	-	-	-
Arsenic	11.9	24.5	18.7	10	9.5	23.8	16.8 J
Barium	213	363	282	115	143	370	269 JB
Beryllium	-	-	-	-	-	-	-
Cadmium	1.8	4.0	3.1	1.7	1.6	4.0	2.3
Chromium III	-	-	-	-	-	-	-
Chromium, Total	38.1	98.6	76.8	35.2	38.4	95.5	69.2 J
Copper	-	-	-	-	-	-	-
Lead	127	191	176	515	148	195	175 J
Mercury/SW7471A	1.4	4.8	3.4	0.68	1.2	4.7	2.9
Nickel	29.2	47.8	36.2	27.1	24.9	47.5	34.4 J
Selenium	0.8	2.0	1.3	0.61	0.54	1.8	1.2 J
Silver	0.7	2.6	1.8	0.58	0.54	2.6	1.6
Thallium	-	-	-	-	-	-	-
Vanadium	-	-	-	-	-	-	-
Zinc	173	294	252	341	193	304	213 JB

mg/kg milligrams per kilogram.

Bold Bolded result indicates positively identified compound.

- Not analyzed.

B Analyte detected in an associated blank.

D Sample dilution required for analysis; reported values reflect the dilution.

J Data are estimated due to associated quality control data.

T Analyte was positively identified but the reported concentration is estimated; reported concentration is less than the reporting limit, but greater than the method detection limit.

TABLE 9

METALS SOLID SAMPLE DATA SUMMARY
DEMONSTRATION TESTING AND FULL-SCALE OPERATION OF THE BIOGENESIS SEDIMENT DECONTAMINATION PROCESS
KEASBEY, NEW JERSEY
 (Page 18 of 58)

Field Sample Identification	TS1-220306-1005	TS2-220306-1010	TS3-220306-1015	PSS-230306-1530	SS1-230306-1535	SS2-230306-1540	RS-230306-1545
Sediment Source	Arhur Kill	Arhur Kill	Arhur Kill	Lower Passaic River	Lower Passaic River	Lower Passaic River	Lower Passaic River
Location Identification	TS1	TS2	TS3	PSS	SS1	SS2	RS
Date Collected	3/22/06	3/22/06	3/22/06	3/23/06	3/23/06	3/23/06	3/23/06
Matrix	Solid	Solid	Solid	Solid	Solid	Solid	Solid
Analyte/Methods (Units)							
Metals/SW6010B (mg/kg)							
Antimony	-	-	-	-	-	-	-
Arsenic	12.7	12.4	22.9	10.4	17.7	19.5	14.6
Barium	55 B	231 B	361 B	162	141	188	228
Beryllium	-	-	-	-	-	-	-
Cadmium	1.4	1.4	3.3	6.7	7.4	20.3	9.4
Chromium III	-	-	-	-	-	-	-
Chromium, Total	38.9	37.4	90.3	189	194	275	257
Copper	-	-	-	-	-	-	-
Lead	165	145	196	363	352	811	472
Mercury/SW7471A	1.2	1.4	4.7	4.0	3.9	5.7	5.8
Nickel	21	28.5	44.8	45.2	53.8	65.4	61.8
Selenium	0.63	0.56	1.6	1.3	2.1	4.3	2.0
Silver	0.48	0.97	2.4	6.0	4.2	5.7	8.0
Thallium	-	-	-	-	-	-	-
Vanadium	-	-	-	-	-	-	-
Zinc	165 B	168 B	275 B	647	858	1020	841

mg/kg milligrams per kilogram.

Bold Bolded result indicates positively identified compound.

- Not analyzed.

B Analyte detected in an associated blank.

D Sample dilution required for analysis; reported values reflect the dilution.

J Data are estimated due to associated quality control data.

T Analyte was positively identified but the reported concentration is estimated; reported concentration is less than the reporting limit, but greater than the method detection limit.

TABLE 9

METALS SOLID SAMPLE DATA SUMMARY
DEMONSTRATION TESTING AND FULL-SCALE OPERATION OF THE BIOGENESIS SEDIMENT DECONTAMINATION PROCESS
KEASBEY, NEW JERSEY
 (Page 19 of 58)

Field Sample Identification	TS-230306-0930	TSP-230306-1730	PSS-270306-1100	TS-270306-1320	CENTRATE 1	PSS-300306-1300	SS1-300306-1305
Sediment Source	Lower Passaic River	Arhur Kill	Lower Passaic River	Lower Passaic River	Lower Passaic River	Lower Passaic River	Lower Passaic River
Location Identification	TS	TS	PSS	TS	C1	PSS	SS1
Date Collected	3/23/06	3/23/06	3/27/06	3/27/06	3/30/06	3/30/06	3/30/06
Matrix	Solid	Solid	Solid	Solid	Solid	Solid	Solid
Analyte/Methods (Units)							
Metals/SW6010B (mg/kg)							
Antimony	-	-	-	-	-	-	-
Arsenic	16.6	14.7	13.6	11	27.9	24 J	26.7
Barium	247	254	137	178	332	317	84.9
Beryllium	-	-	-	-	-	-	-
Cadmium	2.1	2.5	5.6	4.5	14.5	5.0 J	1.4
Chromium III	-	-	-	-	-	-	-
Chromium, Total	59 J	66.4	152 J	111	449	163 J	45.5
Copper	-	-	-	-	-	-	-
Lead	159	171	315 J	261	664	249 J	78.4
Mercury/SW7471A	2.6	2.7	5.3	3.6	11.2	6.5	1.9
Nickel	32.3	34.6	41.1	42.4	75.9	44.9 J	28.4
Selenium	1.2 J	0.9	1.2 J	0.67	<6.3	1.6 J	<0.42
Silver	1.4	1.7	4.9 JB	3.2 B	14.2	4.4 J	0.81
Thallium	-	-	-	-	-	-	-
Vanadium	-	-	-	-	-	-	-
Zinc	209 J	253	553	394	1280 B	386 JB	170 B

mg/kg milligrams per kilogram.

Bold Bolded result indicates positively identified compound.

- Not analyzed.

B Analyte detected in an associated blank.

D Sample dilution required for analysis; reported values reflect the dilution.

J Data are estimated due to associated quality control data.

T Analyte was positively identified but the reported concentration is estimated; reported concentration is less than the reporting limit, but greater than the method detection limit.

TABLE 9

METALS SOLID SAMPLE DATA SUMMARY
DEMONSTRATION TESTING AND FULL-SCALE OPERATION OF THE BIOGENESIS SEDIMENT DECONTAMINATION PROCESS
KEASBEY, NEW JERSEY
 (Page 20 of 58)

Field Sample Identification	SS2-300306-1310	RS-300306-1315	TS-300306-1320	TS1-300306-1325	TS2-300306-1330	TS3-300306-1335	WS-300306-1345
Sediment Source	Lower Passaic River	Lower Passaic River	Lower Passaic River	Lower Passaic River	Lower Passaic River	Lower Passaic River	Lower Passaic River
Location Identification	SS2	RS	TS	TS1	TS2	TS3	WS
Date Collected	3/30/06	3/30/06	3/30/06	3/30/06	3/30/06	3/30/06	3/30/06
Matrix	Solid	Solid	Solid	Solid	Solid	Solid	Solid
Analyte/Methods (Units)							
Metals/SW6010B (mg/kg)							
Antimony	-	-	-	-	-	-	-
Arsenic	20.9	28.8	10.7	8.9	5.2	10.6	27.6
Barium	214	389	179	84.8	129	185	340
Beryllium	-	-	-	-	-	-	-
Cadmium	3.1	5.9	3.3	1.3	1.1	3.7	15.2
Chromium III	-	-	-	-	-	-	-
Chromium, Total	81.8	198	89.2	42.7	33.2	94.9	475
Copper	-	-	-	-	-	-	-
Lead	1010	310	226	200	161	224	711
Mercury/SW7471A	2.3	6.9	3.1	1.0	0.79	3.5	11.2
Nickel	27.6	54.2	39	26.2	24	40.7	79.3
Selenium	0.88	2.0	0.67	0.53	<0.36	0.62	2.5
Silver	1.6	5.1	2.5	0.65	0.98	2.9	15.4
Thallium	-	-	-	-	-	-	-
Vanadium	-	-	-	-	-	-	-
Zinc	240 B	469 B	355 B	218 B	188 B	364 B	1360 B

mg/kg milligrams per kilogram.

Bold Bolded result indicates positively identified compound.

- Not analyzed.

B Analyte detected in an associated blank.

D Sample dilution required for analysis; reported values reflect the dilution.

J Data are estimated due to associated quality control data.

T Analyte was positively identified but the reported concentration is estimated; reported concentration is less than the reporting limit, but greater than the method detection limit.

TABLE 9

METALS SOLID SAMPLE DATA SUMMARY
DEMONSTRATION TESTING AND FULL-SCALE OPERATION OF THE BIOGENESIS SEDIMENT DECONTAMINATION PROCESS
KEASBEY, NEW JERSEY
 (Page 21 of 58)

Field Sample Identification	PSS-030406-1500	SS1-030406-1505	SS2-030406-1510	RS-030406-1515	FD-431520	INF-431525	TS-030406-1540
Sediment Source	Arthur Kill	Arthur Kill	Arthur Kill	Arthur Kill	Arthur Kill	Arthur Kill	Arthur Kill
Location Identification	PSS	SS1	SS2	RS	RS Dup	RS Dup	TS
Date Collected	4/3/06	4/3/06	4/3/06	4/3/06	4/3/06	4/3/06	4/3/06
Matrix	Solid	Solid	Solid	Solid	Solid	Solid	Solid
Analyte/Methods (Units)							
Metals/SW6010B (mg/kg)							
Antimony	-	-	-	-	-	-	-
Arsenic	23.8 J	21.4	28.9	22.1	24.3	24.1	15.9
Barium	315	97.1	120	290	285	316	202
Beryllium	-	-	-	-	-	-	-
Cadmium	5.8	2.9	3.6	5.2	5.7	5.8	2.6
Chromium III	-	-	-	-	-	-	-
Chromium, Total	159	61	75.4	147	158	161	63.1
Copper	-	-	-	-	-	-	-
Lead	245	86.8	130	217	230	242	130
Mercury/SW7471A	6.7	1.4	3.3	6.9	6.9	7.3	3.3
Nickel	42.2	27.6	30	39.2	42.7	43.3	30.3
Selenium	1.4 J	<0.45	0.58	1.5	1.5	1.5	0.54
Silver	4.2	1.2	1.5	4.0	4.1	4.7	1.5
Thallium	-	-	-	-	-	-	-
Vanadium	-	-	-	-	-	-	-
Zinc	374 B	291 B	281 B	333 B	355 B	368 B	260 B

mg/kg milligrams per kilogram.

Bold Bolded result indicates positively identified compound.

- Not analyzed.

B Analyte detected in an associated blank.

D Sample dilution required for analysis; reported values reflect the dilution.

J Data are estimated due to associated quality control data.

T Analyte was positively identified but the reported concentration is estimated; reported concentration is less than the reporting limit, but greater than the method detection limit.

TABLE 9

METALS SOLID SAMPLE DATA SUMMARY
DEMONSTRATION TESTING AND FULL-SCALE OPERATION OF THE BIOGENESIS SEDIMENT DECONTAMINATION PROCESS
KEASBEY, NEW JERSEY
 (Page 22 of 58)

Field Sample Identification	TS1-030406-1525	TS2-030406-1530	TS3-030406-1535	WS-030406-1600	PSS-040406-1200	SS1-040406-1205	SS2-040406-1210
Sediment Source	Arthur Kill	Arthur Kill	Arthur Kill	Arthur Kill	Arthur Kill	Arthur Kill	Arthur Kill
Location Identification	TS1	TS2	TS3	WS	PSS	SS1	SS2
Date Collected	4/3/06	4/3/06	4/3/06	4/3/06	4/4/06	4/4/06	4/4/06
Matrix	Solid	Solid	Solid	Solid	Solid	Solid	Solid
Analyte/Methods (Units)							
Metals/SW6010B (mg/kg)							
Antimony	-	-	-	-	-	-	-
Arsenic	11.3	11.2	21.1	46.6	17.6	26.2	22.1
Barium	90.2	64.7	349	381	226	185	109
Beryllium	-	-	-	-	-	-	-
Cadmium	1.6	1.8	4.3	14.3	4.4	2.8	3.5
Chromium III	-	-	-	-	-	-	-
Chromium, Total	47.7	44.6	91	426	120	80.9	74.2
Copper	-	-	-	-	-	-	-
Lead	152	219	171	516	169	139	212
Mercury/SW7471A	1.3	1.3	5.3	16.5	7.1	2.6	3.0
Nickel	20.7	22.9	42	68.9	31.3	24.9	26.5
Selenium	0.43	0.39	1.2	2.9	1.3	0.79	0.65
Silver	0.6	0.69	2.9	10.6	3.1	1.6	1.5
Thallium	-	-	-	-	-	-	-
Vanadium	-	-	-	-	-	-	-
Zinc	184 B	179 B	276 B	831 B	290 B	209 B	308 B

mg/kg milligrams per kilogram.

Bold Bolded result indicates positively identified compound.

- Not analyzed.

B Analyte detected in an associated blank.

D Sample dilution required for analysis; reported values reflect the dilution.

J Data are estimated due to associated quality control data.

T Analyte was positively identified but the reported concentration is estimated; reported concentration is less than the reporting limit, but greater than the method detection limit.

TABLE 9
METALS SOLID SAMPLE DATA SUMMARY
DEMONSTRATION TESTING AND FULL-SCALE OPERATION OF THE BIOGENESIS SEDIMENT DECONTAMINATION PROCESS
KEASBEY, NEW JERSEY
 (Page 23 of 58)

Field Sample Identification	RS-040406-1215	TS-040406-1240	TS1-040406-1225	TS2-040406-1230	TS3-040406-1235	WS-040406-1300	PSS-050406-1200
Sediment Source	Arthur Kill	Arthur Kill	Arthur Kill	Arthur Kill	Arthur Kill	Arthur Kill	Arthur Kill
Location Identification	RS	TS	TS1	TS2	TS3	WS	PSS
Date Collected	4/4/06	4/4/06	4/4/06	4/4/06	4/4/06	4/4/06	4/5/06
Matrix	Solid	Solid	Solid	Solid	Solid	Solid	Solid
Analyte/Methods (Units)							
Metals/SW6010B (mg/kg)							
Antimony	-	-	-	-	-	-	-
Arsenic	21.4	15.6	11.8	10.8	19.4	32.7	28.4
Barium	275	226	89.9	90.9	349	299	339
Beryllium	-	-	-	-	-	-	-
Cadmium	5.3	2.9	2.2	1.4	3.8	10.1	5.9 J
Chromium III	-	-	-	-	-	-	-
Chromium, Total	139	62.9	42.2	49.9	76.4	277	183
Copper	-	-	-	-	-	-	-
Lead	208	133	157	133	155	382	257 J
Mercury/SW7471A	6.6	3.2	1.1	1.5	4.3	11.5	7.4
Nickel	37.1	29.8	20.4	24.4	38.7	53.5	49.2
Selenium	<0.94	0.58	0.46	<0.4	1.2	1.8	2.4
Silver	3.7	1.7	0.61	0.57	2.4	7.8	4.7
Thallium	-	-	-	-	-	-	-
Vanadium	-	-	-	-	-	-	-
Zinc	343 B	212 B	232 B	156 B	255 B	693 B	419 B

mg/kg milligrams per kilogram.
Bold Bolded result indicates positively identified compound.
 - Not analyzed.
 B Analyte detected in an associated blank.
 D Sample dilution required for analysis; reported values reflect the dilution.
 J Data are estimated due to associated quality control data.
 T Analyte was positively identified but the reported concentration is estimated; reported concentration is less than the reporting limit, but greater than the method detection limit.

TABLE 9

METALS SOLID SAMPLE DATA SUMMARY
DEMONSTRATION TESTING AND FULL-SCALE OPERATION OF THE BIOGENESIS SEDIMENT DECONTAMINATION PROCESS
KEASBEY, NEW JERSEY
 (Page 24 of 58)

Field Sample Identification	SS1-050406-1205	SS2-050406-1210	RS-050406-1215	TS-050406-1240	TS1-050406-1225	TS2-050406-1230	TS3-050406-1235
Sediment Source	Arthur Kill	Arthur Kill	Arthur Kill	Arthur Kill	Arthur Kill	Arthur Kill	Arthur Kill
Location Identification	SS1	SS2	RS	TS	TS1	TS2	TS3
Date Collected	4/5/06	4/5/06	4/5/06	4/5/06	4/5/06	4/5/06	4/5/06
Matrix	Solid	Solid	Solid	Solid	Solid	Solid	Solid
Analyte/Methods (Units)							
Metals/SW6010B (mg/kg)							
Antimony	-	-	-	-	-	-	-
Arsenic	23.7	21.2	25.7	17.3	15.8	9.7	19.7
Barium	98.3	131	321	253	83.9	72.6	329
Beryllium	-	-	-	-	-	-	-
Cadmium	2.0	2.4	5.6	2.7	1.4	1.3	3.2
Chromium III	-	-	-	-	-	-	-
Chromium, Total	61.7	82.3	172	69.4	50.4	38.2	79.4
Copper	-	-	-	-	-	-	-
Lead	94.4	201	260	140	244	161	155
Mercury/SW7471A	2.7	3.1	6.8	4.0	1.3	1.3	4.8
Nickel	26.3	23.7	46.7	34.8	26.6	21.5	39.5
Selenium	1.0	1.2	2.2	1.4	0.77	0.5	1.7
Silver	1.3	1.5	4.4	2.0	0.64	0.49	2.5
Thallium	-	-	-	-	-	-	-
Vanadium	-	-	-	-	-	-	-
Zinc	177 B	503 B	405 B	222 B	277 B	137 B	246 B

mg/kg milligrams per kilogram.

Bold Bolded result indicates positively identified compound.

- Not analyzed.

B Analyte detected in an associated blank.

D Sample dilution required for analysis; reported values reflect the dilution.

J Data are estimated due to associated quality control data.

T Analyte was positively identified but the reported concentration is estimated; reported concentration is less than the reporting limit, but greater than the method detection limit.

TABLE 9

METALS SOLID SAMPLE DATA SUMMARY
DEMONSTRATION TESTING AND FULL-SCALE OPERATION OF THE BIOGENESIS SEDIMENT DECONTAMINATION PROCESS
KEASBEY, NEW JERSEY
 (Page 25 of 58)

Field Sample Identification	WS-050406-1300	PSS-060406-1200	SS1-060406-1205	SS2-060406-1210	RS-060406-1215	TS-060406-1240	TS1-060406-1225
Sediment Source	Arthur Kill	Arthur Kill	Arthur Kill	Arthur Kill	Arthur Kill	Arthur Kill	Arthur Kill
Location Identification	WS	PSS	SS1	SS2	RS	TS	TS1
Date Collected	4/5/06	4/6/06	4/6/06	4/6/06	4/6/06	4/6/06	4/6/06
Matrix	Solid	Solid	Solid	Solid	Solid	Solid	Solid
Analyte/Methods (Units)							
Metals/SW6010B (mg/kg)							
Antimony	-	-	-	-	-	-	-
Arsenic	45	29	26.9	28.3	28.9	18.8	12.1
Barium	350	374	134	170	413	309	80
Beryllium	-	-	-	-	-	-	-
Cadmium	11.6	6.0	2.3	2.9	6.2	2.4	1.2
Chromium III	-	-	-	-	-	-	-
Chromium, Total	411	190	86.7	106	196	73.2	47.6
Copper	-	-	-	-	-	-	-
Lead	494	290 J	154	229	298	166	213
Mercury/SW7471A	17.5	8.0	2.4	3.5	7.5	4.0	1.4
Nickel	65.2	51.6	31.7	32.8	53.5	37.2	25.7
Selenium	3.3	2.3 J	1.2	1.4	2.4	1.4	0.65
Silver	10	5.1	1.7	2.1	5.1	2.2	0.55
Thallium	-	-	-	-	-	-	-
Vanadium	-	-	-	-	-	-	-
Zinc	723 B	463 J	223	393	478	231	220

mg/kg milligrams per kilogram.

Bold Bolded result indicates positively identified compound.

- Not analyzed.

B Analyte detected in an associated blank.

D Sample dilution required for analysis; reported values reflect the dilution.

J Data are estimated due to associated quality control data.

T Analyte was positively identified but the reported concentration is estimated; reported concentration is less than the reporting limit, but greater than the method detection limit.

TABLE 9

METALS SOLID SAMPLE DATA SUMMARY
DEMONSTRATION TESTING AND FULL-SCALE OPERATION OF THE BIOGENESIS SEDIMENT DECONTAMINATION PROCESS
KEASBEY, NEW JERSEY
 (Page 26 of 58)

Field Sample Identification	TS2-060406-1230	TS3-060406-1235	WS-060406-1300	PSS-100406-1510	SS1-100406-1515	SS2-100406-1520	RS-100406-1525
Sediment Source	Arthur Kill	Arthur Kill	Arthur Kill	Arthur Kill	Arthur Kill	Arthur Kill	Arthur Kill
Location Identification	TS2	TS3	WS	PSS	SS1	SS2	RS
Date Collected	4/6/06	4/6/06	4/6/06	4/10/06	4/10/06	4/10/06	4/10/06
Matrix	Solid	Solid	Solid	Solid	Solid	Solid	Solid
Analyte/Methods (Units)							
Metals/SW6010B (mg/kg)							
Antimony	-	-	-	-	-	-	-
Arsenic	13.4	19.6	44.5	25.2	27	60.3	25.4
Barium	270	338	357	322	111	121	343
Beryllium	-	-	-	-	-	-	-
Cadmium	1.3	2.8	12.2	5.3	2.1	2.8	5.5
Chromium III	-	-	-	-	-	-	-
Chromium, Total	34.2	82.1	404	174 J	92.7	149	178
Copper	-	-	-	-	-	-	-
Lead	111	158	493	245 J	178	228	252
Mercury/SW7471A	1.5	4.7	16.9	7.9	3.3	3.2	7.6
Nickel	27.1	40.7	67.7	47 J	24.7	33.2	47.6
Selenium	0.5	1.5	3.5	2.3 J	0.99	1.3	3.0
Silver	0.83	2.6	10.2	4.3	1.4	1.7	4.6
Thallium	-	-	-	-	-	-	-
Vanadium	-	-	-	-	-	-	-
Zinc	167	248	766	417 J	227	330	419

mg/kg milligrams per kilogram.

Bold Bolded result indicates positively identified compound.

- Not analyzed.

B Analyte detected in an associated blank.

D Sample dilution required for analysis; reported values reflect the dilution.

J Data are estimated due to associated quality control data.

T Analyte was positively identified but the reported concentration is estimated; reported concentration is less than the reporting limit, but greater than the method detection limit.

TABLE 9

METALS SOLID SAMPLE DATA SUMMARY
DEMONSTRATION TESTING AND FULL-SCALE OPERATION OF THE BIOGENESIS SEDIMENT DECONTAMINATION PROCESS
KEASBEY, NEW JERSEY
 (Page 27 of 58)

Field Sample Identification	TS-100406-1615	TS1-100406-1600	TS2-100406-1605	TS3-100406-1610	WS-100406-1630	PSS-110406-1800	SS1-110406-1805
Sediment Source	Arthur Kill	Arthur Kill	Arthur Kill	Arthur Kill	Arthur Kill	Arthur Kill	Arthur Kill
Location Identification	TS	TS1	TS2	TS3	WS	PSS	SS1
Date Collected	4/10/06	4/10/06	4/10/06	4/10/06	4/10/06	4/11/06	4/11/06
Matrix	Solid	Solid	Solid	Solid	Solid	Solid	Solid
Analyte/Methods (Units)							
Metals/SW6010B (mg/kg)							
Antimony	-	-	-	-	-	-	-
Arsenic	20.3	11.5	10.7	20.2	45.9	26.4	27.9
Barium	339	76.3	153	345	363	310	141
Beryllium	-	-	-	-	-	-	-
Cadmium	2.8	1.2	1.3	2.9	12.8	5.1	2.8
Chromium III	-	-	-	-	-	-	-
Chromium, Total	81.3	48.1	39.8	80.9	429	162	88.1
Copper	-	-	-	-	-	-	-
Lead	173	174	113	163	510	237 J	141
Mercury/SW7471A	4.6	1.7	1.4	4.7	17.2	7.2	3.2
Nickel	42.5	19.9	26.2	42	68.7	44.1	26.6
Selenium	1.8	0.88	0.63	1.7	4.0	1.9 J	1.3
Silver	2.4	0.53	0.64	2.5	10.2	4.3	1.8
Thallium	-	-	-	-	-	-	-
Vanadium	-	-	-	-	-	-	-
Zinc	254	181	189	253	854	379 JB	432 B

mg/kg milligrams per kilogram.

Bold Bolded result indicates positively identified compound.

- Not analyzed.

B Analyte detected in an associated blank.

D Sample dilution required for analysis; reported values reflect the dilution.

J Data are estimated due to associated quality control data.

T Analyte was positively identified but the reported concentration is estimated; reported concentration is less than the reporting limit, but greater than the method detection limit.

TABLE 9

METALS SOLID SAMPLE DATA SUMMARY
DEMONSTRATION TESTING AND FULL-SCALE OPERATION OF THE BIOGENESIS SEDIMENT DECONTAMINATION PROCESS
KEASBEY, NEW JERSEY
 (Page 28 of 58)

Field Sample Identification	SS2-110406-1810	RS-110406-1815	TS-110406-1835	TS1-110406-1820	TS2-110406-1825	TS3-110406-1830	WS-110406-1840
Sediment Source	Arthur Kill	Arthur Kill	Arthur Kill	Arthur Kill	Arthur Kill	Arthur Kill	Arthur Kill
Location Identification	SS2	RS	TS	TS1	TS2	TS3	WS
Date Collected	4/11/06	4/11/06	4/11/06	4/11/06	4/11/06	4/11/06	4/11/06
Matrix	Solid	Solid	Solid	Solid	Solid	Solid	Solid
Analyte/Methods (Units)							
Metals/SW6010B (mg/kg)							
Antimony	-	-	-	-	-	-	-
Arsenic	27.4	25	18.9	18.1	9.9	20	46.2
Barium	164	314	326	89.8	244	341	363
Beryllium	-	-	-	-	-	-	-
Cadmium	2.6	5.4	2.7	1.3	1.0	2.8	13
Chromium III	-	-	-	-	-	-	-
Chromium, Total	98.9	168	73.6	47.4	32.9	79.4	427
Copper	-	-	-	-	-	-	-
Lead	169	254	153	158	110	157	509
Mercury/SW7471A	5.1	7.7	4.3	1.4	1.1	4.7	16.9
Nickel	30	46.3	38.8	19.4	26.2	40.7	68.9
Selenium	1.3	1.8	1.3	0.58	0.52	1.3	3.6
Silver	1.8	4.4	2.3	0.67	0.76	2.6	10.6
Thallium	-	-	-	-	-	-	-
Vanadium	-	-	-	-	-	-	-
Zinc	276 B	433 B	230 B	175 B	144 B	239 B	815 B

mg/kg milligrams per kilogram.

Bold Bolded result indicates positively identified compound.

- Not analyzed.

B Analyte detected in an associated blank.

D Sample dilution required for analysis; reported values reflect the dilution.

J Data are estimated due to associated quality control data.

T Analyte was positively identified but the reported concentration is estimated; reported concentration is less than the reporting limit, but greater than the method detection limit.

TABLE 9

METALS SOLID SAMPLE DATA SUMMARY
DEMONSTRATION TESTING AND FULL-SCALE OPERATION OF THE BIOGENESIS SEDIMENT DECONTAMINATION PROCESS
KEASBEY, NEW JERSEY
 (Page 29 of 58)

Field Sample Identification	PSS-120406-1800	SS1-120406-1805	SS2-120406-1810	RS-120406-1815	TS-120406-1835	TS1-120406-1820	TS2-120406-1825
Sediment Source	Arthur Kill	Arthur Kill	Arthur Kill	Arthur Kill	Arthur Kill	Arthur Kill	Arthur Kill
Location Identification	PSS	SS1	SS2	RS	TS	TS1	TS2
Date Collected	4/12/06	4/12/06	4/12/06	4/12/06	4/12/06	4/12/06	4/12/06
Matrix	Solid	Solid	Solid	Solid	Solid	Solid	Solid
Analyte/Methods (Units)							
Metals/SW6010B (mg/kg)							
Antimony	-	-	-	-	-	-	-
Arsenic	26.9 J	38.8	25.3	26.1	18.3	14.8	10.7
Barium	403 J	140	316	345	324	147	204
Beryllium	-	-	-	-	-	-	-
Cadmium	5.6	2.2	2.4	6.2	2.7	1.5	1.7
Chromium III	-	-	-	-	-	-	-
Chromium, Total	175	153	101	176	75.3	49.4	38.9
Copper	-	-	-	-	-	-	-
Lead	271	140	182	261	156	168	108
Mercury/SW7471A	7.9	2.8	3.2	7.6	4.7	1.5	1.4
Nickel	49.7 J	32.5	33.7	49.3	38.8	22.7	28.5
Selenium	2.5 J	1.2	1.2	2.6	1.3	0.77	0.63
Silver	4.7 J	1.5	1.7	4.6	2.4	0.8	0.74
Thallium	-	-	-	-	-	-	-
Vanadium	-	-	-	-	-	-	-
Zinc	421 JB	246 B	326 B	418 B	237 B	228 B	168 B

mg/kg milligrams per kilogram.

Bold Bolded result indicates positively identified compound.

- Not analyzed.

B Analyte detected in an associated blank.

D Sample dilution required for analysis; reported values reflect the dilution.

J Data are estimated due to associated quality control data.

T Analyte was positively identified but the reported concentration is estimated; reported concentration is less than the reporting limit, but greater than the method detection limit.

TABLE 9

METALS SOLID SAMPLE DATA SUMMARY
DEMONSTRATION TESTING AND FULL-SCALE OPERATION OF THE BIOGENESIS SEDIMENT DECONTAMINATION PROCESS
KEASBEY, NEW JERSEY
 (Page 30 of 58)

Field Sample Identification	TS3-120406-1830	WS-120406-1840	PSS-130406-1700	SS1-130406-1705	SS2-130406-1710	RS-130406-1715	TS-130406-1735
Sediment Source	Arthur Kill	Arthur Kill	Arthur Kill	Arthur Kill	Arthur Kill	Arthur Kill	Arthur Kill
Location Identification	TS3	WS	PSS	SS1	SS2	RS	TS
Date Collected	4/12/06	4/12/06	4/13/06	4/13/06	4/13/06	4/13/06	4/13/06
Matrix	Solid	Solid	Solid	Solid	Solid	Solid	Solid
Analyte/Methods (Units)							
Metals/SW6010B (mg/kg)							
Antimony	-	-	-	-	-	-	-
Arsenic	20.1	43.5	33.6	60.7	37	36.2	20.5
Barium	343	354	371	148	188	399	330
Beryllium	-	-	-	-	-	-	-
Cadmium	3.0	12.3	6.6	3.7	3.7	7.4	2.9
Chromium III	-	-	-	-	-	-	-
Chromium, Total	82.6	405	199	196	140	221	78
Copper	-	-	-	-	-	-	-
Lead	162	481	296	671	284	334	166
Mercury/SW7471A	5.0	16.9	8.8	2.8	6.6	9.2	5.0
Nickel	41.8	66.5	50.5	28.4	49	55.3	39.8
Selenium	1.7	3.1	2.4 J	1.5	1.7	2.7	1.3
Silver	2.6	10.3	5.4	2.2	2.4	5.9	2.5
Thallium	-	-	-	-	-	-	-
Vanadium	-	-	-	-	-	-	-
Zinc	248 B	770 B	461	706	635	520	247

mg/kg milligrams per kilogram.

Bold Bolded result indicates positively identified compound.

- Not analyzed.

B Analyte detected in an associated blank.

D Sample dilution required for analysis; reported values reflect the dilution.

J Data are estimated due to associated quality control data.

T Analyte was positively identified but the reported concentration is estimated; reported concentration is less than the reporting limit, but greater than the method detection limit.

TABLE 9

METALS SOLID SAMPLE DATA SUMMARY
DEMONSTRATION TESTING AND FULL-SCALE OPERATION OF THE BIOGENESIS SEDIMENT DECONTAMINATION PROCESS
KEASBEY, NEW JERSEY
 (Page 31 of 58)

Field Sample Identification	TS1-130406-1720	TS2-130406-1725	TS3-130406-1730	WS-130406-1740	PSS-170406-1700	SS1-170406-1715	SS2-170406-1720
Sediment Source	Arthur Kill	Arthur Kill	Arthur Kill	Arthur Kill	Arthur Kill	Arthur Kill	Arthur Kill
Location Identification	TS1	TS2	TS3	WS	PSS	SS1	SS2
Date Collected	4/13/06	4/13/06	4/13/06	4/13/06	4/17/06	4/17/06	4/17/06
Matrix	Solid	Solid	Solid	Solid	Solid	Solid	Solid
Analyte/Methods (Units)							
Metals/SW6010B (mg/kg)							
Antimony	-	-	-	-	-	-	-
Arsenic	13.1	15	21.6	47.7	30.6	20.6	24.9
Barium	148	218	356	364	344	89	165
Beryllium	-	-	-	-	-	-	-
Cadmium	1.7	1.3	3.1	12.9	5.4	1.7	2.4
Chromium III	-	-	-	-	-	-	-
Chromium, Total	59.3	35.6	83.5	415	167	72.1	107
Copper	-	-	-	-	-	-	-
Lead	286	134	169	515	255	97.2	190
Mercury/SW7471A	1.5	1.2	5.2	17.4	7.2	5.4	2.3
Nickel	24.8	31.7	41.5	69.1	46.1	32.8	29.2
Selenium	0.69	0.52	1.3	3.2	2.2 J	<0.47	0.95
Silver	0.58	1.6	2.7	10.6	4.3	1.1	1.4
Thallium	-	-	-	-	-	-	-
Vanadium	-	-	-	-	-	-	-
Zinc	207	185	259	798	392	164	220

mg/kg milligrams per kilogram.

Bold Bolded result indicates positively identified compound.

- Not analyzed.

B Analyte detected in an associated blank.

D Sample dilution required for analysis; reported values reflect the dilution.

J Data are estimated due to associated quality control data.

T Analyte was positively identified but the reported concentration is estimated; reported concentration is less than the reporting limit, but greater than the method detection limit.

TABLE 9

METALS SOLID SAMPLE DATA SUMMARY
DEMONSTRATION TESTING AND FULL-SCALE OPERATION OF THE BIOGENESIS SEDIMENT DECONTAMINATION PROCESS
KEASBEY, NEW JERSEY
 (Page 32 of 58)

Field Sample Identification	RS-170406-1725	TS-170406-1745	TS1-170406-1730	TS2-170406-1735	TS3-170406-1740	WS-170406-1745	PSS-180406-1700
Sediment Source	Arthur Kill	Arthur Kill	Arthur Kill	Arthur Kill	Arthur Kill	Arthur Kill	Arthur Kill
Location Identification	RS	TS	TS1	TS2	TS3	WS	PSS
Date Collected	4/17/06	4/17/06	4/17/06	4/17/06	4/17/06	4/17/06	4/18/06
Matrix	Solid	Solid	Solid	Solid	Solid	Solid	Solid
Analyte/Methods (Units)							
Metals/SW6010B (mg/kg)							
Antimony	-	-	-	-	-	-	-
Arsenic	29.6	19	12.5	11.1	22.6	52.5	28.9
Barium	353	289	89.9	228	338	350	307
Beryllium	-	-	-	-	-	-	-
Cadmium	5.6	2.2	1.6	1.1	2.9	12.6	5.7 J
Chromium III	-	-	-	-	-	-	-
Chromium, Total	167	59.8	37.7	26	74.9	394	141
Copper	-	-	-	-	-	-	-
Lead	260	139	154	110	151	494	295 J
Mercury/SW7471A	6.4	3.3	1.2	0.95	4.1	17.5	6.3
Nickel	45.9	33	19.7	23.7	38.6	64	40.1 J
Selenium	1.9	0.85	0.6	<0.34	1.2	3.2	1.8 J
Silver	4.4	1.7	0.49	0.68	2.4	9.8	3.6
Thallium	-	-	-	-	-	-	-
Vanadium	-	-	-	-	-	-	-
Zinc	432	199	175	142	234	769	351 JB

mg/kg milligrams per kilogram.

Bold Bolded result indicates positively identified compound.

- Not analyzed.

B Analyte detected in an associated blank.

D Sample dilution required for analysis; reported values reflect the dilution.

J Data are estimated due to associated quality control data.

T Analyte was positively identified but the reported concentration is estimated; reported concentration is less than the reporting limit, but greater than the method detection limit.

TABLE 9

METALS SOLID SAMPLE DATA SUMMARY
DEMONSTRATION TESTING AND FULL-SCALE OPERATION OF THE BIOGENESIS SEDIMENT DECONTAMINATION PROCESS
KEASBEY, NEW JERSEY
 (Page 33 of 58)

Field Sample Identification	SS1-180406-1705	SS2-180406-1710	RS-180406-1715	TS-180406-1735	TS1-180406-1720	TS2-180406-1725	TS3-180406-1730
Sediment Source	Arthur Kill	Arthur Kill	Arthur Kill	Arthur Kill	Arthur Kill	Arthur Kill	Arthur Kill
Location Identification	SS1	SS2	RS	TS	TS1	TS2	TS3
Date Collected	4/18/06	4/18/06	4/18/06	4/18/06	4/18/06	4/18/06	4/18/06
Matrix	Solid	Solid	Solid	Solid	Solid	Solid	Solid
Analyte/Methods (Units)							
Metals/SW6010B (mg/kg)							
Antimony	-	-	-	-	-	-	-
Arsenic	33.6	29	36.8	19	14	14.2	22.4
Barium	140	155	403	295	92.2	321	332
Beryllium	-	-	-	-	-	-	-
Cadmium	2.4	2.8	6.2	2.3	1.4	1.3	3.1
Chromium III	-	-	-	-	-	-	-
Chromium, Total	76.6	79.7	186	59.3	40	32.1	78.4
Copper	-	-	-	-	-	-	-
Lead	916	157	281	162	160	134	156
Mercury/SW7471A	2.9	3.1	7.1	3.2	1.3	1.1	5.0
Nickel	26.8	30.6	54.3	33.2	20.8	26.5	38.9
Selenium	1.4	1.3	2.2	1.0	0.91	0.62	1.5
Silver	1.6	1.6	4.8	1.7	0.61	1.2	2.4
Thallium	-	-	-	-	-	-	-
Vanadium	-	-	-	-	-	-	-
Zinc	300 B	350 B	474 B	213 B	207 B	168 B	247 B

mg/kg milligrams per kilogram.

Bold Bolded result indicates positively identified compound.

- Not analyzed.

B Analyte detected in an associated blank.

D Sample dilution required for analysis; reported values reflect the dilution.

J Data are estimated due to associated quality control data.

T Analyte was positively identified but the reported concentration is estimated; reported concentration is less than the reporting limit, but greater than the method detection limit.

TABLE 9
METALS SOLID SAMPLE DATA SUMMARY
DEMONSTRATION TESTING AND FULL-SCALE OPERATION OF THE BIOGENESIS SEDIMENT DECONTAMINATION PROCESS
KEASBEY, NEW JERSEY
(Page 34 of 58)

Field Sample Identification	WS-180406-1740	PSS-190406-0900	SS1-190406-0905	SS2-190406-0910	RS-190406-0915	TS-190406-0845	TS1-190406-0845
Sediment Source	Arthur Kill	Arthur Kill	Arthur Kill	Arthur Kill	Arthur Kill	Arthur Kill	Arthur Kill
Location Identification	WS	PSS	SS1	SS2	RS	TS	TS1
Date Collected	4/18/06	4/19/06	4/19/06	4/19/06	4/19/06	4/19/06	4/19/06
Matrix	Solid	Solid	Solid	Solid	Solid	Solid	Solid
Analyte/Methods (Units)							
Metals/SW6010B (mg/kg)							
Antimony	-	-	-	-	-	-	-
Arsenic	51.3	35.8	57.4	32.8	40.6	17.2	34.2
Barium	350	400	134	226	472	270	104
Beryllium	-	-	-	-	-	-	-
Cadmium	12.7	6.0	3.1	3.4	6.3	1.9	1.1
Chromium III	-	-	-	-	-	-	-
Chromium, Total	404	185	102	86.4	196	51.4	35
Copper	-	-	-	-	-	-	-
Lead	491	294 J	178	506	343	126	114
Mercury/SW7471A	17.6	7.2	3.4	3.5	8.1	2.6	1.1
Nickel	65.3	53.8	33.6	28.2	58.3	30.7	18.7
Selenium	3.9	2.9 J	1.9	1.3	2.6	0.88	0.52
Silver	10	4.7	1.9	1.6	5.0	1.5	0.56
Thallium	-	-	-	-	-	-	-
Vanadium	-	-	-	-	-	-	-
Zinc	784 B	475 J	307	1080	518	205	195

mg/kg milligrams per kilogram.
Bold Bolded result indicates positively identified compound.
- Not analyzed.
B Analyte detected in an associated blank.
D Sample dilution required for analysis; reported values reflect the dilution.
J Data are estimated due to associated quality control data.
T Analyte was positively identified but the reported concentration is estimated; reported concentration is less than the reporting limit, but greater than the method detection limit.

TABLE 9

METALS SOLID SAMPLE DATA SUMMARY
DEMONSTRATION TESTING AND FULL-SCALE OPERATION OF THE BIOGENESIS SEDIMENT DECONTAMINATION PROCESS
KEASBEY, NEW JERSEY
 (Page 35 of 58)

Field Sample Identification	TS2-190406-0845	TS3-190406-0845	WS-190406-1600	PSS-200406-1600	SS1-200406-1605	SS2-200406-1610	RS-200406-1615
Sediment Source	Arthur Kill	Arthur Kill	Arthur Kill	Arthur Kill	Arthur Kill	Arthur Kill	Arthur Kill
Location Identification	TS2	TS3	WS	PSS	SS1	SS2	RS
Date Collected	4/19/06	4/19/06	4/19/06	4/20/06	4/20/06	4/20/06	4/20/06
Matrix	Solid	Solid	Solid	Solid	Solid	Solid	Solid
Analyte/Methods (Units)							
Metals/SW6010B (mg/kg)							
Antimony	-	-	-	-	-	-	-
Arsenic	12.1	24.3	52.7	29.1	28.8	27.6	40.1
Barium	240	328	339	304	117	275	441
Beryllium	-	-	-	-	-	-	-
Cadmium	0.94	2.9	11.5	4.8	2.4	2.4	6.5
Chromium III	-	-	-	-	-	-	-
Chromium, Total	25.4	79.3	381	154	68.3	65.1	203
Copper	-	-	-	-	-	-	-
Lead	104	153	483	264 J	114	170	314
Mercury/SW7471A	1.2	4.8	16.5	6.9	2.8	2.5	8.5 B
Nickel	23.5	38.9	64.6	42.2	26.2	24.6	59
Selenium	0.38	1.6	3.8	2.1 J	1.0	1.2	2.3
Silver	0.54	2.4	9.0	3.9	1.5	1.4	5.1
Thallium	-	-	-	-	-	-	-
Vanadium	-	-	-	-	-	-	-
Zinc	144	252	747	372 B	269 B	300 B	505 B

mg/kg milligrams per kilogram.

Bold Bolded result indicates positively identified compound.

- Not analyzed.

B Analyte detected in an associated blank.

D Sample dilution required for analysis; reported values reflect the dilution.

J Data are estimated due to associated quality control data.

T Analyte was positively identified but the reported concentration is estimated; reported concentration is less than the reporting limit, but greater than the method detection limit.

TABLE 9

METALS SOLID SAMPLE DATA SUMMARY
DEMONSTRATION TESTING AND FULL-SCALE OPERATION OF THE BIOGENESIS SEDIMENT DECONTAMINATION PROCESS
KEASBEY, NEW JERSEY
 (Page 36 of 58)

Field Sample Identification	TS-200406-1635	TS1-200406-1620	TS2-200406-1625	TS3-200406-1630	WS-200406-1640	PSS-210406-1400	SS1-210406-1405
Sediment Source	Arthur Kill	Arthur Kill	Arthur Kill	Arthur Kill	Arthur Kill	Arthur Kill	Arthur Kill
Location Identification	TS	TS1	TS2	TS3	WS	PSS	SS1
Date Collected	4/20/06	4/20/06	4/20/06	4/20/06	4/20/06	4/21/06	4/21/06
Matrix	Solid	Solid	Solid	Solid	Solid	Solid	Solid
Analyte/Methods (Units)							
Metals/SW6010B (mg/kg)							
Antimony	-	-	-	-	-	-	-
Arsenic	18.8	13.1	11.8	24.1	52.3	30.5 J	24
Barium	293	84.1	248	330	339	331	146
Beryllium	-	-	-	-	-	-	-
Cadmium	2.1	1.3	1.4	2.8	11.9	5.6	2.3
Chromium III	-	-	-	-	-	-	-
Chromium, Total	58.3	40.8	27.5	79.8	388	165	54
Copper	-	-	-	-	-	-	-
Lead	136	121	124	162	486	260 J	79.5
Mercury/SW7471A	3.4	1.1 B	1.1	4.7	32.3	6.5	2.4
Nickel	33.1	19.2	26.4	39.7	64.1	46.4 J	75.1
Selenium	0.8	<0.4	<0.36	1.4	3.4	2.4 J	<0.96
Silver	1.6	0.47	0.6	2.4	9.4	4.2	1.1
Thallium	-	-	-	-	-	-	-
Vanadium	-	-	-	-	-	-	-
Zinc	251 B	199 B	162 B	250 B	757 B	393 J	313

mg/kg milligrams per kilogram.

Bold Bolded result indicates positively identified compound.

- Not analyzed.

B Analyte detected in an associated blank.

D Sample dilution required for analysis; reported values reflect the dilution.

J Data are estimated due to associated quality control data.

T Analyte was positively identified but the reported concentration is estimated; reported concentration is less than the reporting limit, but greater than the method detection limit.

TABLE 9
METALS SOLID SAMPLE DATA SUMMARY
DEMONSTRATION TESTING AND FULL-SCALE OPERATION OF THE BIOGENESIS SEDIMENT DECONTAMINATION PROCESS
KEASBEY, NEW JERSEY
 (Page 37 of 58)

Field Sample Identification	SS2-210406-1410	RS-210406-1415	TS-210406-1435	TS1-210406-1420	TS2-210406-1425	TS3-210406-1430	WS-210406-1440
Sediment Source	Arthur Kill	Arthur Kill	Arthur Kill	Arthur Kill	Arthur Kill	Arthur Kill	Arthur Kill
Location Identification	SS2	RS	TS	TS1	TS2	TS3	WS
Date Collected	4/21/06	4/21/06	4/21/06	4/21/06	4/21/06	4/21/06	4/21/06
Matrix	Solid	Solid	Solid	Solid	Solid	Solid	Solid
Analyte/Methods (Units)							
Metals/SW6010B (mg/kg)							
Antimony	-	-	-	-	-	-	-
Arsenic	22.8	31	19.8	12.5	9.6	21.9	47.5
Barium	175	356	285	106	171	322	329
Beryllium	-	-	-	-	-	-	-
Cadmium	2.5	5.8	2.5	1.1	0.91	3.0	11.5
Chromium III	-	-	-	-	-	-	-
Chromium, Total	109	177	64.9	37.5	19.4	75	360
Copper	-	-	-	-	-	-	-
Lead	162	273	143	111	110	150	453
Mercury/SW7471A	2.4	6.3	3.5	1.0	1.2	4.3	14.8
Nickel	65.2	50.4	34.5	19.6	20.6	36.7	60.2
Selenium	0.99	2.3	1.2	<0.73	0.47 T	1.6	3.5
Silver	1.6	4.6	1.9	0.41 T	0.41 T	2.3	8.9
Thallium	-	-	-	-	-	-	-
Vanadium	-	-	-	-	-	-	-
Zinc	292	416	212	234	121	226	704

mg/kg milligrams per kilogram.
Bold Bolded result indicates positively identified compound.
 - Not analyzed.
 B Analyte detected in an associated blank.
 D Sample dilution required for analysis; reported values reflect the dilution.
 J Data are estimated due to associated quality control data.
 T Analyte was positively identified but the reported concentration is estimated; reported concentration is less than the reporting limit, but greater than the method detection limit.

TABLE 9

METALS SOLID SAMPLE DATA SUMMARY
DEMONSTRATION TESTING AND FULL-SCALE OPERATION OF THE BIOGENESIS SEDIMENT DECONTAMINATION PROCESS
KEASBEY, NEW JERSEY
 (Page 38 of 58)

Field Sample Identification	PSS-240406-1600	SS1-240406-1605	SS2-240406-1610	RS-240406-1615	INF1-250406-1845	INF1-260406-1345	TS-240406-1635
Sediment Source	Arthur Kill	Arthur Kill	Arthur Kill	Arthur Kill	Arthur Kill	Arthur Kill	Arthur Kill
Location Identification	PSS	SS1	SS2	RS	RS Dup	RS Dup	TS
Date Collected	4/24/06	4/24/06	4/24/06	4/24/06	4/24/06	4/24/06	4/24/06
Matrix	Solid	Solid	Solid	Solid	Solid	Solid	Solid
Analyte/Methods (Units)							
Metals/SW6010B (mg/kg)							
Antimony	-	-	-	-	-	-	-
Arsenic	36.7	31.6	78.2	27.4	33.9	34.9	21.5
Barium	424	111	158	320	428	425	323
Beryllium	-	-	-	-	-	-	-
Cadmium	7.1 J	2.3	2.2	4.9	6.0	6.1	2.7
Chromium III	-	-	-	-	-	-	-
Chromium, Total	206	129	244	154	191	210	76.1
Copper	-	-	-	-	-	-	-
Lead	314 J	162	348	236	281	303	154
Mercury/SW7471A	6.8	2.6	3.0	4.7	7.9	7.8	4.1
Nickel	57	28.4	34.3	43.3	55.3	64.7	38.9
Selenium	2.7 J	1.4	1.1	2.3	2.2	2.4	1.1
Silver	5.2	2.2	1.4	3.9	5.0	4.9	2.3
Thallium	-	-	-	-	-	-	-
Vanadium	-	-	-	-	-	-	-
Zinc	497 J	223	229	370	462 B	485	236

mg/kg milligrams per kilogram.

Bold Bolded result indicates positively identified compound.

- Not analyzed.

B Analyte detected in an associated blank.

D Sample dilution required for analysis; reported values reflect the dilution.

J Data are estimated due to associated quality control data.

T Analyte was positively identified but the reported concentration is estimated; reported concentration is less than the reporting limit, but greater than the method detection limit.

TABLE 9

METALS SOLID SAMPLE DATA SUMMARY
DEMONSTRATION TESTING AND FULL-SCALE OPERATION OF THE BIOGENESIS SEDIMENT DECONTAMINATION PROCESS
KEASBEY, NEW JERSEY
 (Page 39 of 58)

Field Sample Identification	TS1-240406-1620	TS2-240406-1625	TS3-240406-1630	WS-240406-1640	PSS-250406-1800	SS2-250406-1810	RS-250406-1815
Sediment Source	Arthur Kill	Arthur Kill	Arthur Kill	Arthur Kill	Arthur Kill	Arthur Kill	Arthur Kill
Location Identification	TS1	TS2	TS3	WS	PSS	SS2	RS
Date Collected	4/24/06	4/24/06	4/24/06	4/24/06	4/25/06	4/25/06	4/25/06
Matrix	Solid	Solid	Solid	Solid	Solid	Solid	Solid
Analyte/Methods (Units)							
Metals/SW6010B (mg/kg)							
Antimony	-	-	-	-	-	-	-
Arsenic	11.6	11.3	23.3	50.4	27.9	24.5	28.7
Barium	98.2	306	329	352	368 J	206	324
Beryllium	-	-	-	-	-	-	-
Cadmium	1.1	0.98	2.8	11.9	5.0	2.4	5.1
Chromium III	-	-	-	-	-	-	-
Chromium, Total	42.3	24.7	81	393	158	74.9	165
Copper	-	-	-	-	-	-	-
Lead	185	96.8	159	487	275 J	611	247
Mercury/SW7471A	1.2	1.5	4.4	15.7	6.8	2.6	7.2
Nickel	19.7	29.9	40.2	64.8	45.2 J	34.5	45.3
Selenium	0.64	<0.37	1.2	3.6	1.9 J	1.0	1.8
Silver	0.5	0.85	2.5	9.6	4.1	1.6	4.2
Thallium	-	-	-	-	-	-	-
Vanadium	-	-	-	-	-	-	-
Zinc	185	153	245	766	395 JB	286 B	388 B

mg/kg milligrams per kilogram.

Bold Bolded result indicates positively identified compound.

- Not analyzed.

B Analyte detected in an associated blank.

D Sample dilution required for analysis; reported values reflect the dilution.

J Data are estimated due to associated quality control data.

T Analyte was positively identified but the reported concentration is estimated; reported concentration is less than the reporting limit, but greater than the method detection limit.

TABLE 9

METALS SOLID SAMPLE DATA SUMMARY
DEMONSTRATION TESTING AND FULL-SCALE OPERATION OF THE BIOGENESIS SEDIMENT DECONTAMINATION PROCESS
KEASBEY, NEW JERSEY
 (Page 40 of 58)

Field Sample Identification	TS-250406-1835	TS1-250406-1820	TS2-250406-1825	TS3-250406-1830	WS-250406-1840	PSS-260406-1300	SS1-260406-1305
Sediment Source	Arthur Kill	Arthur Kill	Arthur Kill	Arthur Kill	Arthur Kill	Arthur Kill	Arthur Kill
Location Identification	TS	TS1	TS2	TS3	WS	PSS	SS1
Date Collected	4/25/06	4/25/06	4/25/06	4/25/06	4/25/06	4/26/06	4/26/06
Matrix	Solid	Solid	Solid	Solid	Solid	Solid	Solid
Analyte/Methods (Units)							
Metals/SW6010B (mg/kg)							
Antimony	-	-	-	-	-	-	-
Arsenic	20.8	13.1	10.9	21.7	48.3	27	24.6
Barium	318	114	277	331	349	333	267
Beryllium	-	-	-	-	-	-	-
Cadmium	2.5	1.1	1.2	2.7	11.3	4.7	2.7
Chromium III	-	-	-	-	-	-	-
Chromium, Total	73.3	52.9	27.6	78.8	370	151	56.8
Copper	-	-	-	-	-	-	-
Lead	154	126	95.1	154	462	220 J	80.1
Mercury/SW7471A	3.6	1.2	0.95	5.1	16.2	6.9	1.6
Nickel	38.2	52.9	24.8	39.4	64.2	42.7 J	37.5
Selenium	1.2	0.58	0.36	1.4	3.0	1.7 J	<1.9
Silver	2.2	0.6	0.68	2.4	9.2	3.8	2.1
Thallium	-	-	-	-	-	-	-
Vanadium	-	-	-	-	-	-	-
Zinc	228 B	168 B	143 B	237 B	729 B	371 J	442

mg/kg milligrams per kilogram.

Bold Bolded result indicates positively identified compound.

- Not analyzed.

B Analyte detected in an associated blank.

D Sample dilution required for analysis; reported values reflect the dilution.

J Data are estimated due to associated quality control data.

T Analyte was positively identified but the reported concentration is estimated; reported concentration is less than the reporting limit, but greater than the method detection limit.

TABLE 9

METALS SOLID SAMPLE DATA SUMMARY
DEMONSTRATION TESTING AND FULL-SCALE OPERATION OF THE BIOGENESIS SEDIMENT DECONTAMINATION PROCESS
KEASBEY, NEW JERSEY
 (Page 41 of 58)

Field Sample Identification	SS2-260406-1310	RS-260406-1315	TS-260406-1335	TS1-260406-1320	TS2-260406-1325	TS3-260406-1330	WS-260406-1340
Sediment Source	Arthur Kill	Arthur Kill	Arthur Kill	Arthur Kill	Arthur Kill	Arthur Kill	Arthur Kill
Location Identification	SS2	RS	TS	TS1	TS2	TS3	WS
Date Collected	4/26/06	4/26/06	4/26/06	4/26/06	4/26/06	4/26/06	4/26/06
Matrix	Solid	Solid	Solid	Solid	Solid	Solid	Solid
Analyte/Methods (Units)							
Metals/SW6010B (mg/kg)							
Antimony	-	-	-	-	-	-	-
Arsenic	17.9	27.2	19.5	8.5	11.5	21.9	51.1
Barium	167	301	306	59.2	238	333	357
Beryllium	-	-	-	-	-	-	-
Cadmium	2.2	4.8	2.3	0.9	1.2	2.6	12
Chromium III	-	-	-	-	-	-	-
Chromium, Total	77.9	158	67.7	38.8	36.6	75.5	395
Copper	-	-	-	-	-	-	-
Lead	154	231	156	93.2	111	156	491
Mercury/SW7471A	2.4	7.0	3.9	1.3	1.2	4.6	17.1
Nickel	26.7	44.6	35.8	25.9	28.2	39.4	66.8
Selenium	0.84	1.7	0.9	0.48	<0.37	1.4	3.1
Silver	1.3	4.0	2.0	0.53	1.5	2.3	9.7
Thallium	-	-	-	-	-	-	-
Vanadium	-	-	-	-	-	-	-
Zinc	215	368	215	146	159	234	773

mg/kg milligrams per kilogram.

Bold Bolded result indicates positively identified compound.

- Not analyzed.

B Analyte detected in an associated blank.

D Sample dilution required for analysis; reported values reflect the dilution.

J Data are estimated due to associated quality control data.

T Analyte was positively identified but the reported concentration is estimated; reported concentration is less than the reporting limit, but greater than the method detection limit.

TABLE 9

METALS SOLID SAMPLE DATA SUMMARY
DEMONSTRATION TESTING AND FULL-SCALE OPERATION OF THE BIOGENESIS SEDIMENT DECONTAMINATION PROCESS
KEASBEY, NEW JERSEY
 (Page 42 of 58)

Field Sample Identification	PSS-270406-1700	SS1-270406-1705	SS2-270406-1710	RS-270406-1715	TS-270406-1735	TS1-270406-1720	TS2-270406-1725
Sediment Source	Arthur Kill	Arthur Kill	Arthur Kill	Arthur Kill	Arthur Kill	Arthur Kill	Arthur Kill
Location Identification	PSS	SS1	SS2	RS	TS	TS1	TS2
Date Collected	4/27/06	4/27/06	4/27/06	4/27/06	4/27/06	4/27/06	4/27/06
Matrix	Solid	Solid	Solid	Solid	Solid	Solid	Solid
Analyte/Methods (Units)							
Metals/SW6010B (mg/kg)							
Antimony	-	-	-	-	-	-	-
Arsenic	34.2	41.4	28.4	28.4	22.2	11.8	11.9
Barium	385 J	155	147	323	346	117	322
Beryllium	-	-	-	-	-	-	-
Cadmium	6.6	2.9	3.0	5.4	2.9	1.3	1.4
Chromium III	-	-	-	-	-	-	-
Chromium, Total	199	106	96.3	164	82	57.7	32.7
Copper	-	-	-	-	-	-	-
Lead	287 J	146	252	249	161	154	107
Mercury/SW7471A	7.7	3.6	3.4	6.7	5.1	1.1	1.1
Nickel	49.8	29.1	34.3	41.6	38.5	21.9	27.1
Selenium	2.4 J	1.3	0.92	1.6	0.95	<0.38	<0.33
Silver	5.3	1.6	1.7	4.1	2.4	2.7	0.82
Thallium	-	-	-	-	-	-	-
Vanadium	-	-	-	-	-	-	-
Zinc	476 J	754	299	388	242	190	145

mg/kg milligrams per kilogram.

Bold Bolded result indicates positively identified compound.

- Not analyzed.

B Analyte detected in an associated blank.

D Sample dilution required for analysis; reported values reflect the dilution.

J Data are estimated due to associated quality control data.

T Analyte was positively identified but the reported concentration is estimated; reported concentration is less than the reporting limit, but greater than the method detection limit.

TABLE 9

METALS SOLID SAMPLE DATA SUMMARY
DEMONSTRATION TESTING AND FULL-SCALE OPERATION OF THE BIOGENESIS SEDIMENT DECONTAMINATION PROCESS
KEASBEY, NEW JERSEY
 (Page 43 of 58)

Field Sample Identification	TS3-270406-1730	WS-270406-1740	PSS-280406-1100	SS1-280406-1105	SS2-280406-1110	RS-280406-1115	TS-280406-1135
Sediment Source	Arthur Kill	Arthur Kill	Arthur Kill	Arthur Kill	Arthur Kill	Arthur Kill	Arthur Kill
Location Identification	TS3	WS	PSS	SS1	SS2	RS	TS
Date Collected	4/27/06	4/27/06	4/28/06	4/28/06	4/28/06	4/28/06	4/28/06
Matrix	Solid	Solid	Solid	Solid	Solid	Solid	Solid
Analyte/Methods (Units)							
Metals/SW6010B (mg/kg)							
Antimony	-	-	-	-	-	-	-
Arsenic	23.9	55.4	33.8	19.2	18.9	30.2	20.9
Barium	364	384	381	94.1	112	271	317
Beryllium	-	-	-	-	-	-	-
Cadmium	3.2	13.7	6.5	1.8	1.9	4.5	2.8
Chromium III	-	-	-	-	-	-	-
Chromium, Total	88.7	442	202	90.1	61	141	74.1
Copper	-	-	-	-	-	-	-
Lead	171	527	317 J	137	120	232	154
Mercury/SW7471A	5.3	19	8.7	2.3	2.0	7.2	4.9
Nickel	41.6	61.7	51.6	25.2	22.7	36.9	36.3
Selenium	1.2	2.7	2.3 J	0.67	0.6	1.1	1.1
Silver	2.7	10.5	4.8	1.0	1.1	3.6	2.3
Thallium	-	-	-	-	-	-	-
Vanadium	-	-	-	-	-	-	-
Zinc	261	809	473 J	247	234	328	232

mg/kg milligrams per kilogram.

Bold Bolded result indicates positively identified compound.

- Not analyzed.

B Analyte detected in an associated blank.

D Sample dilution required for analysis; reported values reflect the dilution.

J Data are estimated due to associated quality control data.

T Analyte was positively identified but the reported concentration is estimated; reported concentration is less than the reporting limit, but greater than the method detection limit.

TABLE 9

METALS SOLID SAMPLE DATA SUMMARY
DEMONSTRATION TESTING AND FULL-SCALE OPERATION OF THE BIOGENESIS SEDIMENT DECONTAMINATION PROCESS
KEASBEY, NEW JERSEY
 (Page 44 of 58)

Field Sample Identification	TSGRAB-280406-1115	TS1-280406-1120	TS1GRAB-280406-0800	TS1GRAB-280406-1100	TS2-280406-1125	TS2GRAB-280406-0805	TS2GRAB-280406-1105
Sediment Source	Arthur Kill	Arthur Kill	Arthur Kill	Arthur Kill	Arthur Kill	Arthur Kill	Arthur Kill
Location Identification	TS	TS1	TS1	TS1	TS2	TS2	TS2
Date Collected	4/28/06	4/28/06	4/28/06	4/28/06	4/28/06	4/28/06	4/28/06
Matrix	Solid	Solid	Solid	Solid	Solid	Solid	Solid
Analyte/Methods (Units)							
Metals/SW6010B (mg/kg)							
Antimony	-	-	-	-	-	-	-
Arsenic	18.7	9.4	23.5	17.4	12.1	11	11.8
Barium	281	55.9	144	67.3	266	255	299
Beryllium	-	-	-	-	-	-	-
Cadmium	2.5	1.0	1.3	0.9	1.1	1.1	2.5
Chromium III	-	-	-	-	-	-	-
Chromium, Total	67.1	35.8	53.6	52.1	30.3	28.9	29.6
Copper	-	-	-	-	-	-	-
Lead	145	86.8	145	104	114	112	122
Mercury/SW7471A	4.2	0.98	1.0	0.9	1.2	1.2	1.2
Nickel	34	17.5	23.7	16.5	26	24.1	25.5
Selenium	0.9	<0.37	<0.36	<0.37	<0.34	<0.34	<0.34
Silver	2.0	0.45	0.47	0.34 T	0.69	0.7	0.79
Thallium	-	-	-	-	-	-	-
Vanadium	-	-	-	-	-	-	-
Zinc	211	154	316	139	148	147	159

mg/kg milligrams per kilogram.

Bold Bolded result indicates positively identified compound.

- Not analyzed.

B Analyte detected in an associated blank.

D Sample dilution required for analysis; reported values reflect the dilution.

J Data are estimated due to associated quality control data.

T Analyte was positively identified but the reported concentration is estimated; reported concentration is less than the reporting limit, but greater than the method detection limit.

TABLE 9

METALS SOLID SAMPLE DATA SUMMARY
DEMONSTRATION TESTING AND FULL-SCALE OPERATION OF THE BIOGENESIS SEDIMENT DECONTAMINATION PROCESS
KEASBEY, NEW JERSEY
 (Page 45 of 58)

Field Sample Identification	TS3-280406-1130	TS3GRAB-280406-0810	TS3GRAB-280406-1110	TSGRAB-280406-0815	WS-280406-1140	PSS-010506-1600	SS1-010506-1605
Sediment Source	Arthur Kill	Arthur Kill	Arthur Kill	Arthur Kill	Arthur Kill	Lower Passaic River	Lower Passaic River
Location Identification	TS3	TS3	TS3	TS	WS	PSS	SS1
Date Collected	4/28/06	4/28/06	4/28/06	4/28/06	4/28/06	5/1/06	5/1/06
Matrix	Solid	Solid	Solid	Solid	Solid	Solid	Solid
Analyte/Methods (Units)							
Metals/SW6010B (mg/kg)							
Antimony	-	-	-	-	-	-	-
Arsenic	22.1	22.5	22.4	18.1	55.7	15.4 J	13.9
Barium	331	338	330	279	369	256	119
Beryllium	-	-	-	-	-	-	-
Cadmium	3.0	3.1	3.1	2.3	14	7.7 J	4.8
Chromium III	-	-	-	-	-	-	-
Chromium, Total	78.4	81.4	79.5	63.2	455	256 J	153
Copper	-	-	-	-	-	-	-
Lead	157	160	164	137	510	521 J	346
Mercury/SW7471A	5.2	5.4	5.3	3.7	19.3	6.0	2.8
Nickel	37	37	38.1	30.5	57.8	70 J	44.4
Selenium	1.0	1.2	1.1	0.98	3.1	3.9 J	3.3
Silver	2.4	2.5	2.4	1.8	10.4	9.3 J	4.0
Thallium	-	-	-	-	-	-	-
Vanadium	-	-	-	-	-	-	-
Zinc	228	227	240	193	788	935 JB	683 B

mg/kg milligrams per kilogram.

Bold Bolded result indicates positively identified compound.

- Not analyzed.

B Analyte detected in an associated blank.

D Sample dilution required for analysis; reported values reflect the dilution.

J Data are estimated due to associated quality control data.

T Analyte was positively identified but the reported concentration is estimated; reported concentration is less than the reporting limit, but greater than the method detection limit.

TABLE 9

METALS SOLID SAMPLE DATA SUMMARY
DEMONSTRATION TESTING AND FULL-SCALE OPERATION OF THE BIOGENESIS SEDIMENT DECONTAMINATION PROCESS
KEASBEY, NEW JERSEY
 (Page 46 of 58)

Field Sample Identification	SS2-010506-1610	RS-010506-1615	TS-010506-1635	TS1-010506-1620	TS2-010506-1625	TS3-010506-1630	WS-010506-1640
Sediment Source	Lower Passaic River	Lower Passaic River	Lower Passaic River	Lower Passaic River	Lower Passaic River	Lower Passaic River	Lower Passaic River
Location Identification	SS2	RS	TS	TS1	TS2	TS3	WS
Date Collected	5/1/06	5/1/06	5/1/06	5/1/06	5/1/06	5/1/06	5/1/06
Matrix	Solid	Solid	Solid	Solid	Solid	Solid	Solid
Analyte/Methods (Units)							
Metals/SW6010B (mg/kg)							
Antimony	-	-	-	-	-	-	-
Arsenic	11.9	12.5	10.5	8.1	7.6	9.3	30.7
Barium	123	213	175	144	173	157	326
Beryllium	-	-	-	-	-	-	-
Cadmium	4.3	6.9	2.6	7.6	0.65	2.9	11.9
Chromium III	-	-	-	-	-	-	-
Chromium, Total	150	216	92.1	37.3	32	99.6	430
Copper	-	-	-	-	-	-	-
Lead	349	430	222	218	140	240	597
Mercury/SW7471A	3.5	4.6	3.6	0.83	1.2	3.7	12.3
Nickel	39.5	56.5	36.5	18.6	21.1	39.8	65.7
Selenium	2.6	2.9	1.9	1.0	0.75	2.1	4.7
Silver	3.3	7.1	2.7	0.46	0.88	3.1	13.4
Thallium	-	-	-	-	-	-	-
Vanadium	-	-	-	-	-	-	-
Zinc	659 B	763 B	349 B	221 B	169 B	387 B	1120 B

mg/kg milligrams per kilogram.

Bold Bolded result indicates positively identified compound.

- Not analyzed.

B Analyte detected in an associated blank.

D Sample dilution required for analysis; reported values reflect the dilution.

J Data are estimated due to associated quality control data.

T Analyte was positively identified but the reported concentration is estimated; reported concentration is less than the reporting limit, but greater than the method detection limit.

TABLE 9

METALS SOLID SAMPLE DATA SUMMARY
DEMONSTRATION TESTING AND FULL-SCALE OPERATION OF THE BIOGENESIS SEDIMENT DECONTAMINATION PROCESS
KEASBEY, NEW JERSEY
 (Page 47 of 58)

Field Sample Identification	PSS-020506-1600	SS1-020506-1605	SS2-020506-1610	RS-020506-1615	TS-020506-1635	STS-1-020506-1200	STS-2-020506-1500
Sediment Source	Lower Passaic River	Lower Passaic River	Lower Passaic River	Lower Passaic River	Lower Passaic River	Lower Passaic River	Lower Passaic River
Location Identification	PSS	SS1	SS2	RS	TS	TS	TS
Date Collected	5/2/06	5/2/06	5/2/06	5/2/06	5/2/06	5/2/06	5/2/06
Matrix	Solid	Solid	Solid	Solid	Solid	Solid	Solid
Analyte/Methods (Units)							
Metals/SW6010B (mg/kg)							
Antimony	-	-	-	-	-	-	-
Arsenic	14.9 J	15.7	17.5	9.8	7.7	6.9	6.9
Barium	244	146	184	164	137	125	126
Beryllium	-	-	-	-	-	-	-
Cadmium	8.2	5.3	6.6	5.0	2.9	2.7	2.7
Chromium III	-	-	-	-	-	-	-
Chromium, Total	251	157	269	171	97.3	86.3	88.2
Copper	-	-	-	-	-	-	-
Lead	505	297	461	336	241	232	231
Mercury/SW7471A	4.5	3.0	3.9	3.8	3.2	2.5	2.6
Nickel	64.1	48.3	57	44.7	38.2	36.8	36
Selenium	4.0 J	3.5	4.0	2.5	2.1	2.1	1.9
Silver	8.4	4.0	4.9	5.7	3.1	2.8	2.9
Thallium	-	-	-	-	-	-	-
Vanadium	-	-	-	-	-	-	-
Zinc	886 JB	1330 B	960 B	614 B	394 B	361 B	374 B

mg/kg milligrams per kilogram.

Bold Bolded result indicates positively identified compound.

- Not analyzed.

B Analyte detected in an associated blank.

D Sample dilution required for analysis; reported values reflect the dilution.

J Data are estimated due to associated quality control data.

T Analyte was positively identified but the reported concentration is estimated; reported concentration is less than the reporting limit, but greater than the method detection limit.

TABLE 9

METALS SOLID SAMPLE DATA SUMMARY
DEMONSTRATION TESTING AND FULL-SCALE OPERATION OF THE BIOGENESIS SEDIMENT DECONTAMINATION PROCESS
KEASBEY, NEW JERSEY
 (Page 48 of 58)

Field Sample Identification	TS1-020506-1620	TS2-020506-1625	TS3-020506-1630	WS-020506-1640	PSS-030506-1600	SS1-030506-1605	SS2-030506-1610
Sediment Source	Lower Passaic River	Lower Passaic River	Lower Passaic River	Lower Passaic River	Lower Passaic River	Lower Passaic River	Lower Passaic River
Location Identification	TS1	TS2	TS3	WS	PSS	SS1	SS2
Date Collected	5/2/06	5/2/06	5/2/06	5/2/06	5/3/06	5/3/06	5/3/06
Matrix	Solid	Solid	Solid	Solid	Solid	Solid	Solid
Analyte/Methods (Units)							
Metals/SW6010B (mg/kg)							
Antimony	-	-	-	-	-	-	-
Arsenic	15	4.0	8.0	21.2	10.9	14.4	15.5
Barium	171	88.6	141	339	179	134	168
Beryllium	-	-	-	-	-	-	-
Cadmium	3.8	1.8	3.2	12.8	7.4	6.8	7.7
Chromium III	-	-	-	-	-	-	-
Chromium, Total	127	59.6	102	465	195	155	212
Copper	-	-	-	-	-	-	-
Lead	484	274	247	604	412	314	447
Mercury/SW7471A	2.9	1.1	3.2	9.0	4.3	3.0	4.1
Nickel	44.4	25.5	39.3	69.1	48.6	45	82.4
Selenium	2.9	1.2	2.1	4.9	1.7 J	1.8	2.2
Silver	1.8	1.3	3.3	16.4	7.4	4.4	5.2
Thallium	-	-	-	-	-	-	-
Vanadium	-	-	-	-	-	-	-
Zinc	732 B	302 B	406 B	1290 B	677 J	749	883

mg/kg milligrams per kilogram.

Bold Bolded result indicates positively identified compound.

- Not analyzed.

B Analyte detected in an associated blank.

D Sample dilution required for analysis; reported values reflect the dilution.

J Data are estimated due to associated quality control data.

T Analyte was positively identified but the reported concentration is estimated; reported concentration is less than the reporting limit, but greater than the method detection limit.

TABLE 9

METALS SOLID SAMPLE DATA SUMMARY
DEMONSTRATION TESTING AND FULL-SCALE OPERATION OF THE BIOGENESIS SEDIMENT DECONTAMINATION PROCESS
KEASBEY, NEW JERSEY
 (Page 49 of 58)

Field Sample Identification	RS-030506-1615	STS-3-030506-1200	STS-4-030506-1400	TS-030506-1635	TS1-030506-1620	TS2-030506-1625	TS3-030506-1630
Sediment Source	Lower Passaic River	Lower Passaic River	Lower Passaic River	Lower Passaic River	Lower Passaic River	Lower Passaic River	Lower Passaic River
Location Identification	RS	TS	TS	TS	TS1	TS2	TS3
Date Collected	5/3/06	5/3/06	5/3/06	5/3/06	5/3/06	5/3/06	5/3/06
Matrix	Solid	Solid	Solid	Solid	Solid	Solid	Solid
Analyte/Methods (Units)							
Metals/SW6010B (mg/kg)							
Antimony	-	-	-	-	-	-	-
Arsenic	11	6.6	5.9	6.8	11.6	2.5	7.3
Barium	177	118	109	120	142	59.3	129
Beryllium	-	-	-	-	-	-	-
Cadmium	6.9	3.8	3.3	3.9	3.7	1.4	4.1
Chromium III	-	-	-	-	-	-	-
Chromium, Total	180	84.1	75	86.4	106	28.4	91.2
Copper	-	-	-	-	-	-	-
Lead	377	221	207	221	420	150	232
Mercury/SW7471A	4.0	2.7	2.3	2.6	2.8	0.99	2.9
Nickel	46.9	33.9	31.2	34	40.5	19.7	36.3
Selenium	1.1	0.68	0.59	0.74	0.9	<0.37	0.76
Silver	6.3	2.7	2.6	2.8	1.9	1.6	3.0
Thallium	-	-	-	-	-	-	-
Vanadium	-	-	-	-	-	-	-
Zinc	655	360	306	344	536	173	352

mg/kg milligrams per kilogram.

Bold Bolded result indicates positively identified compound.

- Not analyzed.

B Analyte detected in an associated blank.

D Sample dilution required for analysis; reported values reflect the dilution.

J Data are estimated due to associated quality control data.

T Analyte was positively identified but the reported concentration is estimated; reported concentration is less than the reporting limit, but greater than the method detection limit.

TABLE 9

METALS SOLID SAMPLE DATA SUMMARY
DEMONSTRATION TESTING AND FULL-SCALE OPERATION OF THE BIOGENESIS SEDIMENT DECONTAMINATION PROCESS
KEASBEY, NEW JERSEY
 (Page 50 of 58)

Field Sample Identification	WS-030506-1640	PSS-040506-1600	PSS-040506-1600B	PSS-040506-1600B	SS1-040506-1605	SS1-040506-1605B	SS2-040506-1610
Sediment Source	Lower Passaic River	Lower Passaic River	Lower Passaic River	Lower Passaic River	Lower Passaic River	Lower Passaic River	Lower Passaic River
Location Identification	WS	PSS	PSS	PSS Dup	SS1	SS1	SS2
Date Collected	5/3/06	5/4/06	5/4/06	5/4/06	5/4/06	5/4/06	5/4/06
Matrix	Solid	Solid	Solid	Solid	Solid	Solid	Solid
Analyte/Methods (Units)							
Metals/SW6010B (mg/kg)							
Antimony	-	-	-	-	-	-	-
Arsenic	20.5	10.6	11.1 JB	12 B	12.8	12.5 B	10.9
Barium	311	177	449	424	137	232	151
Beryllium	-	-	-	-	-	-	-
Cadmium	13.3	6.7	7.17	6.92	6.4	5.61	6.3
Chromium III	-	-	-	-	-	-	-
Chromium, Total	436	178	218	213	149	157	165
Copper	-	-	-	-	-	-	-
Lead	591	354 J	362	353	324	284	343
Mercury/SW7471A	9.3	4.6	-	-	2.9	-	3.9
Nickel	63.4	46.6	58.9	57.4	44.9	39.8	44.2
Selenium	2.2	0.86 J	<5	<5	1.2	<5	1.1
Silver	15.7	6.3	7.33 T	6.52 T	4.6	4.01 T	5.3
Thallium	-	-	-	-	-	-	-
Vanadium	-	-	-	-	-	-	-
Zinc	1070	620 JB	675	663	635 B	591	621 B

mg/kg milligrams per kilogram.

Bold Bolded result indicates positively identified compound.

- Not analyzed.

B Analyte detected in an associated blank.

D Sample dilution required for analysis; reported values reflect the dilution.

J Data are estimated due to associated quality control data.

T Analyte was positively identified but the reported concentration is estimated; reported concentration is less than the reporting limit, but greater than the method detection limit.

TABLE 9

METALS SOLID SAMPLE DATA SUMMARY
DEMONSTRATION TESTING AND FULL-SCALE OPERATION OF THE BIOGENESIS SEDIMENT DECONTAMINATION PROCESS
KEASBEY, NEW JERSEY
 (Page 51 of 58)

Field Sample Identification	SS2-040506-1610B	RS-040506-1615	RS-040506-1615B	TS-040506-1635	TS-040506-1635B	STS-5-040506-1200	STS-6-040506-1500
Sediment Source	Lower Passaic River	Lower Passaic River	Lower Passaic River	Lower Passaic River	Lower Passaic River	Lower Passaic River	Lower Passaic River
Location Identification	SS2	RS	RS	TS	TS	TS	TS
Date Collected	5/4/06	5/4/06	5/4/06	5/4/06	5/4/06	5/4/06	5/4/06
Matrix	Solid	Solid	Solid	Solid	Solid	Solid	Solid
Analyte/Methods (Units)							
Metals/SW6010B (mg/kg)							
Antimony	-	-	-	-	-	-	-
Arsenic	13.5 B	10.6	10.5 B	7.2	8.31 B	6.6	6.1
Barium	363	183	439	137	431	121	120
Beryllium	-	-	-	-	-	-	-
Cadmium	6.17	6.8	7.08	4.2	5.03	3.9	3.5
Chromium III	-	-	-	-	-	-	-
Chromium, Total	221	179	221	91.2	148	82.6	75.6
Copper	-	-	-	-	-	-	-
Lead	459	348	357	234	266	226	217
Mercury/SW7471A	-	4.2	-	3.3	-	2.7	2.4
Nickel	50.4	46.3	57.7	37.3	54.3	35.1	33.8
Selenium	<5	<0.77	<5	<0.38	<5	<0.38	<0.37
Silver	5.3 T	6.3	7.26 T	3.0	4.08 T	2.6	2.5
Thallium	-	-	-	-	-	-	-
Vanadium	-	-	-	-	-	-	-
Zinc	651	617 B	690	366 B	467	341 B	317 B

mg/kg milligrams per kilogram.

Bold Bolded result indicates positively identified compound.

- Not analyzed.

B Analyte detected in an associated blank.

D Sample dilution required for analysis; reported values reflect the dilution.

J Data are estimated due to associated quality control data.

T Analyte was positively identified but the reported concentration is estimated; reported concentration is less than the reporting limit, but greater than the method detection limit.

TABLE 9

METALS SOLID SAMPLE DATA SUMMARY
DEMONSTRATION TESTING AND FULL-SCALE OPERATION OF THE BIOGENESIS SEDIMENT DECONTAMINATION PROCESS
KEASBEY, NEW JERSEY
 (Page 52 of 58)

Field Sample Identification	TS1-040506-1620	TS1-040506-1620B	TS2-040506-1625	TS2-040506-1625B	TS3-040506-1630	TS3-040506-1630B	WS-040506-1640
Sediment Source	Lower Passaic River	Lower Passaic River	Lower Passaic River	Lower Passaic River	Lower Passaic River	Lower Passaic River	Lower Passaic River
Location Identification	TS1	TS1	TS2	TS2	TS3	TS3	WS
Date Collected	5/4/06	5/4/06	5/4/06	5/4/06	5/4/06	5/4/06	5/4/06
Matrix	Solid	Solid	Solid	Solid	Solid	Solid	Solid
Analyte/Methods (Units)							
Metals/SW6010B (mg/kg)							
Antimony	-	-	-	-	-	-	-
Arsenic	12.6	15.7 B	2.7	5.21 B	7.3	9.15 B	21.4
Barium	210	345	65.8	345	135	453	341
Beryllium	-	-	-	-	-	-	-
Cadmium	5.9	7.55	1.8	2.04	4.2	5.15	15.6
Chromium III	-	-	-	-	-	-	-
Chromium, Total	152	213	33.4	79.5	92.2	153	455
Copper	-	-	-	-	-	-	-
Lead	635	648	180	167	235	277	687
Mercury/SW7471A	3.7	-	1.2	-	3.0	-	9.6
Nickel	45.2	58.8	21.1	34.8	37	55.9	69.3
Selenium	1.5	<5	<0.35	<5	<0.38	<5	1.5
Silver	2.8	3.46 T	1.6	<10	3.0	4.12 T	16.7
Thallium	-	-	-	-	-	-	-
Vanadium	-	-	-	-	-	-	-
Zinc	822 B	932	193 B	216	371 B	479	1230 B

mg/kg milligrams per kilogram.

Bold Bolded result indicates positively identified compound.

- Not analyzed.

B Analyte detected in an associated blank.

D Sample dilution required for analysis; reported values reflect the dilution.

J Data are estimated due to associated quality control data.

T Analyte was positively identified but the reported concentration is estimated; reported concentration is less than the reporting limit, but greater than the method detection limit.

TABLE 9

METALS SOLID SAMPLE DATA SUMMARY
DEMONSTRATION TESTING AND FULL-SCALE OPERATION OF THE BIOGENESIS SEDIMENT DECONTAMINATION PROCESS
KEASBEY, NEW JERSEY
 (Page 53 of 58)

Field Sample Identification	WS-040506-1640B	SPC COMP-160506-1700	SPP COMP-170506-1030	TSA-260606-1350	TSA-260606-1350	TSE-260606-1355	TSF-260606-1400
Sediment Source	Lower Passaic River	All	All	Lower Passaic River	Lower Passaic River	Lower Passaic River	Lower Passaic River
Location Identification	WS	TSP	TSP	MSL	MSL	MSL	MSL
Date Collected	5/4/06	5/16/06	5/17/06	6/26/06	6/26/06	6/26/06	6/26/06
Matrix	Solid	Solid	Solid	Solid	Solid	Solid	Solid
Analyte/Methods (Units)							
Metals/SW6010B (mg/kg)							
Antimony	-	0.73 T	0.49 T	-	-	-	-
Arsenic	30.2 B	28.1	6.0	11.5 J	11.5	10.5	12.9
Barium	690	266	113	97.9	97.9	75.5	105
Beryllium	-	0.96	0.47	-	-	-	-
Cadmium	19.6	4.1	3.5	2.4 J	2.4 J	1.4 J	2.6 J
Chromium III	-	134	73.9	-	-	-	-
Chromium, Total	639	134	73.9	76.7	76.7	45.1	86.2
Copper	-	290	110	-	-	-	-
Lead	888	211	215	110 J	110 J	65.1 J	116 J
Mercury/SW7471A	-	4.4 D	2.7 D	2.3 DJ	2.3 DJ	1.5 DJ	3.1 DJ
Nickel	97.9	40.9	31.3	16.9 J	16.9	12.8	18.4
Selenium	<5	2.0	0.81	1.2	1.2	1.0	1.4
Silver	22.1	3.5	2.5	2.0 J	2.0	1.1	2.1
Thallium	-	<0.91	<0.71	-	-	-	-
Vanadium	-	38	24.3	-	-	-	-
Zinc	1720	328	306	168 JB	168 JB	104 JB	180 JB

mg/kg milligrams per kilogram.

Bold Bolded result indicates positively identified compound.

- Not analyzed.

B Analyte detected in an associated blank.

D Sample dilution required for analysis; reported values reflect the dilution.

J Data are estimated due to associated quality control data.

T Analyte was positively identified but the reported concentration is estimated; reported concentration is less than the reporting limit, but greater than the method detection limit.

TABLE 9

METALS SOLID SAMPLE DATA SUMMARY
DEMONSTRATION TESTING AND FULL-SCALE OPERATION OF THE BIOGENESIS SEDIMENT DECONTAMINATION PROCESS
KEASBEY, NEW JERSEY
 (Page 54 of 58)

Field Sample Identification	MSL01-040107-0905	MSL02-040107-0925	MSL03-040107-0940	MSL04-040107-0950	MSL05-040107-1000	MSL06-040107-1015	MSL07-040107-1025
Sediment Source	Lower Passaic River	Lower Passaic River	Lower Passaic River	Lower Passaic River	Lower Passaic River	Lower Passaic River	Lower Passaic River
Location Identification	MSL	MSL	MSL	MSL	MSL	MSL	MSL
Date Collected	1/4/07	1/4/07	1/4/07	1/4/07	1/4/07	1/4/07	1/4/07
Matrix	Solid	Solid	Solid	Solid	Solid	Solid	Solid
Analyte/Methods (Units)							
Metals/SW6010B (mg/kg)							
Antimony	-	-	-	-	-	-	-
Arsenic	7.5	8.4	8.6	7.9	7.7	9.3	8.1
Barium	81.6	96.9	102	92.6	89.1	103	82.2
Beryllium	-	-	-	-	-	-	-
Cadmium	0.98	1.0	1.0	1.0	0.92	1.0	0.89
Chromium III	-	-	-	-	-	-	-
Chromium, Total	36 B	35.5 B	39.1 B	36.9 B	35 B	40.2 B	38.2 B
Copper	-	-	-	-	-	-	-
Lead	80.9	85.3	89.9	84.8	77.3	92.8	77.5
Mercury/SW7471A	1.4	1.7 D	1.8 D	1.6 D	1.5 D	1.8 D	1.5 D
Nickel	15.5	17.3	17.8	16.6	16.2	17.7	14.6
Selenium	0.69	0.63	0.6	0.72	0.59	0.6	0.62
Silver	0.97	1.0	1.2	0.99	0.89	1.1	0.87
Thallium	-	-	-	-	-	-	-
Vanadium	-	-	-	-	-	-	-
Zinc	143 B	147 B	150 B	139 B	127 B	174 B	149 B

mg/kg milligrams per kilogram.

Bold Bolded result indicates positively identified compound.

- Not analyzed.

B Analyte detected in an associated blank.

D Sample dilution required for analysis; reported values reflect the dilution.

J Data are estimated due to associated quality control data.

T Analyte was positively identified but the reported concentration is estimated; reported concentration is less than the reporting limit, but greater than the method detection limit.

TABLE 9

METALS SOLID SAMPLE DATA SUMMARY
DEMONSTRATION TESTING AND FULL-SCALE OPERATION OF THE BIOGENESIS SEDIMENT DECONTAMINATION PROCESS
KEASBEY, NEW JERSEY
 (Page 55 of 58)

Field Sample Identification	MSL08-040107-1035	MSL09-040107-1045	MSL10-040107-1055	MSL11-040107-1055	PR-A-040107-0905	PR-B-040107-0940	PR-C-040107-1035
Sediment Source	Lower Passaic River	Lower Passaic River	Lower Passaic River	Lower Passaic River	Lower Passaic River	Lower Passaic River	Lower Passaic River
Location Identification	MSL	MSL	MSL	MSL	MSL	MSL	MSL
Date Collected	1/4/07	1/4/07	1/4/07	1/4/07	1/4/07	1/4/07	1/4/07
Matrix	Solid	Solid	Solid	Solid	Solid	Solid	Solid
Analyte/Methods (Units)							
Metals/SW6010B (mg/kg)							
Antimony	-	-	-	-	0.47 T	0.41 T	0.78
Arsenic	7.5	7.4	8.1	7.1	7.6	7.7	8.7
Barium	93.9	72.6	79.6	83.7	85.7	87.9	102
Beryllium	-	-	-	-	0.39 B	0.37 B	0.44 B
Cadmium	0.89	0.92	0.83	0.99	1.1	0.99	1.1
Chromium III	-	-	-	-	40.4	35.6	39.7
Chromium, Total	33.4 B	37.1 B	47.1 B	35.5 B	40.4 B	35.6 B	39.7 B
Copper	-	-	-	-	75.4	70.1	86.5
Lead	80.3	85.1	77.1	79.1	93.1	78.1	95.5
Mercury/SW7471A	1.7 D	1.5	1.5	1.5	1.5 D	1.8 D	1.7 D
Nickel	16	15.1	17.9	15.4	17.1	15.3	18.7
Selenium	0.55	0.41	0.46	0.44	0.58	0.59	0.62
Silver	0.94	1.0	0.91	1.0	1.1	0.94	1.1
Thallium	-	-	-	-	<0.62	<0.63	<0.64
Vanadium	-	-	-	-	16.3	14.4	16.2
Zinc	147 B	128 B	130 B	127 B	142 B	128 B	190 B

mg/kg milligrams per kilogram.

Bold Bolded result indicates positively identified compound.

- Not analyzed.

B Analyte detected in an associated blank.

D Sample dilution required for analysis; reported values reflect the dilution.

J Data are estimated due to associated quality control data.

T Analyte was positively identified but the reported concentration is estimated; reported concentration is less than the reporting limit, but greater than the method detection limit.

TABLE 9

METALS SOLID SAMPLE DATA SUMMARY
DEMONSTRATION TESTING AND FULL-SCALE OPERATION OF THE BIOGENESIS SEDIMENT DECONTAMINATION PROCESS
KEASBEY, NEW JERSEY
 (Page 56 of 58)

Field Sample Identification	PR-D-040107-1055	TSP1-112508-1410	TSP2-112508-1415	AD1-112508-1420	AD2-112508-1425	AD3-112508-1550	MS1-112508-1600
Sediment Source	Lower Passaic River	Lower Passaic River	Lower Passaic River	None	None	None	Lower Passaic River
Location Identification	MSL	TS	TS	AD	AD	AD	MSL
Date Collected	1/4/07	11/25/08	11/25/08	11/25/08	11/25/08	11/25/08	11/25/08
Matrix	Solid	Solid	Solid	Solid	Solid	Solid	Solid
Analyte/Methods (Units)							
Metals/SW6010B (mg/kg)							
Antimony	0.41 T	-	-	-	-	-	-
Arsenic	8.1	23.9 J	22.9	0.71	<0.68	2.1	10.6
Barium	90.7	137 J	136	0.91 T	29.0	89.6	72.0
Beryllium	0.4 B	-	-	-	-	-	-
Cadmium	1.0	1.4	1.4	<0.25	0.084 T	<0.25	0.73
Chromium III	39.9	-	-	-	-	-	-
Chromium, Total	39.9 B	100 J	80.3	8.4	1.2	15.2	49.4
Copper	74.3	-	-	-	-	-	-
Lead	83.4	127 J	127	0.84	1.1	3.0	58.2
Mercury/SW7471A	1.5 D	2.1 D	2.5 D	<0.017	0.036	0.020	1.1
Nickel	18.2	53.3 J	48.8	0.29 T	0.96 T	42.3	23.6
Selenium	0.5	0.94	0.94	<0.25	0.96	<0.51	0.60
Silver	1.0	1.4	1.5	<0.25	<0.34	<0.25	0.68
Thallium	<0.65	-	-	-	-	-	-
Vanadium	16.1	-	-	-	-	-	-
Zinc	136 B	205 J	196	2.9	25.5	60.4	106

mg/kg milligrams per kilogram.

Bold Bolded result indicates positively identified compound.

- Not analyzed.

B Analyte detected in an associated blank.

D Sample dilution required for analysis; reported values reflect the dilution.

J Data are estimated due to associated quality control data.

T Analyte was positively identified but the reported concentration is estimated; reported concentration is less than the reporting limit, but greater than the method detection limit.

TABLE 9

METALS SOLID SAMPLE DATA SUMMARY
DEMONSTRATION TESTING AND FULL-SCALE OPERATION OF THE BIOGENESIS SEDIMENT DECONTAMINATION PROCESS
KEASBEY, NEW JERSEY
 (Page 57 of 58)

Field Sample Identification	MS2-112508-1610	MS3-112508-1620	MS4-112508-1625	MS5-112508-1630	TS1-121908-0800	AD1-121908-0830	AD2-121908-0820
Sediment Source	Lower Passaic River	Lower Passaic River	Lower Passaic River	Lower Passaic River	Lower Passaic River	None	None
Location Identification	MSL	MSL	MSL	MSL	TS	AD	AD
Date Collected	11/25/08	11/25/08	11/25/08	11/25/08	12/19/08	12/19/08	12/19/08
Matrix	Solid	Solid	Solid	Solid	Solid	Solid	Solid
Analyte/Methods (Units)							
Metals/SW6010B (mg/kg)							
Antimony	-	-	-	-	-	-	-
Arsenic	18.3	3.5	10.6	5.8	26.2	4.6	4.7
Barium	105	26.1	83.4	40.3	145	17.5	99.3 J
Beryllium	-	-	-	-	-	-	-
Cadmium	1.2	0.31	0.61	0.25 T	1.2	0.18 T	<0.52
Chromium III	-	-	-	-	-	-	-
Chromium, Total	57.0	16.6	63.6	24.1	119	6.4	20.9
Copper	-	-	-	-	-	-	-
Lead	92.0	17.9	53.1	28.0	145	4.4	7.8
Mercury/SW7471A	1.5 D	0.33	0.81	0.52	2.5 D	<0.017	0.016 T
Nickel	35.2	8.5	57.0	13.2	55.9	7.1	51.4 J
Selenium	1.1	0.24 T	0.44	0.24 T	1.3	<0.53	<0.52
Silver	0.93	0.20 T	0.62	0.45	1.7	<0.26	<0.26
Thallium	-	-	-	-	-	-	-
Vanadium	-	-	-	-	-	-	-
Zinc	166	41.9	97.9	47.0	198	39.5	72.5 J

mg/kg milligrams per kilogram.

Bold Bolded result indicates positively identified compound.

- Not analyzed.

B Analyte detected in an associated blank.

D Sample dilution required for analysis; reported values reflect the dilution.

J Data are estimated due to associated quality control data.

T Analyte was positively identified but the reported concentration is estimated; reported concentration is less than the reporting limit, but greater than the method detection limit.

TABLE 9

METALS SOLID SAMPLE DATA SUMMARY
DEMONSTRATION TESTING AND FULL-SCALE OPERATION OF THE BIOGENESIS SEDIMENT DECONTAMINATION PROCESS
KEASBEY, NEW JERSEY
(Page 58 of 58)

Field Sample Identification	AD3-121908-0840	MS1-121908-0850
Sediment Source	None	Lower Passaic River
Location Identification	AD	MSL
Date Collected	12/19/08	12/19/08
Matrix	Solid	Solid
Analyte/Methods (Units)		
Metals/SW6010B (mg/kg)		
Antimony	-	-
Arsenic	<0.73	8.9
Barium	10.4 T	54.1
Beryllium	-	-
Cadmium	0.090 T	0.50
Chromium III	-	-
Chromium, Total	0.28 T	37.9
Copper	-	-
Lead	2.5	34.0
Mercury/SW7471A	0.036	0.46
Nickel	0.35 T	27.4
Selenium	0.86	0.54
Silver	<0.37	0.45
Thallium	-	-
Vanadium	-	-
Zinc	8.1	77.1

mg/kg milligrams per kilogram.

Bold Bolded result indicates positively identified compound.

- Not analyzed.

B Analyte detected in an associated blank.

D Sample dilution required for analysis; reported values reflect the dilution.

J Data are estimated due to associated quality control data.

T Analyte was positively identified but the reported concentration is estimated; reported concentration is less than the reporting limit, but greater than the method detection limit.

TABLE 10

**HEXAVALENT CHROMIUM SOLID SAMPLE DATA SUMMARY
 DEMONSTRATION TESTING AND FULL-SCALE OPERATION OF THE
 BIOGENESIS SEDIMENT DECONTAMINATION PROCESS
 KEASBEY, NEW JERSEY
 (Page 1 of 1)**

Field Sample Identification	Sediment Source	Location Identification	Date Collected	Matrix	Chromium, Hexavalent (mg/kg)
SPC COMP-160506-1700	All	TSP	5/16/06	Solid	<0.73
SPP COMP-170506-1030	All	TSP	5/17/06	Solid	<0.56
PR-A-040107-0905	Lower Passaic River	MSL	1/4/07	Solid	<0.5
PR-B-040107-0940	Lower Passaic River	MSL	1/4/07	Solid	<0.5
PR-C-040107-1035	Lower Passaic River	MSL	1/4/07	Solid	<0.51
PR-D-040107-1055	Lower Passaic River	MSL	1/4/07	Solid	<0.52

mg/kg milligrams per kilogram.

TABLE 11

**MERCURY BY EPA METHOD 245.5 SOLID SAMPLE DATA SUMMARY
 DEMONSTRATION TESTING AND FULL-SCALE OPERATION OF THE
 BIOGENESIS SEDIMENT DECONTAMINATION PROCESS
 KEASBEY, NEW JERSEY
 (Page 1 of 1)**

Field Sample Identification	Sediment Source	Location Identification	Date Collected	Matrix	Mercury (mg/kg)
PSS-040506-1600B	Lower Passaic River	PSS	5/4/06	Solid	4.24
PSS-040506-1600B	Lower Passaic River	PSS	5/4/06	Solid	3.96
SS1-040506-1605B	Lower Passaic River	SS1	5/4/06	Solid	3
SS2-040506-1610B	Lower Passaic River	SS2	5/4/06	Solid	3.71
RS-040506-1615B	Lower Passaic River	RS	5/4/06	Solid	4.39
TS-040506-1635B	Lower Passaic River	TS	5/4/06	Solid	3.03
TS1-040506-1620B	Lower Passaic River	TS1	5/4/06	Solid	3.48
TS2-040506-1625B	Lower Passaic River	TS2	5/4/06	Solid	0.829
TS3-040506-1630B	Lower Passaic River	TS3	5/4/06	Solid	2.95
WS-040506-1640B	Lower Passaic River	WS	5/4/06	Solid	9.29

mg/kg milligrams per kilogram.

Bold Bolded result indicates positively identified compound.

TABLE 12
CYANIDE SOLID SAMPLE DATA SUMMARY
DEMONSTRATION TESTING AND FULL-SCALE OPERATION OF THE
BIOGENESIS SEDIMENT DECONTAMINATION PROCESS
KEASBEY, NEW JERSEY
(Page 1 of 1)

Field Sample Identification	Sediment Source	Location Identification	Date Collected	Matrix	Cyanide (mg/kg)
SPC COMP-160506	All	TSP	5/15/06	Solid	2.2
SPP COMP-170506	All	TSP	5/17/06	Solid	0.69
CARBON TANKS	None	CAR	5/10/06	Solid	10.3
MSL01-040107-0905	Lower Passaic River	MSL	1/4/07	Solid	<0.62
MSL02-040107-0925	Lower Passaic River	MSL	1/4/07	Solid	<0.62
MSL03-040107-0940	Lower Passaic River	MSL	1/4/07	Solid	6.3
MSL04-040107-0950	Lower Passaic River	MSL	1/4/07	Solid	<0.62
MSL05-040107-1000	Lower Passaic River	MSL	1/4/07	Solid	<0.61
MSL06-040107-1015	Lower Passaic River	MSL	1/4/07	Solid	<0.64
MSL07-040107-1025	Lower Passaic River	MSL	1/4/07	Solid	<0.62
MSL08-040107-1035	Lower Passaic River	MSL	1/4/07	Solid	<0.62
MSL09-040107-1045	Lower Passaic River	MSL	1/4/07	Solid	<0.65
MSL10-040107-1055	Lower Passaic River	MSL	1/4/07	Solid	<0.64
MSL11-040107-1055	Lower Passaic River	MSL	1/4/07	Solid	<0.62
PR-A-040107-0905	Lower Passaic River	MSL	1/4/07	Solid	<0.62
PR-B-040107-0940	Lower Passaic River	MSL	1/4/07	Solid	<0.63
PR-C-040107-1035	Lower Passaic River	MSL	1/4/07	Solid	<0.64
PR-D-040107-1055	Lower Passaic River	MSL	1/4/07	Solid	<0.65
TS1-12908-0800	Lower Passaic River	TS	12/19/08	Solid	0.48 T
AD1-121908-0830	None	AD	12/19/08	Solid	<0.53
AD2-121908-0820	None	AD	12/19/08	Solid	<0.52
AD3-121908-0840	None	AD	12/19/08	Solid	<0.97 D
MS1-121908-0850	Lower Passaic River	MSL	12/19/08	Solid	0.45 T

mg/kg milligrams per kilogram.

T Analyte was positively identified but the reported concentration is estimated; reported concentration is less than the reporting limit, but greater than the method detection limit.

Bold Bolded result indicates positively identified compound.

TABLE 13

**TOTAL ORGANIC CARBON SOLID SAMPLE DATA SUMMARY
 DEMONSTRATION TESTING AND FULL-SCALE OPERATION OF THE
 BIOGENESIS SEDIMENT DECONTAMINATION PROCESS
 KEASBEY, NEW JERSEY**

(Page 1 of 13)

Field Sample Identification	Sediment Source	Location Identification	Date Collected	Matrix	TOC (mg/kg)
TS-211205-1715	Raritan River	TS	12/21/05	Solid	14300
WS1-211205-1800	Raritan River	WS	12/21/05	Solid	38500
TS-291205-1100	Raritan River	TS	12/29/05	Solid	15900
WS-291205-1110	Raritan River	WS	12/29/05	Solid	40400
RS-030106-1600	Raritan River	RS	1/3/06	Solid	23600
TS-030106-1645	Raritan River	TS	1/3/06	Solid	14800
WS1-030106-1615	Raritan River	WS1	1/3/06	Solid	38900
WS2-030106-1630	Raritan River	WS2	1/3/06	Solid	35700
RS-040106-1300	Raritan River	RS	1/4/06	Solid	25200
TS-040106-1100	Raritan River	TS	1/4/06	Solid	16700
WS-040106-1400	Raritan River	WS	1/4/06	Solid	41800
RS-050106-1500	Raritan River	RS	1/5/06	Solid	21500
TS-050106-1505	Raritan River	TS	1/5/06	Solid	16500
WS-050106-1510	Raritan River	WS	1/5/06	Solid	38600
RS-060106-1531	Raritan River	RS	1/6/06	Solid	28000
TS-060106-1532	Raritan River	TS	1/6/06	Solid	17200
WS-060106-1533	Raritan River	WS	1/6/06	Solid	41900
RS-090106-1500	Raritan River	RS	1/9/06	Solid	5630
TS-090106-1501	Raritan River	TS	1/9/06	Solid	19400
WS-090106-1502	Raritan River	WS	1/9/06	Solid	42500
RS-100106-1600	Raritan River	RS	1/10/06	Solid	23600
TS-100106-1601	Raritan River	TS	1/10/06	Solid	85900
WS-100106-1602	Raritan River	WS	1/10/06	Solid	31400
RS-110106-1630	Raritan River	RS	1/11/06	Solid	23300
TS-110106-1631	Raritan River	TS	1/11/06	Solid	37900
RS-120106-1630	Raritan River	RS	1/12/06	Solid	25000
TS-120106-1601	Raritan River	TS	1/12/06	Solid	33900
WS-120106-1602	Raritan River	WS	1/12/06	Solid	36600
RS-190106-1600	Lower Passaic River	RS	1/19/06	Solid	45700
TS-190106-1601	Lower Passaic River	TS	1/19/06	Solid	72200
WS-190106-1602	Lower Passaic River	WS	1/19/06	Solid	73400
WS-190106-1602	Lower Passaic River	WS	1/19/06	Solid	74600
RS-240106-1530	Lower Passaic River	RS	1/24/06	Solid	60900

TABLE 13

**TOTAL ORGANIC CARBON SOLID SAMPLE DATA SUMMARY
 DEMONSTRATION TESTING AND FULL-SCALE OPERATION OF THE
 BIOGENESIS SEDIMENT DECONTAMINATION PROCESS
 KEASBEY, NEW JERSEY**

(Page 2 of 13)

Field Sample Identification	Sediment Source	Location Identification	Date Collected	Matrix	TOC (mg/kg)
TS-240106-1630	Lower Passaic River	TS	1/24/06	Solid	41900
RS-270106-1400	Lower Passaic River	RS	1/27/06	Solid	79500
RS-270106-1400	Lower Passaic River	RS	1/27/06	Solid	73900
TS-270106-1401	Lower Passaic River	TS	1/27/06	Solid	55300
TS-270106-1530	Lower Passaic River	TS	1/27/06	Solid	40900
WS-270106-1402	Lower Passaic River	WS	1/27/06	Solid	107000
WS-270106-1531	Lower Passaic River	WS	1/27/06	Solid	109000
RS-300106-1700	Raritan River	RS	1/30/06	Solid	42900
WS2-300106-1702	Raritan River	WS2	1/30/06	Solid	58700
RS-310106-1700	Raritan River	RS	1/31/06	Solid	22400
RS-310106-1700	Raritan River	RS	1/31/06	Solid	24400
TS-310106-1701	Raritan River	TS	1/31/06	Solid	26600
WS-310106-1702	Raritan River	WS	1/31/06	Solid	41100
RS-010206-1600	Raritan River	RS	2/1/06	Solid	24400
TS-010206-1601	Raritan River	TS	2/1/06	Solid	22500
WS-010206-1602	Raritan River	WS	2/1/06	Solid	41100
RS-020206-1800	Raritan River	RS	2/2/06	Solid	23800
RS-020206-1800	Raritan River	RS	2/2/06	Solid	19800
TS-020206-1801	Raritan River	TS	2/2/06	Solid	26800
WS-020206-1802	Raritan River	WS	2/2/06	Solid	40000
RS-030206-1200	Raritan River	RS	2/3/06	Solid	24200
TS-030206-1201	Raritan River	TS	2/3/06	Solid	27700
WS-030206-1202	Raritan River	WS	2/3/06	Solid	41500
RS-060206-1930	Raritan River	RS	2/6/06	Solid	24300
TS-060206-1931	Raritan River	TS	2/6/06	Solid	23200
WS-060206-1932	Raritan River	WS	2/6/06	Solid	42100
SP-070206-1445	Raritan River	PPS	2/7/06	Solid	41700
RS-070206-1630	Raritan River	RS	2/7/06	Solid	26500
TS-070206-1631	Raritan River	TS	2/7/06	Solid	23600
TS-070206-1631 DRIED	Raritan River	TS	2/7/06	Solid	23800 H
WS-070206-1632	Raritan River	WS	2/7/06	Solid	41400
RS-080206-1700	Raritan River	RS	2/8/06	Solid	32400
TS-080206-1701	Raritan River	TS	2/8/06	Solid	22100

10/29/09

Table 13 TOC - Solids.xls

TABLE 13

**TOTAL ORGANIC CARBON SOLID SAMPLE DATA SUMMARY
 DEMONSTRATION TESTING AND FULL-SCALE OPERATION OF THE
 BIOGENESIS SEDIMENT DECONTAMINATION PROCESS
 KEASBEY, NEW JERSEY**

(Page 3 of 13)

Field Sample Identification	Sediment Source	Location Identification	Date Collected	Matrix	TOC (mg/kg)
WS-080206-1702	Raritan River	WS	2/8/06	Solid	42100
RS-090206-2300	Arthur Kill	RS	2/9/06	Solid	25800
TS-090206-2301	Arthur Kill	TS	2/9/06	Solid	23400
WS-090206-2302	Arthur Kill	WS	2/9/06	Solid	55100
RS-130206-1700	Lower Passaic River	RS	2/13/06	Solid	137000
TS-130206-1701	Lower Passaic River	TS	2/13/06	Solid	29400
WS-130206-1702	Lower Passaic River	WS	2/13/06	Solid	64000
WS-130206-1702	Lower Passaic River	WS	2/13/06	Solid	67100
RS-140206-1330	Arthur Kill	RS	2/14/06	Solid	40800
RS-140206-1330	Arthur Kill	RS	2/14/06	Solid	36800
TS-140206-1331	Arthur Kill	TS	2/14/06	Solid	34600
WS-140206-1332	Arthur Kill	WS	2/14/06	Solid	68200
RS-160206-1500	Arthur Kill	RS	2/16/06	Solid	33500
TS-160206-1501	Arthur Kill	TS	2/16/06	Solid	29200
WS-160206-1502	Arthur Kill	WS	2/16/06	Solid	71000
RS-170206-1100	Arthur Kill	RS	2/17/06	Solid	37100
TS-170206-1101	Arthur Kill	TS	2/17/06	Solid	18600
WS-170206-1102	Arthur Kill	WS	2/17/06	Solid	55700
WS-170206-1102	Arthur Kill	WS	2/17/06	Solid	60400
TS-230206-0930	Arthur Kill	TS	2/23/06	Solid	23600
TS-230206-0930 DRIED	Arthur Kill	TS	2/23/06	Solid	20400
RS-270206-1400	Lower Passaic River	RS	2/27/06	Solid	50400
TS-270206-1350	Lower Passaic River	TS	2/27/06	Solid	25400
TS-270206-1630	Lower Passaic River	TS	2/27/06	Solid	28900
RS-280206-1700	Arthur Kill	RS	2/28/06	Solid	33900
TS-280206-1705	Arthur Kill	TS	2/28/06	Solid	26800
WS-280206-1710	Arthur Kill	WS	2/28/06	Solid	79400
RS-010306-1700	Arthur Kill	RS	3/1/06	Solid	40000
TS-010306-1705	Arthur Kill	TS	3/1/06	Solid	39000
WS-010306-1710	Arthur Kill	WS	3/1/06	Solid	68700
RS-020306-1700	Arthur Kill	RS	3/2/06	Solid	38000
RS-020306-1700	Arthur Kill	RS	3/2/06	Solid	37600
SS-020306-1400	Arthur Kill	SS1	3/2/06	Solid	133000

TABLE 13

**TOTAL ORGANIC CARBON SOLID SAMPLE DATA SUMMARY
 DEMONSTRATION TESTING AND FULL-SCALE OPERATION OF THE
 BIOGENESIS SEDIMENT DECONTAMINATION PROCESS
 KEASBEY, NEW JERSEY**

(Page 4 of 13)

Field Sample Identification	Sediment Source	Location Identification	Date Collected	Matrix	TOC (mg/kg)
TS-020306-1705	Arthur Kill	TS	3/2/06	Solid	31900
WS-020306-1710	Arthur Kill	WS	3/2/06	Solid	75500
RS-030306-1200	Arthur Kill	RS	3/3/06	Solid	46800
TS-030306-1205	Arthur Kill	TS	3/3/06	Solid	38900
WS-030306-1210	Arthur Kill	WS	3/3/06	Solid	78000
SEC SCREEN-INFLUENT	Lower Passaic River	PSS	3/16/06	Solid	59500 B
SEC SCREEN-SCREENINGS	Lower Passaic River	SS1	3/16/06	Solid	225000 B
SEC SCREEN-EFFLUENT	Lower Passaic River	RS	3/16/06	Solid	59800 B
HYDROCYCLONES	Lower Passaic River	TS2	3/16/06	Solid	14000
SCALPING SCREEN	Lower Passaic River	TS1	3/16/06	Solid	200000 B
HYDROCYCLONE OVERFLOW	Lower Passaic River	HO	3/16/06	Solid	59300
PSS-210306-0915	Arthur Kill	PSS	3/21/06	Solid	45300
SS1-210306-0920	Arthur Kill	SS1	3/21/06	Solid	90000
SS2-210306-0925	Arthur Kill	SS2	3/21/06	Solid	61700
RS-210306-0930	Arthur Kill	RS	3/21/06	Solid	71700
TS-210306-1030	Arthur Kill	TS	3/21/06	Solid	24000
TS1-210306-1035	Arthur Kill	TS1	3/21/06	Solid	52200
TS2-210306-1040	Arthur Kill	TS2	3/21/06	Solid	23400
TS3-210306-1045	Arthur Kill	TS3	3/21/06	Solid	33600
TS4-210306-1130	Arthur Kill	TS	3/21/06	Solid	24900
TS5-210306-1135	Arthur Kill	TS1	3/21/06	Solid	56900
TS6-210306-1140	Arthur Kill	TS2	3/21/06	Solid	10600
TS7-210306-1145	Arthur Kill	TS3	3/21/06	Solid	29200
TS7-210306-1145	Arthur Kill	TS3	3/21/06	Solid	29200
TS-220306-1000	Arthur Kill	TS	3/22/06	Solid	29600
TS1-220306-1005	Arthur Kill	TS1	3/22/06	Solid	125000
TS2-220306-1010	Arthur Kill	TS2	3/22/06	Solid	19400
TS3-220306-1015	Arthur Kill	TS3	3/22/06	Solid	33800
PSS-230306-1530	Lower Passaic River	PSS	3/23/06	Solid	85800
SS1-230306-1535	Lower Passaic River	SS1	3/23/06	Solid	865000
SS2-230306-1540	Lower Passaic River	SS2	3/23/06	Solid	366000
RS-230306-1545	Lower Passaic River	RS	3/23/06	Solid	89900
TS-230306-0930	Arthur Kill	TS	3/23/06	Solid	29500

10/29/09

Table 13 TOC - Solids.xls

TABLE 13

**TOTAL ORGANIC CARBON SOLID SAMPLE DATA SUMMARY
 DEMONSTRATION TESTING AND FULL-SCALE OPERATION OF THE
 BIOGENESIS SEDIMENT DECONTAMINATION PROCESS
 KEASBEY, NEW JERSEY**

(Page 5 of 13)

Field Sample Identification	Sediment Source	Location Identification	Date Collected	Matrix	TOC (mg/kg)
TSP-230306-1730	Lower Passaic River	TS	3/23/06	Solid	30300
PSS-270306-1100	Lower Passaic River	PSS	3/27/06	Solid	83100
TS-270306-1320	Lower Passaic River	TS	3/27/06	Solid	44100
CENTRATE 1	Lower Passaic River	C1	3/30/06	Solid	116000
PSS-300306-1300	Lower Passaic River	PSS	3/30/06	Solid	36200
PSS-300306-1300	Lower Passaic River	PSS	3/30/06	Solid	55200
SS1-300306-1305	Lower Passaic River	SS1	3/30/06	Solid	103000
SS2-300306-1310	Lower Passaic River	SS2	3/30/06	Solid	62100
RS-300306-1315	Lower Passaic River	RS	3/30/06	Solid	38300
TS-300306-1320	Lower Passaic River	TS	3/30/06	Solid	33600
TS1-300306-1325	Lower Passaic River	TS1	3/30/06	Solid	105000
TS2-300306-1330	Lower Passaic River	TS2	3/30/06	Solid	22100
TS3-300306-1335	Lower Passaic River	TS3	3/30/06	Solid	41000
WS-300306-1345	Lower Passaic River	WS	3/30/06	Solid	110000
PSS-030406-1500	Arthur Kill	PSS	4/3/06	Solid	31300
SS1-030406-1505	Arthur Kill	SS1	4/3/06	Solid	59900
SS2-030406-1510	Arthur Kill	SS2	4/3/06	Solid	158000
RS-030406-1515	Arthur Kill	RS	4/3/06	Solid	37700
FD-431520	Arthur Kill	RS	4/3/06	Solid	40400
INF-431525	Arthur Kill	RS	4/3/06	Solid	31400
TS-030406-1540	Arthur Kill	TS	4/3/06	Solid	34900
TS1-030406-1525	Arthur Kill	TS1	4/3/06	Solid	100000
TS2-030406-1530	Arthur Kill	TS2	4/3/06	Solid	95400
TS3-030406-1535	Arthur Kill	TS3	4/3/06	Solid	41400
WS-030406-1600	Arthur Kill	WS	4/3/06	Solid	91700
PSS-040406-1200	Arthur Kill	PSS	4/4/06	Solid	27600
SS1-040406-1205	Arthur Kill	SS1	4/4/06	Solid	68700
SS2-040406-1210	Arthur Kill	SS2	4/4/06	Solid	141000
RS-040406-1215	Arthur Kill	RS	4/4/06	Solid	38900
TS-040406-1240	Arthur Kill	TS	4/4/06	Solid	36800
TS1-040406-1225	Arthur Kill	TS1	4/4/06	Solid	44900
TS2-040406-1230	Arthur Kill	TS2	4/4/06	Solid	62600
TS3-040406-1235	Arthur Kill	TS3	4/4/06	Solid	31700

TABLE 13

**TOTAL ORGANIC CARBON SOLID SAMPLE DATA SUMMARY
 DEMONSTRATION TESTING AND FULL-SCALE OPERATION OF THE
 BIOGENESIS SEDIMENT DECONTAMINATION PROCESS
 KEASBEY, NEW JERSEY**

(Page 6 of 13)

Field Sample Identification	Sediment Source	Location Identification	Date Collected	Matrix	TOC (mg/kg)
WS-040406-1300	Arthur Kill	WS	4/4/06	Solid	71100
WS-040406-1300	Arthur Kill	WS	4/4/06	Solid	66400
PSS-050406-1200	Arthur Kill	PSS	4/5/06	Solid	30200
SS1-050406-1205	Arthur Kill	SS1	4/5/06	Solid	72000
SS2-050406-1210	Arthur Kill	SS2	4/5/06	Solid	59400
RS-050406-1215	Arthur Kill	RS	4/5/06	Solid	36000
TS-050406-1240	Arthur Kill	TS	4/5/06	Solid	56300
TS1-050406-1225	Arthur Kill	TS1	4/5/06	Solid	57200
TS2-050406-1230	Arthur Kill	TS2	4/5/06	Solid	191000
TS3-050406-1235	Arthur Kill	TS3	4/5/06	Solid	34600
WS-050406-1300	Arthur Kill	WS	4/5/06	Solid	82600
PSS-060406-1200	Arthur Kill	PSS	4/6/06	Solid	44600
PSS-060406-1200	Arthur Kill	PSS	4/6/06	Solid	34400
SS1-060406-1205	Arthur Kill	SS1	4/6/06	Solid	36800
SS2-060406-1210	Arthur Kill	SS2	4/6/06	Solid	66300
RS-060406-1215	Arthur Kill	RS	4/6/06	Solid	46100
TS-060406-1240	Arthur Kill	TS	4/6/06	Solid	28500
TS1-060406-1225	Arthur Kill	TS1	4/6/06	Solid	84700
TS2-060406-1230	Arthur Kill	TS2	4/6/06	Solid	16500
TS3-060406-1235	Arthur Kill	TS3	4/6/06	Solid	36900
WS-060406-1300	Arthur Kill	WS	4/6/06	Solid	109000
PSS-100406-1510	Arthur Kill	PSS	4/10/06	Solid	38900
SS1-100406-1515	Arthur Kill	SS1	4/10/06	Solid	83700
SS2-100406-1520	Arthur Kill	SS2	4/10/06	Solid	162000
RS-100406-1525	Arthur Kill	RS	4/10/06	Solid	153000
RS-100406-1525	Arthur Kill	RS	4/10/06	Solid	131000
TS-100406-1615	Arthur Kill	TS	4/10/06	Solid	24100
TS1-100406-1600	Arthur Kill	TS1	4/10/06	Solid	23400
TS2-100406-1605	Arthur Kill	TS2	4/10/06	Solid	21000
TS3-100406-1610	Arthur Kill	TS3	4/10/06	Solid	24400
WS-100406-1630	Arthur Kill	WS	4/10/06	Solid	74200
PSS-110406-1800	Arthur Kill	PSS	4/11/06	Solid	44400 J
SS1-110406-1805	Arthur Kill	SS1	4/11/06	Solid	99500 J

TABLE 13

**TOTAL ORGANIC CARBON SOLID SAMPLE DATA SUMMARY
 DEMONSTRATION TESTING AND FULL-SCALE OPERATION OF THE
 BIOGENESIS SEDIMENT DECONTAMINATION PROCESS
 KEASBEY, NEW JERSEY
 (Page 7 of 13)**

Field Sample Identification	Sediment Source	Location Identification	Date Collected	Matrix	TOC (mg/kg)
SS2-110406-1810	Arthur Kill	SS2	4/11/06	Solid	127000 J
RS-110406-1815	Arthur Kill	RS	4/11/06	Solid	49700 J
TS-110406-1835	Arthur Kill	TS	4/11/06	Solid	23100
TS1-110406-1820	Arthur Kill	TS1	4/11/06	Solid	53500 J
TS2-110406-1825	Arthur Kill	TS2	4/11/06	Solid	9370
TS3-110406-1830	Arthur Kill	TS3	4/11/06	Solid	26600
WS-110406-1840	Arthur Kill	WS	4/11/06	Solid	91000
PSS-120406-1800	Arthur Kill	PSS	4/12/06	Solid	32300
PSS-120406-1800	Arthur Kill	PSS	4/12/06	Solid	35200
SS1-120406-1805	Arthur Kill	SS1	4/12/06	Solid	50100
SS2-120406-1810	Arthur Kill	SS2	4/12/06	Solid	88600
RS-120406-1815	Arthur Kill	RS	4/12/06	Solid	39800
TS-120406-1835	Arthur Kill	TS	4/12/06	Solid	32700
TS1-120406-1820	Arthur Kill	TS1	4/12/06	Solid	54100
TS2-120406-1825	Arthur Kill	TS2	4/12/06	Solid	20200
TS3-120406-1830	Arthur Kill	TS3	4/12/06	Solid	30300
WS-120406-1840	Arthur Kill	WS	4/12/06	Solid	90600
PSS-130406-1700	Arthur Kill	PSS	4/13/06	Solid	37700
PSS-130406-1700	Arthur Kill	PSS	4/13/06	Solid	42600
SS1-130406-1705	Arthur Kill	SS1	4/13/06	Solid	90300
SS2-130406-1710	Arthur Kill	SS2	4/13/06	Solid	121000
RS-130406-1715	Arthur Kill	RS	4/13/06	Solid	57400
TS-130406-1735	Arthur Kill	TS	4/13/06	Solid	25300
TS1-130406-1720	Arthur Kill	TS1	4/13/06	Solid	93100
TS2-130406-1725	Arthur Kill	TS2	4/13/06	Solid	25100
TS3-130406-1730	Arthur Kill	TS3	4/13/06	Solid	28400
WS-130406-1740	Arthur Kill	WS	4/13/06	Solid	81400
PSS-170406-1700	Arthur Kill	PSS	4/17/06	Solid	41700 J
PSS-170406-1700	Arthur Kill	PSS	4/17/06	Solid	57700
SS1-170406-1715	Arthur Kill	SS1	4/17/06	Solid	110000
SS2-170406-1720	Arthur Kill	SS2	4/17/06	Solid	220000
RS-170406-1725	Arthur Kill	RS	4/17/06	Solid	41200
TS-170406-1745	Arthur Kill	TS	4/17/06	Solid	30400

TABLE 13

**TOTAL ORGANIC CARBON SOLID SAMPLE DATA SUMMARY
 DEMONSTRATION TESTING AND FULL-SCALE OPERATION OF THE
 BIOGENESIS SEDIMENT DECONTAMINATION PROCESS
 KEASBEY, NEW JERSEY**

(Page 8 of 13)

Field Sample Identification	Sediment Source	Location Identification	Date Collected	Matrix	TOC (mg/kg)
TS1-170406-1730	Arthur Kill	TS1	4/17/06	Solid	58900
TS2-170406-1735	Arthur Kill	TS2	4/17/06	Solid	29200
TS3-170406-1740	Arthur Kill	TS3	4/17/06	Solid	28500
WS-170406-1745	Arthur Kill	WS	4/17/06	Solid	85600
PSS-180406-1700	Arthur Kill	PSS	4/18/06	Solid	32600
SS1-180406-1705	Arthur Kill	SS1	4/18/06	Solid	139000
SS2-180406-1710	Arthur Kill	SS2	4/18/06	Solid	143000
RS-180406-1715	Arthur Kill	RS	4/18/06	Solid	33500
TS-180406-1735	Arthur Kill	TS	4/18/06	Solid	22000
TS1-180406-1720	Arthur Kill	TS1	4/18/06	Solid	71400
TS2-180406-1725	Arthur Kill	TS2	4/18/06	Solid	15900
TS3-180406-1730	Arthur Kill	TS3	4/18/06	Solid	26000
WS-180406-1740	Arthur Kill	WS	4/18/06	Solid	72300
PSS-190406-0900	Arthur Kill	PSS	4/19/06	Solid	34600
SS1-190406-0905	Arthur Kill	SS1	4/19/06	Solid	139000
SS2-190406-0910	Arthur Kill	SS2	4/19/06	Solid	71300
RS-190406-0915	Arthur Kill	RS	4/19/06	Solid	49000
RS-190406-0915	Arthur Kill	RS	4/19/06	Solid	42800
TS-190406-0845	Arthur Kill	TS	4/19/06	Solid	22700
TS1-190406-0845	Arthur Kill	TS1	4/19/06	Solid	42400
TS2-190406-0845	Arthur Kill	TS2	4/19/06	Solid	17200
TS3-190406-0845	Arthur Kill	TS3	4/19/06	Solid	25500
WS-190406-1600	Arthur Kill	WS	4/19/06	Solid	75600
PSS-200406-1600	Arthur Kill	PSS	4/20/06	Solid	32200
SS1-200406-1605	Arthur Kill	SS1	4/20/06	Solid	131000
SS2-200406-1610	Arthur Kill	SS2	4/20/06	Solid	110000 J
RS-200406-1615	Arthur Kill	RS	4/20/06	Solid	10800 J
TS-200406-1635	Arthur Kill	TS	4/20/06	Solid	20000 J
TS1-200406-1620	Arthur Kill	TS1	4/20/06	Solid	63700 J
TS2-200406-1625	Arthur Kill	TS2	4/20/06	Solid	8600 J
TS3-200406-1630	Arthur Kill	TS3	4/20/06	Solid	27400 J
WS-200406-1640	Arthur Kill	WS	4/20/06	Solid	75400
PSS-210406-1400	Arthur Kill	PSS	4/21/06	Solid	65300 J

TABLE 13

**TOTAL ORGANIC CARBON SOLID SAMPLE DATA SUMMARY
 DEMONSTRATION TESTING AND FULL-SCALE OPERATION OF THE
 BIOGENESIS SEDIMENT DECONTAMINATION PROCESS
 KEASBEY, NEW JERSEY**

(Page 9 of 13)

Field Sample Identification	Sediment Source	Location Identification	Date Collected	Matrix	TOC (mg/kg)
SS1-210406-1405	Arthur Kill	SS1	4/21/06	Solid	490000 J
SS2-210406-1410	Arthur Kill	SS2	4/21/06	Solid	53200 J
RS-210406-1415	Arthur Kill	RS	4/21/06	Solid	135000 J
TS-210406-1435	Arthur Kill	TS	4/21/06	Solid	39500
TS1-210406-1420	Arthur Kill	TS1	4/21/06	Solid	48700 J
TS2-210406-1425	Arthur Kill	TS2	4/21/06	Solid	21100 J
TS3-210406-1430	Arthur Kill	TS3	4/21/06	Solid	30000
WS-210406-1440	Arthur Kill	WS	4/21/06	Solid	79200
WS-210406-1440	Arthur Kill	WS	4/21/06	Solid	143000
PSS-240406-1600	Arthur Kill	PSS	4/24/06	Solid	31300
PSS-240406-1600	Arthur Kill	PSS	4/24/06	Solid	26600
RS-240406-1615	Arthur Kill	RS	4/24/06	Solid	28900
INF1-250406-1845	Arthur Kill	RS	4/24/06	Solid	59100 J
INF1-260406-1345	Arthur Kill	RS	4/24/06	Solid	51600
SS1-240406-1605	Arthur Kill	SS1	4/24/06	Solid	227000
SS2-240406-1610	Arthur Kill	SS2	4/24/06	Solid	138000
TS-240406-1635	Arthur Kill	TS	4/24/06	Solid	36200
TS1-240406-1620	Arthur Kill	TS1	4/24/06	Solid	48900
TS2-240406-1625	Arthur Kill	TS2	4/24/06	Solid	8560
TS3-240406-1630	Arthur Kill	TS3	4/24/06	Solid	28600
WS-240406-1640	Arthur Kill	WS	4/24/06	Solid	80100
PSS-250406-1800	Arthur Kill	PSS	4/25/06	Solid	32500
SS2-250406-1810	Arthur Kill	SS2	4/25/06	Solid	148000
RS-250406-1815	Arthur Kill	RS	4/25/06	Solid	208000
TS-250406-1835	Arthur Kill	TS	4/25/06	Solid	31300
TS1-250406-1820	Arthur Kill	TS1	4/25/06	Solid	83800
TS2-250406-1825	Arthur Kill	TS2	4/25/06	Solid	8740
TS3-250406-1830	Arthur Kill	TS3	4/25/06	Solid	29500
WS-250406-1840	Arthur Kill	WS	4/25/06	Solid	84300
PSS-260406-1300	Arthur Kill	PSS	4/26/06	Solid	51800
PSS-260406-1300	Arthur Kill	PSS	4/26/06	Solid	62100
SS1-260406-1305	Arthur Kill	SS1	4/26/06	Solid	72000
SS2-260406-1310	Arthur Kill	SS2	4/26/06	Solid	215000

10/29/09

Table 13 TOC - Solids.xls

TABLE 13

**TOTAL ORGANIC CARBON SOLID SAMPLE DATA SUMMARY
 DEMONSTRATION TESTING AND FULL-SCALE OPERATION OF THE
 BIOGENESIS SEDIMENT DECONTAMINATION PROCESS
 KEASBEY, NEW JERSEY**

(Page 10 of 13)

Field Sample Identification	Sediment Source	Location Identification	Date Collected	Matrix	TOC (mg/kg)
RS-260406-1315	Arthur Kill	RS	4/26/06	Solid	247000
TS-260406-1335	Arthur Kill	TS	4/26/06	Solid	29200
TS1-260406-1320	Arthur Kill	TS1	4/26/06	Solid	110000
TS2-260406-1325	Arthur Kill	TS2	4/26/06	Solid	21400
TS3-260406-1330	Arthur Kill	TS3	4/26/06	Solid	31400
WS-260406-1340	Arthur Kill	WS	4/26/06	Solid	101000
PSS-270406-1700	Arthur Kill	PSS	4/27/06	Solid	72900
SS1-270406-1705	Arthur Kill	SS1	4/27/06	Solid	240000
SS2-270406-1710	Arthur Kill	SS2	4/27/06	Solid	68000
RS-270406-1715	Arthur Kill	RS	4/27/06	Solid	155000
TS-270406-1735	Arthur Kill	TS	4/27/06	Solid	29000
TS1-270406-1720	Arthur Kill	TS1	4/27/06	Solid	52900
TS2-270406-1725	Arthur Kill	TS2	4/27/06	Solid	25200
TS3-270406-1730	Arthur Kill	TS3	4/27/06	Solid	32400
WS-270406-1740	Arthur Kill	WS	4/27/06	Solid	81800
PSS-280406-1100	Arthur Kill	PSS	4/28/06	Solid	44800
PSS-280406-1100	Arthur Kill	PSS	4/28/06	Solid	47400
SS1-280406-1105	Arthur Kill	SS1	4/28/06	Solid	87700
SS2-280406-1110	Arthur Kill	SS2	4/28/06	Solid	52600
RS-280406-1115	Arthur Kill	RS	4/28/06	Solid	45200
TS-280406-1135	Arthur Kill	TS	4/28/06	Solid	27600
TSGRAB-280406-0815	Arthur Kill	TS	4/28/06	Solid	20300
TSGRAB-280406-1115	Arthur Kill	TS	4/28/06	Solid	24300
TSGRAB-280406-1115	Arthur Kill	TS	4/28/06	Solid	20200
TS1-280406-1120	Arthur Kill	TS1	4/28/06	Solid	23400
TS1GRAB-280406-0800	Arthur Kill	TS1	4/28/06	Solid	55600
TS1GRAB-280406-1100	Arthur Kill	TS1	4/28/06	Solid	32200
TS2-280406-1125	Arthur Kill	TS2	4/28/06	Solid	10600
TS2GRAB-280406-0805	Arthur Kill	TS2	4/28/06	Solid	14800
TS2GRAB-280406-1105	Arthur Kill	TS2	4/28/06	Solid	28400
TS3-280406-1130	Arthur Kill	TS3	4/28/06	Solid	28400
TS3GRAB-280406-0810	Arthur Kill	TS3	4/28/06	Solid	29000
TS3GRAB-280406-1110	Arthur Kill	TS3	4/28/06	Solid	28900

TABLE 13

**TOTAL ORGANIC CARBON SOLID SAMPLE DATA SUMMARY
 DEMONSTRATION TESTING AND FULL-SCALE OPERATION OF THE
 BIOGENESIS SEDIMENT DECONTAMINATION PROCESS
 KEASBEY, NEW JERSEY
 (Page 11 of 13)**

Field Sample Identification	Sediment Source	Location Identification	Date Collected	Matrix	TOC (mg/kg)
WS-280406-1140	Arthur Kill	WS	4/28/06	Solid	79700
PSS-010506-1600	Lower Passaic River	PSS	5/1/06	Solid	74100 J
PSS-010506-1600	Lower Passaic River	PSS	5/1/06	Solid	111000
SS1-010506-1605	Lower Passaic River	SS1	5/1/06	Solid	283000 J
SS2-010506-1610	Lower Passaic River	SS2	5/1/06	Solid	346000 J
RS-010506-1615	Lower Passaic River	RS	5/1/06	Solid	56500 J
TS-010506-1635	Lower Passaic River	TS	5/1/06	Solid	43900 J
TS1-010506-1620	Lower Passaic River	TS1	5/1/06	Solid	71700 J
TS2-010506-1625	Lower Passaic River	TS2	5/1/06	Solid	31500 J
TS3-010506-1630	Lower Passaic River	TS3	5/1/06	Solid	42800 J
WS-010506-1640	Lower Passaic River	WS	5/1/06	Solid	100000 J
PSS-020506-1600	Lower Passaic River	PSS	5/2/06	Solid	57600
SS1-020506-1605	Lower Passaic River	SS1	5/2/06	Solid	282000
SS2-020506-1610	Lower Passaic River	SS2	5/2/06	Solid	337000
RS-020506-1615	Lower Passaic River	RS	5/2/06	Solid	78600
TS-020506-1635	Lower Passaic River	TS	5/2/06	Solid	51700
STS-1-020506-1200	Lower Passaic River	TS	5/2/06	Solid	44800
STS-2-020506-1500	Lower Passaic River	TS	5/2/06	Solid	47900
STS-2-020506-1500	Lower Passaic River	TS	5/2/06	Solid	46200
TS1-020506-1620	Lower Passaic River	TS1	5/2/06	Solid	211000
TS2-020506-1625	Lower Passaic River	TS2	5/2/06	Solid	30900
TS3-020506-1630	Lower Passaic River	TS3	5/2/06	Solid	49100
WS-020506-1640	Lower Passaic River	WS	5/2/06	Solid	123000
PSS-030506-1600	Lower Passaic River	PSS	5/3/06	Solid	55400
PSS-030506-1600	Lower Passaic River	PSS	5/3/06	Solid	56700
SS1-030506-1605	Lower Passaic River	SS1	5/3/06	Solid	291000
SS2-030506-1610	Lower Passaic River	SS2	5/3/06	Solid	305000
RS-030506-1615	Lower Passaic River	RS	5/3/06	Solid	56700
TS-030506-1635	Lower Passaic River	TS	5/3/06	Solid	45900
STS-3-030506-1200	Lower Passaic River	TS	5/3/06	Solid	47100
STS-4-030506-1400	Lower Passaic River	TS	5/3/06	Solid	41200
TS1-030506-1620	Lower Passaic River	TS1	5/3/06	Solid	181000
TS2-030506-1625	Lower Passaic River	TS2	5/3/06	Solid	19200

TABLE 13

**TOTAL ORGANIC CARBON SOLID SAMPLE DATA SUMMARY
 DEMONSTRATION TESTING AND FULL-SCALE OPERATION OF THE
 BIOGENESIS SEDIMENT DECONTAMINATION PROCESS
 KEASBEY, NEW JERSEY
 (Page 12 of 13)**

Field Sample Identification	Sediment Source	Location Identification	Date Collected	Matrix	TOC (mg/kg)
TS3-030506-1630	Lower Passaic River	TS3	5/3/06	Solid	42000
WS-030506-1640	Lower Passaic River	WS	5/3/06	Solid	130000
PSS-040506-1600	Lower Passaic River	PSS	5/4/06	Solid	48400
PSS-040506-1600B	Lower Passaic River	PSS	5/4/06	Solid	58700
SS1-040506-1605	Lower Passaic River	SS1	5/4/06	Solid	187000
SS1-040506-1605B	Lower Passaic River	SS1	5/4/06	Solid	102000
SS2-040506-1610	Lower Passaic River	SS2	5/4/06	Solid	71300
SS2-040506-1610B	Lower Passaic River	SS2	5/4/06	Solid	113000
RS-040506-1615	Lower Passaic River	RS	5/4/06	Solid	55000
RS-040506-1615B	Lower Passaic River	RS	5/4/06	Solid	53900
STS-5-040506-1200	Lower Passaic River	TS	5/4/06	Solid	40400
STS-6-040506-1500	Lower Passaic River	TS	5/4/06	Solid	38200
STS-6-040506-1500	Lower Passaic River	TS	5/4/06	Solid	39300
TS-040506-1635	Lower Passaic River	TS	5/4/06	Solid	44900
TS-040506-1635B	Lower Passaic River	TS	5/4/06	Solid	47800
TS1-040506-1620	Lower Passaic River	TS1	5/4/06	Solid	292000
TS1-040506-1620B	Lower Passaic River	TS1	5/4/06	Solid	332000
TS2-040506-1625	Lower Passaic River	TS2	5/4/06	Solid	11900
TS2-040506-1625B	Lower Passaic River	TS2	5/4/06	Solid	15000
TS3-040506-1630	Lower Passaic River	TS3	5/4/06	Solid	46800
TS3-040506-1630B	Lower Passaic River	TS3	5/4/06	Solid	48600
WS-040506-1640	Lower Passaic River	WS	5/4/06	Solid	122000
WS-040506-1640B	Lower Passaic River	WS	5/4/06	Solid	109000
MSL01-040107-0905	Lower Passaic River	MSL	1/4/07	Solid	22200
MSL02-040107-0925	Lower Passaic River	MSL	1/4/07	Solid	22400
MSL03-040107-0940	Lower Passaic River	MSL	1/4/07	Solid	25900
MSL04-040107-0950	Lower Passaic River	MSL	1/4/07	Solid	36000
MSL05-040107-1	Lower Passaic River	MSL	1/4/07	Solid	27200
MSL05-040107-1000	Lower Passaic River	MSL	1/4/07	Solid	22600
MSL06-040107-1015	Lower Passaic River	MSL	1/4/07	Solid	25800
MSL07-040107-1025	Lower Passaic River	MSL	1/4/07	Solid	20100
MSL08-040107-1035	Lower Passaic River	MSL	1/4/07	Solid	21800
MSL09-040107-1045	Lower Passaic River	MSL	1/4/07	Solid	23500

TABLE 13

**TOTAL ORGANIC CARBON SOLID SAMPLE DATA SUMMARY
 DEMONSTRATION TESTING AND FULL-SCALE OPERATION OF THE
 BIOGENESIS SEDIMENT DECONTAMINATION PROCESS
 KEASBEY, NEW JERSEY
 (Page 13 of 13)**

Field Sample Identification	Sediment Source	Location Identification	Date Collected	Matrix	TOC (mg/kg)
MSL10-040107-1055	Lower Passaic River	MSL	1/4/07	Solid	19900
MSL11-040107-1055	Lower Passaic River	MSL	1/4/07	Solid	19000
TS1-121908-0800	Lower Passaic River	TS	12/19/08	Solid	25400
AD1-121908-0830	None	AD	12/19/08	Solid	51900
AD2-121908-0820	None	AD	12/19/08	Solid	237 T
AD3-121808-0840	None	AD	12/19/08	Solid	420000
MS1-121908-0850	Lower Passaic River	MSL	12/19/08	Solid	152000

mg/kg milligrams per kilogram.

Bold Bolded result indicates positively identified compound.

B Analyte detected in an associated blank.

H Sample holding time was exceeded, but the associated data are considered valid as reported.

J Data are estimated due to associated quality control data.

T Analyte was positively identified but the reported concentration is estimated; reported concentration is less than the reporting limit, but greater than the method detection limit.

TOC Total organic carbon

TABLE 14

**OIL AND GREASE SOLID SAMPLE DATA SUMMARY
 DEMONSTRATION TESTING AND FULL-SCALE OPERATION OF THE
 BIOGENESIS SEDIMENT DECONTAMINATION PROCESS
 KEASBEY, NEW JERSEY**

(Page 1 of 4)

Field Sample Identification	Sediment Source	Location Identification	Date Collected	Matrix	Oil/Grease (mg/kg)
PSS-240406-1600	Arthur Kill	PSS	4/24/06	Solid	2970
SS1-240406-1605	Arthur Kill	SS1	4/24/06	Solid	3790
SS2-240406-1610	Arthur Kill	SS2	4/24/06	Solid	2880
RS-240406-1615	Arthur Kill	RS	4/24/06	Solid	2050
INF1-250406-1845	Arthur Kill	RS	4/24/06	Solid	2460
INF1-260406-1345	Arthur Kill	RS	4/24/06	Solid	1830
TS-240406-1635	Arthur Kill	TS	4/24/06	Solid	2200
TS1-240406-1620	Arthur Kill	TS1	4/24/06	Solid	1730
TS2-240406-1625	Arthur Kill	TS2	4/24/06	Solid	612
TS3-240406-1630	Arthur Kill	TS3	4/24/06	Solid	2120
WS-240406-1640	Arthur Kill	WS	4/24/06	Solid	7880
PSS-250406-1800	Arthur Kill	PSS	4/25/06	Solid	3200
SS2-250406-1810	Arthur Kill	SS2	4/25/06	Solid	2880
RS-250406-1815	Arthur Kill	RS	4/25/06	Solid	3920
TS-250406-1835	Arthur Kill	TS	4/25/06	Solid	2410
TS1-250406-1820	Arthur Kill	TS1	4/25/06	Solid	2060
TS2-250406-1825	Arthur Kill	TS2	4/25/06	Solid	842
TS3-250406-1830	Arthur Kill	TS3	4/25/06	Solid	2890
WS-250406-1840	Arthur Kill	WS	4/25/06	Solid	10900
PSS-260406-1300	Arthur Kill	PSS	4/26/06	Solid	2640
SS1-260406-1305	Arthur Kill	SS1	4/26/06	Solid	1830
SS2-260406-1310	Arthur Kill	SS2	4/26/06	Solid	1880
RS-260406-1315	Arthur Kill	RS	4/26/06	Solid	2900
TS-260406-1335	Arthur Kill	TS	4/26/06	Solid	2260
TS1-260406-1320	Arthur Kill	TS1	4/26/06	Solid	1210
TS2-260406-1325	Arthur Kill	TS2	4/26/06	Solid	718
TS3-260406-1330	Arthur Kill	TS3	4/26/06	Solid	2660
WS-260406-1340	Arthur Kill	WS	4/26/06	Solid	10600
PSS-270406-1700	Arthur Kill	PSS	4/27/06	Solid	1680
SS1-270406-1705	Arthur Kill	SS1	4/27/06	Solid	2490
SS2-270406-1710	Arthur Kill	SS2	4/27/06	Solid	3210
RS-270406-1715	Arthur Kill	RS	4/27/06	Solid	1350
TS-270406-1735	Arthur Kill	TS	4/27/06	Solid	2020
TS1-270406-1720	Arthur Kill	TS1	4/27/06	Solid	1990
TS2-270406-1725	Arthur Kill	TS2	4/27/06	Solid	335
TS3-270406-1730	Arthur Kill	TS3	4/27/06	Solid	2040

10/29/09

Table 14 Oil and Grease - Solids.xls

TABLE 14

**OIL AND GREASE SOLID SAMPLE DATA SUMMARY
 DEMONSTRATION TESTING AND FULL-SCALE OPERATION OF THE
 BIOGENESIS SEDIMENT DECONTAMINATION PROCESS
 KEASBEY, NEW JERSEY**

(Page 2 of 4)

Field Sample Identification	Sediment Source	Location Identification	Date Collected	Matrix	Oil/Grease (mg/kg)
WS-270406-1740	Arthur Kill	WS	4/27/06	Solid	9110
PSS-280406-1100	Arthur Kill	PSS	4/28/06	Solid	2910
SS1-280406-1105	Arthur Kill	SS1	4/28/06	Solid	1780
SS2-280406-1110	Arthur Kill	SS2	4/28/06	Solid	2510
RS-280406-1115	Arthur Kill	RS	4/28/06	Solid	2260
TS-280406-1135	Arthur Kill	TS	4/28/06	Solid	1500
TSGRAB-280406-0815	Arthur Kill	TS	4/28/06	Solid	2200
TSGRAB-280406-1115	Arthur Kill	TS	4/28/06	Solid	2300
TS1-280406-1120	Arthur Kill	TS1	4/28/06	Solid	1660
TS1GRAB-280406-0800	Arthur Kill	TS1	4/28/06	Solid	1610
TS1GRAB-280406-1100	Arthur Kill	TS1	4/28/06	Solid	1350
TS2-280406-1125	Arthur Kill	TS2	4/28/06	Solid	736
TS2GRAB-280406-0805	Arthur Kill	TS2	4/28/06	Solid	802
TS2GRAB-280406-1105	Arthur Kill	TS2	4/28/06	Solid	835
TS3-280406-1130	Arthur Kill	TS3	4/28/06	Solid	2020
TS3GRAB-280406-0810	Arthur Kill	TS3	4/28/06	Solid	1890
TS3GRAB-280406-1110	Arthur Kill	TS3	4/28/06	Solid	1940
WS-280406-1140	Arthur Kill	WS	4/28/06	Solid	9480
PSS-010506-1600	Lower Passaic River	PSS	5/1/06	Solid	2720
SS1-010506-1605	Lower Passaic River	SS1	5/1/06	Solid	7420
SS2-010506-1610	Lower Passaic River	SS2	5/1/06	Solid	6880
RS-010506-1615	Lower Passaic River	RS	5/1/06	Solid	2560
TS-010506-1635	Lower Passaic River	TS	5/1/06	Solid	2560
TS1-010506-1620	Lower Passaic River	TS1	5/1/06	Solid	2650
TS2-010506-1625	Lower Passaic River	TS2	5/1/06	Solid	1900
TS3-010506-1630	Lower Passaic River	TS3	5/1/06	Solid	2070
WS-010506-1640	Lower Passaic River	WS	5/1/06	Solid	3180
PSS-020506-1600	Lower Passaic River	PSS	5/2/06	Solid	3940
SS1-020506-1605	Lower Passaic River	SS1	5/2/06	Solid	6250
SS2-020506-1610	Lower Passaic River	SS2	5/2/06	Solid	9530
RS-020506-1615	Lower Passaic River	RS	5/2/06	Solid	1330
TS-020506-1635	Lower Passaic River	TS	5/2/06	Solid	1900
STS-1-020506-1200	Lower Passaic River	TS	5/2/06	Solid	2520
STS-2-020506-1500	Lower Passaic River	TS	5/2/06	Solid	2690
TS1-020506-1620	Lower Passaic River	TS1	5/2/06	Solid	6720
TS2-020506-1625	Lower Passaic River	TS2	5/2/06	Solid	1940

10/29/09

Table 14 Oil and Grease - Solids.xls

TABLE 14

**OIL AND GREASE SOLID SAMPLE DATA SUMMARY
 DEMONSTRATION TESTING AND FULL-SCALE OPERATION OF THE
 BIOGENESIS SEDIMENT DECONTAMINATION PROCESS
 KEASBEY, NEW JERSEY
 (Page 3 of 4)**

Field Sample Identification	Sediment Source	Location Identification	Date Collected	Matrix	Oil/Grease (mg/kg)
TS3-020506-1630	Lower Passaic River	TS3	5/2/06	Solid	2060
WS-020506-1640	Lower Passaic River	WS	5/2/06	Solid	6770
PSS-030506-1600	Lower Passaic River	PSS	5/3/06	Solid	3700
SS1-030506-1605	Lower Passaic River	SS1	5/3/06	Solid	5640
SS2-030506-1610	Lower Passaic River	SS2	5/3/06	Solid	5860
RS-030506-1615	Lower Passaic River	RS	5/3/06	Solid	3670
TS-030506-1635	Lower Passaic River	TS	5/3/06	Solid	1300
STS-3-030506-1200	Lower Passaic River	TS	5/3/06	Solid	1110
STS-4-030506-1400	Lower Passaic River	TS	5/3/06	Solid	1350
TS1-030506-1620	Lower Passaic River	TS1	5/3/06	Solid	6510
TS2-030506-1625	Lower Passaic River	TS2	5/3/06	Solid	1540
TS3-030506-1630	Lower Passaic River	TS3	5/3/06	Solid	1270
WS-030506-1640	Lower Passaic River	WS	5/3/06	Solid	1900
PSS-040506-1600	Lower Passaic River	PSS	5/4/06	Solid	4310
PSS-040506-1600B	Lower Passaic River	PSS	5/4/06	Solid	8400 J
SS1-040506-1605	Lower Passaic River	SS1	5/4/06	Solid	5970
SS1-040506-1605B	Lower Passaic River	SS1	5/4/06	Solid	15000 J
SS2-040506-1610	Lower Passaic River	SS2	5/4/06	Solid	4450
SS2-040506-1610B	Lower Passaic River	SS2	5/4/06	Solid	7700 J
RS-040506-1615	Lower Passaic River	RS	5/4/06	Solid	3480
RS-040506-1615B	Lower Passaic River	RS	5/4/06	Solid	4700 J
STS-5-040506-1200	Lower Passaic River	TS	5/4/06	Solid	2550
STS-6-040506-1500	Lower Passaic River	TS	5/4/06	Solid	2480
TS-040506-1635	Lower Passaic River	TS	5/4/06	Solid	1320
TS-040506-1635B	Lower Passaic River	TS	5/4/06	Solid	3000 J
TS1-040506-1620	Lower Passaic River	TS1	5/4/06	Solid	8840
TS1-040506-1620B	Lower Passaic River	TS1	5/4/06	Solid	33000 J
TS2-040506-1625	Lower Passaic River	TS2	5/4/06	Solid	1100
TS2-040506-1625B	Lower Passaic River	TS2	5/4/06	Solid	3200 J
TS3-040506-1630	Lower Passaic River	TS3	5/4/06	Solid	1210
TS3-040506-1630B	Lower Passaic River	TS3	5/4/06	Solid	3600 J
WS-040506-1640	Lower Passaic River	WS	5/4/06	Solid	2770
WS-040506-1640B	Lower Passaic River	WS	5/4/06	Solid	4600 J
SPC COMP-160506-1700	All	TSP	5/16/06	Solid	2240
SPP COMP-170506-1030	All	TSP	5/17/06	Solid	1980
MSL01-040107-0905	Lower Passaic River	MSL	1/4/07	Solid	767

10/29/09

Table 14 Oil and Grease - Solids.xls

TABLE 14

**OIL AND GREASE SOLID SAMPLE DATA SUMMARY
 DEMONSTRATION TESTING AND FULL-SCALE OPERATION OF THE
 BIOGENESIS SEDIMENT DECONTAMINATION PROCESS
 KEASBEY, NEW JERSEY
 (Page 4 of 4)**

Field Sample Identification	Sediment Source	Location Identification	Date Collected	Matrix	Oil/Grease (mg/kg)
MSL02-040107-0925	Lower Passaic River	MSL	1/4/07	Solid	619
MSL03-040107-0940	Lower Passaic River	MSL	1/4/07	Solid	672
MSL04-040107-0950	Lower Passaic River	MSL	1/4/07	Solid	598
MSL05-040107-1000	Lower Passaic River	MSL	1/4/07	Solid	599
MSL06-040107-1015	Lower Passaic River	MSL	1/4/07	Solid	380
MSL07-040107-1025	Lower Passaic River	MSL	1/4/07	Solid	407
MSL08-040107-1035	Lower Passaic River	MSL	1/4/07	Solid	275
MSL09-040107-1045	Lower Passaic River	MSL	1/4/07	Solid	414
MSL10-040107-1055	Lower Passaic River	MSL	1/4/07	Solid	354
MSL11-040107-1055	Lower Passaic River	MSL	1/4/07	Solid	352
TS1-121908-0800	Lower Passaic River	TS	12/19/08	Solid	505
AD1-121908-0830	None	AD	12/19/08	Solid	<175
AD2-121908-0820	None	AD	12/19/08	Solid	<172
AD3-121908-0840	None	AD	12/19/08	Solid	1490 D
MS1-121908-0850	Lower Passaic River	MSL	12/19/08	Solid	451

mg/kg milligrams per kilogram.

Bold Bolded result indicates positively identified compound.

J Data are estimated due to associated quality control data.

D Sample dilution required for analysis; reported values reflect the dilution.

TABLE 15

**PERCENT MOISURE/SOLIDS SAMPLE DATA SUMMARY
 DEMONSTRATION TESTING AND FULL-SCALE OPERATION OF THE
 BIOGENESIS SEDIMENT DECONTAMINATION PROCESS
 KEASBEY, NEW JERSEY**

(Page 1 of 16)

Field Sample Identification	Sediment Source	Location Identification	Date Collected	Matrix	Moisture, Percent	Solids, Percent
BAY-1	Raritan River	PPS	11/23/05	Solid	-	50.5
RS-211205-1000	Raritan River	RS	12/21/05	Solid	-	36.4
TS-211205-1715	Raritan River	TS	12/21/05	Solid	-	72.7
TS-211205-1715	Raritan River	TS	12/21/05	Solid	-	73.5
WS1-211205-1800	Raritan River	WS	12/21/05	Solid	-	31.1
TS-291205-1100	Raritan River	TS	12/29/05	Solid	-	68.8
WS-291205-1110	Raritan River	WS	12/29/05	Solid	-	31.4
WS-291205-1110	Raritan River	WS	12/29/05	Solid	-	31.4
RS-030106-1600	Raritan River	RS	1/3/06	Solid	-	37
RS-030106-1600	Raritan River	RS	1/3/06	Solid	-	36.6
TS-030106-1645	Raritan River	TS	1/3/06	Solid	-	71.8
WS1-030106-1615	Raritan River	WS1	1/3/06	Solid	-	26.9
WS2-030106-1630	Raritan River	WS2	1/3/06	Solid	-	34.7
RS-040106-1300	Raritan River	RS	1/4/06	Solid	-	26.8
TS-040106-1100	Raritan River	TS	1/4/06	Solid	-	68.1
WS-040106-1400	Raritan River	WS	1/4/06	Solid	-	31.1
RS-050106-1500	Raritan River	RS	1/5/06	Solid	-	32.5
TS-050106-1505	Raritan River	TS	1/5/06	Solid	-	66.5
WS-050106-1510	Raritan River	WS	1/5/06	Solid	-	35.8
RS-060106-1531	Raritan River	RS	1/6/06	Solid	-	8.2
TS-060106-1532	Raritan River	TS	1/6/06	Solid	-	63.5
WS-060106-1533	Raritan River	WS	1/6/06	Solid	-	35.5
RS-090106-1500	Raritan River	RS	1/9/06	Solid	-	25.5
TS-090106-1501	Raritan River	TS	1/9/06	Solid	-	65.8
WS-090106-1502	Raritan River	WS	1/9/06	Solid	-	37.2
RS-100106-1600	Raritan River	RS	1/10/06	Solid	-	19.7
TS-100106-1601	Raritan River	TS	1/10/06	Solid	-	53.8
WS-100106-1602	Raritan River	WS	1/10/06	Solid	-	40.4
RS-110106-1630	Raritan River	RS	1/11/06	Solid	65	35.4
TS-110106-1631	Raritan River	TS	1/11/06	Solid	51.1	48.1
RS-120106-1630	Raritan River	RS	1/12/06	Solid	-	27.8

10/29/09

Table 15 Percent Moist - Solids.xls

TABLE 15

**PERCENT MOISURE/SOLIDS SAMPLE DATA SUMMARY
 DEMONSTRATION TESTING AND FULL-SCALE OPERATION OF THE
 BIOGENESIS SEDIMENT DECONTAMINATION PROCESS
 KEASBEY, NEW JERSEY**

(Page 2 of 16)

Field Sample Identification	Sediment Source	Location Identification	Date Collected	Matrix	Moisture, Percent	Solids, Percent
TS-120106-1601	Raritan River	TS	1/12/06	Solid	-	59.3
WS-120106-1602	Raritan River	WS	1/12/06	Solid	-	32.1
RS-190106-1600	Lower Passaic River	RS	1/19/06	Solid	-	18.7
TS-190106-1601	Lower Passaic River	TS	1/19/06	Solid	-	53.3
WS-190106-1602	Lower Passaic River	WS	1/19/06	Solid	-	26.2
RS-240106-1530	Lower Passaic River	RS	1/24/06	Solid	-	21.2
RS-240106-1530	Lower Passaic River	RS	1/24/06	Solid	-	21.2
TS-240106-1630	Lower Passaic River	TS	1/24/06	Solid	-	62.9
RS-270106-1400	Lower Passaic River	RS	1/27/06	Solid	-	31.7
RS-270106-1400	Lower Passaic River	RS	1/27/06	Solid	-	31.7
TS-270106-1401	Lower Passaic River	TS	1/27/06	Solid	-	65.7
TS-270106-1530	Lower Passaic River	TS	1/27/06	Solid	-	60.5
WS-270106-1402	Lower Passaic River	WS	1/27/06	Solid	-	27.9
WS-270106-1531	Lower Passaic River	WS	1/27/06	Solid	-	26
RS-300106-1700	Raritan River	RS	1/30/06	Solid	-	18.6
WS2-300106-1702	Raritan River	WS2	1/30/06	Solid	-	51.7
RS-310106-1700	Raritan River	RS	1/31/06	Solid	-	8.6
TS-310106-1701	Raritan River	TS	1/31/06	Solid	-	61.1
WS-310106-1702	Raritan River	WS	1/31/06	Solid	-	30.1
RS-010206-1600	Raritan River	RS	2/1/06	Solid	-	21
TS-010206-1601	Raritan River	TS	2/1/06	Solid	-	65.1
WS-010206-1602	Raritan River	WS	2/1/06	Solid	-	35.4
RS-020206-1800	Raritan River	RS	2/2/06	Solid	-	15.7
TS-020206-1801	Raritan River	TS	2/2/06	Solid	-	62.2
WS-020206-1802	Raritan River	WS	2/2/06	Solid	-	32
RS-030206-1200	Raritan River	RS	2/3/06	Solid	-	36.1
RS-030206-1200	Raritan River	RS	2/3/06	Solid	-	36.3
TS-030206-1201	Raritan River	TS	2/3/06	Solid	-	62.1
WS-030206-1202	Raritan River	WS	2/3/06	Solid	-	27.8
RS-060206-1930	Raritan River	RS	2/6/06	Solid	-	32.4
RS-060206-1930	Raritan River	RS	2/6/06	Solid	-	28.1

10/29/09

Table 15 Percent Moist - Solids.xls

TABLE 15

**PERCENT MOISURE/SOLIDS SAMPLE DATA SUMMARY
 DEMONSTRATION TESTING AND FULL-SCALE OPERATION OF THE
 BIOGENESIS SEDIMENT DECONTAMINATION PROCESS
 KEASBEY, NEW JERSEY**

(Page 3 of 16)

Field Sample Identification	Sediment Source	Location Identification	Date Collected	Matrix	Moisture, Percent	Solids, Percent
TS-060206-1931	Raritan River	TS	2/6/06	Solid	-	65.1
WS-060206-1932	Raritan River	WS	2/6/06	Solid	-	29.1
SP-070206-1445	Raritan River	PPS	2/7/06	Solid	-	42.1
RS-070206-1630	Raritan River	RS	2/7/06	Solid	-	31.6
TS-070206-1631	Raritan River	TS	2/7/06	Solid	-	63.5
TS-070206-1631 DRIED	Raritan River	TS	2/7/06	Solid	-	77.1
WS-070206-1632	Raritan River	WS	2/7/06	Solid	-	29.3
RS-080206-1700	Raritan River	RS	2/8/06	Solid	-	33.9
TS-080206-1701	Raritan River	TS	2/8/06	Solid	-	64.3
WS-080206-1702	Raritan River	WS	2/8/06	Solid	-	28.6
RS-090206-2300	Arthur Kill	RS	2/9/06	Solid	-	32.7
TS-090206-2301	Arthur Kill	TS	2/9/06	Solid	-	65
WS-090206-2302	Arthur Kill	WS	2/9/06	Solid	-	30.5
RS-130206-1700	Lower Passaic River	RS	2/13/06	Solid	-	24.2
TS-130206-1701	Lower Passaic River	TS	2/13/06	Solid	-	76.4
WS-130206-1702	Lower Passaic River	WS	2/13/06	Solid	-	24.2
RS-140206-1330	Arthur Kill	RS	2/14/06	Solid	-	25.9
TS-140206-1331	Arthur Kill	TS	2/14/06	Solid	-	74.6
WS-140206-1332	Arthur Kill	WS	2/14/06	Solid	-	27.5
RS-160206-1500	Arthur Kill	RS	2/16/06	Solid	-	32.7
TS-160206-1501	Arthur Kill	TS	2/16/06	Solid	-	67.1
WS-160206-1502	Arthur Kill	WS	2/16/06	Solid	-	29.1
RS-170206-1100	Arthur Kill	RS	2/17/06	Solid	-	23
TS-170206-1101	Arthur Kill	TS	2/17/06	Solid	-	71.8
WS-170206-1102	Arthur Kill	WS	2/17/06	Solid	-	24.5
TS-230206-0930	Arthur Kill	TS	2/23/06	Solid	-	70.5
TS-230206-0930 DRIED	Arthur Kill	TS	2/23/06	Solid	-	69
RS-270206-1400	Lower Passaic River	RS	2/27/06	Solid	-	30.6
TS-270206-1350	Lower Passaic River	TS	2/27/06	Solid	-	67.1
TS-270206-1350	Lower Passaic River	TS	2/27/06	Solid	-	66.6
TS-270206-1350 DRIED	Lower Passaic River	TS	2/27/06	Solid	-	70.5

10/29/09

Table 15 Percent Moist - Solids.xls

TABLE 15

**PERCENT MOISURE/SOLIDS SAMPLE DATA SUMMARY
 DEMONSTRATION TESTING AND FULL-SCALE OPERATION OF THE
 BIOGENESIS SEDIMENT DECONTAMINATION PROCESS
 KEASBEY, NEW JERSEY**

(Page 4 of 16)

Field Sample Identification	Sediment Source	Location Identification	Date Collected	Matrix	Moisture, Percent	Solids, Percent
TS-270206-1630	Lower Passaic River	TS	2/27/06	Solid	-	70.1
TS-270206-1630 DRIED	Lower Passaic River	TS	2/27/06	Solid	-	73.2
RS-280206-1700	Arthur Kill	RS	2/28/06	Solid	-	30.4
TS-280206-1705	Arthur Kill	TS	2/28/06	Solid	-	66.7
WS-280206-1710	Arthur Kill	WS	2/28/06	Solid	-	25.2
RS-010306-1700	Arthur Kill	RS	3/1/06	Solid	-	25.6
TS-010306-1705	Arthur Kill	TS	3/1/06	Solid	-	63.3
WS-010306-1710	Arthur Kill	WS	3/1/06	Solid	-	27
SS-020306-1400	Arthur Kill	SS1	3/2/06	Solid	-	47.6
RS-020306-1700	Arthur Kill	RS	3/2/06	Solid	-	23.9
TS-020306-1705	Arthur Kill	TS	3/2/06	Solid	-	59.3
WS-020306-1710	Arthur Kill	WS	3/2/06	Solid	-	26.4
RS-030306-1200	Arthur Kill	RS	3/3/06	Solid	-	21
TS-030306-1205	Arthur Kill	TS	3/3/06	Solid	-	58.1
WS-030306-1210	Arthur Kill	WS	3/3/06	Solid	-	28.1
SEC SCREEN-INFLUENT	Lower Passaic River	PSS	3/16/06	Solid	-	29.2
SEC SCREEN-INFLUENT	Lower Passaic River	PSS	3/16/06	Solid	-	28.8
SEC SCREEN-SCREENINGS	Lower Passaic River	SS1	3/16/06	Solid	-	30.2
SEC SCREEN-EFFLUENT	Lower Passaic River	RS	3/16/06	Solid	-	28.6
SCALPING SCREEN	Lower Passaic River	TS1	3/16/06	Solid	-	29.3
HYDROCYCLONES	Lower Passaic River	TS2	3/16/06	Solid	-	69.2
HYDROCYCLONE OVERFLOW	Lower Passaic River	HO	3/16/06	Solid	-	25.7
PSS-210306-0915	Arthur Kill	PSS	3/21/06	Solid	-	27.1
PSS-210306-0915-AD	Arthur Kill	PSS	3/21/06	Solid	-	24.7
PSS-210306-0915-RR	Arthur Kill	PSS	3/21/06	Solid	-	24.7
PSS-210306-0915-RR	Arthur Kill	PSS	3/21/06	Solid	-	24.2
PSS-210306-0915-RR1	Arthur Kill	PSS	3/21/06	Solid	-	24.4
SS1-210306-0920	Arthur Kill	SS1	3/21/06	Solid	-	55.6
SS1-210306-0920-RR	Arthur Kill	SS1	3/21/06	Solid	-	49.9
SS2-210306-0925	Arthur Kill	SS2	3/21/06	Solid	-	39
SS2-210306-0925-RR	Arthur Kill	SS2	3/21/06	Solid	-	56

10/29/09

Table 15 Percent Moist - Solids.xls

TABLE 15

**PERCENT MOISURE/SOLIDS SAMPLE DATA SUMMARY
 DEMONSTRATION TESTING AND FULL-SCALE OPERATION OF THE
 BIOGENESIS SEDIMENT DECONTAMINATION PROCESS
 KEASBEY, NEW JERSEY**

(Page 5 of 16)

Field Sample Identification	Sediment Source	Location Identification	Date Collected	Matrix	Moisture, Percent	Solids, Percent
RS-210306-0930	Arthur Kill	RS	3/21/06	Solid	-	25.1
RS-210306-0930-AD	Arthur Kill	RS	3/21/06	Solid	-	22.2
RS-210306-0930-RR	Arthur Kill	RS	3/21/06	Solid	-	22.2
RS-210306-0930-RR1	Arthur Kill	RS	3/21/06	Solid	-	22.4
RS-210306-0930-RR2	Arthur Kill	RS	3/21/06	Solid	-	25.1
RS-210306-0930-RR2-DUP	Arthur Kill	RS	3/21/06	Solid	-	25.1
RS-210306-0930-RR2-SE	Arthur Kill	RS	3/21/06	Solid	-	25.1
RS-210306-0930-RR2-SE-DUP	Arthur Kill	RS	3/21/06	Solid	-	25.1
TS-210306-1030	Arthur Kill	TS	3/21/06	Solid	-	66.4
TS-210306-1030-RR	Arthur Kill	TS	3/21/06	Solid	-	71.2
TS4-210306-1130	Arthur Kill	TS	3/21/06	Solid	-	68
TS1-210306-1035	Arthur Kill	TS1	3/21/06	Solid	-	77.5
TS1-210306-1035-RR	Arthur Kill	TS1	3/21/06	Solid	-	78.4
TS5-210306-1135	Arthur Kill	TS1	3/21/06	Solid	-	81.2
TS2-210306-1040	Arthur Kill	TS2	3/21/06	Solid	-	70.7
TS2-210306-1040-RR	Arthur Kill	TS2	3/21/06	Solid	-	73
TS6-210306-1140	Arthur Kill	TS2	3/21/06	Solid	-	78.8
TS3-210306-1045	Arthur Kill	TS3	3/21/06	Solid	-	60.9
TS7-210306-1145	Arthur Kill	TS3	3/21/06	Solid	-	62.1
TS-220306-1000	Arthur Kill	TS	3/22/06	Solid	-	68.8
TS-220306-1000	Arthur Kill	TS	3/22/06	Solid	-	69.7
TS1-220306-1005	Arthur Kill	TS1	3/22/06	Solid	-	71.5
TS2-220306-1010	Arthur Kill	TS2	3/22/06	Solid	-	72.5
TS3-220306-1015	Arthur Kill	TS3	3/22/06	Solid	-	62.6
PSS-230306-1530	Lower Passaic River	PSS	3/23/06	Solid	-	21.1
SS1-230306-1535	Lower Passaic River	SS1	3/23/06	Solid	-	23.4
SS2-230306-1540	Lower Passaic River	SS2	3/23/06	Solid	-	18.9
RS-230306-1545	Lower Passaic River	RS	3/23/06	Solid	-	19.7
TS-230306-0930	Lower Passaic River	TS	3/23/06	Solid	-	69.4
TS-230306-0930	Arthur Kill	TS	3/23/06	Solid	-	68.3
TSP-230306-1730	Lower Passaic River	TS	3/23/06	Solid	-	68.6

10/29/09

Table 15 Percent Moist - Solids.xls

TABLE 15

**PERCENT MOISURE/SOLIDS SAMPLE DATA SUMMARY
 DEMONSTRATION TESTING AND FULL-SCALE OPERATION OF THE
 BIOGENESIS SEDIMENT DECONTAMINATION PROCESS
 KEASBEY, NEW JERSEY**

(Page 6 of 16)

Field Sample Identification	Sediment Source	Location Identification	Date Collected	Matrix	Moisture, Percent	Solids, Percent
PSS-270306-1100	Lower Passaic River	PSS	3/27/06	Solid	-	26.2
TS-270306-1320	Lower Passaic River	TS	3/27/06	Solid	-	64.8
PSS-300306-1300	Lower Passaic River	PSS	3/30/06	Solid	-	30.9
PSS-300306-1300-AD	Lower Passaic River	PSS	3/30/06	Solid	-	97.7
PSS-300306-1300-AD	Lower Passaic River	PSS	3/30/06	Solid	-	97.7
PSS-300306-1300-DUP	Lower Passaic River	PSS	3/30/06	Solid	-	30.9
PSS-300306-1300-DUP-SE	Lower Passaic River	PSS	3/30/06	Solid	-	30.9
PSS-300306-1300-SE	Lower Passaic River	PSS	3/30/06	Solid	-	30.9
SS1-300306-1305	Lower Passaic River	SS1	3/30/06	Solid	-	62.5
SS1-300306-1305-AD	Lower Passaic River	SS1	3/30/06	Solid	-	98.1
SS1-300306-1305-DUP	Lower Passaic River	SS1	3/30/06	Solid	-	62.5
SS1-300306-1305-DUP-SE	Lower Passaic River	SS1	3/30/06	Solid	-	62.5
SS1-300306-1305-SE	Lower Passaic River	SS1	3/30/06	Solid	-	62.5
SS2-300306-1310	Lower Passaic River	SS2	3/30/06	Solid	-	58.1
SS2-300306-1310-AD	Lower Passaic River	SS2	3/30/06	Solid	-	97.2
SS2-300306-1310-DUP	Lower Passaic River	SS2	3/30/06	Solid	-	58.1
SS2-300306-1310-DUP-SE	Lower Passaic River	SS2	3/30/06	Solid	-	58.1
SS2-300306-1310-SE	Lower Passaic River	SS2	3/30/06	Solid	-	58.1
RS-300306-1315	Lower Passaic River	RS	3/30/06	Solid	-	29.3
RS-300306-1315-AD	Lower Passaic River	RS	3/30/06	Solid	-	96.7
RS-300306-1315-DUP	Lower Passaic River	RS	3/30/06	Solid	-	29.3
RS-300306-1315-DUP-SE	Lower Passaic River	RS	3/30/06	Solid	-	29.3
RS-300306-1315-SE	Lower Passaic River	RS	3/30/06	Solid	-	29.3
TS-300306-1320	Lower Passaic River	TS	3/30/06	Solid	-	67.4
TS-300306-1320-AD	Lower Passaic River	TS	3/30/06	Solid	-	99.2
TS-300306-1320-DUP	Lower Passaic River	TS	3/30/06	Solid	-	67.4
TS-300306-1320-DUP-SE	Lower Passaic River	TS	3/30/06	Solid	-	67.4
TS-300306-1320-SE	Lower Passaic River	TS	3/30/06	Solid	-	67.4
TS1-300306-1325	Lower Passaic River	TS1	3/30/06	Solid	-	58.3
TS1-300306-1325-AD	Lower Passaic River	TS1	3/30/06	Solid	-	98.2
TS1-300306-1325-DUP	Lower Passaic River	TS1	3/30/06	Solid	-	58.3

10/29/09

Table 15 Percent Moist - Solids.xls

TABLE 15

**PERCENT MOISURE/SOLIDS SAMPLE DATA SUMMARY
 DEMONSTRATION TESTING AND FULL-SCALE OPERATION OF THE
 BIOGENESIS SEDIMENT DECONTAMINATION PROCESS
 KEASBEY, NEW JERSEY**

(Page 7 of 16)

Field Sample Identification	Sediment Source	Location Identification	Date Collected	Matrix	Moisture, Percent	Solids, Percent
TS1-300306-1325-DUP-SE	Lower Passaic River	TS1	3/30/06	Solid	-	58.3
TS1-300306-1325-SE	Lower Passaic River	TS1	3/30/06	Solid	-	58.3
TS2-300306-1330	Lower Passaic River	TS2	3/30/06	Solid	-	72.1
TS2-300306-1330-AD	Lower Passaic River	TS2	3/30/06	Solid	-	99.7
TS2-300306-1330-DUP	Lower Passaic River	TS2	3/30/06	Solid	-	72.1
TS2-300306-1330-DUP-SE	Lower Passaic River	TS2	3/30/06	Solid	-	72.1
TS2-300306-1330-SE	Lower Passaic River	TS2	3/30/06	Solid	-	72.1
TS3-300306-1335	Lower Passaic River	TS3	3/30/06	Solid	-	65.1
TS3-300306-1335-AD	Lower Passaic River	TS3	3/30/06	Solid	-	98.7
TS3-300306-1335-DUP	Lower Passaic River	TS3	3/30/06	Solid	-	65.1
TS3-300306-1335-DUP-SE	Lower Passaic River	TS3	3/30/06	Solid	-	65.1
TS3-300306-1335-SE	Lower Passaic River	TS3	3/30/06	Solid	-	65.1
CENTRATE 1	Lower Passaic River	C1	3/30/06	Solid	-	4.2
CENTRATE 1-AD	Lower Passaic River	C1	3/30/06	Solid	-	12.2
CENTRATE 1-DUP	Lower Passaic River	C1	3/30/06	Solid	-	4.2
CENTRATE 1-DUP-SE	Lower Passaic River	C1	3/30/06	Solid	-	4.2
CENTRATE 1-SE	Lower Passaic River	C1	3/30/06	Solid	-	4.2
WS-300306-1345	Lower Passaic River	WS	3/30/06	Solid	-	23.2
WS-300306-1345-AD	Lower Passaic River	WS	3/30/06	Solid	-	93.3
WS-300306-1345-DUP	Lower Passaic River	WS	3/30/06	Solid	-	23.2
WS-300306-1345-DUP-SE	Lower Passaic River	WS	3/30/06	Solid	-	23.2
WS-300306-1345-SE	Lower Passaic River	WS	3/30/06	Solid	-	23.2
PSS-030406-1500	Arthur Kill	PSS	4/3/06	Solid	-	28.6
SS1-030406-1505	Arthur Kill	SS1	4/3/06	Solid	-	58.8
SS2-030406-1510	Arthur Kill	SS2	4/3/06	Solid	-	47.3
FD-431520	Arthur Kill	RS	4/3/06	Solid	-	28.8
INF-431525	Arthur Kill	RS	4/3/06	Solid	-	28.3
RS-030406-1515	Arthur Kill	RS	4/3/06	Solid	-	28.3
TS-030406-1540	Arthur Kill	TS	4/3/06	Solid	-	64.9
TS1-030406-1525	Arthur Kill	TS1	4/3/06	Solid	-	69.3
TS2-030406-1530	Arthur Kill	TS2	4/3/06	Solid	-	69

10/29/09

Table 15 Percent Moist - Solids.xls

TABLE 15

**PERCENT MOISURE/SOLIDS SAMPLE DATA SUMMARY
 DEMONSTRATION TESTING AND FULL-SCALE OPERATION OF THE
 BIOGENESIS SEDIMENT DECONTAMINATION PROCESS
 KEASBEY, NEW JERSEY**

(Page 8 of 16)

Field Sample Identification	Sediment Source	Location Identification	Date Collected	Matrix	Moisture, Percent	Solids, Percent
TS3-030406-1535	Arthur Kill	TS3	4/3/06	Solid	-	64
WS-030406-1600	Arthur Kill	WS	4/3/06	Solid	-	25.6
PSS-040406-1200	Arthur Kill	PSS	4/4/06	Solid	-	28
SS1-040406-1205	Arthur Kill	SS1	4/4/06	Solid	-	55.5
SS2-040406-1210	Arthur Kill	SS2	4/4/06	Solid	-	51.2
RS-040406-1215	Arthur Kill	RS	4/4/06	Solid	-	27.8
TS-040406-1240	Arthur Kill	TS	4/4/06	Solid	-	65.8
TS1-040406-1225	Arthur Kill	TS1	4/4/06	Solid	-	66.4
TS2-040406-1230	Arthur Kill	TS2	4/4/06	Solid	-	65.8
TS3-040406-1235	Arthur Kill	TS3	4/4/06	Solid	-	68.9
WS-040406-1300	Arthur Kill	WS	4/4/06	Solid	-	34.3
PSS-050406-1200	Arthur Kill	PSS	4/5/06	Solid	-	28.7
PSS-050406-1200	Arthur Kill	PSS	4/5/06	Solid	-	29.3
SS1-050406-1205	Arthur Kill	SS1	4/5/06	Solid	-	51.9
SS1-050406-1205	Arthur Kill	SS1	4/5/06	Solid	-	49.1
SS2-050406-1210	Arthur Kill	SS2	4/5/06	Solid	-	51.4
RS-050406-1215	Arthur Kill	RS	4/5/06	Solid	-	29.2
TS-050406-1240	Arthur Kill	TS	4/5/06	Solid	-	68.8
TS1-050406-1225	Arthur Kill	TS1	4/5/06	Solid	-	69
TS2-050406-1230	Arthur Kill	TS2	4/5/06	Solid	-	66.4
TS3-050406-1235	Arthur Kill	TS3	4/5/06	Solid	-	67
WS-050406-1300	Arthur Kill	WS	4/5/06	Solid	-	28.6
PSS-060406-1200	Arthur Kill	PSS	4/6/06	Solid	-	28.3
PSS-060406-1200	Arthur Kill	PSS	4/6/06	Solid	-	29.4
SS1-060406-1205	Arthur Kill	SS1	4/6/06	Solid	-	53.9
SS2-060406-1210	Arthur Kill	SS2	4/6/06	Solid	-	42.8
RS-060406-1215	Arthur Kill	RS	4/6/06	Solid	-	28.8
TS-060406-1240	Arthur Kill	TS	4/6/06	Solid	-	64.7
TS1-060406-1225	Arthur Kill	TS1	4/6/06	Solid	-	70.1
TS2-060406-1230	Arthur Kill	TS2	4/6/06	Solid	-	71.8
TS3-060406-1235	Arthur Kill	TS3	4/6/06	Solid	-	66.4

10/29/09

Table 15 Percent Moist - Solids.xls

TABLE 15

**PERCENT MOISURE/SOLIDS SAMPLE DATA SUMMARY
 DEMONSTRATION TESTING AND FULL-SCALE OPERATION OF THE
 BIOGENESIS SEDIMENT DECONTAMINATION PROCESS
 KEASBEY, NEW JERSEY
 (Page 9 of 16)**

Field Sample Identification	Sediment Source	Location Identification	Date Collected	Matrix	Moisture, Percent	Solids, Percent
WS-060406-1300	Arthur Kill	WS	4/6/06	Solid	-	26.4
PSS-100406-1510	Arthur Kill	PSS	4/10/06	Solid	-	28.7
SS1-100406-1515	Arthur Kill	SS1	4/10/06	Solid	-	52.6
SS2-100406-1520	Arthur Kill	SS2	4/10/06	Solid	-	47.2
RS-100406-1525	Arthur Kill	RS	4/10/06	Solid	-	29.5
TS-100406-1615	Arthur Kill	TS	4/10/06	Solid	-	66.6
TS1-100406-1600	Arthur Kill	TS1	4/10/06	Solid	-	61.3
TS2-100406-1605	Arthur Kill	TS2	4/10/06	Solid	-	74.2
TS3-100406-1610	Arthur Kill	TS3	4/10/06	Solid	-	69.3
WS-100406-1630	Arthur Kill	WS	4/10/06	Solid	-	26.1
PSS-110406-1800	Arthur Kill	PSS	4/11/06	Solid	-	27.5
SS1-110406-1805	Arthur Kill	SS1	4/11/06	Solid	-	48.2
SS2-110406-1810	Arthur Kill	SS2	4/11/06	Solid	-	45.8
RS-110406-1815	Arthur Kill	RS	4/11/06	Solid	-	28
TS-110406-1835	Arthur Kill	TS	4/11/06	Solid	-	66.8
TS1-110406-1820	Arthur Kill	TS1	4/11/06	Solid	-	66.2
TS2-110406-1825	Arthur Kill	TS2	4/11/06	Solid	-	78.1
TS3-110406-1830	Arthur Kill	TS3	4/11/06	Solid	-	68.1
WS-110406-1840	Arthur Kill	WS	4/11/06	Solid	-	25
PSS-120406-1800	Arthur Kill	PSS	4/12/06	Solid	-	28.2
SS1-120406-1805	Arthur Kill	SS1	4/12/06	Solid	-	50.8
SS2-120406-1810	Arthur Kill	SS2	4/12/06	Solid	-	47.5
RS-120406-1815	Arthur Kill	RS	4/12/06	Solid	-	28.5
TS-120406-1835	Arthur Kill	TS	4/12/06	Solid	-	66
TS1-120406-1820	Arthur Kill	TS1	4/12/06	Solid	-	67.3
TS2-120406-1825	Arthur Kill	TS2	4/12/06	Solid	-	74.9
TS3-120406-1830	Arthur Kill	TS3	4/12/06	Solid	-	68.1
WS-120406-1840	Arthur Kill	WS	4/12/06	Solid	-	28.4
PSS-130406-1700	Arthur Kill	PSS	4/13/06	Solid	-	27.4
PSS-130406-1700	Arthur Kill	PSS	4/13/06	Solid	-	26.4
SS1-130406-1705	Arthur Kill	SS1	4/13/06	Solid	-	40.5

TABLE 15

**PERCENT MOISURE/SOLIDS SAMPLE DATA SUMMARY
 DEMONSTRATION TESTING AND FULL-SCALE OPERATION OF THE
 BIOGENESIS SEDIMENT DECONTAMINATION PROCESS
 KEASBEY, NEW JERSEY
 (Page 10 of 16)**

Field Sample Identification	Sediment Source	Location Identification	Date Collected	Matrix	Moisture, Percent	Solids, Percent
SS2-130406-1710	Arthur Kill	SS2	4/13/06	Solid	-	39.2
RS-130406-1715	Arthur Kill	RS	4/13/06	Solid	-	25.3
TS-130406-1735	Arthur Kill	TS	4/13/06	Solid	-	65.2
TS1-130406-1720	Arthur Kill	TS1	4/13/06	Solid	-	63.1
TS2-130406-1725	Arthur Kill	TS2	4/13/06	Solid	-	69.6
TS3-130406-1730	Arthur Kill	TS3	4/13/06	Solid	-	65.9
WS-130406-1740	Arthur Kill	WS	4/13/06	Solid	-	27.7
PSS-170406-1700	Arthur Kill	PSS	4/17/06	Solid	-	30.6
SS1-170406-1715	Arthur Kill	SS1	4/17/06	Solid	-	55.2
SS2-170406-1720	Arthur Kill	SS2	4/17/06	Solid	-	49.2
RS-170406-1725	Arthur Kill	RS	4/17/06	Solid	-	30.2
TS-170406-1745	Arthur Kill	TS	4/17/06	Solid	-	70.3
TS1-170406-1730	Arthur Kill	TS1	4/17/06	Solid	-	66.8
TS2-170406-1735	Arthur Kill	TS2	4/17/06	Solid	-	77.9
TS3-170406-1740	Arthur Kill	TS3	4/17/06	Solid	-	68.6
WS-170406-1745	Arthur Kill	WS	4/17/06	Solid	-	28.4
PSS-180406-1700	Arthur Kill	PSS	4/18/06	Solid	-	33.8
SS1-180406-1705	Arthur Kill	SS1	4/18/06	Solid	-	42
SS2-180406-1710	Arthur Kill	SS2	4/18/06	Solid	-	39.1
RS-180406-1715	Arthur Kill	RS	4/18/06	Solid	-	27.2
TS-180406-1735	Arthur Kill	TS	4/18/06	Solid	-	70.6
TS1-180406-1720	Arthur Kill	TS1	4/18/06	Solid	-	69.2
TS2-180406-1725	Arthur Kill	TS2	4/18/06	Solid	-	70.8
TS3-180406-1730	Arthur Kill	TS3	4/18/06	Solid	-	67.9
WS-180406-1740	Arthur Kill	WS	4/18/06	Solid	-	28.2
PSS-190406-0900	Arthur Kill	PSS	4/19/06	Solid	-	25.8
PSS-190406-0900	Arthur Kill	PSS	4/19/06	Solid	-	25.9
SS1-190406-0905	Arthur Kill	SS1	4/19/06	Solid	-	40.5
SS2-190406-0910	Arthur Kill	SS2	4/19/06	Solid	-	45.9
RS-190406-0915	Arthur Kill	RS	4/19/06	Solid	-	25.6
TS-190406-0845	Arthur Kill	TS	4/19/06	Solid	-	71.5

TABLE 15

**PERCENT MOISURE/SOLIDS SAMPLE DATA SUMMARY
 DEMONSTRATION TESTING AND FULL-SCALE OPERATION OF THE
 BIOGENESIS SEDIMENT DECONTAMINATION PROCESS
 KEASBEY, NEW JERSEY**

(Page 11 of 16)

Field Sample Identification	Sediment Source	Location Identification	Date Collected	Matrix	Moisture, Percent	Solids, Percent
TS1-190406-0845	Arthur Kill	TS1	4/19/06	Solid	-	67.3
TS2-190406-0845	Arthur Kill	TS2	4/19/06	Solid	-	78.3
TS3-190406-0845	Arthur Kill	TS3	4/19/06	Solid	-	66
WS-190406-1600	Arthur Kill	WS	4/19/06	Solid	-	28
PSS-200406-1600	Arthur Kill	PSS	4/20/06	Solid	-	30.1
PSS-200406-1600	Arthur Kill	PSS	4/20/06	Solid	-	29.3
SS1-200406-1605	Arthur Kill	SS1	4/20/06	Solid	-	48.7
SS2-200406-1610	Arthur Kill	SS2	4/20/06	Solid	-	45
RS-200406-1615	Arthur Kill	RS	4/20/06	Solid	-	24
TS-200406-1635	Arthur Kill	TS	4/20/06	Solid	-	69.4
TS1-200406-1620	Arthur Kill	TS1	4/20/06	Solid	-	66
TS2-200406-1625	Arthur Kill	TS2	4/20/06	Solid	-	72.2
TS3-200406-1630	Arthur Kill	TS3	4/20/06	Solid	-	67
WS-200406-1640	Arthur Kill	WS	4/20/06	Solid	-	28
PSS-210406-1400	Arthur Kill	PSS	4/21/06	Solid	-	27.1
SS1-210406-1405	Arthur Kill	SS1	4/21/06	Solid	-	52.2
SS2-210406-1410	Arthur Kill	SS2	4/21/06	Solid	-	51.7
RS-210406-1415	Arthur Kill	RS	4/21/06	Solid	-	33.7
TS-210406-1435	Arthur Kill	TS	4/21/06	Solid	-	67.4
TS1-210406-1420	Arthur Kill	TS1	4/21/06	Solid	-	68.8
TS2-210406-1425	Arthur Kill	TS2	4/21/06	Solid	-	77.5
TS3-210406-1430	Arthur Kill	TS3	4/21/06	Solid	-	67.7
WS-210406-1440	Arthur Kill	WS	4/21/06	Solid	-	29.3
PSS-240406-1600	Arthur Kill	PSS	4/24/06	Solid	-	24.6
PSS-240406-1600	Arthur Kill	PSS	4/24/06	Solid	-	23.9
SS1-240406-1605	Arthur Kill	SS1	4/24/06	Solid	-	45.5
SS2-240406-1610	Arthur Kill	SS2	4/24/06	Solid	-	40.9
INF1-250406-1845	Arthur Kill	RS	4/24/06	Solid	-	24.3
INF1-260406-1345	Arthur Kill	RS	4/24/06	Solid	-	26.4
RS-240406-1615	Arthur Kill	RS	4/24/06	Solid	-	34
TS-240406-1635	Arthur Kill	TS	4/24/06	Solid	-	67.9

10/29/09

Table 15 Percent Moist - Solids.xls

TABLE 15

**PERCENT MOISURE/SOLIDS SAMPLE DATA SUMMARY
 DEMONSTRATION TESTING AND FULL-SCALE OPERATION OF THE
 BIOGENESIS SEDIMENT DECONTAMINATION PROCESS
 KEASBEY, NEW JERSEY
 (Page 12 of 16)**

Field Sample Identification	Sediment Source	Location Identification	Date Collected	Matrix	Moisture, Percent	Solids, Percent
TS1-240406-1620	Arthur Kill	TS1	4/24/06	Solid	-	59.5
TS2-240406-1625	Arthur Kill	TS2	4/24/06	Solid	-	70.9
TS3-240406-1630	Arthur Kill	TS3	4/24/06	Solid	-	68.6
WS-240406-1640	Arthur Kill	WS	4/24/06	Solid	-	27
PSS-250406-1800	Arthur Kill	PSS	4/25/06	Solid	-	31.4
PSS-250406-1800	Arthur Kill	PSS	4/25/06	Solid	-	30.8
SS2-250406-1810	Arthur Kill	SS2	4/25/06	Solid	-	53.5
RS-250406-1815	Arthur Kill	RS	4/25/06	Solid	-	30.7
TS-250406-1835	Arthur Kill	TS	4/25/06	Solid	-	67.6
TS1-250406-1820	Arthur Kill	TS1	4/25/06	Solid	-	67.4
TS2-250406-1825	Arthur Kill	TS2	4/25/06	Solid	-	78.8
TS3-250406-1830	Arthur Kill	TS3	4/25/06	Solid	-	67.7
WS-250406-1840	Arthur Kill	WS	4/25/06	Solid	-	29.4
PSS-260406-1300	Arthur Kill	PSS	4/26/06	Solid	-	35.7
SS1-260406-1305	Arthur Kill	SS1	4/26/06	Solid	-	67.4
SS2-260406-1310	Arthur Kill	SS2	4/26/06	Solid	-	56.8
RS-260406-1315	Arthur Kill	RS	4/26/06	Solid	-	34.3
TS-260406-1335	Arthur Kill	TS	4/26/06	Solid	-	66.6
TS1-260406-1320	Arthur Kill	TS1	4/26/06	Solid	-	66.7
TS2-260406-1325	Arthur Kill	TS2	4/26/06	Solid	-	70.1
TS3-260406-1330	Arthur Kill	TS3	4/26/06	Solid	-	68.9
WS-260406-1340	Arthur Kill	WS	4/26/06	Solid	-	25.9
PSS-270406-1700	Arthur Kill	PSS	4/27/06	Solid	-	27.8
SS1-270406-1705	Arthur Kill	SS1	4/27/06	Solid	-	44.2
SS2-270406-1710	Arthur Kill	SS2	4/27/06	Solid	-	43.8
RS-270406-1715	Arthur Kill	RS	4/27/06	Solid	-	33.9
TS-270406-1735	Arthur Kill	TS	4/27/06	Solid	-	65.4
TS1-270406-1720	Arthur Kill	TS1	4/27/06	Solid	-	69.1
TS2-270406-1725	Arthur Kill	TS2	4/27/06	Solid	-	78.6
TS3-270406-1730	Arthur Kill	TS3	4/27/06	Solid	-	66.7
WS-270406-1740	Arthur Kill	WS	4/27/06	Solid	-	24.9

TABLE 15

**PERCENT MOISURE/SOLIDS SAMPLE DATA SUMMARY
 DEMONSTRATION TESTING AND FULL-SCALE OPERATION OF THE
 BIOGENESIS SEDIMENT DECONTAMINATION PROCESS
 KEASBEY, NEW JERSEY
 (Page 13 of 16)**

Field Sample Identification	Sediment Source	Location Identification	Date Collected	Matrix	Moisture, Percent	Solids, Percent
PSS-280406-1100	Arthur Kill	PSS	4/28/06	Solid	-	27.1
PSS-280406-1100	Arthur Kill	PSS	4/28/06	Solid	-	27.3
SS1-280406-1105	Arthur Kill	SS1	4/28/06	Solid	-	59.6
SS2-280406-1110	Arthur Kill	SS2	4/28/06	Solid	-	56.6
RS-280406-1115	Arthur Kill	RS	4/28/06	Solid	-	37.8
TS-280406-1135	Arthur Kill	TS	4/28/06	Solid	-	68.8
TSGRAB-280406-0815	Arthur Kill	TS	4/28/06	Solid	-	69.9
TSGRAB-280406-1115	Arthur Kill	TS	4/28/06	Solid	-	70.4
TS1-280406-1120	Arthur Kill	TS1	4/28/06	Solid	-	70.4
TS1GRAB-280406-0800	Arthur Kill	TS1	4/28/06	Solid	-	71.9
TS1GRAB-280406-1100	Arthur Kill	TS1	4/28/06	Solid	-	70.6
TS2-280406-1125	Arthur Kill	TS2	4/28/06	Solid	-	77.9
TS2GRAB-280406-0805	Arthur Kill	TS2	4/28/06	Solid	-	77.3
TS2GRAB-280406-1105	Arthur Kill	TS2	4/28/06	Solid	-	76.6
TS3-280406-1130	Arthur Kill	TS3	4/28/06	Solid	-	68
TS3GRAB-280406-0810	Arthur Kill	TS3	4/28/06	Solid	-	66
TS3GRAB-280406-1110	Arthur Kill	TS3	4/28/06	Solid	-	67.6
WS-280406-1140	Arthur Kill	WS	4/28/06	Solid	-	25.2
PSS-010506-1600	Lower Passaic River	PSS	5/1/06	Solid	-	20.2
SS1-010506-1605	Lower Passaic River	SS1	5/1/06	Solid	-	22.3
SS2-010506-1610	Lower Passaic River	SS2	5/1/06	Solid	-	23.3
RS-010506-1615	Lower Passaic River	RS	5/1/06	Solid	-	23.7
TS-010506-1635	Lower Passaic River	TS	5/1/06	Solid	-	62.1
TS1-010506-1620	Lower Passaic River	TS1	5/1/06	Solid	-	63.1
TS1-010506-1620	Lower Passaic River	TS1	5/1/06	Solid	-	62.9
TS2-010506-1625	Lower Passaic River	TS2	5/1/06	Solid	-	73.1
TS3-010506-1630	Lower Passaic River	TS3	5/1/06	Solid	-	64.1
WS-010506-1640	Lower Passaic River	WS	5/1/06	Solid	-	26.8
PSS-020506-1600	Lower Passaic River	PSS	5/2/06	Solid	-	21.5
SS1-020506-1605	Lower Passaic River	SS1	5/2/06	Solid	-	25.3
SS2-020506-1610	Lower Passaic River	SS2	5/2/06	Solid	-	22.2

TABLE 15

**PERCENT MOISURE/SOLIDS SAMPLE DATA SUMMARY
 DEMONSTRATION TESTING AND FULL-SCALE OPERATION OF THE
 BIOGENESIS SEDIMENT DECONTAMINATION PROCESS
 KEASBEY, NEW JERSEY**

(Page 14 of 16)

Field Sample Identification	Sediment Source	Location Identification	Date Collected	Matrix	Moisture, Percent	Solids, Percent
RS-020506-1615	Lower Passaic River	RS	5/2/06	Solid	-	31
STS-1-020506-1200	Lower Passaic River	TS	5/2/06	Solid	-	64.8
STS-2-020506-1500	Lower Passaic River	TS	5/2/06	Solid	-	66
TS-020506-1635	Lower Passaic River	TS	5/2/06	Solid	-	64.7
TS1-020506-1620	Lower Passaic River	TS1	5/2/06	Solid	-	32.8
TS2-020506-1625	Lower Passaic River	TS2	5/2/06	Solid	-	70.3
TS3-020506-1630	Lower Passaic River	TS3	5/2/06	Solid	-	63.6
WS-020506-1640	Lower Passaic River	WS	5/2/06	Solid	-	27.2
PSS-030506-1600	Lower Passaic River	PSS	5/3/06	Solid	-	26.6
PSS-030506-1600	Lower Passaic River	PSS	5/3/06	Solid	-	26.8
SS1-030506-1605	Lower Passaic River	SS1	5/3/06	Solid	-	28.7
SS2-030506-1610	Lower Passaic River	SS2	5/3/06	Solid	-	25.5
RS-030506-1615	Lower Passaic River	RS	5/3/06	Solid	-	26
STS-3-030506-1200	Lower Passaic River	TS	5/3/06	Solid	-	66.1
STS-4-030506-1400	Lower Passaic River	TS	5/3/06	Solid	-	66.7
TS-030506-1635	Lower Passaic River	TS	5/3/06	Solid	-	68.2
TS1-030506-1620	Lower Passaic River	TS1	5/3/06	Solid	-	42.1
TS2-030506-1625	Lower Passaic River	TS2	5/3/06	Solid	-	70.6
TS3-030506-1630	Lower Passaic River	TS3	5/3/06	Solid	-	66.6
WS-030506-1640	Lower Passaic River	WS	5/3/06	Solid	-	26.2
PSS-040506-1600	Lower Passaic River	PSS	5/4/06	Solid	-	33.5
PSS-040506-1600	Lower Passaic River	PSS	5/4/06	Solid	-	33.5
PSS-040506-1600B	Lower Passaic River	PSS	5/4/06	Solid	-	43
SS1-040506-1605	Lower Passaic River	SS1	5/4/06	Solid	-	32.7
SS1-040506-1605B	Lower Passaic River	SS1	5/4/06	Solid	-	27
SS2-040506-1610	Lower Passaic River	SS2	5/4/06	Solid	-	31.7
SS2-040506-1610B	Lower Passaic River	SS2	5/4/06	Solid	-	36
RS-040506-1615	Lower Passaic River	RS	5/4/06	Solid	-	32.6
RS-040506-1615B	Lower Passaic River	RS	5/4/06	Solid	-	43
STS-5-040506-1200	Lower Passaic River	TS	5/4/06	Solid	-	65.9
STS-6-040506-1500	Lower Passaic River	TS	5/4/06	Solid	-	67.4

10/29/09

Table 15 Percent Moist - Solids.xls

TABLE 15

**PERCENT MOISURE/SOLIDS SAMPLE DATA SUMMARY
 DEMONSTRATION TESTING AND FULL-SCALE OPERATION OF THE
 BIOGENESIS SEDIMENT DECONTAMINATION PROCESS
 KEASBEY, NEW JERSEY
 (Page 15 of 16)**

Field Sample Identification	Sediment Source	Location Identification	Date Collected	Matrix	Moisture, Percent	Solids, Percent
TS-040506-1635	Lower Passaic River	TS	5/4/06	Solid	-	65.1
TS-040506-1635B	Lower Passaic River	TS	5/4/06	Solid	-	67
TS1-040506-1620	Lower Passaic River	TS1	5/4/06	Solid	-	33
TS1-040506-1620B	Lower Passaic River	TS1	5/4/06	Solid	-	34
TS1-040506-1620B	Lower Passaic River	TS1	5/4/06	Solid	-	33
TS2-040506-1625	Lower Passaic River	TS2	5/4/06	Solid	-	71.1
TS2-040506-1625B	Lower Passaic River	TS2	5/4/06	Solid	-	79
TS3-040506-1630	Lower Passaic River	TS3	5/4/06	Solid	-	65.3
TS3-040506-1630B	Lower Passaic River	TS3	5/4/06	Solid	-	67
WS-040506-1640	Lower Passaic River	WS	5/4/06	Solid	-	24
WS-040506-1640B	Lower Passaic River	WS	5/4/06	Solid	-	32
CARBON TANKS	None	CAR	5/10/06	Solid	-	38.5
SPC COMP-160506-1700	All	TSP	5/16/06	Solid	-	54.7
SPP COMP-170506-1030	All	TSP	5/17/06	Solid	-	70.8
TSA-260606-1350	Lower Passaic River	MSL	6/26/06	Solid	-	87.9
TSA-260606-1350	Lower Passaic River	MSL	6/26/06	Solid	-	87.9
TSE-260606-1355	Lower Passaic River	MSL	6/26/06	Solid	-	91.4
TSE-260606-1355	Lower Passaic River	MSL	6/26/06	Solid	-	91.4
TSF-260606-1400	Lower Passaic River	MSL	6/26/06	Solid	-	83.9
TSF-260606-1400	Lower Passaic River	MSL	6/26/06	Solid	-	83.9
MSL01-040107-0905	Lower Passaic River	MSL	1/4/07	Solid	28.5	-
MSL01-040107-0905	Lower Passaic River	MSL	1/4/07	Solid	-	80.4
MSL01-040107-0905	Lower Passaic River	MSL	1/4/07	Solid	-	79.2
MSL02-040107-0925	Lower Passaic River	MSL	1/4/07	Solid	20	-
MSL02-040107-0925	Lower Passaic River	MSL	1/4/07	Solid	-	80.2
MSL03-040107-0940	Lower Passaic River	MSL	1/4/07	Solid	19.7	80.6
MSL03-040107-0940	Lower Passaic River	MSL	1/4/07	Solid	-	76.9
MSL04-040107-0950	Lower Passaic River	MSL	1/4/07	Solid	22.5	-
MSL04-040107-0950	Lower Passaic River	MSL	1/4/07	Solid	-	80.3
MSL05-040107-1000	Lower Passaic River	MSL	1/4/07	Solid	20.3	-
MSL05-040107-1000	Lower Passaic River	MSL	1/4/07	Solid	-	81.9

TABLE 15

**PERCENT MOISURE/SOLIDS SAMPLE DATA SUMMARY
 DEMONSTRATION TESTING AND FULL-SCALE OPERATION OF THE
 BIOGENESIS SEDIMENT DECONTAMINATION PROCESS
 KEASBEY, NEW JERSEY**

(Page 16 of 16)

Field Sample Identification	Sediment Source	Location Identification	Date Collected	Matrix	Moisture, Percent	Solids, Percent
MSL06-040107-1015	Lower Passaic River	MSL	1/4/07	Solid	-	78
MSL06-040107-1015	Lower Passaic River	MSL	1/4/07	Solid	19.8	-
MSL07-040107-1025	Lower Passaic River	MSL	1/4/07	Solid	-	80.3
MSL07-040107-1025	Lower Passaic River	MSL	1/4/07	Solid	20.2	-
MSL08-040107-1035	Lower Passaic River	MSL	1/4/07	Solid	-	80.1
MSL08-040107-1035	Lower Passaic River	MSL	1/4/07	Solid	23.3	-
MSL09-040107-1045	Lower Passaic River	MSL	1/4/07	Solid	-	77.4
MSL09-040107-1045	Lower Passaic River	MSL	1/4/07	Solid	23.6	-
MSL10-040107-1055	Lower Passaic River	MSL	1/4/07	Solid	-	78.1
MSL10-040107-1055	Lower Passaic River	MSL	1/4/07	Solid	24.3	-
MSL11-040107-1055	Lower Passaic River	MSL	1/4/07	Solid	-	80.4
MSL11-040107-1055	Lower Passaic River	MSL	1/4/07	Solid	23.1	-
PR-B-040107-0940	Lower Passaic River	MSL	1/4/07	Solid	-	79.4
PR-C-040107-1035	Lower Passaic River	MSL	1/4/07	Solid	-	78.1
PR-D-040107-1055	Lower Passaic River	MSL	1/4/07	Solid	-	77.1
TSP1-112508-1410	Lower Passaic River	TS	11/25/08	Solid	-	77.2
TSP2-112508-1415	Lower Passaic River	TS	11/25/08	Solid	-	77.0
AD1-112508-1420	None	AD	11/25/08	Solid	-	99.8
AD2-112508-1425	None	AD	11/25/08	Solid	-	73.5
AD3-112508-1550	None	AD	11/25/08	Solid	-	98.2
MS1-112508-1600	Lower Passaic River	MSL	11/25/08	Solid	-	71.8
MS2-112508-1610	Lower Passaic River	MSL	11/25/08	Solid	-	60.3
MS3-112508-1620	Lower Passaic River	MSL	11/25/08	Solid	-	81.9
MS4-112508-1625	Lower Passaic River	MSL	11/25/08	Solid	-	75.9
MS5-112508-1630	Lower Passaic River	MSL	11/25/08	Solid	-	80.7
TS1-121908-0800	Lower Passaic River	TS	12/19/08	Solid	-	76.6
AD1-121908-0830	None	AD	12/19/08	Solid	-	95.2
AD2-121908-0820	None	AD	12/19/08	Solid	-	96.9
AD3-121908-0840	None	AD	12/19/08	Solid	-	68.3
MS1-121908-0850	Lower Passaic River	MSL	12/19/08	Solid	-	78.3

- Not Analyzed

TABLE 16

MISCELLANEOUS SOLID PARAMETERS SAMPLE DATA SUMMARY
 DEMONSTRATION TESTING AND FULL-SCALE OPERATION OF THE
 BIOGENESIS SEDIMENT DECONTAMINATION PROCESS
 KEASBEY, NEW JERSEY
 (Page 1 of 1)

Field Sample Identification		CARBON TANKS
Sediment Source		None
Location Identification		CAR
Date Collected		5/10/06
Matrix		Solid
Analyte		
Miscellaneous Solid Parameters		
Ignitability/SW1010		Negative
Ph/SW9045C		9.3
Sulfide, Total/SW9034 (mg/kg)		2040

mg/kg milligrams per kilogram.
Bold Bolded result indicates positively identified compound.

TABLE 17

**SIEVE SIZE SOLID SAMPLE DATA SUMMARY
 DEMONSTRATION TESTING AND FULL-SCALE OPERATION OF THE
 BIOGENESIS SEDIMENT DECONTAMINATION PROCESS
 KEASBEY, NEW JERSEY
 (Page 1 of 12)**

Field Sample Identification	Sediment Source	Location Identification	Date Collected	Matrix	Percent Clay	Percent Silt	Percent Sand
TS-211205-1715	Raritan River	TS	12/21/05	Solid	18.78	69.33	11.89
WS1-211205-1800	Raritan River	WS	12/21/05	Solid	24.74	68.43	6.83
TS-291205-1100	Raritan River	TS	12/29/05	Solid	14.81	48.31	36.88
WS-291205-1110	Raritan River	WS	12/29/05	Solid	33.04	58.76	8.2
RS-030106-1600	Raritan River	RS	1/3/06	Solid	29.21	56.36	14.43
TS-030106-1645	Raritan River	TS	1/3/06	Solid	14.54	59.47	25.99
WS1-030106-1615	Raritan River	WS1	1/3/06	Solid	31.95	67.56	0.49
WS2-030106-1630	Raritan River	WS2	1/3/06	Solid	30.97	62.46	6.58
RS-040106-1300	Raritan River	RS	1/4/06	Solid	28.62	54.25	17.13
TS-040106-1100	Raritan River	TS	1/4/06	Solid	22.53	61.13	16.34
WS-040106-1400	Raritan River	WS	1/4/06	Solid	28.13	69.25	2.62
RS-050106-1500	Raritan River	RS	1/5/06	Solid	29.24	55.01	15.75
TS-050106-1505	Raritan River	TS	1/5/06	Solid	22.17	67.24	10.59
WS-050106-1510	Raritan River	WS	1/5/06	Solid	33.57	63.45	2.98
RS-060106-1531	Raritan River	RS	1/6/06	Solid	33.84	58.5	7.65
TS-060106-1532	Raritan River	TS	1/6/06	Solid	18.86	58.57	22.57
WS-060106-1533	Raritan River	WS	1/6/06	Solid	34.02	58.18	7.8
RS-090106-1500	Raritan River	RS	1/9/06	Solid	30.78	54.78	14.44
TS-090106-1501	Raritan River	TS	1/9/06	Solid	19.76	67.21	13.04
WS-090106-1502	Raritan River	WS	1/9/06	Solid	29.57	65.25	5.18
RS-100106-1600	Raritan River	RS	1/10/06	Solid	31.18	55.23	13.58
TS-100106-1601	Raritan River	TS	1/10/06	Solid	3.39	17.13	79.48
WS-100106-1602	Raritan River	WS	1/10/06	Solid	27.8	66.03	6.17
RS-110106-1630	Raritan River	RS	1/11/06	Solid	29.27	56.25	14.49
TS-110106-1631	Raritan River	TS	1/11/06	Solid	17.19	42.17	40.64
RS-120106-1630	Raritan River	RS	1/12/06	Solid	32.46	54.79	12.75
TS-120106-1601	Raritan River	TS	1/12/06	Solid	10.31	32.27	57.42
WS-120106-1602	Raritan River	WS	1/12/06	Solid	26.07	70.21	3.72
RS-190106-1600	Lower Passaic River	RS	1/19/06	Solid	19.99	46.14	33.86
TS-190106-1601	Lower Passaic River	TS	1/19/06	Solid	25.44	59.71	14.84
WS-190106-1602	Lower Passaic River	WS	1/19/06	Solid	23.1	74.31	2.59
RS-240106-1530	Lower Passaic River	RS	1/24/06	Solid	16.5	53.59	29.92
TS-240106-1630	Lower Passaic River	TS	1/24/06	Solid	11.14	49.06	39.8
RS-270106-1400	Lower Passaic River	RS	1/27/06	Solid	15.19	50.03	34.78
RS-270106-1400	Lower Passaic River	RS Dup	1/27/06	Solid	17.8	56.32	25.87

TABLE 17

**SIEVE SIZE SOLID SAMPLE DATA SUMMARY
 DEMONSTRATION TESTING AND FULL-SCALE OPERATION OF THE
 BIOGENESIS SEDIMENT DECONTAMINATION PROCESS
 KEASBEY, NEW JERSEY**

(Page 2 of 12)

Field Sample Identification	Sediment Source	Location Identification	Date Collected	Matrix	Percent Clay	Percent Silt	Percent Sand
TS-270106-1401	Lower Passaic River	TS	1/27/06	Solid	6.98	39.17	53.85
TS-270106-1530	Lower Passaic River	TS	1/27/06	Solid	8.86	42.15	49
WS-270106-1402	Lower Passaic River	WS	1/27/06	Solid	20.53	73.51	5.96
WS-270106-1531	Lower Passaic River	WS	1/27/06	Solid	20.93	77.05	2.01
RS-300106-1700	Raritan River	RS	1/30/06	Solid	27.66	55.04	17.3
WS2-300106-1702	Raritan River	WS2	1/30/06	Solid	13.16	67.8	19.04
RS-310106-1700	Raritan River	RS	1/31/06	Solid	38.02	52.85	9.13
RS-310106-1700	Raritan River	RS Dup	1/31/06	Solid	37.18	53.69	9.13
TS-310106-1701	Raritan River	TS	1/31/06	Solid	20.01	45.94	34.05
WS-310106-1702	Raritan River	WS	1/31/06	Solid	32.36	61.75	5.89
RS-010206-1600	Raritan River	RS	2/1/06	Solid	28.9	54.43	16.67
RS-010206-1600	Raritan River	RS Dup	2/1/06	Solid	29.04	54.15	16.81
TS-010206-1601	Raritan River	TS	2/1/06	Solid	11.23	41.63	47.14
WS-010206-1602	Raritan River	WS	2/1/06	Solid	26.19	60.74	13.08
RS-020206-1800	Raritan River	RS	2/2/06	Solid	30.16	53.83	16.01
RS-020206-1800	Raritan River	RS Dup	2/2/06	Solid	30.69	55.56	13.76
TS-020206-1801	Raritan River	TS	2/2/06	Solid	12.03	44.04	43.92
WS-020206-1802	Raritan River	WS	2/2/06	Solid	24.93	64.87	10.21
RS-030206-1200	Raritan River	RS	2/3/06	Solid	30.26	55.31	14.43
TS-030206-1201	Raritan River	TS	2/3/06	Solid	18.66	54.89	26.45
WS-030206-1202	Raritan River	WS	2/3/06	Solid	23.99	75.72	0.29
RS-060206-1930	Raritan River	RS	2/6/06	Solid	32.51	55.36	12.13
TS-060206-1931	Raritan River	TS	2/6/06	Solid	14.01	51.41	34.58
WS-060206-1932	Raritan River	WS	2/6/06	Solid	23.09	73.55	3.36
SP-070206-1445	Raritan River	PPS	2/7/06	Solid	18.49	49.2	32.3
RS-070206-1630	Raritan River	RS	2/7/06	Solid	31.01	54.81	14.19
TS-070206-1631	Raritan River	TS	2/7/06	Solid	19.17	53.24	27.59
TS-070206-1631 DRIED	Raritan River	TS	2/7/06	Solid	18.19	59.47	22.34
WS-070206-1632	Raritan River	WS	2/7/06	Solid	25.4	66.83	7.77
RS-080206-1700	Raritan River	RS	2/8/06	Solid	27.84	51.6	20.56
TS-080206-1701	Raritan River	TS	2/8/06	Solid	23.27	55.2	21.53
WS-080206-1702	Raritan River	WS	2/8/06	Solid	28.6	70.48	0.93
RS-090206-2300	Arthur Kill	RS	2/9/06	Solid	24.3	42.95	32.75
TS-090206-2301	Arthur Kill	TS	2/9/06	Solid	13.38	43.8	42.82
WS-090206-2302	Arthur Kill	WS	2/9/06	Solid	27.7	71.34	0.97

TABLE 17

**SIEVE SIZE SOLID SAMPLE DATA SUMMARY
 DEMONSTRATION TESTING AND FULL-SCALE OPERATION OF THE
 BIOGENESIS SEDIMENT DECONTAMINATION PROCESS
 KEASBEY, NEW JERSEY**

(Page 3 of 12)

Field Sample Identification	Sediment Source	Location Identification	Date Collected	Matrix	Percent Clay	Percent Silt	Percent Sand
RS-130206-1700	Lower Passaic River	RS	2/13/06	Solid	19.7	55.2	25.1
TS-130206-1701	Lower Passaic River	TS	2/13/06	Solid	10.62	38.74	50.64
WS-130206-1702	Lower Passaic River	WS	2/13/06	Solid	33.69	65.96	0.36
RS-140206-1330	Arthur Kill	RS	2/14/06	Solid	24.89	49.22	25.9
RS-140206-1330	Arthur Kill	RS Dup	2/14/06	Solid	21.87	43.26	34.87
TS-140206-1331	Arthur Kill	TS	2/14/06	Solid	12.93	50.29	36.78
WS-140206-1332	Arthur Kill	WS	2/14/06	Solid	21.43	68.43	10.14
RS-160206-1500	Arthur Kill	RS	2/16/06	Solid	22.52	49.23	28.25
TS-160206-1501	Arthur Kill	TS	2/16/06	Solid	10.87	45.84	43.29
WS-160206-1502	Arthur Kill	WS	2/16/06	Solid	18.66	71.91	9.43
RS-170206-1100	Arthur Kill	RS	2/17/06	Solid	23.95	52.71	23.35
TS-170206-1101	Arthur Kill	TS	2/17/06	Solid	14.02	53.82	32.15
WS-170206-1102	Arthur Kill	WS	2/17/06	Solid	16.42	71.55	12.02
TS-230206-0930	Arthur Kill	TS	2/23/06	Solid	9.79	32.58	57.63
TS-230206-0930 DRIED	Arthur Kill	TS	2/23/06	Solid	11.62	38.37	50.01
RS-270206-1400	Lower Passaic River	RS	2/27/06	Solid	19.55	50.99	29.45
TS-270206-1350	Lower Passaic River	TS	2/27/06	Solid	12.64	43.61	43.75
TS-270206-1630	Lower Passaic River	TS	2/27/06	Solid	6.29	26.33	67.38
RS-280206-1700	Arthur Kill	RS	2/28/06	Solid	21.6	49.22	29.18
TS-280206-1705	Arthur Kill	TS	2/28/06	Solid	9.15	31.06	59.79
WS-280206-1710	Arthur Kill	WS	2/28/06	Solid	22.8	74.44	2.77
RS-010306-1700	Arthur Kill	RS	3/1/06	Solid	23.28	53.06	23.66
TS-010306-1705	Arthur Kill	TS	3/1/06	Solid	11.26	25.88	62.87
WS-010306-1710	Arthur Kill	WS	3/1/06	Solid	19.45	70.18	10.36
SS-020306-1400	Arthur Kill	SS1	3/2/06	Solid	24.51	53.52	21.98
RS-020306-1700	Arthur Kill	RS	3/2/06	Solid	23.35	51.38	25.27
RS-020306-1700	Arthur Kill	RS Dup	3/2/06	Solid	24.31	53.28	22.42
TS-020306-1705	Arthur Kill	TS	3/2/06	Solid	14.27	33.95	51.78
WS-020306-1710	Arthur Kill	WS	3/2/06	Solid	17.14	67.41	15.45
RS-030306-1200	Arthur Kill	RS	3/3/06	Solid	24.71	53.6	21.69
TS-030306-1205	Arthur Kill	TS	3/3/06	Solid	30.65	57.08	12.26
WS-030306-1210	Arthur Kill	WS	3/3/06	Solid	16.93	70.43	12.64
SEC SCREEN-INFLUENT	Lower Passaic River	PSS	3/16/06	Solid	17.9	52.56	29.54
SEC SCREEN-SCREENINGS	Lower Passaic River	SS1	3/16/06	Solid	19.84	59.71	20.45
SEC SCREEN-EFFLUENT	Lower Passaic River	RS	3/16/06	Solid	18.65	53.22	28.14

TABLE 17

**SIEVE SIZE SOLID SAMPLE DATA SUMMARY
 DEMONSTRATION TESTING AND FULL-SCALE OPERATION OF THE
 BIOGENESIS SEDIMENT DECONTAMINATION PROCESS
 KEASBEY, NEW JERSEY**

(Page 4 of 12)

Field Sample Identification	Sediment Source	Location Identification	Date Collected	Matrix	Percent Clay	Percent Silt	Percent Sand
HYDROCYCLONES	Lower Passaic River	TS2	3/16/06	Solid	4.93	26.57	68.51
SCALPING SCREEN	Lower Passaic River	TS1	3/16/06	Solid	14.12	35.89	49.99
HYDROCYCLONE OVERFLOW	Lower Passaic River	HO	3/16/06	Solid	21.98	59.5	18.53
PSS-210306-0915	Arthur Kill	PSS	3/21/06	Solid	19.05	47.25	33.7
SS1-210306-0920	Arthur Kill	SS1	3/21/06	Solid	21.99	55.04	22.97
SS2-210306-0925	Arthur Kill	SS2	3/21/06	Solid	16.21	37.42	46.37
RS-210306-0930	Arthur Kill	RS	3/21/06	Solid	20.95	46.47	32.59
TS-210306-1030	Arthur Kill	TS	3/21/06	Solid	18.31	59.87	21.82
TS1-210306-1035	Arthur Kill	TS1	3/21/06	Solid	6.57	8.53	84.9
TS2-210306-1040	Arthur Kill	TS2	3/21/06	Solid	0.91	15.87	83.22
TS3-210306-1045	Arthur Kill	TS3	3/21/06	Solid	24.31	66.53	9.16
TS4-210306-1130	Arthur Kill	TS	3/21/06	Solid	8.86	26.38	64.76
TS5-210306-1135	Arthur Kill	TS1	3/21/06	Solid	2.3	3.64	94.07
TS6-210306-1140	Arthur Kill	TS2	3/21/06	Solid	0.97	6.08	92.95
TS7-210306-1145	Arthur Kill	TS3	3/21/06	Solid	22.14	62.51	15.35
TS7-210306-1145	Arthur Kill	TS3 Dup	3/21/06	Solid	21.68	61.26	17.06
TS-220306-1000	Arthur Kill	TS	3/22/06	Solid	16.67	55.47	27.85
TS1-220306-1005	Arthur Kill	TS1	3/22/06	Solid	4.08	5.62	90.3
TS2-220306-1010	Arthur Kill	TS2	3/22/06	Solid	0.48	10.5	89.02
TS3-220306-1015	Arthur Kill	TS3	3/22/06	Solid	21.47	66.77	11.76
PSS-230306-1530	Lower Passaic River	PSS	3/23/06	Solid	18.89	54.17	26.94
SS1-230306-1535	Lower Passaic River	SS1	3/23/06	Solid	21.27	55.48	23.26
SS2-230306-1540	Lower Passaic River	SS2	3/23/06	Solid	12.84	34.35	52.81
RS-230306-1545	Lower Passaic River	RS	3/23/06	Solid	19.35	56.04	24.61
TS-230306-0930	Arthur Kill	TS	3/23/06	Solid	14.09	53.77	32.14
TSP-230306-1730	Lower Passaic River	TS	3/23/06	Solid	13.51	53.35	33.14
PSS-270306-1100	Lower Passaic River	PSS	3/27/06	Solid	16.94	49.74	33.33
TS-270306-1320	Lower Passaic River	TS	3/27/06	Solid	20.35	62.83	16.82
PSS-300306-1300	Lower Passaic River	PSS	3/30/06	Solid	20.9	49	30.1
PSS-300306-1300	Lower Passaic River	PSS Dup	3/30/06	Solid	21.36	49.26	29.38
SS1-300306-1305	Lower Passaic River	SS1	3/30/06	Solid	23.38	56.38	20.25
SS2-300306-1310	Lower Passaic River	SS2	3/30/06	Solid	19.26	43.66	37.08
RS-300306-1315	Lower Passaic River	RS	3/30/06	Solid	22.6	49.6	27.8
TS-300306-1320	Lower Passaic River	TS	3/30/06	Solid	18.89	63.64	17.47
TS1-300306-1325	Lower Passaic River	TS1	3/30/06	Solid	5.51	10.17	84.32

TABLE 17

**SIEVE SIZE SOLID SAMPLE DATA SUMMARY
 DEMONSTRATION TESTING AND FULL-SCALE OPERATION OF THE
 BIOGENESIS SEDIMENT DECONTAMINATION PROCESS
 KEASBEY, NEW JERSEY
 (Page 5 of 12)**

Field Sample Identification	Sediment Source	Location Identification	Date Collected	Matrix	Percent Clay	Percent Silt	Percent Sand
TS2-300306-1330	Lower Passaic River	TS2	3/30/06	Solid	0.31	14.21	85.49
TS3-300306-1335	Lower Passaic River	TS3	3/30/06	Solid	19.51	64.91	15.59
CENTRATE 1	Lower Passaic River	C1	3/30/06	Solid	52.39	43.87	3.75
WS-300306-1345	Lower Passaic River	WS	3/30/06	Solid	20.53	77.54	1.93
PSS-030406-1500	Arthur Kill	PSS	4/3/06	Solid	21.86	50.55	27.59
SS1-030406-1505	Arthur Kill	SS1	4/3/06	Solid	27.04	58.15	14.81
SS2-030406-1510	Arthur Kill	SS2	4/3/06	Solid	17.52	39.22	43.26
FD-431520	Arthur Kill	RS Dup	4/3/06	Solid	23.21	51.58	25.22
INF-431525	Arthur Kill	RS Dup	4/3/06	Solid	22.74	51.04	26.22
RS-030406-1515	Arthur Kill	RS	4/3/06	Solid	22.38	50.39	27.23
TS-030406-1540	Arthur Kill	TS	4/3/06	Solid	23.03	59.97	17
TS1-030406-1525	Arthur Kill	TS1	4/3/06	Solid	2.2	4.11	93.69
TS2-030406-1530	Arthur Kill	TS2	4/3/06	Solid	3.29	5.77	90.94
TS3-030406-1535	Arthur Kill	TS3	4/3/06	Solid	26.12	65.72	8.16
WS-030406-1600	Arthur Kill	WS	4/3/06	Solid	19.26	76.29	4.45
PSS-040406-1200	Arthur Kill	PSS	4/4/06	Solid	21.05	47.54	31.4
SS1-040406-1205	Arthur Kill	SS1	4/4/06	Solid	28.14	59.96	11.9
SS2-040406-1210	Arthur Kill	SS2	4/4/06	Solid	19.14	43.12	37.74
RS-040406-1215	Arthur Kill	RS	4/4/06	Solid	22.41	50.57	27.03
TS-040406-1240	Arthur Kill	TS	4/4/06	Solid	8.47	28.96	62.57
TS1-040406-1225	Arthur Kill	TS1	4/4/06	Solid	2.34	2.66	95
TS2-040406-1230	Arthur Kill	TS2	4/4/06	Solid	2.51	4.26	93.23
TS3-040406-1235	Arthur Kill	TS3	4/4/06	Solid	21.64	65.84	12.53
WS-040406-1300	Arthur Kill	WS	4/4/06	Solid	15.43	62.39	22.18
WS-040406-1300	Arthur Kill	WS Dup	4/4/06	Solid	15.88	62.68	21.43
PSS-050406-1200	Arthur Kill	PSS	4/5/06	Solid	21.68	49.64	28.69
SS1-050406-1205	Arthur Kill	SS1	4/5/06	Solid	21.65	56.54	21.82
SS2-050406-1210	Arthur Kill	SS2	4/5/06	Solid	17.78	41.25	40.97
RS-050406-1215	Arthur Kill	RS	4/5/06	Solid	22.67	49.39	27.94
TS-050406-1240	Arthur Kill	TS	4/5/06	Solid	21.23	62.76	16.01
TS1-050406-1225	Arthur Kill	TS1	4/5/06	Solid	3.29	5.01	91.7
TS2-050406-1230	Arthur Kill	TS2	4/5/06	Solid	2.7	4.21	93.1
TS3-050406-1235	Arthur Kill	TS3	4/5/06	Solid	20.58	63.39	16.03
WS-050406-1300	Arthur Kill	WS	4/5/06	Solid	17.74	67.97	14.3
PSS-060406-1200	Arthur Kill	PSS	4/6/06	Solid	21.56	49.07	29.37

TABLE 17

**SIEVE SIZE SOLID SAMPLE DATA SUMMARY
 DEMONSTRATION TESTING AND FULL-SCALE OPERATION OF THE
 BIOGENESIS SEDIMENT DECONTAMINATION PROCESS
 KEASBEY, NEW JERSEY**

(Page 6 of 12)

Field Sample Identification	Sediment Source	Location Identification	Date Collected	Matrix	Percent Clay	Percent Silt	Percent Sand
PSS-060406-1200	Arthur Kill	PSS Dup	4/6/06	Solid	22.94	50.55	26.51
SS1-060406-1205	Arthur Kill	SS1	4/6/06	Solid	23.24	52.47	24.29
SS2-060406-1210	Arthur Kill	SS2	4/6/06	Solid	21.25	48.5	30.25
RS-060406-1215	Arthur Kill	RS	4/6/06	Solid	22.2	49.83	27.97
TS-060406-1240	Arthur Kill	TS	4/6/06	Solid	19.68	58.92	21.4
TS1-060406-1225	Arthur Kill	TS1	4/6/06	Solid	3.88	5.58	90.54
TS2-060406-1230	Arthur Kill	TS2	4/6/06	Solid	1.04	15.02	83.94
TS3-060406-1235	Arthur Kill	TS3	4/6/06	Solid	21.99	65.84	12.17
WS-060406-1300	Arthur Kill	WS	4/6/06	Solid	20.85	76.22	2.93
PSS-100406-1510	Arthur Kill	PSS	4/10/06	Solid	22.6	49.93	27.47
SS1-100406-1515	Arthur Kill	SS1	4/10/06	Solid	22.63	56.17	21.21
SS2-100406-1520	Arthur Kill	SS2	4/10/06	Solid	16.18	33.74	50.08
RS-100406-1525	Arthur Kill	RS	4/10/06	Solid	23.6	52.46	23.94
RS-100406-1525	Arthur Kill	RS Dup	4/10/06	Solid	19.91	48.73	31.37
TS-100406-1615	Arthur Kill	TS	4/10/06	Solid	21.61	66.08	12.31
TS1-100406-1600	Arthur Kill	TS1	4/10/06	Solid	2.42	4.83	92.75
TS2-100406-1605	Arthur Kill	TS2	4/10/06	Solid	0.72	6.46	92.82
TS3-100406-1610	Arthur Kill	TS3	4/10/06	Solid	22.29	66.95	10.76
WS-100406-1630	Arthur Kill	WS	4/10/06	Solid	19.69	79.2	1.11
PSS-110406-1800	Arthur Kill	PSS	4/11/06	Solid	23.05	49.44	27.52
SS1-110406-1805	Arthur Kill	SS1	4/11/06	Solid	22.74	50.82	26.45
SS2-110406-1810	Arthur Kill	SS2	4/11/06	Solid	19.18	41.17	39.66
RS-110406-1815	Arthur Kill	RS	4/11/06	Solid	23.34	49.66	27
TS-110406-1835	Arthur Kill	TS	4/11/06	Solid	23.05	64.96	11.99
TS1-110406-1820	Arthur Kill	TS1	4/11/06	Solid	1.65	3.33	95.01
TS2-110406-1825	Arthur Kill	TS2	4/11/06	Solid	0.38	9.53	90.09
TS3-110406-1830	Arthur Kill	TS3	4/11/06	Solid	22.17	63.61	14.22
WS-110406-1840	Arthur Kill	WS	4/11/06	Solid	18.4	80.95	0.64
PSS-120406-1800	Arthur Kill	PSS	4/12/06	Solid	23.62	50.46	25.92
PSS-120406-1800	Arthur Kill	PSS Dup	4/12/06	Solid	23.11	50.04	26.85
SS1-120406-1805	Arthur Kill	SS1	4/12/06	Solid	22.23	50.64	27.14
SS2-120406-1810	Arthur Kill	SS2	4/12/06	Solid	17.42	37.57	45
RS-120406-1815	Arthur Kill	RS	4/12/06	Solid	23.49	49.39	27.12
TS-120406-1835	Arthur Kill	TS	4/12/06	Solid	12.52	40.73	46.75
TS1-120406-1820	Arthur Kill	TS1	4/12/06	Solid	1.99	4.8	93.2

TABLE 17

**SIEVE SIZE SOLID SAMPLE DATA SUMMARY
 DEMONSTRATION TESTING AND FULL-SCALE OPERATION OF THE
 BIOGENESIS SEDIMENT DECONTAMINATION PROCESS
 KEASBEY, NEW JERSEY**

(Page 7 of 12)

Field Sample Identification	Sediment Source	Location Identification	Date Collected	Matrix	Percent Clay	Percent Silt	Percent Sand
TS2-120406-1825	Arthur Kill	TS2	4/12/06	Solid	0.48	8.4	91.12
TS3-120406-1830	Arthur Kill	TS3	4/12/06	Solid	18.73	66.07	15.2
WS-120406-1840	Arthur Kill	WS	4/12/06	Solid	16.53	63.63	19.84
PSS-130406-1700	Arthur Kill	PSS	4/13/06	Solid	24.03	50.33	25.64
SS1-130406-1705	Arthur Kill	SS1	4/13/06	Solid	22.32	52.8	24.88
SS2-130406-1710	Arthur Kill	SS2	4/13/06	Solid	15.25	37.86	46.9
RS-130406-1715	Arthur Kill	RS	4/13/06	Solid	23.92	53.23	22.85
TS-130406-1735	Arthur Kill	TS	4/13/06	Solid	12.44	48.55	39.01
TS1-130406-1720	Arthur Kill	TS1	4/13/06	Solid	2.29	5.86	91.85
TS2-130406-1725	Arthur Kill	TS2	4/13/06	Solid	1.9	26.12	71.98
TS3-130406-1730	Arthur Kill	TS3	4/13/06	Solid	20.88	66.68	12.44
WS-130406-1740	Arthur Kill	WS	4/13/06	Solid	20.23	67.34	12.44
PSS-170406-1700	Arthur Kill	PSS	4/17/06	Solid	21.84	49.31	28.85
PSS-170406-1700	Arthur Kill	PSS Dup	4/17/06	Solid	21.5	48.87	29.64
SS1-170406-1715	Arthur Kill	SS1	4/17/06	Solid	20.98	53.11	25.91
SS2-170406-1720	Arthur Kill	SS2	4/17/06	Solid	13.79	32.89	53.32
RS-170406-1725	Arthur Kill	RS	4/17/06	Solid	22.86	50.7	26.43
TS-170406-1745	Arthur Kill	TS	4/17/06	Solid	19.76	63.45	16.8
TS1-170406-1730	Arthur Kill	TS1	4/17/06	Solid	2.17	5.26	92.57
TS2-170406-1735	Arthur Kill	TS2	4/17/06	Solid	0.59	7.33	92.08
TS3-170406-1740	Arthur Kill	TS3	4/17/06	Solid	20.87	68.99	10.14
WS-170406-1745	Arthur Kill	WS	4/17/06	Solid	24.51	71.18	4.32
PSS-180406-1700	Arthur Kill	PSS	4/18/06	Solid	21.87	49.19	28.94
SS1-180406-1705	Arthur Kill	SS1	4/18/06	Solid	20.39	47.73	31.88
SS2-180406-1710	Arthur Kill	SS2	4/18/06	Solid	9.71	23.65	66.64
RS-180406-1715	Arthur Kill	RS	4/18/06	Solid	16.9	38.41	44.69
TS-180406-1735	Arthur Kill	TS	4/18/06	Solid	12.06	38.28	49.67
TS1-180406-1720	Arthur Kill	TS1	4/18/06	Solid	1.4	3.66	94.94
TS2-180406-1725	Arthur Kill	TS2	4/18/06	Solid	0.88	9.09	90.03
TS3-180406-1730	Arthur Kill	TS3	4/18/06	Solid	21.57	64.81	13.62
WS-180406-1740	Arthur Kill	WS	4/18/06	Solid	25.06	72.19	2.75
PSS-190406-0900	Arthur Kill	PSS	4/19/06	Solid	22.52	49.52	27.96
SS1-190406-0905	Arthur Kill	SS1	4/19/06	Solid	20.04	45.57	34.4
SS2-190406-0910	Arthur Kill	SS2	4/19/06	Solid	19.88	43.55	36.57
RS-190406-0915	Arthur Kill	RS	4/19/06	Solid	20.9	46.56	32.54

TABLE 17

**SIEVE SIZE SOLID SAMPLE DATA SUMMARY
 DEMONSTRATION TESTING AND FULL-SCALE OPERATION OF THE
 BIOGENESIS SEDIMENT DECONTAMINATION PROCESS
 KEASBEY, NEW JERSEY**

(Page 8 of 12)

Field Sample Identification	Sediment Source	Location Identification	Date Collected	Matrix	Percent Clay	Percent Silt	Percent Sand
RS-190406-0915	Arthur Kill	RS Dup	4/19/06	Solid	21.7	48	30.3
TS-190406-0845	Arthur Kill	TS	4/19/06	Solid	11.96	38.1	49.94
TS1-190406-0845	Arthur Kill	TS1	4/19/06	Solid	4.97	9.17	85.86
TS2-190406-0845	Arthur Kill	TS2	4/19/06	Solid	0.99	17.04	81.97
TS3-190406-0845	Arthur Kill	TS3	4/19/06	Solid	23.19	68.05	8.77
WS-190406-1600	Arthur Kill	WS	4/19/06	Solid	29	69.83	1.17
PSS-200406-1600	Arthur Kill	PSS	4/20/06	Solid	6.59	4.2	2.35
SS1-200406-1605	Arthur Kill	SS1	4/20/06	Solid	3.92	2.27	1.36
SS2-200406-1610	Arthur Kill	SS2	4/20/06	Solid	4.96	2.25	1.38
RS-200406-1615	Arthur Kill	RS	4/20/06	Solid	6.98	4.35	2.36
TS-200406-1635	Arthur Kill	TS	4/20/06	Solid	9.58	5.23	2.72
TS1-200406-1620	Arthur Kill	TS1	4/20/06	Solid	26.08	2.92	0.06
TS2-200406-1625	Arthur Kill	TS2	4/20/06	Solid	22.58	17.71	9.23
TS3-200406-1630	Arthur Kill	TS3	4/20/06	Solid	0.96	0.85	0.67
WS-200406-1640	Arthur Kill	WS	4/20/06	Solid	1.07	1.01	0.72
PSS-210406-1400	Arthur Kill	PSS	4/21/06	Solid	23.07	49.21	27.72
SS1-210406-1405	Arthur Kill	SS1	4/21/06	Solid	19.22	50.62	30.15
SS2-210406-1410	Arthur Kill	SS2	4/21/06	Solid	17.86	38.92	43.22
RS-210406-1415	Arthur Kill	RS	4/21/06	Solid	23.36	48.46	28.17
TS-210406-1435	Arthur Kill	TS	4/21/06	Solid	12	41.62	46.38
TS1-210406-1420	Arthur Kill	TS1	4/21/06	Solid	1.95	4.75	93.3
TS2-210406-1425	Arthur Kill	TS2	4/21/06	Solid	0.79	16.23	82.98
TS3-210406-1430	Arthur Kill	TS3	4/21/06	Solid	21.47	67.43	11.1
WS-210406-1440	Arthur Kill	WS	4/21/06	Solid	23.24	69.55	7.21
PSS-240406-1600	Arthur Kill	PSS	4/24/06	Solid	22.72	49.8	27.48
PSS-240406-1600	Arthur Kill	PSS Dup	4/24/06	Solid	22.15	48.81	29.05
SS1-240406-1605	Arthur Kill	SS1	4/24/06	Solid	22.48	55.16	22.36
SS2-240406-1610	Arthur Kill	SS2	4/24/06	Solid	18.36	39.66	41.98
INF1-250406-1845	Arthur Kill	RS Dup	4/24/06	Solid	23.08	48.5	28.42
INF1-260406-1345	Arthur Kill	RS Dup	4/24/06	Solid	22.7	49.3	28.01
RS-240406-1615	Arthur Kill	RS	4/24/06	Solid	23.14	49.79	27.06
TS-240406-1635	Arthur Kill	TS	4/24/06	Solid	17.02	54.71	28.26
TS1-240406-1620	Arthur Kill	TS1	4/24/06	Solid	1.66	4.49	93.85
TS2-240406-1625	Arthur Kill	TS2	4/24/06	Solid	0.56	12.88	86.56
TS3-240406-1630	Arthur Kill	TS3	4/24/06	Solid	22.24	66.96	10.79

TABLE 17

**SIEVE SIZE SOLID SAMPLE DATA SUMMARY
 DEMONSTRATION TESTING AND FULL-SCALE OPERATION OF THE
 BIOGENESIS SEDIMENT DECONTAMINATION PROCESS
 KEASBEY, NEW JERSEY**

(Page 9 of 12)

Field Sample Identification	Sediment Source	Location Identification	Date Collected	Matrix	Percent Clay	Percent Silt	Percent Sand
WS-240406-1640	Arthur Kill	WS	4/24/06	Solid	22.75	74.49	2.76
PSS-250406-1800	Arthur Kill	PSS	4/25/06	Solid	22.43	48.01	29.56
SS2-250406-1810	Arthur Kill	SS2	4/25/06	Solid	36.52	57.75	5.73
RS-250406-1815	Arthur Kill	RS	4/25/06	Solid	23.94	50.45	25.61
TS-250406-1835	Arthur Kill	TS	4/25/06	Solid	22.89	60.93	16.17
TS1-250406-1820	Arthur Kill	TS1	4/25/06	Solid	2.04	5.26	92.7
TS2-250406-1825	Arthur Kill	TS2	4/25/06	Solid	0.6	10.48	88.93
TS3-250406-1830	Arthur Kill	TS3	4/25/06	Solid	24.36	66.11	9.53
WS-250406-1840	Arthur Kill	WS	4/25/06	Solid	24.9	70.86	4.24
PSS-260406-1300	Arthur Kill	PSS	4/26/06	Solid	23.32	48.16	28.52
PSS-260406-1300	Arthur Kill	PSS Dup	4/26/06	Solid	22.76	46.42	30.82
SS1-260406-1305	Arthur Kill	SS1	4/26/06	Solid	25.57	58.44	15.98
SS2-260406-1310	Arthur Kill	SS2	4/26/06	Solid	21.89	45.51	32.6
RS-260406-1315	Arthur Kill	RS	4/26/06	Solid	23.71	48.29	28
TS-260406-1335	Arthur Kill	TS	4/26/06	Solid	19.27	64.08	16.65
TS1-260406-1320	Arthur Kill	TS1	4/26/06	Solid	1.39	3.34	95.27
TS2-260406-1325	Arthur Kill	TS2	4/26/06	Solid	5.99	38.12	55.9
TS3-260406-1330	Arthur Kill	TS3	4/26/06	Solid	21.76	69.2	9.04
WS-260406-1340	Arthur Kill	WS	4/26/06	Solid	14.49	77.43	8.08
PSS-270406-1700	Arthur Kill	PSS	4/27/06	Solid	4.72	3.49	2.11
SS1-270406-1705	Arthur Kill	SS1	4/27/06	Solid	3.23	2.2	1.4
SS2-270406-1710	Arthur Kill	SS2	4/27/06	Solid	6.04	2.5	1.38
RS-270406-1715	Arthur Kill	RS	4/27/06	Solid	5.07	3.51	2.07
TS-270406-1735	Arthur Kill	TS	4/27/06	Solid	0.76	0.7	0.55
TS1-270406-1720	Arthur Kill	TS1	4/27/06	Solid	26.74	2.45	0.01
TS2-270406-1725	Arthur Kill	TS2	4/27/06	Solid	14.03	14.38	9.13
TS3-270406-1730	Arthur Kill	TS3	4/27/06	Solid	0.69	0.59	0.48
WS-270406-1740	Arthur Kill	WS	4/27/06	Solid	0.29	0.17	0.1
PSS-280406-1100	Arthur Kill	PSS	4/28/06	Solid	22.07	49.17	28.76
PSS-280406-1100	Arthur Kill	PSS Dup	4/28/06	Solid	21.47	48.26	30.27
SS1-280406-1105	Arthur Kill	SS1	4/28/06	Solid	21.41	59.03	19.56
SS2-280406-1110	Arthur Kill	SS2	4/28/06	Solid	15.64	40.06	44.29
RS-280406-1115	Arthur Kill	RS	4/28/06	Solid	22.09	49.89	28.02
TS-280406-1135	Arthur Kill	TS	4/28/06	Solid	20.58	59.26	20.17
TS1-280406-1120	Arthur Kill	TS1	4/28/06	Solid	1.05	1.84	97.11

TABLE 17

**SIEVE SIZE SOLID SAMPLE DATA SUMMARY
 DEMONSTRATION TESTING AND FULL-SCALE OPERATION OF THE
 BIOGENESIS SEDIMENT DECONTAMINATION PROCESS
 KEASBEY, NEW JERSEY
 (Page 10 of 12)**

Field Sample Identification	Sediment Source	Location Identification	Date Collected	Matrix	Percent Clay	Percent Silt	Percent Sand
TS1GRAB-280406-0800	Arthur Kill	TS1	4/28/06	Solid	2.32	5.12	92.56
TS1GRAB-280406-1100	Arthur Kill	TS1	4/28/06	Solid	1.45	3.55	95
TS2-280406-1125	Arthur Kill	TS2	4/28/06	Solid	0.73	13.41	85.85
TS2GRAB-280406-0805	Arthur Kill	TS2	4/28/06	Solid	2.42	37.87	59.71
TS2GRAB-280406-1105	Arthur Kill	TS2	4/28/06	Solid	0.73	9.22	90.06
TS3-280406-1130	Arthur Kill	TS3	4/28/06	Solid	25.18	65.74	9.08
TS3GRAB-280406-0810	Arthur Kill	TS3	4/28/06	Solid	25.27	66.3	8.44
TS3GRAB-280406-1110	Arthur Kill	TS3	4/28/06	Solid	24.05	67.5	8.45
TSGRAB-280406-0815	Arthur Kill	TS	4/28/06	Solid	12.92	42.95	44.14
TSGRAB-280406-1115	Arthur Kill	TS	4/28/06	Solid	21.97	63.4	14.63
WS-280406-1140	Arthur Kill	WS	4/28/06	Solid	17.27	80.61	2.22
PSS-010506-1600	Lower Passaic River	PSS	5/1/06	Solid	19.5	59.32	21.18
PSS-010506-1600	Lower Passaic River	PSS Dup	5/1/06	Solid	18.56	56.79	24.65
SS1-010506-1605	Lower Passaic River	SS1	5/1/06	Solid	15.09	64.51	20.4
SS2-010506-1610	Lower Passaic River	SS2	5/1/06	Solid	15.59	44.71	39.7
RS-010506-1615	Lower Passaic River	RS	5/1/06	Solid	18.76	57.07	24.17
TS-010506-1635	Lower Passaic River	TS	5/1/06	Solid	21.33	67.79	10.88
TS1-010506-1620	Lower Passaic River	TS1	5/1/06	Solid	0.99	4.74	94.27
TS2-010506-1625	Lower Passaic River	TS2	5/1/06	Solid	0.58	12.34	87.09
TS3-010506-1630	Lower Passaic River	TS3	5/1/06	Solid	20.97	69.1	9.94
WS-010506-1640	Lower Passaic River	WS	5/1/06	Solid	16.06	67.95	15.99
PSS-020506-1600	Lower Passaic River	PSS	5/2/06	Solid	19.2	57.34	23.46
SS1-020506-1605	Lower Passaic River	SS1	5/2/06	Solid	17.09	61.01	21.9
SS2-020506-1610	Lower Passaic River	SS2	5/2/06	Solid	10.23	34.67	55.1
RS-020506-1615	Lower Passaic River	RS	5/2/06	Solid	18.97	56.71	24.32
STS-1-020506-1200	Lower Passaic River	TS	5/2/06	Solid	17.21	60.51	22.27
STS-2-020506-1500	Lower Passaic River	TS	5/2/06	Solid	64.83	19.23	15.94
TS-020506-1635	Lower Passaic River	TS	5/2/06	Solid	20.02	66.29	13.69
TS1-020506-1620	Lower Passaic River	TS1	5/2/06	Solid	2.32	7.95	89.72
TS2-020506-1625	Lower Passaic River	TS2	5/2/06	Solid	0.5	19.49	80.01
TS3-020506-1630	Lower Passaic River	TS3	5/2/06	Solid	21.16	67.94	10.9
WS-020506-1640	Lower Passaic River	WS	5/2/06	Solid	22.79	72.86	4.36
PSS-030506-1600	Lower Passaic River	PSS	5/3/06	Solid	18.71	54.43	26.86
PSS-030506-1600	Lower Passaic River	PSS Dup	5/3/06	Solid	19.48	56.31	24.21
SS1-030506-1605	Lower Passaic River	SS1	5/3/06	Solid	21.36	66.57	12.07

TABLE 17

**SIEVE SIZE SOLID SAMPLE DATA SUMMARY
 DEMONSTRATION TESTING AND FULL-SCALE OPERATION OF THE
 BIOGENESIS SEDIMENT DECONTAMINATION PROCESS
 KEASBEY, NEW JERSEY
 (Page 11 of 12)**

Field Sample Identification	Sediment Source	Location Identification	Date Collected	Matrix	Percent Clay	Percent Silt	Percent Sand
SS2-030506-1610	Lower Passaic River	SS2	5/3/06	Solid	17.95	44.4	37.65
RS-030506-1615	Lower Passaic River	RS	5/3/06	Solid	19.49	56.19	24.32
STS-3-030506-1200	Lower Passaic River	TS	5/3/06	Solid	15.88	55.69	28.42
STS-4-030506-1400	Lower Passaic River	TS	5/3/06	Solid	15.35	56.63	28.03
TS-030506-1635	Lower Passaic River	TS	5/3/06	Solid	17.72	60.25	22.03
TS1-030506-1620	Lower Passaic River	TS1	5/3/06	Solid	3.62	9.16	87.21
TS2-030506-1625	Lower Passaic River	TS2	5/3/06	Solid	0.51	19.38	80.11
TS3-030506-1630	Lower Passaic River	TS3	5/3/06	Solid	17.6	63.14	19.26
WS-030506-1640	Lower Passaic River	WS	5/3/06	Solid	19.42	72.82	7.76
PSS-040506-1600	Lower Passaic River	PSS	5/4/06	Solid	18.69	55.8	25.51
SS1-040506-1605	Lower Passaic River	SS1	5/4/06	Solid	19.11	61.53	19.37
SS2-040506-1610	Lower Passaic River	SS2	5/4/06	Solid	19.95	53.23	26.82
RS-040506-1615	Lower Passaic River	RS	5/4/06	Solid	19.14	56.7	24.16
STS-5-040506-1200	Lower Passaic River	TS	5/4/06	Solid	18.29	61.86	19.85
STS-6-040506-1500	Lower Passaic River	TS	5/4/06	Solid	16.85	61.28	21.87
TS-040506-1635	Lower Passaic River	TS	5/4/06	Solid	19.61	65.66	14.73
TS1-040506-1620	Lower Passaic River	TS1	5/4/06	Solid	3.29	9.08	87.62
TS2-040506-1625	Lower Passaic River	TS2	5/4/06	Solid	2.4	26.94	70.66
TS3-040506-1630	Lower Passaic River	TS3	5/4/06	Solid	21.11	64.77	14.12
WS-040506-1640	Lower Passaic River	WS	5/4/06	Solid	18.37	79.02	2.61
MSL01-040107-0905	Lower Passaic River	MSL	1/4/07	Solid	25.07	65.61	9.32
MSL02-040107-0925	Lower Passaic River	MSL	1/4/07	Solid	23.89	61.91	14.2
MSL03-040107-0940	Lower Passaic River	MSL	1/4/07	Solid	24.61	62.61	12.78
MSL04-040107-0950	Lower Passaic River	MSL	1/4/07	Solid	24.53	63.06	12.4
MSL05-040107-1	Lower Passaic River	MSL Dup	1/4/07	Solid	22.48	57.72	19.81
MSL05-040107-1000	Lower Passaic River	MSL	1/4/07	Solid	21.37	57.32	21.31
MSL06-040107-1015	Lower Passaic River	MSL	1/4/07	Solid	22.75	61.25	16
MSL07-040107-1025	Lower Passaic River	MSL	1/4/07	Solid	22.58	61.84	15.57
MSL08-040107-1035	Lower Passaic River	MSL	1/4/07	Solid	22.91	58.91	18.18
MSL09-040107-1045	Lower Passaic River	MSL	1/4/07	Solid	22.51	60.06	17.44
MSL10-040107-1055	Lower Passaic River	MSL	1/4/07	Solid	22.65	59.93	17.42
MSL11-040107-1055	Lower Passaic River	MSL	1/4/07	Solid	23.31	60.36	16.34
TSP1-112508-1410	Lower Passaic River	TS	11/25/08	Solid	17.37	63.14	19.49
TSP2-112508-1415	Lower Passaic River	TS	11/25/08	Solid	11.84	53.65	34.5
AD1-112508-1420	None	AD	11/25/08	Solid	0	0.95	99.05

TABLE 17

**SIEVE SIZE SOLID SAMPLE DATA SUMMARY
 DEMONSTRATION TESTING AND FULL-SCALE OPERATION OF THE
 BIOGENESIS SEDIMENT DECONTAMINATION PROCESS
 KEASBEY, NEW JERSEY
 (Page 12 of 12)**

Field Sample Identification	Sediment Source	Location Identification	Date Collected	Matrix	Percent Clay	Percent Silt	Percent Sand
AD2-112508-1425	None	AD	11/25/08	Solid	0.24	11.7	88.06
AD3-112508-1550	None	AD	11/25/08	Solid	24.83	74.46	0.72
MS1-112508-1600	Lower Passaic River	MSL	11/25/08	Solid	5.81	19.5	74.69
MS2-112508-1610	Lower Passaic River	MSL	11/25/08	Solid	2.49	18.7	78.81
MS3-112508-1620	Lower Passaic River	MSL	11/25/08	Solid	2.35	17.18	80.47
MS4-112508-1625	Lower Passaic River	MSL	11/25/08	Solid	7.41	28.12	64.48
MS5-112508-1630	Lower Passaic River	MSL	11/25/08	Solid	7.07	24.43	68.5
TS1-121908-0800	Lower Passaic River	TS	12/19/08	Solid	14.04	57.72	28.24
AD1-121908-0830	None	AD	12/19/08	Solid	2.54	6.65	90.82
AD2-121908-0820	None	AD	12/19/08	Solid	24.61	73.3	2.09
AD3-121908-0840	None	AD	12/19/08	Solid	0	6.64	93.35
MS1-121908-0850	Lower Passaic River	MSL	12/19/08	Solid	6.45	25.31	68.23

TCLP ANALYSES

TABLE 18

TCLP VOLATILE ORGANIC COMPOUNDS SOLID SAMPLE DATA SUMMARY
 DEMONSTRATION TESTING AND FULL-SCALE OPERATION OF THE
 BIOGENESIS SEDIMENT DECONTAMINATION PROCESS
 KEASBEY, NEW JERSEY
 (Page 1 of 1)

Field Sample Identification	CARBON TANKS
Sediment Source	None
Location Identification	CAR
Date Collected	5/10/06
Matrix	Leachate
Analyte/Methods (Units)	
TCLP Volatile Organic Compounds/SW1311/8260B (mg/l)	
1,1-Dichloroethene	<0.05
1,2-Dichloroethane	<0.05
Benzene	<0.05
Carbon tetrachloride	<0.05
Chlorobenzene	<0.05
Chloroform	<0.05
2-Butanone (MEK)	0.14
Tetrachloroethylene (PCE)	<0.05
Trichloroethylene (TCE)	<0.05
Vinyl chloride	<0.05

mg/l milligrams per liter.

Bold Bolded result indicates positively identified compound.

TCLP Toxicity Characteristic Leaching Procedure

TABLE 19

TCLP SEMI-VOLATILE ORGANIC COMPOUNDS SOLID SAMPLE DATA SUMMARY
 DEMONSTRATION TESTING AND FULL-SCALE OPERATION OF THE
 BIOGENESIS SEDIMENT DECONTAMINATION PROCESS
 KEASBEY, NEW JERSEY
 (Page 1 of 1)

Field Sample Identification		CARBON TANKS
	Sediment Source	None
	Location Identification	CAR
	Date Collected	5/10/06
	Matrix	Leachate
Analyte/Methods (Units)		
TCLP Semi-Volatile Organic Compounds/SW1311/8270C (mg/l)		
	1,4-Dichlorobenzene	<0.05
	2,4,5-Trichlorophenol	<0.05
	2,4,6-Trichlorophenol	<0.05
	2,4-Dinitrotoluene	<0.05
	Cresols, Total	<0.05
	Hexachlorobenzene	<0.05
	Hexachlorobutadiene	<0.05
	Hexachloroethane	<0.05
	Nitrobenzene	<0.05
	Pentachlorophenol	<0.25
	Pyridine	<0.1

mg/l milligrams per liter.
 TCLP Toxicity Characteristic Leaching Procedure

TABLE 20

TCLP METALS SOLID SAMPLE DATA SUMMARY
DEMONSTRATION TESTING AND FULL-SCALE OPERATION OF THE BIOGENESIS SEDIMENT DECONTAMINATION PROCESS
KEASBEY, NEW JERSEY
 (Page 1 of 3)

Field Sample Identification	TS-140206-1331	CARBON TANKS	MSL01-040107-0905	MSL02-040107-0925	MSL03-040107-0940	MSL04-040107-0950	MSL05-040107-1000
Sediment Source	Arthur Kill	None	Lower Passaic River	Lower Passaic River	Lower Passaic River	Lower Passaic River	Lower Passaic River
Location Identification	TS	CAR	MSL	MSL	MSL	MSL	MSL
Date Collected	2/14/06	5/10/06	1/4/07	1/4/07	1/4/07	1/4/07	1/4/07
Matrix	Leachate	Leachate	Leachate	Leachate	Leachate	Leachate	Leachate
Analyte/Methods (Units)							
TCLP Metals/SW1311/6010B (mg/l)							
Arsenic	0.22 TUB	0.21 TUB	0.21 T	0.21 T	0.21 T	0.22 T	0.22 T
Barium	0.57 TB	0.053 T	0.18 TB	0.21 TB	0.19 TB	0.2 TB	0.21 TB
Cadmium	0.01 T	<0.1	0.014 T	0.0091 T	0.015 T	0.012 T	0.012 T
Chromium, Total	0.0049 T	0.0022 T	0.0046 T	0.0051 T	0.0055 T	0.0042 T	0.0057 T
Lead	0.081 T	0.097 T	0.044 T	0.058 T	0.053 T	0.058 T	0.057 T
Mercury/SW7470A	<0.0002	<0.0002	<0.0002	0.000085 T	0.000048 T	<0.0002	<0.0002
Selenium	<0.25	<0.25	<0.25	<0.25	<0.25	<0.25	<0.25
Silver	<0.5	<0.5	<0.5	<0.5	<0.5	<0.5	<0.5

Bold Bolded result indicates positively identified compound.
B Analyte detected in an associated blank.
T Analyte was positively identified but the reported concentration is estimated; reported concentration is less than the reporting limit, but greater than the method detection limit.
UB Analyte considered not detected based on associated blank data.
TCLP Toxicity Characteristic Leaching Procedure

TABLE 20

TCLP METALS SOLID SAMPLE DATA SUMMARY
DEMONSTRATION TESTING AND FULL-SCALE OPERATION OF THE BIOGENESIS SEDIMENT DECONTAMINATION PROCESS
KEASBEY, NEW JERSEY
 (Page 2 of 3)

Field Sample Identification	MSL06-040107-1015	MSL07-040107-1025	MSL08-040107-1035	MSL09-040107-1045	MSL10-040107-1055	MSL11-040107-1055	TS1-121908-0800
Sediment Source	Lower Passaic River	Lower Passaic River	Lower Passaic River	Lower Passaic River	Lower Passaic River	Lower Passaic River	Lower Passaic River
Location Identification	MSL	MSL	MSL	MSL	MSL	MSL	TS
Date Collected	1/4/07	1/4/07	1/4/07	1/4/07	1/4/07	1/4/07	12/19/08
Matrix	Leachate	Leachate	Leachate	Leachate	Leachate	Leachate	Leachate
Analyte/Methods (Units)							
TCLP Metals/SW1311/6010B (mg/l)							
Arsenic	0.2 T	0.22 T	0.22 T	0.21 T	0.23 T	0.24 T	<0.50
Barium	0.21 TB	0.19 TB	0.19 TB	0.15 TB	0.19 TB	0.17 TB	0.69 T
Cadmium	0.015 T	0.0076 T	0.0099 T	0.015 T	0.0051 T	0.003 T	<0.10
Chromium, Total	0.0054 T	0.0055 T	0.0042 T	0.0057 T	0.0052 T	0.0063 T	0.0016 T
Lead	0.052 T	0.058 T	0.061 T	0.031 T	0.053 T	0.055 T	<0.50
Mercury/SW7470A	<0.0002	0.000068 T	<0.0002	<0.0002	<0.0002	0.000069 T	<0.00020
Selenium	<0.25	<0.25	<0.25	<0.25	<0.25	<0.25	<0.25
Silver	<0.5	<0.5	<0.5	<0.5	<0.5	<0.5	<0.50

Bold Bolded result indicates positively identified compound.
B Analyte detected in an associated blank.
T Analyte was positively identified but the reported concentration is estimated; reported concentration is less than the reporting limit, but greater than the method detection limit.
UB Analyte considered not detected based on associated blank data.
TCLP Toxicity Characteristic Leaching Procedure

TABLE 20

TCLP METALS SOLID SAMPLE DATA SUMMARY
DEMONSTRATION TESTING AND FULL-SCALE OPERATION OF THE BIOGENESIS SEDIMENT DECONTAMINATION PROCESS
KEASBEY, NEW JERSEY
(Page 3 of 3)

Field Sample Identification	AD1-121908-0830	AD2-121908-0820	AD3-121908-0840	MS1-121908-0850
Sediment Source	None	None	None	Lower Passaic River
Location Identification	AD	AD	AD	MSL
Date Collected	12/19/08	12/19/08	12/19/08	12/19/08
Matrix	Leachate	Leachate	Leachate	Leachate
Analyte/Methods (Units)				
TCLP Metals/SW1311/6010B (mg/l)				
Arsenic	<0.50	<0.50	<0.50	<0.50
Barium	0.65 T	0.34 T	0.017 T	0.21 T
Cadmium	0.0014 T	<0.10	<0.10	0.0077 T
Chromium, Total	0.0014 T	0.0018 T	0.0025 T	0.0019 T
Lead	<0.50	<0.50	<0.50	<0.50
Mercury/SW7470A	<0.00020	<0.00020	<0.00020	<0.00020
Selenium	<0.25	<0.25	<0.25	<0.25
Silver	<0.50	<0.50	<0.50	<0.50

Bold Bolded result indicates positively identified compound.
B Analyte detected in an associated blank.
T Analyte was positively identified but the reported concentration is estimated; reported concentration is less than the reporting limit, but greater than the method detection limit.
UB Analyte considered not detected based on associated blank data.
TCLP Toxicity Characteristic Leaching Procedure

TABLE 21

**TCLP HERBICIDES SOLID SAMPLE DATA SUMMARY
 DEMONSTRATION TESTING AND FULL-SCALE OPERATION OF THE
 BIOGENESIS SEDIMENT DECONTAMINATION PROCESS
 KEASBEY, NEW JERSEY
 (Page 1 of 1)**

Field Sample Identification		CARBON TANKS
Sediment Source		None
Location Identification		CAR
Date Collected		5/10/06
Matrix		Leachate
Analyte/Methods (Units)		
TCLP Herbicides/SW1311/8151A (mg/l)		
2,4-D		<0.04
Silvex (2,4,5-TP)		<0.01
mg/l	milligrams per liter.	
TCLP	Toxicity Characteristic Leaching Procedure	

TABLE 22

**TCLP PESTICIDES SOLID SAMPLE DATA SUMMARY
 DEMONSTRATION TESTING AND FULL-SCALE OPERATION OF THE
 BIOGENESIS SEDIMENT DECONTAMINATION PROCESS
 KEASBEY, NEW JERSEY
 (Page 1 of 1)**

Field Sample Identification		CARBON TANKS
Sediment Source	None	
Location Identification	CAR	
Date Collected	5/10/06	
Matrix	Leachate	
Analyte/Methods (Units)		
TCLP Pesticides/SW8081A (mg/l)		
Chlordane		<0.005
Endrin		<0.0005
gamma BHC (Lindane)		<0.0005
Heptachlor		<0.0005
Heptachlor epoxide		<0.0005
Methoxychlor		<0.0005
Toxaphene		<0.02
mg/l	milligrams per liter.	
TCLP	Toxicity Characteristic Leaching Procedure	

WATER ANALYSES

TABLE 23

VOLATILE ORGANIC COMPOUNDS WATER SAMPLE DATA SUMMARY
DEMONSTRATION TESTING AND FULL-SCALE OPERATION OF THE BIOGENESIS SEDIMENT DECONTAMINATION PROCESS
KEASBEY, NEW JERSEY
 (Page 1 of 16)

Field Sample Identification	WW-030106-1200	WW-040106-1545	WW-050106-1515	WW-060106-1530	WW-090106-1530	WW-100106-1603
Date Collected Matrix	1/3/06 Water	1/4/06 Water	1/5/06 Water	1/6/06 Water	1/9/06 Water	1/10/06 Water
Analyte/Methods (Units)						
Volatile Organic Compounds/E624 (µg/l)						
1,1,1-Trichloroethane	<1.0	<1.0	<1.0	<1.0	<1	<1.0
1,1,2,2-Tetrachloroethane	<1.0	<1.0	<1.0	<1.0	<1	<1.0
1,1,2-Trichloroethane	<1.0	<1.0	<1.0	<1.0	<1	<1.0
1,1-Dichloroethane	<1.0	<1.0	<1.0	<1.0	<1	<1.0
1,1-Dichloroethene	<1.0	<1.0	<1.0	<1.0	<1	<1.0
1,2-Dichloroethane	<1.0	<1.0	<1.0	<1.0	<1	<1.0
1,2-Dichloropropane	<1.0	<1.0	<1.0	<1.0	<1	<1.0
2-Chloroethyl vinyl ether	<5.0	<5.0	<5.0	<5.0	<5	<5.0
Acrolein	<20	<20	<20	28	<20	29
Acrylonitrile	<20	<20	<20	<20	<20	<20
Benzene	<1.0	<1.0	<1.0	<1.0	<1	<1.0
Bromodichloromethane	0.22 T	<1.0	<1.0	<1.0	<1	<1.0
Bromoform	<1.0	<1.0	<1.0	<1.0	<1	<1.0
Bromomethane	<1.0	<1.0	<1.0	<1.0	<1	<1.0
Carbon tetrachloride	<1.0	<1.0	<1.0	<1.0	<1	<1.0
Chlorobenzene	<1.0	<1.0	<1.0	<1.0	<1	<1.0
Chloroethane	<1.0	<1.0	<1.0	<1.0	<1	<1.0
Chloroform	1.4	<1.0	<1.0	<1.0	<1	<1.0
Chloromethane	<1.0	<1.0	<1.0	<1.0	<1	<1.0
cis-1,3-Dichloropropene	<1.0	<1.0	<1.0	<1.0	<1	<1.0
Dibromochloromethane	<1.0	<1.0	<1.0	<1.0	<1	<1.0
Dichlorodifluoromethane	-	-	-	-	<1	-
Ethylbenzene	<1.0	<1.0	<1.0	<1.0	<1	<1.0
Methylene chloride	<1.0	<1.0	0.41 T	0.53 T	<1	<1.0
Tetrachloroethylene (PCE)	<1.0	<1.0	<1.0	<1.0	<1	<1.0
Toluene	<1.0	<1.0	<1.0	<1.0	<1	<1.0
Total, 1,3-Dichloropropene (cis and trans)	-	-	-	-	-	-
trans-1,2-Dichloroethene	<1.0	<1.0	<1.0	<1.0	<1	<1.0
trans-1,3-Dichloropropene	<1.0	<1.0	<1.0	<1.0	<1	<1.0

TABLE 23

VOLATILE ORGANIC COMPOUNDS WATER SAMPLE DATA SUMMARY
DEMONSTRATION TESTING AND FULL-SCALE OPERATION OF THE BIOGENESIS SEDIMENT DECONTAMINATION PROCESS
KEASBEY, NEW JERSEY
 (Page 2 of 16)

Field Sample Identification	WW-030106-1200	WW-040106-1545	WW-050106-1515	WW-060106-1530	WW-090106-1530	WW-100106-1603
Date Collected	1/3/06	1/4/06	1/5/06	1/6/06	1/9/06	1/10/06
Matrix	Water	Water	Water	Water	Water	Water
Analyte/Methods (Units)						
Volatile Organic Compounds/E624 (µg/l) (continued)						
Trichloroethylene (TCE)	<1.0	<1.0	<1.0	<1.0	<1	<1.0
Trichlorofluoromethane	-	-	-	-	<1	-
Vinyl chloride	<1.0	<1.0	<1.0	<1.0	<1	<1.0
Xylenes, Total	-	-	-	-	<1	-

µg/l micrograms per liter.

Bold Bolded result indicates positively identified compound.

- Not analyzed.

B Analyte detected in an associated blank.

T Analyte was positively identified but the reported concentration is estimated; reported concentration is less than the reporting limit, but greater than the method detection limit.

UB Analyte considered not detected based on associated blank data.

TABLE 23

VOLATILE ORGANIC COMPOUNDS WATER SAMPLE DATA SUMMARY
DEMONSTRATION TESTING AND FULL-SCALE OPERATION OF THE BIOGENESIS SEDIMENT DECONTAMINATION PROCESS
KEASBEY, NEW JERSEY
 (Page 3 of 16)

Field Sample Identification	WW-110106-1632	WW-120106-1603	WW-130106-1430	WW-170106-1400	WW-180106-1600	WW-190106-1603
Date Collected Matrix	1/11/06 Water	1/12/06 Water	1/13/06 Water	1/17/06 Water	1/18/06 Water	1/19/06 Water
Analyte/Methods (Units)						
Volatile Organic Compounds/E624 (µg/l)						
1,1,1-Trichloroethane	<1.0	<1.0	<1.0	<1.0	<1.0	<1.0
1,1,2,2-Tetrachloroethane	<1.0	<1.0	<1.0	<1.0	<1.0	<1.0
1,1,2-Trichloroethane	<1.0	<1.0	<1.0	<1.0	<1.0	<1.0
1,1-Dichloroethane	<1.0	<1.0	<1.0	<1.0	<1.0	<1.0
1,1-Dichloroethene	<1.0	<1.0	<1.0	<1.0	<1.0	<1.0
1,2-Dichloroethane	<1.0	<1.0	<1.0	<1.0	<1.0	<1.0
1,2-Dichloropropane	<1.0	<1.0	<1.0	<1.0	<1.0	<1.0
2-Chloroethyl vinyl ether	<5.0	<5.0	<5.0	<5.0	<5.0	<5.0
Acrolein	<20	25	<20	<20	<20	<20
Acrylonitrile	<20	<20	<20	<20	<20	<20
Benzene	<1.0	<1.0	<1.0	<1.0	<1.0	<1.0
Bromodichloromethane	<1.0	<1.0	<1.0	<1.0	<1.0	<1.0
Bromoform	<1.0	<1.0	<1.0	<1.0	<1.0	<1.0
Bromomethane	<1.0	<1.0	<1.0	<1.0	<1.0	<1.0
Carbon tetrachloride	<1.0	<1.0	<1.0	<1.0	<1.0	<1.0
Chlorobenzene	<1.0	<1.0	<1.0	<1.0	<1.0	<1.0
Chloroethane	<1.0	<1.0	<1.0	<1.0	<1.0	<1.0
Chloroform	<1.0	<1.0	<1.0	<1.0	<1.0	<1.0
Chloromethane	<1.0	<1.0	<1.0	<1.0	<1.0	<1.0
cis-1,3-Dichloropropene	<1.0	<1.0	<1.0	<1.0	-	-
Dibromochloromethane	<1.0	<1.0	<1.0	<1.0	<1.0	<1.0
Dichlorodifluoromethane	-	-	-	-	<1.0	<1.0
Ethylbenzene	<1.0	<1.0	<1.0	<1.0	<1.0	<1.0
Methylene chloride	<1.0	<1.0	<1.0	<1.0	<1.0	<1.0
Tetrachloroethylene (PCE)	<1.0	<1.0	<1.0	<1.0	<1.0	<1.0
Toluene	<1.0	<1.0	<1.0	<1.0	<1.0	<1.0
Total, 1,3-Dichloropropene (cis and trans)	-	-	-	-	<2.0	<2.0
trans-1,2-Dichloroethene	<1.0	<1.0	<1.0	<1.0	<1.0	<1.0
trans-1,3-Dichloropropene	<1.0	<1.0	<1.0	<1.0	-	-

TABLE 23

VOLATILE ORGANIC COMPOUNDS WATER SAMPLE DATA SUMMARY
DEMONSTRATION TESTING AND FULL-SCALE OPERATION OF THE BIOGENESIS SEDIMENT DECONTAMINATION PROCESS
KEASBEY, NEW JERSEY
 (Page 4 of 16)

Field Sample Identification	WW-110106-1632	WW-120106-1603	WW-130106-1430	WW-170106-1400	WW-180106-1600	WW-190106-1603
Date Collected	1/11/06	1/12/06	1/13/06	1/17/06	1/18/06	1/19/06
Matrix	Water	Water	Water	Water	Water	Water
Analyte/Methods (Units)						
Volatile Organic Compounds/E624 (µg/l) (continued)						
Trichloroethylene (TCE)	<1.0	<1.0	<1.0	<1.0	<1.0	<1.0
Trichlorofluoromethane	-	-	-	-	<1.0	<1.0
Vinyl chloride	<1.0	<1.0	<1.0	<1.0	<1.0	<1.0
Xylenes, Total	-	-	-	-	<1.0	<1.0

µg/l micrograms per liter.

Bold Bolded result indicates positively identified compound.

- Not analyzed.

B Analyte detected in an associated blank.

T Analyte was positively identified but the reported concentration is estimated; reported concentration is less than the reporting limit, but greater than the method detection limit.

UB Analyte considered not detected based on associated blank data.

TABLE 23

VOLATILE ORGANIC COMPOUNDS WATER SAMPLE DATA SUMMARY
DEMONSTRATION TESTING AND FULL-SCALE OPERATION OF THE BIOGENESIS SEDIMENT DECONTAMINATION PROCESS
KEASBEY, NEW JERSEY
 (Page 5 of 16)

Field Sample Identification	WW-200106-1530	WW-230106-1630	WW-240106-1631	WW-250106-1530	WW-300106-1703	WW-310106-1703
Date Collected Matrix	1/20/06 Water	1/23/06 Water	1/24/06 Water	1/25/06 Water	1/30/06 Water	1/31/06 Water
Analyte/Methods (Units)						
Volatile Organic Compounds/E624 (µg/l)						
1,1,1-Trichloroethane	<1	<1.0	<1.0	<1.0	<1	<1.0
1,1,2,2-Tetrachloroethane	<1	<1.0	<1.0	<1.0	<1	<1.0
1,1,2-Trichloroethane	<1	<1.0	<1.0	<1.0	<1	<1.0
1,1-Dichloroethane	<1	<1.0	<1.0	<1.0	<1	<1.0
1,1-Dichloroethene	<1	<1.0	<1.0	<1.0	<1	<1.0
1,2-Dichloroethane	<1	<1.0	<1.0	<1.0	<1	<1.0
1,2-Dichloropropane	<1	<1.0	<1.0	<1.0	<1	<1.0
2-Chloroethyl vinyl ether	<5	<5.0	<5.0	<5.0	<5	<5.0
Acrolein	<20	1.1 T	<20	<20	<20	<20
Acrylonitrile	<20	<20	<20	<20	<20	<20
Benzene	<1	<1.0	<1.0	<1.0	<1	<1.0
Bromodichloromethane	<1	<1.0	<1.0	<1.0	<1	<1.0
Bromoform	<1	<1.0	<1.0	<1.0	<1	<1.0
Bromomethane	<1	<1.0	<1.0	<1.0	<1	<1.0
Carbon tetrachloride	<1	<1.0	<1.0	<1.0	<1	<1.0
Chlorobenzene	<1	<1.0	<1.0	<1.0	<1	<1.0
Chloroethane	<1	<1.0	<1.0	<1.0	<1	<1.0
Chloroform	<1	<1.0	<1.0	<1.0	<1	<1.0
Chloromethane	<1	<1.0	<1.0	<1.0	<1	<1.0
cis-1,3-Dichloropropene	-	-	-	-	-	-
Dibromochloromethane	<1	<1.0	<1.0	<1.0	<1	<1.0
Dichlorodifluoromethane	<1	<1.0	<1.0	<1.0	<1	<1.0
Ethylbenzene	<1	<1.0	<1.0	<1.0	<1	<1.0
Methylene chloride	<1	<1.0	<1.0	<1.0	<1	<1.0
Tetrachloroethylene (PCE)	<1	<1.0	<1.0	<1.0	<1	<1.0
Toluene	<1	<1.0	<1.0	<1.0	<1	<1.0
Total, 1,3-Dichloropropene (cis and trans)	<2	<2.0	<2.0	<2.0	<2	<2.0
trans-1,2-Dichloroethene	<1	<1.0	<1.0	<1.0	<1	<1.0
trans-1,3-Dichloropropene	-	-	-	-	-	-

TABLE 23

VOLATILE ORGANIC COMPOUNDS WATER SAMPLE DATA SUMMARY
DEMONSTRATION TESTING AND FULL-SCALE OPERATION OF THE BIOGENESIS SEDIMENT DECONTAMINATION PROCESS
KEASBEY, NEW JERSEY
 (Page 6 of 16)

Field Sample Identification	WW-200106-1530	WW-230106-1630	WW-240106-1631	WW-250106-1530	WW-300106-1703	WW-310106-1703
Date Collected	1/20/06	1/23/06	1/24/06	1/25/06	1/30/06	1/31/06
Matrix	Water	Water	Water	Water	Water	Water
Analyte/Methods (Units)						
Volatile Organic Compounds/E624 (µg/l) (continued)						
Trichloroethylene (TCE)	<1	<1.0	<1.0	<1.0	<1	<1.0
Trichlorofluoromethane	<1	<1.0	<1.0	<1.0	<1	<1.0
Vinyl chloride	<1	<1.0	<1.0	<1.0	<1	<1.0
Xylenes, Total	<1	<1.0	<1.0	<1.0	<1	<1.0

µg/l micrograms per liter.

Bold Bolded result indicates positively identified compound.

- Not analyzed.

B Analyte detected in an associated blank.

T Analyte was positively identified but the reported concentration is estimated; reported concentration is less than the reporting limit, but greater than the method detection limit.

UB Analyte considered not detected based on associated blank data.

TABLE 23

VOLATILE ORGANIC COMPOUNDS WATER SAMPLE DATA SUMMARY
DEMONSTRATION TESTING AND FULL-SCALE OPERATION OF THE BIOGENESIS SEDIMENT DECONTAMINATION PROCESS
KEASBEY, NEW JERSEY
 (Page 7 of 16)

Field Sample Identification	WW-010206-1603	WW-020206-1803	WW-030206-1203	WW-070206-0930	WW-080206-0930	WW-090206-0930
Date Collected Matrix	2/1/06 Water	2/2/06 Water	2/3/06 Water	2/7/06 Water	2/8/06 Water	2/9/06 Water
Analyte/Methods (Units)						
Volatile Organic Compounds/E624 (µg/l)						
1,1,1-Trichloroethane	<1.0	<1.0	<1.0	<1.0	<1.0	<1.0
1,1,2,2-Tetrachloroethane	<1.0	<1.0	<1.0	<1.0	<1.0	<1.0
1,1,2-Trichloroethane	<1.0	<1.0	<1.0	<1.0	<1.0	<1.0
1,1-Dichloroethane	<1.0	<1.0	<1.0	<1.0	<1.0	<1.0
1,1-Dichloroethene	<1.0	<1.0	<1.0	<1.0	<1.0	<1.0
1,2-Dichloroethane	<1.0	<1.0	<1.0	<1.0	<1.0	<1.0
1,2-Dichloropropane	<1.0	<1.0	<1.0	<1.0	<1.0	<1.0
2-Chloroethyl vinyl ether	<5.0	<5.0	<5.0	<5.0	<5.0	<5.0
Acrolein	<20	<20	<20	<20	<20	<20
Acrylonitrile	<20	<20	<20	<20	<20	<20
Benzene	<1.0	<1.0	<1.0	<1.0	<1.0	<1.0
Bromodichloromethane	<1.0	<1.0	<1.0	<1.0	<1.0	<1.0
Bromoform	<1.0	<1.0	<1.0	<1.0	<1.0	<1.0
Bromomethane	<1.0	<1.0	<1.0	<1.0	<1.0	<1.0
Carbon tetrachloride	<1.0	<1.0	<1.0	<1.0	<1.0	<1.0
Chlorobenzene	<1.0	<1.0	<1.0	<1.0	<1.0	<1.0
Chloroethane	<1.0	<1.0	<1.0	<1.0	<1.0	<1.0
Chloroform	<1.0	<1.0	<1.0	<1.0	<1.0	<1.0
Chloromethane	<1.0	<1.0	<1.0	<1.0	<1.0	<1.0
cis-1,3-Dichloropropene	-	-	-	-	-	-
Dibromochloromethane	<1.0	<1.0	<1.0	<1.0	<1.0	<1.0
Dichlorodifluoromethane	<1.0	<1.0	<1.0	<1.0	<1.0	<1.0
Ethylbenzene	<1.0	<1.0	<1.0	<1.0	<1.0	<1.0
Methylene chloride	<1.0	<1.0	1.7 B	<1.0	<1.0	<1.0
Tetrachloroethylene (PCE)	<1.0	<1.0	<1.0	<1.0	<1.0	<1.0
Toluene	<1.0	<1.0	<1.0	<1.0	<1.0	<1.0
Total, 1,3-Dichloropropene (cis and trans)	<2.0	<2.0	<2.0	<2.0	<2.0	<2.0
trans-1,2-Dichloroethene	<1.0	<1.0	<1.0	<1.0	<1.0	<1.0
trans-1,3-Dichloropropene	-	-	-	-	-	-

TABLE 23

VOLATILE ORGANIC COMPOUNDS WATER SAMPLE DATA SUMMARY
DEMONSTRATION TESTING AND FULL-SCALE OPERATION OF THE BIOGENESIS SEDIMENT DECONTAMINATION PROCESS
KEASBEY, NEW JERSEY
 (Page 8 of 16)

Field Sample Identification	WW-010206-1603	WW-020206-1803	WW-030206-1203	WW-070206-0930	WW-080206-0930	WW-090206-0930
Date Collected	2/1/06	2/2/06	2/3/06	2/7/06	2/8/06	2/9/06
Matrix	Water	Water	Water	Water	Water	Water
Analyte/Methods (Units)						
Volatile Organic Compounds/E624 (µg/l) (continued)						
Trichloroethylene (TCE)	<1.0	<1.0	0.81 T	<1.0	<1.0	<1.0
Trichlorofluoromethane	<1.0	<1.0	<1.0	<1.0	<1.0	<1.0
Vinyl chloride	<1.0	<1.0	<1.0	<1.0	<1.0	<1.0
Xylenes, Total	<1.0	<1.0	<1.0	<1.0	<3.0	<1.0

µg/l micrograms per liter.

Bold Bolded result indicates positively identified compound.

- Not analyzed.

B Analyte detected in an associated blank.

T Analyte was positively identified but the reported concentration is estimated; reported concentration is less than the reporting limit, but greater than the method detection limit.

UB Analyte considered not detected based on associated blank data.

TABLE 23

VOLATILE ORGANIC COMPOUNDS WATER SAMPLE DATA SUMMARY
DEMONSTRATION TESTING AND FULL-SCALE OPERATION OF THE BIOGENESIS SEDIMENT DECONTAMINATION PROCESS
KEASBEY, NEW JERSEY
 (Page 9 of 16)

Field Sample Identification	WW-100206-1000	WW-140206-0900	WW-160206-1200	WW-170206-0900	WW-220206-1500	CARBON FILTERS- PRIMARY
Date Collected Matrix	2/10/06 Water	2/14/06 Water	2/16/06 Water	2/17/06 Water	2/22/06 Water	2/24/06 Water
Analyte/Methods (Units)						
Volatile Organic Compounds/E624 (µg/l)						
1,1,1-Trichloroethane	<1.0	<1.0	<1	<1.0	<1.0	<1.0
1,1,2,2-Tetrachloroethane	<1.0	<1.0	<1	<1.0	<1.0	<1.0
1,1,2-Trichloroethane	<1.0	<1.0	<1	<1.0	<1.0	<1.0
1,1-Dichloroethane	<1.0	<1.0	<1	<1.0	<1.0	<1.0
1,1-Dichloroethene	<1.0	<1.0	<1	<1.0	<1.0	<1.0
1,2-Dichloroethane	<1.0	<1.0	<1	<1.0	<1.0	<1.0
1,2-Dichloropropane	<1.0	<1.0	<1	<1.0	<1.0	<1.0
2-Chloroethyl vinyl ether	<5.0	<5.0	<5	<5.0	<5.0	<5.0
Acrolein	<20	<20	<20	<20	<20	<20
Acrylonitrile	<20	<20	<20	<20	<20	<20
Benzene	<1.0	<1.0	<1	<1.0	<1.0	<1.0
Bromodichloromethane	<1.0	<1.0	<1	<1.0	<1.0	<1.0
Bromoform	<1.0	<1.0	<1	<1.0	<1.0	<1.0
Bromomethane	<1.0	<1.0	<1	<1.0	<1.0	<1.0
Carbon tetrachloride	<1.0	<1.0	<1	<1.0	<1.0	<1.0
Chlorobenzene	<1.0	<1.0	<1	<1.0	<1.0	<1.0
Chloroethane	<1.0	<1.0	<1	<1.0	<1.0	<1.0
Chloroform	<1.0	<1.0	<1	<1.0	<1.0	0.35 T
Chloromethane	<1.0	<1.0	<1	<1.0	<1.0	<1.0
cis-1,3-Dichloropropene	-	-	-	-	-	-
Dibromochloromethane	<1.0	<1.0	<1	<1.0	<1.0	<1.0
Dichlorodifluoromethane	<1.0	<1.0	<1	<1.0	<1.0	<1.0
Ethylbenzene	<1.0	<1.0	<1	<1.0	<1.0	<1.0
Methylene chloride	<1.0	<1.0	<1	<1.0	0.55 T	0.75 T
Tetrachloroethylene (PCE)	<1.0	<1.0	<1	<1.0	<1.0	<1.0
Toluene	<1.0	<1.0	<1	<1.0	<1.0	<1.0
Total, 1,3-Dichloropropene (cis and trans)	<2.0	<2.0	<2	<2.0	<2.0	<2.0
trans-1,2-Dichloroethene	<1.0	<1.0	<1	<1.0	<1.0	<1.0
trans-1,3-Dichloropropene	-	-	-	-	-	-

TABLE 23

VOLATILE ORGANIC COMPOUNDS WATER SAMPLE DATA SUMMARY
DEMONSTRATION TESTING AND FULL-SCALE OPERATION OF THE BIOGENESIS SEDIMENT DECONTAMINATION PROCESS
KEASBEY, NEW JERSEY
(Page 10 of 16)

Field Sample Identification	WW-100206-1000	WW-140206-0900	WW-160206-1200	WW-170206-0900	WW-220206-1500	CARBON FILTERS- PRIMARY
Date Collected	2/10/06	2/14/06	2/16/06	2/17/06	2/22/06	2/24/06
Matrix	Water	Water	Water	Water	Water	Water
Analyte/Methods (Units)						
Volatile Organic Compounds/E624 (µg/l) (continued)						
Trichloroethylene (TCE)	<1.0	<1.0	<1	<1.0	<1.0	<1.0
Trichlorofluoromethane	<1.0	<1.0	<1	<1.0	<1.0	<1.0
Vinyl chloride	<1.0	<1.0	<1	<1.0	<1.0	<1.0
Xylenes, Total	<3.0	<3.0	<3	<3.0	<3.0	<3.0

µg/l micrograms per liter.

Bold Bolded result indicates positively identified compound.

- Not analyzed.

B Analyte detected in an associated blank.

T Analyte was positively identified but the reported concentration is estimated; reported concentration is less than the reporting limit, but greater than the method detection limit.

UB Analyte considered not detected based on associated blank data.

TABLE 23

VOLATILE ORGANIC COMPOUNDS WATER SAMPLE DATA SUMMARY
DEMONSTRATION TESTING AND FULL-SCALE OPERATION OF THE BIOGENESIS SEDIMENT DECONTAMINATION PROCESS
KEASBEY, NEW JERSEY
 (Page 11 of 16)

Field Sample Identification	WW-280206-0900	WW-010306-0900	WW-010306-0900	WW-030306-1100	WW-140306-1600	WW-150306-1700
Date Collected Matrix	2/28/06 Water	3/1/06 Water	3/2/06 Water	3/3/06 Water	3/14/06 Water	3/15/06 Water
Analyte/Methods (Units)						
Volatile Organic Compounds/E624 (µg/l)						
1,1,1-Trichloroethane	<1.0	<1.0	<1	<1.0	<1.0	<1.0
1,1,2,2-Tetrachloroethane	<1.0	<1.0	<1	<1.0	<1.0	<1.0
1,1,2-Trichloroethane	<1.0	<1.0	<1	<1.0	<1.0	<1.0
1,1-Dichloroethane	<1.0	<1.0	<1	<1.0	<1.0	<1.0
1,1-Dichloroethene	<1.0	<1.0	<1	<1.0	<1.0	<1.0
1,2-Dichloroethane	<1.0	<1.0	<1	<1.0	<1.0	<1.0
1,2-Dichloropropane	<1.0	<1.0	<1	<1.0	<1.0	<1.0
2-Chloroethyl vinyl ether	<5.0	<5.0	<5	<5.0	<5.0	<5.0
Acrolein	<20	<20	<20	<20	<20	<20
Acrylonitrile	<20	<20	<20	<20	<20	<20
Benzene	<1.0	<1.0	<1	<1.0	<1.0	<1.0
Bromodichloromethane	<1.0	<1.0	<1	<1.0	<1.0	<1.0
Bromoform	<1.0	<1.0	<1	<1.0	<1.0	<1.0
Bromomethane	<1.0	<1.0	<1	<1.0	<1.0	<1.0
Carbon tetrachloride	<1.0	<1.0	<1	<1.0	<1.0	<1.0
Chlorobenzene	<1.0	<1.0	<1	<1.0	<1.0	<1.0
Chloroethane	<1.0	<1.0	<1	<1.0	<1.0	<1.0
Chloroform	<1.0	<1.0	<1	<1.0	<1.0	<1.0
Chloromethane	<1.0	<1.0	<1	<1.0	<1.0	0.29 T
cis-1,3-Dichloropropene	-	-	-	-	-	-
Dibromochloromethane	<1.0	<1.0	<1	<1.0	<1.0	<1.0
Dichlorodifluoromethane	<1.0	<1.0	<1	<1.0	<1.0	<1.0
Ethylbenzene	<1.0	<1.0	<1	<1.0	<1.0	<1.0
Methylene chloride	<1.0	<1.0	<1	<1.0	<1.0	0.46 T
Tetrachloroethylene (PCE)	<1.0	<1.0	<1	<1.0	<1.0	<1.0
Toluene	<1.0	<1.0	<1	<1.0	<1.0	<1.0
Total, 1,3-Dichloropropene (cis and trans)	<2.0	<2.0	<2	<2.0	<2.0	<2.0
trans-1,2-Dichloroethene	<1.0	<1.0	<1	<1.0	<1.0	<1.0
trans-1,3-Dichloropropene	-	-	-	-	-	-

TABLE 23

VOLATILE ORGANIC COMPOUNDS WATER SAMPLE DATA SUMMARY
DEMONSTRATION TESTING AND FULL-SCALE OPERATION OF THE BIOGENESIS SEDIMENT DECONTAMINATION PROCESS
KEASBEY, NEW JERSEY
 (Page 12 of 16)

Field Sample Identification	WW-280206-0900	WW-010306-0900	WW-010306-0900	WW-030306-1100	WW-140306-1600	WW-150306-1700
Date Collected	2/28/06	3/1/06	3/2/06	3/3/06	3/14/06	3/15/06
Matrix	Water	Water	Water	Water	Water	Water
Analyte/Methods (Units)						
Volatile Organic Compounds/E624 (µg/l) (continued)						
Trichloroethylene (TCE)	<1.0	<1.0	<1	<1.0	<1.0	<1.0
Trichlorofluoromethane	<1.0	<1.0	<1	<1.0	<1.0	<1.0
Vinyl chloride	<1.0	<1.0	<1	<1.0	<1.0	<1.0
Xylenes, Total	<3.0	<3.0	<3	<3.0	<3.0	<3.0

µg/l micrograms per liter.

Bold Bolded result indicates positively identified compound.

- Not analyzed.

B Analyte detected in an associated blank.

T Analyte was positively identified but the reported concentration is estimated; reported concentration is less than the reporting limit, but greater than the method detection limit.

UB Analyte considered not detected based on associated blank data.

TABLE 23

VOLATILE ORGANIC COMPOUNDS WATER SAMPLE DATA SUMMARY
DEMONSTRATION TESTING AND FULL-SCALE OPERATION OF THE BIOGENESIS SEDIMENT DECONTAMINATION PROCESS
KEASBEY, NEW JERSEY
 (Page 13 of 16)

Field Sample Identification	WW-1600306-1700	WW-170306-1400	WW-300306-1300	WW-070406-1530	WW-120406-1000	WW-200406-1400
Date Collected Matrix	3/16/06 Water	3/17/06 Water	3/30/06 Water	4/7/06 Water	4/12/06 Water	4/20/06 Water
Analyte/Methods (Units)						
Volatile Organic Compounds/E624 (µg/l)						
1,1,1-Trichloroethane	<1.0	<1.0	<1.0	<1.0	<1.0	<1.0
1,1,2,2-Tetrachloroethane	<1.0	<1.0	<1.0	<1.0	<1.0	<1.0
1,1,2-Trichloroethane	<1.0	<1.0	<1.0	<1.0	<1.0	<1.0
1,1-Dichloroethane	<1.0	<1.0	<1.0	<1.0	<1.0	<1.0
1,1-Dichloroethene	<1.0	<1.0	<1.0	<1.0	<1.0	<1.0
1,2-Dichloroethane	<1.0	<1.0	<1.0	<1.0	<1.0	<1.0
1,2-Dichloropropane	<1.0	<1.0	<1.0	<1.0	<1.0	<1.0
2-Chloroethyl vinyl ether	<5.0	<5.0	<5.0	<5.0	<5.0	<5.0
Acrolein	<20	<20	<20	<20	<20	<20
Acrylonitrile	<20	<20	<20	<20	<20	<20
Benzene	<1.0	<1.0	<1.0	<1.0	<1.0	<1.0
Bromodichloromethane	<1.0	<1.0	<1.0	<1.0	<1.0	<1.0
Bromoform	<1.0	<1.0	<1.0	<1.0	<1.0	<1.0
Bromomethane	<1.0	<1.0	<1.0	<1.0	<1.0	<1.0
Carbon tetrachloride	<1.0	<1.0	<1.0	<1.0	<1.0	<1.0
Chlorobenzene	<1.0	<1.0	<1.0	<1.0	<1.0	<1.0
Chloroethane	<1.0	<1.0	<1.0	<1.0	<1.0	<1.0
Chloroform	<1.0	<1.0	<1.0	<1.0	<1.0	<1.0
Chloromethane	<1.0	<1.0	<1.0	<1.0	<1.0	<1.0
cis-1,3-Dichloropropene	-	-	-	-	-	-
Dibromochloromethane	<1.0	<1.0	<1.0	<1.0	<1.0	<1.0
Dichlorodifluoromethane	<1.0	<1.0	<1.0	<1.0	<1.0	<1.0
Ethylbenzene	<1.0	<1.0	<1.0	<1.0	<1.0	<1.0
Methylene chloride	<1.0	0.49 T	<1.0	<1.0	<1.0	<1.0
Tetrachloroethylene (PCE)	<1.0	<1.0	<1.0	<1.0	<1.0	<1.0
Toluene	<1.0	<1.0	<1.0	<1.0	<1.0	<1.0
Total, 1,3-Dichloropropene (cis and trans)	<2.0	<2.0	<2.0	<2.0	<2.0	<2.0
trans-1,2-Dichloroethene	<1.0	<1.0	<1.0	<1.0	<1.0	<1.0
trans-1,3-Dichloropropene	-	-	-	-	-	-

TABLE 23

VOLATILE ORGANIC COMPOUNDS WATER SAMPLE DATA SUMMARY
DEMONSTRATION TESTING AND FULL-SCALE OPERATION OF THE BIOGENESIS SEDIMENT DECONTAMINATION PROCESS
KEASBEY, NEW JERSEY
(Page 14 of 16)

Field Sample Identification	WW-1600306-1700	WW-170306-1400	WW-300306-1300	WW-070406-1530	WW-120406-1000	WW-200406-1400
Date Collected	3/16/06	3/17/06	3/30/06	4/7/06	4/12/06	4/20/06
Matrix	Water	Water	Water	Water	Water	Water
Analyte/Methods (Units)						
Volatile Organic Compounds/E624 (µg/l) (continued)						
Trichloroethylene (TCE)	<1.0	<1.0	<1.0	<1.0	<1.0	<1.0
Trichlorofluoromethane	<1.0	<1.0	<1.0	<1.0	<1.0	<1.0
Vinyl chloride	<1.0	<1.0	<1.0	<1.0	<1.0	<1.0
Xylenes, Total	<3.0	<3.0	<3.0	<3.0	<3.0	<3.0

µg/l micrograms per liter.

Bold Bolded result indicates positively identified compound.

- Not analyzed.

B Analyte detected in an associated blank.

T Analyte was positively identified but the reported concentration is estimated; reported concentration is less than the reporting limit, but greater than the method detection limit.

UB Analyte considered not detected based on associated blank data.

TABLE 23

VOLATILE ORGANIC COMPOUNDS WATER SAMPLE DATA SUMMARY
DEMONSTRATION TESTING AND FULL-SCALE OPERATION OF THE BIOGENESIS SEDIMENT DECONTAMINATION PROCESS
KEASBEY, NEW JERSEY
 (Page 15 of 16)

Field Sample Identification	WW-260406-1000	WW-040506-1100	WW-120506-1100	WW-170506-1100
Date Collected Matrix	4/26/06 Water	5/4/06 Water	5/12/06 Water	5/17/06 Water
Analyte/Methods (Units)				
Volatile Organic Compounds/E624 (µg/l)				
1,1,1-Trichloroethane	<1.0	<1.0	<1	<1.0
1,1,2,2-Tetrachloroethane	<1.0	<1.0	<1	<1.0
1,1,2-Trichloroethane	<1.0	<1.0	<1	<1.0
1,1-Dichloroethane	<1.0	<1.0	<1	<1.0
1,1-Dichloroethene	<1.0	<1.0	<1	<1.0
1,2-Dichloroethane	<1.0	<1.0	<1	<1.0
1,2-Dichloropropane	<1.0	<1.0	<1	<1.0
2-Chloroethyl vinyl ether	<5.0	<5.0	<5	<5.0
Acrolein	<20	<20	<20	<20
Acrylonitrile	<20	<20	<20	<20
Benzene	<1.0	<1.0	<1	<1.0
Bromodichloromethane	<1.0	<1.0	<1	<1.0
Bromoform	<1.0	<1.0	<1	<1.0
Bromomethane	<1.0	<1.0	<1	<1.0
Carbon tetrachloride	<1.0	<1.0	<1	<1.0
Chlorobenzene	<1.0	<1.0	<1	<1.0
Chloroethane	<1.0	<1.0	<1	<1.0
Chloroform	<1.0	<1.0	<1	<1.0
Chloromethane	<1.0	<1.0	<1	<1.0
cis-1,3-Dichloropropene	-	-	-	-
Dibromochloromethane	<1.0	<1.0	<1	<1.0
Dichlorodifluoromethane	<1.0	<1.0	<1	<1.0
Ethylbenzene	<1.0	<1.0	<1	<1.0
Methylene chloride	0.87 T	1.7 UB	0.79 TUB	0.56 TUB
Tetrachloroethylene (PCE)	<1.0	<1.0	<1	<1.0
Toluene	<1.0	<1.0	<1	<1.0
Total, 1,3-Dichloropropene (cis and trans)	<2.0	<2.0	<2	<2.0
trans-1,2-Dichloroethene	<1.0	<1.0	<1	<1.0
trans-1,3-Dichloropropene	-	-	-	-

TABLE 23

VOLATILE ORGANIC COMPOUNDS WATER SAMPLE DATA SUMMARY
DEMONSTRATION TESTING AND FULL-SCALE OPERATION OF THE BIOGENESIS SEDIMENT DECONTAMINATION PROCESS
KEASBEY, NEW JERSEY
(Page 16 of 16)

Field Sample Identification	WW-260406-1000	WW-040506-1100	WW-120506-1100	WW-170506-1100
Date Collected	4/26/06	5/4/06	5/12/06	5/17/06
Matrix	Water	Water	Water	Water
Analyte/Methods (Units)				
Volatile Organic Compounds/E624 (µg/l) (continued)				
Trichloroethylene (TCE)	<1.0	<1.0	<1	<1.0
Trichlorofluoromethane	<1.0	<1.0	<1	<1.0
Vinyl chloride	<1.0	<1.0	<1	<1.0
Xylenes, Total	0.44 T	<3.0	<3	<3.0

µg/l micrograms per liter.

Bold Bolded result indicates positively identified compound.

- Not analyzed.

B Analyte detected in an associated blank.

T Analyte was positively identified but the reported concentration is estimated; reported concentration is less than the reporting limit, but greater than the method detection limit.

UB Analyte considered not detected based on associated blank data.

TABLE 24

EPA 625 SEMI-VOLATILE ORGANIC COMPOUNDS WATER SAMPLE DATA SUMMARY
DEMONSTRATION TESTING AND FULL-SCALE OPERATION OF THE BIOGENESIS SEDIMENT DECONTAMINATION PROCESS
KEASBEY, NEW JERSEY
 (Page 1 of 16)

Field Sample Identification	WW-040106-1545	WW-050106-1515	WW-060106-1530	WW-090106-1530	WW-100106-1603	WW-110106-1632
Date Collected	1/4/06	1/5/06	1/6/06	1/9/06	1/10/06	1/11/06
Matrix	Water	Water	Water	Water	Water	Water
Analyte/Methods (Units)						
Semi-Volatile Organic Compounds/EPA625 (µg/l)						
1,2,4-Trichlorobenzene	<10	<10	<10	<10	<10	<10
1,2-Dichlorobenzene	<10	<10	<10	<10	<10	<10
1,2-Diphenylhydrazine	<10	<10	<10	<10	<10	<10
1,3-Dichlorobenzene	<10	<10	<10	<10	<10	<10
1,4-Dichlorobenzene	<10	<10	<10	<10	<10	<10
2,4,6-Trichlorophenol	<10	<10	<10	<10	<10	<10
2,4-Dichlorophenol	<10	<10	<10	<10	<10	<10
2,4-Dimethyl phenol	<10	<10	<10	<10	<10	<10
2,4-Dinitrophenol	<51	<51	<51	<50	<51	<52
2,4-Dinitrotoluene	<10	<10	<10	<10	<10	<10
2,6-Dinitrotoluene	<10	<10	<10	<10	<10	<10
2-Chloronaphthalene	<10	<10	<10	<10	<10	<10
2-Chlorophenol	<10	<10	<10	<10	<10	<10
2-Nitrophenol	<10	<10	<10	<10	<10	<10
3,3'-Dichlorobenzidine	<51	<51	<51	<50	<51	<52
4,6-Dinitro-2-methylphenol	<51	<51	<51	<50	<51	<52
4-Bromophenyl phenyl ether	<10	<10	<10	<10	<10	<10
4-Chloro-3-methylphenol	<10	<10	<10	<10	<10	<10
4-Chlorophenyl phenyl ether	<10	<10	<10	<10	<10	<10
4-Nitrophenol	<51	<51	<51	<50	<51	<52
Acenaphthene	<10	<10	<10	<10	<10	<10
Acenaphthylene	<10	<10	<10	<10	<10	<10
Anthracene	<10	<10	<10	<10	<10	<10
Benzidine	<100	<100	<100	<100	<100	<100
Benzo(a)anthracene	<10	<10	<10	<10	<10	<10
Benzo(a)pyrene	<10	<10	<10	<10	<10	<10
Benzo(b)fluoranthene	<10	<10	<10	<10	<10	<10
Benzo(g,h,i)perylene	<10	<10	<10	<10	<10	<10
Benzo(k)fluoranthene	<10	<10	<10	<10	<10	<10
Benzyl butyl phthalate	<10	93	<10	<10	<10	<10
bis(2-chloroethoxy) Methane	<10	<10	<10	<10	<10	<10
bis(2-chloroethyl) Ether	<10	<10	<10	<10	<10	<10

10/29/09

Table 24 EPA 625 SVOCs - Water.xls

TABLE 24

EPA 625 SEMI-VOLATILE ORGANIC COMPOUNDS WATER SAMPLE DATA SUMMARY
DEMONSTRATION TESTING AND FULL-SCALE OPERATION OF THE BIOGENESIS SEDIMENT DECONTAMINATION PROCESS
KEASBEY, NEW JERSEY
 (Page 2 of 16)

Field Sample Identification	WW-040106-1545	WW-050106-1515	WW-060106-1530	WW-090106-1530	WW-100106-1603	WW-110106-1632
Date Collected	1/4/06	1/5/06	1/6/06	1/9/06	1/10/06	1/11/06
Matrix	Water	Water	Water	Water	Water	Water
Analyte/Methods (Units)						
Semi-Volatile Organic Compounds/EPA625 (µg/l) (continued)						
bis(2-chloroisopropyl) Ether	<10	<10	<10	<10	<10	<10
bis(2-ethylhexyl) Phthalate	<10	<10	<10	<10	<10	<10
Chrysene	<10	<10	<10	<10	<10	<10
Di-n-butyl phthalate	<10	<10	<10	<10	<10	<10
Di-n-octylphthalate	<10	1.4 T	<10	<10	<10	<10
Dibenz(a,h)anthracene	<10	<10	<10	<10	<10	<10
Diethyl Phthalate	<10	<10	<10	<10	<10	<10
Dimethyl phthalate	<10	<10	<10	<10	<10	<10
Fluoranthene	<10	<10	<10	<10	<10	<10
Fluorene	<10	<10	<10	<10	<10	<10
Hexachlorobenzene	<10	<10	<10	<10	<10	<10
Hexachlorobutadiene	<10	<10	<10	<10	<10	<10
Hexachlorocyclopentadiene	<10	<10	<10	<10	<10	<10
Hexachloroethane	<10	<10	<10	<10	<10	<10
Indeno(1,2,3-c,d)Pyrene	<10	<10	<10	<10	<10	<10
Isophorone	<10	<10	<10	<10	<10	<10
n-Nitroso-di-n-propylamine	<10	<10	<10	<10	<10	<10
n-Nitrosodimethylamine	<10	<10	<10	<10	<10	<10
n-Nitrosodiphenylamine	<10	<10	<10	<10	<10	<10
Naphthalene	<10	<10	<10	<10	<10	<10
Nitrobenzene	<10	<10	<10	<10	<10	<10
Pentachlorophenol	<51	<51	<51	<50	<51	<52
Phenanthrene	<10	<10	<10	<10	<10	<10
Phenol	<10	<10	<10	<10	<10	<10
Pyrene	<10	<10	<10	<10	<10	<10

µg/l micrograms per liter.

Bold Bolded result indicates positively identified compound.

D Sample dilution required for analysis; reported values reflect the dilution.

T Analyte was positively identified but the reported concentration is estimated; reported concentration is less than the reporting limit, but greater than the method detection limit.

TABLE 24

EPA 625 SEMI-VOLATILE ORGANIC COMPOUNDS WATER SAMPLE DATA SUMMARY
DEMONSTRATION TESTING AND FULL-SCALE OPERATION OF THE BIOGENESIS SEDIMENT DECONTAMINATION PROCESS
KEASBEY, NEW JERSEY
 (Page 3 of 16)

Field Sample Identification	WW-120106-1603	WW-130106-1430	WW-170106-1400	WW-180106-1600	WW-190106-1603	WW-200106-1530
Date Collected Matrix	1/12/06 Water	1/13/06 Water	1/17/06 Water	1/18/06 Water	1/19/06 Water	1/20/06 Water
Analyte/Methods (Units)						
Semi-Volatile Organic Compounds/EPA625 (µg/l)						
1,2,4-Trichlorobenzene	<9.9	<10	<9.9	<10	<11	<10
1,2-Dichlorobenzene	<9.9	<10	<9.9	<10	<11	<10
1,2-Diphenylhydrazine	<9.9	<10	<9.9	<10	<11	<10
1,3-Dichlorobenzene	<9.9	<10	<9.9	<10	<11	<10
1,4-Dichlorobenzene	<9.9	<10	<9.9	<10	<11	<10
2,4,6-Trichlorophenol	<9.9	<10	<9.9	<10	<11	<10
2,4-Dichlorophenol	<9.9	<10	<9.9	<10	<11	<10
2,4-Dimethyl phenol	<9.9	<10	<9.9	<10	<11	<10
2,4-Dinitrophenol	<50	<50	<50	<50	<53	<52
2,4-Dinitrotoluene	<9.9	<10	<9.9	<10	<11	<10
2,6-Dinitrotoluene	<9.9	<10	<9.9	<10	<11	<10
2-Chloronaphthalene	<9.9	<10	<9.9	<10	<11	<10
2-Chlorophenol	<9.9	<10	<9.9	<10	<11	<10
2-Nitrophenol	<9.9	<10	<9.9	<10	<11	<10
3,3'-Dichlorobenzidine	<50	<50	<50	<50	<53	<52
4,6-Dinitro-2-methylphenol	<50	<50	<50	<50	<53	<52
4-Bromophenyl phenyl ether	<9.9	<10	<9.9	<10	<11	<10
4-Chloro-3-methylphenol	<9.9	<10	<9.9	<10	<11	<10
4-Chlorophenyl phenyl ether	<9.9	<10	<9.9	<10	<11	<10
4-Nitrophenol	<50	<50	<50	<50	<53	<52
Acenaphthene	<9.9	<10	<9.9	<10	<11	<10
Acenaphthylene	<9.9	<10	<9.9	<10	<11	<10
Anthracene	<9.9	<10	<9.9	<10	<11	<10
Benzidine	<99	<100	<99	<100	<110	<100
Benzo(a)anthracene	<9.9	<10	<9.9	<10	<11	<10
Benzo(a)pyrene	<9.9	<10	<9.9	<10	<11	<10
Benzo(b)fluoranthene	<9.9	<10	<9.9	<10	<11	<10
Benzo(g,h,i)perylene	<9.9	<10	<9.9	<10	<11	<10
Benzo(k)fluoranthene	<9.9	<10	<9.9	<10	<11	<10
Benzyl butyl phthalate	<9.9	<10	3.7 T	<10	<11	<10
bis(2-chloroethoxy) Methane	<9.9	<10	<9.9	<10	<11	<10
bis(2-chloroethyl) Ether	<9.9	<10	<9.9	<10	<11	<10

10/29/09

Table 24 EPA 625 SVOCs - Water.xls

TABLE 24

EPA 625 SEMI-VOLATILE ORGANIC COMPOUNDS WATER SAMPLE DATA SUMMARY
DEMONSTRATION TESTING AND FULL-SCALE OPERATION OF THE BIOGENESIS SEDIMENT DECONTAMINATION PROCESS
KEASBEY, NEW JERSEY
 (Page 4 of 16)

Field Sample Identification	WW-120106-1603	WW-130106-1430	WW-170106-1400	WW-180106-1600	WW-190106-1603	WW-200106-1530
Date Collected Matrix	1/12/06 Water	1/13/06 Water	1/17/06 Water	1/18/06 Water	1/19/06 Water	1/20/06 Water
Analyte/Methods (Units)						
Semi-Volatile Organic Compounds/EPA625 (µg/l) (continued)						
bis(2-chloroisopropyl) Ether	<9.9	<10	<9.9	<10	<11	<10
bis(2-ethylhexyl) Phthalate	<9.9	<10	2.1 T	<10	<11	<10
Chrysene	<9.9	<10	<9.9	<10	<11	<10
Di-n-butyl phthalate	<9.9	<10	<9.9	<10	<11	<10
Di-n-octylphthalate	<9.9	<10	<9.9	<10	<11	<10
Dibenz(a,h)anthracene	<9.9	<10	<9.9	<10	<11	<10
Diethyl Phthalate	<9.9	<10	<9.9	<10	<11	<10
Dimethyl phthalate	<9.9	<10	<9.9	<10	<11	<10
Fluoranthene	<9.9	<10	<9.9	<10	<11	<10
Fluorene	<9.9	<10	<9.9	<10	<11	<10
Hexachlorobenzene	<9.9	<10	<9.9	<10	<11	<10
Hexachlorobutadiene	<9.9	<10	<9.9	<10	<11	<10
Hexachlorocyclopentadiene	<9.9	<10	<9.9	<10	<11	<10
Hexachloroethane	<9.9	<10	<9.9	<10	<11	<10
Indeno(1,2,3-c,d)Pyrene	<9.9	<10	<9.9	<10	<11	<10
Isophorone	<9.9	<10	<9.9	<10	<11	<10
n-Nitroso-di-n-propylamine	<9.9	<10	<9.9	<10	<11	<10
n-Nitrosodimethylamine	<9.9	<10	<9.9	<10	<11	<10
n-Nitrosodiphenylamine	<9.9	<10	<9.9	<10	<11	<10
Naphthalene	<9.9	<10	<9.9	<10	<11	<10
Nitrobenzene	<9.9	<10	<9.9	<10	<11	<10
Pentachlorophenol	<50	<50	<50	<50	<53	<52
Phenanthrene	<9.9	<10	<9.9	<10	<11	<10
Phenol	<9.9	<10	<9.9	<10	<11	<10
Pyrene	<9.9	<10	<9.9	<10	<11	<10

µg/l micrograms per liter.

Bold Bolded result indicates positively identified compound.

D Sample dilution required for analysis; reported values reflect the dilution.

T Analyte was positively identified but the reported concentration is estimated; reported concentration is less than the reporting limit, but greater than the method detection limit.

TABLE 24

**EPA 625 SEMI-VOLATILE ORGANIC COMPOUNDS WATER SAMPLE DATA SUMMARY
 DEMONSTRATION TESTING AND FULL-SCALE OPERATION OF THE BIOGENESIS SEDIMENT DECONTAMINATION PROCESS
 KEASBEY, NEW JERSEY
 (Page 5 of 16)**

Field Sample Identification	WW-230106-1630	WW-240106-1631	WW-250106-1530	WW-300106-1703	WW-310106-1703	WW-010206-1603
Date Collected Matrix	1/23/06 Water	1/24/06 Water	1/25/06 Water	1/30/06 Water	1/31/06 Water	2/1/06 Water
Analyte/Methods (Units)						
Semi-Volatile Organic Compounds/EPA625 (µg/l)						
1,2,4-Trichlorobenzene	<10	<10	<10	<10	<10	<10
1,2-Dichlorobenzene	<10	<10	<10	<10	<10	<10
1,2-Diphenylhydrazine	<10	<10	<10	<10	<10	<10
1,3-Dichlorobenzene	<10	<10	<10	<10	<10	<10
1,4-Dichlorobenzene	<10	<10	<10	<10	<10	<10
2,4,6-Trichlorophenol	<10	<10	<10	<10	<10	<10
2,4-Dichlorophenol	<10	<10	<10	<10	<10	<10
2,4-Dimethyl phenol	<10	<10	<10	<10	<10	<10
2,4-Dinitrophenol	<52	<52	<51	<52	<51	<51
2,4-Dinitrotoluene	<10	<10	<10	<10	<10	<10
2,6-Dinitrotoluene	<10	<10	<10	<10	<10	<10
2-Chloronaphthalene	<10	<10	<10	<10	<10	<10
2-Chlorophenol	<10	<10	<10	<10	<10	<10
2-Nitrophenol	<10	<10	<10	<10	<10	<10
3,3'-Dichlorobenzidine	<52	<52	<51	<52	<51	<51
4,6-Dinitro-2-methylphenol	<52	<52	<51	<52	<51	<51
4-Bromophenyl phenyl ether	<10	<10	<10	<10	<10	<10
4-Chloro-3-methylphenol	<10	<10	<10	<10	<10	<10
4-Chlorophenyl phenyl ether	<10	<10	<10	<10	<10	<10
4-Nitrophenol	<52	<52	<51	<52	<51	<51
Acenaphthene	<10	<10	<10	<10	<10	<10
Acenaphthylene	<10	<10	<10	<10	<10	<10
Anthracene	<10	<10	<10	<10	<10	<10
Benzidine	<100	<100	<100	<100	<100	<100
Benzo(a)anthracene	<10	<10	<10	<10	<10	<10
Benzo(a)pyrene	<10	<10	<10	<10	<10	<10
Benzo(b)fluoranthene	<10	<10	<10	<10	<10	<10
Benzo(g,h,i)perylene	<10	<10	<10	<10	<10	<10
Benzo(k)fluoranthene	<10	<10	<10	<10	<10	<10
Benzyl butyl phthalate	<10	<10	<10	<10	<10	1.1 T
bis(2-chloroethoxy) Methane	<10	<10	<10	<10	<10	<10
bis(2-chloroethyl) Ether	<10	<10	<10	<10	<10	<10

10/29/09

Table 24 EPA 625 SVOCs - Water.xls

TABLE 24

EPA 625 SEMI-VOLATILE ORGANIC COMPOUNDS WATER SAMPLE DATA SUMMARY
DEMONSTRATION TESTING AND FULL-SCALE OPERATION OF THE BIOGENESIS SEDIMENT DECONTAMINATION PROCESS
KEASBEY, NEW JERSEY
 (Page 6 of 16)

Field Sample Identification	WW-230106-1630	WW-240106-1631	WW-250106-1530	WW-300106-1703	WW-310106-1703	WW-010206-1603
Date Collected	1/23/06	1/24/06	1/25/06	1/30/06	1/31/06	2/1/06
Matrix	Water	Water	Water	Water	Water	Water
Analyte/Methods (Units)						
Semi-Volatile Organic Compounds/EPA625 (µg/l) (continued)						
bis(2-chloroisopropyl) Ether	<10	<10	<10	<10	<10	<10
bis(2-ethylhexyl) Phthalate	0.95 T	<10	<10	<10	<10	<10
Chrysene	<10	<10	<10	<10	<10	<10
Di-n-butyl phthalate	<10	<10	<10	<10	<10	<10
Di-n-octylphthalate	<10	<10	<10	<10	<10	<10
Dibenz(a,h)anthracene	<10	<10	<10	<10	<10	<10
Diethyl Phthalate	1.2 T	<10	<10	<10	<10	<10
Dimethyl phthalate	<10	<10	<10	<10	<10	<10
Fluoranthene	<10	<10	<10	<10	<10	<10
Fluorene	<10	<10	<10	<10	<10	<10
Hexachlorobenzene	<10	<10	<10	<10	<10	<10
Hexachlorobutadiene	<10	<10	<10	<10	<10	<10
Hexachlorocyclopentadiene	<10	<10	<10	<10	<10	<10
Hexachloroethane	<10	<10	<10	<10	<10	<10
Indeno(1,2,3-c,d)Pyrene	<10	<10	<10	<10	<10	<10
Isophorone	<10	<10	<10	<10	<10	<10
n-Nitroso-di-n-propylamine	<10	<10	<10	<10	<10	<10
n-Nitrosodimethylamine	<10	<10	<10	<10	<10	<10
n-Nitrosodiphenylamine	<10	<10	<10	<10	<10	<10
Naphthalene	2.6 T	<10	<10	<10	<10	<10
Nitrobenzene	<10	<10	<10	<10	<10	<10
Pentachlorophenol	<52	<52	<51	<52	<51	<51
Phenanthrene	<10	<10	<10	<10	<10	<10
Phenol	<10	<10	<10	<10	<10	<10
Pyrene	<10	<10	<10	<10	<10	<10

µg/l micrograms per liter.

Bold Bolded result indicates positively identified compound.

D Sample dilution required for analysis; reported values reflect the dilution.

T Analyte was positively identified but the reported concentration is estimated; reported concentration is less than the reporting limit, but greater than the method detection limit.

TABLE 24

EPA 625 SEMI-VOLATILE ORGANIC COMPOUNDS WATER SAMPLE DATA SUMMARY
DEMONSTRATION TESTING AND FULL-SCALE OPERATION OF THE BIOGENESIS SEDIMENT DECONTAMINATION PROCESS
KEASBEY, NEW JERSEY
 (Page 7 of 16)

Field Sample Identification	WW-020206-1803	WW-030206-1203	WW-070206-0930	WW-080206-0930	WW-090206-0930	WW-140206-0900
Date Collected	2/2/06	2/3/06	2/7/06	2/8/06	2/9/06	2/14/06
Matrix	Water	Water	Water	Water	Water	Water
Analyte/Methods (Units)						
Semi-Volatile Organic Compounds/EPA625 (µg/l)						
1,2,4-Trichlorobenzene	<10	<11	<10	<10	<10	<10
1,2-Dichlorobenzene	<10	<11	<10	<10	<10	<10
1,2-Diphenylhydrazine	<10	<11	<10	<10	<10	<10
1,3-Dichlorobenzene	<10	<11	<10	<10	<10	<10
1,4-Dichlorobenzene	<10	<11	<10	<10	<10	<10
2,4,6-Trichlorophenol	<10	<11	<10	<10	<10	<10
2,4-Dichlorophenol	<10	<11	<10	<10	<10	<10
2,4-Dimethyl phenol	<10	<11	<10	<10	<10	<10
2,4-Dinitrophenol	<52	<53	<50	<51	<52	<50
2,4-Dinitrotoluene	<10	<11	<10	<10	<10	<10
2,6-Dinitrotoluene	<10	<11	<10	<10	<10	<10
2-Chloronaphthalene	<10	<11	<10	<10	<10	<10
2-Chlorophenol	<10	<11	<10	<10	<10	<10
2-Nitrophenol	<10	<11	<10	<10	<10	<10
3,3'-Dichlorobenzidine	<52	<53	<50	<51	<52	<50
4,6-Dinitro-2-methylphenol	<52	<53	<50	<51	<52	<50
4-Bromophenyl phenyl ether	<10	<11	<10	<10	<10	<10
4-Chloro-3-methylphenol	<10	<11	<10	<10	<10	<10
4-Chlorophenyl phenyl ether	<10	<11	<10	<10	<10	<10
4-Nitrophenol	<52	<53	<50	<51	<52	<50
Acenaphthene	<10	<11	<10	<10	<10	<10
Acenaphthylene	<10	<11	<10	<10	<10	<10
Anthracene	<10	<11	<10	<10	<10	<10
Benzidine	<100	<110	<100	<1000	<100	<100
Benzo(a)anthracene	<10	<11	<10	<10	<10	<10
Benzo(a)pyrene	<10	<11	<10	<10	<10	<10
Benzo(b)fluoranthene	<10	<11	<10	<10	<10	<10
Benzo(g,h,i)perylene	<10	<11	<10	<10	<10	<10
Benzo(k)fluoranthene	<10	<11	<10	<10	<10	<10
Benzyl butyl phthalate	1.5 T	<11	<10	<10	1.5 T	<10
bis(2-chloroethoxy) Methane	<10	<11	<10	<10	<10	<10
bis(2-chloroethyl) Ether	<10	<11	<10	<10	<10	<10

10/29/09

Table 24 EPA 625 SVOCs - Water.xls

TABLE 24

**EPA 625 SEMI-VOLATILE ORGANIC COMPOUNDS WATER SAMPLE DATA SUMMARY
 DEMONSTRATION TESTING AND FULL-SCALE OPERATION OF THE BIOGENESIS SEDIMENT DECONTAMINATION PROCESS
 KEASBEY, NEW JERSEY
 (Page 8 of 16)**

Field Sample Identification	WW-020206-1803	WW-030206-1203	WW-070206-0930	WW-080206-0930	WW-090206-0930	WW-140206-0900
Date Collected	2/2/06	2/3/06	2/7/06	2/8/06	2/9/06	2/14/06
Matrix	Water	Water	Water	Water	Water	Water
Analyte/Methods (Units)						
Semi-Volatile Organic Compounds/EPA625 (µg/l) (continued)						
bis(2-chloroisopropyl) Ether	<10	<11	<10	<10	<10	<10
bis(2-ethylhexyl) Phthalate	<10	<11	<10	<10	<10	<10
Chrysene	<10	<11	<10	<10	<10	<10
Di-n-butyl phthalate	<10	<11	<10	<10	<10	<10
Di-n-octylphthalate	<10	<11	<10	<10	<10	<10
Dibenz(a,h)anthracene	<10	<11	<10	<10	<10	<10
Diethyl Phthalate	<10	<11	<10	<10	<10	<10
Dimethyl phthalate	<10	<11	<10	<10	<10	<10
Fluoranthene	<10	<11	<10	<10	<10	<10
Fluorene	<10	<11	<10	<10	<10	<10
Hexachlorobenzene	<10	<11	<10	<10	<10	<10
Hexachlorobutadiene	<10	<11	<10	<10	<10	<10
Hexachlorocyclopentadiene	<10	<11	<10	<10	<10	<10
Hexachloroethane	<10	<11	<10	<10	<10	<10
Indeno(1,2,3-c,d)Pyrene	<10	<11	<10	<10	<10	<10
Isophorone	<10	<11	<10	<10	<10	<10
n-Nitroso-di-n-propylamine	<10	<11	<10	<10	<10	<10
n-Nitrosodimethylamine	<10	<11	<10	<10	<10	<10
n-Nitrosodiphenylamine	<10	<11	<10	<10	<10	<10
Naphthalene	<10	<11	<10	<10	<10	<10
Nitrobenzene	<10	<11	<10	<10	<10	<10
Pentachlorophenol	<52	<53	<50	<51	<52	<50
Phenanthrene	<10	<11	<10	<10	<10	<10
Phenol	<10	<11	<10	<10	<10	<10
Pyrene	<10	<11	<10	<10	<10	<10

µg/l micrograms per liter.

Bold Bolded result indicates positively identified compound.

D Sample dilution required for analysis; reported values reflect the dilution.

T Analyte was positively identified but the reported concentration is estimated; reported concentration is less than the reporting limit, but greater than the method detection limit.

TABLE 24

EPA 625 SEMI-VOLATILE ORGANIC COMPOUNDS WATER SAMPLE DATA SUMMARY
DEMONSTRATION TESTING AND FULL-SCALE OPERATION OF THE BIOGENESIS SEDIMENT DECONTAMINATION PROCESS
KEASBEY, NEW JERSEY
 (Page 9 of 16)

Field Sample Identification	WW-160206-1200	WW-170206-0900	WW-220206-1500	CARBON FILTERS- PRIMARY	WW-280206-0900	WW-010306-0900
Date Collected Matrix	2/16/06 Water	2/17/06 Water	2/22/06 Water	2/24/06 Water	2/28/06 Water	3/1/06 Water
Analyte/Methods (Units)						
Semi-Volatile Organic Compounds/EPA625 (µg/l)						
1,2,4-Trichlorobenzene	<10	<11	<10	<9.8	<10	<10
1,2-Dichlorobenzene	<10	<11	<10	<9.8	<10	<10
1,2-Diphenylhydrazine	<10	<11	<10	<9.8	<10	<10
1,3-Dichlorobenzene	<10	<11	<10	<9.8	<10	<10
1,4-Dichlorobenzene	<10	<11	<10	<9.8	<10	<10
2,4,6-Trichlorophenol	<10	<11	<10	<9.8	<10	<10
2,4-Dichlorophenol	<10	<11	<10	<9.8	<10	<10
2,4-Dimethyl phenol	<10	<11	<10	<9.8	<10	<10
2,4-Dinitrophenol	<51	<53	<51	<49	<51	<50
2,4-Dinitrotoluene	<10	<11	<10	<9.8	<10	<10
2,6-Dinitrotoluene	<10	<11	<10	<9.8	<10	<10
2-Chloronaphthalene	<10	<11	<10	<9.8	<10	<10
2-Chlorophenol	<10	<11	<10	<9.8	<10	<10
2-Nitrophenol	<10	<11	<10	<9.8	<10	<10
3,3'-Dichlorobenzidine	<51	<53	<51	<49	<51	<50
4,6-Dinitro-2-methylphenol	<51	<53	<51	<49	<51	<50
4-Bromophenyl phenyl ether	<10	<11	<10	<9.8	<10	<10
4-Chloro-3-methylphenol	<10	<11	<10	<9.8	<10	<10
4-Chlorophenyl phenyl ether	<10	<11	<10	<9.8	<10	<10
4-Nitrophenol	<51	<53	<51	<49	<51	<50
Acenaphthene	<10	<11	<10	<9.8	<10	<10
Acenaphthylene	<10	<11	<10	<9.8	<10	<10
Anthracene	<10	<11	<10	<9.8	<10	<10
Benzidine	<100	<110	<100	<98	<100	<100
Benzo(a)anthracene	<10	<11	<10	<9.8	<10	<10
Benzo(a)pyrene	<10	<11	<10	<9.8	<10	<10
Benzo(b)fluoranthene	<10	<11	<10	<9.8	<10	<10
Benzo(g,h,i)perylene	<10	<11	<10	<9.8	<10	<10
Benzo(k)fluoranthene	<10	<11	<10	<9.8	<10	<10
Benzyl butyl phthalate	<10	<11	<10	<9.8	<10	<10
bis(2-chloroethoxy) Methane	<10	<11	<10	<9.8	<10	<10
bis(2-chloroethyl) Ether	<10	<11	<10	<9.8	<10	<10

10/29/09

Table 24 EPA 625 SVOCs - Water.xls

TABLE 24

**EPA 625 SEMI-VOLATILE ORGANIC COMPOUNDS WATER SAMPLE DATA SUMMARY
 DEMONSTRATION TESTING AND FULL-SCALE OPERATION OF THE BIOGENESIS SEDIMENT DECONTAMINATION PROCESS
 KEASBEY, NEW JERSEY
 (Page 10 of 16)**

Field Sample Identification	WW-160206-1200	WW-170206-0900	WW-220206-1500	CARBON FILTERS- PRIMARY	WW-280206-0900	WW-010306-0900
Date Collected Matrix	2/16/06 Water	2/17/06 Water	2/22/06 Water	2/24/06 Water	2/28/06 Water	3/1/06 Water
Analyte/Methods (Units)						
Semi-Volatile Organic Compounds/EPA625 (µg/l) (continued)						
bis(2-chloroisopropyl) Ether	<10	<11	<10	<9.8	<10	<10
bis(2-ethylhexyl) Phthalate	<10	<11	<10	<9.8	<10	<10
Chrysene	<10	<11	<10	<9.8	<10	<10
Di-n-butyl phthalate	<10	<11	<10	<9.8	<10	<10
Di-n-octylphthalate	<10	<11	<10	<9.8	<10	<10
Dibenz(a,h)anthracene	<10	<11	<10	<9.8	<10	<10
Diethyl Phthalate	<10	<11	<10	<9.8	<10	<10
Dimethyl phthalate	<10	<11	<10	<9.8	<10	<10
Fluoranthene	<10	<11	<10	<9.8	<10	<10
Fluorene	<10	<11	<10	<9.8	<10	<10
Hexachlorobenzene	<10	<11	<10	<9.8	<10	<10
Hexachlorobutadiene	<10	<11	<10	<9.8	<10	<10
Hexachlorocyclopentadiene	<10	<11	<10	<9.8	<10	<10
Hexachloroethane	<10	<11	<10	<9.8	<10	<10
Indeno(1,2,3-c,d)Pyrene	<10	<11	<10	<9.8	<10	<10
Isophorone	<10	<11	<10	<9.8	<10	<10
n-Nitroso-di-n-propylamine	<10	<11	<10	<9.8	<10	<10
n-Nitrosodimethylamine	<10	<11	<10	<9.8	<10	<10
n-Nitrosodiphenylamine	<10	<11	<10	<9.8	<10	<10
Naphthalene	<10	<11	<10	<9.8	<10	<10
Nitrobenzene	<10	<11	<10	<9.8	<10	<10
Pentachlorophenol	<51	<53	<51	<49	<51	<50
Phenanthrene	<10	<11	<10	<9.8	<10	<10
Phenol	<10	<11	<10	<9.8	<10	<10
Pyrene	<10	<11	<10	<9.8	<10	<10

µg/l micrograms per liter.

Bold Bolded result indicates positively identified compound.

D Sample dilution required for analysis; reported values reflect the dilution.

T Analyte was positively identified but the reported concentration is estimated; reported concentration is less than the reporting limit, but greater than the method detection limit.

TABLE 24

EPA 625 SEMI-VOLATILE ORGANIC COMPOUNDS WATER SAMPLE DATA SUMMARY
DEMONSTRATION TESTING AND FULL-SCALE OPERATION OF THE BIOGENESIS SEDIMENT DECONTAMINATION PROCESS
KEASBEY, NEW JERSEY
 (Page 11 of 16)

Field Sample Identification	WW-010306-0900	WW-030306-1100	WW-140306-1600	WW-150306-1700	WW-1600306-1700	WW-170306-1400
Date Collected Matrix	3/2/06 Water	3/3/06 Water	3/14/06 Water	3/15/06 Water	3/16/06 Water	3/17/06 Water
Analyte/Methods (Units)						
Semi-Volatile Organic Compounds/EPA625 (µg/l)						
1,2,4-Trichlorobenzene	<10	<10	<11	<10	<11	<11
1,2-Dichlorobenzene	<10	<10	<11	<10	<11	<11
1,2-Diphenylhydrazine	<10	<10	<11	<10	<11	<11
1,3-Dichlorobenzene	<10	<10	<11	<10	<11	<11
1,4-Dichlorobenzene	<10	<10	<11	<10	<11	<11
2,4,6-Trichlorophenol	<10	<10	<11	<10	<11	<11
2,4-Dichlorophenol	<10	<10	<11	<10	<11	<11
2,4-Dimethyl phenol	<10	<10	<11	<10	<11	<11
2,4-Dinitrophenol	<52	<51	<53	<52	<54	<53
2,4-Dinitrotoluene	<10	<10	<11	<10	<11	<11
2,6-Dinitrotoluene	<10	<10	<11	<10	<11	<11
2-Chloronaphthalene	<10	<10	<11	<10	<11	<11
2-Chlorophenol	<10	<10	<11	<10	<11	<11
2-Nitrophenol	<10	<10	<11	<10	<11	<11
3,3'-Dichlorobenzidine	<52	<51	<53	<52	<54	<53
4,6-Dinitro-2-methylphenol	<52	<51	<53	<52	<54	<53
4-Bromophenyl phenyl ether	<10	<10	<11	<10	<11	<11
4-Chloro-3-methylphenol	<10	<10	<11	<10	<11	<11
4-Chlorophenyl phenyl ether	<10	<10	<11	<10	<11	<11
4-Nitrophenol	<52	<51	<53	<52	<54	<53
Acenaphthene	<10	<10	<11	<10	<11	<11
Acenaphthylene	<10	<10	<11	<10	<11	<11
Anthracene	<10	<10	<11	<10	<11	<11
Benzidine	<100	<100	<110	<100	<110	<110
Benzo(a)anthracene	<10	<10	<11	<10	<11	<11
Benzo(a)pyrene	<10	<10	<11	<10	<11	<11
Benzo(b)fluoranthene	<10	<10	<11	<10	<11	<11
Benzo(g,h,i)perylene	<10	<10	<11	<10	<11	<11
Benzo(k)fluoranthene	<10	<10	<11	<10	<11	<11
Benzyl butyl phthalate	<10	<10	3.2 T	1.1 T	<11	<11
bis(2-chloroethoxy) Methane	<10	<10	<11	<10	<11	<11
bis(2-chloroethyl) Ether	<10	<10	<11	<10	<11	<11

10/29/09

Table 24 EPA 625 SVOCs - Water.xls

TABLE 24

EPA 625 SEMI-VOLATILE ORGANIC COMPOUNDS WATER SAMPLE DATA SUMMARY
DEMONSTRATION TESTING AND FULL-SCALE OPERATION OF THE BIOGENESIS SEDIMENT DECONTAMINATION PROCESS
KEASBEY, NEW JERSEY
 (Page 12 of 16)

Field Sample Identification	WW-010306-0900	WW-030306-1100	WW-140306-1600	WW-150306-1700	WW-1600306-1700	WW-170306-1400
Date Collected	3/2/06	3/3/06	3/14/06	3/15/06	3/16/06	3/17/06
Matrix	Water	Water	Water	Water	Water	Water
Analyte/Methods (Units)						
Semi-Volatile Organic Compounds/EPA625 (µg/l) (continued)						
bis(2-chloroisopropyl) Ether	<10	<10	<11	<10	<11	<11
bis(2-ethylhexyl) Phthalate	<10	<10	1.2 T	<10	<11	<11
Chrysene	<10	<10	<11	<10	<11	<11
Di-n-butyl phthalate	<10	<10	1.2 T	<10	<11	<11
Di-n-octylphthalate	<10	<10	<11	<10	<11	<11
Dibenz(a,h)anthracene	<10	<10	<11	<10	<11	<11
Diethyl Phthalate	<10	<10	<11	<10	<11	<11
Dimethyl phthalate	<10	<10	<11	<10	<11	<11
Fluoranthene	<10	<10	<11	<10	<11	<11
Fluorene	<10	<10	<11	<10	<11	<11
Hexachlorobenzene	<10	<10	<11	<10	<11	<11
Hexachlorobutadiene	<10	<10	<11	<10	<11	<11
Hexachlorocyclopentadiene	<10	<10	<11	<10	<11	<11
Hexachloroethane	<10	<10	<11	<10	<11	<11
Indeno(1,2,3-c,d)Pyrene	<10	<10	<11	<10	<11	<11
Isophorone	<10	<10	<11	<10	<11	<11
n-Nitroso-di-n-propylamine	<10	<10	<11	<10	<11	<11
n-Nitrosodimethylamine	<10	<10	<11	<10	<11	<11
n-Nitrosodiphenylamine	<10	<10	<11	<10	<11	<11
Naphthalene	<10	1.9 T	<11	<10	<11	<11
Nitrobenzene	<10	<10	<11	<10	<11	<11
Pentachlorophenol	<52	<51	<53	<52	<54	<53
Phenanthrene	<10	<10	<11	<10	<11	<11
Phenol	<10	<10	<11	<10	<11	<11
Pyrene	<10	<10	<11	<10	<11	<11

µg/l micrograms per liter.

Bold Bolded result indicates positively identified compound.

D Sample dilution required for analysis; reported values reflect the dilution.

T Analyte was positively identified but the reported concentration is estimated; reported concentration is less than the reporting limit, but greater than the method detection limit.

TABLE 24

EPA 625 SEMI-VOLATILE ORGANIC COMPOUNDS WATER SAMPLE DATA SUMMARY
DEMONSTRATION TESTING AND FULL-SCALE OPERATION OF THE BIOGENESIS SEDIMENT DECONTAMINATION PROCESS
KEASBEY, NEW JERSEY
 (Page 13 of 16)

Field Sample Identification	WW-300306-1300	WW-070406-1530	WW-120406-1000	WW-200406-1400	WW-260406-1000	WW-040506-1100
Date Collected Matrix	3/30/06 Water	4/7/06 Water	4/12/06 Water	4/20/06 Water	4/26/06 Water	5/4/06 Water
Analyte/Methods (Units)						
Semi-Volatile Organic Compounds/EPA625 (µg/l)						
1,2,4-Trichlorobenzene	<10	<10	<10	<10	<20 D	<21 D
1,2-Dichlorobenzene	<10	<10	<10	<10	<20 D	<21 D
1,2-Diphenylhydrazine	<10	<10	<10	<10	<20 D	<21 D
1,3-Dichlorobenzene	<10	<10	<10	<10	<20 D	<21 D
1,4-Dichlorobenzene	<10	<10	<10	<10	<20 D	<21 D
2,4,6-Trichlorophenol	<10	<10	<10	<10	<20 D	<21 D
2,4-Dichlorophenol	<10	<10	<10	<10	<20 D	<21 D
2,4-Dimethyl phenol	<10	<10	<10	<10	<20 D	<21 D
2,4-Dinitrophenol	<52	<52	<50	<52	<100 D	<100 D
2,4-Dinitrotoluene	<10	<10	<10	<10	<20 D	<21 D
2,6-Dinitrotoluene	<10	<10	<10	<10	<20 D	<21 D
2-Chloronaphthalene	<10	<10	<10	<10	<20 D	<21 D
2-Chlorophenol	<10	<10	<10	<10	<20 D	<21 D
2-Nitrophenol	<10	<10	<10	<10	<20 D	<21 D
3,3'-Dichlorobenzidine	<52	<52	<50	<52	<100 D	<100 D
4,6-Dinitro-2-methylphenol	<52	<52	<50	<52	<100 D	<100 D
4-Bromophenyl phenyl ether	<10	<10	<10	<10	<20 D	<21 D
4-Chloro-3-methylphenol	<10	<10	<10	<10	<20 D	<21 D
4-Chlorophenyl phenyl ether	<10	<10	<10	<10	<20 D	<21 D
4-Nitrophenol	<52	<52	<50	<52	<100 D	<100 D
Acenaphthene	<10	<10	<10	<10	<20 D	<21 D
Acenaphthylene	<10	<10	<10	<10	<20 D	<21 D
Anthracene	<10	<10	<10	<10	<20 D	<21 D
Benzidine	<100	<100	<100	<100	<200 D	<210 D
Benzo(a)anthracene	<10	<10	<10	<10	<20 D	<21 D
Benzo(a)pyrene	<10	<10	<10	<10	<20 D	<21 D
Benzo(b)fluoranthene	<10	<10	<10	<10	<20 D	<21 D
Benzo(g,h,i)perylene	<10	<10	<10	<10	<20 D	<21 D
Benzo(k)fluoranthene	<10	<10	<10	<10	<20 D	<21 D
Benzyl butyl phthalate	<10	<10	2.7 T	<10	<20 D	<21 D
bis(2-chloroethoxy) Methane	<10	<10	<10	<10	<20 D	<21 D
bis(2-chloroethyl) Ether	<10	<10	<10	<10	<20 D	<21 D

10/29/09

Table 24 EPA 625 SVOCs - Water.xls

TABLE 24

EPA 625 SEMI-VOLATILE ORGANIC COMPOUNDS WATER SAMPLE DATA SUMMARY
DEMONSTRATION TESTING AND FULL-SCALE OPERATION OF THE BIOGENESIS SEDIMENT DECONTAMINATION PROCESS
KEASBEY, NEW JERSEY
 (Page 14 of 16)

Field Sample Identification	WW-300306-1300	WW-070406-1530	WW-120406-1000	WW-200406-1400	WW-260406-1000	WW-040506-1100
Date Collected	3/30/06	4/7/06	4/12/06	4/20/06	4/26/06	5/4/06
Matrix	Water	Water	Water	Water	Water	Water
Analyte/Methods (Units)						
Semi-Volatile Organic Compounds/EPA625 (µg/l) (continued)						
bis(2-chloroisopropyl) Ether	<10	<10	<10	<10	<20 D	<21 D
bis(2-ethylhexyl) Phthalate	<10	<10	<10	1.4 T	5.1 TD	<21 D
Chrysene	<10	<10	<10	<10	<20 D	<21 D
Di-n-butyl phthalate	<10	<10	<10	<10	<20 D	<21 D
Di-n-octylphthalate	<10	<10	<10	<10	<20 D	<21 D
Dibenz(a,h)anthracene	<10	<10	<10	<10	<20 D	<21 D
Diethyl Phthalate	<10	<10	<10	<10	<20 D	<21 D
Dimethyl phthalate	<10	<10	<10	<10	<20 D	<21 D
Fluoranthene	<10	<10	<10	<10	<20 D	<21 D
Fluorene	<10	<10	<10	<10	<20 D	<21 D
Hexachlorobenzene	<10	<10	<10	<10	<20 D	<21 D
Hexachlorobutadiene	<10	<10	<10	<10	<20 D	<21 D
Hexachlorocyclopentadiene	<10	<10	<50	<10	<20 D	<21 D
Hexachloroethane	<10	<10	<10	<10	<20 D	<21 D
Indeno(1,2,3-c,d)Pyrene	<10	<10	<10	<10	<20 D	<21 D
Isophorone	<10	<10	<10	<10	<20 D	<21 D
n-Nitroso-di-n-propylamine	<10	<10	<10	<10	<20 D	<21 D
n-Nitrosodimethylamine	<10	<10	<10	<10	<20 D	<21 D
n-Nitrosodiphenylamine	<10	<10	<10	<10	<20 D	<21 D
Naphthalene	<10	<10	1.5 T	<10	<20 D	<21 D
Nitrobenzene	<10	<10	<10	<10	6.7 TD	<21 D
Pentachlorophenol	<52	<52	<50	<52	<100 D	<100 D
Phenanthrene	<10	<10	<10	<10	<20 D	<21 D
Phenol	<10	<10	<10	<10	<20 D	<21 D
Pyrene	<10	<10	<10	<10	<20 D	<21 D

µg/l micrograms per liter.

Bold Bolded result indicates positively identified compound.

D Sample dilution required for analysis; reported values reflect the dilution.

T Analyte was positively identified but the reported concentration is estimated; reported concentration is less than the reporting limit, but greater than the method detection limit.

TABLE 24

**EPA 625 SEMI-VOLATILE ORGANIC COMPOUNDS WATER SAMPLE DATA SUMMARY
 DEMONSTRATION TESTING AND FULL-SCALE OPERATION OF THE BIOGENESIS SEDIMENT DECONTAMINATION PROCESS
 KEASBEY, NEW JERSEY
 (Page 15 of 16)**

Field Sample Identification	WW-120506-1100	WW-170506-1100
Date Collected	5/12/06	5/17/06
Matrix	Water	Water
Analyte/Methods (Units)		
Semi-Volatile Organic Compounds/EPA625 (µg/l)		
1,2,4-Trichlorobenzene	<100 D	<55 D
1,2-Dichlorobenzene	<100 D	<55 D
1,2-Diphenylhydrazine	<100 D	<55 D
1,3-Dichlorobenzene	<100 D	<55 D
1,4-Dichlorobenzene	<100 D	<55 D
2,4,6-Trichlorophenol	<100 D	<55 D
2,4-Dichlorophenol	<100 D	<55 D
2,4-Dimethyl phenol	<100 D	<55 D
2,4-Dinitrophenol	<520 D	<280 D
2,4-Dinitrotoluene	<100 D	<55 D
2,6-Dinitrotoluene	<100 D	<55 D
2-Chloronaphthalene	<100 D	<55 D
2-Chlorophenol	<100 D	<55 D
2-Nitrophenol	<100 D	<55 D
3,3'-Dichlorobenzidine	<520 D	<280 D
4,6-Dinitro-2-methylphenol	<520 D	<280 D
4-Bromophenyl phenyl ether	<100 D	<55 D
4-Chloro-3-methylphenol	<100 D	<55 D
4-Chlorophenyl phenyl ether	<100 D	<55 D
4-Nitrophenol	<520 D	<280 D
Acenaphthene	<100 D	<55 D
Acenaphthylene	<100 D	<55 D
Anthracene	<100 D	<55 D
Benzidine	<1000 D	<550 D
Benzo(a)anthracene	<100 D	<55 D
Benzo(a)pyrene	<100 D	<55 D
Benzo(b)fluoranthene	<100 D	<55 D
Benzo(g,h,i)perylene	<100 D	10 TD
Benzo(k)fluoranthene	<100 D	<55 D
Benzyl butyl phthalate	<100 D	<55 D
bis(2-chloroethoxy) Methane	<100 D	<55 D
bis(2-chloroethyl) Ether	<100 D	<55 D

TABLE 24

**EPA 625 SEMI-VOLATILE ORGANIC COMPOUNDS WATER SAMPLE DATA SUMMARY
 DEMONSTRATION TESTING AND FULL-SCALE OPERATION OF THE BIOGENESIS SEDIMENT DECONTAMINATION PROCESS
 KEASBEY, NEW JERSEY
 (Page 16 of 16)**

Field Sample Identification	WW-120506-1100	WW-170506-1100
Date Collected	5/12/06	5/17/06
Matrix	Water	Water
Analyte/Methods (Units)		
Semi-Volatile Organic Compounds/EPA625 (µg/l) (continued)		
bis(2-chloroisopropyl) Ether	<100 D	<55 D
bis(2-ethylhexyl) Phthalate	<100 D	20 TD
Chrysene	<100 D	<55 D
Di-n-butyl phthalate	<100 D	<55 D
Di-n-octylphthalate	<100 D	13 TD
Dibenz(a,h)anthracene	<100 D	<55 D
Diethyl Phthalate	<100 D	<55 D
Dimethyl phthalate	<100 D	<55 D
Fluoranthene	<100 D	<55 D
Fluorene	<100 D	<55 D
Hexachlorobenzene	<100 D	<55 D
Hexachlorobutadiene	<100 D	<55 D
Hexachlorocyclopentadiene	<100 D	<55 D
Hexachloroethane	<100 D	<55 D
Indeno(1,2,3-c,d)Pyrene	<100 D	<55 D
Isophorone	<100 D	<55 D
n-Nitroso-di-n-propylamine	<100 D	<55 D
n-Nitrosodimethylamine	<100 D	<55 D
n-Nitrosodiphenylamine	<100 D	<55 D
Naphthalene	<100 D	<55 D
Nitrobenzene	<100 D	<55 D
Pentachlorophenol	<520 D	<280 D
Phenanthrene	<100 D	<55 D
Phenol	<100 D	<55 D
Pyrene	<100 D	<55 D

µg/l micrograms per liter.

Bold Bolded result indicates positively identified compound.

D Sample dilution required for analysis; reported values reflect the dilution.

T Analyte was positively identified but the reported concentration is estimated; reported concentration is less than the reporting limit, but greater than the method detection limit.

TABLE 25

SW8270C SEMI-VOLATILE ORGANIC COMPOUNDS WATER SAMPLE DATA SUMMARY
DEMONSTRATION TESTING AND FULL-SCALE OPERATION OF THE BIOGENESIS SEDIMENT DECONTAMINATION PROCESS
KEASBEY, NEW JERSEY
(Page 1 of 1)

Field Sample Identification	WW-211205-1600	WW-271205-1600	WW-291205-1120
Date Collected	12/21/05	12/27/05	12/29/05
Matrix	Water	Water	Water
Analyte/Methods (Units)			
Semi-Volatile Organic Compounds/SW870C (µg/l)			
1,4-Dichlorobenzene	<10	<10	<10
2,4,5-Trichlorophenol	<10	<10	<10
2,4,6-Trichlorophenol	<10	<10	<10
2,4-Dinitrotoluene	<10	<10	<10
2-Methylphenol	<10	<10	<10
Acenaphthene	<10	<10	<10
Acenaphthylene	<10	<10	<10
Anthracene	<10	<10	<10
Benzo(a)anthracene	<10	<10	<10
Benzo(a)pyrene	<10	<10	<10
Benzo(b)fluoranthene	<10	<10	<10
Benzo(g,h,i)perylene	<10	<10	<10
Benzo(k)fluoranthene	<10	<10	<10
Chrysene	<10	<10	<10
Cresols, m	<20	<21	<21
Dibenz(a,h)anthracene	<10	<10	<10
Fluoranthene	<10	<10	<10
Fluorene	<10	<10	<10
Hexachlorobenzene	<10	<10	<10
Hexachlorobutadiene	<10	<10	<10
Hexachloroethane	<10	<10	<10
Indeno(1,2,3-c,d)Pyrene	<10	<10	<10
Naphthalene	<10	<10	<10
Nitrobenzene	<10	<10	<10
Pentachlorophenol	<50	<52	<52
Pyrene	<10	<10	<10

µg/l micrograms per liter.

TABLE 26

POLYNUCLEAR AROMATIC HYDROCARBON COMPOUNDS WATER SAMPLE DATA SUMMARY
DEMONSTRATION TESTING AND FULL-SCALE OPERATION OF THE BIOGENESIS SEDIMENT DECONTAMINATION PROCESS
KEASBEY, NEW JERSEY
(Page 1 of 1)

Field Sample Identification Date Collected Matrix	WW-211205-1600 12/21/05 Water	WW-271205-1600 12/27/05 Water	WW-291205-1120 12/29/05 Water
Analyte/Methods (Units)			
Polynuclear Aromatic Hydrocarbons/SW8270C-SIM (µg/l)			
Acenaphthene	<0.2	0.042 T	<0.21
Acenaphthylene	<0.2	<0.21	<0.21
Anthracene	<0.2	<0.21	<0.21
Benzo(a)anthracene	<0.2	0.032 T	0.029 T
Benzo(a)pyrene	<0.2	<0.21	<0.21
Benzo(b)fluoranthene	<0.2	<0.21	<0.21
Benzo(g,h,i)perylene	<0.2	<0.21	<0.21
Benzo(k)fluoranthene	<0.2	<0.21	<0.21
Chrysene	<0.2	<0.21	<0.21
Dibenz(a,h)anthracene	<0.2	<0.21	<0.21
Fluoranthene	<0.2	0.034 T	<0.21
Fluorene	0.037 T	0.048 T	<0.21
Indeno(1,2,3-c,d)Pyrene	<0.2	<0.21	<0.21
Naphthalene	<0.2	0.081 T	<0.21
Phenanthrene	0.12 T	0.13 T	0.098 T
Pyrene	<0.2	0.044 T	0.025 T

µg/l micrograms per liter.

Bold Bolded result indicates positively identified compound.

T Analyte was positively identified but the reported concentration is estimated; reported concentration is less than the reporting limit, but greater than the method detection limit.

SIM Selective ion monitoring

TABLE 27

EPA 608 PESTICIDES/POLYCHLORINATED BIPHENYLS WATER SAMPLE DATA SUMMARY
DEMONSTRATION TESTING AND FULL-SCALE OPERATION OF THE BIOGENESIS SEDIMENT DECONTAMINATION PROCESS
KEASBEY, NEW JERSEY
 (Page 1 of 16)

Field Sample Identification	WW2-221205-1430	WW-030106-1200	WW-040106-1545	WW-050106-1515	WW-060106-1530	WW-090106-1530
Date Collected Matrix	12/22/05 Water	1/3/06 Water	1/4/06 Water	1/5/06 Water	1/6/06 Water	1/9/06 Water
Analyte/Methods (Units)						
Pesticides/EPA608 (µg/l)						
Aldrin	<0.13 D	<0.01	<0.01	<0.01	<0.01	<0.01
alpha BHC	<0.13 D	<0.01	<0.01	<0.01	<0.01	<0.01
alpha Endosulfan	<0.13 D	<0.01	<0.01	<0.01	<0.01	<0.01
alpha-Chlordane	<0.13 D	<0.01	<0.01	<0.01	<0.01	<0.01
beta BHC	<0.13 D	<0.01	<0.01	<0.01	<0.01	<0.01
beta Endosulfan	<0.13 D	<0.01	<0.01	<0.01	<0.01	<0.01
Chlordane	<1.3 D	<0.1	<0.1	<0.1	<0.1	<0.1
delta BHC	<0.13 D	<0.01	<0.01	<0.01	<0.01	<0.01
Dieldrin	<0.13 D	<0.01	<0.01	0.0038 T	<0.01	<0.01
Endosulfan sulfate	<0.13 D	<0.01	<0.01	<0.01	<0.01	<0.01
Endrin	<0.13 D	<0.01	<0.01	<0.01	<0.01	<0.01
Endrin aldehyde	<0.13 D	<0.01	<0.01	<0.01	<0.01	<0.01
Endrin ketone	<0.13 D	<0.01	<0.01	<0.01	<0.01	<0.01
gamma BHC (Lindane)	<0.13 D	<0.01	<0.01	<0.01	<0.01	<0.01
gamma-Chlordane	<0.13 D	<0.01	<0.01	<0.01	<0.01	<0.01
Heptachlor	<0.13 D	<0.01	<0.01	<0.01	<0.01	<0.01
Heptachlor epoxide	<0.13 D	<0.01	<0.01	<0.01	<0.01	<0.01
Methoxychlor	<0.25 D	<0.02	<0.02	<0.02	<0.02	<0.02
p,p'-DDD	<0.13 D	<0.01	<0.01	<0.01	<0.01	<0.01
p,p'-DDE	<0.13 D	<0.01	<0.01	<0.01	<0.01	<0.01
p,p'-DDT	<0.13 D	<0.01	<0.01	<0.01	<0.01	<0.01
Toxaphene	<5.1 D	<0.4	<0.4	<0.4	<0.4	<0.4

TABLE 27

**EPA 608 PESTICIDES/POLYCHLORINATED BIPHENYLS WATER SAMPLE DATA SUMMARY
 DEMONSTRATION TESTING AND FULL-SCALE OPERATION OF THE BIOGENESIS SEDIMENT DECONTAMINATION PROCESS
 KEASBEY, NEW JERSEY
 (Page 2 of 16)**

Field Sample Identification	WW2-221205-1430	WW-030106-1200	WW-040106-1545	WW-050106-1515	WW-060106-1530	WW-090106-1530
Date Collected	12/22/05	1/3/06	1/4/06	1/5/06	1/6/06	1/9/06
Matrix	Water	Water	Water	Water	Water	Water
Analyte/Methods (Units)						
Polychlorinated Biphenyls/EPA608 (µg/l)						
PCB-1016 (Arochlor 1016)	<2.5 D	<0.2	<0.2	<0.2	<0.2	<0.2
PCB-1221 (Arochlor 1221)	<2.5 D	<0.2	<0.2	<0.2	<0.2	<0.2
PCB-1232 (Arochlor 1232)	<2.5 D	<0.2	<0.2	<0.2	<0.2	<0.2
PCB-1242 (Arochlor 1242)	<2.5 D	<0.2	<0.2	<0.2	<0.2	<0.2
PCB-1248 (Arochlor 1248)	<2.5 D	<0.2	<0.2	<0.2	<0.2	<0.2
PCB-1254 (Arochlor 1254)	<2.5 D	<0.2	<0.2	<0.2	<0.2	<0.2
PCB-1260 (Arochlor 1260)	<2.5 D	<0.2	<0.2	<0.2	<0.2	<0.2

µg/l micrograms per liter.

Bold Bolded result indicates positively identified compound.

- Not analyzed.

D Sample dilution required for analysis; reported values reflect the dilution.

J Data are estimated due to associated quality control data.

T Analyte was positively identified but the reported concentration is estimated; reported concentration is less than the reporting limit, but greater than the method detection limit.

TABLE 27

EPA 608 PESTICIDES/POLYCHLORINATED BIPHENYLS WATER SAMPLE DATA SUMMARY
DEMONSTRATION TESTING AND FULL-SCALE OPERATION OF THE BIOGENESIS SEDIMENT DECONTAMINATION PROCESS
KEASBEY, NEW JERSEY
 (Page 3 of 16)

Field Sample Identification	WW-100106-1603	WW-110106-1632	WW-120106-1603	WW-130106-1430	WW-170106-1400	WW-180106-1600
Date Collected Matrix	1/10/06 Water	1/11/06 Water	1/12/06 Water	1/13/06 Water	1/17/06 Water	1/18/06 Water
Analyte/Methods (Units)						
Pesticides/EPA608 (µg/l)						
Aldrin	<0.01	<0.01	<0.01	<0.01	<0.01	<0.01
alpha BHC	<0.01	<0.01	<0.01	<0.01	<0.01	<0.01
alpha Endosulfan	<0.01	<0.01	<0.01	<0.01	<0.01	<0.01
alpha-Chlordane	<0.01	<0.01	<0.01	<0.01	<0.01	<0.01
beta BHC	<0.01	<0.01	<0.01	<0.01	<0.01	<0.01
beta Endosulfan	<0.01	<0.01	<0.01	<0.01	<0.01	<0.01
Chlordane	<0.1	<0.1	<0.1	<0.1	<0.1	<0.1
delta BHC	<0.01	<0.01	<0.01	<0.01	<0.01	<0.01
Dieldrin	<0.01	<0.01	<0.01	<0.01	<0.01	<0.01
Endosulfan sulfate	<0.01	<0.01	<0.01	<0.01	<0.01	<0.01
Endrin	<0.01	<0.01	<0.01	<0.01	<0.01	<0.01
Endrin aldehyde	<0.01	<0.01	<0.01	<0.01	<0.01	<0.01
Endrin ketone	<0.01	<0.01	-	-	-	-
gamma BHC (Lindane)	<0.01	<0.01	<0.01	<0.01	<0.01	<0.01
gamma-Chlordane	<0.01	<0.01	<0.01	<0.01	<0.01	<0.01
Heptachlor	<0.01	<0.01	<0.01	<0.01	<0.01	<0.01
Heptachlor epoxide	<0.01	<0.01	<0.01	<0.01	<0.01	<0.01
Methoxychlor	<0.02	<0.02	-	-	-	-
p,p'-DDD	<0.01	<0.01	<0.01	<0.01	<0.01	<0.01
p,p'-DDE	<0.01	<0.01	<0.01	<0.01	<0.01	<0.01
p,p'-DDT	<0.01	<0.01	<0.01	<0.01	<0.01	<0.01
Toxaphene	<0.4	<0.4	<0.41	<0.4	<0.41	<0.41

TABLE 27

EPA 608 PESTICIDES/POLYCHLORINATED BIPHENYLS WATER SAMPLE DATA SUMMARY
DEMONSTRATION TESTING AND FULL-SCALE OPERATION OF THE BIOGENESIS SEDIMENT DECONTAMINATION PROCESS
KEASBEY, NEW JERSEY
 (Page 4 of 16)

Field Sample Identification	WW-100106-1603	WW-110106-1632	WW-120106-1603	WW-130106-1430	WW-170106-1400	WW-180106-1600
Date Collected	1/10/06	1/11/06	1/12/06	1/13/06	1/17/06	1/18/06
Matrix	Water	Water	Water	Water	Water	Water
Analyte/Methods (Units)						
Polychlorinated Biphenyls/EPA608 (µg/l)						
PCB-1016 (Arochlor 1016)	<0.2	<0.2	<0.2	<0.2	<0.21	<0.21
PCB-1221 (Arochlor 1221)	<0.2	<0.2	<0.2	<0.2	<0.21	<0.21
PCB-1232 (Arochlor 1232)	<0.2	<0.2	<0.2	<0.2	<0.21	<0.21
PCB-1242 (Arochlor 1242)	<0.2	<0.2	<0.2	<0.2	<0.21	<0.21
PCB-1248 (Arochlor 1248)	<0.2	<0.2	<0.2	<0.2	<0.21	<0.21
PCB-1254 (Arochlor 1254)	<0.2	<0.2	<0.2	<0.2	<0.21	<0.21
PCB-1260 (Arochlor 1260)	<0.2	<0.2	<0.2	<0.2	<0.21	<0.21

µg/l micrograms per liter.

Bold Bolded result indicates positively identified compound.

- Not analyzed.

D Sample dilution required for analysis; reported values reflect the dilution.

J Data are estimated due to associated quality control data.

T Analyte was positively identified but the reported concentration is estimated; reported concentration is less than the reporting limit, but greater than the method detection limit.

TABLE 27

EPA 608 PESTICIDES/POLYCHLORINATED BIPHENYLS WATER SAMPLE DATA SUMMARY
DEMONSTRATION TESTING AND FULL-SCALE OPERATION OF THE BIOGENESIS SEDIMENT DECONTAMINATION PROCESS
KEASBEY, NEW JERSEY
 (Page 5 of 16)

Field Sample Identification	WW-190106-1603	WW-200106-1530	WW-230106-1630	WW-240106-1631	WW-250106-1530	WW-300106-1703
Date Collected Matrix	1/19/06 Water	1/20/06 Water	1/23/06 Water	1/24/06 Water	1/25/06 Water	1/30/06 Water
Analyte/Methods (Units)						
Pesticides/EPA608 (µg/l)						
Aldrin	<0.01	<0.01	<0.01	<0.01	<0.01	<0.01
alpha BHC	<0.01	<0.01	<0.01	<0.01	<0.01	<0.01
alpha Endosulfan	<0.01	<0.01	<0.01	<0.01	<0.01	<0.01
alpha-Chlordane	-	-	-	-	-	-
beta BHC	<0.01	<0.01	<0.01	<0.01	<0.01	<0.01
beta Endosulfan	<0.01	<0.01	<0.01	<0.01	<0.01	<0.01
Chlordane	<0.1	<0.1	<0.1	<0.1	<0.1	<0.1
delta BHC	<0.01	<0.01	<0.01	<0.01	<0.01	<0.01
Dieldrin	<0.01	<0.01	<0.01	<0.01	<0.01	<0.01
Endosulfan sulfate	<0.01	<0.01	<0.01	<0.01	<0.01	<0.01
Endrin	<0.01	<0.01	<0.01	<0.01	<0.01	<0.01
Endrin aldehyde	<0.01	<0.01	<0.01	<0.01	<0.01	<0.01
Endrin ketone	-	-	-	-	-	-
gamma BHC (Lindane)	<0.01	<0.01	<0.01	<0.01	<0.01	<0.01
gamma-Chlordane	-	-	-	-	-	-
Heptachlor	<0.01	<0.01	<0.01	<0.01	<0.01	<0.01
Heptachlor epoxide	<0.01	<0.01	<0.01	<0.01	<0.01	<0.01
Methoxychlor	-	-	-	-	-	-
p,p'-DDD	<0.01	<0.01	<0.01	<0.01	<0.01	<0.01
p,p'-DDE	<0.01	<0.01	<0.01	<0.01	<0.01	<0.01
p,p'-DDT	<0.01	<0.01	<0.01	<0.01	<0.01	<0.01
Toxaphene	<0.41	<0.41	<0.41	<0.41	<0.41	<0.41

TABLE 27

EPA 608 PESTICIDES/POLYCHLORINATED BIPHENYLS WATER SAMPLE DATA SUMMARY
DEMONSTRATION TESTING AND FULL-SCALE OPERATION OF THE BIOGENESIS SEDIMENT DECONTAMINATION PROCESS
KEASBEY, NEW JERSEY
 (Page 6 of 16)

Field Sample Identification	WW-190106-1603	WW-200106-1530	WW-230106-1630	WW-240106-1631	WW-250106-1530	WW-300106-1703
Date Collected	1/19/06	1/20/06	1/23/06	1/24/06	1/25/06	1/30/06
Matrix	Water	Water	Water	Water	Water	Water
Analyte/Methods (Units)						
Polychlorinated Biphenyls/EPA608 (µg/l)						
PCB-1016 (Arochlor 1016)	<0.2	<0.2	<0.2	<0.2	<0.2	<0.2
PCB-1221 (Arochlor 1221)	<0.2	<0.2	<0.2	<0.2	<0.2	<0.2
PCB-1232 (Arochlor 1232)	<0.2	<0.2	<0.2	<0.2	<0.2	<0.2
PCB-1242 (Arochlor 1242)	<0.2	<0.2	<0.2	<0.2	<0.2	<0.2
PCB-1248 (Arochlor 1248)	<0.2	<0.2	<0.2	<0.2	<0.2	<0.2
PCB-1254 (Arochlor 1254)	<0.2	<0.2	<0.2	<0.2	<0.2	<0.2
PCB-1260 (Arochlor 1260)	<0.2	<0.2	<0.2	<0.2	<0.2	<0.2

µg/l micrograms per liter.

Bold Bolded result indicates positively identified compound.

- Not analyzed.

D Sample dilution required for analysis; reported values reflect the dilution.

J Data are estimated due to associated quality control data.

T Analyte was positively identified but the reported concentration is estimated; reported concentration is less than the reporting limit, but greater than the method detection limit.

TABLE 27

EPA 608 PESTICIDES/POLYCHLORINATED BIPHENYLS WATER SAMPLE DATA SUMMARY
DEMONSTRATION TESTING AND FULL-SCALE OPERATION OF THE BIOGENESIS SEDIMENT DECONTAMINATION PROCESS
KEASBEY, NEW JERSEY
 (Page 7 of 16)

Field Sample Identification	WW-310106-1703	WW-010206-1603	WW-020206-1803	WW-030206-1203	WW-070206-0930	WW-080206-0930
Date Collected	1/31/06	2/1/06	2/2/06	2/3/06	2/7/06	2/8/06
Matrix	Water	Water	Water	Water	Water	Water
Analyte/Methods (Units)						
Pesticides/EPA608 (µg/l)						
Aldrin	<0.01	<0.01	<0.01	<0.01	<0.01	<0.01
alpha BHC	<0.01	<0.01	<0.01	<0.01	<0.01	<0.01
alpha Endosulfan	<0.01	<0.01	<0.01	<0.01	<0.01	<0.01
alpha-Chlordane	-	-	-	-	-	-
beta BHC	<0.01	<0.01	<0.01	<0.01	<0.01	<0.01
beta Endosulfan	<0.01	<0.01	<0.01	<0.01	<0.01	<0.01
Chlordane	<0.1	<0.1	<0.1	<0.1	<0.1	<0.1
delta BHC	<0.01	<0.01	<0.01	<0.01	<0.01	<0.01
Dieldrin	<0.01	<0.01	<0.01	<0.01	<0.01	<0.01
Endosulfan sulfate	<0.01	<0.01	<0.01	<0.01	<0.01	<0.01
Endrin	<0.01	<0.01	<0.01	<0.01	<0.01	<0.01
Endrin aldehyde	<0.01	<0.01	<0.01	<0.01	<0.01	<0.01
Endrin ketone	-	-	-	-	-	-
gamma BHC (Lindane)	<0.01	<0.01	<0.01	<0.01	<0.01	<0.01
gamma-Chlordane	-	-	-	-	-	-
Heptachlor	<0.01	<0.01	<0.01	0.0053 T	<0.01	<0.01
Heptachlor epoxide	<0.01	<0.01	<0.01	<0.01	<0.01	<0.01
Methoxychlor	-	-	-	-	-	-
p,p'-DDD	<0.01	<0.01	<0.01	0.0037 T	<0.01	<0.01
p,p'-DDE	<0.01	<0.01	<0.01	<0.01	<0.01	<0.01
p,p'-DDT	<0.01	<0.01	<0.01	<0.01	<0.01	<0.01
Toxaphene	<0.41	<0.41	<0.41	<0.4	<0.41	<0.41

TABLE 27

EPA 608 PESTICIDES/POLYCHLORINATED BIPHENYLS WATER SAMPLE DATA SUMMARY
DEMONSTRATION TESTING AND FULL-SCALE OPERATION OF THE BIOGENESIS SEDIMENT DECONTAMINATION PROCESS
KEASBEY, NEW JERSEY
 (Page 8 of 16)

Field Sample Identification	WW-310106-1703	WW-010206-1603	WW-020206-1803	WW-030206-1203	WW-070206-0930	WW-080206-0930
Date Collected	1/31/06	2/1/06	2/2/06	2/3/06	2/7/06	2/8/06
Matrix	Water	Water	Water	Water	Water	Water
Analyte/Methods (Units)						
Polychlorinated Biphenyls/EPA608 (µg/l)						
PCB-1016 (Arochlor 1016)	<0.2	<0.2	<0.2	<0.2	<0.2	<0.2
PCB-1221 (Arochlor 1221)	<0.2	<0.2	<0.2	<0.2	<0.2	<0.2
PCB-1232 (Arochlor 1232)	<0.2	<0.2	<0.2	<0.2	<0.2	<0.2
PCB-1242 (Arochlor 1242)	<0.2	<0.2	<0.2	<0.2	<0.2	<0.2
PCB-1248 (Arochlor 1248)	<0.2	<0.2	<0.2	<0.2	<0.2	<0.2
PCB-1254 (Arochlor 1254)	<0.2	<0.2	<0.2	<0.2	<0.2	<0.2
PCB-1260 (Arochlor 1260)	<0.2	<0.2	<0.2	<0.2	<0.2	<0.2

µg/l micrograms per liter.

Bold Bolded result indicates positively identified compound.

- Not analyzed.

D Sample dilution required for analysis; reported values reflect the dilution.

J Data are estimated due to associated quality control data.

T Analyte was positively identified but the reported concentration is estimated; reported concentration is less than the reporting limit, but greater than the method detection limit.

TABLE 27

EPA 608 PESTICIDES/POLYCHLORINATED BIPHENYLS WATER SAMPLE DATA SUMMARY
DEMONSTRATION TESTING AND FULL-SCALE OPERATION OF THE BIOGENESIS SEDIMENT DECONTAMINATION PROCESS
KEASBEY, NEW JERSEY
 (Page 9 of 16)

Field Sample Identification	WW-090206-0930	WW-140206-0900	WW-160206-1200	WW-170206-0900	WW-220206-1500	CARBON FILTERS- PRIMARY
Date Collected Matrix	2/9/06 Water	2/14/06 Water	2/16/06 Water	2/17/06 Water	2/22/06 Water	2/24/06 Water
Analyte/Methods (Units)						
Pesticides/EPA608 (µg/l)						
Aldrin	<0.01	<0.01	<0.01	<0.01	<0.01	<0.01
alpha BHC	<0.01	<0.01	<0.01	<0.01	<0.01	<0.01
alpha Endosulfan	<0.01	<0.01	<0.01	<0.01	<0.01	0.0092 T
alpha-Chlordane	-	-	-	-	-	-
beta BHC	<0.01	<0.01	<0.01	<0.01	<0.01	<0.01
beta Endosulfan	<0.01	<0.01	<0.01	<0.01	<0.01	<0.01
Chlordane	<0.1	<0.1	<0.1	<0.1	<0.1	<0.1
delta BHC	<0.01	<0.01	<0.01	<0.01	<0.01	<0.01
Dieldrin	<0.01	<0.01	<0.01	<0.01	<0.01	<0.01
Endosulfan sulfate	<0.01	<0.01	<0.01	<0.01	<0.01	<0.01
Endrin	<0.01	<0.01	<0.01	<0.01	<0.01	<0.01
Endrin aldehyde	<0.01	<0.01	<0.01	<0.01	<0.01	<0.01
Endrin ketone	-	-	-	-	-	-
gamma BHC (Lindane)	<0.01	<0.01	<0.01	<0.01	<0.01	<0.01
gamma-Chlordane	-	-	-	-	-	-
Heptachlor	<0.01	<0.01	<0.01	<0.01	<0.01	<0.01
Heptachlor epoxide	<0.01	<0.01	<0.01	<0.01	<0.01	<0.01
Methoxychlor	-	-	-	-	-	-
p,p'-DDD	<0.01	<0.01	<0.01	<0.01	<0.01	<0.01
p,p'-DDE	<0.01	<0.01	<0.01	<0.01	<0.01	<0.01
p,p'-DDT	<0.01	<0.01	<0.01	<0.01	<0.01	<0.01
Toxaphene	<0.41	<0.41	<0.41	<0.4	<0.4	<0.41

TABLE 27

EPA 608 PESTICIDES/POLYCHLORINATED BIPHENYLS WATER SAMPLE DATA SUMMARY
DEMONSTRATION TESTING AND FULL-SCALE OPERATION OF THE BIOGENESIS SEDIMENT DECONTAMINATION PROCESS
KEASBEY, NEW JERSEY
(Page 10 of 16)

Field Sample Identification	WW-090206-0930	WW-140206-0900	WW-160206-1200	WW-170206-0900	WW-220206-1500	CARBON FILTERS- PRIMARY
Date Collected Matrix	2/9/06 Water	2/14/06 Water	2/16/06 Water	2/17/06 Water	2/22/06 Water	2/24/06 Water
Analyte/Methods (Units)						
Polychlorinated Biphenyls/EPA608 (µg/l)						
PCB-1016 (Arochlor 1016)	<0.2	<0.2	<0.2	<0.2	<0.2	<0.2
PCB-1221 (Arochlor 1221)	<0.2	<0.2	<0.2	<0.2	<0.2	<0.2
PCB-1232 (Arochlor 1232)	<0.2	<0.2	<0.2	<0.2	<0.2	<0.2
PCB-1242 (Arochlor 1242)	<0.2	<0.2	<0.2	<0.2	<0.2	<0.2
PCB-1248 (Arochlor 1248)	<0.2	<0.2	<0.2	<0.2	<0.2	<0.2
PCB-1254 (Arochlor 1254)	<0.2	<0.2	<0.2	<0.2	<0.2	<0.2
PCB-1260 (Arochlor 1260)	<0.2	<0.2	<0.2	<0.2	<0.2	<0.2

µg/l micrograms per liter.

Bold Bolded result indicates positively identified compound.

- Not analyzed.

D Sample dilution required for analysis; reported values reflect the dilution.

J Data are estimated due to associated quality control data.

T Analyte was positively identified but the reported concentration is estimated; reported concentration is less than the reporting limit, but greater than the method detection limit.

TABLE 27

EPA 608 PESTICIDES/POLYCHLORINATED BIPHENYLS WATER SAMPLE DATA SUMMARY
DEMONSTRATION TESTING AND FULL-SCALE OPERATION OF THE BIOGENESIS SEDIMENT DECONTAMINATION PROCESS
KEASBEY, NEW JERSEY
 (Page 11 of 16)

Field Sample Identification	WW-280206-0900	WW-010306-0900	WW-010306-0900	WW-030306-1100	WW-140306-1600	WW-150306-1700
Date Collected Matrix	2/28/06 Water	3/1/06 Water	3/2/06 Water	3/3/06 Water	3/14/06 Water	3/15/06 Water
Analyte/Methods (Units)						
Pesticides/EPA608 (µg/l)						
Aldrin	<0.01	<0.01	<0.01	<0.01	<0.01	<0.01
alpha BHC	<0.01	<0.01	<0.01	<0.01	<0.01	<0.01
alpha Endosulfan	<0.01	<0.01	<0.01	<0.01	<0.01	<0.01
alpha-Chlordane	-	-	-	-	-	-
beta BHC	<0.01	<0.01	<0.01	<0.01	<0.01	<0.01
beta Endosulfan	<0.01	<0.01	<0.01	<0.01	<0.01	<0.01
Chlordane	<0.1	<0.1	<0.1	<0.1	<0.1	<0.1
delta BHC	<0.01	<0.01	<0.01	<0.01	<0.01	<0.01
Dieldrin	<0.01	<0.01	<0.01	<0.01	<0.01	<0.01
Endosulfan sulfate	<0.01	<0.01	<0.01	<0.01	<0.01	<0.01
Endrin	<0.01	<0.01	<0.01	<0.01	<0.01	<0.01
Endrin aldehyde	<0.01	<0.01	<0.01	<0.01	<0.01	<0.01
Endrin ketone	-	-	-	-	-	-
gamma BHC (Lindane)	<0.01	<0.01	<0.01	<0.01	<0.01	<0.01
gamma-Chlordane	-	-	-	-	-	-
Heptachlor	<0.01	<0.01	<0.01	<0.01	<0.01	<0.01
Heptachlor epoxide	<0.01	<0.01	<0.01	<0.01	<0.01	<0.01
Methoxychlor	-	-	-	-	-	-
p,p'-DDD	<0.01	<0.01	<0.01	<0.01	<0.01	<0.01
p,p'-DDE	<0.01	<0.01	<0.01	<0.01	<0.01	<0.01
p,p'-DDT	<0.01	<0.01	<0.01	<0.01	<0.01	<0.01
Toxaphene	<0.41	<0.41	<0.41	<0.41	<0.42	<0.41

TABLE 27

EPA 608 PESTICIDES/POLYCHLORINATED BIPHENYLS WATER SAMPLE DATA SUMMARY
DEMONSTRATION TESTING AND FULL-SCALE OPERATION OF THE BIOGENESIS SEDIMENT DECONTAMINATION PROCESS
KEASBEY, NEW JERSEY
(Page 12 of 16)

Field Sample Identification	WW-280206-0900	WW-010306-0900	WW-010306-0900	WW-030306-1100	WW-140306-1600	WW-150306-1700
Date Collected	2/28/06	3/1/06	3/2/06	3/3/06	3/14/06	3/15/06
Matrix	Water	Water	Water	Water	Water	Water
Analyte/Methods (Units)						
Polychlorinated Biphenyls/EPA608 (µg/l)						
PCB-1016 (Arochlor 1016)	<0.2	<0.2	<0.2	<0.2	<0.21	<0.21
PCB-1221 (Arochlor 1221)	<0.2	<0.2	<0.2	<0.2	<0.21	<0.21
PCB-1232 (Arochlor 1232)	<0.2	<0.2	<0.2	<0.2	<0.21	<0.21
PCB-1242 (Arochlor 1242)	<0.2	<0.2	<0.2	<0.2	<0.21	<0.21
PCB-1248 (Arochlor 1248)	<0.2	<0.2	<0.2	<0.2	<0.21	<0.21
PCB-1254 (Arochlor 1254)	<0.2	<0.2	<0.2	<0.2	<0.21	<0.21
PCB-1260 (Arochlor 1260)	<0.2	<0.2	<0.2	<0.2	<0.21	<0.21

µg/l micrograms per liter.

Bold Bolded result indicates positively identified compound.

- Not analyzed.

D Sample dilution required for analysis; reported values reflect the dilution.

J Data are estimated due to associated quality control data.

T Analyte was positively identified but the reported concentration is estimated; reported concentration is less than the reporting limit, but greater than the method detection limit.

TABLE 27

EPA 608 PESTICIDES/POLYCHLORINATED BIPHENYLS WATER SAMPLE DATA SUMMARY
DEMONSTRATION TESTING AND FULL-SCALE OPERATION OF THE BIOGENESIS SEDIMENT DECONTAMINATION PROCESS
KEASBEY, NEW JERSEY
 (Page 13 of 16)

Field Sample Identification	WW-1600306-1700	WW-170306-1400	WW-300306-1300	WW-070406-1530	WW-120406-1000	WW-200406-1400
Date Collected	3/16/06	3/17/06	3/30/06	4/7/06	4/12/06	4/20/06
Matrix	Water	Water	Water	Water	Water	Water
Analyte/Methods (Units)						
Pesticides/EPA608 (µg/l)						
Aldrin	<0.01	<0.011	<0.01	<0.01	<0.01	<0.01
alpha BHC	<0.01	<0.011	<0.01	<0.01	<0.01	<0.01
alpha Endosulfan	<0.01	<0.011	<0.01	<0.01	<0.01	<0.01
alpha-Chlordane	-	-	-	-	-	-
beta BHC	<0.01	<0.011	<0.01	<0.01	<0.01	<0.01
beta Endosulfan	<0.01	<0.011	<0.01	<0.01	<0.01	<0.01
Chlordane	<0.1	<0.11	<0.1	<0.1	<0.1	<0.1
delta BHC	<0.01	<0.011	<0.01	<0.01	<0.01	<0.01
Dieldrin	<0.01	<0.011	<0.01	<0.01	<0.01	<0.01
Endosulfan sulfate	<0.01	<0.011	<0.01	<0.01	<0.01	<0.01
Endrin	<0.01	<0.011	<0.01	<0.01	<0.01	<0.01
Endrin aldehyde	<0.01	<0.011	<0.01	<0.01	<0.01	<0.01
Endrin ketone	-	-	-	-	-	-
gamma BHC (Lindane)	<0.01	<0.011	<0.01	<0.01	<0.01	<0.01
gamma-Chlordane	-	-	-	-	-	-
Heptachlor	<0.01	<0.011	<0.01	<0.01	<0.01	<0.01
Heptachlor epoxide	<0.01	<0.011	<0.01	<0.01	<0.01	<0.01
Methoxychlor	-	-	-	-	-	-
p,p'-DDD	<0.01	<0.011	<0.01	<0.01	<0.01	0.0034 T
p,p'-DDE	<0.01	<0.011	<0.01	<0.01	<0.01	<0.01
p,p'-DDT	<0.01	<0.011	<0.01	<0.01	<0.01	<0.01
Toxaphene	<0.41	<0.42	<0.41	<0.41	<0.41	<0.41

TABLE 27

EPA 608 PESTICIDES/POLYCHLORINATED BIPHENYLS WATER SAMPLE DATA SUMMARY
DEMONSTRATION TESTING AND FULL-SCALE OPERATION OF THE BIOGENESIS SEDIMENT DECONTAMINATION PROCESS
KEASBEY, NEW JERSEY
(Page 14 of 16)

Field Sample Identification	WW-1600306-1700	WW-170306-1400	WW-300306-1300	WW-070406-1530	WW-120406-1000	WW-200406-1400
Date Collected	3/16/06	3/17/06	3/30/06	4/7/06	4/12/06	4/20/06
Matrix	Water	Water	Water	Water	Water	Water
Analyte/Methods (Units)						
Polychlorinated Biphenyls/EPA608 (µg/l)						
PCB-1016 (Arochlor 1016)	<0.2	<0.21	<0.21	<0.2	<0.2	<0.21
PCB-1221 (Arochlor 1221)	<0.2	<0.21	<0.21	<0.2	<0.2	<0.21
PCB-1232 (Arochlor 1232)	<0.2	<0.21	<0.21	<0.2	<0.2	<0.21
PCB-1242 (Arochlor 1242)	<0.2	<0.21	<0.21	<0.2	<0.2	<0.21
PCB-1248 (Arochlor 1248)	<0.2	<0.21	<0.21	<0.2	<0.2	<0.21
PCB-1254 (Arochlor 1254)	<0.2	<0.21	<0.21	<0.2	<0.2	<0.21
PCB-1260 (Arochlor 1260)	<0.2	<0.21	<0.21	<0.2	<0.2	<0.21

µg/l micrograms per liter.

Bold Bolded result indicates positively identified compound.

- Not analyzed.

D Sample dilution required for analysis; reported values reflect the dilution.

J Data are estimated due to associated quality control data.

T Analyte was positively identified but the reported concentration is estimated; reported concentration is less than the reporting limit, but greater than the method detection limit.

TABLE 27

EPA 608 PESTICIDES/POLYCHLORINATED BIPHENYLS WATER SAMPLE DATA SUMMARY
DEMONSTRATION TESTING AND FULL-SCALE OPERATION OF THE BIOGENESIS SEDIMENT DECONTAMINATION PROCESS
KEASBEY, NEW JERSEY
 (Page 15 of 16)

Field Sample Identification	WW-260406-1000	WW-040506-1100	WW-120506-1100	WW-170506-1100
Date Collected Matrix	4/26/06 Water	5/4/06 Water	5/12/06 Water	5/17/06 Water
Analyte/Methods (Units)				
Pesticides/EPA608 (µg/l)				
Aldrin	<0.01	<0.01	<0.01	<0.01
alpha BHC	<0.01	<0.01	<0.01	<0.01
alpha Endosulfan	<0.01	<0.01	<0.01	<0.01
alpha-Chlordane	-	-	-	-
beta BHC	<0.01	<0.01	<0.01	<0.01
beta Endosulfan	0.015	<0.01	<0.01	<0.01
Chlordane	<0.1	<0.1	<0.1	<0.1
delta BHC	<0.01	<0.01	<0.01	<0.01
Dieldrin	<0.01	<0.01	0.0036 TJ	<0.01
Endosulfan sulfate	<0.01	<0.01	<0.01	<0.01
Endrin	0.0043 T	<0.01	<0.01	<0.01
Endrin aldehyde	<0.01	<0.01	<0.01	<0.01
Endrin ketone	-	-	-	-
gamma BHC (Lindane)	<0.01	<0.01	<0.01	<0.01
gamma-Chlordane	-	-	-	-
Heptachlor	<0.01	<0.01	<0.01	<0.01
Heptachlor epoxide	<0.01	<0.01	<0.01	<0.01
Methoxychlor	-	-	-	-
p,p'-DDD	0.0068 T	0.0039 T	<0.01	<0.01
p,p'-DDE	<0.01	<0.01	<0.01	0.0034 TJ
p,p'-DDT	0.022	<0.01	<0.01	<0.01
Toxaphene	<0.4	<0.41	<0.4	<0.41

TABLE 27

**EPA 608 PESTICIDES/POLYCHLORINATED BIPHENYLS WATER SAMPLE DATA SUMMARY
 DEMONSTRATION TESTING AND FULL-SCALE OPERATION OF THE BIOGENESIS SEDIMENT DECONTAMINATION PROCESS
 KEASBEY, NEW JERSEY
 (Page 16 of 16)**

Field Sample Identification	WW-260406-1000	WW-040506-1100	WW-120506-1100	WW-170506-1100
Date Collected Matrix	4/26/06 Water	5/4/06 Water	5/12/06 Water	5/17/06 Water
Analyte/Methods (Units)				
Polychlorinated Biphenyls/EPA608 (µg/l)				
PCB-1016 (Arochlor 1016)	<0.2	<0.2	<0.2	<0.2
PCB-1221 (Arochlor 1221)	<0.2	<0.2	<0.2	<0.2
PCB-1232 (Arochlor 1232)	<0.2	<0.2	<0.2	<0.2
PCB-1242 (Arochlor 1242)	<0.2	<0.2	<0.2	<0.2
PCB-1248 (Arochlor 1248)	<0.2	<0.2	<0.2	<0.2
PCB-1254 (Arochlor 1254)	<0.2	<0.2	<0.2	<0.2
PCB-1260 (Arochlor 1260)	<0.2	<0.2	<0.2	<0.2

µg/l micrograms per liter.

Bold Bolded result indicates positively identified compound.

- Not analyzed.

D Sample dilution required for analysis; reported values reflect the dilution.

J Data are estimated due to associated quality control data.

T Analyte was positively identified but the reported concentration is estimated; reported concentration is less than the reporting limit, but greater than the method detection limit.

TABLE 28

SW8081A PESTICIDES WATER SAMPLE DATA SUMMARY
DEMONSTRATION TESTING AND FULL-SCALE OPERATION OF THE BIOGENESIS SEDIMENT DECONTAMINATION PROCESS
KEASBEY, NEW JERSEY
 (Page 1 of 1)

Field Sample Identification	WW-271205-1600	WW-291205-1120
Date Collected	12/27/05	12/29/05
Matrix	Water	Water
Analyte/Methods (Units)		
Pesticides/SW8081A (µg/l)		
Aldrin	<0.05	<0.05
alpha BHC	<0.05	<0.05
alpha Endosulfan	<0.05	<0.05
alpha-Chlordane	<0.05	<0.05
beta BHC	<0.05	<0.05
beta Endosulfan	<0.05	<0.05
Chlordane	<0.5	<0.5
delta BHC	<0.05	<0.05
Dieldrin	<0.05	<0.05
Endosulfan sulfate	<0.05	<0.05
Endrin	<0.05	<0.05
Endrin aldehyde	<0.05	<0.05
Endrin ketone	<0.05	<0.05
gamma BHC (Lindane)	<0.05	<0.05
gamma-Chlordane	<0.05	<0.05
Heptachlor	<0.05	<0.05
Heptachlor epoxide	<0.05	<0.05
Methoxychlor	<0.1	<0.1
p,p'-DDD	<0.05	<0.05
p,p'-DDE	<0.05	<0.05
p,p'-DDT	<0.05	<0.05
Toxaphene	<2.0	<2.0

µg/l micrograms per liter.

TABLE 29

SW8082 POLYCHLORINATED BIPHENYLS WATER SAMPLE DATA SUMMARY
DEMONSTRATION TESTING AND FULL-SCALE OPERATION OF THE BIOGENESIS SEDIMENT DECONTAMINATION PROCESS
KEASBEY, NEW JERSEY
(Page 1 of 1)

Location Identification Field Sample Identification Date Collected Matrix	WW WW-211205-1600 12/21/05 Water	WW WW-271205-1600 12/27/05 Water	WW WW-291205-1120 12/29/05 Water
Analyte/Methods (Units)			
Polychlorinated Biphenyls/SW8082 (ng/l)			
2-Chlorobiphenyl	<22 D	<10	<10
2,3-Dichlorobiphenyl	<2.2 D	<1.0	<1.0
2,2',5-Trichlorobiphenyl	<2.2 D	<1.0	<1.0
2,4',5-Trichlorobiphenyl	<2.2 D	<1.0	<1.0
2,2',5,5'-Tetrachlorobiphenyl	<2.2 D	<1.0	<1.0
2,3',4,4'-Tetrachlorobiphenyl	<2.2 D	<1.0	<1.0
2,2',3,4,5'-Pentachlorobiphenyl	<2.2 D	<1.0	<1.0
2,2',4,5,5'-Pentachlorobiphenyl	<2.2 D	<1.0	<1.0
2,3,3',4',6-Pentachlorobiphenyl	<2.2 D	<1.0	<1.0
2,2',3,4,5,5'-Hexachlorobiphenyl	<2.2 D	<1.0	<1.0
2,2',3,5,5',6-Hexachlorobiphenyl	<2.2 D	<1.0	<1.0
2,2',4,4',5,5'-Hexachlorobiphenyl	<2.2 D	<1.0	<1.0
2,2',3,3',4,4',5-Heptachlorobiphenyl	<2.2 D	<1.0	<1.0
2,2',3,4',5,5',6-Heptachlorobiphenyl	<2.2 D	<1.0	<1.0
2,2',3,4,4',5,5'-Heptachlorobiphenyl	<2.2 D	<1.0	<1.0
2,2',3,3',4,4',5,5',6-Nonachlorobiphenyl	<2.2 D	<1.0	<1.0

D Sample dilution required for analysis; reported values reflect the dilution.
ng/l nanograms per liter

TABLE 30

**2,3,7,8-TETRACHLORODIBENZO-P-DIOXIN WATER SAMPLE DATA SUMMARY
 DEMONSTRATION TESTING AND FULL-SCALE OPERATION OF THE
 BIOGENESIS SEDIMENT DECONTAMINATION PROCESS
 KEASBEY, NEW JERSEY
 (Page 1 of 2)**

Location Identification	Field Sample Identification	Date Collected	Matrix	2,3,7,8-Tetrachloro-dibenzo-p-dioxin	Analytical Method	Units
WW	WW-030106-1200	01/03/06	Water	<0.23	SW8082	ng/l
WW	WW-050106-1515	01/05/06	Water	<0.7	SW8082	ng/l
WW	WW-060106-1530	01/06/06	Water	<0.48	SW8082	ng/l
WW	WW-090106-1530	01/09/06	Water	<0.25	SW8082	ng/l
WW	WW-100106-1603	01/10/06	Water	<0.82	SW8082	ng/l
WW	WW-110106-1632	01/11/06	Water	<0.39	SW8082	ng/l
WW	WW-120106-1603	01/12/06	Water	<0.22	SW8082	ng/l
WW	WW-130106-1430	01/13/06	Water	<0.28	SW8082	ng/l
WW	WW-170106-1400	01/17/06	Water	<0.12	SW8082	ng/l
WW	WW-180106-1600	01/18/06	Water	<0.092	SW8082	ng/l
WW	WW-190106-1603	01/19/06	Water	<0.63	SW8082	ng/l
WW	WW-200106-1530	01/20/06	Water	<0.65	SW8082	ng/l
WW	WW-230106-1630	01/23/06	Water	<0.2	SW8082	ng/l
WW	WW-240106-1631	01/24/06	Water	<0.15	SW8082	ng/l
WW	WW-250106-1530	01/25/06	Water	<5.3	EPA1613	pg/l
WW	WW-300106-1703	01/30/06	Water	<5.0	EPA1613	pg/l
WW	WW-310106-1703	01/31/06	Water	<5.1	EPA1613	pg/l
WW	WW-010206-1603	02/01/06	Water	<5.1	EPA1613	pg/l
WW	WW-020206-1803	02/02/06	Water	<5.2	EPA1613	pg/l
WW	WW-030206-1203	02/03/06	Water	<5.3	EPA1613	pg/l
WW	WW-070206-0930	02/07/06	Water	<5.3	EPA1613	pg/l
WW	WW-080206-0930	02/08/06	Water	<5.4	EPA1613	pg/l
WW	WW-090206-0930	02/09/06	Water	<5.3	EPA1613	pg/l
WW	WW-100206-1000	02/10/06	Water	<5.3	EPA1613	pg/l
WW	WW-140206-0900	02/14/06	Water	<0.22	SW8082	ng/l
WW	WW-160206-1200	02/16/06	Water	<0.17	SW8082	ng/l
WW	WW-220206-1500	02/22/06	Water	<0.15	SW8082	ng/l
CAR	CARBON FILTERS-PRIMARY	02/24/06	Water	<0.19	SW8082	ng/l
WW	WW-280206-0900	02/28/06	Water	<0.84	SW8082	ng/l
WW	WW-010306-0900	03/01/06	Water	<0.3	SW8082	ng/l
WW	WW-010306-0900	03/02/06	Water	<0.042	SW8082	ng/l
WW	WW-030306-1100	03/03/06	Water	<0.034	SW8082	ng/l
WW	WW-140306-1600	03/14/06	Water	<0.045	SW8082	ng/l

10/29/09

Table 30 2378TCDD - Water.xls

TABLE 30

**2,3,7,8-TETRACHLORODIBENZO-P-DIOXIN WATER SAMPLE DATA SUMMARY
 DEMONSTRATION TESTING AND FULL-SCALE OPERATION OF THE
 BIOGENESIS SEDIMENT DECONTAMINATION PROCESS
 KEASBEY, NEW JERSEY
 (Page 2 of 2)**

Location Identification	Field Sample Identification	Date Collected	Matrix	2,3,7,8-Tetrachloro-dibenzo-p-dioxin	Analytical Method	Units
WW	WW-150306-1700	03/15/06	Water	<1.1	SW8082	ng/l
WW	WW-1600306-1700	03/16/06	Water	<0.087	SW8082	ng/l
WW	WW-170306-1400	03/17/06	Water	<0.74	SW8082	ng/l
WW	WW-300306-1300	03/30/06	Water	<0.12	SW8082	ng/l
WW	WW-070406-1530	04/07/06	Water	<0.085	SW8082	ng/l
WW	WW-120406-1000	04/12/06	Water	<0.21	SW8082	ng/l
WW	WW-200406-1400	04/20/06	Water	<0.079	SW8082	ng/l
WW	WW-260406-1000	04/26/06	Water	<0.031	SW8082	ng/l
WW	WW-040506-1100	05/04/06	Water	<0.24	SW8082	ng/l
WW	WW-120506-1100	05/12/06	Water	<0.15	SW8082	ng/l
WW	WW-170506-1100	05/17/06	Water	<0.12	SW8082	ng/l

ng/l nanograms per liter

pg/l picograms per liter

TABLE 31

DIOXIN/FURAN WATER SAMPLE DATA SUMMARY
DEMONSTRATION TESTING AND FULL-SCALE OPERATION OF THE BIOGENESIS SEDIMENT DECONTAMINATION PROCESS
KEASBEY, NEW JERSEY
(Page 1 of 1)

Field Sample Identification Date Collected Matrix	WW-271205-1600 12/27/05 Water	WW-291205-1120 12/29/05 Water
Analyte/Methods (Units)		
Dioxins/Furans/SW8082 (ng/l)		
1,2,3,4,6,7,8-Heptachlorodibenzo-p-dioxin	0.76 T	<50
1,2,3,4,6,7,8-Heptachlorodibenzofuran	<50	<50
1,2,3,4,7,8,9-Heptachlorodibenzofuran	<50	<50
1,2,3,4,7,8-Hexachlorodibenzo-p-dioxin	<50	<50
1,2,3,4,7,8-Hexachlorodibenzofuran	<50	<50
1,2,3,6,7,8-Hexachlorodibenzo-p-dioxin	<50	<50
1,2,3,6,7,8-Hexachlorodibenzofuran	<50	<50
1,2,3,7,8,9-Hexachlorodibenzo-p-dioxin	<50	<50
1,2,3,7,8,9-Hexachlorodibenzofuran	<50	<50
1,2,3,7,8-Pentachlorodibenzo-p-dioxin	<50	<50
1,2,3,7,8-Pentachlorodibenzofuran	<50	<50
2,3,4,6,7,8-Hexachlorodibenzofuran	<50	<50
2,3,4,7,8-Pentachlorodibenzofuran	<50	<50
2,3,7,8-Tetrachlorodibenzo-p-dioxin	<10	<10
2,3,7,8-Tetrachlorodibenzofuran	<10	<10
Octachlorodibenzo-p-dioxin	6.2 T	5.0 T
Octachlorodibenzofuran	<100	<100

Bold Bolded result indicates positively identified compound.
T Analyte was positively identified but the reported concentration is estimated; reported concentration is less than the reporting limit, but greater than the method detection limit.
ng/l nanograms per liter

TABLE 32

EPA 200 METALS WATER SAMPLE DATA SUMMARY
DEMONSTRATION TESTING AND FULL-SCALE OPERATION OF THE BIOGENESIS SEDIMENT DECONTAMINATION PROCESS
KEASBEY, NEW JERSEY
 (Page 1 of 8)

Field Sample Identification	WW-291205-1120	WW-030106-1200	WW-040106-1545	WW-050106-1515	WW-060106-1530	WW-090106-1530	WW-100106-1603
Date Collected	12/29/05	1/3/06	1/4/06	1/5/06	1/6/06	1/9/06	1/10/06
Matrix	Water	Water	Water	Water	Water	Water	Water
Analyte/Methods (Units)							
Metals/EPA200 (µg/l)							
Arsenic	203	<10	140	92.5	43.2	23.6	22.5
Barium	29 T	31.9 T	34.8 T	36.9 T	63.6 T	50.7 T	47.3 T
Cadmium	<5.0	<5.0	<5.0	<5.0	<5.0	<5	<5.0
Chromium, Total	1.2 T	2.4 T	1.0 T	<5.0	0.84 T	<5	<5.0
Copper	-	-	-	-	-	2.2 T	-
Lead	2.4 T	2.7 T	<3.0	<3.0	<3.0	<3	<3.0
Mercury	<0.2	<0.2	<0.2	<0.2	<0.2	<0.2	<0.2
Nickel	9.1 T	22.4 T	9.6 T	10 T	11.1 T	10.7 T	10.2 T
Selenium	<5.0	<5.0	<5.0	4.5 T	<5.0	<5	<5.0
Silver	<5.0	<5.0	<5.0	<5.0	<5.0	<5	<5.0
Zinc	42.4 J	11.9 T	29.1 J	16.9 T	12.2 T	44.5	5.2 T

µg/l micrograms per liter.

Bold Bolded result indicates positively identified compound.

- Not analyzed.

B Analyte detected in an associated blank.

D Sample dilution required for analysis; reported values reflect the dilution.

J Data are estimated due to associated quality control data.

T Analyte was positively identified but the reported concentration is estimated; reported concentration is less than the reporting limit, but greater than the method detection limit.

TABLE 32

EPA 200 METALS WATER SAMPLE DATA SUMMARY
DEMONSTRATION TESTING AND FULL-SCALE OPERATION OF THE BIOGENESIS SEDIMENT DECONTAMINATION PROCESS
KEASBEY, NEW JERSEY
 (Page 2 of 8)

Field Sample Identification	WW-110106-1632	WW-120106-1603	WW-130106-1430	WW-170106-1400	WW-180106-1600	WW-190106-1603	WW-200106-1530
Date Collected	1/11/06	1/12/06	1/13/06	1/17/06	1/18/06	1/19/06	1/20/06
Matrix	Water	Water	Water	Water	Water	Water	Water
Analyte/Methods (Units)							
Metals/EPA200 (µg/l)							
Arsenic	24.7	16.7	18.7	32.1	18.9	11.4	6.8 T
Barium	47.4 T	46.3 T	65 T	71.4 T	49.3 T	57.2 T	39.7 T
Cadmium	<5.0	<5.0	<5.0	<5.0	<5.0	<5.0	<5
Chromium, Total	1.6 T	<5.0	<5.0	<5.0	2.1 T	<5.0	0.87 T
Copper	-	-	3.0 T	4.4 T	4.2 T	0.76 T	1.7 T
Lead	<3.0	<3.0	<3.0	<3.0	<3.0	<3.0	<3
Mercury	<0.2	<0.2	<0.2	<0.2	<0.2	<0.2	<0.2
Nickel	10.4 T	9.7 T	30 T	27.2 T	29.3 T	25.8 T	29.1 T
Selenium	<5.0	<5.0	-	-	-	-	-
Silver	<5.0	<5.0	<5.0	<5.0	<5.0	<5.0	0.45 T
Zinc	16.4 T	7.2 T	4.8 T	9.2 T	13.6 T	333 J	42.2 J

µg/l micrograms per liter.

Bold Bolded result indicates positively identified compound.

- Not analyzed.

B Analyte detected in an associated blank.

D Sample dilution required for analysis; reported values reflect the dilution.

J Data are estimated due to associated quality control data.

T Analyte was positively identified but the reported concentration is estimated; reported concentration is less than the reporting limit, but greater than the method detection limit.

TABLE 32

EPA 200 METALS WATER SAMPLE DATA SUMMARY
DEMONSTRATION TESTING AND FULL-SCALE OPERATION OF THE BIOGENESIS SEDIMENT DECONTAMINATION PROCESS
KEASBEY, NEW JERSEY
 (Page 3 of 8)

Field Sample Identification	WW-230106-1630	WW-240106-1631	WW-250106-1530	WW-300106-1703	WW-310106-1703	WW-010206-1603	WW-020206-1803
Date Collected	1/23/06	1/24/06	1/25/06	1/30/06	1/31/06	2/1/06	2/2/06
Matrix	Water	Water	Water	Water	Water	Water	Water
Analyte/Methods (Units)							
Metals/EPA200 (µg/l)							
Arsenic	9.5 T	7.7 T	9.0 T	9.4 T	5.6 T	4.6 T;4.6 T	6.9 T
Barium	49 T	36.7 T	50.3 T	42.1 T	55.1 T	56.9 T;56.9 T	64.2 T
Cadmium	<5.0	<5.0	<5.0	<5	4.8 T	19.4;19.4	18.6
Chromium, Total	2.9 T	1.8 T	<5.0	1.7 T	6.4	4.6 T;4.6 T	1.9 T
Copper	1.4 T	1.0 T	13.7 T	21.6 T	124	1080;1080	1150
Lead	<3.0	<3.0	<3.0	<3	14.1	271;271	593
Mercury	0.061 T	<0.2	<0.2	<0.2	<0.2	<0.2;<0.2	<0.2
Nickel	15.4 T	5.3 T	16.3 T	318	552	342;342	346
Selenium	-	-	-	-	-	-	-
Silver	<5.0	0.45 T	<5.0	<5	<5.0	<5;<5.0	<5.0
Zinc	11.6 T	3.1 T	85.1	92.4 J	1600 J	4240 J	3190 J

µg/l micrograms per liter.

Bold Bolded result indicates positively identified compound.

- Not analyzed.

B Analyte detected in an associated blank.

D Sample dilution required for analysis; reported values reflect the dilution.

J Data are estimated due to associated quality control data.

T Analyte was positively identified but the reported concentration is estimated; reported concentration is less than the reporting limit, but greater than the method detection limit.

TABLE 32

EPA 200 METALS WATER SAMPLE DATA SUMMARY
DEMONSTRATION TESTING AND FULL-SCALE OPERATION OF THE BIOGENESIS SEDIMENT DECONTAMINATION PROCESS
KEASBEY, NEW JERSEY
 (Page 4 of 8)

Field Sample Identification	WW-030206-1203	WW-070206-0930	WW-080206-0930	WW-090206-0930	WW-100206-1000	WW-140206-0900	WW-160206-1200
Date Collected	2/3/06	2/7/06	2/8/06	2/9/06	2/10/06	2/14/06	2/16/06
Matrix	Water	Water	Water	Water	Water	Water	Water
Analyte/Methods (Units)							
Metals/EPA200 (µg/l)							
Arsenic	8.7 T	12	10;10	6.8 T	6.4 T	11.4	13.9
Barium	51.2 T	57 T	54.5 T;54.5 T	56.4 T	42.1 T	68.1 T	68.3 T
Cadmium	21.1	19.8	9.1;9.1	2.9 T	3.2 T	3.4 T	2.9 T
Chromium, Total	1.9 T	1.3 T	1.6 T;1.6 T	1.0 T	1.3 T	1.1 T	<5
Copper	1330	958	581;581	188 J	206 J	118	92.1
Lead	682	798	495;495	211	211	123	86.8
Mercury	<0.2	0.052 T	<0.2;<0.2	<0.2	<0.2	0.077 T	<0.2
Nickel	353	427	276;276	124	101	128 J	137 J
Selenium	-	-	-	-	-	-	-
Silver	<5.0	<5.0	<5.0;<5	<5.0	0.62 T	0.73 T	<5
Zinc	3540 J	4060 J	1600 J;1600 J	2420 J	540 J	664 J	566 J

µg/l micrograms per liter.

Bold Bolded result indicates positively identified compound.

- Not analyzed.

B Analyte detected in an associated blank.

D Sample dilution required for analysis; reported values reflect the dilution.

J Data are estimated due to associated quality control data.

T Analyte was positively identified but the reported concentration is estimated; reported concentration is less than the reporting limit, but greater than the method detection limit.

TABLE 32

EPA 200 METALS WATER SAMPLE DATA SUMMARY
DEMONSTRATION TESTING AND FULL-SCALE OPERATION OF THE BIOGENESIS SEDIMENT DECONTAMINATION PROCESS
KEASBEY, NEW JERSEY
 (Page 5 of 8)

Field Sample Identification	WW-170206-0900	WW-220206-1500	CARBON FILTERS- PRIMARY	WW-280206-0900	WW-010306-0900	CENTRATE 1	CENTRATE 1
Date Collected	2/17/06	2/22/06	2/24/06	2/28/06	3/1/06	3/2/06	3/2/06
Matrix	Water	Water	Water	Water	Water	Water	Water
Analyte/Methods (Units)							
Metals/EPA200 (µg/l)							
Arsenic	9.8 T	22	6.6 T	11.4	5.2 T	4.1 T	3.9 T
Barium	60.9 T	97.2 T	113 T	120 T	65.3 T	40.4 T	36 T
Cadmium	1.3 T	1.1 T	0.49 T	<5.0	<5.0	1.3 T	1.1 T
Chromium, Total	<5.0	1.1 T	5.7	<5.0	0.99 T	8.5	2.6 T
Copper	75.5	12.6 T	7.4 T	10.4 T	1.4 T	16.4 T	7.9 T
Lead	53.3 J	23.6	21.8	13.3	17.3	207	205
Mercury	0.053 T	<0.2	<0.2	<0.2	<0.2	0.24	<0.2
Nickel	85.5	87	79.2	110	142	396	405
Selenium	-	-	-	-	-	-	-
Silver	0.49 T	0.52 T	<5.0	<5.0	0.86 T	1 T	0.89 T
Zinc	283 J	293	3740 J	708 J	224 J	1280	1320

µg/l micrograms per liter.

Bold Bolded result indicates positively identified compound.

- Not analyzed.

B Analyte detected in an associated blank.

D Sample dilution required for analysis; reported values reflect the dilution.

J Data are estimated due to associated quality control data.

T Analyte was positively identified but the reported concentration is estimated; reported concentration is less than the reporting limit, but greater than the method detection limit.

TABLE 32

EPA 200 METALS WATER SAMPLE DATA SUMMARY
DEMONSTRATION TESTING AND FULL-SCALE OPERATION OF THE BIOGENESIS SEDIMENT DECONTAMINATION PROCESS
KEASBEY, NEW JERSEY
 (Page 6 of 8)

Field Sample Identification	CENTRATE 2	CENTRATE 2	WW-010306-0900	WW-030306-1100	WW-140306-1600	WW-150306-1700	WW-1600306-1700
Date Collected	3/2/06	3/2/06	3/2/06	3/3/06	3/14/06	3/15/06	3/16/06
Matrix	Water	Water	Water	Water	Water	Water	Water
Analyte/Methods (Units)							
Metals/EPA200 (µg/l)							
Arsenic	1050	7 T	<10	<10;<10	3.8 T	4.6 T	5.3 T
Barium	5750	43.7 T	40.9 T	38.2 T;38.2 T	86.8 T	93.2 T	83.5 T
Cadmium	440 D	0.87 T	0.34 T	0.4 T;0.4 T	<5.0	<5.0	<5.0
Chromium, Total	7630	6.8	1.4 T	1.6 T;1.6 T	1.4 T	1.2 T	1.2 T
Copper	28600 D	15.5 T	0.64 T	3.2 T;3.2 T	4.4 T	8.3 T	3.0 T
Lead	17100 D	428	67.3	49	<3.0	<3.0	<3.0
Mercury	822 D	0.11 T	<0.2	<0.2;<0.2	<0.2	<0.2	0.086 T
Nickel	1400	591	303	337	286	240	196
Selenium	-	-	-	-	-	-	-
Silver	203	0.6 T	<5	<5.0;<5	<5.0	<5.0	<5.0
Zinc	28200 D	1960	352	435 J	127 J	34.3 J	15.6 T

µg/l micrograms per liter.

Bold Bolded result indicates positively identified compound.

- Not analyzed.

B Analyte detected in an associated blank.

D Sample dilution required for analysis; reported values reflect the dilution.

J Data are estimated due to associated quality control data.

T Analyte was positively identified but the reported concentration is estimated; reported concentration is less than the reporting limit, but greater than the method detection limit.

TABLE 32

EPA 200 METALS WATER SAMPLE DATA SUMMARY
DEMONSTRATION TESTING AND FULL-SCALE OPERATION OF THE BIOGENESIS SEDIMENT DECONTAMINATION PROCESS
KEASBEY, NEW JERSEY
 (Page 7 of 8)

Field Sample Identification	WW-170306-1400	WW-21036-1800	WWC1-220306-1025	WWC1-220306-1025	WW-300306-1300	WW-070406-1530	WW-120406-1000
Date Collected	3/17/06	3/21/06	3/22/06	3/22/06	3/30/06	4/7/06	4/12/06
Matrix	Water	Water	Water	Water	Water	Water	Water
Analyte/Methods (Units)							
Metals/EPA200 (µg/l)							
Arsenic	7.4 T	6.1 T	1660 D	6.8 T	<10	<10	3.2 T
Barium	92.1 T	180 T	7380 JD	103 T	80.6 T	61.4 T	49.6 T
Cadmium	<5.0	0.75 T	433 D	0.64 T	<5.0	<5.0	0.38 T
Chromium, Total	0.86 T	1.6 T	13500 D	2.5 T	<5.0	<5.0	2.4 T
Copper	3.5 T	357	27000 D	10.7 T	17.3 T	<25	5.4 T
Lead	<3.0	39.7	18200 D	454	3.8	5.3	<3.0
Mercury	<0.2	<0.2	667 D	<0.2	<0.2	<0.2	0.053 T
Nickel	183	278	2540 D	489	361	93	41.4
Selenium	-	-	-	-	-	-	-
Silver	<5.0	<5.0	342 D	0.85 T	<5.0	<5.0	0.8 T
Zinc	14.9 T	1020 J	29100 JD	1450 J	95.9 J	12.7 T	10.5 T

µg/l micrograms per liter.

Bold Bolded result indicates positively identified compound.

- Not analyzed.

B Analyte detected in an associated blank.

D Sample dilution required for analysis; reported values reflect the dilution.

J Data are estimated due to associated quality control data.

T Analyte was positively identified but the reported concentration is estimated; reported concentration is less than the reporting limit, but greater than the method detection limit.

TABLE 32

EPA 200 METALS WATER SAMPLE DATA SUMMARY
DEMONSTRATION TESTING AND FULL-SCALE OPERATION OF THE BIOGENESIS SEDIMENT DECONTAMINATION PROCESS
KEASBEY, NEW JERSEY
(Page 8 of 8)

Field Sample Identification	WW-200406-1400	WW-260406-1000	WW-040506-1100	WW-120506-1100	WW-170506-1100
Date Collected	4/20/06	4/26/06	5/4/06	5/12/06	5/17/06
Matrix	Water	Water	Water	Water	Water
Analyte/Methods (Units)					
Metals/EPA200 (µg/l)					
Arsenic	3.8 T	4.2 T	<10	15.5	10.5
Barium	55.4 T	54.5 T	37.2 T	25.9 TB	49.4 TB
Cadmium	<5.0	<5.0	8.1	3.8 TB	5.9
Chromium, Total	0.91 T	1.2 T	4.0 T	3.6 T	5.7
Copper	10.7 T	8.0 T	10.1 T	12.5 T	17.2 T
Lead	<3.0	<3.0	1270	453	265
Mercury	<0.2	<0.2	<0.2	<0.2	0.19 TB
Nickel	11.8 T	5.7 T	571	233	279
Selenium	-	-	-	-	-
Silver	<5.0	<5.0	2.0 T	<5	<5.0
Zinc	40.7 J	9.3 T	736 J	160 JB	542 JB

µg/l micrograms per liter.

Bold Bolded result indicates positively identified compound.

- Not analyzed.

B Analyte detected in an associated blank.

D Sample dilution required for analysis; reported values reflect the dilution.

J Data are estimated due to associated quality control data.

T Analyte was positively identified but the reported concentration is estimated; reported concentration is less than the reporting limit, but greater than the method detection limit.

TABLE 33

SW6010B METALS WATER SAMPLE DATA SUMMARY
DEMONSTRATION TESTING AND FULL-SCALE OPERATION OF THE BIOGENESIS SEDIMENT DECONTAMINATION PROCESS
KEASBEY, NEW JERSEY
(Page 1 of 1)

Field Sample Identification	WW-211205-1600	WW2-221205-1430	WW-271205-1600
Date Collected	12/21/05	12/22/05	12/27/05
Matrix	Water	Water	Water
Analyte/Methods (Units)			
Metals/SW6010B (µg/l)			
Arsenic	648	818 D	422
Barium	19.4 T	1900 JD	22.3 T
Cadmium	<5.0	13.6 TD	<5.0
Chromium, Total	3.7 T	1150 D	2.6 T
Lead	<3.0	2380 D	<3.0
Mercury	<0.2	21.1 D	<0.2
Nickel	5.6 T	1030 D	7.0 T
Selenium	5.4	64.8 D	<5.0
Silver	0.78 T	17.3 TD	0.54 T
Zinc	65 J	4540 JD	12 T

µg/l micrograms per liter.

Bold Bolded result indicates positively identified compound.

D Sample dilution required for analysis; reported values reflect the dilution.

J Data are estimated due to associated quality control data.

T Analyte was positively identified but the reported concentration is estimated; reported concentration is less than the reporting limit, but greater than the method detection limit.

TABLE 34

WATER QUALITY PARAMETERS SAMPLE DATA SUMMARY
DEMONSTRATION TESTING AND FULL-SCALE OPERATION OF THE BIOGENESIS SEDIMENT DECONTAMINATION PROCESS
KEASBEY, NEW JERSEY
 (Page 1 of 11)

Field Sample Identification			WW2-221205-1430	WW-271205-1600	WW-291205-1120	WW-030106-1200	WW-040106-1545
Date Collected			12/22/05	12/27/05	12/29/05	01/03/06	01/04/06
Matrix			Water	Water	Water	Water	Water
Analyte/Methods (Units)							
pH	Method E150.1	N/A	-	-	-	-	8.4
Suspended Solids	Method E160.2	mg/L	23100 D	-	-	80	ND
Oil/Grease	Method E1664	mg/L	-	-	-	-	12.1 TD
Cyanide	Method E335.4	mg/L	-	-	-	<0.01	<0.01
Total Organic Carbon	Method E415.1	mg/L	-	2.0	1.6	-	-
Biologic oxygen demand, Five Day	Method E405.1	mg/L	-	-	-	-	0
COD - Chemical oxygen demand	Method E410.4	mg/L	271 D	-	-	33.9	21.4

- Not Analyzed

mg/l milligrams per liter.

Bold Bolded result indicates positively identified compound.

N/A Not applicable.

D Sample dilution required for analysis; reported values reflect the dilution.

J Data are estimated due to associated quality control data.

ND Not detected

T Analyte was positively identified but the reported concentration is estimated; reported concentration is less than the reporting limit, but greater than the method detection limit.

TABLE 34

WATER QUALITY PARAMETERS SAMPLE DATA SUMMARY
DEMONSTRATION TESTING AND FULL-SCALE OPERATION OF THE BIOGENESIS SEDIMENT DECONTAMINATION PROCESS
KEASBEY, NEW JERSEY
(Page 2 of 11)

Field Sample Identification			WW-050106-1515	WW-060106-1530	WW-090106-1530	WW-100106-1603	WW-110106-1632
Date Collected			01/05/06	01/06/06	01/09/06	01/10/06	01/11/06
Matrix			Water	Water	Water	Water	Water
Analyte/Methods (Units)							
pH	Method E150.1	N/A	8.1	8.5	7.4	9.2	9.0
Suspended Solids	Method E160.2	mg/L	5.2	ND	ND	ND	ND
Oil/Grease	Method E1664	mg/L	<50 D	<50 D	<5	<5.0	<5.2
Cyanide	Method E335.4	mg/L	<0.01	<0.01	<0.01	<0.01	<0.01
Total Organic Carbon	Method E415.1	mg/L	-	-	-	-	-
Biologic oxygen demand, Five Day	Method E405.1	mg/L	0	5.7	7	3.8	5.5
COD - Chemical oxygen demand	Method E410.4	mg/L	31.4	88.5	103	101	134

- Not Analyzed

mg/l milligrams per liter.

Bold Bolded result indicates positively identified compound.

N/A Not applicable.

D Sample dilution required for analysis; reported values reflect the dilution.

J Data are estimated due to associated quality control data.

ND Not detected

T Analyte was positively identified but the reported concentration is estimated; reported concentration is less than the reporting limit, but greater than the method detection limit.

TABLE 34

WATER QUALITY PARAMETERS SAMPLE DATA SUMMARY
DEMONSTRATION TESTING AND FULL-SCALE OPERATION OF THE BIOGENESIS SEDIMENT DECONTAMINATION PROCESS
KEASBEY, NEW JERSEY
(Page 3 of 11)

Field Sample Identification			WW-120106-1603	WW-130106-1430	WW-170106-1400	WW-180106-1600	WW-190106-1603
Date Collected			01/12/06	01/13/06	01/17/06	01/18/06	01/19/06
Matrix			Water	Water	Water	Water	Water
Analyte/Methods (Units)							
pH	Method E150.1	N/A	9.1	8.7	8.4	8.4	8.4
Suspended Solids	Method E160.2	mg/L	ND	ND	4.4	7.6	5.6
Oil/Grease	Method E1664	mg/L	<5.1	<5.1	<5.0	<5.1	<5.0
Cyanide	Method E335.4	mg/L	<0.01	<0.01	<0.01	<0.01	<0.01
Total Organic Carbon	Method E415.1	mg/L	-	-	-	-	-
Biologic oxygen demand, Five Day	Method E405.1	mg/L	9.1	9.0	10.3	136	9.9
COD - Chemical oxygen demand	Method E410.4	mg/L	80.4	666	103	221	98.3

- Not Analyzed

mg/l milligrams per liter.

Bold Bolded result indicates positively identified compound.

N/A Not applicable.

D Sample dilution required for analysis; reported values reflect the dilution.

J Data are estimated due to associated quality control data.

ND Not detected

T Analyte was positively identified but the reported concentration is estimated; reported concentration is less than the reporting limit, but greater than the method detection limit.

TABLE 34

WATER QUALITY PARAMETERS SAMPLE DATA SUMMARY
DEMONSTRATION TESTING AND FULL-SCALE OPERATION OF THE BIOGENESIS SEDIMENT DECONTAMINATION PROCESS
KEASBEY, NEW JERSEY
(Page 4 of 11)

Analyte/Methods (Units)	Field Sample Identification		WW-200106-1530	WW-230106-1630	WW-240106-1631	WW-250106-1530	WW-300106-1703
	Date Collected	Matrix	01/20/06 Water	01/23/06 Water	01/24/06 Water	01/25/06 Water	01/30/06 Water
pH	Method E150.1	N/A	8	9.8	9.2	8.3	8.2
Suspended Solids	Method E160.2	mg/L	ND	ND	ND	ND	ND
Oil/Grease	Method E1664	mg/L	<5.2	<5.3	<5.0	<5.0	1.2 T
Cyanide	Method E335.4	mg/L	<0.01	<0.01	<0.01	<0.01	<0.01
Total Organic Carbon	Method E415.1	mg/L	-	-	-	-	-
Biologic oxygen demand, Five Day	Method E405.1	mg/L	12	12.7	14.4	2.3	8.5
COD - Chemical oxygen demand	Method E410.4	mg/L	57.4	39.6	47.2	77.9	167

- Not Analyzed

mg/l milligrams per liter.

Bold Bolded result indicates positively identified compound.

N/A Not applicable.

D Sample dilution required for analysis; reported values reflect the dilution.

J Data are estimated due to associated quality control data.

ND Not detected

T Analyte was positively identified but the reported concentration is estimated; reported concentration is less than the reporting limit, but greater than the method detection limit.

TABLE 34

WATER QUALITY PARAMETERS SAMPLE DATA SUMMARY
DEMONSTRATION TESTING AND FULL-SCALE OPERATION OF THE BIOGENESIS SEDIMENT DECONTAMINATION PROCESS
KEASBEY, NEW JERSEY
(Page 5 of 11)

Field Sample Identification			WW-310106-1703	WW-010206-1603	WW-020206-1803	WW-030206-1203	WW-070206-0930
Date Collected			01/31/06	02/01/06	02/02/06	02/03/06	02/07/06
Matrix			Water	Water	Water	Water	Water
Analyte/Methods (Units)							
pH	Method E150.1	N/A	7.8	7.8	7.7	7.7	7.5
Suspended Solids	Method E160.2	mg/L	ND	ND	ND	ND	6.4
Oil/Grease	Method E1664	mg/L	<5.0	<5.0	<5.0	<5.0	<5.0
Cyanide	Method E335.4	mg/L	<0.01	<0.01	<0.01	<0.01	<0.01
Total Organic Carbon	Method E415.1	mg/L	-	-	-	-	-
Biologic oxygen demand, Five Day	Method E405.1	mg/L	23.5	27.9	28.3	26	29.6
COD - Chemical oxygen demand	Method E410.4	mg/L	249	295	326	236	367

- Not Analyzed

mg/l milligrams per liter.

Bold Bolded result indicates positively identified compound.

N/A Not applicable.

D Sample dilution required for analysis; reported values reflect the dilution.

J Data are estimated due to associated quality control data.

ND Not detected

T Analyte was positively identified but the reported concentration is estimated; reported concentration is less than the reporting limit, but greater than the method detection limit.

TABLE 34
WATER QUALITY PARAMETERS SAMPLE DATA SUMMARY
DEMONSTRATION TESTING AND FULL-SCALE OPERATION OF THE BIOGENESIS SEDIMENT DECONTAMINATION PROCESS
KEASBEY, NEW JERSEY
(Page 6 of 11)

Field Sample Identification			WW-080206-0930	WW-090206-0930	WW-100206-1000	WW-140206-0900	WW-160206-1200
Date Collected			02/08/06	02/09/06	02/10/06	02/14/06	02/16/06
Matrix			Water	Water	Water	Water	Water
Analyte/Methods (Units)							
pH	Method E150.1	N/A	7.3;7.3	7.7	7.9	7.2	7.4
Suspended Solids	Method E160.2	mg/L	ND	ND	ND	ND	ND
Oil/Grease	Method E1664	mg/L	<5.0;<5	<5.1	<5.0	<5.0	<5
Cyanide	Method E335.4	mg/L	<0.01	<0.01	<0.01	<0.01	<0.01
Total Organic Carbon	Method E415.1	mg/L	-	-	-	-	-
Biologic oxygen demand, Five Day	Method E405.1	mg/L	19.4	18	57.2	15.4	37.8
COD - Chemical oxygen demand	Method E410.4	mg/L	178	149	248	711	557

- Not Analyzed
- mg/l milligrams per liter.
- Bold** Bolded result indicates positively identified compound.
- N/A Not applicable.
- D Sample dilution required for analysis; reported values reflect the dilution.
- J Data are estimated due to associated quality control data.
- ND Not detected
- T Analyte was positively identified but the reported concentration is estimated; reported concentration is less than the reporting limit, but greater than the method detection limit.

TABLE 34

WATER QUALITY PARAMETERS SAMPLE DATA SUMMARY
DEMONSTRATION TESTING AND FULL-SCALE OPERATION OF THE BIOGENESIS SEDIMENT DECONTAMINATION PROCESS
KEASBEY, NEW JERSEY
(Page 7 of 11)

Analyte/Methods (Units)	Field Sample Identification		WW-170206-0900	WW-220206-1500	CARBON FILTERS- PRIMARY	WW-280206-0900	WW-010306-0900
	Date Collected	Matrix	02/17/06 Water	02/22/06 Water	02/24/06 Water	02/28/06 Water	03/01/06 Water
pH	Method E150.1	N/A	7.4	6.9	8.1	6.7	6.9
Suspended Solids	Method E160.2	mg/L	ND	ND	ND	19.2	ND
Oil/Grease	Method E1664	mg/L	<5.0	<5.0	<5.0	<5.0	<5.0
Cyanide	Method E335.4	mg/L	<0.01	<0.01	<0.01	<0.01	<0.01
Total Organic Carbon	Method E415.1	mg/L	-	-	-	-	-
Biologic oxygen demand, Five Day	Method E405.1	mg/L	44	26.6	55.3	36.8	51.4
COD - Chemical oxygen demand	Method E410.4	mg/L	263	220 D	868 D	598 D	703

- Not Analyzed

mg/l milligrams per liter.

Bold Bolded result indicates positively identified compound.

N/A Not applicable.

D Sample dilution required for analysis; reported values reflect the dilution.

J Data are estimated due to associated quality control data.

ND Not detected

T Analyte was positively identified but the reported concentration is estimated; reported concentration is less than the reporting limit, but greater than the method detection limit.

TABLE 34

WATER QUALITY PARAMETERS SAMPLE DATA SUMMARY
DEMONSTRATION TESTING AND FULL-SCALE OPERATION OF THE BIOGENESIS SEDIMENT DECONTAMINATION PROCESS
KEASBEY, NEW JERSEY
(Page 8 of 11)

Field Sample Identification			WW-010306-0900	WW-030306-1100	WW-140306-1600	WW-150306-1700	WW-1600306-1700
Date Collected			03/02/06	03/03/06	03/14/06	03/15/06	03/16/06
Matrix			Water	Water	Water	Water	Water
Analyte/Methods (Units)							
pH	Method E150.1	N/A	7	7.3	7.3	7.6	8.6
Suspended Solids	Method E160.2	mg/L	ND	ND	ND	ND	ND
Oil/Grease	Method E1664	mg/L	1.4 T	4.1 T	16.2 JD	9.9 TD	<5.0
Cyanide	Method E335.4	mg/L	<0.01	<0.01	0.0059 T	<0.01	<0.01
Total Organic Carbon	Method E415.1	mg/L	-	-	-	-	-
Biologic oxygen demand, Five Day	Method E405.1	mg/L	61.7	87.6	258	108	41.2
COD - Chemical oxygen demand	Method E410.4	mg/L	515	333	606 D	539 D	443

- Not Analyzed

mg/l milligrams per liter.

Bold Bolded result indicates positively identified compound.

N/A Not applicable.

D Sample dilution required for analysis; reported values reflect the dilution.

J Data are estimated due to associated quality control data.

ND Not detected

T Analyte was positively identified but the reported concentration is estimated; reported concentration is less than the reporting limit, but greater than the method detection limit.

TABLE 34

WATER QUALITY PARAMETERS SAMPLE DATA SUMMARY
DEMONSTRATION TESTING AND FULL-SCALE OPERATION OF THE BIOGENESIS SEDIMENT DECONTAMINATION PROCESS
KEASBEY, NEW JERSEY
(Page 9 of 11)

Analyte/Methods (Units)	Field Sample Identification		WW-170306-1400	WW-21036-1800	WWC1-220306-1025	WW-300306-1300	WW-070406-1530
	Date Collected	Matrix	03/17/06 Water	03/21/06 Water	03/22/06 Water	03/30/06 Water	04/07/06 Water
pH	Method E150.1	N/A	8.8	8.8	6.6	8.2	7.0
Suspended Solids	Method E160.2	mg/L	10.4	-	-	ND	ND
Oil/Grease	Method E1664	mg/L	<5.0	-	-	<5.0	6.8
Cyanide	Method E335.4	mg/L	<0.01	-	-	0.005 T	0.014
Total Organic Carbon	Method E415.1	mg/L	-	-	-	-	-
Biologic oxygen demand, Five Day	Method E405.1	mg/L	67.4	-	-	93.4	89.4
COD - Chemical oxygen demand	Method E410.4	mg/L	67.4	-	-	191	152 D

- Not Analyzed

mg/l milligrams per liter.

Bold Bolded result indicates positively identified compound.

N/A Not applicable.

D Sample dilution required for analysis; reported values reflect the dilution.

J Data are estimated due to associated quality control data.

ND Not detected

T Analyte was positively identified but the reported concentration is estimated; reported concentration is less than the reporting limit, but greater than the method detection limit.

TABLE 34

WATER QUALITY PARAMETERS SAMPLE DATA SUMMARY
DEMONSTRATION TESTING AND FULL-SCALE OPERATION OF THE BIOGENESIS SEDIMENT DECONTAMINATION PROCESS
KEASBEY, NEW JERSEY
(Page 10 of 11)

Field Sample Identification			WW-120406-1000	WW-200406-1400	WW-260406-1000	WW-040506-1100	WW-120506-1100
Date Collected			04/12/06	04/20/06	04/26/06	05/04/06	05/12/06
Matrix			Water	Water	Water	Water	Water
Analyte/Methods (Units)							
pH	Method E150.1	N/A	6.8	7.5	7.8	8.8	-
Suspended Solids	Method E160.2	mg/L	ND	ND	9.2	10	ND
Oil/Grease	Method E1664	mg/L	10.7	<5.7	<5.1	<5.0	<5.2
Cyanide	Method E335.4	mg/L	<0.01	0.19	<0.01	<0.01	0.008 T
Total Organic Carbon	Method E415.1	mg/L	-	-	-	-	-
Biologic oxygen demand, Five Day	Method E405.1	mg/L	98.8	39.6	90	210	357
COD - Chemical oxygen demand	Method E410.4	mg/L	260	294	294	697	852 D

- Not Analyzed

mg/l milligrams per liter.

Bold Bolded result indicates positively identified compound.

N/A Not applicable.

D Sample dilution required for analysis; reported values reflect the dilution.

J Data are estimated due to associated quality control data.

ND Not detected

T Analyte was positively identified but the reported concentration is estimated; reported concentration is less than the reporting limit, but greater than the method detection limit.

TABLE 34

WATER QUALITY PARAMETERS SAMPLE DATA SUMMARY
DEMONSTRATION TESTING AND FULL-SCALE OPERATION OF THE BIOGENESIS SEDIMENT DECONTAMINATION PROCESS
KEASBEY, NEW JERSEY
(Page 11 of 11)

Field Sample Identification WW-170506-1100			
Date Collected 05/17/06			
Matrix Water			
Analyte/Methods (Units)			
pH	Method E150.1	N/A	7.6
Suspended Solids	Method E160.2	mg/L	27.6
Oil/Grease	Method E1664	mg/L	<5.2
Cyanide	Method E335.4	mg/L	<0.01
Total Organic Carbon	Method E415.1	mg/L	-
Biologic oxygen demand, Five Day	Method E405.1	mg/L	323
COD - Chemical oxygen demand	Method E410.4	mg/L	705

- Not Analyzed
mg/l milligrams per liter.
Bold Bolded result indicates positively identified compound.
N/A Not applicable.
D Sample dilution required for analysis; reported values reflect the dilution.
J Data are estimated due to associated quality control data.
ND Not detected
T Analyte was positively identified but the reported concentration is estimated; reported concentration is less than the reporting limit, but greater than the method detection limit.

APPENDIX C

DATA VALIDATION REPORT

FOR

DEMONSTRATION TESTING AND FULL-SCALE OPERATION
OF THE
BIOGENESISSM SEDIMENT DECONTAMINATION PROCESS

KEASBEY, NEW JERSEY

Prepared by:

MWH Americas, Inc.
Salt Lake City, Utah

TABLE OF CONTENTS

Section	Page
1.0 INTRODUCTION	7
2.0 DATA VERIFICATION RESULTS	11
2.1 Completeness Evaluation	11
2.2 Representativeness Evaluation	11
2.2.1 Standard Operating Procedure and QAPP Compliance Evaluation	12
2.2.2 Sample Preservation and Holding Time Evaluation	12
2.2.3 Sample Blanks Evaluation.....	12
2.2.4 Reporting Limits Evaluation	13
2.2.5 Field Duplicate Sample Evaluation	14
2.3 Accuracy Evaluation.....	14
2.3.1 Tune Standard Evaluation	15
2.3.2 Initial and Continuing Calibration Evaluation	15
2.3.3 Inductively Coupled Plasma Interference Check Samples Evaluation	16
2.3.4 Internal Standard Recoveries Evaluation	17
2.3.5 Surrogate Spike Recoveries Evaluation	18
2.3.6 Labeled Standard Evaluation.....	18
2.3.7 Ion Abundance Ratio Evaluation.....	19
2.3.8 Quantitation Ion Comaximization Evaluation.....	19
2.3.9 PCDPE Interference Evaluation	19
2.3.10 Matrix Spike/Matrix Spike Duplicate Samples Evaluation.....	19
2.3.11 Laboratory Control Sample/Laboratory Control Sample Duplicate Evaluation ..	21
2.4 Precision Evaluation	21
2.4.1 Matrix Spike/Matrix Spike Duplicate Samples Evaluation.....	22
2.4.2 Laboratory Control Sample/Laboratory Control Sample Duplicate Evaluation ..	22
2.4.3 Laboratory Replicate Sample Evaluation	22
2.4.4 Confirmation Column %D Evaluation	22
2.4.5 Serial Dilution Evaluation	23
2.4.6 Field Duplicate Sample Evaluation	23
2.5 Comparability Evaluation.....	23
3.0 DATA VERIFICATION SUMMARY.....	25
4.0 DATA USABILITY ASSESSMENT.....	27
4.1 Sample Collection and Analysis Completeness	27
4.2 Reporting Limits.....	28
4.3 “UJ”-Qualified and “R”-Flagged Data	28
4.4 Summary.....	31
REFERENCES.....	33
TABLES.....	35

ACRONYMS

ASTM	American Society of Testing and Materials
CCB	continuing calibration blank
CLP	contract laboratory program
CVS	calibration verification standard
DQOs	data quality objectives
GC/MS	gas chromatography/mass spectroscopy
ICAL	initial calibration
ICB	initial calibration blank
ICP	inductively coupled plasma
ICS	interference check sample
IDL	instrument detection limit
IS	internal standard
LCS	laboratory control sample
LCSD	laboratory control sample duplicate
MCLs	maximum contaminant levels
MDL	method detection limit
MS/MSD	matrix spike/matrix spike duplicate
NJNRDCSCC	New Jersey non-residential direct contact soil cleanup criteria
NJRDCSCC	New Jersey residential direct contact soil cleanup criteria
PAHs	polynuclear aromatic hydrocarbons
PARCC	precision, accuracy, representativeness, comparability, and completeness
%D	percent difference
%R	percent recovery
%RSD	percent relative standard deviation
PCBs	polychlorinated biphenyls
PCDPE	polychlorinated diphenyl ether
QAPP	quality assurance project plan
QC	quality control
RCRA	resource conservation and recovery act
RL	reporting limit
RPD	relative percent difference
RRF	relative response factor

ACRONYMS (CONTINUED)

SOPs	standard operating procedures
SPCCs	system performance check compounds
STL	Severn Trent Laboratory
SVOCs	semi-volatile organic compounds
TCLP	toxicity characteristic leaching procedure
TOC	total organic carbon
USEPA	United States Environmental Protection Agency

1.0 INTRODUCTION

This report presents the results of the verification of analytical data for solid samples collected during the BioGenesisSM Sediment Decontamination Demonstration Project in Keasbey, New Jersey, between December 2005 and January 2007. Severn Trent Laboratory (STL), of Pittsburgh, Pennsylvania, provided analytical services for this project (Select analyses were subcontracted to other STL laboratories located in Knoxville, Tennessee, and Burlington, Vermont). Battelle Applied Coastal and Environmental Services of Duxbury, MA provided analytical services for all split samples. The samples were analyzed using methods from the references listed below:

- United States Environmental Protection Agency (USEPA) *Test Methods for Evaluating Solid Waste, Physical/Chemical Methods SW-846* (Final Update III, December 1996)
- USEPA *Methods for the Determination of Inorganic Substances in Environmental Samples (EPA 100-400 Series)* (EPA/600R-93/100, August 1993)
- *American Society of Testing and Materials Methods* (ASTM), 1998. *Annual Book of ASTM Standards, 1998*.
- USEPA Region II – *Determination of Total Organic Carbon in Sediment (Lloyd Kahn Method)*, 1988.

Samples were analyzed for all or some of the following constituents:

- Percent solids by EPA 160.3 (EPA, 1996) (STL Pittsburgh, PA);
- Grain size by ASTM D4464 (STL Burlington, VT);
- Total organic carbon (TOC) by Lloyd Kahn (STL Burlington, VT);
- Metals by SW-846 6010B (EPA, 1996) (STL Pittsburgh, PA);
- Mercury by SW-846 7471A (EPA, 1996) (STL Pittsburgh, PA);
- Pesticides by SW-846 8081A (EPA, 1996) (STL Pittsburgh, PA);
- Polychlorinated biphenyl congeners (PCBs) by SW-846 8082 (EPA, 1996) (STL Pittsburgh, PA, and STL Knoxville, TN);
- Semi-volatile organic compounds (SVOCs) by SW-846 8270C (EPA, 1996) (STL Pittsburgh, PA);

-
- Polynuclear aromatic hydrocarbon compounds (PAHs) by SW-846 8270 SIM (EPA, 1996) (STL Pittsburgh, PA);
 - Chlorinated dioxins/furans by SW-846 8290 (EPA, 1996) (STL Knoxville, TN); and
 - Cyanide by SW9012A (EPA, 1996) (STL Burlington, VT).

The analytical results were evaluated against the project-specific data quality objectives (DQOs), which are quantitative and qualitative statements that specify data quality and are expressed in terms of precision, accuracy, representativeness, comparability, and completeness (PARCC) criteria. This data evaluation is presented in terms of the PARCC criteria and is based on the following:

- USEPA Contract Laboratory Program (CLP) National Functional Guidelines for Organic Data Review (October, 1999);
- USEPA CLP National Functional Guidelines for Inorganic Data Review (October, 2004);
- USEPA CLP National Functional Guidelines for Chlorinated Dioxin/Furan Data Review (September, 2005); and
- *The Quality Assurance Project Plan for the Demonstration Testing and Full-Scale Operation of the BioGenesisSM Sediment Decontamination Process in Keasbey, New Jersey*, hereafter referred to as the QAPP.

The analytical data were verified and qualified based on the results of all or some of the following data evaluation parameters or quality control (QC) samples as explained below:

- Laboratory compliance with laboratory standard operating procedures (SOPs) and the QAPP*;
- Sample preservation and holding time criteria*;
- Method and initial/continuing calibration blank (ICB/CCB) sample results;
- Reporting limits (RL)*;
- Initial calibration (ICAL);
- Continuing calibration verification standards (CVS);
- Interference check sample (ICS) results (inductively coupled plasma [ICP] metals only);
- Internal standards (IS) results (gas chromatography/mass spectroscopy [GC/MS] analyses only);

-
- Surrogate spike recoveries (organic analyses only)*;
 - Labeled standard evaluation (dioxin/furan analysis only)*;
 - Ion abundance ratios, quantitation ion comaximization, and polychlorinated diphenyl ether (PCDPE) interference (dioxin/furan analysis only);
 - Matrix spike/matrix spike duplicate (MS/MSD) samples*;
 - Laboratory control sample/laboratory control sample duplicate (LCS/LCSD) results*;
 - Laboratory replicate results*;
 - Confirmation column results (pesticide and PCBs only)*; and
 - Serial dilution results (metals only)*.

Full verification, or data evaluated on all listed criteria, was performed on data collected through May 5, 2006 which is 95% of all the data and 99.9% of that data was usable. The same quality is expected for the remainder of the data, therefore, only the criteria with an asterisk were evaluated for data collected after May 5, 2006.

The following discussions focus primarily on how the data were verified, data that have significant associated QC problems (i.e., rejected data), and analytical method or QAPP deviations. Data qualified due to the data verification are presented in Table 1. Quality control parameters outside acceptance criteria that did not result in data qualification are presented in Table 2. The complete data set is included in Appendix C to the Project Report.

2.0 DATA VERIFICATION RESULTS

2.1 Completeness Evaluation

Sampling Completeness. All samples were collected as scheduled. Sampling completeness for this project is 100 percent.

Analytical Completeness. Analytical completeness was evaluated using the following equation:

$$Completeness = \left(\frac{\text{Number of valid data}}{\text{Total number of measurements}} \right) \times 100 \quad \text{Eq. 1}$$

Where,

The number of valid data points is the total number of valid analytical measurements based on the precision, accuracy, and holding time evaluation.

All samples were analyzed according to the QAPP. Based on the results of the data verification described in the following paragraphs, all data were considered valid as qualified, with the exception of all PAH results for sample “WS-040106-1400”. Analytical completeness is 99.9 % for this project.

2.2 Representativeness Evaluation

Definition. Representativeness is a qualitative expression of the degree to which sample data accurately and precisely represent a characteristic of a population, a sampling point, or an environmental condition. Representativeness is maximized by ensuring that, for a given project, the number and location of sampling points and the sample collection and analysis techniques are appropriate for the specific investigation and the sampling and analysis program provides information that reflects true site conditions. Laboratory data were evaluated for representativeness by assessing the following:

- Laboratory compliance with laboratory SOPs and the QAPP;
- Sample preservation and holding time criteria;

-
- Method blank and ICB/CCB sample results;
 - RLs; and
 - Field duplicates.

2.2.1 Standard Operating Procedure and QAPP Compliance Evaluation

Based on the data verification, all samples were analyzed following the QC criteria specified in the QAPP and in accordance with the analytical methods and laboratory SOPs.

2.2.2 Sample Preservation and Holding Time Evaluation

Temperature blanks were included with each sample cooler for measurement upon receipt at the laboratory to assess whether the samples met temperature requirements. All samples received at the laboratory were within acceptance criteria and are considered representative.

Holding time reflects the length of time after sample collection that a sample or extract remains representative of environmental conditions. Depending on the analysis, one or two holding times were evaluated. For those analyses that did not require sample extraction, the length of time between sample collection and sample analysis was evaluated. For analyses that required sample extraction before analysis, the length of time from sample collection to sample extraction and the length of time from sample extraction to sample analysis were evaluated. Holding times were compared to standard method-specific holding times listed in the QAPP. Data for samples that were extracted and analyzed within holding time criteria were considered representative. For samples that were extracted or analyzed outside of holding time criteria, the sample data were qualitatively evaluated to determine the potential effect of the holding time exceedence on sample representativeness. Samples that were extracted and/or analyzed outside holding-time criteria are listed in Table 1 with “HT” as the QC type.

2.2.3 Sample Blanks Evaluation

Method blank and ICB/CCB results were used to assess representativeness for this project. The following criteria were used to assess the sample blanks:

- **Uncommon Laboratory Contaminants.** If a target analyte was detected in a blank and in an associated sample and the concentration of the analyte in the sample was less than five times the concentration detected in the blank, the analyte detected in the sample

datum was qualified with a “UB” flag to indicate the analyte is considered not detected. If the concentration of a target analyte in a sample was greater than five times the concentration detected in an associated blank, the sample datum was qualified with a “B” flag to indicate that a measurable concentration of a target analyte was detected in an associated blank.

- **Common Laboratory Contaminants.** If a target analyte was detected in a blank and in an associated sample and the concentration of the analyte in the sample was less than 10 times the concentration detected in the blank, the analyte detected in the sample was qualified with a “UB” flag to indicate the analyte is considered not detected. If the concentration of a target analyte in a sample was greater than 10 times the concentration detected in an associated blank, the sample datum was qualified with a “B” flag to indicate that a measurable concentration of a target analyte was detected in an associated blank.

Method Blank Samples. A method blank contains all the reagents used in the processing of samples and is carried through the complete analytical procedure used for the samples. Sample data that were qualified due to method blank data are listed in Table 1 with “MB” as the QC type. Analytes detected in method blanks that were not detected in an associated sample are listed in Table 2 with “MB” as the QC type.

ICC/CCB Sample Evaluation. ICB/CCB samples were analyzed with each sample batch for methods SW-846 6010B (ICP) and SW-846 7471A, to determine whether analytes of concern were introduced into samples during analysis by the laboratory. The ICB/CCB samples for ICP analysis consist of reagent water acidified to the same acidity of the standards and samples. The same criteria that were used to evaluate the sample blanks described previously were used to evaluate the ICB/CCB and associated sample data. No sample data were qualified due to ICB results. Analytes detected in the ICB/CCB that were not detected in an associated sample are listed in Table 2 with “ICB” as the QC type. Sample data that were qualified due to CCB data are listed in Table 1 with “CCB” as the QC type.

2.2.4 Reporting Limits Evaluation

Reporting Limits. The RL is the lowest concentration that can be reliably achieved within limits of precision and accuracy during routine instrument operating conditions and is based on the method detection limit (MDL) for each analyte – MDLs, and thus the RLs, are instrument and laboratory specific. For this project, all sample data were reported to their respective RLs with the following exception. For non-detect data, if an RL was greater than the New Jersey residential direct contact soil cleanup criteria (NJRDCSCC), the non-detect analytes were reported to their respective MDLs to achieve the lowest possible sample results and to try to meet the NJRDCSCC. The results reported to the MDL are italicized in the results tables.

2.2.5 Field Duplicate Sample Evaluation

Field Duplicates. Field duplicate samples were collected and analyzed to evaluate sampling and analytical representativeness. Because representativeness is affected by several variables including sample heterogeneity, sample collection procedures, sample preparation, and sample analysis, the results of field duplicates were used as additional evidence to support data quality rather than as a basis for accepting or rejecting the data.

The relative percent difference (RPD) was calculated only for those analytes that were detected above the RL in both the environmental and field duplicate samples. A comparison of the actual sample results and the RPDs indicate good agreement between the parent sample and its respective duplicate. Field duplicates with RPDs greater than 35% are listed in Table 2 with “FD” as the QC type.

2.3 Accuracy Evaluation

Definition. Accuracy is a measure of the level of agreement between a measurement and a known true value. Accuracy is evaluated by percent recovery (%R), which is calculated using the following equation:

$$\%R = \left(\frac{A - B}{C} \right) \times 100 \quad \text{Eq. 2}$$

Where,

A = the measured concentration of the spiked analyte in a spiked sample,

B = the measured concentration of the spiked analyte in an unspiked sample, and

C = the concentration of the analyte used for spiking.

Laboratory accuracy was evaluated using instrument tune results, ICAL and CVS results, ICS results (metals only), IS results (GC/MS analyses only), surrogate spike recoveries (organic analyses only), MS/MSD spiking analyte recoveries, LCS/LCSD spiking analyte recoveries, and labeled standard recoveries (dioxin/furan analysis only). In addition, for dioxin/furan analysis only, laboratory accuracy was also evaluated by reviewing ion abundance ratios, quantitation ion comaximization, and PCDPE interference.

2.3.1 Tune Standard Evaluation

For GC/MS methods, the analytical instruments must be tuned to demonstrate that the instrument is functioning such that it will detect the compounds of interest during analysis. Sample analysis can not proceed unless the tune standard criteria are met; otherwise, sample data are “R”-flagged to indicate the data are not usable. In addition, samples must be analyzed within twelve hours of the instrument tune standard. Samples analyzed outside the twelve-hour window are flagged with an “R” to indicate the data are not usable. All instrument tunes were in control for all analyses. Sample data analyzed outside the twelve-hour window are listed in Table 1 with “TUNE” as the QC type.

2.3.2 Initial and Continuing Calibration Evaluation

The ICAL and CVS were analyzed prior to and during sample analysis, respectively as specified by the analytical method. The ICAL is used to demonstrate linearity of instrument calibration, and the CVS is used to assess whether the ICAL remains valid. The ICAL and CVS results were evaluated against the method-specific QC criteria. If either the ICAL or the CVS QC criteria were not met, the data for all samples associated with the ICAL or CVS were qualified as follows:

- **ICAL Percent Relative Standard Deviation (%RSD) Outside Acceptance Criteria.** If the %RSD was outside the acceptance criterion, the calibration curve was evaluated to determine which standard caused the non-conformance. If the lowest level of the calibration curve was not the cause of the non-conformance and the laboratory demonstrated that the RL was met, non-detect data were not qualified. For detected analytes where the %RSD exceeded the acceptance criterion, the data were qualified with a “J” flag to indicate the data are estimated.
- **ICAL Average Relative Response Factor (RRF) Outside Acceptance Criteria (GC/MS Analysis Only).** If the RRF is outside acceptance criterion for system performance check compounds (SPCCs) (refer to the QAPP for method specific criteria or the acceptance criteria of <0.05 for non-SPCC compounds), the sample data were qualified as follows. If the analytes were not detected in the associated samples, the sample results were “R”-flagged to indicate the data are not usable. If the corresponding analytes were detected in the associated samples, the sample results were qualified with a “J” flag to indicate the data are estimated.
- **ICAL Coefficient of Determination (r or r^2) Outside Acceptance Criteria.** If linear regression was used for calibration and r or r^2 was outside the method respective acceptance criteria of >0.995 or >0.990, respectively, the sample data were qualified as follows. If the analytes were not detected in the associated samples, the sample results were qualified with a “UJ” flag to indicate possible false negatives. If the corresponding

analytes were detected in the associated samples, the sample results were qualified with a “J” flag to indicate the data are estimated.

- **CVS Percent Difference (%D) Outside Acceptance Criteria.** The CVS %D outside acceptance criteria indicates a potential bias during sample analysis. If the CVS %D was outside acceptance criterion, data for analytes that were detected in the samples associated with an outside-control CVS were qualified with a “J” flag, indicating the data are estimated.
- **The CVS Average RRF was Below Acceptance Criteria.** If the CVS average RRF was outside the acceptance criterion of <0.05 (for SVOCs, PAHs, and dioxins/furans only), the sample data were qualified as follows. If the analytes were not detected in the associated samples, the sample results were “R”-flagged to indicate the data are not usable. If the corresponding analytes were detected in the associated samples, the sample results were qualified with a “J” flag to indicate the data are estimated.

Sample data that were qualified due to initial calibration data outside acceptance criteria are presented in Table 1 with “ICAL” as the QC type. Sample data associated with initial calibration data outside acceptance criteria that did not result in data qualification are presented in Table 2 with “ICAL” as the QC type. Sample data that were qualified due to CVS data outside acceptance criteria are presented in Table 1 with “CVS” as the QC type. Sample data associated with CVS data outside acceptance criteria that did not result in data qualification are presented in Table 2 with “CVS” as the QC type.

2.3.3 Inductively Coupled Plasma Interference Check Samples Evaluation

The ICP ICS verifies the laboratory inter-element and background correction factors. The following criteria were used to assess the results of the ICSs. No sample data were qualified if the percent recovery of the ICS for an analyte was greater than 120 percent and the sample results were less than the instrument detection limit (IDL). If the percent recovery of an ICS for an analyte was greater than 120 percent, or between 50 and 79 percent and the sample results were greater than the IDL, the sample data were qualified with a “J” flag to indicate the data are estimated. If the percent recovery of the ICS for an analyte was between 50 and 79 percent and the sample results were less than the IDL, the sample data were qualified with a “UJ” flag to indicate possible false negatives. If the percent recovery of an ICS for an analyte was less than 50 percent, the sample data were “R”-flagged to indicate that the data are unusable. The ICS results were in control for all analyses.

2.3.4 Internal Standard Recoveries Evaluation

Internal standards are used to assess accuracy and to determine the concentration of target analytes in samples for SVOC and PAH analyses. Internal standards are spiked in the sample after sample preparation/extraction, but prior to analysis.

Analyte concentration is determined using the following equation:

$$C_s = \left(\frac{A_s \times C_{IS}}{A_{IS} \times RF} \right) \quad \text{Eq. 3}$$

Where,

C_s = concentration of the analyte or surrogate,

A_s = peak area (or height) of the analyte or surrogate,

C_{IS} = concentration of the IS,

A_{IS} = area of the IS, and

RF = average response factor of calibration curve.

Accuracy was assessed by comparing the IS recovery to the control limits established by the method. The following criteria were used to evaluate IS data:

- **Internal Standard Recovery Below Acceptance Criteria.** If the IS recovery was below 50 percent, non-detected analytes associated with the IS were qualified with a “UJ” flag, indicating possible false negatives. Detected analytes were qualified with a “J” flag, indicating the data are estimated.
- **Internal Standard Recovery Above Acceptance Criteria.** If the IS recovery was above 200 percent, undetected analytes were not qualified. Detected compounds were qualified with a “J” flag, indicating the data are estimated.

Sample data that were qualified due to IS data outside acceptance criteria are presented in Table 1 with “IS” as the QC type.

2.3.5 Surrogate Spike Recoveries Evaluation

Surrogate spike recoveries were used to evaluate the accuracy of the analytical data and to monitor laboratory control procedures for organic analyses. Samples were spiked with surrogate compounds according to laboratory SOPs. The surrogate spike recovery data were evaluated using the acceptance criteria outlined in the QAPP and as listed below:

- **Surrogate Recoveries Below the Lower Acceptance Criteria.** Surrogate recoveries below the acceptance criteria indicate a potential low bias during sample analysis. Therefore, if the number of surrogate failures exceeded the method allowable maximum and analytes associated with the surrogates were not detected in the sample, the sample results were qualified with a “UJ” flag, indicating possible false negatives. If analytes associated with the low surrogate recoveries were detected in the sample, the sample results were qualified with a “J” flag to indicate the data are estimated.
- **Surrogate Recoveries Outside the Upper Acceptance Criteria.** Surrogate recoveries above the acceptance criteria indicate a potential high bias during sample analysis. Therefore, if the number of surrogate failures exceeded the method allowable maximum and analytes associated with the surrogates were not detected in the sample, the sample results were not qualified. If the analytes associated with the high surrogate recoveries were detected in the sample, the sample results were qualified with a “J” flag to indicate the data are estimated.
- **High and Low Surrogate Exceedences for the Same Sample.** Bias cannot be determined if recovery of one surrogate is above and is below the acceptance criteria. Therefore, if the number of surrogate failures exceeded the method allowable maximum and analytes associated with the surrogates were not detected in the sample, the sample results were not qualified. If the analytes associated with the failed surrogates were detected in the sample, the sample results were qualified with a “J” flag to indicate the data are estimated.

All surrogate recoveries were in control for all analyses with the following exception. Because of high analyte concentrations in the sediment samples requiring sample dilution, the surrogates were not recovered for some pesticide, PAH, and SVOC analyses.

2.3.6 Labeled Standard Evaluation

For dioxin/furan analysis the standards are labeled with carbon-13 and are spiked into the sample before extraction. The labeled standards function as both a surrogate and internal standard. The labeled standard recoveries were evaluated using the acceptance criteria outlined in the QAPP. The same data qualification procedures used for surrogate spike results were used for labeled standards with the following exception, specific compounds are assigned to each labeled

standard and data only for those compounds associated with the labeled standard outside the acceptance criteria were qualified. All labeled standard recoveries were within acceptance criteria.

2.3.7 Ion Abundance Ratio Evaluation

For dioxin/furan analysis, positive analyte identification requires that the major ions for that particular dioxin/furan be present within method-specified ratios. If the ion ratio was outside the method criteria for a target analyte in a sample, the data were qualified with a “J” flag indicating the data are estimated. Sample data associated with ion abundance ratios outside acceptance criteria are listed in Table 1 with “IAR” as the QC type.

2.3.8 Quantitation Ion Comaximization Evaluation

For dioxin/furan analysis, positive analyte identification requires that the major ions for that particular dioxin/furan peaks comaximize within two seconds of each other. If the major ions comaximized outside the method criteria for a target analyte in a sample, the data were qualified with a “J” flag indicating the data are estimated. Sample data associated with comaximization criteria outside acceptance criterion are listed in Table 1 with “CMC” as the QC type.

2.3.9 PCDPE Interference Evaluation

For furan analysis, positive analyte identification requires the absence of PCDPE above a signal to noise ratio of 2.5 and within the retention-time window of target analyte furans. If the PCDPE isomer peak had a signal to noise ratio greater than or equal to 2.5 and was within ± 2 seconds of a target analyte retention time window, the data were qualified with a “J” flag indicating the data are estimated. Sample data associated with PCDPE interference are listed in Table 1 with “PDE” as the QC type.

2.3.10 Matrix Spike/Matrix Spike Duplicate Samples Evaluation

Site specific MS/MSD samples were analyzed to assess accuracy and to identify possible adverse matrix effects. These samples were spiked with target analytes according to EPA guidance before extraction or analysis. The percent recoveries of the spiked analytes were compared to the QAPP-established QC limits. The following criteria were used to evaluate the MS/MSD samples:

-
- **MS/MSD Recovery Below Acceptance Criteria.** Matrix spike analytes below the acceptance criteria indicated a potential low bias during sample analysis. Therefore, if corresponding analytes were not detected in the parent sample, the sample data were qualified with a “UJ” flag indicating possible false negatives. If corresponding analytes were detected in the parent sample, the data were qualified with a “J” flag indicating the data are estimated.
 - **MS/MSD Recovery Above Acceptance Criteria.** Matrix spike/matrix spike duplicate recoveries above the acceptance criteria indicate a potential high bias during sample analysis. Therefore, if corresponding analytes were not detected in the parent sample, data were not qualified. If corresponding analytes were detected in the parent sample, data were qualified with a “J” flag indicating the data are estimated.
 - **High Analyte Concentration in Parent Sample.** If the concentration in the parent sample was more than four times the spiked analyte concentration, the overall change in the MS/MSD concentration is not significant enough for the instrument to detect the spiked analyte. Therefore, if the MS/MSD recoveries were outside the acceptance criteria, no data were qualified.
 - **High and Low MS/MSD Exceedences.** Bias cannot be determined if a spike recovery is above the acceptance criterion in the MS and below the acceptance criterion in the MSD or vice versa. Therefore, the following procedures were used to validate parent sample data. If the analyte was not detected in the parent sample for the MS/MSD analytes that were outside acceptance criteria, the sample data were not qualified. If the analyte was detected in the parent sample for the MS/MSD analytes that were outside acceptance criteria, the sample data were qualified with a “J” flag, indicating the data are estimated.
 - **Only the MS or MSD Outside Acceptance Criteria.** If a target analyte was outside acceptance criteria in only the MS or MSD, and the RPD (discussed later in the precision section) was within acceptance criterion, the following criteria were used to evaluate the MS/MSD data. If a spike recovery in an MS or MSD sample was outside the acceptance criteria and the spike recovery in the other sample (MS or MSD) was just inside the acceptance criteria (at the same end of acceptance criteria range), the data were treated as if both the MS and MSD recoveries were outside the acceptance criteria. The parent sample datum was qualified using the criteria for MS/MSD recoveries above or below the acceptance criteria as described previously. If an MS or MSD spike recovery was outside the acceptance criteria but the spike recovery in the other sample (MS or MSD) was well within the acceptance criteria (near the middle of the range), it was assumed that the recovery outside the acceptance criteria was an anomaly, and not indicative of the sample media, therefore, no parent sample data were qualified.

Sample data that were qualified due to MS/MSD data outside acceptance criteria are presented in Table 1 with “MS” and/or “MSD” as the QC type. Matrix spike/matrix spike duplicate data outside acceptance criteria that did not result in qualified data are presented in Table 2 with “MS” and/or “MSD” as the QC type.

2.3.11 Laboratory Control Sample/Laboratory Control Sample Duplicate Evaluation

Laboratory control samples/laboratory control sample duplicates were analyzed to assess accuracy in the absence of matrix effects. Sand was spiked with target analytes according to the QAPP before extraction or analysis. The percent recoveries of the spiked analytes were compared to the QAPP-established QC limits. The same criteria used to evaluate the MS/MSD samples described previously were used to evaluate the LCS/LCSD except that an entire batch would be qualified if an LCS and/or LCSD result was outside acceptance criteria. Sample data that were qualified due to LCS/LCSD data outside acceptance criteria are presented in Table 1 with “LCS” and/or “LCSD” as the QC type. Laboratory control sample/LCSD data outside acceptance criteria that did not result in qualified data are presented in Table 2 with “LCS” and/or “LCSD” as the QC type.

2.4 Precision Evaluation

Definition. Precision evaluation measures the reproducibility of measurements under a given set of conditions, and is expressed as RPD:

$$RPD = \left(\frac{|A - B|}{(A + B) \div 2} \right) \times 100 \quad \text{Eq. 4}$$

Where,

A and B = the reported concentrations for sample replicate analyses.

Alternatively, precision evaluation can also be expressed as % D:

$$\%D = \left(\frac{C_c - E_c}{E_c} \right) \times 100 \quad \text{Eq. 5}$$

Where,

C_c = calculated concentration, and

E_c = expected concentration.

Laboratory precision was evaluated using the MS/MSD RPD results, LCS/LCSD RPD results, laboratory replicate RPD results, confirmation column %D results (pesticide and PCB analyses

only), and the serial dilution %D results (metals analysis only). The criteria described in the following paragraphs were used to evaluate precision for MS/MSD samples, LCS/LCSD samples, laboratory replicates, serial dilutions, and field duplicates.

2.4.1 Matrix Spike/Matrix Spike Duplicate Samples Evaluation

If the RPD between the MS and MSD exceeded the acceptance criteria, corresponding analytes detected in the associated samples were qualified with a “J” flag, indicating the data are estimated. Sample data that were qualified due to MS/MSD RPD data outside acceptance criteria are listed in Table 1 with “RPD” as the QC type. Sample data associated with MS/MSD RPD data outside acceptance criteria that did not result in data qualification are listed in Table 2 with “RPD” as the QC type.

2.4.2 Laboratory Control Sample/Laboratory Control Sample Duplicate Evaluation

If the RPD between the LCS and LCSD exceeded the acceptance criteria, corresponding analytes detected in the associated samples were qualified with a “J” flag, indicating the data are estimated. Sample data that were qualified due to LCS/LCSD RPD data outside acceptance criteria are listed in Table 1 with “RPD” as the QC type.

2.4.3 Laboratory Replicate Sample Evaluation

If the RPD between the parent sample and the laboratory replicate exceeded the acceptance criteria, corresponding analytes detected in the parent samples were qualified with a “J” flag, indicating the data were estimated. All laboratory replicate results were within acceptance criteria.

2.4.4 Confirmation Column %D Evaluation

Pesticide and PCB results were confirmed using two dissimilar columns, one column was designated as the primary column and the other as the confirmation column. If the %D between the primary and secondary column results was greater than the method-specified criterion of 40%, the sample data were qualified with a “J” flag, indicating the data are estimated. Sample data that were qualified due to confirmation column %D data outside acceptance criterion are listed in Table 1 with “CONF” as the QC type.

2.4.5 Serial Dilution Evaluation

Serial dilutions are performed to assess the possibility of interferences during metals analysis. A serial dilution is only performed when the concentration of metals in the sample is 10 times greater than the reporting limit. For this project, serial dilutions were performed on site-specific samples. The following criteria were used to assess the results of the serial dilution. If the percent difference between the parent sample and the serial dilution result was greater than 10 percent, interference was suspected and the sample data were qualified with a “J” flag, indicating the data are estimated. Sample data that were qualified due to serial dilution data outside acceptance criterion are listed in Table 1 with “SLD” as the QC type

2.4.6 Field Duplicate Sample Evaluation

As discussed previously, field duplicate samples were collected and analyzed to evaluate sampling and analytical representativeness. Because representativeness is affected by several variables including sample heterogeneity, sample collection procedures, sample preparation, and sample analysis, the results of field duplicates were used as additional evidence to support data quality rather than as a basis for accepting or rejecting the data.

The relative percent difference (RPD) was calculated only for those analytes that were detected above the RL in both the environmental and field duplicate samples. A comparison of the actual sample results and the RPDs indicate good agreement between the parent sample and its respective duplicate. Field duplicates with RPDs greater than 35% are listed in Table 2 with “FD” as the QC type.

2.5 Comparability Evaluation

Comparability is a qualitative parameter that expresses the confidence that one data set may be compared to another data set. For this project, sample collection and analysis followed standard methods and the data were reported using standard units of measure. In addition, QC data for this project indicate the data are comparable. Therefore, the data from this project should be comparable to data collected from these sites, processed under the same conditions, using similar sample collection and analytical methodology.

3.0 DATA VERIFICATION SUMMARY

Precision. Based on the MS/MSD, LCS/LSD, laboratory replicate, confirmation column, serial dilution, field duplicate results, the sample data are precise as qualified.

Accuracy. Based on the results of the ICAL, CVS, ICS, IS, surrogate spike, labeled standard, ion ratio, comaximization, PCDPE interference, MS/MSD, and LCS/LCSD results, the sample data are accurate as qualified.

Representativeness. Based on the results of the sample preservation and holding time evaluation; method blank sample data; ICB/CCB, and field duplicate results, the sample data for this project are considered representative of the site as qualified.

Comparability. Standard methods of sample collection and standard units of measure were used during this project. The analyses performed by the laboratory were in accordance with current EPA methodology. Therefore, the data from this project should be comparable to data collected at these ~~sediment~~ sources, processed under the same conditions, using similar sample collection and analytical methodology.

Completeness. Based on the results of the data verification, all data were considered valid as qualified with the exception of all PAH results for sample “WS-040106-1400”. Sampling completeness was 100 percent and analytical completeness was 99.9 percent.

4.0 DATA USABILITY ASSESSMENT

The data usability evaluation is a qualitative assessment that is conducted to evaluate whether the verified data are of sufficient quality to support the project objectives (that is, end use). The objectives for this project were to demonstrate the BioGenesisSM Sediment Decontamination process.

The data usability evaluation was conducted by assessing the following:

- Were all data that were scheduled for this project collected?
- Did the sample results RLs or MDLs meet their respective regulatory levels (that is, will data that were collected support evaluation of presence or absence of contaminants below the regulatory levels)?
- Were data for this project R-flagged as unusable? If so, will these data impact the decision-making process (that is, will these data affect conclusions regarding site characterization)?
- Did data that were qualified with a “UJ” flag as a possible false negative impact the decision-making process (that is, will these data affect conclusions regarding site characterization)?
- Was the data completeness goal for this project met (that is, were sufficient data of sufficient quality collected to meet the project completeness goal)?

Based on the results of the data verification, the data collected for demonstration of the BioGenesisSM Sediment Decontamination Process are of sufficient quantity and quality to meet the project objectives. The remainder of this section presents the results of the data usability evaluation.

4.1 Sample Collection and Analysis Completeness

Sample Collection Completeness. All samples that were scheduled for this project were collected as scheduled. The sampling completeness for this project was 100 percent.

Sample Analysis Completeness. Analytical completeness was evaluated on a per-analyte basis using the following equation:

$$\text{Completeness} = \left(\frac{\text{Number of valid data}}{\text{Total number of measurements}} \right) \times 100 \quad \text{Eq. 6}$$

Where,

The number of valid data points is the total number of valid analytical measurements based on the precision, accuracy, preservation, and holding time evaluation.

Based on the results of the data verification, all data are considered valid as qualified with the exception of all PAH results for sample “WS-040106-1400”. Analytical completeness was 99.9 percent, which meets the project completeness goal.

4.2 Reporting Limits

Every effort was made to analyze the samples using the best available methods so that the regulatory levels for this project were met. The following criteria were used for data reporting:

All sample results were reported to the RL. If there were no target analyte detections in the sample, the sample results were reported as <RL value with the following exception. For non-detect data, if an RL was greater than the NJRDCSCC, the non-detect analytes were reported to their respective MDLs to achieve the lowest possible sample results and to try to meet the NJRDCSCC.

- If a target analyte was detected between the MDL and RL, the result was qualified with a “T” flag to indicate the data were estimated and reflect a value between the MDL and RL.

4.3 “UJ”-Qualified and “R”-Flagged Data

The two data flags that are of particular importance regarding data validation are “UJ”, which indicates a possible false negative, and “R”, which indicates the data may not be usable. The following paragraphs discuss the implications of R-flagged and UJ-qualified data to data usability.

When select QC criteria are outside acceptance criteria indicating low bias, sample data for non-detect analytes were qualified with an “R” flag to indicate the data were unusable. Unusable data are listed in Table 1.

The R-flagged data are limited to the following analytes and samples:

- All PAH results for sediment sample “WS-040106-1400”. Because the sample was analyzed outside the twelve-hour instrument tune window, the data are unusable.

When QC criteria are outside acceptance criteria indicating low bias, sample data for non-detect analytes were qualified with a “UJ” flag to indicate the data were estimated as potential false negatives. Potential false negative data are listed in Table 1.

The UJ-qualified data are limited to the following SVOC analytes and samples:

- 1,4-Dichlorobenzene for sample “TS-211205-1715”, due to IS recoveries outside acceptance criteria.
- 1,4-Dichlorobenzene for samples “RS-030106-1600” and “WS-030206-1202”, due to MS recoveries outside acceptance criteria.
- 2,4,5-Trichlorophenol for sample “TS-211205-1715”, due to IS recoveries outside acceptance criteria.
- 2,4,5-Trichlorophenol for samples “TS-060406-1240” and “TS-170406-1745”, due to MS or MSD recoveries outside acceptance criteria.
- 2,4,6-Trichlorophenol for sample “TS-211205-1715”, due to IS recoveries outside acceptance criteria.
- 2,4,6-Trichlorophenol for samples “TS-060406-1240”, “TS-100406-1615”, “TS-170406-1745”, and “TS-200406-1635”, due to MS or MSD recoveries outside acceptance criteria.
- 2,4-Dinitrotoluene for sample “TS-211205-1715”, due to IS recoveries outside acceptance criteria.
- 2,4-Dinitrotoluene for sample “TS-200406-1635”, due to MS/MSD recoveries outside acceptance criteria.
- 2-Methylphenol (o-cresols) for samples “TS-270206-1350”, “TS-270206-1350 DRIED”, “TS-270206-1630”, and “TS-270206-1630 DRIED”, due to MS recoveries outside acceptance criteria.
- Benzo(k)fluoranthene for sample “WS-120406-1840”, due to MS/MSD recoveries outside acceptance criteria.
- 3/4-Methylphenol (m & p cresols) for sample “TS-211205-1715”, due to IS recoveries outside acceptance criteria.

-
- Dibenz(a,h)anthracene for samples “TS-100406-1615”, “TS-270206-1350”, “TS-270206-1350 DRIED”, and “WS-120406-1840”, due to MSD or MS/MSD recoveries outside acceptance criteria.
 - Fluorene for samples “WS-060206-1932” and “WS-120406-1840”, due to MS or MS/MSD recoveries outside acceptance criteria.
 - Hexachlorobenzene for sample “TS-211205-1715”, due to IS recoveries outside acceptance criteria.
 - Hexachlorobenzene for samples “TS-060406-1240”, “TS-100406-1615”, “TS-200406-1635”, and “WS-120406-1840”, due to MS or MS/MSD recoveries outside acceptance criteria.
 - Hexachlorobutadiene for samples “TS-211205-1715” and “WS-070206-1632”, due to IS recoveries outside acceptance criteria.
 - Hexachlorobutadiene for sample “WS-120406-1840”, due to MSD recovery outside acceptance criteria.
 - Hexachloroethane for sample “TS-211205-1715”, due to IS recoveries outside acceptance criteria.
 - Hexachloroethane for samples “RS-030106-1600”, “TS-010306-1705”, “TS-030306-1205”, “TS-060406-1240”, “TS-100406-1615”, “TS-140206-1331”, “TS-160206-1501”, “TS-170406-1745”, “TS-200406-1635”, “TS-270206-1350”, “TS-270206-1350 DRIED”, “TS-270206-1630”, “TS-270206-1630 DRIED”, “WS-020306-1710”, “WS-030206-1202”, “WS-030506-1640”, “WS-060206-1932”, “WS-120406-1840”, “WS-270406-1740”, and “WS-310106-1702”, due to MS/MSD recoveries outside acceptance criteria.
 - Indeno(1,2,3-c,d)pyrene for sample “WS-120406-1840”, due to MS/MSD recoveries outside acceptance criteria.
 - Naphthalene for sample “WS-070206-1632”, due to IS recoveries outside acceptance criteria.
 - Naphthalene for sample “WS-080206-1702”, due to MS/MSD recoveries outside acceptance criteria.
 - Nitrobenzene for samples “TS-211205-1715” and “WS-070206-1632”, due to IS recoveries outside acceptance criteria.
 - Pentachlorophenol for samples “PSS-030506-1600”, “RS-030506-1615”, “RS-120406-1815”, “STS-3-030506-1200”, “STS-4-030506-1400”, “TS-030506-1635”, “TS-120406-1835”, “WS-030506-1640”, and “WS-120406-1840”, due to LCS recoveries outside acceptance criteria.

-
- Pentachlorophenol for samples “TSS-010306-1705”, “TS-100406-1615”, “TS-230206-0930”, “TS-230206-0930 DRIED”, and “WS-120406-1840”, due to MS/MSD recoveries outside acceptance criteria.

4.4 Summary

In summary, the usability of the data package is 99.9% and the data are considered of sufficient quality to make informed decisions about the efficacy of the BioGenesisSM Sediment Decontamination Process demonstrated in Keasbey, New Jersey.

REFERENCES

- ASTM, 1998. American Society of Testing and Materials Methods, 1998. *Annual Book of ASTM Standards, 1998*.
- EPA, 1996. *Test Methods for Evaluating Solid Waste, Physical/Chemical Methods (SW-846)*, 3d ed., September 1986; Final Update III, December.
- EPA, 1993. *EPA 100-400 Series – Methods for the Determination of Inorganic Substances in Environmental Samples. EPA/600R 93-100*. U.S. Environmental Protection Agency, Office of Research and Development, Environmental Monitoring Systems Laboratory, Cincinnati, Ohio. August.
- EPA, 2004. *Contract Laboratory Program National Functional Guidelines for Inorganic Data Review. EPA 540-R-04-004* U.S. Environmental Protection Agency, Office of Superfund Remediation and Technology Innovation (OSRTI), Washington, DC. October.
- EPA, 2004. *Contract Laboratory Program National Functional Guidelines for Organic Data Review. EPA540/R-99/008*. U.S. Environmental Protection Agency, Office of emergency and Remedial response, Washington, DC. October.
- EPA, 2005. *Contract Laboratory Program National Functional Guidelines for Chlorinated Dioxin/Furan Data Review. EPA 540-R-05-001* U.S. Environmental Protection Agency, Office of Superfund Remediation and Technology Innovation (OSRTI), Washington, DC. September.
- Kahn, L. 1988. EPA Region II – *Determination of Total Organic Carbon in Sediment (Lloyd Kahn Method)*.
- MWH, 2005. *Quality Assurance Project Plan for the Demonstration Testing and Full-Scale Operations of the BioGenesisSM Sediment Decontamination Process in Keasbey, New Jersey, Draft Final*. MWH Americas, Inc. December.

TABLES

TABLE 1
DATA QUALIFIERS SUMMARY TABLE
DEMONSTRATION TESTING AND FULL-SCALE OPERATION OF THE BIOGENESIS SEDIMENT DECONTAMINATION PROCESS, KEASBEY, NEW JERSEY
 (Page1 of 188)

Location Identification	Sample Identification	Sample Date	Analysis	Analyte	Sample Result	Sample Units	QC Type	QC Result	QC Units	Qualifier	Bias	Comment
RS	RS-211205-1000	12/21/05	SW-846 6010B	Chromium, total	27 3	mg/kg	LB	0 12 T	mg/kg	B	None	Analyte detected in associated blank; sample concentration greater than five times the blank concentration
RS	RS-211205-1000	12/21/05	SW-846 6010B	Zinc	125	mg/kg	LB	0 77 T	mg/kg	B	None	Analyte detected in associated blank; sample concentration greater than five times the blank concentration
RS	RS-211205-1000	12/21/05	SW-846 8081A	Alpha-Chlordane	1 6 T	µg/kg	CONF	132 5	%	J	None	Datum is estimated, bias unknown; %D between primary and secondary GC columns outside acceptance criterion
RS	RS-211205-1000	12/21/05	SW-846 8081A	Beta endosulfan	1 6 T	µg/kg	CONF	142 9	%	J	None	Datum is estimated, bias unknown; %D between primary and secondary GC columns outside acceptance criterion
RS	RS-211205-1000	12/21/05	SW-846 8081A	p,p'-DDD	1 1 T	µg/kg	CONF	432 4	%	J	None	Datum is estimated, bias unknown; %D between primary and secondary GC columns outside acceptance criterion
RS	RS-211205-1000	12/21/05	SW-846 8082	2,2',3,4,5'-Pentachlorobiphenyl	4 2 D	µg/kg	CONF	87 1	%	J	None	Datum is estimated, bias unknown; %D between primary and secondary GC columns outside acceptance criterion
RS	RS-211205-1000	12/21/05	SW-846 8082	2,2',5-Trichlorobiphenyl	8 8 D	µg/kg	CONF	107 2	%	J	None	Datum is estimated, bias unknown; %D between primary and secondary GC columns outside acceptance criterion
RS	RS-211205-1000	12/21/05	SW-846 8082	2,4,5-Trichlorobiphenyl	8 3 D	µg/kg	CONF	121 5	%	J	None	Datum is estimated, bias unknown; %D between primary and secondary GC columns outside acceptance criterion
RS	RS-211205-1000	12/21/05	SW-846 8082	2-Chlorobiphenyl	6 4 TD	µg/kg	CONF	435 2	%	J	None	Datum is estimated, bias unknown; %D between primary and secondary GC columns outside acceptance criterion
RS	RS-211205-1000	12/21/05	SW-846 8290	1,2,3,4,6,7,8-Heptachlorodibenzo-p-dioxin	150	pg/g	LB	0 11 T	pg/g	B	None	Analyte detected in associated blank; sample concentration greater than five times the blank concentration
RS	RS-211205-1000	12/21/05	SW-846 8290	1,2,3,4,6,7,8-Heptachlorodibenzofuran	21	pg/g	LB	0 12 T	pg/g	B	None	Analyte detected in associated blank; sample concentration greater than five times the blank concentration
RS	RS-211205-1000	12/21/05	SW-846 8290	1,2,3,4,7,8,9-Heptachlorodibenzofuran	2 7 T	pg/g	LB	0 12 T	pg/g	B	None	Analyte detected in associated blank; sample concentration greater than five times the blank concentration
RS	RS-211205-1000	12/21/05	SW-846 8290	1,2,3,7,8,9-Hexachlorodibenzo-p-Dioxin	7 4 T	pg/g	LB	0 11 T	pg/g	B	None	Analyte detected in associated blank; sample concentration greater than five times the blank concentration
RS	RS-211205-1000	12/21/05	SW-846 8290	1,2,3,7,8,9-Hexachlorodibenzofuran	0 46 T	pg/g	IAR	1 78	N/A	J	None	Datum is estimated, bias unknown; ion abundance ratio outside acceptance criteria
RS	RS-211205-1000	12/21/05	SW-846 8290	1,2,3,7,8-Pentachlorodibenzofuran	2 4 T	pg/g	LB	0 063 T	pg/g	B	None	Analyte detected in associated blank; sample concentration greater than five times the blank concentration

TABLE 1
DATA QUALIFIERS SUMMARY TABLE
DEMONSTRATION TESTING AND FULL-SCALE OPERATION OF THE BIOGENESIS SEDIMENT DECONTAMINATION PROCESS, KEASBEY, NEW JERSEY
(Page 2 of 188)

Location Identification	Sample Identification	Sample Date	Analysis	Analyte	Sample Result	Sample Units	QC Type	QC Result	QC Units	Qualifier	Bias	Comment
RS	RS-211205-1000	12/21/05	SW-846 8290	2,3,4,6,7,8-Hexachlorodibenzofuran	1.5 T	pg/g	IAR	1.71	N/A	J	None	Datum is estimated, bias unknown; ion abundance ratio outside acceptance criteria
RS	RS-211205-1000	12/21/05	SW-846 8290	2,3,4,7,8-Pentachlorodibenzofuran	4.3 T	pg/g	LB	0.051 T	pg/g	B	None	Analyte detected in associated blank; sample concentration greater than five times the blank concentration
RS	RS-211205-1000	12/21/05	SW-846 8290	Octachlorodibenzo-p-dioxin	8700	pg/g	LB	0.47 T	pg/g	B	None	Analyte detected in associated blank; sample concentration greater than five times the blank concentration
RS	RS-211205-1000	12/21/05	SW-846 8290	Octachlorodibenzofuran	31	pg/g	LB	0.21 T	pg/g	B	None	Analyte detected in associated blank; sample concentration greater than five times the blank concentration
TS	TS-211205-1715	12/21/05	SW-846 8270 SIM	Phenanthrene	420	µg/kg	IS	<50		J	None	Datum is estimate, bias unknown; all IS area recoveries outside acceptance criteria
TS	TS-211205-1715	12/21/05	SW-846 6010B	Chromium, total	28.6	mg/kg	LB	0.12 T	mg/kg	B	None	Analyte detected in associated blank; sample concentration greater than five times the blank concentration
TS	TS-211205-1715	12/21/05	SW-846 6010B	Zinc	134	mg/kg	LB	0.77 T	mg/kg	B	None	Analyte detected in associated blank; sample concentration greater than five times the blank concentration
TS	TS-211205-1715	12/21/05	SW-846 8081A	Aldrin	1.2 T	µg/kg	CONF	322.8	%	J	None	Datum is estimated, bias unknown; %D between primary and secondary GC columns outside acceptance criterion
TS	TS-211205-1715	12/21/05	SW-846 8081A	Endrin ketone	0.61 T	µg/kg	CONF	60.5	%	J	None	Datum is estimated, bias unknown; %D between primary and secondary GC columns outside acceptance criterion
TS	TS-211205-1715	12/21/05	SW-846 8081A	Gamma-Chlordane	0.63 T	µg/kg	CONF	318.7	%	J	None	Datum is estimated, bias unknown; %D between primary and secondary GC columns outside acceptance criterion
TS	TS-211205-1715	12/21/05	SW-846 8082	2,2',3,4,5'-Pentachlorobiphenyl	2.2 D	µg/kg	CONF	99	%	J	None	Datum is estimated, bias unknown; %D between primary and secondary GC columns outside acceptance criterion
TS	TS-211205-1715	12/21/05	SW-846 8082	2,2',4,5,5'-Pentachlorobiphenyl	4.8 D	µg/kg	MSD	40	%	J	Low	Datum is estimated, possible low bias; MSD recovery outside acceptance criteria
TS	TS-211205-1715	12/21/05	SW-846 8082	2,2',5,5'-Tetrachlorobiphenyl	7.6 D	µg/kg	MS MSD	41 15	%	J	Low	Datum is estimated, possible low bias; MS/MSD recoveries outside acceptance criteria
TS	TS-211205-1715	12/21/05	SW-846 8082	2,3',4,4'-Tetrachlorobiphenyl	7.7 D	µg/kg	MS	44	%	J	Low	Datum is estimated, possible low bias; MS recovery outside acceptance criteria
TS	TS-211205-1715	12/21/05	SW-846 8082	2,4,5-Trichlorobiphenyl	4.6 D	µg/kg	CONF	109.1	%	J	None	Datum is estimated, bias unknown; %D between primary and secondary GC columns outside acceptance criterion
TS	TS-211205-1715	12/21/05	SW-846 8082	2-Chlorobiphenyl	6.3 TD	µg/kg	CONF	111.1	%	J	None	Datum is estimated, bias unknown; %D between primary and secondary GC columns outside acceptance criterion

TABLE 1
DATA QUALIFIERS SUMMARY TABLE
DEMONSTRATION TESTING AND FULL-SCALE OPERATION OF THE BIOGENESIS SEDIMENT DECONTAMINATION PROCESS, KEASBEY, NEW JERSEY
 (Page 3 of 188)

Location Identification	Sample Identification	Sample Date	Analysis	Analyte	Sample Result	Sample Units	QC Type	QC Result	QC Units	Qualifier	Bias	Comment
TS	TS-211205-1715	12/21/05	SW-846 8270C	1,4-Dichlorobenzene	<450	µg/kg	IS	<50		UJ	Low	Possible false negative; all IS area recoveries outside acceptance criteria
TS	TS-211205-1715	12/21/05	SW-846 8270C	2,4,5-Trichlorophenol	<450	µg/kg	IS	<50		UJ	Low	Possible false negative; all IS area recoveries outside acceptance criteria
TS	TS-211205-1715	12/21/05	SW-846 8270C	2,4,6-Trichlorophenol	<450	µg/kg	IS	<50		UJ	Low	Possible false negative; all IS area recoveries outside acceptance criteria
TS	TS-211205-1715	12/21/05	SW-846 8270C	2,4-Dinitrotoluene	<450	µg/kg	IS	<50		UJ	Low	Possible false negative; all IS area recoveries outside acceptance criteria
TS	TS-211205-1715	12/21/05	SW-846 8270C	2-Methylphenol (o-Cresol)	<450	µg/kg	IS	<50		UJ	Low	Possible false negative; all IS area recoveries outside acceptance criteria
TS	TS-211205-1715	12/21/05	SW-846 8270C	Acenaphthene	50 T	µg/kg	IS	<50		J	None	Datum is estimate, bias unknown; all IS area recoveries outside acceptance criteria
TS	TS-211205-1715	12/21/05	SW-846 8270C	Acenaphthylene	85 T	µg/kg	IS	<50		J	None	Datum is estimate, bias unknown; all IS area recoveries outside acceptance criteria
TS	TS-211205-1715	12/21/05	SW-846 8270C	Anthracene	200 T	µg/kg	IS	<50		J	None	Datum is estimate, bias unknown; all IS area recoveries outside acceptance criteria
TS	TS-211205-1715	12/21/05	SW-846 8270C	Benzo(a)anthracene	490	µg/kg	IS	<50		J	None	Datum is estimate, bias unknown; all IS area recoveries outside acceptance criteria
TS	TS-211205-1715	12/21/05	SW-846 8270C	Benzo(a)pyrene	580	µg/kg	IS	<50		J	None	Datum is estimate, bias unknown; all IS area recoveries outside acceptance criteria
TS	TS-211205-1715	12/21/05	SW-846 8270C	Benzo(b)fluoranthene	560	µg/kg	IS	<50		J	None	Datum is estimate, bias unknown; all IS area recoveries outside acceptance criteria
TS	TS-211205-1715	12/21/05	SW-846 8270C	Benzo(g,h,i)perylene	400 T	µg/kg	IS	<50		J	None	Datum is estimate, bias unknown; all IS area recoveries outside acceptance criteria
TS	TS-211205-1715	12/21/05	SW-846 8270C	Benzo(k)fluoranthene	230 T	µg/kg	IS	<50		J	None	Datum is estimate, bias unknown; all IS area recoveries outside acceptance criteria
TS	TS-211205-1715	12/21/05	SW-846 8270C	Chrysene	520	µg/kg	IS	<50		J	None	Datum is estimate, bias unknown; all IS area recoveries outside acceptance criteria
TS	TS-211205-1715	12/21/05	SW-846 8270C	3/4-Methylphenols (m & p Cresols)	<450	µg/kg	IS	<50		UJ	Low	Possible false negative; all IS area recoveries outside acceptance criteria
TS	TS-211205-1715	12/21/05	SW-846 8270C	Dibenz(a,h)anthracene	86 T	µg/kg	IS	<50		J	None	Datum is estimate, bias unknown; all IS area recoveries outside acceptance criteria
TS	TS-211205-1715	12/21/05	SW-846 8270C	Fluoranthene	820	µg/kg	IS	<50		J	None	Datum is estimate, bias unknown; all IS area recoveries outside acceptance criteria

TABLE 1
DATA QUALIFIERS SUMMARY TABLE
DEMONSTRATION TESTING AND FULL-SCALE OPERATION OF THE BIOGENESIS SEDIMENT DECONTAMINATION PROCESS, KEASBEY, NEW JERSEY
(Page 4 of 188)

Location Identification	Sample Identification	Sample Date	Analysis	Analyte	Sample Result	Sample Units	QC Type	QC Result	QC Units	Qualifier	Bias	Comment
TS	TS-211205-1715	12/21/05	SW-846 8270C	Fluorene	77 T	µg/kg	IS	<50		J	None	Datum is estimate, bias unknown; all IS area recoveries outside acceptance criteria
TS	TS-211205-1715	12/21/05	SW-846 8270C	Hexachlorobenzene	<450	µg/kg	IS	<50		UJ	Low	Possible false negative; all IS area recoveries outside acceptance criteria
TS	TS-211205-1715	12/21/05	SW-846 8270C	Hexachlorobutadiene	<450	µg/kg	IS	<50		UJ	Low	Possible false negative; all IS area recoveries outside acceptance criteria
TS	TS-211205-1715	12/21/05	SW-846 8270C	Hexachloroethane	<450	µg/kg	IS	<50		UJ	Low	Possible false negative; all IS area recoveries outside acceptance criteria
TS	TS-211205-1715	12/21/05	SW-846 8270C	Indeno(1,2,3-c,d)pyrene	380 T	µg/kg	IS	<50		J	None	Datum is estimate, bias unknown; all IS area recoveries outside acceptance criteria
TS	TS-211205-1715	12/21/05	SW-846 8270C	Naphthalene	150 T	µg/kg	IS	<50		J	None	Datum is estimate, bias unknown; all IS area recoveries outside acceptance criteria
TS	TS-211205-1715	12/21/05	SW-846 8270C	Nitrobenzene	<450	µg/kg	IS	<50		UJ	Low	Possible false negative; all IS area recoveries outside acceptance criteria
TS	TS-211205-1715	12/21/05	SW-846 8270C	Pyrene	840	µg/kg	IS	<50		J	None	Datum is estimate, bias unknown; all IS area recoveries outside acceptance criteria
TS	TS-211205-1715	12/21/05	SW-846 8290	1,2,3,4,6,7,8-Heptachlorodibenzo-p-dioxin	2.7 T	pg/g	LB	0.11 T	pg/g	B	None	Analyte detected in associated blank; sample concentration greater than five times the blank concentration
TS	TS-211205-1715	12/21/05	SW-846 8290	1,2,3,4,6,7,8-Heptachlorodibenzofuran	0.67 T	pg/g	LB	0.12 T	pg/g	B	None	Analyte detected in associated blank; sample concentration greater than five times the blank concentration
TS	TS-211205-1715	12/21/05	SW-846 8290	1,2,3,4,7,8-Hexachlorodibenzo-p-dioxin	0.17 T	pg/g	IAR	0.69	N/A	J	None	Datum is estimated, bias unknown; ion abundance ratio outside acceptance criteria
TS	TS-211205-1715	12/21/05	SW-846 8290	1,2,3,4,7,8-Hexachlorodibenzofuran	0.22 T	pg/g	IAR	0.73	N/A	J	None	Datum is estimated, bias unknown; ion abundance ratio outside acceptance criteria
TS	TS-211205-1715	12/21/05	SW-846 8290	1,2,3,6,7,8-Hexachlorodibenzo-p-Dioxin	0.11 T	pg/g	IAR	0.4	N/A	J	None	Datum is estimated, bias unknown; ion abundance ratio outside acceptance criteria
TS	TS-211205-1715	12/21/05	SW-846 8290	1,2,3,7,8,9-Hexachlorodibenzo-p-Dioxin	0.18 T	pg/g	IAR LB	0.63 0.11 T	N/A pg/g	JUB	None	Datum is estimated, bias unknown; ion abundance ratio outside acceptance criteria. Analyte considered not detected, analyte detected in associated blank; sample concentration less than five times the blank concentration
TS	TS-211205-1715	12/21/05	SW-846 8290	1,2,3,7,8,9-Hexachlorodibenzofuran	0.13 T	pg/g	IAR	1.78	N/A	J	None	Datum is estimated, bias unknown; ion abundance ratio outside acceptance criteria
TS	TS-211205-1715	12/21/05	SW-846 8290	1,2,3,7,8-Pentachlorodibenzo-p-dioxin	0.17 T	pg/g	IAR	0.62	N/A	J	None	Datum is estimated, bias unknown; ion abundance ratio outside acceptance criteria

TABLE 1
DATA QUALIFIERS SUMMARY TABLE
DEMONSTRATION TESTING AND FULL-SCALE OPERATION OF THE BIOGENESIS SEDIMENT DECONTAMINATION PROCESS, KEASBEY, NEW JERSEY
(Page5 of 188)

Location Identification	Sample Identification	Sample Date	Analysis	Analyte	Sample Result	Sample Units	QC Type	QC Result	QC Units	Qualifier	Bias	Comment
TS	TS-211205-1715	12/21/05	SW-846 8290	1,2,3,7,8-Pentachlorodibenzofuran	0.089 T	pg/g	IAR LB	0.7 0.063 T	N/A pg/g	JUB	None	Datum is estimated, bias unknown; ion abundance ratio outside acceptance criteria. Analyte considered not detected, analyte detected in associated blank; sample concentration less than five times the blank concentration
TS	TS-211205-1715	12/21/05	SW-846 8290	2,3,4,7,8-Pentachlorodibenzofuran	0.19 T	pg/g	IAR LB	0.68 0.051 T	N/A pg/g	JUB	None	Datum is estimated, bias unknown; ion abundance ratio outside acceptance criteria. Analyte considered not detected, analyte detected in associated blank; sample concentration less than five times the blank concentration
TS	TS-211205-1715	12/21/05	SW-846 8290	Octachlorodibenzo-p-dioxin	52	pg/g	LB	0.47 T	pg/g	B	None	Analyte detected in associated blank; sample concentration greater than five times the blank concentration
TS	TS-211205-1715	12/21/05	SW-846 8290	Octachlorodibenzofuran	0.81 T	pg/g	IAR LB	0.75 0.21 T	N/A pg/g	JUB	None	Datum is estimated, bias unknown; ion abundance ratio outside acceptance criteria. Analyte considered not detected, analyte detected in associated blank; sample concentration less than five times the blank concentration
WS1	WS1-211205-1800	12/21/05	SW-846 6010B	Chromium, total	84.6	mg/kg	LB	0.12 T	mg/kg	B	None	Analyte detected in associated blank; sample concentration greater than five times the blank concentration
WS1	WS1-211205-1800	12/21/05	SW-846 6010B	Zinc	354	mg/kg	LB	0.77 T	mg/kg	B	None	Analyte detected in associated blank; sample concentration greater than five times the blank concentration
WS1	WS1-211205-1800	12/21/05	SW-846 8081A	Alpha-Chlordane	6.6	µg/kg	CONF	69	%	J	None	Datum is estimated, bias unknown; %D between primary and secondary GC columns outside acceptance criterion
WS1	WS1-211205-1800	12/21/05	SW-846 8081A	beta Endosulfan	7.1	µg/kg	CONF	72	%	J	None	Datum is estimated, bias unknown; %D between primary and secondary GC columns outside acceptance criterion
WS1	WS1-211205-1800	12/21/05	SW-846 8081A	Endosulfan sulfate	3.4 T	µg/kg	CONF	228.9	%	J	None	Datum is estimated, bias unknown; %D between primary and secondary GC columns outside acceptance criterion
WS1	WS1-211205-1800	12/21/05	SW-846 8081A	Gamma-Chlordane	2 T	µg/kg	CONF	433.8	%	J	None	Datum is estimated, bias unknown; %D between primary and secondary GC columns outside acceptance criterion
WS1	WS1-211205-1800	12/21/05	SW-846 8081A	Heptachlor epoxide	1.1 T	µg/kg	CONF	334.9	%	J	None	Datum is estimated, bias unknown; %D between primary and secondary GC columns outside acceptance criterion
WS1	WS1-211205-1800	12/21/05	SW-846 8081A	p,p'-DDD	9.7	µg/kg	CONF	71.9	%	J	None	Datum is estimated, bias unknown; %D between primary and secondary GC columns outside acceptance criterion
WS1	WS1-211205-1800	12/21/05	SW-846 8082	2,2',3,4,5'-Pentachlorobiphenyl	2.5 TD	µg/kg	CONF	98.6	%	J	None	Datum is estimated, bias unknown; %D between primary and secondary GC columns outside acceptance criterion
WS1	WS1-211205-1800	12/21/05	SW-846 8082	2,2',5-Trichlorobiphenyl	6.3 D	µg/kg	CONF	44	%	J	None	Datum is estimated, bias unknown; %D between primary and secondary GC columns outside acceptance criterion
WS1	WS1-211205-1800	12/21/05	SW-846 8290	1,2,3,4,6,7,8-Heptachlorodibenzo-p-dioxin	12 T	pg/g	LB	0.11 T	pg/g	B	None	Analyte detected in associated blank; sample concentration greater than five times the blank concentration

TABLE 1
DATA QUALIFIERS SUMMARY TABLE
DEMONSTRATION TESTING AND FULL-SCALE OPERATION OF THE BIOGENESIS SEDIMENT DECONTAMINATION PROCESS, KEASBEY, NEW JERSEY
(Page 6 of 188)

Location Identification	Sample Identification	Sample Date	Analysis	Analyte	Sample Result	Sample Units	QC Type	QC Result	QC Units	Qualifier	Bias	Comment
WS1	WS1-211205-1800	12/21/05	SW-846 8290	1,2,3,4,6,7,8-Heptachlorodibenzofuran	1.8 T	pg/g	LB	0.12 T	pg/g	B	None	Analyte detected in associated blank; sample concentration greater than five times the blank concentration
WS1	WS1-211205-1800	12/21/05	SW-846 8290	1,2,3,4,7,8-Hexachlorodibenzofuran	0.6 T	pg/g	IAR	1.76	N/A	J	None	Datum is estimated, bias unknown; ion abundance ratio outside acceptance criteria
WS1	WS1-211205-1800	12/21/05	SW-846 8290	1,2,3,7,8,9-Hexachlorodibenzo-p-Dioxin	0.39 T	pg/g	IAR LB	1.98 0.11 T	N/A pg/g	JUB	None	Datum is estimated, bias unknown; ion abundance ratio outside acceptance criteria. Analyte considered not detected, analyte detected in associated blank; sample concentration less than five times the blank concentration
WS1	WS1-211205-1800	12/21/05	SW-846 8290	1,2,3,7,8-Pentachlorodibenzofuran	0.39 T	pg/g	IAR LB	1.27 0.063 T	N/A pg/g	JB	None	Datum is estimated, bias unknown; ion abundance ratio outside acceptance criteria. Analyte detected in associated blank; sample concentration greater than five times the blank concentration
WS1	WS1-211205-1800	12/21/05	SW-846 8290	2,3,4,7,8-Pentachlorodibenzofuran	0.3 T	pg/g	IAR LB	0.6 0.051 T	N/A pg/g	JB	None	Datum is estimated, bias unknown; ion abundance ratio outside acceptance criteria. Analyte detected in associated blank; sample concentration greater than five times the blank concentration
WS1	WS1-211205-1800	12/21/05	SW-846 8290	2,3,7,8-Tetrachlorodibenzofuran	0.96 T	pg/g	IAR	0.57	N/A	J	None	Datum is estimated, bias unknown; ion abundance ratio outside acceptance criteria
WS1	WS1-211205-1800	12/21/05	SW-846 8290	Octachlorodibenzo-p-dioxin	610	pg/g	LB	0.47 T	pg/g	B	None	Analyte detected in associated blank; sample concentration greater than five times the blank concentration
WS1	WS1-211205-1800	12/21/05	SW-846 8290	Octachlorodibenzofuran	2.4 T	pg/g	IAR LB	0.69 0.21 T	N/A pg/g	JB	None	Datum is estimated, bias unknown; ion abundance ratio outside acceptance criteria. Analyte detected in associated blank; sample concentration greater than five times the blank concentration
TS	TS-291205-1100	12/29/05	SW-846 8270 SIM	Pyrene	490	µg/kg	CVS	30	%	J	None	Datum is estimated, bias unknown; CVS %D outside acceptance criterion
TS	TS-291205-1100	12/29/05	SW-846 6010B	Chromium, total	26.4	mg/kg	LB	0.098 T	mg/kg	B	None	Analyte detected in associated blank; sample concentration greater than five times the blank concentration
TS	TS-291205-1100	12/29/05	SW-846 6010B	Lead	55	mg/kg	LB	0.18 T	mg/kg	B	None	Analyte detected in associated blank; sample concentration greater than five times the blank concentration
TS	TS-291205-1100	12/29/05	SW-846 6010B	Zinc	131	mg/kg	SLD LB	11.2 0.58 T	% mg/kg	JB	None	Datum is estimated, bias unknown; serial dilution percent difference outside acceptance criterion. Analyte detected in associated blank; sample concentration greater than five times the blank concentration
TS	TS-291205-1100	12/29/05	SW-846 8081A	Aldrin	0.55 T	µg/kg	CONF	689.7	%	J	None	Datum is estimated, bias unknown; %D between primary and secondary GC columns outside acceptance criterion
TS	TS-291205-1100	12/29/05	SW-846 8081A	Alpha BHC (alpha Hexachlorocyclohexane)	0.32 T	µg/kg	CONF	317	%	J	None	Datum is estimated, bias unknown; %D between primary and secondary GC columns outside acceptance criterion

TABLE 1
DATA QUALIFIERS SUMMARY TABLE
DEMONSTRATION TESTING AND FULL-SCALE OPERATION OF THE BIOGENESIS SEDIMENT DECONTAMINATION PROCESS, KEASBEY, NEW JERSEY
(Page 7 of 188)

Location Identification	Sample Identification	Sample Date	Analysis	Analyte	Sample Result	Sample Units	QC Type	QC Result	QC Units	Qualifier	Bias	Comment	
TS	TS-291205-1100	12/29/05	SW-846 8081A		Dieldrin	1.5 T	µg/kg	CONF	110.5	%	J	None	Datum is estimated, bias unknown; %D between primary and secondary GC columns outside acceptance criterion
TS	TS-291205-1100	12/29/05	SW-846 8081A		Gamma-Chlordane	0.73 T	µg/kg	CONF	654.3	%	J	None	Datum is estimated, bias unknown; %D between primary and secondary GC columns outside acceptance criterion
TS	TS-291205-1100	12/29/05	SW-846 8081A		Heptachlor epoxide	0.45 T	µg/kg	CONF	237.1	%	J	None	Datum is estimated, bias unknown; %D between primary and secondary GC columns outside acceptance criterion
TS	TS-291205-1100	12/29/05	SW-846 8081A		p,p'-DDE	2.8	µg/kg	CONF	57	%	J	None	Datum is estimated, bias unknown; %D between primary and secondary GC columns outside acceptance criterion
TS	TS-291205-1100	12/29/05	SW-846 8082		2,2',3,4,5'-Pentachlorobiphenyl	2.4 D	µg/kg	CONF	85.7	%	J	None	Datum is estimated, bias unknown; %D between primary and secondary GC columns outside acceptance criterion
TS	TS-291205-1100	12/29/05	SW-846 8082		2,2',5-Trichlorobiphenyl	5.7 D	µg/kg	CONF	106.8	%	J	None	Datum is estimated, bias unknown; %D between primary and secondary GC columns outside acceptance criterion
TS	TS-291205-1100	12/29/05	SW-846 8082		2,4,5-Trichlorobiphenyl	4.5 D	µg/kg	CONF	114.2	%	J	None	Datum is estimated, bias unknown; %D between primary and secondary GC columns outside acceptance criterion
TS	TS-291205-1100	12/29/05	SW-846 8082		2-Chlorobiphenyl	4.7 TD	µg/kg	CONF	272.5	%	J	None	Datum is estimated, bias unknown; %D between primary and secondary GC columns outside acceptance criterion
TS	TS-291205-1100	12/29/05	SW-846 8290		1,2,3,4,6,7,8-Heptachlorodibenzo-p-dioxin	27	pg/g	LB	0.52 T	pg/g	B	None	Analyte detected in associated blank; sample concentration greater than five times the blank concentration
TS	TS-291205-1100	12/29/05	SW-846 8290		1,2,3,4,6,7,8-Heptachlorodibenzofuran	3.0 T	pg/g	IAR	8.17	N/A	J	None	Datum is estimated, bias unknown; ion abundance ratio outside acceptance criteria
TS	TS-291205-1100	12/29/05	SW-846 8290		1,2,3,4,7,8-Hexachlorodibenzofuran	1.0 T	pg/g	IAR	1.66	N/A	J	None	Datum is estimated, bias unknown; ion abundance ratio outside acceptance criteria
TS	TS-291205-1100	12/29/05	SW-846 8290		1,2,3,7,8-Pentachlorodibenzofuran	0.46 T	pg/g	IAR LB	0.78 0.16 T	N/A pg/g	JUB	None	Datum is estimated, bias unknown; ion abundance ratio outside acceptance criteria. Analyte considered not detected, analyte detected in associated blank; sample concentration less than five times the blank concentration
TS	TS-291205-1100	12/29/05	SW-846 8290		2,3,4,7,8-Pentachlorodibenzofuran	0.63 T	pg/g	IAR LB	1.19 0.22 T	N/A pg/g	JUB	None	Datum is estimated, bias unknown; ion abundance ratio outside acceptance criteria. Analyte considered not detected, analyte detected in associated blank; sample concentration less than five times the blank concentration
TS	TS-291205-1100	12/29/05	SW-846 8290		2,3,7,8-Tetrachlorodibenzofuran	1.3 T	pg/g	IAR	1.13	N/A	J	None	Datum is estimated, bias unknown; ion abundance ratio outside acceptance criteria
TS	TS-291205-1100	12/29/05	SW-846 8290		Octachlorodibenzo-p-dioxin	1600	pg/g	LB	4.0 T	pg/g	B	None	Analyte detected in associated blank; sample concentration greater than five times the blank concentration
TS	TS-291205-1100	12/29/05	SW-846 8290		Octachlorodibenzofuran	4.6 T	pg/g	LB	1.0 T	pg/g	UB	None	Analyte considered not detected, analyte detected in associated blank; sample concentration less than five times the blank concentration

TABLE 1
DATA QUALIFIERS SUMMARY TABLE
DEMONSTRATION TESTING AND FULL-SCALE OPERATION OF THE BIOGENESIS SEDIMENT DECONTAMINATION PROCESS, KEASBEY, NEW JERSEY
(Page 8 of 188)

Location Identification	Sample Identification	Sample Date	Analysis	Analyte	Sample Result	Sample Units	QC Type	QC Result	QC Units	Qualifier	Bias	Comment
WS	WS-291205-1110	12/29/05	SW-846 8270 SIM	Pyrene	66	µg/kg	CVS	30	%	J	None	Datum is estimated, bias unknown; CVS %D outside acceptance criterion
WS	WS-291205-1110	12/29/05	SW-846 6010B	Chromium, total	83.3	mg/kg	LB	0.098 T	mg/kg	B	None	Analyte detected in associated blank; sample concentration greater than five times the blank concentration
WS	WS-291205-1110	12/29/05	SW-846 6010B	Lead	178	mg/kg	LB	0.18 T	mg/kg	B	None	Analyte detected in associated blank; sample concentration greater than five times the blank concentration
WS	WS-291205-1110	12/29/05	SW-846 6010B	Zinc	321	mg/kg	LB	0.58 T	mg/kg	B	None	Analyte detected in associated blank; sample concentration greater than five times the blank concentration
WS	WS-291205-1110	12/29/05	SW-846 8081A	Aldrin	1.6 T	µg/kg	CONF	656.3	%	J	None	Datum is estimated, bias unknown; %D between primary and secondary GC columns outside acceptance criterion
WS	WS-291205-1110	12/29/05	SW-846 8081A	Alpha BHC (alpha Hexachlorocyclohexane)	0.99 T	µg/kg	CONF	188.6	%	J	None	Datum is estimated, bias unknown; %D between primary and secondary GC columns outside acceptance criterion
WS	WS-291205-1110	12/29/05	SW-846 8081A	beta Endosulfan	5.4	µg/kg	CONF	70.1	%	J	None	Datum is estimated, bias unknown; %D between primary and secondary GC columns outside acceptance criterion
WS	WS-291205-1110	12/29/05	SW-846 8081A	Gamma-Chlordane	2.5 T	µg/kg	CONF	474.4	%	J	None	Datum is estimated, bias unknown; %D between primary and secondary GC columns outside acceptance criterion
WS	WS-291205-1110	12/29/05	SW-846 8081A	Heptachlor epoxide	1.8 T	µg/kg	CONF	130.3	%	J	None	Datum is estimated, bias unknown; %D between primary and secondary GC columns outside acceptance criterion
WS	WS-291205-1110	12/29/05	SW-846 8081A	p,p'-DDE	8.8	µg/kg	CONF	41.3	%	J	None	Datum is estimated, bias unknown; %D between primary and secondary GC columns outside acceptance criterion
WS	WS-291205-1110	12/29/05	SW-846 8082	2,2',3,3',4,4',5-Heptachlorobiphenyl	0.76 TD	µg/kg	CONF	96.3	%	J	None	Datum is estimated, bias unknown; %D between primary and secondary GC columns outside acceptance criterion
WS	WS-291205-1110	12/29/05	SW-846 8082	2,2',3,4,5'-Pentachlorobiphenyl	3.5 D	µg/kg	CONF	90.2	%	J	None	Datum is estimated, bias unknown; %D between primary and secondary GC columns outside acceptance criterion
WS	WS-291205-1110	12/29/05	SW-846 8082	2,2',5-Trichlorobiphenyl	8.3 D	µg/kg	CONF	44.9	%	J	None	Datum is estimated, bias unknown; %D between primary and secondary GC columns outside acceptance criterion
WS	WS-291205-1110	12/29/05	SW-846 8290	1,2,3,4,6,7,8-Heptachlorodibenzo-p-dioxin	5.6 T	pg/g	LB	0.52 T	pg/g	B	None	Analyte detected in associated blank; sample concentration greater than five times the blank concentration
WS	WS-291205-1110	12/29/05	SW-846 8290	1,2,3,4,6,7,8-Heptachlorodibenzofuran	1.1 T	pg/g	IAR	0.87	N/A	J	None	Datum is estimated, bias unknown; ion abundance ratio outside acceptance criteria
WS	WS-291205-1110	12/29/05	SW-846 8290	1,2,3,6,7,8-Hexachlorodibenzo-p-Dioxin	0.49 T	pg/g	IAR	1.03	N/A	J	None	Datum is estimated, bias unknown; ion abundance ratio outside acceptance criteria

TABLE 1
DATA QUALIFIERS SUMMARY TABLE
DEMONSTRATION TESTING AND FULL-SCALE OPERATION OF THE BIOGENESIS SEDIMENT DECONTAMINATION PROCESS, KEASBEY, NEW JERSEY
(Page9 of 188)

Location Identification	Sample Identification	Sample Date	Analysis	Analyte	Sample Result	Sample Units	QC Type	QC Result	QC Units	Qualifier	Bias	Comment
WS	WS-291205-1110	12/29/05	SW-846 8290	1,2,3,7,8,9-Hexachlorodibenzo-p-Dioxin	0.39 T	pg/g	IAR	0.88	N/A	J	None	Datum is estimated, bias unknown; ion abundance ratio outside acceptance criteria
WS	WS-291205-1110	12/29/05	SW-846 8290	1,2,3,7,8-Pentachlorodibenzofuran	0.086 T	pg/g	IAR LB	0.48 0.16 T	N/A pg/g	JUB	None	Datum is estimated, bias unknown; ion abundance ratio outside acceptance criteria. Analyte considered not detected, analyte detected in associated blank; sample concentration less than five times the blank concentration
WS	WS-291205-1110	12/29/05	SW-846 8290	2,3,4,7,8-Pentachlorodibenzofuran	0.35 T	pg/g	IAR LB	1.02 0.22 T	N/A pg/g	JUB	None	Datum is estimated, bias unknown; ion abundance ratio outside acceptance criteria. Analyte considered not detected, analyte detected in associated blank; sample concentration less than five times the blank concentration
WS	WS-291205-1110	12/29/05	SW-846 8290	2,3,7,8-Tetrachlorodibenzofuran	1.3 T	pg/g	IAR	0.59	N/A	J	None	Datum is estimated, bias unknown; ion abundance ratio outside acceptance criteria
WS	WS-291205-1110	12/29/05	SW-846 8290	Octachlorodibenzo-p-dioxin	170	pg/g	LB	4.0 T	pg/g	B	None	Analyte detected in associated blank; sample concentration greater than five times the blank concentration
WS	WS-291205-1110	12/29/05	SW-846 8290	Octachlorodibenzofuran	2.0 T	pg/g	LB	1.0 T	pg/g	UB	None	Analyte considered not detected, analyte detected in associated blank; sample concentration less than five times the blank concentration
RS	RS-030106-1600	01/03/06	SW-846 8270 SIM	Pyrene	380	µg/kg	CVS	30	%	J	None	Datum is estimated, bias unknown; CVS %D outside acceptance criterion
RS	RS-030106-1600	01/03/06	SW-846 6010B	Zinc	151	mg/kg	MS SLD LB	130 10.2 0.37 T	% % mg/kg	JB	High	Datum is estimated, possible high bias; MS recovery and serial dilution %D outside acceptance criteria. Analyte detected in associated blank; sample concentration greater than five times the blank concentration
RS	RS-030106-1600	01/03/06	SW-846 8081A	Dieldrin	2.0 T	µg/kg	CONF	80.6	%	J	None	Datum is estimated, bias unknown; %D between primary and secondary GC columns outside acceptance criterion
RS	RS-030106-1600	01/03/06	SW-846 8081A	Endosulfan sulfate	2.3 T	µg/kg	CONF	194.6	%	J	None	Datum is estimated, bias unknown; %D between primary and secondary GC columns outside acceptance criterion
RS	RS-030106-1600	01/03/06	SW-846 8081A	Gamma-Chlordane	0.77 T	µg/kg	CONF	470.9	%	J	None	Datum is estimated, bias unknown; %D between primary and secondary GC columns outside acceptance criterion
RS	RS-030106-1600	01/03/06	SW-846 8081A	p,p'-DDD	2.0 T	µg/kg	CONF	282.5	%	J	None	Datum is estimated, bias unknown; %D between primary and secondary GC columns outside acceptance criterion
RS	RS-030106-1600	01/03/06	SW-846 8081A	p,p'-DDT	2.7 T	µg/kg	CONF	323.2	%	J	None	Datum is estimated, bias unknown; %D between primary and secondary GC columns outside acceptance criterion
RS	RS-030106-1600	01/03/06	SW-846 8082	2,2',3,3',4,4',5,5',6-Nonachlorobiphenyl	0.29 TD	µg/kg	CONF	476.8	%	J	None	Datum is estimated, bias unknown; %D between primary and secondary GC columns outside acceptance criterion
RS	RS-030106-1600	01/03/06	SW-846 8082	2,2',3,3',4,4',5-Heptachlorobiphenyl	0.67 TD	µg/kg	CONF	47.5	%	J	None	Datum is estimated, bias unknown; %D between primary and secondary GC columns outside acceptance criterion
RS	RS-030106-1600	01/03/06	SW-846 8082	2,2',3,4,4',5,5'-Heptachlorobiphenyl	0.87 TD	µg/kg	CONF	83.8	%	J	None	Datum is estimated, bias unknown; %D between primary and secondary GC columns outside acceptance criterion

TABLE 1
DATA QUALIFIERS SUMMARY TABLE
DEMONSTRATION TESTING AND FULL-SCALE OPERATION OF THE BIOGENESIS SEDIMENT DECONTAMINATION PROCESS, KEASBEY, NEW JERSEY
 (Page10 of 188)

Location Identification	Sample Identification	Sample Date	Analysis	Analyte	Sample Result	Sample Units	QC Type	QC Result	QC Units	Qualifier	Bias	Comment
RS	RS-030106-1600	01/03/06	SW-846 8082	2,2',3,4,5'-Pentachlorobiphenyl	2 4 D	µg/kg	CONF	70 6	%	J	None	Datum is estimated, bias unknown; %D between primary and secondary GC columns outside acceptance criterion
RS	RS-030106-1600	01/03/06	SW-846 8082	2,2',3,4,5,5'-Hexachlorobiphenyl	0 63 TD	µg/kg	CONF	246 2	%	J	None	Datum is estimated, bias unknown; %D between primary and secondary GC columns outside acceptance criterion
RS	RS-030106-1600	01/03/06	SW-846 8082	2,2',4,5,5'-Pentachlorobiphenyl	4 7 D	µg/kg	MS MSD	9 1 8 6	%	J	Low	Datum is estimated, possible low bias; MS/MSD recoveries outside acceptance criteria
RS	RS-030106-1600	01/03/06	SW-846 8082	2,2',5-Trichlorobiphenyl	4 6 D	µg/kg	CONF	183 8	%	J	None	Datum is estimated, bias unknown; %D between primary and secondary GC columns outside acceptance criterion
RS	RS-030106-1600	01/03/06	SW-846 8082	2,3-Dichlorobiphenyl	1 7 D	µg/kg	CONF	122 3	%	J	None	Datum is estimated, bias unknown; %D between primary and secondary GC columns outside acceptance criterion
RS	RS-030106-1600	01/03/06	SW-846 8082	2,4,5-Trichlorobiphenyl	4 9 D	µg/kg	CONF	148 9	%	J	None	Datum is estimated, bias unknown; %D between primary and secondary GC columns outside acceptance criterion
RS	RS-030106-1600	01/03/06	SW-846 8082	2-Chlorobiphenyl	3 9 TD	µg/kg	CONF	999 9	%	J	None	Datum is estimated, bias unknown; %D between primary and secondary GC columns outside acceptance criterion
RS	RS-030106-1600	01/03/06	SW-846 8270C	1,4-Dichlorobenzene	<1800 D	µg/kg	MS	34	%	UJ	Low	Possible false negative; MS recovery outside acceptance criteria
RS	RS-030106-1600	01/03/06	SW-846 8270C	Hexachloroethane	<1800 D	µg/kg	MS	33	%	UJ	Low	Possible false negative; MS recovery outside acceptance criteria
RS	RS-030106-1600	01/03/06	SW-846 8290	1,2,3,4,6,7,8-Heptachlorodibenzo-p-dioxin	170	pg/g	LB	0 36 T	pg/g	B	None	Analyte detected in associated blank; sample concentration greater than five times the blank concentration
RS	RS-030106-1600	01/03/06	SW-846 8290	1,2,3,4,6,7,8-Heptachlorodibenzofuran	23	pg/g	LB	0 29 T	pg/g	B	None	Analyte detected in associated blank; sample concentration greater than five times the blank concentration
RS	RS-030106-1600	01/03/06	SW-846 8290	1,2,3,4,7,8,9-Heptachlorodibenzofuran	2 4 T	pg/g	IAR	1 52	N/A	J	None	Datum is estimated, bias unknown; ion abundance ratio outside acceptance criteria
RS	RS-030106-1600	01/03/06	SW-846 8290	1,2,3,4,7,8-Hexachlorodibenzo-p-dioxin	2 4 T	pg/g	IAR	1 03	N/A	J	None	Datum is estimated, bias unknown; ion abundance ratio outside acceptance criteria
RS	RS-030106-1600	01/03/06	SW-846 8290	1,2,3,7,8,9-Hexachlorodibenzo-p-Dioxin	7 6 T	pg/g	LB	0 16 T	pg/g	B	None	Analyte detected in associated blank; sample concentration greater than five times the blank concentration
RS	RS-030106-1600	01/03/06	SW-846 8290	1,2,3,7,8,9-Hexachlorodibenzofuran	30	pg/g	IAR LB	1 82 0 22 T	N/A pg/g	JB	None	Datum is estimated, bias unknown; ion abundance ratio outside acceptance criteria Analyte detected in associated blank; sample concentration greater than five times the blank concentration
RS	RS-030106-1600	01/03/06	SW-846 8290	1,2,3,7,8-Pentachlorodibenzofuran	2 4 T	pg/g	LB	0 11 T	pg/g	B	None	Analyte detected in associated blank; sample concentration greater than five times the blank concentration

TABLE 1
DATA QUALIFIERS SUMMARY TABLE
DEMONSTRATION TESTING AND FULL-SCALE OPERATION OF THE BIOGENESIS SEDIMENT DECONTAMINATION PROCESS, KEASBEY, NEW JERSEY
(Page11 of 188)

Location Identification	Sample Identification	Sample Date	Analysis	Analyte	Sample Result	Sample Units	QC Type	QC Result	QC Units	Qualifier	Bias	Comment
RS	RS-030106-1600	01/03/06	SW-846 8290	2,3,4,6,7,8-Hexachlorodibenzofuran	2.3	T pg/g	IAR LB	1.51 0.15	N/A T pg/g	JB	None	Datum is estimated, bias unknown; ion abundance ratio outside acceptance criteria. Analyte detected in associated blank; sample concentration greater than five times the blank concentration.
RS	RS-030106-1600	01/03/06	SW-846 8290	2,3,4,7,8-Pentachlorodibenzofuran	3.6	T pg/g	LB	0.11	T pg/g	B	None	Analyte detected in associated blank; sample concentration greater than five times the blank concentration.
RS	RS-030106-1600	01/03/06	SW-846 8290	2,3,7,8-Tetrachlorodibenzo-p-dioxin	1.5	T pg/g	IAR	0.59	N/A	J	None	Datum is estimated, bias unknown; ion abundance ratio outside acceptance criteria.
RS	RS-030106-1600	01/03/06	SW-846 8290	Octachlorodibenzo-p-dioxin	9400	pg/g	LB	1.8	T pg/g	B	None	Analyte detected in associated blank; sample concentration greater than five times the blank concentration.
RS	RS-030106-1600	01/03/06	SW-846 8290	Octachlorodibenzofuran	21	T pg/g	LB	0.37	T pg/g	B	None	Analyte detected in associated blank; sample concentration greater than five times the blank concentration.
TS	TS-030106-1645	01/03/06	SW-846 8270 SIM	Pyrene	570	µg/kg	CVS	30	%	J	None	Datum is estimated, bias unknown; CVS %D outside acceptance criterion.
TS	TS-030106-1645	01/03/06	SW-846 6010B	Zinc	104	mg/kg	LB	0.37	T mg/kg	B	None	Analyte detected in associated blank; sample concentration greater than five times the blank concentration.
TS	TS-030106-1645	01/03/06	SW-846 8081A	beta Endosulfan	1.0	T µg/kg	CONF	414.7	%	J	None	Datum is estimated, bias unknown; %D between primary and secondary GC columns outside acceptance criterion.
TS	TS-030106-1645	01/03/06	SW-846 8081A	Dieldrin	2.7	µg/kg	CONF	65.9	%	J	None	Datum is estimated, bias unknown; %D between primary and secondary GC columns outside acceptance criterion.
TS	TS-030106-1645	01/03/06	SW-846 8081A	Gamma-Chlordane	0.63	T µg/kg	CONF	790.4	%	J	None	Datum is estimated, bias unknown; %D between primary and secondary GC columns outside acceptance criterion.
TS	TS-030106-1645	01/03/06	SW-846 8081A	Heptachlor epoxide	0.79	T µg/kg	CONF	246.7	%	J	None	Datum is estimated, bias unknown; %D between primary and secondary GC columns outside acceptance criterion.
TS	TS-030106-1645	01/03/06	SW-846 8081A	Methoxychlor	2.6	T µg/kg	CONF	184.7	%	J	None	Datum is estimated, bias unknown; %D between primary and secondary GC columns outside acceptance criterion.
TS	TS-030106-1645	01/03/06	SW-846 8081A	p,p'-DDD	4	µg/kg	CONF	82.8	%	J	None	Datum is estimated, bias unknown; %D between primary and secondary GC columns outside acceptance criterion.
TS	TS-030106-1645	01/03/06	SW-846 8081A	p,p'-DDT	5.6	µg/kg	CONF	66.5	%	J	None	Datum is estimated, bias unknown; %D between primary and secondary GC columns outside acceptance criterion.
TS	TS-030106-1645	01/03/06	SW-846 8082	2,2',3,4,4',5,5'-Heptachlorobiphenyl	1.1	TD µg/kg	CONF	56.4	%	J	None	Datum is estimated, bias unknown; %D between primary and secondary GC columns outside acceptance criterion.
TS	TS-030106-1645	01/03/06	SW-846 8082	2,2',3,4,5'-Pentachlorobiphenyl	2	TD µg/kg	CONF	106.6	%	J	None	Datum is estimated, bias unknown; %D between primary and secondary GC columns outside acceptance criterion.

TABLE 1
DATA QUALIFIERS SUMMARY TABLE
DEMONSTRATION TESTING AND FULL-SCALE OPERATION OF THE BIOGENESIS SEDIMENT DECONTAMINATION PROCESS, KEASBEY, NEW JERSEY
(Page12 of 188)

Location Identification	Sample Identification	Sample Date	Analysis	Analyte	Sample Result	Sample Units	QC Type	QC Result	QC Units	Qualifier	Bias	Comment
TS	TS-030106-1645	01/03/06	SW-846 8082	2,2',3,4,5,5'-Hexachlorobiphenyl	0 88 TD	µg/kg	CONF	128 9	%	J	None	Datum is estimated, bias unknown; %D between primary and secondary GC columns outside acceptance criterion
TS	TS-030106-1645	01/03/06	SW-846 8082	2,2',4,5,5'-Pentachlorobiphenyl	3 6 D	µg/kg	CONF	42	%	J	None	Datum is estimated, bias unknown; %D between primary and secondary GC columns outside acceptance criterion
TS	TS-030106-1645	01/03/06	SW-846 8082	2,2',5-Trichlorobiphenyl	5 1 D	µg/kg	CONF	479 2	%	J	None	Datum is estimated, bias unknown; %D between primary and secondary GC columns outside acceptance criterion
TS	TS-030106-1645	01/03/06	SW-846 8082	2,3-Dichlorobiphenyl	3 4 D	µg/kg	CONF	103 9	%	J	None	Datum is estimated, bias unknown; %D between primary and secondary GC columns outside acceptance criterion
TS	TS-030106-1645	01/03/06	SW-846 8082	2,4,5-Trichlorobiphenyl	5 5 D	µg/kg	CONF	114 3	%	J	None	Datum is estimated, bias unknown; %D between primary and secondary GC columns outside acceptance criterion
TS	TS-030106-1645	01/03/06	SW-846 8082	2-Chlorobiphenyl	15 TD	µg/kg	CONF	46 8	%	J	None	Datum is estimated, bias unknown; %D between primary and secondary GC columns outside acceptance criterion
TS	TS-030106-1645	01/03/06	SW-846 8290	1,2,3,4,6,7,8-Heptachlorodibenzofuran	4 6 T	pg/g	LB	0 16 T	pg/g	B	None	Analyte detected in associated blank; sample concentration greater than five times the blank concentration
TS	TS-030106-1645	01/03/06	SW-846 8290	1,2,3,6,7,8-Hexachlorodibenzofuran	0 59 T	pg/g	IAR	1 67	N/A	J	None	Datum is estimated, bias unknown; ion abundance ratio outside acceptance criteria
TS	TS-030106-1645	01/03/06	SW-846 8290	1,2,3,7,8-Pentachlorodibenzofuran	0 50 T	pg/g	IAR	1 9	N/A	J	None	Datum is estimated, bias unknown; ion abundance ratio outside acceptance criteria
TS	TS-030106-1645	01/03/06	SW-846 8290	2,3,7,8-Tetrachlorodibenzofuran	1 4	pg/g	IAR	0 63	N/A	J	None	Datum is estimated, bias unknown; ion abundance ratio outside acceptance criteria
TS	TS-030106-1645	01/03/06	SW-846 8290	Octachlorodibenzo-p-dioxin	920	pg/g	LB	0 87 T	pg/g	B	None	Analyte detected in associated blank; sample concentration greater than five times the blank concentration
TS	TS-030106-1645	01/03/06	SW-846 8290	Octachlorodibenzofuran	3 9 T	pg/g	LB	0 27 T	pg/g	B	None	Analyte detected in associated blank; sample concentration greater than five times the blank concentration
WS1	WS1-030106-1615	01/03/06	SW-846 8270 SIM	Pyrene	280	µg/kg	CVS	30	%	J	None	Datum is estimated, bias unknown; CVS %D outside acceptance criterion
WS1	WS1-030106-1615	01/03/06	SW-846 6010B	Zinc	328	mg/kg	LB	0 37 T	mg/kg	B	None	Analyte detected in associated blank; sample concentration greater than five times the blank concentration
WS1	WS1-030106-1615	01/03/06	SW-846 8081A	p,p'-DDD	3 4 TD	µg/kg	CONF	57 9	%	J	None	Datum is estimated, bias unknown; %D between primary and secondary GC columns outside acceptance criterion
WS1	WS1-030106-1615	01/03/06	SW-846 8082	2,2',3,3',4,4',5,5',6-Nonachlorobiphenyl	0 47 TD	µg/kg	CONF	48 6	%	J	None	Datum is estimated, bias unknown; %D between primary and secondary GC columns outside acceptance criterion

TABLE 1
DATA QUALIFIERS SUMMARY TABLE
DEMONSTRATION TESTING AND FULL-SCALE OPERATION OF THE BIOGENESIS SEDIMENT DECONTAMINATION PROCESS, KEASBEY, NEW JERSEY
(Page13 of 188)

Location Identification	Sample Identification	Sample Date	Analysis	Analyte	Sample Result	Sample Units	QC Type	QC Result	QC Units	Qualifier	Bias	Comment
WS1	WS1-030106-1615	01/03/06	SW-846 8082	2,2',3,3',4,4',5-Heptachlorobiphenyl	0 76 TD	µg/kg	CONF	46 9	%	J	None	Datum is estimated, bias unknown; %D between primary and secondary GC columns outside acceptance criterion
WS1	WS1-030106-1615	01/03/06	SW-846 8082	2,2',3,4,5'-Pentachlorobiphenyl	3 D	µg/kg	CONF	127 6	%	J	None	Datum is estimated, bias unknown; %D between primary and secondary GC columns outside acceptance criterion
WS1	WS1-030106-1615	01/03/06	SW-846 8082	2,2',3,4,5,5'-Hexachlorobiphenyl	0 75 TD	µg/kg	CONF	298 5	%	J	None	Datum is estimated, bias unknown; %D between primary and secondary GC columns outside acceptance criterion
WS1	WS1-030106-1615	01/03/06	SW-846 8082	2,2',4,5,5'-Pentachlorobiphenyl	4 6 D	µg/kg	CONF	51 4	%	J	None	Datum is estimated, bias unknown; %D between primary and secondary GC columns outside acceptance criterion
WS1	WS1-030106-1615	01/03/06	SW-846 8082	2,2',5-Trichlorobiphenyl	8 7 D	µg/kg	CONF	46 2	%	J	None	Datum is estimated, bias unknown; %D between primary and secondary GC columns outside acceptance criterion
WS1	WS1-030106-1615	01/03/06	SW-846 8082	2,4,5-Trichlorobiphenyl	7 9 D	µg/kg	CONF	169 4	%	J	None	Datum is estimated, bias unknown; %D between primary and secondary GC columns outside acceptance criterion
WS1	WS1-030106-1615	01/03/06	SW-846 8082	2-Chlorobiphenyl	5 5 TD	µg/kg	CONF	999 9	%	J	None	Datum is estimated, bias unknown; %D between primary and secondary GC columns outside acceptance criterion
WS1	WS1-030106-1615	01/03/06	SW-846 8290	1,2,3,4,6,7,8-Heptachlorodibenzofuran	3 9 T	pg/g	LB	0 16 T	pg/g	B	None	Analyte detected in associated blank; sample concentration greater than five times the blank concentration
WS1	WS1-030106-1615	01/03/06	SW-846 8290	1,2,3,4,7,8-Hexachlorodibenzofuran	0 88 T	pg/g	IAR	0 87	N/A	J	None	Datum is estimated, bias unknown; ion abundance ratio outside acceptance criteria
WS1	WS1-030106-1615	01/03/06	SW-846 8290	1,2,3,6,7,8-Hexachlorodibenzo-p-Dioxin	1 1 T	pg/g	IAR	0 97	N/A	J	None	Datum is estimated, bias unknown; ion abundance ratio outside acceptance criteria
WS1	WS1-030106-1615	01/03/06	SW-846 8290	1,2,3,6,7,8-Hexachlorodibenzofuran	0 35 T	pg/g	IAR	1 46	N/A	J	None	Datum is estimated, bias unknown; ion abundance ratio outside acceptance criteria
WS1	WS1-030106-1615	01/03/06	SW-846 8290	1,2,3,7,8,9-Hexachlorodibenzo-p-Dioxin	1 0 T	pg/g	IAR	1	N/A	J	None	Datum is estimated, bias unknown; ion abundance ratio outside acceptance criteria
WS1	WS1-030106-1615	01/03/06	SW-846 8290	2,3,4,7,8-Pentachlorodibenzofuran	0 67 T	pg/g	IAR	0 97	N/A	J	None	Datum is estimated, bias unknown; ion abundance ratio outside acceptance criteria
WS1	WS1-030106-1615	01/03/06	SW-846 8290	Octachlorodibenzo-p-dioxin	1600	pg/g	LB	0 87 T	pg/g	B	None	Analyte detected in associated blank; sample concentration greater than five times the blank concentration
WS1	WS1-030106-1615	01/03/06	SW-846 8290	Octachlorodibenzofuran	5 3 T	pg/g	LB	0 27 T	pg/g	B	None	Analyte detected in associated blank; sample concentration greater than five times the blank concentration
WS1	WS1-030106-1615	01/03/06	SW-846 8082	2,2',3,4,4',5,5'-Heptachlorobiphenyl	0 76 TD	µg/kg	CONF	61 6	%	J	None	Datum is estimated, bias unknown; %D between primary and secondary GC columns outside acceptance criterion

TABLE 1
DATA QUALIFIERS SUMMARY TABLE
DEMONSTRATION TESTING AND FULL-SCALE OPERATION OF THE BIOGENESIS SEDIMENT DECONTAMINATION PROCESS, KEASBEY, NEW JERSEY
(Page14 of 188)

Location Identification	Sample Identification	Sample Date	Analysis	Analyte	Sample Result	Sample Units	QC Type	QC Result	QC Units	Qualifier	Bias	Comment
WS2	WS2-030106-1630	01/03/06	SW-846 8270 SIM	Pyrene	170	µg/kg	CVS	30	%	J	None	Datum is estimated, bias unknown; CVS %D outside acceptance criterion
WS2	WS2-030106-1630	01/03/06	SW-846 6010B	Zinc	312	mg/kg	LB	0 37 T	mg/kg	B	None	Analyte detected in associated blank; sample concentration greater than five times the blank concentration
WS2	WS2-030106-1630	01/03/06	SW-846 8081A	p,p'-DDE	7 9 TD	µg/kg	CONF	76	%	J	None	Datum is estimated, bias unknown; %D between primary and secondary GC columns outside acceptance criterion
WS2	WS2-030106-1630	01/03/06	SW-846 8081A	p,p'-DDT	2 6 TD	µg/kg	CONF	557 8	%	J	None	Datum is estimated, bias unknown; %D between primary and secondary GC columns outside acceptance criterion
WS2	WS2-030106-1630	01/03/06	SW-846 8082	2,2',3,3',4,4',5-Heptachlorobiphenyl	0 53	µg/kg	CONF	58 3	%	J	None	Datum is estimated, bias unknown; %D between primary and secondary GC columns outside acceptance criterion
WS2	WS2-030106-1630	01/03/06	SW-846 8082	2,2',3,4,5'-Pentachlorobiphenyl	1 4	µg/kg	CONF	149 3	%	J	None	Datum is estimated, bias unknown; %D between primary and secondary GC columns outside acceptance criterion
WS2	WS2-030106-1630	01/03/06	SW-846 8082	2,2',3,4,5,5'-Hexachlorobiphenyl	0 35 T	µg/kg	CONF	333	%	J	None	Datum is estimated, bias unknown; %D between primary and secondary GC columns outside acceptance criterion
WS2	WS2-030106-1630	01/03/06	SW-846 8082	2,2',4,5,5'-Pentachlorobiphenyl	2 1	µg/kg	CONF	58 4	%	J	None	Datum is estimated, bias unknown; %D between primary and secondary GC columns outside acceptance criterion
WS2	WS2-030106-1630	01/03/06	SW-846 8082	2,3-Dichlorobiphenyl	0 67	µg/kg	CONF	240	%	J	None	Datum is estimated, bias unknown; %D between primary and secondary GC columns outside acceptance criterion
WS2	WS2-030106-1630	01/03/06	SW-846 8082	2,4,5-Trichlorobiphenyl	4	µg/kg	CONF	1000	%	J	None	Datum is estimated, bias unknown; %D between primary and secondary GC columns outside acceptance criterion
WS2	WS2-030106-1630	01/03/06	SW-846 8082	2-Chlorobiphenyl	3 4 T	µg/kg	CONF	1000	%	J	None	Datum is estimated, bias unknown; %D between primary and secondary GC columns outside acceptance criterion
WS2	WS2-030106-1630	01/03/06	SW-846 8290	1,2,3,4,6,7,8-Heptachlorodibenzofuran	2 5 T	pg/g	IAR LB	3 1 0 16 T	N/A pg/g	JB	None	Datum is estimated, bias unknown; ion abundance ratio outside acceptance criteria Analyte detected in associated blank; sample concentration greater than five times the blank concentration
WS2	WS2-030106-1630	01/03/06	SW-846 8290	1,2,3,4,7,8-Hexachlorodibenzofuran	0 62 T	pg/g	IAR	0 94	N/A	J	None	Datum is estimated, bias unknown; ion abundance ratio outside acceptance criteria
WS2	WS2-030106-1630	01/03/06	SW-846 8290	1,2,3,7,8-Pentachlorodibenzo-p-dioxin	0 40 T	pg/g	IAR	1 06	N/A	J	None	Datum is estimated, bias unknown; ion abundance ratio outside acceptance criteria
WS2	WS2-030106-1630	01/03/06	SW-846 8290	Octachlorodibenzo-p-dioxin	370	pg/g	LB	0 87 T	pg/g	B	None	Analyte detected in associated blank; sample concentration greater than five times the blank concentration
WS2	WS2-030106-1630	01/03/06	SW-846 8290	Octachlorodibenzofuran	3 4 T	pg/g	LB	0 27 T	pg/g	B	None	Analyte detected in associated blank; sample concentration greater than five times the blank concentration

TABLE 1
DATA QUALIFIERS SUMMARY TABLE
DEMONSTRATION TESTING AND FULL-SCALE OPERATION OF THE BIOGENESIS SEDIMENT DECONTAMINATION PROCESS, KEASBEY, NEW JERSEY
(Page15 of 188)

Location Identification	Sample Identification	Sample Date	Analysis	Analyte	Sample Result	Sample Units	QC Type	QC Result	QC Units	Qualifier	Bias	Comment
RS	RS-040106-1300	01/04/06	SW-846 8270 SIM	Pyrene	390	µg/kg	CVS	30	%	J	None	Datum is estimated, bias unknown; CVS %D outside acceptance criterion
RS	RS-040106-1300	01/04/06	SW-846 6010B	Zinc	249	mg/kg	LB	0 37 T	mg/kg	B	None	Analyte detected in associated blank; sample concentration greater than five times the blank concentration
RS	RS-040106-1300	01/04/06	SW-846 8081A	p,p'-DDD	4 3 TD	µg/kg	CONF	125 9	%	J	None	Datum is estimated, bias unknown; %D between primary and secondary GC columns outside acceptance criterion
RS	RS-040106-1300	01/04/06	SW-846 8081A	p,p'-DDE	6 4 TD	µg/kg	CONF	103 6	%	J	None	Datum is estimated, bias unknown; %D between primary and secondary GC columns outside acceptance criterion
RS	RS-040106-1300	01/04/06	SW-846 8082	2,2',3,4,4',5,5'-Heptachlorobiphenyl	0 64 T	µg/kg	CONF	70	%	J	None	Datum is estimated, bias unknown; %D between primary and secondary GC columns outside acceptance criterion
RS	RS-040106-1300	01/04/06	SW-846 8082	2,2',3,4,5'-Pentachlorobiphenyl	2	µg/kg	CONF	74 7	%	J	None	Datum is estimated, bias unknown; %D between primary and secondary GC columns outside acceptance criterion
RS	RS-040106-1300	01/04/06	SW-846 8082	2,2',3,4,5'-Hexachlorobiphenyl	0 4 T	µg/kg	CONF	324 4	%	J	None	Datum is estimated, bias unknown; %D between primary and secondary GC columns outside acceptance criterion
RS	RS-040106-1300	01/04/06	SW-846 8082	2,2',5-Trichlorobiphenyl	4 7	µg/kg	CONF	85 4	%	J	None	Datum is estimated, bias unknown; %D between primary and secondary GC columns outside acceptance criterion
RS	RS-040106-1300	01/04/06	SW-846 8082	2,3-Dichlorobiphenyl	1 4	µg/kg	CONF	110 8	%	J	None	Datum is estimated, bias unknown; %D between primary and secondary GC columns outside acceptance criterion
RS	RS-040106-1300	01/04/06	SW-846 8082	2,4,5-Trichlorobiphenyl	5 3	µg/kg	CONF	805 4	%	J	None	Datum is estimated, bias unknown; %D between primary and secondary GC columns outside acceptance criterion
RS	RS-040106-1300	01/04/06	SW-846 8082	2-Chlorobiphenyl	4 1 T	µg/kg	CONF	1000	%	J	None	Datum is estimated, bias unknown; %D between primary and secondary GC columns outside acceptance criterion
RS	RS-040106-1300	01/04/06	SW-846 8290	1,2,3,4,6,7,8-Heptachlorodibenzo-p-dioxin	170	pg/g	LB	0 36 T	pg/g	B	None	Analyte detected in associated blank; sample concentration greater than five times the blank concentration
RS	RS-040106-1300	01/04/06	SW-846 8290	1,2,3,4,6,7,8-Heptachlorodibenzofuran	24	pg/g	LB	0 29 T	pg/g	B	None	Analyte detected in associated blank; sample concentration greater than five times the blank concentration
RS	RS-040106-1300	01/04/06	SW-846 8290	1,2,3,4,7,8-Hexachlorodibenzo-p-dioxin	3 0 T	pg/g	IAR	1 47	N/A	J	None	Datum is estimated, bias unknown; ion abundance ratio outside acceptance criteria
RS	RS-040106-1300	01/04/06	SW-846 8290	1,2,3,7,8,9-Hexachlorodibenzo-p-Dioxin	10 T	pg/g	LB	0 16 T	pg/g	B	None	Analyte detected in associated blank; sample concentration greater than five times the blank concentration
RS	RS-040106-1300	01/04/06	SW-846 8290	1,2,3,7,8,9-Hexachlorodibenzofuran	1 2 T	pg/g	IAR LB	2 14 0 22 T	N/A pg/g	JB	None	Datum is estimated, bias unknown; ion abundance ratio outside acceptance criteria Analyte detected in associated blank; sample concentration greater than five times the blank concentration

TABLE 1
DATA QUALIFIERS SUMMARY TABLE
DEMONSTRATION TESTING AND FULL-SCALE OPERATION OF THE BIOGENESIS SEDIMENT DECONTAMINATION PROCESS, KEASBEY, NEW JERSEY
(Page16 of 188)

Location Identification	Sample Identification	Sample Date	Analysis	Analyte	Sample Result	Sample Units	QC Type	QC Result	QC Units	Qualifier	Bias	Comment
RS	RS-040106-1300	01/04/06	SW-846 8290	1,2,3,7,8-Pentachlorodibenzo-p-dioxin	2 4 T	pg/g	IAR	1 86	N/A	J	None	Datum is estimated, bias unknown; ion abundance ratio outside acceptance criteria
RS	RS-040106-1300	01/04/06	SW-846 8290	1,2,3,7,8-Pentachlorodibenzofuran	2 9 T	pg/g	IAR LB	2 09 0 11 T	N/A pg/g	JB	None	Datum is estimated, bias unknown; ion abundance ratio outside acceptance criteria Analyte detected in associated blank; sample concentration greater than five times the blank concentration
RS	RS-040106-1300	01/04/06	SW-846 8290	2,3,4,6,7,8-Hexachlorodibenzofuran	3 4 T	pg/g	LB	0 15 T	pg/g	B	None	Analyte detected in associated blank; sample concentration greater than five times the blank concentration
RS	RS-040106-1300	01/04/06	SW-846 8290	2,3,4,7,8-Pentachlorodibenzofuran	8 3 T	pg/g	LB	0 11 T	pg/g	B	None	Analyte detected in associated blank; sample concentration greater than five times the blank concentration
RS	RS-040106-1300	01/04/06	SW-846 8290	2,3,7,8-Tetrachlorodibenzo-p-dioxin	1 8 T	pg/g	IAR	0 93	N/A	J	None	Datum is estimated, bias unknown; ion abundance ratio outside acceptance criteria
RS	RS-040106-1300	01/04/06	SW-846 8290	2,3,7,8-Tetrachlorodibenzofuran	7 8	pg/g	IAR	1 29	N/A	J	None	Datum is estimated, bias unknown; ion abundance ratio outside acceptance criteria
RS	RS-040106-1300	01/04/06	SW-846 8290	Octachlorodibenzo-p-dioxin	9600	pg/g	LB	1 8 T	pg/g	B	None	Analyte detected in associated blank; sample concentration greater than five times the blank concentration
RS	RS-040106-1300	01/04/06	SW-846 8290	Octachlorodibenzofuran	28 T	pg/g	LB	0 37 T	pg/g	B	None	Analyte detected in associated blank; sample concentration greater than five times the blank concentration
TS	TS-040106-1100	01/04/06	SW-846 8270 SIM	Pyrene	200	µg/kg	CVS	30	%	J	None	Datum is estimated, bias unknown; CVS %D outside acceptance criterion
TS	TS-040106-1100	01/04/06	SW-846 6010B	Zinc	140	mg/kg	LB	0 37 T	mg/kg	B	None	Analyte detected in associated blank; sample concentration greater than five times the blank concentration
TS	TS-040106-1100	01/04/06	SW-846 8081A	p,p'-DDT	2 7 TD	µg/kg	CONF	212 8	%	J	None	Datum is estimated, bias unknown; %D between primary and secondary GC columns outside acceptance criterion
TS	TS-040106-1100	01/04/06	SW-846 8082	2,2',3,4,4',5,5'-Heptachlorobiphenyl	0 85 TD	µg/kg	CONF	56 4	%	J	None	Datum is estimated, bias unknown; %D between primary and secondary GC columns outside acceptance criterion
TS	TS-040106-1100	01/04/06	SW-846 8082	2,2',3,4,5'-Pentachlorobiphenyl	1 8 D	µg/kg	CONF	123	%	J	None	Datum is estimated, bias unknown; %D between primary and secondary GC columns outside acceptance criterion
TS	TS-040106-1100	01/04/06	SW-846 8082	2,2',3,4,5,5'-Hexachlorobiphenyl	0 6 TD	µg/kg	CONF	220 8	%	J	None	Datum is estimated, bias unknown; %D between primary and secondary GC columns outside acceptance criterion
TS	TS-040106-1100	01/04/06	SW-846 8082	2,2',4,5,5'-Pentachlorobiphenyl	2 8 D	µg/kg	CONF	50 4	%	J	None	Datum is estimated, bias unknown; %D between primary and secondary GC columns outside acceptance criterion

TABLE 1
DATA QUALIFIERS SUMMARY TABLE
DEMONSTRATION TESTING AND FULL-SCALE OPERATION OF THE BIOGENESIS SEDIMENT DECONTAMINATION PROCESS, KEASBEY, NEW JERSEY
(Page17 of 188)

Location Identification	Sample Identification	Sample Date	Analysis	Analyte	Sample Result	Sample Units	QC Type	QC Result	QC Units	Qualifier	Bias	Comment
TS	TS-040106-1100	01/04/06	SW-846 8082	2,2',5-Trichlorobiphenyl	4 3 D	µg/kg	CONF	204 3	%	J	None	Datum is estimated, bias unknown; %D between primary and secondary GC columns outside acceptance criterion
TS	TS-040106-1100	01/04/06	SW-846 8082	2,3-Dichlorobiphenyl	1 4 D	µg/kg	CONF	136 9	%	J	None	Datum is estimated, bias unknown; %D between primary and secondary GC columns outside acceptance criterion
TS	TS-040106-1100	01/04/06	SW-846 8082	2,4,5-Trichlorobiphenyl	4 6 D	µg/kg	CONF	221 5	%	J	None	Datum is estimated, bias unknown; %D between primary and secondary GC columns outside acceptance criterion
TS	TS-040106-1100	01/04/06	SW-846 8290	1,2,3,4,6,7,8-Heptachlorodibenzofuran	0 86 T	pg/g	LB	0 16 T	pg/g	B	None	Analyte detected in associated blank; sample concentration greater than five times the blank concentration
TS	TS-040106-1100	01/04/06	SW-846 8290	1,2,3,4,7,8-Hexachlorodibenzofuran	0 49 T	pg/g	IAR	1 46	N/A	J	None	Datum is estimated, bias unknown; ion abundance ratio outside acceptance criteria
TS	TS-040106-1100	01/04/06	SW-846 8290	1,2,3,6,7,8-Hexachlorodibenzo-p-Dioxin	0 44 T	pg/g	IAR	1 54	N/A	J	None	Datum is estimated, bias unknown; ion abundance ratio outside acceptance criteria
TS	TS-040106-1100	01/04/06	SW-846 8290	Octachlorodibenzo-p-dioxin	270	pg/g	LB	0 87 T	pg/g	B	None	Analyte detected in associated blank; sample concentration greater than five times the blank concentration
TS	TS-040106-1100	01/04/06	SW-846 8290	Octachlorodibenzofuran	1 4 T	pg/g	LB	0 27 T	pg/g	B	None	Analyte detected in associated blank; sample concentration greater than five times the blank concentration
WS	WS-040106-1400	01/04/06	SW-846 8270 SIM	Pyrene	130	µg/kg	CVS	30	%	J	None	Datum is estimated, bias unknown; CVS %D outside acceptance criterion
WS	WS-040106-1400	01/04/06	SW-846 6010B	Zinc	329	mg/kg	LB	0 37 T	mg/kg	B	None	Analyte detected in associated blank; sample concentration greater than five times the blank concentration
WS	WS-040106-1400	01/04/06	SW-846 8082	2,2',3,3',4,4',5'-Heptachlorobiphenyl	0 59 TD	µg/kg	CONF	62 3	%	J	None	Datum is estimated, bias unknown; %D between primary and secondary GC columns outside acceptance criterion
WS	WS-040106-1400	01/04/06	SW-846 8082	2,2',3,4,4',5',5'-Heptachlorobiphenyl	0 95 TD	µg/kg	CONF	49 7	%	J	None	Datum is estimated, bias unknown; %D between primary and secondary GC columns outside acceptance criterion
WS	WS-040106-1400	01/04/06	SW-846 8082	2,2',3,4,5'-Pentachlorobiphenyl	2 2 D	µg/kg	CONF	122 7	%	J	None	Datum is estimated, bias unknown; %D between primary and secondary GC columns outside acceptance criterion
WS	WS-040106-1400	01/04/06	SW-846 8082	2,2',3,4,5',5'-Hexachlorobiphenyl	0 53 TD	µg/kg	CONF	283 4	%	J	None	Datum is estimated, bias unknown; %D between primary and secondary GC columns outside acceptance criterion
WS	WS-040106-1400	01/04/06	SW-846 8082	2,2',4,5',5'-Pentachlorobiphenyl	3 4 D	µg/kg	CONF	48 4	%	J	None	Datum is estimated, bias unknown; %D between primary and secondary GC columns outside acceptance criterion
WS	WS-040106-1400	01/04/06	SW-846 8082	2,2',5-Trichlorobiphenyl	6 9 D	µg/kg	CONF	45 5	%	J	None	Datum is estimated, bias unknown; %D between primary and secondary GC columns outside acceptance criterion

TABLE 1
DATA QUALIFIERS SUMMARY TABLE
DEMONSTRATION TESTING AND FULL-SCALE OPERATION OF THE BIOGENESIS SEDIMENT DECONTAMINATION PROCESS, KEASBEY, NEW JERSEY
(Page18 of 188)

Location Identification	Sample Identification	Sample Date	Analysis	Analyte	Sample Result	Sample Units	QC Type	QC Result	QC Units	Qualifier	Bias	Comment
WS	WS-040106-1400	01/04/06	SW-846 8082	2,3-Dichlorobiphenyl	0 73 TD	µg/kg	CONF	372 8	%	J	None	Datum is estimated, bias unknown; %D between primary and secondary GC columns outside acceptance criterion
WS	WS-040106-1400	01/04/06	SW-846 8082	2,4,5-Trichlorobiphenyl	6 2 D	µg/kg	CONF	362 7	%	J	None	Datum is estimated, bias unknown; %D between primary and secondary GC columns outside acceptance criterion
WS	WS-040106-1400	01/04/06	SW-846 8082	2-Chlorobiphenyl	4 TD	µg/kg	CONF	1000	%	J	None	Datum is estimated, bias unknown; %D between primary and secondary GC columns outside acceptance criterion
WS	WS-040106-1400	01/04/06	SW-846 8270C	1,4-Dichlorobenzene	<2100 D	µg/kg	TUNE	12:52	hours	R	None	Sample analyzed outside of 12-hour injection window
WS	WS-040106-1400	01/04/06	SW-846 8270C	2,4,5-Trichlorophenol	<2100 D	µg/kg	TUNE	12:52	hours	R	None	Sample analyzed outside of 12-hour injection window
WS	WS-040106-1400	01/04/06	SW-846 8270C	2,4,6-Trichlorophenol	<2100 D	µg/kg	TUNE	12:52	hours	R	None	Sample analyzed outside of 12-hour injection window
WS	WS-040106-1400	01/04/06	SW-846 8270C	2,4-Dinitrotoluene	<2100 D	µg/kg	TUNE	12:52	hours	R	None	Sample analyzed outside of 12-hour injection window
WS	WS-040106-1400	01/04/06	SW-846 8270C	2-Methylphenol (o-Cresol)	<2100 D	µg/kg	TUNE	12:52	hours	R	None	Sample analyzed outside of 12-hour injection window
WS	WS-040106-1400	01/04/06	SW-846 8270C	Acenaphthene	<2100 D	µg/kg	TUNE	12:52	hours	R	None	Sample analyzed outside of 12-hour injection window
WS	WS-040106-1400	01/04/06	SW-846 8270C	Acenaphthylene	<2100 D	µg/kg	TUNE	12:52	hours	R	None	Sample analyzed outside of 12-hour injection window
WS	WS-040106-1400	01/04/06	SW-846 8270C	Anthracene	<2100 D	µg/kg	TUNE	12:52	hours	R	None	Sample analyzed outside of 12-hour injection window
WS	WS-040106-1400	01/04/06	SW-846 8270C	Benzo(a)anthracene	68 TD	µg/kg	TUNE	12:52	hours	R	None	Sample analyzed outside of 12-hour injection window
WS	WS-040106-1400	01/04/06	SW-846 8270C	Benzo(a)pyrene	57 TD	µg/kg	TUNE	12:52	hours	R	None	Sample analyzed outside of 12-hour injection window
WS	WS-040106-1400	01/04/06	SW-846 8270C	Benzo(b)fluoranthene	65 TD	µg/kg	TUNE	12:52	hours	R	None	Sample analyzed outside of 12-hour injection window
WS	WS-040106-1400	01/04/06	SW-846 8270C	Benzo(g,h,i)perylene	49 TD	µg/kg	TUNE	12:52	hours	R	None	Sample analyzed outside of 12-hour injection window
WS	WS-040106-1400	01/04/06	SW-846 8270C	Benzo(k)fluoranthene	<2100 D	µg/kg	TUNE	12:52	hours	R	None	Sample analyzed outside of 12-hour injection window
WS	WS-040106-1400	01/04/06	SW-846 8270C	Chrysene	59 TD	µg/kg	TUNE	12:52	hours	R	None	Sample analyzed outside of 12-hour injection window
WS	WS-040106-1400	01/04/06	SW-846 8270C	3/4-Methylphenols (m & p Cresols)	<2100 D	µg/kg	TUNE	12:52	hours	R	None	Sample analyzed outside of 12-hour injection window
WS	WS-040106-1400	01/04/06	SW-846 8270C	Dibenz(a,h)anthracene	<2100 D	µg/kg	TUNE	12:52	hours	R	None	Sample analyzed outside of 12-hour injection window
WS	WS-040106-1400	01/04/06	SW-846 8270C	Fluoranthene	120 TD	µg/kg	TUNE	12:52	hours	R	None	Sample analyzed outside of 12-hour injection window
WS	WS-040106-1400	01/04/06	SW-846 8270C	Fluorene	<2100 D	µg/kg	TUNE	12:52	hours	R	None	Sample analyzed outside of 12-hour injection window
WS	WS-040106-1400	01/04/06	SW-846 8270C	Hexachlorobenzene	<2100 D	µg/kg	TUNE	12:52	hours	R	None	Sample analyzed outside of 12-hour injection window
WS	WS-040106-1400	01/04/06	SW-846 8270C	Hexachlorobutadiene	<2100 D	µg/kg	TUNE	12:52	hours	R	None	Sample analyzed outside of 12-hour injection window
WS	WS-040106-1400	01/04/06	SW-846 8270C	Hexachloroethane	<2100 D	µg/kg	TUNE	12:52	hours	R	None	Sample analyzed outside of 12-hour injection window
WS	WS-040106-1400	01/04/06	SW-846 8270C	Indeno(1,2,3-c,d)pyrene	44 TD	µg/kg	TUNE	12:52	hours	R	None	Sample analyzed outside of 12-hour injection window

TABLE 1
DATA QUALIFIERS SUMMARY TABLE
DEMONSTRATION TESTING AND FULL-SCALE OPERATION OF THE BIOGENESIS SEDIMENT DECONTAMINATION PROCESS, KEASBEY, NEW JERSEY
(Page19 of 188)

Location Identification	Sample Identification	Sample Date	Analysis	Analyte	Sample Result	Sample Units	QC Type	QC Result	QC Units	Qualifier	Bias	Comment
WS	WS-040106-1400	01/04/06	SW-846 8270C	Naphthalene	<2100 D	µg/kg	TUNE	12:52	hours	R	None	Sample analyzed outside of 12-hour injection window
WS	WS-040106-1400	01/04/06	SW-846 8270C	Nitrobenzene	<2100 D	µg/kg	TUNE	12:52	hours	R	None	Sample analyzed outside of 12-hour injection window
WS	WS-040106-1400	01/04/06	SW-846 8270C	Pentachlorophenol	<10000 D	µg/kg	TUNE	12:52	hours	R	None	Sample analyzed outside of 12-hour injection window
WS	WS-040106-1400	01/04/06	SW-846 8270C	Pyrene	130 TD	µg/kg	TUNE	12:52	hours	R	None	Sample analyzed outside of 12-hour injection window
WS	WS-040106-1400	01/04/06	SW-846 8290	1,2,3,4,6,7,8-Heptachlorodibenzofuran	2.5 T	pg/g	IAR LB	1.72 0.16 T	N/A pg/g	JB	None	Datum is estimated, bias unknown; ion abundance ratio outside acceptance criteria. Analyte detected in associated blank; sample concentration greater than five times the blank concentration.
WS	WS-040106-1400	01/04/06	SW-846 8290	1,2,3,4,7,8-Hexachlorodibenzofuran	0.63 T	pg/g	IAR	1.7	N/A	J	None	Datum is estimated, bias unknown; ion abundance ratio outside acceptance criteria.
WS	WS-040106-1400	01/04/06	SW-846 8290	2,3,7,8-Tetrachlorodibenzofuran	0.52 T	pg/g	IAR	0.53	N/A	J	None	Datum is estimated, bias unknown; ion abundance ratio outside acceptance criteria.
WS	WS-040106-1400	01/04/06	SW-846 8290	Octachlorodibenzo-p-dioxin	730	pg/g	LB	0.87 T	pg/g	B	None	Analyte detected in associated blank; sample concentration greater than five times the blank concentration.
WS	WS-040106-1400	01/04/06	SW-846 8290	Octachlorodibenzofuran	3.2 T	pg/g	IAR LB	0.74 0.27 T	N/A pg/g	JB	None	Datum is estimated, bias unknown; ion abundance ratio outside acceptance criteria. Analyte detected in associated blank; sample concentration greater than five times the blank concentration.
RS	RS-050106-1500	01/05/06	SW-846 8270 SIM	Pyrene	1000	µg/kg	CVS	32.2	%	J	None	Datum is estimated, bias unknown; CVS %D outside acceptance criterion.
RS	RS-050106-1500	01/05/06	SW-846 6010B	Chromium, total	48.2	mg/kg	LB	0.099 T	mg/kg	B	None	Analyte detected in associated blank; sample concentration greater than five times the blank concentration.
RS	RS-050106-1500	01/05/06	SW-846 6010B	Zinc	206	mg/kg	LB	0.29 T	mg/kg	B	None	Analyte detected in associated blank; sample concentration greater than five times the blank concentration.
RS	RS-050106-1500	01/05/06	SW-846 8081A	Aldrin	5.7	µg/kg	CONF	117.3	%	J	None	Datum is estimated, bias unknown; %D between primary and secondary GC columns outside acceptance criterion.
RS	RS-050106-1500	01/05/06	SW-846 8081A	Alpha BHC (alpha Hexachlorocyclohexane)	0.51 T	µg/kg	CONF	304.7	%	J	None	Datum is estimated, bias unknown; %D between primary and secondary GC columns outside acceptance criterion.
RS	RS-050106-1500	01/05/06	SW-846 8081A	Alpha-Chlordane	3.1 T	µg/kg	CONF	79.9	%	J	None	Datum is estimated, bias unknown; %D between primary and secondary GC columns outside acceptance criterion.
RS	RS-050106-1500	01/05/06	SW-846 8081A	Endosulfan sulfate	0.83 T	µg/kg	CONF	140.7	%	J	None	Datum is estimated, bias unknown; %D between primary and secondary GC columns outside acceptance criterion.
RS	RS-050106-1500	01/05/06	SW-846 8081A	Gamma-Chlordane	0.85 T	µg/kg	CONF	1000	%	J	None	Datum is estimated, bias unknown; %D between primary and secondary GC columns outside acceptance criterion.

TABLE 1
DATA QUALIFIERS SUMMARY TABLE
DEMONSTRATION TESTING AND FULL-SCALE OPERATION OF THE BIOGENESIS SEDIMENT DECONTAMINATION PROCESS, KEASBEY, NEW JERSEY
(Page20 of 188)

Location Identification	Sample Identification	Sample Date	Analysis	Analyte	Sample Result	Sample Units	QC Type	QC Result	QC Units	Qualifier	Bias	Comment
RS	RS-050106-1500	01/05/06	SW-846 8081A	Heptachlor epoxide	0.64	T µg/kg	CONF	333	%	J	None	Datum is estimated, bias unknown; %D between primary and secondary GC columns outside acceptance criterion
RS	RS-050106-1500	01/05/06	SW-846 8081A	p,p'-DDT	8.3	µg/kg	CONF	46.4	%	J	None	Datum is estimated, bias unknown; %D between primary and secondary GC columns outside acceptance criterion
RS	RS-050106-1500	01/05/06	SW-846 8082	2,2',3,4,4',5,5'-Heptachlorobiphenyl	0.86	µg/kg	CONF	60.3	%	J	None	Datum is estimated, bias unknown; %D between primary and secondary GC columns outside acceptance criterion
RS	RS-050106-1500	01/05/06	SW-846 8082	2,2',3,4,5'-Pentachlorobiphenyl	1.6	µg/kg	CONF	119.1	%	J	None	Datum is estimated, bias unknown; %D between primary and secondary GC columns outside acceptance criterion
RS	RS-050106-1500	01/05/06	SW-846 8082	2,2',3,4,5,5'-Hexachlorobiphenyl	0.45	T µg/kg	CONF	291	%	J	None	Datum is estimated, bias unknown; %D between primary and secondary GC columns outside acceptance criterion
RS	RS-050106-1500	01/05/06	SW-846 8082	2,2',5-Trichlorobiphenyl	4.1	µg/kg	CONF	118.2	%	J	None	Datum is estimated, bias unknown; %D between primary and secondary GC columns outside acceptance criterion
RS	RS-050106-1500	01/05/06	SW-846 8082	2,3-Dichlorobiphenyl	1.1	µg/kg	CONF	182.1	%	J	None	Datum is estimated, bias unknown; %D between primary and secondary GC columns outside acceptance criterion
RS	RS-050106-1500	01/05/06	SW-846 8082	2,4,5-Trichlorobiphenyl	4.5	µg/kg	CONF	162.3	%	J	None	Datum is estimated, bias unknown; %D between primary and secondary GC columns outside acceptance criterion
RS	RS-050106-1500	01/05/06	SW-846 8082	2-Chlorobiphenyl	3.1	T µg/kg	CONF	1000	%	J	None	Datum is estimated, bias unknown; %D between primary and secondary GC columns outside acceptance criterion
RS	RS-050106-1500	01/05/06	SW-846 8290	1,2,3,4,6,7,8-Heptachlorodibenzo-p-dioxin	170	pg/g	LB	0.36	T pg/g	B	None	Analyte detected in associated blank; sample concentration greater than five times the blank concentration
RS	RS-050106-1500	01/05/06	SW-846 8290	1,2,3,4,6,7,8-Heptachlorodibenzofuran	23	pg/g	LB	0.29	T pg/g	B	None	Analyte detected in associated blank; sample concentration greater than five times the blank concentration
RS	RS-050106-1500	01/05/06	SW-846 8290	1,2,3,6,7,8-Hexachlorodibenzo-p-Dioxin	6.3	T pg/g	IAR	1.51	N/A	J	None	Datum is estimated, bias unknown; ion abundance ratio outside acceptance criteria
RS	RS-050106-1500	01/05/06	SW-846 8290	1,2,3,7,8,9-Hexachlorodibenzo-p-Dioxin	7.7	T pg/g	IAR LB	1.04 0.16	N/A T pg/g	JB	None	Datum is estimated, bias unknown; ion abundance ratio outside acceptance criteria Analyte detected in associated blank; sample concentration greater than five times the blank concentration
RS	RS-050106-1500	01/05/06	SW-846 8290	1,2,3,7,8,9-Hexachlorodibenzofuran	0.62	T pg/g	IAR LB	0.96 0.22	N/A T pg/g	JUB	None	Datum is estimated, bias unknown; ion abundance ratio outside acceptance criteria Analyte considered not detected, analyte detected in associated blank; sample concentration less than five times the blank concentration
RS	RS-050106-1500	01/05/06	SW-846 8290	1,2,3,7,8-Pentachlorodibenzofuran	2.1	T pg/g	LB	0.11	T pg/g	B	None	Analyte detected in associated blank; sample concentration greater than five times the blank concentration

TABLE 1
DATA QUALIFIERS SUMMARY TABLE
DEMONSTRATION TESTING AND FULL-SCALE OPERATION OF THE BIOGENESIS SEDIMENT DECONTAMINATION PROCESS, KEASBEY, NEW JERSEY
(Page21 of 188)

Location Identification	Sample Identification	Sample Date	Analysis	Analyte	Sample Result	Sample Units	QC Type	QC Result	QC Units	Qualifier	Bias	Comment
RS	RS-050106-1500	01/05/06	SW-846 8290	2,3,4,6,7,8-Hexachlorodibenzofuran	2.4 T	pg/g	LB	0.15 T	pg/g	B	None	Analyte detected in associated blank; sample concentration greater than five times the blank concentration
RS	RS-050106-1500	01/05/06	SW-846 8290	2,3,4,7,8-Pentachlorodibenzofuran	4.2 T	pg/g	LB	0.11 T	pg/g	B	None	Analyte detected in associated blank; sample concentration greater than five times the blank concentration
RS	RS-050106-1500	01/05/06	SW-846 8290	Octachlorodibenzo-p-dioxin	9700	pg/g	LB	1.8 T	pg/g	B	None	Analyte detected in associated blank; sample concentration greater than five times the blank concentration
RS	RS-050106-1500	01/05/06	SW-846 8290	Octachlorodibenzofuran	22 T	pg/g	LB	0.37 T	pg/g	B	None	Analyte detected in associated blank; sample concentration greater than five times the blank concentration
TS	TS-050106-1505	01/05/06	SW-846 8270 SIM	Pyrene	490	µg/kg	CVS	32.2	%	J	None	Datum is estimated, bias unknown; CVS %D outside acceptance criterion
TS	TS-050106-1505	01/05/06	SW-846 6010B	Chromium, total	29.7	mg/kg	LB	0.099 T	mg/kg	B	None	Analyte detected in associated blank; sample concentration greater than five times the blank concentration
TS	TS-050106-1505	01/05/06	SW-846 6010B	Zinc	142	mg/kg	LB	0.29 T	mg/kg	B	None	Analyte detected in associated blank; sample concentration greater than five times the blank concentration
TS	TS-050106-1505	01/05/06	SW-846 8081A	Alpha BHC (alpha Hexachlorocyclohexane)	0.27 T	µg/kg	CONF	169.4	%	J	None	Datum is estimated, bias unknown; %D between primary and secondary GC columns outside acceptance criterion
TS	TS-050106-1505	01/05/06	SW-846 8081A	Dieldrin	1.4 T	µg/kg	CONF	143.9	%	J	None	Datum is estimated, bias unknown; %D between primary and secondary GC columns outside acceptance criterion
TS	TS-050106-1505	01/05/06	SW-846 8081A	Gamma-Chlordane	0.64 T	µg/kg	CONF	375.3	%	J	None	Datum is estimated, bias unknown; %D between primary and secondary GC columns outside acceptance criterion
TS	TS-050106-1505	01/05/06	SW-846 8081A	Heptachlor epoxide	0.94 T	µg/kg	CONF	123.1	%	J	None	Datum is estimated, bias unknown; %D between primary and secondary GC columns outside acceptance criterion
TS	TS-050106-1505	01/05/06	SW-846 8081A	p,p'-DDE	3.5	µg/kg	CONF	69	%	J	None	Datum is estimated, bias unknown; %D between primary and secondary GC columns outside acceptance criterion
TS	TS-050106-1505	01/05/06	SW-846 8082	2,2',3,4,4',5,5'-Heptachlorobiphenyl	0.85 TD	µg/kg	CONF	48	%	J	None	Datum is estimated, bias unknown; %D between primary and secondary GC columns outside acceptance criterion
TS	TS-050106-1505	01/05/06	SW-846 8082	2,2',3,4,5'-Pentachlorobiphenyl	1.8 D	µg/kg	CONF	120.7	%	J	None	Datum is estimated, bias unknown; %D between primary and secondary GC columns outside acceptance criterion
TS	TS-050106-1505	01/05/06	SW-846 8082	2,2',3,4,5,5'-Hexachlorobiphenyl	0.49 TD	µg/kg	CONF	298.3	%	J	None	Datum is estimated, bias unknown; %D between primary and secondary GC columns outside acceptance criterion

TABLE 1
DATA QUALIFIERS SUMMARY TABLE
DEMONSTRATION TESTING AND FULL-SCALE OPERATION OF THE BIOGENESIS SEDIMENT DECONTAMINATION PROCESS, KEASBEY, NEW JERSEY
(Page22 of 188)

Location Identification	Sample Identification	Sample Date	Analysis	Analyte	Sample Result	Sample Units	QC Type	QC Result	QC Units	Qualifier	Bias	Comment
TS	TS-050106-1505	01/05/06	SW-846 8082	2,2',4,5,5'-Pentachlorobiphenyl	2 8 D	µg/kg	CONF	41 9	%	J	None	Datum is estimated, bias unknown; %D between primary and secondary GC columns outside acceptance criterion
TS	TS-050106-1505	01/05/06	SW-846 8082	2,2',5-Trichlorobiphenyl	4 5 D	µg/kg	CONF	153 2	%	J	None	Datum is estimated, bias unknown; %D between primary and secondary GC columns outside acceptance criterion
TS	TS-050106-1505	01/05/06	SW-846 8082	2,3-Dichlorobiphenyl	1 6 D	µg/kg	CONF	84 3	%	J	None	Datum is estimated, bias unknown; %D between primary and secondary GC columns outside acceptance criterion
TS	TS-050106-1505	01/05/06	SW-846 8082	2,4,5-Trichlorobiphenyl	4 8 D	µg/kg	CONF	113 1	%	J	None	Datum is estimated, bias unknown; %D between primary and secondary GC columns outside acceptance criterion
TS	TS-050106-1505	01/05/06	SW-846 8082	2-Chlorobiphenyl	5 3 TD	µg/kg	CONF	506 1	%	J	None	Datum is estimated, bias unknown; %D between primary and secondary GC columns outside acceptance criterion
TS	TS-050106-1505	01/05/06	SW-846 8290	1,2,3,4,6,7,8-Heptachlorodibenzofuran	4 3 T	pg/g	LB	0 16 T	pg/g	B	None	Analyte detected in associated blank; sample concentration greater than five times the blank concentration
TS	TS-050106-1505	01/05/06	SW-846 8290	1,2,3,6,7,8-Hexachlorodibenzo-p-Dioxin	1 7 T	pg/g	IAR	1 02	N/A	J	None	Datum is estimated, bias unknown; ion abundance ratio outside acceptance criteria
TS	TS-050106-1505	01/05/06	SW-846 8290	1,2,3,7,8-Pentachlorodibenzofuran	0 60 T	pg/g	IAR	1 29	N/A	J	None	Datum is estimated, bias unknown; ion abundance ratio outside acceptance criteria
TS	TS-050106-1505	01/05/06	SW-846 8290	2,3,7,8-Tetrachlorodibenzo-p-dioxin	0 33 T	pg/g	IAR	1 1	N/A	J	None	Datum is estimated, bias unknown; ion abundance ratio outside acceptance criteria
TS	TS-050106-1505	01/05/06	SW-846 8290	Octachlorodibenzo-p-dioxin	960	pg/g	LB	0 87 T	pg/g	B	None	Analyte detected in associated blank; sample concentration greater than five times the blank concentration
TS	TS-050106-1505	01/05/06	SW-846 8290	Octachlorodibenzofuran	6 3 T	pg/g	IAR LB	0 74 0 27 T	N/A pg/g	JB	None	Datum is estimated, bias unknown; ion abundance ratio outside acceptance criteria Analyte detected in associated blank; sample concentration greater than five times the blank concentration
WS	WS-050106-1510	01/05/06	SW-846 8270 SIM	Pyrene	110	µg/kg	CVS	32 2	%	J	None	Datum is estimated, bias unknown; CVS %D outside acceptance criterion
WS	WS-050106-1510	01/05/06	SW-846 6010B	Chromium, total	80 2	mg/kg	LB	0 099 T	mg/kg	B	None	Analyte detected in associated blank; sample concentration greater than five times the blank concentration
WS	WS-050106-1510	01/05/06	SW-846 6010B	Zinc	321	mg/kg	LB	0 29 T	mg/kg	B	None	Analyte detected in associated blank; sample concentration greater than five times the blank concentration
WS	WS-050106-1510	01/05/06	SW-846 8081A	Aldrin	1 6 T	µg/kg	CONF	139 8	%	J	None	Datum is estimated, bias unknown; %D between primary and secondary GC columns outside acceptance criterion
WS	WS-050106-1510	01/05/06	SW-846 8081A	Alpha BHC (alpha Hexachlorocyclohexane)	0 57 T	µg/kg	CONF	65 4	%	J	None	Datum is estimated, bias unknown; %D between primary and secondary GC columns outside acceptance criterion

TABLE 1
DATA QUALIFIERS SUMMARY TABLE
DEMONSTRATION TESTING AND FULL-SCALE OPERATION OF THE BIOGENESIS SEDIMENT DECONTAMINATION PROCESS, KEASBEY, NEW JERSEY
(Page23 of 188)

Location Identification	Sample Identification	Sample Date	Analysis	Analyte	Sample Result	Sample Units	QC Type	QC Result	QC Units	Qualifier	Bias	Comment
WS	WS-050106-1510	01/05/06	SW-846 8081A	Alpha-Chlordane	3 4 T	µg/kg	CONF	42 6	%	J	None	Datum is estimated, bias unknown; %D between primary and secondary GC columns outside acceptance criterion
WS	WS-050106-1510	01/05/06	SW-846 8081A	Heptachlor epoxide	0 95 T	µg/kg	CONF	230 8	%	J	None	Datum is estimated, bias unknown; %D between primary and secondary GC columns outside acceptance criterion
WS	WS-050106-1510	01/05/06	SW-846 8081A	p,p'-DDD	2 4 T	µg/kg	CONF	54 7	%	J	None	Datum is estimated, bias unknown; %D between primary and secondary GC columns outside acceptance criterion
WS	WS-050106-1510	01/05/06	SW-846 8081A	p,p'-DDT	2 8 T	µg/kg	CONF	255 2	%	J	None	Datum is estimated, bias unknown; %D between primary and secondary GC columns outside acceptance criterion
WS	WS-050106-1510	01/05/06	SW-846 8082	2,2',3,4,4',5,5'-Heptachlorobiphenyl	0 42 T	µg/kg	CONF	79 6	%	J	None	Datum is estimated, bias unknown; %D between primary and secondary GC columns outside acceptance criterion
WS	WS-050106-1510	01/05/06	SW-846 8082	2,2',3,4,5'-Pentachlorobiphenyl	1 1	µg/kg	CONF	115 5	%	J	None	Datum is estimated, bias unknown; %D between primary and secondary GC columns outside acceptance criterion
WS	WS-050106-1510	01/05/06	SW-846 8082	2,2',3,4,5,5'-Hexachlorobiphenyl	0 26 T	µg/kg	CONF	285 7	%	J	None	Datum is estimated, bias unknown; %D between primary and secondary GC columns outside acceptance criterion
WS	WS-050106-1510	01/05/06	SW-846 8082	2,2',5-Trichlorobiphenyl	3 1	µg/kg	CONF	55	%	J	None	Datum is estimated, bias unknown; %D between primary and secondary GC columns outside acceptance criterion
WS	WS-050106-1510	01/05/06	SW-846 8082	2,3-Dichlorobiphenyl	0 39 T	µg/kg	CONF	313 2	%	J	None	Datum is estimated, bias unknown; %D between primary and secondary GC columns outside acceptance criterion
WS	WS-050106-1510	01/05/06	SW-846 8082	2,4,5-Trichlorobiphenyl	2 9	µg/kg	CONF	570 2	%	J	None	Datum is estimated, bias unknown; %D between primary and secondary GC columns outside acceptance criterion
WS	WS-050106-1510	01/05/06	SW-846 8290	1,2,3,4,6,7,8-Heptachlorodibenzofuran	1 7 T	pg/g	IAR LB	4 1 0 16 T	N/A pg/g	JB	None	Datum is estimated, bias unknown; ion abundance ratio outside acceptance criteria Analyte detected in associated blank; sample concentration greater than five times the blank concentration
WS	WS-050106-1510	01/05/06	SW-846 8290	1,2,3,4,7,8-Hexachlorodibenzofuran	0 51 T	pg/g	IAR	1 47	N/A	J	None	Datum is estimated, bias unknown; ion abundance ratio outside acceptance criteria
WS	WS-050106-1510	01/05/06	SW-846 8290	1,2,3,6,7,8-Hexachlorodibenzo-p-Dioxin	0 68 T	pg/g	IAR	0 84	N/A	J	None	Datum is estimated, bias unknown; ion abundance ratio outside acceptance criteria
WS	WS-050106-1510	01/05/06	SW-846 8290	2,3,4,7,8-Pentachlorodibenzofuran	0 34 T	pg/g	IAR	1 19	N/A	J	None	Datum is estimated, bias unknown; ion abundance ratio outside acceptance criteria
WS	WS-050106-1510	01/05/06	SW-846 8290	2,3,7,8-Tetrachlorodibenzofuran	0 66 T	pg/g	IAR	0 55	N/A	J	None	Datum is estimated, bias unknown; ion abundance ratio outside acceptance criteria
WS	WS-050106-1510	01/05/06	SW-846 8290	Octachlorodibenzo-p-dioxin	570	pg/g	LB	0 87 T	pg/g	B	None	Analyte detected in associated blank; sample concentration greater than five times the blank concentration

TABLE 1
DATA QUALIFIERS SUMMARY TABLE
DEMONSTRATION TESTING AND FULL-SCALE OPERATION OF THE BIOGENESIS SEDIMENT DECONTAMINATION PROCESS, KEASBEY, NEW JERSEY
(Page24 of 188)

Location Identification	Sample Identification	Sample Date	Analysis	Analyte	Sample Result	Sample Units	QC Type	QC Result	QC Units	Qualifier	Bias	Comment
WS	WS-050106-1510	01/05/06	SW-846 8290	Octachlorodibenzofuran	2.7 T	pg/g	LB	0.27 T	pg/g	B	None	Analyte detected in associated blank; sample concentration greater than five times the blank concentration
RS	RS-060106-1531	01/06/06	SW-846 8270 SIM	Pyrene	230	µg/kg	CVS	29.9	%	J	None	Datum is estimated, bias unknown; CVS %D outside acceptance criterion
RS	RS-060106-1531	01/06/06	SW-846 6010B	Chromium, total	183	mg/kg	LB	0.099 T	mg/kg	B	None	Analyte detected in associated blank; sample concentration greater than five times the blank concentration
RS	RS-060106-1531	01/06/06	SW-846 6010B	Zinc	773	mg/kg	MS SLD LB	66 12.7 0.29 T	% % mg/kg	JB	Low	Datum is estimated, possible low bias; MS recovery and serial dilution percent difference outside acceptance criteria. Analyte detected in associated blank; sample concentration greater than five times the blank concentration
RS	RS-060106-1531	01/06/06	SW-846 8081A	Beta endosulfan	4.2 T	µg/kg	CONF	81.4	%	J	None	Datum is estimated, bias unknown; %D between primary and secondary GC columns outside acceptance criterion
RS	RS-060106-1531	01/06/06	SW-846 8081A	Endrin	8.0 T	µg/kg	CONF	40.1	%	J	None	Datum is estimated, bias unknown; %D between primary and secondary GC columns outside acceptance criterion
RS	RS-060106-1531	01/06/06	SW-846 8081A	p,p'-DDD	3.9 T	µg/kg	CONF	187.4	%	J	None	Datum is estimated, bias unknown; %D between primary and secondary GC columns outside acceptance criterion
RS	RS-060106-1531	01/06/06	SW-846 8081A	p,p'-DDE	3.3 T	µg/kg	CONF	62.1	%	J	None	Datum is estimated, bias unknown; %D between primary and secondary GC columns outside acceptance criterion
RS	RS-060106-1531	01/06/06	SW-846 8082	2,2',3,4,5'-Pentachlorobiphenyl	1.5 T	µg/kg	CONF	101.3	%	J	None	Datum is estimated, bias unknown; %D between primary and secondary GC columns outside acceptance criterion
RS	RS-060106-1531	01/06/06	SW-846 8082	2,2',4,4',5,5'-Hexachlorobiphenyl	1.5 T	µg/kg	CONF	52.3	%	J	None	Datum is estimated, bias unknown; %D between primary and secondary GC columns outside acceptance criterion
RS	RS-060106-1531	01/06/06	SW-846 8082	2,2',5-Trichlorobiphenyl	3.7	µg/kg	CONF	66.1	%	J	None	Datum is estimated, bias unknown; %D between primary and secondary GC columns outside acceptance criterion
RS	RS-060106-1531	01/06/06	SW-846 8082	2,3-Dichlorobiphenyl	1.6 T	µg/kg	CONF	67.4	%	J	None	Datum is estimated, bias unknown; %D between primary and secondary GC columns outside acceptance criterion
RS	RS-060106-1531	01/06/06	SW-846 8082	2,4,5-Trichlorobiphenyl	3.6	µg/kg	CONF	1000	%	J	None	Datum is estimated, bias unknown; %D between primary and secondary GC columns outside acceptance criterion
RS	RS-060106-1531	01/06/06	SW-846 8290	1,2,3,4,6,7,8-Heptachlorodibenzo-p-dioxin	31	pg/g	LB	0.22 T	pg/g	B	None	Analyte detected in associated blank; sample concentration greater than five times the blank concentration
RS	RS-060106-1531	01/06/06	SW-846 8290	1,2,3,4,6,7,8-Heptachlorodibenzofuran	3.8 T	pg/g	IAR LB	1.33 0.23 T	N/A pg/g	JB	None	Datum is estimated, bias unknown; ion abundance ratio outside acceptance criteria. Analyte detected in associated blank; sample concentration greater than five times the blank concentration

TABLE 1
DATA QUALIFIERS SUMMARY TABLE
DEMONSTRATION TESTING AND FULL-SCALE OPERATION OF THE BIOGENESIS SEDIMENT DECONTAMINATION PROCESS, KEASBEY, NEW JERSEY
(Page25 of 188)

Location Identification	Sample Identification	Sample Date	Analysis	Analyte	Sample Result	Sample Units	QC Type	QC Result	QC Units	Qualifier	Bias	Comment
RS	RS-060106-1531	01/06/06	SW-846 8290	1,2,3,4,7,8-Hexachlorodibenzofuran	1.1 T	pg/g	IAR	0.81	N/A	J	None	Datum is estimated, bias unknown; ion abundance ratio outside acceptance criteria
RS	RS-060106-1531	01/06/06	SW-846 8290	1,2,3,6,7,8-Hexachlorodibenzo-p-Dioxin	1.2 T	pg/g	IAR	0.91	N/A	J	None	Datum is estimated, bias unknown; ion abundance ratio outside acceptance criteria
RS	RS-060106-1531	01/06/06	SW-846 8290	1,2,3,7,8,9-Hexachlorodibenzo-p-Dioxin	1.2 T	pg/g	IAR	0.99	N/A	J	None	Datum is estimated, bias unknown; ion abundance ratio outside acceptance criteria
RS	RS-060106-1531	01/06/06	SW-846 8290	2,3,4,6,7,8-Hexachlorodibenzofuran	0.49 T	pg/g	IAR	0.91	N/A	J	None	Datum is estimated, bias unknown; ion abundance ratio outside acceptance criteria
RS	RS-060106-1531	01/06/06	SW-846 8290	2,3,4,7,8-Pentachlorodibenzofuran	0.88 T	pg/g	PDE LB	N/A 0.13 T	N/A pg/g	JB	None	Datum is estimated, bias unknown; interfering polychlorinated diphenyl ether peak present. Analyte detected in associated blank; sample concentration greater than five times the blank concentration
RS	RS-060106-1531	01/06/06	SW-846 8290	Octachlorodibenzo-p-dioxin	1900	pg/g	LB	1.8 T	pg/g	B	None	Analyte detected in associated blank; sample concentration greater than five times the blank concentration
RS	RS-060106-1531	01/06/06	SW-846 8290	Octachlorodibenzofuran	4.3 T	pg/g	IAR	0.73	N/A	J	None	Datum is estimated, bias unknown; ion abundance ratio outside acceptance criteria
TS	TS-060106-1532	01/06/06	SW-846 8270 SIM	Pyrene	460	µg/kg	CVS	29.9	%	J	None	Datum is estimated, bias unknown; CVS %D outside acceptance criterion
TS	TS-060106-1532	01/06/06	SW-846 6010B	Chromium, total	28.8	mg/kg	LB	0.099 T	mg/kg	B	None	Analyte detected in associated blank; sample concentration greater than five times the blank concentration
TS	TS-060106-1532	01/06/06	SW-846 6010B	Zinc	138	mg/kg	LB	0.29 T	mg/kg	B	None	Analyte detected in associated blank; sample concentration greater than five times the blank concentration
TS	TS-060106-1532	01/06/06	SW-846 8081A	Alpha BHC (alpha Hexachlorocyclohexane)	4.4	µg/kg	CONF	377.8	%	J	None	Datum is estimated, bias unknown; %D between primary and secondary GC columns outside acceptance criterion
TS	TS-060106-1532	01/06/06	SW-846 8081A	alpha Endosulfan	3.3	µg/kg	CONF	285.8	%	J	None	Datum is estimated, bias unknown; %D between primary and secondary GC columns outside acceptance criterion
TS	TS-060106-1532	01/06/06	SW-846 8081A	Dieldrin	4.1	µg/kg	CONF	50.1	%	J	None	Datum is estimated, bias unknown; %D between primary and secondary GC columns outside acceptance criterion
TS	TS-060106-1532	01/06/06	SW-846 8081A	Endosulfan sulfate	1.3 T	µg/kg	CONF	181.4	%	J	None	Datum is estimated, bias unknown; %D between primary and secondary GC columns outside acceptance criterion
TS	TS-060106-1532	01/06/06	SW-846 8081A	Gamma-Chlordane	4.6	µg/kg	CONF	73.4	%	J	None	Datum is estimated, bias unknown; %D between primary and secondary GC columns outside acceptance criterion
TS	TS-060106-1532	01/06/06	SW-846 8082	2,2',3,4,4',5,5'-Heptachlorobiphenyl	0.71 D	µg/kg	CONF	67.2	%	J	None	Datum is estimated, bias unknown; %D between primary and secondary GC columns outside acceptance criterion

TABLE 1
DATA QUALIFIERS SUMMARY TABLE
DEMONSTRATION TESTING AND FULL-SCALE OPERATION OF THE BIOGENESIS SEDIMENT DECONTAMINATION PROCESS, KEASBEY, NEW JERSEY
(Page26 of 188)

Location Identification	Sample Identification	Sample Date	Analysis	Analyte	Sample Result	Sample Units	QC Type	QC Result	QC Units	Qualifier	Bias	Comment
TS	TS-060106-1532	01/06/06	SW-846 8082	2,2',3,4,5'-Pentachlorobiphenyl	1 6 D	µg/kg	CONF	106 9	%	J	None	Datum is estimated, bias unknown; %D between primary and secondary GC columns outside acceptance criterion
TS	TS-060106-1532	01/06/06	SW-846 8082	2,2',3,4,5,5'-Hexachlorobiphenyl	0 45 TD	µg/kg	CONF	263 8	%	J	None	Datum is estimated, bias unknown; %D between primary and secondary GC columns outside acceptance criterion
TS	TS-060106-1532	01/06/06	SW-846 8082	2,2',5-Trichlorobiphenyl	3 7 D	µg/kg	CONF	128 7	%	J	None	Datum is estimated, bias unknown; %D between primary and secondary GC columns outside acceptance criterion
TS	TS-060106-1532	01/06/06	SW-846 8082	2,3-Dichlorobiphenyl	1 2 D	µg/kg	CONF	101 7	%	J	None	Datum is estimated, bias unknown; %D between primary and secondary GC columns outside acceptance criterion
TS	TS-060106-1532	01/06/06	SW-846 8082	2,4,5-Trichlorobiphenyl	4 2 D	µg/kg	CONF	170 9	%	J	None	Datum is estimated, bias unknown; %D between primary and secondary GC columns outside acceptance criterion
TS	TS-060106-1532	01/06/06	SW-846 8082	2-Chlorobiphenyl	2 8 TD	µg/kg	CONF	1000	%	J	None	Datum is estimated, bias unknown; %D between primary and secondary GC columns outside acceptance criterion
TS	TS-060106-1532	01/06/06	SW-846 8290	1,2,3,4,6,7,8-Heptachlorodibenzo-p-dioxin	9 2	pg/g	LB	0 36 T	pg/g	B	None	Analyte detected in associated blank; sample concentration greater than five times the blank concentration
TS	TS-060106-1532	01/06/06	SW-846 8290	1,2,3,4,6,7,8-Heptachlorodibenzofuran	1 6 T	pg/g	LB	0 29 T	pg/g	B	None	Analyte detected in associated blank; sample concentration greater than five times the blank concentration
TS	TS-060106-1532	01/06/06	SW-846 8290	1,2,3,4,7,8-Hexachlorodibenzo-p-dioxin	0 31 T	pg/g	IAR	1 46	N/A	J	None	Datum is estimated, bias unknown; ion abundance ratio outside acceptance criteria
TS	TS-060106-1532	01/06/06	SW-846 8290	1,2,3,4,7,8-Hexachlorodibenzofuran	0 53 T	pg/g	IAR	1 83	N/A	J	None	Datum is estimated, bias unknown; ion abundance ratio outside acceptance criteria
TS	TS-060106-1532	01/06/06	SW-846 8290	1,2,3,6,7,8-Hexachlorodibenzo-p-Dioxin	0 59 T	pg/g	IAR	1 46	N/A	J	None	Datum is estimated, bias unknown; ion abundance ratio outside acceptance criteria
TS	TS-060106-1532	01/06/06	SW-846 8290	1,2,3,6,7,8-Hexachlorodibenzofuran	0 21 T	pg/g	IAR	2 24	N/A	J	None	Datum is estimated, bias unknown; ion abundance ratio outside acceptance criteria
TS	TS-060106-1532	01/06/06	SW-846 8290	1,2,3,7,8,9-Hexachlorodibenzo-p-Dioxin	0 76 T	pg/g	IAR LB	1 04 0 16 T	N/A pg/g	JUB	None	Datum is estimated, bias unknown; ion abundance ratio outside acceptance criteria Analyte considered not detected, analyte detected in associated blank; sample concentration less than five times the blank concentration
TS	TS-060106-1532	01/06/06	SW-846 8290	1,2,3,7,8-Pentachlorodibenzo-p-dioxin	0 21 T	pg/g	IAR	0 88	N/A	J	None	Datum is estimated, bias unknown; ion abundance ratio outside acceptance criteria
TS	TS-060106-1532	01/06/06	SW-846 8290	1,2,3,7,8-Pentachlorodibenzofuran	0 15 T	pg/g	IAR LB	0 78 0 11 T	N/A pg/g	JUB	None	Datum is estimated, bias unknown; ion abundance ratio outside acceptance criteria Analyte considered not detected, analyte detected in associated blank; sample concentration less than five times the blank concentration
TS	TS-060106-1532	01/06/06	SW-846 8290	2,3,4,7,8-Pentachlorodibenzofuran	0 60 T	pg/g	LB	0 11 T	pg/g	B	None	Analyte detected in associated blank; sample concentration greater than five times the blank concentration

TABLE 1
DATA QUALIFIERS SUMMARY TABLE
DEMONSTRATION TESTING AND FULL-SCALE OPERATION OF THE BIOGENESIS SEDIMENT DECONTAMINATION PROCESS, KEASBEY, NEW JERSEY
(Page27 of 188)

Location Identification	Sample Identification	Sample Date	Analysis	Analyte	Sample Result	Sample Units	QC Type	QC Result	QC Units	Qualifier	Bias	Comment
TS	TS-060106-1532	01/06/06	SW-846 8290	2,3,7,8-Tetrachlorodibenzofuran	0.49 T	pg/g	IAR	0.91	N/A	J	None	Datum is estimated, bias unknown; ion abundance ratio outside acceptance criteria
TS	TS-060106-1532	01/06/06	SW-846 8290	Octachlorodibenzo-p-dioxin	400	pg/g	LB	1.8 T	pg/g	B	None	Analyte detected in associated blank; sample concentration greater than five times the blank concentration
TS	TS-060106-1532	01/06/06	SW-846 8290	Octachlorodibenzofuran	2.3 T	pg/g	LB	0.37 T	pg/g	B	None	Analyte detected in associated blank; sample concentration greater than five times the blank concentration
WS	WS-060106-1533	01/06/06	SW-846 8270 SIM	Pyrene	84	µg/kg	CVS	29.9	%	J	None	Datum is estimated, bias unknown; CVS %D outside acceptance criterion
WS	WS-060106-1533	01/06/06	SW-846 6010B	Chromium, total	80.9	mg/kg	LB	0.099 T	mg/kg	B	None	Analyte detected in associated blank; sample concentration greater than five times the blank concentration
WS	WS-060106-1533	01/06/06	SW-846 6010B	Zinc	326	mg/kg	LB	0.29 T	mg/kg	B	None	Analyte detected in associated blank; sample concentration greater than five times the blank concentration
WS	WS-060106-1533	01/06/06	SW-846 8081A	Alpha BHC (alpha Hexachlorocyclohexane)	0.48 T	µg/kg	CONF	408.8	%	J	None	Datum is estimated, bias unknown; %D between primary and secondary GC columns outside acceptance criterion
WS	WS-060106-1533	01/06/06	SW-846 8081A	alpha Endosulfan	1.8 T	µg/kg	CONF	164.7	%	J	None	Datum is estimated, bias unknown; %D between primary and secondary GC columns outside acceptance criterion
WS	WS-060106-1533	01/06/06	SW-846 8081A	beta Endosulfan	6.6	µg/kg	CONF	42.4	%	J	None	Datum is estimated, bias unknown; %D between primary and secondary GC columns outside acceptance criterion
WS	WS-060106-1533	01/06/06	SW-846 8081A	Dieldrin	3.5 T	µg/kg	CONF	103.7	%	J	None	Datum is estimated, bias unknown; %D between primary and secondary GC columns outside acceptance criterion
WS	WS-060106-1533	01/06/06	SW-846 8081A	Gamma-Chlordane	2.0 T	µg/kg	CONF	51	%	J	None	Datum is estimated, bias unknown; %D between primary and secondary GC columns outside acceptance criterion
WS	WS-060106-1533	01/06/06	SW-846 8081A	Heptachlor epoxide	0.84 T	µg/kg	CONF	206.2	%	J	None	Datum is estimated, bias unknown; %D between primary and secondary GC columns outside acceptance criterion
WS	WS-060106-1533	01/06/06	SW-846 8081A	p,p'-DDD	6.3	µg/kg	CONF	71.1	%	J	None	Datum is estimated, bias unknown; %D between primary and secondary GC columns outside acceptance criterion
WS	WS-060106-1533	01/06/06	SW-846 8081A	p,p'-DDE	4.6 T	µg/kg	CONF	98.1	%	J	None	Datum is estimated, bias unknown; %D between primary and secondary GC columns outside acceptance criterion
WS	WS-060106-1533	01/06/06	SW-846 8081A	p,p'-DDT	8.4	µg/kg	CONF	53.3	%	J	None	Datum is estimated, bias unknown; %D between primary and secondary GC columns outside acceptance criterion
WS	WS-060106-1533	01/06/06	SW-846 8082	2,2',3,4,4',5,5'-Heptachlorobiphenyl	1 D	µg/kg	CONF	72.7	%	J	None	Datum is estimated, bias unknown; %D between primary and secondary GC columns outside acceptance criterion

TABLE 1
DATA QUALIFIERS SUMMARY TABLE
DEMONSTRATION TESTING AND FULL-SCALE OPERATION OF THE BIOGENESIS SEDIMENT DECONTAMINATION PROCESS, KEASBEY, NEW JERSEY
(Page28 of 188)

Location Identification	Sample Identification	Sample Date	Analysis	Analyte	Sample Result	Sample Units	QC Type	QC Result	QC Units	Qualifier	Bias	Comment
WS	WS-060106-1533	01/06/06	SW-846 8082	2,2',3,4,5'-Pentachlorobiphenyl	2 4 D	µg/kg	CONF	107 9	%	J	None	Datum is estimated, bias unknown; %D between primary and secondary GC columns outside acceptance criterion
WS	WS-060106-1533	01/06/06	SW-846 8082	2,2',3,4,5,5'-Hexachlorobiphenyl	0 68 TD	µg/kg	CONF	206 7	%	J	None	Datum is estimated, bias unknown; %D between primary and secondary GC columns outside acceptance criterion
WS	WS-060106-1533	01/06/06	SW-846 8082	2,2',5-Trichlorobiphenyl	6 7 D	µg/kg	CONF	50 5	%	J	None	Datum is estimated, bias unknown; %D between primary and secondary GC columns outside acceptance criterion
WS	WS-060106-1533	01/06/06	SW-846 8082	2,3-Dichlorobiphenyl	0 7 TD	µg/kg	CONF	355 6	%	J	None	Datum is estimated, bias unknown; %D between primary and secondary GC columns outside acceptance criterion
WS	WS-060106-1533	01/06/06	SW-846 8082	2,4,5-Trichlorobiphenyl	6 3 D	µg/kg	CONF	425 2	%	J	None	Datum is estimated, bias unknown; %D between primary and secondary GC columns outside acceptance criterion
WS	WS-060106-1533	01/06/06	SW-846 8082	2-Chlorobiphenyl	3 7 TD	µg/kg	CONF	1000	%	J	None	Datum is estimated, bias unknown; %D between primary and secondary GC columns outside acceptance criterion
WS	WS-060106-1533	01/06/06	SW-846 8290	1,2,3,4,6,7,8-Heptachlorodibenzo-p-dioxin	12 T	pg/g	LB	0 36 T	pg/g	B	None	Analyte detected in associated blank; sample concentration greater than five times the blank concentration
WS	WS-060106-1533	01/06/06	SW-846 8290	1,2,3,4,6,7,8-Heptachlorodibenzofuran	1 8 T	pg/g	IAR LB	1 41 0 29 T	N/A pg/g	JB	None	Datum is estimated, bias unknown; ion abundance ratio outside acceptance criteria Analyte detected in associated blank; sample concentration greater than five times the blank concentration
WS	WS-060106-1533	01/06/06	SW-846 8290	Octachlorodibenzo-p-dioxin	670	pg/g	LB	1 8 T	pg/g	B	None	Analyte detected in associated blank; sample concentration greater than five times the blank concentration
WS	WS-060106-1533	01/06/06	SW-846 8290	Octachlorodibenzofuran	2 2 T	pg/g	LB	0 37 T	pg/g	B	None	Analyte detected in associated blank; sample concentration greater than five times the blank concentration
RS	RS-090106-1500	01/09/06	SW-846 8270 SIM	Pyrene	630	µg/kg	CVS	32 2	%	J	None	Datum is estimated, bias unknown; CVS %D outside acceptance criterion
RS	RS-090106-1500	01/09/06	SW-846 6010B	Zinc	262	mg/kg	MS LB	74 1 0 T	% mg/kg	JB	Low	Datum is estimated, possible low bias; MS recovery outside acceptance criteria Analyte detected in associated blank; sample concentration greater than five times the blank concentration
RS	RS-090106-1500	01/09/06	SW-846 8081A	Beta endosulfan	3 2 T	µg/kg	CONF	59 8	%	J	None	Datum is estimated, bias unknown; %D between primary and secondary GC columns outside acceptance criterion
RS	RS-090106-1500	01/09/06	SW-846 8081A	Dieldrin	2 2 T	µg/kg	CONF	181 3	%	J	None	Datum is estimated, bias unknown; %D between primary and secondary GC columns outside acceptance criterion
RS	RS-090106-1500	01/09/06	SW-846 8081A	p,p'-DDD	3 1 T	µg/kg	CONF	154	%	J	None	Datum is estimated, bias unknown; %D between primary and secondary GC columns outside acceptance criterion
RS	RS-090106-1500	01/09/06	SW-846 8081A	p,p'-DDE	4 6 T	µg/kg	CONF	62	%	J	None	Datum is estimated, bias unknown; %D between primary and secondary GC columns outside acceptance criterion

TABLE 1
DATA QUALIFIERS SUMMARY TABLE
DEMONSTRATION TESTING AND FULL-SCALE OPERATION OF THE BIOGENESIS SEDIMENT DECONTAMINATION PROCESS, KEASBEY, NEW JERSEY
(Page29 of 188)

Location Identification	Sample Identification	Sample Date	Analysis	Analyte	Sample Result	Sample Units	QC Type	QC Result	QC Units	Qualifier	Bias	Comment
RS	RS-090106-1500	01/09/06	SW-846 8082	2,2',3,4,4',5,5'-Heptachlorobiphenyl	0.72	µg/kg	CONF	62.5	%	J	None	Datum is estimated, bias unknown; %D between primary and secondary GC columns outside acceptance criterion
RS	RS-090106-1500	01/09/06	SW-846 8082	2,2',3,4,5'-Pentachlorobiphenyl	1.7	µg/kg	CONF	117.6	%	J	None	Datum is estimated, bias unknown; %D between primary and secondary GC columns outside acceptance criterion
RS	RS-090106-1500	01/09/06	SW-846 8082	2,2',3,4,5,5'-Hexachlorobiphenyl	0.44 T	µg/kg	CONF	327.3	%	J	None	Datum is estimated, bias unknown; %D between primary and secondary GC columns outside acceptance criterion
RS	RS-090106-1500	01/09/06	SW-846 8082	2,2',5-Trichlorobiphenyl	4.3	µg/kg	CONF	62.2	%	J	None	Datum is estimated, bias unknown; %D between primary and secondary GC columns outside acceptance criterion
RS	RS-090106-1500	01/09/06	SW-846 8082	2,3-Dichlorobiphenyl	1.4	µg/kg	CONF	95.7	%	J	None	Datum is estimated, bias unknown; %D between primary and secondary GC columns outside acceptance criterion
RS	RS-090106-1500	01/09/06	SW-846 8082	2,4,5-Trichlorobiphenyl	4.9	µg/kg	CONF	1000	%	J	None	Datum is estimated, bias unknown; %D between primary and secondary GC columns outside acceptance criterion
RS	RS-090106-1500	01/09/06	SW-846 8082	2-Chlorobiphenyl	4 T	µg/kg	CONF	1000	%	J	None	Datum is estimated, bias unknown; %D between primary and secondary GC columns outside acceptance criterion
RS	RS-090106-1500	01/09/06	SW-846 8290	1,2,3,7,8,9-Hexachlorodibenzofuran	1.8 T	pg/g	IAR	0.97	N/A	J	None	Datum is estimated, bias unknown; ion abundance ratio outside acceptance criteria
RS	RS-090106-1500	01/09/06	SW-846 8290	1,2,3,7,8-Pentachlorodibenzo-p-dioxin	2.5 T	pg/g	IAR	0.85	N/A	J	None	Datum is estimated, bias unknown; ion abundance ratio outside acceptance criteria
RS	RS-090106-1500	01/09/06	SW-846 8290	1,2,3,7,8-Pentachlorodibenzofuran	3.2 T	pg/g	IAR	1.04	N/A	J	None	Datum is estimated, bias unknown; ion abundance ratio outside acceptance criteria
RS	RS-090106-1500	01/09/06	SW-846 8290	2,3,4,7,8-Pentachlorodibenzofuran	5.1 T	pg/g	IAR	1.19	N/A	J	None	Datum is estimated, bias unknown; ion abundance ratio outside acceptance criteria
RS	RS-090106-1500	01/09/06	SW-846 8290	2,3,7,8-Tetrachlorodibenzofuran	1.4 T	pg/g	IAR	0.4	N/A	J	None	Datum is estimated, bias unknown; ion abundance ratio outside acceptance criteria
RS	RS-090106-1500	01/09/06	SW-846 8290	Octachlorodibenzo-p-dioxin	9600	pg/g	LB	1.9 T	pg/g	B	None	Analyte detected in associated blank; sample concentration greater than five times the blank concentration
TS	TS-090106-1501	01/09/06	SW-846 8270 SIM	Pyrene	460 D	µg/kg	CVS	32.2	%	J	None	Datum is estimated, bias unknown; CVS %D outside acceptance criterion
TS	TS-090106-1501	01/09/06	SW-846 6010B	Zinc	128	mg/kg	LB	1.0 T	mg/kg	B	None	Analyte detected in associated blank; sample concentration greater than five times the blank concentration
TS	TS-090106-1501	01/09/06	SW-846 8081A	Dieldrin	0.70 T	µg/kg	CONF	94.3	%	J	None	Datum is estimated, bias unknown; %D between primary and secondary GC columns outside acceptance criterion
TS	TS-090106-1501	01/09/06	SW-846 8081A	Gamma-Chlordane	0.39 T	µg/kg	CONF	340.6	%	J	None	Datum is estimated, bias unknown; %D between primary and secondary GC columns outside acceptance criterion

TABLE 1
DATA QUALIFIERS SUMMARY TABLE
DEMONSTRATION TESTING AND FULL-SCALE OPERATION OF THE BIOGENESIS SEDIMENT DECONTAMINATION PROCESS, KEASBEY, NEW JERSEY
(Page30 of 188)

Location Identification	Sample Identification	Sample Date	Analysis	Analyte	Sample Result	Sample Units	QC Type	QC Result	QC Units	Qualifier	Bias	Comment	
TS	TS-090106-1501	01/09/06	SW-846 8081A		p,p'-DDT	8.4	µg/kg	CONF	48	%	J	None	Datum is estimated, bias unknown; %D between primary and secondary GC columns outside acceptance criterion
TS	TS-090106-1501	01/09/06	SW-846 8082		2,2',3,4,5'-Pentachlorobiphenyl	1.5 TD	µg/kg	CONF	141.3	%	J	None	Datum is estimated, bias unknown; %D between primary and secondary GC columns outside acceptance criterion
TS	TS-090106-1501	01/09/06	SW-846 8082		2,2',4,5,5'-Pentachlorobiphenyl	2.5 TD	µg/kg	CONF	59.8	%	J	None	Datum is estimated, bias unknown; %D between primary and secondary GC columns outside acceptance criterion
TS	TS-090106-1501	01/09/06	SW-846 8082		2,2',5-Trichlorobiphenyl	4.3 D	µg/kg	CONF	470.4	%	J	None	Datum is estimated, bias unknown; %D between primary and secondary GC columns outside acceptance criterion
TS	TS-090106-1501	01/09/06	SW-846 8082		2,3-Dichlorobiphenyl	3.6 D	µg/kg	CONF	42.1	%	J	None	Datum is estimated, bias unknown; %D between primary and secondary GC columns outside acceptance criterion
TS	TS-090106-1501	01/09/06	SW-846 8082		2,4,5-Trichlorobiphenyl	4.4 D	µg/kg	CONF	473.8	%	J	None	Datum is estimated, bias unknown; %D between primary and secondary GC columns outside acceptance criterion
TS	TS-090106-1501	01/09/06	SW-846 8082		2-Chlorobiphenyl	7.6 TD	µg/kg	CONF	1000	%	J	None	Datum is estimated, bias unknown; %D between primary and secondary GC columns outside acceptance criterion
TS	TS-090106-1501	01/09/06	SW-846 8290		1,2,3,4,6,7,8-Heptachlorodibenzofuran	1.0 T	pg/g	IAR	1.32	N/A	J	None	Datum is estimated, bias unknown; ion abundance ratio outside acceptance criteria
TS	TS-090106-1501	01/09/06	SW-846 8290		1,2,3,6,7,8-Hexachlorodibenzofuran	0.17 T	pg/g	IAR	1.86	N/A	J	None	Datum is estimated, bias unknown; ion abundance ratio outside acceptance criteria
TS	TS-090106-1501	01/09/06	SW-846 8290		1,2,3,7,8,9-Hexachlorodibenzo-p-Dioxin	0.37 T	pg/g	IAR	0.92	N/A	J	None	Datum is estimated, bias unknown; ion abundance ratio outside acceptance criteria
TS	TS-090106-1501	01/09/06	SW-846 8290		2,3,4,7,8-Pentachlorodibenzofuran	0.42 T	pg/g	IAR	1.09	N/A	J	None	Datum is estimated, bias unknown; ion abundance ratio outside acceptance criteria
TS	TS-090106-1501	01/09/06	SW-846 8290		2,3,7,8-Tetrachlorodibenzofuran	0.92 T	pg/g	IAR	0.98	N/A	J	None	Datum is estimated, bias unknown; ion abundance ratio outside acceptance criteria
TS	TS-090106-1501	01/09/06	SW-846 8290		Octachlorodibenzo-p-dioxin	210	pg/g	LB	0.58 T	pg/g	B	None	Analyte detected in associated blank; sample concentration greater than five times the blank concentration
TS	TS-090106-1501	01/09/06	SW-846 8290		Octachlorodibenzofuran	0.78 T	pg/g	IAR	0.7	N/A	J	None	Datum is estimated, bias unknown; ion abundance ratio outside acceptance criteria
WS	WS-090106-1502	01/09/06	SW-846 8270 SIM		Pyrene	150	µg/kg	CVS	32.2	%	J	None	Datum is estimated, bias unknown; CVS %D outside acceptance criterion
WS	WS-090106-1502	01/09/06	SW-846 6010B		Zinc	326	mg/kg	LB	1.0 T	mg/kg	B	None	Analyte detected in associated blank; sample concentration greater than five times the blank concentration
WS	WS-090106-1502	01/09/06	SW-846 8081A		Alpha-Chlordane	1.7 T	µg/kg	CONF	90.8	%	J	None	Datum is estimated, bias unknown; %D between primary and secondary GC columns outside acceptance criterion

TABLE 1
DATA QUALIFIERS SUMMARY TABLE
DEMONSTRATION TESTING AND FULL-SCALE OPERATION OF THE BIOGENESIS SEDIMENT DECONTAMINATION PROCESS, KEASBEY, NEW JERSEY
(Page31 of 188)

Location Identification	Sample Identification	Sample Date	Analysis	Analyte	Sample Result	Sample Units	QC Type	QC Result	QC Units	Qualifier	Bias	Comment
WS	WS-090106-1502	01/09/06	SW-846 8081A	beta Endosulfan	3.5 T	µg/kg	CONF	49.1	%	J	None	Datum is estimated, bias unknown; %D between primary and secondary GC columns outside acceptance criterion
WS	WS-090106-1502	01/09/06	SW-846 8081A	Dieldrin	1.3 T	µg/kg	CONF	324	%	J	None	Datum is estimated, bias unknown; %D between primary and secondary GC columns outside acceptance criterion
WS	WS-090106-1502	01/09/06	SW-846 8081A	Gamma-Chlordane	0.68 T	µg/kg	CONF	427.2	%	J	None	Datum is estimated, bias unknown; %D between primary and secondary GC columns outside acceptance criterion
WS	WS-090106-1502	01/09/06	SW-846 8081A	p,p'-DDD	3.5 T	µg/kg	CONF	114.7	%	J	None	Datum is estimated, bias unknown; %D between primary and secondary GC columns outside acceptance criterion
WS	WS-090106-1502	01/09/06	SW-846 8081A	p,p'-DDE	3.7 T	µg/kg	CONF	93	%	J	None	Datum is estimated, bias unknown; %D between primary and secondary GC columns outside acceptance criterion
WS	WS-090106-1502	01/09/06	SW-846 8082	2,2',3,4,4',5,5'-Heptachlorobiphenyl	0.69 TD	µg/kg	CONF	63.4	%	J	None	Datum is estimated, bias unknown; %D between primary and secondary GC columns outside acceptance criterion
WS	WS-090106-1502	01/09/06	SW-846 8082	2,2',3,4,5'-Pentachlorobiphenyl	1.9 D	µg/kg	CONF	105.8	%	J	None	Datum is estimated, bias unknown; %D between primary and secondary GC columns outside acceptance criterion
WS	WS-090106-1502	01/09/06	SW-846 8082	2,2',3,4,5,5'-Hexachlorobiphenyl	0.44 TD	µg/kg	CONF	260	%	J	None	Datum is estimated, bias unknown; %D between primary and secondary GC columns outside acceptance criterion
WS	WS-090106-1502	01/09/06	SW-846 8082	2,2',5-Trichlorobiphenyl	5.3 D	µg/kg	CONF	50.7	%	J	None	Datum is estimated, bias unknown; %D between primary and secondary GC columns outside acceptance criterion
WS	WS-090106-1502	01/09/06	SW-846 8082	2,3-Dichlorobiphenyl	0.51 TD	µg/kg	CONF	394.8	%	J	None	Datum is estimated, bias unknown; %D between primary and secondary GC columns outside acceptance criterion
WS	WS-090106-1502	01/09/06	SW-846 8082	2,4,5-Trichlorobiphenyl	5.2 D	µg/kg	CONF	299.4	%	J	None	Datum is estimated, bias unknown; %D between primary and secondary GC columns outside acceptance criterion
WS	WS-090106-1502	01/09/06	SW-846 8082	2-Chlorobiphenyl	3.5 TD	µg/kg	CONF	1000	%	J	None	Datum is estimated, bias unknown; %D between primary and secondary GC columns outside acceptance criterion
WS	WS-090106-1502	01/09/06	SW-846 8290	1,2,3,4,6,7,8-Heptachlorodibenzofuran	4.1 T	pg/g	IAR	1.45	N/A	J	None	Datum is estimated, bias unknown; ion abundance ratio outside acceptance criteria
WS	WS-090106-1502	01/09/06	SW-846 8290	1,2,3,4,7,8-Hexachlorodibenzofuran	0.98 T	pg/g	IAR	1.86	N/A	J	None	Datum is estimated, bias unknown; ion abundance ratio outside acceptance criteria
WS	WS-090106-1502	01/09/06	SW-846 8290	1,2,3,7,8,9-Hexachlorodibenzo-p-Dioxin	1.2 T	pg/g	IAR	0.97	N/A	J	None	Datum is estimated, bias unknown; ion abundance ratio outside acceptance criteria
WS	WS-090106-1502	01/09/06	SW-846 8290	2,3,4,7,8-Pentachlorodibenzofuran	0.56 T	pg/g	IAR	0.99	N/A	J	None	Datum is estimated, bias unknown; ion abundance ratio outside acceptance criteria
WS	WS-090106-1502	01/09/06	SW-846 8290	Octachlorodibenzo-p-dioxin	1600	pg/g	LB	0.58 T	pg/g	B	None	Analyte detected in associated blank; sample concentration greater than five times the blank concentration

TABLE 1
DATA QUALIFIERS SUMMARY TABLE
DEMONSTRATION TESTING AND FULL-SCALE OPERATION OF THE BIOGENESIS SEDIMENT DECONTAMINATION PROCESS, KEASBEY, NEW JERSEY
 (Page32 of 188)

Location Identification	Sample Identification	Sample Date	Analysis	Analyte	Sample Result	Sample Units	QC Type	QC Result	QC Units	Qualifier	Bias	Comment
RS	RS-100106-1600	01/10/06	SW-846 6010B	Barium	218	mg/kg	LB	0 20 T	mg/kg	B	None	Analyte detected in associated blank; sample concentration greater than five times the blank concentration
RS	RS-100106-1600	01/10/06	SW-846 6010B	Zinc	240	mg/kg	LB	0 19 T	mg/kg	B	None	Analyte detected in associated blank; sample concentration greater than five times the blank concentration
RS	RS-100106-1600	01/10/06	SW-846 8081A	Alpha-Chlordane	3 3 TD	µg/kg	CONF	462 3	%	J	None	Datum is estimated, bias unknown; %D between primary and secondary GC columns outside acceptance criterion
RS	RS-100106-1600	01/10/06	SW-846 8081A	Endosulfan sulfate	16 TD	µg/kg	CONF	364 6	%	J	None	Datum is estimated, bias unknown; %D between primary and secondary GC columns outside acceptance criterion
RS	RS-100106-1600	01/10/06	SW-846 8081A	Endrin aldehyde	120 D	µg/kg	CONF	73 7	%	J	None	Datum is estimated, bias unknown; %D between primary and secondary GC columns outside acceptance criterion
RS	RS-100106-1600	01/10/06	SW-846 8081A	p,p'-DDE	7 3 TD	µg/kg	CONF	355	%	J	None	Datum is estimated, bias unknown; %D between primary and secondary GC columns outside acceptance criterion
RS	RS-100106-1600	01/10/06	SW-846 8082	2,2',3,4,5,5'-Pentachlorobiphenyl	3 2 D	µg/kg	CONF	155 4	%	J	None	Datum is estimated, bias unknown; %D between primary and secondary GC columns outside acceptance criterion
RS	RS-100106-1600	01/10/06	SW-846 8082	2,2',3,4,5,5'-Hexachlorobiphenyl	0 94 TD	µg/kg	CONF	321 9	%	J	None	Datum is estimated, bias unknown; %D between primary and secondary GC columns outside acceptance criterion
RS	RS-100106-1600	01/10/06	SW-846 8082	2,2',4,5,5'-Pentachlorobiphenyl	5 3 D	µg/kg	CONF	54 7	%	J	None	Datum is estimated, bias unknown; %D between primary and secondary GC columns outside acceptance criterion
RS	RS-100106-1600	01/10/06	SW-846 8082	2,2',5-Trichlorobiphenyl	9 6 D	µg/kg	CONF	44 5	%	J	None	Datum is estimated, bias unknown; %D between primary and secondary GC columns outside acceptance criterion
RS	RS-100106-1600	01/10/06	SW-846 8082	2,3-Dichlorobiphenyl	3 2 D	µg/kg	CONF	145 3	%	J	None	Datum is estimated, bias unknown; %D between primary and secondary GC columns outside acceptance criterion
RS	RS-100106-1600	01/10/06	SW-846 8082	2,4,5-Trichlorobiphenyl	8 8 D	µg/kg	CONF	497 4	%	J	None	Datum is estimated, bias unknown; %D between primary and secondary GC columns outside acceptance criterion
RS	RS-100106-1600	01/10/06	SW-846 8082	2-Chlorobiphenyl	9 7 TD	µg/kg	CONF	530 6	%	J	None	Datum is estimated, bias unknown; %D between primary and secondary GC columns outside acceptance criterion
RS	RS-100106-1600	01/10/06	SW-846 8290	1,2,3,4,7,8,9-Heptachlorodibenzofuran	3 1 T	pg/g	IAR	0 79	N/A	J	None	Datum is estimated, bias unknown; ion abundance ratio outside acceptance criteria
RS	RS-100106-1600	01/10/06	SW-846 8290	1,2,3,4,7,8-Hexachlorodibenzo-p-dioxin	2 0 T	pg/g	IAR	0 79	N/A	J	None	Datum is estimated, bias unknown; ion abundance ratio outside acceptance criteria
RS	RS-100106-1600	01/10/06	SW-846 8290	2,3,7,8-Tetrachlorodibenzofuran	3 7 T	pg/g	IAR	1 28	N/A	J	None	Datum is estimated, bias unknown; ion abundance ratio outside acceptance criteria

TABLE 1
DATA QUALIFIERS SUMMARY TABLE
DEMONSTRATION TESTING AND FULL-SCALE OPERATION OF THE BIOGENESIS SEDIMENT DECONTAMINATION PROCESS, KEASBEY, NEW JERSEY
 (Page33 of 188)

Location Identification	Sample Identification	Sample Date	Analysis	Analyte	Sample Result	Sample Units	QC Type	QC Result	QC Units	Qualifier	Bias	Comment
RS	RS-100106-1600	01/10/06	SW-846 8290	Octachlorodibenzo-p-dioxin	9300	pg/g	LB	1 9 T	pg/g	B	None	Analyte detected in associated blank; sample concentration greater than five times the blank concentration
TS	TS-100106-1601	01/10/06	SW-846 6010B	Barium	82 5	mg/kg	LB	0 20 T	mg/kg	B	None	Analyte detected in associated blank; sample concentration greater than five times the blank concentration
TS	TS-100106-1601	01/10/06	SW-846 6010B	Zinc	144	mg/kg	LB	0 19 T	mg/kg	B	None	Analyte detected in associated blank; sample concentration greater than five times the blank concentration
TS	TS-100106-1601	01/10/06	SW-846 8081A	Alpha BHC (alpha Hexachlorocyclohexane)	11 TD	µg/kg	CONF	134 6	%	J	None	Datum is estimated, bias unknown; %D between primary and secondary GC columns outside acceptance criterion
TS	TS-100106-1601	01/10/06	SW-846 8081A	beta Endosulfan	<32 D	µg/kg	CONF	795 4	%	J	None	Datum is estimated, bias unknown; %D between primary and secondary GC columns outside acceptance criterion
TS	TS-100106-1601	01/10/06	SW-846 8081A	Endrin	8 8 TD	µg/kg	CONF	48 3	%	J	None	Datum is estimated, bias unknown; %D between primary and secondary GC columns outside acceptance criterion
TS	TS-100106-1601	01/10/06	SW-846 8081A	Heptachlor epoxide	9 7 TD	µg/kg	CONF	173 5	%	J	None	Datum is estimated, bias unknown; %D between primary and secondary GC columns outside acceptance criterion
TS	TS-100106-1601	01/10/06	SW-846 8081A	p,p'-DDD	24 TD	µg/kg	CONF	155 1	%	J	None	Datum is estimated, bias unknown; %D between primary and secondary GC columns outside acceptance criterion
TS	TS-100106-1601	01/10/06	SW-846 8082	2,2',3,4,5'-Pentachlorobiphenyl	9 7 TD	µg/kg	CONF	175 6	%	J	None	Datum is estimated, bias unknown; %D between primary and secondary GC columns outside acceptance criterion
TS	TS-100106-1601	01/10/06	SW-846 8082	2,2',3,4,5,5'-Hexachlorobiphenyl	5 5 TD	µg/kg	CONF	122 7	%	J	None	Datum is estimated, bias unknown; %D between primary and secondary GC columns outside acceptance criterion
TS	TS-100106-1601	01/10/06	SW-846 8082	2,2',4,4',5,5'-Hexachlorobiphenyl	13 TD	µg/kg	CONF	147 6	%	J	None	Datum is estimated, bias unknown; %D between primary and secondary GC columns outside acceptance criterion
TS	TS-100106-1601	01/10/06	SW-846 8082	2,2',4,5,5'-Pentachlorobiphenyl	14 TD	µg/kg	CONF	141 4	%	J	None	Datum is estimated, bias unknown; %D between primary and secondary GC columns outside acceptance criterion
TS	TS-100106-1601	01/10/06	SW-846 8082	2,2',5,5'-Tetrachlorobiphenyl	24 TD	µg/kg	CONF	197	%	J	None	Datum is estimated, bias unknown; %D between primary and secondary GC columns outside acceptance criterion
TS	TS-100106-1601	01/10/06	SW-846 8082	2,2',5-Trichlorobiphenyl	38 D	µg/kg	CONF	160 4	%	J	None	Datum is estimated, bias unknown; %D between primary and secondary GC columns outside acceptance criterion
TS	TS-100106-1601	01/10/06	SW-846 8082	2,3',4,4'-Tetrachlorobiphenyl	40 D	µg/kg	CONF	56 4	%	J	None	Datum is estimated, bias unknown; %D between primary and secondary GC columns outside acceptance criterion
TS	TS-100106-1601	01/10/06	SW-846 8082	2,3-Dichlorobiphenyl	77 D	µg/kg	CONF	791 8	%	J	None	Datum is estimated, bias unknown; %D between primary and secondary GC columns outside acceptance criterion

TABLE 1
DATA QUALIFIERS SUMMARY TABLE
DEMONSTRATION TESTING AND FULL-SCALE OPERATION OF THE BIOGENESIS SEDIMENT DECONTAMINATION PROCESS, KEASBEY, NEW JERSEY
(Page34 of 188)

Location Identification	Sample Identification	Sample Date	Analysis	Analyte	Sample Result	Sample Units	QC Type	QC Result	QC Units	Qualifier	Bias	Comment
TS	TS-100106-1601	01/10/06	SW-846 8082	2-Chlorobiphenyl	150 TD	µg/kg	CONF	580	%	J	None	Datum is estimated, bias unknown; %D between primary and secondary GC columns outside acceptance criterion
TS	TS-100106-1601	01/10/06	SW-846 8290	1,2,3,4,6,7,8-Heptachlorodibenzo-p-dioxin	53	pg/g	MSD	160	%	J	High	Datum is estimated, possible high bias; MSD recovery outside acceptance criteria
TS	TS-100106-1601	01/10/06	SW-846 8290	1,2,3,4,7,8,9-Heptachlorodibenzofuran	4.1 T	pg/g	IAR	1.22	N/A	J	None	Datum is estimated, bias unknown; ion abundance ratio outside acceptance criteria
TS	TS-100106-1601	01/10/06	SW-846 8290	1,2,3,7,8,9-Hexachlorodibenzofuran	0.38 T	pg/g	MS MSD	49 48	%	J	Low	Datum is estimated, possible low bias; MS/MSD recoveries outside acceptance criteria
TS	TS-100106-1601	01/10/06	SW-846 8290	1,2,3,7,8-Pentachlorodibenzo-p-dioxin	1.3 T	pg/g	IAR	1.18	N/A	J	None	Datum is estimated, bias unknown; ion abundance ratio outside acceptance criteria
TS	TS-100106-1601	01/10/06	SW-846 8290	1,2,3,7,8-Pentachlorodibenzofuran	2.3 T	pg/g	IAR	1.89	N/A	J	None	Datum is estimated, bias unknown; ion abundance ratio outside acceptance criteria
TS	TS-100106-1601	01/10/06	SW-846 8290	2,3,7,8-Tetrachlorodibenzofuran	4.4	pg/g	MS MSD IAR	46 61 1.05	% % N/A	J	Low	Datum is estimated, possible low bias; MS/MSD recoveries and ion abundance ratio outside acceptance criteria
TS	TS-100106-1601	01/10/06	SW-846 8290	Octachlorodibenzo-p-dioxin	820	pg/g	MS MSD LB	180 388 1.9 T	% % pg/g	JB	High	Datum is estimated, possible high bias; MS/MSD recoveries outside acceptance criteria. Analyte detected in associated blank; sample concentration greater than five times blank concentration
WS	WS-100106-1602	01/10/06	SW-846 6010B	Barium	116	mg/kg	LB	0.20 T	mg/kg	B	None	Analyte detected in associated blank; sample concentration greater than five times the blank concentration
WS	WS-100106-1602	01/10/06	SW-846 6010B	Zinc	246	mg/kg	LB	0.19 T	mg/kg	B	None	Analyte detected in associated blank; sample concentration greater than five times the blank concentration
WS	WS-100106-1602	01/10/06	SW-846 8082	2,2',3,4,4',5,5'-Heptachlorobiphenyl	0.73	µg/kg	CONF	52.2	%	J	None	Datum is estimated, bias unknown; %D between primary and secondary GC columns outside acceptance criterion
WS	WS-100106-1602	01/10/06	SW-846 8082	2,2',3,4,5'-Pentachlorobiphenyl	1.8	µg/kg	CONF	139.6	%	J	None	Datum is estimated, bias unknown; %D between primary and secondary GC columns outside acceptance criterion
WS	WS-100106-1602	01/10/06	SW-846 8082	2,2',3,4,5,5'-Hexachlorobiphenyl	0.53	µg/kg	CONF	252.5	%	J	None	Datum is estimated, bias unknown; %D between primary and secondary GC columns outside acceptance criterion
WS	WS-100106-1602	01/10/06	SW-846 8082	2,2',5-Trichlorobiphenyl	5.6	µg/kg	CONF	43.8	%	J	None	Datum is estimated, bias unknown; %D between primary and secondary GC columns outside acceptance criterion
WS	WS-100106-1602	01/10/06	SW-846 8082	2,3-Dichlorobiphenyl	1.1	µg/kg	CONF	175.6	%	J	None	Datum is estimated, bias unknown; %D between primary and secondary GC columns outside acceptance criterion
WS	WS-100106-1602	01/10/06	SW-846 8082	2,4,5-Trichlorobiphenyl	5.2	µg/kg	CONF	283.2	%	J	None	Datum is estimated, bias unknown; %D between primary and secondary GC columns outside acceptance criterion

TABLE 1
DATA QUALIFIERS SUMMARY TABLE
DEMONSTRATION TESTING AND FULL-SCALE OPERATION OF THE BIOGENESIS SEDIMENT DECONTAMINATION PROCESS, KEASBEY, NEW JERSEY
(Page35 of 188)

Location Identification	Sample Identification	Sample Date	Analysis	Analyte	Sample Result	Sample Units	QC Type	QC Result	QC Units	Qualifier	Bias	Comment
WS	WS-100106-1602	01/10/06	SW-846 8082	2-Chlorobiphenyl	3.9 T	µg/kg	CONF	955.1	%	J	None	Datum is estimated, bias unknown; %D between primary and secondary GC columns outside acceptance criterion
WS	WS-100106-1602	01/10/06	SW-846 8290	1,2,3,6,7,8-Hexachlorodibenzo-p-Dioxin	0.62 T	pg/g	IAR	1.48	N/A	J	None	Datum is estimated, bias unknown; ion abundance ratio outside acceptance criteria
WS	WS-100106-1602	01/10/06	SW-846 8290	1,2,3,7,8-Pentachlorodibenzofuran	0.22 T	pg/g	IAR	0.69	N/A	J	None	Datum is estimated, bias unknown; ion abundance ratio outside acceptance criteria
WS	WS-100106-1602	01/10/06	SW-846 8290	2,3,7,8-Tetrachlorodibenzofuran	1.1 T	pg/g	IAR	1.66	N/A	J	None	Datum is estimated, bias unknown; ion abundance ratio outside acceptance criteria
WS	WS-100106-1602	01/10/06	SW-846 8290	Octachlorodibenzo-p-dioxin	910	pg/g	LB	1.9 T	pg/g	B	None	Analyte detected in associated blank; sample concentration greater than five times the blank concentration
WS	WS-100106-1602	01/10/06	SW-846 8082	2,2',4,5,5'-Pentachlorobiphenyl	2.8	µg/kg	MS MSD CONF	11 44 55.8	%	J	Low	Datum is estimated, possible low bias; MS/MSD recoveries and %D between primary and secondary GC columns outside acceptance criteria
WS	WS-100106-1602	01/10/06	SW-846 8082	2,2',5,5'-Tetrachlorobiphenyl	10	µg/kg	MS MSD	0 0	%	J	Low	Datum is estimated possible low bias; MS/MSD recoveries outside acceptance criteria
WS	WS-100106-1602	01/10/06	SW-846 8082	2,3',4,4'-Tetrachlorobiphenyl	9	µg/kg	MS MSD	0 0	%	J	Low	Datum is estimated possible low bias; MS/MSD recoveries outside acceptance criteria
RS	RS-110106-1630	01/11/06	SW-846 6010B	Barium	89	mg/kg	LB	0.10 T	mg/kg	B	None	Analyte detected in associated blank; sample concentration greater than five times the blank concentration
RS	RS-110106-1630	01/11/06	SW-846 6010B	Zinc	166	mg/kg	LB	0.38 T	mg/kg	B	None	Analyte detected in associated blank; sample concentration greater than five times the blank concentration
RS	RS-110106-1630	01/11/06	SW-846 8081A	Aldrin	0.78 T	µg/kg	CONF	131.7	%	J	None	Datum is estimated, bias unknown; %D between primary and secondary GC columns outside acceptance criterion
RS	RS-110106-1630	01/11/06	SW-846 8081A	Alpha BHC (alpha Hexachlorocyclohexane)	0.86 T	µg/kg	CONF	42.7	%	J	None	Datum is estimated, bias unknown; %D between primary and secondary GC columns outside acceptance criterion
RS	RS-110106-1630	01/11/06	SW-846 8081A	Alpha-Chlordane	1.7 T	µg/kg	CONF	77.4	%	J	None	Datum is estimated, bias unknown; %D between primary and secondary GC columns outside acceptance criterion
RS	RS-110106-1630	01/11/06	SW-846 8081A	Chlordane	15 T	µg/kg	CONF	51.9	%	J	None	Datum is estimated, bias unknown; %D between primary and secondary GC columns outside acceptance criterion
RS	RS-110106-1630	01/11/06	SW-846 8081A	p,p'-DDD	2.3 T	µg/kg	CONF	46.7	%	J	None	Datum is estimated, bias unknown; %D between primary and secondary GC columns outside acceptance criterion
RS	RS-110106-1630	01/11/06	SW-846 8081A	p,p'-DDE	2.9 T	µg/kg	CONF	77.3	%	J	None	Datum is estimated, bias unknown; %D between primary and secondary GC columns outside acceptance criterion
RS	RS-110106-1630	01/11/06	SW-846 8082	2,2',3,4,4',5,5'-Heptachlorobiphenyl	1.1	µg/kg	CONF	78.9	%	J	None	Datum is estimated, bias unknown; %D between primary and secondary GC columns outside acceptance criterion

TABLE 1
DATA QUALIFIERS SUMMARY TABLE
DEMONSTRATION TESTING AND FULL-SCALE OPERATION OF THE BIOGENESIS SEDIMENT DECONTAMINATION PROCESS, KEASBEY, NEW JERSEY
(Page36 of 188)

Location Identification	Sample Identification	Sample Date	Analysis	Analyte	Sample Result	Sample Units	QC Type	QC Result	QC Units	Qualifier	Bias	Comment
RS	RS-110106-1630	01/11/06	SW-846 8082	2,2',3,4,5'-Pentachlorobiphenyl	3 1	µg/kg	CONF	132 6	%	J	None	Datum is estimated, bias unknown; %D between primary and secondary GC columns outside acceptance criterion
RS	RS-110106-1630	01/11/06	SW-846 8082	2,2',3,4,5,5'-Hexachlorobiphenyl	0 92	µg/kg	CONF	245 8	%	J	None	Datum is estimated, bias unknown; %D between primary and secondary GC columns outside acceptance criterion
RS	RS-110106-1630	01/11/06	SW-846 8082	2,2',4,5,5'-Pentachlorobiphenyl	4 6	µg/kg	CONF	55 2	%	J	None	Datum is estimated, bias unknown; %D between primary and secondary GC columns outside acceptance criterion
RS	RS-110106-1630	01/11/06	SW-846 8082	2,2',5-Trichlorobiphenyl	7 7	µg/kg	CONF	71 6	%	J	None	Datum is estimated, bias unknown; %D between primary and secondary GC columns outside acceptance criterion
RS	RS-110106-1630	01/11/06	SW-846 8082	2,3-Dichlorobiphenyl	2 2	µg/kg	CONF	112 8	%	J	None	Datum is estimated, bias unknown; %D between primary and secondary GC columns outside acceptance criterion
RS	RS-110106-1630	01/11/06	SW-846 8082	2,4,5-Trichlorobiphenyl	7 8	µg/kg	CONF	1000	%	J	None	Datum is estimated, bias unknown; %D between primary and secondary GC columns outside acceptance criterion
RS	RS-110106-1630	01/11/06	SW-846 8082	2-Chlorobiphenyl	6 8	µg/kg	CONF	463 6	%	J	None	Datum is estimated, bias unknown; %D between primary and secondary GC columns outside acceptance criterion
RS	RS-110106-1630	01/11/06	SW-846 8290	1,2,3,4,6,7,8-Heptachlorodibenzo-p-dioxin	150	pg/g	LB	0 23 T	pg/g	B	None	Analyte detected in associated blank; sample concentration greater than five times the blank concentration
RS	RS-110106-1630	01/11/06	SW-846 8290	1,2,3,4,6,7,8-Heptachlorodibenzofuran	20	pg/g	LB	0 18 T	pg/g	B	None	Analyte detected in associated blank; sample concentration greater than five times the blank concentration
RS	RS-110106-1630	01/11/06	SW-846 8290	1,2,3,4,7,8,9-Heptachlorodibenzofuran	2 7 T	pg/g	IAR	0 85	N/A	J	None	Datum is estimated, bias unknown; ion abundance ratio outside acceptance criteria
RS	RS-110106-1630	01/11/06	SW-846 8290	1,2,3,6,7,8-Hexachlorodibenzofuran	2 0 T	pg/g	IAR	1 48	N/A	J	None	Datum is estimated, bias unknown; ion abundance ratio outside acceptance criteria
RS	RS-110106-1630	01/11/06	SW-846 8290	1,2,3,7,8-Pentachlorodibenzo-p-dioxin	1 2 T	pg/g	IAR	1 3	N/A	J	None	Datum is estimated, bias unknown; ion abundance ratio outside acceptance criteria
RS	RS-110106-1630	01/11/06	SW-846 8290	2,3,7,8-Tetrachlorodibenzofuran	1 6 T	pg/g	IAR	1 03	N/A	J	None	Datum is estimated, bias unknown; ion abundance ratio outside acceptance criteria
RS	RS-110106-1630	01/11/06	SW-846 8290	Octachlorodibenzo-p-dioxin	8200	pg/g	LB	0 69 T	pg/g	B	None	Analyte detected in associated blank; sample concentration greater than five times the blank concentration
RS	RS-110106-1630	01/11/06	SW-846 8290	Octachlorodibenzofuran	37	pg/g	LB	0 40 T	pg/g	B	None	Analyte detected in associated blank; sample concentration greater than five times the blank concentration
TS	TS-110106-1631	01/11/06	SW-846 6010B	Barium	88 4	mg/kg	LB	0 10 T	mg/kg	B	None	Analyte detected in associated blank; sample concentration greater than five times the blank concentration

TABLE 1
DATA QUALIFIERS SUMMARY TABLE
DEMONSTRATION TESTING AND FULL-SCALE OPERATION OF THE BIOGENESIS SEDIMENT DECONTAMINATION PROCESS, KEASBEY, NEW JERSEY
(Page37 of 188)

Location Identification	Sample Identification	Sample Date	Analysis	Analyte	Sample Result	Sample Units	QC Type	QC Result	QC Units	Qualifier	Bias	Comment
TS	TS-110106-1631	01/11/06	SW-846 6010B	Zinc	192	mg/kg	LB	0 38 T	mg/kg	B	None	Analyte detected in associated blank; sample concentration greater than five times the blank concentration
TS	TS-110106-1631	01/11/06	SW-846 8081A	Alpha BHC (alpha Hexachlorocyclohexane)	4 1	µg/kg	CONF	116 9	%	J	None	Datum is estimated, bias unknown; %D between primary and secondary GC columns outside acceptance criterion
TS	TS-110106-1631	01/11/06	SW-846 8081A	alpha Endosulfan	0 54 T	µg/kg	CONF	1000	%	J	None	Datum is estimated, bias unknown; %D between primary and secondary GC columns outside acceptance criterion
TS	TS-110106-1631	01/11/06	SW-846 8081A	Endosulfan sulfate	3 0 T	µg/kg	CONF	338 4	%	J	None	Datum is estimated, bias unknown; %D between primary and secondary GC columns outside acceptance criterion
TS	TS-110106-1631	01/11/06	SW-846 8081A	Gamma-Chlordane	0 74 T	µg/kg	CONF	1000	%	J	None	Datum is estimated, bias unknown; %D between primary and secondary GC columns outside acceptance criterion
TS	TS-110106-1631	01/11/06	SW-846 8081A	Heptachlor epoxide	3 7	µg/kg	CONF	177 2	%	J	None	Datum is estimated, bias unknown; %D between primary and secondary GC columns outside acceptance criterion
TS	TS-110106-1631	01/11/06	SW-846 8081A	p,p'-DDD	6 4	µg/kg	CONF	86 1	%	J	None	Datum is estimated, bias unknown; %D between primary and secondary GC columns outside acceptance criterion
TS	TS-110106-1631	01/11/06	SW-846 8081A	p,p'-DDE	9 8	µg/kg	CONF	56 8	%	J	None	Datum is estimated, bias unknown; %D between primary and secondary GC columns outside acceptance criterion
TS	TS-110106-1631	01/11/06	SW-846 8082	2,2',3,4',5,5',6-Heptachlorobiphenyl	1 3 TD	µg/kg	CONF	170 8	%	J	None	Datum is estimated, bias unknown; %D between primary and secondary GC columns outside acceptance criterion
TS	TS-110106-1631	01/11/06	SW-846 8082	2,2',3,4,4',5,5'-Heptachlorobiphenyl	3 8 D	µg/kg	CONF	60	%	J	None	Datum is estimated, bias unknown; %D between primary and secondary GC columns outside acceptance criterion
TS	TS-110106-1631	01/11/06	SW-846 8082	2,2',3,4,5'-Pentachlorobiphenyl	4 9 D	µg/kg	CONF	121 2	%	J	None	Datum is estimated, bias unknown; %D between primary and secondary GC columns outside acceptance criterion
TS	TS-110106-1631	01/11/06	SW-846 8082	2,2',3,4,5,5'-Hexachlorobiphenyl	2 4 TD	µg/kg	CONF	167 4	%	J	None	Datum is estimated, bias unknown; %D between primary and secondary GC columns outside acceptance criterion
TS	TS-110106-1631	01/11/06	SW-846 8082	2,2',4,4',5,5'-Hexachlorobiphenyl	9 7 D	µg/kg	CONF	77 1	%	J	None	Datum is estimated, bias unknown; %D between primary and secondary GC columns outside acceptance criterion
TS	TS-110106-1631	01/11/06	SW-846 8082	2,2',4,5,5'-Pentachlorobiphenyl	9 8 D	µg/kg	CONF	47 6	%	J	None	Datum is estimated, bias unknown; %D between primary and secondary GC columns outside acceptance criterion
TS	TS-110106-1631	01/11/06	SW-846 8082	2,2',5,5'-Tetrachlorobiphenyl	26 D	µg/kg	CONF	45 3	%	J	None	Datum is estimated, bias unknown; %D between primary and secondary GC columns outside acceptance criterion
TS	TS-110106-1631	01/11/06	SW-846 8082	2,2',5-Trichlorobiphenyl	20 D	µg/kg	CONF	719 8	%	J	None	Datum is estimated, bias unknown; %D between primary and secondary GC columns outside acceptance criterion
TS	TS-110106-1631	01/11/06	SW-846 8082	2,4,5-Trichlorobiphenyl	18 D	µg/kg	CONF	186 8	%	J	None	Datum is estimated, bias unknown; %D between primary and secondary GC columns outside acceptance criterion

TABLE 1
DATA QUALIFIERS SUMMARY TABLE
DEMONSTRATION TESTING AND FULL-SCALE OPERATION OF THE BIOGENESIS SEDIMENT DECONTAMINATION PROCESS, KEASBEY, NEW JERSEY
(Page38 of 188)

Location Identification	Sample Identification	Sample Date	Analysis	Analyte	Sample Result	Sample Units	QC Type	QC Result	QC Units	Qualifier	Bias	Comment
TS	TS-110106-1631	01/11/06	SW-846 8082	2-Chlorobiphenyl	87 D	µg/kg	CONF	690 5	%	J	None	Datum is estimated, bias unknown; %D between primary and secondary GC columns outside acceptance criterion
TS	TS-110106-1631	01/11/06	SW-846 8290	1,2,3,4,6,7,8-Heptachlorodibenzo-p-dioxin	30	pg/g	LB	0 23 T	pg/g	B	None	Analyte detected in associated blank; sample concentration greater than five times the blank concentration
TS	TS-110106-1631	01/11/06	SW-846 8290	1,2,3,4,6,7,8-Heptachlorodibenzofuran	6 5 T	pg/g	LB	0 18 T	pg/g	B	None	Analyte detected in associated blank; sample concentration greater than five times the blank concentration
TS	TS-110106-1631	01/11/06	SW-846 8290	1,2,3,7,8-Pentachlorodibenzofuran	0 67 T	pg/g	IAR	2 02	N/A	J	None	Datum is estimated, bias unknown; ion abundance ratio outside acceptance criteria
TS	TS-110106-1631	01/11/06	SW-846 8290	2,3,4,7,8-Pentachlorodibenzofuran	1 0 T	pg/g	IAR	1 18	N/A	J	None	Datum is estimated, bias unknown; ion abundance ratio outside acceptance criteria
TS	TS-110106-1631	01/11/06	SW-846 8290	2,3,7,8-Tetrachlorodibenzo-p-dioxin	0 48 T	pg/g	IAR	0 94	N/A	J	None	Datum is estimated, bias unknown; ion abundance ratio outside acceptance criteria
TS	TS-110106-1631	01/11/06	SW-846 8290	2,3,7,8-Tetrachlorodibenzofuran	0 49 T	pg/g	IAR	0 58	N/A	J	None	Datum is estimated, bias unknown; ion abundance ratio outside acceptance criteria
TS	TS-110106-1631	01/11/06	SW-846 8290	Octachlorodibenzo-p-dioxin	1300	pg/g	LB	0 69 T	pg/g	B	None	Analyte detected in associated blank; sample concentration greater than five times the blank concentration
TS	TS-110106-1631	01/11/06	SW-846 8290	Octachlorodibenzofuran	7 4 T	pg/g	LB	0 40 T	pg/g	B	None	Analyte detected in associated blank; sample concentration greater than five times the blank concentration
RS	RS-120106-1630	01/12/06	SW-846 8270 SIM	Pyrene	610	µg/kg	CVS	32 8	%	J	None	Datum is estimated, bias unknown; CVS %D outside acceptance criterion
RS	RS-120106-1630	01/12/06	SW-846 6010B	Barium	137 J	mg/kg	LB	0 17 T	mg/kg	B	None	Analyte detected in associated blank; sample concentration greater than five times the blank concentration
RS	RS-120106-1630	01/12/06	SW-846 6010B	Zinc	281 J	mg/kg	MSD SLD LB	71 11 7 0 36 T	% % mg/kg	JB	Low	Datum is estimated, possible low bias; MSD recovery and serial dilution percent difference outside acceptance criteria Analyte detected in associated blank Sample concentration greater than five times the blank concentration
RS	RS-120106-1630	01/12/06	SW-846 8081A	p,p'-DDD	0 67 T	µg/kg	CONF	52 2	%	J	None	Datum is estimated, bias unknown; %D between primary and secondary GC columns outside acceptance criterion
RS	RS-120106-1630	01/12/06	SW-846 8082	2,2',3,3',4,4',5,5',6-Nonachlorobiphenyl	0 14 T	µg/kg	CONF	157	%	J	None	Datum is estimated, bias unknown; %D between primary and secondary GC columns outside acceptance criterion
RS	RS-120106-1630	01/12/06	SW-846 8082	2,2',3,4,4',5,5'-Heptachlorobiphenyl	0 36 T	µg/kg	CONF	79 5	%	J	None	Datum is estimated, bias unknown; %D between primary and secondary GC columns outside acceptance criterion

TABLE 1
DATA QUALIFIERS SUMMARY TABLE
DEMONSTRATION TESTING AND FULL-SCALE OPERATION OF THE BIOGENESIS SEDIMENT DECONTAMINATION PROCESS, KEASBEY, NEW JERSEY
(Page39 of 188)

Location Identification	Sample Identification	Sample Date	Analysis	Analyte	Sample Result	Sample Units	QC Type	QC Result	QC Units	Qualifier	Bias	Comment
RS	RS-120106-1630	01/12/06	SW-846 8082	2,2',3,4,5'-Pentachlorobiphenyl	0 96	µg/kg	CONF	94 2	%	J	None	Datum is estimated, bias unknown; %D between primary and secondary GC columns outside acceptance criterion
RS	RS-120106-1630	01/12/06	SW-846 8082	2,2',3,4,5,5'-Hexachlorobiphenyl	0 17 T	µg/kg	CONF	399 6	%	J	None	Datum is estimated, bias unknown; %D between primary and secondary GC columns outside acceptance criterion
RS	RS-120106-1630	01/12/06	SW-846 8082	2,2',5-Trichlorobiphenyl	2 7	µg/kg	CONF	70 6	%	J	None	Datum is estimated, bias unknown; %D between primary and secondary GC columns outside acceptance criterion
RS	RS-120106-1630	01/12/06	SW-846 8082	2,3-Dichlorobiphenyl	0 63	µg/kg	CONF	157 9	%	J	None	Datum is estimated, bias unknown; %D between primary and secondary GC columns outside acceptance criterion
RS	RS-120106-1630	01/12/06	SW-846 8082	2,4,5-Trichlorobiphenyl	2 7	µg/kg	CONF	1000	%	J	None	Datum is estimated, bias unknown; %D between primary and secondary GC columns outside acceptance criterion
RS	RS-120106-1630	01/12/06	SW-846 8082	2-Chlorobiphenyl	2 9 T	µg/kg	CONF	1000	%	J	None	Datum is estimated, bias unknown; %D between primary and secondary GC columns outside acceptance criterion
RS	RS-120106-1630	01/12/06	SW-846 8290	1,2,3,4,7,8-Hexachlorodibenzo-p-dioxin	2 2 T	pg/g	IAR	0 96	N/A	J	None	Datum is estimated, bias unknown; ion abundance ratio outside acceptance criteria
RS	RS-120106-1630	01/12/06	SW-846 8290	1,2,3,6,7,8-Hexachlorodibenzofuran	2 4 T	pg/g	IAR	1 68	N/A	J	None	Datum is estimated, bias unknown; ion abundance ratio outside acceptance criteria
RS	RS-120106-1630	01/12/06	SW-846 8290	2,3,7,8-Tetrachlorodibenzo-p-dioxin	1 9 T	pg/g	IAR	1 11	N/A	J	None	Datum is estimated, bias unknown; ion abundance ratio outside acceptance criteria
RS	RS-120106-1630	01/12/06	SW-846 8290	Octachlorodibenzo-p-dioxin	10000 B	pg/g	LB	0 42 T	pg/g	B	None	Analyte detected in associated blank; sample concentration greater than five times the blank concentration
RS	RS-120106-1630	01/12/06	SW-846 8290	Octachlorodibenzofuran	43 T	pg/g	LB	0 26 T	pg/g	B	None	Analyte detected in associated blank; sample concentration greater than five times the blank concentration
TS	TS-120106-1601	01/12/06	SW-846 8270 SIM	Pyrene	2800 D	µg/kg	CVS	32 8	%	J	None	Datum is estimated, bias unknown; CVS %D outside acceptance criterion
TS	TS-120106-1601	01/12/06	SW-846 6010B	Barium	79 9 J	mg/kg	LB	0 17 T	mg/kg	B	None	Analyte detected in associated blank; sample concentration greater than five times the blank concentration
TS	TS-120106-1601	01/12/06	SW-846 6010B	Zinc	151 J	mg/kg	LB	0 36 T	mg/kg	B	None	Analyte detected in associated blank; sample concentration greater than five times the blank concentration
TS	TS-120106-1601	01/12/06	SW-846 8081A	Dieldrin	3 2	µg/kg	CONF	57 2	%	J	None	Datum is estimated, bias unknown; %D between primary and secondary GC columns outside acceptance criterion
TS	TS-120106-1601	01/12/06	SW-846 8081A	Endrin aldehyde	5 3	µg/kg	CONF	532	%	J	None	Datum is estimated, bias unknown; %D between primary and secondary GC columns outside acceptance criterion

TABLE 1
DATA QUALIFIERS SUMMARY TABLE
DEMONSTRATION TESTING AND FULL-SCALE OPERATION OF THE BIOGENESIS SEDIMENT DECONTAMINATION PROCESS, KEASBEY, NEW JERSEY
(Page 40 of 188)

Location Identification	Sample Identification	Sample Date	Analysis	Analyte	Sample Result	Sample Units	QC Type	QC Result	QC Units	Qualifier	Bias	Comment
TS	TS-120106-1601	01/12/06	SW-846 8081A	Endrin ketone	1.7 T	µg/kg	CONF	67	%	J	None	Datum is estimated, bias unknown; %D between primary and secondary GC columns outside acceptance criterion
TS	TS-120106-1601	01/12/06	SW-846 8081A	Gamma-Chlordane	1.7 T	µg/kg	CONF	345.5	%	J	None	Datum is estimated, bias unknown; %D between primary and secondary GC columns outside acceptance criterion
TS	TS-120106-1601	01/12/06	SW-846 8081A	Heptachlor epoxide	2.5 T	µg/kg	CONF	51.3	%	J	None	Datum is estimated, bias unknown; %D between primary and secondary GC columns outside acceptance criterion
TS	TS-120106-1601	01/12/06	SW-846 8081A	Methoxychlor	4.0 T	µg/kg	CONF	123.8	%	J	None	Datum is estimated, bias unknown; %D between primary and secondary GC columns outside acceptance criterion
TS	TS-120106-1601	01/12/06	SW-846 8081A	p,p'-DDT	7.5	µg/kg	CONF	52.2	%	J	None	Datum is estimated, bias unknown; %D between primary and secondary GC columns outside acceptance criterion
TS	TS-120106-1601	01/12/06	SW-846 8082	2,2',3,4,5'-Pentachlorobiphenyl	4.2 D	µg/kg	CONF	259.1	%	J	None	Datum is estimated, bias unknown; %D between primary and secondary GC columns outside acceptance criterion
TS	TS-120106-1601	01/12/06	SW-846 8082	2,2',3,4,5,5'-Hexachlorobiphenyl	1 TD	µg/kg	CONF	348.9	%	J	None	Datum is estimated, bias unknown; %D between primary and secondary GC columns outside acceptance criterion
TS	TS-120106-1601	01/12/06	SW-846 8082	2,2',5-Trichlorobiphenyl	12 D	µg/kg	CONF	273	%	J	None	Datum is estimated, bias unknown; %D between primary and secondary GC columns outside acceptance criterion
TS	TS-120106-1601	01/12/06	SW-846 8082	2,3-Dichlorobiphenyl	4.7 D	µg/kg	CONF	130.5	%	J	None	Datum is estimated, bias unknown; %D between primary and secondary GC columns outside acceptance criterion
TS	TS-120106-1601	01/12/06	SW-846 8082	2,4,5-Trichlorobiphenyl	12 D	µg/kg	CONF	114.9	%	J	None	Datum is estimated, bias unknown; %D between primary and secondary GC columns outside acceptance criterion
TS	TS-120106-1601	01/12/06	SW-846 8082	2-Chlorobiphenyl	13 TD	µg/kg	CONF	759.3	%	J	None	Datum is estimated, bias unknown; %D between primary and secondary GC columns outside acceptance criterion
TS	TS-120106-1601	01/12/06	SW-846 8290	1,2,3,6,7,8-Hexachlorodibenzofuran	1.5 T	pg/g	IAR	1.45	N/A	J	None	Datum is estimated, bias unknown; ion abundance ratio outside acceptance criteria
TS	TS-120106-1601	01/12/06	SW-846 8290	1,2,3,7,8-Pentachlorodibenzo-p-dioxin	1.1 T	pg/g	IAR	1.27	N/A	J	None	Datum is estimated, bias unknown; ion abundance ratio outside acceptance criteria
TS	TS-120106-1601	01/12/06	SW-846 8290	2,3,7,8-Tetrachlorodibenzofuran	5.1	pg/g	IAR	0.94	N/A	J	None	Datum is estimated, bias unknown; ion abundance ratio outside acceptance criteria
TS	TS-120106-1601	01/12/06	SW-846 8290	Octachlorodibenzo-p-dioxin	2200 B	pg/g	LB	0.42 T	pg/g	B	None	Analyte detected in associated blank; sample concentration greater than five times the blank concentration
TS	TS-120106-1601	01/12/06	SW-846 8290	Octachlorodibenzofuran	23 B	pg/g	LB	0.26 T	pg/g	B	None	Analyte detected in associated blank; sample concentration greater than five times the blank concentration
WS	WS-120106-1602	01/12/06	SW-846 8270 SIM	Pyrene	370	µg/kg	CVS	32.8	%	J	None	Datum is estimated, bias unknown; CVS %D outside acceptance criterion

TABLE 1
DATA QUALIFIERS SUMMARY TABLE
DEMONSTRATION TESTING AND FULL-SCALE OPERATION OF THE BIOGENESIS SEDIMENT DECONTAMINATION PROCESS, KEASBEY, NEW JERSEY
(Page 41 of 188)

Location Identification	Sample Identification	Sample Date	Analysis	Analyte	Sample Result	Sample Units	QC Type	QC Result	QC Units	Qualifier	Bias	Comment
WS	WS-120106-1602	01/12/06	SW-846 6010B	Barium	126 J	mg/kg	LB	0 17 T	mg/kg	B	None	Analyte detected in associated blank; sample concentration greater than five times the blank concentration
WS	WS-120106-1602	01/12/06	SW-846 6010B	Zinc	298 J	mg/kg	LB	0 36 T	mg/kg	B	None	Analyte detected in associated blank; sample concentration greater than five times the blank concentration
WS	WS-120106-1602	01/12/06	SW-846 8081A	Aldrin	0 67 T	µg/kg	CONF	276 8	%	J	None	Datum is estimated, bias unknown; %D between primary and secondary GC columns outside acceptance criterion
WS	WS-120106-1602	01/12/06	SW-846 8081A	Alpha-Chlordane	2 1 T	µg/kg	CONF	166 8	%	J	None	Datum is estimated, bias unknown; %D between primary and secondary GC columns outside acceptance criterion
WS	WS-120106-1602	01/12/06	SW-846 8081A	Endosulfan sulfate	0 88 T	µg/kg	CONF	120 2	%	J	None	Datum is estimated, bias unknown; %D between primary and secondary GC columns outside acceptance criterion
WS	WS-120106-1602	01/12/06	SW-846 8081A	Gamma BHC (lindane)	0 48 T	µg/kg	CONF	57 2	%	J	None	Datum is estimated, bias unknown; %D between primary and secondary GC columns outside acceptance criterion
WS	WS-120106-1602	01/12/06	SW-846 8081A	p,p'-DDE	2 2 T	µg/kg	CONF	209 7	%	J	None	Datum is estimated, bias unknown; %D between primary and secondary GC columns outside acceptance criterion
WS	WS-120106-1602	01/12/06	SW-846 8082	2,2',3,4,4',5,5'-Heptachlorobiphenyl	0 41 T	µg/kg	CONF	48 1	%	J	None	Datum is estimated, bias unknown; %D between primary and secondary GC columns outside acceptance criterion
WS	WS-120106-1602	01/12/06	SW-846 8082	2,2',3,4,5'-Pentachlorobiphenyl	0 98	µg/kg	CONF	129 8	%	J	None	Datum is estimated, bias unknown; %D between primary and secondary GC columns outside acceptance criterion
WS	WS-120106-1602	01/12/06	SW-846 8082	2,2',3,4,5,5'-Hexachlorobiphenyl	0 23 T	µg/kg	CONF	305 5	%	J	None	Datum is estimated, bias unknown; %D between primary and secondary GC columns outside acceptance criterion
WS	WS-120106-1602	01/12/06	SW-846 8082	2,2',4,5,5'-Pentachlorobiphenyl	1 5	µg/kg	CONF	52 3	%	J	None	Datum is estimated, bias unknown; %D between primary and secondary GC columns outside acceptance criterion
WS	WS-120106-1602	01/12/06	SW-846 8082	2,3-Dichlorobiphenyl	0 32 T	µg/kg	CONF	376 7	%	J	None	Datum is estimated, bias unknown; %D between primary and secondary GC columns outside acceptance criterion
WS	WS-120106-1602	01/12/06	SW-846 8082	2,4,5-Trichlorobiphenyl	2 7	µg/kg	CONF	689 1	%	J	None	Datum is estimated, bias unknown; %D between primary and secondary GC columns outside acceptance criterion
WS	WS-120106-1602	01/12/06	SW-846 8082	2-Chlorobiphenyl	2 8 T	µg/kg	CONF	1000	%	J	None	Datum is estimated, bias unknown; %D between primary and secondary GC columns outside acceptance criterion
WS	WS-120106-1602	01/12/06	SW-846 8290	1,2,3,6,7,8-Hexachlorodibenzo-p-Dioxin	1 3 T	pg/g	IAR	1 03	N/A	J	None	Datum is estimated, bias unknown; ion abundance ratio outside acceptance criteria
WS	WS-120106-1602	01/12/06	SW-846 8290	1,2,3,7,8,9-Hexachlorodibenzo-p-Dioxin	0 75 T	pg/g	IAR	3 18	N/A	J	None	Datum is estimated, bias unknown; ion abundance ratio outside acceptance criteria

TABLE 1
DATA QUALIFIERS SUMMARY TABLE
DEMONSTRATION TESTING AND FULL-SCALE OPERATION OF THE BIOGENESIS SEDIMENT DECONTAMINATION PROCESS, KEASBEY, NEW JERSEY
(Page 42 of 188)

Location Identification	Sample Identification	Sample Date	Analysis	Analyte	Sample Result	Sample Units	QC Type	QC Result	QC Units	Qualifier	Bias	Comment
WS	WS-120106-1602	01/12/06	SW-846 8290	Octachlorodibenzo-p-dioxin	2500 B	pg/g	LB	0.42 T	pg/g	B	None	Analyte detected in associated blank; sample concentration greater than five times the blank concentration
WS	WS-120106-1602	01/12/06	SW-846 8290	Octachlorodibenzofuran	7.9 T	pg/g	LB	0.26 T	pg/g	B	None	Analyte detected in associated blank; sample concentration greater than five times the blank concentration
RS	RS-190106-1600	01/19/06	SW-846 8270 SIM	Benzo(g,h,i)perylene	1900 D	µg/kg	CVS	-34	%	J	None	Datum is estimated, bias unknown; CVS %D outside acceptance criterion
RS	RS-190106-1600	01/19/06	SW-846 8270 SIM	Dibenz(a,h)anthracene	490 D	µg/kg	CVS	-30	%	J	None	Datum is estimated, bias unknown; CVS %D outside acceptance criterion
RS	RS-190106-1600	01/19/06	SW-846 6010B	Chromium, total	125	mg/kg	MS	179	%	J	High	Datum is estimated, possible high bias; MS recovery outside acceptance criteria
RS	RS-190106-1600	01/19/06	SW-846 6010B	Lead	261	mg/kg	MS	170	%	J	High	Datum is estimated, possible high bias; MS recovery outside acceptance criteria
RS	RS-190106-1600	01/19/06	SW-846 6010B	Zinc	462	mg/kg	MS MSD	231 137	%	J	High	Datum is estimated, possible high bias; MS/MSD recoveries outside acceptance criteria
RS	RS-190106-1600	01/19/06	SW-846 8081A	Endrin	27 TD	µg/kg	CONF	100.8	%	J	None	Datum is estimated, bias unknown; %D between primary and secondary GC columns outside acceptance criterion
RS	RS-190106-1600	01/19/06	SW-846 8081A	Gamma-Chlordane	27 TD	µg/kg	CONF	55.4	%	J	None	Datum is estimated, bias unknown; %D between primary and secondary GC columns outside acceptance criterion
RS	RS-190106-1600	01/19/06	SW-846 8081A	p,p'-DDT	71 TD	µg/kg	CONF	50.5	%	J	None	Datum is estimated, bias unknown; %D between primary and secondary GC columns outside acceptance criterion
RS	RS-190106-1600	01/19/06	SW-846 8082	2,2',3,3',4,4',5,5',6-Nonachlorobiphenyl	6.4 TD	µg/kg	CONF	263.9	%	J	None	Datum is estimated, bias unknown; %D between primary and secondary GC columns outside acceptance criterion
RS	RS-190106-1600	01/19/06	SW-846 8082	2,2',3,3',4,4',5-Heptachlorobiphenyl	24 D	µg/kg	CONF	85.8	%	J	None	Datum is estimated, bias unknown; %D between primary and secondary GC columns outside acceptance criterion
RS	RS-190106-1600	01/19/06	SW-846 8082	2,2',3,4,5'-Pentachlorobiphenyl	20 D	µg/kg	CONF	427.1	%	J	None	Datum is estimated, bias unknown; %D between primary and secondary GC columns outside acceptance criterion
RS	RS-190106-1600	01/19/06	SW-846 8082	2,3-Dichlorobiphenyl	8.2 TD	µg/kg	CONF	66.3	%	J	None	Datum is estimated, bias unknown; %D between primary and secondary GC columns outside acceptance criterion
RS	RS-190106-1600	01/19/06	SW-846 8290	1,2,3,4,6,7,8-Heptachlorodibenzo-p-dioxin	810	pg/g	LB	200	pg/g	UB	None	Analyte considered not detected, analyte detected in associated blank; sample concentration less than five times the blank concentration
RS	RS-190106-1600	01/19/06	SW-846 8290	1,2,3,4,6,7,8-Heptachlorodibenzofuran	790	pg/g	LB	140	pg/g	B	None	Analyte detected in associated blank; sample concentration greater than five times the blank concentration
RS	RS-190106-1600	01/19/06	SW-846 8290	1,2,3,4,7,8,9-Heptachlorodibenzofuran	39	pg/g	LB	120	pg/g	UB	None	Analyte considered not detected, analyte detected in associated blank; sample concentration less than five times the blank concentration

TABLE 1
DATA QUALIFIERS SUMMARY TABLE
DEMONSTRATION TESTING AND FULL-SCALE OPERATION OF THE BIOGENESIS SEDIMENT DECONTAMINATION PROCESS, KEASBEY, NEW JERSEY
(Page43 of 188)

Location Identification	Sample Identification	Sample Date	Analysis	Analyte	Sample Result	Sample Units	QC Type	QC Result	QC Units	Qualifier	Bias	Comment
RS	RS-190106-1600	01/19/06	SW-846 8290	1,2,3,4,7,8-Hexachlorodibenzofuran	240	pg/g	LB	110	pg/g	UB	None	Analyte considered not detected, analyte detected in associated blank; sample concentration less than five times the blank concentration
RS	RS-190106-1600	01/19/06	SW-846 8290	1,2,3,6,7,8-Hexachlorodibenzofuran	58	pg/g	LB	100	pg/g	UB	None	Analyte considered not detected, analyte detected in associated blank; sample concentration less than five times the blank concentration
RS	RS-190106-1600	01/19/06	SW-846 8290	1,2,3,7,8,9-Hexachlorodibenzo-p-Dioxin	44	pg/g	LB	210	pg/g	UB	None	Analyte considered not detected, analyte detected in associated blank; sample concentration less than five times the blank concentration
RS	RS-190106-1600	01/19/06	SW-846 8290	1,2,3,7,8-Pentachlorodibenzo-p-dioxin	11 T	pg/g	IAR	1 89	N/A	J	None	Datum is estimated, bias unknown; ion abundance ratio outside acceptance criteria
RS	RS-190106-1600	01/19/06	SW-846 8290	1,2,3,7,8-Pentachlorodibenzofuran	19 T	pg/g	IAR	1 96	N/A	J	None	Datum is estimated, bias unknown; ion abundance ratio outside acceptance criteria
RS	RS-190106-1600	01/19/06	SW-846 8290	Octachlorodibenzo-p-dioxin	8600	pg/g	LB	700	pg/g	B	None	Analyte detected in associated blank; sample concentration greater than five times the blank concentration
RS	RS-190106-1600	01/19/06	SW-846 8290	Octachlorodibenzofuran	1000	pg/g	LB	260	pg/g	UB	None	Analyte considered not detected, analyte detected in associated blank; sample concentration less than five times the blank concentration
TS	TS-190106-1601	01/19/06	SW-846 8270 SIM	Benzo(g,h,i)perylene	2100 D	µg/kg	CVS	-34	%	J	None	Datum is estimated, bias unknown; CVS %D outside acceptance criterion
TS	TS-190106-1601	01/19/06	SW-846 8270 SIM	Dibenz(a,h)anthracene	540 D	µg/kg	CVS	-30	%	J	None	Datum is estimated, bias unknown; CVS %D outside acceptance criterion
TS	TS-190106-1601	01/19/06	SW-846 8081A	Aldrin	14 TD	µg/kg	CONF	279 5	%	J	None	Datum is estimated, bias unknown; %D between primary and secondary GC columns outside acceptance criterion
TS	TS-190106-1601	01/19/06	SW-846 8081A	Dieldrin	23 TD	µg/kg	CONF	60	%	J	None	Datum is estimated, bias unknown; %D between primary and secondary GC columns outside acceptance criterion
TS	TS-190106-1601	01/19/06	SW-846 8081A	Endrin	25 TD	µg/kg	CONF	194 7	%	J	None	Datum is estimated, bias unknown; %D between primary and secondary GC columns outside acceptance criterion
TS	TS-190106-1601	01/19/06	SW-846 8082	2,2',3,4,4',5,5'-Heptachlorobiphenyl	19 D	µg/kg	CONF	91 1	%	J	None	Datum is estimated, bias unknown; %D between primary and secondary GC columns outside acceptance criterion
TS	TS-190106-1601	01/19/06	SW-846 8082	2,2',3,4,5'-Pentachlorobiphenyl	16 D	µg/kg	CONF	551 2	%	J	None	Datum is estimated, bias unknown; %D between primary and secondary GC columns outside acceptance criterion
TS	TS-190106-1601	01/19/06	SW-846 8082	2-Chlorobiphenyl	17 TD	µg/kg	CONF	1000	%	J	None	Datum is estimated, bias unknown; %D between primary and secondary GC columns outside acceptance criterion
TS	TS-190106-1601	01/19/06	SW-846 8290	1,2,3,4,6,7,8-Heptachlorodibenzo-p-dioxin	140	pg/g	LB	200	pg/g	UB	None	Analyte considered not detected, analyte detected in associated blank; sample concentration less than five times the blank concentration
TS	TS-190106-1601	01/19/06	SW-846 8290	1,2,3,4,6,7,8-Heptachlorodibenzofuran	170	pg/g	LB	140	pg/g	UB	None	Analyte considered not detected, analyte detected in associated blank; sample concentration less than five times the blank concentration

TABLE 1
DATA QUALIFIERS SUMMARY TABLE
DEMONSTRATION TESTING AND FULL-SCALE OPERATION OF THE BIOGENESIS SEDIMENT DECONTAMINATION PROCESS, KEASBEY, NEW JERSEY
(Page44 of 188)

Location Identification	Sample Identification	Sample Date	Analysis	Analyte	Sample Result	Sample Units	QC Type	QC Result	QC Units	Qualifier	Bias	Comment
TS	TS-190106-1601	01/19/06	SW-846 8290	1,2,3,4,7,8,9-Heptachlorodibenzofuran	15	pg/g	LB	120	pg/g	UB	None	Analyte considered not detected, analyte detected in associated blank; sample concentration less than five times the blank concentration
TS	TS-190106-1601	01/19/06	SW-846 8290	1,2,3,4,7,8-Hexachlorodibenzo-p-dioxin	1 7 T	pg/g	IAR	1	N/A	J	None	Datum is estimated, bias unknown; ion abundance ratio outside acceptance criteria
TS	TS-190106-1601	01/19/06	SW-846 8290	1,2,3,4,7,8-Hexachlorodibenzofuran	57	pg/g	LB	110	pg/g	UB	None	Analyte considered not detected, analyte detected in associated blank; sample concentration less than five times the blank concentration
TS	TS-190106-1601	01/19/06	SW-846 8290	1,2,3,6,7,8-Hexachlorodibenzofuran	11	pg/g	LB	100	pg/g	UB	None	Analyte considered not detected, analyte detected in associated blank; sample concentration less than five times the blank concentration
TS	TS-190106-1601	01/19/06	SW-846 8290	1,2,3,7,8,9-Hexachlorodibenzo-p-Dioxin	6 3 T	pg/g	LB	210	pg/g	UB	None	Analyte considered not detected, analyte detected in associated blank; sample concentration less than five times the blank concentration
TS	TS-190106-1601	01/19/06	SW-846 8290	1,2,3,7,8,9-Hexachlorodibenzofuran	16	pg/g	LB	200	pg/g	UB	None	Analyte considered not detected, analyte detected in associated blank; sample concentration less than five times the blank concentration
TS	TS-190106-1601	01/19/06	SW-846 8290	Octachlorodibenzo-p-dioxin	1400	pg/g	LB	700	pg/g	UB	None	Analyte considered not detected, analyte detected in associated blank; sample concentration less than five times the blank concentration
TS	TS-190106-1601	01/19/06	SW-846 8290	Octachlorodibenzofuran	240	pg/g	LB	260	pg/g	UB	None	Analyte considered not detected, analyte detected in associated blank; sample concentration less than five times the blank concentration
WS	WS-190106-1602	01/19/06	SW-846 8270 SIM	Benzo(g,h,i)perylene	320 D	µg/kg	CVS	-34	%	J	None	Datum is estimated, bias unknown; CVS %D outside acceptance criterion
WS	WS-190106-1602	01/19/06	SW-846 8270 SIM	Dibenz(a,h)anthracene	76 D	µg/kg	CVS	-30	%	J	None	Datum is estimated, bias unknown; CVS %D outside acceptance criterion
WS	WS-190106-1602	01/19/06	SW-846 8081A	Alpha-Chlordane	40 TD	µg/kg	CONF	50 6	%	J	None	Datum is estimated, bias unknown; %D between primary and secondary GC columns outside acceptance criterion
WS	WS-190106-1602	01/19/06	SW-846 8081A	Endrin	28 TD	µg/kg	CONF	221 4	%	J	None	Datum is estimated, bias unknown; %D between primary and secondary GC columns outside acceptance criterion
WS	WS-190106-1602	01/19/06	SW-846 8081A	Gamma-Chlordane	24 TD	µg/kg	CONF	93	%	J	None	Datum is estimated, bias unknown; %D between primary and secondary GC columns outside acceptance criterion
WS	WS-190106-1602	01/19/06	SW-846 8081A	p,p'-DDT	67 D	µg/kg	CONF	67 8	%	J	None	Datum is estimated, bias unknown; %D between primary and secondary GC columns outside acceptance criterion
WS	WS-190106-1602	01/19/06	SW-846 8082	2,2',3,4,4',5,5'-Heptachlorobiphenyl	15 D	µg/kg	CONF	93	%	J	None	Datum is estimated, bias unknown; %D between primary and secondary GC columns outside acceptance criterion
WS	WS-190106-1602	01/19/06	SW-846 8082	2,2',3,4,5'-Pentachlorobiphenyl	15 D	µg/kg	CONF	343	%	J	None	Datum is estimated, bias unknown; %D between primary and secondary GC columns outside acceptance criterion
WS	WS-190106-1602	01/19/06	SW-846 8082	2,2',3,4,5,5'-Hexachlorobiphenyl	9 D	µg/kg	CONF	61 6	%	J	None	Datum is estimated, bias unknown; %D between primary and secondary GC columns outside acceptance criterion

TABLE 1
DATA QUALIFIERS SUMMARY TABLE
DEMONSTRATION TESTING AND FULL-SCALE OPERATION OF THE BIOGENESIS SEDIMENT DECONTAMINATION PROCESS, KEASBEY, NEW JERSEY
(Page45 of 188)

Location Identification	Sample Identification	Sample Date	Analysis	Analyte	Sample Result	Sample Units	QC Type	QC Result	QC Units	Qualifier	Bias	Comment
WS	WS-190106-1602	01/19/06	SW-846 8290	1,2,3,4,6,7,8-Heptachlorodibenzo-p-dioxin	240	pg/g	LB	200	pg/g	UB	None	Analyte considered not detected, analyte detected in associated blank; sample concentration less than five times the blank concentration
WS	WS-190106-1602	01/19/06	SW-846 8290	1,2,3,4,6,7,8-Heptachlorodibenzofuran	260	pg/g	LB	140	pg/g	UB	None	Analyte considered not detected, analyte detected in associated blank; sample concentration less than five times the blank concentration
WS	WS-190106-1602	01/19/06	SW-846 8290	1,2,3,4,7,8,9-Heptachlorodibenzofuran	13 T	pg/g	LB	120	pg/g	UB	None	Analyte considered not detected, analyte detected in associated blank; sample concentration less than five times the blank concentration
WS	WS-190106-1602	01/19/06	SW-846 8290	1,2,3,4,7,8-Hexachlorodibenzo-p-dioxin	3 2 T	pg/g	IAR	0 82	N/A	J	None	Datum is estimated, bias unknown; ion abundance ratio outside acceptance criteria
WS	WS-190106-1602	01/19/06	SW-846 8290	1,2,3,4,7,8-Hexachlorodibenzofuran	65	pg/g	LB	110	pg/g	UB	None	Analyte considered not detected, analyte detected in associated blank; sample concentration less than five times the blank concentration
WS	WS-190106-1602	01/19/06	SW-846 8290	1,2,3,6,7,8-Hexachlorodibenzofuran	14 T	pg/g	LB	100	pg/g	UB	None	Analyte considered not detected, analyte detected in associated blank; sample concentration less than five times the blank concentration
WS	WS-190106-1602	01/19/06	SW-846 8290	1,2,3,7,8,9-Hexachlorodibenzo-p-Dioxin	11 T	pg/g	LB	210	pg/g	UB	None	Analyte considered not detected, analyte detected in associated blank; sample concentration less than five times the blank concentration
WS	WS-190106-1602	01/19/06	SW-846 8290	1,2,3,7,8-Pentachlorodibenzofuran	4 8 T	pg/g	IAR	1 29	N/A	J	None	Datum is estimated, bias unknown; ion abundance ratio outside acceptance criteria
WS	WS-190106-1602	01/19/06	SW-846 8290	Octachlorodibenzo-p-dioxin	4800	pg/g	LB	700	pg/g	B	None	Analyte detected in associated blank; sample concentration greater than five times the blank concentration
WS	WS-190106-1602	01/19/06	SW-846 8290	Octachlorodibenzofuran	380	pg/g	LB	260	pg/g	UB	None	Analyte considered not detected, analyte detected in associated blank; sample concentration less than five times the blank concentration
RS	RS-240106-1530	01/24/06	SW-846 6010B	Lead	404	mg/kg	MS	172	%	J	High	Datum is estimated, possible high bias; MS/MSD recoveries outside acceptance criteria
RS	RS-240106-1530	01/24/06	SW-846 6010B	Zinc	755	mg/kg	LB	0 24 T	mg/kg	B	None	Analyte detected in associated blank; sample concentration greater than five times the blank concentration
RS	RS-240106-1530	01/24/06	SW-846 8081A	Aldrin	9 1 TD	µg/kg	CONF	388 2	%	J	None	Datum is estimated, bias unknown; %D between primary and secondary GC columns outside acceptance criterion
RS	RS-240106-1530	01/24/06	SW-846 8081A	beta Endosulfan	19 TD	µg/kg	CONF	223	%	J	None	Datum is estimated, bias unknown; %D between primary and secondary GC columns outside acceptance criterion
RS	RS-240106-1530	01/24/06	SW-846 8081A	Endrin aldehyde	13 TD	µg/kg	CONF	1000	%	J	None	Datum is estimated, bias unknown; %D between primary and secondary GC columns outside acceptance criterion
RS	RS-240106-1530	01/24/06	SW-846 8081A	p,p'-DDD	44 D	µg/kg	CONF	236 5	%	J	None	Datum is estimated, bias unknown; %D between primary and secondary GC columns outside acceptance criterion
RS	RS-240106-1530	01/24/06	SW-846 8081A	p,p'-DDT	36 TD	µg/kg	CONF	190	%	J	None	Datum is estimated, bias unknown; %D between primary and secondary GC columns outside acceptance criterion

TABLE 1
DATA QUALIFIERS SUMMARY TABLE
DEMONSTRATION TESTING AND FULL-SCALE OPERATION OF THE BIOGENESIS SEDIMENT DECONTAMINATION PROCESS, KEASBEY, NEW JERSEY
(Page 46 of 188)

Location Identification	Sample Identification	Sample Date	Analysis	Analyte	Sample Result	Sample Units	QC Type	QC Result	QC Units	Qualifier	Bias	Comment
RS	RS-240106-1530	01/24/06	SW-846 8082	2,2',3,3',4,4',5,5',6-Nonachlorobiphenyl	5.8 TD	µg/kg	CONF	60.5	%	J	None	Datum is estimated, bias unknown; %D between primary and secondary GC columns outside acceptance criterion
RS	RS-240106-1530	01/24/06	SW-846 8082	2,2',3,4,4',5,5'-Heptachlorobiphenyl	21 D	µg/kg	CONF	67	%	J	None	Datum is estimated, bias unknown; %D between primary and secondary GC columns outside acceptance criterion
RS	RS-240106-1530	01/24/06	SW-846 8082	2,2',3,4,5'-Pentachlorobiphenyl	16 D	µg/kg	CONF	490	%	J	None	Datum is estimated, bias unknown; %D between primary and secondary GC columns outside acceptance criterion
RS	RS-240106-1530	01/24/06	SW-846 8082	2,3-Dichlorobiphenyl	8.3 D	µg/kg	CONF	44.5	%	J	None	Datum is estimated, bias unknown; %D between primary and secondary GC columns outside acceptance criterion
RS	RS-240106-1530	01/24/06	SW-846 8290	1,2,3,4,6,7,8-Heptachlorodibenzo-p-dioxin	950	pg/g	LB	0.44 T	pg/g	B	None	Analyte detected in associated blank; sample concentration greater than five times the blank concentration
RS	RS-240106-1530	01/24/06	SW-846 8290	1,2,3,4,6,7,8-Heptachlorodibenzofuran	1100	pg/g	LB	0.33 T	pg/g	B	None	Analyte detected in associated blank; sample concentration greater than five times the blank concentration
RS	RS-240106-1530	01/24/06	SW-846 8290	1,2,3,4,7,8,9-Heptachlorodibenzofuran	42	pg/g	LB	0.47 T	pg/g	B	None	Analyte detected in associated blank; sample concentration greater than five times the blank concentration
RS	RS-240106-1530	01/24/06	SW-846 8290	1,2,3,4,7,8-Hexachlorodibenzo-p-dioxin	16 T	pg/g	LB	0.14 T	pg/g	B	None	Analyte detected in associated blank; sample concentration greater than five times the blank concentration
RS	RS-240106-1530	01/24/06	SW-846 8290	1,2,3,4,7,8-Hexachlorodibenzofuran	280	pg/g	LB	0.16 T	pg/g	B	None	Analyte detected in associated blank; sample concentration greater than five times the blank concentration
RS	RS-240106-1530	01/24/06	SW-846 8290	1,2,3,6,7,8-Hexachlorodibenzo-p-Dioxin	58	pg/g	LB	0.16 T	pg/g	B	None	Analyte detected in associated blank; sample concentration greater than five times the blank concentration
RS	RS-240106-1530	01/24/06	SW-846 8290	1,2,3,6,7,8-Hexachlorodibenzofuran	57	pg/g	LB	0.15 T	pg/g	B	None	Analyte detected in associated blank; sample concentration greater than five times the blank concentration
RS	RS-240106-1530	01/24/06	SW-846 8290	1,2,3,7,8,9-Hexachlorodibenzo-p-Dioxin	36 T	pg/g	IAR	1.51	N/A	J	None	Datum is estimated, bias unknown; ion abundance ratio outside acceptance criteria
RS	RS-240106-1530	01/24/06	SW-846 8290	1,2,3,7,8,9-Hexachlorodibenzofuran	4.9 T	pg/g	LB	0.39 T	pg/g	B	None	Analyte detected in associated blank; sample concentration greater than five times the blank concentration
RS	RS-240106-1530	01/24/06	SW-846 8290	1,2,3,7,8-Pentachlorodibenzo-p-dioxin	8.7 T	pg/g	IAR	2.02	N/A	J	None	Datum is estimated, bias unknown; ion abundance ratio outside acceptance criteria

TABLE 1
DATA QUALIFIERS SUMMARY TABLE
DEMONSTRATION TESTING AND FULL-SCALE OPERATION OF THE BIOGENESIS SEDIMENT DECONTAMINATION PROCESS, KEASBEY, NEW JERSEY
(Page47 of 188)

Location Identification	Sample Identification	Sample Date	Analysis	Analyte	Sample Result	Sample Units	QC Type	QC Result	QC Units	Qualifier	Bias	Comment
RS	RS-240106-1530	01/24/06	SW-846 8290	2,3,4,6,7,8-Hexachlorodibenzofuran	37 T	pg/g	LB	0.28 T	pg/g	B	None	Analyte detected in associated blank; sample concentration greater than five times the blank concentration
RS	RS-240106-1530	01/24/06	SW-846 8290	2,3,4,7,8-Pentachlorodibenzofuran	56	pg/g	LB	0.24 T	pg/g	B	None	Analyte detected in associated blank; sample concentration greater than five times the blank concentration
RS	RS-240106-1530	01/24/06	SW-846 8290	Octachlorodibenzo-p-dioxin	10000	pg/g	LB	1.2 T	pg/g	B	None	Analyte detected in associated blank; sample concentration greater than five times the blank concentration
RS	RS-240106-1530	01/24/06	SW-846 8290	Octachlorodibenzofuran	1500	pg/g	LB	1.1 T	pg/g	B	None	Analyte detected in associated blank; sample concentration greater than five times the blank concentration
TS	TS-240106-1630	01/24/06	SW-846 6010B	Zinc	335	mg/kg	LB	0.24 T	mg/kg	B	None	Analyte detected in associated blank; sample concentration greater than five times the blank concentration
TS	TS-240106-1630	01/24/06	SW-846 8081A	Aldrin	6.7 TD	µg/kg	CONF	327.9	%	J	None	Datum is estimated, bias unknown; %D between primary and secondary GC columns outside acceptance criterion
TS	TS-240106-1630	01/24/06	SW-846 8081A	beta Endosulfan	13 TD	µg/kg	CONF	311.3	%	J	None	Datum is estimated, bias unknown; %D between primary and secondary GC columns outside acceptance criterion
TS	TS-240106-1630	01/24/06	SW-846 8081A	Dieldrin	7.1 TD	µg/kg	CONF	127.9	%	J	None	Datum is estimated, bias unknown; %D between primary and secondary GC columns outside acceptance criterion
TS	TS-240106-1630	01/24/06	SW-846 8081A	Endosulfan sulfate	2.1 TD	µg/kg	CONF	165.4	%	J	None	Datum is estimated, bias unknown; %D between primary and secondary GC columns outside acceptance criterion
TS	TS-240106-1630	01/24/06	SW-846 8081A	Endrin	4.5 TD	µg/kg	CONF	209.7	%	J	None	Datum is estimated, bias unknown; %D between primary and secondary GC columns outside acceptance criterion
TS	TS-240106-1630	01/24/06	SW-846 8081A	Endrin aldehyde	15 D	µg/kg	CONF	679.7	%	J	None	Datum is estimated, bias unknown; %D between primary and secondary GC columns outside acceptance criterion
TS	TS-240106-1630	01/24/06	SW-846 8081A	Endrin ketone	13 TD	µg/kg	CONF	88.4	%	J	None	Datum is estimated, bias unknown; %D between primary and secondary GC columns outside acceptance criterion
TS	TS-240106-1630	01/24/06	SW-846 8081A	Heptachlor epoxide	6.7 TD	µg/kg	CONF	123.1	%	J	None	Datum is estimated, bias unknown; %D between primary and secondary GC columns outside acceptance criterion
TS	TS-240106-1630	01/24/06	SW-846 8081A	p,p'-DDD	38 D	µg/kg	CONF	280.1	%	J	None	Datum is estimated, bias unknown; %D between primary and secondary GC columns outside acceptance criterion
TS	TS-240106-1630	01/24/06	SW-846 8082	2,2',3,4,4',5,5'-Heptachlorobiphenyl	18 D	µg/kg	CONF	59	%	J	None	Datum is estimated, bias unknown; %D between primary and secondary GC columns outside acceptance criterion
TS	TS-240106-1630	01/24/06	SW-846 8082	2,2',3,4,5'-Pentachlorobiphenyl	15 D	µg/kg	CONF	501.2	%	J	None	Datum is estimated, bias unknown; %D between primary and secondary GC columns outside acceptance criterion

TABLE 1
DATA QUALIFIERS SUMMARY TABLE
DEMONSTRATION TESTING AND FULL-SCALE OPERATION OF THE BIOGENESIS SEDIMENT DECONTAMINATION PROCESS, KEASBEY, NEW JERSEY
(Page 48 of 188)

Location Identification	Sample Identification	Sample Date	Analysis	Analyte	Sample Result	Sample Units	QC Type	QC Result	QC Units	Qualifier	Bias	Comment
TS	TS-240106-1630	01/24/06	SW-846 8270C	Benzo(a)anthracene	1700 TD	µg/kg	MSD	147	%	J	High	Datum is estimated, possible high bias; MSD recovery outside acceptance criteria
TS	TS-240106-1630	01/24/06	SW-846 8270C	Benzo(a)pyrene	1800 TD	µg/kg	MSD	136	%	J	High	Datum is estimated, possible high bias; MSD recovery outside acceptance criteria
TS	TS-240106-1630	01/24/06	SW-846 8270C	Benzo(b)fluoranthene	2200 TD	µg/kg	MSD	133	%	J	High	Datum is estimated, possible high bias; MSD recovery outside acceptance criteria
TS	TS-240106-1630	01/24/06	SW-846 8270C	Benzo(k)fluoranthene	730 TD	µg/kg	MSD	122	%	J	High	Datum is estimated, possible high bias; MSD recovery outside acceptance criteria
TS	TS-240106-1630	01/24/06	SW-846 8270C	Chrysene	2100 TD	µg/kg	MSD	154	%	J	High	Datum is estimated, possible high bias; MSD recovery outside acceptance criteria
TS	TS-240106-1630	01/24/06	SW-846 8270C	Fluoranthene	3500 TD	µg/kg	MS MSD	190 287	%	J	High	Datum is estimated, possible high bias; MS/MSD recoveries outside acceptance criteria
TS	TS-240106-1630	01/24/06	SW-846 8270C	Pyrene	3000 TD	µg/kg	MS MSD	139 196	%	J	High	Datum is estimated, possible high bias; MS/MSD recoveries outside acceptance criteria
TS	TS-240106-1630	01/24/06	SW-846 8290	1,2,3,4,6,7,8-Heptachlorodibenzo-p-dioxin	350	pg/g	LB	0.44 T	pg/g	B	None	Analyte detected in associated blank; sample concentration greater than five times the blank concentration
TS	TS-240106-1630	01/24/06	SW-846 8290	1,2,3,4,6,7,8-Heptachlorodibenzofuran	390	pg/g	LB	0.33 T	pg/g	B	None	Analyte detected in associated blank; sample concentration greater than five times the blank concentration
TS	TS-240106-1630	01/24/06	SW-846 8290	1,2,3,4,7,8,9-Heptachlorodibenzofuran	15	pg/g	LB	0.47 T	pg/g	B	None	Analyte detected in associated blank; sample concentration greater than five times the blank concentration
TS	TS-240106-1630	01/24/06	SW-846 8290	1,2,3,4,7,8-Hexachlorodibenzo-p-dioxin	7.5 T	pg/g	LB	0.14 T	pg/g	B	None	Analyte detected in associated blank; sample concentration greater than five times the blank concentration
TS	TS-240106-1630	01/24/06	SW-846 8290	1,2,3,4,7,8-Hexachlorodibenzofuran	130	pg/g	LB	0.16 T	pg/g	B	None	Analyte detected in associated blank; sample concentration greater than five times the blank concentration
TS	TS-240106-1630	01/24/06	SW-846 8290	1,2,3,6,7,8-Hexachlorodibenzo-p-Dioxin	25	pg/g	LB	0.16 T	pg/g	B	None	Analyte detected in associated blank; sample concentration greater than five times the blank concentration
TS	TS-240106-1630	01/24/06	SW-846 8290	1,2,3,6,7,8-Hexachlorodibenzofuran	30	pg/g	LB	0.15 T	pg/g	B	None	Analyte detected in associated blank; sample concentration greater than five times the blank concentration
TS	TS-240106-1630	01/24/06	SW-846 8290	1,2,3,7,8,9-Hexachlorodibenzofuran	3.9 T	pg/g	LB	0.39 T	pg/g	B	None	Analyte detected in associated blank; sample concentration greater than five times the blank concentration

TABLE 1
DATA QUALIFIERS SUMMARY TABLE
DEMONSTRATION TESTING AND FULL-SCALE OPERATION OF THE BIOGENESIS SEDIMENT DECONTAMINATION PROCESS, KEASBEY, NEW JERSEY
(Page 49 of 188)

Location Identification	Sample Identification	Sample Date	Analysis	Analyte	Sample Result	Sample Units	QC Type	QC Result	QC Units	Qualifier	Bias	Comment
TS	TS-240106-1630	01/24/06	SW-846 8290	2,3,4,6,7,8-Hexachlorodibenzofuran	14	pg/g	LB	0.28 T	pg/g	B	None	Analyte detected in associated blank; sample concentration greater than five times the blank concentration
TS	TS-240106-1630	01/24/06	SW-846 8290	2,3,4,7,8-Pentachlorodibenzofuran	26	pg/g	LB	0.24 T	pg/g	B	None	Analyte detected in associated blank; sample concentration greater than five times the blank concentration
TS	TS-240106-1630	01/24/06	SW-846 8290	Octachlorodibenzo-p-dioxin	3200	pg/g	LB	1.2 T	pg/g	B	None	Analyte detected in associated blank; sample concentration greater than five times the blank concentration
TS	TS-240106-1630	01/24/06	SW-846 8290	Octachlorodibenzofuran	590	pg/g	LB	1.1 T	pg/g	B	None	Analyte detected in associated blank; sample concentration greater than five times the blank concentration
RS	RS-270106-1400	01/27/06	SW-846 6010B	Lead	320	mg/kg	SLD	11	%	J	None	Datum is estimated, bias unknown; serial dilution %D outside acceptance criterion
RS	RS-270106-1400	01/27/06	SW-846 6010B	Nickel	43.4	mg/kg	SLD	10.9	%	J	None	Datum is estimated, bias unknown; serial dilution %D outside acceptance criterion
RS	RS-270106-1400	01/27/06	SW-846 6010B	Zinc	596	mg/kg	SLD LB	15 0.32 T	% mg/kg	JB	None	Datum is estimated, bias unknown; serial dilution percent difference outside acceptance criterion. Analyte detected in associated blank; sample concentration greater than five times the blank concentration
RS	RS-270106-1400	01/27/06	SW-846 8081A	Aldrin	2.5 TD	µg/kg	CONF	345.5	%	J	None	Datum is estimated, bias unknown; %D between primary and secondary GC columns outside acceptance criterion
RS	RS-270106-1400	01/27/06	SW-846 8081A	beta Endosulfan	6.3 TD	µg/kg	CONF	160.2	%	J	None	Datum is estimated, bias unknown; %D between primary and secondary GC columns outside acceptance criterion
RS	RS-270106-1400	01/27/06	SW-846 8081A	Endrin aldehyde	3.2 TD	µg/kg	CONF	1000	%	J	None	Datum is estimated, bias unknown; %D between primary and secondary GC columns outside acceptance criterion
RS	RS-270106-1400	01/27/06	SW-846 8081A	Heptachlor epoxide	2.6 TD	µg/kg	CONF	89.4	%	J	None	Datum is estimated, bias unknown; %D between primary and secondary GC columns outside acceptance criterion
RS	RS-270106-1400	01/27/06	SW-846 8081A	p,p'-DDD	9.8 TD	µg/kg	CONF	296.8	%	J	None	Datum is estimated, bias unknown; %D between primary and secondary GC columns outside acceptance criterion
RS	RS-270106-1400	01/27/06	SW-846 8081A	p,p'-DDT	12 TD	µg/kg	CONF	176.7	%	J	None	Datum is estimated, bias unknown; %D between primary and secondary GC columns outside acceptance criterion
RS	RS-270106-1400	01/27/06	SW-846 8082	2,2',3,4,4',5,5'-Heptachlorobiphenyl	17 D	µg/kg	CONF	70	%	J	None	Datum is estimated, bias unknown; %D between primary and secondary GC columns outside acceptance criterion
RS	RS-270106-1400	01/27/06	SW-846 8082	2,2',3,4,5'-Pentachlorobiphenyl	10 D	µg/kg	CONF	516.2	%	J	None	Datum is estimated, bias unknown; %D between primary and secondary GC columns outside acceptance criterion
RS	RS-270106-1400	01/27/06	SW-846 8290	1,2,3,7,8,9-Hexachlorodibenzofuran	6.4 T	pg/g	IAR	1.69	N/A	J	None	Datum is estimated, bias unknown; ion abundance ratio outside acceptance criteria

TABLE 1
DATA QUALIFIERS SUMMARY TABLE
DEMONSTRATION TESTING AND FULL-SCALE OPERATION OF THE BIOGENESIS SEDIMENT DECONTAMINATION PROCESS, KEASBEY, NEW JERSEY
(Page50 of 188)

Location Identification	Sample Identification	Sample Date	Analysis	Analyte	Sample Result	Sample Units	QC Type	QC Result	QC Units	Qualifier	Bias	Comment
RS	RS-270106-1400	01/27/06	SW-846 8290	1,2,3,7,8-Pentachlorodibenzo-p-dioxin	9.6 T	pg/g	IAR	1.94	N/A	J	None	Datum is estimated, bias unknown; ion abundance ratio outside acceptance criteria
RS	RS-270106-1400	01/27/06	SW-846 8290	Octachlorodibenzo-p-dioxin	9300	pg/g	LB	0.45 T	pg/g	B	None	Analyte detected in associated blank; sample concentration greater than five times the blank concentration
TS	TS-270106-1401	01/27/06	SW-846 6010B	Zinc	255	mg/kg	LB	0.32 T	mg/kg	B	None	Analyte detected in associated blank; sample concentration greater than five times the blank concentration
TS	TS-270106-1401	01/27/06	SW-846 8081A	Aldrin	1.6 TD	µg/kg	CONF	148	%	J	None	Datum is estimated, bias unknown; %D between primary and secondary GC columns outside acceptance criterion
TS	TS-270106-1401	01/27/06	SW-846 8081A	beta Endosulfan	9 D	µg/kg	CONF	249.5	%	J	None	Datum is estimated, bias unknown; %D between primary and secondary GC columns outside acceptance criterion
TS	TS-270106-1401	01/27/06	SW-846 8081A	Endosulfan sulfate	1.4 TD	µg/kg	CONF	112.8	%	J	None	Datum is estimated, bias unknown; %D between primary and secondary GC columns outside acceptance criterion
TS	TS-270106-1401	01/27/06	SW-846 8081A	Endrin	5.7 TD	µg/kg	CONF	52.7	%	J	None	Datum is estimated, bias unknown; %D between primary and secondary GC columns outside acceptance criterion
TS	TS-270106-1401	01/27/06	SW-846 8081A	Endrin aldehyde	9 D	µg/kg	CONF	586.4	%	J	None	Datum is estimated, bias unknown; %D between primary and secondary GC columns outside acceptance criterion
TS	TS-270106-1401	01/27/06	SW-846 8081A	Heptachlor epoxide	4.7 TD	µg/kg	CONF	75.9	%	J	None	Datum is estimated, bias unknown; %D between primary and secondary GC columns outside acceptance criterion
TS	TS-270106-1401	01/27/06	SW-846 8082	2,2',3,4,4',5,5'-Heptachlorobiphenyl	11 D	µg/kg	CONF	81.2	%	J	None	Datum is estimated, bias unknown; %D between primary and secondary GC columns outside acceptance criterion
TS	TS-270106-1401	01/27/06	SW-846 8082	2,2',3,4,5'-Pentachlorobiphenyl	7.2 D	µg/kg	CONF	346.3	%	J	None	Datum is estimated, bias unknown; %D between primary and secondary GC columns outside acceptance criterion
TS	TS-270106-1401	01/27/06	SW-846 8082	2-Chlorobiphenyl	13 TD	µg/kg	CONF	1000	%	J	None	Datum is estimated, bias unknown; %D between primary and secondary GC columns outside acceptance criterion
TS	TS-270106-1401	01/27/06	SW-846 8270C	Benzo(g,h,i)perylene	1700 TD	µg/kg	MSD	28	%	J	Low	Datum is estimated, possible low bias; MSD recovery outside acceptance criteria
TS	TS-270106-1401	01/27/06	SW-846 8290	1,2,3,7,8,9-Hexachlorodibenzo-p-Dioxin	28	pg/g	IAR	1.61	N/A	J	None	Datum is estimated, bias unknown; ion abundance ratio outside acceptance criteria
TS	TS-270106-1401	01/27/06	SW-846 8290	1,2,3,7,8,9-Hexachlorodibenzofuran	3.6 T	pg/g	IAR	1.73	N/A	J	None	Datum is estimated, bias unknown; ion abundance ratio outside acceptance criteria
TS	TS-270106-1401	01/27/06	SW-846 8290	Octachlorodibenzo-p-dioxin	6200	pg/g	LB	0.45 T	pg/g	B	None	Analyte detected in associated blank; sample concentration greater than five times the blank concentration

TABLE 1
DATA QUALIFIERS SUMMARY TABLE
DEMONSTRATION TESTING AND FULL-SCALE OPERATION OF THE BIOGENESIS SEDIMENT DECONTAMINATION PROCESS, KEASBEY, NEW JERSEY
(Page51 of 188)

Location Identification	Sample Identification	Sample Date	Analysis	Analyte	Sample Result	Sample Units	QC Type	QC Result	QC Units	Qualifier	Bias	Comment
TS	TS-270106-1530	01/27/06	SW-846 6010B	Zinc	355	mg/kg	LB	0 32 T	mg/kg	B	None	Analyte detected in associated blank; sample concentration greater than five times the blank concentration
TS	TS-270106-1530	01/27/06	SW-846 8081A	Aldrin	4 1 TD	µg/kg	CONF	383 9	%	J	None	Datum is estimated, bias unknown; %D between primary and secondary GC columns outside acceptance criterion
TS	TS-270106-1530	01/27/06	SW-846 8081A	alpha Endosulfan	1 0 TD	µg/kg	CONF	999	%	J	None	Datum is estimated, bias unknown; %D between primary and secondary GC columns outside acceptance criterion
TS	TS-270106-1530	01/27/06	SW-846 8081A	beta Endosulfan	11 D	µg/kg	CONF	147 4	%	J	None	Datum is estimated, bias unknown; %D between primary and secondary GC columns outside acceptance criterion
TS	TS-270106-1530	01/27/06	SW-846 8081A	Endrin	4 0 TD	µg/kg	CONF	48 5	%	J	None	Datum is estimated, bias unknown; %D between primary and secondary GC columns outside acceptance criterion
TS	TS-270106-1530	01/27/06	SW-846 8081A	Endrin aldehyde	3 1 TD	µg/kg	CONF	1000	%	J	None	Datum is estimated, bias unknown; %D between primary and secondary GC columns outside acceptance criterion
TS	TS-270106-1530	01/27/06	SW-846 8081A	Heptachlor epoxide	2 7 TD	µg/kg	CONF	225	%	J	None	Datum is estimated, bias unknown; %D between primary and secondary GC columns outside acceptance criterion
TS	TS-270106-1530	01/27/06	SW-846 8081A	p,p'-DDD	26 D	µg/kg	CONF	89 1	%	J	None	Datum is estimated, bias unknown; %D between primary and secondary GC columns outside acceptance criterion
TS	TS-270106-1530	01/27/06	SW-846 8082	2,2',3,4,4',5,5'-Heptachlorobiphenyl	9 5 D	µg/kg	CONF	74 5	%	J	None	Datum is estimated, bias unknown; %D between primary and secondary GC columns outside acceptance criterion
TS	TS-270106-1530	01/27/06	SW-846 8082	2,2',3,4,5'-Pentachlorobiphenyl	8 D	µg/kg	CONF	469 2	%	J	None	Datum is estimated, bias unknown; %D between primary and secondary GC columns outside acceptance criterion
TS	TS-270106-1530	01/27/06	SW-846 8082	2,3-Dichlorobiphenyl	4 4 D	µg/kg	CONF	259 3	%	J	None	Datum is estimated, bias unknown; %D between primary and secondary GC columns outside acceptance criterion
TS	TS-270106-1530	01/27/06	SW-846 8082	2-Chlorobiphenyl	17 TD	µg/kg	CONF	706 3	%	J	None	Datum is estimated, bias unknown; %D between primary and secondary GC columns outside acceptance criterion
TS	TS-270106-1530	01/27/06	SW-846 8270C	Benzo(g,h,i)perylene	910 TD	µg/kg	MSD	28	%	J	Low	Datum is estimated, possible low bias; MSD recovery outside acceptance criteria
TS	TS-270106-1530	01/27/06	SW-846 8290	1,2,3,7,8,9-Hexachlorodibenzofuran	1 4 T	pg/g	IAR	1 52	N/A	J	None	Datum is estimated, bias unknown; ion abundance ratio outside acceptance criteria
TS	TS-270106-1530	01/27/06	SW-846 8290	Octachlorodibenzo-p-dioxin	1200	pg/g	LB	0 45 T	pg/g	B	None	Analyte detected in associated blank; sample concentration greater than five times the blank concentration
WS	WS-270106-1402	01/27/06	SW-846 6010B	Zinc	1280	mg/kg	LB	0 32 T	mg/kg	B	None	Analyte detected in associated blank; sample concentration greater than five times the blank concentration

TABLE 1
DATA QUALIFIERS SUMMARY TABLE
DEMONSTRATION TESTING AND FULL-SCALE OPERATION OF THE BIOGENESIS SEDIMENT DECONTAMINATION PROCESS, KEASBEY, NEW JERSEY
(Page52 of 188)

Location Identification	Sample Identification	Sample Date	Analysis	Analyte	Sample Result	Sample Units	QC Type	QC Result	QC Units	Qualifier	Bias	Comment
WS	WS-270106-1402	01/27/06	SW-846 8081A	Aldrin	4 3 TD	µg/kg	CONF	416	%	J	None	Datum is estimated, bias unknown; %D between primary and secondary GC columns outside acceptance criterion
WS	WS-270106-1402	01/27/06	SW-846 8081A	beta Endosulfan	11 TD	µg/kg	CONF	189	%	J	None	Datum is estimated, bias unknown; %D between primary and secondary GC columns outside acceptance criterion
WS	WS-270106-1402	01/27/06	SW-846 8081A	Endrin aldehyde	10 TD	µg/kg	CONF	1000	%	J	None	Datum is estimated, bias unknown; %D between primary and secondary GC columns outside acceptance criterion
WS	WS-270106-1402	01/27/06	SW-846 8081A	Endrin ketone	12 TD	µg/kg	CONF	52 7	%	J	None	Datum is estimated, bias unknown; %D between primary and secondary GC columns outside acceptance criterion
WS	WS-270106-1402	01/27/06	SW-846 8081A	Heptachlor epoxide	4 7 TD	µg/kg	CONF	95 1	%	J	None	Datum is estimated, bias unknown; %D between primary and secondary GC columns outside acceptance criterion
WS	WS-270106-1402	01/27/06	SW-846 8081A	p,p'-DDD	22 D	µg/kg	CONF	240 7	%	J	None	Datum is estimated, bias unknown; %D between primary and secondary GC columns outside acceptance criterion
WS	WS-270106-1402	01/27/06	SW-846 8081A	p,p'-DDT	24 D	µg/kg	CONF	81 7	%	J	None	Datum is estimated, bias unknown; %D between primary and secondary GC columns outside acceptance criterion
WS	WS-270106-1402	01/27/06	SW-846 8082	2,2',3,4,4',5,5'-Heptachlorobiphenyl	11 D	µg/kg	CONF	85 2	%	J	None	Datum is estimated, bias unknown; %D between primary and secondary GC columns outside acceptance criterion
WS	WS-270106-1402	01/27/06	SW-846 8082	2,2',3,4,5'-Pentachlorobiphenyl	7 7 D	µg/kg	CONF	495 4	%	J	None	Datum is estimated, bias unknown; %D between primary and secondary GC columns outside acceptance criterion
WS	WS-270106-1402	01/27/06	SW-846 8082	2,3-Dichlorobiphenyl	2 9 TD	µg/kg	CONF	67 3	%	J	None	Datum is estimated, bias unknown; %D between primary and secondary GC columns outside acceptance criterion
WS	WS-270106-1402	01/27/06	SW-846 8290	1,2,3,4,7,8-Hexachlorodibenzo-p-dioxin	4 8 T	pg/g	IAR	0 82	N/A	J	None	Datum is estimated, bias unknown; ion abundance ratio outside acceptance criteria
WS	WS-270106-1402	01/27/06	SW-846 8290	1,2,3,6,7,8-Hexachlorodibenzo-p-Dioxin	19	pg/g	IAR	0 97	N/A	J	None	Datum is estimated, bias unknown; ion abundance ratio outside acceptance criteria
WS	WS-270106-1402	01/27/06	SW-846 8290	1,2,3,7,8,9-Hexachlorodibenzo-p-Dioxin	16 T	pg/g	IAR	1	N/A	J	None	Datum is estimated, bias unknown; ion abundance ratio outside acceptance criteria
WS	WS-270106-1402	01/27/06	SW-846 8290	1,2,3,7,8,9-Hexachlorodibenzofuran	2 9 T	pg/g	IAR	0 85	N/A	J	None	Datum is estimated, bias unknown; ion abundance ratio outside acceptance criteria
WS	WS-270106-1402	01/27/06	SW-846 8290	1,2,3,7,8-Pentachlorodibenzo-p-dioxin	3 5 T	pg/g	IAR	2 08	N/A	J	None	Datum is estimated, bias unknown; ion abundance ratio outside acceptance criteria
WS	WS-270106-1402	01/27/06	SW-846 8290	2,3,7,8-Tetrachlorodibenzofuran	13	pg/g	IAR	0 92	N/A	J	None	Datum is estimated, bias unknown; ion abundance ratio outside acceptance criteria
WS	WS-270106-1402	01/27/06	SW-846 8290	Octachlorodibenzo-p-dioxin	5500	pg/g	LB	0 45 T	pg/g	B	None	Analyte detected in associated blank; sample concentration greater than five times the blank concentration

TABLE 1
DATA QUALIFIERS SUMMARY TABLE
DEMONSTRATION TESTING AND FULL-SCALE OPERATION OF THE BIOGENESIS SEDIMENT DECONTAMINATION PROCESS, KEASBEY, NEW JERSEY
(Page53 of 188)

Location Identification	Sample Identification	Sample Date	Analysis	Analyte	Sample Result	Sample Units	QC Type	QC Result	QC Units	Qualifier	Bias	Comment
WS	WS-270106-1531	01/27/06	SW-846 6010B	Zinc	1330	mg/kg	LB	0 32 T	mg/kg	B	None	Analyte detected in associated blank; sample concentration greater than five times the blank concentration
WS	WS-270106-1531	01/27/06	SW-846 8081A	Aldrin	2 1 TD	µg/kg	CONF	306 8	%	J	None	Datum is estimated, bias unknown; %D between primary and secondary GC columns outside acceptance criterion
WS	WS-270106-1531	01/27/06	SW-846 8081A	beta Endosulfan	4 0 TD	µg/kg	CONF	274 7	%	J	None	Datum is estimated, bias unknown; %D between primary and secondary GC columns outside acceptance criterion
WS	WS-270106-1531	01/27/06	SW-846 8081A	Dieldrin	1 8 TD	µg/kg	CONF	278	%	J	None	Datum is estimated, bias unknown; %D between primary and secondary GC columns outside acceptance criterion
WS	WS-270106-1531	01/27/06	SW-846 8081A	Heptachlor epoxide	2 3 TD	µg/kg	CONF	49 4	%	J	None	Datum is estimated, bias unknown; %D between primary and secondary GC columns outside acceptance criterion
WS	WS-270106-1531	01/27/06	SW-846 8081A	p,p'-DDD	6 2 TD	µg/kg	CONF	472 4	%	J	None	Datum is estimated, bias unknown; %D between primary and secondary GC columns outside acceptance criterion
WS	WS-270106-1531	01/27/06	SW-846 8081A	p,p'-DDE	10 TD	µg/kg	CONF	60 6	%	J	None	Datum is estimated, bias unknown; %D between primary and secondary GC columns outside acceptance criterion
WS	WS-270106-1531	01/27/06	SW-846 8081A	p,p'-DDT	8 0 TD	µg/kg	CONF	425 6	%	J	None	Datum is estimated, bias unknown; %D between primary and secondary GC columns outside acceptance criterion
WS	WS-270106-1531	01/27/06	SW-846 8082	2,2',3,4,4',5,5'-Heptachlorobiphenyl	8 2 D	µg/kg	CONF	59 3	%	J	None	Datum is estimated, bias unknown; %D between primary and secondary GC columns outside acceptance criterion
WS	WS-270106-1531	01/27/06	SW-846 8082	2,2',3,4,5'-Pentachlorobiphenyl	5 3 TD	µg/kg	CONF	522	%	J	None	Datum is estimated, bias unknown; %D between primary and secondary GC columns outside acceptance criterion
WS	WS-270106-1531	01/27/06	SW-846 8290	1,2,3,7,8-Pentachlorodibenzo-p-dioxin	3 8 T	pg/g	IAR	1 81	N/A	J	None	Datum is estimated, bias unknown; ion abundance ratio outside acceptance criteria
WS	WS-270106-1531	01/27/06	SW-846 8290	Octachlorodibenzo-p-dioxin	5300	pg/g	LB	0 45 T	pg/g	B	None	Analyte detected in associated blank; sample concentration greater than five times the blank concentration
RS	RS-300106-1700	01/30/06	SW-846 6010B	Chromium, total	87 7	mg/kg	MS	126	%	J	High	Datum is estimated, possible high bias; MS recovery outside acceptance criteria
RS	RS-300106-1700	01/30/06	SW-846 6010B	Zinc	352	mg/kg	MS SLD LB	133 10 2 0 22 T	% % mg/kg	JB	High	Datum is estimated, possible high bias; MS recovery and serial dilution %D outside acceptance criteria Analyte detected in associated blank; sample concentration greater than five times the blank concentration
RS	RS-300106-1700	01/30/06	SW-846 8081A	Gamma-Chlordane	6 3 TD	µg/kg	CONF	1000	%	J	None	Datum is estimated, bias unknown; %D between primary and secondary GC columns outside acceptance criterion
RS	RS-300106-1700	01/30/06	SW-846 8081A	p,p'-DDD	20 TD	µg/kg	CONF	61 6	%	J	None	Datum is estimated, bias unknown; %D between primary and secondary GC columns outside acceptance criterion

TABLE 1
DATA QUALIFIERS SUMMARY TABLE
DEMONSTRATION TESTING AND FULL-SCALE OPERATION OF THE BIOGENESIS SEDIMENT DECONTAMINATION PROCESS, KEASBEY, NEW JERSEY
(Page54 of 188)

Location Identification	Sample Identification	Sample Date	Analysis	Analyte	Sample Result	Sample Units	QC Type	QC Result	QC Units	Qualifier	Bias	Comment
RS	RS-300106-1700	01/30/06	SW-846 8082	2,2',3,4,4',5,5'-Heptachlorobiphenyl	6 6 D	µg/kg	CONF	56	%	J	None	Datum is estimated, bias unknown; %D between primary and secondary GC columns outside acceptance criterion
RS	RS-300106-1700	01/30/06	SW-846 8082	2,2',3,4,5'-Pentachlorobiphenyl	6 2 D	µg/kg	CONF	407 5	%	J	None	Datum is estimated, bias unknown; %D between primary and secondary GC columns outside acceptance criterion
RS	RS-300106-1700	01/30/06	SW-846 8082	2-Chlorobiphenyl	13 TD	µg/kg	CONF	216 2	%	J	None	Datum is estimated, bias unknown; %D between primary and secondary GC columns outside acceptance criterion
RS	RS-300106-1700	01/30/06	SW-846 8290	1,2,3,4,6,7,8-Heptachlorodibenzo-p-dioxin	340	pg/g	LB	0 14 T	pg/g	B	None	Analyte detected in associated blank; sample concentration greater than five times the blank concentration
RS	RS-300106-1700	01/30/06	SW-846 8290	1,2,3,4,6,7,8-Heptachlorodibenzofuran	260	pg/g	LB	0 11 T	pg/g	B	None	Analyte detected in associated blank; sample concentration greater than five times the blank concentration
RS	RS-300106-1700	01/30/06	SW-846 8290	1,2,3,4,7,8-Hexachlorodibenzo-p-dioxin	4 0 T	pg/g	IAR	1 46	N/A	J	None	Datum is estimated, bias unknown; ion abundance ratio outside acceptance criteria
RS	RS-300106-1700	01/30/06	SW-846 8290	1,2,3,7,8,9-Hexachlorodibenzofuran	1 2 T	pg/g	IAR	1 53	N/A	J	None	Datum is estimated, bias unknown; ion abundance ratio outside acceptance criteria
RS	RS-300106-1700	01/30/06	SW-846 8290	2,3,7,8-Tetrachlorodibenzofuran	7 7	pg/g	IAR	2 54	N/A	J	None	Datum is estimated, bias unknown; ion abundance ratio outside acceptance criteria
RS	RS-300106-1700	01/30/06	SW-846 8290	Octachlorodibenzo-p-dioxin	9800	pg/g	LB	0 51 T	pg/g	B	None	Analyte detected in associated blank; sample concentration greater than five times the blank concentration
RS	RS-300106-1700	01/30/06	SW-846 8290	Octachlorodibenzofuran	390	pg/g	LB	0 19 T	pg/g	B	None	Analyte detected in associated blank; sample concentration greater than five times the blank concentration
WS2	WS2-300106-1702	01/30/06	SW-846 6010B	Zinc	574	mg/kg	SLD LB	10 2 0 22 T	% mg/kg	JB	None	Datum is estimated, bias unknown; serial dilution percent difference outside acceptance criterion Analyte detected in associated blank; sample concentration greater than five times the blank concentration
WS2	WS2-300106-1702	01/30/06	SW-846 8081A	Aldrin	7 6 TD	µg/kg	CONF	120 1	%	J	None	Datum is estimated, bias unknown; %D between primary and secondary GC columns outside acceptance criterion
WS2	WS2-300106-1702	01/30/06	SW-846 8081A	Alpha-Chlordane	19 D	µg/kg	CONF	49 7	%	J	None	Datum is estimated, bias unknown; %D between primary and secondary GC columns outside acceptance criterion
WS2	WS2-300106-1702	01/30/06	SW-846 8081A	Dieldrin	5 1 TD	µg/kg	CONF	71	%	J	None	Datum is estimated, bias unknown; %D between primary and secondary GC columns outside acceptance criterion
WS2	WS2-300106-1702	01/30/06	SW-846 8081A	Endrin	6 6 TD	µg/kg	CONF	209 9	%	J	None	Datum is estimated, bias unknown; %D between primary and secondary GC columns outside acceptance criterion
WS2	WS2-300106-1702	01/30/06	SW-846 8081A	Gamma-Chlordane	18 D	µg/kg	CONF	79 3	%	J	None	Datum is estimated, bias unknown; %D between primary and secondary GC columns outside acceptance criterion

TABLE 1
DATA QUALIFIERS SUMMARY TABLE
DEMONSTRATION TESTING AND FULL-SCALE OPERATION OF THE BIOGENESIS SEDIMENT DECONTAMINATION PROCESS, KEASBEY, NEW JERSEY
(Page55 of 188)

Location Identification	Sample Identification	Sample Date	Analysis	Analyte	Sample Result	Sample Units	QC Type	QC Result	QC Units	Qualifier	Bias	Comment
WS2	WS2-300106-1702	01/30/06	SW-846 8081A	Heptachlor epoxide	2.4 TD	µg/kg	CONF	279.7	%	J	None	Datum is estimated, bias unknown; %D between primary and secondary GC columns outside acceptance criterion
WS2	WS2-300106-1702	01/30/06	SW-846 8082	2,2',3,4,4',5,5'-Heptachlorobiphenyl	21 D	µg/kg	CONF	54.1	%	J	None	Datum is estimated, bias unknown; %D between primary and secondary GC columns outside acceptance criterion
WS2	WS2-300106-1702	01/30/06	SW-846 8082	2,2',3,4,5'-Pentachlorobiphenyl	14 D	µg/kg	CONF	614.2	%	J	None	Datum is estimated, bias unknown; %D between primary and secondary GC columns outside acceptance criterion
WS2	WS2-300106-1702	01/30/06	SW-846 8082	2-Chlorobiphenyl	31 TD	µg/kg	CONF	1000	%	J	None	Datum is estimated, bias unknown; %D between primary and secondary GC columns outside acceptance criterion
WS2	WS2-300106-1702	01/30/06	SW-846 8290	1,2,3,4,6,7,8-Heptachlorodibenzo-p-dioxin	500	pg/g	MS MSD LB	138 253 0.14 T	% % pg/g	JB	High	Datum is estimated, possible high bias; MS/MSD recoveries outside acceptance criteria. Analyte detected in associated blank; sample concentration greater than five times blank concentration
WS2	WS2-300106-1702	01/30/06	SW-846 8290	1,2,3,4,6,7,8-Heptachlorodibenzofuran	570	pg/g	MS MSD LB	145 252 0.11 T	% % pg/g	JB	High	Datum is estimated, possible high bias; MS/MSD recoveries outside acceptance criteria. Analyte detected in associated blank; sample concentration greater than five times blank concentration
WS2	WS2-300106-1702	01/30/06	SW-846 8290	1,2,3,4,7,8-Hexachlorodibenzofuran	150	pg/g	MS MSD	122 155	%	J	High	Datum is estimated, possible high bias; MS/MSD recoveries outside acceptance criteria
WS2	WS2-300106-1702	01/30/06	SW-846 8290	1,2,3,7,8,9-Hexachlorodibenzofuran	1.5 T	pg/g	IAR	1.52	N/A	J	None	Datum is estimated, bias unknown; ion abundance ratio outside acceptance criteria
WS2	WS2-300106-1702	01/30/06	SW-846 8290	2,3,4,6,7,8-Hexachlorodibenzofuran	15	pg/g	IAR	0.99	N/A	J	None	Datum is estimated, bias unknown; ion abundance ratio outside acceptance criteria
WS2	WS2-300106-1702	01/30/06	SW-846 8290	2,3,7,8-Tetrachlorodibenzo-p-dioxin	220	pg/g	MS MSD	674 485	%	J	High	Datum is estimated, possible high bias; MS/MSD recoveries outside acceptance criteria
WS2	WS2-300106-1702	01/30/06	SW-846 8290	Octachlorodibenzo-p-dioxin	5800	pg/g	MS MSD LB	416 1270 0.51 T	% % pg/g	JB	High	Datum is estimated, possible high bias; MS/MSD recoveries outside acceptance criteria. Analyte detected in associated blank; sample concentration greater than five times blank concentration
WS2	WS2-300106-1702	01/30/06	SW-846 8290	Octachlorodibenzofuran	610	pg/g	MS MSD LB	155 211 0.19 T	% % pg/g	JB	High	Datum is estimated, possible high bias; MS/MSD recoveries outside acceptance criteria. Analyte detected in associated blank; sample concentration greater than five times blank concentration
RS	RS-310106-1700	01/31/06	SW-846 6010B	Zinc	464	mg/kg	LB	0.18 T	mg/kg	B	None	Analyte detected in associated blank; sample concentration greater than five times the blank concentration
RS	RS-310106-1700	01/31/06	SW-846 8082	2,2',3,3',4,4',5,5',6-Nonachlorobiphenyl	0.42 T	µg/kg	CONF	1000	%	J	None	Datum is estimated, bias unknown; %D between primary and secondary GC columns outside acceptance criterion
RS	RS-310106-1700	01/31/06	SW-846 8082	2,2',3,3',4,4',5-Heptachlorobiphenyl	0.92 T	µg/kg	CONF	115	%	J	None	Datum is estimated, bias unknown; %D between primary and secondary GC columns outside acceptance criterion
RS	RS-310106-1700	01/31/06	SW-846 8082	2,2',3,4,4',5,5'-Heptachlorobiphenyl	1.1 T	µg/kg	CONF	62.6	%	J	None	Datum is estimated, bias unknown; %D between primary and secondary GC columns outside acceptance criterion

TABLE 1
DATA QUALIFIERS SUMMARY TABLE
DEMONSTRATION TESTING AND FULL-SCALE OPERATION OF THE BIOGENESIS SEDIMENT DECONTAMINATION PROCESS, KEASBEY, NEW JERSEY
(Page56 of 188)

Location Identification	Sample Identification	Sample Date	Analysis	Analyte	Sample Result	Sample Units	QC Type	QC Result	QC Units	Qualifier	Bias	Comment
RS	RS-310106-1700	01/31/06	SW-846 8082	2,2',3,4,5'-Pentachlorobiphenyl	2.9	µg/kg	CONF	107.1	%	J	None	Datum is estimated, bias unknown; %D between primary and secondary GC columns outside acceptance criterion
RS	RS-310106-1700	01/31/06	SW-846 8082	2,2',5-Trichlorobiphenyl	7.4	µg/kg	CONF	53.2	%	J	None	Datum is estimated, bias unknown; %D between primary and secondary GC columns outside acceptance criterion
RS	RS-310106-1700	01/31/06	SW-846 8082	2,3-Dichlorobiphenyl	1.2 T	µg/kg	CONF	182.6	%	J	None	Datum is estimated, bias unknown; %D between primary and secondary GC columns outside acceptance criterion
RS	RS-310106-1700	01/31/06	SW-846 8082	2,4,5-Trichlorobiphenyl	7.7	µg/kg	CONF	341	%	J	None	Datum is estimated, bias unknown; %D between primary and secondary GC columns outside acceptance criterion
RS	RS-310106-1700	01/31/06	SW-846 8290	1,2,3,4,7,8-Hexachlorodibenzofuran	5.8 T	pg/g	IAR	1.64	N/A	J	None	Datum is estimated, bias unknown; ion abundance ratio outside acceptance criteria
RS	RS-310106-1700	01/31/06	SW-846 8290	1,2,3,6,7,8-Hexachlorodibenzofuran	2.0 T	pg/g	IAR	0.83	N/A	J	None	Datum is estimated, bias unknown; ion abundance ratio outside acceptance criteria
RS	RS-310106-1700	01/31/06	SW-846 8290	1,2,3,7,8-Pentachlorodibenzofuran	1.6 T	pg/g	IAR	1.12	N/A	J	None	Datum is estimated, bias unknown; ion abundance ratio outside acceptance criteria
RS	RS-310106-1700	01/31/06	SW-846 8290	Octachlorodibenzo-p-dioxin	9800	pg/g	LB	0.41 T	pg/g	B	None	Analyte detected in associated blank; sample concentration greater than five times the blank concentration
RS	RS-310106-1700	01/31/06	SW-846 8290	Octachlorodibenzofuran	32 T	pg/g	LB	0.21 T	pg/g	B	None	Analyte detected in associated blank; sample concentration greater than five times the blank concentration
TS	TS-310106-1701	01/31/06	SW-846 6010B	Arsenic	26.2	mg/kg	SLD	14.3	%	J	None	Datum is estimated, bias unknown; serial dilution %D outside acceptance criterion
TS	TS-310106-1701	01/31/06	SW-846 6010B	Barium	81.7	mg/kg	SLD	10.9	%	J	None	Datum is estimated, bias unknown; serial dilution %D outside acceptance criterion
TS	TS-310106-1701	01/31/06	SW-846 6010B	Chromium, total	39.8	mg/kg	MSD SLD	38 14.2	%	J	Low	Datum is estimated, possible low bias; MSD recovery and serial dilution %D outside acceptance criterion
TS	TS-310106-1701	01/31/06	SW-846 6010B	Lead	56.1	mg/kg	SLD	17.7	%	J	None	Datum is estimated, bias unknown; serial dilution %D outside acceptance criterion
TS	TS-310106-1701	01/31/06	SW-846 6010B	Nickel	33.8	mg/kg	MSD SLD	63 16.1	%	J	Low	Datum is estimated, possible low bias; MSD recovery and serial dilution %D outside acceptance criterion
TS	TS-310106-1701	01/31/06	SW-846 6010B	Selenium	2.2	mg/kg	MS	72	%	J	Low	Datum is estimated, possible low bias; MS recovery outside acceptance criteria
TS	TS-310106-1701	01/31/06	SW-846 6010B	Silver	1.1	mg/kg	MS MSD	67 67	%	J	Low	Datum is estimated, possible low bias; MS/MSD recoveries outside acceptance criteria

TABLE 1
DATA QUALIFIERS SUMMARY TABLE
DEMONSTRATION TESTING AND FULL-SCALE OPERATION OF THE BIOGENESIS SEDIMENT DECONTAMINATION PROCESS, KEASBEY, NEW JERSEY
(Page57 of 188)

Location Identification	Sample Identification	Sample Date	Analysis	Analyte	Sample Result	Sample Units	QC Type	QC Result	QC Units	Qualifier	Bias	Comment
TS	TS-310106-1701	01/31/06	SW-846 6010B	Zinc	127	mg/kg	MSD SLD LB	67 20.4 0.18 T	% % mg/kg	JB	Low	Datum is estimated, possible low bias; MSD recovery and serial dilution percent difference outside acceptance criteria. Analyte detected in associated blank. Sample concentration greater than five times the blank concentration.
TS	TS-310106-1701	01/31/06	SW-846 8081A	Aldrin	5.8 TD	µg/kg	CONF	1000	%	J	None	Datum is estimated, bias unknown; %D between primary and secondary GC columns outside acceptance criterion.
TS	TS-310106-1701	01/31/06	SW-846 8081A	Endrin	2.4 TD	µg/kg	CONF	90.1	%	J	None	Datum is estimated, bias unknown; %D between primary and secondary GC columns outside acceptance criterion.
TS	TS-310106-1701	01/31/06	SW-846 8081A	Gamma-Chlordane	2.5 TD	µg/kg	CONF	670.4	%	J	None	Datum is estimated, bias unknown; %D between primary and secondary GC columns outside acceptance criterion.
TS	TS-310106-1701	01/31/06	SW-846 8082	2,2',3,4,4',5,5'-Heptachlorobiphenyl	2.9 D	µg/kg	CONF	66.4	%	J	None	Datum is estimated, bias unknown; %D between primary and secondary GC columns outside acceptance criterion.
TS	TS-310106-1701	01/31/06	SW-846 8082	2,2',3,4,5'-Pentachlorobiphenyl	5.2 D	µg/kg	CONF	191.2	%	J	None	Datum is estimated, bias unknown; %D between primary and secondary GC columns outside acceptance criterion.
TS	TS-310106-1701	01/31/06	SW-846 8082	2,2',3,4,5,5'-Hexachlorobiphenyl	1.4 D	µg/kg	CONF	80.7	%	J	None	Datum is estimated, bias unknown; %D between primary and secondary GC columns outside acceptance criterion.
TS	TS-310106-1701	01/31/06	SW-846 8082	2,2',5'-Tetrachlorobiphenyl	18 D	µg/kg	CONF	56.8	%	J	None	Datum is estimated, bias unknown; %D between primary and secondary GC columns outside acceptance criterion.
TS	TS-310106-1701	01/31/06	SW-846 8082	2,2',5'-Trichlorobiphenyl	14 D	µg/kg	CONF	430.7	%	J	None	Datum is estimated, bias unknown; %D between primary and secondary GC columns outside acceptance criterion.
TS	TS-310106-1701	01/31/06	SW-846 8082	2,4,5'-Trichlorobiphenyl	16 D	µg/kg	CONF	170.6	%	J	None	Datum is estimated, bias unknown; %D between primary and secondary GC columns outside acceptance criterion.
TS	TS-310106-1701	01/31/06	SW-846 8082	2-Chlorobiphenyl	0.77 TD	µg/kg	CONF	1000	%	J	None	Datum is estimated, bias unknown; %D between primary and secondary GC columns outside acceptance criterion.
TS	TS-310106-1701	01/31/06	SW-846 8290	1,2,3,6,7,8-Hexachlorodibenzo-p-Dioxin	1.1 T	pg/g	IAR	1.04	N/A	J	None	Datum is estimated, bias unknown; ion abundance ratio outside acceptance criteria.
TS	TS-310106-1701	01/31/06	SW-846 8290	1,2,3,7,8-Pentachlorodibenzofuran	0.89 T	pg/g	IAR	1.22	N/A	J	None	Datum is estimated, bias unknown; ion abundance ratio outside acceptance criteria.
TS	TS-310106-1701	01/31/06	SW-846 8290	Octachlorodibenzo-p-dioxin	420	pg/g	LB	0.41 T	pg/g	B	None	Analyte detected in associated blank; sample concentration greater than five times the blank concentration.
TS	TS-310106-1701	01/31/06	SW-846 8290	Octachlorodibenzofuran	9.4 T	pg/g	LB	0.21 T	pg/g	B	None	Analyte detected in associated blank; sample concentration greater than five times the blank concentration.
WS	WS-310106-1702	01/31/06	SW-846 6010B	Zinc	217	mg/kg	LB	0.18 T	mg/kg	B	None	Analyte detected in associated blank; sample concentration greater than five times the blank concentration.

TABLE 1
DATA QUALIFIERS SUMMARY TABLE
DEMONSTRATION TESTING AND FULL-SCALE OPERATION OF THE BIOGENESIS SEDIMENT DECONTAMINATION PROCESS, KEASBEY, NEW JERSEY
(Page58 of 188)

Location Identification	Sample Identification	Sample Date	Analysis	Analyte	Sample Result	Sample Units	QC Type	QC Result	QC Units	Qualifier	Bias	Comment
WS	WS-310106-1702	01/31/06	SW-846 8082	2,2',3,4,4',5,5'-Heptachlorobiphenyl	2 1 D	µg/kg	CONF	56 5	%	J	None	Datum is estimated, bias unknown; %D between primary and secondary GC columns outside acceptance criterion
WS	WS-310106-1702	01/31/06	SW-846 8082	2,2',3,4,5'-Pentachlorobiphenyl	3 3 D	µg/kg	CONF	223 7	%	J	None	Datum is estimated, bias unknown; %D between primary and secondary GC columns outside acceptance criterion
WS	WS-310106-1702	01/31/06	SW-846 8082	2,2',4,5,5'-Pentachlorobiphenyl	8 D	µg/kg	MS	39	%	J	Low	Datum is estimated, possible low bias; MS recovery outside acceptance criteria
WS	WS-310106-1702	01/31/06	SW-846 8082	2,2',5,5'-Tetrachlorobiphenyl	16 D	µg/kg	MS MSD	180 232	%	J	High	Datum is estimated, possible high bias; MS/MSD recoveries outside acceptance criteria
WS	WS-310106-1702	01/31/06	SW-846 8082	2,2',5-Trichlorobiphenyl	14 D	µg/kg	MS MSD	166 211	%	J	High	Datum is estimated, possible high bias; MS/MSD recoveries outside acceptance criteria
WS	WS-310106-1702	01/31/06	SW-846 8082	2,3',4,4'-Tetrachlorobiphenyl	15 D	µg/kg	MS MSD	204 258	%	J	High	Datum is estimated, possible high bias; MS/MSD recoveries outside acceptance criteria
WS	WS-310106-1702	01/31/06	SW-846 8082	2,4,5-Trichlorobiphenyl	10 D	µg/kg	CONF	64 9	%	J	None	Datum is estimated, bias unknown; %D between primary and secondary GC columns outside acceptance criterion
WS	WS-310106-1702	01/31/06	SW-846 8270C	Benzo(g,h,i)perylene	73 T	µg/kg	MS MSD	43 41	%	J	Low	Datum is estimated, possible low bias; MS/MSD recoveries outside acceptance criteria
WS	WS-310106-1702	01/31/06	SW-846 8270C	Hexachloroethane	<1100	µg/kg	MS MSD	38 39	%	UJ	Low	Possible false negative; MS/MSD recoveries outside acceptance criteria
WS	WS-310106-1702	01/31/06	SW-846 8270C	Indeno(1,2,3-c,d)pyrene	70 T	µg/kg	MSD	49	%	J	Low	Datum is estimated, possible low bias; MSD recovery outside acceptance criteria
WS	WS-310106-1702	01/31/06	SW-846 8290	2,3,4,7,8-Pentachlorodibenzofuran	1 3 T	pg/g	IAR	1 24	N/A	J	None	Datum is estimated, bias unknown; ion abundance ratio outside acceptance criteria
WS	WS-310106-1702	01/31/06	SW-846 8290	Octachlorodibenzo-p-dioxin	4100	pg/g	LB	0 41 T	pg/g	B	None	Analyte detected in associated blank; sample concentration greater than five times the blank concentration
WS	WS-310106-1702	01/31/06	SW-846 8290	Octachlorodibenzofuran	27 T	pg/g	LB	0 21 T	pg/g	B	None	Analyte detected in associated blank; sample concentration greater than five times the blank concentration
RS	RS-010206-1600	02/01/06	SW-846 6010B	Zinc	301	mg/kg	LB	0 18 T	mg/kg	B	None	Analyte detected in associated blank; sample concentration greater than five times the blank concentration
RS	RS-010206-1600	02/01/06	SW-846 8082	2,2',3,3',4,4',5,5',6-Nonachlorobiphenyl	0 79 TD	µg/kg	CONF	124 9	%	J	None	Datum is estimated, bias unknown; %D between primary and secondary GC columns outside acceptance criterion
RS	RS-010206-1600	02/01/06	SW-846 8082	2,2',3,4,4',5,5'-Heptachlorobiphenyl	1 4 TD	µg/kg	CONF	41 3	%	J	None	Datum is estimated, bias unknown; %D between primary and secondary GC columns outside acceptance criterion
RS	RS-010206-1600	02/01/06	SW-846 8082	2,2',3,4,5'-Pentachlorobiphenyl	1 8 D	µg/kg	CONF	999 1	%	J	None	Datum is estimated, bias unknown; %D between primary and secondary GC columns outside acceptance criterion
RS	RS-010206-1600	02/01/06	SW-846 8082	2,2',4,5,5'-Pentachlorobiphenyl	3 5 D	µg/kg	CONF	47 5	%	J	None	Datum is estimated, bias unknown; %D between primary and secondary GC columns outside acceptance criterion

TABLE 1
DATA QUALIFIERS SUMMARY TABLE
DEMONSTRATION TESTING AND FULL-SCALE OPERATION OF THE BIOGENESIS SEDIMENT DECONTAMINATION PROCESS, KEASBEY, NEW JERSEY
(Page59 of 188)

Location Identification	Sample Identification	Sample Date	Analysis	Analyte	Sample Result	Sample Units	QC Type	QC Result	QC Units	Qualifier	Bias	Comment
RS	RS-010206-1600	02/01/06	SW-846 8082	2,2',5-Trichlorobiphenyl	5 6 D	µg/kg	CONF	118 6	%	J	None	Datum is estimated, bias unknown; %D between primary and secondary GC columns outside acceptance criterion
RS	RS-010206-1600	02/01/06	SW-846 8082	2,3-Dichlorobiphenyl	1 2 TD	µg/kg	CONF	238 5	%	J	None	Datum is estimated, bias unknown; %D between primary and secondary GC columns outside acceptance criterion
RS	RS-010206-1600	02/01/06	SW-846 8082	2,4,5-Trichlorobiphenyl	6 2 D	µg/kg	CONF	73	%	J	None	Datum is estimated, bias unknown; %D between primary and secondary GC columns outside acceptance criterion
RS	RS-010206-1600	02/01/06	SW-846 8290	1,2,3,4,7,8-Hexachlorodibenzo-p-Dioxin	2 0 T	pg/g	IAR	1 02	N/A	J	None	Datum is estimated, bias unknown; ion abundance ratio outside acceptance criteria
RS	RS-010206-1600	02/01/06	SW-846 8290	1,2,3,6,7,8-Hexachlorodibenzofuran	4 0 T	pg/g	IAR	1 48	N/A	J	None	Datum is estimated, bias unknown; ion abundance ratio outside acceptance criteria
RS	RS-010206-1600	02/01/06	SW-846 8290	1,2,3,7,8-Pentachlorodibenzo-p-dioxin	1 4 T	pg/g	IAR	1 88	N/A	J	None	Datum is estimated, bias unknown; ion abundance ratio outside acceptance criteria
RS	RS-010206-1600	02/01/06	SW-846 8290	1,2,3,7,8-Pentachlorodibenzofuran	2 3 T	pg/g	IAR	1 09	N/A	J	None	Datum is estimated, bias unknown; ion abundance ratio outside acceptance criteria
RS	RS-010206-1600	02/01/06	SW-846 8290	2,3,7,8-Tetrachlorodibenzo-p-dioxin	4 8	pg/g	IAR	0 92	N/A	J	None	Datum is estimated, bias unknown; ion abundance ratio outside acceptance criteria
RS	RS-010206-1600	02/01/06	SW-846 8290	2,3,7,8-Tetrachlorodibenzofuran	3 6 T	pg/g	IAR	0 59	N/A	J	None	Datum is estimated, bias unknown; ion abundance ratio outside acceptance criteria
RS	RS-010206-1600	02/01/06	SW-846 8290	Octachlorodibenzo-p-Dioxin	10000	pg/g	LB	0 35 T	pg/g	B	None	Analyte detected in associated blank; sample concentration greater than five times the blank concentration
TS	TS-010206-1601	02/01/06	SW-846 6010B	Zinc	112	mg/kg	LB	0 18 T	mg/kg	B	None	Analyte detected in associated blank; sample concentration greater than five times the blank concentration
TS	TS-010206-1601	02/01/06	SW-846 8081A	Dieldrin	3 7 TD	µg/kg	CONF	149 4	%	J	None	Datum is estimated, bias unknown; %D between primary and secondary GC columns outside acceptance criterion
TS	TS-010206-1601	02/01/06	SW-846 8082	2,2',3,3',4,4',5-Heptachlorobiphenyl	0 95 TD	µg/kg	CONF	42 4	%	J	None	Datum is estimated, bias unknown; %D between primary and secondary GC columns outside acceptance criterion
TS	TS-010206-1601	02/01/06	SW-846 8082	2,2',3,4',5,5',6-Heptachlorobiphenyl	0 8 TD	µg/kg	CONF	194 6	%	J	None	Datum is estimated, bias unknown; %D between primary and secondary GC columns outside acceptance criterion
TS	TS-010206-1601	02/01/06	SW-846 8082	2,2',3,4,5'-Pentachlorobiphenyl	1 2 TD	µg/kg	CONF	1000	%	J	None	Datum is estimated, bias unknown; %D between primary and secondary GC columns outside acceptance criterion
TS	TS-010206-1601	02/01/06	SW-846 8082	2,2',3,4,5'-Hexachlorobiphenyl	0 56 TD	µg/kg	CONF	57 2	%	J	None	Datum is estimated, bias unknown; %D between primary and secondary GC columns outside acceptance criterion
TS	TS-010206-1601	02/01/06	SW-846 8082	2,2',4,4',5,5'-Hexachlorobiphenyl	2 6 D	µg/kg	CONF	184 1	%	J	None	Datum is estimated, bias unknown; %D between primary and secondary GC columns outside acceptance criterion

TABLE 1
DATA QUALIFIERS SUMMARY TABLE
DEMONSTRATION TESTING AND FULL-SCALE OPERATION OF THE BIOGENESIS SEDIMENT DECONTAMINATION PROCESS, KEASBEY, NEW JERSEY
(Page60 of 188)

Location Identification	Sample Identification	Sample Date	Analysis	Analyte	Sample Result	Sample Units	QC Type	QC Result	QC Units	Qualifier	Bias	Comment
TS	TS-010206-1601	02/01/06	SW-846 8082	2,2',4,5,5'-Pentachlorobiphenyl	3 1 D	µg/kg	CONF	135 7	%	J	None	Datum is estimated, bias unknown; %D between primary and secondary GC columns outside acceptance criterion
TS	TS-010206-1601	02/01/06	SW-846 8082	2,2',5-Trichlorobiphenyl	11 D	µg/kg	CONF	430 5	%	J	None	Datum is estimated, bias unknown; %D between primary and secondary GC columns outside acceptance criterion
TS	TS-010206-1601	02/01/06	SW-846 8082	2,3',4,4'-Tetrachlorobiphenyl	8 4 D	µg/kg	CONF	57 2	%	J	None	Datum is estimated, bias unknown; %D between primary and secondary GC columns outside acceptance criterion
TS	TS-010206-1601	02/01/06	SW-846 8082	2,4,5-Trichlorobiphenyl	7 D	µg/kg	CONF	60 7	%	J	None	Datum is estimated, bias unknown; %D between primary and secondary GC columns outside acceptance criterion
TS	TS-010206-1601	02/01/06	SW-846 8082	2-Chlorobiphenyl	23 D	µg/kg	CONF	94 1	%	J	None	Datum is estimated, bias unknown; %D between primary and secondary GC columns outside acceptance criterion
TS	TS-010206-1601	02/01/06	SW-846 8290	1,2,3,4,7,8-Hexachlorodibenzo-p-dioxin	0 97 T	pg/g	IAR	1 44	N/A	J	None	Datum is estimated, bias unknown; ion abundance ratio outside acceptance criteria
TS	TS-010206-1601	02/01/06	SW-846 8290	1,2,3,7,8,9-Hexachlorodibenzo-p-Dioxin	3 3 T	pg/g	IAR	1 04	N/A	J	None	Datum is estimated, bias unknown; ion abundance ratio outside acceptance criteria
TS	TS-010206-1601	02/01/06	SW-846 8290	1,2,3,7,8-Pentachlorodibenzo-p-dioxin	1 2 T	pg/g	IAR	1 09	N/A	J	None	Datum is estimated, bias unknown; ion abundance ratio outside acceptance criteria
TS	TS-010206-1601	02/01/06	SW-846 8290	Octachlorodibenzo-p-dioxin	1800	pg/g	LB	0 35 T	pg/g	B	None	Analyte detected in associated blank; sample concentration greater than five times the blank concentration
WS	WS-010206-1602	02/01/06	SW-846 6010B	Zinc	480	mg/kg	LB	0 18 T	mg/kg	B	None	Analyte detected in associated blank; sample concentration greater than five times the blank concentration
WS	WS-010206-1602	02/01/06	SW-846 8081A	Dieldrin	3 3 TD	µg/kg	CONF	42	%	J	None	Datum is estimated, bias unknown; %D between primary and secondary GC columns outside acceptance criterion
WS	WS-010206-1602	02/01/06	SW-846 8082	2,2',3,4,4',5,5'-Heptachlorobiphenyl	8 D	µg/kg	CONF	44 2	%	J	None	Datum is estimated, bias unknown; %D between primary and secondary GC columns outside acceptance criterion
WS	WS-010206-1602	02/01/06	SW-846 8082	2,2',3,4,5'-Pentachlorobiphenyl	6 D	µg/kg	CONF	871 6	%	J	None	Datum is estimated, bias unknown; %D between primary and secondary GC columns outside acceptance criterion
WS	WS-010206-1602	02/01/06	SW-846 8082	2,2',4,5,5'-Pentachlorobiphenyl	13 D	µg/kg	CONF	40 8	%	J	None	Datum is estimated, bias unknown; %D between primary and secondary GC columns outside acceptance criterion
WS	WS-010206-1602	02/01/06	SW-846 8290	1,2,3,4,7,8-Hexachlorodibenzo-p-dioxin	2 0 T	pg/g	IAR	1 52	N/A	J	None	Datum is estimated, bias unknown; ion abundance ratio outside acceptance criteria
WS	WS-010206-1602	02/01/06	SW-846 8290	1,2,3,7,8-Pentachlorodibenzo-p-dioxin	1 5 T	pg/g	IAR	1 24	N/A	J	None	Datum is estimated, bias unknown; ion abundance ratio outside acceptance criteria

TABLE 1
DATA QUALIFIERS SUMMARY TABLE
DEMONSTRATION TESTING AND FULL-SCALE OPERATION OF THE BIOGENESIS SEDIMENT DECONTAMINATION PROCESS, KEASBEY, NEW JERSEY
(Page61 of 188)

Location Identification	Sample Identification	Sample Date	Analysis	Analyte	Sample Result	Sample Units	QC Type	QC Result	QC Units	Qualifier	Bias	Comment
WS	WS-010206-1602	02/01/06	SW-846 8290	Octachlorodibenzo-p-dioxin	4900	pg/g	LB	0 35 T	pg/g	B	None	Analyte detected in associated blank; sample concentration greater than five times the blank concentration
RS	RS-020206-1800	02/02/06	SW-846 6010B	Zinc	364	mg/kg	LB	0 18 T	mg/kg	B	None	Analyte detected in associated blank; sample concentration greater than five times the blank concentration
RS	RS-020206-1800	02/02/06	SW-846 7471A	Mercury	1 8	mg/kg	MS MSD	353 256	%	J	High	Datum is estimated, possible high bias; MS/MSD recoveries outside acceptance criteria
RS	RS-020206-1800	02/02/06	SW-846 8082	2,2',3,4,4',5,5'-Heptachlorobiphenyl	1 4	µg/kg	CONF	43 1	%	J	None	Datum is estimated, bias unknown; %D between primary and secondary GC columns outside acceptance criterion
RS	RS-020206-1800	02/02/06	SW-846 8082	2,2',3,4,5'-Pentachlorobiphenyl	2	µg/kg	CONF	907 4	%	J	None	Datum is estimated, bias unknown; %D between primary and secondary GC columns outside acceptance criterion
RS	RS-020206-1800	02/02/06	SW-846 8082	2,2',5-Trichlorobiphenyl	6 6	µg/kg	CONF	78 7	%	J	None	Datum is estimated, bias unknown; %D between primary and secondary GC columns outside acceptance criterion
RS	RS-020206-1800	02/02/06	SW-846 8082	2,3-Dichlorobiphenyl	1 8	µg/kg	CONF	117 1	%	J	None	Datum is estimated, bias unknown; %D between primary and secondary GC columns outside acceptance criterion
RS	RS-020206-1800	02/02/06	SW-846 8082	2,4,5-Trichlorobiphenyl	6 8	µg/kg	CONF	121	%	J	None	Datum is estimated, bias unknown; %D between primary and secondary GC columns outside acceptance criterion
RS	RS-020206-1800	02/02/06	SW-846 8082	2-Chlorobiphenyl	7 9 T	µg/kg	CONF	83 4	%	J	None	Datum is estimated, bias unknown; %D between primary and secondary GC columns outside acceptance criterion
RS	RS-020206-1800	02/02/06	SW-846 8290	1,2,3,4,7,8-Hexachlorodibenzo-p-dioxin	1 4 T	pg/g	IAR	1 8	N/A	J	None	Datum is estimated, bias unknown; ion abundance ratio outside acceptance criteria
RS	RS-020206-1800	02/02/06	SW-846 8290	1,2,3,6,7,8-Hexachlorodibenzofuran	3 2 T	pg/g	IAR	1 49	N/A	J	None	Datum is estimated, bias unknown; ion abundance ratio outside acceptance criteria
RS	RS-020206-1800	02/02/06	SW-846 8290	2,3,4,6,7,8-Hexachlorodibenzofuran	3 3 T	pg/g	IAR	0 95	N/A	J	None	Datum is estimated, bias unknown; ion abundance ratio outside acceptance criteria
RS	RS-020206-1800	02/02/06	SW-846 8290	2,3,4,7,8-Pentachlorodibenzofuran	3 4 T	pg/g	IAR	1 13	N/A	J	None	Datum is estimated, bias unknown; ion abundance ratio outside acceptance criteria
RS	RS-020206-1800	02/02/06	SW-846 8290	Octachlorodibenzo-p-dioxin	8300	pg/g	LB	0 55 T	pg/g	B	None	Analyte detected in associated blank; sample concentration greater than five times the blank concentration
TS	TS-020206-1801	02/02/06	SW-846 6010B	Arsenic	33 5	mg/kg	SLD	21 7	%	J	None	Datum is estimated, bias unknown; serial dilution %D outside acceptance criterion
TS	TS-020206-1801	02/02/06	SW-846 6010B	Barium	99 9	mg/kg	SLD	14 8	%	J	None	Datum is estimated, bias unknown; serial dilution %D outside acceptance criterion
TS	TS-020206-1801	02/02/06	SW-846 6010B	Chromium, total	31 7	mg/kg	SLD	18	%	J	None	Datum is estimated, bias unknown; serial dilution %D outside acceptance criterion

TABLE 1
DATA QUALIFIERS SUMMARY TABLE
DEMONSTRATION TESTING AND FULL-SCALE OPERATION OF THE BIOGENESIS SEDIMENT DECONTAMINATION PROCESS, KEASBEY, NEW JERSEY
(Page62 of 188)

Location Identification	Sample Identification	Sample Date	Analysis	Analyte	Sample Result	Sample Units	QC Type	QC Result	QC Units	Qualifier	Bias	Comment
TS	TS-020206-1801	02/02/06	SW-846 6010B	Lead	70.7	mg/kg	SLD	19.6	%	J	None	Datum is estimated, bias unknown; serial dilution %D outside acceptance criterion
TS	TS-020206-1801	02/02/06	SW-846 6010B	Nickel	26.4	mg/kg	SLD	19.6	%	J	None	Datum is estimated, bias unknown; serial dilution %D outside acceptance criterion
TS	TS-020206-1801	02/02/06	SW-846 6010B	Zinc	133	mg/kg	SLD LB	23.8 0.18 T	% mg/kg	JB	None	Datum is estimated, bias unknown; serial dilution percent difference outside acceptance criterion. Analyte detected in associated blank; sample concentration greater than five times the blank concentration
TS	TS-020206-1801	02/02/06	SW-846 8081A	p,p'-DDT	6.2 TD	µg/kg	CONF	156.1	%	J	None	Datum is estimated, bias unknown; %D between primary and secondary GC columns outside acceptance criterion
TS	TS-020206-1801	02/02/06	SW-846 8082	2,2',3,4,4',5,5'-Heptachlorobiphenyl	35 D	µg/kg	CONF	56.2	%	J	None	Datum is estimated, bias unknown; %D between primary and secondary GC columns outside acceptance criterion
TS	TS-020206-1801	02/02/06	SW-846 8082	2,2',3,4,5'-Pentachlorobiphenyl	24 D	µg/kg	CONF	76.2	%	J	None	Datum is estimated, bias unknown; %D between primary and secondary GC columns outside acceptance criterion
TS	TS-020206-1801	02/02/06	SW-846 8082	2,2',4,5,5'-Pentachlorobiphenyl	36 D	µg/kg	CONF	59.5	%	J	None	Datum is estimated, bias unknown; %D between primary and secondary GC columns outside acceptance criterion
TS	TS-020206-1801	02/02/06	SW-846 8082	2,2',5-Trichlorobiphenyl	13 D	µg/kg	CONF	303	%	J	None	Datum is estimated, bias unknown; %D between primary and secondary GC columns outside acceptance criterion
TS	TS-020206-1801	02/02/06	SW-846 8082	2,3',4,4'-Tetrachlorobiphenyl	20 D	µg/kg	CONF	150.9	%	J	None	Datum is estimated, bias unknown; %D between primary and secondary GC columns outside acceptance criterion
TS	TS-020206-1801	02/02/06	SW-846 8082	2-Chlorobiphenyl	41 D	µg/kg	CONF	219.5	%	J	None	Datum is estimated, bias unknown; %D between primary and secondary GC columns outside acceptance criterion
TS	TS-020206-1801	02/02/06	SW-846 8290	1,2,3,4,7,8,9-Heptachlorodibenzofuran	1.1 T	pg/g	IAR	1.67	N/A	J	None	Datum is estimated, bias unknown; ion abundance ratio outside acceptance criteria
TS	TS-020206-1801	02/02/06	SW-846 8290	1,2,3,6,7,8-Hexachlorodibenzo-p-Dioxin	2.2 T	pg/g	IAR	1.01	N/A	J	None	Datum is estimated, bias unknown; ion abundance ratio outside acceptance criteria
TS	TS-020206-1801	02/02/06	SW-846 8290	1,2,3,6,7,8-Hexachlorodibenzofuran	1.1 T	pg/g	IAR	1.58	N/A	J	None	Datum is estimated, bias unknown; ion abundance ratio outside acceptance criteria
TS	TS-020206-1801	02/02/06	SW-846 8290	1,2,3,7,8-Pentachlorodibenzo-p-dioxin	0.48 T	pg/g	IAR	0.95	N/A	J	None	Datum is estimated, bias unknown; ion abundance ratio outside acceptance criteria
TS	TS-020206-1801	02/02/06	SW-846 8290	2,3,4,6,7,8-Hexachlorodibenzofuran	1.2 T	pg/g	IAR	1.51	N/A	J	None	Datum is estimated, bias unknown; ion abundance ratio outside acceptance criteria
TS	TS-020206-1801	02/02/06	SW-846 8290	Octachlorodibenzo-p-dioxin	1200	pg/g	LB	0.55 T	pg/g	B	None	Analyte detected in associated blank; sample concentration greater than five times the blank concentration

TABLE 1
DATA QUALIFIERS SUMMARY TABLE
DEMONSTRATION TESTING AND FULL-SCALE OPERATION OF THE BIOGENESIS SEDIMENT DECONTAMINATION PROCESS, KEASBEY, NEW JERSEY
(Page63 of 188)

Location Identification	Sample Identification	Sample Date	Analysis	Analyte	Sample Result	Sample Units	QC Type	QC Result	QC Units	Qualifier	Bias	Comment
WS	WS-020206-1802	02/02/06	SW-846 6010B	Zinc	496	mg/kg	LB	0 18 T	mg/kg	B	None	Analyte detected in associated blank; sample concentration greater than five times the blank concentration
WS	WS-020206-1802	02/02/06	SW-846 8082	2,2',3,4,5'-Pentachlorobiphenyl	1 1	µg/kg	CONF	912	%	J	None	Datum is estimated, bias unknown; %D between primary and secondary GC columns outside acceptance criterion
WS	WS-020206-1802	02/02/06	SW-846 8082	2,2',4,5,5'-Pentachlorobiphenyl	2	µg/kg	CONF	50 9	%	J	None	Datum is estimated, bias unknown; %D between primary and secondary GC columns outside acceptance criterion
WS	WS-020206-1802	02/02/06	SW-846 8082	2,3-Dichlorobiphenyl	0 89	µg/kg	CONF	127	%	J	None	Datum is estimated, bias unknown; %D between primary and secondary GC columns outside acceptance criterion
WS	WS-020206-1802	02/02/06	SW-846 8082	2,4,5-Trichlorobiphenyl	4 1	µg/kg	CONF	599 9	%	J	None	Datum is estimated, bias unknown; %D between primary and secondary GC columns outside acceptance criterion
WS	WS-020206-1802	02/02/06	SW-846 8082	2-Chlorobiphenyl	1 9 T	µg/kg	CONF	590 7	%	J	None	Datum is estimated, bias unknown; %D between primary and secondary GC columns outside acceptance criterion
WS	WS-020206-1802	02/02/06	SW-846 8290	1,2,3,7,8-Pentachlorodibenzofuran	1 6 T	pg/g	IAR	1 22	N/A	J	None	Datum is estimated, bias unknown; ion abundance ratio outside acceptance criteria
WS	WS-020206-1802	02/02/06	SW-846 8290	2,3,7,8-Tetrachlorodibenzofuran	2 2 T	pg/g	IAR	0 94	N/A	J	None	Datum is estimated, bias unknown; ion abundance ratio outside acceptance criteria
WS	WS-020206-1802	02/02/06	SW-846 8290	Octachlorodibenzo-p-dioxin	5100	pg/g	LB	0 55 T	pg/g	B	None	Analyte detected in associated blank; sample concentration greater than five times the blank concentration
RS	RS-030206-1200	02/03/06	SW-846 6010B	Zinc	191	mg/kg	LB	0 18 T	mg/kg	B	None	Analyte detected in associated blank; sample concentration greater than five times the blank concentration
RS	RS-030206-1200	02/03/06	SW-846 8081A	p,p'-DDD	7 2 TD	µg/kg	CONF	213 3	%	J	None	Datum is estimated, bias unknown; %D between primary and secondary GC columns outside acceptance criterion
RS	RS-030206-1200	02/03/06	SW-846 8081A	p,p'-DDE	6 7 TD	µg/kg	CONF	43 5	%	J	None	Datum is estimated, bias unknown; %D between primary and secondary GC columns outside acceptance criterion
RS	RS-030206-1200	02/03/06	SW-846 8081A	p,p'-DDT	22 TD	µg/kg	CONF	174 2	%	J	None	Datum is estimated, bias unknown; %D between primary and secondary GC columns outside acceptance criterion
RS	RS-030206-1200	02/03/06	SW-846 8082	2,2',3,4,4',5,5'-Heptachlorobiphenyl	1 2 TD	µg/kg	CONF	59 7	%	J	None	Datum is estimated, bias unknown; %D between primary and secondary GC columns outside acceptance criterion
RS	RS-030206-1200	02/03/06	SW-846 8082	2,2',3,4,5'-Pentachlorobiphenyl	2 1 TD	µg/kg	CONF	427 8	%	J	None	Datum is estimated, bias unknown; %D between primary and secondary GC columns outside acceptance criterion
RS	RS-030206-1200	02/03/06	SW-846 8082	2,2',5-Trichlorobiphenyl	5 1 D	µg/kg	CONF	98 8	%	J	None	Datum is estimated, bias unknown; %D between primary and secondary GC columns outside acceptance criterion

TABLE 1
DATA QUALIFIERS SUMMARY TABLE
DEMONSTRATION TESTING AND FULL-SCALE OPERATION OF THE BIOGENESIS SEDIMENT DECONTAMINATION PROCESS, KEASBEY, NEW JERSEY
(Page64 of 188)

Location Identification	Sample Identification	Sample Date	Analysis	Analyte	Sample Result	Sample Units	QC Type	QC Result	QC Units	Qualifier	Bias	Comment
RS	RS-030206-1200	02/03/06	SW-846 8082	2,3-Dichlorobiphenyl	1.5 TD	µg/kg	CONF	100.7	%	J	None	Datum is estimated, bias unknown; %D between primary and secondary GC columns outside acceptance criterion
RS	RS-030206-1200	02/03/06	SW-846 8290	1,2,3,4,6,7,8-Heptachlorodibenzofuran	33	pg/g	LB	0.15 T	pg/g	B	None	Analyte detected in associated blank; sample concentration greater than five times the blank concentration
RS	RS-030206-1200	02/03/06	SW-846 8290	1,2,3,4,7,8-Hexachlorodibenzo-p-dioxin	2.1 T	pg/g	IAR	0.97	N/A	J	None	Datum is estimated, bias unknown; ion abundance ratio outside acceptance criteria
RS	RS-030206-1200	02/03/06	SW-846 8290	1,2,3,7,8-Pentachlorodibenzofuran	2.1 T	pg/g	IAR	1.24	N/A	J	None	Datum is estimated, bias unknown; ion abundance ratio outside acceptance criteria
RS	RS-030206-1200	02/03/06	SW-846 8290	2,3,4,6,7,8-Hexachlorodibenzofuran	2.0 T	pg/g	IAR	1.78	N/A	J	None	Datum is estimated, bias unknown; ion abundance ratio outside acceptance criteria
RS	RS-030206-1200	02/03/06	SW-846 8290	Octachlorodibenzo-p-dioxin	8400	pg/g	LB	0.72 T	pg/g	B	None	Analyte detected in associated blank; sample concentration greater than five times the blank concentration
RS	RS-030206-1200	02/03/06	SW-846 8290	Octachlorodibenzofuran	34 T	pg/g	IAR	0.73	N/A	J	None	Datum is estimated, bias unknown; ion abundance ratio outside acceptance criteria
TS	TS-030206-1201	02/03/06	SW-846 6010B	Zinc	135	mg/kg	LB	0.18 T	mg/kg	B	None	Analyte detected in associated blank; sample concentration greater than five times the blank concentration
TS	TS-030206-1201	02/03/06	SW-846 8081A	Aldrin	1.8 TD	µg/kg	CONF	356.9	%	J	None	Datum is estimated, bias unknown; %D between primary and secondary GC columns outside acceptance criterion
TS	TS-030206-1201	02/03/06	SW-846 8081A	Alpha BHC (alpha Hexachlorocyclohexane)	1.8 TD	µg/kg	CONF	595.2	%	J	None	Datum is estimated, bias unknown; %D between primary and secondary GC columns outside acceptance criterion
TS	TS-030206-1201	02/03/06	SW-846 8081A	beta Endosulfan	4.3 TD	µg/kg	CONF	47.2	%	J	None	Datum is estimated, bias unknown; %D between primary and secondary GC columns outside acceptance criterion
TS	TS-030206-1201	02/03/06	SW-846 8081A	Dieldrin	2.5 TD	µg/kg	CONF	134.5	%	J	None	Datum is estimated, bias unknown; %D between primary and secondary GC columns outside acceptance criterion
TS	TS-030206-1201	02/03/06	SW-846 8082	2,2',3,4,4',5,5'-Heptachlorobiphenyl	4.7 D	µg/kg	CONF	40.2	%	J	None	Datum is estimated, bias unknown; %D between primary and secondary GC columns outside acceptance criterion
TS	TS-030206-1201	02/03/06	SW-846 8082	2,2',3,4,5,5'-Hexachlorobiphenyl	1.7 TD	µg/kg	CONF	174.8	%	J	None	Datum is estimated, bias unknown; %D between primary and secondary GC columns outside acceptance criterion
TS	TS-030206-1201	02/03/06	SW-846 8082	2,2',4,4',5,5'-Hexachlorobiphenyl	5.1 D	µg/kg	CONF	163.2	%	J	None	Datum is estimated, bias unknown; %D between primary and secondary GC columns outside acceptance criterion
TS	TS-030206-1201	02/03/06	SW-846 8082	2,2',5,5'-Tetrachlorobiphenyl	21 D	µg/kg	CONF	52.7	%	J	None	Datum is estimated, bias unknown; %D between primary and secondary GC columns outside acceptance criterion

TABLE 1
DATA QUALIFIERS SUMMARY TABLE
DEMONSTRATION TESTING AND FULL-SCALE OPERATION OF THE BIOGENESIS SEDIMENT DECONTAMINATION PROCESS, KEASBEY, NEW JERSEY
(Page65 of 188)

Location Identification	Sample Identification	Sample Date	Analysis	Analyte	Sample Result	Sample Units	QC Type	QC Result	QC Units	Qualifier	Bias	Comment
TS	TS-030206-1201	02/03/06	SW-846 8082	2,2',5-Trichlorobiphenyl	23 D	µg/kg	CONF	647.6	%	J	None	Datum is estimated, bias unknown; %D between primary and secondary GC columns outside acceptance criterion
TS	TS-030206-1201	02/03/06	SW-846 8082	2,3',4,4'-Tetrachlorobiphenyl	17 D	µg/kg	CONF	58.9	%	J	None	Datum is estimated, bias unknown; %D between primary and secondary GC columns outside acceptance criterion
TS	TS-030206-1201	02/03/06	SW-846 8082	2-Chlorobiphenyl	25 TD	µg/kg	CONF	146.3	%	J	None	Datum is estimated, bias unknown; %D between primary and secondary GC columns outside acceptance criterion
TS	TS-030206-1201	02/03/06	SW-846 8290	1,2,3,4,6,7,8-Heptachlorodibenzofuran	4.6 T	pg/g	LB	0.15 T	pg/g	B	None	Analyte detected in associated blank; sample concentration greater than five times the blank concentration
TS	TS-030206-1201	02/03/06	SW-846 8290	1,2,3,6,7,8-Hexachlorodibenzo-p-Dioxin	1.0 T	pg/g	IAR	0.97	N/A	J	None	Datum is estimated, bias unknown; ion abundance ratio outside acceptance criteria
TS	TS-030206-1201	02/03/06	SW-846 8290	1,2,3,6,7,8-Hexachlorodibenzofuran	0.55 T	pg/g	IAR	1.66	N/A	J	None	Datum is estimated, bias unknown; ion abundance ratio outside acceptance criteria
TS	TS-030206-1201	02/03/06	SW-846 8290	2,3,4,6,7,8-Hexachlorodibenzofuran	0.57 T	pg/g	IAR	1.03	N/A	J	None	Datum is estimated, bias unknown; ion abundance ratio outside acceptance criteria
TS	TS-030206-1201	02/03/06	SW-846 8290	2,3,7,8-Tetrachlorodibenzo-p-dioxin	0.79 T	pg/g	IAR	0.91	N/A	J	None	Datum is estimated, bias unknown; ion abundance ratio outside acceptance criteria
TS	TS-030206-1201	02/03/06	SW-846 8290	2,3,7,8-Tetrachlorodibenzofuran	1.1 T	pg/g	IAR	1.05	N/A	J	None	Datum is estimated, bias unknown; ion abundance ratio outside acceptance criteria
TS	TS-030206-1201	02/03/06	SW-846 8290	Octachlorodibenzo-p-dioxin	460	pg/g	LB	0.72 T	pg/g	B	None	Analyte detected in associated blank; sample concentration greater than five times the blank concentration
WS	WS-030206-1202	02/03/06	SW-846 6010B	Zinc	297	mg/kg	LB	0.18 T	mg/kg	B	None	Analyte detected in associated blank; sample concentration greater than five times the blank concentration
WS	WS-030206-1202	02/03/06	SW-846 8081A	p,p'-DDT	3.6 TD	µg/kg	CONF	1000	%	J	None	Datum is estimated, bias unknown; %D between primary and secondary GC columns outside acceptance criterion
WS	WS-030206-1202	02/03/06	SW-846 8082	2,2',3,4,4',5,5'-Heptachlorobiphenyl	2.3 TD	µg/kg	CONF	49	%	J	None	Datum is estimated, bias unknown; %D between primary and secondary GC columns outside acceptance criterion
WS	WS-030206-1202	02/03/06	SW-846 8082	2,2',3,4,5'-Pentachlorobiphenyl	3.5 TD	µg/kg	CONF	598.8	%	J	None	Datum is estimated, bias unknown; %D between primary and secondary GC columns outside acceptance criterion
WS	WS-030206-1202	02/03/06	SW-846 8082	2,2',5-Trichlorobiphenyl	10 D	µg/kg	CONF	85.3	%	J	None	Datum is estimated, bias unknown; %D between primary and secondary GC columns outside acceptance criterion
WS	WS-030206-1202	02/03/06	SW-846 8270C	1,4-Dichlorobenzene	<1200	µg/kg	MS	32	%	UJ	Low	Possible false negative; MS recovery outside acceptance criteria

TABLE 1
DATA QUALIFIERS SUMMARY TABLE
DEMONSTRATION TESTING AND FULL-SCALE OPERATION OF THE BIOGENESIS SEDIMENT DECONTAMINATION PROCESS, KEASBEY, NEW JERSEY
(Page66 of 188)

Location Identification	Sample Identification	Sample Date	Analysis	Analyte	Sample Result	Sample Units	QC Type	QC Result	QC Units	Qualifier	Bias	Comment
WS	WS-030206-1202	02/03/06	SW-846 8270C	Hexachloroethane	<1200	µg/kg	MS	26	%	UJ	Low	Possible false negative; MS recovery outside acceptance criteria
WS	WS-030206-1202	02/03/06	SW-846 8290	1,2,3,4,6,7,8-Heptachlorodibenzofuran	2.2 T	pg/g	IAR LB	1.26 0.15 T	N/A pg/g	JB	None	Datum is estimated, bias unknown; ion abundance ratio outside acceptance criteria. Analyte detected in associated blank; sample concentration greater than five times the blank concentration.
WS	WS-030206-1202	02/03/06	SW-846 8290	1,2,3,4,7,8-Hexachlorodibenzofuran	0.40 T	pg/g	IAR	1	N/A	J	None	Datum is estimated, bias unknown; ion abundance ratio outside acceptance criteria.
WS	WS-030206-1202	02/03/06	SW-846 8290	Octachlorodibenzo-p-dioxin	590	pg/g	LB	0.72 T	pg/g	B	None	Analyte detected in associated blank; sample concentration greater than five times the blank concentration.
RS	RS-060206-1930	02/06/06	SW-846 6010B	Zinc	234	mg/kg	LB	0.2 T	mg/kg	B	None	Analyte detected in associated blank; sample concentration greater than five times the blank concentration.
RS	RS-060206-1930	02/06/06	SW-846 8081A	Dieldrin	2.2 TD	µg/kg	CONF	134.8	%	J	None	Datum is estimated, bias unknown; %D between primary and secondary GC columns outside acceptance criterion.
RS	RS-060206-1930	02/06/06	SW-846 8081A	Endrin	2.2 TD	µg/kg	CONF	71.5	%	J	None	Datum is estimated, bias unknown; %D between primary and secondary GC columns outside acceptance criterion.
RS	RS-060206-1930	02/06/06	SW-846 8082	2,2',3,4,5'-Pentachlorobiphenyl	1.9 TD	µg/kg	CONF	472.8	%	J	None	Datum is estimated, bias unknown; %D between primary and secondary GC columns outside acceptance criterion.
RS	RS-060206-1930	02/06/06	SW-846 8082	2,2',5-Trichlorobiphenyl	5 TD	µg/kg	CONF	113.7	%	J	None	Datum is estimated, bias unknown; %D between primary and secondary GC columns outside acceptance criterion.
RS	RS-060206-1930	02/06/06	SW-846 8082	2,3-Dichlorobiphenyl	1.3 TD	µg/kg	CONF	144.9	%	J	None	Datum is estimated, bias unknown; %D between primary and secondary GC columns outside acceptance criterion.
RS	RS-060206-1930	02/06/06	SW-846 8290	1,2,3,4,6,7,8-Heptachlorodibenzofuran	29	pg/g	LB	0.14 T	pg/g	B	None	Analyte detected in associated blank; sample concentration greater than five times the blank concentration.
RS	RS-060206-1930	02/06/06	SW-846 8290	1,2,3,4,7,8-Hexachlorodibenzo-p-dioxin	2.0 T	pg/g	IAR	1.02	N/A	J	None	Datum is estimated, bias unknown; ion abundance ratio outside acceptance criteria.
RS	RS-060206-1930	02/06/06	SW-846 8290	2,3,4,6,7,8-Hexachlorodibenzofuran	2.4 T	pg/g	IAR LB	1.03 0.11 T	N/A pg/g	JB	None	Datum is estimated, bias unknown; ion abundance ratio outside acceptance criteria. Analyte detected in associated blank; sample concentration greater than five times the blank concentration.
RS	RS-060206-1930	02/06/06	SW-846 8290	Octachlorodibenzo-p-dioxin	7800	pg/g	LB	0.50 T	pg/g	B	None	Analyte detected in associated blank; sample concentration greater than five times the blank concentration.
TS	TS-060206-1931	02/06/06	SW-846 6010B	Arsenic	29.2	mg/kg	SLD	15.4	%	J	None	Datum is estimated, bias unknown; serial dilution %D outside acceptance criterion.

TABLE 1
DATA QUALIFIERS SUMMARY TABLE
DEMONSTRATION TESTING AND FULL-SCALE OPERATION OF THE BIOGENESIS SEDIMENT DECONTAMINATION PROCESS, KEASBEY, NEW JERSEY
(Page67 of 188)

Location Identification	Sample Identification	Sample Date	Analysis	Analyte	Sample Result	Sample Units	QC Type	QC Result	QC Units	Qualifier	Bias	Comment
TS	TS-060206-1931	02/06/06	SW-846 6010B	Chromium, total	26.8	mg/kg	SLD	11.5	%	J	None	Datum is estimated, bias unknown; serial dilution %D outside acceptance criterion
TS	TS-060206-1931	02/06/06	SW-846 6010B	Lead	61.8	mg/kg	MSD SLD	73 14.1	%	J	Low	Datum is estimated, possible low bias; MSD recovery and serial dilution %D outside acceptance criterion
TS	TS-060206-1931	02/06/06	SW-846 6010B	Nickel	23.6	mg/kg	SLD	12.7	%	J	None	Datum is estimated, bias unknown; serial dilution %D outside acceptance criterion
TS	TS-060206-1931	02/06/06	SW-846 6010B	Zinc	124	mg/kg	MS MSD SLD LB	63 70 18 0.2 T	% % % mg/kg	JB	Low	Datum is estimated, possible low bias; MS/MSD recoveries and serial dilution %D outside acceptance criteria. Analyte detected in associated blank; sample concentration greater than five times the blank concentration
TS	TS-060206-1931	02/06/06	SW-846 8081A	Alpha-Chlordane	1.1 TD	µg/kg	CONF	281	%	J	None	Datum is estimated, bias unknown; %D between primary and secondary GC columns outside acceptance criterion
TS	TS-060206-1931	02/06/06	SW-846 8081A	beta Endosulfan	2.5 TD	µg/kg	CONF	59.1	%	J	None	Datum is estimated, bias unknown; %D between primary and secondary GC columns outside acceptance criterion
TS	TS-060206-1931	02/06/06	SW-846 8081A	Dieldrin	2.5 TD	µg/kg	CONF	86	%	J	None	Datum is estimated, bias unknown; %D between primary and secondary GC columns outside acceptance criterion
TS	TS-060206-1931	02/06/06	SW-846 8081A	Endosulfan sulfate	2.1 TD	µg/kg	CONF	83.3	%	J	None	Datum is estimated, bias unknown; %D between primary and secondary GC columns outside acceptance criterion
TS	TS-060206-1931	02/06/06	SW-846 8082	2,2',3,4,4',5,5'-Heptachlorobiphenyl	1.8 TD	µg/kg	CONF	57.1	%	J	None	Datum is estimated, bias unknown; %D between primary and secondary GC columns outside acceptance criterion
TS	TS-060206-1931	02/06/06	SW-846 8082	2,2',3,4,5'-Pentachlorobiphenyl	2.1 TD	µg/kg	CONF	482.8	%	J	None	Datum is estimated, bias unknown; %D between primary and secondary GC columns outside acceptance criterion
TS	TS-060206-1931	02/06/06	SW-846 8082	2,2',3,4,5,5'-Hexachlorobiphenyl	0.65 TD	µg/kg	CONF	151.1	%	J	None	Datum is estimated, bias unknown; %D between primary and secondary GC columns outside acceptance criterion
TS	TS-060206-1931	02/06/06	SW-846 8082	2,2',5,5'-Tetrachlorobiphenyl	9.2 D	µg/kg	CONF	53.5	%	J	None	Datum is estimated, bias unknown; %D between primary and secondary GC columns outside acceptance criterion
TS	TS-060206-1931	02/06/06	SW-846 8082	2,2',5-Trichlorobiphenyl	6.9 D	µg/kg	CONF	550.8	%	J	None	Datum is estimated, bias unknown; %D between primary and secondary GC columns outside acceptance criterion
TS	TS-060206-1931	02/06/06	SW-846 8082	2-Chlorobiphenyl	29 D	µg/kg	CONF	199.3	%	J	None	Datum is estimated, bias unknown; %D between primary and secondary GC columns outside acceptance criterion
TS	TS-060206-1931	02/06/06	SW-846 8290	1,2,3,4,6,7,8-Heptachlorodibenzofuran	4.7 T	pg/g	IAR LB	1.48 0.14 T	N/A pg/g	JB	None	Datum is estimated, bias unknown; ion abundance ratio outside acceptance criteria. Analyte detected in associated blank; sample concentration greater than five times the blank concentration
TS	TS-060206-1931	02/06/06	SW-846 8290	1,2,3,4,7,8,9-Heptachlorodibenzofuran	0.42 T	pg/g	IAR	1.27	N/A	J	None	Datum is estimated, bias unknown; ion abundance ratio outside acceptance criteria

TABLE 1
DATA QUALIFIERS SUMMARY TABLE
DEMONSTRATION TESTING AND FULL-SCALE OPERATION OF THE BIOGENESIS SEDIMENT DECONTAMINATION PROCESS, KEASBEY, NEW JERSEY
(Page68 of 188)

Location Identification	Sample Identification	Sample Date	Analysis	Analyte	Sample Result	Sample Units	QC Type	QC Result	QC Units	Qualifier	Bias	Comment
TS	TS-060206-1931	02/06/06	SW-846 8290	1,2,3,4,7,8-Hexachlorodibenzofuran	1.3 T	pg/g	IAR	1.56	N/A	J	None	Datum is estimated, bias unknown; ion abundance ratio outside acceptance criteria
TS	TS-060206-1931	02/06/06	SW-846 8290	1,2,3,6,7,8-Hexachlorodibenzofuran	0.28 T	pg/g	IAR	2.07	N/A	J	None	Datum is estimated, bias unknown; ion abundance ratio outside acceptance criteria
TS	TS-060206-1931	02/06/06	SW-846 8290	1,2,3,7,8,9-Hexachlorodibenzo-p-Dioxin	0.64 T	pg/g	IAR	1.01	N/A	J	None	Datum is estimated, bias unknown; ion abundance ratio outside acceptance criteria
TS	TS-060206-1931	02/06/06	SW-846 8290	2,3,4,6,7,8-Hexachlorodibenzofuran	0.23 T	pg/g	LB	0.11 T	pg/g	UB	None	Analyte considered not detected, analyte detected in associated blank; sample concentration less than five times the blank concentration
TS	TS-060206-1931	02/06/06	SW-846 8290	2,3,4,7,8-Pentachlorodibenzofuran	0.43 T	pg/g	IAR	1.08	N/A	J	None	Datum is estimated, bias unknown; ion abundance ratio outside acceptance criteria
TS	TS-060206-1931	02/06/06	SW-846 8290	2,3,7,8-Tetrachlorodibenzo-p-dioxin	0.52 T	pg/g	IAR	0.92	N/A	J	None	Datum is estimated, bias unknown; ion abundance ratio outside acceptance criteria
TS	TS-060206-1931	02/06/06	SW-846 8290	Octachlorodibenzo-p-dioxin	390	pg/g	LB	0.50 T	pg/g	B	None	Analyte detected in associated blank; sample concentration greater than five times the blank concentration
WS	WS-060206-1932	02/06/06	SW-846 6010B	Zinc	521	mg/kg	LB	0.2 T	mg/kg	B	None	Analyte detected in associated blank; sample concentration greater than five times the blank concentration
WS	WS-060206-1932	02/06/06	SW-846 8081A	p,p'-DDD	4.2 TD	µg/kg	CONF	97.1	%	J	None	Datum is estimated, bias unknown; %D between primary and secondary GC columns outside acceptance criterion
WS	WS-060206-1932	02/06/06	SW-846 8082	2,2',3,4,5'-Pentachlorobiphenyl	3.9 TD	µg/kg	CONF	604.2	%	J	None	Datum is estimated, bias unknown; %D between primary and secondary GC columns outside acceptance criterion
WS	WS-060206-1932	02/06/06	SW-846 8082	2,2',5-Trichlorobiphenyl	12 D	µg/kg	CONF	85.8	%	J	None	Datum is estimated, bias unknown; %D between primary and secondary GC columns outside acceptance criterion
WS	WS-060206-1932	02/06/06	SW-846 8082	2,3-Dichlorobiphenyl	2.1 TD	µg/kg	CONF	188.9	%	J	None	Datum is estimated, bias unknown; %D between primary and secondary GC columns outside acceptance criterion
WS	WS-060206-1932	02/06/06	SW-846 8270C	Benzo(b)fluoranthene	90 T	µg/kg	MS	45	%	J	Low	Datum is estimated, possible low bias; MS recovery outside acceptance criteria
WS	WS-060206-1932	02/06/06	SW-846 8270C	Fluorene	<1100	µg/kg	MS	43	%	UJ	Low	Possible false negative; MS recovery outside acceptance criteria
WS	WS-060206-1932	02/06/06	SW-846 8270C	Hexachloroethane	<1100	µg/kg	MS	37	%	UJ	Low	Possible false negative; MS recovery outside acceptance criteria
WS	WS-060206-1932	02/06/06	SW-846 8290	1,2,3,4,6,7,8-Heptachlorodibenzofuran	5.9 T	pg/g	IAR LB	1.24 0.14 T	N/A pg/g	JB	None	Datum is estimated, bias unknown; ion abundance ratio outside acceptance criteria. Analyte detected in associated blank; sample concentration greater than five times the blank concentration

TABLE 1
DATA QUALIFIERS SUMMARY TABLE
DEMONSTRATION TESTING AND FULL-SCALE OPERATION OF THE BIOGENESIS SEDIMENT DECONTAMINATION PROCESS, KEASBEY, NEW JERSEY
(Page69 of 188)

Location Identification	Sample Identification	Sample Date	Analysis	Analyte	Sample Result	Sample Units	QC Type	QC Result	QC Units	Qualifier	Bias	Comment
WS	WS-060206-1932	02/06/06	SW-846 8290	1,2,3,6,7,8-Hexachlorodibenzofuran	0.35 T	pg/g	IAR	2.25	N/A	J	None	Datum is estimated, bias unknown; ion abundance ratio outside acceptance criteria
WS	WS-060206-1932	02/06/06	SW-846 8290	1,2,3,7,8,9-Hexachlorodibenzo-p-Dioxin	0.98 T	pg/g	IAR	0.89	N/A	J	None	Datum is estimated, bias unknown; ion abundance ratio outside acceptance criteria
WS	WS-060206-1932	02/06/06	SW-846 8290	2,3,7,8-Tetrachlorodibenzo-p-dioxin	0.99 T	pg/g	IAR	0.52	N/A	J	None	Datum is estimated, bias unknown; ion abundance ratio outside acceptance criteria
WS	WS-060206-1932	02/06/06	SW-846 8290	Octachlorodibenzo-p-dioxin	1300	pg/g	LB	0.50 T	pg/g	B	None	Analyte detected in associated blank; sample concentration greater than five times the blank concentration
RS	RS-070206-1630	02/07/06	SW-846 6010B	Zinc	208	mg/kg	LB	0.2 T	mg/kg	B	None	Analyte detected in associated blank; sample concentration greater than five times the blank concentration
RS	RS-070206-1630	02/07/06	SW-846 8082	2,2',3,4,5'-Pentachlorobiphenyl	2.1 TD	µg/kg	CONF	607.1	%	J	None	Datum is estimated, bias unknown; %D between primary and secondary GC columns outside acceptance criterion
RS	RS-070206-1630	02/07/06	SW-846 8082	2,2',4,5,5'-Pentachlorobiphenyl	3.8 TD	µg/kg	CONF	67	%	J	None	Datum is estimated, bias unknown; %D between primary and secondary GC columns outside acceptance criterion
RS	RS-070206-1630	02/07/06	SW-846 8082	2,2',5-Trichlorobiphenyl	7.3 D	µg/kg	CONF	244	%	J	None	Datum is estimated, bias unknown; %D between primary and secondary GC columns outside acceptance criterion
RS	RS-070206-1630	02/07/06	SW-846 8082	2,3-Dichlorobiphenyl	4 TD	µg/kg	CONF	80.1	%	J	None	Datum is estimated, bias unknown; %D between primary and secondary GC columns outside acceptance criterion
RS	RS-070206-1630	02/07/06	SW-846 8082	2,4,5-Trichlorobiphenyl	6.5 D	µg/kg	CONF	44.7	%	J	None	Datum is estimated, bias unknown; %D between primary and secondary GC columns outside acceptance criterion
RS	RS-070206-1630	02/07/06	SW-846 8082	2-Chlorobiphenyl	28 TD	µg/kg	CONF	518.2	%	J	None	Datum is estimated, bias unknown; %D between primary and secondary GC columns outside acceptance criterion
RS	RS-070206-1630	02/07/06	SW-846 8290	1,2,3,4,7,8-Hexachlorodibenzofuran	5.1 T	pg/g	IAR	0.88	N/A	J	None	Datum is estimated, bias unknown; ion abundance ratio outside acceptance criteria
RS	RS-070206-1630	02/07/06	SW-846 8290	1,2,3,6,7,8-Hexachlorodibenzofuran	1.9 T	pg/g	IAR	0.82	N/A	J	None	Datum is estimated, bias unknown; ion abundance ratio outside acceptance criteria
RS	RS-070206-1630	02/07/06	SW-846 8290	1,2,3,7,8-Pentachlorodibenzofuran	2.3 T	pg/g	IAR	2.06	N/A	J	None	Datum is estimated, bias unknown; ion abundance ratio outside acceptance criteria
RS	RS-070206-1630	02/07/06	SW-846 8290	2,3,4,7,8-Pentachlorodibenzofuran	4.1 T	pg/g	IAR	1.21	N/A	J	None	Datum is estimated, bias unknown; ion abundance ratio outside acceptance criteria
RS	RS-070206-1630	02/07/06	SW-846 8290	2,3,7,8-Tetrachlorodibenzofuran	9	pg/g	IAR	0.6	N/A	J	None	Datum is estimated, bias unknown; ion abundance ratio outside acceptance criteria

TABLE 1
DATA QUALIFIERS SUMMARY TABLE
DEMONSTRATION TESTING AND FULL-SCALE OPERATION OF THE BIOGENESIS SEDIMENT DECONTAMINATION PROCESS, KEASBEY, NEW JERSEY
(Page70 of 188)

Location Identification	Sample Identification	Sample Date	Analysis	Analyte	Sample Result	Sample Units	QC Type	QC Result	QC Units	Qualifier	Bias	Comment
RS	RS-070206-1630	02/07/06	SW-846 8290	Octachlorodibenzo-p-dioxin	9000	pg/g	LB	0 71 T	pg/g	B	None	Analyte detected in associated blank; sample concentration greater than five times the blank concentration
RS	RS-070206-1630	02/07/06	SW-846 8290	Octachlorodibenzofuran	32 T	pg/g	IAR LB	0 75 0 25 T	N/A pg/g	JB	None	Datum is estimated, bias unknown; ion abundance ratio outside acceptance criteria Analyte detected in associated blank; sample concentration greater than five times the blank concentration
SP	SP-070206-1445	02/07/06	SW-846 6010B	Zinc	348	mg/kg	LB	0 2 T	mg/kg	B	None	Analyte detected in associated blank; sample concentration greater than five times the blank concentration
SP	SP-070206-1445	02/07/06	SW-846 8081A	Aldrin	6 6 TD	µg/kg	CONF	183 6	%	J	None	Datum is estimated, bias unknown; %D between primary and secondary GC columns outside acceptance criterion
SP	SP-070206-1445	02/07/06	SW-846 8081A	Alpha-Chlordane	11 TD	µg/kg	CONF	1000	%	J	None	Datum is estimated, bias unknown; %D between primary and secondary GC columns outside acceptance criterion
SP	SP-070206-1445	02/07/06	SW-846 8081A	Dieldrin	18 TD	µg/kg	CONF	1000	%	J	None	Datum is estimated, bias unknown; %D between primary and secondary GC columns outside acceptance criterion
SP	SP-070206-1445	02/07/06	SW-846 8081A	Endrin	4 9 TD	µg/kg	CONF	517 4	%	J	None	Datum is estimated, bias unknown; %D between primary and secondary GC columns outside acceptance criterion
SP	SP-070206-1445	02/07/06	SW-846 8081A	p,p'-DDT	81 D	µg/kg	CONF	331 6	%	J	None	Datum is estimated, bias unknown; %D between primary and secondary GC columns outside acceptance criterion
SP	SP-070206-1445	02/07/06	SW-846 8082	2,2',3,3',4,4',5-Heptachlorobiphenyl	6 1 TD	µg/kg	CONF	44 5	%	J	None	Datum is estimated, bias unknown; %D between primary and secondary GC columns outside acceptance criterion
SP	SP-070206-1445	02/07/06	SW-846 8082	2,2',3,4,4',5,5'-Heptachlorobiphenyl	10 TD	µg/kg	CONF	49 2	%	J	None	Datum is estimated, bias unknown; %D between primary and secondary GC columns outside acceptance criterion
SP	SP-070206-1445	02/07/06	SW-846 8082	2,2',3,4,5'-Pentachlorobiphenyl	14 TD	µg/kg	CONF	1000	%	J	None	Datum is estimated, bias unknown; %D between primary and secondary GC columns outside acceptance criterion
SP	SP-070206-1445	02/07/06	SW-846 8082	2,3-Dichlorobiphenyl	6 4 TD	µg/kg	CONF	189 2	%	J	None	Datum is estimated, bias unknown; %D between primary and secondary GC columns outside acceptance criterion
SP	SP-070206-1445	02/07/06	SW-846 8082	2-Chlorobiphenyl	88 TD	µg/kg	CONF	509 2	%	J	None	Datum is estimated, bias unknown; %D between primary and secondary GC columns outside acceptance criterion
SP	SP-070206-1445	02/07/06	SW-846 8290	1,2,3,4,7,8-Hexachlorodibenzo-p-dioxin	5 2 T	pg/g	IAR	0 93	N/A	J	None	Datum is estimated, bias unknown; ion abundance ratio outside acceptance criteria
SP	SP-070206-1445	02/07/06	SW-846 8290	1,2,3,7,8-Pentachlorodibenzofuran	15	pg/g	IAR	1 9	N/A	J	None	Datum is estimated, bias unknown; ion abundance ratio outside acceptance criteria
SP	SP-070206-1445	02/07/06	SW-846 8290	2,3,7,8-Tetrachlorodibenzofuran	21	pg/g	IAR	0 9	N/A	J	None	Datum is estimated, bias unknown; ion abundance ratio outside acceptance criteria

TABLE 1
DATA QUALIFIERS SUMMARY TABLE
DEMONSTRATION TESTING AND FULL-SCALE OPERATION OF THE BIOGENESIS SEDIMENT DECONTAMINATION PROCESS, KEASBEY, NEW JERSEY
(Page71 of 188)

Location Identification	Sample Identification	Sample Date	Analysis	Analyte	Sample Result	Sample Units	QC Type	QC Result	QC Units	Qualifier	Bias	Comment
SP	SP-070206-1445	02/07/06	SW-846 8290	Octachlorodibenzo-p-dioxin	7200	pg/g	LB	0.71 T	pg/g	B	None	Analyte detected in associated blank; sample concentration greater than five times the blank concentration
SP	SP-070206-1445	02/07/06	SW-846 8290	Octachlorodibenzofuran	650	pg/g	LB	0.25 T	pg/g	B	None	Analyte detected in associated blank; sample concentration greater than five times the blank concentration
TS	TS-070206-1631	02/07/06	SW-846 6010B	Zinc	137	mg/kg	LB	0.2 T	mg/kg	B	None	Analyte detected in associated blank; sample concentration greater than five times the blank concentration
TS	TS-070206-1631	02/07/06	SW-846 8081A	Aldrin	3.6 TD	µg/kg	CONF	139.2	%	J	None	Datum is estimated, bias unknown; %D between primary and secondary GC columns outside acceptance criterion
TS	TS-070206-1631	02/07/06	SW-846 8081A	Alpha BHC (alpha Hexachlorocyclohexane)	1.5 TD	µg/kg	CONF	66	%	J	None	Datum is estimated, bias unknown; %D between primary and secondary GC columns outside acceptance criterion
TS	TS-070206-1631	02/07/06	SW-846 8081A	Alpha-Chlordane	4.9 TD	µg/kg	CONF	96.8	%	J	None	Datum is estimated, bias unknown; %D between primary and secondary GC columns outside acceptance criterion
TS	TS-070206-1631	02/07/06	SW-846 8081A	Dieldrin	2.2 TD	µg/kg	CONF	320.8	%	J	None	Datum is estimated, bias unknown; %D between primary and secondary GC columns outside acceptance criterion
TS	TS-070206-1631	02/07/06	SW-846 8081A	Endosulfan sulfate	2.7 TD	µg/kg	CONF	140.1	%	J	None	Datum is estimated, bias unknown; %D between primary and secondary GC columns outside acceptance criterion
TS	TS-070206-1631	02/07/06	SW-846 8081A	Gamma-Chlordane	1.6 TD	µg/kg	CONF	293.4	%	J	None	Datum is estimated, bias unknown; %D between primary and secondary GC columns outside acceptance criterion
TS	TS-070206-1631	02/07/06	SW-846 8081A	p,p'-DDT	12 D	µg/kg	CONF	96.8	%	J	None	Datum is estimated, bias unknown; %D between primary and secondary GC columns outside acceptance criterion
TS	TS-070206-1631	02/07/06	SW-846 8082	2,2',3,4,4',5,5'-Heptachlorobiphenyl	1.8 TD	µg/kg	CONF	53.3	%	J	None	Datum is estimated, bias unknown; %D between primary and secondary GC columns outside acceptance criterion
TS	TS-070206-1631	02/07/06	SW-846 8082	2,2',3,4,5'-Pentachlorobiphenyl	2.5 TD	µg/kg	CONF	707.2	%	J	None	Datum is estimated, bias unknown; %D between primary and secondary GC columns outside acceptance criterion
TS	TS-070206-1631	02/07/06	SW-846 8082	2,2',3,4,5,5'-Hexachlorobiphenyl	0.76 TD	µg/kg	CONF	87.6	%	J	None	Datum is estimated, bias unknown; %D between primary and secondary GC columns outside acceptance criterion
TS	TS-070206-1631	02/07/06	SW-846 8082	2,2',4,5,5'-Pentachlorobiphenyl	5 D	µg/kg	CONF	47.5	%	J	None	Datum is estimated, bias unknown; %D between primary and secondary GC columns outside acceptance criterion
TS	TS-070206-1631	02/07/06	SW-846 8290	1,2,3,4,6,7,8-Heptachlorodibenzofuran	3.8 T	pg/g	IAR	1.55	N/A	J	None	Datum is estimated, bias unknown; ion abundance ratio outside acceptance criteria
TS	TS-070206-1631	02/07/06	SW-846 8290	1,2,3,4,7,8-Hexachlorodibenzofuran	0.90 T	pg/g	IAR	1.99	N/A	J	None	Datum is estimated, bias unknown; ion abundance ratio outside acceptance criteria

TABLE 1
DATA QUALIFIERS SUMMARY TABLE
DEMONSTRATION TESTING AND FULL-SCALE OPERATION OF THE BIOGENESIS SEDIMENT DECONTAMINATION PROCESS, KEASBEY, NEW JERSEY
(Page72 of 188)

Location Identification	Sample Identification	Sample Date	Analysis	Analyte	Sample Result	Sample Units	QC Type	QC Result	QC Units	Qualifier	Bias	Comment
TS	TS-070206-1631	02/07/06	SW-846 8290	1,2,3,6,7,8-Hexachlorodibenzofuran	0.29 T	pg/g	IAR	1.85	N/A	J	None	Datum is estimated, bias unknown; ion abundance ratio outside acceptance criteria
TS	TS-070206-1631	02/07/06	SW-846 8290	1,2,3,7,8,9-Hexachlorodibenzo-p-Dioxin	0.75 T	pg/g	IAR	0.86	N/A	J	None	Datum is estimated, bias unknown; ion abundance ratio outside acceptance criteria
TS	TS-070206-1631	02/07/06	SW-846 8290	1,2,3,7,8-Pentachlorodibenzofuran	0.29 T	pg/g	IAR	0.79	N/A	J	None	Datum is estimated, bias unknown; ion abundance ratio outside acceptance criteria
TS	TS-070206-1631	02/07/06	SW-846 8290	2,3,7,8-Tetrachlorodibenzofuran	0.87 T	pg/g	IAR	1.03	N/A	J	None	Datum is estimated, bias unknown; ion abundance ratio outside acceptance criteria
TS	TS-070206-1631	02/07/06	SW-846 8290	Octachlorodibenzo-p-dioxin	520	pg/g	MS MSD LB	300 1.6 0.71 T	% % pg/g	JB	High	Datum is estimated, possible high bias; MS/MSD recoveries outside acceptance criteria Analyte detected in associated blank; sample concentration greater than five times blank concentration
TS	TS-070206-1631	02/07/06	SW-846 8290	Octachlorodibenzofuran	6.4 T	pg/g	LB	0.25 T	pg/g	B	None	Analyte detected in associated blank; sample concentration greater than five times the blank concentration
TS	TS-070206-1631 DRIED	02/07/06	Lloyd Kahn	Total organic carbon	23800	mg/kg	HT	21	days	H	None	Sample air dried for 16 days before submission to the laboratory; sample analyzed within holding time after submission to the laboratory
TS	TS-070206-1631 DRIED	02/07/06	SW-846 8082	2,2',3,3',4,4',5-Heptachlorobiphenyl	0.73 TD	µg/kg	CONF	47.2	%	J	None	Datum is estimated, bias unknown; %D between primary and secondary GC columns outside acceptance criterion
TS	TS-070206-1631 DRIED	02/07/06	SW-846 8082	2,2',3,4',5,5',6-Heptachlorobiphenyl	0.88 TD	µg/kg	CONF	58.2	%	J	None	Datum is estimated, bias unknown; %D between primary and secondary GC columns outside acceptance criterion
TS	TS-070206-1631 DRIED	02/07/06	SW-846 8082	2,2',3,4,4',5,5'-Heptachlorobiphenyl	1.2 TD	µg/kg	CONF	52.7	%	J	None	Datum is estimated, bias unknown; %D between primary and secondary GC columns outside acceptance criterion
TS	TS-070206-1631 DRIED	02/07/06	SW-846 8082	2,2',3,4,5'-Pentachlorobiphenyl	1.7 TD	µg/kg	CONF	730	%	J	None	Datum is estimated, bias unknown; %D between primary and secondary GC columns outside acceptance criterion
TS	TS-070206-1631 DRIED	02/07/06	SW-846 8082	2,2',3,4,5,5'-Hexachlorobiphenyl	0.55 TD	µg/kg	CONF	51.2	%	J	None	Datum is estimated, bias unknown; %D between primary and secondary GC columns outside acceptance criterion
TS	TS-070206-1631 DRIED	02/07/06	SW-846 8082	2,2',4,5,5'-Pentachlorobiphenyl	3.7 D	µg/kg	CONF	44	%	J	None	Datum is estimated, bias unknown; %D between primary and secondary GC columns outside acceptance criterion
TS	TS-070206-1631 DRIED	02/07/06	SW-846 8082	2,2',5,5'-Tetrachlorobiphenyl	7.6 D	µg/kg	CONF	49.1	%	J	None	Datum is estimated, bias unknown; %D between primary and secondary GC columns outside acceptance criterion
TS	TS-070206-1631 DRIED	02/07/06	SW-846 8082	2,2',5-Trichlorobiphenyl	5.2 D	µg/kg	CONF	515	%	J	None	Datum is estimated, bias unknown; %D between primary and secondary GC columns outside acceptance criterion
TS	TS-070206-1631 DRIED	02/07/06	SW-846 8270C	1,4-Dichlorobenzene	<2100 D	µg/kg	HT	20	days	H	None	Sample air dried for 16 days before submission to the laboratory; sample analyzed within holding time after submission to the laboratory
TS	TS-070206-1631 DRIED	02/07/06	SW-846 8270C	2,4,5-Trichlorophenol	<2100 D	µg/kg	HT	20	days	H	None	Sample air dried for 16 days before submission to the laboratory; sample analyzed within holding time after submission to the laboratory

TABLE 1
DATA QUALIFIERS SUMMARY TABLE
DEMONSTRATION TESTING AND FULL-SCALE OPERATION OF THE BIOGENESIS SEDIMENT DECONTAMINATION PROCESS, KEASBEY, NEW JERSEY
(Page73 of 188)

Location Identification	Sample Identification	Sample Date	Analysis	Analyte	Sample Result	Sample Units	QC Type	QC Result	QC Units	Qualifier	Bias	Comment
TS	TS-070206-1631 DRIED	02/07/06	SW-846 8270C	2,4,6-Trichlorophenol	<2100 D	µg/kg	HT	20	days	H	None	Sample air dried for 16 days before submission to the laboratory; sample analyzed within holding time after submission to the laboratory
TS	TS-070206-1631 DRIED	02/07/06	SW-846 8270C	2,4-Dinitrotoluene	<2100 D	µg/kg	HT	20	days	H	None	Sample air dried for 16 days before submission to the laboratory; sample analyzed within holding time after submission to the laboratory
TS	TS-070206-1631 DRIED	02/07/06	SW-846 8270C	Hexachlorobenzene	<2100 D	µg/kg	HT	20	days	H	None	Sample air dried for 16 days before submission to the laboratory; sample analyzed within holding time after submission to the laboratory
TS	TS-070206-1631 DRIED	02/07/06	SW-846 8270C	Hexachlorobutadiene	<2100 D	µg/kg	HT	20	days	H	None	Sample air dried for 16 days before submission to the laboratory; sample analyzed within holding time after submission to the laboratory
TS	TS-070206-1631 DRIED	02/07/06	SW-846 8270C	Hexachloroethane	<2100 D	µg/kg	HT	20	days	H	None	Sample air dried for 16 days before submission to the laboratory; sample analyzed within holding time after submission to the laboratory
TS	TS-070206-1631 DRIED	02/07/06	SW-846 8270C	Nitrobenzene	<2100 D	µg/kg	HT	20	days	H	None	Sample air dried for 16 days before submission to the laboratory; sample analyzed within holding time after submission to the laboratory
TS	TS-070206-1631 DRIED	02/07/06	SW-846 8270C	Pentachlorophenol	<10000 D	µg/kg	HT	20	days	H	None	Sample air dried for 16 days before submission to the laboratory; sample analyzed within holding time after submission to the laboratory
TS	TS-070206-1631 DRIED	02/07/06	SW-846 8290	1,2,3,4,6,7,8-Heptachlorodibenzofuran	31	pg/g	LB	0.43 T	pg/g	B	None	Analyte detected in associated blank; sample concentration greater than five times the blank concentration
TS	TS-070206-1631 DRIED	02/07/06	SW-846 8290	1,2,3,4,7,8,9-Heptachlorodibenzofuran	1.5 T	pg/g	LB	0.47 T	pg/g	UB	None	Analyte considered not detected, analyte detected in associated blank; sample concentration less than five times the blank concentration
TS	TS-070206-1631 DRIED	02/07/06	SW-846 8290	1,2,3,4,7,8-Hexachlorodibenzofuran	4.7 T	pg/g	LB	0.43 T	pg/g	B	None	Analyte detected in associated blank; sample concentration greater than five times the blank concentration
TS	TS-070206-1631 DRIED	02/07/06	SW-846 8290	1,2,3,6,7,8-Hexachlorodibenzofuran	1.3 T	pg/g	IAR LB	1.64 0.36 T	N/A pg/g	JUB	None	Datum is estimated, bias unknown; ion abundance ratio outside acceptance criteria. Analyte considered not detected, analyte detected in associated blank; sample concentration less than five times the blank concentration
TS	TS-070206-1631 DRIED	02/07/06	SW-846 8290	1,2,3,7,8,9-Hexachlorodibenzo-p-Dioxin	6.3 T	pg/g	IAR LB	0.93 0.49 T	N/A pg/g	JB	None	Datum is estimated, bias unknown; ion abundance ratio outside acceptance criteria. Analyte detected in associated blank; sample concentration greater than five times the blank concentration
TS	TS-070206-1631 DRIED	02/07/06	SW-846 8290	1,2,3,7,8-Pentachlorodibenzo-p-dioxin	0.73 T	pg/g	IAR	0.93	N/A	J	None	Datum is estimated, bias unknown; ion abundance ratio outside acceptance criteria
TS	TS-070206-1631 DRIED	02/07/06	SW-846 8290	1,2,3,7,8-Pentachlorodibenzofuran	1.3 T	pg/g	LB	0.39 T	pg/g	UB	None	Analyte considered not detected, analyte detected in associated blank; sample concentration less than five times the blank concentration
TS	TS-070206-1631 DRIED	02/07/06	SW-846 8290	2,3,4,6,7,8-Hexachlorodibenzofuran	1.1 T	pg/g	LB	0.38 T	pg/g	UB	None	Analyte considered not detected, analyte detected in associated blank; sample concentration less than five times the blank concentration
TS	TS-070206-1631 DRIED	02/07/06	SW-846 8290	2,3,4,7,8-Pentachlorodibenzofuran	2.2 T	pg/g	LB	0.26 T	pg/g	B	None	Analyte detected in associated blank; sample concentration greater than five times the blank concentration

TABLE 1
DATA QUALIFIERS SUMMARY TABLE
DEMONSTRATION TESTING AND FULL-SCALE OPERATION OF THE BIOGENESIS SEDIMENT DECONTAMINATION PROCESS, KEASBEY, NEW JERSEY
(Page74 of 188)

Location Identification	Sample Identification	Sample Date	Analysis	Analyte	Sample Result	Sample Units	QC Type	QC Result	QC Units	Qualifier	Bias	Comment	
TS	TS-070206-1631 DRIED	02/07/06	SW-846 8290	2,3,7,8-Tetrachlorodibenzofuran	2.5	pg/g	IAR	0.64	N/A	J	None	Datum is estimated, bias unknown; ion abundance ratio outside acceptance criteria	
TS	TS-070206-1631 DRIED	02/07/06	SW-846 8290	Octachlorodibenzo-p-dioxin	7500	pg/g	MS MSD RANGE LB	300 1.6 N/A 1.8 T	% % N/A pg/g	JB	High	Datum is estimated, possible high bias; MS/MSD recoveries outside acceptance criteria and sample concentration outside calibration range. Analyte detected in associated blank; sample concentration greater than five times blank concentration	
TS	TS-070206-1631 DRIED	02/07/06	SW-846 8290	Octachlorodibenzofuran	86	pg/g	LB	1.1 T	pg/g	B	None	Analyte detected in associated blank; sample concentration greater than five times the blank concentration	
WS	WS-070206-1632	02/07/06	SW-846 6010B	Zinc	340	mg/kg	LB	0.2 T	mg/kg	B	None	Analyte detected in associated blank; sample concentration greater than five times the blank concentration	
WS	WS-070206-1632	02/07/06	SW-846 8081A	Dieldrin	2.0	TD	µg/kg	CONF	473.5	%	J	None	Datum is estimated, bias unknown; %D between primary and secondary GC columns outside acceptance criterion
WS	WS-070206-1632	02/07/06	SW-846 8082	2,2',3,4,5'-Pentachlorobiphenyl	3.8	TD	µg/kg	CONF	564.2	%	J	None	Datum is estimated, bias unknown; %D between primary and secondary GC columns outside acceptance criterion
WS	WS-070206-1632	02/07/06	SW-846 8082	2,3-Dichlorobiphenyl	2.1	TD	µg/kg	CONF	180.7	%	J	None	Datum is estimated, bias unknown; %D between primary and secondary GC columns outside acceptance criterion
WS	WS-070206-1632	02/07/06	SW-846 8082	2,4,5-Trichlorobiphenyl	11	D	µg/kg	CONF	46	%	J	None	Datum is estimated, bias unknown; %D between primary and secondary GC columns outside acceptance criterion
WS	WS-070206-1632	02/07/06	SW-846 8082	2-Chlorobiphenyl	19	TD	µg/kg	CONF	864.3	%	J	None	Datum is estimated, bias unknown; %D between primary and secondary GC columns outside acceptance criterion
WS	WS-070206-1632	02/07/06	SW-846 8270C	Hexachlorobutadiene	<1100	µg/kg	IS	>200		UJ	Low	Possible false negative; IS area recovery outside acceptance criteria	
WS	WS-070206-1632	02/07/06	SW-846 8270C	Naphthalene	<1100	µg/kg	IS	>200		UJ	Low	Possible false negative; IS area recovery outside acceptance criteria	
WS	WS-070206-1632	02/07/06	SW-846 8270C	Nitrobenzene	<1100	µg/kg	IS	>200		UJ	Low	Possible false negative; IS area recovery outside acceptance criteria	
WS	WS-070206-1632	02/07/06	SW-846 8290	2,3,7,8-Tetrachlorodibenzofuran	0.58	T	pg/g	IAR	0.53	N/A	J	None	Datum is estimated, bias unknown; ion abundance ratio outside acceptance criteria
WS	WS-070206-1632	02/07/06	SW-846 8290	Octachlorodibenzo-p-dioxin	1800	pg/g	LB	0.71 T	pg/g	B	None	Analyte detected in associated blank; sample concentration greater than five times the blank concentration	
WS	WS-070206-1632	02/07/06	SW-846 8290	Octachlorodibenzofuran	15	T	pg/g	LB	0.25 T	pg/g	B	None	Analyte detected in associated blank; sample concentration greater than five times the blank concentration

TABLE 1
DATA QUALIFIERS SUMMARY TABLE
DEMONSTRATION TESTING AND FULL-SCALE OPERATION OF THE BIOGENESIS SEDIMENT DECONTAMINATION PROCESS, KEASBEY, NEW JERSEY
 (Page75 of 188)

Location Identification	Sample Identification	Sample Date	Analysis	Analyte	Sample Result	Sample Units	QC Type	QC Result	QC Units	Qualifier	Bias	Comment
RS	RS-080206-1700	02/08/06	SW-846 6010B	Zinc	174	mg/kg	LB	0 30 T	mg/kg	B	None	Analyte detected in associated blank; sample concentration greater than five times the blank concentration
RS	RS-080206-1700	02/08/06	SW-846 8081A	Aldrin	1 7 TD	µg/kg	CONF	99 3	%	J	None	Datum is estimated, bias unknown; %D between primary and secondary GC columns outside acceptance criterion
RS	RS-080206-1700	02/08/06	SW-846 8081A	p,p'-DDD	6 8 TD	µg/kg	CONF	45 8	%	J	None	Datum is estimated, bias unknown; %D between primary and secondary GC columns outside acceptance criterion
RS	RS-080206-1700	02/08/06	SW-846 8082	2,2',3,3',4,4',5,5',6-Nonachlorobiphenyl	0 83 TD	µg/kg	CONF	824 3	%	J	None	Datum is estimated, bias unknown; %D between primary and secondary GC columns outside acceptance criterion
RS	RS-080206-1700	02/08/06	SW-846 8082	2,2',3,3',4,4',5-Heptachlorobiphenyl	1 1 TD	µg/kg	CONF	87 1	%	J	None	Datum is estimated, bias unknown; %D between primary and secondary GC columns outside acceptance criterion
RS	RS-080206-1700	02/08/06	SW-846 8082	2,2',3,4',5,5',6-Heptachlorobiphenyl	1 6 TD	µg/kg	CONF	40 3	%	J	None	Datum is estimated, bias unknown; %D between primary and secondary GC columns outside acceptance criterion
RS	RS-080206-1700	02/08/06	SW-846 8082	2,2',3,4,4',5'-Heptachlorobiphenyl	1 7 TD	µg/kg	CONF	97 5	%	J	None	Datum is estimated, bias unknown; %D between primary and secondary GC columns outside acceptance criterion
RS	RS-080206-1700	02/08/06	SW-846 8082	2,2',3,4,5'-Pentachlorobiphenyl	4 2 D	µg/kg	CONF	1000	%	J	None	Datum is estimated, bias unknown; %D between primary and secondary GC columns outside acceptance criterion
RS	RS-080206-1700	02/08/06	SW-846 8082	2,2',3,4,5,5'-Hexachlorobiphenyl	1 2 TD	µg/kg	CONF	60 4	%	J	None	Datum is estimated, bias unknown; %D between primary and secondary GC columns outside acceptance criterion
RS	RS-080206-1700	02/08/06	SW-846 8082	2,2',5-Trichlorobiphenyl	26 D	µg/kg	CONF	47 3	%	J	None	Datum is estimated, bias unknown; %D between primary and secondary GC columns outside acceptance criterion
RS	RS-080206-1700	02/08/06	SW-846 8082	2-Chlorobiphenyl	15 TD	µg/kg	CONF	140 7	%	J	None	Datum is estimated, bias unknown; %D between primary and secondary GC columns outside acceptance criterion
RS	RS-080206-1700	02/08/06	SW-846 8290	1,2,3,4,6,7,8-Heptachlorodibenzofuran	30	pg/g	LB	0 41 T	pg/g	B	None	Analyte detected in associated blank; sample concentration greater than five times the blank concentration
RS	RS-080206-1700	02/08/06	SW-846 8290	1,2,3,4,7,8,9-Heptachlorodibenzofuran	2 0 T	pg/g	IAR	0 83	N/A	J	None	Datum is estimated, bias unknown; ion abundance ratio outside acceptance criteria
RS	RS-080206-1700	02/08/06	SW-846 8290	1,2,3,4,7,8-Hexachlorodibenzo-p-dioxin	1 8 T	pg/g	IAR	1 56	N/A	J	None	Datum is estimated, bias unknown; ion abundance ratio outside acceptance criteria
RS	RS-080206-1700	02/08/06	SW-846 8290	1,2,3,7,8,9-Hexachlorodibenzo-p-Dioxin	5 9 T	pg/g	IAR	0 97	N/A	J	None	Datum is estimated, bias unknown; ion abundance ratio outside acceptance criteria
RS	RS-080206-1700	02/08/06	SW-846 8290	2,3,4,7,8-Pentachlorodibenzofuran	4 1 T	pg/g	IAR	1 22	N/A	J	None	Datum is estimated, bias unknown; ion abundance ratio outside acceptance criteria

TABLE 1
DATA QUALIFIERS SUMMARY TABLE
DEMONSTRATION TESTING AND FULL-SCALE OPERATION OF THE BIOGENESIS SEDIMENT DECONTAMINATION PROCESS, KEASBEY, NEW JERSEY
(Page 76 of 188)

Location Identification	Sample Identification	Sample Date	Analysis	Analyte	Sample Result	Sample Units	QC Type	QC Result	QC Units	Qualifier	Bias	Comment
RS	RS-080206-1700	02/08/06	SW-846 8290	Octachlorodibenzo-p-dioxin	8500	pg/g	LB	0 30 T	pg/g	B	None	Analyte detected in associated blank; sample concentration greater than five times the blank concentration
TS	TS-080206-1701	02/08/06	SW-846 6010B	Arsenic	34	mg/kg	SLD	16 1	%	J	None	Datum is estimated, bias unknown; serial dilution %D outside acceptance criterion
TS	TS-080206-1701	02/08/06	SW-846 6010B	Barium	100	mg/kg	SLD	12 6	%	J	None	Datum is estimated, bias unknown; serial dilution %D outside acceptance criterion
TS	TS-080206-1701	02/08/06	SW-846 6010B	Cadmium	1 3	mg/kg	MS MSD	73 73	%	J	Low	Datum is estimated, possible low bias; MS/MSD recoveries outside acceptance criteria
TS	TS-080206-1701	02/08/06	SW-846 6010B	Chromium, total	31 8	mg/kg	SLD	15 9	%	J	None	Datum is estimated, bias unknown; serial dilution %D outside acceptance criterion
TS	TS-080206-1701	02/08/06	SW-846 6010B	Lead	72	mg/kg	SLD	16 6	%	J	None	Datum is estimated, bias unknown; serial dilution %D outside acceptance criterion
TS	TS-080206-1701	02/08/06	SW-846 6010B	Nickel	28 1	mg/kg	SLD	17 4	%	J	None	Datum is estimated, bias unknown; serial dilution %D outside acceptance criterion
TS	TS-080206-1701	02/08/06	SW-846 6010B	Silver	3 7	mg/kg	MS MSD SLD	1 4 2 3 14 1	%	J	Low	Datum is estimated, possible low bias; MS/MSD recoveries and serial dilution %D outside acceptance criteria
TS	TS-080206-1701	02/08/06	SW-846 6010B	Zinc	148	mg/kg	SLD LB	19 7 0 30 T	% mg/kg	JB	None	Datum is estimated, bias unknown; serial dilution percent difference outside acceptance criterion Analyte detected in associated blank; sample concentration greater than five times the blank concentration
TS	TS-080206-1701	02/08/06	SW-846 8081A	Dieldrin	1 2 TD	µg/kg	CONF	123	%	J	None	Datum is estimated, bias unknown; %D between primary and secondary GC columns outside acceptance criterion
TS	TS-080206-1701	02/08/06	SW-846 8082	2,2',3,4,5'-Pentachlorobiphenyl	1 7 D	µg/kg	CONF	666 9	%	J	None	Datum is estimated, bias unknown; %D between primary and secondary GC columns outside acceptance criterion
TS	TS-080206-1701	02/08/06	SW-846 8082	2,2',5-Trichlorobiphenyl	5 9 D	µg/kg	CONF	353 8	%	J	None	Datum is estimated, bias unknown; %D between primary and secondary GC columns outside acceptance criterion
TS	TS-080206-1701	02/08/06	SW-846 8082	2-Chlorobiphenyl	13 D	µg/kg	CONF	212 6	%	J	None	Datum is estimated, bias unknown; %D between primary and secondary GC columns outside acceptance criterion
TS	TS-080206-1701	02/08/06	SW-846 8290	1,2,3,4,6,7,8-Heptachlorodibenzofuran	2 7 T	pg/g	IAR LB	1 28 0 41 T	N/A pg/g	JB	None	Datum is estimated, bias unknown; ion abundance ratio outside acceptance criteria Analyte detected in associated blank; sample concentration greater than five times the blank concentration
TS	TS-080206-1701	02/08/06	SW-846 8290	1,2,3,6,7,8-Hexachlorodibenzo-p-Dioxin	0 56 T	pg/g	IAR	1 04	N/A	J	None	Datum is estimated, bias unknown; ion abundance ratio outside acceptance criteria
TS	TS-080206-1701	02/08/06	SW-846 8290	1,2,3,6,7,8-Hexachlorodibenzofuran	0 34 T	pg/g	IAR	1 04	N/A	J	None	Datum is estimated, bias unknown; ion abundance ratio outside acceptance criteria

TABLE 1
DATA QUALIFIERS SUMMARY TABLE
DEMONSTRATION TESTING AND FULL-SCALE OPERATION OF THE BIOGENESIS SEDIMENT DECONTAMINATION PROCESS, KEASBEY, NEW JERSEY
(Page77 of 188)

Location Identification	Sample Identification	Sample Date	Analysis	Analyte	Sample Result	Sample Units	QC Type	QC Result	QC Units	Qualifier	Bias	Comment
TS	TS-080206-1701	02/08/06	SW-846 8290	1,2,3,7,8,9-Hexachlorodibenzo-p-Dioxin	0.43 T	pg/g	IAR	0.93	N/A	J	None	Datum is estimated, bias unknown; ion abundance ratio outside acceptance criteria
TS	TS-080206-1701	02/08/06	SW-846 8290	1,2,3,7,8-Pentachlorodibenzofuran	0.24 T	pg/g	IAR	0.95	N/A	J	None	Datum is estimated, bias unknown; ion abundance ratio outside acceptance criteria
TS	TS-080206-1701	02/08/06	SW-846 8290	2,3,4,7,8-Pentachlorodibenzofuran	0.85 T	pg/g	IAR	0.73	N/A	J	None	Datum is estimated, bias unknown; ion abundance ratio outside acceptance criteria
TS	TS-080206-1701	02/08/06	SW-846 8290	2,3,7,8-Tetrachlorodibenzofuran	1.5 T	pg/g	IAR	1.11	N/A	J	None	Datum is estimated, bias unknown; ion abundance ratio outside acceptance criteria
TS	TS-080206-1701	02/08/06	SW-846 8290	Octachlorodibenzo-p-dioxin	420	pg/g	LB	0.30 T	pg/g	B	None	Analyte detected in associated blank; sample concentration greater than five times the blank concentration
WS	WS-080206-1702	02/08/06	SW-846 6010B	Zinc	316	mg/kg	LB	0.30 T	mg/kg	B	None	Analyte detected in associated blank; sample concentration greater than five times the blank concentration
WS	WS-080206-1702	02/08/06	SW-846 8081A	p,p'-DDE	17 D	µg/kg	CONF	57	%	J	None	Datum is estimated, bias unknown; %D between primary and secondary GC columns outside acceptance criterion
WS	WS-080206-1702	02/08/06	SW-846 8082	2,2',3,4,4',5,5'-Heptachlorobiphenyl	2.4 TD	µg/kg	CONF	56.2	%	J	None	Datum is estimated, bias unknown; %D between primary and secondary GC columns outside acceptance criterion
WS	WS-080206-1702	02/08/06	SW-846 8082	2,2',3,4,5'-Pentachlorobiphenyl	3.9 D	µg/kg	MS CONF	43 620	%	J	Low	Datum is estimated; potentially biased low MS recovery and %D between primary and secondary GC columns outside acceptance criteria
WS	WS-080206-1702	02/08/06	SW-846 8082	2,2',5,5'-Tetrachlorobiphenyl	21 D	µg/kg	MS	20	%	J	Low	Datum is estimated, possible low bias; MS recovery outside acceptance criteria
WS	WS-080206-1702	02/08/06	SW-846 8082	2,2',5-Trichlorobiphenyl	12 D	µg/kg	MS CONF	42 94.1	%	J	Low	Datum is estimated; potentially biased low MS recovery and %D between primary and secondary GC columns outside acceptance criteria
WS	WS-080206-1702	02/08/06	SW-846 8082	2,3',4,4'-Tetrachlorobiphenyl	19 D	µg/kg	MS	27	%	J	Low	Datum is estimated, possible low bias; MS recovery outside acceptance criteria
WS	WS-080206-1702	02/08/06	SW-846 8082	2,3-Dichlorobiphenyl	2.5 TD	µg/kg	CONF	209.7	%	J	None	Datum is estimated, bias unknown; %D between primary and secondary GC columns outside acceptance criterion
WS	WS-080206-1702	02/08/06	SW-846 8082	2-Chlorobiphenyl	13 TD	µg/kg	CONF	62.2	%	J	None	Datum is estimated, bias unknown; %D between primary and secondary GC columns outside acceptance criterion
WS	WS-080206-1702	02/08/06	SW-846 8270C	Naphthalene	<1200	µg/kg	MS MSD	42 45	%	UJ	Low	Possible false negative; MS/MSD recoveries outside acceptance criteria
WS	WS-080206-1702	02/08/06	SW-846 8290	1,2,3,4,6,7,8-Heptachlorodibenzofuran	3.6 T	pg/g	IAR LB	1.46 0.41 T	N/A pg/g	JB	None	Datum is estimated, bias unknown; ion abundance ratio outside acceptance criteria. Analyte detected in associated blank; sample concentration greater than five times the blank concentration

TABLE 1
DATA QUALIFIERS SUMMARY TABLE
DEMONSTRATION TESTING AND FULL-SCALE OPERATION OF THE BIOGENESIS SEDIMENT DECONTAMINATION PROCESS, KEASBEY, NEW JERSEY
(Page78 of 188)

Location Identification	Sample Identification	Sample Date	Analysis	Analyte	Sample Result	Sample Units	QC Type	QC Result	QC Units	Qualifier	Bias	Comment
WS	WS-080206-1702	02/08/06	SW-846 8290	2,3,4,7,8-Pentachlorodibenzofuran	0.42 T	pg/g	IAR	0.39	N/A	J	None	Datum is estimated, bias unknown; ion abundance ratio outside acceptance criteria
WS	WS-080206-1702	02/08/06	SW-846 8290	2,3,7,8-Tetrachlorodibenzofuran	1.3 T	pg/g	IAR	1.07	N/A	J	None	Datum is estimated, bias unknown; ion abundance ratio outside acceptance criteria
WS	WS-080206-1702	02/08/06	SW-846 8290	Octachlorodibenzo-p-dioxin	1100	pg/g	LB	0.30 T	pg/g	B	None	Analyte detected in associated blank; sample concentration greater than five times the blank concentration
RS	RS-090206-2300	02/09/06	SW-846 6010B	Lead	214	mg/kg	MS SLD	128 10.1	%	J	High	Datum is estimated, possible high bias; MS recovery and serial dilution %D outside acceptance criteria
RS	RS-090206-2300	02/09/06	SW-846 6010B	Nickel	41.3	mg/kg	SLD	10.6	%	J	None	Datum is estimated, bias unknown; serial dilution %D outside acceptance criterion
RS	RS-090206-2300	02/09/06	SW-846 6010B	Zinc	338	mg/kg	SLD LB	14.5 0.3 T	% mg/kg	JB	None	Datum is estimated, bias unknown; serial dilution percent difference outside acceptance criterion. Analyte detected in associated blank; sample concentration greater than five times the blank concentration
RS	RS-090206-2300	02/09/06	SW-846 8081A	Aldrin	6.3 TD	µg/kg	CONF	186.2	%	J	None	Datum is estimated, bias unknown; %D between primary and secondary GC columns outside acceptance criterion
RS	RS-090206-2300	02/09/06	SW-846 8081A	Alpha-Chlordane	7.6 TD	µg/kg	CONF	1000	%	J	None	Datum is estimated, bias unknown; %D between primary and secondary GC columns outside acceptance criterion
RS	RS-090206-2300	02/09/06	SW-846 8081A	Dieldrin	13 TD	µg/kg	CONF	1000	%	J	None	Datum is estimated, bias unknown; %D between primary and secondary GC columns outside acceptance criterion
RS	RS-090206-2300	02/09/06	SW-846 8081A	Endrin	2.9 TD	µg/kg	CONF	674.3	%	J	None	Datum is estimated, bias unknown; %D between primary and secondary GC columns outside acceptance criterion
RS	RS-090206-2300	02/09/06	SW-846 8081A	Gamma-Chlordane	9.3 TD	µg/kg	CONF	62.5	%	J	None	Datum is estimated, bias unknown; %D between primary and secondary GC columns outside acceptance criterion
RS	RS-090206-2300	02/09/06	SW-846 8081A	p,p'-DDT	86 D	µg/kg	CONF	156.9	%	J	None	Datum is estimated, bias unknown; %D between primary and secondary GC columns outside acceptance criterion
RS	RS-090206-2300	02/09/06	SW-846 8082	2,2',3,4,4',5,5'-Heptachlorobiphenyl	9.7 D	µg/kg	CONF	71.7	%	J	None	Datum is estimated, bias unknown; %D between primary and secondary GC columns outside acceptance criterion
RS	RS-090206-2300	02/09/06	SW-846 8082	2,2',3,4,5'-Pentachlorobiphenyl	12 D	µg/kg	CONF	1000	%	J	None	Datum is estimated, bias unknown; %D between primary and secondary GC columns outside acceptance criterion
RS	RS-090206-2300	02/09/06	SW-846 8082	2,2',5,5'-Tetrachlorobiphenyl	37 D	µg/kg	CONF	49.6	%	J	None	Datum is estimated, bias unknown; %D between primary and secondary GC columns outside acceptance criterion
RS	RS-090206-2300	02/09/06	SW-846 8082	2-Chlorobiphenyl	23 TD	µg/kg	CONF	144.4	%	J	None	Datum is estimated, bias unknown; %D between primary and secondary GC columns outside acceptance criterion
RS	RS-090206-2300	02/09/06	SW-846 8290	1,2,3,7,8,9-Hexachlorodibenzofuran	2.1 T	pg/g	IAR	1.57	N/A	J	None	Datum is estimated, bias unknown; ion abundance ratio outside acceptance criteria

TABLE 1
DATA QUALIFIERS SUMMARY TABLE
DEMONSTRATION TESTING AND FULL-SCALE OPERATION OF THE BIOGENESIS SEDIMENT DECONTAMINATION PROCESS, KEASBEY, NEW JERSEY
(Page79 of 188)

Location Identification	Sample Identification	Sample Date	Analysis	Analyte	Sample Result	Sample Units	QC Type	QC Result	QC Units	Qualifier	Bias	Comment
RS	RS-090206-2300	02/09/06	SW-846 8290	1,2,3,7,8-Pentachlorodibenzo-p-dioxin	3 1 T	pg/g	IAR	2 38	N/A	J	None	Datum is estimated, bias unknown; ion abundance ratio outside acceptance criteria
RS	RS-090206-2300	02/09/06	SW-846 8290	1,2,3,7,8-Pentachlorodibenzofuran	11 T	pg/g	IAR	1 92	N/A	J	None	Datum is estimated, bias unknown; ion abundance ratio outside acceptance criteria
RS	RS-090206-2300	02/09/06	SW-846 8290	2,3,4,6,7,8-Hexachlorodibenzofuran	13 T	pg/g	IAR	1 45	N/A	J	None	Datum is estimated, bias unknown; ion abundance ratio outside acceptance criteria
RS	RS-090206-2300	02/09/06	SW-846 8290	2,3,7,8-Tetrachlorodibenzofuran	49	pg/g	IAR	0 64	N/A	J	None	Datum is estimated, bias unknown; ion abundance ratio outside acceptance criteria
RS	RS-090206-2300	02/09/06	SW-846 8290	Octachlorodibenzo-p-dioxin	5800	pg/g	LB	0 41 T	pg/g	B	None	Analyte detected in associated blank; sample concentration greater than five times the blank concentration
TS	TS-090206-2301	02/09/06	SW-846 6010B	Zinc	199	mg/kg	LB	0 3 T	mg/kg	B	None	Analyte detected in associated blank; sample concentration greater than five times the blank concentration
TS	TS-090206-2301	02/09/06	SW-846 8081A	Aldrin	4 5 TD	µg/kg	CONF	159 9	%	J	None	Datum is estimated, bias unknown; %D between primary and secondary GC columns outside acceptance criterion
TS	TS-090206-2301	02/09/06	SW-846 8081A	Alpha-Chlordane	9 5 TD	µg/kg	CONF	768	%	J	None	Datum is estimated, bias unknown; %D between primary and secondary GC columns outside acceptance criterion
TS	TS-090206-2301	02/09/06	SW-846 8081A	Dieldrin	8 3 TD	µg/kg	CONF	1000	%	J	None	Datum is estimated, bias unknown; %D between primary and secondary GC columns outside acceptance criterion
TS	TS-090206-2301	02/09/06	SW-846 8082	2,2',3,4,4',5,5'-Heptachlorobiphenyl	4 2 D	µg/kg	CONF	63	%	J	None	Datum is estimated, bias unknown; %D between primary and secondary GC columns outside acceptance criterion
TS	TS-090206-2301	02/09/06	SW-846 8082	2,2',3,4,5'-Pentachlorobiphenyl	5 D	µg/kg	CONF	1000	%	J	None	Datum is estimated, bias unknown; %D between primary and secondary GC columns outside acceptance criterion
TS	TS-090206-2301	02/09/06	SW-846 8082	2,2',5,5'-Tetrachlorobiphenyl	18 D	µg/kg	CONF	46 2	%	J	None	Datum is estimated, bias unknown; %D between primary and secondary GC columns outside acceptance criterion
TS	TS-090206-2301	02/09/06	SW-846 8082	2,2',5-Trichlorobiphenyl	17 D	µg/kg	CONF	41 3	%	J	None	Datum is estimated, bias unknown; %D between primary and secondary GC columns outside acceptance criterion
TS	TS-090206-2301	02/09/06	SW-846 8082	2-Chlorobiphenyl	0 93 TD	µg/kg	CONF	1000	%	J	None	Datum is estimated, bias unknown; %D between primary and secondary GC columns outside acceptance criterion
TS	TS-090206-2301	02/09/06	SW-846 8290	1,2,3,4,7,8,9-Heptachlorodibenzofuran	4 0 T	pg/g	IAR	1 31	N/A	J	None	Datum is estimated, bias unknown; ion abundance ratio outside acceptance criteria
TS	TS-090206-2301	02/09/06	SW-846 8290	1,2,3,4,7,8-Hexachlorodibenzo-p-dioxin	1 1 T	pg/g	IAR	0 98	N/A	J	None	Datum is estimated, bias unknown; ion abundance ratio outside acceptance criteria
TS	TS-090206-2301	02/09/06	SW-846 8290	1,2,3,6,7,8-Hexachlorodibenzofuran	4 3 T	pg/g	IAR	1 49	N/A	J	None	Datum is estimated, bias unknown; ion abundance ratio outside acceptance criteria

TABLE 1
DATA QUALIFIERS SUMMARY TABLE
DEMONSTRATION TESTING AND FULL-SCALE OPERATION OF THE BIOGENESIS SEDIMENT DECONTAMINATION PROCESS, KEASBEY, NEW JERSEY
(Page80 of 188)

Location Identification	Sample Identification	Sample Date	Analysis	Analyte	Sample Result	Sample Units	QC Type	QC Result	QC Units	Qualifier	Bias	Comment
TS	TS-090206-2301	02/09/06	SW-846 8290	2,3,7,8-Tetrachlorodibenzofuran	12	pg/g	IAR	0.64	N/A	J	None	Datum is estimated, bias unknown; ion abundance ratio outside acceptance criteria
TS	TS-090206-2301	02/09/06	SW-846 8290	Octachlorodibenzo-p-dioxin	1700	pg/g	LB	0.41 T	pg/g	B	None	Analyte detected in associated blank; sample concentration greater than five times the blank concentration
WS	WS-090206-2302	02/09/06	SW-846 6010B	Zinc	492	mg/kg	LB	0.3 T	mg/kg	B	None	Analyte detected in associated blank; sample concentration greater than five times the blank concentration
WS	WS-090206-2302	02/09/06	SW-846 8081A	Aldrin	7.8 TD	µg/kg	CONF	208.6	%	J	None	Datum is estimated, bias unknown; %D between primary and secondary GC columns outside acceptance criterion
WS	WS-090206-2302	02/09/06	SW-846 8081A	Alpha-Chlordane	12 TD	µg/kg	CONF	1000	%	J	None	Datum is estimated, bias unknown; %D between primary and secondary GC columns outside acceptance criterion
WS	WS-090206-2302	02/09/06	SW-846 8081A	beta Endosulfan	7.6 TD	µg/kg	CONF	335.9	%	J	None	Datum is estimated, bias unknown; %D between primary and secondary GC columns outside acceptance criterion
WS	WS-090206-2302	02/09/06	SW-846 8081A	Dieldrin	20 TD	µg/kg	CONF	1000	%	J	None	Datum is estimated, bias unknown; %D between primary and secondary GC columns outside acceptance criterion
WS	WS-090206-2302	02/09/06	SW-846 8081A	Endrin	5.6 TD	µg/kg	CONF	552.6	%	J	None	Datum is estimated, bias unknown; %D between primary and secondary GC columns outside acceptance criterion
WS	WS-090206-2302	02/09/06	SW-846 8081A	Gamma-Chlordane	13 TD	µg/kg	CONF	67.8	%	J	None	Datum is estimated, bias unknown; %D between primary and secondary GC columns outside acceptance criterion
WS	WS-090206-2302	02/09/06	SW-846 8081A	p,p'-DDT	58 D	µg/kg	CONF	284.9	%	J	None	Datum is estimated, bias unknown; %D between primary and secondary GC columns outside acceptance criterion
WS	WS-090206-2302	02/09/06	SW-846 8082	2,2',3,4,4',5,5'-Heptachlorobiphenyl	12 D	µg/kg	CONF	56.1	%	J	None	Datum is estimated, bias unknown; %D between primary and secondary GC columns outside acceptance criterion
WS	WS-090206-2302	02/09/06	SW-846 8082	2,2',3,4,5'-Pentachlorobiphenyl	15 D	µg/kg	CONF	1000	%	J	None	Datum is estimated, bias unknown; %D between primary and secondary GC columns outside acceptance criterion
WS	WS-090206-2302	02/09/06	SW-846 8082	2-Chlorobiphenyl	21 TD	µg/kg	CONF	191.1	%	J	None	Datum is estimated, bias unknown; %D between primary and secondary GC columns outside acceptance criterion
WS	WS-090206-2302	02/09/06	SW-846 8290	1,2,3,4,7,8-Hexachlorodibenzo-p-dioxin	2.3 T	pg/g	IAR	0.77	N/A	J	None	Datum is estimated, bias unknown; ion abundance ratio outside acceptance criteria
WS	WS-090206-2302	02/09/06	SW-846 8290	1,2,3,7,8,9-Hexachlorodibenzofuran	1.5 T	pg/g	IAR	1.52	N/A	J	None	Datum is estimated, bias unknown; ion abundance ratio outside acceptance criteria
WS	WS-090206-2302	02/09/06	SW-846 8290	2,3,4,7,8-Pentachlorodibenzofuran	8.1 T	pg/g	IAR	1.29	N/A	J	None	Datum is estimated, bias unknown; ion abundance ratio outside acceptance criteria

TABLE 1
DATA QUALIFIERS SUMMARY TABLE
DEMONSTRATION TESTING AND FULL-SCALE OPERATION OF THE BIOGENESIS SEDIMENT DECONTAMINATION PROCESS, KEASBEY, NEW JERSEY
(Page81 of 188)

Location Identification	Sample Identification	Sample Date	Analysis	Analyte	Sample Result	Sample Units	QC Type	QC Result	QC Units	Qualifier	Bias	Comment
WS	WS-090206-2302	02/09/06	SW-846 8290	Octachlorodibenzo-p-dioxin	6100	pg/g	LB	0 41 T	pg/g	B	None	Analyte detected in associated blank; sample concentration greater than five times the blank concentration
RS	RS-130206-1700	02/13/06	SW-846 6010B	Zinc	810	mg/kg	LB	0 23 T	mg/kg	B	None	Analyte detected in associated blank; sample concentration greater than five times the blank concentration
RS	RS-130206-1700	02/13/06	SW-846 7471A	Mercury	5 5	mg/kg	CVS	116	%	J	None	Datum is estimated, bias unknown; CVS %D outside acceptance criterion
RS	RS-130206-1700	02/13/06	SW-846 8082	2,2',3,4,4',5,5'-Heptachlorobiphenyl	16 D	µg/kg	CONF CVS	79 1 -27 8	%	J	None	Datum is estimated, bias unknown; CVS %D and %D between primary and secondary GC columns outside acceptance criteria
RS	RS-130206-1700	02/13/06	SW-846 8082	2,2',3,4,5'-Pentachlorobiphenyl	14 D	µg/kg	CONF	451	%	J	None	Datum is estimated, bias unknown; %D between primary and secondary GC columns outside acceptance criterion
RS	RS-130206-1700	02/13/06	SW-846 8290	1,2,3,4,7,8-Hexachlorodibenzo-p-dioxin	14 T	pg/g	CMC	3	s	J	None	Datum is estimated, bias unknown; peaks comax outside acceptance criterion
RS	RS-130206-1700	02/13/06	SW-846 8290	1,2,3,4,7,8-Hexachlorodibenzofuran	320	pg/g	PDE	N/A	N/A	J	None	Datum is estimated, bias unknown; interfering polychlorinated diphenyl ether peak present
RS	RS-130206-1700	02/13/06	SW-846 8290	1,2,3,7,8-Pentachlorodibenzo-p-dioxin	10 T	pg/g	IAR	2 49	N/A	J	None	Datum is estimated, bias unknown; ion abundance ratio outside acceptance criteria
RS	RS-130206-1700	02/13/06	SW-846 8290	2,3,4,6,7,8-Hexachlorodibenzofuran	39 T	pg/g	PDE	N/A	N/A	J	None	Datum is estimated, bias unknown; interfering polychlorinated diphenyl ether peak present
RS	RS-130206-1700	02/13/06	SW-846 8290	2,3,7,8-Tetrachlorodibenzofuran	95	pg/g	PDE	N/A	N/A	J	None	Datum is estimated, bias unknown; interfering polychlorinated diphenyl ether peak present
RS	RS-130206-1700	02/13/06	SW-846 8290	Octachlorodibenzofuran	1800	pg/g	PDE	N/A	N/A	J	None	Datum is estimated, bias unknown; interfering polychlorinated diphenyl ether peak present
RS	RS-130206-1700	02/13/06	SW-846 8081A	Endrin	6	µg/kg	CONF	542	%	J	None	Datum is estimated, bias unknown; %D between primary and secondary GC columns outside acceptance criterion
RS	RS-130206-1700	02/13/06	SW-846 8081A	Alpha-Chlordane	17	µg/kg	CONF	81 1	%	J	None	Datum is estimated, bias unknown; %D between primary and secondary GC columns outside acceptance criterion
RS	RS-130206-1700	02/13/06	SW-846 8081A	Gamma-Chlordane	14	µg/kg	CONF	94 6	%	J	None	Datum is estimated, bias unknown; %D between primary and secondary GC columns outside acceptance criterion
RS	RS-130206-1700	02/13/06	SW-846 8081A	Aldrin	7 8	µg/kg	CONF	201	%	J	None	Datum is estimated, bias unknown; %D between primary and secondary GC columns outside acceptance criterion
RS	RS-130206-1700	02/13/06	SW-846 8081A	p,p'-DDD	47	µg/kg	CONF	321	%	J	None	Datum is estimated, bias unknown; %D between primary and secondary GC columns outside acceptance criterion
RS	RS-130206-1700	02/13/06	SW-846 8081A	p,p'-DDT	17	µg/kg	CONF	143	%	J	None	Datum is estimated, bias unknown; %D between primary and secondary GC columns outside acceptance criterion
TS	TS-130206-1701	02/13/06	SW-846 6010B	Arsenic	10 8	mg/kg	SLD	10 1	%	J	None	Datum is estimated, bias unknown; serial dilution %D outside acceptance criterion

TABLE 1
DATA QUALIFIERS SUMMARY TABLE
DEMONSTRATION TESTING AND FULL-SCALE OPERATION OF THE BIOGENESIS SEDIMENT DECONTAMINATION PROCESS, KEASBEY, NEW JERSEY
(Page82 of 188)

Location Identification	Sample Identification	Sample Date	Analysis	Analyte	Sample Result	Sample Units	QC Type	QC Result	QC Units	Qualifier	Bias	Comment
TS	TS-130206-1701	02/13/06	SW-846 6010B	Silver	1 3	mg/kg	SLD	19 1	%	J	None	Datum is estimated, bias unknown; serial dilution %D outside acceptance criterion
TS	TS-130206-1701	02/13/06	SW-846 6010B	Zinc	200	mg/kg	SLD LB	13 8 0 23 T	% mg/kg	JB	None	Datum is estimated, bias unknown; serial dilution percent difference outside acceptance criterion Analyte detected in associated blank; sample concentration greater than five times the blank concentration
TS	TS-130206-1701	02/13/06	SW-846 7471A	Mercury	2 1	mg/kg	CVS	116	%	J	None	Datum is estimated, bias unknown; CVS %D outside acceptance criterion
TS	TS-130206-1701	02/13/06	SW-846 8082	2,2',3,4,4',5,5'-Heptachlorobiphenyl	8 D	µg/kg	CONF CVS	55 8 -27 8	%	J	None	Datum is estimated, bias unknown; CVS %D and %D between primary and secondary GC columns outside acceptance criteria
TS	TS-130206-1701	02/13/06	SW-846 8082	2,2',3,4,5'-Pentachlorobiphenyl	7 6 D	µg/kg	CONF	1000	%	J	None	Datum is estimated, bias unknown; %D between primary and secondary GC columns outside acceptance criterion
TS	TS-130206-1701	02/13/06	SW-846 8082	2,2',3,5,5',6-Hexachlorobiphenyl	1 2 TD	µg/kg	CONF	860	%	J	None	Datum is estimated, bias unknown; %D between primary and secondary GC columns outside acceptance criterion
TS	TS-130206-1701	02/13/06	SW-846 8082	2,3-Dichlorobiphenyl	4 5 D	µg/kg	CONF	69 4	%	J	None	Datum is estimated, bias unknown; %D between primary and secondary GC columns outside acceptance criterion
TS	TS-130206-1701	02/13/06	SW-846 8270C	Benzo(b)fluoranthene	1300 TD	µg/kg	MSD	44	%	J	Low	Datum is estimated, possible low bias; MSD recovery outside acceptance criteria
TS	TS-130206-1701	02/13/06	SW-846 8270C	Fluoranthene	3000 TD	µg/kg	MS MSD	178 161	%	J	High	Datum is estimated, possible high bias; MS/MSD recoveries outside acceptance criteria
TS	TS-130206-1701	02/13/06	SW-846 8290	1,2,3,4,7,8-Hexachlorodibenzo-p-dioxin	1 0 T	pg/g	IAR	1 6	N/A	J	None	Datum is estimated, bias unknown; ion abundance ratio outside acceptance criteria
TS	TS-130206-1701	02/13/06	SW-846 8290	1,2,3,4,7,8-Hexachlorodibenzofuran	25	pg/g	PDE	N/A	N/A	J	None	Datum is estimated, bias unknown; interfering polychlorinated diphenyl ether peak present
TS	TS-130206-1701	02/13/06	SW-846 8290	1,2,3,7,8,9-Hexachlorodibenzo-p-Dioxin	3 7 T	pg/g	IAR	1 03	N/A	J	None	Datum is estimated, bias unknown; ion abundance ratio outside acceptance criteria
TS	TS-130206-1701	02/13/06	SW-846 8290	1,2,3,7,8,9-Hexachlorodibenzofuran	1 2 T	pg/g	IAR CMC	0 93 5	N/A s	J	None	Datum is estimated, bias unknown; ion abundance ratio and comax peaks outside acceptance criteria
TS	TS-130206-1701	02/13/06	SW-846 8290	2,3,4,7,8-Pentachlorodibenzofuran	7 9 T	pg/g	IAR	1 91	N/A	J	None	Datum is estimated, bias unknown; ion abundance ratio outside acceptance criteria
TS	TS-130206-1701	02/13/06	SW-846 8081A	Dieldrin	7 1	µg/kg	CONF	1000	%	J	None	Datum is estimated, bias unknown; %D between primary and secondary GC columns outside acceptance criterion
TS	TS-130206-1701	02/13/06	SW-846 8081A	Endrin	9 6	µg/kg	CONF	101	%	J	None	Datum is estimated, bias unknown; %D between primary and secondary GC columns outside acceptance criterion
TS	TS-130206-1701	02/13/06	SW-846 8081A	Alpha-Chlordane	12	µg/kg	CONF	320	%	J	None	Datum is estimated, bias unknown; %D between primary and secondary GC columns outside acceptance criterion
TS	TS-130206-1701	02/13/06	SW-846 8081A	Aldrin	5 5	µg/kg	CONF	235	%	J	None	Datum is estimated, bias unknown; %D between primary and secondary GC columns outside acceptance criterion

TABLE 1
DATA QUALIFIERS SUMMARY TABLE
DEMONSTRATION TESTING AND FULL-SCALE OPERATION OF THE BIOGENESIS SEDIMENT DECONTAMINATION PROCESS, KEASBEY, NEW JERSEY
(Page83 of 188)

Location Identification	Sample Identification	Sample Date	Analysis	Analyte	Sample Result	Sample Units	QC Type	QC Result	QC Units	Qualifier	Bias	Comment
TS	TS-130206-1701	02/13/06	SW-846 8081A	p,p'-DDD	110	µg/kg	CONF	324	%	J	None	Datum is estimated, bias unknown; %D between primary and secondary GC columns outside acceptance criterion
TS	TS-130206-1701	02/13/06	SW-846 8081A	p,p'-DDT	110	µg/kg	CONF	46.8	%	J	None	Datum is estimated, bias unknown; %D between primary and secondary GC columns outside acceptance criterion
WS	WS-130206-1702	02/13/06	SW-846 6010B	Zinc	733	mg/kg	LB	0.23 T	mg/kg	B	None	Analyte detected in associated blank; sample concentration greater than five times the blank concentration
WS	WS-130206-1702	02/13/06	SW-846 7471A	Mercury	18.9	mg/kg	CVS	116	%	J	None	Datum is estimated, bias unknown; CVS %D outside acceptance criterion
WS	WS-130206-1702	02/13/06	SW-846 8082	2,2',3,4,4',5,5'-Heptachlorobiphenyl	22 D	µg/kg	CONF CVS	44.9 -27.8	%	J	None	Datum is estimated, bias unknown; CVS %D and %D between primary and secondary GC columns outside acceptance criteria
WS	WS-130206-1702	02/13/06	SW-846 8082	2,2',3,4,5'-Pentachlorobiphenyl	22 D	µg/kg	CONF	1000	%	J	None	Datum is estimated, bias unknown; %D between primary and secondary GC columns outside acceptance criterion
WS	WS-130206-1702	02/13/06	SW-846 8082	2,2',5,5'-Tetrachlorobiphenyl	72 D	µg/kg	CONF	44.3	%	J	None	Datum is estimated, bias unknown; %D between primary and secondary GC columns outside acceptance criterion
WS	WS-130206-1702	02/13/06	SW-846 8082	2,3-Dichlorobiphenyl	16 D	µg/kg	CONF	142	%	J	None	Datum is estimated, bias unknown; %D between primary and secondary GC columns outside acceptance criterion
WS	WS-130206-1702	02/13/06	SW-846 8082	2-Chlorobiphenyl	5.9 TD	µg/kg	CONF	1000	%	J	None	Datum is estimated, bias unknown; %D between primary and secondary GC columns outside acceptance criterion
WS	WS-130206-1702	02/13/06	SW-846 8290	1,2,3,4,7,8-Hexachlorodibenzo-p-dioxin	2.5 T	pg/g	IAR	1.82	N/A	J	None	Datum is estimated, bias unknown; ion abundance ratio outside acceptance criteria
WS	WS-130206-1702	02/13/06	SW-846 8290	1,2,3,6,7,8-Hexachlorodibenzofuran	12 T	pg/g	IAR	1.5	N/A	J	None	Datum is estimated, bias unknown; ion abundance ratio outside acceptance criteria
WS	WS-130206-1702	02/13/06	SW-846 8290	1,2,3,7,8-Pentachlorodibenzo-p-dioxin	2.3 T	pg/g	IAR	2.05	N/A	J	None	Datum is estimated, bias unknown; ion abundance ratio outside acceptance criteria
WS	WS-130206-1702	02/13/06	SW-846 8290	2,3,4,6,7,8-Hexachlorodibenzofuran	8.1 T	pg/g	IAR	1.01	N/A	J	None	Datum is estimated, bias unknown; ion abundance ratio outside acceptance criteria
WS	WS-130206-1702	02/13/06	SW-846 8290	2,3,7,8-Tetrachlorodibenzofuran	10	pg/g	IAR	0.27	N/A	J	None	Datum is estimated, bias unknown; ion abundance ratio outside acceptance criteria
WS	WS-130206-1702	02/13/06	SW-846 8081A	Dieldrin	23	µg/kg	CONF	788	%	J	None	Datum is estimated, bias unknown; %D between primary and secondary GC columns outside acceptance criterion
WS	WS-130206-1702	02/13/06	SW-846 8081A	Alpha-Chlordane	6.8	µg/kg	CONF	1000	%	J	None	Datum is estimated, bias unknown; %D between primary and secondary GC columns outside acceptance criterion
WS	WS-130206-1702	02/13/06	SW-846 8081A	Gamma-Chlordane	8.7	µg/kg	CONF	81.4	%	J	None	Datum is estimated, bias unknown; %D between primary and secondary GC columns outside acceptance criterion

TABLE 1
DATA QUALIFIERS SUMMARY TABLE
DEMONSTRATION TESTING AND FULL-SCALE OPERATION OF THE BIOGENESIS SEDIMENT DECONTAMINATION PROCESS, KEASBEY, NEW JERSEY
(Page84 of 188)

Location Identification	Sample Identification	Sample Date	Analysis	Analyte	Sample Result	Sample Units	QC Type	QC Result	QC Units	Qualifier	Bias	Comment
WS	WS-130206-1702	02/13/06	SW-846 8081A	Aldrin	6.3	µg/kg	CONF	196	%	J	None	Datum is estimated, bias unknown; %D between primary and secondary GC columns outside acceptance criterion
WS	WS-130206-1702	02/13/06	SW-846 8081A	p,p'-DDD	150	µg/kg	CONF	514	%	J	None	Datum is estimated, bias unknown; %D between primary and secondary GC columns outside acceptance criterion
WS	WS-130206-1702	02/13/06	SW-846 8081A	p,p'-DDT	71	µg/kg	CONF	162	%	J	None	Datum is estimated, bias unknown; %D between primary and secondary GC columns outside acceptance criterion
RS	RS-140206-1330	02/14/06	SW-846 6010B	Selenium	2.9	mg/kg	SLD	36.6	%	J	None	Datum is estimated, bias unknown; serial dilution %D outside acceptance criterion
RS	RS-140206-1330	02/14/06	SW-846 6010B	Silver	5	mg/kg	LB	0.030 T	mg/kg	B	None	Analyte detected in associated blank; sample concentration greater than five times the blank concentration
RS	RS-140206-1330	02/14/06	SW-846 6010B	Zinc	493	mg/kg	SLD LB	10.7 0.40 T	% mg/kg	JB	None	Datum is estimated, bias unknown; serial dilution percent difference outside acceptance criterion. Analyte detected in associated blank; sample concentration greater than five times the blank concentration
RS	RS-140206-1330	02/14/06	SW-846 7471A	Mercury	8.3	mg/kg	CVS	116	%	J	None	Datum is estimated, bias unknown; CVS %D outside acceptance criterion
RS	RS-140206-1330	02/14/06	SW-846 8082	2,2',3,3',4,4',5,5',6-Nonachlorobiphenyl	9.2 D	µg/kg	CVS	-15.7	%	J	None	Datum is estimated, bias unknown; CVS %D outside acceptance criterion
RS	RS-140206-1330	02/14/06	SW-846 8082	2,2',3,4,4',5,5'-Heptachlorobiphenyl	16 D	µg/kg	CONF CVS	97 -27.8	%	J	None	Datum is estimated, bias unknown; CVS %D and %D between primary and secondary GC columns outside acceptance criteria
RS	RS-140206-1330	02/14/06	SW-846 8082	2,2',3,4,5'-Pentachlorobiphenyl	15 D	µg/kg	CONF	1000	%	J	None	Datum is estimated, bias unknown; %D between primary and secondary GC columns outside acceptance criterion
RS	RS-140206-1330	02/14/06	SW-846 8082	2,2',5,5'-Tetrachlorobiphenyl	48 D	µg/kg	CONF	149	%	J	None	Datum is estimated, bias unknown; %D between primary and secondary GC columns outside acceptance criterion
RS	RS-140206-1330	02/14/06	SW-846 8082	2-Chlorobiphenyl	17 TD	µg/kg	CONF	290	%	J	None	Datum is estimated, bias unknown; %D between primary and secondary GC columns outside acceptance criterion
RS	RS-140206-1330	02/14/06	SW-846 8270C	Fluoranthene	3000 TD	µg/kg	LCS	121	%	J	High	Datum is estimated, possible high bias; LCS recovery outside acceptance criteria
RS	RS-140206-1330	02/14/06	SW-846 8290	1,2,3,4,6,7,8-Heptachlorodibenzo-p-dioxin	2500	pg/g	LB	0.37 T	pg/g	B	None	Analyte detected in associated blank; sample concentration greater than five times the blank concentration
RS	RS-140206-1330	02/14/06	SW-846 8290	1,2,3,4,7,8,9-Heptachlorodibenzofuran	49	pg/g	LB	0.34 T	pg/g	B	None	Analyte detected in associated blank; sample concentration greater than five times the blank concentration
RS	RS-140206-1330	02/14/06	SW-846 8290	1,2,3,4,7,8-Hexachlorodibenzo-p-dioxin	8.8 T	pg/g	IAR	0.93	N/A	J	None	Datum is estimated, bias unknown; ion abundance ratio outside acceptance criteria

TABLE 1
DATA QUALIFIERS SUMMARY TABLE
DEMONSTRATION TESTING AND FULL-SCALE OPERATION OF THE BIOGENESIS SEDIMENT DECONTAMINATION PROCESS, KEASBEY, NEW JERSEY
(Page85 of 188)

Location Identification	Sample Identification	Sample Date	Analysis	Analyte	Sample Result	Sample Units	QC Type	QC Result	QC Units	Qualifier	Bias	Comment
RS	RS-140206-1330	02/14/06	SW-846 8290	1,2,3,7,8,9-Hexachlorodibenzofuran	5.3 T	pg/g	LB	0.26 T	pg/g	B	None	Analyte detected in associated blank; sample concentration greater than five times the blank concentration
RS	RS-140206-1330	02/14/06	SW-846 8290	1,2,3,7,8-Pentachlorodibenzo-p-dioxin	8.2 T	pg/g	IAR	1.25	N/A	J	None	Datum is estimated, bias unknown; ion abundance ratio outside acceptance criteria
RS	RS-140206-1330	02/14/06	SW-846 8290	2,3,7,8-Tetrachlorodibenzofuran	34	pg/g	IAR	0.4	N/A	J	None	Datum is estimated, bias unknown; ion abundance ratio outside acceptance criteria
RS	RS-140206-1330	02/14/06	SW-846 8290	Octachlorodibenzo-p-dioxin	16000	pg/g	LB	1.0 T	pg/g	B	None	Analyte detected in associated blank; sample concentration greater than five times the blank concentration
RS	RS-140206-1330	02/14/06	SW-846 8290	Octachlorodibenzofuran	1300	pg/g	LB	0.58 T	pg/g	B	None	Analyte detected in associated blank; sample concentration greater than five times the blank concentration
RS	RS-140206-1330	02/14/06	SW-846 8081A	Dieldrin	24	µg/kg	CONF	1000	%	J	None	Datum is estimated, bias unknown; %D between primary and secondary GC columns outside acceptance criterion
RS	RS-140206-1330	02/14/06	SW-846 8081A	beta Endosulfan	25	µg/kg	CONF	75.6	%	J	None	Datum is estimated, bias unknown; %D between primary and secondary GC columns outside acceptance criterion
RS	RS-140206-1330	02/14/06	SW-846 8081A	Endrin	8.9	µg/kg	CONF	347	%	J	None	Datum is estimated, bias unknown; %D between primary and secondary GC columns outside acceptance criterion
RS	RS-140206-1330	02/14/06	SW-846 8081A	Alpha-Chlordane	13	µg/kg	CONF	1000	%	J	None	Datum is estimated, bias unknown; %D between primary and secondary GC columns outside acceptance criterion
RS	RS-140206-1330	02/14/06	SW-846 8081A	Gamma-Chlordane	15	µg/kg	CONF	73	%	J	None	Datum is estimated, bias unknown; %D between primary and secondary GC columns outside acceptance criterion
RS	RS-140206-1330	02/14/06	SW-846 8081A	Aldrin	8.4	µg/kg	CONF	238	%	J	None	Datum is estimated, bias unknown; %D between primary and secondary GC columns outside acceptance criterion
RS	RS-140206-1330	02/14/06	SW-846 8081A	p,p'-DDD	240	µg/kg	CONF	629	%	J	None	Datum is estimated, bias unknown; %D between primary and secondary GC columns outside acceptance criterion
RS	RS-140206-1330	02/14/06	SW-846 8081A	p,p'-DDT	100	µg/kg	CONF	169	%	J	None	Datum is estimated, bias unknown; %D between primary and secondary GC columns outside acceptance criterion
TS	TS-140206-1331	02/14/06	SW-846 6010B	Silver	0.87	mg/kg	LB	0.030 T	mg/kg	B	None	Analyte detected in associated blank; sample concentration greater than five times the blank concentration
TS	TS-140206-1331	02/14/06	SW-846 6010B	Zinc	168	mg/kg	LB	0.40 T	mg/kg	B	None	Analyte detected in associated blank; sample concentration greater than five times the blank concentration
TS	TS-140206-1331	02/14/06	SW-846 7471A	Mercury	2.7	mg/kg	CVS	116	%	J	None	Datum is estimated, bias unknown; CVS %D outside acceptance criterion

TABLE 1
DATA QUALIFIERS SUMMARY TABLE
DEMONSTRATION TESTING AND FULL-SCALE OPERATION OF THE BIOGENESIS SEDIMENT DECONTAMINATION PROCESS, KEASBEY, NEW JERSEY
(Page 86 of 188)

Location Identification	Sample Identification	Sample Date	Analysis	Analyte	Sample Result	Sample Units	QC Type	QC Result	QC Units	Qualifier	Bias	Comment
TS	TS-140206-1331	02/14/06	SW-846 8082	2,2',3,3',4,4',5,5',6-Nonachlorobiphenyl	3 4 D	µg/kg	CONF CVS	40 6 -15 7	%	J	None	Datum is estimated, bias unknown; CVS %D and %D between primary and secondary GC columns outside acceptance criteria
TS	TS-140206-1331	02/14/06	SW-846 8082	2,2',3,4,4',5,5'-Heptachlorobiphenyl	9 8 D	µg/kg	CONF CVS	100 -27 8	%	J	None	Datum is estimated, bias unknown; CVS %D and %D between primary and secondary GC columns outside acceptance criteria
TS	TS-140206-1331	02/14/06	SW-846 8082	2,2',3,4,5'-Pentachlorobiphenyl	7 3 D	µg/kg	CONF	1000	%	J	None	Datum is estimated, bias unknown; %D between primary and secondary GC columns outside acceptance criterion
TS	TS-140206-1331	02/14/06	SW-846 8082	2,2',5,5'-Tetrachlorobiphenyl	20 D	µg/kg	CONF	90 5	%	J	None	Datum is estimated, bias unknown; %D between primary and secondary GC columns outside acceptance criterion
TS	TS-140206-1331	02/14/06	SW-846 8082	2,3,3',4',6-Pentachlorobiphenyl	6 6 D	µg/kg	CONF	184	%	J	None	Datum is estimated, bias unknown; %D between primary and secondary GC columns outside acceptance criterion
TS	TS-140206-1331	02/14/06	SW-846 8082	2,3-Dichlorobiphenyl	3 5 D	µg/kg	CONF	203	%	J	None	Datum is estimated, bias unknown; %D between primary and secondary GC columns outside acceptance criterion
TS	TS-140206-1331	02/14/06	SW-846 8270C	Benzo(b)fluoranthene	800 TD	µg/kg	MS	46	%	J	Low	Datum is estimated, possible low bias; MS recovery outside acceptance criteria
TS	TS-140206-1331	02/14/06	SW-846 8270C	Fluoranthene	2100 TD	µg/kg	LCS MSD	121 126	%	J	High	Datum is estimated, possible high bias; LCS and MSD recoveries outside acceptance criteria
TS	TS-140206-1331	02/14/06	SW-846 8270C	Hexachloroethane	<4400 D	µg/kg	MS MSD	34 36	%	UJ	Low	Possible false negative; MS/MSD recoveries outside acceptance criteria
TS	TS-140206-1331	02/14/06	SW-846 8270C	Indeno(1,2,3-c,d)pyrene	430 TD	µg/kg	MS	47	%	J	Low	Datum is estimated, possible low bias; MS recovery outside acceptance criteria
TS	TS-140206-1331	02/14/06	SW-846 8290	1,2,3,4,6,7,8-Heptachlorodibenzo-p-dioxin	110	pg/g	LB	0 37 T	pg/g	B	None	Analyte detected in associated blank; sample concentration greater than five times the blank concentration
TS	TS-140206-1331	02/14/06	SW-846 8290	1,2,3,4,7,8,9-Heptachlorodibenzofuran	3 4 T	pg/g	LB	0 34 T	pg/g	B	None	Analyte detected in associated blank; sample concentration greater than five times the blank concentration
TS	TS-140206-1331	02/14/06	SW-846 8290	1,2,3,4,7,8-Hexachlorodibenzo-p-dioxin	0 48 T	pg/g	IAR	0 44	N/A	J	None	Datum is estimated, bias unknown; ion abundance ratio outside acceptance criteria
TS	TS-140206-1331	02/14/06	SW-846 8290	1,2,3,4,7,8-Hexachlorodibenzofuran	16	pg/g	PDE	N/A	N/A	J	None	Datum is estimated, bias unknown; interfering polychlorinated diphenyl ether peak present
TS	TS-140206-1331	02/14/06	SW-846 8290	1,2,3,7,8,9-Hexachlorodibenzo-p-Dioxin	3 2 T	pg/g	IAR	0 99	N/A	J	None	Datum is estimated, bias unknown; ion abundance ratio outside acceptance criteria
TS	TS-140206-1331	02/14/06	SW-846 8290	1,2,3,7,8-Pentachlorodibenzo-p-dioxin	1 0 T	pg/g	IAR	1 14	N/A	J	None	Datum is estimated, bias unknown; ion abundance ratio outside acceptance criteria
TS	TS-140206-1331	02/14/06	SW-846 8290	2,3,7,8-Tetrachlorodibenzofuran	2 8	pg/g	IAR	0 94	N/A	J	None	Datum is estimated, bias unknown; ion abundance ratio outside acceptance criteria

TABLE 1
DATA QUALIFIERS SUMMARY TABLE
DEMONSTRATION TESTING AND FULL-SCALE OPERATION OF THE BIOGENESIS SEDIMENT DECONTAMINATION PROCESS, KEASBEY, NEW JERSEY
(Page87 of 188)

Location Identification	Sample Identification	Sample Date	Analysis	Analyte	Sample Result	Sample Units	QC Type	QC Result	QC Units	Qualifier	Bias	Comment
TS	TS-140206-1331	02/14/06	SW-846 8290	Octachlorodibenzo-p-dioxin	1300	pg/g	LB	1 0 T	pg/g	B	None	Analyte detected in associated blank; sample concentration greater than five times the blank concentration
TS	TS-140206-1331	02/14/06	SW-846 8290	Octachlorodibenzofuran	78	pg/g	LB	0 58 T	pg/g	B	None	Analyte detected in associated blank; sample concentration greater than five times the blank concentration
TS	TS-140206-1331	02/14/06	SW-846 8081A	Dieldrin	4 6	µg/kg	CONF	1000	%	J	None	Datum is estimated, bias unknown; %D between primary and secondary GC columns outside acceptance criterion
TS	TS-140206-1331	02/14/06	SW-846 8081A	Endrin	6 7	µg/kg	CONF	81 7	%	J	None	Datum is estimated, bias unknown; %D between primary and secondary GC columns outside acceptance criterion
TS	TS-140206-1331	02/14/06	SW-846 8081A	Alpha-Chlordane	7 9	µg/kg	CONF	559	%	J	None	Datum is estimated, bias unknown; %D between primary and secondary GC columns outside acceptance criterion
TS	TS-140206-1331	02/14/06	SW-846 8081A	Aldrin	7 3	µg/kg	CONF	344	%	J	None	Datum is estimated, bias unknown; %D between primary and secondary GC columns outside acceptance criterion
TS	TS-140206-1331	02/14/06	SW-846 8081A	p,p'-DDD	140	µg/kg	CONF	942	%	J	None	Datum is estimated, bias unknown; %D between primary and secondary GC columns outside acceptance criterion
WS	WS-140206-1332	02/14/06	SW-846 6010B	Silver	10	mg/kg	LB	0 030 T	mg/kg	B	None	Analyte detected in associated blank; sample concentration greater than five times the blank concentration
WS	WS-140206-1332	02/14/06	SW-846 6010B	Zinc	766	mg/kg	LB	0 40 T	mg/kg	B	None	Analyte detected in associated blank; sample concentration greater than five times the blank concentration
WS	WS-140206-1332	02/14/06	SW-846 7471A	Mercury	16	mg/kg	CVS	116	%	J	None	Datum is estimated, bias unknown; CVS %D outside acceptance criterion
WS	WS-140206-1332	02/14/06	SW-846 8082	2,2',3,3',4,4',5,5',6-Nonachlorobiphenyl	8 5 D	µg/kg	CVS	-15 7	%	J	None	Datum is estimated, bias unknown; CVS %D outside acceptance criterion
WS	WS-140206-1332	02/14/06	SW-846 8082	2,2',3,4,4',5,5'-Heptachlorobiphenyl	17 D	µg/kg	CONF CVS	76 3 -27 8	%	J	None	Datum is estimated, bias unknown; CVS %D and %D between primary and secondary GC columns outside acceptance criteria
WS	WS-140206-1332	02/14/06	SW-846 8082	2,2',3,4,5'-Pentachlorobiphenyl	16 D	µg/kg	CONF	1000	%	J	None	Datum is estimated, bias unknown; %D between primary and secondary GC columns outside acceptance criterion
WS	WS-140206-1332	02/14/06	SW-846 8082	2,2',3,5,5',6-Hexachlorobiphenyl	1 8 TD	µg/kg	CONF	850	%	J	None	Datum is estimated, bias unknown; %D between primary and secondary GC columns outside acceptance criterion
WS	WS-140206-1332	02/14/06	SW-846 8082	2,2',5,5'-Tetrachlorobiphenyl	53 D	µg/kg	CONF	47 8	%	J	None	Datum is estimated, bias unknown; %D between primary and secondary GC columns outside acceptance criterion
WS	WS-140206-1332	02/14/06	SW-846 8082	2,3-Dichlorobiphenyl	8 4 D	µg/kg	CONF	112	%	J	None	Datum is estimated, bias unknown; %D between primary and secondary GC columns outside acceptance criterion

TABLE 1
DATA QUALIFIERS SUMMARY TABLE
DEMONSTRATION TESTING AND FULL-SCALE OPERATION OF THE BIOGENESIS SEDIMENT DECONTAMINATION PROCESS, KEASBEY, NEW JERSEY
(Page88 of 188)

Location Identification	Sample Identification	Sample Date	Analysis	Analyte	Sample Result	Sample Units	QC Type	QC Result	QC Units	Qualifier	Bias	Comment
WS	WS-140206-1332	02/14/06	SW-846 8082	2-Chlorobiphenyl	17 TD	µg/kg	CONF	229	%	J	None	Datum is estimated, bias unknown; %D between primary and secondary GC columns outside acceptance criterion
WS	WS-140206-1332	02/14/06	SW-846 8270C	Fluoranthene	1500 TD	µg/kg	LCS	121	%	J	High	Datum is estimated, possible high bias; LCS recovery outside acceptance criteria
WS	WS-140206-1332	02/14/06	SW-846 8290	1,2,3,4,6,7,8-Heptachlorodibenzo-p-dioxin	510	pg/g	LB	0.37 T	pg/g	B	None	Analyte detected in associated blank; sample concentration greater than five times the blank concentration
WS	WS-140206-1332	02/14/06	SW-846 8290	1,2,3,4,7,8,9-Heptachlorodibenzofuran	24	pg/g	LB	0.34 T	pg/g	B	None	Analyte detected in associated blank; sample concentration greater than five times the blank concentration
WS	WS-140206-1332	02/14/06	SW-846 8290	1,2,3,4,7,8-Hexachlorodibenzo-p-dioxin	4.5 T	pg/g	IAR	1.73	N/A	J	None	Datum is estimated, bias unknown; ion abundance ratio outside acceptance criteria
WS	WS-140206-1332	02/14/06	SW-846 8290	1,2,3,4,7,8-Hexachlorodibenzofuran	87	pg/g	PDE	N/A	N/A	J	None	Datum is estimated, bias unknown; interfering polychlorinated diphenyl ether peak present
WS	WS-140206-1332	02/14/06	SW-846 8290	1,2,3,7,8,9-Hexachlorodibenzofuran	4.3 T	pg/g	LB	0.26 T	pg/g	B	None	Analyte detected in associated blank; sample concentration greater than five times the blank concentration
WS	WS-140206-1332	02/14/06	SW-846 8290	1,2,3,7,8-Pentachlorodibenzofuran	13 T	pg/g	IAR	1.82	N/A	J	None	Datum is estimated, bias unknown; ion abundance ratio outside acceptance criteria
WS	WS-140206-1332	02/14/06	SW-846 8290	2,3,7,8-Tetrachlorodibenzofuran	16	pg/g	IAR	0.64	N/A	J	None	Datum is estimated, bias unknown; ion abundance ratio outside acceptance criteria
WS	WS-140206-1332	02/14/06	SW-846 8290	Octachlorodibenzo-p-dioxin	6800	pg/g	LB	1.0 T	pg/g	B	None	Analyte detected in associated blank; sample concentration greater than five times the blank concentration
WS	WS-140206-1332	02/14/06	SW-846 8290	Octachlorodibenzofuran	500	pg/g	LB	0.58 T	pg/g	B	None	Analyte detected in associated blank; sample concentration greater than five times the blank concentration
WS	WS-140206-1332	02/14/06	SW-846 8081A	Dieldrin	7.9	µg/kg	CONF	991	%	J	None	Datum is estimated, bias unknown; %D between primary and secondary GC columns outside acceptance criterion
WS	WS-140206-1332	02/14/06	SW-846 8081A	Gamma-Chlordane	4.6	µg/kg	CONF	87.9	%	J	None	Datum is estimated, bias unknown; %D between primary and secondary GC columns outside acceptance criterion
WS	WS-140206-1332	02/14/06	SW-846 8081A	Aldrin	4.4	µg/kg	CONF	162	%	J	None	Datum is estimated, bias unknown; %D between primary and secondary GC columns outside acceptance criterion
WS	WS-140206-1332	02/14/06	SW-846 8081A	p,p'-DDD	56	µg/kg	CONF	938	%	J	None	Datum is estimated, bias unknown; %D between primary and secondary GC columns outside acceptance criterion
WS	WS-140206-1332	02/14/06	SW-846 8081A	p,p'-DDT	19	µg/kg	CONF	290	%	J	None	Datum is estimated, bias unknown; %D between primary and secondary GC columns outside acceptance criterion

TABLE 1
DATA QUALIFIERS SUMMARY TABLE
DEMONSTRATION TESTING AND FULL-SCALE OPERATION OF THE BIOGENESIS SEDIMENT DECONTAMINATION PROCESS, KEASBEY, NEW JERSEY
(Page89 of 188)

Location Identification	Sample Identification	Sample Date	Analysis	Analyte	Sample Result	Sample Units	QC Type	QC Result	QC Units	Qualifier	Bias	Comment
RS	RS-160206-1500	02/16/06	SW-846 8270 SIM	Benzo(g,h,i)perylene	600 D	µg/kg	CVS	43 6	%	J	None	Datum is estimated, bias unknown; CVS %D outside acceptance criterion
RS	RS-160206-1500	02/16/06	SW-846 6010B	Silver	3 7	mg/kg	LB	0 030 T	mg/kg	B	None	Analyte detected in associated blank; sample concentration greater than five times the blank concentration
RS	RS-160206-1500	02/16/06	SW-846 6010B	Zinc	389	mg/kg	LB	0 40 T	mg/kg	B	None	Analyte detected in associated blank; sample concentration greater than five times the blank concentration
RS	RS-160206-1500	02/16/06	SW-846 8082	2,2',3,3',4,4',5,5',6-Nonachlorobiphenyl	13 D	µg/kg	CVS	-20 6	%	J	None	Datum is estimated, bias unknown; CVS %D outside acceptance criterion
RS	RS-160206-1500	02/16/06	SW-846 8082	2,2',3,4,4',5,5'-Heptachlorobiphenyl	20 D	µg/kg	CONF	40 6	%	J	None	Datum is estimated, bias unknown; %D between primary and secondary GC columns outside acceptance criterion
RS	RS-160206-1500	02/16/06	SW-846 8082	2,2',3,4,5'-Pentachlorobiphenyl	21 D	µg/kg	CONF	1000	%	J	None	Datum is estimated, bias unknown; %D between primary and secondary GC columns outside acceptance criterion
RS	RS-160206-1500	02/16/06	SW-846 8082	2,2',3,5,5',6-Hexachlorobiphenyl	1 9 TD	µg/kg	CONF	853	%	J	None	Datum is estimated, bias unknown; %D between primary and secondary GC columns outside acceptance criterion
RS	RS-160206-1500	02/16/06	SW-846 8082	2,2',5,5'-Tetrachlorobiphenyl	64 D	µg/kg	CONF	50 5	%	J	None	Datum is estimated, bias unknown; %D between primary and secondary GC columns outside acceptance criterion
RS	RS-160206-1500	02/16/06	SW-846 8082	2,2',5-Trichlorobiphenyl	60 D	µg/kg	CVS	-37 7	%	J	None	Datum is estimated, bias unknown; CVS %D outside acceptance criterion
RS	RS-160206-1500	02/16/06	SW-846 8082	2,3-Dichlorobiphenyl	10 D	µg/kg	CONF	173	%	J	None	Datum is estimated, bias unknown; %D between primary and secondary GC columns outside acceptance criterion
RS	RS-160206-1500	02/16/06	SW-846 8290	1,2,3,4,7,8-Hexachlorodibenzo-p-dioxin	7 1 T	pg/g	IAR	0 89	N/A	J	None	Datum is estimated, bias unknown; ion abundance ratio outside acceptance criteria
RS	RS-160206-1500	02/16/06	SW-846 8290	1,2,3,7,8-Pentachlorodibenzo-p-dioxin	5 3 T	pg/g	IAR	1 06	N/A	J	None	Datum is estimated, bias unknown; ion abundance ratio outside acceptance criteria
RS	RS-160206-1500	02/16/06	SW-846 8290	2,3,7,8-Tetrachlorodibenzofuran	24	pg/g	PDE	N/A	N/A	J	None	Datum is estimated, bias unknown; interfering polychlorinated diphenyl ether peak present
RS	RS-160206-1500	02/16/06	SW-846 8081A	Dieldrin	14	µg/kg	CONF	995	%	J	None	Datum is estimated, bias unknown; %D between primary and secondary GC columns outside acceptance criterion
RS	RS-160206-1500	02/16/06	SW-846 8081A	beta Endosulfan	14	µg/kg	CONF	106	%	J	None	Datum is estimated, bias unknown; %D between primary and secondary GC columns outside acceptance criterion
RS	RS-160206-1500	02/16/06	SW-846 8081A	Endrin	2 9	µg/kg	CONF	887	%	J	None	Datum is estimated, bias unknown; %D between primary and secondary GC columns outside acceptance criterion
RS	RS-160206-1500	02/16/06	SW-846 8081A	Alpha-Chlordane	4 9	µg/kg	CONF	1000	%	J	None	Datum is estimated, bias unknown; %D between primary and secondary GC columns outside acceptance criterion

TABLE 1
DATA QUALIFIERS SUMMARY TABLE
DEMONSTRATION TESTING AND FULL-SCALE OPERATION OF THE BIOGENESIS SEDIMENT DECONTAMINATION PROCESS, KEASBEY, NEW JERSEY
(Page90 of 188)

Location Identification	Sample Identification	Sample Date	Analysis	Analyte	Sample Result	Sample Units	QC Type	QC Result	QC Units	Qualifier	Bias	Comment
RS	RS-160206-1500	02/16/06	SW-846 8081A	Gamma-Chlordane	3 7	µg/kg	CONF	191	%	J	None	Datum is estimated, bias unknown; %D between primary and secondary GC columns outside acceptance criterion
TS	TS-160206-1501	02/16/06	SW-846 8270 SIM	Benzo(g,h,i)perylene	610 D	µg/kg	CVS	43 6	%	J	None	Datum is estimated, bias unknown; CVS %D outside acceptance criterion
TS	TS-160206-1501	02/16/06	SW-846 6010B	Silver	2	mg/kg	LB	0 030 T	mg/kg	B	None	Analyte detected in associated blank; sample concentration greater than five times the blank concentration
TS	TS-160206-1501	02/16/06	SW-846 6010B	Zinc	231	mg/kg	LB	0 40 T	mg/kg	B	None	Analyte detected in associated blank; sample concentration greater than five times the blank concentration
TS	TS-160206-1501	02/16/06	SW-846 8082	2,2',3,3',4,4',5,5',6-Nonachlorobiphenyl	13 D	µg/kg	CVS	-20 6	%	J	None	Datum is estimated, bias unknown; CVS %D outside acceptance criterion
TS	TS-160206-1501	02/16/06	SW-846 8082	2,2',3,4,4',5,5'-Heptachlorobiphenyl	5 4 D	µg/kg	CONF	61 7	%	J	None	Datum is estimated, bias unknown; %D between primary and secondary GC columns outside acceptance criterion
TS	TS-160206-1501	02/16/06	SW-846 8082	2,2',3,4,5'-Pentachlorobiphenyl	6 5 D	µg/kg	CONF	1000	%	J	None	Datum is estimated, bias unknown; %D between primary and secondary GC columns outside acceptance criterion
TS	TS-160206-1501	02/16/06	SW-846 8082	2,2',4,5,5'-Pentachlorobiphenyl	8 2 D	µg/kg	CONF	89 6	%	J	None	Datum is estimated, bias unknown; %D between primary and secondary GC columns outside acceptance criterion
TS	TS-160206-1501	02/16/06	SW-846 8082	2,2',5,5'-Tetrachlorobiphenyl	18 D	µg/kg	CONF	119	%	J	None	Datum is estimated, bias unknown; %D between primary and secondary GC columns outside acceptance criterion
TS	TS-160206-1501	02/16/06	SW-846 8082	2,2',5-Trichlorobiphenyl	18 D	µg/kg	CVS	-37 7	%	J	None	Datum is estimated, bias unknown; CVS %D outside acceptance criterion
TS	TS-160206-1501	02/16/06	SW-846 8082	2,3-Dichlorobiphenyl	3 1 D	µg/kg	CONF	246	%	J	None	Datum is estimated, bias unknown; %D between primary and secondary GC columns outside acceptance criterion
TS	TS-160206-1501	02/16/06	SW-846 8270C	Benzo(g,h,i)perylene	470 TD	µg/kg	MS	44	%	J	Low	Datum is estimated, possible low bias; MS recovery outside acceptance criteria
TS	TS-160206-1501	02/16/06	SW-846 8270C	Fluoranthene	1800 D	µg/kg	MS MSD	146 174	%	J	High	Datum is estimated, possible high bias; MS/MSD recoveries outside acceptance criteria
TS	TS-160206-1501	02/16/06	SW-846 8270C	Hexachloroethane	<1200 D	µg/kg	MSD	40	%	UJ	Low	Possible false negative; MSD recovery outside acceptance criteria
TS	TS-160206-1501	02/16/06	SW-846 8290	1,2,3,4,7,8,9-Heptachlorodibenzofuran	3 7 T	pg/g	IAR	1 38	N/A	J	None	Datum is estimated, bias unknown; ion abundance ratio outside acceptance criteria
TS	TS-160206-1501	02/16/06	SW-846 8290	1,2,3,4,7,8-Hexachlorodibenzo-p-dioxin	0 84 T	pg/g	IAR	0 68	N/A	J	None	Datum is estimated, bias unknown; ion abundance ratio outside acceptance criteria
TS	TS-160206-1501	02/16/06	SW-846 8290	1,2,3,6,7,8-Hexachlorodibenzo-p-Dioxin	3 7 T	pg/g	IAR	1 68	N/A	J	None	Datum is estimated, bias unknown; ion abundance ratio outside acceptance criteria

TABLE 1
DATA QUALIFIERS SUMMARY TABLE
DEMONSTRATION TESTING AND FULL-SCALE OPERATION OF THE BIOGENESIS SEDIMENT DECONTAMINATION PROCESS, KEASBEY, NEW JERSEY
(Page91 of 188)

Location Identification	Sample Identification	Sample Date	Analysis	Analyte	Sample Result	Sample Units	QC Type	QC Result	QC Units	Qualifier	Bias	Comment
TS	TS-160206-1501	02/16/06	SW-846 8290	2,3,7,8-Tetrachlorodibenzofuran	3.7	pg/g	IAR	1.04	N/A	J	None	Datum is estimated, bias unknown; ion abundance ratio outside acceptance criteria
TS	TS-160206-1501	02/16/06	SW-846 8081A	Dieldrin	5.4	µg/kg	CONF	1000	%	J	None	Datum is estimated, bias unknown; %D between primary and secondary GC columns outside acceptance criterion
TS	TS-160206-1501	02/16/06	SW-846 8081A	Endrin	2.7	µg/kg	CONF	339	%	J	None	Datum is estimated, bias unknown; %D between primary and secondary GC columns outside acceptance criterion
TS	TS-160206-1501	02/16/06	SW-846 8081A	Alpha-Chlordane	3.1	µg/kg	CONF	1000	%	J	None	Datum is estimated, bias unknown; %D between primary and secondary GC columns outside acceptance criterion
TS	TS-160206-1501	02/16/06	SW-846 8081A	Gamma-Chlordane	2.3	µg/kg	CONF	144	%	J	None	Datum is estimated, bias unknown; %D between primary and secondary GC columns outside acceptance criterion
WS	WS-160206-1502	02/16/06	SW-846 8270 SIM	Benzo(g,h,i)perylene	150 D	µg/kg	CVS	43.6	%	J	None	Datum is estimated, bias unknown; CVS %D outside acceptance criterion
WS	WS-160206-1502	02/16/06	SW-846 6010B	Silver	8.1	mg/kg	LB	0.030 T	mg/kg	B	None	Analyte detected in associated blank; sample concentration greater than five times the blank concentration
WS	WS-160206-1502	02/16/06	SW-846 6010B	Zinc	676	mg/kg	LB	0.40 T	mg/kg	B	None	Analyte detected in associated blank; sample concentration greater than five times the blank concentration
WS	WS-160206-1502	02/16/06	SW-846 8082	2,2',3,3',4,4',5,5',6-Nonachlorobiphenyl	8.1 D	µg/kg	CVS	-20.6	%	J	None	Datum is estimated, bias unknown; CVS %D outside acceptance criterion
WS	WS-160206-1502	02/16/06	SW-846 8082	2,2',3,4,4',5,5'-Heptachlorobiphenyl	16 D	µg/kg	CONF	68.5	%	J	None	Datum is estimated, bias unknown; %D between primary and secondary GC columns outside acceptance criterion
WS	WS-160206-1502	02/16/06	SW-846 8082	2,2',3,4,5'-Pentachlorobiphenyl	17 D	µg/kg	CONF	1000	%	J	None	Datum is estimated, bias unknown; %D between primary and secondary GC columns outside acceptance criterion
WS	WS-160206-1502	02/16/06	SW-846 8082	2,2',3,5,5',6-Hexachlorobiphenyl	1.6 TD	µg/kg	CONF	882	%	J	None	Datum is estimated, bias unknown; %D between primary and secondary GC columns outside acceptance criterion
WS	WS-160206-1502	02/16/06	SW-846 8082	2,2',5,5'-Tetrachlorobiphenyl	54 D	µg/kg	CONF	55.5	%	J	None	Datum is estimated, bias unknown; %D between primary and secondary GC columns outside acceptance criterion
WS	WS-160206-1502	02/16/06	SW-846 8082	2,2',5-Trichlorobiphenyl	53 D	µg/kg	CVS	-37.7	%	J	None	Datum is estimated, bias unknown; CVS %D outside acceptance criterion
WS	WS-160206-1502	02/16/06	SW-846 8082	2,3-Dichlorobiphenyl	8.2 D	µg/kg	CONF	156	%	J	None	Datum is estimated, bias unknown; %D between primary and secondary GC columns outside acceptance criterion
WS	WS-160206-1502	02/16/06	SW-846 8082	2,4,5-Trichlorobiphenyl	55 D	µg/kg	CONF	40.6	%	J	None	Datum is estimated, bias unknown; %D between primary and secondary GC columns outside acceptance criterion
WS	WS-160206-1502	02/16/06	SW-846 8290	1,2,3,4,7,8,9-Heptachlorodibenzofuran	4.0 T	pg/g	IAR	1.21	N/A	J	None	Datum is estimated, bias unknown; ion abundance ratio outside acceptance criteria

TABLE 1
DATA QUALIFIERS SUMMARY TABLE
DEMONSTRATION TESTING AND FULL-SCALE OPERATION OF THE BIOGENESIS SEDIMENT DECONTAMINATION PROCESS, KEASBEY, NEW JERSEY
(Page92 of 188)

Location Identification	Sample Identification	Sample Date	Analysis	Analyte	Sample Result	Sample Units	QC Type	QC Result	QC Units	Qualifier	Bias	Comment
WS	WS-160206-1502	02/16/06	SW-846 8290	1,2,3,6,7,8-Hexachlorodibenzo-p-Dioxin	4 0 T	pg/g	IAR	1 03	N/A	J	None	Datum is estimated, bias unknown; ion abundance ratio outside acceptance criteria
WS	WS-160206-1502	02/16/06	SW-846 8290	2,3,4,6,7,8-Hexachlorodibenzofuran	2 6 T	pg/g	IAR	1 46	N/A	J	None	Datum is estimated, bias unknown; ion abundance ratio outside acceptance criteria
WS	WS-160206-1502	02/16/06	SW-846 8290	2,3,7,8-Tetrachlorodibenzo-p-dioxin	6	pg/g	IAR	0 98	N/A	J	None	Datum is estimated, bias unknown; ion abundance ratio outside acceptance criteria
WS	WS-160206-1502	02/16/06	SW-846 8290	2,3,7,8-Tetrachlorodibenzofuran	1 7 T	pg/g	IAR	0 97	N/A	J	None	Datum is estimated, bias unknown; ion abundance ratio outside acceptance criteria
WS	WS-160206-1502	02/16/06	SW-846 8081A	Dieldrin	9 6	µg/kg	CONF	1000	%	J	None	Datum is estimated, bias unknown; %D between primary and secondary GC columns outside acceptance criterion
WS	WS-160206-1502	02/16/06	SW-846 8081A	Endrin	4 1	µg/kg	CONF	352	%	J	None	Datum is estimated, bias unknown; %D between primary and secondary GC columns outside acceptance criterion
WS	WS-160206-1502	02/16/06	SW-846 8081A	Alpha-Chlordane	7	µg/kg	CONF	867	%	J	None	Datum is estimated, bias unknown; %D between primary and secondary GC columns outside acceptance criterion
WS	WS-160206-1502	02/16/06	SW-846 8081A	Gamma-Chlordane	4 6	µg/kg	CONF	70 5	%	J	None	Datum is estimated, bias unknown; %D between primary and secondary GC columns outside acceptance criterion
WS	WS-160206-1502	02/16/06	SW-846 8081A	p,p'-DDT	28	µg/kg	CONF	278	%	J	None	Datum is estimated, bias unknown; %D between primary and secondary GC columns outside acceptance criterion
RS	RS-170206-1100	02/17/06	SW-846 6010B	Barium	456	mg/kg	MSD	74	%	J	Low	Datum is estimated, possible low bias; MSD recovery outside acceptance criteria
RS	RS-170206-1100	02/17/06	SW-846 6010B	Lead	395	mg/kg	MSD	40	%	J	Low	Datum is estimated, possible low bias; MSD recovery outside acceptance criteria
RS	RS-170206-1100	02/17/06	SW-846 6010B	Silver	7 9	mg/kg	MS MSD	73 65	%	J	Low	Datum is estimated, possible low bias; MS/MSD recoveries outside acceptance criteria
RS	RS-170206-1100	02/17/06	SW-846 8082	2,2',3,4',5,5',6-Heptachlorobiphenyl	19 D	µg/kg	CVS	15 7	%	J	None	Datum is estimated, bias unknown; CVS %D outside acceptance criterion
RS	RS-170206-1100	02/17/06	SW-846 8082	2,2',3,4,5'-Pentachlorobiphenyl	21 D	µg/kg	CONF	1000	%	J	None	Datum is estimated, bias unknown; %D between primary and secondary GC columns outside acceptance criterion
RS	RS-170206-1100	02/17/06	SW-846 8082	2,2',3,5,5',6-Hexachlorobiphenyl	2 TD	µg/kg	CONF	815	%	J	None	Datum is estimated, bias unknown; %D between primary and secondary GC columns outside acceptance criterion
RS	RS-170206-1100	02/17/06	SW-846 8082	2,2',5,5'-Tetrachlorobiphenyl	57 D	µg/kg	CONF	72 3	%	J	None	Datum is estimated, bias unknown; %D between primary and secondary GC columns outside acceptance criterion
RS	RS-170206-1100	02/17/06	SW-846 8082	2,3-Dichlorobiphenyl	10 D	µg/kg	CONF	214	%	J	None	Datum is estimated, bias unknown; %D between primary and secondary GC columns outside acceptance criterion
RS	RS-170206-1100	02/17/06	SW-846 8270C	Anthracene	750 TD	µg/kg	RPD	27 3	%	J	None	Datum is estimated, bias unknown; LCS/LCD RPD outside acceptance criterion

TABLE 1
DATA QUALIFIERS SUMMARY TABLE
DEMONSTRATION TESTING AND FULL-SCALE OPERATION OF THE BIOGENESIS SEDIMENT DECONTAMINATION PROCESS, KEASBEY, NEW JERSEY
(Page93 of 188)

Location Identification	Sample Identification	Sample Date	Analysis	Analyte	Sample Result	Sample Units	QC Type	QC Result	QC Units	Qualifier	Bias	Comment
RS	RS-170206-1100	02/17/06	SW-846 8270C	Benzo(a)anthracene	1300 TD	µg/kg	RPD	25	%	J	None	Datum is estimated, bias unknown; LCS/LCD RPD outside acceptance criterion
RS	RS-170206-1100	02/17/06	SW-846 8270C	Benzo(a)pyrene	950 TD	µg/kg	RPD	39.6	%	J	None	Datum is estimated, bias unknown; LCS/LCD RPD outside acceptance criterion
RS	RS-170206-1100	02/17/06	SW-846 8270C	Benzo(b)fluoranthene	1100 TD	µg/kg	RPD	38.5	%	J	None	Datum is estimated, bias unknown; LCS/LCD RPD outside acceptance criterion
RS	RS-170206-1100	02/17/06	SW-846 8270C	Benzo(k)fluoranthene	410 TD	µg/kg	RPD	42.1	%	J	None	Datum is estimated, bias unknown; LCS/LCD RPD outside acceptance criterion
RS	RS-170206-1100	02/17/06	SW-846 8270C	Fluoranthene	2900 TD	µg/kg	RPD	27.7	%	J	None	Datum is estimated, bias unknown; LCS/LCD RPD outside acceptance criterion
TS	TS-170206-1101	02/17/06	SW-846 8290	1,2,3,4,7,8,9-Heptachlorodibenzofuran	3.5 T	pg/g	PDE	N/A	N/A	J	None	Datum is estimated, bias unknown; interfering polychlorinated diphenyl ether peak present
TS	TS-170206-1101	02/17/06	SW-846 8290	1,2,3,6,7,8-Hexachlorodibenzo-p-Dioxin	3.5 T	pg/g	IAR	1.03	N/A	J	None	Datum is estimated, bias unknown; ion abundance ratio outside acceptance criteria
TS	TS-170206-1101	02/17/06	SW-846 8290	1,2,3,7,8-Pentachlorodibenzofuran	1.9 T	pg/g	IAR	2.05	N/A	J	None	Datum is estimated, bias unknown; ion abundance ratio outside acceptance criteria
TS	TS-170206-1101	02/17/06	SW-846 8290	2,3,4,6,7,8-Hexachlorodibenzofuran	2.8 T	pg/g	IAR	1.47	N/A	J	None	Datum is estimated, bias unknown; ion abundance ratio outside acceptance criteria
TS	TS-170206-1101	02/17/06	SW-846 8290	2,3,7,8-Tetrachlorodibenzofuran	2.5	pg/g	IAR	0.45	N/A	J	None	Datum is estimated, bias unknown; ion abundance ratio outside acceptance criteria
TS	TS-170206-1101	02/17/06	SW-846 8290	Octachlorodibenzo-p-dioxin	480	pg/g	LB	0.43 T	pg/g	B	None	Analyte detected in associated blank; sample concentration greater than five times the blank concentration
TS	TS-170206-1101	02/17/06	SW-846 8081A	Dieldrin	4.8	µg/kg	CONF	1000	%	J	None	Datum is estimated, bias unknown; %D between primary and secondary GC columns outside acceptance criterion
TS	TS-170206-1101	02/17/06	SW-846 8081A	Endrin	4	µg/kg	CONF	146	%	J	None	Datum is estimated, bias unknown; %D between primary and secondary GC columns outside acceptance criterion
TS	TS-170206-1101	02/17/06	SW-846 8081A	Alpha-Chlordane	2.2	µg/kg	CONF	1000	%	J	None	Datum is estimated, bias unknown; %D between primary and secondary GC columns outside acceptance criterion
TS	TS-170206-1101	02/17/06	SW-846 8081A	Gamma-Chlordane	2	µg/kg	CONF	127	%	J	None	Datum is estimated, bias unknown; %D between primary and secondary GC columns outside acceptance criterion
TS	TS-170206-1101	02/17/06	SW-846 8081A	Aldrin	2.9	µg/kg	CONF	90.8	%	J	None	Datum is estimated, bias unknown; %D between primary and secondary GC columns outside acceptance criterion
TS	TS-170206-1101	02/17/06	SW-846 8081A	p,p'-DDD	79	µg/kg	CONF	598	%	J	None	Datum is estimated, bias unknown; %D between primary and secondary GC columns outside acceptance criterion

TABLE 1
DATA QUALIFIERS SUMMARY TABLE
DEMONSTRATION TESTING AND FULL-SCALE OPERATION OF THE BIOGENESIS SEDIMENT DECONTAMINATION PROCESS, KEASBEY, NEW JERSEY
(Page94 of 188)

Location Identification	Sample Identification	Sample Date	Analysis	Analyte	Sample Result	Sample Units	QC Type	QC Result	QC Units	Qualifier	Bias	Comment
TS	TS-170206-1101	02/17/06	SW-846 8270C	Anthracene	580 TD	µg/kg	RPD	27 3	%	J	None	Datum is estimated, bias unknown; LCS/LCD RPD outside acceptance criterion
TS	TS-170206-1101	02/17/06	SW-846 8270C	Benzo(a)anthracene	1100 D	µg/kg	RPD	25	%	J	None	Datum is estimated, bias unknown; LCS/LCD RPD outside acceptance criterion
TS	TS-170206-1101	02/17/06	SW-846 8270C	Benzo(a)pyrene	1000 TD	µg/kg	RPD	39 6	%	J	None	Datum is estimated, bias unknown; LCS/LCD RPD outside acceptance criterion
TS	TS-170206-1101	02/17/06	SW-846 8270C	Benzo(b)fluoranthene	940 TD	µg/kg	RPD	38 5	%	J	None	Datum is estimated, bias unknown; LCS/LCD RPD outside acceptance criterion
TS	TS-170206-1101	02/17/06	SW-846 8270C	Benzo(k)fluoranthene	340 TD	µg/kg	RPD	42 1	%	J	None	Datum is estimated, bias unknown; LCS/LCD RPD outside acceptance criterion
TS	TS-170206-1101	02/17/06	SW-846 8270C	Fluoranthene	1900 D	µg/kg	RPD	27 7	%	J	None	Datum is estimated, bias unknown; LCS/LCD RPD outside acceptance criterion
WS	WS-170206-1102	02/17/06	SW-846 6010B	Arsenic	58 7	mg/kg	SLD	10 4	%	J	None	Datum is estimated, bias unknown; serial dilution %D outside acceptance criterion
WS	WS-170206-1102	02/17/06	SW-846 6010B	Zinc	803	mg/kg	SLD	12 5	%	J	None	Datum is estimated, bias unknown; serial dilution %D outside acceptance criterion
WS	WS-170206-1102	02/17/06	SW-846 8082	2,2',3,3',4,4',5,5',6-Nonachlorobiphenyl	4 4 TD	µg/kg	CONF CVS	483 17 0	%	J	None	Datum is estimated, bias unknown; CVS %D and %D between primary and secondary GC columns outside acceptance criteria
WS	WS-170206-1102	02/17/06	SW-846 8082	2,2',3,3',4,4',5-Heptachlorobiphenyl	7 6 D	µg/kg	CONF	41	%	J	None	Datum is estimated, bias unknown; %D between primary and secondary GC columns outside acceptance criterion
WS	WS-170206-1102	02/17/06	SW-846 8082	2,2',3,4',5,5',6-Heptachlorobiphenyl	10 D	µg/kg	CVS	15 7	%	J	None	Datum is estimated, bias unknown; CVS %D outside acceptance criterion
WS	WS-170206-1102	02/17/06	SW-846 8082	2,2',3,4,4',5,5'-Heptachlorobiphenyl	9 D	µg/kg	CONF CVS	93 6 20 9	%	J	None	Datum is estimated, bias unknown; CVS %D and %D between primary and secondary GC columns outside acceptance criteria
WS	WS-170206-1102	02/17/06	SW-846 8082	2,2',3,4,5'-Pentachlorobiphenyl	9 9 D	µg/kg	CONF	1000	%	J	None	Datum is estimated, bias unknown; %D between primary and secondary GC columns outside acceptance criterion
WS	WS-170206-1102	02/17/06	SW-846 8082	2,2',3,5,5',6-Hexachlorobiphenyl	2 1 TD	µg/kg	CONF	270	%	J	None	Datum is estimated, bias unknown; %D between primary and secondary GC columns outside acceptance criterion
WS	WS-170206-1102	02/17/06	SW-846 8082	2,2',5,5'-Tetrachlorobiphenyl	30 D	µg/kg	CONF	51 8	%	J	None	Datum is estimated, bias unknown; %D between primary and secondary GC columns outside acceptance criterion
WS	WS-170206-1102	02/17/06	SW-846 8082	2,3-Dichlorobiphenyl	4 9 TD	µg/kg	CONF	161	%	J	None	Datum is estimated, bias unknown; %D between primary and secondary GC columns outside acceptance criterion
WS	WS-170206-1102	02/17/06	SW-846 8290	1,2,3,4,7,8,9-Heptachlorodibenzofuran	5 5 T	pg/g	IAR	1 22	N/A	J	None	Datum is estimated, bias unknown; ion abundance ratio outside acceptance criteria

TABLE 1
DATA QUALIFIERS SUMMARY TABLE
DEMONSTRATION TESTING AND FULL-SCALE OPERATION OF THE BIOGENESIS SEDIMENT DECONTAMINATION PROCESS, KEASBEY, NEW JERSEY
(Page95 of 188)

Location Identification	Sample Identification	Sample Date	Analysis	Analyte	Sample Result	Sample Units	QC Type	QC Result	QC Units	Qualifier	Bias	Comment
WS	WS-170206-1102	02/17/06	SW-846 8290	1,2,3,4,7,8-Hexachlorodibenzo-p-dioxin	1 9 T	pg/g	CMC	3	s	J	None	Datum is estimated, bias unknown; peaks comax outside acceptance criterion
WS	WS-170206-1102	02/17/06	SW-846 8290	1,2,3,7,8,9-Hexachlorodibenzo-p-Dioxin	4 4 T	pg/g	IAR CMC	0 94 3	N/A s	J	None	Datum is estimated, bias unknown; ion abundance ratio and comax peaks outside acceptance criteria
WS	WS-170206-1102	02/17/06	SW-846 8290	2,3,4,6,7,8-Hexachlorodibenzofuran	4 2 T	pg/g	IAR	1 44	N/A	J	None	Datum is estimated, bias unknown; ion abundance ratio outside acceptance criteria
WS	WS-170206-1102	02/17/06	SW-846 8290	2,3,4,7,8-Pentachlorodibenzofuran	5 3 T	pg/g	IAR	1 17	N/A	J	None	Datum is estimated, bias unknown; ion abundance ratio outside acceptance criteria
WS	WS-170206-1102	02/17/06	SW-846 8290	2,3,7,8-Tetrachlorodibenzofuran	4 5	pg/g	IAR	0 98	N/A	J	None	Datum is estimated, bias unknown; ion abundance ratio outside acceptance criteria
WS	WS-170206-1102	02/17/06	SW-846 8290	Octachlorodibenzo-p-dioxin	1300	pg/g	LB	0 43 T	pg/g	B	None	Analyte detected in associated blank; sample concentration greater than five times the blank concentration
WS	WS-170206-1102	02/17/06	SW-846 8081A	Dieldrin	3 7	µg/kg	CONF	1000	%	J	None	Datum is estimated, bias unknown; %D between primary and secondary GC columns outside acceptance criterion
WS	WS-170206-1102	02/17/06	SW-846 8081A	beta Endosulfan	5 4	µg/kg	CONF	260	%	J	None	Datum is estimated, bias unknown; %D between primary and secondary GC columns outside acceptance criterion
WS	WS-170206-1102	02/17/06	SW-846 8081A	Aldrin	5 6	µg/kg	CONF	65 9	%	J	None	Datum is estimated, bias unknown; %D between primary and secondary GC columns outside acceptance criterion
WS	WS-170206-1102	02/17/06	SW-846 8081A	p,p'-DDD	91	µg/kg	CONF	919	%	J	None	Datum is estimated, bias unknown; %D between primary and secondary GC columns outside acceptance criterion
WS	WS-170206-1102	02/17/06	SW-846 8081A	p,p'-DDT	15	µg/kg	CONF	934	%	J	None	Datum is estimated, bias unknown; %D between primary and secondary GC columns outside acceptance criterion
TS	TS-230206-0930	02/23/06	SW-846 6010B	Selenium	1 3	mg/kg	SLD	100	%	J	None	Datum is estimated, bias unknown; serial dilution %D outside acceptance criterion
TS	TS-230206-0930	02/23/06	SW-846 6010B	Zinc	212	mg/kg	SLD	12 1	%	J	None	Datum is estimated, bias unknown; serial dilution %D outside acceptance criterion
TS	TS-230206-0930	02/23/06	SW-846 8082	2,2',3,4,4',5,5'-Heptachlorobiphenyl	4 9 D	µg/kg	CONF	68 4	%	J	None	Datum is estimated, bias unknown; %D between primary and secondary GC columns outside acceptance criterion
TS	TS-230206-0930	02/23/06	SW-846 8082	2,2',3,4,5'-Pentachlorobiphenyl	6 D	µg/kg	CONF	1000	%	J	None	Datum is estimated, bias unknown; %D between primary and secondary GC columns outside acceptance criterion
TS	TS-230206-0930	02/23/06	SW-846 8082	2,2',5,5'-Tetrachlorobiphenyl	15 D	µg/kg	CONF	65 2	%	J	None	Datum is estimated, bias unknown; %D between primary and secondary GC columns outside acceptance criterion
TS	TS-230206-0930	02/23/06	SW-846 8270C	Benzo(a)anthracene	940 TD	µg/kg	MS	147	%	J	High	Datum is estimated, possible high bias; MS recovery outside acceptance criteria

TABLE 1
DATA QUALIFIERS SUMMARY TABLE
DEMONSTRATION TESTING AND FULL-SCALE OPERATION OF THE BIOGENESIS SEDIMENT DECONTAMINATION PROCESS, KEASBEY, NEW JERSEY
(Page 96 of 188)

Location Identification	Sample Identification	Sample Date	Analysis	Analyte	Sample Result	Sample Units	QC Type	QC Result	QC Units	Qualifier	Bias	Comment
TS	TS-230206-0930	02/23/06	SW-846 8270C	Benzo(a)pyrene	850 TD	µg/kg	MS	132	%	J	High	Datum is estimated, possible high bias; MS recovery outside acceptance criteria
TS	TS-230206-0930	02/23/06	SW-846 8270C	Benzo(g,h,i)perylene	720 TD	µg/kg	MS	124	%	J	High	Datum is estimated, possible high bias; MS recovery outside acceptance criteria
TS	TS-230206-0930	02/23/06	SW-846 8270C	Chrysene	1100 TD	µg/kg	MS	146	%	J	High	Datum is estimated, possible high bias; MS recovery outside acceptance criteria
TS	TS-230206-0930	02/23/06	SW-846 8270C	Fluoranthene	1700 TD	µg/kg	MS	236	%	J	High	Datum is estimated, possible high bias; MS/MSD recoveries outside acceptance criteria
TS	TS-230206-0930	02/23/06	SW-846 8270C	Pentachlorophenol	<11000 D	µg/kg	MS MSD	12 9 3	%	UJ	Low	Possible false negative; MS/MSD recoveries outside acceptance criteria
TS	TS-230206-0930	02/23/06	SW-846 8270C	Pyrene	1700 TD	µg/kg	MS	170	%	J	High	Datum is estimated, possible high bias; MS recovery outside acceptance criteria
TS	TS-230206-0930	02/23/06	SW-846 8290	1,2,3,4,6,7,8-Heptachlorodibenzo-p-dioxin	61	pg/g	MSD	198	%	J	High	Datum is estimated, possible high bias; MSD recovery outside acceptance criteria
TS	TS-230206-0930	02/23/06	SW-846 8290	1,2,3,4,6,7,8-Heptachlorodibenzofuran	36	pg/g	MSD LB	146 0 43 T	% pg/g	JB	High	Datum is estimated, possible high bias; MSD recovery outside acceptance criteria Analyte detected in associated blank; sample concentration greater than five times the blank concentration
TS	TS-230206-0930	02/23/06	SW-846 8290	1,2,3,4,7,8,9-Heptachlorodibenzofuran	3 3 T	pg/g	LB	0 47 T	pg/g	B	None	Analyte detected in associated blank; sample concentration greater than five times the blank concentration
TS	TS-230206-0930	02/23/06	SW-846 8290	1,2,3,4,7,8-Hexachlorodibenzo-p-dioxin	0 89 T	pg/g	IAR	0 86	N/A	J	None	Datum is estimated, bias unknown; ion abundance ratio outside acceptance criteria
TS	TS-230206-0930	02/23/06	SW-846 8290	1,2,3,4,7,8-Hexachlorodibenzofuran	11	pg/g	PDE LB	N/A 0 43 T	N/A pg/g	JB	None	Datum is estimated, bias unknown; interfering polychlorinated diphenyl ether peak present Analyte detected in associated blank; sample concentration greater than five times the blank concentration
TS	TS-230206-0930	02/23/06	SW-846 8290	1,2,3,6,7,8-Hexachlorodibenzo-p-Dioxin	3 1 T	pg/g	IAR	1 66	N/A	J	None	Datum is estimated, bias unknown; ion abundance ratio outside acceptance criteria
TS	TS-230206-0930	02/23/06	SW-846 8290	1,2,3,6,7,8-Hexachlorodibenzofuran	3 2 T	pg/g	LB	0 36 T	pg/g	B	None	Analyte detected in associated blank; sample concentration greater than five times the blank concentration
TS	TS-230206-0930	02/23/06	SW-846 8290	1,2,3,7,8,9-Hexachlorodibenzo-p-Dioxin	2 0 T	pg/g	IAR LB	0 87 0 49 T	N/A pg/g	JUB	None	Datum is estimated, bias unknown; ion abundance ratio outside acceptance criteria Analyte considered not detected, analyte detected in associated blank; sample concentration less than five times the blank concentration
TS	TS-230206-0930	02/23/06	SW-846 8290	1,2,3,7,8-Pentachlorodibenzo-p-dioxin	0 82 T	pg/g	IAR	1 05	N/A	J	None	Datum is estimated, bias unknown; ion abundance ratio outside acceptance criteria
TS	TS-230206-0930	02/23/06	SW-846 8290	1,2,3,7,8-Pentachlorodibenzofuran	2 5 T	pg/g	LB	0 39 T	pg/g	B	None	Analyte detected in associated blank; sample concentration greater than five times the blank concentration

TABLE 1
DATA QUALIFIERS SUMMARY TABLE
DEMONSTRATION TESTING AND FULL-SCALE OPERATION OF THE BIOGENESIS SEDIMENT DECONTAMINATION PROCESS, KEASBEY, NEW JERSEY
(Page97 of 188)

Location Identification	Sample Identification	Sample Date	Analysis	Analyte	Sample Result	Sample Units	QC Type	QC Result	QC Units	Qualifier	Bias	Comment
TS	TS-230206-0930	02/23/06	SW-846 8290	2,3,4,6,7,8-Hexachlorodibenzofuran	2 0 T	pg/g	IAR LB	1 51 0 38 T	N/A pg/g	JB	None	Datum is estimated, bias unknown; ion abundance ratio outside acceptance criteria Analyte detected in associated blank; sample concentration greater than five times the blank concentration
TS	TS-230206-0930	02/23/06	SW-846 8290	2,3,4,7,8-Pentachlorodibenzofuran	3 9 T	pg/g	LB	0 26 T	pg/g	B	None	Analyte detected in associated blank; sample concentration greater than five times the blank concentration
TS	TS-230206-0930	02/23/06	SW-846 8290	2,3,7,8-Tetrachlorodibenzo-p-dioxin	7 6	pg/g	MS MSD	440 146	%	J	High	Datum is estimated, possible high bias; MS/MSD recoveries outside acceptance criteria
TS	TS-230206-0930	02/23/06	SW-846 8290	Octachlorodibenzo-p-dioxin	690	pg/g	MS MSD LB	0 539 1 8 T	% pg/g	JB	Low	Datum is estimated, possible low bias; MS/MSD recoveries outside acceptance criteria Analyte detected in associated blank; sample concentration greater than five times blank concentration
TS	TS-230206-0930	02/23/06	SW-846 8290	Octachlorodibenzofuran	41	pg/g	MS LB	44 1 1 T	% pg/g	JB	Low	Datum is estimated, possible low bias; MS recovery outside acceptance criterion Analyte detected in associated blank; sample concentration greater than five times the blank concentration
TS	TS-230206-0930	02/23/06	SW-846 8081A	Dieldrin	5 3	µg/kg	CONF	1000	%	J	None	Datum is estimated, bias unknown; %D between primary and secondary GC columns outside acceptance criterion
TS	TS-230206-0930	02/23/06	SW-846 8081A	p,p'-DDD	81	µg/kg	CONF	1000	%	J	None	Datum is estimated, bias unknown; %D between primary and secondary GC columns outside acceptance criterion
TS	TS-230206-0930 DRIED	02/23/06	SW-846 8082	2,2',3,4,4',5,5'-Heptachlorobiphenyl	3 9 D	µg/kg	CONF	63 7	%	J	None	Datum is estimated, bias unknown; %D between primary and secondary GC columns outside acceptance criterion
TS	TS-230206-0930 DRIED	02/23/06	SW-846 8082	2,2',3,4,5'-Pentachlorobiphenyl	3 7 D	µg/kg	CONF	1000	%	J	None	Datum is estimated, bias unknown; %D between primary and secondary GC columns outside acceptance criterion
TS	TS-230206-0930 DRIED	02/23/06	SW-846 8082	2,2',5,5'-Tetrachlorobiphenyl	13 D	µg/kg	CONF	80 1	%	J	None	Datum is estimated, bias unknown; %D between primary and secondary GC columns outside acceptance criterion
TS	TS-230206-0930 DRIED	02/23/06	SW-846 8082	2,3-Dichlorobiphenyl	2 3 TD	µg/kg	CONF	244	%	J	None	Datum is estimated, bias unknown; %D between primary and secondary GC columns outside acceptance criterion
TS	TS-230206-0930 DRIED	02/23/06	SW-846 8270C	Benzo(a)anthracene	1100 TD	µg/kg	MS	147	%	J	High	Datum is estimated, possible high bias; MS recovery outside acceptance criteria
TS	TS-230206-0930 DRIED	02/23/06	SW-846 8270C	Benzo(a)pyrene	880 TD	µg/kg	MS	132	%	J	High	Datum is estimated, possible high bias; MS recovery outside acceptance criteria
TS	TS-230206-0930 DRIED	02/23/06	SW-846 8270C	Benzo(g,h,i)perylene	730 TD	µg/kg	MS	124	%	J	High	Datum is estimated, possible high bias; MS recovery outside acceptance criteria
TS	TS-230206-0930 DRIED	02/23/06	SW-846 8270C	Chrysene	1200 TD	µg/kg	MS	146	%	J	High	Datum is estimated, possible high bias; MS recovery outside acceptance criteria
TS	TS-230206-0930 DRIED	02/23/06	SW-846 8270C	Fluoranthene	1700 TD	µg/kg	MS MSD	236 129	%	J	High	Datum is estimated, possible high bias; MS/MSD recoveries outside acceptance criteria
TS	TS-230206-0930 DRIED	02/23/06	SW-846 8270C	Pentachlorophenol	<12000 D	µg/kg	MS MSD	12 9 3	%	UJ	Low	Possible false negative; MS/MSD recoveries outside acceptance criteria

TABLE 1
DATA QUALIFIERS SUMMARY TABLE
DEMONSTRATION TESTING AND FULL-SCALE OPERATION OF THE BIOGENESIS SEDIMENT DECONTAMINATION PROCESS, KEASBEY, NEW JERSEY
(Page98 of 188)

Location Identification	Sample Identification	Sample Date	Analysis	Analyte	Sample Result	Sample Units	QC Type	QC Result	QC Units	Qualifier	Bias	Comment
TS	TS-230206-0930 DRIED	02/23/06	SW-846 8270C	Pyrene	1800 TD	µg/kg	MS	170	%	J	High	Datum is estimated, possible high bias; MS recovery outside acceptance criteria
TS	TS-230206-0930 DRIED	02/23/06	SW-846 8290	1,2,3,4,6,7,8-Heptachlorodibenzo-p-dioxin	43	pg/g	MSD	198	%	J	High	Datum is estimated, possible high bias; MSD recovery outside acceptance criteria
TS	TS-230206-0930 DRIED	02/23/06	SW-846 8290	1,2,3,4,6,7,8-Heptachlorodibenzofuran	23	pg/g	MSD LB	146 0.43 T	% pg/g	JB	High	Datum is estimated, possible high bias; MSD recovery outside acceptance criteria Analyte detected in associated blank; sample concentration greater than five times the blank concentration
TS	TS-230206-0930 DRIED	02/23/06	SW-846 8290	1,2,3,4,7,8,9-Heptachlorodibenzofuran	2.5 T	pg/g	LB	0.47 T	pg/g	B	None	Analyte detected in associated blank; sample concentration greater than five times the blank concentration
TS	TS-230206-0930 DRIED	02/23/06	SW-846 8290	1,2,3,4,7,8-Hexachlorodibenzo-p-dioxin	0.71 T	pg/g	IAR	1	N/A	J	None	Datum is estimated, bias unknown; ion abundance ratio outside acceptance criteria
TS	TS-230206-0930 DRIED	02/23/06	SW-846 8290	1,2,3,4,7,8-Hexachlorodibenzofuran	7.6	pg/g	PDE LB	N/A 0.43 T	N/A pg/g	JB	None	Datum is estimated, bias unknown; interfering polychlorinated diphenyl ether peak present Analyte detected in associated blank; sample concentration greater than five times the blank concentration
TS	TS-230206-0930 DRIED	02/23/06	SW-846 8290	1,2,3,6,7,8-Hexachlorodibenzofuran	2.6 T	pg/g	LB	0.36 T	pg/g	B	None	Analyte detected in associated blank; sample concentration greater than five times the blank concentration
TS	TS-230206-0930 DRIED	02/23/06	SW-846 8290	1,2,3,7,8,9-Hexachlorodibenzo-p-Dioxin	1.8 T	pg/g	IAR LB	0.88 0.49 T	N/A pg/g	JUB	None	Datum is estimated, bias unknown; ion abundance ratio outside acceptance criteria Analyte considered not detected, analyte detected in associated blank; sample concentration less than five times the blank concentration
TS	TS-230206-0930 DRIED	02/23/06	SW-846 8290	1,2,3,7,8-Pentachlorodibenzo-p-dioxin	0.51 T	pg/g	IAR	0.81	N/A	J	None	Datum is estimated, bias unknown; ion abundance ratio outside acceptance criteria
TS	TS-230206-0930 DRIED	02/23/06	SW-846 8290	1,2,3,7,8-Pentachlorodibenzofuran	1.8 T	pg/g	IAR LB	1.3 0.39 T	N/A pg/g	JUB	None	Datum is estimated, bias unknown; ion abundance ratio outside acceptance criteria Analyte considered not detected, analyte detected in associated blank; sample concentration less than five times the blank concentration
TS	TS-230206-0930 DRIED	02/23/06	SW-846 8290	2,3,4,6,7,8-Hexachlorodibenzofuran	2.0 T	pg/g	LB	0.38 T	pg/g	B	None	Analyte detected in associated blank; sample concentration greater than five times the blank concentration
TS	TS-230206-0930 DRIED	02/23/06	SW-846 8290	2,3,4,7,8-Pentachlorodibenzofuran	3.0 T	pg/g	LB	0.26 T	pg/g	B	None	Analyte detected in associated blank; sample concentration greater than five times the blank concentration
TS	TS-230206-0930 DRIED	02/23/06	SW-846 8290	2,3,7,8-Tetrachlorodibenzo-p-dioxin	5.8	pg/g	MS MSD	440 152	%	J	High	Datum is estimated, possible high bias; MS/MSD recoveries outside acceptance criteria
TS	TS-230206-0930 DRIED	02/23/06	SW-846 8290	Octachlorodibenzo-p-dioxin	550	pg/g	MS MSD LB	0 539 1.8 T	% %	JB	Low	Datum is estimated, possible low bias; MS/MSD recoveries outside acceptance criteria Analyte detected in associated blank; sample concentration greater than five times blank concentration

TABLE 1
DATA QUALIFIERS SUMMARY TABLE
DEMONSTRATION TESTING AND FULL-SCALE OPERATION OF THE BIOGENESIS SEDIMENT DECONTAMINATION PROCESS, KEASBEY, NEW JERSEY
(Page99 of 188)

Location Identification	Sample Identification	Sample Date	Analysis	Analyte	Sample Result	Sample Units	QC Type	QC Result	QC Units	Qualifier	Bias	Comment
TS	TS-230206-0930 DRIED	02/23/06	SW-846 8290	Octachlorodibenzofuran	28	pg/g	MS LB	44 1 1 T	% pg/g	JB	Low	Datum is estimated, possible low bias; MS recovery outside acceptance criterion Analyte detected in associated blank; sample concentration greater than five times the blank concentration
TS	TS-230206-0930 DRIED	02/23/06	SW-846 8081A	Dieldrin	3 9	µg/kg	CONF	1000	%	J	None	Datum is estimated, bias unknown; %D between primary and secondary GC columns outside acceptance criterion
TS	TS-230206-0930 DRIED	02/23/06	SW-846 8081A	p,p'-DDD	51	µg/kg	CONF	317	%	J	None	Datum is estimated, bias unknown; %D between primary and secondary GC columns outside acceptance criterion
RS	RS-270206-1400	02/27/06	SW-846 8082	2,2',3,4,4',5,5'-Heptachlorobiphenyl	17 D	µg/kg	CONF	40 8	%	J	None	Datum is estimated, bias unknown; %D between primary and secondary GC columns outside acceptance criterion
RS	RS-270206-1400	02/27/06	SW-846 8082	2,2',3,4,5'-Pentachlorobiphenyl	13 D	µg/kg	CONF	1000	%	J	None	Datum is estimated, bias unknown; %D between primary and secondary GC columns outside acceptance criterion
RS	RS-270206-1400	02/27/06	SW-846 8082	2,2',3,5,5',6-Hexachlorobiphenyl	3 5 TD	µg/kg	CONF	514	%	J	None	Datum is estimated, bias unknown; %D between primary and secondary GC columns outside acceptance criterion
RS	RS-270206-1400	02/27/06	SW-846 8082	2-Chlorobiphenyl	42 TD	µg/kg	CONF	47 8	%	J	None	Datum is estimated, bias unknown; %D between primary and secondary GC columns outside acceptance criterion
RS	RS-270206-1400	02/27/06	SW-846 8270C	Fluoranthene	3000 D	µg/kg	LCS	116	%	J	High	Datum is estimated, possible high bias; LCS recovery outside acceptance criteria
RS	RS-270206-1400	02/27/06	SW-846 8290	1,2,3,4,7,8,9-Heptachlorodibenzofuran	27	pg/g	IAR	1 24	N/A	J	None	Datum is estimated, bias unknown; ion abundance ratio outside acceptance criteria
RS	RS-270206-1400	02/27/06	SW-846 8290	1,2,3,6,7,8-Hexachlorodibenzofuran	47	pg/g	PDE	N/A	N/A	J	None	Datum is estimated, bias unknown; interfering polychlorinated diphenyl ether peak present
RS	RS-270206-1400	02/27/06	SW-846 8290	1,2,3,7,8,9-Hexachlorodibenzofuran	3 1 T	pg/g	IAR	1 76	N/A	J	None	Datum is estimated, bias unknown; ion abundance ratio outside acceptance criteria
RS	RS-270206-1400	02/27/06	SW-846 8290	1,2,3,7,8-Pentachlorodibenzo-p-dioxin	7 6 T	pg/g	IAR	1 13	N/A	J	None	Datum is estimated, bias unknown; ion abundance ratio outside acceptance criteria
RS	RS-270206-1400	02/27/06	SW-846 8290	2,3,4,6,7,8-Hexachlorodibenzofuran	21	pg/g	PDE	N/A	N/A	J	None	Datum is estimated, bias unknown; interfering polychlorinated diphenyl ether peak present
RS	RS-270206-1400	02/27/06	SW-846 8290	Octachlorodibenzo-p-dioxin	7900	pg/g	LB	0 28 T	pg/g	B	None	Analyte detected in associated blank; sample concentration greater than five times the blank concentration
RS	RS-270206-1400	02/27/06	SW-846 8081A	Dieldrin	34	µg/kg	CONF	75	%	J	None	Datum is estimated, bias unknown; %D between primary and secondary GC columns outside acceptance criterion
RS	RS-270206-1400	02/27/06	SW-846 8081A	beta Endosulfan	35	µg/kg	CONF	101	%	J	None	Datum is estimated, bias unknown; %D between primary and secondary GC columns outside acceptance criterion
RS	RS-270206-1400	02/27/06	SW-846 8081A	Endrin	33	µg/kg	CONF	166	%	J	None	Datum is estimated, bias unknown; %D between primary and secondary GC columns outside acceptance criterion

TABLE 1
DATA QUALIFIERS SUMMARY TABLE
DEMONSTRATION TESTING AND FULL-SCALE OPERATION OF THE BIOGENESIS SEDIMENT DECONTAMINATION PROCESS, KEASBEY, NEW JERSEY
(Page100 of 188)

Location Identification	Sample Identification	Sample Date	Analysis	Analyte	Sample Result	Sample Units	QC Type	QC Result	QC Units	Qualifier	Bias	Comment
RS	RS-270206-1400	02/27/06	SW-846 8081A	Alpha-Chlordane	23	µg/kg	CONF	170	%	J	None	Datum is estimated, bias unknown; %D between primary and secondary GC columns outside acceptance criterion
RS	RS-270206-1400	02/27/06	SW-846 8081A	p,p'-DDD	100	µg/kg	CONF	327	%	J	None	Datum is estimated, bias unknown; %D between primary and secondary GC columns outside acceptance criterion
TS	TS-270206-1350	02/27/06	SW-846 6010B	Lead	151	mg/kg	SLD	10.5	%	J	None	Datum is estimated, bias unknown; serial dilution %D outside acceptance criterion
TS	TS-270206-1350	02/27/06	SW-846 6010B	Selenium	2.5	mg/kg	SLD	28.1	%	J	None	Datum is estimated, bias unknown; serial dilution %D outside acceptance criterion
TS	TS-270206-1350	02/27/06	SW-846 6010B	Zinc	233	mg/kg	SLD	12.8	%	J	None	Datum is estimated, bias unknown; serial dilution %D outside acceptance criterion
TS	TS-270206-1350	02/27/06	SW-846 8082	2,2',3,4,4',5,5'-Heptachlorobiphenyl	6.1 D	µg/kg	CONF	53.8	%	J	None	Datum is estimated, bias unknown; %D between primary and secondary GC columns outside acceptance criterion
TS	TS-270206-1350	02/27/06	SW-846 8082	2,2',3,4,5'-Pentachlorobiphenyl	5 D	µg/kg	CONF	1000	%	J	None	Datum is estimated, bias unknown; %D between primary and secondary GC columns outside acceptance criterion
TS	TS-270206-1350	02/27/06	SW-846 8082	2,2',3,5,5',6-Hexachlorobiphenyl	0.58 TD	µg/kg	CONF	971	%	J	None	Datum is estimated, bias unknown; %D between primary and secondary GC columns outside acceptance criterion
TS	TS-270206-1350	02/27/06	SW-846 8082	2,2',5,5'-Tetrachlorobiphenyl	21 D	µg/kg	CONF	59.1	%	J	None	Datum is estimated, bias unknown; %D between primary and secondary GC columns outside acceptance criterion
TS	TS-270206-1350	02/27/06	SW-846 8082	2,3-Dichlorobiphenyl	3.9 D	µg/kg	CONF	155	%	J	None	Datum is estimated, bias unknown; %D between primary and secondary GC columns outside acceptance criterion
TS	TS-270206-1350	02/27/06	SW-846 8082	2-Chlorobiphenyl	18 TD	µg/kg	CONF	163	%	J	None	Datum is estimated, bias unknown; %D between primary and secondary GC columns outside acceptance criterion
TS	TS-270206-1350	02/27/06	SW-846 8270C	2-Methylphenol (o-Cresol)	<1200 D	µg/kg	MS	42	%	UJ	Low	Possible false negative; MS recovery outside acceptance criteria
TS	TS-270206-1350	02/27/06	SW-846 8270C	Benzo(a)anthracene	1100 TD	µg/kg	MSD	53	%	J	Low	Datum is estimated, possible low bias; MSD recovery outside acceptance criteria
TS	TS-270206-1350	02/27/06	SW-846 8270C	Benzo(a)pyrene	900 TD	µg/kg	MSD	42	%	J	Low	Datum is estimated, possible low bias; MSD recovery outside acceptance criteria
TS	TS-270206-1350	02/27/06	SW-846 8270C	Benzo(b)fluoranthene	760 TD	µg/kg	MS MSD	43 27	%	J	Low	Datum is estimated, possible low bias; MS/MSD recoveries outside acceptance criteria
TS	TS-270206-1350	02/27/06	SW-846 8270C	Benzo(g,h,i)perylene	760 TD	µg/kg	MSD	30	%	J	Low	Datum is estimated, possible low bias; MSD recovery outside acceptance criteria
TS	TS-270206-1350	02/27/06	SW-846 8270C	Benzo(k)fluoranthene	370 TD	µg/kg	MSD	46	%	J	Low	Datum is estimated, possible low bias; MSD recovery outside acceptance criteria
TS	TS-270206-1350	02/27/06	SW-846 8270C	Dibenzo(a,h)anthracene	<1200 D	µg/kg	MSD	42	%	UJ	Low	Possible false negative; MSD recovery outside acceptance criteria

TABLE 1
DATA QUALIFIERS SUMMARY TABLE
DEMONSTRATION TESTING AND FULL-SCALE OPERATION OF THE BIOGENESIS SEDIMENT DECONTAMINATION PROCESS, KEASBEY, NEW JERSEY
(Page101 of 188)

Location Identification	Sample Identification	Sample Date	Analysis	Analyte	Sample Result	Sample Units	QC Type	QC Result	QC Units	Qualifier	Bias	Comment
TS	TS-270206-1350	02/27/06	SW-846 8270C	Fluoranthene	2400 D	µg/kg	LCS	116	%	J	High	Datum is estimated, possible high bias; LCS recovery outside acceptance criteria
TS	TS-270206-1350	02/27/06	SW-846 8270C	Hexachloroethane	<1200 D	µg/kg	MSD	40	%	UJ	Low	Possible false negative; MSD recovery outside acceptance criteria
TS	TS-270206-1350	02/27/06	SW-846 8270C	Indeno(1,2,3-c,d)pyrene	600 TD	µg/kg	MSD	42	%	J	Low	Datum is estimated, possible low bias; MSD recovery outside acceptance criteria
TS	TS-270206-1350	02/27/06	SW-846 8290	1,2,3,4,7,8,9-Heptachlorodibenzofuran	5 1 T	pg/g	PDE	N/A	N/A	J	None	Datum is estimated, bias unknown; interfering polychlorinated diphenyl ether peak present
TS	TS-270206-1350	02/27/06	SW-846 8290	1,2,3,4,7,8-Hexachlorodibenzofuran	30	pg/g	PDE	N/A	N/A	J	None	Datum is estimated, bias unknown; interfering polychlorinated diphenyl ether peak present
TS	TS-270206-1350	02/27/06	SW-846 8290	1,2,3,7,8-Pentachlorodibenzo-p-dioxin	1 4 T	pg/g	IAR	1 24	N/A	J	None	Datum is estimated, bias unknown; ion abundance ratio outside acceptance criteria
TS	TS-270206-1350	02/27/06	SW-846 8290	Octachlorodibenzo-p-dioxin	1200	pg/g	LB	0 28 T	pg/g	B	None	Analyte detected in associated blank; sample concentration greater than five times the blank concentration
TS	TS-270206-1350	02/27/06	SW-846 8081A	p,p'-DDT	130	µg/kg	CONF	178	%	J	None	Datum is estimated, bias unknown; %D between primary and secondary GC columns outside acceptance criterion
TS	TS-270206-1350 DRIED	02/27/06	SW-846 8082	2,2',3,4,4',5,5'-Heptachlorobiphenyl	6 1 D	µg/kg	CONF	44 3	%	J	None	Datum is estimated, bias unknown; %D between primary and secondary GC columns outside acceptance criterion
TS	TS-270206-1350 DRIED	02/27/06	SW-846 8082	2,2',3,4,5'-Pentachlorobiphenyl	5 D	µg/kg	CONF	1000	%	J	None	Datum is estimated, bias unknown; %D between primary and secondary GC columns outside acceptance criterion
TS	TS-270206-1350 DRIED	02/27/06	SW-846 8082	2,2',3,5,5',6-Hexachlorobiphenyl	0 64 TD	µg/kg	CONF	867	%	J	None	Datum is estimated, bias unknown; %D between primary and secondary GC columns outside acceptance criterion
TS	TS-270206-1350 DRIED	02/27/06	SW-846 8082	2,2',5,5'-Tetrachlorobiphenyl	19 D	µg/kg	CONF	51 6	%	J	None	Datum is estimated, bias unknown; %D between primary and secondary GC columns outside acceptance criterion
TS	TS-270206-1350 DRIED	02/27/06	SW-846 8082	2,3-Dichlorobiphenyl	3 2 D	µg/kg	CONF	163	%	J	None	Datum is estimated, bias unknown; %D between primary and secondary GC columns outside acceptance criterion
TS	TS-270206-1350 DRIED	02/27/06	SW-846 8082	2-Chlorobiphenyl	23 TD	µg/kg	CONF	78 1	%	J	None	Datum is estimated, bias unknown; %D between primary and secondary GC columns outside acceptance criterion
TS	TS-270206-1350 DRIED	02/27/06	SW-846 8270C	2-Methylphenol (o-Cresol)	<1200 D	µg/kg	MS	42	%	UJ	Low	Possible false negative; MS recovery outside acceptance criteria
TS	TS-270206-1350 DRIED	02/27/06	SW-846 8270C	Benzo(a)anthracene	1300 D	µg/kg	MSD	53	%	J	Low	Datum is estimated, possible low bias; MSD recovery outside acceptance criteria
TS	TS-270206-1350 DRIED	02/27/06	SW-846 8270C	Benzo(a)pyrene	990 TD	µg/kg	MSD	42	%	J	Low	Datum is estimated, possible low bias; MSD recovery outside acceptance criteria
TS	TS-270206-1350 DRIED	02/27/06	SW-846 8270C	Benzo(b)fluoranthene	850 TD	µg/kg	MS MSD	43 27	%	J	Low	Datum is estimated, possible low bias; MS/MSD recoveries outside acceptance criteria

TABLE 1
DATA QUALIFIERS SUMMARY TABLE
DEMONSTRATION TESTING AND FULL-SCALE OPERATION OF THE BIOGENESIS SEDIMENT DECONTAMINATION PROCESS, KEASBEY, NEW JERSEY
(Page102 of 188)

Location Identification	Sample Identification	Sample Date	Analysis	Analyte	Sample Result	Sample Units	QC Type	QC Result	QC Units	Qualifier	Bias	Comment
TS	TS-270206-1350 DRIED	02/27/06	SW-846 8270C	Benzo(g,h,i)perylene	710 TD	µg/kg	MSD	30	%	J	Low	Datum is estimated, possible low bias; MSD recovery outside acceptance criteria
TS	TS-270206-1350 DRIED	02/27/06	SW-846 8270C	Benzo(k)fluoranthene	390 TD	µg/kg	MSD	46	%	J	Low	Datum is estimated, possible low bias; MSD recovery outside acceptance criteria
TS	TS-270206-1350 DRIED	02/27/06	SW-846 8270C	Dibenz(a,h)anthracene	<1200 D	µg/kg	MSD	42	%	UJ	Low	Possible false negative; MSD recovery outside acceptance criteria
TS	TS-270206-1350 DRIED	02/27/06	SW-846 8270C	Fluoranthene	2700 D	µg/kg	LCS	116	%	J	High	Datum is estimated, possible high bias; LCS recovery outside acceptance criteria
TS	TS-270206-1350 DRIED	02/27/06	SW-846 8270C	Hexachloroethane	<1200 D	µg/kg	MSD	40	%	UJ	Low	Possible false negative; MSD recovery outside acceptance criteria
TS	TS-270206-1350 DRIED	02/27/06	SW-846 8270C	Indeno(1,2,3-c,d)pyrene	630 TD	µg/kg	MSD	42	%	J	Low	Datum is estimated, possible low bias; MSD recovery outside acceptance criteria
TS	TS-270206-1350 DRIED	02/27/06	SW-846 8290	1,2,3,4,7,8-Hexachlorodibenzofuran	20	pg/g	PDE	N/A	N/A	J	None	Datum is estimated, bias unknown; interfering polychlorinated diphenyl ether peak present
TS	TS-270206-1350 DRIED	02/27/06	SW-846 8290	1,2,3,7,8-Pentachlorodibenzofuran	2.5 T	pg/g	IAR	1.89	N/A	J	None	Datum is estimated, bias unknown; ion abundance ratio outside acceptance criteria
TS	TS-270206-1350 DRIED	02/27/06	SW-846 8290	Octachlorodibenzo-p-dioxin	1100	pg/g	LB	0.28 T	pg/g	B	None	Analyte detected in associated blank; sample concentration greater than five times the blank concentration
TS	TS-270206-1350 DRIED	02/27/06	SW-846 8290	Octachlorodibenzofuran	41	pg/g	IAR	0.73	N/A	J	None	Datum is estimated, bias unknown; ion abundance ratio outside acceptance criteria
TS	TS-270206-1350 DRIED	02/27/06	SW-846 8081A	Dieldrin	13	µg/kg	CONF	666	%	J	None	Datum is estimated, bias unknown; %D between primary and secondary GC columns outside acceptance criterion
TS	TS-270206-1350 DRIED	02/27/06	SW-846 8081A	beta Endosulfan	12	µg/kg	CONF	146	%	J	None	Datum is estimated, bias unknown; %D between primary and secondary GC columns outside acceptance criterion
TS	TS-270206-1350 DRIED	02/27/06	SW-846 8081A	Endrin	6.1	µg/kg	CONF	415	%	J	None	Datum is estimated, bias unknown; %D between primary and secondary GC columns outside acceptance criterion
TS	TS-270206-1350 DRIED	02/27/06	SW-846 8081A	Alpha-Chlordane	8.7	µg/kg	CONF	532	%	J	None	Datum is estimated, bias unknown; %D between primary and secondary GC columns outside acceptance criterion
TS	TS-270206-1350 DRIED	02/27/06	SW-846 8081A	p,p'-DDD	83	µg/kg	CONF	598	%	J	None	Datum is estimated, bias unknown; %D between primary and secondary GC columns outside acceptance criterion
TS	TS-270206-1630	02/27/06	SW-846 8082	2,2',3,4,4',5,5'-Heptachlorobiphenyl	6.9 D	µg/kg	CONF	52.6	%	J	None	Datum is estimated, bias unknown; %D between primary and secondary GC columns outside acceptance criterion
TS	TS-270206-1630	02/27/06	SW-846 8082	2,2',3,4,4',5'-Pentachlorobiphenyl	5.6 D	µg/kg	CONF	1000	%	J	None	Datum is estimated, bias unknown; %D between primary and secondary GC columns outside acceptance criterion

TABLE 1
DATA QUALIFIERS SUMMARY TABLE
DEMONSTRATION TESTING AND FULL-SCALE OPERATION OF THE BIOGENESIS SEDIMENT DECONTAMINATION PROCESS, KEASBEY, NEW JERSEY
(Page103 of 188)

Location Identification	Sample Identification	Sample Date	Analysis	Analyte	Sample Result	Sample Units	QC Type	QC Result	QC Units	Qualifier	Bias	Comment
TS	TS-270206-1630	02/27/06	SW-846 8082	2,2',3,5,5',6-Hexachlorobiphenyl	1 TD	µg/kg	CONF	631	%	J	None	Datum is estimated, bias unknown; %D between primary and secondary GC columns outside acceptance criterion
TS	TS-270206-1630	02/27/06	SW-846 8082	2,3-Dichlorobiphenyl	4 2 D	µg/kg	CONF	88 6	%	J	None	Datum is estimated, bias unknown; %D between primary and secondary GC columns outside acceptance criterion
TS	TS-270206-1630	02/27/06	SW-846 8082	2-Chlorobiphenyl	22 TD	µg/kg	CONF	83 8	%	J	None	Datum is estimated, bias unknown; %D between primary and secondary GC columns outside acceptance criterion
TS	TS-270206-1630	02/27/06	SW-846 8270C	2-Methylphenol (o-Cresol)	<1200 D	µg/kg	MS	42	%	UJ	Low	Possible false negative; MS recovery outside acceptance criteria
TS	TS-270206-1630	02/27/06	SW-846 8270C	Benzo(a)anthracene	1200 D	µg/kg	MSD	53	%	J	Low	Datum is estimated, possible low bias; MSD recovery outside acceptance criteria
TS	TS-270206-1630	02/27/06	SW-846 8270C	Benzo(a)pyrene	920 TD	µg/kg	MSD	42	%	J	Low	Datum is estimated, possible low bias; MSD recovery outside acceptance criteria
TS	TS-270206-1630	02/27/06	SW-846 8270C	Benzo(b)fluoranthene	790 TD	µg/kg	MS	43	%	J	Low	Datum is estimated, possible low bias; MS/MSD recoveries outside acceptance criteria
TS	TS-270206-1630	02/27/06	SW-846 8270C	Benzo(g,h,i)perylene	660 TD	µg/kg	MSD	30	%	J	Low	Datum is estimated, possible low bias; MSD recovery outside acceptance criteria
TS	TS-270206-1630	02/27/06	SW-846 8270C	Benzo(k)fluoranthene	360 TD	µg/kg	MSD	46	%	J	Low	Datum is estimated, possible low bias; MSD recovery outside acceptance criteria
TS	TS-270206-1630	02/27/06	SW-846 8270C	Dibenz(a,h)anthracene	150 TD	µg/kg	MSD	42	%	J	Low	Datum is estimated, possible low bias; MSD recovery outside acceptance criteria
TS	TS-270206-1630	02/27/06	SW-846 8270C	Fluoranthene	2400 D	µg/kg	LCS	116	%	J	High	Datum is estimated, possible high bias; LCS recovery outside acceptance criteria
TS	TS-270206-1630	02/27/06	SW-846 8270C	Hexachloroethane	<1200 D	µg/kg	MSD	40	%	UJ	Low	Possible false negative; MSD recovery outside acceptance criteria
TS	TS-270206-1630	02/27/06	SW-846 8270C	Indeno(1,2,3-c,d)pyrene	600 TD	µg/kg	MSD	42	%	J	Low	Datum is estimated, possible low bias; MSD recovery outside acceptance criteria
TS	TS-270206-1630	02/27/06	SW-846 8290	1,2,3,4,7,8-Hexachlorodibenzo-p-dioxin	1 8 T	pg/g	IAR	0 97	N/A	J	None	Datum is estimated, bias unknown; ion abundance ratio outside acceptance criteria
TS	TS-270206-1630	02/27/06	SW-846 8290	1,2,3,4,7,8-Hexachlorodibenzofuran	30	pg/g	PDE	N/A	N/A	J	None	Datum is estimated, bias unknown; interfering polychlorinated diphenyl ether peak present
TS	TS-270206-1630	02/27/06	SW-846 8290	1,2,3,7,8-Pentachlorodibenzofuran	3 1 T	pg/g	IAR	1 85	N/A	J	None	Datum is estimated, bias unknown; ion abundance ratio outside acceptance criteria
TS	TS-270206-1630	02/27/06	SW-846 8290	2,3,4,6,7,8-Hexachlorodibenzofuran	4 4 T	pg/g	PDE	N/A	N/A	J	None	Datum is estimated, bias unknown; interfering polychlorinated diphenyl ether peak present
TS	TS-270206-1630	02/27/06	SW-846 8290	Octachlorodibenzo-p-dioxin	1200	pg/g	LB	0 28 T	pg/g	B	None	Analyte detected in associated blank; sample concentration greater than five times the blank concentration

TABLE 1
DATA QUALIFIERS SUMMARY TABLE
DEMONSTRATION TESTING AND FULL-SCALE OPERATION OF THE BIOGENESIS SEDIMENT DECONTAMINATION PROCESS, KEASBEY, NEW JERSEY
(Page104 of 188)

Location Identification	Sample Identification	Sample Date	Analysis	Analyte	Sample Result	Sample Units	QC Type	QC Result	QC Units	Qualifier	Bias	Comment
TS	TS-270206-1630	02/27/06	SW-846 8081A	Dieldrin	16	µg/kg	CONF	345	%	J	None	Datum is estimated, bias unknown; %D between primary and secondary GC columns outside acceptance criterion
TS	TS-270206-1630	02/27/06	SW-846 8081A	Endrin	18	µg/kg	CONF	113	%	J	None	Datum is estimated, bias unknown; %D between primary and secondary GC columns outside acceptance criterion
TS	TS-270206-1630	02/27/06	SW-846 8081A	Alpha-Chlordane	14	µg/kg	CONF	239	%	J	None	Datum is estimated, bias unknown; %D between primary and secondary GC columns outside acceptance criterion
TS	TS-270206-1630	02/27/06	SW-846 8081A	Gamma-Chlordane	9.8	µg/kg	CONF	187	%	J	None	Datum is estimated, bias unknown; %D between primary and secondary GC columns outside acceptance criterion
TS	TS-270206-1630	02/27/06	SW-846 8081A	Aldrin	12	µg/kg	CONF	201	%	J	None	Datum is estimated, bias unknown; %D between primary and secondary GC columns outside acceptance criterion
TS	TS-270206-1630	02/27/06	SW-846 8081A	p,p'-DDD	72	µg/kg	CONF	550	%	J	None	Datum is estimated, bias unknown; %D between primary and secondary GC columns outside acceptance criterion
TS	TS-270206-1630 DRIED	02/27/06	SW-846 8082	2,2',3,4,4',5,5'-Heptachlorobiphenyl	7.2 D	µg/kg	CONF	47.3	%	J	None	Datum is estimated, bias unknown; %D between primary and secondary GC columns outside acceptance criterion
TS	TS-270206-1630 DRIED	02/27/06	SW-846 8082	2,2',3,4,5'-Pentachlorobiphenyl	6 D	µg/kg	CONF	1000	%	J	None	Datum is estimated, bias unknown; %D between primary and secondary GC columns outside acceptance criterion
TS	TS-270206-1630 DRIED	02/27/06	SW-846 8082	2,2',3,5,5',6-Hexachlorobiphenyl	1.2 TD	µg/kg	CONF	865	%	J	None	Datum is estimated, bias unknown; %D between primary and secondary GC columns outside acceptance criterion
TS	TS-270206-1630 DRIED	02/27/06	SW-846 8082	2,2',5,5'-Tetrachlorobiphenyl	21 D	µg/kg	CONF	45.6	%	J	None	Datum is estimated, bias unknown; %D between primary and secondary GC columns outside acceptance criterion
TS	TS-270206-1630 DRIED	02/27/06	SW-846 8082	2,3-Dichlorobiphenyl	4.3 D	µg/kg	CONF	57	%	J	None	Datum is estimated, bias unknown; %D between primary and secondary GC columns outside acceptance criterion
TS	TS-270206-1630 DRIED	02/27/06	SW-846 8082	2-Chlorobiphenyl	24 D	µg/kg	CONF	120	%	J	None	Datum is estimated, bias unknown; %D between primary and secondary GC columns outside acceptance criterion
TS	TS-270206-1630 DRIED	02/27/06	SW-846 8270C	2-Methylphenol (o-Cresol)	<1100 D	µg/kg	MS	42	%	UJ	Low	Possible false negative; MS recovery outside acceptance criteria
TS	TS-270206-1630 DRIED	02/27/06	SW-846 8270C	Benzo(a)anthracene	1200 D	µg/kg	MSD	53	%	J	Low	Datum is estimated, possible low bias; MSD recovery outside acceptance criteria
TS	TS-270206-1630 DRIED	02/27/06	SW-846 8270C	Benzo(a)pyrene	910 TD	µg/kg	MSD	42	%	J	Low	Datum is estimated, possible low bias; MSD recovery outside acceptance criteria
TS	TS-270206-1630 DRIED	02/27/06	SW-846 8270C	Benzo(b)fluoranthene	780 TD	µg/kg	MS MSD	43 27	%	J	Low	Datum is estimated, possible low bias; MS/MSD recoveries outside acceptance criteria
TS	TS-270206-1630 DRIED	02/27/06	SW-846 8270C	Benzo(g,h,i)perylene	590 TD	µg/kg	MSD	30	%	J	Low	Datum is estimated, possible low bias; MSD recovery outside acceptance criteria
TS	TS-270206-1630 DRIED	02/27/06	SW-846 8270C	Benzo(k)fluoranthene	330 TD	µg/kg	MSD	46	%	J	Low	Datum is estimated, possible low bias; MSD recovery outside acceptance criteria

TABLE 1
DATA QUALIFIERS SUMMARY TABLE
DEMONSTRATION TESTING AND FULL-SCALE OPERATION OF THE BIOGENESIS SEDIMENT DECONTAMINATION PROCESS, KEASBEY, NEW JERSEY
(Page105 of 188)

Location Identification	Sample Identification	Sample Date	Analysis	Analyte	Sample Result	Sample Units	QC Type	QC Result	QC Units	Qualifier	Bias	Comment
TS	TS-270206-1630 DRIED	02/27/06	SW-846 8270C	Dibenz(a,h)anthracene	150 TD	µg/kg	MSD	42	%	J	Low	Datum is estimated, possible low bias; MSD recovery outside acceptance criteria
TS	TS-270206-1630 DRIED	02/27/06	SW-846 8270C	Fluoranthene	2300 D	µg/kg	LCS	116	%	J	High	Datum is estimated, possible high bias; LCS recovery outside acceptance criteria
TS	TS-270206-1630 DRIED	02/27/06	SW-846 8270C	Hexachloroethane	<1100 D	µg/kg	MSD	40	%	UJ	Low	Possible false negative; MSD recovery outside acceptance criteria
TS	TS-270206-1630 DRIED	02/27/06	SW-846 8270C	Indeno(1,2,3-c,d)pyrene	560 TD	µg/kg	MSD	42	%	J	Low	Datum is estimated, possible low bias; MSD recovery outside acceptance criteria
TS	TS-270206-1630 DRIED	02/27/06	SW-846 8290	1,2,3,4,7,8-Hexachlorodibenzofuran	16	pg/g	PDE	N/A	N/A	J	None	Datum is estimated, bias unknown; interfering polychlorinated diphenyl ether peak present
TS	TS-270206-1630 DRIED	02/27/06	SW-846 8290	Octachlorodibenzo-p-dioxin	650	pg/g	LB	0 28 T	pg/g	B	None	Analyte detected in associated blank; sample concentration greater than five times the blank concentration
TS	TS-270206-1630 DRIED	02/27/06	SW-846 8081A	Dieldrin	15	µg/kg	CONF	270	%	J	None	Datum is estimated, bias unknown; %D between primary and secondary GC columns outside acceptance criterion
TS	TS-270206-1630 DRIED	02/27/06	SW-846 8081A	beta Endosulfan	16	µg/kg	CONF	96 1	%	J	None	Datum is estimated, bias unknown; %D between primary and secondary GC columns outside acceptance criterion
TS	TS-270206-1630 DRIED	02/27/06	SW-846 8081A	Endrin	15	µg/kg	CONF	141	%	J	None	Datum is estimated, bias unknown; %D between primary and secondary GC columns outside acceptance criterion
TS	TS-270206-1630 DRIED	02/27/06	SW-846 8081A	Alpha-Chlordane	11	µg/kg	CONF	254	%	J	None	Datum is estimated, bias unknown; %D between primary and secondary GC columns outside acceptance criterion
TS	TS-270206-1630 DRIED	02/27/06	SW-846 8081A	Gamma-Chlordane	7 8	µg/kg	CONF	236	%	J	None	Datum is estimated, bias unknown; %D between primary and secondary GC columns outside acceptance criterion
TS	TS-270206-1630 DRIED	02/27/06	SW-846 8081A	Aldrin	8 5	µg/kg	CONF	312	%	J	None	Datum is estimated, bias unknown; %D between primary and secondary GC columns outside acceptance criterion
TS	TS-270206-1630 DRIED	02/27/06	SW-846 8081A	p,p'-DDD	64	µg/kg	CONF	491	%	J	None	Datum is estimated, bias unknown; %D between primary and secondary GC columns outside acceptance criterion
RS	RS-280206-1700	02/28/06	SW-846 8082	2,2',3,4,4',5,5'-Heptachlorobiphenyl	11 D	µg/kg	CONF	49 2	%	J	None	Datum is estimated, bias unknown; %D between primary and secondary GC columns outside acceptance criterion
RS	RS-280206-1700	02/28/06	SW-846 8082	2,2',3,4,5'-Pentachlorobiphenyl	11 D	µg/kg	CONF	1000	%	J	None	Datum is estimated, bias unknown; %D between primary and secondary GC columns outside acceptance criterion
RS	RS-280206-1700	02/28/06	SW-846 8082	2,2',3,5,5',6-Hexachlorobiphenyl	1 1 TD	µg/kg	CONF	944	%	J	None	Datum is estimated, bias unknown; %D between primary and secondary GC columns outside acceptance criterion
RS	RS-280206-1700	02/28/06	SW-846 8082	2,2',5,5'-Tetrachlorobiphenyl	43 D	µg/kg	CONF	289	%	J	None	Datum is estimated, bias unknown; %D between primary and secondary GC columns outside acceptance criterion

TABLE 1
DATA QUALIFIERS SUMMARY TABLE
DEMONSTRATION TESTING AND FULL-SCALE OPERATION OF THE BIOGENESIS SEDIMENT DECONTAMINATION PROCESS, KEASBEY, NEW JERSEY
(Page106 of 188)

Location Identification	Sample Identification	Sample Date	Analysis	Analyte	Sample Result	Sample Units	QC Type	QC Result	QC Units	Qualifier	Bias	Comment
RS	RS-280206-1700	02/28/06	SW-846 8082	2,3-Dichlorobiphenyl	10 D	µg/kg	CONF	157	%	J	None	Datum is estimated, bias unknown; %D between primary and secondary GC columns outside acceptance criterion
RS	RS-280206-1700	02/28/06	SW-846 8082	2-Chlorobiphenyl	61 D	µg/kg	CONF	73.4	%	J	None	Datum is estimated, bias unknown; %D between primary and secondary GC columns outside acceptance criterion
RS	RS-280206-1700	02/28/06	SW-846 8270C	Fluoranthene	2100 TD	µg/kg	LCS	116	%	J	High	Datum is estimated, possible high bias; LCS recovery outside acceptance criteria
RS	RS-280206-1700	02/28/06	SW-846 8290	1,2,3,7,8-Pentachlorodibenzo-p-dioxin	7.4 T	pg/g	IAR	1.19	N/A	J	None	Datum is estimated, bias unknown; ion abundance ratio outside acceptance criteria
RS	RS-280206-1700	02/28/06	SW-846 8290	2,3,7,8-Tetrachlorodibenzofuran	28	pg/g	PDE	N/A	N/A	J	None	Datum is estimated, bias unknown; interfering polychlorinated diphenyl ether peak present
RS	RS-280206-1700	02/28/06	SW-846 8290	Octachlorodibenzo-p-dioxin	7900	pg/g	LB	0.28 T	pg/g	B	None	Analyte detected in associated blank; sample concentration greater than five times the blank concentration
RS	RS-280206-1700	02/28/06	SW-846 8081A	p,p'-DDD	540	µg/kg	CONF	317	%	J	None	Datum is estimated, bias unknown; %D between primary and secondary GC columns outside acceptance criterion
TS	TS-280206-1705	02/28/06	SW-846 8082	2,2',3,3',4,4',5,5',6-Nonachlorobiphenyl	1.7 TD	µg/kg	CONF	40.6	%	J	None	Datum is estimated, bias unknown; %D between primary and secondary GC columns outside acceptance criterion
TS	TS-280206-1705	02/28/06	SW-846 8082	2,2',3,4,4',5,5'-Heptachlorobiphenyl	5 D	µg/kg	CONF	41.5	%	J	None	Datum is estimated, bias unknown; %D between primary and secondary GC columns outside acceptance criterion
TS	TS-280206-1705	02/28/06	SW-846 8082	2,2',3,4,5'-Pentachlorobiphenyl	4.9 D	µg/kg	CONF	1000	%	J	None	Datum is estimated, bias unknown; %D between primary and secondary GC columns outside acceptance criterion
TS	TS-280206-1705	02/28/06	SW-846 8082	2,2',5,5'-Tetrachlorobiphenyl	19 D	µg/kg	CONF	486	%	J	None	Datum is estimated, bias unknown; %D between primary and secondary GC columns outside acceptance criterion
TS	TS-280206-1705	02/28/06	SW-846 8082	2,3-Dichlorobiphenyl	4.8 D	µg/kg	CONF	185	%	J	None	Datum is estimated, bias unknown; %D between primary and secondary GC columns outside acceptance criterion
TS	TS-280206-1705	02/28/06	SW-846 8082	2-Chlorobiphenyl	23 TD	µg/kg	CONF	190	%	J	None	Datum is estimated, bias unknown; %D between primary and secondary GC columns outside acceptance criterion
TS	TS-280206-1705	02/28/06	SW-846 8270C	Fluoranthene	2000 D	µg/kg	LCS	116	%	J	High	Datum is estimated, possible high bias; LCS recovery outside acceptance criteria
TS	TS-280206-1705	02/28/06	SW-846 8290	1,2,3,4,7,8,9-Heptachlorodibenzofuran	6.3 T	pg/g	IAR	1.23	N/A	J	None	Datum is estimated, bias unknown; ion abundance ratio outside acceptance criteria
TS	TS-280206-1705	02/28/06	SW-846 8290	1,2,3,4,7,8-Hexachlorodibenzo-p-dioxin	1.1 T	pg/g	IAR	0.52	N/A	J	None	Datum is estimated, bias unknown; ion abundance ratio outside acceptance criteria
TS	TS-280206-1705	02/28/06	SW-846 8290	1,2,3,4,7,8-Hexachlorodibenzofuran	23	pg/g	PDE	N/A	N/A	J	None	Datum is estimated, bias unknown; interfering polychlorinated diphenyl ether peak present
TS	TS-280206-1705	02/28/06	SW-846 8290	1,2,3,7,8-Pentachlorodibenzo-p-dioxin	1.7 T	pg/g	IAR	0.86	N/A	J	None	Datum is estimated, bias unknown; ion abundance ratio outside acceptance criteria

TABLE 1
DATA QUALIFIERS SUMMARY TABLE
DEMONSTRATION TESTING AND FULL-SCALE OPERATION OF THE BIOGENESIS SEDIMENT DECONTAMINATION PROCESS, KEASBEY, NEW JERSEY
(Page107 of 188)

Location Identification	Sample Identification	Sample Date	Analysis	Analyte	Sample Result	Sample Units	QC Type	QC Result	QC Units	Qualifier	Bias	Comment
TS	TS-280206-1705	02/28/06	SW-846 8290	2,3,7,8-Tetrachlorodibenzo-p-dioxin	20	pg/g	CMC	3	s	J	None	Datum is estimated, bias unknown; peaks comax outside acceptance criterion
TS	TS-280206-1705	02/28/06	SW-846 8290	Octachlorodibenzo-p-dioxin	1400	pg/g	LB	0.28 T	pg/g	B	None	Analyte detected in associated blank; sample concentration greater than five times the blank concentration
TS	TS-280206-1705	02/28/06	SW-846 8081A	p,p'-DDT	260	µg/kg	CONF	50.1	%	J	None	Datum is estimated, bias unknown; %D between primary and secondary GC columns outside acceptance criterion
WS	WS-280206-1710	02/28/06	SW-846 8082	2,2',3,4,4',5,5'-Heptachlorobiphenyl	16 D	µg/kg	CONF	49.6	%	J	None	Datum is estimated, bias unknown; %D between primary and secondary GC columns outside acceptance criterion
WS	WS-280206-1710	02/28/06	SW-846 8082	2,2',3,4,5'-Pentachlorobiphenyl	14 D	µg/kg	CONF	1000	%	J	None	Datum is estimated, bias unknown; %D between primary and secondary GC columns outside acceptance criterion
WS	WS-280206-1710	02/28/06	SW-846 8082	2,2',3,5,5',6-Hexachlorobiphenyl	1.4 TD	µg/kg	CONF	962	%	J	None	Datum is estimated, bias unknown; %D between primary and secondary GC columns outside acceptance criterion
WS	WS-280206-1710	02/28/06	SW-846 8082	2,2',5,5'-Tetrachlorobiphenyl	58 D	µg/kg	CONF	272	%	J	None	Datum is estimated, bias unknown; %D between primary and secondary GC columns outside acceptance criterion
WS	WS-280206-1710	02/28/06	SW-846 8082	2,3-Dichlorobiphenyl	14 D	µg/kg	CONF	124	%	J	None	Datum is estimated, bias unknown; %D between primary and secondary GC columns outside acceptance criterion
WS	WS-280206-1710	02/28/06	SW-846 8082	2-Chlorobiphenyl	98 D	µg/kg	CONF	41.1	%	J	None	Datum is estimated, bias unknown; %D between primary and secondary GC columns outside acceptance criterion
WS	WS-280206-1710	02/28/06	SW-846 8270C	Fluoranthene	1300 TD	µg/kg	LCS	116	%	J	High	Datum is estimated, possible high bias; LCS recovery outside acceptance criteria
WS	WS-280206-1710	02/28/06	SW-846 8290	1,2,3,4,7,8,9-Heptachlorodibenzofuran	4.9 T	pg/g	IAR	0.85	N/A	J	None	Datum is estimated, bias unknown; ion abundance ratio outside acceptance criteria
WS	WS-280206-1710	02/28/06	SW-846 8290	1,2,3,6,7,8-Hexachlorodibenzo-p-Dioxin	6.0 T	pg/g	IAR	1.56	N/A	J	None	Datum is estimated, bias unknown; ion abundance ratio outside acceptance criteria
WS	WS-280206-1710	02/28/06	SW-846 8290	2,3,4,6,7,8-Hexachlorodibenzofuran	4.5 T	pg/g	IAR	1.49	N/A	J	None	Datum is estimated, bias unknown; ion abundance ratio outside acceptance criteria
WS	WS-280206-1710	02/28/06	SW-846 8290	2,3,7,8-Tetrachlorodibenzofuran	6	pg/g	IAR	1.09	N/A	J	None	Datum is estimated, bias unknown; ion abundance ratio outside acceptance criteria
WS	WS-280206-1710	02/28/06	SW-846 8290	Octachlorodibenzo-p-dioxin	1400	pg/g	LB	0.28 T	pg/g	B	None	Analyte detected in associated blank; sample concentration greater than five times the blank concentration
WS	WS-280206-1710	02/28/06	SW-846 8081A	Endrin	78	µg/kg	CONF	789	%	J	None	Datum is estimated, bias unknown; %D between primary and secondary GC columns outside acceptance criterion
WS	WS-280206-1710	02/28/06	SW-846 8081A	Aldrin	24	µg/kg	CONF	356	%	J	None	Datum is estimated, bias unknown; %D between primary and secondary GC columns outside acceptance criterion

TABLE 1
DATA QUALIFIERS SUMMARY TABLE
DEMONSTRATION TESTING AND FULL-SCALE OPERATION OF THE BIOGENESIS SEDIMENT DECONTAMINATION PROCESS, KEASBEY, NEW JERSEY
(Page108 of 188)

Location Identification	Sample Identification	Sample Date	Analysis	Analyte	Sample Result	Sample Units	QC Type	QC Result	QC Units	Qualifier	Bias	Comment	
WS	WS-280206-1710	02/28/06	SW-846 8081A		p,p'-DDD	170	µg/kg	CONF	1000	%	J	None	Datum is estimated, bias unknown; %D between primary and secondary GC columns outside acceptance criterion
WS	WS-280206-1710	02/28/06	SW-846 8081A		p,p'-DDT	110	µg/kg	CONF	136	%	J	None	Datum is estimated, bias unknown; %D between primary and secondary GC columns outside acceptance criterion
RS	RS-010306-1700	03/01/06	SW-846 6010B		Lead	263	mg/kg	SLD	10.4	%	J	None	Datum is estimated, bias unknown; serial dilution %D outside acceptance criterion
RS	RS-010306-1700	03/01/06	SW-846 6010B		Selenium	2.8	mg/kg	SLD	100	%	J	None	Datum is estimated, bias unknown; serial dilution %D outside acceptance criterion
RS	RS-010306-1700	03/01/06	SW-846 6010B		Silver	4.6	mg/kg	SLD LB	11.1 0.046 T	% mg/kg	JB	None	Datum is estimated, bias unknown; serial dilution percent difference outside acceptance criterion Analyte detected in associated blank; sample concentration greater than five times the blank concentration
RS	RS-010306-1700	03/01/06	SW-846 6010B		Zinc	395	mg/kg	SLD LB	10.7 0.36 T	% mg/kg	JB	None	Datum is estimated, bias unknown; serial dilution percent difference outside acceptance criterion Analyte detected in associated blank; sample concentration greater than five times the blank concentration
RS	RS-010306-1700	03/01/06	SW-846 8082		2,2',3,4,4',5,5'-Heptachlorobiphenyl	18 D	µg/kg	CONF	46.2	%	J	None	Datum is estimated, bias unknown; %D between primary and secondary GC columns outside acceptance criterion
RS	RS-010306-1700	03/01/06	SW-846 8082		2,2',3,4,5'-Pentachlorobiphenyl	12 D	µg/kg	CONF	1000	%	J	None	Datum is estimated, bias unknown; %D between primary and secondary GC columns outside acceptance criterion
RS	RS-010306-1700	03/01/06	SW-846 8082		2,2',5,5'-Tetrachlorobiphenyl	44 D	µg/kg	CONF	326	%	J	None	Datum is estimated, bias unknown; %D between primary and secondary GC columns outside acceptance criterion
RS	RS-010306-1700	03/01/06	SW-846 8082		2,3-Dichlorobiphenyl	10 D	µg/kg	CONF	181	%	J	None	Datum is estimated, bias unknown; %D between primary and secondary GC columns outside acceptance criterion
RS	RS-010306-1700	03/01/06	SW-846 8082		2-Chlorobiphenyl	59 TD	µg/kg	CONF	1000	%	J	None	Datum is estimated, bias unknown; %D between primary and secondary GC columns outside acceptance criterion
RS	RS-010306-1700	03/01/06	SW-846 8290		1,2,3,4,7,8,9-Heptachlorodibenzofuran	16 T	pg/g	PDE LB	N/A 0.17 T	N/A pg/g	JB	None	Datum is estimated, bias unknown; interfering polychlorinated diphenyl ether peak present Analyte detected in associated blank; sample concentration greater than five times the blank concentration
RS	RS-010306-1700	03/01/06	SW-846 8290		1,2,3,4,7,8-Hexachlorodibenzofuran	48	pg/g	PDE	N/A	N/A	J	None	Datum is estimated, bias unknown; interfering polychlorinated diphenyl ether peak present
RS	RS-010306-1700	03/01/06	SW-846 8290		1,2,3,7,8,9-Hexachlorodibenzofuran	1.6 T	pg/g	IAR	0.89	N/A	J	None	Datum is estimated, bias unknown; ion abundance ratio outside acceptance criteria
RS	RS-010306-1700	03/01/06	SW-846 8290		1,2,3,7,8-Pentachlorodibenzo-p-dioxin	3.3 T	pg/g	IAR	1.15	N/A	J	None	Datum is estimated, bias unknown; ion abundance ratio outside acceptance criteria
RS	RS-010306-1700	03/01/06	SW-846 8290		Octachlorodibenzo-p-Dioxin	3200	pg/g	LB	0.58 T	pg/g	B	None	Analyte detected in associated blank; sample concentration greater than five times the blank concentration

TABLE 1
DATA QUALIFIERS SUMMARY TABLE
DEMONSTRATION TESTING AND FULL-SCALE OPERATION OF THE BIOGENESIS SEDIMENT DECONTAMINATION PROCESS, KEASBEY, NEW JERSEY
(Page109 of 188)

Location Identification	Sample Identification	Sample Date	Analysis	Analyte	Sample Result	Sample Units	QC Type	QC Result	QC Units	Qualifier	Bias	Comment
RS	RS-010306-1700	03/01/06	SW-846 8290	Octachlorodibenzofuran	300	pg/g	PDE LB	N/A 0.34 T	N/A pg/g	JB	None	Datum is estimated, bias unknown; interfering polychlorinated diphenyl ether peak present. Analyte detected in associated blank; sample concentration greater than five times the blank concentration.
RS	RS-010306-1700	03/01/06	SW-846 8081A	p,p'-DDD	65	µg/kg	CONF	1000	%	J	None	Datum is estimated, bias unknown; %D between primary and secondary GC columns outside acceptance criterion.
RS	RS-010306-1700	03/01/06	SW-846 8081A	p,p'-DDT	180	µg/kg	CONF	49.1	%	J	None	Datum is estimated, bias unknown; %D between primary and secondary GC columns outside acceptance criterion.
TS	TS-010306-1705	03/01/06	SW-846 6010B	Silver	2.6	mg/kg	LB	0.046 T	mg/kg	B	None	Analyte detected in associated blank; sample concentration greater than five times the blank concentration.
TS	TS-010306-1705	03/01/06	SW-846 6010B	Zinc	260	mg/kg	LB	0.36 T	mg/kg	B	None	Analyte detected in associated blank; sample concentration greater than five times the blank concentration.
TS	TS-010306-1705	03/01/06	SW-846 8082	2,2',3,4,4',5,5'-Heptachlorobiphenyl	7.9 D	µg/kg	CONF	45.1	%	J	None	Datum is estimated, bias unknown; %D between primary and secondary GC columns outside acceptance criterion.
TS	TS-010306-1705	03/01/06	SW-846 8082	2,2',3,4,5'-Pentachlorobiphenyl	7.8 D	µg/kg	CONF	1000	%	J	None	Datum is estimated, bias unknown; %D between primary and secondary GC columns outside acceptance criterion.
TS	TS-010306-1705	03/01/06	SW-846 8082	2,2',5,5'-Tetrachlorobiphenyl	34 D	µg/kg	CONF	400	%	J	None	Datum is estimated, bias unknown; %D between primary and secondary GC columns outside acceptance criterion.
TS	TS-010306-1705	03/01/06	SW-846 8082	2,3-Dichlorobiphenyl	9.6 D	µg/kg	CONF	124	%	J	None	Datum is estimated, bias unknown; %D between primary and secondary GC columns outside acceptance criterion.
TS	TS-010306-1705	03/01/06	SW-846 8082	2-Chlorobiphenyl	44 D	µg/kg	CONF	178	%	J	None	Datum is estimated, bias unknown; %D between primary and secondary GC columns outside acceptance criterion.
TS	TS-010306-1705	03/01/06	SW-846 8270C	Benzo(b)fluoranthene	670 TD	µg/kg	MS MSD	45 30	%	J	Low	Datum is estimated, possible low bias; MS/MSD recoveries outside acceptance criteria.
TS	TS-010306-1705	03/01/06	SW-846 8270C	Benzo(k)fluoranthene	260 TD	µg/kg	MS	51	%	J	Low	Datum is estimated, possible low bias; MS recovery outside acceptance criteria.
TS	TS-010306-1705	03/01/06	SW-846 8270C	Fluoranthene	1800 TD	µg/kg	MSD	41	%	J	Low	Datum is estimated, possible low bias; MSD recovery outside acceptance criteria.
TS	TS-010306-1705	03/01/06	SW-846 8270C	Hexachloroethane	<5200 D	µg/kg	MSD	40	%	UJ	Low	Possible false negative; MSD recovery outside acceptance criteria.
TS	TS-010306-1705	03/01/06	SW-846 8270C	Pentachlorophenol	<25000 D	µg/kg	MS MSD	0 0	%	UJ	Low	Possible false negative; MS/MSD recoveries outside acceptance criteria.
TS	TS-010306-1705	03/01/06	SW-846 8290	1,2,3,4,7,8,9-Heptachlorodibenzofuran	10	pg/g	LB	0.17 T	pg/g	B	None	Analyte detected in associated blank; sample concentration greater than five times the blank concentration.

TABLE 1
DATA QUALIFIERS SUMMARY TABLE
DEMONSTRATION TESTING AND FULL-SCALE OPERATION OF THE BIOGENESIS SEDIMENT DECONTAMINATION PROCESS, KEASBEY, NEW JERSEY
(Page 110 of 188)

Location Identification	Sample Identification	Sample Date	Analysis	Analyte	Sample Result	Sample Units	QC Type	QC Result	QC Units	Qualifier	Bias	Comment
TS	TS-010306-1705	03/01/06	SW-846 8290	2,3,7,8-Tetrachlorodibenzofuran	11	pg/g	IAR	0.91	N/A	J	None	Datum is estimated, bias unknown; ion abundance ratio outside acceptance criteria
TS	TS-010306-1705	03/01/06	SW-846 8290	Octachlorodibenzo-p-dioxin	2900	pg/g	LB	0.58 T	pg/g	B	None	Analyte detected in associated blank; sample concentration greater than five times the blank concentration
TS	TS-010306-1705	03/01/06	SW-846 8290	Octachlorodibenzofuran	200	pg/g	LB	0.34 T	pg/g	B	None	Analyte detected in associated blank; sample concentration greater than five times the blank concentration
TS	TS-010306-1705	03/01/06	SW-846 8081A	p,p'-DDD	66	µg/kg	CONF	1000	%	J	None	Datum is estimated, bias unknown; %D between primary and secondary GC columns outside acceptance criterion
TS	TS-010306-1705	03/01/06	SW-846 8081A	p,p'-DDT	140	µg/kg	CONF	77.6	%	J	None	Datum is estimated, bias unknown; %D between primary and secondary GC columns outside acceptance criterion
WS	WS-010306-1710	03/01/06	SW-846 6010B	Silver	9.2	mg/kg	LB	0.046 T	mg/kg	B	None	Analyte detected in associated blank; sample concentration greater than five times the blank concentration
WS	WS-010306-1710	03/01/06	SW-846 6010B	Zinc	703	mg/kg	LB	0.36 T	mg/kg	B	None	Analyte detected in associated blank; sample concentration greater than five times the blank concentration
WS	WS-010306-1710	03/01/06	SW-846 8082	2,2',3,4,4',5,5'-Heptachlorobiphenyl	14 D	µg/kg	CONF	48.9	%	J	None	Datum is estimated, bias unknown; %D between primary and secondary GC columns outside acceptance criterion
WS	WS-010306-1710	03/01/06	SW-846 8082	2,2',3,4,5'-Pentachlorobiphenyl	13 D	µg/kg	CONF	1000	%	J	None	Datum is estimated, bias unknown; %D between primary and secondary GC columns outside acceptance criterion
WS	WS-010306-1710	03/01/06	SW-846 8082	2,2',5,5'-Tetrachlorobiphenyl	49 D	µg/kg	CONF	244	%	J	None	Datum is estimated, bias unknown; %D between primary and secondary GC columns outside acceptance criterion
WS	WS-010306-1710	03/01/06	SW-846 8082	2,3-Dichlorobiphenyl	12 D	µg/kg	CONF	136	%	J	None	Datum is estimated, bias unknown; %D between primary and secondary GC columns outside acceptance criterion
WS	WS-010306-1710	03/01/06	SW-846 8082	2-Chlorobiphenyl	79 D	µg/kg	CONF	60.8	%	J	None	Datum is estimated, bias unknown; %D between primary and secondary GC columns outside acceptance criterion
WS	WS-010306-1710	03/01/06	SW-846 8290	1,2,3,4,7,8,9-Heptachlorodibenzofuran	5.2 T	pg/g	LB	0.17 T	pg/g	B	None	Analyte detected in associated blank; sample concentration greater than five times the blank concentration
WS	WS-010306-1710	03/01/06	SW-846 8290	1,2,3,4,7,8-Hexachlorodibenzo-p-dioxin	0.91 T	pg/g	IAR	0.93	N/A	J	None	Datum is estimated, bias unknown; ion abundance ratio outside acceptance criteria
WS	WS-010306-1710	03/01/06	SW-846 8290	1,2,3,4,7,8-Hexachlorodibenzofuran	14 T	pg/g	PDE	N/A	N/A	J	None	Datum is estimated, bias unknown; interfering polychlorinated diphenyl ether peak present
WS	WS-010306-1710	03/01/06	SW-846 8290	1,2,3,6,7,8-Hexachlorodibenzofuran	3.5 T	pg/g	IAR	1.48	N/A	J	None	Datum is estimated, bias unknown; ion abundance ratio outside acceptance criteria

TABLE 1
DATA QUALIFIERS SUMMARY TABLE
DEMONSTRATION TESTING AND FULL-SCALE OPERATION OF THE BIOGENESIS SEDIMENT DECONTAMINATION PROCESS, KEASBEY, NEW JERSEY
(Page 111 of 188)

Location Identification	Sample Identification	Sample Date	Analysis	Analyte	Sample Result	Sample Units	QC Type	QC Result	QC Units	Qualifier	Bias	Comment
WS	WS-010306-1710	03/01/06	SW-846 8290	1,2,3,7,8,9-Hexachlorodibenzo-p-Dioxin	2.7 T	pg/g	IAR	1.56	N/A	J	None	Datum is estimated, bias unknown; ion abundance ratio outside acceptance criteria
WS	WS-010306-1710	03/01/06	SW-846 8290	1,2,3,7,8-Pentachlorodibenzo-p-dioxin	0.73 T	pg/g	IAR	0.94	N/A	J	None	Datum is estimated, bias unknown; ion abundance ratio outside acceptance criteria
WS	WS-010306-1710	03/01/06	SW-846 8290	2,3,7,8-Tetrachlorodibenzofuran	4	pg/g	IAR	0.62	N/A	J	None	Datum is estimated, bias unknown; ion abundance ratio outside acceptance criteria
WS	WS-010306-1710	03/01/06	SW-846 8290	Octachlorodibenzo-p-dioxin	940	pg/g	LB	0.58 T	pg/g	B	None	Analyte detected in associated blank; sample concentration greater than five times the blank concentration
WS	WS-010306-1710	03/01/06	SW-846 8290	Octachlorodibenzofuran	73	pg/g	LB	0.34 T	pg/g	B	None	Analyte detected in associated blank; sample concentration greater than five times the blank concentration
WS	WS-010306-1710	03/01/06	SW-846 8081A	Dieldrin	6.7	µg/kg	CONF	1000	%	J	None	Datum is estimated, bias unknown; %D between primary and secondary GC columns outside acceptance criterion
WS	WS-010306-1710	03/01/06	SW-846 8081A	Alpha-Chlordane	5.3	µg/kg	CONF	955	%	J	None	Datum is estimated, bias unknown; %D between primary and secondary GC columns outside acceptance criterion
WS	WS-010306-1710	03/01/06	SW-846 8081A	Aldrin	2.8	µg/kg	CONF	601	%	J	None	Datum is estimated, bias unknown; %D between primary and secondary GC columns outside acceptance criterion
WS	WS-010306-1710	03/01/06	SW-846 8081A	p,p'-DDD	54	µg/kg	CONF	746	%	J	None	Datum is estimated, bias unknown; %D between primary and secondary GC columns outside acceptance criterion
WS	WS-010306-1710	03/01/06	SW-846 8081A	p,p'-DDT	24	µg/kg	CONF	138	%	J	None	Datum is estimated, bias unknown; %D between primary and secondary GC columns outside acceptance criterion
RS	RS-020306-1700	03/02/06	SW-846 6010B	Lead	303	mg/kg	MS	36	%	J	Low	Datum is estimated, possible low bias; MS recovery outside acceptance criteria
RS	RS-020306-1700	03/02/06	SW-846 6010B	Selenium	2.5	mg/kg	SLD	100	%	J	None	Datum is estimated, bias unknown; serial dilution %D outside acceptance criterion
RS	RS-020306-1700	03/02/06	SW-846 6010B	Silver	6	mg/kg	LB	0.030 T	mg/kg	B	None	Analyte detected in associated blank; sample concentration greater than five times the blank concentration
RS	RS-020306-1700	03/02/06	SW-846 6010B	Zinc	482	mg/kg	LB	0.33 T	mg/kg	B	None	Analyte detected in associated blank; sample concentration greater than five times the blank concentration
RS	RS-020306-1700	03/02/06	SW-846 8082	2,2',3,4,4',5,5'-Heptachlorobiphenyl	12 D	µg/kg	CONF	58.2	%	J	None	Datum is estimated, bias unknown; %D between primary and secondary GC columns outside acceptance criterion
RS	RS-020306-1700	03/02/06	SW-846 8082	2,2',3,4,5'-Pentachlorobiphenyl	10 D	µg/kg	CONF	1000	%	J	None	Datum is estimated, bias unknown; %D between primary and secondary GC columns outside acceptance criterion

TABLE 1
DATA QUALIFIERS SUMMARY TABLE
DEMONSTRATION TESTING AND FULL-SCALE OPERATION OF THE BIOGENESIS SEDIMENT DECONTAMINATION PROCESS, KEASBEY, NEW JERSEY
(Page 112 of 188)

Location Identification	Sample Identification	Sample Date	Analysis	Analyte	Sample Result	Sample Units	QC Type	QC Result	QC Units	Qualifier	Bias	Comment
RS	RS-020306-1700	03/02/06	SW-846 8082	2,2',5,5'-Tetrachlorobiphenyl	44 D	µg/kg	CONF	342	%	J	None	Datum is estimated, bias unknown; %D between primary and secondary GC columns outside acceptance criterion
RS	RS-020306-1700	03/02/06	SW-846 8082	2,3-Dichlorobiphenyl	10 D	µg/kg	CONF	150	%	J	None	Datum is estimated, bias unknown; %D between primary and secondary GC columns outside acceptance criterion
RS	RS-020306-1700	03/02/06	SW-846 8082	2-Chlorobiphenyl	67 TD	µg/kg	CONF LB	94 1 0 30 T	% µg/kg	JB	None	Datum is estimated, bias unknown; %D between primary and secondary GC columns outside acceptance criterion Analyte detected in associated blank; sample concentration greater than five times the blank concentration
RS	RS-020306-1700	03/02/06	SW-846 8290	1,2,3,4,7,8-Hexachlorodibenzo-p-dioxin	7 3 T	pg/g	IAR	1 47	N/A	J	None	Datum is estimated, bias unknown; ion abundance ratio outside acceptance criteria
RS	RS-020306-1700	03/02/06	SW-846 8290	1,2,3,4,7,8-Hexachlorodibenzofuran	74	pg/g	PDE	N/A	N/A	J	None	Datum is estimated, bias unknown; interfering polychlorinated diphenyl ether peak present
RS	RS-020306-1700	03/02/06	SW-846 8290	1,2,3,6,7,8-Hexachlorodibenzofuran	20	pg/g	IAR	1 45	N/A	J	None	Datum is estimated, bias unknown; ion abundance ratio outside acceptance criteria
RS	RS-020306-1700	03/02/06	SW-846 8290	1,2,3,7,8-Pentachlorodibenzo-p-dioxin	4 7 T	pg/g	IAR	1 13	N/A	J	None	Datum is estimated, bias unknown; ion abundance ratio outside acceptance criteria
RS	RS-020306-1700	03/02/06	SW-846 8290	2,3,4,7,8-Pentachlorodibenzofuran	23	pg/g	CMC	3	s	J	None	Datum is estimated, bias unknown; peaks comax outside acceptance criterion
RS	RS-020306-1700	03/02/06	SW-846 8290	Octachlorodibenzo-p-dioxin	7600	pg/g	LB	0 43 T	pg/g	B	None	Analyte detected in associated blank; sample concentration greater than five times the blank concentration
RS	RS-020306-1700	03/02/06	SW-846 8081A	Endrin	43	µg/kg	CONF	41 3	%	J	None	Datum is estimated, bias unknown; %D between primary and secondary GC columns outside acceptance criterion
RS	RS-020306-1700	03/02/06	SW-846 8081A	p,p'-DDD	110	µg/kg	CONF	1000	%	J	None	Datum is estimated, bias unknown; %D between primary and secondary GC columns outside acceptance criterion
RS	RS-020306-1700	03/02/06	SW-846 8081A	p,p'-DDT	74	µg/kg	CONF	233	%	J	None	Datum is estimated, bias unknown; %D between primary and secondary GC columns outside acceptance criterion
SS	SS-020306-1400	03/02/06	SW-846 6010B	Silver	1 5	mg/kg	LB	0 030 T	mg/kg	B	None	Analyte detected in associated blank; sample concentration greater than five times the blank concentration
SS	SS-020306-1400	03/02/06	SW-846 6010B	Zinc	186	mg/kg	LB	0 33 T	mg/kg	B	None	Analyte detected in associated blank; sample concentration greater than five times the blank concentration
SS	SS-020306-1400	03/02/06	SW-846 8082	2,2',3,3',4,4',5-Heptachlorobiphenyl	6 D	µg/kg	CONF	134	%	J	None	Datum is estimated, bias unknown; %D between primary and secondary GC columns outside acceptance criterion
SS	SS-020306-1400	03/02/06	SW-846 8082	2,2',3,4,4',5,5'-Heptachlorobiphenyl	8 1 D	µg/kg	CONF	42 9	%	J	None	Datum is estimated, bias unknown; %D between primary and secondary GC columns outside acceptance criterion

TABLE 1
DATA QUALIFIERS SUMMARY TABLE
DEMONSTRATION TESTING AND FULL-SCALE OPERATION OF THE BIOGENESIS SEDIMENT DECONTAMINATION PROCESS, KEASBEY, NEW JERSEY
(Page 113 of 188)

Location Identification	Sample Identification	Sample Date	Analysis	Analyte	Sample Result	Sample Units	QC Type	QC Result	QC Units	Qualifier	Bias	Comment
SS	SS-020306-1400	03/02/06	SW-846 8082	2,2',3,4,5'-Pentachlorobiphenyl	19 D	µg/kg	CONF	1000	%	J	None	Datum is estimated, bias unknown; %D between primary and secondary GC columns outside acceptance criterion
SS	SS-020306-1400	03/02/06	SW-846 8082	2,2',5,5'-Tetrachlorobiphenyl	83 D	µg/kg	CONF	1000	%	J	None	Datum is estimated, bias unknown; %D between primary and secondary GC columns outside acceptance criterion
SS	SS-020306-1400	03/02/06	SW-846 8082	2-Chlorobiphenyl	370 D	µg/kg	CONF LB	54.7 0.30 T	% µg/kg	JB	None	Datum is estimated, bias unknown; %D between primary and secondary GC columns outside acceptance criterion Analyte detected in associated blank; sample concentration greater than five times the blank concentration
SS	SS-020306-1400	03/02/06	SW-846 8290	1,2,3,4,7,8-Hexachlorodibenzofuran	27	pg/g	PDE	N/A	N/A	J	None	Datum is estimated, bias unknown; interfering polychlorinated diphenyl ether peak present
SS	SS-020306-1400	03/02/06	SW-846 8290	1,2,3,6,7,8-Hexachlorodibenzo-p-Dioxin	7.5 T	pg/g	IAR	0.95	N/A	J	None	Datum is estimated, bias unknown; ion abundance ratio outside acceptance criteria
SS	SS-020306-1400	03/02/06	SW-846 8290	1,2,3,7,8-Hexachlorodibenzo-p-Dioxin	4.6 T	pg/g	IAR	0.93	N/A	J	None	Datum is estimated, bias unknown; ion abundance ratio outside acceptance criteria
SS	SS-020306-1400	03/02/06	SW-846 8290	1,2,3,7,8-Pentachlorodibenzo-p-dioxin	1.7 T	pg/g	IAR	1.27	N/A	J	None	Datum is estimated, bias unknown; ion abundance ratio outside acceptance criteria
SS	SS-020306-1400	03/02/06	SW-846 8290	1,2,3,7,8-Pentachlorodibenzofuran	4.8 T	pg/g	IAR	1.81	N/A	J	None	Datum is estimated, bias unknown; ion abundance ratio outside acceptance criteria
SS	SS-020306-1400	03/02/06	SW-846 8290	2,3,7,8-Tetrachlorodibenzofuran	11	pg/g	IAR	0.64	N/A	J	None	Datum is estimated, bias unknown; ion abundance ratio outside acceptance criteria
SS	SS-020306-1400	03/02/06	SW-846 8290	Octachlorodibenzo-p-dioxin	1300	pg/g	LB	0.43 T	pg/g	B	None	Analyte detected in associated blank; sample concentration greater than five times the blank concentration
TS	TS-020306-1705	03/02/06	SW-846 6010B	Silver	3	mg/kg	LB	0.030 T	mg/kg	B	None	Analyte detected in associated blank; sample concentration greater than five times the blank concentration
TS	TS-020306-1705	03/02/06	SW-846 6010B	Zinc	282	mg/kg	LB	0.33 T	mg/kg	B	None	Analyte detected in associated blank; sample concentration greater than five times the blank concentration
TS	TS-020306-1705	03/02/06	SW-846 8082	2,2',3,4,4',5,5'-Heptachlorobiphenyl	5.8 D	µg/kg	CONF	53.4	%	J	None	Datum is estimated, bias unknown; %D between primary and secondary GC columns outside acceptance criterion
TS	TS-020306-1705	03/02/06	SW-846 8082	2,2',3,4,5'-Pentachlorobiphenyl	6.6 D	µg/kg	CONF	1000	%	J	None	Datum is estimated, bias unknown; %D between primary and secondary GC columns outside acceptance criterion
TS	TS-020306-1705	03/02/06	SW-846 8082	2,2',5,5'-Tetrachlorobiphenyl	23 D	µg/kg	CONF	408	%	J	None	Datum is estimated, bias unknown; %D between primary and secondary GC columns outside acceptance criterion
TS	TS-020306-1705	03/02/06	SW-846 8082	2,3-Dichlorobiphenyl	5.9 D	µg/kg	CONF	154	%	J	None	Datum is estimated, bias unknown; %D between primary and secondary GC columns outside acceptance criterion

TABLE 1
DATA QUALIFIERS SUMMARY TABLE
DEMONSTRATION TESTING AND FULL-SCALE OPERATION OF THE BIOGENESIS SEDIMENT DECONTAMINATION PROCESS, KEASBEY, NEW JERSEY
(Page 114 of 188)

Location Identification	Sample Identification	Sample Date	Analysis	Analyte	Sample Result	Sample Units	QC Type	QC Result	QC Units	Qualifier	Bias	Comment
TS	TS-020306-1705	03/02/06	SW-846 8082	2-Chlorobiphenyl	24 TD	µg/kg	CONF LB	200 0 30 T	% µg/kg	JB	None	Datum is estimated, bias unknown; %D between primary and secondary GC columns outside acceptance criterion Analyte detected in associated blank; sample concentration greater than five times the blank concentration
TS	TS-020306-1705	03/02/06	SW-846 8290	1,2,3,4,7,8-Hexachlorodibenzofuran	19	pg/g	PDE	N/A	N/A	J	None	Datum is estimated, bias unknown; interfering polychlorinated diphenyl ether peak present
TS	TS-020306-1705	03/02/06	SW-846 8290	2,3,7,8-Tetrachlorodibenzofuran	7 9	pg/g	PDE	N/A	N/A	J	None	Datum is estimated, bias unknown; interfering polychlorinated diphenyl ether peak present
TS	TS-020306-1705	03/02/06	SW-846 8290	Octachlorodibenzo-p-dioxin	1600	pg/g	LB	0 43 T	pg/g	B	None	Analyte detected in associated blank; sample concentration greater than five times the blank concentration
TS	TS-020306-1705	03/02/06	SW-846 8081A	p,p'-DDD	110	µg/kg	CONF	1000	%	J	None	Datum is estimated, bias unknown; %D between primary and secondary GC columns outside acceptance criterion
TS	TS-020306-1705	03/02/06	SW-846 8081A	p,p'-DDT	270	µg/kg	CONF	46 5	%	J	None	Datum is estimated, bias unknown; %D between primary and secondary GC columns outside acceptance criterion
WS	WS-020306-1710	03/02/06	SW-846 6010B	Silver	9 3	mg/kg	LB	0 030 T	mg/kg	B	None	Analyte detected in associated blank; sample concentration greater than five times the blank concentration
WS	WS-020306-1710	03/02/06	SW-846 6010B	Zinc	668	mg/kg	LB	0 33 T	mg/kg	B	None	Analyte detected in associated blank; sample concentration greater than five times the blank concentration
WS	WS-020306-1710	03/02/06	SW-846 8082	2,2',3,4,4',5,5'-Heptachlorobiphenyl	16 D	µg/kg	CONF	57 9	%	J	None	Datum is estimated, bias unknown; %D between primary and secondary GC columns outside acceptance criterion
WS	WS-020306-1710	03/02/06	SW-846 8082	2,2',3,4,5'-Pentachlorobiphenyl	15 D	µg/kg	CONF	1000	%	J	None	Datum is estimated, bias unknown; %D between primary and secondary GC columns outside acceptance criterion
WS	WS-020306-1710	03/02/06	SW-846 8082	2,2',5,5'-Tetrachlorobiphenyl	56 D	µg/kg	CONF	300	%	J	None	Datum is estimated, bias unknown; %D between primary and secondary GC columns outside acceptance criterion
WS	WS-020306-1710	03/02/06	SW-846 8082	2,3-Dichlorobiphenyl	14 D	µg/kg	CONF	146	%	J	None	Datum is estimated, bias unknown; %D between primary and secondary GC columns outside acceptance criterion
WS	WS-020306-1710	03/02/06	SW-846 8082	2-Chlorobiphenyl	56 TD	µg/kg	CONF LB	155 0 30 T	% µg/kg	JB	None	Datum is estimated, bias unknown; %D between primary and secondary GC columns outside acceptance criterion Analyte detected in associated blank; sample concentration greater than five times the blank concentration
WS	WS-020306-1710	03/02/06	SW-846 8270C	Benzo(g,h,i)perylene	170 TD	µg/kg	MS MSD	44 42	%	J	Low	Datum is estimated, possible low bias; MS/MSD recoveries outside acceptance criteria
WS	WS-020306-1710	03/02/06	SW-846 8270C	Hexachloroethane	<3100 D	µg/kg	MS MSD	24 25	%	UJ	Low	Possible false negative; MS/MSD recoveries outside acceptance criteria
WS	WS-020306-1710	03/02/06	SW-846 8270C	Indeno(1,2,3-c,d)pyrene	120 TD	µg/kg	MS MSD	47 46	%	J	Low	Datum is estimated, possible low bias; MS/MSD recoveries outside acceptance criteria

TABLE 1
DATA QUALIFIERS SUMMARY TABLE
DEMONSTRATION TESTING AND FULL-SCALE OPERATION OF THE BIOGENESIS SEDIMENT DECONTAMINATION PROCESS, KEASBEY, NEW JERSEY
(Page 115 of 188)

Location Identification	Sample Identification	Sample Date	Analysis	Analyte	Sample Result	Sample Units	QC Type	QC Result	QC Units	Qualifier	Bias	Comment
WS	WS-020306-1710	03/02/06	SW-846 8290	1,2,3,6,7,8-Hexachlorodibenzofuran	1.9 T	pg/g	IAR	1.54	N/A	J	None	Datum is estimated, bias unknown; ion abundance ratio outside acceptance criteria
WS	WS-020306-1710	03/02/06	SW-846 8290	1,2,3,7,8,9-Hexachlorodibenzo-p-Dioxin	1.6 T	pg/g	IAR	1.48	N/A	J	None	Datum is estimated, bias unknown; ion abundance ratio outside acceptance criteria
WS	WS-020306-1710	03/02/06	SW-846 8290	1,2,3,7,8-Pentachlorodibenzofuran	1.3 T	pg/g	IAR	1.17	N/A	J	None	Datum is estimated, bias unknown; ion abundance ratio outside acceptance criteria
WS	WS-020306-1710	03/02/06	SW-846 8290	2,3,4,6,7,8-Hexachlorodibenzofuran	1.4 T	pg/g	IAR	3.03	N/A	J	None	Datum is estimated, bias unknown; ion abundance ratio outside acceptance criteria
WS	WS-020306-1710	03/02/06	SW-846 8290	2,3,4,7,8-Pentachlorodibenzofuran	1.5 T	pg/g	IAR	1.18	N/A	J	None	Datum is estimated, bias unknown; ion abundance ratio outside acceptance criteria
WS	WS-020306-1710	03/02/06	SW-846 8290	2,3,7,8-Tetrachlorodibenzofuran	3.4 T	pg/g	IAR	0.97	N/A	J	None	Datum is estimated, bias unknown; ion abundance ratio outside acceptance criteria
WS	WS-020306-1710	03/02/06	SW-846 8290	Octachlorodibenzo-p-dioxin	430	pg/g	LB	0.43 T	pg/g	B	None	Analyte detected in associated blank; sample concentration greater than five times the blank concentration
WS	WS-020306-1710	03/02/06	SW-846 8081A	Endrin	43	µg/kg	CONF	40.6	%	J	None	Datum is estimated, bias unknown; %D between primary and secondary GC columns outside acceptance criterion
WS	WS-020306-1710	03/02/06	SW-846 8081A	p,p'-DDD	130	µg/kg	CONF	1000	%	J	None	Datum is estimated, bias unknown; %D between primary and secondary GC columns outside acceptance criterion
RS	RS-030306-1200	03/03/06	SW-846 6010B	Lead	285	mg/kg	MS	134	%	J	High	Datum is estimated, possible high bias; MS recovery outside acceptance criteria
RS	RS-030306-1200	03/03/06	SW-846 6010B	Zinc	456	mg/kg	MS LB	157 0.25 T	% mg/kg	JB	High	Datum is estimated, possible high bias; MS recovery outside acceptance criteria. Analyte detected in associated blank; sample concentration greater than five times the blank concentration
RS	RS-030306-1200	03/03/06	SW-846 8082	2,2',3,4,4',5,5'-Heptachlorobiphenyl	8.6 D	µg/kg	CONF	64.8	%	J	None	Datum is estimated, bias unknown; %D between primary and secondary GC columns outside acceptance criterion
RS	RS-030306-1200	03/03/06	SW-846 8082	2,2',3,4,5'-Pentachlorobiphenyl	8.4 D	µg/kg	CONF	1000	%	J	None	Datum is estimated, bias unknown; %D between primary and secondary GC columns outside acceptance criterion
RS	RS-030306-1200	03/03/06	SW-846 8082	2,2',3,4,5,5'-Hexachlorobiphenyl	4.2 TD	µg/kg	CONF	97.4	%	J	None	Datum is estimated, bias unknown; %D between primary and secondary GC columns outside acceptance criterion
RS	RS-030306-1200	03/03/06	SW-846 8082	2,2',5,5'-Tetrachlorobiphenyl	31 D	µg/kg	CONF	323	%	J	None	Datum is estimated, bias unknown; %D between primary and secondary GC columns outside acceptance criterion
RS	RS-030306-1200	03/03/06	SW-846 8082	2,3-Dichlorobiphenyl	11 D	µg/kg	CONF	73.7	%	J	None	Datum is estimated, bias unknown; %D between primary and secondary GC columns outside acceptance criterion
RS	RS-030306-1200	03/03/06	SW-846 8290	1,2,3,4,7,8-Hexachlorodibenzofuran	75	pg/g	PDE	N/A	N/A	J	None	Datum is estimated, bias unknown; interfering polychlorinated diphenyl ether peak present

TABLE 1
DATA QUALIFIERS SUMMARY TABLE
DEMONSTRATION TESTING AND FULL-SCALE OPERATION OF THE BIOGENESIS SEDIMENT DECONTAMINATION PROCESS, KEASBEY, NEW JERSEY
(Page 116 of 188)

Location Identification	Sample Identification	Sample Date	Analysis	Analyte	Sample Result	Sample Units	QC Type	QC Result	QC Units	Qualifier	Bias	Comment
RS	RS-030306-1200	03/03/06	SW-846 8290	2,3,4,6,7,8-Hexachlorodibenzofuran	17	pg/g	IAR	0 91	N/A	J	None	Datum is estimated, bias unknown; ion abundance ratio outside acceptance criteria
RS	RS-030306-1200	03/03/06	SW-846 8290	2,3,7,8-Tetrachlorodibenzofuran	23	pg/g	PDE	N/A	N/A	J	None	Datum is estimated, bias unknown; interfering polychlorinated diphenyl ether peak present
RS	RS-030306-1200	03/03/06	SW-846 8290	Octachlorodibenzo-p-dioxin	6600	pg/g	MS LB	0 0 34 T	% pg/g	JB	Low	Datum is estimated, possible low bias; MS recovery outside acceptance criterion Analyte detected in associated blank; sample concentration greater than five times the blank concentration
RS	RS-030306-1200	03/03/06	SW-846 8081A	p,p'-DDD	33	µg/kg	CONF	1000	%	J	None	Datum is estimated, bias unknown; %D between primary and secondary GC columns outside acceptance criterion
RS	RS-030306-1200	03/03/06	SW-846 8081A	p,p'-DDT	47	µg/kg	CONF	117	%	J	None	Datum is estimated, bias unknown; %D between primary and secondary GC columns outside acceptance criterion
TS	TS-030306-1205	03/03/06	SW-846 6010B	Zinc	302	mg/kg	LB	0 25 T	mg/kg	B	None	Analyte detected in associated blank; sample concentration greater than five times the blank concentration
TS	TS-030306-1205	03/03/06	SW-846 8082	2,2',3,4,4',5,5'-Heptachlorobiphenyl	5 D	µg/kg	CONF	82 5	%	J	None	Datum is estimated, bias unknown; %D between primary and secondary GC columns outside acceptance criterion
TS	TS-030306-1205	03/03/06	SW-846 8082	2,2',3,4,5'-Pentachlorobiphenyl	5 1 D	µg/kg	CONF	1000	%	J	None	Datum is estimated, bias unknown; %D between primary and secondary GC columns outside acceptance criterion
TS	TS-030306-1205	03/03/06	SW-846 8082	2,2',5,5'-Tetrachlorobiphenyl	20 D	µg/kg	CONF	408	%	J	None	Datum is estimated, bias unknown; %D between primary and secondary GC columns outside acceptance criterion
TS	TS-030306-1205	03/03/06	SW-846 8082	2,3-Dichlorobiphenyl	5 1 D	µg/kg	CONF	130	%	J	None	Datum is estimated, bias unknown; %D between primary and secondary GC columns outside acceptance criterion
TS	TS-030306-1205	03/03/06	SW-846 8082	2-Chlorobiphenyl	30 D	µg/kg	CONF	71	%	J	None	Datum is estimated, bias unknown; %D between primary and secondary GC columns outside acceptance criterion
TS	TS-030306-1205	03/03/06	SW-846 8270C	Benzo(g,h,i)perylene	390 TD	µg/kg	MS MSD	43 45	%	J	Low	Datum is estimated, possible low bias; MS/MSD recoveries outside acceptance criteria
TS	TS-030306-1205	03/03/06	SW-846 8270C	Hexachloroethane	<2800 D	µg/kg	MS MSD	25 22	%	UJ	Low	Possible false negative; MS/MSD recoveries outside acceptance criteria
TS	TS-030306-1205	03/03/06	SW-846 8270C	Indeno(1,2,3-c,d)pyrene	310 TD	µg/kg	MS MSD	49 49	%	J	Low	Datum is estimated, possible low bias; MS/MSD recoveries outside acceptance criteria
TS	TS-030306-1205	03/03/06	SW-846 8290	1,2,3,4,7,8-Hexachlorodibenzo-p-dioxin	2 0 T	pg/g	IAR	1 55	N/A	J	None	Datum is estimated, bias unknown; ion abundance ratio outside acceptance criteria
TS	TS-030306-1205	03/03/06	SW-846 8290	1,2,3,4,7,8-Hexachlorodibenzofuran	27	pg/g	PDE	N/A	N/A	J	None	Datum is estimated, bias unknown; interfering polychlorinated diphenyl ether peak present
TS	TS-030306-1205	03/03/06	SW-846 8290	1,2,3,7,8-Pentachlorodibenzofuran	3 9 T	pg/g	IAR	1 93	N/A	J	None	Datum is estimated, bias unknown; ion abundance ratio outside acceptance criteria
TS	TS-030306-1205	03/03/06	SW-846 8290	Octachlorodibenzo-p-dioxin	2100	pg/g	LB	0 34 T	pg/g	B	None	Analyte detected in associated blank; sample concentration greater than five times the blank concentration

TABLE 1
DATA QUALIFIERS SUMMARY TABLE
DEMONSTRATION TESTING AND FULL-SCALE OPERATION OF THE BIOGENESIS SEDIMENT DECONTAMINATION PROCESS, KEASBEY, NEW JERSEY
(Page 117 of 188)

Location Identification	Sample Identification	Sample Date	Analysis	Analyte	Sample Result	Sample Units	QC Type	QC Result	QC Units	Qualifier	Bias	Comment
TS	TS-030306-1205	03/03/06	SW-846 8081A	beta Endosulfan	41	µg/kg	CONF	89.9	%	J	None	Datum is estimated, bias unknown; %D between primary and secondary GC columns outside acceptance criterion
TS	TS-030306-1205	03/03/06	SW-846 8081A	p,p'-DDD	93	µg/kg	CONF	979	%	J	None	Datum is estimated, bias unknown; %D between primary and secondary GC columns outside acceptance criterion
WS	WS-030306-1210	03/03/06	SW-846 6010B	Zinc	642	mg/kg	LB	0.25 T	mg/kg	B	None	Analyte detected in associated blank; sample concentration greater than five times the blank concentration
WS	WS-030306-1210	03/03/06	SW-846 8082	2,2',3,4,4',5,5'-Heptachlorobiphenyl	7.9 D	µg/kg	CONF	58.9	%	J	None	Datum is estimated, bias unknown; %D between primary and secondary GC columns outside acceptance criterion
WS	WS-030306-1210	03/03/06	SW-846 8082	2,2',3,4,5'-Pentachlorobiphenyl	7.9 D	µg/kg	CONF	1000	%	J	None	Datum is estimated, bias unknown; %D between primary and secondary GC columns outside acceptance criterion
WS	WS-030306-1210	03/03/06	SW-846 8082	2,2',5,5'-Tetrachlorobiphenyl	30 D	µg/kg	CONF	269	%	J	None	Datum is estimated, bias unknown; %D between primary and secondary GC columns outside acceptance criterion
WS	WS-030306-1210	03/03/06	SW-846 8082	2,3-Dichlorobiphenyl	6.4 D	µg/kg	CONF	149	%	J	None	Datum is estimated, bias unknown; %D between primary and secondary GC columns outside acceptance criterion
WS	WS-030306-1210	03/03/06	SW-846 8290	1,2,3,4,7,8,9-Heptachlorodibenzofuran	2.1 T	pg/g	IAR	1.25	N/A	J	None	Datum is estimated, bias unknown; ion abundance ratio outside acceptance criteria
WS	WS-030306-1210	03/03/06	SW-846 8290	1,2,3,6,7,8-Hexachlorodibenzo-p-Dioxin	2.5 T	pg/g	IAR	0.9	N/A	J	None	Datum is estimated, bias unknown; ion abundance ratio outside acceptance criteria
WS	WS-030306-1210	03/03/06	SW-846 8290	1,2,3,6,7,8-Hexachlorodibenzofuran	3.4 T	pg/g	IAR	0.99	N/A	J	None	Datum is estimated, bias unknown; ion abundance ratio outside acceptance criteria
WS	WS-030306-1210	03/03/06	SW-846 8290	2,3,7,8-Tetrachlorodibenzofuran	2.3 T	pg/g	IAR	0.97	N/A	J	None	Datum is estimated, bias unknown; ion abundance ratio outside acceptance criteria
WS	WS-030306-1210	03/03/06	SW-846 8290	Octachlorodibenzo-p-dioxin	710	pg/g	LB	0.34 T	pg/g	B	None	Analyte detected in associated blank; sample concentration greater than five times the blank concentration
WS	WS-030306-1210	03/03/06	SW-846 8081A	p,p'-DDD	38	µg/kg	CONF	1000	%	J	None	Datum is estimated, bias unknown; %D between primary and secondary GC columns outside acceptance criterion
SCALPING SCREEN	SCALPING SCREEN	03/16/06	Lloyd Kahn	Total organic carbon	200000	mg/kg	LB	565	mg/kg	B	None	Analyte detected in associated blank; sample concentration greater than five times the blank concentration
SEC SCREEN	SEC SCREEN-EFFLUENT	03/16/06	Lloyd Kahn	Total organic carbon	59800	mg/kg	LB	565	mg/kg	B	None	Analyte detected in associated blank; sample concentration greater than five times the blank concentration
SEC SCREEN	SEC SCREEN-INFLUENT	03/16/06	Lloyd Kahn	Total organic carbon	59500	mg/kg	LB	565	mg/kg	B	None	Analyte detected in associated blank; sample concentration greater than five times the blank concentration

TABLE 1
DATA QUALIFIERS SUMMARY TABLE
DEMONSTRATION TESTING AND FULL-SCALE OPERATION OF THE BIOGENESIS SEDIMENT DECONTAMINATION PROCESS, KEASBEY, NEW JERSEY
(Page 118 of 188)

Location Identification	Sample Identification	Sample Date	Analysis	Analyte	Sample Result	Sample Units	QC Type	QC Result	QC Units	Qualifier	Bias	Comment
SEC SCREEN	SEC SCREEN-INFLUENT	03/16/06	SW-846 6010B	Lead	420	mg/kg	MS MSD	459 490	%	J	High	Datum is estimated, possible high bias; MS/MSD recoveries outside acceptance criteria
SEC SCREEN	SEC SCREEN-SCREENINGS	03/16/06	Lloyd Kahn	Total organic carbon	225000	mg/kg	LB	565	mg/kg	B	None	Analyte detected in associated blank; sample concentration greater than five times the blank concentration
PSS	PSS-210306-0915	03/21/06	SW-846 6010B	Chromium, total	120	mg/kg	MS	167	%	J	High	Datum is estimated, possible high bias; MS recovery outside acceptance criteria
PSS	PSS-210306-0915	03/21/06	SW-846 6010B	Selenium	2.1	mg/kg	SLD	100	%	J	None	Datum is estimated, bias unknown; serial dilution %D outside acceptance criterion
PSS	PSS-210306-0915	03/21/06	SW-846 6010B	Zinc	316	mg/kg	MS	241	%	J	High	Datum is estimated, possible high bias; MS recovery outside acceptance criteria
PSS	PSS-210306-0915-AD	03/21/06	SW-846 8270 SIM	Benzo(g,h,i)perylene	1500 D	µg/kg	CVS	25.9	%	J	None	Datum is estimated, bias unknown; CVS %D outside acceptance criterion
PSS	PSS-210306-0915-AD	03/21/06	SW-846 8270 SIM	Dibenz(a,h)anthracene	430 D	µg/kg	LCS LCSD CVS	135 156 30.4	%	J	High	Datum is estimated, possible high bias; LCS/LCSD recoveries and CVS %D outside acceptance criteria
PSS	PSS-210306-0915-AD	03/21/06	SW-846 8270 SIM	Indeno(1,2,3-c,d)pyrene	1300 D	µg/kg	LCS LCSD CVS	118 135 27.5	%	J	High	Datum is estimated, possible high bias; LCS/LCSD recoveries and CVS %D outside acceptance criteria
RS	RS-210306-0930-AD	03/21/06	SW-846 8270 SIM	Benzo(g,h,i)perylene	1100 D	µg/kg	CVS	25.9	%	J	None	Datum is estimated, bias unknown; CVS %D outside acceptance criterion
RS	RS-210306-0930-AD	03/21/06	SW-846 8270 SIM	Dibenz(a,h)anthracene	320 D	µg/kg	LCS LCSD CVS	135 156 30.4	%	J	High	Datum is estimated, possible high bias; LCS/LCSD recoveries and CVS %D outside acceptance criteria
RS	RS-210306-0930-AD	03/21/06	SW-846 8270 SIM	Indeno(1,2,3-c,d)pyrene	890 D	µg/kg	LCS LCSD CVS	118 135 27.5	%	J	High	Datum is estimated, possible high bias; LCS/LCSD recoveries and CVS %D outside acceptance criteria
RS	RS-210306-0930-RR2	03/21/06	SW-846 8270 SIM	Acenaphthene	230 D	µg/kg	HT	16	days	J	Low	Datum is estimated; potentially biased low Preparation holding time exceeded
RS	RS-210306-0930-RR2	03/21/06	SW-846 8270 SIM	Acenaphthylene	350 D	µg/kg	HT	16	days	J	Low	Datum is estimated; potentially biased low Preparation holding time exceeded
RS	RS-210306-0930-RR2	03/21/06	SW-846 8270 SIM	Anthracene	670 D	µg/kg	HT	16	days	J	Low	Datum is estimated; potentially biased low Preparation holding time exceeded
RS	RS-210306-0930-RR2	03/21/06	SW-846 8270 SIM	Benzo(a)anthracene	1200 D	µg/kg	HT	16	days	J	Low	Datum is estimated; potentially biased low Preparation holding time exceeded
RS	RS-210306-0930-RR2	03/21/06	SW-846 8270 SIM	Benzo(a)pyrene	1300 D	µg/kg	HT	16	days	J	Low	Datum is estimated; potentially biased low Preparation holding time exceeded
RS	RS-210306-0930-RR2	03/21/06	SW-846 8270 SIM	Benzo(b)fluoranthene	1300 D	µg/kg	HT	16	days	J	Low	Datum is estimated; potentially biased low Preparation holding time exceeded

TABLE 1
DATA QUALIFIERS SUMMARY TABLE
DEMONSTRATION TESTING AND FULL-SCALE OPERATION OF THE BIOGENESIS SEDIMENT DECONTAMINATION PROCESS, KEASBEY, NEW JERSEY
(Page 119 of 188)

Location Identification	Sample Identification	Sample Date	Analysis	Analyte	Sample Result	Sample Units	QC Type	QC Result	QC Units	Qualifier	Bias	Comment
RS	RS-210306-0930-RR2	03/21/06	SW-846 8270 SIM	Benzo(g,h,i)perylene	830 D	µg/kg	HT	16	days	J	Low	Datum is estimated; potentially biased low Preparation holding time exceeded
RS	RS-210306-0930-RR2	03/21/06	SW-846 8270 SIM	Benzo(k)fluoranthene	560 D	µg/kg	HT	16	days	J	Low	Datum is estimated; potentially biased low Preparation holding time exceeded
RS	RS-210306-0930-RR2	03/21/06	SW-846 8270 SIM	Chrysene	1500 D	µg/kg	HT	16	days	J	Low	Datum is estimated; potentially biased low Preparation holding time exceeded
RS	RS-210306-0930-RR2	03/21/06	SW-846 8270 SIM	Dibenz(a,h)anthracene	210 D	µg/kg	HT	16	days	J	Low	Datum is estimated; potentially biased low Preparation holding time exceeded
RS	RS-210306-0930-RR2	03/21/06	SW-846 8270 SIM	Fluoranthene	2000 D	µg/kg	HT	16	days	J	Low	Datum is estimated; potentially biased low Preparation holding time exceeded
RS	RS-210306-0930-RR2	03/21/06	SW-846 8270 SIM	Fluorene	200 D	µg/kg	HT	16	days	J	Low	Datum is estimated; potentially biased low Preparation holding time exceeded
RS	RS-210306-0930-RR2	03/21/06	SW-846 8270 SIM	Indeno(1,2,3-c,d)pyrene	690 D	µg/kg	HT	16	days	J	Low	Datum is estimated; potentially biased low Preparation holding time exceeded
RS	RS-210306-0930-RR2	03/21/06	SW-846 8270 SIM	Naphthalene	320 D	µg/kg	HT	16	days	J	Low	Datum is estimated; potentially biased low Preparation holding time exceeded
RS	RS-210306-0930-RR2	03/21/06	SW-846 8270 SIM	Phenanthrene	1000 D	µg/kg	HT	16	days	J	Low	Datum is estimated; potentially biased low Preparation holding time exceeded
RS	RS-210306-0930-RR2	03/21/06	SW-846 8270 SIM	Pyrene	2500 D	µg/kg	HT	16	days	J	Low	Datum is estimated; potentially biased low Preparation holding time exceeded
RS	RS-210306-0930-RR2-DUP	03/21/06	SW-846 8270 SIM	Acenaphthene	260 D	µg/kg	HT	16	days	J	Low	Datum is estimated; potentially biased low Preparation holding time exceeded
RS	RS-210306-0930-RR2-DUP	03/21/06	SW-846 8270 SIM	Acenaphthylene	440 D	µg/kg	HT	16	days	J	Low	Datum is estimated; potentially biased low Preparation holding time exceeded
RS	RS-210306-0930-RR2-DUP	03/21/06	SW-846 8270 SIM	Anthracene	720 D	µg/kg	HT	16	days	J	Low	Datum is estimated; potentially biased low Preparation holding time exceeded
RS	RS-210306-0930-RR2-DUP	03/21/06	SW-846 8270 SIM	Benzo(a)anthracene	1400 D	µg/kg	HT	16	days	J	Low	Datum is estimated; potentially biased low Preparation holding time exceeded
RS	RS-210306-0930-RR2-DUP	03/21/06	SW-846 8270 SIM	Benzo(a)pyrene	1400 D	µg/kg	HT	16	days	J	Low	Datum is estimated; potentially biased low Preparation holding time exceeded
RS	RS-210306-0930-RR2-DUP	03/21/06	SW-846 8270 SIM	Benzo(b)fluoranthene	1500 D	µg/kg	HT	16	days	J	Low	Datum is estimated; potentially biased low Preparation holding time exceeded
RS	RS-210306-0930-RR2-DUP	03/21/06	SW-846 8270 SIM	Benzo(g,h,i)perylene	910 D	µg/kg	HT	16	days	J	Low	Datum is estimated; potentially biased low Preparation holding time exceeded

TABLE 1
DATA QUALIFIERS SUMMARY TABLE
DEMONSTRATION TESTING AND FULL-SCALE OPERATION OF THE BIOGENESIS SEDIMENT DECONTAMINATION PROCESS, KEASBEY, NEW JERSEY
(Page120 of 188)

Location Identification	Sample Identification	Sample Date	Analysis	Analyte	Sample Result	Sample Units	QC Type	QC Result	QC Units	Qualifier	Bias	Comment
RS	RS-210306-0930-RR2-DUP	03/21/06	SW-846 8270 SIM	Benzo(k)fluoranthene	670 D	µg/kg	HT	16	days	J	Low	Datum is estimated; potentially biased low Preparation holding time exceeded
RS	RS-210306-0930-RR2-DUP	03/21/06	SW-846 8270 SIM	Chrysene	1600 D	µg/kg	HT	16	days	J	Low	Datum is estimated; potentially biased low Preparation holding time exceeded
RS	RS-210306-0930-RR2-DUP	03/21/06	SW-846 8270 SIM	Dibenz(a,h)anthracene	260 D	µg/kg	HT	16	days	J	Low	Datum is estimated; potentially biased low Preparation holding time exceeded
RS	RS-210306-0930-RR2-DUP	03/21/06	SW-846 8270 SIM	Fluoranthene	2100 D	µg/kg	HT	16	days	J	Low	Datum is estimated; potentially biased low Preparation holding time exceeded
RS	RS-210306-0930-RR2-DUP	03/21/06	SW-846 8270 SIM	Fluorene	250 D	µg/kg	HT	16	days	J	Low	Datum is estimated; potentially biased low Preparation holding time exceeded
RS	RS-210306-0930-RR2-DUP	03/21/06	SW-846 8270 SIM	Indeno(1,2,3-c,d)pyrene	800 D	µg/kg	HT	16	days	J	Low	Datum is estimated; potentially biased low Preparation holding time exceeded
RS	RS-210306-0930-RR2-DUP	03/21/06	SW-846 8270 SIM	Naphthalene	340 D	µg/kg	HT	16	days	J	Low	Datum is estimated; potentially biased low Preparation holding time exceeded
RS	RS-210306-0930-RR2-DUP	03/21/06	SW-846 8270 SIM	Phenanthrene	1200 D	µg/kg	HT	16	days	J	Low	Datum is estimated; potentially biased low Preparation holding time exceeded
RS	RS-210306-0930-RR2-DUP	03/21/06	SW-846 8270 SIM	Pyrene	2800 D	µg/kg	HT	16	days	J	Low	Datum is estimated; potentially biased low Preparation holding time exceeded
RS	RS-210306-0930-RR2-SE	03/21/06	SW-846 8270 SIM	Acenaphthene	28	µg/kg	HT	16	days	J	Low	Datum is estimated; potentially biased low Preparation holding time exceeded
RS	RS-210306-0930-RR2-SE	03/21/06	SW-846 8270 SIM	Acenaphthylene	38	µg/kg	HT	16	days	J	Low	Datum is estimated; potentially biased low Preparation holding time exceeded
RS	RS-210306-0930-RR2-SE	03/21/06	SW-846 8270 SIM	Anthracene	110	µg/kg	HT	16	days	J	Low	Datum is estimated; potentially biased low Preparation holding time exceeded
RS	RS-210306-0930-RR2-SE	03/21/06	SW-846 8270 SIM	Benzo(a)anthracene	150	µg/kg	HT	16	days	J	Low	Datum is estimated; potentially biased low Preparation holding time exceeded
RS	RS-210306-0930-RR2-SE	03/21/06	SW-846 8270 SIM	Benzo(a)pyrene	140	µg/kg	HT	16	days	J	Low	Datum is estimated; potentially biased low Preparation holding time exceeded
RS	RS-210306-0930-RR2-SE	03/21/06	SW-846 8270 SIM	Benzo(b)fluoranthene	170	µg/kg	HT	16	days	J	Low	Datum is estimated; potentially biased low Preparation holding time exceeded
RS	RS-210306-0930-RR2-SE	03/21/06	SW-846 8270 SIM	Benzo(g,h,i)perylene	100	µg/kg	HT	16	days	J	Low	Datum is estimated; potentially biased low Preparation holding time exceeded
RS	RS-210306-0930-RR2-SE	03/21/06	SW-846 8270 SIM	Benzo(k)fluoranthene	62	µg/kg	HT	16	days	J	None	Datum is estimated, possible low bias; preparation holding time exceeded

TABLE 1
DATA QUALIFIERS SUMMARY TABLE
DEMONSTRATION TESTING AND FULL-SCALE OPERATION OF THE BIOGENESIS SEDIMENT DECONTAMINATION PROCESS, KEASBEY, NEW JERSEY
(Page121 of 188)

Location Identification	Sample Identification	Sample Date	Analysis	Analyte	Sample Result	Sample Units	QC Type	QC Result	QC Units	Qualifier	Bias	Comment
RS	RS-210306-0930-RR2-SE	03/21/06	SW-846 8270 SIM	Chrysene	170	µg/kg	HT	16	days	J	Low	Datum is estimated; potentially biased low Preparation holding time exceeded
RS	RS-210306-0930-RR2-SE	03/21/06	SW-846 8270 SIM	Dibenz(a,h)anthracene	26 T	µg/kg	HT	16	days	J	Low	Datum is estimated; potentially biased low Preparation holding time exceeded
RS	RS-210306-0930-RR2-SE	03/21/06	SW-846 8270 SIM	Fluoranthene	260	µg/kg	HT	16	days	J	Low	Datum is estimated; potentially biased low Preparation holding time exceeded
RS	RS-210306-0930-RR2-SE	03/21/06	SW-846 8270 SIM	Fluorene	31	µg/kg	HT	16	days	J	Low	Datum is estimated; potentially biased low Preparation holding time exceeded
RS	RS-210306-0930-RR2-SE	03/21/06	SW-846 8270 SIM	Indeno(1,2,3-c,d)pyrene	89	µg/kg	HT	16	days	J	Low	Datum is estimated; potentially biased low Preparation holding time exceeded
RS	RS-210306-0930-RR2-SE	03/21/06	SW-846 8270 SIM	Naphthalene	84	µg/kg	HT	16	days	J	Low	Datum is estimated; potentially biased low Preparation holding time exceeded
RS	RS-210306-0930-RR2-SE	03/21/06	SW-846 8270 SIM	Phenanthrene	140	µg/kg	HT	16	days	J	Low	Datum is estimated; potentially biased low Preparation holding time exceeded
RS	RS-210306-0930-RR2-SE	03/21/06	SW-846 8270 SIM	Pyrene	370	µg/kg	HT	16	days	J	Low	Datum is estimated; potentially biased low Preparation holding time exceeded
RS	RS-210306-0930-RR2-SE-DUP	03/21/06	SW-846 8270 SIM	Acenaphthene	28	µg/kg	HT	16	days	J	Low	Datum is estimated; potentially biased low Preparation holding time exceeded
RS	RS-210306-0930-RR2-SE-DUP	03/21/06	SW-846 8270 SIM	Acenaphthylene	42	µg/kg	HT	16	days	J	Low	Datum is estimated; potentially biased low Preparation holding time exceeded
RS	RS-210306-0930-RR2-SE-DUP	03/21/06	SW-846 8270 SIM	Anthracene	110	µg/kg	HT	16	days	J	Low	Datum is estimated; potentially biased low Preparation holding time exceeded
RS	RS-210306-0930-RR2-SE-DUP	03/21/06	SW-846 8270 SIM	Benzo(a)anthracene	140	µg/kg	HT	16	days	J	Low	Datum is estimated; potentially biased low Preparation holding time exceeded
RS	RS-210306-0930-RR2-SE-DUP	03/21/06	SW-846 8270 SIM	Benzo(a)pyrene	130	µg/kg	HT	16	days	J	Low	Datum is estimated; potentially biased low Preparation holding time exceeded
RS	RS-210306-0930-RR2-SE-DUP	03/21/06	SW-846 8270 SIM	Benzo(b)fluoranthene	150	µg/kg	HT	16	days	J	Low	Datum is estimated; potentially biased low Preparation holding time exceeded
RS	RS-210306-0930-RR2-SE-DUP	03/21/06	SW-846 8270 SIM	Benzo(g,h,i)perylene	100	µg/kg	HT	16	days	J	Low	Datum is estimated; potentially biased low Preparation holding time exceeded
RS	RS-210306-0930-RR2-SE-DUP	03/21/06	SW-846 8270 SIM	Benzo(k)fluoranthene	68	µg/kg	HT	16	days	J	None	Datum is estimated, possible low bias; preparation holding time exceeded
RS	RS-210306-0930-RR2-SE-DUP	03/21/06	SW-846 8270 SIM	Chrysene	160	µg/kg	HT	16	days	J	Low	Datum is estimated; potentially biased low Preparation holding time exceeded

TABLE 1
DATA QUALIFIERS SUMMARY TABLE
DEMONSTRATION TESTING AND FULL-SCALE OPERATION OF THE BIOGENESIS SEDIMENT DECONTAMINATION PROCESS, KEASBEY, NEW JERSEY
(Page 122 of 188)

Location Identification	Sample Identification	Sample Date	Analysis	Analyte	Sample Result	Sample Units	QC Type	QC Result	QC Units	Qualifier	Bias	Comment
RS	RS-210306-0930-RR2-SE-DUP	03/21/06	SW-846 8270 SIM	Dibenz(a,h)anthracene	29	µg/kg	HT	16	days	J	Low	Datum is estimated; potentially biased low Preparation holding time exceeded
RS	RS-210306-0930-RR2-SE-DUP	03/21/06	SW-846 8270 SIM	Fluoranthene	250	µg/kg	HT	16	days	J	Low	Datum is estimated; potentially biased low Preparation holding time exceeded
RS	RS-210306-0930-RR2-SE-DUP	03/21/06	SW-846 8270 SIM	Fluorene	33	µg/kg	HT	16	days	J	Low	Datum is estimated; potentially biased low Preparation holding time exceeded
RS	RS-210306-0930-RR2-SE-DUP	03/21/06	SW-846 8270 SIM	Indeno(1,2,3-c,d)pyrene	93	µg/kg	HT	16	days	J	Low	Datum is estimated; potentially biased low Preparation holding time exceeded
RS	RS-210306-0930-RR2-SE-DUP	03/21/06	SW-846 8270 SIM	Naphthalene	93	µg/kg	HT	16	days	J	Low	Datum is estimated; potentially biased low Preparation holding time exceeded
RS	RS-210306-0930-RR2-SE-DUP	03/21/06	SW-846 8270 SIM	Phenanthrene	130	µg/kg	HT	16	days	J	Low	Datum is estimated; potentially biased low Preparation holding time exceeded
RS	RS-210306-0930-RR2-SE-DUP	03/21/06	SW-846 8270 SIM	Pyrene	350	µg/kg	HT	16	days	J	Low	Datum is estimated; potentially biased low Preparation holding time exceeded
SS1	SS1-210306-0920-RR	03/21/06	SW-846 8270 SIM	Anthracene	4100 D	µg/kg	MS MSD	16 16	%	J	Low	Datum is estimated, possible low bias; MS/MSD recoveries outside acceptance criteria
SS1	SS1-210306-0920-RR	03/21/06	SW-846 8270 SIM	Benzo(g,h,i)perylene	3400 D	µg/kg	MS MSD	140 139	%	J	High	Datum is estimated, possible high bias; MS/MSD recoveries outside acceptance criteria
SS1	SS1-210306-0920-RR	03/21/06	SW-846 8270 SIM	Benzo(k)fluoranthene	2300 D	µg/kg	MS	139	%	J	High	Datum is estimated, possible high bias; MS recovery outside acceptance criteria
SS1	SS1-210306-0920-RR	03/21/06	SW-846 8270 SIM	Benzo(k)fluoranthene	1800 D	µg/kg	MS	139	%	J	High	Datum is estimated, possible high bias; MS recovery outside acceptance criteria
SS1	SS1-210306-0920-RR	03/21/06	SW-846 8270 SIM	Fluorene	2000 D	µg/kg	MS MSD	0 0	%	J	Low	Datum is estimated, possible low bias; MS/MSD recoveries outside acceptance criteria
SS1	SS1-210306-0920-RR	03/21/06	SW-846 8270 SIM	Acenaphthene	1800 D	µg/kg	MS MSD	7.6 0	%	J	Low	Datum is estimated, possible low bias; MS/MSD recoveries outside acceptance criteria
SS1	SS1-210306-0920-RR	03/21/06	SW-846 8270 SIM	Benzo(a)pyrene	4700 D	µg/kg	MS MSD	144 145	%	J	High	Datum is estimated, possible high bias; MS/MSD recoveries outside acceptance criteria
SS1	SS1-210306-0920-RR	03/21/06	SW-846 8270 SIM	Chrysene	6200 D	µg/kg	MS MSD	117 120	%	J	High	Datum is estimated, possible high bias; MS/MSD recoveries outside acceptance criteria
SS1	SS1-210306-0920-RR	03/21/06	SW-846 8270 SIM	Indeno(1,2,3-c,d)pyrene	2900 D	µg/kg	MS MSD	121 125	%	J	High	Datum is estimated, possible high bias; MS/MSD recoveries outside acceptance criteria
SS1	SS1-210306-0920-RR	03/21/06	SW-846 8270 SIM	Naphthalene	3400 D	µg/kg	MS MSD	0 0	%	J	Low	Datum is estimated, possible low bias; MS/MSD recoveries outside acceptance criteria
SS1	SS1-210306-0920-RR	03/21/06	SW-846 8270 SIM	Phenanthrene	10000 D	µg/kg	MS MSD	0 0	%	J	Low	Datum is estimated, possible low bias; MS/MSD recoveries outside acceptance criteria
TS	TS-220306-1000	03/22/06	SW-846 6010B	Arsenic	16.8	mg/kg	SLD	11.8	%	J	None	Datum is estimated, bias unknown; serial dilution %D outside acceptance criterion
TS	TS-220306-1000	03/22/06	SW-846 6010B	Barium	269	mg/kg	MS SLD LB	71 10.9 0.25	% %	JB	Low	Datum is estimated, possible low bias; MS recovery and serial dilution percent difference outside acceptance criteria Analyte detected in associated blank; sample concentration greater than five times the blank concentration

TABLE 1
DATA QUALIFIERS SUMMARY TABLE
DEMONSTRATION TESTING AND FULL-SCALE OPERATION OF THE BIOGENESIS SEDIMENT DECONTAMINATION PROCESS, KEASBEY, NEW JERSEY
(Page123 of 188)

Location Identification	Sample Identification	Sample Date	Analysis	Analyte	Sample Result	Sample Units	QC Type	QC Result	QC Units	Qualifier	Bias	Comment
TS	TS-220306-1000	03/22/06	SW-846 6010B	Chromium, total	69.2	mg/kg	MS MSD SLD	25 49 12.1	%	J	Low	Datum is estimated, possible low bias; MS/MSD recoveries and serial dilution %D outside acceptance criteria
TS	TS-220306-1000	03/22/06	SW-846 6010B	Lead	175	mg/kg	SLD	14.1	%	J	None	Datum is estimated, bias unknown; serial dilution %D outside acceptance criterion
TS	TS-220306-1000	03/22/06	SW-846 6010B	Nickel	34.4	mg/kg	SLD	12.4	%	J	None	Datum is estimated, bias unknown; serial dilution %D outside acceptance criterion
TS	TS-220306-1000	03/22/06	SW-846 6010B	Selenium	1.2	mg/kg	SLD	59.5	%	J	None	Datum is estimated, bias unknown; serial dilution %D outside acceptance criterion
TS	TS-220306-1000	03/22/06	SW-846 6010B	Zinc	213	mg/kg	SLD LB	16.7 0.97	% mg/kg	JB	None	Datum is estimated, bias unknown; serial dilution percent difference outside acceptance criterion. Analyte detected in associated blank; sample concentration greater than five times the blank concentration.
TS1	TS1-220306-1005	03/22/06	SW-846 6010B	Barium	55	mg/kg	LB	0.25	mg/kg	B	None	Analyte detected in associated blank; sample concentration greater than five times the blank concentration.
TS1	TS1-220306-1005	03/22/06	SW-846 6010B	Zinc	165	mg/kg	LB	0.97	mg/kg	B	None	Analyte detected in associated blank; sample concentration greater than five times the blank concentration.
TS2	TS2-220306-1010	03/22/06	SW-846 6010B	Barium	231	mg/kg	LB	0.25	mg/kg	B	None	Analyte detected in associated blank; sample concentration greater than five times the blank concentration.
TS2	TS2-220306-1010	03/22/06	SW-846 6010B	Zinc	168	mg/kg	LB	0.97	mg/kg	B	None	Analyte detected in associated blank; sample concentration greater than five times the blank concentration.
TS3	TS3-220306-1015	03/22/06	SW-846 6010B	Barium	361	mg/kg	LB	0.25	mg/kg	B	None	Analyte detected in associated blank; sample concentration greater than five times the blank concentration.
TS3	TS3-220306-1015	03/22/06	SW-846 6010B	Zinc	275	mg/kg	LB	0.97	mg/kg	B	None	Analyte detected in associated blank; sample concentration greater than five times the blank concentration.
TS	TS-230306-0930	03/23/06	SW-846 6010B	Chromium, total	59	mg/kg	MSD	136	%	J	High	Datum is estimated, possible high bias; MSD recovery outside acceptance criteria
TS	TS-230306-0930	03/23/06	SW-846 6010B	Selenium	1.2	mg/kg	SLD	12.1	%	J	None	Datum is estimated, bias unknown; serial dilution %D outside acceptance criterion
TS	TS-230306-0930	03/23/06	SW-846 6010B	Zinc	209	mg/kg	SLD	13.4	%	J	None	Datum is estimated, bias unknown; serial dilution %D outside acceptance criterion
PSS	PSS-270306-1100	03/27/06	SW-846 6010B	Chromium, total	152	mg/kg	MS MSD	180 203	%	J	High	Datum is estimated, possible high bias; MS/MSD recoveries outside acceptance criteria

TABLE 1
DATA QUALIFIERS SUMMARY TABLE
DEMONSTRATION TESTING AND FULL-SCALE OPERATION OF THE BIOGENESIS SEDIMENT DECONTAMINATION PROCESS, KEASBEY, NEW JERSEY
(Page 124 of 188)

Location Identification	Sample Identification	Sample Date	Analysis	Analyte	Sample Result	Sample Units	QC Type	QC Result	QC Units	Qualifier	Bias	Comment
PSS	PSS-270306-1100	03/27/06	SW-846 6010B	Lead	315	mg/kg	MS	152	%	J	High	Datum is estimated, possible high bias; MS/MSD recoveries outside acceptance criteria
PSS	PSS-270306-1100	03/27/06	SW-846 6010B	Selenium	1.2	mg/kg	MSD SLD	163 100	%	J	None	Datum is estimated, bias unknown; serial dilution %D outside acceptance criterion
PSS	PSS-270306-1100	03/27/06	SW-846 6010B	Silver	4.9	mg/kg	SLD LB	17.5 0.052 T	% mg/kg	JB	None	Datum is estimated, bias unknown; serial dilution percent difference outside acceptance criterion. Analyte detected in associated blank; sample concentration greater than five times the blank concentration.
TS	TS-270306-1320	03/27/06	SW-846 6010B	Silver	3.2	mg/kg	LB	0.052 T	mg/kg	B	None	Analyte detected in associated blank; sample concentration greater than five times the blank concentration.
CENTRATE 1	CENTRATE 1	03/30/06	SW-846 6010B	Zinc	1280	mg/kg	LB	0.18 T	mg/kg	B	None	Analyte detected in associated blank; sample concentration greater than five times the blank concentration.
PSS	PSS-300306-1300	03/30/06	SW-846 8270 SIM	Benzo(g,h,i)perylene	940 D	µg/kg	CVS	34.2	%	J	None	Datum is estimated, bias unknown; CVS %D outside acceptance criterion.
PSS	PSS-300306-1300	03/30/06	SW-846 8270 SIM	Dibenz(a,h)anthracene	270 D	µg/kg	CVS	33.1	%	J	None	Datum is estimated, bias unknown; CVS %D outside acceptance criterion.
PSS	PSS-300306-1300	03/30/06	SW-846 6010B	Arsenic	24	mg/kg	SLD	14.3	%	J	None	Datum is estimated, bias unknown; serial dilution %D outside acceptance criterion.
PSS	PSS-300306-1300	03/30/06	SW-846 6010B	Cadmium	5	mg/kg	SLD	10.8	%	J	None	Datum is estimated, bias unknown; serial dilution %D outside acceptance criterion.
PSS	PSS-300306-1300	03/30/06	SW-846 6010B	Chromium, total	163	mg/kg	SLD	10.2	%	J	None	Datum is estimated, bias unknown; serial dilution %D outside acceptance criterion.
PSS	PSS-300306-1300	03/30/06	SW-846 6010B	Lead	249	mg/kg	MSD SLD	150 12.3	%	J	High	Datum is estimated, possible high bias; MSD recovery and serial dilution %D outside acceptance criteria.
PSS	PSS-300306-1300	03/30/06	SW-846 6010B	Nickel	44.9	mg/kg	SLD	11.7	%	J	None	Datum is estimated, bias unknown; serial dilution %D outside acceptance criterion.
PSS	PSS-300306-1300	03/30/06	SW-846 6010B	Selenium	1.6	mg/kg	SLD	100	%	J	None	Datum is estimated, bias unknown; serial dilution %D outside acceptance criterion.
PSS	PSS-300306-1300	03/30/06	SW-846 6010B	Silver	4.4	mg/kg	SLD	12.8	%	J	None	Datum is estimated, bias unknown; serial dilution %D outside acceptance criterion.
PSS	PSS-300306-1300	03/30/06	SW-846 6010B	Zinc	386	mg/kg	SLD LB	14.5 0.18 T	% mg/kg	JB	None	Datum is estimated, bias unknown; serial dilution percent difference outside acceptance criterion. Analyte detected in associated blank; sample concentration greater than five times the blank concentration.
PSS	PSS-300306-1300-AD	03/30/06	SW-846 8270 SIM	Phenanthrene	1100 D	µg/kg	MS MSD	0 0	%	J	Low	Datum is estimated, possible low bias; MS/MSD recoveries outside acceptance criteria.
PSS	PSS-300306-1300-AD	03/30/06	SW-846 8270 SIM	Pyrene	2400 D	µg/kg	MS MSD	0 0	%	J	Low	Datum is estimated, possible low bias; MS/MSD recoveries outside acceptance criteria.

TABLE 1
DATA QUALIFIERS SUMMARY TABLE
DEMONSTRATION TESTING AND FULL-SCALE OPERATION OF THE BIOGENESIS SEDIMENT DECONTAMINATION PROCESS, KEASBEY, NEW JERSEY
(Page 125 of 188)

Location Identification	Sample Identification	Sample Date	Analysis	Analyte	Sample Result	Sample Units	QC Type	QC Result	QC Units	Qualifier	Bias	Comment
PSS	PSS-300306-1300-AD	03/30/06	SW-846 8270 SIM	Naphthalene	330 D	µg/kg	MS MSD	0 0	%	J	Low	Datum is estimated, possible low bias; MS/MSD recoveries outside acceptance criteria
RS	RS-300306-1315	03/30/06	SW-846 8270 SIM	Benzo(g,h,i)perylene	940 D	µg/kg	CVS	34.2	%	J	None	Datum is estimated, bias unknown; CVS %D outside acceptance criterion
RS	RS-300306-1315	03/30/06	SW-846 8270 SIM	Dibenz(a,h)anthracene	270 D	µg/kg	CVS	33.1	%	J	None	Datum is estimated, bias unknown; CVS %D outside acceptance criterion
RS	RS-300306-1315	03/30/06	SW-846 6010B	Zinc	469	mg/kg	LB	0.18 T	mg/kg	B	None	Analyte detected in associated blank; sample concentration greater than five times the blank concentration
RS	RS-300306-1315-DUP-SE	03/30/06	SW-846 8270 SIM	Fluorene	48 TD	µg/kg	CVS	26.3	%	J	None	Datum is estimated, bias unknown; CVS %D outside acceptance criterion
SS1	SS1-300306-1305	03/30/06	SW-846 8270 SIM	Benzo(g,h,i)perylene	1500 D	µg/kg	CVS	34.2	%	J	None	Datum is estimated, bias unknown; CVS %D outside acceptance criterion
SS1	SS1-300306-1305	03/30/06	SW-846 8270 SIM	Dibenz(a,h)anthracene	480 D	µg/kg	CVS	33.1	%	J	None	Datum is estimated, bias unknown; CVS %D outside acceptance criterion
SS1	SS1-300306-1305	03/30/06	SW-846 6010B	Zinc	170	mg/kg	LB	0.18 T	mg/kg	B	None	Analyte detected in associated blank; sample concentration greater than five times the blank concentration
SS1	SS1-300306-1305-AD	03/30/06	SW-846 8270 SIM	Benzo(a)pyrene	7700 D	µg/kg	IS	>200		J	None	Datum is estimated, bias unknown; IS area recovery outside acceptance criteria
SS1	SS1-300306-1305-AD	03/30/06	SW-846 8270 SIM	Benzo(b)fluoranthene	8900 D	µg/kg	IS	>200		J	None	Datum is estimated, bias unknown; IS area recovery outside acceptance criteria
SS1	SS1-300306-1305-AD	03/30/06	SW-846 8270 SIM	Benzo(g,h,i)perylene	3500 D	µg/kg	IS	>200		J	None	Datum is estimated, bias unknown; IS area recovery outside acceptance criteria
SS1	SS1-300306-1305-AD	03/30/06	SW-846 8270 SIM	Benzo(k)fluoranthene	3600 D	µg/kg	IS	>200		J	None	Datum is estimated, bias unknown; IS area recovery outside acceptance criteria
SS1	SS1-300306-1305-AD	03/30/06	SW-846 8270 SIM	Dibenz(a,h)anthracene	1300 D	µg/kg	IS	>200		J	None	Datum is estimated, bias unknown; IS area recovery outside acceptance criteria
SS1	SS1-300306-1305-AD	03/30/06	SW-846 8270 SIM	Indeno(1,2,3-c,d)pyrene	3700 D	µg/kg	IS	>200		J	None	Datum is estimated, bias unknown; IS area recovery outside acceptance criteria
SS1	SS1-300306-1305-DUP-SE	03/30/06	SW-846 8270 SIM	Fluorene	80 D	µg/kg	CVS	26.3	%	J	None	Datum is estimated, bias unknown; CVS %D outside acceptance criterion
SS2	SS2-300306-1310	03/30/06	SW-846 8270 SIM	Benzo(g,h,i)perylene	1200 D	µg/kg	CVS	34.2	%	J	None	Datum is estimated, bias unknown; CVS %D outside acceptance criterion
SS2	SS2-300306-1310	03/30/06	SW-846 8270 SIM	Dibenz(a,h)anthracene	440 D	µg/kg	CVS	33.1	%	J	None	Datum is estimated, bias unknown; CVS %D outside acceptance criterion

TABLE 1
DATA QUALIFIERS SUMMARY TABLE
DEMONSTRATION TESTING AND FULL-SCALE OPERATION OF THE BIOGENESIS SEDIMENT DECONTAMINATION PROCESS, KEASBEY, NEW JERSEY
(Page 126 of 188)

Location Identification	Sample Identification	Sample Date	Analysis	Analyte	Sample Result	Sample Units	QC Type	QC Result	QC Units	Qualifier	Bias	Comment	
SS2	SS2-300306-1310	03/30/06	SW-846 6010B	Zinc	240	mg/kg	LB	0.18	T	mg/kg	B	None	Analyte detected in associated blank; sample concentration greater than five times the blank concentration
SS2	SS2-300306-1310-DUP-SE	03/30/06	SW-846 8270 SIM	Fluorene	68	D	µg/kg	CVS	26.3	%	J	None	Datum is estimated, bias unknown; CVS %D outside acceptance criterion
TS	TS-300306-1320	03/30/06	SW-846 8270 SIM	Benzo(g,h,i)perylene	1500	D	µg/kg	CVS	34.2	%	J	None	Datum is estimated, bias unknown; CVS %D outside acceptance criterion
TS	TS-300306-1320	03/30/06	SW-846 8270 SIM	Dibenz(a,h)anthracene	420	D	µg/kg	CVS	33.1	%	J	None	Datum is estimated, bias unknown; CVS %D outside acceptance criterion
TS	TS-300306-1320	03/30/06	SW-846 6010B	Zinc	355	mg/kg	LB	0.18	T	mg/kg	B	None	Analyte detected in associated blank; sample concentration greater than five times the blank concentration
TS1	TS1-300306-1325	03/30/06	SW-846 6010B	Zinc	218	mg/kg	LB	0.18	T	mg/kg	B	None	Analyte detected in associated blank; sample concentration greater than five times the blank concentration
TS2	TS2-300306-1330	03/30/06	SW-846 8270 SIM	Benzo(g,h,i)perylene	1100	D	µg/kg	CVS	34.2	%	J	None	Datum is estimated, bias unknown; CVS %D outside acceptance criterion
TS2	TS2-300306-1330	03/30/06	SW-846 8270 SIM	Dibenz(a,h)anthracene	310	D	µg/kg	CVS	33.1	%	J	None	Datum is estimated, bias unknown; CVS %D outside acceptance criterion
TS2	TS2-300306-1330	03/30/06	SW-846 6010B	Zinc	188	mg/kg	LB	0.18	T	mg/kg	B	None	Analyte detected in associated blank; sample concentration greater than five times the blank concentration
TS3	TS3-300306-1335	03/30/06	SW-846 8270 SIM	Benzo(g,h,i)perylene	1200	D	µg/kg	CVS	34.2	%	J	None	Datum is estimated, bias unknown; CVS %D outside acceptance criterion
TS3	TS3-300306-1335	03/30/06	SW-846 8270 SIM	Dibenz(a,h)anthracene	330	D	µg/kg	CVS	33.1	%	J	None	Datum is estimated, bias unknown; CVS %D outside acceptance criterion
TS3	TS3-300306-1335	03/30/06	SW-846 6010B	Zinc	364	mg/kg	LB	0.18	T	mg/kg	B	None	Analyte detected in associated blank; sample concentration greater than five times the blank concentration
WS	WS-300306-1345	03/30/06	SW-846 8270 SIM	Benzo(g,h,i)perylene	1100	D	µg/kg	CVS	34.2	%	J	None	Datum is estimated, bias unknown; CVS %D outside acceptance criterion
WS	WS-300306-1345	03/30/06	SW-846 8270 SIM	Dibenz(a,h)anthracene	270	TD	µg/kg	CVS	33.1	%	J	None	Datum is estimated, bias unknown; CVS %D outside acceptance criterion
WS	WS-300306-1345	03/30/06	SW-846 6010B	Zinc	1360	mg/kg	LB	0.18	T	mg/kg	B	None	Analyte detected in associated blank; sample concentration greater than five times the blank concentration

TABLE 1
DATA QUALIFIERS SUMMARY TABLE
DEMONSTRATION TESTING AND FULL-SCALE OPERATION OF THE BIOGENESIS SEDIMENT DECONTAMINATION PROCESS, KEASBEY, NEW JERSEY
(Page 127 of 188)

Location Identification	Sample Identification	Sample Date	Analysis	Analyte	Sample Result	Sample Units	QC Type	QC Result	QC Units	Qualifier	Bias	Comment
RS	FD-431520	04/03/06	SW-846 8270 SIM	Pyrene	2100 D	µg/kg	CVS	29	%	J	None	Datum is estimated, bias unknown; CVS %D outside acceptance criterion
RS	FD-431520	04/03/06	SW-846 6010B	Zinc	355	mg/kg	LB	0.76 T	mg/kg	B	None	Analyte detected in associated blank; sample concentration greater than five times the blank concentration
RS	INF-431525	04/03/06	SW-846 8270 SIM	Pyrene	1900 D	µg/kg	CVS	29	%	J	None	Datum is estimated, bias unknown; CVS %D outside acceptance criterion
RS	INF-431525	04/03/06	SW-846 6010B	Zinc	368	mg/kg	LB	0.76 T	mg/kg	B	None	Analyte detected in associated blank; sample concentration greater than five times the blank concentration
PSS	PSS-030406-1500	04/03/06	SW-846 8270 SIM	Pyrene	2000 D	µg/kg	CVS	29	%	J	None	Datum is estimated, bias unknown; CVS %D outside acceptance criterion
PSS	PSS-030406-1500	04/03/06	SW-846 6010B	Arsenic	23.8	mg/kg	SLD	12.6	%	J	None	Datum is estimated, bias unknown; serial dilution %D outside acceptance criterion
PSS	PSS-030406-1500	04/03/06	SW-846 6010B	Selenium	1.4	mg/kg	SLD	100	%	J	None	Datum is estimated, bias unknown; serial dilution %D outside acceptance criterion
PSS	PSS-030406-1500	04/03/06	SW-846 6010B	Zinc	374	mg/kg	LB	0.76 T	mg/kg	B	None	Analyte detected in associated blank; sample concentration greater than five times the blank concentration
RS	RS-030406-1515	04/03/06	SW-846 8270 SIM	Pyrene	2700 D	µg/kg	CVS	29	%	J	None	Datum is estimated, bias unknown; CVS %D outside acceptance criterion
RS	RS-030406-1515	04/03/06	SW-846 6010B	Zinc	333	mg/kg	LB	0.76 T	mg/kg	B	None	Analyte detected in associated blank; sample concentration greater than five times the blank concentration
SS1	SS1-030406-1505	04/03/06	SW-846 8270 SIM	Pyrene	9400 D	µg/kg	CVS	29	%	J	None	Datum is estimated, bias unknown; CVS %D outside acceptance criterion
SS1	SS1-030406-1505	04/03/06	SW-846 6010B	Zinc	291	mg/kg	LB	0.76 T	mg/kg	B	None	Analyte detected in associated blank; sample concentration greater than five times the blank concentration
SS2	SS2-030406-1510	04/03/06	SW-846 8270 SIM	Pyrene	11000 D	µg/kg	CVS	29	%	J	None	Datum is estimated, bias unknown; CVS %D outside acceptance criterion
SS2	SS2-030406-1510	04/03/06	SW-846 6010B	Zinc	281	mg/kg	LB	0.76 T	mg/kg	B	None	Analyte detected in associated blank; sample concentration greater than five times the blank concentration
TS	TS-030406-1540	04/03/06	SW-846 8270 SIM	Pyrene	2500 D	µg/kg	CVS	29	%	J	None	Datum is estimated, bias unknown; CVS %D outside acceptance criterion

TABLE 1
DATA QUALIFIERS SUMMARY TABLE
DEMONSTRATION TESTING AND FULL-SCALE OPERATION OF THE BIOGENESIS SEDIMENT DECONTAMINATION PROCESS, KEASBEY, NEW JERSEY
(Page 128 of 188)

Location Identification	Sample Identification	Sample Date	Analysis	Analyte	Sample Result	Sample Units	QC Type	QC Result	QC Units	Qualifier	Bias	Comment
TS	TS-030406-1540	04/03/06	SW-846 6010B	Zinc	260	mg/kg	LB	0.76 T	mg/kg	B	None	Analyte detected in associated blank; sample concentration greater than five times the blank concentration
TS1	TS1-030406-1525	04/03/06	SW-846 8270 SIM	Pyrene	5400 D	µg/kg	CVS	29	%	J	None	Datum is estimated, bias unknown; CVS %D outside acceptance criterion
TS1	TS1-030406-1525	04/03/06	SW-846 6010B	Zinc	184	mg/kg	LB	0.76 T	mg/kg	B	None	Analyte detected in associated blank; sample concentration greater than five times the blank concentration
TS2	TS2-030406-1530	04/03/06	SW-846 8270 SIM	Pyrene	9700 D	µg/kg	CVS	29	%	J	None	Datum is estimated, bias unknown; CVS %D outside acceptance criterion
TS2	TS2-030406-1530	04/03/06	SW-846 6010B	Zinc	179	mg/kg	LB	0.76 T	mg/kg	B	None	Analyte detected in associated blank; sample concentration greater than five times the blank concentration
TS3	TS3-030406-1535	04/03/06	SW-846 8270 SIM	Pyrene	1400 D	µg/kg	CVS	29	%	J	None	Datum is estimated, bias unknown; CVS %D outside acceptance criterion
TS3	TS3-030406-1535	04/03/06	SW-846 6010B	Zinc	276	mg/kg	LB	0.76 T	mg/kg	B	None	Analyte detected in associated blank; sample concentration greater than five times the blank concentration
WS	WS-030406-1600	04/03/06	SW-846 8270 SIM	Benzo(a)pyrene	880 D	µg/kg	IS	>200		J	None	Datum is estimated, bias unknown; IS area recovery outside acceptance criteria
WS	WS-030406-1600	04/03/06	SW-846 8270 SIM	Benzo(b)fluoranthene	1200 D	µg/kg	IS	>200		J	None	Datum is estimated, bias unknown; IS area recovery outside acceptance criteria
WS	WS-030406-1600	04/03/06	SW-846 8270 SIM	Benzo(g,h,i)perylene	420 D	µg/kg	IS	>200		J	None	Datum is estimated, bias unknown; IS area recovery outside acceptance criteria
WS	WS-030406-1600	04/03/06	SW-846 8270 SIM	Benzo(k)fluoranthene	380 D	µg/kg	IS	>200		J	None	Datum is estimated, bias unknown; IS area recovery outside acceptance criteria
WS	WS-030406-1600	04/03/06	SW-846 8270 SIM	Dibenz(a,h)anthracene	140 D	µg/kg	IS	>200		J	None	Datum is estimated, bias unknown; IS area recovery outside acceptance criteria
WS	WS-030406-1600	04/03/06	SW-846 8270 SIM	Indeno(1,2,3-c,d)pyrene	400 D	µg/kg	IS	>200		J	None	Datum is estimated, bias unknown; IS area recovery outside acceptance criteria
WS	WS-030406-1600	04/03/06	SW-846 6010B	Zinc	831	mg/kg	LB	0.76 T	mg/kg	B	None	Analyte detected in associated blank; sample concentration greater than five times the blank concentration
PSS	PSS-040406-1200	04/04/06	SW-846 6010B	Zinc	290	mg/kg	LB	0.76 T	mg/kg	B	None	Analyte detected in associated blank; sample concentration greater than five times the blank concentration

TABLE 1
DATA QUALIFIERS SUMMARY TABLE
DEMONSTRATION TESTING AND FULL-SCALE OPERATION OF THE BIOGENESIS SEDIMENT DECONTAMINATION PROCESS, KEASBEY, NEW JERSEY
(Page 129 of 188)

Location Identification	Sample Identification	Sample Date	Analysis	Analyte	Sample Result	Sample Units	QC Type	QC Result	QC Units	Qualifier	Bias	Comment
RS	RS-040406-1215	04/04/06	SW-846 6010B	Zinc	343	mg/kg	LB	0.76 T	mg/kg	B	None	Analyte detected in associated blank; sample concentration greater than five times the blank concentration
SS1	SS1-040406-1205	04/04/06	SW-846 6010B	Zinc	209	mg/kg	LB	0.76 T	mg/kg	B	None	Analyte detected in associated blank; sample concentration greater than five times the blank concentration
SS2	SS2-040406-1210	04/04/06	SW-846 6010B	Zinc	308	mg/kg	LB	0.76 T	mg/kg	B	None	Analyte detected in associated blank; sample concentration greater than five times the blank concentration
TS	TS-040406-1240	04/04/06	SW-846 6010B	Zinc	212	mg/kg	LB	0.76 T	mg/kg	B	None	Analyte detected in associated blank; sample concentration greater than five times the blank concentration
TS1	TS1-040406-1225	04/04/06	SW-846 6010B	Zinc	232	mg/kg	LB	0.76 T	mg/kg	B	None	Analyte detected in associated blank; sample concentration greater than five times the blank concentration
TS2	TS2-040406-1230	04/04/06	SW-846 6010B	Zinc	156	mg/kg	LB	0.76 T	mg/kg	B	None	Analyte detected in associated blank; sample concentration greater than five times the blank concentration
TS3	TS3-040406-1235	04/04/06	SW-846 6010B	Zinc	255	mg/kg	LB	0.76 T	mg/kg	B	None	Analyte detected in associated blank; sample concentration greater than five times the blank concentration
WS	WS-040406-1300	04/04/06	SW-846 6010B	Zinc	693	mg/kg	LB	0.76 T	mg/kg	B	None	Analyte detected in associated blank; sample concentration greater than five times the blank concentration
PSS	PSS-050406-1200	04/05/06	SW-846 8270 SIM	Pyrene	2700 D	µg/kg	CVS	29	%	J	None	Datum is estimated, bias unknown; CVS %D outside acceptance criterion
PSS	PSS-050406-1200	04/05/06	SW-846 6010B	Cadmium	5.9	mg/kg	MSD	46	%	J	Low	Datum is estimated, possible low bias; MSD recovery outside acceptance criteria
PSS	PSS-050406-1200	04/05/06	SW-846 6010B	Lead	257	mg/kg	MSD	131	%	J	High	Datum is estimated, possible high bias; MSD recovery outside acceptance criteria
PSS	PSS-050406-1200	04/05/06	SW-846 6010B	Zinc	419	mg/kg	LB	0.18 T	mg/kg	B	None	Analyte detected in associated blank; sample concentration greater than five times the blank concentration
RS	RS-050406-1215	04/05/06	SW-846 8270 SIM	Pyrene	4700 D	µg/kg	CVS	29	%	J	None	Datum is estimated, bias unknown; CVS %D outside acceptance criterion
RS	RS-050406-1215	04/05/06	SW-846 6010B	Zinc	405	mg/kg	LB	0.18 T	mg/kg	B	None	Analyte detected in associated blank; sample concentration greater than five times the blank concentration

TABLE 1
DATA QUALIFIERS SUMMARY TABLE
DEMONSTRATION TESTING AND FULL-SCALE OPERATION OF THE BIOGENESIS SEDIMENT DECONTAMINATION PROCESS, KEASBEY, NEW JERSEY
(Page130 of 188)

Location Identification	Sample Identification	Sample Date	Analysis	Analyte	Sample Result	Sample Units	QC Type	QC Result	QC Units	Qualifier	Bias	Comment
SS1	SS1-050406-1205	04/05/06	SW-846 8270 SIM	Pyrene	8200 D	µg/kg	CVS	29	%	J	None	Datum is estimated, bias unknown; CVS %D outside acceptance criterion
SS1	SS1-050406-1205	04/05/06	SW-846 6010B	Zinc	177	mg/kg	LB	0.18 T	mg/kg	B	None	Analyte detected in associated blank; sample concentration greater than five times the blank concentration
SS2	SS2-050406-1210	04/05/06	SW-846 8270 SIM	Pyrene	11000 D	µg/kg	CVS	29	%	J	None	Datum is estimated, bias unknown; CVS %D outside acceptance criterion
SS2	SS2-050406-1210	04/05/06	SW-846 6010B	Zinc	503	mg/kg	LB	0.18 T	mg/kg	B	None	Analyte detected in associated blank; sample concentration greater than five times the blank concentration
TS	TS-050406-1240	04/05/06	SW-846 8270 SIM	Pyrene	3600 D	µg/kg	CVS	29	%	J	None	Datum is estimated, bias unknown; CVS %D outside acceptance criterion
TS	TS-050406-1240	04/05/06	SW-846 6010B	Zinc	222	mg/kg	LB	0.18 T	mg/kg	B	None	Analyte detected in associated blank; sample concentration greater than five times the blank concentration
TS1	TS1-050406-1225	04/05/06	SW-846 8270 SIM	Pyrene	4500 D	µg/kg	CVS	29	%	J	None	Datum is estimated, bias unknown; CVS %D outside acceptance criterion
TS1	TS1-050406-1225	04/05/06	SW-846 6010B	Zinc	277	mg/kg	LB	0.18 T	mg/kg	B	None	Analyte detected in associated blank; sample concentration greater than five times the blank concentration
TS2	TS2-050406-1230	04/05/06	SW-846 8270 SIM	Pyrene	10000 D	µg/kg	CVS	29	%	J	None	Datum is estimated, bias unknown; CVS %D outside acceptance criterion
TS2	TS2-050406-1230	04/05/06	SW-846 6010B	Zinc	137	mg/kg	LB	0.18 T	mg/kg	B	None	Analyte detected in associated blank; sample concentration greater than five times the blank concentration
TS3	TS3-050406-1235	04/05/06	SW-846 8270 SIM	Pyrene	1400 D	µg/kg	CVS	29	%	J	None	Datum is estimated, bias unknown; CVS %D outside acceptance criterion
TS3	TS3-050406-1235	04/05/06	SW-846 6010B	Zinc	246	mg/kg	LB	0.18 T	mg/kg	B	None	Analyte detected in associated blank; sample concentration greater than five times the blank concentration
WS	WS-050406-1300	04/05/06	SW-846 8270 SIM	Pyrene	1100 D	µg/kg	CVS	29	%	J	None	Datum is estimated, bias unknown; CVS %D outside acceptance criterion
WS	WS-050406-1300	04/05/06	SW-846 6010B	Zinc	723	mg/kg	LB	0.18 T	mg/kg	B	None	Analyte detected in associated blank; sample concentration greater than five times the blank concentration
PSS	PSS-060406-1200	04/06/06	SW-846 8270 SIM	Dibenz(a,h)anthracene	250 D	µg/kg	LCS	164	%	J	High	Datum is estimated, possible high bias; LCS recovery outside acceptance criteria

TABLE 1
DATA QUALIFIERS SUMMARY TABLE
DEMONSTRATION TESTING AND FULL-SCALE OPERATION OF THE BIOGENESIS SEDIMENT DECONTAMINATION PROCESS, KEASBEY, NEW JERSEY
(Page131 of 188)

Location Identification	Sample Identification	Sample Date	Analysis	Analyte	Sample Result	Sample Units	QC Type	QC Result	QC Units	Qualifier	Bias	Comment
PSS	PSS-060406-1200	04/06/06	SW-846 8270 SIM	Indeno(1,2,3-c,d)pyrene	720 D	µg/kg	LCS	138	%	J	High	Datum is estimated, possible high bias; LCS recovery outside acceptance criteria
PSS	PSS-060406-1200	04/06/06	SW-846 6010B	Lead	290	mg/kg	MSD	225	%	J	High	Datum is estimated, possible high bias; MSD recovery outside acceptance criteria
PSS	PSS-060406-1200	04/06/06	SW-846 6010B	Selenium	2.3	mg/kg	SLD	29.3	%	J	None	Datum is estimated, bias unknown; serial dilution %D outside acceptance criterion
PSS	PSS-060406-1200	04/06/06	SW-846 6010B	Zinc	463	mg/kg	SLD	11.3	%	J	None	Datum is estimated, bias unknown; serial dilution %D outside acceptance criterion
PSS	PSS-060406-1200	04/06/06	SW-846 8270C	2-Methylphenol (o-Cresol)	3100 TD	µg/kg	LB	6.1 T	µg/kg	B	None	Analyte detected in associated blank; sample concentration greater than five times the blank concentration
PSS	PSS-060406-1200	04/06/06	SW-846 8270 SIM	Pyrene	2200 D	µg/kg	CVS	29	%	J	None	Datum is estimated, bias unknown; CVS %D outside acceptance criterion
RS	RS-060406-1215	04/06/06	SW-846 8270 SIM	Dibenz(a,h)anthracene	100 TD	µg/kg	LCS	164	%	J	High	Datum is estimated, possible high bias; LCS recovery outside acceptance criteria
RS	RS-060406-1215	04/06/06	SW-846 8270 SIM	Indeno(1,2,3-c,d)pyrene	690 D	µg/kg	LCS	138	%	J	High	Datum is estimated, possible high bias; LCS recovery outside acceptance criteria
RS	RS-060406-1215	04/06/06	SW-846 8082	2,2',3,4',5',6'-Heptachlorobiphenyl	12 D	µg/kg	CVS	17.2	%	J	None	Datum is estimated, bias unknown; CVS %D outside acceptance criterion
RS	RS-060406-1215	04/06/06	SW-846 8082	2,2',3,4,4',5,5'-Heptachlorobiphenyl	11 D	µg/kg	CONF	49	%	J	None	Datum is estimated, bias unknown; %D between primary and secondary GC columns outside acceptance criterion
RS	RS-060406-1215	04/06/06	SW-846 8082	2,2',3,4,5'-Pentachlorobiphenyl	11 D	µg/kg	CONF	1000	%	J	None	Datum is estimated, bias unknown; %D between primary and secondary GC columns outside acceptance criterion
RS	RS-060406-1215	04/06/06	SW-846 8082	2,2',4,4',5,5'-Hexachlorobiphenyl	22 D	µg/kg	CVS	18.1	%	J	None	Datum is estimated, bias unknown; CVS %D outside acceptance criterion
RS	RS-060406-1215	04/06/06	SW-846 8082	2,2',5,5'-Tetrachlorobiphenyl	38 D	µg/kg	CONF	158	%	J	None	Datum is estimated, bias unknown; %D between primary and secondary GC columns outside acceptance criterion
RS	RS-060406-1215	04/06/06	SW-846 8082	2-Chlorobiphenyl	36 D	µg/kg	CONF	298	%	J	None	Datum is estimated, bias unknown; %D between primary and secondary GC columns outside acceptance criterion
RS	RS-060406-1215	04/06/06	SW-846 8270C	2-Methylphenol (o-Cresol)	2000 TD	µg/kg	LB	6.1 T	µg/kg	B	None	Analyte detected in associated blank; sample concentration greater than five times the blank concentration
RS	RS-060406-1215	04/06/06	SW-846 8290	1,2,3,4,6,7,8-Heptachlorodibenzo-p-dioxin	540	pg/g	LB	0.11 T	pg/g	B	None	Analyte detected in associated blank; sample concentration greater than five times the blank concentration

TABLE 1
DATA QUALIFIERS SUMMARY TABLE
DEMONSTRATION TESTING AND FULL-SCALE OPERATION OF THE BIOGENESIS SEDIMENT DECONTAMINATION PROCESS, KEASBEY, NEW JERSEY
(Page132 of 188)

Location Identification	Sample Identification	Sample Date	Analysis	Analyte	Sample Result	Sample Units	QC Type	QC Result	QC Units	Qualifier	Bias	Comment
RS	RS-060406-1215	04/06/06	SW-846 8290	1,2,3,4,6,7,8-Heptachlorodibenzofuran	360	pg/g	LB	0 071 T	pg/g	B	None	Analyte detected in associated blank; sample concentration greater than five times the blank concentration
RS	RS-060406-1215	04/06/06	SW-846 8290	1,2,3,4,7,8,9-Heptachlorodibenzofuran	29	pg/g	PDE	N/A	N/A	J	None	Datum is estimated, bias unknown; interfering polychlorinated diphenyl ether peak present
RS	RS-060406-1215	04/06/06	SW-846 8290	1,2,3,4,7,8-Hexachlorodibenzo-p-dioxin	9 2 T	pg/g	IAR	0 82	N/A	J	None	Datum is estimated, bias unknown; ion abundance ratio outside acceptance criteria
RS	RS-060406-1215	04/06/06	SW-846 8290	1,2,3,6,7,8-Hexachlorodibenzofuran	31	pg/g	PDE LB	N/A 0 050 T	N/A pg/g	JB	None	Datum is estimated, bias unknown; interfering polychlorinated diphenyl ether peak present Analyte detected in associated blank; sample concentration greater than five times the blank concentration
RS	RS-060406-1215	04/06/06	SW-846 8290	1,2,3,7,8,9-Hexachlorodibenzo-p-Dioxin	20	pg/g	IAR	0 95	N/A	J	None	Datum is estimated, bias unknown; ion abundance ratio outside acceptance criteria
RS	RS-060406-1215	04/06/06	SW-846 8290	1,2,3,7,8,9-Hexachlorodibenzofuran	4 6 T	pg/g	PDE	N/A	N/A	J	None	Datum is estimated, bias unknown; interfering polychlorinated diphenyl ether peak present
RS	RS-060406-1215	04/06/06	SW-846 8290	1,2,3,7,8-Pentachlorodibenzo-p-dioxin	6 7 T	pg/g	IAR	0 85	N/A	J	None	Datum is estimated, bias unknown; ion abundance ratio outside acceptance criteria
RS	RS-060406-1215	04/06/06	SW-846 8290	1,2,3,7,8-Pentachlorodibenzofuran	16	pg/g	PDE	N/A	N/A	J	None	Datum is estimated, bias unknown; interfering polychlorinated diphenyl ether peak present
RS	RS-060406-1215	04/06/06	SW-846 8290	2,3,4,7,8-Pentachlorodibenzofuran	23	pg/g	PDE	N/A	N/A	J	None	Datum is estimated, bias unknown; interfering polychlorinated diphenyl ether peak present
RS	RS-060406-1215	04/06/06	SW-846 8290	Octachlorodibenzo-p-dioxin	6500	pg/g	LB	0 70 T	pg/g	B	None	Analyte detected in associated blank; sample concentration greater than five times the blank concentration
RS	RS-060406-1215	04/06/06	SW-846 8290	Octachlorodibenzofuran	520	pg/g	LB	0 20 T	pg/g	B	None	Analyte detected in associated blank; sample concentration greater than five times the blank concentration
RS	RS-060406-1215	04/06/06	SW-846 8270 SIM	Pyrene	10000 D	µg/kg	CVS	29	%	J	None	Datum is estimated, bias unknown; CVS %D outside acceptance criterion
RS	RS-060406-1215	04/06/06	SW-846 8081A	Dieldrin	9 2	µg/kg	CONF	1000	%	J	None	Datum is estimated, bias unknown; %D between primary and secondary GC columns outside acceptance criterion
RS	RS-060406-1215	04/06/06	SW-846 8081A	beta Endosulfan	24	µg/kg	CONF	130	%	J	None	Datum is estimated, bias unknown; %D between primary and secondary GC columns outside acceptance criterion
RS	RS-060406-1215	04/06/06	SW-846 8081A	Alpha-Chlordane	17	µg/kg	CONF	656	%	J	None	Datum is estimated, bias unknown; %D between primary and secondary GC columns outside acceptance criterion
RS	RS-060406-1215	04/06/06	SW-846 8081A	Gamma-Chlordane	14	µg/kg	CONF	45 6	%	J	None	Datum is estimated, bias unknown; %D between primary and secondary GC columns outside acceptance criterion
RS	RS-060406-1215	04/06/06	SW-846 8081A	Aldrin	6 9	µg/kg	CONF	460	%	J	None	Datum is estimated, bias unknown; %D between primary and secondary GC columns outside acceptance criterion

TABLE 1
DATA QUALIFIERS SUMMARY TABLE
DEMONSTRATION TESTING AND FULL-SCALE OPERATION OF THE BIOGENESIS SEDIMENT DECONTAMINATION PROCESS, KEASBEY, NEW JERSEY
(Page133 of 188)

Location Identification	Sample Identification	Sample Date	Analysis	Analyte	Sample Result	Sample Units	QC Type	QC Result	QC Units	Qualifier	Bias	Comment
SS1	SS1-060406-1205	04/06/06	SW-846 8270 SIM	Dibenz(a,h)anthracene	740 D	µg/kg	LCS	164	%	J	High	Datum is estimated, possible high bias; LCS recovery outside acceptance criteria
SS1	SS1-060406-1205	04/06/06	SW-846 8270 SIM	Indeno(1,2,3-c,d)pyrene	1900 D	µg/kg	LCS	138	%	J	High	Datum is estimated, possible high bias; LCS recovery outside acceptance criteria
SS1	SS1-060406-1205	04/06/06	SW-846 8270C	2-Methylphenol (o-Cresol)	1700 TD	µg/kg	LB	6 1 T	µg/kg	B	None	Analyte detected in associated blank; sample concentration greater than five times the blank concentration
SS1	SS1-060406-1205	04/06/06	SW-846 8270 SIM	Pyrene	9300 D	µg/kg	CVS	29	%	J	None	Datum is estimated, bias unknown; CVS %D outside acceptance criterion
SS2	SS2-060406-1210	04/06/06	SW-846 8270 SIM	Dibenz(a,h)anthracene	910 D	µg/kg	LCS	164	%	J	High	Datum is estimated, possible high bias; LCS recovery outside acceptance criteria
SS2	SS2-060406-1210	04/06/06	SW-846 8270 SIM	Indeno(1,2,3-c,d)pyrene	2900 D	µg/kg	LCS	138	%	J	High	Datum is estimated, possible high bias; LCS recovery outside acceptance criteria
SS2	SS2-060406-1210	04/06/06	SW-846 8270C	2-Methylphenol (o-Cresol)	1900 TD	µg/kg	LB	6 1 T	µg/kg	B	None	Analyte detected in associated blank; sample concentration greater than five times the blank concentration
SS2	SS2-060406-1210	04/06/06	SW-846 8270 SIM	Pyrene	2100 D	µg/kg	CVS	29	%	J	None	Datum is estimated, bias unknown; CVS %D outside acceptance criterion
TS	TS-060406-1240	04/06/06	SW-846 8270 SIM	Chrysene	2000 D	µg/kg	MSD	132	%	J	High	Datum is estimated, possible high bias; MSD recovery outside acceptance criteria
TS	TS-060406-1240	04/06/06	SW-846 8270 SIM	Dibenz(a,h)anthracene	260 D	µg/kg	LCS	164	%	J	High	Datum is estimated, possible high bias; LCS recovery outside acceptance criteria
TS	TS-060406-1240	04/06/06	SW-846 8270 SIM	Fluoranthene	2400 D	µg/kg	MS MSD	146 166	%	J	High	Datum is estimated, possible high bias; MS/MSD recoveries outside acceptance criteria
TS	TS-060406-1240	04/06/06	SW-846 8270 SIM	Indeno(1,2,3-c,d)pyrene	780 D	µg/kg	LCS	138	%	J	High	Datum is estimated, possible high bias; LCS recovery outside acceptance criteria
TS	TS-060406-1240	04/06/06	SW-846 8082	2,2',3,3',4,4',5,5',6-Nonachlorobiphenyl	2 5 D	µg/kg	MSD	242	%	J	High	Datum is estimated, possible high bias; MSD recovery outside acceptance criteria
TS	TS-060406-1240	04/06/06	SW-846 8082	2,2',3,4',5,5',6-Heptachlorobiphenyl	7 4 D	µg/kg	CVS	17 2	%	J	None	Datum is estimated, bias unknown; CVS %D outside acceptance criterion
TS	TS-060406-1240	04/06/06	SW-846 8082	2,2',3,4,4',5,5'-Heptachlorobiphenyl	6 9 D	µg/kg	MS CONF	261 46 8	%	J	High	Datum is estimated, possible high bias; MS recovery and %D between primary and secondary GC columns outside acceptance criteria
TS	TS-060406-1240	04/06/06	SW-846 8082	2,2',3,4,5'-Pentachlorobiphenyl	6 2 D	µg/kg	CONF	1000	%	J	None	Datum is estimated, bias unknown; %D between primary and secondary GC columns outside acceptance criterion
TS	TS-060406-1240	04/06/06	SW-846 8082	2,2',4,4',5,5'-Hexachlorobiphenyl	14 D	µg/kg	MSD CVS	152 18 1	%	J	High	Datum is estimated, possible high bias; MSD recovery and CVS %D outside acceptance criteria

TABLE 1
DATA QUALIFIERS SUMMARY TABLE
DEMONSTRATION TESTING AND FULL-SCALE OPERATION OF THE BIOGENESIS SEDIMENT DECONTAMINATION PROCESS, KEASBEY, NEW JERSEY
(Page134 of 188)

Location Identification	Sample Identification	Sample Date	Analysis	Analyte	Sample Result	Sample Units	QC Type	QC Result	QC Units	Qualifier	Bias	Comment
TS	TS-060406-1240	04/06/06	SW-846 8082	2,2',5,5'-Tetrachlorobiphenyl	24 D	µg/kg	MS MSD CONF	218 169 254	%	J	High	Datum is estimated, possible high bias; MS/MSD recoveries and %D between primary and secondary GC columns outside acceptance criteria
TS	TS-060406-1240	04/06/06	SW-846 8082	2,2',5-Trichlorobiphenyl	29 D	µg/kg	MS MSD	217 31	%	J	High	Datum is estimated, possible high bias; MS/MSD recoveries outside acceptance criteria
TS	TS-060406-1240	04/06/06	SW-846 8082	2,3',4,4'-Tetrachlorobiphenyl	28 D	µg/kg	MS MSD	273 165	%	J	High	Datum is estimated, possible high bias; MS/MSD recoveries outside acceptance criteria
TS	TS-060406-1240	04/06/06	SW-846 8082	2-Chlorobiphenyl	18 D	µg/kg	CONF	339	%	J	None	Datum is estimated, bias unknown; %D between primary and secondary GC columns outside acceptance criterion
TS	TS-060406-1240	04/06/06	SW-846 8270C	2,4,5-Trichlorophenol	<5100 D	µg/kg	MS	43	%	UJ	Low	Possible false negative; MS recovery outside acceptance criteria
TS	TS-060406-1240	04/06/06	SW-846 8270C	2,4,6-Trichlorophenol	<5100 D	µg/kg	MS	41	%	UJ	Low	Possible false negative; MS recovery outside acceptance criteria
TS	TS-060406-1240	04/06/06	SW-846 8270C	2-Methylphenol (o-Cresol)	1400 TD	µg/kg	LB	6 1 T	µg/kg	B	None	Analyte detected in associated blank; sample concentration greater than five times the blank concentration
TS	TS-060406-1240	04/06/06	SW-846 8270C	Benzo(b)fluoranthene	800 TD	µg/kg	MS	38	%	J	Low	Datum is estimated, possible low bias; MS recovery outside acceptance criteria
TS	TS-060406-1240	04/06/06	SW-846 8270C	Benzo(k)fluoranthene	360 TD	µg/kg	MS	40	%	J	Low	Datum is estimated, possible low bias; MS recovery outside acceptance criteria
TS	TS-060406-1240	04/06/06	SW-846 8270C	Dibenz(a,h)anthracene	<5100 D	µg/kg	MS	44	%	UJ	Low	Possible false negative; MS recovery outside acceptance criteria
TS	TS-060406-1240	04/06/06	SW-846 8270C	Fluoranthene	2400 TD	µg/kg	MSD	162	%	J	High	Datum is estimated, possible high bias; MSD recovery outside acceptance criteria
TS	TS-060406-1240	04/06/06	SW-846 8270C	Fluorene	200 TD	µg/kg	MS	46	%	J	Low	Datum is estimated, possible low bias; MS recovery outside acceptance criteria
TS	TS-060406-1240	04/06/06	SW-846 8270C	Hexachlorobenzene	<5100 D	µg/kg	MS	39	%	UJ	Low	Possible false negative; MS recovery outside acceptance criteria
TS	TS-060406-1240	04/06/06	SW-846 8270C	Hexachloroethane	<5100 D	µg/kg	MS	31	%	UJ	Low	Possible false negative; MS recovery outside acceptance criteria
TS	TS-060406-1240	04/06/06	SW-846 8290	1,2,3,4,6,7,8-Heptachlorodibenzo-p-dioxin	34	pg/g	LB	0 11 T	pg/g	B	None	Analyte detected in associated blank; sample concentration greater than five times the blank concentration
TS	TS-060406-1240	04/06/06	SW-846 8290	1,2,3,4,6,7,8-Heptachlorodibenzofuran	28	pg/g	LB	0 071 T	pg/g	B	None	Analyte detected in associated blank; sample concentration greater than five times the blank concentration
TS	TS-060406-1240	04/06/06	SW-846 8290	1,2,3,4,7,8-Hexachlorodibenzo-p-dioxin	0 46 T	pg/g	IAR	0 79	N/A	J	None	Datum is estimated, bias unknown; ion abundance ratio outside acceptance criteria

TABLE 1
DATA QUALIFIERS SUMMARY TABLE
DEMONSTRATION TESTING AND FULL-SCALE OPERATION OF THE BIOGENESIS SEDIMENT DECONTAMINATION PROCESS, KEASBEY, NEW JERSEY
(Page135 of 188)

Location Identification	Sample Identification	Sample Date	Analysis	Analyte	Sample Result	Sample Units	QC Type	QC Result	QC Units	Qualifier	Bias	Comment
TS	TS-060406-1240	04/06/06	SW-846 8290	1,2,3,6,7,8-Hexachlorodibenzofuran	3.3 T	pg/g	LB	0.050 T	pg/g	B	None	Analyte detected in associated blank; sample concentration greater than five times the blank concentration
TS	TS-060406-1240	04/06/06	SW-846 8290	1,2,3,7,8,9-Hexachlorodibenzofuran	0.36 T	pg/g	IAR	1.92	N/A	J	None	Datum is estimated, bias unknown; ion abundance ratio outside acceptance criteria
TS	TS-060406-1240	04/06/06	SW-846 8290	1,2,3,7,8-Pentachlorodibenzo-p-dioxin	0.52 T	pg/g	IAR	0.88	N/A	J	None	Datum is estimated, bias unknown; ion abundance ratio outside acceptance criteria
TS	TS-060406-1240	04/06/06	SW-846 8290	2,3,7,8-Tetrachlorodibenzo-p-dioxin	4.3	pg/g	MS	128	%	J	High	Datum is estimated, possible high bias; MS recovery outside acceptance criteria
TS	TS-060406-1240	04/06/06	SW-846 8290	Octachlorodibenzo-p-dioxin	350	pg/g	MS MSD LB	224 434 0.70 T	% % pg/g	JB	High	Datum is estimated, possible high bias; MS/MSD recoveries outside acceptance criteria Analyte detected in associated blank; sample concentration greater than five times blank concentration
TS	TS-060406-1240	04/06/06	SW-846 8290	Octachlorodibenzofuran	47	pg/g	LB	0.20 T	pg/g	B	None	Analyte detected in associated blank; sample concentration greater than five times the blank concentration
TS	TS-060406-1240	04/06/06	SW-846 8270 SIM	Pyrene	2600 D	µg/kg	MS MSD CVS	123 130 29	%	J	High	Datum is estimated, possible high bias; MS/MSD recoveries and CVS %D outside acceptance criteria
TS	TS-060406-1240	04/06/06	SW-846 8081A	p,p'-DDT	610	µg/kg	CONF	93.3	%	J	None	Datum is estimated, bias unknown; %D between primary and secondary GC columns outside acceptance criterion
TS1	TS1-060406-1225	04/06/06	SW-846 8270 SIM	Dibenz(a,h)anthracene	700 D	µg/kg	LCS	164	%	J	High	Datum is estimated, possible high bias; LCS recovery outside acceptance criteria
TS1	TS1-060406-1225	04/06/06	SW-846 8270 SIM	Indeno(1,2,3-c,d)pyrene	2100 D	µg/kg	LCS	138	%	J	High	Datum is estimated, possible high bias; LCS recovery outside acceptance criteria
TS1	TS1-060406-1225	04/06/06	SW-846 8270 SIM	Pyrene	7400 D	µg/kg	CVS	29	%	J	None	Datum is estimated, bias unknown; CVS %D outside acceptance criterion
TS2	TS2-060406-1230	04/06/06	SW-846 8270 SIM	Dibenz(a,h)anthracene	130 D	µg/kg	LCS	164	%	J	High	Datum is estimated, possible high bias; LCS recovery outside acceptance criteria
TS2	TS2-060406-1230	04/06/06	SW-846 8270 SIM	Indeno(1,2,3-c,d)pyrene	430 D	µg/kg	LCS	138	%	J	High	Datum is estimated, possible high bias; LCS recovery outside acceptance criteria
TS2	TS2-060406-1230	04/06/06	SW-846 8270 SIM	Pyrene	1800 D	µg/kg	CVS	29	%	J	None	Datum is estimated, bias unknown; CVS %D outside acceptance criterion
TS3	TS3-060406-1235	04/06/06	SW-846 8270 SIM	Dibenz(a,h)anthracene	120 D	µg/kg	LCS	164	%	J	High	Datum is estimated, possible high bias; LCS recovery outside acceptance criteria
TS3	TS3-060406-1235	04/06/06	SW-846 8270 SIM	Indeno(1,2,3-c,d)pyrene	360 D	µg/kg	LCS	138	%	J	High	Datum is estimated, possible high bias; LCS recovery outside acceptance criteria

TABLE 1
DATA QUALIFIERS SUMMARY TABLE
DEMONSTRATION TESTING AND FULL-SCALE OPERATION OF THE BIOGENESIS SEDIMENT DECONTAMINATION PROCESS, KEASBEY, NEW JERSEY
(Page136 of 188)

Location Identification	Sample Identification	Sample Date	Analysis	Analyte	Sample Result	Sample Units	QC Type	QC Result	QC Units	Qualifier	Bias	Comment
TS3	TS3-060406-1235	04/06/06	SW-846 8270 SIM	Pyrene	1200 D	µg/kg	CVS	29	%	J	None	Datum is estimated, bias unknown; CVS %D outside acceptance criterion
WS	WS-060406-1300	04/06/06	SW-846 8270 SIM	Dibenz(a,h)anthracene	63 TD	µg/kg	LCS	164	%	J	High	Datum is estimated, possible high bias; LCS recovery outside acceptance criteria
WS	WS-060406-1300	04/06/06	SW-846 8270 SIM	Indeno(1,2,3-c,d)pyrene	190 D	µg/kg	LCS	138	%	J	High	Datum is estimated, possible high bias; LCS recovery outside acceptance criteria
WS	WS-060406-1300	04/06/06	SW-846 8082	2,2',3,4',5,5',6-Heptachlorobiphenyl	26 D	µg/kg	CVS	17.2	%	J	None	Datum is estimated, bias unknown; CVS %D outside acceptance criterion
WS	WS-060406-1300	04/06/06	SW-846 8082	2,2',3,4,5'-Pentachlorobiphenyl	23 D	µg/kg	CONF	1000	%	J	None	Datum is estimated, bias unknown; %D between primary and secondary GC columns outside acceptance criterion
WS	WS-060406-1300	04/06/06	SW-846 8082	2,2',4,4',5,5'-Hexachlorobiphenyl	45 D	µg/kg	CVS	18.1	%	J	None	Datum is estimated, bias unknown; CVS %D outside acceptance criterion
WS	WS-060406-1300	04/06/06	SW-846 8082	2,2',5,5'-Tetrachlorobiphenyl	85 D	µg/kg	CONF	153	%	J	None	Datum is estimated, bias unknown; %D between primary and secondary GC columns outside acceptance criterion
WS	WS-060406-1300	04/06/06	SW-846 8082	2,3-Dichlorobiphenyl	15 D	µg/kg	CONF	166	%	J	None	Datum is estimated, bias unknown; %D between primary and secondary GC columns outside acceptance criterion
WS	WS-060406-1300	04/06/06	SW-846 8270C	2-Methylphenol (o-Cresol)	3500 TD	µg/kg	LB	6.1 T	µg/kg	B	None	Analyte detected in associated blank; sample concentration greater than five times the blank concentration
WS	WS-060406-1300	04/06/06	SW-846 8290	1,2,3,4,6,7,8-Heptachlorodibenzo-p-dioxin	120	pg/g	LB	0.11 T	pg/g	B	None	Analyte detected in associated blank; sample concentration greater than five times the blank concentration
WS	WS-060406-1300	04/06/06	SW-846 8290	1,2,3,4,6,7,8-Heptachlorodibenzofuran	76	pg/g	LB	0.071 T	pg/g	B	None	Analyte detected in associated blank; sample concentration greater than five times the blank concentration
WS	WS-060406-1300	04/06/06	SW-846 8290	1,2,3,4,7,8-Hexachlorodibenzo-p-dioxin	1.3 T	pg/g	IAR	0.91	N/A	J	None	Datum is estimated, bias unknown; ion abundance ratio outside acceptance criteria
WS	WS-060406-1300	04/06/06	SW-846 8290	1,2,3,6,7,8-Hexachlorodibenzofuran	5.7 T	pg/g	LB	0.050 T	pg/g	B	None	Analyte detected in associated blank; sample concentration greater than five times the blank concentration
WS	WS-060406-1300	04/06/06	SW-846 8290	1,2,3,7,8-Pentachlorodibenzo-p-dioxin	1.5 T	pg/g	IAR	0.88	N/A	J	None	Datum is estimated, bias unknown; ion abundance ratio outside acceptance criteria
WS	WS-060406-1300	04/06/06	SW-846 8290	1,2,3,7,8-Pentachlorodibenzofuran	3.6 T	pg/g	PDE	N/A	N/A	J	None	Datum is estimated, bias unknown; interfering polychlorinated diphenyl ether peak present
WS	WS-060406-1300	04/06/06	SW-846 8290	2,3,4,6,7,8-Hexachlorodibenzofuran	3.6 T	pg/g	IAR	1.51	N/A	J	None	Datum is estimated, bias unknown; ion abundance ratio outside acceptance criteria

TABLE 1
DATA QUALIFIERS SUMMARY TABLE
DEMONSTRATION TESTING AND FULL-SCALE OPERATION OF THE BIOGENESIS SEDIMENT DECONTAMINATION PROCESS, KEASBEY, NEW JERSEY
(Page137 of 188)

Location Identification	Sample Identification	Sample Date	Analysis	Analyte	Sample Result	Sample Units	QC Type	QC Result	QC Units	Qualifier	Bias	Comment
WS	WS-060406-1300	04/06/06	SW-846 8290	Octachlorodibenzo-p-dioxin	1400	pg/g	LB	0 70 T	pg/g	B	None	Analyte detected in associated blank; sample concentration greater than five times the blank concentration
WS	WS-060406-1300	04/06/06	SW-846 8290	Octachlorodibenzofuran	120	pg/g	LB	0 20 T	pg/g	B	None	Analyte detected in associated blank; sample concentration greater than five times the blank concentration
WS	WS-060406-1300	04/06/06	SW-846 8270 SIM	Pyrene	1100 D	µg/kg	CVS	29	%	J	None	Datum is estimated, bias unknown; CVS %D outside acceptance criterion
WS	WS-060406-1300	04/06/06	SW-846 8081A	Endrin	31	µg/kg	CONF	80	%	J	None	Datum is estimated, bias unknown; %D between primary and secondary GC columns outside acceptance criterion
WS	WS-060406-1300	04/06/06	SW-846 8081A	Alpha-Chlordane	15	µg/kg	CONF	311	%	J	None	Datum is estimated, bias unknown; %D between primary and secondary GC columns outside acceptance criterion
PSS	PSS-100406-1510	04/10/06	SW-846 8270 SIM	Benzo(a)pyrene	1400 D	µg/kg	LCS	126	%	J	High	Datum is estimated, possible high bias; LCS recovery outside acceptance criteria
PSS	PSS-100406-1510	04/10/06	SW-846 8270 SIM	Pyrene	3000 D	µg/kg	CVS	29	%	J	None	Datum is estimated, bias unknown; CVS %D outside acceptance criterion
PSS	PSS-100406-1510	04/10/06	SW-846 8270 SIM	Benzo(k)fluoranthene	780 D	µg/kg	LCS	130	%	J	High	Datum is estimated, possible high bias; LCS recovery outside acceptance criteria
PSS	PSS-100406-1510	04/10/06	SW-846 8270 SIM	Dibenz(a,h)anthracene	360 D	µg/kg	LCS	182	%	J	High	Datum is estimated, possible high bias; LCS recovery outside acceptance criteria
PSS	PSS-100406-1510	04/10/06	SW-846 8270 SIM	Indeno(1,2,3-c,d)pyrene	810 D	µg/kg	LCS	164	%	J	High	Datum is estimated, possible high bias; LCS recovery outside acceptance criteria
PSS	PSS-100406-1510	04/10/06	SW-846 6010B	Chromium, total	174	mg/kg	MS	169	%	J	High	Datum is estimated, possible high bias; MS recovery outside acceptance criteria
PSS	PSS-100406-1510	04/10/06	SW-846 6010B	Lead	245	mg/kg	MS SLD	132 11 2	%	J	High	Datum is estimated, possible high bias; MS recovery and serial dilution %D outside acceptance criteria
PSS	PSS-100406-1510	04/10/06	SW-846 6010B	Nickel	47	mg/kg	SLD	10 1	%	J	None	Datum is estimated, bias unknown; serial dilution %D outside acceptance criterion
PSS	PSS-100406-1510	04/10/06	SW-846 6010B	Selenium	2 3	mg/kg	SLD	60 8	%	J	None	Datum is estimated, bias unknown; serial dilution %D outside acceptance criterion
PSS	PSS-100406-1510	04/10/06	SW-846 6010B	Zinc	417	mg/kg	SLD	13 1	%	J	None	Datum is estimated, bias unknown; serial dilution %D outside acceptance criterion
RS	RS-100406-1525	04/10/06	SW-846 8270 SIM	Benzo(a)pyrene	1300 D	µg/kg	LCS	126	%	J	High	Datum is estimated, possible high bias; LCS recovery outside acceptance criteria
RS	RS-100406-1525	04/10/06	SW-846 8270 SIM	Pyrene	2500 D	µg/kg	CVS	29	%	J	None	Datum is estimated, bias unknown; CVS %D outside acceptance criterion

TABLE 1
DATA QUALIFIERS SUMMARY TABLE
DEMONSTRATION TESTING AND FULL-SCALE OPERATION OF THE BIOGENESIS SEDIMENT DECONTAMINATION PROCESS, KEASBEY, NEW JERSEY
(Page138 of 188)

Location Identification	Sample Identification	Sample Date	Analysis	Analyte	Sample Result	Sample Units	QC Type	QC Result	QC Units	Qualifier	Bias	Comment
RS	RS-100406-1525	04/10/06	SW-846 8270 SIM	Benzo(k)fluoranthene	660 D	µg/kg	LCS	130	%	J	High	Datum is estimated, possible high bias; LCS recovery outside acceptance criteria
RS	RS-100406-1525	04/10/06	SW-846 8270 SIM	Dibenz(a,h)anthracene	260 D	µg/kg	LCS	182	%	J	High	Datum is estimated, possible high bias; LCS recovery outside acceptance criteria
RS	RS-100406-1525	04/10/06	SW-846 8270 SIM	Indeno(1,2,3-c,d)pyrene	730 D	µg/kg	LCS	164	%	J	High	Datum is estimated, possible high bias; LCS recovery outside acceptance criteria
RS	RS-100406-1525	04/10/06	SW-846 8082	2,2',3,4,4',5,5'-Heptachlorobiphenyl	13 D	µg/kg	CONF	40 8	%	J	None	Datum is estimated, bias unknown; %D between primary and secondary GC columns outside acceptance criterion
RS	RS-100406-1525	04/10/06	SW-846 8082	2,2',3,4,5'-Pentachlorobiphenyl	13 D	µg/kg	CONF	1000	%	J	None	Datum is estimated, bias unknown; %D between primary and secondary GC columns outside acceptance criterion
RS	RS-100406-1525	04/10/06	SW-846 8082	2,2',5,5'-Tetrachlorobiphenyl	45 D	µg/kg	CONF	134	%	J	None	Datum is estimated, bias unknown; %D between primary and secondary GC columns outside acceptance criterion
RS	RS-100406-1525	04/10/06	SW-846 8082	2-Chlorobiphenyl	43 TD	µg/kg	CONF	133	%	J	None	Datum is estimated, bias unknown; %D between primary and secondary GC columns outside acceptance criterion
RS	RS-100406-1525	04/10/06	SW-846 8290	1,2,3,4,6,7,8-Heptachlorodibenzo-p-dioxin	600	pg/g	LB	0 11 T	pg/g	B	None	Analyte detected in associated blank; sample concentration greater than five times the blank concentration
RS	RS-100406-1525	04/10/06	SW-846 8290	1,2,3,4,6,7,8-Heptachlorodibenzofuran	380	pg/g	LB	0 071 T	pg/g	B	None	Analyte detected in associated blank; sample concentration greater than five times the blank concentration
RS	RS-100406-1525	04/10/06	SW-846 8290	1,2,3,4,7,8,9-Heptachlorodibenzofuran	27	pg/g	IAR	1 25	N/A	J	None	Datum is estimated, bias unknown; ion abundance ratio outside acceptance criteria
RS	RS-100406-1525	04/10/06	SW-846 8290	1,2,3,4,7,8-Hexachlorodibenzo-p-dioxin	9 2 T	pg/g	IAR	0 81	N/A	J	None	Datum is estimated, bias unknown; ion abundance ratio outside acceptance criteria
RS	RS-100406-1525	04/10/06	SW-846 8290	1,2,3,6,7,8-Hexachlorodibenzofuran	27	pg/g	PDE LB	N/A 0 050 T	N/A pg/g	JB	None	Datum is estimated, bias unknown; interfering polychlorinated diphenyl ether peak present Analyte detected in associated blank; sample concentration greater than five times the blank concentration
RS	RS-100406-1525	04/10/06	SW-846 8290	1,2,3,7,8,9-Hexachlorodibenzo-p-Dioxin	20	pg/g	IAR	0 81	N/A	J	None	Datum is estimated, bias unknown; ion abundance ratio outside acceptance criteria
RS	RS-100406-1525	04/10/06	SW-846 8290	1,2,3,7,8,9-Hexachlorodibenzofuran	5 6 T	pg/g	IAR	1 65	N/A	J	None	Datum is estimated, bias unknown; ion abundance ratio outside acceptance criteria
RS	RS-100406-1525	04/10/06	SW-846 8290	1,2,3,7,8-Pentachlorodibenzo-p-dioxin	6 5 T	pg/g	IAR	0 68	N/A	J	None	Datum is estimated, bias unknown; ion abundance ratio outside acceptance criteria
RS	RS-100406-1525	04/10/06	SW-846 8290	2,3,4,7,8-Pentachlorodibenzofuran	23	pg/g	PDE	N/A	N/A	J	None	Datum is estimated, bias unknown; interfering polychlorinated diphenyl ether peak present

TABLE 1
DATA QUALIFIERS SUMMARY TABLE
DEMONSTRATION TESTING AND FULL-SCALE OPERATION OF THE BIOGENESIS SEDIMENT DECONTAMINATION PROCESS, KEASBEY, NEW JERSEY
(Page139 of 188)

Location Identification	Sample Identification	Sample Date	Analysis	Analyte	Sample Result	Sample Units	QC Type	QC Result	QC Units	Qualifier	Bias	Comment
RS	RS-100406-1525	04/10/06	SW-846 8290	Octachlorodibenzo-p-dioxin	7100	pg/g	LB	0 70 T	pg/g	B	None	Analyte detected in associated blank; sample concentration greater than five times the blank concentration
RS	RS-100406-1525	04/10/06	SW-846 8290	Octachlorodibenzofuran	570	pg/g	LB	0 20 T	pg/g	B	None	Analyte detected in associated blank; sample concentration greater than five times the blank concentration
RS	RS-100406-1525	04/10/06	SW-846 8081A	p,p'-DDD	210 TD	µg/kg	CVS CONF	18 19 378	%	J	None	Datum is estimated, bias unknown; CVS %D and %D between primary and secondary GC columns outside acceptance criteria
RS	RS-100406-1525	04/10/06	SW-846 8081A	beta Endosulfan	63	µg/kg	CONF	41 5	%	J	None	Datum is estimated, bias unknown; %D between primary and secondary GC columns outside acceptance criterion
RS	RS-100406-1525	04/10/06	SW-846 8081A	Endrin	30	µg/kg	CONF	132	%	J	None	Datum is estimated, bias unknown; %D between primary and secondary GC columns outside acceptance criterion
RS	RS-100406-1525	04/10/06	SW-846 8081A	p,p'-DDD	210	µg/kg	CONF	378	%	J	None	Datum is estimated, bias unknown; %D between primary and secondary GC columns outside acceptance criterion
SS1	SS1-100406-1515	04/10/06	SW-846 8270 SIM	Benzo(a)pyrene	1200 D	µg/kg	LCS	126	%	J	High	Datum is estimated, possible high bias; LCS recovery outside acceptance criteria
SS1	SS1-100406-1515	04/10/06	SW-846 8270 SIM	Pyrene	2500 D	µg/kg	CVS	29	%	J	None	Datum is estimated, bias unknown; CVS %D outside acceptance criterion
SS1	SS1-100406-1515	04/10/06	SW-846 8270 SIM	Benzo(k)fluoranthene	580 D	µg/kg	LCS	130	%	J	High	Datum is estimated, possible high bias; LCS recovery outside acceptance criteria
SS1	SS1-100406-1515	04/10/06	SW-846 8270 SIM	Dibenz(a,h)anthracene	210 D	µg/kg	LCS	182	%	J	High	Datum is estimated, possible high bias; LCS recovery outside acceptance criteria
SS1	SS1-100406-1515	04/10/06	SW-846 8270 SIM	Indeno(1,2,3-c,d)pyrene	570 D	µg/kg	LCS	164	%	J	High	Datum is estimated, possible high bias; LCS recovery outside acceptance criteria
SS2	SS2-100406-1520	04/10/06	SW-846 8270 SIM	Benzo(a)pyrene	5000 D	µg/kg	LCS	126	%	J	High	Datum is estimated, possible high bias; LCS recovery outside acceptance criteria
SS2	SS2-100406-1520	04/10/06	SW-846 8270 SIM	Pyrene	11000 D	µg/kg	CVS	29	%	J	None	Datum is estimated, bias unknown; CVS %D outside acceptance criterion
SS2	SS2-100406-1520	04/10/06	SW-846 8270 SIM	Benzo(k)fluoranthene	2100 D	µg/kg	LCS	130	%	J	High	Datum is estimated, possible high bias; LCS recovery outside acceptance criteria
SS2	SS2-100406-1520	04/10/06	SW-846 8270 SIM	Dibenz(a,h)anthracene	850 D	µg/kg	LCS	182	%	J	High	Datum is estimated, possible high bias; LCS recovery outside acceptance criteria
SS2	SS2-100406-1520	04/10/06	SW-846 8270 SIM	Indeno(1,2,3-c,d)pyrene	2500 D	µg/kg	LCS	164	%	J	High	Datum is estimated, possible high bias; LCS recovery outside acceptance criteria
TS	TS-100406-1615	04/10/06	SW-846 8270 SIM	Anthracene	590 D	µg/kg	IS	<50		J	None	Datum is estimated, bias unknown; IS area recovery outside acceptance criteria

TABLE 1
DATA QUALIFIERS SUMMARY TABLE
DEMONSTRATION TESTING AND FULL-SCALE OPERATION OF THE BIOGENESIS SEDIMENT DECONTAMINATION PROCESS, KEASBEY, NEW JERSEY
(Page 140 of 188)

Location Identification	Sample Identification	Sample Date	Analysis	Analyte	Sample Result	Sample Units	QC Type	QC Result	QC Units	Qualifier	Bias	Comment
TS	TS-100406-1615	04/10/06	SW-846 8270 SIM	Benzo(a)anthracene	1200 D	µg/kg	IS	<50		J	None	Datum is estimated, bias unknown; IS area recovery outside acceptance criteria
TS	TS-100406-1615	04/10/06	SW-846 8270 SIM	Chrysene	1500 D	µg/kg	IS	<50		J	None	Datum is estimated, bias unknown; IS area recovery outside acceptance criteria
TS	TS-100406-1615	04/10/06	SW-846 8270 SIM	Fluoranthene	1800 D	µg/kg	IS	<50		J	None	Datum is estimated, bias unknown; IS area recovery outside acceptance criteria
TS	TS-100406-1615	04/10/06	SW-846 8270 SIM	Phenanthrene	990 D	µg/kg	IS	<50		J	None	Datum is estimated, bias unknown; IS area recovery outside acceptance criteria
TS	TS-100406-1615	04/10/06	SW-846 8270 SIM	Pyrene	1800 D	µg/kg	CVS IS	29 0 <50	%	J	Low	Datum is estimated, possible low bias; IS area and CVS %D outside acceptance criteria
TS	TS-100406-1615	04/10/06	SW-846 8082	2,2',3,4,4',5,5'-Heptachlorobiphenyl	6 D	µg/kg	CONF	42 4	%	J	None	Datum is estimated, bias unknown; %D between primary and secondary GC columns outside acceptance criterion
TS	TS-100406-1615	04/10/06	SW-846 8082	2,2',3,4,5'-Pentachlorobiphenyl	6 D	µg/kg	CONF	1000	%	J	None	Datum is estimated, bias unknown; %D between primary and secondary GC columns outside acceptance criterion
TS	TS-100406-1615	04/10/06	SW-846 8082	2,2',5,5'-Tetrachlorobiphenyl	21 D	µg/kg	CONF	178	%	J	None	Datum is estimated, bias unknown; %D between primary and secondary GC columns outside acceptance criterion
TS	TS-100406-1615	04/10/06	SW-846 8082	2,3-Dichlorobiphenyl	4 6 D	µg/kg	CONF	194	%	J	None	Datum is estimated, bias unknown; %D between primary and secondary GC columns outside acceptance criterion
TS	TS-100406-1615	04/10/06	SW-846 8082	2-Chlorobiphenyl	19 TD	µg/kg	CONF	390	%	J	None	Datum is estimated, bias unknown; %D between primary and secondary GC columns outside acceptance criterion
TS	TS-100406-1615	04/10/06	SW-846 8270C	2,4,6-Trichlorophenol	<2500 D	µg/kg	MS	47	%	UJ	Low	Possible false negative; MS recovery outside acceptance criteria
TS	TS-100406-1615	04/10/06	SW-846 8270C	Acenaphthylene	350 TD	µg/kg	MS	38	%	J	Low	Datum is estimated, possible low bias; MS recovery outside acceptance criteria
TS	TS-100406-1615	04/10/06	SW-846 8270C	Anthracene	400 TD	µg/kg	MS	39	%	J	Low	Datum is estimated, possible low bias; MS recovery outside acceptance criteria
TS	TS-100406-1615	04/10/06	SW-846 8270C	Benzo(a)anthracene	810 TD	µg/kg	MS MSD	30 52	%	J	Low	Datum is estimated, possible low bias; MS/MSD recoveries outside acceptance criteria
TS	TS-100406-1615	04/10/06	SW-846 8270C	Benzo(a)pyrene	680 TD	µg/kg	MS MSD	23 39	%	J	Low	Datum is estimated, possible low bias; MS/MSD recoveries outside acceptance criteria
TS	TS-100406-1615	04/10/06	SW-846 8270C	Benzo(b)fluoranthene	620 TD	µg/kg	MS MSD	13 30	%	J	Low	Datum is estimated, possible low bias; MS/MSD recoveries outside acceptance criteria
TS	TS-100406-1615	04/10/06	SW-846 8270C	Benzo(g,h,i)perylene	300 TD	µg/kg	MS MSD	17 23	%	J	Low	Datum is estimated, possible low bias; MS/MSD recoveries outside acceptance criteria
TS	TS-100406-1615	04/10/06	SW-846 8270C	Benzo(k)fluoranthene	280 TD	µg/kg	MS MSD	31 44	%	J	Low	Datum is estimated, possible low bias; MS/MSD recoveries outside acceptance criteria
TS	TS-100406-1615	04/10/06	SW-846 8270C	Chrysene	890 TD	µg/kg	MS	30	%	J	Low	Datum is estimated, possible low bias; MS recovery outside acceptance criteria

TABLE 1
DATA QUALIFIERS SUMMARY TABLE
DEMONSTRATION TESTING AND FULL-SCALE OPERATION OF THE BIOGENESIS SEDIMENT DECONTAMINATION PROCESS, KEASBEY, NEW JERSEY
(Page141 of 188)

Location Identification	Sample Identification	Sample Date	Analysis	Analyte	Sample Result	Sample Units	QC Type	QC Result	QC Units	Qualifier	Bias	Comment
TS	TS-100406-1615	04/10/06	SW-846 8270C	Dibenz(a,h)anthracene	<2500 D	µg/kg	MS MSD	33 36	%	UJ	Low	Possible false negative; MS/MSD recoveries outside acceptance criteria
TS	TS-100406-1615	04/10/06	SW-846 8270C	Fluoranthene	1800 TD	µg/kg	MS	9 9	%	J	Low	Datum is estimated, possible low bias; MS recovery outside acceptance criteria
TS	TS-100406-1615	04/10/06	SW-846 8270C	Hexachlorobenzene	<2500 D	µg/kg	MS	43	%	UJ	Low	Possible false negative; MS recovery outside acceptance criteria
TS	TS-100406-1615	04/10/06	SW-846 8270C	Hexachloroethane	<2500 D	µg/kg	MS MSD	23 31	%	UJ	Low	Possible false negative; MS/MSD recoveries outside acceptance criteria
TS	TS-100406-1615	04/10/06	SW-846 8270C	Indeno(1,2,3-c,d)pyrene	270 TD	µg/kg	MS MSD	27 35	%	J	Low	Datum is estimated, possible low bias; MS/MSD recoveries outside acceptance criteria
TS	TS-100406-1615	04/10/06	SW-846 8270C	Naphthalene	220 TD	µg/kg	MS	40	%	J	Low	Datum is estimated, possible low bias; MS recovery outside acceptance criteria
TS	TS-100406-1615	04/10/06	SW-846 8270C	Pentachlorophenol	<12000 D	µg/kg	MS MSD	0 0	%	UJ	Low	Possible false negative; MS/MSD recoveries outside acceptance criteria
TS	TS-100406-1615	04/10/06	SW-846 8270C	Pyrene	1300 TD	µg/kg	MS	11	%	J	Low	Datum is estimated, possible low bias; MS recovery outside acceptance criteria
TS	TS-100406-1615	04/10/06	SW-846 8290	1,2,3,4,6,7,8-Heptachlorodibenzo-p-dioxin	160	pg/g	LB	0 11 T	pg/g	B	None	Analyte detected in associated blank; sample concentration greater than five times the blank concentration
TS	TS-100406-1615	04/10/06	SW-846 8290	1,2,3,4,6,7,8-Heptachlorodibenzofuran	79	pg/g	LB	0 071 T	pg/g	B	None	Analyte detected in associated blank; sample concentration greater than five times the blank concentration
TS	TS-100406-1615	04/10/06	SW-846 8290	1,2,3,4,7,8,9-Heptachlorodibenzofuran	7 9	pg/g	PDE	N/A	N/A	J	None	Datum is estimated, bias unknown; interfering polychlorinated diphenyl ether peak present
TS	TS-100406-1615	04/10/06	SW-846 8290	1,2,3,6,7,8-Hexachlorodibenzofuran	7 3 T	pg/g	LB	0 050 T	pg/g	B	None	Analyte detected in associated blank; sample concentration greater than five times the blank concentration
TS	TS-100406-1615	04/10/06	SW-846 8290	1,2,3,7,8,9-Hexachlorodibenzofuran	0 47 T	pg/g	PDE	N/A	N/A	J	None	Datum is estimated, bias unknown; interfering polychlorinated diphenyl ether peak present
TS	TS-100406-1615	04/10/06	SW-846 8290	1,2,3,7,8-Pentachlorodibenzofuran	5 8 T	pg/g	PDE	N/A	N/A	J	None	Datum is estimated, bias unknown; interfering polychlorinated diphenyl ether peak present
TS	TS-100406-1615	04/10/06	SW-846 8290	2,3,7,8-Tetrachlorodibenzofuran	11	pg/g	PDE	N/A	N/A	J	None	Datum is estimated, bias unknown; interfering polychlorinated diphenyl ether peak present
TS	TS-100406-1615	04/10/06	SW-846 8290	Octachlorodibenzo-p-dioxin	1600	pg/g	LB	0 70 T	pg/g	B	None	Analyte detected in associated blank; sample concentration greater than five times the blank concentration
TS	TS-100406-1615	04/10/06	SW-846 8290	Octachlorodibenzofuran	130	pg/g	LB	0 20 T	pg/g	B	None	Analyte detected in associated blank; sample concentration greater than five times the blank concentration

TABLE 1
DATA QUALIFIERS SUMMARY TABLE
DEMONSTRATION TESTING AND FULL-SCALE OPERATION OF THE BIOGENESIS SEDIMENT DECONTAMINATION PROCESS, KEASBEY, NEW JERSEY
(Page 142 of 188)

Location Identification	Sample Identification	Sample Date	Analysis	Analyte	Sample Result	Sample Units	QC Type	QC Result	QC Units	Qualifier	Bias	Comment
TS	TS-100406-1615	04/10/06	SW-846 8081A	p,p'-DDD	110 TD	µg/kg	CVS CONF	18 19 470	%	J	None	Datum is estimated, bias unknown; CVS %D and %D between primary and secondary GC columns outside acceptance criteria
TS	TS-100406-1615	04/10/06	SW-846 8081A	p,p'-DDD	110	µg/kg	CONF	470	%	J	None	Datum is estimated, bias unknown; %D between primary and secondary GC columns outside acceptance criterion
TS1	TS1-100406-1600	04/10/06	SW-846 8270 SIM	Benzo(a)pyrene	7000 D	µg/kg	LCS	126	%	J	High	Datum is estimated, possible high bias; LCS recovery outside acceptance criteria
TS1	TS1-100406-1600	04/10/06	SW-846 8270 SIM	Pyrene	11000 D	µg/kg	CVS	29	%	J	None	Datum is estimated, bias unknown; CVS %D outside acceptance criterion
TS1	TS1-100406-1600	04/10/06	SW-846 8270 SIM	Benzo(k)fluoranthene	3200 D	µg/kg	LCS	130	%	J	High	Datum is estimated, possible high bias; LCS recovery outside acceptance criteria
TS1	TS1-100406-1600	04/10/06	SW-846 8270 SIM	Dibenz(a,h)anthracene	1200 D	µg/kg	LCS	182	%	J	High	Datum is estimated, possible high bias; LCS recovery outside acceptance criteria
TS1	TS1-100406-1600	04/10/06	SW-846 8270 SIM	Indeno(1,2,3-c,d)pyrene	3600 D	µg/kg	LCS	164	%	J	High	Datum is estimated, possible high bias; LCS recovery outside acceptance criteria
TS2	TS2-100406-1605	04/10/06	SW-846 8270 SIM	Benzo(a)pyrene	2200 D	µg/kg	LCS	126	%	J	High	Datum is estimated, possible high bias; LCS recovery outside acceptance criteria
TS2	TS2-100406-1605	04/10/06	SW-846 8270 SIM	Pyrene	3800 D	µg/kg	CVS	29	%	J	None	Datum is estimated, bias unknown; CVS %D outside acceptance criterion
TS2	TS2-100406-1605	04/10/06	SW-846 8270 SIM	Benzo(k)fluoranthene	1000 D	µg/kg	LCS	130	%	J	High	Datum is estimated, possible high bias; LCS recovery outside acceptance criteria
TS2	TS2-100406-1605	04/10/06	SW-846 8270 SIM	Dibenz(a,h)anthracene	400 D	µg/kg	LCS	182	%	J	High	Datum is estimated, possible high bias; LCS recovery outside acceptance criteria
TS2	TS2-100406-1605	04/10/06	SW-846 8270 SIM	Indeno(1,2,3-c,d)pyrene	1200 D	µg/kg	LCS	164	%	J	High	Datum is estimated, possible high bias; LCS recovery outside acceptance criteria
TS3	TS3-100406-1610	04/10/06	SW-846 8270 SIM	Benzo(a)pyrene	990 D	µg/kg	LCS	126	%	J	High	Datum is estimated, possible high bias; LCS recovery outside acceptance criteria
TS3	TS3-100406-1610	04/10/06	SW-846 8270 SIM	Pyrene	1800 D	µg/kg	CVS	29	%	J	None	Datum is estimated, bias unknown; CVS %D outside acceptance criterion
TS3	TS3-100406-1610	04/10/06	SW-846 8270 SIM	Benzo(k)fluoranthene	470 D	µg/kg	LCS	130	%	J	High	Datum is estimated, possible high bias; LCS recovery outside acceptance criteria
TS3	TS3-100406-1610	04/10/06	SW-846 8270 SIM	Dibenz(a,h)anthracene	170 D	µg/kg	LCS	182	%	J	High	Datum is estimated, possible high bias; LCS recovery outside acceptance criteria
TS3	TS3-100406-1610	04/10/06	SW-846 8270 SIM	Indeno(1,2,3-c,d)pyrene	530 D	µg/kg	LCS	164	%	J	High	Datum is estimated, possible high bias; LCS recovery outside acceptance criteria

TABLE 1
DATA QUALIFIERS SUMMARY TABLE
DEMONSTRATION TESTING AND FULL-SCALE OPERATION OF THE BIOGENESIS SEDIMENT DECONTAMINATION PROCESS, KEASBEY, NEW JERSEY
(Page 143 of 188)

Location Identification	Sample Identification	Sample Date	Analysis	Analyte	Sample Result	Sample Units	QC Type	QC Result	QC Units	Qualifier	Bias	Comment		
WS	WS-100406-1630	04/10/06	SW-846 8270 SIM	Benzo(a)pyrene	580 D	µg/kg	LCS	126	%	J	High	Datum is estimated, possible high bias; LCS recovery outside acceptance criteria		
WS	WS-100406-1630	04/10/06	SW-846 8270 SIM	Pyrene	1300 D	µg/kg	CVS	29	%	J	None	Datum is estimated, bias unknown; CVS %D outside acceptance criterion		
WS	WS-100406-1630	04/10/06	SW-846 8270 SIM	Benzo(k)fluoranthene	220 D	µg/kg	LCS	130	%	J	High	Datum is estimated, possible high bias; LCS recovery outside acceptance criteria		
WS	WS-100406-1630	04/10/06	SW-846 8270 SIM	Dibenz(a,h)anthracene	92 TD	µg/kg	LCS	182	%	J	High	Datum is estimated, possible high bias; LCS recovery outside acceptance criteria		
WS	WS-100406-1630	04/10/06	SW-846 8270 SIM	Indeno(1,2,3-c,d)pyrene	250 D	µg/kg	LCS	164	%	J	High	Datum is estimated, possible high bias; LCS recovery outside acceptance criteria		
WS	WS-100406-1630	04/10/06	SW-846 8082	2,2',3,4,4',5,5'-Heptachlorobiphenyl	18 D	µg/kg	CONF	50	%	J	None	Datum is estimated, bias unknown; %D between primary and secondary GC columns outside acceptance criterion		
WS	WS-100406-1630	04/10/06	SW-846 8082	2,2',3,4,5'-Pentachlorobiphenyl	17 D	µg/kg	CONF	1000	%	J	None	Datum is estimated, bias unknown; %D between primary and secondary GC columns outside acceptance criterion		
WS	WS-100406-1630	04/10/06	SW-846 8082	2,2',5,5'-Tetrachlorobiphenyl	66 D	µg/kg	CONF	138	%	J	None	Datum is estimated, bias unknown; %D between primary and secondary GC columns outside acceptance criterion		
WS	WS-100406-1630	04/10/06	SW-846 8082	2-Chlorobiphenyl	62 D	µg/kg	CONF	85	%	J	None	Datum is estimated, bias unknown; %D between primary and secondary GC columns outside acceptance criterion		
WS	WS-100406-1630	04/10/06	SW-846 8290	1,2,3,4,6,7,8-Heptachlorodibenzo-p-dioxin	120	pg/g	LB	0.11	T	pg/g	B	None	Analyte detected in associated blank; sample concentration greater than five times the blank concentration	
WS	WS-100406-1630	04/10/06	SW-846 8290	1,2,3,4,6,7,8-Heptachlorodibenzofuran	80	pg/g	LB	0.071	T	pg/g	B	None	Analyte detected in associated blank; sample concentration greater than five times the blank concentration	
WS	WS-100406-1630	04/10/06	SW-846 8290	1,2,3,6,7,8-Hexachlorodibenzofuran	6.2	T	pg/g	LB	0.050	T	pg/g	B	None	Analyte detected in associated blank; sample concentration greater than five times the blank concentration
WS	WS-100406-1630	04/10/06	SW-846 8290	1,2,3,7,8,9-Hexachlorodibenzo-p-Dioxin	4.5	T	pg/g	IAR	1.04	N/A	J	None	Datum is estimated, bias unknown; ion abundance ratio outside acceptance criteria	
WS	WS-100406-1630	04/10/06	SW-846 8290	1,2,3,7,8-Pentachlorodibenzo-p-dioxin	1.3	T	pg/g	IAR	0.72	N/A	J	None	Datum is estimated, bias unknown; ion abundance ratio outside acceptance criteria	
WS	WS-100406-1630	04/10/06	SW-846 8290	Octachlorodibenzo-p-dioxin	1400	pg/g	LB	0.70	T	pg/g	B	None	Analyte detected in associated blank; sample concentration greater than five times the blank concentration	
WS	WS-100406-1630	04/10/06	SW-846 8290	Octachlorodibenzofuran	130	pg/g	LB	0.20	T	pg/g	B	None	Analyte detected in associated blank; sample concentration greater than five times the blank concentration	

TABLE 1
DATA QUALIFIERS SUMMARY TABLE
DEMONSTRATION TESTING AND FULL-SCALE OPERATION OF THE BIOGENESIS SEDIMENT DECONTAMINATION PROCESS, KEASBEY, NEW JERSEY
(Page 144 of 188)

Location Identification	Sample Identification	Sample Date	Analysis	Analyte	Sample Result	Sample Units	QC Type	QC Result	QC Units	Qualifier	Bias	Comment
WS	WS-100406-1630	04/10/06	SW-846 8081A	p,p'-DDD	190 TD	µg/kg	CVS CONF	18 19 445	%	J	None	Datum is estimated, bias unknown; CVS %D and %D between primary and secondary GC columns outside acceptance criteria
WS	WS-100406-1630	04/10/06	SW-846 8081A	Endrin	44	µg/kg	CONF	96 6	%	J	None	Datum is estimated, bias unknown; %D between primary and secondary GC columns outside acceptance criterion
WS	WS-100406-1630	04/10/06	SW-846 8081A	p,p'-DDD	190	µg/kg	CONF	445	%	J	None	Datum is estimated, bias unknown; %D between primary and secondary GC columns outside acceptance criterion
PSS	PSS-110406-1800	04/11/06	Lloyd Kahn	Total organic carbon	44400	mg/kg	CVS	112	%	J	High	Datum is estimated, bias unknown; CVS %D outside acceptance criterion
PSS	PSS-110406-1800	04/11/06	SW-846 6010B	Lead	237	mg/kg	MSD	127	%	J	High	Datum is estimated, possible high bias; MSD recovery outside acceptance criteria
PSS	PSS-110406-1800	04/11/06	SW-846 6010B	Selenium	1 9	mg/kg	SLD	100	%	J	None	Datum is estimated, bias unknown; serial dilution %D outside acceptance criterion
PSS	PSS-110406-1800	04/11/06	SW-846 6010B	Zinc	379	mg/kg	SLD LB	10 4 0 25 T	% mg/kg	JB	None	Datum is estimated, bias unknown; serial dilution percent difference outside acceptance criterion Analyte detected in associated blank; sample concentration greater than five times the blank concentration
RS	RS-110406-1815	04/11/06	Lloyd Kahn	Total organic carbon	49700	mg/kg	CVS	112	%	J	High	Datum is estimated, bias unknown; CVS %D outside acceptance criterion
RS	RS-110406-1815	04/11/06	SW-846 6010B	Zinc	433	mg/kg	LB	0 25 T	mg/kg	B	None	Analyte detected in associated blank; sample concentration greater than five times the blank concentration
SS1	SS1-110406-1805	04/11/06	Lloyd Kahn	Total organic carbon	99500	mg/kg	CVS	112	%	J	High	Datum is estimated, bias unknown; CVS %D outside acceptance criterion
SS1	SS1-110406-1805	04/11/06	SW-846 6010B	Zinc	432	mg/kg	LB	0 25 T	mg/kg	B	None	Analyte detected in associated blank; sample concentration greater than five times the blank concentration
SS2	SS2-110406-1810	04/11/06	Lloyd Kahn	Total organic carbon	127000	mg/kg	CVS	112	%	J	High	Datum is estimated, bias unknown; CVS %D outside acceptance criterion
SS2	SS2-110406-1810	04/11/06	SW-846 6010B	Zinc	276	mg/kg	LB	0 25 T	mg/kg	B	None	Analyte detected in associated blank; sample concentration greater than five times the blank concentration
TS	TS-110406-1835	04/11/06	SW-846 6010B	Zinc	230	mg/kg	LB	0 25 T	mg/kg	B	None	Analyte detected in associated blank; sample concentration greater than five times the blank concentration
TS1	TS1-110406-1820	04/11/06	Lloyd Kahn	Total organic carbon	53500	mg/kg	CVS	112	%	J	High	Datum is estimated, bias unknown; CVS %D outside acceptance criterion

TABLE 1
DATA QUALIFIERS SUMMARY TABLE
DEMONSTRATION TESTING AND FULL-SCALE OPERATION OF THE BIOGENESIS SEDIMENT DECONTAMINATION PROCESS, KEASBEY, NEW JERSEY
(Page 145 of 188)

Location Identification	Sample Identification	Sample Date	Analysis	Analyte	Sample Result	Sample Units	QC Type	QC Result	QC Units	Qualifier	Bias	Comment
TS1	TS1-110406-1820	04/11/06	SW-846 6010B	Zinc	175	mg/kg	LB	0.25 T	mg/kg	B	None	Analyte detected in associated blank; sample concentration greater than five times the blank concentration
TS2	TS2-110406-1825	04/11/06	SW-846 6010B	Zinc	144	mg/kg	LB	0.25 T	mg/kg	B	None	Analyte detected in associated blank; sample concentration greater than five times the blank concentration
TS3	TS3-110406-1830	04/11/06	SW-846 6010B	Zinc	239	mg/kg	LB	0.25 T	mg/kg	B	None	Analyte detected in associated blank; sample concentration greater than five times the blank concentration
WS	WS-110406-1840	04/11/06	SW-846 6010B	Zinc	815	mg/kg	LB	0.25 T	mg/kg	B	None	Analyte detected in associated blank; sample concentration greater than five times the blank concentration
PSS	PSS-120406-1800	04/12/06	SW-846 6010B	Arsenic	26.9	mg/kg	SLD	12.6	%	J	None	Datum is estimated, bias unknown; serial dilution %D outside acceptance criterion
PSS	PSS-120406-1800	04/12/06	SW-846 6010B	Barium	403	mg/kg	MS MSD	73 69	%	J	Low	Datum is estimated, possible low bias; MS/MSD recoveries outside acceptance criteria
PSS	PSS-120406-1800	04/12/06	SW-846 6010B	Nickel	49.7	mg/kg	SLD	10.2	%	J	None	Datum is estimated, bias unknown; serial dilution %D outside acceptance criterion
PSS	PSS-120406-1800	04/12/06	SW-846 6010B	Selenium	2.5	mg/kg	SLD	54.6	%	J	None	Datum is estimated, bias unknown; serial dilution %D outside acceptance criterion
PSS	PSS-120406-1800	04/12/06	SW-846 6010B	Silver	4.7	mg/kg	SLD	10.8	%	J	None	Datum is estimated, bias unknown; serial dilution %D outside acceptance criterion
PSS	PSS-120406-1800	04/12/06	SW-846 6010B	Zinc	421	mg/kg	SLD LB	11.7 0.50 T	% mg/kg	JB	None	Datum is estimated, bias unknown; serial dilution percent difference outside acceptance criterion Analyte detected in associated blank; sample concentration greater than five times the blank concentration
RS	RS-120406-1815	04/12/06	SW-846 6010B	Zinc	418	mg/kg	LB	0.50 T	mg/kg	B	None	Analyte detected in associated blank; sample concentration greater than five times the blank concentration
RS	RS-120406-1815	04/12/06	SW-846 8082	2,2',3,4',5,5',6-Heptachlorobiphenyl	12 D	µg/kg	CVS	16.8	%	J	None	Datum is estimated, bias unknown; CVS %D outside acceptance criterion
RS	RS-120406-1815	04/12/06	SW-846 8082	2,2',3,4,4',5,5'-Heptachlorobiphenyl	10 D	µg/kg	CONF	48.4	%	J	None	Datum is estimated, bias unknown; %D between primary and secondary GC columns outside acceptance criterion
RS	RS-120406-1815	04/12/06	SW-846 8082	2,2',3,4,5'-Pentachlorobiphenyl	9 D	µg/kg	CONF	1000	%	J	None	Datum is estimated, bias unknown; %D between primary and secondary GC columns outside acceptance criterion
RS	RS-120406-1815	04/12/06	SW-846 8082	2,2',5,5'-Tetrachlorobiphenyl	33 D	µg/kg	CONF	150	%	J	None	Datum is estimated, bias unknown; %D between primary and secondary GC columns outside acceptance criterion
RS	RS-120406-1815	04/12/06	SW-846 8082	2,3-Dichlorobiphenyl	3.1 TD	µg/kg	CONF	117	%	J	None	Datum is estimated, bias unknown; %D between primary and secondary GC columns outside acceptance criterion

TABLE 1
DATA QUALIFIERS SUMMARY TABLE
DEMONSTRATION TESTING AND FULL-SCALE OPERATION OF THE BIOGENESIS SEDIMENT DECONTAMINATION PROCESS, KEASBEY, NEW JERSEY
(Page 146 of 188)

Location Identification	Sample Identification	Sample Date	Analysis	Analyte	Sample Result	Sample Units	QC Type	QC Result	QC Units	Qualifier	Bias	Comment
RS	RS-120406-1815	04/12/06	SW-846 8082	2,4,5-Trichlorobiphenyl	40 D	µg/kg	CVS	-18.7	%	J	None	Datum is estimated, bias unknown; CVS %D outside acceptance criterion
RS	RS-120406-1815	04/12/06	SW-846 8082	2-Chlorobiphenyl	41 TD	µg/kg	CONF	150	%	J	None	Datum is estimated, bias unknown; %D between primary and secondary GC columns outside acceptance criterion
RS	RS-120406-1815	04/12/06	SW-846 8270C	Pentachlorophenol	<56000 D	µg/kg	LCS	0	%	UJ	Low	Possible false negative; LCS recovery outside acceptance criteria
RS	RS-120406-1815	04/12/06	SW-846 8290	1,2,3,4,6,7,8-Heptachlorodibenzo-p-dioxin	530	pg/g	LB	0.11 T	pg/g	B	None	Analyte detected in associated blank; sample concentration greater than five times the blank concentration
RS	RS-120406-1815	04/12/06	SW-846 8290	1,2,3,4,6,7,8-Heptachlorodibenzofuran	370	pg/g	PDE LB	N/A 0.071 T	N/A pg/g	JB	None	Datum is estimated, bias unknown; interfering polychlorinated diphenyl ether peak present Analyte detected in associated blank; sample concentration greater than five times the blank concentration
RS	RS-120406-1815	04/12/06	SW-846 8290	1,2,3,4,7,8,9-Heptachlorodibenzofuran	39	pg/g	PDE	N/A	N/A	J	None	Datum is estimated, bias unknown; interfering polychlorinated diphenyl ether peak present
RS	RS-120406-1815	04/12/06	SW-846 8290	1,2,3,4,7,8-Hexachlorodibenzofuran	66	pg/g	PDE	N/A	N/A	J	None	Datum is estimated, bias unknown; interfering polychlorinated diphenyl ether peak present
RS	RS-120406-1815	04/12/06	SW-846 8290	1,2,3,6,7,8-Hexachlorodibenzofuran	30	pg/g	LB	0.050 T	pg/g	B	None	Analyte detected in associated blank; sample concentration greater than five times the blank concentration
RS	RS-120406-1815	04/12/06	SW-846 8290	1,2,3,7,8,9-Hexachlorodibenzofuran	2.3 T	pg/g	IAR	2.29	N/A	J	None	Datum is estimated, bias unknown; ion abundance ratio outside acceptance criteria
RS	RS-120406-1815	04/12/06	SW-846 8290	1,2,3,7,8-Pentachlorodibenzofuran	20	pg/g	PDE	N/A	N/A	J	None	Datum is estimated, bias unknown; interfering polychlorinated diphenyl ether peak present
RS	RS-120406-1815	04/12/06	SW-846 8290	Octachlorodibenzo-p-dioxin	6500	pg/g	LB	0.70 T	pg/g	B	None	Analyte detected in associated blank; sample concentration greater than five times the blank concentration
RS	RS-120406-1815	04/12/06	SW-846 8290	Octachlorodibenzofuran	580	pg/g	LB	0.20 T	pg/g	B	None	Analyte detected in associated blank; sample concentration greater than five times the blank concentration
RS	RS-120406-1815	04/12/06	SW-846 8081A	beta Endosulfan	55	µg/kg	CONF	67	%	J	None	Datum is estimated, bias unknown; %D between primary and secondary GC columns outside acceptance criterion
RS	RS-120406-1815	04/12/06	SW-846 8081A	p,p'-DDD	200	µg/kg	CONF	525	%	J	None	Datum is estimated, bias unknown; %D between primary and secondary GC columns outside acceptance criterion
SS1	SS1-120406-1805	04/12/06	SW-846 6010B	Zinc	246	mg/kg	LB	0.50 T	mg/kg	B	None	Analyte detected in associated blank; sample concentration greater than five times the blank concentration
SS2	SS2-120406-1810	04/12/06	SW-846 6010B	Zinc	326	mg/kg	LB	0.50 T	mg/kg	B	None	Analyte detected in associated blank; sample concentration greater than five times the blank concentration

TABLE 1
DATA QUALIFIERS SUMMARY TABLE
DEMONSTRATION TESTING AND FULL-SCALE OPERATION OF THE BIOGENESIS SEDIMENT DECONTAMINATION PROCESS, KEASBEY, NEW JERSEY
(Page 147 of 188)

Location Identification	Sample Identification	Sample Date	Analysis	Analyte	Sample Result	Sample Units	QC Type	QC Result	QC Units	Qualifier	Bias	Comment
TS	TS-120406-1835	04/12/06	SW-846 6010B	Zinc	237	mg/kg	LB	0.50 T	mg/kg	B	None	Analyte detected in associated blank; sample concentration greater than five times the blank concentration
TS	TS-120406-1835	04/12/06	SW-846 8082	2,2',3,4',5,5',6-Heptachlorobiphenyl	7.5 D	µg/kg	CVS	16.8	%	J	None	Datum is estimated, bias unknown; CVS %D outside acceptance criterion
TS	TS-120406-1835	04/12/06	SW-846 8082	2,2',3,4,4',5,5'-Heptachlorobiphenyl	6.7 D	µg/kg	CONF	46.1	%	J	None	Datum is estimated, bias unknown; %D between primary and secondary GC columns outside acceptance criterion
TS	TS-120406-1835	04/12/06	SW-846 8082	2,2',3,4,5'-Pentachlorobiphenyl	6.4 D	µg/kg	CONF	1000	%	J	None	Datum is estimated, bias unknown; %D between primary and secondary GC columns outside acceptance criterion
TS	TS-120406-1835	04/12/06	SW-846 8082	2,2',5,5'-Tetrachlorobiphenyl	23 D	µg/kg	CONF	174	%	J	None	Datum is estimated, bias unknown; %D between primary and secondary GC columns outside acceptance criterion
TS	TS-120406-1835	04/12/06	SW-846 8082	2,4,5-Trichlorobiphenyl	30 D	µg/kg	CVS	-18.7	%	J	None	Datum is estimated, bias unknown; CVS %D outside acceptance criterion
TS	TS-120406-1835	04/12/06	SW-846 8082	2-Chlorobiphenyl	15 TD	µg/kg	CONF	370	%	J	None	Datum is estimated, bias unknown; %D between primary and secondary GC columns outside acceptance criterion
TS	TS-120406-1835	04/12/06	SW-846 8270C	Pentachlorophenol	<12000 D	µg/kg	LCS	0	%	UJ	Low	Possible false negative; LCS recovery outside acceptance criteria
TS	TS-120406-1835	04/12/06	SW-846 8290	1,2,3,4,6,7,8-Heptachlorodibenzo-p-dioxin	68	pg/g	LB	0.11 T	pg/g	B	None	Analyte detected in associated blank; sample concentration greater than five times the blank concentration
TS	TS-120406-1835	04/12/06	SW-846 8290	1,2,3,4,6,7,8-Heptachlorodibenzofuran	35	pg/g	LB	0.071 T	pg/g	B	None	Analyte detected in associated blank; sample concentration greater than five times the blank concentration
TS	TS-120406-1835	04/12/06	SW-846 8290	1,2,3,4,7,8,9-Heptachlorodibenzofuran	3.6 T	pg/g	PDE	N/A	N/A	J	None	Datum is estimated, bias unknown; interfering polychlorinated diphenyl ether peak present
TS	TS-120406-1835	04/12/06	SW-846 8290	1,2,3,4,7,8-Hexachlorodibenzo-p-dioxin	0.71 T	pg/g	IAR	1.01	N/A	J	None	Datum is estimated, bias unknown; ion abundance ratio outside acceptance criteria
TS	TS-120406-1835	04/12/06	SW-846 8290	1,2,3,6,7,8-Hexachlorodibenzofuran	3.2 T	pg/g	LB	0.050 T	pg/g	B	None	Analyte detected in associated blank; sample concentration greater than five times the blank concentration
TS	TS-120406-1835	04/12/06	SW-846 8290	1,2,3,7,8-Pentachlorodibenzo-p-dioxin	1.1 T	pg/g	IAR	1.07	N/A	J	None	Datum is estimated, bias unknown; ion abundance ratio outside acceptance criteria
TS	TS-120406-1835	04/12/06	SW-846 8290	Octachlorodibenzo-p-dioxin	790	pg/g	LB	0.70 T	pg/g	B	None	Analyte detected in associated blank; sample concentration greater than five times the blank concentration
TS	TS-120406-1835	04/12/06	SW-846 8290	Octachlorodibenzofuran	56	pg/g	LB	0.20 T	pg/g	B	None	Analyte detected in associated blank; sample concentration greater than five times the blank concentration

TABLE 1
DATA QUALIFIERS SUMMARY TABLE
DEMONSTRATION TESTING AND FULL-SCALE OPERATION OF THE BIOGENESIS SEDIMENT DECONTAMINATION PROCESS, KEASBEY, NEW JERSEY
(Page 148 of 188)

Location Identification	Sample Identification	Sample Date	Analysis	Analyte	Sample Result	Sample Units	QC Type	QC Result	QC Units	Qualifier	Bias	Comment
TS	TS-120406-1835	04/12/06	SW-846 8081A	beta Endosulfan	26	µg/kg	CONF	100	%	J	None	Datum is estimated, bias unknown; %D between primary and secondary GC columns outside acceptance criterion
TS1	TS1-120406-1820	04/12/06	SW-846 6010B	Zinc	228	mg/kg	LB	0.50 T	mg/kg	B	None	Analyte detected in associated blank; sample concentration greater than five times the blank concentration
TS2	TS2-120406-1825	04/12/06	SW-846 6010B	Zinc	168	mg/kg	LB	0.50 T	mg/kg	B	None	Analyte detected in associated blank; sample concentration greater than five times the blank concentration
TS3	TS3-120406-1830	04/12/06	SW-846 6010B	Zinc	248	mg/kg	LB	0.50 T	mg/kg	B	None	Analyte detected in associated blank; sample concentration greater than five times the blank concentration
WS	WS-120406-1840	04/12/06	SW-846 8270 SIM	Benzo(b)fluoranthene	750 D	µg/kg	MSD	33	%	J	Low	Datum is estimated, possible low bias; MSD recovery outside acceptance criteria
WS	WS-120406-1840	04/12/06	SW-846 8270 SIM	Fluoranthene	1700 D	µg/kg	MS	38	%	J	Low	Datum is estimated, possible low bias; MS recovery outside acceptance criteria
WS	WS-120406-1840	04/12/06	SW-846 8270 SIM	Fluorene	160 TD	µg/kg	MS MSD	35 36	%	J	Low	Datum is estimated, possible low bias; MS/MSD recoveries outside acceptance criteria
WS	WS-120406-1840	04/12/06	SW-846 8270 SIM	Indeno(1,2,3-c,d)pyrene	290 D	µg/kg	MSD	39	%	J	Low	Datum is estimated, possible low bias; MSD recovery outside acceptance criteria
WS	WS-120406-1840	04/12/06	SW-846 8270 SIM	Pyrene	1600 D	µg/kg	MS MSD	26 20	%	J	Low	Datum is estimated, possible low bias; MS/MSD recoveries outside acceptance criteria
WS	WS-120406-1840	04/12/06	SW-846 6010B	Zinc	770	mg/kg	LB	0.50 T	mg/kg	B	None	Analyte detected in associated blank; sample concentration greater than five times the blank concentration
WS	WS-120406-1840	04/12/06	SW-846 8082	2,2',3,4',5,5',6-Heptachlorobiphenyl	24 D	µg/kg	CVS	16.8	%	J	None	Datum is estimated, bias unknown; CVS %D outside acceptance criterion
WS	WS-120406-1840	04/12/06	SW-846 8082	2,2',3,4,4',5,5'-Heptachlorobiphenyl	23 D	µg/kg	CONF	45.1	%	J	None	Datum is estimated, bias unknown; %D between primary and secondary GC columns outside acceptance criterion
WS	WS-120406-1840	04/12/06	SW-846 8082	2,2',3,4,5'-Pentachlorobiphenyl	21 D	µg/kg	CONF	1000	%	J	None	Datum is estimated, bias unknown; %D between primary and secondary GC columns outside acceptance criterion
WS	WS-120406-1840	04/12/06	SW-846 8082	2,2',5,5'-Tetrachlorobiphenyl	76 D	µg/kg	CONF	153	%	J	None	Datum is estimated, bias unknown; %D between primary and secondary GC columns outside acceptance criterion
WS	WS-120406-1840	04/12/06	SW-846 8082	2,3-Dichlorobiphenyl	5.2 D	µg/kg	CONF	171	%	J	None	Datum is estimated, bias unknown; %D between primary and secondary GC columns outside acceptance criterion
WS	WS-120406-1840	04/12/06	SW-846 8082	2,4,5-Trichlorobiphenyl	98 D	µg/kg	CVS	-18.7	%	J	None	Datum is estimated, bias unknown; CVS %D outside acceptance criterion
WS	WS-120406-1840	04/12/06	SW-846 8270C	Acenaphthylene	230 TD	µg/kg	MS	44	%	J	Low	Datum is estimated, possible low bias; MS recovery outside acceptance criteria

TABLE 1
DATA QUALIFIERS SUMMARY TABLE
DEMONSTRATION TESTING AND FULL-SCALE OPERATION OF THE BIOGENESIS SEDIMENT DECONTAMINATION PROCESS, KEASBEY, NEW JERSEY
(Page 149 of 188)

Location Identification	Sample Identification	Sample Date	Analysis	Analyte	Sample Result	Sample Units	QC Type	QC Result	QC Units	Qualifier	Bias	Comment
WS	WS-120406-1840	04/12/06	SW-846 8270C	Anthracene	490 TD	µg/kg	MS MSD	46 45	%	J	Low	Datum is estimated, possible low bias; MS/MSD recoveries outside acceptance criteria
WS	WS-120406-1840	04/12/06	SW-846 8270C	Benzo(a)anthracene	780 TD	µg/kg	MS MSD	49 45	%	J	Low	Datum is estimated, possible low bias; MS/MSD recoveries outside acceptance criteria
WS	WS-120406-1840	04/12/06	SW-846 8270C	Benzo(a)pyrene	490 TD	µg/kg	MS MSD	42 37	%	J	Low	Datum is estimated, possible low bias; MS/MSD recoveries outside acceptance criteria
WS	WS-120406-1840	04/12/06	SW-846 8270C	Benzo(b)fluoranthene	530 TD	µg/kg	MS MSD	30 22	%	J	Low	Datum is estimated, possible low bias; MS/MSD recoveries outside acceptance criteria
WS	WS-120406-1840	04/12/06	SW-846 8270C	Benzo(k)fluoranthene	<5800 D	µg/kg	MS MSD	43 44	%	UJ	Low	Possible false negative; MS/MSD recoveries outside acceptance criteria
WS	WS-120406-1840	04/12/06	SW-846 8270C	Dibenz(a,h)anthracene	<5800 D	µg/kg	MS MSD	41 38	%	UJ	Low	Possible false negative; MS/MSD recoveries outside acceptance criteria
WS	WS-120406-1840	04/12/06	SW-846 8270C	Fluoranthene	1800 TD	µg/kg	MS MSD	50 33	%	J	Low	Datum is estimated, possible low bias; MS/MSD recoveries outside acceptance criteria
WS	WS-120406-1840	04/12/06	SW-846 8270C	Fluorene	<5800 D	µg/kg	MS MSD	39 38	%	UJ	Low	Possible false negative; MS/MSD recoveries outside acceptance criteria
WS	WS-120406-1840	04/12/06	SW-846 8270C	Hexachlorobenzene	<5800 D	µg/kg	MS MSD	44 39	%	UJ	Low	Possible false negative; MS/MSD recoveries outside acceptance criteria
WS	WS-120406-1840	04/12/06	SW-846 8270C	Hexachlorobutadiene	<5800 D	µg/kg	MSD	36	%	UJ	Low	Possible false negative; MSD recovery outside acceptance criteria
WS	WS-120406-1840	04/12/06	SW-846 8270C	Hexachloroethane	<5800 D	µg/kg	MS	23	%	UJ	Low	Possible false negative; MS recovery outside acceptance criteria
WS	WS-120406-1840	04/12/06	SW-846 8270C	Indeno(1,2,3-c,d)pyrene	<5800 D	µg/kg	MS MSD	45 46	%	UJ	Low	Possible false negative; MS/MSD recoveries outside acceptance criteria
WS	WS-120406-1840	04/12/06	SW-846 8270C	Naphthalene	260 TD	µg/kg	MS	39	%	J	Low	Datum is estimated, possible low bias; MS recovery outside acceptance criteria
WS	WS-120406-1840	04/12/06	SW-846 8270C	Pentachlorophenol	<28000 D	µg/kg	LCS MS	0 0	%	UJ	Low	Possible false negative; LCS and MS recoveries outside acceptance criteria
WS	WS-120406-1840	04/12/06	SW-846 8290	1,2,3,4,6,7,8-Heptachlorodibenzo-p-dioxin	120	pg/g	LB	0 11 T	pg/g	B	None	Analyte detected in associated blank; sample concentration greater than five times the blank concentration
WS	WS-120406-1840	04/12/06	SW-846 8290	1,2,3,4,6,7,8-Heptachlorodibenzofuran	77	pg/g	LB	0 071 T	pg/g	B	None	Analyte detected in associated blank; sample concentration greater than five times the blank concentration
WS	WS-120406-1840	04/12/06	SW-846 8290	1,2,3,4,7,8,9-Heptachlorodibenzofuran	6 9 T	pg/g	PDE	N/A	N/A	J	None	Datum is estimated, bias unknown; interfering polychlorinated diphenyl ether peak present
WS	WS-120406-1840	04/12/06	SW-846 8290	1,2,3,4,7,8-Hexachlorodibenzo-p-dioxin	1 5 T	pg/g	IAR	1	N/A	J	None	Datum is estimated, bias unknown; ion abundance ratio outside acceptance criteria
WS	WS-120406-1840	04/12/06	SW-846 8290	1,2,3,6,7,8-Hexachlorodibenzo-p-Dioxin	6 4 T	pg/g	IAR	1 49	N/A	J	None	Datum is estimated, bias unknown; ion abundance ratio outside acceptance criteria

TABLE 1
DATA QUALIFIERS SUMMARY TABLE
DEMONSTRATION TESTING AND FULL-SCALE OPERATION OF THE BIOGENESIS SEDIMENT DECONTAMINATION PROCESS, KEASBEY, NEW JERSEY
(Page150 of 188)

Location Identification	Sample Identification	Sample Date	Analysis	Analyte	Sample Result	Sample Units	QC Type	QC Result	QC Units	Qualifier	Bias	Comment
WS	WS-120406-1840	04/12/06	SW-846 8290	1,2,3,6,7,8-Hexachlorodibenzofuran	6.0 T	pg/g	LB	0.050 T	pg/g	B	None	Analyte detected in associated blank; sample concentration greater than five times the blank concentration
WS	WS-120406-1840	04/12/06	SW-846 8290	1,2,3,7,8-Pentachlorodibenzo-p-dioxin	1.3 T	pg/g	IAR	0.8	N/A	J	None	Datum is estimated, bias unknown; ion abundance ratio outside acceptance criteria
WS	WS-120406-1840	04/12/06	SW-846 8290	1,2,3,7,8-Pentachlorodibenzofuran	3.5 T	pg/g	IAR	1.8	N/A	J	None	Datum is estimated, bias unknown; ion abundance ratio outside acceptance criteria
WS	WS-120406-1840	04/12/06	SW-846 8290	2,3,7,8-Tetrachlorodibenzofuran	3.4 T	pg/g	IAR CMC	0.28 3	N/A s	J	None	Datum is estimated, bias unknown; ion abundance ratio and comax peaks outside acceptance criteria
WS	WS-120406-1840	04/12/06	SW-846 8290	Octachlorodibenzo-p-dioxin	1400	pg/g	LB	0.70 T	pg/g	B	None	Analyte detected in associated blank; sample concentration greater than five times the blank concentration
WS	WS-120406-1840	04/12/06	SW-846 8290	Octachlorodibenzofuran	120	pg/g	LB	0.20 T	pg/g	B	None	Analyte detected in associated blank; sample concentration greater than five times the blank concentration
WS	WS-120406-1840	04/12/06	SW-846 8081A	p,p'-DDD	280	µg/kg	CONF	667	%	J	None	Datum is estimated, bias unknown; %D between primary and secondary GC columns outside acceptance criterion
WS	WS-120406-1840	04/12/06	SW-846 8081A	p,p'-DDT	180	µg/kg	CONF	68	%	J	None	Datum is estimated, bias unknown; %D between primary and secondary GC columns outside acceptance criterion
PSS	PSS-130406-1700	04/13/06	SW-846 6010B	Selenium	2.4	mg/kg	SLD	100	%	J	None	Datum is estimated, bias unknown; serial dilution %D outside acceptance criterion
TS1	TS1-130406-1720	04/13/06	SW-846 8270 SIM	Benzo(a)anthracene	4100 D	µg/kg	MS MSD	126 166	%	J	High	Datum is estimated, possible high bias; MS/MSD recoveries outside acceptance criteria
TS1	TS1-130406-1720	04/13/06	SW-846 8270 SIM	Benzo(a)pyrene	4000 D	µg/kg	MSD	126	%	J	High	Datum is estimated, possible high bias; MSD recovery outside acceptance criteria
TS1	TS1-130406-1720	04/13/06	SW-846 8270 SIM	Benzo(b)fluoranthene	4400 D	µg/kg	MSD	117	%	J	High	Datum is estimated, possible high bias; MSD recovery outside acceptance criteria
TS1	TS1-130406-1720	04/13/06	SW-846 8270 SIM	Benzo(k)fluoranthene	1600 D	µg/kg	MS	133	%	J	High	Datum is estimated, possible high bias; MS recovery outside acceptance criteria
TS1	TS1-130406-1720	04/13/06	SW-846 8270 SIM	Chrysene	4400 D	µg/kg	MSD	125	%	J	High	Datum is estimated, possible high bias; MSD recovery outside acceptance criteria
TS1	TS1-130406-1720	04/13/06	SW-846 8270 SIM	Phenanthrene	5100 D	µg/kg	MS MSD	147 157	%	J	High	Datum is estimated, possible high bias; MS/MSD recoveries outside acceptance criteria
PSS	PSS-170406-1700	04/17/06	Lloyd Kahn	Total organic carbon	41700	mg/kg	MS	142	%	J	High	Datum is estimated, possible high bias; MS recovery outside acceptance criteria
PSS	PSS-170406-1700	04/17/06	SW-846 6010B	Selenium	2.2	mg/kg	SLD	100	%	J	None	Datum is estimated, bias unknown; serial dilution %D outside acceptance criterion

TABLE 1
DATA QUALIFIERS SUMMARY TABLE
DEMONSTRATION TESTING AND FULL-SCALE OPERATION OF THE BIOGENESIS SEDIMENT DECONTAMINATION PROCESS, KEASBEY, NEW JERSEY
(Page151 of 188)

Location Identification	Sample Identification	Sample Date	Analysis	Analyte	Sample Result	Sample Units	QC Type	QC Result	QC Units	Qualifier	Bias	Comment
RS	RS-170406-1725	04/17/06	SW-846 8082	2,2',3,4,4',5,5'-Heptachlorobiphenyl	12 D	µg/kg	CONF	48 6	%	J	None	Datum is estimated, bias unknown; %D between primary and secondary GC columns outside acceptance criterion
RS	RS-170406-1725	04/17/06	SW-846 8082	2,2',3,4,5'-Pentachlorobiphenyl	10 D	µg/kg	CONF	1000	%	J	None	Datum is estimated, bias unknown; %D between primary and secondary GC columns outside acceptance criterion
RS	RS-170406-1725	04/17/06	SW-846 8082	2,2',5,5'-Tetrachlorobiphenyl	40 D	µg/kg	CONF	89	%	J	None	Datum is estimated, bias unknown; %D between primary and secondary GC columns outside acceptance criterion
RS	RS-170406-1725	04/17/06	SW-846 8082	2,3-Dichlorobiphenyl	3 5 TD	µg/kg	CONF LB	109 0 054 T	% µg/kg	JB	None	Datum is estimated, bias unknown; %D between primary and secondary GC columns outside acceptance criterion Analyte detected in associated blank; sample concentration greater than five times the blank concentration
RS	RS-170406-1725	04/17/06	SW-846 8082	2-Chlorobiphenyl	85 D	µg/kg	CONF LB	124 0 22 T	% µg/kg	JB	None	Datum is estimated, bias unknown; %D between primary and secondary GC columns outside acceptance criterion Analyte detected in associated blank; sample concentration greater than five times the blank concentration
RS	RS-170406-1725	04/17/06	SW-846 8290	1,2,3,4,7,8,9-Heptachlorodibenzofuran	28	pg/g	PDE	N/A	N/A	J	None	Datum is estimated, bias unknown; interfering polychlorinated diphenyl ether peak present
RS	RS-170406-1725	04/17/06	SW-846 8290	1,2,3,4,7,8-Hexachlorodibenzofuran	75	pg/g	PDE	N/A	N/A	J	None	Datum is estimated, bias unknown; interfering polychlorinated diphenyl ether peak present
RS	RS-170406-1725	04/17/06	SW-846 8290	1,2,3,6,7,8-Hexachlorodibenzofuran	29	pg/g	IAR	1	N/A	J	None	Datum is estimated, bias unknown; ion abundance ratio outside acceptance criteria
RS	RS-170406-1725	04/17/06	SW-846 8290	1,2,3,7,8,9-Hexachlorodibenzofuran	3 6 T	pg/g	LB	0 12 T	pg/g	B	None	Analyte detected in associated blank; sample concentration greater than five times the blank concentration
RS	RS-170406-1725	04/17/06	SW-846 8290	1,2,3,7,8-Pentachlorodibenzo-p-dioxin	1 4 T	pg/g	IAR	0 26	N/A	J	None	Datum is estimated, bias unknown; ion abundance ratio outside acceptance criteria
RS	RS-170406-1725	04/17/06	SW-846 8290	1,2,3,7,8-Pentachlorodibenzofuran	12 T	pg/g	IAR	1 83	N/A	J	None	Datum is estimated, bias unknown; ion abundance ratio outside acceptance criteria
RS	RS-170406-1725	04/17/06	SW-846 8290	2,3,7,8-Tetrachlorodibenzo-p-dioxin	37	pg/g	IAR	0 9	N/A	J	None	Datum is estimated, bias unknown; ion abundance ratio outside acceptance criteria
RS	RS-170406-1725	04/17/06	SW-846 8290	Octachlorodibenzo-p-dioxin	6500	pg/g	LB	0 93 T	pg/g	B	None	Analyte detected in associated blank; sample concentration greater than five times the blank concentration
RS	RS-170406-1725	04/17/06	SW-846 8290	Octachlorodibenzofuran	910	pg/g	LB	0 21 T	pg/g	B	None	Analyte detected in associated blank; sample concentration greater than five times the blank concentration
RS	RS-170406-1725	04/17/06	SW-846 8081A	beta Endosulfan	61	µg/kg	CONF	77 9	%	J	None	Datum is estimated, bias unknown; %D between primary and secondary GC columns outside acceptance criterion
RS	RS-170406-1725	04/17/06	SW-846 8081A	Endrin	52	µg/kg	CONF	41 6	%	J	None	Datum is estimated, bias unknown; %D between primary and secondary GC columns outside acceptance criterion

TABLE 1
DATA QUALIFIERS SUMMARY TABLE
DEMONSTRATION TESTING AND FULL-SCALE OPERATION OF THE BIOGENESIS SEDIMENT DECONTAMINATION PROCESS, KEASBEY, NEW JERSEY
(Page152 of 188)

Location Identification	Sample Identification	Sample Date	Analysis	Analyte	Sample Result	Sample Units	QC Type	QC Result	QC Units	Qualifier	Bias	Comment
RS	RS-170406-1725	04/17/06	SW-846 8081A	p,p'-DDD	280	µg/kg	CONF	212	%	J	None	Datum is estimated, bias unknown; %D between primary and secondary GC columns outside acceptance criterion
TS	TS-170406-1745	04/17/06	SW-846 8082	2,2',3,4,4',5,5'-Heptachlorobiphenyl	6 2 D	µg/kg	CONF	52 2	%	J	None	Datum is estimated, bias unknown; %D between primary and secondary GC columns outside acceptance criterion
TS	TS-170406-1745	04/17/06	SW-846 8082	2,2',3,4,5'-Pentachlorobiphenyl	5 5 D	µg/kg	CONF	1000	%	J	None	Datum is estimated, bias unknown; %D between primary and secondary GC columns outside acceptance criterion
TS	TS-170406-1745	04/17/06	SW-846 8082	2,2',3,4,5,5'-Hexachlorobiphenyl	2 6 D	µg/kg	CONF	45	%	J	None	Datum is estimated, bias unknown; %D between primary and secondary GC columns outside acceptance criterion
TS	TS-170406-1745	04/17/06	SW-846 8082	2,2',5,5'-Tetrachlorobiphenyl	20 D	µg/kg	CONF	102	%	J	None	Datum is estimated, bias unknown; %D between primary and secondary GC columns outside acceptance criterion
TS	TS-170406-1745	04/17/06	SW-846 8082	2-Chlorobiphenyl	19 TD	µg/kg	CONF LB	216 0 22 T	% µg/kg	JB	None	Datum is estimated, bias unknown; %D between primary and secondary GC columns outside acceptance criterion Analyte detected in associated blank; sample concentration greater than five times the blank concentration
TS	TS-170406-1745	04/17/06	SW-846 8270C	2,4,5-Trichlorophenol	<4700 D	µg/kg	MSD	41	%	UJ	Low	Possible false negative; MSD recovery outside acceptance criteria
TS	TS-170406-1745	04/17/06	SW-846 8270C	2,4,6-Trichlorophenol	<4700 D	µg/kg	MSD	46	%	UJ	Low	Possible false negative; MSD recovery outside acceptance criteria
TS	TS-170406-1745	04/17/06	SW-846 8270C	Anthracene	480 TD	µg/kg	MSD	49	%	J	Low	Datum is estimated, possible low bias; MSD recovery outside acceptance criteria
TS	TS-170406-1745	04/17/06	SW-846 8270C	Benzo(a)anthracene	1100 TD	µg/kg	MSD	45	%	J	Low	Datum is estimated, possible low bias; MSD recovery outside acceptance criteria
TS	TS-170406-1745	04/17/06	SW-846 8270C	Benzo(a)pyrene	1100 TD	µg/kg	MSD	34	%	J	Low	Datum is estimated, possible low bias; MSD recovery outside acceptance criteria
TS	TS-170406-1745	04/17/06	SW-846 8270C	Benzo(b)fluoranthene	1300 TD	µg/kg	MSD	29	%	J	Low	Datum is estimated, possible low bias; MSD recovery outside acceptance criteria
TS	TS-170406-1745	04/17/06	SW-846 8270C	Benzo(g,h,i)perylene	790 TD	µg/kg	MSD	40	%	J	Low	Datum is estimated, possible low bias; MSD recovery outside acceptance criteria
TS	TS-170406-1745	04/17/06	SW-846 8270C	Benzo(k)fluoranthene	530 TD	µg/kg	MSD	36	%	J	Low	Datum is estimated, possible low bias; MSD recovery outside acceptance criteria
TS	TS-170406-1745	04/17/06	SW-846 8270C	Chrysene	1200 TD	µg/kg	MSD	30	%	J	Low	Datum is estimated, possible low bias; MSD recovery outside acceptance criteria
TS	TS-170406-1745	04/17/06	SW-846 8270C	Fluoranthene	2100 TD	µg/kg	MS MSD	47 31	%	J	Low	Datum is estimated, possible low bias; MS/MSD recoveries outside acceptance criteria
TS	TS-170406-1745	04/17/06	SW-846 8270C	Fluorene	200 TD	µg/kg	MSD	46	%	J	Low	Datum is estimated, possible low bias; MSD recovery outside acceptance criteria

TABLE 1
DATA QUALIFIERS SUMMARY TABLE
DEMONSTRATION TESTING AND FULL-SCALE OPERATION OF THE BIOGENESIS SEDIMENT DECONTAMINATION PROCESS, KEASBEY, NEW JERSEY
(Page153 of 188)

Location Identification	Sample Identification	Sample Date	Analysis	Analyte	Sample Result	Sample Units	QC Type	QC Result	QC Units	Qualifier	Bias	Comment
TS	TS-170406-1745	04/17/06	SW-846 8270C	Hexachloroethane	<4700 D	µg/kg	MS MSD	37 32	%	UJ	Low	Possible false negative; MS/MSD recoveries outside acceptance criteria
TS	TS-170406-1745	04/17/06	SW-846 8270C	Indeno(1,2,3-c,d)pyrene	650 TD	µg/kg	MSD	41	%	J	Low	Datum is estimated, possible low bias; MSD recovery outside acceptance criteria
TS	TS-170406-1745	04/17/06	SW-846 8270C	Pyrene	2200 TD	µg/kg	MSD	27	%	J	Low	Datum is estimated, possible low bias; MSD recovery outside acceptance criteria
TS	TS-170406-1745	04/17/06	SW-846 8290	1,2,3,4,7,8,9-Heptachlorodibenzofuran	2.9 T	pg/g	PDE	N/A	N/A	J	None	Datum is estimated, bias unknown; interfering polychlorinated diphenyl ether peak present
TS	TS-170406-1745	04/17/06	SW-846 8290	1,2,3,4,7,8-Hexachlorodibenzo-p-dioxin	0.60 T	pg/g	IAR	1.52	N/A	J	None	Datum is estimated, bias unknown; ion abundance ratio outside acceptance criteria
TS	TS-170406-1745	04/17/06	SW-846 8290	1,2,3,4,7,8-Hexachlorodibenzofuran	10	pg/g	PDE	N/A	N/A	J	None	Datum is estimated, bias unknown; interfering polychlorinated diphenyl ether peak present
TS	TS-170406-1745	04/17/06	SW-846 8290	2,3,4,6,7,8-Hexachlorodibenzofuran	2.2 T	pg/g	PDE	N/A	N/A	J	None	Datum is estimated, bias unknown; interfering polychlorinated diphenyl ether peak present
TS	TS-170406-1745	04/17/06	SW-846 8290	2,3,7,8-Tetrachlorodibenzofuran	3.9	pg/g	IAR	0.93	N/A	J	None	Datum is estimated, bias unknown; ion abundance ratio outside acceptance criteria
TS	TS-170406-1745	04/17/06	SW-846 8290	Octachlorodibenzo-p-dioxin	680	pg/g	LB	0.93 T	pg/g	B	None	Analyte detected in associated blank; sample concentration greater than five times the blank concentration
TS	TS-170406-1745	04/17/06	SW-846 8290	Octachlorodibenzofuran	53	pg/g	LB	0.21 T	pg/g	B	None	Analyte detected in associated blank; sample concentration greater than five times the blank concentration
TS	TS-170406-1745	04/17/06	SW-846 8081A	Dieldrin	18	µg/kg	CONF	947	%	J	None	Datum is estimated, bias unknown; %D between primary and secondary GC columns outside acceptance criterion
TS	TS-170406-1745	04/17/06	SW-846 8081A	p,p'-DDD	250	µg/kg	CONF	112	%	J	None	Datum is estimated, bias unknown; %D between primary and secondary GC columns outside acceptance criterion
WS	WS-170406-1745	04/17/06	SW-846 8082	2,2',3,4,5'-Pentachlorobiphenyl	25 D	µg/kg	CONF	1000	%	J	None	Datum is estimated, bias unknown; %D between primary and secondary GC columns outside acceptance criterion
WS	WS-170406-1745	04/17/06	SW-846 8082	2,2',5,5'-Tetrachlorobiphenyl	89 D	µg/kg	CONF	91.2	%	J	None	Datum is estimated, bias unknown; %D between primary and secondary GC columns outside acceptance criterion
WS	WS-170406-1745	04/17/06	SW-846 8082	2,3-Dichlorobiphenyl	15 D	µg/kg	LB	0.054 T	µg/kg	B	None	Analyte detected in associated blank; sample concentration greater than five times the blank concentration
WS	WS-170406-1745	04/17/06	SW-846 8082	2-Chlorobiphenyl	100 D	µg/kg	CONF LB	73.3 0.22 T	% µg/kg	JB	None	Datum is estimated, bias unknown; %D between primary and secondary GC columns outside acceptance criterion Analyte detected in associated blank; sample concentration greater than five times the blank concentration
WS	WS-170406-1745	04/17/06	SW-846 8290	1,2,3,4,7,8-Hexachlorodibenzo-p-dioxin	2.1 T	pg/g	IAR	1.53	N/A	J	None	Datum is estimated, bias unknown; ion abundance ratio outside acceptance criteria

TABLE 1
DATA QUALIFIERS SUMMARY TABLE
DEMONSTRATION TESTING AND FULL-SCALE OPERATION OF THE BIOGENESIS SEDIMENT DECONTAMINATION PROCESS, KEASBEY, NEW JERSEY
(Page154 of 188)

Location Identification	Sample Identification	Sample Date	Analysis	Analyte	Sample Result	Sample Units	QC Type	QC Result	QC Units	Qualifier	Bias	Comment
WS	WS-170406-1745	04/17/06	SW-846 8290	1,2,3,4,7,8-Hexachlorodibenzofuran	36	pg/g	PDE	N/A	N/A	J	None	Datum is estimated, bias unknown; interfering polychlorinated diphenyl ether peak present
WS	WS-170406-1745	04/17/06	SW-846 8290	1,2,3,7,8-Pentachlorodibenzofuran	6.1 T	pg/g	IAR	1.94	N/A	J	None	Datum is estimated, bias unknown; ion abundance ratio outside acceptance criteria
WS	WS-170406-1745	04/17/06	SW-846 8290	2,3,7,8-Tetrachlorodibenzofuran	11	pg/g	IAR	0.91	N/A	J	None	Datum is estimated, bias unknown; ion abundance ratio outside acceptance criteria
WS	WS-170406-1745	04/17/06	SW-846 8290	Octachlorodibenzo-p-dioxin	2800	pg/g	LB	0.93 T	pg/g	B	None	Analyte detected in associated blank; sample concentration greater than five times the blank concentration
WS	WS-170406-1745	04/17/06	SW-846 8290	Octachlorodibenzofuran	250	pg/g	LB	0.21 T	pg/g	B	None	Analyte detected in associated blank; sample concentration greater than five times the blank concentration
WS	WS-170406-1745	04/17/06	SW-846 8081A	Dieldrin	50	µg/kg	CONF	1000	%	J	None	Datum is estimated, bias unknown; %D between primary and secondary GC columns outside acceptance criterion
WS	WS-170406-1745	04/17/06	SW-846 8081A	beta Endosulfan	87	µg/kg	CONF	80.8	%	J	None	Datum is estimated, bias unknown; %D between primary and secondary GC columns outside acceptance criterion
WS	WS-170406-1745	04/17/06	SW-846 8081A	Endrin	54	µg/kg	CONF	192	%	J	None	Datum is estimated, bias unknown; %D between primary and secondary GC columns outside acceptance criterion
WS	WS-170406-1745	04/17/06	SW-846 8081A	p,p'-DDD	490	µg/kg	CONF	232	%	J	None	Datum is estimated, bias unknown; %D between primary and secondary GC columns outside acceptance criterion
WS	WS-170406-1745	04/17/06	SW-846 8081A	p,p'-DDT	320	µg/kg	CONF	55.7	%	J	None	Datum is estimated, bias unknown; %D between primary and secondary GC columns outside acceptance criterion
PSS	PSS-180406-1700	04/18/06	SW-846 8270 SIM	Fluorene	170 D	µg/kg	CVS	26.3	%	J	None	Datum is estimated, bias unknown; CVS %D outside acceptance criterion
PSS	PSS-180406-1700	04/18/06	SW-846 6010B	Cadmium	5.7	mg/kg	MS MSD	74 72	%	J	Low	Datum is estimated, possible low bias; MS/MSD recoveries outside acceptance criteria
PSS	PSS-180406-1700	04/18/06	SW-846 6010B	Lead	295	mg/kg	MS MSD	4.4 0	%	J	Low	Datum is estimated, possible low bias; MS/MSD recoveries outside acceptance criteria
PSS	PSS-180406-1700	04/18/06	SW-846 6010B	Nickel	40.1	mg/kg	SLD	10.3	%	J	None	Datum is estimated, bias unknown; serial dilution %D outside acceptance criterion
PSS	PSS-180406-1700	04/18/06	SW-846 6010B	Selenium	1.8	mg/kg	SLD	100	%	J	None	Datum is estimated, bias unknown; serial dilution %D outside acceptance criterion
PSS	PSS-180406-1700	04/18/06	SW-846 6010B	Zinc	351	mg/kg	SLD LB	11.6 0.31 T	% mg/kg	JB	None	Datum is estimated, bias unknown; serial dilution percent difference outside acceptance criterion Analyte detected in associated blank; sample concentration greater than five times the blank concentration
RS	RS-180406-1715	04/18/06	SW-846 8270 SIM	Fluorene	96 TD	µg/kg	CVS	26.3	%	J	None	Datum is estimated, bias unknown; CVS %D outside acceptance criterion

TABLE 1
DATA QUALIFIERS SUMMARY TABLE
DEMONSTRATION TESTING AND FULL-SCALE OPERATION OF THE BIOGENESIS SEDIMENT DECONTAMINATION PROCESS, KEASBEY, NEW JERSEY
(Page155 of 188)

Location Identification	Sample Identification	Sample Date	Analysis	Analyte	Sample Result	Sample Units	QC Type	QC Result	QC Units	Qualifier	Bias	Comment
RS	RS-180406-1715	04/18/06	SW-846 6010B	Zinc	474	mg/kg	LB	0 31 T	mg/kg	B	None	Analyte detected in associated blank; sample concentration greater than five times the blank concentration
SS1	SS1-180406-1705	04/18/06	SW-846 8270 SIM	Fluorene	1200 D	µg/kg	CVS	26 3	%	J	None	Datum is estimated, bias unknown; CVS %D outside acceptance criterion
SS1	SS1-180406-1705	04/18/06	SW-846 6010B	Zinc	300	mg/kg	LB	0 31 T	mg/kg	B	None	Analyte detected in associated blank; sample concentration greater than five times the blank concentration
SS2	SS2-180406-1710	04/18/06	SW-846 8270 SIM	Fluorene	1200 D	µg/kg	CVS	26 3	%	J	None	Datum is estimated, bias unknown; CVS %D outside acceptance criterion
SS2	SS2-180406-1710	04/18/06	SW-846 6010B	Zinc	350	mg/kg	LB	0 31 T	mg/kg	B	None	Analyte detected in associated blank; sample concentration greater than five times the blank concentration
TS	TS-180406-1735	04/18/06	SW-846 8270 SIM	Fluorene	96 D	µg/kg	CVS	26 3	%	J	None	Datum is estimated, bias unknown; CVS %D outside acceptance criterion
TS	TS-180406-1735	04/18/06	SW-846 6010B	Zinc	213	mg/kg	LB	0 31 T	mg/kg	B	None	Analyte detected in associated blank; sample concentration greater than five times the blank concentration
TS1	TS1-180406-1720	04/18/06	SW-846 8270 SIM	Anthracene	2100 D	µg/kg	MS	37	%	J	Low	Datum is estimated, possible low bias; MS recovery outside acceptance criteria
TS1	TS1-180406-1720	04/18/06	SW-846 8270 SIM	Benzo(a)anthracene	4000 D	µg/kg	MSD	156	%	J	High	Datum is estimated, possible high bias; MSD recovery outside acceptance criteria
TS1	TS1-180406-1720	04/18/06	SW-846 8270 SIM	Benzo(b)fluoranthene	4400 D	µg/kg	MSD	124	%	J	High	Datum is estimated, possible high bias; MSD recovery outside acceptance criteria
TS1	TS1-180406-1720	04/18/06	SW-846 8270 SIM	Chrysene	4100 D	µg/kg	MSD	136	%	J	High	Datum is estimated, possible high bias; MSD recovery outside acceptance criteria
TS1	TS1-180406-1720	04/18/06	SW-846 8270 SIM	Fluorene	670 D	µg/kg	CVS	26 3	%	J	None	Datum is estimated, bias unknown; CVS %D outside acceptance criterion
TS1	TS1-180406-1720	04/18/06	SW-846 8270 SIM	Phenanthrene	4500 D	µg/kg	MS MSD	171 194	%	J	High	Datum is estimated, possible high bias; MS/MSD recovers outside acceptance criteria
TS1	TS1-180406-1720	04/18/06	SW-846 6010B	Zinc	207	mg/kg	LB	0 31 T	mg/kg	B	None	Analyte detected in associated blank; sample concentration greater than five times the blank concentration
TS2	TS2-180406-1725	04/18/06	SW-846 8270 SIM	Fluorene	120 D	µg/kg	CVS	26 3	%	J	None	Datum is estimated, bias unknown; CVS %D outside acceptance criterion
TS2	TS2-180406-1725	04/18/06	SW-846 6010B	Zinc	168	mg/kg	LB	0 31 T	mg/kg	B	None	Analyte detected in associated blank; sample concentration greater than five times the blank concentration

TABLE 1
DATA QUALIFIERS SUMMARY TABLE
DEMONSTRATION TESTING AND FULL-SCALE OPERATION OF THE BIOGENESIS SEDIMENT DECONTAMINATION PROCESS, KEASBEY, NEW JERSEY
(Page156 of 188)

Location Identification	Sample Identification	Sample Date	Analysis	Analyte	Sample Result	Sample Units	QC Type	QC Result	QC Units	Qualifier	Bias	Comment
TS3	TS3-180406-1730	04/18/06	SW-846 8270 SIM	Fluorene	89 D	µg/kg	CVS	26 3	%	J	None	Datum is estimated, bias unknown; CVS %D outside acceptance criterion
TS3	TS3-180406-1730	04/18/06	SW-846 6010B	Zinc	247	mg/kg	LB	0 31 T	mg/kg	B	None	Analyte detected in associated blank; sample concentration greater than five times the blank concentration
WS	WS-180406-1740	04/18/06	SW-846 8270 SIM	Fluorene	65 TD	µg/kg	CVS	26 3	%	J	None	Datum is estimated, bias unknown; CVS %D outside acceptance criterion
WS	WS-180406-1740	04/18/06	SW-846 6010B	Zinc	784	mg/kg	LB	0 31 T	mg/kg	B	None	Analyte detected in associated blank; sample concentration greater than five times the blank concentration
PSS	PSS-190406-0900	04/19/06	SW-846 8270 SIM	Fluorene	230 TD	µg/kg	CVS	26 3	%	J	None	Datum is estimated, bias unknown; CVS %D outside acceptance criterion
PSS	PSS-190406-0900	04/19/06	SW-846 6010B	Lead	294	mg/kg	MS	73	%	J	Low	Datum is estimated, possible low bias; MS recovery outside acceptance criteria
PSS	PSS-190406-0900	04/19/06	SW-846 6010B	Selenium	2 9	mg/kg	SLD	13 5	%	J	None	Datum is estimated, bias unknown; serial dilution %D outside acceptance criterion
PSS	PSS-190406-0900	04/19/06	SW-846 6010B	Zinc	475	mg/kg	SLD	10 5	%	J	None	Datum is estimated, bias unknown; serial dilution %D outside acceptance criterion
RS	RS-190406-0915	04/19/06	SW-846 8270 SIM	Fluorene	220 TD	µg/kg	CVS	26 3	%	J	None	Datum is estimated, bias unknown; CVS %D outside acceptance criterion
SS1	SS1-190406-0905	04/19/06	SW-846 8270 SIM	Fluorene	920 D	µg/kg	CVS	26 3	%	J	None	Datum is estimated, bias unknown; CVS %D outside acceptance criterion
SS2	SS2-190406-0910	04/19/06	SW-846 8270 SIM	Fluorene	2100 D	µg/kg	CVS	26 3	%	J	None	Datum is estimated, bias unknown; CVS %D outside acceptance criterion
TS	TS-190406-0845	04/19/06	SW-846 8270 SIM	Fluorene	260 D	µg/kg	CVS	26 3	%	J	None	Datum is estimated, bias unknown; CVS %D outside acceptance criterion
TS1	TS1-190406-0845	04/19/06	SW-846 8270 SIM	Fluorene	1000 D	µg/kg	CVS	26 3	%	J	None	Datum is estimated, bias unknown; CVS %D outside acceptance criterion
TS2	TS2-190406-0845	04/19/06	SW-846 8270 SIM	Fluorene	140 D	µg/kg	CVS	26 3	%	J	None	Datum is estimated, bias unknown; CVS %D outside acceptance criterion
TS3	TS3-190406-0845	04/19/06	SW-846 8270 SIM	Fluorene	140 D	µg/kg	CVS	26 3	%	J	None	Datum is estimated, bias unknown; CVS %D outside acceptance criterion
WS	WS-190406-1600	04/19/06	SW-846 8270 SIM	Fluorene	91 TD	µg/kg	CVS	26 3	%	J	None	Datum is estimated, bias unknown; CVS %D outside acceptance criterion
PSS	PSS-200406-1600	04/20/06	SW-846 6010B	Lead	264	mg/kg	MSD	63	%	J	Low	Datum is estimated, possible low bias; MSD recovery outside acceptance criteria

TABLE 1
DATA QUALIFIERS SUMMARY TABLE
DEMONSTRATION TESTING AND FULL-SCALE OPERATION OF THE BIOGENESIS SEDIMENT DECONTAMINATION PROCESS, KEASBEY, NEW JERSEY
(Page157 of 188)

Location Identification	Sample Identification	Sample Date	Analysis	Analyte	Sample Result	Sample Units	QC Type	QC Result	QC Units	Qualifier	Bias	Comment
PSS	PSS-200406-1600	04/20/06	SW-846 6010B	Selenium	2 1	mg/kg	SLD	100	%	J	None	Datum is estimated, bias unknown; serial dilution %D outside acceptance criterion
PSS	PSS-200406-1600	04/20/06	SW-846 6010B	Zinc	372	mg/kg	LB	0 39 T	mg/kg	B	None	Analyte detected in associated blank; sample concentration greater than five times the blank concentration
PSS	PSS-200406-1600	04/20/06	SW-846 8082	2,2',3,4,4',5,5'-Heptachlorobiphenyl	9 1 D	µg/kg	CONF	48 3	%	J	None	Datum is estimated, bias unknown; %D between primary and secondary GC columns outside acceptance criterion
PSS	PSS-200406-1600	04/20/06	SW-846 8082	2,2',3,4,5'-Pentachlorobiphenyl	8 2 D	µg/kg	CONF	1000	%	J	None	Datum is estimated, bias unknown; %D between primary and secondary GC columns outside acceptance criterion
PSS	PSS-200406-1600	04/20/06	SW-846 8082	2,2',5,5'-Tetrachlorobiphenyl	29 D	µg/kg	CONF	81	%	J	None	Datum is estimated, bias unknown; %D between primary and secondary GC columns outside acceptance criterion
PSS	PSS-200406-1600	04/20/06	SW-846 8082	2-Chlorobiphenyl	22 TD	µg/kg	CONF LB	206 0 18 T	% µg/kg	JB	None	Datum is estimated, bias unknown; %D between primary and secondary GC columns outside acceptance criterion Analyte detected in associated blank; sample concentration greater than five times the blank concentration
PSS	PSS-200406-1600	04/20/06	SW-846 8290	2,3,4,6,7,8-Hexachlorodibenzofuran	29	pg/g	LCS	127	%	J	High	Datum is estimated, possible high bias; LCS recovery outside acceptance criteria
PSS	PSS-200406-1600	04/20/06	SW-846 8081A	Endrin	34	µg/kg	CONF	136	%	J	None	Datum is estimated, bias unknown; %D between primary and secondary GC columns outside acceptance criterion
PSS	PSS-200406-1600	04/20/06	SW-846 8081A	p,p'-DDD	290	µg/kg	CONF	118	%	J	None	Datum is estimated, bias unknown; %D between primary and secondary GC columns outside acceptance criterion
RS	RS-200406-1615	04/20/06	Lloyd Kahn	Total organic carbon	10800	mg/kg	CVS	74	%	J	High	Datum is estimated, bias unknown; CVS %D outside acceptance criterion
RS	RS-200406-1615	04/20/06	SW-846 6010B	Zinc	505	mg/kg	LB	0 39 T	mg/kg	B	None	Analyte detected in associated blank; sample concentration greater than five times the blank concentration
RS	RS-200406-1615	04/20/06	SW-846 7471A	Mercury	8 5	mg/kg	CCB	0 2	µg/l	B	None	Analyte detected in associated blank; sample concentration greater than five times the blank concentration
RS	RS-200406-1615	04/20/06	SW-846 8082	2,2',3,4',5,5',6-Heptachlorobiphenyl	14 D	µg/kg	CVS	16 7	%	J	None	Datum is estimated, bias unknown; CVS %D outside acceptance criterion
RS	RS-200406-1615	04/20/06	SW-846 8082	2,2',3,4,4',5,5'-Heptachlorobiphenyl	13 D	µg/kg	CONF	64 4	%	J	None	Datum is estimated, bias unknown; %D between primary and secondary GC columns outside acceptance criterion
RS	RS-200406-1615	04/20/06	SW-846 8082	2,2',4,4',5,5'-Hexachlorobiphenyl	24 D	µg/kg	CVS	16 4	%	J	None	Datum is estimated, bias unknown; CVS %D outside acceptance criterion
RS	RS-200406-1615	04/20/06	SW-846 8082	2,2',5,5'-Tetrachlorobiphenyl	43 D	µg/kg	CONF	84 9	%	J	None	Datum is estimated, bias unknown; %D between primary and secondary GC columns outside acceptance criterion

TABLE 1
DATA QUALIFIERS SUMMARY TABLE
DEMONSTRATION TESTING AND FULL-SCALE OPERATION OF THE BIOGENESIS SEDIMENT DECONTAMINATION PROCESS, KEASBEY, NEW JERSEY
(Page158 of 188)

Location Identification	Sample Identification	Sample Date	Analysis	Analyte	Sample Result	Sample Units	QC Type	QC Result	QC Units	Qualifier	Bias	Comment
RS	RS-200406-1615	04/20/06	SW-846 8082	2-Chlorobiphenyl	120 D	µg/kg	CONF	177	%	J	None	Datum is estimated, bias unknown; %D between primary and secondary GC columns outside acceptance criterion
RS	RS-200406-1615	04/20/06	SW-846 8290	1,2,3,4,7,8-Hexachlorodibenzofuran	72	pg/g	PDE	N/A	N/A	J	None	Datum is estimated, bias unknown; interfering polychlorinated diphenyl ether peak present
RS	RS-200406-1615	04/20/06	SW-846 8290	1,2,3,6,7,8-Hexachlorodibenzofuran	25	pg/g	PDE	N/A	N/A	J	None	Datum is estimated, bias unknown; interfering polychlorinated diphenyl ether peak present
RS	RS-200406-1615	04/20/06	SW-846 8290	1,2,3,7,8,9-Hexachlorodibenzofuran	3.1 T	pg/g	IAR LB	1.62 0.12 T	N/A pg/g	JB	None	Datum is estimated, bias unknown; ion abundance ratio outside acceptance criteria Analyte detected in associated blank; sample concentration greater than five times the blank concentration
RS	RS-200406-1615	04/20/06	SW-846 8290	1,2,3,7,8-Pentachlorodibenzo-p-dioxin	4.0 T	pg/g	IAR	1.15	N/A	J	None	Datum is estimated, bias unknown; ion abundance ratio outside acceptance criteria
RS	RS-200406-1615	04/20/06	SW-846 8290	1,2,3,7,8-Pentachlorodibenzofuran	13 T	pg/g	IAR	1.83	N/A	J	None	Datum is estimated, bias unknown; ion abundance ratio outside acceptance criteria
RS	RS-200406-1615	04/20/06	SW-846 8290	2,3,4,6,7,8-Hexachlorodibenzofuran	16 T	pg/g	PDE	N/A	N/A	J	None	Datum is estimated, bias unknown; interfering polychlorinated diphenyl ether peak present
RS	RS-200406-1615	04/20/06	SW-846 8290	Octachlorodibenzo-p-dioxin	5500	pg/g	LB	0.93 T	pg/g	B	None	Analyte detected in associated blank; sample concentration greater than five times the blank concentration
RS	RS-200406-1615	04/20/06	SW-846 8290	Octachlorodibenzofuran	440	pg/g	LB	0.21 T	pg/g	B	None	Analyte detected in associated blank; sample concentration greater than five times the blank concentration
RS	RS-200406-1615	04/20/06	SW-846 8081A	p,p'-DDD	240	µg/kg	CONF	240	%	J	None	Datum is estimated, bias unknown; %D between primary and secondary GC columns outside acceptance criterion
RS	RS-200406-1615	04/20/06	SW-846 8081A	p,p'-DDT	300	µg/kg	CONF	53.3	%	J	None	Datum is estimated, bias unknown; %D between primary and secondary GC columns outside acceptance criterion
SS1	SS1-200406-1605	04/20/06	SW-846 6010B	Zinc	269	mg/kg	LB	0.39 T	mg/kg	B	None	Analyte detected in associated blank; sample concentration greater than five times the blank concentration
SS2	SS2-200406-1610	04/20/06	Lloyd Kahn	Total organic carbon	110000	mg/kg	CVS	74	%	J	High	Datum is estimated, bias unknown; CVS %D outside acceptance criterion
SS2	SS2-200406-1610	04/20/06	SW-846 6010B	Zinc	300	mg/kg	LB	0.39 T	mg/kg	B	None	Analyte detected in associated blank; sample concentration greater than five times the blank concentration
TS	TS-200406-1635	04/20/06	SW-846 8270 SIM	Benzo(a)anthracene	1500 D	µg/kg	MSD	37	%	J	Low	Datum is estimated, possible low bias; MSD recovery outside acceptance criteria
TS	TS-200406-1635	04/20/06	SW-846 8270 SIM	Benzo(a)pyrene	1400 D	µg/kg	MSD	34	%	J	Low	Datum is estimated, possible low bias; MSD recovery outside acceptance criteria
TS	TS-200406-1635	04/20/06	SW-846 8270 SIM	Benzo(b)fluoranthene	1600 D	µg/kg	MS MSD	22 28	%	J	Low	Datum is estimated, possible low bias; MS/MSD recoveries outside acceptance criteria

TABLE 1
DATA QUALIFIERS SUMMARY TABLE
DEMONSTRATION TESTING AND FULL-SCALE OPERATION OF THE BIOGENESIS SEDIMENT DECONTAMINATION PROCESS, KEASBEY, NEW JERSEY
(Page159 of 188)

Location Identification	Sample Identification	Sample Date	Analysis	Analyte	Sample Result	Sample Units	QC Type	QC Result	QC Units	Qualifier	Bias	Comment
TS	TS-200406-1635	04/20/06	SW-846 8270 SIM	Fluoranthene	2300 D	µg/kg	MS MSD	29 21	%	J	Low	Datum is estimated, possible low bias; MS/MSD recoveries outside acceptance criteria
TS	TS-200406-1635	04/20/06	SW-846 8270 SIM	Naphthalene	320 D	µg/kg	MS MSD	36 35	%	J	Low	Datum is estimated, possible low bias; MS/MSD recoveries outside acceptance criteria
TS	TS-200406-1635	04/20/06	SW-846 8270 SIM	Phenanthrene	1200 D	µg/kg	MS MSD	36 37	%	J	Low	Datum is estimated, possible low bias; MS/MSD recoveries outside acceptance criteria
TS	TS-200406-1635	04/20/06	SW-846 8270 SIM	Pyrene	2300 D	µg/kg	MS MSD	29 20	%	J	Low	Datum is estimated, possible low bias; MS/MSD recoveries outside acceptance criteria
TS	TS-200406-1635	04/20/06	Lloyd Kahn	Total organic carbon	20000	mg/kg	CVS	74	%	J	High	Datum is estimated, bias unknown; CVS %D outside acceptance criterion
TS	TS-200406-1635	04/20/06	SW-846 6010B	Zinc	251	mg/kg	LB	0.39 T	mg/kg	B	None	Analyte detected in associated blank; sample concentration greater than five times the blank concentration
TS	TS-200406-1635	04/20/06	SW-846 8082	2,2',3,4',5,5',6-Heptachlorobiphenyl	7.2 D	µg/kg	CVS	16.7	%	J	None	Datum is estimated, bias unknown; CVS %D outside acceptance criterion
TS	TS-200406-1635	04/20/06	SW-846 8082	2,2',3,4,4',5,5'-Heptachlorobiphenyl	5.7 D	µg/kg	CONF	16.7	%	J	None	Datum is estimated, bias unknown; %D between primary and secondary GC columns outside acceptance criterion
TS	TS-200406-1635	04/20/06	SW-846 8082	2,2',4,4',5,5'-Hexachlorobiphenyl	15 D	µg/kg	CVS	16.4	%	J	None	Datum is estimated, bias unknown; CVS %D outside acceptance criterion
TS	TS-200406-1635	04/20/06	SW-846 8082	2,2',5,5'-Tetrachlorobiphenyl	21 D	µg/kg	CONF	99.8	%	J	None	Datum is estimated, bias unknown; %D between primary and secondary GC columns outside acceptance criterion
TS	TS-200406-1635	04/20/06	SW-846 8270C	2,4,6-Trichlorophenol	<1200 D	µg/kg	MS	44	%	UJ	Low	Possible false negative; MS recovery outside acceptance criteria
TS	TS-200406-1635	04/20/06	SW-846 8270C	2,4-Dinitrotoluene	<1200 D	µg/kg	MS MSD	35 33	%	UJ	Low	Possible false negative; MS/MSD recoveries outside acceptance criteria
TS	TS-200406-1635	04/20/06	SW-846 8270C	Acenaphthylene	390 TD	µg/kg	MS	44	%	J	Low	Datum is estimated, possible low bias; MS recovery outside acceptance criteria
TS	TS-200406-1635	04/20/06	SW-846 8270C	Anthracene	570 TD	µg/kg	MS	38	%	J	Low	Datum is estimated, possible low bias; MS recovery outside acceptance criteria
TS	TS-200406-1635	04/20/06	SW-846 8270C	Benzo(a)anthracene	1000 TD	µg/kg	MS MSD	41 51	%	J	Low	Datum is estimated, possible low bias; MS/MSD recoveries outside acceptance criteria
TS	TS-200406-1635	04/20/06	SW-846 8270C	Benzo(a)pyrene	1100 TD	µg/kg	MS MSD	36 49	%	J	Low	Datum is estimated, possible low bias; MS/MSD recoveries outside acceptance criteria
TS	TS-200406-1635	04/20/06	SW-846 8270C	Benzo(b)fluoranthene	1200 D	µg/kg	MS	34	%	J	Low	Datum is estimated, possible low bias; MS recovery outside acceptance criteria
TS	TS-200406-1635	04/20/06	SW-846 8270C	Benzo(g,h,i)perylene	710 TD	µg/kg	MS MSD	29 26	%	J	Low	Datum is estimated, possible low bias; MS/MSD recoveries outside acceptance criteria
TS	TS-200406-1635	04/20/06	SW-846 8270C	Benzo(k)fluoranthene	510 TD	µg/kg	MS MSD	40 50	%	J	Low	Datum is estimated, possible low bias; MS/MSD recoveries outside acceptance criteria
TS	TS-200406-1635	04/20/06	SW-846 8270C	Chrysene	1200 D	µg/kg	MS	37	%	J	Low	Datum is estimated, possible low bias; MS recovery outside acceptance criteria

TABLE 1
DATA QUALIFIERS SUMMARY TABLE
DEMONSTRATION TESTING AND FULL-SCALE OPERATION OF THE BIOGENESIS SEDIMENT DECONTAMINATION PROCESS, KEASBEY, NEW JERSEY
(Page160 of 188)

Location Identification	Sample Identification	Sample Date	Analysis	Analyte	Sample Result	Sample Units	QC Type	QC Result	QC Units	Qualifier	Bias	Comment
TS	TS-200406-1635	04/20/06	SW-846 8270C	Dibenz(a,h)anthracene	140 TD	µg/kg	MS	42	%	J	Low	Datum is estimated, possible low bias; MS recovery outside acceptance criteria
TS	TS-200406-1635	04/20/06	SW-846 8270C	Fluoranthene	2400 D	µg/kg	MS MSD	17 29	%	J	Low	Datum is estimated, possible low bias; MS/MSD recoveries outside acceptance criteria
TS	TS-200406-1635	04/20/06	SW-846 8270C	Fluorene	210 TD	µg/kg	MS	43	%	J	Low	Datum is estimated, possible low bias; MS recovery outside acceptance criteria
TS	TS-200406-1635	04/20/06	SW-846 8270C	Hexachlorobenzene	<1200 D	µg/kg	MS MSD	41 46	%	UJ	Low	Possible false negative; MS/MSD recoveries outside acceptance criteria
TS	TS-200406-1635	04/20/06	SW-846 8270C	Hexachloroethane	<1200 D	µg/kg	MS MSD	20 16	%	UJ	Low	Possible false negative; MS/MSD recoveries outside acceptance criteria
TS	TS-200406-1635	04/20/06	SW-846 8270C	Indeno(1,2,3-c,d)pyrene	750 TD	µg/kg	MS MSD	29 30	%	J	Low	Datum is estimated, possible low bias; MS/MSD recoveries outside acceptance criteria
TS	TS-200406-1635	04/20/06	SW-846 8270C	Naphthalene	320 TD	µg/kg	MS MSD	37 42	%	J	Low	Datum is estimated, possible low bias; MS/MSD recoveries outside acceptance criteria
TS	TS-200406-1635	04/20/06	SW-846 8270C	Pyrene	1900 D	µg/kg	MS	20	%	J	Low	Datum is estimated, possible low bias; MS recovery outside acceptance criteria
TS	TS-200406-1635	04/20/06	SW-846 8290	1,2,3,4,7,8,9-Heptachlorodibenzofuran	1 3 T	pg/g	IAR	1 21	N/A	J	None	Datum is estimated, bias unknown; ion abundance ratio outside acceptance criteria
TS	TS-200406-1635	04/20/06	SW-846 8290	1,2,3,4,7,8-Hexachlorodibenzo-p-dioxin	0 29 T	pg/g	IAR	0 72	N/A	J	None	Datum is estimated, bias unknown; ion abundance ratio outside acceptance criteria
TS	TS-200406-1635	04/20/06	SW-846 8290	1,2,3,4,7,8-Hexachlorodibenzofuran	4 5 T	pg/g	PDE	N/A	N/A	J	None	Datum is estimated, bias unknown; interfering polychlorinated diphenyl ether peak present
TS	TS-200406-1635	04/20/06	SW-846 8290	2,3,4,7,8-Pentachlorodibenzofuran	1 3 T	pg/g	IAR	1 23	N/A	J	None	Datum is estimated, bias unknown; ion abundance ratio outside acceptance criteria
TS	TS-200406-1635	04/20/06	SW-846 8290	2,3,7,8-Tetrachlorodibenzofuran	2 7	pg/g	PDE	N/A	N/A	J	None	Datum is estimated, bias unknown; interfering polychlorinated diphenyl ether peak present
TS	TS-200406-1635	04/20/06	SW-846 8290	Octachlorodibenzo-p-dioxin	280	pg/g	MS LB	52 0 93 T	% pg/g	JB	Low	Datum is estimated, possible low bias; MS recovery outside acceptance criterion Analyte detected in associated blank; sample concentration greater than five times the blank concentration
TS	TS-200406-1635	04/20/06	SW-846 8290	Octachlorodibenzofuran	21	pg/g	LB	0 21 T	pg/g	B	None	Analyte detected in associated blank; sample concentration greater than five times the blank concentration
TS	TS-200406-1635	04/20/06	SW-846 8081A	Dieldrin	16	µg/kg	CONF	943	%	J	None	Datum is estimated, bias unknown; %D between primary and secondary GC columns outside acceptance criterion
TS	TS-200406-1635	04/20/06	SW-846 8081A	Endrin	19	µg/kg	CONF	182	%	J	None	Datum is estimated, bias unknown; %D between primary and secondary GC columns outside acceptance criterion
TS	TS-200406-1635	04/20/06	SW-846 8081A	p,p'-DDD	250	µg/kg	CONF	87 9	%	J	None	Datum is estimated, bias unknown; %D between primary and secondary GC columns outside acceptance criterion

TABLE 1
DATA QUALIFIERS SUMMARY TABLE
DEMONSTRATION TESTING AND FULL-SCALE OPERATION OF THE BIOGENESIS SEDIMENT DECONTAMINATION PROCESS, KEASBEY, NEW JERSEY
(Page 161 of 188)

Location Identification	Sample Identification	Sample Date	Analysis	Analyte	Sample Result	Sample Units	QC Type	QC Result	QC Units	Qualifier	Bias	Comment
TS1	TS1-200406-1620	04/20/06	Lloyd Kahn	Total organic carbon	63700	mg/kg	CVS	74	%	J	High	Datum is estimated, bias unknown; CVS %D outside acceptance criterion
TS1	TS1-200406-1620	04/20/06	SW-846 6010B	Zinc	199	mg/kg	LB	0.39 T	mg/kg	B	None	Analyte detected in associated blank; sample concentration greater than five times the blank concentration
TS1	TS1-200406-1620	04/20/06	SW-846 7471A	Mercury	1.1	mg/kg	CCB	0.2	µg/l	B	None	Analyte detected in associated blank; sample concentration greater than five times the blank concentration
TS2	TS2-200406-1625	04/20/06	Lloyd Kahn	Total organic carbon	8600	mg/kg	CVS	74	%	J	High	Datum is estimated, bias unknown; CVS %D outside acceptance criterion
TS2	TS2-200406-1625	04/20/06	SW-846 6010B	Zinc	162	mg/kg	LB	0.39 T	mg/kg	B	None	Analyte detected in associated blank; sample concentration greater than five times the blank concentration
TS3	TS3-200406-1630	04/20/06	Lloyd Kahn	Total organic carbon	27400	mg/kg	CVS	74	%	J	High	Datum is estimated, bias unknown; CVS %D outside acceptance criterion
TS3	TS3-200406-1630	04/20/06	SW-846 6010B	Zinc	250	mg/kg	LB	0.39 T	mg/kg	B	None	Analyte detected in associated blank; sample concentration greater than five times the blank concentration
WS	WS-200406-1640	04/20/06	SW-846 6010B	Zinc	757	mg/kg	LB	0.39 T	mg/kg	B	None	Analyte detected in associated blank; sample concentration greater than five times the blank concentration
WS	WS-200406-1640	04/20/06	SW-846 8082	2,2',3,4',5,5',6-Heptachlorobiphenyl	23 D	µg/kg	CVS	16.7	%	J	None	Datum is estimated, bias unknown; CVS %D outside acceptance criterion
WS	WS-200406-1640	04/20/06	SW-846 8082	2,2',3,4,4',5,5'-Heptachlorobiphenyl	20 D	µg/kg	CONF	52.8	%	J	None	Datum is estimated, bias unknown; %D between primary and secondary GC columns outside acceptance criterion
WS	WS-200406-1640	04/20/06	SW-846 8082	2,2',4,4',5,5'-Hexachlorobiphenyl	41 D	µg/kg	CVS	16.4	%	J	None	Datum is estimated, bias unknown; CVS %D outside acceptance criterion
WS	WS-200406-1640	04/20/06	SW-846 8082	2,2',5,5'-Tetrachlorobiphenyl	69 D	µg/kg	CONF	16.7	%	J	None	Datum is estimated, bias unknown; %D between primary and secondary GC columns outside acceptance criterion
WS	WS-200406-1640	04/20/06	SW-846 8290	1,2,3,4,7,8-Hexachlorodibenzofuran	19	pg/g	PDE	N/A	N/A	J	None	Datum is estimated, bias unknown; interfering polychlorinated diphenyl ether peak present
WS	WS-200406-1640	04/20/06	SW-846 8290	1,2,3,7,8-Pentachlorodibenzo-p-dioxin	1.2 T	pg/g	IAR	2.03	N/A	J	None	Datum is estimated, bias unknown; ion abundance ratio outside acceptance criteria
WS	WS-200406-1640	04/20/06	SW-846 8290	2,3,7,8-Tetrachlorodibenzofuran	5.5	pg/g	IAR	1.01	N/A	J	None	Datum is estimated, bias unknown; ion abundance ratio outside acceptance criteria
WS	WS-200406-1640	04/20/06	SW-846 8290	Octachlorodibenzo-p-dioxin	1400	pg/g	LB	0.93 T	pg/g	B	None	Analyte detected in associated blank; sample concentration greater than five times the blank concentration

TABLE 1
DATA QUALIFIERS SUMMARY TABLE
DEMONSTRATION TESTING AND FULL-SCALE OPERATION OF THE BIOGENESIS SEDIMENT DECONTAMINATION PROCESS, KEASBEY, NEW JERSEY
(Page 162 of 188)

Location Identification	Sample Identification	Sample Date	Analysis	Analyte	Sample Result	Sample Units	QC Type	QC Result	QC Units	Qualifier	Bias	Comment
WS	WS-200406-1640	04/20/06	SW-846 8290	Octachlorodibenzofuran	110	pg/g	LB	0.21 T	pg/g	B	None	Analyte detected in associated blank; sample concentration greater than five times the blank concentration
WS	WS-200406-1640	04/20/06	SW-846 8081A	p,p'-DDD	270	µg/kg	CONF	184	%	J	None	Datum is estimated, bias unknown; %D between primary and secondary GC columns outside acceptance criterion
PSS	PSS-210406-1400	04/21/06	Lloyd Kahn	Total organic carbon	65300	mg/kg	CVS	114	%	J	High	Datum is estimated, bias unknown; CVS %D outside acceptance criterion
PSS	PSS-210406-1400	04/21/06	SW-846 6010B	Arsenic	30.5	mg/kg	SLD	12.4	%	J	None	Datum is estimated, bias unknown; serial dilution %D outside acceptance criterion
PSS	PSS-210406-1400	04/21/06	SW-846 6010B	Lead	260	mg/kg	SLD	12.1	%	J	None	Datum is estimated, bias unknown; serial dilution %D outside acceptance criterion
PSS	PSS-210406-1400	04/21/06	SW-846 6010B	Nickel	46.4	mg/kg	SLD	11.1	%	J	None	Datum is estimated, bias unknown; serial dilution %D outside acceptance criterion
PSS	PSS-210406-1400	04/21/06	SW-846 6010B	Selenium	2.4	mg/kg	SLD	39.5	%	J	None	Datum is estimated, bias unknown; serial dilution %D outside acceptance criterion
PSS	PSS-210406-1400	04/21/06	SW-846 6010B	Zinc	393	mg/kg	SLD	14.7	%	J	None	Datum is estimated, bias unknown; serial dilution %D outside acceptance criterion
RS	RS-210406-1415	04/21/06	Lloyd Kahn	Total organic carbon	135000	mg/kg	CVS	114	%	J	High	Datum is estimated, bias unknown; CVS %D outside acceptance criterion
SS1	SS1-210406-1405	04/21/06	Lloyd Kahn	Total organic carbon	490000	mg/kg	CVS	114	%	J	High	Datum is estimated, bias unknown; CVS %D outside acceptance criterion
SS2	SS2-210406-1410	04/21/06	Lloyd Kahn	Total organic carbon	53200	mg/kg	CVS	114	%	J	High	Datum is estimated, bias unknown; CVS %D outside acceptance criterion
TS1	TS1-210406-1420	04/21/06	SW-846 8270 SIM	Anthracene	2100 D	µg/kg	MS MSD	149 157	%	J	High	Datum is estimated, possible high bias; MS/MSD recoveries outside acceptance criteria
TS1	TS1-210406-1420	04/21/06	SW-846 8270 SIM	Benzo(a)anthracene	4400 D	µg/kg	MS MSD	132 168	%	J	High	Datum is estimated, possible high bias; MS/MSD recoveries outside acceptance criteria
TS1	TS1-210406-1420	04/21/06	SW-846 8270 SIM	Benzo(a)pyrene	4100 D	µg/kg	MS MSD	123 127	%	J	High	Datum is estimated, possible high bias; MS/MSD recoveries outside acceptance criteria
TS1	TS1-210406-1420	04/21/06	SW-846 8270 SIM	Chrysene	4300 D	µg/kg	MS MSD	156 140	%	J	High	Datum is estimated, possible high bias; MS/MSD recoveries outside acceptance criteria
TS1	TS1-210406-1420	04/21/06	Lloyd Kahn	Total organic carbon	48700	mg/kg	CVS	114	%	J	High	Datum is estimated, bias unknown; CVS %D outside acceptance criterion
TS2	TS2-210406-1425	04/21/06	Lloyd Kahn	Total organic carbon	21100	mg/kg	CVS	114	%	J	High	Datum is estimated, bias unknown; CVS %D outside acceptance criterion
RS	INF1-250406-1845	04/24/06	Lloyd Kahn	Total organic carbon	59100	mg/kg	HT	15	days	J	Low	Datum is estimated, possible low bias; preparation and analysis holding times exceeded

TABLE 1
DATA QUALIFIERS SUMMARY TABLE
DEMONSTRATION TESTING AND FULL-SCALE OPERATION OF THE BIOGENESIS SEDIMENT DECONTAMINATION PROCESS, KEASBEY, NEW JERSEY
(Page 163 of 188)

Location Identification	Sample Identification	Sample Date	Analysis	Analyte	Sample Result	Sample Units	QC Type	QC Result	QC Units	Qualifier	Bias	Comment
RS	INF1-250406-1845	04/24/06	SW-846 6010B	Zinc	462	mg/kg	LB	0.22 T	mg/kg	B	None	Analyte detected in associated blank; sample concentration greater than five times the blank concentration
PSS	PSS-240406-1600	04/24/06	SW-846 6010B	Cadmium	7.1	mg/kg	MS	73	%	J	Low	Datum is estimated, possible low bias; MS recovery outside acceptance criteria
PSS	PSS-240406-1600	04/24/06	SW-846 6010B	Lead	314	mg/kg	MS	67	%	J	Low	Datum is estimated, possible low bias; MS recovery outside acceptance criteria
PSS	PSS-240406-1600	04/24/06	SW-846 6010B	Selenium	2.7	mg/kg	SLD	14.9	%	J	None	Datum is estimated, bias unknown; serial dilution %D outside acceptance criterion
PSS	PSS-240406-1600	04/24/06	SW-846 6010B	Zinc	497	mg/kg	SLD	12	%	J	None	Datum is estimated, bias unknown; serial dilution %D outside acceptance criterion
TS1	TS1-240406-1620	04/24/06	SW-846 8270 SIM	Benzo(a)anthracene	6300 D	µg/kg	MSD	141	%	J	High	Datum is estimated, possible high bias; MSD recovery outside acceptance criteria
TS1	TS1-240406-1620	04/24/06	SW-846 8270 SIM	Benzo(b)fluoranthene	6200 D	µg/kg	MSD	136	%	J	High	Datum is estimated, possible high bias; MSD recovery outside acceptance criteria
TS1	TS1-240406-1620	04/24/06	SW-846 8270 SIM	Benzo(g,h,i)perylene	3700 D	µg/kg	MSD	155	%	J	High	Datum is estimated, possible high bias; MSD recovery outside acceptance criteria
TS1	TS1-240406-1620	04/24/06	SW-846 8270 SIM	Benzo(k)fluoranthene	2200 D	µg/kg	MSD	131	%	J	High	Datum is estimated, possible high bias; MSD recovery outside acceptance criteria
TS1	TS1-240406-1620	04/24/06	SW-846 8270 SIM	Indeno(1,2,3-c,d)pyrene	3300 D	µg/kg	MSD	140	%	J	High	Datum is estimated, possible high bias; MSD recovery outside acceptance criteria
PSS	PSS-250406-1800	04/25/06	SW-846 6010B	Barium	368	mg/kg	MSD	70	%	J	Low	Datum is estimated, possible low bias; MSD recovery outside acceptance criteria
PSS	PSS-250406-1800	04/25/06	SW-846 6010B	Lead	275	mg/kg	MS MSD	33 47	%	J	Low	Datum is estimated, possible low bias; MS/MSD recoveries outside acceptance criteria
PSS	PSS-250406-1800	04/25/06	SW-846 6010B	Nickel	45.2	mg/kg	SLD	11.2	%	J	None	Datum is estimated, bias unknown; serial dilution %D outside acceptance criterion
PSS	PSS-250406-1800	04/25/06	SW-846 6010B	Selenium	1.9	mg/kg	SLD	45	%	J	None	Datum is estimated, bias unknown; serial dilution %D outside acceptance criterion
PSS	PSS-250406-1800	04/25/06	SW-846 6010B	Zinc	395	mg/kg	SLD LB	12.9 0.22 T	% mg/kg	JB	None	Datum is estimated, bias unknown; serial dilution percent difference outside acceptance criterion Analyte detected in associated blank; sample concentration greater than five times the blank concentration
RS	RS-250406-1815	04/25/06	SW-846 6010B	Zinc	388	mg/kg	LB	0.22 T	mg/kg	B	None	Analyte detected in associated blank; sample concentration greater than five times the blank concentration
RS	RS-250406-1815	04/25/06	SW-846 8082	2,2',3,4',5,5',6-Heptachlorobiphenyl	13 D	µg/kg	CVS	21	%	J	None	Datum is estimated, bias unknown; CVS %D outside acceptance criterion

TABLE 1
DATA QUALIFIERS SUMMARY TABLE
DEMONSTRATION TESTING AND FULL-SCALE OPERATION OF THE BIOGENESIS SEDIMENT DECONTAMINATION PROCESS, KEASBEY, NEW JERSEY
(Page164 of 188)

Location Identification	Sample Identification	Sample Date	Analysis	Analyte	Sample Result	Sample Units	QC Type	QC Result	QC Units	Qualifier	Bias	Comment
RS	RS-250406-1815	04/25/06	SW-846 8082	2,2',3,4,4',5,5'-Heptachlorobiphenyl	13 D	µg/kg	CONF	58 1	%	J	None	Datum is estimated, bias unknown; %D between primary and secondary GC columns outside acceptance criterion
RS	RS-250406-1815	04/25/06	SW-846 8082	2,2',3,4,5'-Pentachlorobiphenyl	13 D	µg/kg	CONF	1000	%	J	None	Datum is estimated, bias unknown; %D between primary and secondary GC columns outside acceptance criterion
RS	RS-250406-1815	04/25/06	SW-846 8082	2,2',4,4',5,5'-Hexachlorobiphenyl	23 D	µg/kg	CVS	16 3	%	J	None	Datum is estimated, bias unknown; CVS %D outside acceptance criterion
RS	RS-250406-1815	04/25/06	SW-846 8082	2,2',5,5'-Tetrachlorobiphenyl	41 D	µg/kg	CONF	153	%	J	None	Datum is estimated, bias unknown; %D between primary and secondary GC columns outside acceptance criterion
RS	RS-250406-1815	04/25/06	SW-846 8082	2,4,5-Trichlorobiphenyl	49 D	µg/kg	CONF	583	%	J	None	Datum is estimated, bias unknown; %D between primary and secondary GC columns outside acceptance criterion
RS	RS-250406-1815	04/25/06	SW-846 8082	2-Chlorobiphenyl	110 D	µg/kg	CONF LB	108 0 22 T	% µg/kg	JB	None	Datum is estimated, bias unknown; %D between primary and secondary GC columns outside acceptance criterion Analyte detected in associated blank; sample concentration greater than five times the blank concentration
RS	RS-250406-1815	04/25/06	SW-846 8290	1,2,3,4,7,8-Hexachlorodibenzofuran	94	pg/g	PDE	N/A	N/A	J	None	Datum is estimated, bias unknown; interfering polychlorinated diphenyl ether peak present
RS	RS-250406-1815	04/25/06	SW-846 8290	1,2,3,7,8,9-Hexachlorodibenzofuran	2 1 T	pg/g	LB	0 12 T	pg/g	B	None	Analyte detected in associated blank; sample concentration greater than five times the blank concentration
RS	RS-250406-1815	04/25/06	SW-846 8290	1,2,3,7,8-Pentachlorodibenzofuran	14 T	pg/g	IAR	1 89	N/A	J	None	Datum is estimated, bias unknown; ion abundance ratio outside acceptance criteria
RS	RS-250406-1815	04/25/06	SW-846 8290	2,3,4,6,7,8-Hexachlorodibenzofuran	20	pg/g	PDE	N/A	N/A	J	None	Datum is estimated, bias unknown; interfering polychlorinated diphenyl ether peak present
RS	RS-250406-1815	04/25/06	SW-846 8290	2,3,7,8-Tetrachlorodibenzofuran	28	pg/g	PDE	N/A	N/A	J	None	Datum is estimated, bias unknown; interfering polychlorinated diphenyl ether peak present
RS	RS-250406-1815	04/25/06	SW-846 8290	Octachlorodibenzo-p-dioxin	6200	pg/g	LB	0 93 T	pg/g	B	None	Analyte detected in associated blank; sample concentration greater than five times the blank concentration
RS	RS-250406-1815	04/25/06	SW-846 8290	Octachlorodibenzofuran	920	pg/g	LB	0 21 T	pg/g	B	None	Analyte detected in associated blank; sample concentration greater than five times the blank concentration
RS	RS-250406-1815	04/25/06	SW-846 8081A	Dieldrin	13	µg/kg	CONF	1000	%	J	None	Datum is estimated, bias unknown; %D between primary and secondary GC columns outside acceptance criterion
RS	RS-250406-1815	04/25/06	SW-846 8081A	beta Endosulfan	48	µg/kg	CONF	56 4	%	J	None	Datum is estimated, bias unknown; %D between primary and secondary GC columns outside acceptance criterion
RS	RS-250406-1815	04/25/06	SW-846 8081A	Endrin aldehyde	26	µg/kg	CONF	1000	%	J	None	Datum is estimated, bias unknown; %D between primary and secondary GC columns outside acceptance criterion
RS	RS-250406-1815	04/25/06	SW-846 8081A	Alpha-Chlordane	17	µg/kg	CONF	745	%	J	None	Datum is estimated, bias unknown; %D between primary and secondary GC columns outside acceptance criterion

TABLE 1
DATA QUALIFIERS SUMMARY TABLE
DEMONSTRATION TESTING AND FULL-SCALE OPERATION OF THE BIOGENESIS SEDIMENT DECONTAMINATION PROCESS, KEASBEY, NEW JERSEY
(Page 165 of 188)

Location Identification	Sample Identification	Sample Date	Analysis	Analyte	Sample Result	Sample Units	QC Type	QC Result	QC Units	Qualifier	Bias	Comment
RS	RS-250406-1815	04/25/06	SW-846 8081A	p,p'-DDD	250	µg/kg	CONF	196	%	J	None	Datum is estimated, bias unknown; %D between primary and secondary GC columns outside acceptance criterion
SS2	SS2-250406-1810	04/25/06	SW-846 6010B	Zinc	286	mg/kg	LB	0.22 T	mg/kg	B	None	Analyte detected in associated blank; sample concentration greater than five times the blank concentration
TS	TS-250406-1835	04/25/06	SW-846 6010B	Zinc	228	mg/kg	LB	0.22 T	mg/kg	B	None	Analyte detected in associated blank; sample concentration greater than five times the blank concentration
TS	TS-250406-1835	04/25/06	SW-846 8082	2,2',3,4',5,5',6-Heptachlorobiphenyl	7.3 D	µg/kg	CVS	21	%	J	None	Datum is estimated, bias unknown; CVS %D outside acceptance criterion
TS	TS-250406-1835	04/25/06	SW-846 8082	2,2',3,4,4',5,5'-Heptachlorobiphenyl	6.9 D	µg/kg	CONF	52.2	%	J	None	Datum is estimated, bias unknown; %D between primary and secondary GC columns outside acceptance criterion
TS	TS-250406-1835	04/25/06	SW-846 8082	2,2',3,4,5'-Pentachlorobiphenyl	6.7 D	µg/kg	CONF	1000	%	J	None	Datum is estimated, bias unknown; %D between primary and secondary GC columns outside acceptance criterion
TS	TS-250406-1835	04/25/06	SW-846 8082	2,2',4,4',5,5'-Hexachlorobiphenyl	17 D	µg/kg	CVS	16.3	%	J	None	Datum is estimated, bias unknown; CVS %D outside acceptance criterion
TS	TS-250406-1835	04/25/06	SW-846 8082	2,2',5,5'-Tetrachlorobiphenyl	25 D	µg/kg	CONF	152	%	J	None	Datum is estimated, bias unknown; %D between primary and secondary GC columns outside acceptance criterion
TS	TS-250406-1835	04/25/06	SW-846 8082	2,4,5-Trichlorobiphenyl	29 D	µg/kg	CONF	614	%	J	None	Datum is estimated, bias unknown; %D between primary and secondary GC columns outside acceptance criterion
TS	TS-250406-1835	04/25/06	SW-846 8082	2-Chlorobiphenyl	130 D	µg/kg	LB	0.22 T	µg/kg	B	None	Analyte detected in associated blank; sample concentration greater than five times the blank concentration
TS	TS-250406-1835	04/25/06	SW-846 8290	1,2,3,4,7,8-Hexachlorodibenzo-p-dioxin	0.45 T	pg/g	IAR	0.77	N/A	J	None	Datum is estimated, bias unknown; ion abundance ratio outside acceptance criteria
TS	TS-250406-1835	04/25/06	SW-846 8290	1,2,3,4,7,8-Hexachlorodibenzofuran	9	pg/g	PDE	N/A	N/A	J	None	Datum is estimated, bias unknown; interfering polychlorinated diphenyl ether peak present
TS	TS-250406-1835	04/25/06	SW-846 8290	1,2,3,6,7,8-Hexachlorodibenzo-p-Dioxin	3.1 T	pg/g	IAR	1	N/A	J	None	Datum is estimated, bias unknown; ion abundance ratio outside acceptance criteria
TS	TS-250406-1835	04/25/06	SW-846 8290	1,2,3,7,8,9-Hexachlorodibenzofuran	0.54 T	pg/g	LB	0.12 T	pg/g	UB	None	Analyte considered not detected, analyte detected in associated blank; sample concentration less than five times the blank concentration
TS	TS-250406-1835	04/25/06	SW-846 8290	1,2,3,7,8-Pentachlorodibenzo-p-dioxin	0.68 T	pg/g	IAR	1.23	N/A	J	None	Datum is estimated, bias unknown; ion abundance ratio outside acceptance criteria
TS	TS-250406-1835	04/25/06	SW-846 8290	1,2,3,7,8-Pentachlorodibenzofuran	1.8 T	pg/g	IAR	1.83	N/A	J	None	Datum is estimated, bias unknown; ion abundance ratio outside acceptance criteria
TS	TS-250406-1835	04/25/06	SW-846 8290	2,3,7,8-Tetrachlorodibenzofuran	3.9	pg/g	IAR	0.91	N/A	J	None	Datum is estimated, bias unknown; ion abundance ratio outside acceptance criteria

TABLE 1
DATA QUALIFIERS SUMMARY TABLE
DEMONSTRATION TESTING AND FULL-SCALE OPERATION OF THE BIOGENESIS SEDIMENT DECONTAMINATION PROCESS, KEASBEY, NEW JERSEY
(Page 166 of 188)

Location Identification	Sample Identification	Sample Date	Analysis	Analyte	Sample Result	Sample Units	QC Type	QC Result	QC Units	Qualifier	Bias	Comment
TS	TS-250406-1835	04/25/06	SW-846 8290	Octachlorodibenzo-p-dioxin	600	pg/g	LB	0.93 T	pg/g	B	None	Analyte detected in associated blank; sample concentration greater than five times the blank concentration
TS	TS-250406-1835	04/25/06	SW-846 8290	Octachlorodibenzofuran	48	pg/g	LB	0.21 T	pg/g	B	None	Analyte detected in associated blank; sample concentration greater than five times the blank concentration
TS	TS-250406-1835	04/25/06	SW-846 8081A	Dieldrin	11	µg/kg	CONF	1000	%	J	None	Datum is estimated, bias unknown; %D between primary and secondary GC columns outside acceptance criterion
TS	TS-250406-1835	04/25/06	SW-846 8081A	Alpha-Chlordane	11	µg/kg	CONF	676	%	J	None	Datum is estimated, bias unknown; %D between primary and secondary GC columns outside acceptance criterion
TS	TS-250406-1835	04/25/06	SW-846 8081A	p,p'-DDD	190	µg/kg	CONF	187	%	J	None	Datum is estimated, bias unknown; %D between primary and secondary GC columns outside acceptance criterion
TS1	TS1-250406-1820	04/25/06	SW-846 6010B	Zinc	168	mg/kg	LB	0.22 T	mg/kg	B	None	Analyte detected in associated blank; sample concentration greater than five times the blank concentration
TS2	TS2-250406-1825	04/25/06	SW-846 6010B	Zinc	143	mg/kg	LB	0.22 T	mg/kg	B	None	Analyte detected in associated blank; sample concentration greater than five times the blank concentration
TS3	TS3-250406-1830	04/25/06	SW-846 6010B	Zinc	237	mg/kg	LB	0.22 T	mg/kg	B	None	Analyte detected in associated blank; sample concentration greater than five times the blank concentration
WS	WS-250406-1840	04/25/06	SW-846 8270 SIM	Fluoranthene	600 D	µg/kg	MS	119	%	J	High	Datum is estimated, possible high bias; MS recovery outside acceptance criteria
WS	WS-250406-1840	04/25/06	SW-846 8270 SIM	Phenanthrene	340 D	µg/kg	MS	123	%	J	High	Datum is estimated, possible high bias; MS recovery outside acceptance criteria
WS	WS-250406-1840	04/25/06	SW-846 6010B	Zinc	729	mg/kg	LB	0.22 T	mg/kg	B	None	Analyte detected in associated blank; sample concentration greater than five times the blank concentration
WS	WS-250406-1840	04/25/06	SW-846 8082	2,2',3,4',5,5',6-Heptachlorobiphenyl	28 D	µg/kg	CVS	21	%	J	None	Datum is estimated, bias unknown; CVS %D outside acceptance criterion
WS	WS-250406-1840	04/25/06	SW-846 8082	2,2',3,4,4',5,5'-Heptachlorobiphenyl	28 D	µg/kg	CONF	44.4	%	J	None	Datum is estimated, bias unknown; %D between primary and secondary GC columns outside acceptance criterion
WS	WS-250406-1840	04/25/06	SW-846 8082	2,2',3,4,5'-Pentachlorobiphenyl	23 D	µg/kg	CONF	1000	%	J	None	Datum is estimated, bias unknown; %D between primary and secondary GC columns outside acceptance criterion
WS	WS-250406-1840	04/25/06	SW-846 8082	2,2',4,4',5,5'-Hexachlorobiphenyl	52 D	µg/kg	CVS	16.3	%	J	None	Datum is estimated, bias unknown; CVS %D outside acceptance criterion

TABLE 1
DATA QUALIFIERS SUMMARY TABLE
DEMONSTRATION TESTING AND FULL-SCALE OPERATION OF THE BIOGENESIS SEDIMENT DECONTAMINATION PROCESS, KEASBEY, NEW JERSEY
(Page167 of 188)

Location Identification	Sample Identification	Sample Date	Analysis	Analyte	Sample Result	Sample Units	QC Type	QC Result	QC Units	Qualifier	Bias	Comment
WS	WS-250406-1840	04/25/06	SW-846 8082	2,2',5,5'-Tetrachlorobiphenyl	89 D	µg/kg	CONF	145	%	J	None	Datum is estimated, bias unknown; %D between primary and secondary GC columns outside acceptance criterion
WS	WS-250406-1840	04/25/06	SW-846 8082	2,3-Dichlorobiphenyl	7 8 D	µg/kg	CONF	96 9	%	J	None	Datum is estimated, bias unknown; %D between primary and secondary GC columns outside acceptance criterion
WS	WS-250406-1840	04/25/06	SW-846 8082	2,4,5-Trichlorobiphenyl	100 D	µg/kg	CONF	585	%	J	None	Datum is estimated, bias unknown; %D between primary and secondary GC columns outside acceptance criterion
WS	WS-250406-1840	04/25/06	SW-846 8082	2-Chlorobiphenyl	170 D	µg/kg	CONF LB	46 2 0 22 T	% µg/kg	JB	None	Datum is estimated, bias unknown; %D between primary and secondary GC columns outside acceptance criterion Analyte detected in associated blank; sample concentration greater than five times the blank concentration
WS	WS-250406-1840	04/25/06	SW-846 8270C	Benzo(a)anthracene	63 T	µg/kg	MS MSD	124 121	%	J	High	Datum is estimated, possible high bias; MS/MSD recoveries outside acceptance criteria
WS	WS-250406-1840	04/25/06	SW-846 8270C	Chrysene	77 T	µg/kg	MS MSD	121 122	%	J	High	Datum is estimated, possible high bias; MS/MSD recoveries outside acceptance criteria
WS	WS-250406-1840	04/25/06	SW-846 8270C	Fluoranthene	150 T	µg/kg	MS MSD	155 130	%	J	High	Datum is estimated, possible high bias; MS/MSD recoveries outside acceptance criteria
WS	WS-250406-1840	04/25/06	SW-846 8270C	Pyrene	200 T	µg/kg	MS MSD	139 136	%	J	High	Datum is estimated, possible high bias; MS/MSD recoveries outside acceptance criteria
WS	WS-250406-1840	04/25/06	SW-846 8290	1,2,3,4,7,8-Hexachlorodibenzofuran	26	pg/g	PDE	N/A	N/A	J	None	Datum is estimated, bias unknown; interfering polychlorinated diphenyl ether peak present
WS	WS-250406-1840	04/25/06	SW-846 8290	1,2,3,7,8,9-Hexachlorodibenzofuran	1 1 T	pg/g	IAR LB	1 85 0 12 T	N/A pg/g	JB	None	Datum is estimated, bias unknown; ion abundance ratio outside acceptance criteria Analyte detected in associated blank; sample concentration greater than five times the blank concentration
WS	WS-250406-1840	04/25/06	SW-846 8290	1,2,3,7,8-Pentachlorodibenzo-p-dioxin	1 7 T	pg/g	IAR	1 23	N/A	J	None	Datum is estimated, bias unknown; ion abundance ratio outside acceptance criteria
WS	WS-250406-1840	04/25/06	SW-846 8290	1,2,3,7,8-Pentachlorodibenzofuran	4 7 T	pg/g	IAR	1 29	N/A	J	None	Datum is estimated, bias unknown; ion abundance ratio outside acceptance criteria
WS	WS-250406-1840	04/25/06	SW-846 8290	Octachlorodibenzo-p-dioxin	1800	pg/g	LB	0 93 T	pg/g	B	None	Analyte detected in associated blank; sample concentration greater than five times the blank concentration
WS	WS-250406-1840	04/25/06	SW-846 8290	Octachlorodibenzofuran	130	pg/g	LB	0 21 T	pg/g	B	None	Analyte detected in associated blank; sample concentration greater than five times the blank concentration
WS	WS-250406-1840	04/25/06	SW-846 8081A	beta Endosulfan	32	µg/kg	CONF	204	%	J	None	Datum is estimated, bias unknown; %D between primary and secondary GC columns outside acceptance criterion
WS	WS-250406-1840	04/25/06	SW-846 8081A	Endrin	36	µg/kg	CONF	64 1	%	J	None	Datum is estimated, bias unknown; %D between primary and secondary GC columns outside acceptance criterion
WS	WS-250406-1840	04/25/06	SW-846 8081A	Alpha-Chlordane	22	µg/kg	CONF	874	%	J	None	Datum is estimated, bias unknown; %D between primary and secondary GC columns outside acceptance criterion

TABLE 1
DATA QUALIFIERS SUMMARY TABLE
DEMONSTRATION TESTING AND FULL-SCALE OPERATION OF THE BIOGENESIS SEDIMENT DECONTAMINATION PROCESS, KEASBEY, NEW JERSEY
(Page 168 of 188)

Location Identification	Sample Identification	Sample Date	Analysis	Analyte	Sample Result	Sample Units	QC Type	QC Result	QC Units	Qualifier	Bias	Comment
WS	WS-250406-1840	04/25/06	SW-846 8081A	p,p'-DDD	240	µg/kg	CONF	378	%	J	None	Datum is estimated, bias unknown; %D between primary and secondary GC columns outside acceptance criterion
WS	WS-250406-1840	04/25/06	SW-846 8081A	p,p'-DDT	140	µg/kg	CONF	134	%	J	None	Datum is estimated, bias unknown; %D between primary and secondary GC columns outside acceptance criterion
PSS	PSS-260406-1300	04/26/06	SW-846 6010B	Lead	220	mg/kg	MS MSD SLD	127 129 10.8	%	J	High	Datum is estimated, possible high bias; MS/MSD recoveries and serial dilution %D outside acceptance criteria
PSS	PSS-260406-1300	04/26/06	SW-846 6010B	Nickel	42.7	mg/kg	SLD	11	%	J	None	Datum is estimated, bias unknown; serial dilution %D outside acceptance criterion
PSS	PSS-260406-1300	04/26/06	SW-846 6010B	Selenium	1.7	mg/kg	SLD	76.8	%	J	None	Datum is estimated, bias unknown; serial dilution %D outside acceptance criterion
PSS	PSS-260406-1300	04/26/06	SW-846 6010B	Zinc	371	mg/kg	SLD	13.1	%	J	None	Datum is estimated, bias unknown; serial dilution %D outside acceptance criterion
TS1	TS1-260406-1320	04/26/06	SW-846 8270 SIM	Benzo(a)anthracene	3500 D	µg/kg	MS MSD	30 38	%	J	Low	Datum is estimated, possible low bias; MS/MSD recoveries outside acceptance criteria
TS1	TS1-260406-1320	04/26/06	SW-846 8270 SIM	Benzo(a)pyrene	3400 D	µg/kg	MS MSD	19 26	%	J	Low	Datum is estimated, possible low bias; MS/MSD recoveries outside acceptance criteria
TS1	TS1-260406-1320	04/26/06	SW-846 8270 SIM	Benzo(b)fluoranthene	3500 D	µg/kg	MS MSD	25 15	%	J	Low	Datum is estimated, possible low bias; MS/MSD recoveries outside acceptance criteria
TS1	TS1-260406-1320	04/26/06	SW-846 8270 SIM	Benzo(k)fluoranthene	1600 D	µg/kg	MS	23	%	J	Low	Datum is estimated, possible low bias; MS recovery outside acceptance criteria
TS1	TS1-260406-1320	04/26/06	SW-846 8270 SIM	Chrysene	3600 D	µg/kg	MS MSD	19 11	%	J	Low	Datum is estimated, possible low bias; MS/MSD recoveries outside acceptance criteria
TS1	TS1-260406-1320	04/26/06	SW-846 8270 SIM	Indeno(1,2,3-c,d)pyrene	2000 D	µg/kg	MS	39	%	J	Low	Datum is estimated, possible low bias; MS recovery outside acceptance criteria
TS1	TS1-260406-1320	04/26/06	SW-846 8270 SIM	Phenanthrene	4000 D	µg/kg	MS MSD	12 13 2006	%	J	Low	Datum is estimated, possible low bias; MS/MSD recoveries outside acceptance criteria
PSS	PSS-270406-1700	04/27/06	SW-846 6010B	Barium	385	mg/kg	MS	73	%	J	Low	Datum is estimated, possible low bias; MS recovery outside acceptance criteria
PSS	PSS-270406-1700	04/27/06	SW-846 6010B	Lead	287	mg/kg	MS	66	%	J	Low	Datum is estimated, possible low bias; MS recovery outside acceptance criteria
PSS	PSS-270406-1700	04/27/06	SW-846 6010B	Selenium	2.4	mg/kg	SLD	35.2	%	J	None	Datum is estimated, bias unknown; serial dilution %D outside acceptance criterion
PSS	PSS-270406-1700	04/27/06	SW-846 6010B	Zinc	476	mg/kg	SLD	10.8	%	J	None	Datum is estimated, bias unknown; serial dilution %D outside acceptance criterion
RS	RS-270406-1715	04/27/06	SW-846 8082	2,2',3,4',5,5',6-Heptachlorobiphenyl	13 D	µg/kg	CVS	21	%	J	None	Datum is estimated, bias unknown; CVS %D outside acceptance criterion

TABLE 1
DATA QUALIFIERS SUMMARY TABLE
DEMONSTRATION TESTING AND FULL-SCALE OPERATION OF THE BIOGENESIS SEDIMENT DECONTAMINATION PROCESS, KEASBEY, NEW JERSEY
(Page 169 of 188)

Location Identification	Sample Identification	Sample Date	Analysis	Analyte	Sample Result	Sample Units	QC Type	QC Result	QC Units	Qualifier	Bias	Comment
RS	RS-270406-1715	04/27/06	SW-846 8082	2,2',3,4,4',5,5'-Heptachlorobiphenyl	13 D	µg/kg	CONF	62.2	%	J	None	Datum is estimated, bias unknown; %D between primary and secondary GC columns outside acceptance criterion
RS	RS-270406-1715	04/27/06	SW-846 8082	2,2',3,4,5'-Pentachlorobiphenyl	12 D	µg/kg	CONF	1000	%	J	None	Datum is estimated, bias unknown; %D between primary and secondary GC columns outside acceptance criterion
RS	RS-270406-1715	04/27/06	SW-846 8082	2,2',4,4',5,5'-Hexachlorobiphenyl	24 D	µg/kg	CVS	16.3	%	J	None	Datum is estimated, bias unknown; CVS %D outside acceptance criterion
RS	RS-270406-1715	04/27/06	SW-846 8082	2,2',5,5'-Tetrachlorobiphenyl	42 D	µg/kg	CONF	61.9	%	J	None	Datum is estimated, bias unknown; %D between primary and secondary GC columns outside acceptance criterion
RS	RS-270406-1715	04/27/06	SW-846 8082	2,4,5-Trichlorobiphenyl	47 D	µg/kg	CONF	370	%	J	None	Datum is estimated, bias unknown; %D between primary and secondary GC columns outside acceptance criterion
RS	RS-270406-1715	04/27/06	SW-846 8082	2-Chlorobiphenyl	99 D	µg/kg	CONF LB	53.1 0.17 T	% µg/kg	JB	None	Datum is estimated, bias unknown; %D between primary and secondary GC columns outside acceptance criterion Analyte detected in associated blank; sample concentration greater than five times the blank concentration
RS	RS-270406-1715	04/27/06	SW-846 8290	1,2,3,4,7,8-Hexachlorodibenzofuran	93	pg/g	PDE	N/A	N/A	J	None	Datum is estimated, bias unknown; interfering polychlorinated diphenyl ether peak present
RS	RS-270406-1715	04/27/06	SW-846 8290	1,2,3,7,8,9-Hexachlorodibenzofuran	1.7 T	pg/g	IAR LB	0.99 0.12 T	N/A pg/g	JB	None	Datum is estimated, bias unknown; ion abundance ratio outside acceptance criteria Analyte detected in associated blank; sample concentration greater than five times the blank concentration
RS	RS-270406-1715	04/27/06	SW-846 8290	1,2,3,7,8-Pentachlorodibenzo-p-dioxin	5.1 T	pg/g	IAR	1.08	N/A	J	None	Datum is estimated, bias unknown; ion abundance ratio outside acceptance criteria
RS	RS-270406-1715	04/27/06	SW-846 8290	Octachlorodibenzo-p-dioxin	6700	pg/g	LB	0.93 T	pg/g	B	None	Analyte detected in associated blank; sample concentration greater than five times the blank concentration
RS	RS-270406-1715	04/27/06	SW-846 8290	Octachlorodibenzofuran	520	pg/g	LB	0.21 T	pg/g	B	None	Analyte detected in associated blank; sample concentration greater than five times the blank concentration
RS	RS-270406-1715	04/27/06	SW-846 8081A	p,p'-DDD	150	µg/kg	CONF	244	%	J	None	Datum is estimated, bias unknown; %D between primary and secondary GC columns outside acceptance criterion
RS	RS-270406-1715	04/27/06	SW-846 8081A	p,p'-DDT	170	µg/kg	CONF	68.4	%	J	None	Datum is estimated, bias unknown; %D between primary and secondary GC columns outside acceptance criterion
TS	TS-270406-1735	04/27/06	SW-846 8082	2,2',3,4',5,5',6-Heptachlorobiphenyl	11 D	µg/kg	CVS	21	%	J	None	Datum is estimated, bias unknown; CVS %D outside acceptance criterion
TS	TS-270406-1735	04/27/06	SW-846 8082	2,2',3,4,4',5,5'-Heptachlorobiphenyl	9.4 D	µg/kg	CONF	56.7	%	J	None	Datum is estimated, bias unknown; %D between primary and secondary GC columns outside acceptance criterion
TS	TS-270406-1735	04/27/06	SW-846 8082	2,2',3,4,5'-Pentachlorobiphenyl	8.4 D	µg/kg	CONF	1000	%	J	None	Datum is estimated, bias unknown; %D between primary and secondary GC columns outside acceptance criterion

TABLE 1
DATA QUALIFIERS SUMMARY TABLE
DEMONSTRATION TESTING AND FULL-SCALE OPERATION OF THE BIOGENESIS SEDIMENT DECONTAMINATION PROCESS, KEASBEY, NEW JERSEY
(Page170 of 188)

Location Identification	Sample Identification	Sample Date	Analysis	Analyte	Sample Result	Sample Units	QC Type	QC Result	QC Units	Qualifier	Bias	Comment
TS	TS-270406-1735	04/27/06	SW-846 8082	2,2',4,4',5,5'-Hexachlorobiphenyl	21 D	µg/kg	CVS	16.3	%	J	None	Datum is estimated, bias unknown; CVS %D outside acceptance criterion
TS	TS-270406-1735	04/27/06	SW-846 8082	2,2',4,5,5'-Pentachlorobiphenyl	21 D	µg/kg	CONF	45.8	%	J	None	Datum is estimated, bias unknown; %D between primary and secondary GC columns outside acceptance criterion
TS	TS-270406-1735	04/27/06	SW-846 8082	2,2',5,5'-Tetrachlorobiphenyl	31 D	µg/kg	CONF	110	%	J	None	Datum is estimated, bias unknown; %D between primary and secondary GC columns outside acceptance criterion
TS	TS-270406-1735	04/27/06	SW-846 8082	2,4,5-Trichlorobiphenyl	40 D	µg/kg	CONF	119	%	J	None	Datum is estimated, bias unknown; %D between primary and secondary GC columns outside acceptance criterion
TS	TS-270406-1735	04/27/06	SW-846 8082	2-Chlorobiphenyl	86 D	µg/kg	CONF LB	110 0.17 T	% µg/kg	JB	None	Datum is estimated, bias unknown; %D between primary and secondary GC columns outside acceptance criterion Analyte detected in associated blank; sample concentration greater than five times the blank concentration
TS	TS-270406-1735	04/27/06	SW-846 8290	1,2,3,4,7,8-Hexachlorodibenzo-p-dioxin	0.51 T	pg/g	IAR	1.82	N/A	J	None	Datum is estimated, bias unknown; ion abundance ratio outside acceptance criteria
TS	TS-270406-1735	04/27/06	SW-846 8290	1,2,3,4,7,8-Hexachlorodibenzofuran	9.9	pg/g	PDE	N/A	N/A	J	None	Datum is estimated, bias unknown; interfering polychlorinated diphenyl ether peak present
TS	TS-270406-1735	04/27/06	SW-846 8290	1,2,3,6,7,8-Hexachlorodibenzofuran	2.8 T	pg/g	IAR	1.49	N/A	J	None	Datum is estimated, bias unknown; ion abundance ratio outside acceptance criteria
TS	TS-270406-1735	04/27/06	SW-846 8290	Octachlorodibenzo-p-dioxin	1100	pg/g	LB	0.93 T	pg/g	B	None	Analyte detected in associated blank; sample concentration greater than five times the blank concentration
TS	TS-270406-1735	04/27/06	SW-846 8290	Octachlorodibenzofuran	64	pg/g	LB	0.21 T	pg/g	B	None	Analyte detected in associated blank; sample concentration greater than five times the blank concentration
TS	TS-270406-1735	04/27/06	SW-846 8081A	Dieldrin	14	µg/kg	CONF	1000	%	J	None	Datum is estimated, bias unknown; %D between primary and secondary GC columns outside acceptance criterion
TS	TS-270406-1735	04/27/06	SW-846 8081A	Endrin aldehyde	15	µg/kg	CONF	1000	%	J	None	Datum is estimated, bias unknown; %D between primary and secondary GC columns outside acceptance criterion
TS	TS-270406-1735	04/27/06	SW-846 8081A	p,p'-DDD	210	µg/kg	CONF	154	%	J	None	Datum is estimated, bias unknown; %D between primary and secondary GC columns outside acceptance criterion
WS	WS-270406-1740	04/27/06	SW-846 8082	2,2',3,4',5,5',6-Heptachlorobiphenyl	34 D	µg/kg	CVS	21	%	J	None	Datum is estimated, bias unknown; CVS %D outside acceptance criterion
WS	WS-270406-1740	04/27/06	SW-846 8082	2,2',3,4,4',5,5'-Heptachlorobiphenyl	32 D	µg/kg	CONF	47.1	%	J	None	Datum is estimated, bias unknown; %D between primary and secondary GC columns outside acceptance criterion
WS	WS-270406-1740	04/27/06	SW-846 8082	2,2',3,4,5'-Pentachlorobiphenyl	30 D	µg/kg	CONF	1000	%	J	None	Datum is estimated, bias unknown; %D between primary and secondary GC columns outside acceptance criterion

TABLE 1
DATA QUALIFIERS SUMMARY TABLE
DEMONSTRATION TESTING AND FULL-SCALE OPERATION OF THE BIOGENESIS SEDIMENT DECONTAMINATION PROCESS, KEASBEY, NEW JERSEY
(Page 171 of 188)

Location Identification	Sample Identification	Sample Date	Analysis	Analyte	Sample Result	Sample Units	QC Type	QC Result	QC Units	Qualifier	Bias	Comment
WS	WS-270406-1740	04/27/06	SW-846 8082	2,2',4,4',5,5'-Hexachlorobiphenyl	60 D	µg/kg	CVS	16 3	%	J	None	Datum is estimated, bias unknown; CVS %D outside acceptance criterion
WS	WS-270406-1740	04/27/06	SW-846 8082	2,2',5,5'-Tetrachlorobiphenyl	110 D	µg/kg	CONF	97 3	%	J	None	Datum is estimated, bias unknown; %D between primary and secondary GC columns outside acceptance criterion
WS	WS-270406-1740	04/27/06	SW-846 8082	2,4,5-Trichlorobiphenyl	120 D	µg/kg	CONF	85 1	%	J	None	Datum is estimated, bias unknown; %D between primary and secondary GC columns outside acceptance criterion
WS	WS-270406-1740	04/27/06	SW-846 8082	2-Chlorobiphenyl	140 D	µg/kg	CONF LB	54 8 0 17 T	% µg/kg	JB	None	Datum is estimated, bias unknown; %D between primary and secondary GC columns outside acceptance criterion Analyte detected in associated blank; sample concentration greater than five times the blank concentration
WS	WS-270406-1740	04/27/06	SW-846 8270C	Benzo(g,h,i)perylene	260 TD	µg/kg	MSD	46	%	J	Low	Datum is estimated, possible low bias; MSD recovery outside acceptance criteria
WS	WS-270406-1740	04/27/06	SW-846 8270C	Hexachloroethane	<3300 D	µg/kg	MS MSD	33 26	%	UJ	Low	Possible false negative; MS/MSD recoveries outside acceptance criteria
WS	WS-270406-1740	04/27/06	SW-846 8290	1,2,3,4,7,8-Hexachlorodibenzofuran	83	pg/g	PDE	N/A	N/A	J	None	Datum is estimated, bias unknown; interfering polychlorinated diphenyl ether peak present
WS	WS-270406-1740	04/27/06	SW-846 8290	1,2,3,7,8-Pentachlorodibenzo-p-dioxin	5 7 T	pg/g	IAR	1 26	N/A	J	None	Datum is estimated, bias unknown; ion abundance ratio outside acceptance criteria
WS	WS-270406-1740	04/27/06	SW-846 8290	Octachlorodibenzo-p-dioxin	6600	pg/g	LB	0 93 T	pg/g	B	None	Analyte detected in associated blank; sample concentration greater than five times the blank concentration
WS	WS-270406-1740	04/27/06	SW-846 8290	Octachlorodibenzofuran	500	pg/g	LB	0 21 T	pg/g	B	None	Analyte detected in associated blank; sample concentration greater than five times the blank concentration
WS	WS-270406-1740	04/27/06	SW-846 8081A	Endrin	48	µg/kg	CONF	42 2	%	J	None	Datum is estimated, bias unknown; %D between primary and secondary GC columns outside acceptance criterion
WS	WS-270406-1740	04/27/06	SW-846 8081A	Endrin aldehyde	52	µg/kg	CONF	1000	%	J	None	Datum is estimated, bias unknown; %D between primary and secondary GC columns outside acceptance criterion
WS	WS-270406-1740	04/27/06	SW-846 8081A	p,p'-DDD	340	µg/kg	CONF	310	%	J	None	Datum is estimated, bias unknown; %D between primary and secondary GC columns outside acceptance criterion
WS	WS-270406-1740	04/27/06	SW-846 8081A	p,p'-DDT	250	µg/kg	CONF	139	%	J	None	Datum is estimated, bias unknown; %D between primary and secondary GC columns outside acceptance criterion
PSS	PSS-280406-1100	04/28/06	SW-846 6010B	Lead	317	mg/kg	MSD	65	%	J	Low	Datum is estimated, possible low bias; MSD recovery outside acceptance criteria
PSS	PSS-280406-1100	04/28/06	SW-846 6010B	Selenium	2 3	mg/kg	SLD	100	%	J	None	Datum is estimated, bias unknown; serial dilution %D outside acceptance criterion

TABLE 1
DATA QUALIFIERS SUMMARY TABLE
DEMONSTRATION TESTING AND FULL-SCALE OPERATION OF THE BIOGENESIS SEDIMENT DECONTAMINATION PROCESS, KEASBEY, NEW JERSEY
(Page 172 of 188)

Location Identification	Sample Identification	Sample Date	Analysis	Analyte	Sample Result	Sample Units	QC Type	QC Result	QC Units	Qualifier	Bias	Comment
PSS	PSS-280406-1100	04/28/06	SW-846 6010B	Zinc	473	mg/kg	SLD	11.3	%	J	None	Datum is estimated, bias unknown; serial dilution %D outside acceptance criterion
TS1	TS1-280406-1120	04/28/06	SW-846 8270 SIM	Benzo(a)anthracene	3900 D	µg/kg	MS MSD	28 0	%	J	Low	Datum is estimated, possible low bias; MS/MSD recoveries outside acceptance criteria
PSS	PSS-010506-1600	05/01/06	Lloyd Kahn	Total organic carbon	74100	mg/kg	CVS	110	%	J	High	Datum is estimated, bias unknown; CVS %D outside acceptance criterion
PSS	PSS-010506-1600	05/01/06	SW-846 6010B	Arsenic	15.4	mg/kg	SLD	10.9	%	J	None	Datum is estimated, bias unknown; serial dilution %D outside acceptance criterion
PSS	PSS-010506-1600	05/01/06	SW-846 6010B	Cadmium	7.7	mg/kg	MS	74	%	J	Low	Datum is estimated, possible low bias; MS recovery outside acceptance criteria
PSS	PSS-010506-1600	05/01/06	SW-846 6010B	Chromium, total	256	mg/kg	SLD	10.5	%	J	None	Datum is estimated, bias unknown; serial dilution %D outside acceptance criterion
PSS	PSS-010506-1600	05/01/06	SW-846 6010B	Lead	521	mg/kg	SLD	12	%	J	None	Datum is estimated, bias unknown; serial dilution %D outside acceptance criterion
PSS	PSS-010506-1600	05/01/06	SW-846 6010B	Nickel	70	mg/kg	SLD	10.3	%	J	None	Datum is estimated, bias unknown; serial dilution %D outside acceptance criterion
PSS	PSS-010506-1600	05/01/06	SW-846 6010B	Selenium	3.9	mg/kg	SLD	100	%	J	None	Datum is estimated, bias unknown; serial dilution %D outside acceptance criterion
PSS	PSS-010506-1600	05/01/06	SW-846 6010B	Silver	9.3	mg/kg	MS MSD SLD	74 71 11.2	%	J	Low	Datum is estimated, possible low bias; MS/MSD recoveries and serial dilution %D outside acceptance criteria
PSS	PSS-010506-1600	05/01/06	SW-846 6010B	Zinc	935	mg/kg	SLD LB	14.5 0.24 T	% mg/kg	JB	None	Datum is estimated, bias unknown; serial dilution percent difference outside acceptance criterion. Analyte detected in associated blank; sample concentration greater than five times the blank concentration
PSS	PSS-010506-1600	05/01/06	SW-846 8082	2,2',3,4,4',5,5'-Heptachlorobiphenyl	21 D	µg/kg	CONF	48.6	%	J	None	Datum is estimated, bias unknown; %D between primary and secondary GC columns outside acceptance criterion
PSS	PSS-010506-1600	05/01/06	SW-846 8082	2,2',3,4,5'-Pentachlorobiphenyl	12 D	µg/kg	CONF	576	%	J	None	Datum is estimated, bias unknown; %D between primary and secondary GC columns outside acceptance criterion
PSS	PSS-010506-1600	05/01/06	SW-846 8082	2,3-Dichlorobiphenyl	1.4 TD	µg/kg	CONF	583	%	J	None	Datum is estimated, bias unknown; %D between primary and secondary GC columns outside acceptance criterion
PSS	PSS-010506-1600	05/01/06	SW-846 8082	2-Chlorobiphenyl	52 TD	µg/kg	CONF LB	106 0.15 T	% µg/kg	JB	None	Datum is estimated, bias unknown; %D between primary and secondary GC columns outside acceptance criterion. Analyte detected in associated blank; sample concentration greater than five times the blank concentration
PSS	PSS-010506-1600	05/01/06	SW-846 8290	1,2,3,4,6,7,8-Heptachlorodibenzofuran	1100	pg/g	PDE	N/A	N/A	J	None	Datum is estimated, bias unknown; interfering polychlorinated diphenyl ether peak present
PSS	PSS-010506-1600	05/01/06	SW-846 8290	1,2,3,4,7,8,9-Heptachlorodibenzofuran	38	pg/g	PDE	N/A	N/A	J	None	Datum is estimated, bias unknown; interfering polychlorinated diphenyl ether peak present

TABLE 1
DATA QUALIFIERS SUMMARY TABLE
DEMONSTRATION TESTING AND FULL-SCALE OPERATION OF THE BIOGENESIS SEDIMENT DECONTAMINATION PROCESS, KEASBEY, NEW JERSEY
(Page 173 of 188)

Location Identification	Sample Identification	Sample Date	Analysis	Analyte	Sample Result	Sample Units	QC Type	QC Result	QC Units	Qualifier	Bias	Comment
PSS	PSS-010506-1600	05/01/06	SW-846 8290	1,2,3,4,7,8-Hexachlorodibenzofuran	260	pg/g	PDE	N/A	N/A	J	None	Datum is estimated, bias unknown; interfering polychlorinated diphenyl ether peak present
PSS	PSS-010506-1600	05/01/06	SW-846 8290	1,2,3,7,8,9-Hexachlorodibenzofuran	34	pg/g	PDE	N/A	N/A	J	None	Datum is estimated, bias unknown; interfering polychlorinated diphenyl ether peak present
PSS	PSS-010506-1600	05/01/06	SW-846 8290	1,2,3,7,8-Pentachlorodibenzofuran	27 T	pg/g	PDE	N/A	N/A	J	None	Datum is estimated, bias unknown; interfering polychlorinated diphenyl ether peak present
PSS	PSS-010506-1600	05/01/06	SW-846 8290	2,3,7,8-Tetrachlorodibenzofuran	38	pg/g	CMC	3	s	J	None	Datum is estimated, bias unknown; peaks comax outside acceptance criterion
PSS	PSS-010506-1600	05/01/06	SW-846 8290	Octachlorodibenzo-p-Dioxin	9500	pg/g	LB	0 41 T	pg/g	B	None	Analyte detected in associated blank; sample concentration greater than five times the blank concentration
PSS	PSS-010506-1600	05/01/06	SW-846 8290	Octachlorodibenzofuran	1300	pg/g	PDE	N/A	N/A	J	None	Datum is estimated, bias unknown; interfering polychlorinated diphenyl ether peak present
PSS	PSS-010506-1600	05/01/06	SW-846 8081A	Endrin	42	µg/kg	CONF	69 1	%	J	None	Datum is estimated, bias unknown; %D between primary and secondary GC columns outside acceptance criterion
PSS	PSS-010506-1600	05/01/06	SW-846 8081A	p,p'-DDD	30	µg/kg	CONF	841	%	J	None	Datum is estimated, bias unknown; %D between primary and secondary GC columns outside acceptance criterion
RS	RS-010506-1615	05/01/06	Lloyd Kahn	Total organic carbon	56500	mg/kg	CVS	117	%	J	High	Datum is estimated, bias unknown; CVS %D outside acceptance criterion
RS	RS-010506-1615	05/01/06	SW-846 6010B	Zinc	763	mg/kg	LB	0 24 T	mg/kg	B	None	Analyte detected in associated blank; sample concentration greater than five times the blank concentration
RS	RS-010506-1615	05/01/06	SW-846 8082	2,2',3,4,4',5,5'-Heptachlorobiphenyl	16 D	µg/kg	CONF	47 8	%	J	None	Datum is estimated, bias unknown; %D between primary and secondary GC columns outside acceptance criterion
RS	RS-010506-1615	05/01/06	SW-846 8082	2,2',3,4,5'-Pentachlorobiphenyl	12 D	µg/kg	CONF	489	%	J	None	Datum is estimated, bias unknown; %D between primary and secondary GC columns outside acceptance criterion
RS	RS-010506-1615	05/01/06	SW-846 8082	2,3-Dichlorobiphenyl	1 4 TD	µg/kg	CONF	495	%	J	None	Datum is estimated, bias unknown; %D between primary and secondary GC columns outside acceptance criterion
RS	RS-010506-1615	05/01/06	SW-846 8082	2-Chlorobiphenyl	61 TD	µg/kg	LB	0 17 T	µg/kg	B	None	Analyte detected in associated blank; sample concentration greater than five times the blank concentration
RS	RS-010506-1615	05/01/06	SW-846 8290	1,2,3,4,7,8,9-Heptachlorodibenzofuran	39	pg/g	PDE	N/A	N/A	J	None	Datum is estimated, bias unknown; interfering polychlorinated diphenyl ether peak present
RS	RS-010506-1615	05/01/06	SW-846 8290	1,2,3,6,7,8-Hexachlorodibenzofuran	91	pg/g	PDE	N/A	N/A	J	None	Datum is estimated, bias unknown; interfering polychlorinated diphenyl ether peak present
RS	RS-010506-1615	05/01/06	SW-846 8290	1,2,3,7,8,9-Hexachlorodibenzo-p-Dioxin	45	pg/g	IAR	0 76	N/A	J	None	Datum is estimated, bias unknown; ion abundance ratio outside acceptance criteria
RS	RS-010506-1615	05/01/06	SW-846 8290	1,2,3,7,8,9-Hexachlorodibenzofuran	1 1 T	pg/g	IAR	0 51	N/A	J	None	Datum is estimated, bias unknown; ion abundance ratio outside acceptance criteria

TABLE 1
DATA QUALIFIERS SUMMARY TABLE
DEMONSTRATION TESTING AND FULL-SCALE OPERATION OF THE BIOGENESIS SEDIMENT DECONTAMINATION PROCESS, KEASBEY, NEW JERSEY
(Page 174 of 188)

Location Identification	Sample Identification	Sample Date	Analysis	Analyte	Sample Result	Sample Units	QC Type	QC Result	QC Units	Qualifier	Bias	Comment
RS	RS-010506-1615	05/01/06	SW-846 8290	1,2,3,7,8-Pentachlorodibenzo-p-dioxin	13 T	pg/g	IAR	0 12	N/A	J	None	Datum is estimated, bias unknown; ion abundance ratio outside acceptance criteria
RS	RS-010506-1615	05/01/06	SW-846 8290	1,2,3,7,8-Pentachlorodibenzofuran	24	pg/g	PDE	N/A	N/A	J	None	Datum is estimated, bias unknown; interfering polychlorinated diphenyl ether peak present
RS	RS-010506-1615	05/01/06	SW-846 8290	2,3,4,7,8-Pentachlorodibenzofuran	68	pg/g	PDE	N/A	N/A	J	None	Datum is estimated, bias unknown; interfering polychlorinated diphenyl ether peak present
RS	RS-010506-1615	05/01/06	SW-846 8290	Octachlorodibenzo-p-dioxin	10000	pg/g	LB	0 41 T	pg/g	B	None	Analyte detected in associated blank; sample concentration greater than five times the blank concentration
RS	RS-010506-1615	05/01/06	SW-846 8290	Octachlorodibenzofuran	1300	pg/g	PDE	N/A	N/A	J	None	Datum is estimated, bias unknown; interfering polychlorinated diphenyl ether peak present
RS	RS-010506-1615	05/01/06	SW-846 8081A	p,p'-DDD	45	µg/kg	CONF	434	%	J	None	Datum is estimated, bias unknown; %D between primary and secondary GC columns outside acceptance criterion
RS	RS-010506-1615	05/01/06	SW-846 8081A	p,p'-DDT	44	µg/kg	CONF	124	%	J	None	Datum is estimated, bias unknown; %D between primary and secondary GC columns outside acceptance criterion
SS1	SS1-010506-1605	05/01/06	Lloyd Kahn	Total organic carbon	283000	mg/kg	CVS	110	%	J	High	Datum is estimated, bias unknown; CVS %D outside acceptance criterion
SS1	SS1-010506-1605	05/01/06	SW-846 6010B	Zinc	683	mg/kg	LB	0 24 T	mg/kg	B	None	Analyte detected in associated blank; sample concentration greater than five times the blank concentration
SS2	SS2-010506-1610	05/01/06	Lloyd Kahn	Total organic carbon	346000	mg/kg	CVS	117	%	J	High	Datum is estimated, bias unknown; CVS %D outside acceptance criterion
SS2	SS2-010506-1610	05/01/06	SW-846 6010B	Zinc	659	mg/kg	LB	0 24 T	mg/kg	B	None	Analyte detected in associated blank; sample concentration greater than five times the blank concentration
TS	TS-010506-1635	05/01/06	Lloyd Kahn	Total organic carbon	43900	mg/kg	CVS	117	%	J	High	Datum is estimated, bias unknown; CVS %D outside acceptance criterion
TS	TS-010506-1635	05/01/06	SW-846 6010B	Zinc	349	mg/kg	LB	0 24 T	mg/kg	B	None	Analyte detected in associated blank; sample concentration greater than five times the blank concentration
TS	TS-010506-1635	05/01/06	SW-846 8082	2,2',3,4,5'-Pentachlorobiphenyl	12 D	µg/kg	CONF	1000	%	J	None	Datum is estimated, bias unknown; %D between primary and secondary GC columns outside acceptance criterion
TS	TS-010506-1635	05/01/06	SW-846 8082	2,3-Dichlorobiphenyl	2 TD	µg/kg	CONF	379	%	J	None	Datum is estimated, bias unknown; %D between primary and secondary GC columns outside acceptance criterion
TS	TS-010506-1635	05/01/06	SW-846 8082	2-Chlorobiphenyl	4 9 TD	µg/kg	CONF LB	1000 0 17 T	% µg/kg	JB	None	Datum is estimated, bias unknown; %D between primary and secondary GC columns outside acceptance criterion Analyte detected in associated blank; sample concentration greater than five times the blank concentration
TS	TS-010506-1635	05/01/06	SW-846 8290	1,2,3,4,7,8,9-Heptachlorodibenzofuran	6 3 T	pg/g	PDE	N/A	N/A	J	None	Datum is estimated, bias unknown; interfering polychlorinated diphenyl ether peak present

TABLE 1
DATA QUALIFIERS SUMMARY TABLE
DEMONSTRATION TESTING AND FULL-SCALE OPERATION OF THE BIOGENESIS SEDIMENT DECONTAMINATION PROCESS, KEASBEY, NEW JERSEY
(Page 175 of 188)

Location Identification	Sample Identification	Sample Date	Analysis	Analyte	Sample Result	Sample Units	QC Type	QC Result	QC Units	Qualifier	Bias	Comment
TS	TS-010506-1635	05/01/06	SW-846 8290	1,2,3,4,7,8-Hexachlorodibenzo-p-dioxin	1.6 T	pg/g	IAR	1.5	N/A	J	None	Datum is estimated, bias unknown; ion abundance ratio outside acceptance criteria
TS	TS-010506-1635	05/01/06	SW-846 8290	1,2,3,4,7,8-Hexachlorodibenzofuran	30	pg/g	PDE	N/A	N/A	J	None	Datum is estimated, bias unknown; interfering polychlorinated diphenyl ether peak present
TS	TS-010506-1635	05/01/06	SW-846 8290	1,2,3,6,7,8-Hexachlorodibenzofuran	9.3	pg/g	PDE	N/A	N/A	J	None	Datum is estimated, bias unknown; interfering polychlorinated diphenyl ether peak present
TS	TS-010506-1635	05/01/06	SW-846 8290	1,2,3,7,8,9-Hexachlorodibenzofuran	0.36 T	pg/g	IAR	0.9	N/A	J	None	Datum is estimated, bias unknown; ion abundance ratio outside acceptance criteria
TS	TS-010506-1635	05/01/06	SW-846 8290	1,2,3,7,8-Pentachlorodibenzofuran	3.8 T	pg/g	PDE	N/A	N/A	J	None	Datum is estimated, bias unknown; interfering polychlorinated diphenyl ether peak present
TS	TS-010506-1635	05/01/06	SW-846 8290	Octachlorodibenzo-p-dioxin	1000	pg/g	LB	0.41 T	pg/g	B	None	Analyte detected in associated blank; sample concentration greater than five times the blank concentration
TS	TS-010506-1635	05/01/06	SW-846 8290	Octachlorodibenzofuran	170	pg/g	PDE	N/A	N/A	J	None	Datum is estimated, bias unknown; interfering polychlorinated diphenyl ether peak present
TS	TS-010506-1635	05/01/06	SW-846 8081A	beta Endosulfan	37	µg/kg	CONF	221	%	J	None	Datum is estimated, bias unknown; %D between primary and secondary GC columns outside acceptance criterion
TS	TS-010506-1635	05/01/06	SW-846 8081A	Endrin	49	µg/kg	CONF	46.8	%	J	None	Datum is estimated, bias unknown; %D between primary and secondary GC columns outside acceptance criterion
TS	TS-010506-1635	05/01/06	SW-846 8081A	Endrin aldehyde	22	µg/kg	CONF	3043	%	J	None	Datum is estimated, bias unknown; %D between primary and secondary GC columns outside acceptance criterion
TS	TS-010506-1635	05/01/06	SW-846 8081A	p,p'-DDD	62	µg/kg	CONF	481	%	J	None	Datum is estimated, bias unknown; %D between primary and secondary GC columns outside acceptance criterion
TS1	TS1-010506-1620	05/01/06	Lloyd Kahn	Total organic carbon	71700	mg/kg	CVS	117	%	J	High	Datum is estimated, bias unknown; CVS %D outside acceptance criterion
TS1	TS1-010506-1620	05/01/06	SW-846 6010B	Zinc	221	mg/kg	LB	0.24 T	mg/kg	B	None	Analyte detected in associated blank; sample concentration greater than five times the blank concentration
TS2	TS2-010506-1625	05/01/06	Lloyd Kahn	Total organic carbon	31500	mg/kg	CVS	117	%	J	High	Datum is estimated, bias unknown; CVS %D outside acceptance criterion
TS2	TS2-010506-1625	05/01/06	SW-846 6010B	Zinc	169	mg/kg	LB	0.24 T	mg/kg	B	None	Analyte detected in associated blank; sample concentration greater than five times the blank concentration
TS3	TS3-010506-1630	05/01/06	SW-846 8270 SIM	Pyrene	2900 D	µg/kg	MSD	121	%	J	High	Datum is estimated, possible high bias; MSD recovery outside acceptance criteria
TS3	TS3-010506-1630	05/01/06	Lloyd Kahn	Total organic carbon	42800	mg/kg	CVS	117	%	J	High	Datum is estimated, bias unknown; CVS %D outside acceptance criterion

TABLE 1
DATA QUALIFIERS SUMMARY TABLE
DEMONSTRATION TESTING AND FULL-SCALE OPERATION OF THE BIOGENESIS SEDIMENT DECONTAMINATION PROCESS, KEASBEY, NEW JERSEY
(Page 176 of 188)

Location Identification	Sample Identification	Sample Date	Analysis	Analyte	Sample Result	Sample Units	QC Type	QC Result	QC Units	Qualifier	Bias	Comment
TS3	TS3-010506-1630	05/01/06	SW-846 6010B	Zinc	387	mg/kg	LB	0.24 T	mg/kg	B	None	Analyte detected in associated blank; sample concentration greater than five times the blank concentration
TS3	TS3-010506-1630	05/01/06	SW-846 8082	2,2',3,4,5'-Pentachlorobiphenyl	10 D	µg/kg	CONF	1000	%	J	None	Datum is estimated, bias unknown; %D between primary and secondary GC columns outside acceptance criterion
TS3	TS3-010506-1630	05/01/06	SW-846 8082	2,3-Dichlorobiphenyl	2.3 TD	µg/kg	CONF	236	%	J	None	Datum is estimated, bias unknown; %D between primary and secondary GC columns outside acceptance criterion
TS3	TS3-010506-1630	05/01/06	SW-846 8082	2-Chlorobiphenyl	29 D	µg/kg	CONF LB	145 0.17 T	% µg/kg	JB	None	Datum is estimated, bias unknown; %D between primary and secondary GC columns outside acceptance criterion Analyte detected in associated blank; sample concentration greater than five times the blank concentration
TS3	TS3-010506-1630	05/01/06	SW-846 8270C	Anthracene	630 TD	µg/kg	MS	116	%	J	High	Datum is estimated, possible high bias; MS recovery outside acceptance criteria
TS3	TS3-010506-1630	05/01/06	SW-846 8270C	Benzo(a)anthracene	1700 TD	µg/kg	MS MSD	121 122	%	J	High	Datum is estimated, possible high bias; MS/MSD recoveries outside acceptance criteria
TS3	TS3-010506-1630	05/01/06	SW-846 8270C	Benzo(a)pyrene	1700 TD	µg/kg	MS	125	%	J	High	Datum is estimated, possible high bias; MS recovery outside acceptance criteria
TS3	TS3-010506-1630	05/01/06	SW-846 8270C	Chrysene	2100 TD	µg/kg	MS MSD	130 131	%	J	High	Datum is estimated, possible high bias; MS/MSD recoveries outside acceptance criteria
TS3	TS3-010506-1630	05/01/06	SW-846 8270C	Fluoranthene	3400 TD	µg/kg	MS MSD	152 151	%	J	High	Datum is estimated, possible high bias; MS/MSD recoveries outside acceptance criteria
TS3	TS3-010506-1630	05/01/06	SW-846 8270C	Naphthalene	350 TD	µg/kg	MS	119	%	J	High	Datum is estimated, possible high bias; MS recovery outside acceptance criteria
TS3	TS3-010506-1630	05/01/06	SW-846 8270C	Pyrene	3200 TD	µg/kg	MS MSD	128 128	%	J	High	Datum is estimated, possible high bias; MS/MSD recoveries outside acceptance criteria
TS3	TS3-010506-1630	05/01/06	SW-846 8081A	Dieldrin	20	µg/kg	CONF	135	%	J	None	Datum is estimated, bias unknown; %D between primary and secondary GC columns outside acceptance criterion
TS3	TS3-010506-1630	05/01/06	SW-846 8081A	Endrin	36	µg/kg	CONF	77.6	%	J	None	Datum is estimated, bias unknown; %D between primary and secondary GC columns outside acceptance criterion
TS3	TS3-010506-1630	05/01/06	SW-846 8081A	Endrin aldehyde	21	µg/kg	CONF	2722	%	J	None	Datum is estimated, bias unknown; %D between primary and secondary GC columns outside acceptance criterion
TS3	TS3-010506-1630	05/01/06	SW-846 8081A	p,p'-DDD	96	µg/kg	CONF	188	%	J	None	Datum is estimated, bias unknown; %D between primary and secondary GC columns outside acceptance criterion
WS	WS-010506-1640	05/01/06	Lloyd Kahn	Total organic carbon	100000	mg/kg	CVS	117	%	J	High	Datum is estimated, bias unknown; CVS %D outside acceptance criterion
WS	WS-010506-1640	05/01/06	SW-846 6010B	Zinc	1120	mg/kg	LB	0.24 T	mg/kg	B	None	Analyte detected in associated blank; sample concentration greater than five times the blank concentration

TABLE 1
DATA QUALIFIERS SUMMARY TABLE
DEMONSTRATION TESTING AND FULL-SCALE OPERATION OF THE BIOGENESIS SEDIMENT DECONTAMINATION PROCESS, KEASBEY, NEW JERSEY
(Page 177 of 188)

Location Identification	Sample Identification	Sample Date	Analysis	Analyte	Sample Result	Sample Units	QC Type	QC Result	QC Units	Qualifier	Bias	Comment
WS	WS-010506-1640	05/01/06	SW-846 8082	2,2',3,4,5'-Pentachlorobiphenyl	28 D	µg/kg	CONF	1000	%	J	None	Datum is estimated, bias unknown; %D between primary and secondary GC columns outside acceptance criterion
WS	WS-010506-1640	05/01/06	SW-846 8082	2-Chlorobiphenyl	23 TD	µg/kg	CONF LB	660 0 17 T	% µg/kg	JB	None	Datum is estimated, bias unknown; %D between primary and secondary GC columns outside acceptance criterion Analyte detected in associated blank; sample concentration greater than five times the blank concentration
WS	WS-010506-1640	05/01/06	SW-846 8290	1,2,3,6,7,8-Hexachlorodibenzofuran	12 T	pg/g	PDE	N/A	N/A	J	None	Datum is estimated, bias unknown; interfering polychlorinated diphenyl ether peak present
WS	WS-010506-1640	05/01/06	SW-846 8290	1,2,3,7,8-Pentachlorodibenzo-p-dioxin	2 1 T	pg/g	IAR	0 8	N/A	J	None	Datum is estimated, bias unknown; ion abundance ratio outside acceptance criteria
WS	WS-010506-1640	05/01/06	SW-846 8290	Octachlorodibenzo-p-dioxin	2300	pg/g	LB	0 41 T	pg/g	B	None	Analyte detected in associated blank; sample concentration greater than five times the blank concentration
WS	WS-010506-1640	05/01/06	SW-846 8081A	Dieldrin	58	µg/kg	CONF	243	%	J	None	Datum is estimated, bias unknown; %D between primary and secondary GC columns outside acceptance criterion
WS	WS-010506-1640	05/01/06	SW-846 8081A	Endrin	38	µg/kg	CONF	298	%	J	None	Datum is estimated, bias unknown; %D between primary and secondary GC columns outside acceptance criterion
WS	WS-010506-1640	05/01/06	SW-846 8081A	p,p'-DDD	270	µg/kg	CONF	160	%	J	None	Datum is estimated, bias unknown; %D between primary and secondary GC columns outside acceptance criterion
PSS	PSS-020506-1600	05/02/06	SW-846 6010B	Arsenic	14 9	mg/kg	SLD	11 6	%	J	None	Datum is estimated, bias unknown; serial dilution %D outside acceptance criterion
PSS	PSS-020506-1600	05/02/06	SW-846 6010B	Selenium	4	mg/kg	SLD	100	%	J	None	Datum is estimated, bias unknown; serial dilution %D outside acceptance criterion
PSS	PSS-020506-1600	05/02/06	SW-846 6010B	Zinc	886	mg/kg	SLD LB	11 3 0 19 T	% mg/kg	JB	None	Datum is estimated, bias unknown; serial dilution percent difference outside acceptance criterion Analyte detected in associated blank; sample concentration greater than five times the blank concentration
RS	RS-020506-1615	05/02/06	SW-846 6010B	Zinc	614	mg/kg	LB	0 19 T	mg/kg	B	None	Analyte detected in associated blank; sample concentration greater than five times the blank concentration
SS1	SS1-020506-1605	05/02/06	SW-846 6010B	Zinc	1330	mg/kg	LB	0 19 T	mg/kg	B	None	Analyte detected in associated blank; sample concentration greater than five times the blank concentration
SS2	SS2-020506-1610	05/02/06	SW-846 6010B	Zinc	960	mg/kg	LB	0 19 T	mg/kg	B	None	Analyte detected in associated blank; sample concentration greater than five times the blank concentration
TS	STS-1-020506-1200	05/02/06	SW-846 6010B	Zinc	361	mg/kg	LB	0 19 T	mg/kg	B	None	Analyte detected in associated blank; sample concentration greater than five times the blank concentration

TABLE 1
DATA QUALIFIERS SUMMARY TABLE
DEMONSTRATION TESTING AND FULL-SCALE OPERATION OF THE BIOGENESIS SEDIMENT DECONTAMINATION PROCESS, KEASBEY, NEW JERSEY
(Page 178 of 188)

Location Identification	Sample Identification	Sample Date	Analysis	Analyte	Sample Result	Sample Units	QC Type	QC Result	QC Units	Qualifier	Bias	Comment
TS	STS-2-020506-1500	05/02/06	SW-846 6010B	Zinc	374	mg/kg	LB	0 19 T	mg/kg	B	None	Analyte detected in associated blank; sample concentration greater than five times the blank concentration
TS	TS-020506-1635	05/02/06	SW-846 6010B	Zinc	394	mg/kg	LB	0 19 T	mg/kg	B	None	Analyte detected in associated blank; sample concentration greater than five times the blank concentration
TS1	TS1-020506-1620	05/02/06	SW-846 8270 SIM	Benzo(a)anthracene	7400 D	µg/kg	MS MSD	138 122	%	J	High	Datum is estimated, possible high bias; MS/MSD recoveries outside acceptance criteria
TS1	TS1-020506-1620	05/02/06	SW-846 8270 SIM	Benzo(a)pyrene	6500 D	µg/kg	MSD	129	%	J	High	Datum is estimated, possible high bias; MSD recovery outside acceptance criteria
TS1	TS1-020506-1620	05/02/06	SW-846 8270 SIM	Benzo(b)fluoranthene	6200 D	µg/kg	MSD	121	%	J	High	Datum is estimated, possible high bias; MSD recovery outside acceptance criteria
TS1	TS1-020506-1620	05/02/06	SW-846 8270 SIM	Chrysene	7700 D	µg/kg	MS MSD	122 127	%	J	High	Datum is estimated, possible high bias; MS/MSD recoveries outside acceptance criteria
TS1	TS1-020506-1620	05/02/06	SW-846 8270 SIM	Fluoranthene	9600 D	µg/kg	MS MSD	133 146	%	J	High	Datum is estimated, possible high bias; MS/MSD recoveries outside acceptance criteria
TS1	TS1-020506-1620	05/02/06	SW-846 8270 SIM	Pyrene	9800 D	µg/kg	MS MSD	124 123	%	J	High	Datum is estimated, possible high bias; MS/MSD recoveries outside acceptance criteria
TS1	TS1-020506-1620	05/02/06	SW-846 6010B	Zinc	732	mg/kg	LB	0 19 T	mg/kg	B	None	Analyte detected in associated blank; sample concentration greater than five times the blank concentration
TS2	TS2-020506-1625	05/02/06	SW-846 6010B	Zinc	302	mg/kg	LB	0 19 T	mg/kg	B	None	Analyte detected in associated blank; sample concentration greater than five times the blank concentration
TS3	TS3-020506-1630	05/02/06	SW-846 6010B	Zinc	406	mg/kg	LB	0 19 T	mg/kg	B	None	Analyte detected in associated blank; sample concentration greater than five times the blank concentration
WS	WS-020506-1640	05/02/06	SW-846 6010B	Zinc	1290	mg/kg	LB	0 19 T	mg/kg	B	None	Analyte detected in associated blank; sample concentration greater than five times the blank concentration
PSS	PSS-030506-1600	05/03/06	SW-846 6010B	Selenium	1 7	mg/kg	SLD	100	%	J	None	Datum is estimated, bias unknown; serial dilution %D outside acceptance criterion
PSS	PSS-030506-1600	05/03/06	SW-846 6010B	Zinc	677	mg/kg	SLD	12 2	%	J	None	Datum is estimated, bias unknown; serial dilution %D outside acceptance criterion
PSS	PSS-030506-1600	05/03/06	SW-846 8082	2,2',3,4,5'-Pentachlorobiphenyl	13 D	µg/kg	CONF	577	%	J	None	Datum is estimated, bias unknown; %D between primary and secondary GC columns outside acceptance criterion
PSS	PSS-030506-1600	05/03/06	SW-846 8082	2,3-Dichlorobiphenyl	1 2 TD	µg/kg	CONF	751	%	J	None	Datum is estimated, bias unknown; %D between primary and secondary GC columns outside acceptance criterion

TABLE 1
DATA QUALIFIERS SUMMARY TABLE
DEMONSTRATION TESTING AND FULL-SCALE OPERATION OF THE BIOGENESIS SEDIMENT DECONTAMINATION PROCESS, KEASBEY, NEW JERSEY
(Page179 of 188)

Location Identification	Sample Identification	Sample Date	Analysis	Analyte	Sample Result	Sample Units	QC Type	QC Result	QC Units	Qualifier	Bias	Comment
PSS	PSS-030506-1600	05/03/06	SW-846 8082	2-Chlorobiphenyl	56 TD	µg/kg	CONF LB	67 8 0 15 T	% µg/kg	JB	None	Datum is estimated, bias unknown; %D between primary and secondary GC columns outside acceptance criterion Analyte detected in associated blank; sample concentration greater than five times the blank concentration
PSS	PSS-030506-1600	05/03/06	SW-846 8270C	Pentachlorophenol	<15000 D	µg/kg	LCS	2 8	%	UJ	Low	Possible false negative; LCS recovery outside acceptance criteria
PSS	PSS-030506-1600	05/03/06	SW-846 8290	1,2,3,4,7,8,9-Heptachlorodibenzofuran	30	pg/g	PDE	N/A	N/A	J	None	Datum is estimated, bias unknown; interfering polychlorinated diphenyl ether peak present
PSS	PSS-030506-1600	05/03/06	SW-846 8290	1,2,3,4,7,8-Hexachlorodibenzo-p-Dioxin	13 T	pg/g	IAR	1 01	N/A	J	None	Datum is estimated, bias unknown; ion abundance ratio outside acceptance criteria
PSS	PSS-030506-1600	05/03/06	SW-846 8290	1,2,3,4,7,8-Hexachlorodibenzofuran	190	pg/g	PDE	N/A	N/A	J	None	Datum is estimated, bias unknown; interfering polychlorinated diphenyl ether peak present
PSS	PSS-030506-1600	05/03/06	SW-846 8290	1,2,3,7,8,9-Hexachlorodibenzo-p-Dioxin	23	pg/g	IAR	0 98	N/A	J	None	Datum is estimated, bias unknown; ion abundance ratio outside acceptance criteria
PSS	PSS-030506-1600	05/03/06	SW-846 8290	1,2,3,7,8,9-Hexachlorodibenzofuran	2 7 T	pg/g	IAR	0 89	N/A	J	None	Datum is estimated, bias unknown; ion abundance ratio outside acceptance criteria
PSS	PSS-030506-1600	05/03/06	SW-846 8290	1,2,3,7,8-Pentachlorodibenzofuran	21	pg/g	PDE	N/A	N/A	J	None	Datum is estimated, bias unknown; interfering polychlorinated diphenyl ether peak present
PSS	PSS-030506-1600	05/03/06	SW-846 8290	Octachlorodibenzo-p-Dioxin	8000	pg/g	LB	0 41 T	pg/g	B	None	Analyte detected in associated blank; sample concentration greater than five times the blank concentration
PSS	PSS-030506-1600	05/03/06	SW-846 8081A	beta Endosulfan	110	µg/kg	CONF	48 5	%	J	None	Datum is estimated, bias unknown; %D between primary and secondary GC columns outside acceptance criterion
PSS	PSS-030506-1600	05/03/06	SW-846 8081A	Gamma BHC (lindane)	20	µg/kg	CONF	48	%	J	None	Datum is estimated, bias unknown; %D between primary and secondary GC columns outside acceptance criterion
PSS	PSS-030506-1600	05/03/06	SW-846 8081A	p,p'-DDD	350	µg/kg	CONF	48 3	%	J	None	Datum is estimated, bias unknown; %D between primary and secondary GC columns outside acceptance criterion
RS	RS-030506-1615	05/03/06	SW-846 8082	2,2',3,4,5'-Pentachlorobiphenyl	12 D	µg/kg	CONF	533	%	J	None	Datum is estimated, bias unknown; %D between primary and secondary GC columns outside acceptance criterion
RS	RS-030506-1615	05/03/06	SW-846 8082	2-Chlorobiphenyl	49 TD	µg/kg	CONF LB	134 0 15 T	% µg/kg	JB	None	Datum is estimated, bias unknown; %D between primary and secondary GC columns outside acceptance criterion Analyte detected in associated blank; sample concentration greater than five times the blank concentration
RS	RS-030506-1615	05/03/06	SW-846 8270C	Pentachlorophenol	<15000 D	µg/kg	LCS	2 8	%	UJ	Low	Possible false negative; LCS recovery outside acceptance criteria
RS	RS-030506-1615	05/03/06	SW-846 8290	1,2,3,4,7,8,9-Heptachlorodibenzofuran	33	pg/g	PDE	N/A	N/A	J	None	Datum is estimated, bias unknown; interfering polychlorinated diphenyl ether peak present
RS	RS-030506-1615	05/03/06	SW-846 8290	1,2,3,4,7,8-Hexachlorodibenzo-p-dioxin	9 8 T	pg/g	IAR	1	N/A	J	None	Datum is estimated, bias unknown; ion abundance ratio outside acceptance criteria

TABLE 1
DATA QUALIFIERS SUMMARY TABLE
DEMONSTRATION TESTING AND FULL-SCALE OPERATION OF THE BIOGENESIS SEDIMENT DECONTAMINATION PROCESS, KEASBEY, NEW JERSEY
(Page180 of 188)

Location Identification	Sample Identification	Sample Date	Analysis	Analyte	Sample Result	Sample Units	QC Type	QC Result	QC Units	Qualifier	Bias	Comment
RS	RS-030506-1615	05/03/06	SW-846 8290	1,2,3,6,7,8-Hexachlorodibenzo-p-Dioxin	52	pg/g	RT	47.51	min	J	None	Datum is estimated, bias unknown; ion suppression evident for peak within analyte retention-time window
RS	RS-030506-1615	05/03/06	SW-846 8290	1,2,3,6,7,8-Hexachlorodibenzofuran	68	pg/g	PDE	N/A	N/A	J	None	Datum is estimated, bias unknown; interfering polychlorinated diphenyl ether peak present
RS	RS-030506-1615	05/03/06	SW-846 8290	1,2,3,7,8,9-Hexachlorodibenzo-p-Dioxin	40	pg/g	IAR	0.77	N/A	J	None	Datum is estimated, bias unknown; ion abundance ratio outside acceptance criteria
RS	RS-030506-1615	05/03/06	SW-846 8290	1,2,3,7,8-Pentachlorodibenzo-p-dioxin	12 T	pg/g	IAR	0.65	N/A	J	None	Datum is estimated, bias unknown; ion abundance ratio outside acceptance criteria
RS	RS-030506-1615	05/03/06	SW-846 8290	1,2,3,7,8-Pentachlorodibenzofuran	54	pg/g	PDE	N/A	N/A	J	None	Datum is estimated, bias unknown; interfering polychlorinated diphenyl ether peak present
RS	RS-030506-1615	05/03/06	SW-846 8290	2,3,7,8-Tetrachlorodibenzofuran	23	pg/g	IAR	1.03	N/A	J	None	Datum is estimated, bias unknown; ion abundance ratio outside acceptance criteria
RS	RS-030506-1615	05/03/06	SW-846 8290	Octachlorodibenzo-p-dioxin	8400	pg/g	LB	0.41 T	pg/g	B	None	Analyte detected in associated blank; sample concentration greater than five times the blank concentration
RS	RS-030506-1615	05/03/06	SW-846 8290	Octachlorodibenzofuran	920	pg/g	PDE	N/A	N/A	J	None	Datum is estimated, bias unknown; interfering polychlorinated diphenyl ether peak present
RS	RS-030506-1615	05/03/06	SW-846 8081A	Endrin	43	µg/kg	CONF	56.1	%	J	None	Datum is estimated, bias unknown; %D between primary and secondary GC columns outside acceptance criterion
RS	RS-030506-1615	05/03/06	SW-846 8081A	p,p'-DDD	30	µg/kg	CONF	881	%	J	None	Datum is estimated, bias unknown; %D between primary and secondary GC columns outside acceptance criterion
RS	RS-030506-1615	05/03/06	SW-846 8081A	p,p'-DDT	51	µg/kg	CONF	179	%	J	None	Datum is estimated, bias unknown; %D between primary and secondary GC columns outside acceptance criterion
TS	STS-3-030506-1200	05/03/06	SW-846 8082	2,2',3,4,5'-Pentachlorobiphenyl	10 D	µg/kg	CONF	592	%	J	None	Datum is estimated, bias unknown; %D between primary and secondary GC columns outside acceptance criterion
TS	STS-3-030506-1200	05/03/06	SW-846 8082	2,3-Dichlorobiphenyl	1.1 TD	µg/kg	CONF	666	%	J	None	Datum is estimated, bias unknown; %D between primary and secondary GC columns outside acceptance criterion
TS	STS-3-030506-1200	05/03/06	SW-846 8082	2-Chlorobiphenyl	43 D	µg/kg	CONF LB	49.1 0.15 T	% µg/kg	JB	None	Datum is estimated, bias unknown; %D between primary and secondary GC columns outside acceptance criterion Analyte detected in associated blank; sample concentration greater than five times the blank concentration
TS	STS-3-030506-1200	05/03/06	SW-846 8270C	Pentachlorophenol	<6100 D	µg/kg	LCS	2.8	%	UJ	Low	Possible false negative; LCS recovery outside acceptance criteria
TS	STS-3-030506-1200	05/03/06	SW-846 8290	1,2,3,4,7,8,9-Heptachlorodibenzofuran	3.9 T	pg/g	IAR	0.83	N/A	J	None	Datum is estimated, bias unknown; ion abundance ratio outside acceptance criteria
TS	STS-3-030506-1200	05/03/06	SW-846 8290	1,2,3,4,7,8-Hexachlorodibenzo-p-dioxin	0.81 T	pg/g	IAR	0.83	N/A	J	None	Datum is estimated, bias unknown; ion abundance ratio outside acceptance criteria

TABLE 1
DATA QUALIFIERS SUMMARY TABLE
DEMONSTRATION TESTING AND FULL-SCALE OPERATION OF THE BIOGENESIS SEDIMENT DECONTAMINATION PROCESS, KEASBEY, NEW JERSEY
(Page 181 of 188)

Location Identification	Sample Identification	Sample Date	Analysis	Analyte	Sample Result	Sample Units	QC Type	QC Result	QC Units	Qualifier	Bias	Comment
TS	STS-3-030506-1200	05/03/06	SW-846 8290	1,2,3,6,7,8-Hexachlorodibenzofuran	4 4 T	pg/g	IAR	1 46	N/A	J	None	Datum is estimated, bias unknown; ion abundance ratio outside acceptance criteria
TS	STS-3-030506-1200	05/03/06	SW-846 8290	1,2,3,7,8-Pentachlorodibenzo-p-dioxin	0 96 T	pg/g	IAR	0 91	N/A	J	None	Datum is estimated, bias unknown; ion abundance ratio outside acceptance criteria
TS	STS-3-030506-1200	05/03/06	SW-846 8290	2,3,4,6,7,8-Hexachlorodibenzofuran	3 0 T	pg/g	PDE	N/A	N/A	J	None	Datum is estimated, bias unknown; interfering polychlorinated diphenyl ether peak present
TS	STS-3-030506-1200	05/03/06	SW-846 8290	2,3,7,8-Tetrachlorodibenzofuran	4 1	pg/g	IAR	0 63	N/A	J	None	Datum is estimated, bias unknown; ion abundance ratio outside acceptance criteria
TS	STS-3-030506-1200	05/03/06	SW-846 8290	Octachlorodibenzo-p-dioxin	580	pg/g	LB	0 41 T	pg/g	B	None	Analyte detected in associated blank; sample concentration greater than five times the blank concentration
TS	STS-3-030506-1200	05/03/06	SW-846 8081A	beta Endosulfan	75	µg/kg	CONF	69 5	%	J	None	Datum is estimated, bias unknown; %D between primary and secondary GC columns outside acceptance criterion
TS	STS-3-030506-1200	05/03/06	SW-846 8081A	p,p'-DDD	100	µg/kg	CONF	205	%	J	None	Datum is estimated, bias unknown; %D between primary and secondary GC columns outside acceptance criterion
TS	STS-4-030506-1400	05/03/06	SW-846 8082	2,2',3,4,5'-Pentachlorobiphenyl	10 D	µg/kg	CONF	727	%	J	None	Datum is estimated, bias unknown; %D between primary and secondary GC columns outside acceptance criterion
TS	STS-4-030506-1400	05/03/06	SW-846 8082	2,3-Dichlorobiphenyl	1 2 TD	µg/kg	CONF	673	%	J	None	Datum is estimated, bias unknown; %D between primary and secondary GC columns outside acceptance criterion
TS	STS-4-030506-1400	05/03/06	SW-846 8082	2-Chlorobiphenyl	24 TD	µg/kg	CONF LB	187 0 15 T	% µg/kg	JB	None	Datum is estimated, bias unknown; %D between primary and secondary GC columns outside acceptance criterion Analyte detected in associated blank; sample concentration greater than five times the blank concentration
TS	STS-4-030506-1400	05/03/06	SW-846 8270C	Pentachlorophenol	<6000 D	µg/kg	LCS	2 8	%	UJ	Low	Possible false negative; LCS recovery outside acceptance criteria
TS	STS-4-030506-1400	05/03/06	SW-846 8290	1,2,3,4,7,8,9-Heptachlorodibenzofuran	1 9 T	pg/g	IAR	0 79	N/A	J	None	Datum is estimated, bias unknown; ion abundance ratio outside acceptance criteria
TS	STS-4-030506-1400	05/03/06	SW-846 8290	1,2,3,6,7,8-Hexachlorodibenzofuran	4 6 T	pg/g	PDE	N/A	N/A	J	None	Datum is estimated, bias unknown; interfering polychlorinated diphenyl ether peak present
TS	STS-4-030506-1400	05/03/06	SW-846 8290	1,2,3,7,8-Pentachlorodibenzo-p-dioxin	1 4 T	pg/g	IAR	1 21	N/A	J	None	Datum is estimated, bias unknown; ion abundance ratio outside acceptance criteria
TS	STS-4-030506-1400	05/03/06	SW-846 8290	1,2,3,7,8-Pentachlorodibenzofuran	1 2 T	pg/g	IAR	1 26	N/A	J	None	Datum is estimated, bias unknown; ion abundance ratio outside acceptance criteria
TS	STS-4-030506-1400	05/03/06	SW-846 8290	2,3,7,8-Tetrachlorodibenzofuran	4 1	pg/g	IAR	1 08	N/A	J	None	Datum is estimated, bias unknown; ion abundance ratio outside acceptance criteria
TS	STS-4-030506-1400	05/03/06	SW-846 8290	Octachlorodibenzo-p-dioxin	450	pg/g	LB	0 41 T	pg/g	B	None	Analyte detected in associated blank; sample concentration greater than five times the blank concentration

TABLE 1
DATA QUALIFIERS SUMMARY TABLE
DEMONSTRATION TESTING AND FULL-SCALE OPERATION OF THE BIOGENESIS SEDIMENT DECONTAMINATION PROCESS, KEASBEY, NEW JERSEY
(Page 182 of 188)

Location Identification	Sample Identification	Sample Date	Analysis	Analyte	Sample Result	Sample Units	QC Type	QC Result	QC Units	Qualifier	Bias	Comment
TS	STS-4-030506-1400	05/03/06	SW-846 8081A	Endrin	37	µg/kg	CONF	125.3	%	J	None	Datum is estimated, bias unknown; %D between primary and secondary GC columns outside acceptance criterion
TS	STS-4-030506-1400	05/03/06	SW-846 8081A	p,p'-DDD	96	µg/kg	CONF	169	%	J	None	Datum is estimated, bias unknown; %D between primary and secondary GC columns outside acceptance criterion
TS	TS-030506-1635	05/03/06	SW-846 8082	2,2',3,4,4',5,5'-Heptachlorobiphenyl	16 D	µg/kg	CONF	40.1	%	J	None	Datum is estimated, bias unknown; %D between primary and secondary GC columns outside acceptance criterion
TS	TS-030506-1635	05/03/06	SW-846 8082	2,2',3,4,5'-Pentachlorobiphenyl	11 D	µg/kg	CONF	607	%	J	None	Datum is estimated, bias unknown; %D between primary and secondary GC columns outside acceptance criterion
TS	TS-030506-1635	05/03/06	SW-846 8082	2,3-Dichlorobiphenyl	1.1 TD	µg/kg	CONF	673	%	J	None	Datum is estimated, bias unknown; %D between primary and secondary GC columns outside acceptance criterion
TS	TS-030506-1635	05/03/06	SW-846 8082	2-Chlorobiphenyl	65 D	µg/kg	LB	0.15 T	µg/kg	B	None	Analyte detected in associated blank; sample concentration greater than five times the blank concentration
TS	TS-030506-1635	05/03/06	SW-846 8270C	Pentachlorophenol	<5900 D	µg/kg	LCS	2.8	%	UJ	Low	Possible false negative; LCS recovery outside acceptance criteria
TS	TS-030506-1635	05/03/06	SW-846 8290	1,2,3,4,7,8,9-Heptachlorodibenzofuran	3.7 T	pg/g	IAR	1.22	N/A	J	None	Datum is estimated, bias unknown; ion abundance ratio outside acceptance criteria
TS	TS-030506-1635	05/03/06	SW-846 8290	1,2,3,4,7,8-Hexachlorodibenzofuran	28	pg/g	PDE	N/A	N/A	J	None	Datum is estimated, bias unknown; interfering polychlorinated diphenyl ether peak present
TS	TS-030506-1635	05/03/06	SW-846 8290	1,2,3,7,8,9-Hexachlorodibenzo-p-Dioxin	1.9 T	pg/g	IAR	1.49	N/A	J	None	Datum is estimated, bias unknown; ion abundance ratio outside acceptance criteria
TS	TS-030506-1635	05/03/06	SW-846 8290	1,2,3,7,8,9-Hexachlorodibenzofuran	2.5 T	pg/g	IAR	1.03	N/A	J	None	Datum is estimated, bias unknown; ion abundance ratio outside acceptance criteria
TS	TS-030506-1635	05/03/06	SW-846 8290	Octachlorodibenzo-p-dioxin	630	pg/g	LB	0.41 T	pg/g	B	None	Analyte detected in associated blank; sample concentration greater than five times the blank concentration
TS	TS-030506-1635	05/03/06	SW-846 8081A	beta Endosulfan	74	µg/kg	CONF	65	%	J	None	Datum is estimated, bias unknown; %D between primary and secondary GC columns outside acceptance criterion
TS	TS-030506-1635	05/03/06	SW-846 8081A	p,p'-DDD	98	µg/kg	CONF	208	%	J	None	Datum is estimated, bias unknown; %D between primary and secondary GC columns outside acceptance criterion
WS	WS-030506-1640	05/03/06	SW-846 8082	2,2',3,4,5'-Pentachlorobiphenyl	16 D	µg/kg	CONF	649	%	J	None	Datum is estimated, bias unknown; %D between primary and secondary GC columns outside acceptance criterion
WS	WS-030506-1640	05/03/06	SW-846 8082	2,3-Dichlorobiphenyl	1.4 TD	µg/kg	CONF	784	%	J	None	Datum is estimated, bias unknown; %D between primary and secondary GC columns outside acceptance criterion

TABLE 1
DATA QUALIFIERS SUMMARY TABLE
DEMONSTRATION TESTING AND FULL-SCALE OPERATION OF THE BIOGENESIS SEDIMENT DECONTAMINATION PROCESS, KEASBEY, NEW JERSEY
(Page183 of 188)

Location Identification	Sample Identification	Sample Date	Analysis	Analyte	Sample Result	Sample Units	QC Type	QC Result	QC Units	Qualifier	Bias	Comment
WS	WS-030506-1640	05/03/06	SW-846 8082	2-Chlorobiphenyl	60 TD	µg/kg	CONF LB	143 0 15 T	% µg/kg	JB	None	Datum is estimated, bias unknown; %D between primary and secondary GC columns outside acceptance criterion Analyte detected in associated blank; sample concentration greater than five times the blank concentration
WS	WS-030506-1640	05/03/06	SW-846 8270C	Benzo(g,h,i)perylene	360 TD	µg/kg	MS MSD	49 41	%	J	Low	Datum is estimated, possible low bias; MS/MSD recoveries outside acceptance criteria
WS	WS-030506-1640	05/03/06	SW-846 8270C	Hexachloroethane	<3200 D	µg/kg	MS MSD	37 29	%	UJ	Low	Possible false negative; MS/MSD recoveries outside acceptance criteria
WS	WS-030506-1640	05/03/06	SW-846 8270C	Indeno(1,2,3-c,d)pyrene	410 TD	µg/kg	MSD	45	%	J	Low	Datum is estimated, possible low bias; MSD recovery outside acceptance criteria
WS	WS-030506-1640	05/03/06	SW-846 8270C	Pentachlorophenol	<15000 D	µg/kg	LCS	2 8	%	UJ	Low	Possible false negative; LCS recovery outside acceptance criteria
WS	WS-030506-1640	05/03/06	SW-846 8290	1,2,3,4,7,8,9-Heptachlorodibenzofuran	4 2 T	pg/g	IAR	0 86	N/A	J	None	Datum is estimated, bias unknown; ion abundance ratio outside acceptance criteria
WS	WS-030506-1640	05/03/06	SW-846 8290	1,2,3,4,7,8-Hexachlorodibenzo-p-dioxin	1 0 T	pg/g	IAR	2 14	N/A	J	None	Datum is estimated, bias unknown; ion abundance ratio outside acceptance criteria
WS	WS-030506-1640	05/03/06	SW-846 8290	1,2,3,4,7,8-Hexachlorodibenzofuran	37	pg/g	PDE	N/A	N/A	J	None	Datum is estimated, bias unknown; interfering polychlorinated diphenyl ether peak present
WS	WS-030506-1640	05/03/06	SW-846 8290	1,2,3,6,7,8-Hexachlorodibenzo-p-Dioxin	7 3 T	pg/g	IAR	1	N/A	J	None	Datum is estimated, bias unknown; ion abundance ratio outside acceptance criteria
WS	WS-030506-1640	05/03/06	SW-846 8290	1,2,3,6,7,8-Hexachlorodibenzofuran	7 9 T	pg/g	IAR	1 5	N/A	J	None	Datum is estimated, bias unknown; ion abundance ratio outside acceptance criteria
WS	WS-030506-1640	05/03/06	SW-846 8290	1,2,3,7,8-Pentachlorodibenzofuran	2 3 T	pg/g	IAR	1 25	N/A	J	None	Datum is estimated, bias unknown; ion abundance ratio outside acceptance criteria
WS	WS-030506-1640	05/03/06	SW-846 8290	2,3,7,8-Tetrachlorodibenzofuran	4	pg/g	IAR CMC	0 44 3	N/A s	J	None	Datum is estimated, bias unknown; ion abundance ratio and comax peaks outside acceptance criteria
WS	WS-030506-1640	05/03/06	SW-846 8290	Octachlorodibenzo-p-dioxin	1700	pg/g	LB	0 41 T	pg/g	B	None	Analyte detected in associated blank; sample concentration greater than five times the blank concentration
WS	WS-030506-1640	05/03/06	SW-846 8081A	beta Endosulfan	110	µg/kg	CONF	40 9	%	J	None	Datum is estimated, bias unknown; %D between primary and secondary GC columns outside acceptance criterion
WS	WS-030506-1640	05/03/06	SW-846 8081A	Endrin	85	µg/kg	CONF	62 5	%	J	None	Datum is estimated, bias unknown; %D between primary and secondary GC columns outside acceptance criterion
WS	WS-030506-1640	05/03/06	SW-846 8081A	p,p'-DDD	140	µg/kg	CONF	154	%	J	None	Datum is estimated, bias unknown; %D between primary and secondary GC columns outside acceptance criterion
PSS	PSS-040506-1600	05/04/06	SW-846 6010B	Lead	354	mg/kg	SLD	10 7	%	J	None	Datum is estimated, bias unknown; serial dilution %D outside acceptance criterion

TABLE 1
DATA QUALIFIERS SUMMARY TABLE
DEMONSTRATION TESTING AND FULL-SCALE OPERATION OF THE BIOGENESIS SEDIMENT DECONTAMINATION PROCESS, KEASBEY, NEW JERSEY
(Page 184 of 188)

Location Identification	Sample Identification	Sample Date	Analysis	Analyte	Sample Result	Sample Units	QC Type	QC Result	QC Units	Qualifier	Bias	Comment
PSS	PSS-040506-1600	05/04/06	SW-846 6010B	Selenium	0.86	mg/kg	SLD	100	%	J	None	Datum is estimated, bias unknown; serial dilution %D outside acceptance criterion
PSS	PSS-040506-1600	05/04/06	SW-846 6010B	Zinc	620	mg/kg	SLD LB	14.7 0.22 T	% mg/kg	JB	None	Datum is estimated, bias unknown; serial dilution percent difference outside acceptance criterion. Analyte detected in associated blank; sample concentration greater than five times the blank concentration
PSS	PSS-040506-1600B	05/04/06	SW-846 8270 SIM	Acenaphthene	298.39 D	µg/kg	IS	<50		J	None	Datum is estimated, bias unknown; IS area recovery outside acceptance criteria
PSS	PSS-040506-1600B	05/04/06	SW-846 8270 SIM	Acenaphthylene	414.22 D	µg/kg	IS	<50		J	None	Datum is estimated, bias unknown; IS area recovery outside acceptance criteria
PSS	PSS-040506-1600B	05/04/06	SW-846 8270 SIM	Anthracene	972.79 D	µg/kg	IS	<50		J	None	Datum is estimated, bias unknown; IS area recovery outside acceptance criteria
PSS	PSS-040506-1600B	05/04/06	SW-846 8270 SIM	Fluoranthene	6303.72 D	µg/kg	IS	<50		J	None	Datum is estimated, bias unknown; IS area recovery outside acceptance criteria
PSS	PSS-040506-1600B	05/04/06	SW-846 8270 SIM	Fluorene	349.41 D	µg/kg	IS	<50		J	None	Datum is estimated, bias unknown; IS area recovery outside acceptance criteria
PSS	PSS-040506-1600B	05/04/06	SW-846 8270 SIM	Naphthalene	484.41 D	µg/kg	IS LB	<50 0.09 T	% µg/kg	JB	None	Datum is estimated, bias unknown; IS area outside acceptance criteria. Analyte detected in associated blank; sample concentration greater than five times the blank concentration
PSS	PSS-040506-1600B	05/04/06	SW-846 8270 SIM	Phenanthrene	2059.16 D	µg/kg	IS	<50		J	None	Datum is estimated, bias unknown; IS area recovery outside acceptance criteria
PSS	PSS-040506-1600B	05/04/06	SW-846 8270 SIM	Pyrene	6469.88 D	µg/kg	IS	<50		J	None	Datum is estimated, bias unknown; IS area recovery outside acceptance criteria
PSS	PSS-040506-1600B	05/04/06	SW-846 6010B	Arsenic	11.1	mg/kg	SLD LB	10.7 0.392 T	% mg/kg	JB	None	Datum is estimated, bias unknown; serial dilution percent difference outside acceptance criterion. Analyte detected in associated blank; sample concentration greater than five times the blank concentration
PSS	PSS-040506-1600B	05/04/06	SW-846 6010B	Arsenic	12	mg/kg	LB	0.392 T	mg/kg	B	None	Analyte detected in associated blank; sample concentration greater than five times the blank concentration
PSS	PSS-040506-1600B	05/04/06	SW9071B	Total petroleum hydrocarbons	8400	mg/kg	RPD	21.7	%	J	None	Datum is estimated, bias unknown; LCS/LCD RPD outside acceptance criterion
RS	RS-040506-1615	05/04/06	SW-846 6010B	Zinc	617	mg/kg	LB	0.22 T	mg/kg	B	None	Analyte detected in associated blank; sample concentration greater than five times the blank concentration
RS	RS-040506-1615B	05/04/06	SW-846 8270 SIM	Naphthalene	570.81 D	µg/kg	LB	0.09 T	µg/kg	B	None	Analyte detected in associated blank; sample concentration greater than five times the blank concentration

TABLE 1
DATA QUALIFIERS SUMMARY TABLE
DEMONSTRATION TESTING AND FULL-SCALE OPERATION OF THE BIOGENESIS SEDIMENT DECONTAMINATION PROCESS, KEASBEY, NEW JERSEY
(Page 185 of 188)

Location Identification	Sample Identification	Sample Date	Analysis	Analyte	Sample Result	Sample Units	QC Type	QC Result	QC Units	Qualifier	Bias	Comment
RS	RS-040506-1615B	05/04/06	SW-846 6010B	Arsenic	10.5	mg/kg	LB	0.392 T	mg/kg	B	None	Analyte detected in associated blank; sample concentration greater than five times the blank concentration
RS	RS-040506-1615B	05/04/06	SW9071B	Total petroleum hydrocarbons	4700	mg/kg	RPD	21.7	%	J	None	Datum is estimated, bias unknown; LCS/LCD RPD outside acceptance criterion
SS1	SS1-040506-1605	05/04/06	SW-846 6010B	Zinc	635	mg/kg	LB	0.22 T	mg/kg	B	None	Analyte detected in associated blank; sample concentration greater than five times the blank concentration
SS1	SS1-040506-1605B	05/04/06	SW-846 8270 SIM	Naphthalene	724.59 D	µg/kg	LB	0.09 T	µg/kg	B	None	Analyte detected in associated blank; sample concentration greater than five times the blank concentration
SS1	SS1-040506-1605B	05/04/06	SW-846 8270 SIM	Naphthalene	661.26 D	µg/kg	LB	0.09 T	µg/kg	B	None	Analyte detected in associated blank; sample concentration greater than five times the blank concentration
SS1	SS1-040506-1605B	05/04/06	SW-846 6010B	Arsenic	12.5	mg/kg	LB	0.392 T	mg/kg	B	None	Analyte detected in associated blank; sample concentration greater than five times the blank concentration
SS1	SS1-040506-1605B	05/04/06	SW9071B	Total petroleum hydrocarbons	15000	mg/kg	RPD	21.7	%	J	None	Datum is estimated, bias unknown; LCS/LCD RPD outside acceptance criterion
SS2	SS2-040506-1610	05/04/06	SW-846 6010B	Zinc	621	mg/kg	LB	0.22 T	mg/kg	B	None	Analyte detected in associated blank; sample concentration greater than five times the blank concentration
SS2	SS2-040506-1610B	05/04/06	SW-846 8270 SIM	Naphthalene	599.31 D	µg/kg	LB	0.09 T	µg/kg	B	None	Analyte detected in associated blank; sample concentration greater than five times the blank concentration
SS2	SS2-040506-1610B	05/04/06	SW-846 6010B	Arsenic	13.5	mg/kg	LB	0.392 T	mg/kg	B	None	Analyte detected in associated blank; sample concentration greater than five times the blank concentration
SS2	SS2-040506-1610B	05/04/06	SW9071B	Total petroleum hydrocarbons	7700	mg/kg	RPD	21.7	%	J	None	Datum is estimated, bias unknown; LCS/LCD RPD outside acceptance criterion
TS	STS-5-040506-1200	05/04/06	SW-846 6010B	Zinc	341	mg/kg	LB	0.22 T	mg/kg	B	None	Analyte detected in associated blank; sample concentration greater than five times the blank concentration
TS	STS-6-040506-1500	05/04/06	SW-846 6010B	Zinc	317	mg/kg	LB	0.22 T	mg/kg	B	None	Analyte detected in associated blank; sample concentration greater than five times the blank concentration
TS	TS-040506-1635	05/04/06	SW-846 6010B	Zinc	366	mg/kg	LB	0.22 T	mg/kg	B	None	Analyte detected in associated blank; sample concentration greater than five times the blank concentration

TABLE 1
DATA QUALIFIERS SUMMARY TABLE
DEMONSTRATION TESTING AND FULL-SCALE OPERATION OF THE BIOGENESIS SEDIMENT DECONTAMINATION PROCESS, KEASBEY, NEW JERSEY
(Page 186 of 188)

Location Identification	Sample Identification	Sample Date	Analysis	Analyte	Sample Result	Sample Units	QC Type	QC Result	QC Units	Qualifier	Bias	Comment
TS	TS-040506-1635B	05/04/06	SW-846 8270 SIM	Naphthalene	717 94 D	µg/kg	LB	0 09 T	µg/kg	B	None	Analyte detected in associated blank; sample concentration greater than five times the blank concentration
TS	TS-040506-1635B	05/04/06	SW-846 6010B	Arsenic	8 31	mg/kg	LB	0 392 T	mg/kg	B	None	Analyte detected in associated blank; sample concentration greater than five times the blank concentration
TS	TS-040506-1635B	05/04/06	SW9071B	Total petroleum hydrocarbons	3000	mg/kg	RPD	21 7	%	J	None	Datum is estimated, bias unknown; LCS/LCD RPD outside acceptance criterion
TS1	TS1-040506-1620	05/04/06	SW-846 8270 SIM	Acenaphthene	1600 D	µg/kg	MS MSD	23 23	%	J	Low	Datum is estimated, possible low bias; MS/MSD recoveries outside acceptance criteria
TS1	TS1-040506-1620	05/04/06	SW-846 8270 SIM	Acenaphthylene	3700 D	µg/kg	MS MSD	2 8 2 8	%	J	Low	Datum is estimated, possible low bias; MS/MSD recoveries outside acceptance criteria
TS1	TS1-040506-1620	05/04/06	SW-846 8270 SIM	Anthracene	6300 D	µg/kg	MS MSD	0 0	%	J	Low	Datum is estimated, possible low bias; MS/MSD recoveries outside acceptance criteria
TS1	TS1-040506-1620	05/04/06	SW-846 8270 SIM	Benzo(g,h,i)perylene	10000 D	µg/kg	MS MSD	0 0	%	J	Low	Datum is estimated, possible low bias; MS/MSD recoveries outside acceptance criteria
TS1	TS1-040506-1620	05/04/06	SW-846 8270 SIM	Benzo(k)fluoranthene	5800 D	µg/kg	MS MSD	0 0	%	J	Low	Datum is estimated, possible low bias; MS/MSD recoveries outside acceptance criteria
TS1	TS1-040506-1620	05/04/06	SW-846 8270 SIM	Dibenz(a,h)anthracene	2600 D	µg/kg	MS MSD	10 10	%	J	Low	Datum is estimated, possible low bias; MS/MSD recoveries outside acceptance criteria
TS1	TS1-040506-1620	05/04/06	SW-846 8270 SIM	Fluorene	1900 D	µg/kg	MS MSD	14 14	%	J	Low	Datum is estimated, possible low bias; MS/MSD recoveries outside acceptance criteria
TS1	TS1-040506-1620	05/04/06	SW-846 8270 SIM	Indeno(1,2,3-c,d)pyrene	8100 D	µg/kg	MS MSD	0 0	%	J	Low	Datum is estimated, possible low bias; MS/MSD recoveries outside acceptance criteria
TS1	TS1-040506-1620	05/04/06	SW-846 8270 SIM	Naphthalene	1300 D	µg/kg	MS MSD	23 23	%	J	Low	Datum is estimated, possible low bias; MS/MSD recoveries outside acceptance criteria
TS1	TS1-040506-1620	05/04/06	SW-846 6010B	Zinc	822	mg/kg	LB	0 22 T	mg/kg	B	None	Analyte detected in associated blank; sample concentration greater than five times the blank concentration
TS1	TS1-040506-1620B	05/04/06	SW-846 8270 SIM	Naphthalene	3371 94 D	µg/kg	LB	0 09 T	µg/kg	B	None	Analyte detected in associated blank; sample concentration greater than five times the blank concentration
TS1	TS1-040506-1620B	05/04/06	SW-846 6010B	Arsenic	15 7	mg/kg	LB	0 392 T	mg/kg	B	None	Analyte detected in associated blank; sample concentration greater than five times the blank concentration
TS1	TS1-040506-1620B	05/04/06	SW9071B	Total petroleum hydrocarbons	33000	mg/kg	RPD	21 7	%	J	None	Datum is estimated, bias unknown; LCS/LCD RPD outside acceptance criterion
TS2	TS2-040506-1625	05/04/06	SW-846 6010B	Zinc	193	mg/kg	LB	0 22 T	mg/kg	B	None	Analyte detected in associated blank; sample concentration greater than five times the blank concentration
TS2	TS2-040506-1625B	05/04/06	SW-846 8270 SIM	Naphthalene	233 06 D	µg/kg	LB	0 09 T	µg/kg	B	None	Analyte detected in associated blank; sample concentration greater than five times the blank concentration

TABLE 1
DATA QUALIFIERS SUMMARY TABLE
DEMONSTRATION TESTING AND FULL-SCALE OPERATION OF THE BIOGENESIS SEDIMENT DECONTAMINATION PROCESS, KEASBEY, NEW JERSEY
(Page 187 of 188)

Location Identification	Sample Identification	Sample Date	Analysis	Analyte	Sample Result	Sample Units	QC Type	QC Result	QC Units	Qualifier	Bias	Comment
TS2	TS2-040506-1625B	05/04/06	SW-846 6010B	Arsenic	5.21	mg/kg	LB	0.392 T	mg/kg	B	None	Analyte detected in associated blank; sample concentration greater than five times the blank concentration
TS2	TS2-040506-1625B	05/04/06	SW9071B	Total petroleum hydrocarbons	3200	mg/kg	MSD RPD	140 21.7	%	J	High	Datum is estimated, possible high bias; MSD recovery and LCS/LCSD RPD outside acceptance criteria
TS3	TS3-040506-1630	05/04/06	SW-846 6010B	Zinc	371	mg/kg	LB	0.22 T	mg/kg	B	None	Analyte detected in associated blank; sample concentration greater than five times the blank concentration
TS3	TS3-040506-1630B	05/04/06	SW-846 8270 SIM	Naphthalene	722.18 D	µg/kg	LB	0.09 T	µg/kg	B	None	Analyte detected in associated blank; sample concentration greater than five times the blank concentration
TS3	TS3-040506-1630B	05/04/06	SW-846 6010B	Arsenic	9.15	mg/kg	LB	0.392 T	mg/kg	B	None	Analyte detected in associated blank; sample concentration greater than five times the blank concentration
TS3	TS3-040506-1630B	05/04/06	SW9071B	Total petroleum hydrocarbons	3600	mg/kg	RPD	21.7	%	J	None	Datum is estimated, bias unknown; LCS/LCD RPD outside acceptance criterion
WS	WS-040506-1640	05/04/06	SW-846 6010B	Zinc	1230	mg/kg	LB	0.22 T	mg/kg	B	None	Analyte detected in associated blank; sample concentration greater than five times the blank concentration
WS	WS-040506-1640B	05/04/06	SW-846 8270 SIM	Naphthalene	385.34 D	µg/kg	LB	0.09 T	µg/kg	B	None	Analyte detected in associated blank; sample concentration greater than five times the blank concentration
WS	WS-040506-1640B	05/04/06	SW-846 6010B	Arsenic	30.2	mg/kg	LB	0.392 T	mg/kg	B	None	Analyte detected in associated blank; sample concentration greater than five times the blank concentration
WS	WS-040506-1640B	05/04/06	SW9071B	Total petroleum hydrocarbons	4600	mg/kg	RPD	21.7	%	J	None	Datum is estimated, bias unknown; LCS/LCD RPD outside acceptance criterion

µg/kg micrograms per kilogram
mg/kg milligrams per kilogram
pg/g picograms per gram
CCB Continuing calibration blank
CMC Comaximization criteria
CONF Confirmation column
CVS Calibration verification standard
Dup Duplicate
HT Holding time
IAR Ion abundance ration
IS Internal standard
LCS Laboratory control sample
LCSD Laboratory control sample duplicate
LB Laboratory blank
MS Matrix spike sample
MSD Matrix spike duplicate sample

TABLE 1

DATA QUALIFIERS SUMMARY TABLE
DEMONSTRATION TESTING AND FULL-SCALE OPERATION OF THE BIOGENESIS SEDIMENT DECONTAMINATION PROCESS, KEASBEY, NEW JERSEY
 (Page 188 of 188)

Location Identification	Sample Identification	Sample Date	Analysis	Analyte	Sample Result	Sample Units	QC Type	QC Result	QC Units	Qualifier	Bias	Comment
N/A	Not applicable											
PDE	Polychlorinated diphenyl ether											
%RSD	Percent relative standard deviation											
RANGE	Calibration range											
RPD	Relative percent difference											
RRF	Relative response factor											
RT	Retention time											
SLD	Serial dilution											
TUNE	Instrument tune											
D	Sample dilution required for analysis; reported values reflect the dilution											
T	Analyte was positively identified but the reported concentration is estimated; reported concentration is less than the reporting limit, but greater than the method detection limit											

TABLE 2

**SUMMARY OF NON-CONFORMING QUALITY CONTROL DATA NOT AFFECTING DATA QUALITY
 DEMONSTRATION TESTING AND FULL-SCALE OPERATION OF THE BIOGENESIS SEDIMENT DECONTAMINATION PROCESS, KEASBEY, NEW JERSEY
 (Page 1 of 31)**

Location Identification	Sample Identification/ (QC Sample)	Sample Date	Analysis	Analyte	Sample Result	Sample Units	QC Type	QC Result	QC Units	QC Limit(s)	Bias	Comment
RS	RS-211205-1000 (ICAL-010706-0531)	12/21/05	SW-846 8270C	Hexachlorocyclopentadiene	<2200	µg/kg	ICAL	31 59	%	<30	None	ICAL %RSD outside acceptance criterion and RRFs within acceptance criteria; without low standard, recalculated RSD within acceptance criteria at 23 84% Analyte not detected in associated samples
TS	TS-211205-1715	12/21/05	SW-846 8082	2,2',3,4,4',5,5'-Heptachlorobiphenyl	<1 2 D	µg/kg	MS	154	%	45-150	High	MS recovery above acceptance criteria; indicating a high bias Analyte not detected in parent sample
TS	TS-211205-1715	12/21/05	SW-846 8082	2,2',5-Trichlorobiphenyl	<1 2 D	µg/kg	MS	264	%	45-150	High	MS/MSD recoveries outside acceptance criteria; analyte not detected in parent sample
WS	WS-190106-1602	01/19/06	SW-846 8082	2,2',3,3',4,4',5,5',6-Nonachlorobiphenyl	4 3 TD	µg/kg	MS	0	%	45-150	None	MS/MSD not recovered due to sample dilution
				2,2',3,3',4,4',5-Heptachlorobiphenyl	15 D		MSD	0				
				2,2',3,4,4',5,5'-Heptachlorobiphenyl	15 D							
				2,2',3,4',5,5',6-Heptachlorobiphenyl	18 D							
				2,2',3,4,5'-Pentachlorobiphenyl	15 D							
				2,2',4,4',5,5'-Hexachlorobiphenyl	32 D							
				2,2',4,5,5'-Pentachlorobiphenyl	34 D							
				2,2',5,5'-Tetrachlorobiphenyl	63 D							
				2,2',5-Trichlorobiphenyl	62 D							
				2,3',4,4'-Tetrachlorobiphenyl	57 D							
WS	WS-190106-1602	01/19/06	SW-846 8081A	Aldrin	<65 D	µg/kg	MS	0	%	33-122	None	MS/MSD not recovered due to sample dilution
				Dieldrin	42 TD		MSD	0		33-133		
				Endrin	28 TD					33-138		
				Gamma BHC (Lindane)	<65 D					33-130		
				Heptachlor	<65 D					32-128		
				p,p'-DDT	67 D					23-144		
RS	RS-240106-1530	01/24/06	SW-846 6010B	Chromium, total	204	mg/kg	MS	287	%	75-125	None	Sample concentration greater than four times the spike amount
							MSD	275				
RS	RS-240106-1530	01/24/06	SW-846 6010B	Zinc	755	mg/kg	MS	988	%	75-125	None	Sample concentration greater than four times the spike amount
							MSD	947				
TS	TS-240106-1630	01/24/06	SW-846 8082	2,2',3,3',4,4',5,5',6-Nonachlorobiphenyl	5 1 D	µg/kg	MS	0	%	45-150	None	MS/MSD not recovered due to sample dilution
				2,2',3,3',4,4',5-Heptachlorobiphenyl	15 D		MSD	0				
				2,2',3,4,4',5,5'-Heptachlorobiphenyl	18 D							
				2,2',3,4',5,5',6-Heptachlorobiphenyl	18 D							
				2,2',3,4,5'-Pentachlorobiphenyl	15 D							
				2,2',4,5,5'-Pentachlorobiphenyl	38 D							
				2,2',5,5'-Tetrachlorobiphenyl	58 D							
				2,2',5-Trichlorobiphenyl	56 D							
				2,3',4,4'-Tetrachlorobiphenyl	57 D							

TABLE 2

**SUMMARY OF NON-CONFORMING QUALITY CONTROL DATA NOT AFFECTING DATA QUALITY
DEMONSTRATION TESTING AND FULL-SCALE OPERATION OF THE BIOGENESIS SEDIMENT DECONTAMINATION PROCESS, KEASBEY, NEW JERSEY
(Page 2 of 31)**

Location Identification	Sample Identification/ (QC Sample)	Sample Date	Analysis	Analyte	Sample Result	Sample Units	QC Type	QC Result	QC Units	QC Limit(s)	Bias	Comment
TS	TS-240106-1630	01/24/06	SW-846 8082	2,2',3,3',4,4',5-Heptachlorobiphenyl 2,2',3,4,4',5,5'-Heptachlorobiphenyl 2,2',3,4',5,5',6-Heptachlorobiphenyl 2,2',3,4,5,5'-Pentachlorobiphenyl 2,2',4,5,5'-Pentachlorobiphenyl 2,2',5,5'-Tetrachlorobiphenyl 2,2',5-Trichlorobiphenyl 2,3',4,4'-Tetrachlorobiphenyl	15 D 18 D 18 D 15 D 38 D 58 D 56 D 57 D	µg/kg	MS MSD	0 0	%	45-150	None	MS/MSD not recovered due to sample dilution
TS	TS-240106-1630	01/24/06	SW-846 8081A	Aldrin Dieldrin Endrin Gamma BHC (Lindane) Heptachlor p,p'-DDT	6.7 TD 7.1 TD 4.5 TD <14 D <14 D 82 D	µg/kg	MS MSD	0 0	%	33-122 33-133 33-138 33-130 32-128 23-144	None	MS/MSD not recovered due to sample dilution
TS	TS-240106-1630	01/24/06	SW-846 7471A	Mercury	2.4	mg/kg	MS MSD	2.53 2.43	%	75-125	None	Sample concentration greater than four times the spike amount
TS	TS-240106-1630	01/24/06	SW-846 8270C	Naphthalene	<5200 D	µg/kg	MSD	123	%	46-115	High	MSD recovery above acceptance criterion; indicating a high bias. Analyte not detected parent sample
RS	RS-270106-1400	01/27/06	SW-846 8082	2,2',3,3',4,4',5,5',6-Nonachlorobiphenyl 2,2',3,3',4,4',5-Heptachlorobiphenyl 2,2',3,4,4',5,5'-Heptachlorobiphenyl 2,2',3,4',5,5',6-Heptachlorobiphenyl 2,2',3,4,5,5'-Pentachlorobiphenyl 2,2',4,5,5'-Pentachlorobiphenyl 2,2',5,5'-Tetrachlorobiphenyl 2,2',5-Trichlorobiphenyl 2,3',4,4'-Tetrachlorobiphenyl	8.5 D 14 D 17 D 21 D 10 D 27 D 40 D 42 D 41 D	µg/kg	MS MSD	0 0	%	45-150	None	MS/MSD not recovered due to sample dilution
RS	RS-270106-1400	01/27/06	SW-846 6010B	Chromium, total	158	mg/kg	MS MSD	175 193	%	75-125	None	Sample concentration greater than four times the spike amount
RS	RS-270106-1400	01/27/06	SW-846 6010B	Lead	320	mg/kg	MS MSD	368 401	%	75-125	None	Sample concentration greater than four times the spike amount
RS	RS-270106-1400	01/27/06	SW-846 7471A	Mercury	3.7	mg/kg	MS MSD	4.33 4.03	%	75-125	None	Sample concentration greater than four times the spike amount
RS	RS-270106-1400	01/27/06	SW-846 6010B	Zinc	596	mg/kg	MS MSD	624 685	%	75-125	None	Sample concentration greater than four times the spike amount
RS	RS-300106-1700	01/30/06	SW-846 7471A	Mercury	2.1	mg/kg	MS MSD	2.67 2.55	%	75-125	None	Sample concentration greater than four times the spike amount
RS	RS-300106-1700	01/30/06	SW-846 8270C	Pentachlorophenol	<8600	µg/kg	LCS	128	%	13-127	High	LCS recovery acceptance criteria, indicating a possible high bias; analyte not detected in any associated sample

TABLE 2

**SUMMARY OF NON-CONFORMING QUALITY CONTROL DATA NOT AFFECTING DATA QUALITY
DEMONSTRATION TESTING AND FULL-SCALE OPERATION OF THE BIOGENESIS SEDIMENT DECONTAMINATION PROCESS, KEASBEY, NEW JERSEY
(Page 3 of 31)**

Location Identification	Sample Identification/ (QC Sample)	Sample Date	Analysis	Analyte	Sample Result	Sample Units	QC Type	QC Result	QC Units	QC Limit(s)	Bias	Comment
WS2	WS2-300106-1702	01/30/06	SW-846 8270C	Pentachlorophenol	<7700 D	µg/kg	LCS	128	%	13-127	High	LCS recovery acceptance criteria, indicating a possible high bias; analyte not detected in any associated sample
RS	RS-310106-1700	01/31/06	SW-846 8270C	Pentachlorophenol	<9300	µg/kg	LCS	128	%	13-127	High	LCS recovery acceptance criteria, indicating a possible high bias; analyte not detected in any associated sample
TS	TS-310106-1701	01/31/06	SW-846 8270C	Pentachlorophenol	<2600	µg/kg	LCS	128	%	13-127	High	LCS recovery acceptance criteria, indicating a possible high bias; analyte not detected in any associated sample
WS	WS-310106-1702	01/31/06	SW-846 8081A	Aldrin Dieldrin Endrin Gamma BHC (Lindane) Heptachlor p,p'-DDT	<28 D <28 D <28 D <28 D <28 D <28 D	µg/kg	MS MSD	0 0	%	33-122 33-133 33-138 33-130 32-128 23-144	None	MS/MSD not recovered due to sample dilution
WS	WS-310106-1702	01/31/06	SW-846 8270C	Pentachlorophenol	<5300	µg/kg	LCS	128	%	13-127	High	LCS recovery acceptance criteria, indicating a possible high bias; analyte not detected in any associated sample
WS	WS-010206-1602	02/01/06	SW-846 8082	2,2',3,3',4,4',5,5',6-Nonachlorobiphenyl 2,2',3,3',4,4',5-Heptachlorobiphenyl 2,2',3,4,4',5,5'-Heptachlorobiphenyl 2,2',3,4',5,5',6-Heptachlorobiphenyl 2,2',3,4,5'-Pentachlorobiphenyl 2,2',4,4',5,5'-Hexachlorobiphenyl 2,2',4,5,5'-Pentachlorobiphenyl 2,2',5,5'-Tetrachlorobiphenyl 2,2',5-Trichlorobiphenyl 2,3',4,4'-Tetrachlorobiphenyl	<4 8 D 6 7 D 8 D 8 2 D 6 D 15 D 13 D 30 D 31 D 30 D	µg/kg	MS MSD	0 0	%	45-150	None	MS/MSD not recovered due to sample dilution
WS	WS-010206-1602	02/01/06	SW-846 8270C	2,4,6-Trichlorophenol	<930	µg/kg	MS MSD	142 153	%	50-115	High	MS/MSD recoveries outside acceptance criteria; analyte not detected in parent sample
WS	WS-010206-1602	02/01/06	SW-846 8081A	Aldrin Dieldrin Endrin Gamma BHC (Lindane) Heptachlor p,p'-DDT	<24 D 3 3 TD <24 D <24 D <24 D <24 D	µg/kg	MS MSD	0 0	%	33-122 33-133 33-138 33-130 32-128 23-144	None	MS/MSD not recovered due to sample dilution
RS	RS-030206-1200 (CVS-020906-2226)	02/03/06	SW-846 8082	2,2',3,3',4,4',5,5',6-Nonachlorobiphenyl	<4 7	µg/kg	CVS	31 7	%	<25	None	CVS %D outside acceptance criterion, indicating an unknown bias Analyte not detected in associated samples
TS	TS-030206-1201 (CVS-020906-2226)	02/03/06	SW-846 8082	2,2',3,3',4,4',5,5',6-Nonachlorobiphenyl	<2 7	µg/kg	CVS	31 7	%	<25	None	CVS %D outside acceptance criterion, indicating an unknown bias Analyte not detected in associated samples

TABLE 2

**SUMMARY OF NON-CONFORMING QUALITY CONTROL DATA NOT AFFECTING DATA QUALITY
DEMONSTRATION TESTING AND FULL-SCALE OPERATION OF THE BIOGENESIS SEDIMENT DECONTAMINATION PROCESS, KEASBEY, NEW JERSEY
(Page 4 of 31)**

Location Identification	Sample Identification/ (QC Sample)	Sample Date	Analysis	Analyte	Sample Result	Sample Units	QC Type	QC Result	QC Units	QC Limit(s)	Bias	Comment
WS	WS-030206-1202	02/03/06	SW-846 8082	2,2',3,3',4,4',5,5',6-Nonachlorobiphenyl 2,2',3,3',4,4',5-Heptachlorobiphenyl 2,2',3,4,4',5,5',6-Heptachlorobiphenyl 2,2',3,4,4',5,5',6-Heptachlorobiphenyl 2,2',3,4,5'-Pentachlorobiphenyl 2,2',4,4',5,5'-Hexachlorobiphenyl 2,2',4,5,5'-Pentachlorobiphenyl 2,2',5,5'-Tetrachlorobiphenyl 2,2',5-Trichlorobiphenyl 2,3',4,4'-Tetrachlorobiphenyl	<6 1 D <6 1 D 2 3 TD 2 1 TD 3 5 TD 5 2 TD <6 1 D 17 D 10 D <6 1 D	µg/kg	MS MSD	0 0	%	45-150	None	MS/MSD not recovered due to sample dilution
WS	WS-030206-1202	02/03/06	SW-846 8270C	2,4,6-Trichlorophenol	<1200	µg/kg	MSD	125	%	50-115	High	MSD recovery above acceptance criterion; indicating a high bias Analyte not detected parent sample
WS	WS-030206-1202	02/03/06	SW-846 8081A	Aldrin Dieldrin Endrin Gamma BHC (Lindane) Heptachlor p,p'-DDT	<31 D <31 D <31 D <31 D <31 D 3 6 TD	µg/kg	MS MSD	0 0	%	33-122 33-133 33-138 33-130 32-128 23-144	None	MS/MSD not recovered due to sample dilution
WS	WS-030206-1202 (CVS-020906-2226)	02/03/06	SW-846 8082	2,2',3,3',4,4',5,5',6-Nonachlorobiphenyl	<6 1	µg/kg	CVS	31.7	%	<25	None	CVS %D outside acceptance criterion, indicating an unknown bias Analyte not detected in associated samples
RS	RS-060206-1930	02/06/06	SW-846 8290	1,2,3,7,8,9-Hexachlorodibenzofuran	<25	pg/g	LB	0.15 T	pg/g	<5	None	Analyte detected in associated blank; analyte not detected in any associated samples
WS	WS-060206-1932	02/06/06	SW-846 8082	2,2',3,3',4,4',5,5',6-Nonachlorobiphenyl 2,2',3,3',4,4',5-Heptachlorobiphenyl 2,2',3,4,4',5,5',6-Heptachlorobiphenyl 2,2',3,4,4',5,5',6-Heptachlorobiphenyl 2,2',3,4,5'-Pentachlorobiphenyl 2,2',4,4',5,5'-Hexachlorobiphenyl 2,2',4,5,5'-Pentachlorobiphenyl 2,2',5,5'-Tetrachlorobiphenyl 2,2',5-Trichlorobiphenyl 2,3',4,4'-Tetrachlorobiphenyl	<5 8 D <5 8 D 3 TD 2 4 TD 3 9 TD <5 8 D 9 9 D 19 D 12 D 18 D	µg/kg	MS MSD	0 0	%	45-150	None	MS/MSD not recovered due to sample dilution
RS	RS-070206-1630	02/07/06	SW-846 7471A	Mercury	1.3	mg/kg	MS MSD	1.35 1.48	%	75-125	None	Sample concentration greater than four times the spike amount
TS	TS-070206-1631 DRIED	02/07/06	SW-846 8290	1,2,3,7,8,9-Hexachlorodibenzofuran	<6.5	%	LB	0.33 T	pg/g	<5	None	Analyte detected in associated blank; analyte not detected in any associated samples
RS	RS-080206-1700	02/08/06	SW-846 7471A	Mercury	1.3	mg/kg	MS MSD	1.58 1.64	%	75-125	None	Sample concentration greater than four times the spike amount
WS	WS-080206-1702	02/08/06	SW-846 8082	2,2',4,4',5,5'-Hexachlorobiphenyl	<3.0 D	µg/kg	MSD	164	%	45-150	High	MSD recovery above acceptance criterion; indicating a high bias Analyte not detected parent sample

TABLE 2

**SUMMARY OF NON-CONFORMING QUALITY CONTROL DATA NOT AFFECTING DATA QUALITY
 DEMONSTRATION TESTING AND FULL-SCALE OPERATION OF THE BIOGENESIS SEDIMENT DECONTAMINATION PROCESS, KEASBEY, NEW JERSEY
 (Page 5 of 31)**

Location Identification	Sample Identification/ (QC Sample)	Sample Date	Analysis	Analyte	Sample Result	Sample Units	QC Type	QC Result	QC Units	QC Limit(s)	Bias	Comment
WS	WS-080206-1702	02/08/06	SW-846 8082	2,2',4,5,5'-Pentachlorobiphenyl	<3 0 D	µg/kg	MS MSD	210 168	%	45-150	High	MS/MSD recoveries outside acceptance criteria; analyte not detected in parent sample
RS	RS-090206-2300	02/09/06	SW-846 6010B	Chromium, total	150	mg/kg	MS MSD	187 200	%	75-125	None	Sample concentration greater than four times the spike amount
RS	RS-090206-2300	02/09/06	SW-846 6010B	Zinc	338	mg/kg	MS MSD	437 431	%	75-125	None	Sample concentration greater than four times the spike amount
RS	RS-130206-1700 (ICV-021706-1548)	02/13/06	SW-846 8082	2,2',3,3',4,4',5,5',6-Nonachlorobiphenyl	<7 0	µg/kg	CVS	-15 7	%	<15	None	CVS %D outside acceptance criterion, indicating an unknown bias Analyte not detected in associated samples
TS	TS-130206-1701	02/13/06	SW-846 8082	2,2',3,3',4,4',5,5',6-Nonachlorobiphenyl 2,2',3,3',4,4',5-Heptachlorobiphenyl 2,2',3,4,4',5,5'-Heptachlorobiphenyl 2,2',3,4',5,5',6-Heptachlorobiphenyl 2,2',3,4,5'-Pentachlorobiphenyl 2,2',4,4',5,5'-Hexachlorobiphenyl 2,2',4,5,5'-Pentachlorobiphenyl 2,2',5,5'-Tetrachlorobiphenyl 2,2',5-Trichlorobiphenyl 2,3',4,4'-Tetrachlorobiphenyl	<2 2 D 7 6 D 8 D 8 5 D 7 6 D <2 2 D 17 D 36 D 33 D 28 D	µg/kg	MS MSD	0 0	%	45-150	None	MS/MSD not recovered due to sample dilution
TS	TS-130206-1701	02/13/06	SW-846 8081A	Aldrin Dieldrin Endrin Gamma BHC (Lindane) Heptachlor p,p'-DDT	5 5 TD 7 1 TD 9 6 TD <11 D <11 D 110 D	µg/kg	MS MSD	0 0	%	33-122 33-133 33-138 33-130 32-128 23-144	None	MS/MSD not recovered due to sample dilution
TS	TS-130206-1701	02/13/06	SW-846 6010B	Chromium, total	52 5	mg/kg	MS MSD	64 67 4	%	75-125	None	Sample concentration greater than four times the spike amount
TS	TS-130206-1701	02/13/06	SW-846 6010B	Zinc	200	mg/kg	MS MSD	228 246	%	75-125	None	Sample concentration greater than four times the spike amount
TS	TS-130206-1701 (ICV-021706-1548)	02/13/06	SW-846 8082	2,2',3,3',4,4',5,5',6-Nonachlorobiphenyl	<2 2	µg/kg	CVS	-15 7	%	<15	None	CVS %D outside acceptance criterion, indicating an unknown bias Analyte not detected in associated samples
WS	WS-130206-1702 (ICV-021706-1548)	02/13/06	SW-846 8082	2,2',3,3',4,4',5,5',6-Nonachlorobiphenyl	<7 0	µg/kg	CVS	-15 7	%	<15	None	CVS %D outside acceptance criterion, indicating an unknown bias Analyte not detected in associated samples
RS	RS-140206-1330	02/14/06	SW-846 6010B	Zinc	493	mg/kg	MS MSD	595 557	%	75-125	None	Sample concentration greater than four times the spike amount

TABLE 2

**SUMMARY OF NON-CONFORMING QUALITY CONTROL DATA NOT AFFECTING DATA QUALITY
DEMONSTRATION TESTING AND FULL-SCALE OPERATION OF THE BIOGENESIS SEDIMENT DECONTAMINATION PROCESS, KEASBEY, NEW JERSEY
(Page 6 of 31)**

Location Identification	Sample Identification/ (QC Sample)	Sample Date	Analysis	Analyte	Sample Result	Sample Units	QC Type	QC Result	QC Units	QC Limit(s)	Bias	Comment
TS	TS-140206-1331	02/14/06	SW-846 8082	2,2',3,3',4,4',5,5',6-Nonachlorobiphenyl 2,2',3,3',4,4',5-Heptachlorobiphenyl 2,2',3,4,4',5,5'-Heptachlorobiphenyl 2,2',3,4',5,5',6-Heptachlorobiphenyl 2,2',3,4,5'-Pentachlorobiphenyl 2,2',4,4',5,5'-Hexachlorobiphenyl 2,2',4,5,5'-Pentachlorobiphenyl 2,2',5,5'-Tetrachlorobiphenyl 2,2',5-Trichlorobiphenyl 2,3',4,4'-Tetrachlorobiphenyl	3 4 D 11 D 9 8 D 10 D 7 3 D <2 3 D <2 3 D 20 D 26 D 25 D	µg/kg	MS MSD	0 0	%	45-150	None	MS/MSD not recovered due to sample dilution
TS	TS-140206-1331	02/14/06	SW-846 8081A	Aldrin Dieldrin Endrin Gamma BHC (Lindane) Heptachlor p,p'-DDT	7 3 TD 4 6 TD 6 7 TD <11 D <11 D 200 D	µg/kg	MS MSD	0 0	%	33-122 33-133 33-138 33-130 32-128 23-144	None	MS/MSD not recovered due to sample dilution
TS	TS-160206-1501	02/16/06	SW-846 8082	2,2',3,3',4,4',5,5',6-Nonachlorobiphenyl 2,2',3,3',4,4',5-Heptachlorobiphenyl 2,2',3,4,4',5,5'-Heptachlorobiphenyl 2,2',3,4',5,5',6-Heptachlorobiphenyl 2,2',3,4,5'-Pentachlorobiphenyl 2,2',4,4',5,5'-Hexachlorobiphenyl 2,2',4,5,5'-Pentachlorobiphenyl 2,2',5,5'-Tetrachlorobiphenyl 2,2',5-Trichlorobiphenyl 2,3',4,4'-Tetrachlorobiphenyl	13 D 5 9 D 5 4 D 6 D 6 5 D 13 D 8 2 D 18 D 18 D 21 D	µg/kg	MS MSD	0 0	%	45-150	None	MS/MSD not recovered due to sample dilution
TS	TS-160206-1501	02/16/06	SW-846 8081A	Aldrin Dieldrin Endrin Gamma BHC (Lindane) Heptachlor p,p'-DDT	<13 D 5 4 TD 2 7 TD <13 D <13 D 240 D	µg/kg	MS MSD	0 0	%	33-122 33-133 33-138 33-130 32-128 23-144	None	MS/MSD not recovered due to sample dilution
RS	RS-170206-1100	02/17/06	SW-846 6010B	Chromium, total	270	mg/kg	MS MSD	306 270	%	75-125	None	Sample concentration greater than four times the spike amount
RS	RS-170206-1100	02/17/06	SW-846 6010B	Zinc	629	mg/kg	MS MSD	730 646	%	75-125	None	Sample concentration greater than four times the spike amount
RS	RS-170206-1100	02/17/06	SW-846 8270C	2,4,5-Trichlorophenol	<3600 D	µg/kg	RPD	30 1	%	30	None	LCS/LCD RPD outside acceptance criterion; analyte not detected in associated sample
RS	RS-170206-1100	02/17/06	SW-846 8270C	2,4,6-Trichlorophenol	<3600 D	µg/kg	RPD	40 9	%	29	None	LCS/LCD RPD outside acceptance criterion; analyte not detected in associated sample

TABLE 2
SUMMARY OF NON-CONFORMING QUALITY CONTROL DATA NOT AFFECTING DATA QUALITY
DEMONSTRATION TESTING AND FULL-SCALE OPERATION OF THE BIOGENESIS SEDIMENT DECONTAMINATION PROCESS , KEASBEY, NEW JERSEY
(Page 7 of 31)

Location Identification	Sample Identification/ (QC Sample)	Sample Date	Analysis	Analyte	Sample Result	Sample Units	QC Type	QC Result	QC Units	QC Limit(s)	Bias	Comment
RS	RS-170206-1100	02/17/06	SW-846 8270C	2-Methylphenol (o-Cresol)	<3600 D	µg/kg	RPD	30.2	%	29	None	LCS/LCD RPD outside acceptance criterion; analyte not detected in associated sample
RS	RS-170206-1100	02/17/06	SW-846 8270C	Hexachlorobenzene	<3600 D	µg/kg	RPD	42.7	%	29	None	LCS/LCD RPD outside acceptance criterion; analyte not detected in associated sample
RS	RS-170206-1100	02/17/06	SW-846 8270C	Hexachlorobutadiene	<3600 D	µg/kg	RPD	28.6	%	25	None	LCS/LCD RPD outside acceptance criterion; analyte not detected in associated sample
RS	RS-170206-1100	02/17/06	SW-846 8270C	Pentachlorophenol	<17000 D	µg/kg	RPD	70.2	%	49	None	LCS/LCD RPD outside acceptance criterion; analyte not detected in associated sample
TS	TS-170206-1101	02/17/06	SW-846 8270C	2,4,5-Trichlorophenol	<1100 D	µg/kg	RPD	30.1	%	30	None	LCS/LCD RPD outside acceptance criterion; analyte not detected in associated sample
TS	TS-170206-1101	02/17/06	SW-846 8270C	2,4,6-Trichlorophenol	<1100 D	µg/kg	RPD	40.9	%	29	None	LCS/LCD RPD outside acceptance criterion; analyte not detected in associated sample
TS	TS-170206-1101	02/17/06	SW-846 8270C	2-Methylphenol (o-Cresol)	<1100 D	µg/kg	RPD	30.2	%	29	None	LCS/LCD RPD outside acceptance criterion; analyte not detected in associated sample
TS	TS-170206-1101	02/17/06	SW-846 8270C	Hexachlorobenzene	<1100 D	µg/kg	RPD	42.7	%	29	None	LCS/LCD RPD outside acceptance criterion; analyte not detected in associated sample
TS	TS-170206-1101	02/17/06	SW-846 8270C	Hexachlorobutadiene	<1100 D	µg/kg	RPD	28.6	%	25	None	LCS/LCD RPD outside acceptance criterion; analyte not detected in associated sample
TS	TS-170206-1101	02/17/06	SW-846 8270C	Pentachlorophenol	<5600 D	µg/kg	RPD	70.2	%	49	None	LCS/LCD RPD outside acceptance criterion; analyte not detected in associated sample
WS	WS-170206-1102	02/17/06	SW-846 8082	2,2',3,3',4,4',5,5',6-Nonachlorobiphenyl 2,2',3,3',4,4',5-Heptachlorobiphenyl 2,2',3,4,4',5,5'-Heptachlorobiphenyl 2,2',3,4',5,5',6-Heptachlorobiphenyl 2,2',3,4,5'-Pentachlorobiphenyl 2,2',4,4',5,5'-Hexachlorobiphenyl 2,2',4,5,5'-Pentachlorobiphenyl 2,2',5,5'-Tetrachlorobiphenyl 2,2',5-Trichlorobiphenyl 2,3',4,4'-Tetrachlorobiphenyl	4.4 TD 7.6 D 9 D 10 D 9.9 D 17 D 22 D 30 D 34 D 35 D	µg/kg	MS MSD	0 0	%	45-150	None	MS/MSD not recovered due to sample dilution
WS	WS-170206-1102	02/17/06	SW-846 8270C	2,4,6-Trichlorophenol	<2700 D	µg/kg	MS	121	%	50-115	High	MS recovery above acceptance criteria; indicating a high bias. Analyte not detected in parent sample

TABLE 2

**SUMMARY OF NON-CONFORMING QUALITY CONTROL DATA NOT AFFECTING DATA QUALITY
DEMONSTRATION TESTING AND FULL-SCALE OPERATION OF THE BIOGENESIS SEDIMENT DECONTAMINATION PROCESS, KEASBEY, NEW JERSEY
(Page 8 of 31)**

Location Identification	Sample Identification/ (QC Sample)	Sample Date	Analysis	Analyte	Sample Result	Sample Units	QC Type	QC Result	QC Units	QC Limit(s)	Bias	Comment
WS	WS-170206-1102	02/17/06	SW-846 8081A	Aldrin Dieldrin Endrin Gamma BHC (Lindane) Heptachlor p,p'-DDT	5.6 TD 3.7 TD <35 D <35 D <35 D 15 TD	µg/kg	MS MSD	0 0	%	33-122 33-133 33-138 33-130 32-128 23-144	None	MS/MSD not recovered due to sample dilution
WS	WS-170206-1102	02/17/06	SW-846 6010B	Chromium, total	423	mg/kg	MS MSD	452 467	%	75-125	None	Sample concentration greater than four times the spike amount
WS	WS-170206-1102	02/17/06	SW-846 6010B	Lead	506	mg/kg	MS MSD	587 603	%	75-125	None	Sample concentration greater than four times the spike amount
WS	WS-170206-1102	02/17/06	SW-846 6010B	Zinc	803	mg/kg	MS MSD	870 898	%	75-125	None	Sample concentration greater than four times the spike amount
TS	TS-230206-0930	02/23/06	SW-846 8290	1,2,3,7,8,9-Hexachlorodibenzofuran	<7.0	%	LB	0.33 T	pg/g	<5	None	Analyte detected in associated blank; analyte not detected in any associated samples
TS	TS-230206-0930	02/23/06	SW-846 8082	2,2',3,3',4,4',5,5'-Nonachlorobiphenyl 2,2',3,3',4,4',5,5'-Heptachlorobiphenyl 2,2',3,4,4',5,5'-Heptachlorobiphenyl 2,2',3,4',5,5',6-Heptachlorobiphenyl 2,2',3,4,5,5'-Pentachlorobiphenyl 2,2',4,4',5,5'-Hexachlorobiphenyl 2,2',4,5,5'-Pentachlorobiphenyl 2,2',5,5'-Tetrachlorobiphenyl 2,2',5-Trichlorobiphenyl 2,3',4,4'-Tetrachlorobiphenyl	2.7 D 4.4 D 4.9 D 5.4 D 6 D <2.4 D 12 D 15 D 19 D 20 D	µg/kg	MS MSD	0 0	%	45-150	None	MS/MSD not recovered due to sample dilution
TS	TS-230206-0930	02/23/06	SW-846 8081A	Aldrin Dieldrin Endrin Gamma BHC (Lindane) Heptachlor p,p'-DDT	<12 D 5.3 TD <12 D <12 D <12 D 300 D	µg/kg	MS MSD	0 0	%	33-122 33-133 33-138 33-130 32-128 23-144	None	MS/MSD not recovered due to sample dilution
TS	TS-230206-0930	02/23/06	SW-846 6010B	Chromium, total	69	mg/kg	MS MSD	74.4 74	%	75-125	None	Sample concentration greater than four times the spike amount
TS	TS-230206-0930	02/23/06	SW-846 6010B	Lead	145	mg/kg	MS MSD	184 172	%	75-125	None	Sample concentration greater than four times the spike amount
TS	TS-230206-0930	02/23/06	SW-846 6010B	Zinc	212	mg/kg	MS MSD	237 227	%	75-125	None	Sample concentration greater than four times the spike amount

TABLE 2

**SUMMARY OF NON-CONFORMING QUALITY CONTROL DATA NOT AFFECTING DATA QUALITY
 DEMONSTRATION TESTING AND FULL-SCALE OPERATION OF THE BIOGENESIS SEDIMENT DECONTAMINATION PROCESS, KEASBEY, NEW JERSEY
 (Page 9 of 31)**

Location Identification	Sample Identification/ (QC Sample)	Sample Date	Analysis	Analyte	Sample Result	Sample Units	QC Type	QC Result	QC Units	QC Limit(s)	Bias	Comment
TS	TS-230206-0930 DRIED	02/23/06	SW-846 8082	2,2',3,3',4,4',5,5',6-Nonachlorobiphenyl 2,2',3,3',4,4',5-Heptachlorobiphenyl 2,2',3,4,4',5,5'-Heptachlorobiphenyl 2,2',3,4',5,5',6-Heptachlorobiphenyl 2,2',3,4,5'-Pentachlorobiphenyl 2,2',4,4',5,5'-Hexachlorobiphenyl 2,2',4,5,5'-Pentachlorobiphenyl 2,2',5,5'-Tetrachlorobiphenyl 2,2',5-Trichlorobiphenyl 2,3',4,4'-Tetrachlorobiphenyl	1.7 TD 3.3 D 3.9 D 4.5 D 3.7 D <2.5 D 11 D 13 D 16 D 15 D	µg/kg	MS MSD	0 0	%	45-150	None	MS/MSD not recovered due to sample dilution
TS	TS-230206-0930 DRIED	02/23/06	SW-846 8081A	Aldrin Dieldrin Endrin Gamma BHC (Lindane) Heptachlor p,p'-DDT	<12 D 3.9 TD <12 D <12 D <12 D 160 D	µg/kg	MS MSD	0 0	%	33-122 33-133 33-138 33-130 32-128 23-144	None	MS/MSD not recovered due to sample dilution
TS	TS-230206-0930 DRIED	02/23/06	SW-846 8290	1,2,3,7,8,9-Hexachlorodibenzofuran	<7.0	%	LB	0.33 T	pg/g	<5	None	Analyte detected in associated blank; analyte not detected in any associated samples
TS	TS-270206-1350	02/27/06	SW-846 8082	2,2',3,3',4,4',5,5',6-Nonachlorobiphenyl 2,2',3,3',4,4',5-Heptachlorobiphenyl 2,2',3,4,4',5,5'-Heptachlorobiphenyl 2,2',3,4',5,5',6-Heptachlorobiphenyl 2,2',3,4,5'-Pentachlorobiphenyl 2,2',4,4',5,5'-Hexachlorobiphenyl 2,2',4,5,5'-Pentachlorobiphenyl 2,2',5,5'-Tetrachlorobiphenyl 2,2',5-Trichlorobiphenyl 2,3',4,4'-Tetrachlorobiphenyl	2.1 TD 5.4 D 6.1 D 6.8 D 5 D 12 D 14 D 21 D 26 D 24 D	µg/kg	MS MSD	0 0	%	45-150	None	MS/MSD not recovered due to sample dilution
TS	TS-270206-1350	02/27/06	SW-846 8081A	Aldrin Dieldrin Endrin Gamma BHC (Lindane) Heptachlor p,p'-DDT	<630 D 120 TD <630 D <630 D <630 D 130 TD	µg/kg	MS MSD	0 0	%	33-122 33-133 33-138 33-130 32-128 23-144	None	MS/MSD not recovered due to sample dilution
TS	TS-270206-1350	02/27/06	SW-846 6010B	Lead	151	mg/kg	MS MSD	179 178	%	75-125	None	Sample concentration greater than four times the spike amount
TS	TS-270206-1350	02/27/06	SW-846 7471A	Mercury	3.2	mg/kg	MS MSD	2.3 3.16	%	75-125	None	Sample concentration greater than four times the spike amount
TS	TS-270206-1350	02/27/06	SW-846 6010B	Zinc	233	mg/kg	MS MSD	260 244	%	75-125	None	Sample concentration greater than four times the spike amount

TABLE 2

**SUMMARY OF NON-CONFORMING QUALITY CONTROL DATA NOT AFFECTING DATA QUALITY
 DEMONSTRATION TESTING AND FULL-SCALE OPERATION OF THE BIOGENESIS SEDIMENT DECONTAMINATION PROCESS, KEASBEY, NEW JERSEY
 (Page 10 of 31)**

Location Identification	Sample Identification/ (QC Sample)	Sample Date	Analysis	Analyte	Sample Result	Sample Units	QC Type	QC Result	QC Units	QC Limit(s)	Bias	Comment
TS	TS-270206-1350 DRIED	02/27/06	SW-846 8082	2,2',3,3',4,4',5,5',6-Nonachlorobiphenyl 2,2',3,3',4,4',5-Heptachlorobiphenyl 2,2',3,4,4',5,5'-Heptachlorobiphenyl 2,2',3,4',5,5',6-Heptachlorobiphenyl 2,2',3,4,5'-Pentachlorobiphenyl 2,2',4,4',5,5'-Hexachlorobiphenyl 2,2',4,5,5'-Pentachlorobiphenyl 2,2',5,5'-Tetrachlorobiphenyl 2,2',5-Trichlorobiphenyl 2,3',4,4'-Tetrachlorobiphenyl	2 6 D 5 1 D 6 1 D 6 6 D 5 D 13 D 13 D 19 D 22 D 21 D	µg/kg	MS MSD	0 0	%	45-150	None	MS/MSD not recovered due to sample dilution
TS	TS-270206-1350 DRIED	02/27/06	SW-846 8081A	Aldrin Dieldrin Endrin Gamma BHC (Lindane) Heptachlor p,p'-DDT	<60 D 13 TD 6 1 TD <60 D <60 D 280 D	µg/kg	MS MSD	0 0	%	33-122 33-133 33-138 33-130 32-128 23-144	None	MS/MSD not recovered due to sample dilution
TS	TS-270206-1630	02/27/06	SW-846 8082	2,2',3,3',4,4',5,5',6-Nonachlorobiphenyl 2,2',3,3',4,4',5-Heptachlorobiphenyl 2,2',3,4,4',5,5'-Heptachlorobiphenyl 2,2',3,4',5,5',6-Heptachlorobiphenyl 2,2',3,4,5'-Pentachlorobiphenyl 2,2',4,4',5,5'-Hexachlorobiphenyl 2,2',4,5,5'-Pentachlorobiphenyl 2,2',5,5'-Tetrachlorobiphenyl 2,2',5-Trichlorobiphenyl 2,3',4,4'-Tetrachlorobiphenyl	2 4 D 5 9 D 6 9 D 7 5 D 5 6 D 13 D 15 D 30 D 27 D 25 D	µg/kg	MS MSD	0 0	%	45-150	None	MS/MSD not recovered due to sample dilution
TS	TS-270206-1630	02/27/06	SW-846 8081A	Aldrin Dieldrin Endrin Gamma BHC (Lindane) Heptachlor p,p'-DDT	12 TD 16 TD 18 TD <61 D <61 D 150 D	µg/kg	MS MSD	0 0	%	33-122 33-133 33-138 33-130 32-128 23-144	None	MS/MSD not recovered due to sample dilution
TS	TS-270206-1630 DRIED	02/27/06	SW-846 8082	2,2',3,3',4,4',5,5',6-Nonachlorobiphenyl 2,2',3,3',4,4',5-Heptachlorobiphenyl 2,2',3,4,4',5,5'-Heptachlorobiphenyl 2,2',3,4',5,5',6-Heptachlorobiphenyl 2,2',3,4,5'-Pentachlorobiphenyl 2,2',4,4',5,5'-Hexachlorobiphenyl 2,2',4,5,5'-Pentachlorobiphenyl 2,2',5,5'-Tetrachlorobiphenyl 2,2',5-Trichlorobiphenyl 2,3',4,4'-Tetrachlorobiphenyl	2 6 D 6 1 D 7 2 D 7 9 D 6 D 13 D 17 D 21 D 26 D 25 D	µg/kg	MS MSD	0 0	%	45-150	None	MS/MSD not recovered due to sample dilution

TABLE 2

**SUMMARY OF NON-CONFORMING QUALITY CONTROL DATA NOT AFFECTING DATA QUALITY
 DEMONSTRATION TESTING AND FULL-SCALE OPERATION OF THE BIOGENESIS SEDIMENT DECONTAMINATION PROCESS, KEASBEY, NEW JERSEY
 (Page 11 of 31)**

Location Identification	Sample Identification/ (QC Sample)	Sample Date	Analysis	Analyte	Sample Result	Sample Units	QC Type	QC Result	QC Units	QC Limit(s)	Bias	Comment
TS	TS-270206-1630 DRIED	02/27/06	SW-846 8081A	Aldrin Dieldrin Endrin Gamma BHC (Lindane) Heptachlor p,p'-DDT	8.5 TD 15 TD 15 TD <58 D <58 D 180 D	µg/kg	MS MSD	0 0	%	33-122 33-133 33-138 33-130 32-128 23-144	None	MS/MSD not recovered due to sample dilution
RS	RS-010306-1700	03/01/06	SW-846 6010B	Chromium, total	178	mg/kg	MS MSD	222 219	%	75-125	None	Sample concentration greater than four times the spike amount
RS	RS-010306-1700	03/01/06	SW-846 7471A	Mercury	9.3	mg/kg	MS MSD	7.81 10.9	%	75-125	None	Sample concentration greater than four times the spike amount
RS	RS-010306-1700	03/01/06	SW-846 6010B	Zinc	395	mg/kg	MS MSD	487 493	%	75-125	None	Sample concentration greater than four times the spike amount
TS	TS-010306-1705	03/01/06	SW-846 8082	2,2',3,3',4,4',5,5',6-Nonachlorobiphenyl 2,2',3,3',4,4',5-Heptachlorobiphenyl 2,2',3,4,4',5,5'-Heptachlorobiphenyl 2,2',3,4',5,5',6-Heptachlorobiphenyl 2,2',3,4,5'-Pentachlorobiphenyl 2,2',4,4',5,5'-Hexachlorobiphenyl 2,2',4,5,5'-Pentachlorobiphenyl 2,2',5,5'-Tetrachlorobiphenyl 2,2',5-Trichlorobiphenyl 2,3',4,4'-Tetrachlorobiphenyl	3.7 D 6.7 D 7.9 D 8.6 D 7.8 D 16 D <2.7 D 34 D 44 D 40 D	µg/kg	MS MSD	0 0	%	45-150	None	MS/MSD not recovered due to sample dilution
TS	TS-010306-1705	03/01/06	SW-846 8081A	Aldrin Dieldrin Endrin Gamma BHC (Lindane) Heptachlor p,p'-DDT	<340 D <340 D <340 D <340 D <340 D 140 TD	µg/kg	MS MSD	0 0	%	33-122 33-133 33-138 33-130 32-128 23-144	None	MS/MSD not recovered due to sample dilution
RS	RS-020306-1700	03/02/06	SW-846 6010B	Chromium, total	222	mg/kg	MS MSD	221 261	%	75-125	None	Sample concentration greater than four times the spike amount
RS	RS-020306-1700	03/02/06	SW-846 6010B	Zinc	482	mg/kg	MS MSD	495 591	%	75-125	None	Sample concentration greater than four times the spike amount

TABLE 2

**SUMMARY OF NON-CONFORMING QUALITY CONTROL DATA NOT AFFECTING DATA QUALITY
 DEMONSTRATION TESTING AND FULL-SCALE OPERATION OF THE BIOGENESIS SEDIMENT DECONTAMINATION PROCESS, KEASBEY, NEW JERSEY
 (Page 12 of 31)**

Location Identification	Sample Identification/ (QC Sample)	Sample Date	Analysis	Analyte	Sample Result	Sample Units	QC Type	QC Result	QC Units	QC Limit(s)	Bias	Comment
WS	WS-020306-1710	03/02/06	SW-846 8082	2,2',3,3',4,4',5,5',6-Nonachlorobiphenyl 2,2',3,3',4,4',5-Heptachlorobiphenyl 2,2',3,4,4',5,5'-Heptachlorobiphenyl 2,2',3,4',5,5',6-Heptachlorobiphenyl 2,2',3,4,5'-Pentachlorobiphenyl 2,2',4,4',5,5'-Hexachlorobiphenyl 2,2',4,5,5'-Pentachlorobiphenyl 2,2',5,5'-Tetrachlorobiphenyl 2,2',5-Trichlorobiphenyl 2,3',4,4'-Tetrachlorobiphenyl	8 9 D 13 D 16 D 17 D 15 D 29 D <6 5 D 56 D 76 D 68 D	µg/kg	MS MSD	0 0	%	45-150	None	MS/MSD not recovered due to sample dilution
WS	WS-020306-1710	03/02/06	SW-846 8081A	Aldrin Dieldrin Endrin Gamma BHC (Lindane) Heptachlor p,p'-DDT	<320 D <320 D 43 TD <320 D <320 D <320 D	µg/kg	MS MSD	0 0	%	33-122 33-133 33-138 33-130 32-128 23-144	None	MS/MSD not recovered due to sample dilution
RS	RS-030306-1200	03/03/06	SW-846 6010B	Chromium, total	210	mg/kg	MS MSD	288 261	%	75-125	None	Sample concentration greater than four times the spike amount
RS	RS-030306-1200	03/03/06	SW-846 7471A	Mercury	9	mg/kg	MS MSD	8 61 8 91	%	75-125	None	Sample concentration greater than four times the spike amount
TS	TS-030306-1205	03/03/06	SW-846 8082	2,2',3,3',4,4',5,5',6-Nonachlorobiphenyl 2,2',3,3',4,4',5-Heptachlorobiphenyl 2,2',3,4,4',5,5'-Heptachlorobiphenyl 2,2',3,4',5,5',6-Heptachlorobiphenyl 2,2',3,4,5'-Pentachlorobiphenyl 2,2',4,4',5,5'-Hexachlorobiphenyl 2,2',4,5,5'-Pentachlorobiphenyl 2,2',5,5'-Tetrachlorobiphenyl 2,2',5-Trichlorobiphenyl 2,3',4,4'-Tetrachlorobiphenyl	5 2 D 4 2 D 5 D 5 6 D 5 1 D 10 D <2 9 D 20 D 29 D 22 D	µg/kg	MS MSD	0 0	%	45-150	None	MS/MSD not recovered due to sample dilution
TS	TS-030306-1205	03/03/06	SW-846 8081A	Aldrin Dieldrin Endrin Gamma BHC (Lindane) Heptachlor p,p'-DDT	<150 D <150 D 34 TD <150 D <150 D 330 D	µg/kg	MS MSD	0 0	%	33-122 33-133 33-138 33-130 32-128 23-144	None	MS/MSD not recovered due to sample dilution

TABLE 2

**SUMMARY OF NON-CONFORMING QUALITY CONTROL DATA NOT AFFECTING DATA QUALITY
 DEMONSTRATION TESTING AND FULL-SCALE OPERATION OF THE BIOGENESIS SEDIMENT DECONTAMINATION PROCESS, KEASBEY, NEW JERSEY
 (Page 13 of 31)**

Location Identification	Sample Identification/ (QC Sample)	Sample Date	Analysis	Analyte	Sample Result	Sample Units	QC Type	QC Result	QC Units	QC Limit(s)	Bias	Comment
SEC SCREEN	SEC SCREEN-INFLUENT	03/16/06	SW-846 8270 SIM	Acenaphthene	250 D	µg/kg	MS	0	%	40-115	None	MS/MSD not recovered due to sample dilution
				Acenaphthylene	570 D		MSD	0		40-115		
				Anthracene	790 D					40-115		
				Benzo(a)anthracene	2000 D					40-115		
				Benzo(a)pyrene	1900 D					40-115		
				Benzo(b)fluoranthene	2100 D					36-115		
				Benzo(g,h,i)perylene	1500 D					34-119		
				Benzo(k)fluoranthene	910 D					36-115		
				Chrysene	2400 D					40-115		
				Dibenz(a,h)anthracene	380 D					40-115		
				Fluoranthene	4200 D					40-115		
				Fluorene	290 D					40-115		
				Indeno(1,2,3-c,d)pyrene	1100 D					40-115		
				Naphthalene	210 TD					40-115		
				Phenanthrene	1500 D					40-115		
				Pyrene	3200 D					40-115		
SEC SCREEN	SEC SCREEN-INFLUENT	03/16/06	SW-846 6010B	Chromium, total	212	mg/kg	MS MSD	227 230	%	75-125	None	
SEC SCREEN	SEC SCREEN-INFLUENT	03/16/06	SW-846 7471A	Mercury	4.6	mg/kg	MS MSD	4.5 4.13	%	75-125	None	Sample concentration greater than four times the spike amount
SEC SCREEN	SEC SCREEN-INFLUENT	03/16/06	SW-846 6010B	Zinc	723	mg/kg	MS MSD	753 772	%	75-125	None	Sample concentration greater than four times the spike amount
TS1	TS1-210306-1035	03/21/06	SW-846 8270 SIM	Acenaphthene	81 D	µg/kg	MS	0	%	40-115	None	MS/MSD not recovered due to sample dilution
				Acenaphthylene	180 D		MSD	0		40-115		
				Anthracene	240 D					40-115		
				Benzo(a)anthracene	440 D					40-115		
				Benzo(a)pyrene	420 D					40-115		
				Benzo(b)fluoranthene	470 D					36-115		
				Benzo(g,h,i)perylene	340 D					34-119		
				Benzo(k)fluoranthene	200 D					36-115		
				Chrysene	450 D					40-115		
				Dibenz(a,h)anthracene	86 D					40-115		
				Fluoranthene	840 D					40-115		
				Fluorene	88 D					40-115		
				Indeno(1,2,3-c,d)pyrene	270 D					40-115		
				Naphthalene	89 D					40-115		
				Phenanthrene	410 D					40-115		
				Pyrene	860 D					40-115		

TABLE 2

**SUMMARY OF NON-CONFORMING QUALITY CONTROL DATA NOT AFFECTING DATA QUALITY
 DEMONSTRATION TESTING AND FULL-SCALE OPERATION OF THE BIOGENESIS SEDIMENT DECONTAMINATION PROCESS, KEASBEY, NEW JERSEY
 (Page 14 of 31)**

Location Identification	Sample Identification/ (QC Sample)	Sample Date	Analysis	Analyte	Sample Result	Sample Units	QC Type	QC Result	QC Units	QC Limit(s)	Bias	Comment
TS1	TS1-210306-1035-RR	03/21/06	SW-846 8270 SIM	Acenaphthene	460 D	µg/kg	MS	0	%	40-115	None	MS/MSD not recovered due to sample dilution
				Acenaphthylene	600 D		MSD	0		40-115		
				Anthracene	1200 D					40-115		
				Benzo(a)anthracene	2400 D					40-115		
				Benzo(a)pyrene	2300 D					40-115		
				Benzo(b)fluoranthene	2100 D					36-115		
				Benzo(g,h,i)perylene	2000 D					34-119		
				Benzo(k)fluoranthene	860 D					36-115		
				Chrysene	2400 D					40-115		
				Dibenz(a,h)anthracene	590 D					40-115		
				Fluoranthene	4200 D					40-115		
				Fluorene	470 D					40-115		
				Indeno(1,2,3-c,d)pyrene	1600 D					40-115		
				Naphthalene	480 D					40-115		
				Phenanthrene	2700 D					40-115		
				Pyrene	3600 D					40-115		
				TS5	TS5-210306-1135	03/21/06	SW-846 8270 SIM	Acenaphthene	740 D	µg/kg		
Acenaphthylene	810 D		MSD					0		40-115		
Anthracene	5200 D									40-115		
Benzo(a)anthracene	5300 D									40-115		
Benzo(a)pyrene	4300 D									40-115		
Benzo(b)fluoranthene	4500 D									36-115		
Benzo(g,h,i)perylene	2900 D									34-119		
Benzo(k)fluoranthene	1500 D									36-115		
Chrysene	5600 D									40-115		
Dibenz(a,h)anthracene	880 D									40-115		
Fluoranthene	7800 D									40-115		
Fluorene	680 D									40-115		
Indeno(1,2,3-c,d)pyrene	2600 D									40-115		
Naphthalene	820 D									40-115		
Phenanthrene	5100 D									40-115		
Pyrene	6500 D									40-115		
TS	TS-220306-1000	03/22/06	SW-846 6010B					Lead	175	mg/kg	MS MSD	171 306
TS	TS-220306-1000	03/22/06	SW-846 6010B	Zinc	213	mg/kg	MS MSD	237 255	%	75-125	None	Sample concentration greater than four times the spike amount

TABLE 2

**SUMMARY OF NON-CONFORMING QUALITY CONTROL DATA NOT AFFECTING DATA QUALITY
 DEMONSTRATION TESTING AND FULL-SCALE OPERATION OF THE BIOGENESIS SEDIMENT DECONTAMINATION PROCESS, KEASBEY, NEW JERSEY
 (Page 15 of 31)**

Location Identification	Sample Identification/ (QC Sample)	Sample Date	Analysis	Analyte	Sample Result	Sample Units	QC Type	QC Result	QC Units	QC Limit(s)	Bias	Comment
TS1	TS1-220306-1005	03/22/06	SW-846 8270 SIM	Acenaphthene	700 D	µg/kg	MS	0	%	40-115	None	MS/MSD not recovered due to sample dilution
				Acenaphthylene	780 D		MSD	0		40-115		
				Anthracene	1800 D					40-115		
				Benzo(a)anthracene	4100 D					40-115		
				Benzo(a)pyrene	3800 D					40-115		
				Benzo(b)fluoranthene	4200 D					36-115		
				Benzo(g,h,i)perylene	2900 D					34-119		
				Benzo(k)fluoranthene	1600 D					36-115		
				Chrysene	4100 D					40-115		
				Dibenz(a,h)anthracene	870 D					40-115		
				Fluoranthene	7100 D					40-115		
				Fluorene	680 D					40-115		
				Indeno(1,2,3-c,d)pyrene	2600 D					40-115		
				Naphthalene	880 D					40-115		
				Phenanthrene	5100 D					40-115		
				Pyrene	6500 D					40-115		
				SS2	SS2-230306-1540	03/23/06	SW-846 8270 SIM	Acenaphthene	580 D	µg/kg		
Acenaphthylene	1500 D		MSD					0		40-115		
Anthracene	2100 D									40-115		
Benzo(a)anthracene	6200 D									40-115		
Benzo(a)pyrene	5000 D									40-115		
Benzo(b)fluoranthene	4800 D									36-115		
Benzo(g,h,i)perylene	3600 D									34-119		
Benzo(k)fluoranthene	2000 D									36-115		
Chrysene	7400 D									40-115		
Dibenz(a,h)anthracene	1200 D									40-115		
Fluoranthene	8400 D									40-115		
Fluorene	710 D									40-115		
Indeno(1,2,3-c,d)pyrene	2900 D									40-115		
Naphthalene	330 TD									40-115		
Phenanthrene	3400 D									40-115		
Pyrene	6800 D									40-115		
TS	TS-230306-0930	03/23/06	SW-846 6010B					Lead	159	mg/kg	MS MSD	219 188
TS	TS-230306-0930	03/23/06	SW-846 6010B	Zinc	209	mg/kg	MS MSD	257 255	%	75-125	None	Sample concentration greater than four times the spike amount
PSS	PSS-270306-1100	03/27/06	SW-846 7471A	Mercury	5.3	mg/kg	MS MSD	3.83 4.7	%	75-125	None	Sample concentration greater than four times the spike amount
PSS	PSS-270306-1100	03/27/06	SW-846 6010B	Zinc	553	mg/kg	MS MSD	704 734	%	75-125	None	Sample concentration greater than four times the spike amount

TABLE 2

**SUMMARY OF NON-CONFORMING QUALITY CONTROL DATA NOT AFFECTING DATA QUALITY
 DEMONSTRATION TESTING AND FULL-SCALE OPERATION OF THE BIOGENESIS SEDIMENT DECONTAMINATION PROCESS, KEASBEY, NEW JERSEY
 (Page 16 of 31)**

Location Identification	Sample Identification/ (QC Sample)	Sample Date	Analysis	Analyte	Sample Result	Sample Units	QC Type	QC Result	QC Units	QC Limit(s)	Bias	Comment
TS	TS-270306-1320	03/27/06	SW-846 8270 SIM	Acenaphthene	130 D	µg/kg	MS	0	%	40-115	None	MS/MSD not recovered due to sample dilution
				Acenaphthylene	260 D		MSD	0		40-115		
				Anthracene	490 D					40-115		
				Benzo(a)anthracene	1100 D					40-115		
				Benzo(a)pyrene	1100 D					40-115		
				Benzo(b)fluoranthene	1200 D					36-115		
				Benzo(g,h,i)perylene	940 D					34-119		
				Benzo(k)fluoranthene	540 D					36-115		
				Chrysene	1900 D					40-115		
				Dibenz(a,h)anthracene	260 D					40-115		
				Fluoranthene	2600 D					40-115		
				Fluorene	150 D					40-115		
				Indeno(1,2,3-c,d)pyrene	750 D					40-115		
				Naphthalene	170 D					40-115		
				Phenanthrene	980 D					40-115		
				Pyrene	1700 D					40-115		
				PSS	PSS-300306-1300	03/30/06	SW-846 8270 SIM	Acenaphthene	220 D	µg/kg		
Acenaphthylene	310 D		MSD					0		40-115		
Anthracene	620 D									40-115		
Benzo(a)anthracene	1200 D									40-115		
Benzo(a)pyrene	1200 D									40-115		
Benzo(b)fluoranthene	1300 D									36-115		
Benzo(g,h,i)perylene	940 D									34-119		
Benzo(k)fluoranthene	480 D									36-115		
Chrysene	1300 D									40-115		
Dibenz(a,h)anthracene	270 D									40-115		
Fluoranthene	2200 D									40-115		
Fluorene	200 D									40-115		
Indeno(1,2,3-c,d)pyrene	740 D									40-115		
Naphthalene	310 D									40-115		
Phenanthrene	1000 D									40-115		
Pyrene	2000 D									40-115		
PSS	PSS-300306-1300	03/30/06	SW-846 6010B					Chromium, total	163	mg/kg	MS MSD	202 197
PSS	PSS-300306-1300	03/30/06	SW-846 7471A	Mercury	6.5	mg/kg	MS MSD	6.97 7.03	%	75-125	None	Sample concentration greater than four times the spike amount
PSS	PSS-300306-1300	03/30/06	SW-846 6010B	Zinc	386	mg/kg	MS MSD	468 445	%	75-125	None	Sample concentration greater than four times the spike amount

TABLE 2

**SUMMARY OF NON-CONFORMING QUALITY CONTROL DATA NOT AFFECTING DATA QUALITY
 DEMONSTRATION TESTING AND FULL-SCALE OPERATION OF THE BIOGENESIS SEDIMENT DECONTAMINATION PROCESS, KEASBEY, NEW JERSEY
 (Page 17 of 31)**

Location Identification	Sample Identification/ (QC Sample)	Sample Date	Analysis	Analyte	Sample Result	Sample Units	QC Type	QC Result	QC Units	QC Limit(s)	Bias	Comment
PSS	PSS-300306-1300-DUP	03/30/06	SW-846 8270 SIM	Acenaphthene	320 D	µg/kg	MS	0	%	40-115	None	MS/MSD not recovered due to sample dilution
				Acenaphthylene	550 D		MSD	0		40-115		
				Anthracene	870 D					40-115		
				Benzo(a)anthracene	1500 D					40-115		
				Benzo(a)pyrene	1700 D					40-115		
				Benzo(b)fluoranthene	1700 D					36-115		
				Benzo(g,h,i)perylene	1300 D					34-119		
				Benzo(k)fluoranthene	700 D					36-115		
				Chrysene	2000 D					40-115		
				Dibenz(a,h)anthracene	340 D					40-115		
				Fluoranthene	3000 D					40-115		
				Fluorene	280 D					40-115		
				Indeno(1,2,3-c,d)pyrene	1000 D					40-115		
				Naphthalene	400 D					40-115		
				Phenanthrene	1200 D					40-115		
				Pyrene	2300 D					40-115		
				PSS	PSS-300306-1300-DUP-SE	03/30/06	SW-846 8270 SIM	Acenaphthene	28 TD	µg/kg		
Acenaphthylene	41 TD		MSD					0		40-115		
Anthracene	98 D									40-115		
Benzo(a)anthracene	140 D									40-115		
Benzo(a)pyrene	130 D									40-115		
Benzo(b)fluoranthene	160 D									36-115		
Benzo(g,h,i)perylene	98 D									34-119		
Benzo(k)fluoranthene	58 D									36-115		
Chrysene	130 D									40-115		
Dibenz(a,h)anthracene	25 TD									40-115		
Fluoranthene	220 D									40-115		
Fluorene	32 TD									40-115		
Indeno(1,2,3-c,d)pyrene	89 D									40-115		
Naphthalene	90 D									40-115		
Phenanthrene	130 D									40-115		
Pyrene	280 D									40-115		
PSS	PSS-030406-1500	04/03/06	SW-846 6010B					Chromium, total	159	mg/kg	MS MSD	192 196
PSS	PSS-030406-1500	04/03/06	SW-846 6010B	Zinc	374	mg/kg	MS MSD	441 441	%	75-125	None	Sample concentration greater than four times the spike amount
PSS	PSS-040406-1200	04/04/06	SW-846 7471A	Mercury	7.1	mg/kg	MS MSD	7.02 7.14	%	75-125	None	Sample concentration greater than four times the spike amount

TABLE 2

**SUMMARY OF NON-CONFORMING QUALITY CONTROL DATA NOT AFFECTING DATA QUALITY
 DEMONSTRATION TESTING AND FULL-SCALE OPERATION OF THE BIOGENESIS SEDIMENT DECONTAMINATION PROCESS, KEASBEY, NEW JERSEY
 (Page 18 of 31)**

Location Identification	Sample Identification/ (QC Sample)	Sample Date	Analysis	Analyte	Sample Result	Sample Units	QC Type	QC Result	QC Units	QC Limit(s)	Bias	Comment
TS1	TS1-040406-1225	04/04/06	SW-846 8270 SIM	Acenaphthene	970 D	µg/kg	MS	0	%	40-115	None	MS/MSD not recovered due to sample dilution
				Acenaphthylene	1300 D		MSD	0		40-115		
				Anthracene	2700 D					40-115		
				Benzo(a)anthracene	5200 D					40-115		
				Benzo(a)pyrene	4500 D					40-115		
				Benzo(b)fluoranthene	4200 D					36-115		
				Benzo(g,h,i)perylene	2600 D					34-119		
				Benzo(k)fluoranthene	1700 D					36-115		
				Chrysene	5600 D					40-115		
				Dibenz(a,h)anthracene	800 D					40-115		
				Fluoranthene	7000 D					40-115		
				Fluorene	980 D					40-115		
				Indeno(1,2,3-c,d)pyrene	2400 D					40-115		
				Naphthalene	920 D					40-115		
				Phenanthrene	6800 D					40-115		
				Pyrene	7200 D					40-115		
PSS	PSS-050406-1200	04/05/06	SW-846 6010B	Chromium, total	183	mg/kg	MS MSD	207 224	%	75-125	None	Sample concentration greater than four times the spike amount
PSS	PSS-050406-1200	04/05/06	SW-846 6010B	Zinc	419	mg/kg	MS MSD	493 518	%	75-125	None	Sample concentration greater than four times the spike amount
SS2	SS2-050406-1210	04/05/06	SW-846 8270 SIM	Acenaphthene	820 D	µg/kg	MS	0	%	40-115	None	MS/MSD not recovered due to sample dilution
				Acenaphthylene	1500 D		MSD	0		40-115		
				Anthracene	3000 D					40-115		
				Benzo(a)anthracene	7000 D					40-115		
				Benzo(a)pyrene	5200 D					40-115		
				Benzo(b)fluoranthene	5600 D					36-115		
				Benzo(g,h,i)perylene	2800 D					34-119		
				Benzo(k)fluoranthene	2000 D					36-115		
				Chrysene	8300 D					40-115		
				Dibenz(a,h)anthracene	830 D					40-115		
				Fluoranthene	15000 D					40-115		
				Fluorene	830 D					40-115		
				Indeno(1,2,3-c,d)pyrene	2700 D					40-115		
				Naphthalene	980 D					40-115		
				Phenanthrene	6300 D					40-115		
				Pyrene	11000 D					40-115		
PSS	PSS-060406-1200	04/06/06	SW-846 6010B	Chromium, total	190	mg/kg	MS MSD	220 245	%	75-125	None	Sample concentration greater than four times the spike amount
PSS	PSS-060406-1200	04/06/06	SW-846 6010B	Zinc	463	mg/kg	MS MSD	511 569	%	75-125	None	Sample concentration greater than four times the spike amount
TS	TS-060406-1240	04/06/06	SW-846 8082	2,2',4,4',5,5'-Pentachlorobiphenyl	<1 3 D	µg/kg	MS MSD	771 754	%	45-150	High	MS/MSD recoveries outside acceptance criteria; analyte not detected in parent sample

TABLE 2

**SUMMARY OF NON-CONFORMING QUALITY CONTROL DATA NOT AFFECTING DATA QUALITY
DEMONSTRATION TESTING AND FULL-SCALE OPERATION OF THE BIOGENESIS SEDIMENT DECONTAMINATION PROCESS, KEASBEY, NEW JERSEY
(Page 19 of 31)**

Location Identification	Sample Identification/ (QC Sample)	Sample Date	Analysis	Analyte	Sample Result	Sample Units	QC Type	QC Result	QC Units	QC Limit(s)	Bias	Comment
TS	TS-060406-1240	04/06/06	SW-846 8081A	Aldrin Dieldrin Endrin Gamma BHC (Lindane) Heptachlor p,p'-DDT	<130 D <130 D <130 D <130 D <130 D 610 D	µg/kg	MS MSD	0 0	%	33-122 33-133 33-138 33-130 32-128 23-144	None	MS/MSD not recovered due to sample dilution
PSS	PSS-100406-1510	04/10/06	SW-846 6010B	Zinc	417	mg/kg	MS MSD	536 511	%	75-125	None	Sample concentration greater than four times the spike amount
TS	TS-100406-1615	04/10/06	SW-846 8082	2,2',3,3',4,4',5,5',6-Nonachlorobiphenyl 2,2',3,3',4,4',5-Heptachlorobiphenyl 2,2',3,4,4',5,5'-Heptachlorobiphenyl 2,2',3,4',5,5',6-Heptachlorobiphenyl 2,2',3,4,5'-Pentachlorobiphenyl 2,2',4,4',5,5'-Hexachlorobiphenyl 2,2',4,5,5'-Pentachlorobiphenyl 2,2',5,5'-Tetrachlorobiphenyl 2,2',5-Trichlorobiphenyl 2,3',4,4'-Tetrachlorobiphenyl	2 4 D 5 3 D 6 D 6 7 D 6 D 13 D <2 0 D 21 D 26 D 26 D	µg/kg	MS MSD	0 0	%	45-150	None	MS/MSD not recovered due to sample dilution
TS	TS-100406-1615	04/10/06	SW-846 8081A	Aldrin Dieldrin Endrin Gamma BHC (Lindane) Heptachlor p,p'-DDT	<130 D <130 D <130 D <130 D <130 D 640 D	µg/kg	MS MSD	0 0	%	33-122 33-133 33-138 33-130 32-128 23-144	None	MS/MSD not recovered due to sample dilution
TS	TS-100406-1615	04/10/06	SW-846 8270 SIM	Benzo(a)anthracene	1200 D	µg/kg	MS MSD	28 31	%	40-115	None	Spike concentration outside the calibration range of the instrument
TS	TS-100406-1615	04/10/06	SW-846 8270 SIM	Benzo(a)pyrene	1200 D	µg/kg	LCS	126	%	50-117	None	Spike concentration outside the linear range of the instrument
TS	TS-100406-1615	04/10/06	SW-846 8270 SIM	Benzo(a)pyrene	1200 D	µg/kg	MS MSD	26 27	%	40-115	None	Spike concentration outside the calibration range of the instrument
TS	TS-100406-1615	04/10/06	SW-846 8270 SIM	Benzo(b)fluoranthene	1300 D	µg/kg	MS MSD	9 4 0 1	%	36-115	None	Spike concentration outside the calibration range of the instrument
TS	TS-100406-1615	04/10/06	SW-846 8270 SIM	Benzo(k)fluoranthene	440 D	µg/kg	LCS	130	%	52-120	None	Spike concentration outside the linear range of the instrument
TS	TS-100406-1615	04/10/06	SW-846 8270 SIM	Chrysene	1500 D	µg/kg	MS MSD	23 22	%	40-115	None	Spike concentration outside the calibration range of the instrument
TS	TS-100406-1615	04/10/06	SW-846 8270 SIM	Dibenz(a,h)anthracene	200 D	µg/kg	LCS	182	%	45-117	None	Spike concentration outside the linear range of the instrument

TABLE 2
SUMMARY OF NON-CONFORMING QUALITY CONTROL DATA NOT AFFECTING DATA QUALITY
DEMONSTRATION TESTING AND FULL-SCALE OPERATION OF THE BIOGENESIS SEDIMENT DECONTAMINATION PROCESS , KEASBEY, NEW JERSEY
(Page 20 of 31)

Location Identification	Sample Identification/ (QC Sample)	Sample Date	Analysis	Analyte	Sample Result	Sample Units	QC Type	QC Result	QC Units	QC Limit(s)	Bias	Comment
TS	TS-100406-1615	04/10/06	SW-846 8270 SIM	Fluoranthene	1800 D	µg/kg	MS	0	%	40-115	None	Spike concentrations outside the linear range of the instrument
TS	TS-100406-1615	04/10/06	SW-846 8270 SIM	Pyrene	1800 D	µg/kg	MSD	0	%	40-115	None	
TS	TS-100406-1615	04/10/06	SW-846 8270 SIM	Indeno(1,2,3-c,d)pyrene	630 D	µg/kg	LCS	164	%	50-122	None	Spike concentration outside the linear range of the instrument
TS	TS-100406-1615	04/10/06	SW-846 8270 SIM	Phenanthrene	990 D	µg/kg	MS MSD	34 35	%	40-115	None	Spike concentration outside the calibration range of the instrument
PSS	PSS-110406-1800	04/11/06	SW-846 6010B	Chromium, total	162	mg/kg	MS MSD	208 200	%	75-125	None	Sample concentration greater than four times the spike amount
PSS	PSS-110406-1800	04/11/06	SW-846 6010B	Zinc	379	mg/kg	MS MSD	496 465	%	75-125	None	Sample concentration greater than four times the spike amount
SS2	SS2-110406-1810	04/11/06	SW-846 8270 SIM	Acenaphthene	620 D	µg/kg	MSD	120	%	40-115	None	Spike concentration outside the calibration range of the instrument
SS2	SS2-110406-1810	04/11/06	SW-846 8270 SIM	Acenaphthylene	960 D	µg/kg	MS MSD	150 163	%	40-115	None	Spike concentration outside the calibration range of the instrument
SS2	SS2-110406-1810	04/11/06	SW-846 8270 SIM	Anthracene	1700 D	µg/kg	MS MSD	224 238	%	40-115	None	Spike concentration outside the calibration range of the instrument
SS2	SS2-110406-1810	04/11/06	SW-846 8270 SIM	Benzo(a)anthracene	3500 D	µg/kg	MS MSD	306 294	%	40-115	None	Spike concentration outside the calibration range of the instrument
SS2	SS2-110406-1810	04/11/06	SW-846 8270 SIM	Benzo(a)pyrene	2800 D	µg/kg	MS MSD	265 244	%	40-115	None	Spike concentration outside the calibration range of the instrument
SS2	SS2-110406-1810	04/11/06	SW-846 8270 SIM	Benzo(b)fluoranthene	3300 D	µg/kg	MS MSD	254 217	%	36-115	None	Spike concentration outside the calibration range of the instrument
SS2	SS2-110406-1810	04/11/06	SW-846 8270 SIM	Benzo(g,h,i)perylene	1300 D	µg/kg	MS MSD	138 132	%	34-119	None	Spike concentration outside the calibration range of the instrument
SS2	SS2-110406-1810	04/11/06	SW-846 8270 SIM	Benzo(k)fluoranthene	1500 D	µg/kg	MS MSD	121 132	%	40-115	None	Spike concentration outside the calibration range of the instrument
SS2	SS2-110406-1810	04/11/06	SW-846 8270 SIM	Chrysene	4200 D	µg/kg	MS MSD	389 385	%	40-115	None	Spike concentration outside the calibration range of the instrument
SS2	SS2-110406-1810	04/11/06	SW-846 8270 SIM	Fluoranthene	6400 D	µg/kg	MS MSD	639 631	%	40-115	None	Spike concentration outside the calibration range of the instrument
SS2	SS2-110406-1810	04/11/06	SW-846 8270 SIM	Indeno(1,2,3-c,d)pyrene	1200 D	µg/kg	MS MSD	138 132	%	40-115	None	Spike concentration outside the calibration range of the instrument
SS2	SS2-110406-1810	04/11/06	SW-846 8270 SIM	Naphthalene	1200 D	µg/kg	MS MSD	117 128	%	40-115	None	Spike concentration outside the calibration range of the instrument

TABLE 2

**SUMMARY OF NON-CONFORMING QUALITY CONTROL DATA NOT AFFECTING DATA QUALITY
DEMONSTRATION TESTING AND FULL-SCALE OPERATION OF THE BIOGENESIS SEDIMENT DECONTAMINATION PROCESS, KEASBEY, NEW JERSEY
(Page 21 of 31)**

Location Identification	Sample Identification/ (QC Sample)	Sample Date	Analysis	Analyte	Sample Result	Sample Units	QC Type	QC Result	QC Units	QC Limit(s)	Bias	Comment
SS2	SS2-110406-1810	04/11/06	SW-846 8270 SIM	Phenanthrene	4700 D	µg/kg	MS MSD	402 430	%	40-115	None	Spike concentration outside the calibration range of the instrument
SS2	SS2-110406-1810	04/11/06	SW-846 8270 SIM	Pyrene	7400 D	µg/kg	MS MSD	635 585	%	40-115	None	Spike concentration outside the calibration range of the instrument
PSS	PSS-120406-1800	04/12/06	SW-846 6010B	Chromium, total	175	mg/kg	MS MSD	206 206	%	75-125	None	Sample concentration greater than four times the spike amount
PSS	PSS-120406-1800	04/12/06	SW-846 7471A	Mercury	7.9	mg/kg	MS MSD	8 8	%	75-125	None	Sample concentration greater than four times the spike amount
PSS	PSS-120406-1800	04/12/06	SW-846 6010B	Zinc	421	mg/kg	MS MSD	483 495	%	75-125	None	Sample concentration greater than four times the spike amount
WS	WS-120406-1840	04/12/06	SW-846 8082	2,2',3,3',4,4',5,5',6-Nonachlorobiphenyl 2,2',3,3',4,4',5-Heptachlorobiphenyl 2,2',3,4,4',5,5'-Heptachlorobiphenyl 2,2',3,4',5,5',6-Heptachlorobiphenyl 2,2',3,4,5,5'-Pentachlorobiphenyl 2,2',4,4',5,5'-Hexachlorobiphenyl 2,2',4,5,5'-Pentachlorobiphenyl 2,2',5,5'-Tetrachlorobiphenyl 2,2',5-Trichlorobiphenyl 2,3',4,4'-Tetrachlorobiphenyl	10 D 20 D 23 D 24 D 21 D 41 D <4.8 D 76 D 90 D 95 D	µg/kg	MS MSD	0 0	%	45-150	None	MS/MSD not recovered due to sample dilution
WS	WS-120406-1840	04/12/06	SW-846 8270C	2,4,6-Trichlorophenol	<5800 D	µg/kg	MS	132	%	50-115	High	MS recovery above acceptance criteria; indicating a high bias. Analyte not detected in parent sample
WS	WS-120406-1840	04/12/06	SW-846 8081A	Aldrin Dieldrin Endrin Gamma BHC (Lindane) Heptachlor p,p'-DDT	<300 D <300 D <300 D <300 D <300 D 180 TD	µg/kg	MS MSD	0 0	%	33-122 33-133 33-138 33-130 32-128 23-144	None	MS/MSD not recovered due to sample dilution
PSS	PSS-130406-1700	04/13/06	SW-846 6010B	Chromium, total	199	mg/kg	MS MSD	241 247	%	75-125	None	Sample concentration greater than four times the spike amount
PSS	PSS-130406-1700	04/13/06	SW-846 6010B	Zinc	461	mg/kg	MS MSD	577 599	%	75-125	None	Sample concentration greater than four times the spike amount
TS1	TS1-130406-1720	04/13/06	SW-846 8270 SIM	Fluoranthene	6800 D	µg/kg	MS MSD	193 214	%	40-115	None	Sample concentration greater than four times the spike amount
TS1	TS1-130406-1720	04/13/06	SW-846 8270 SIM	Pyrene	6500 D	µg/kg	MS MSD	154 188	%	40-115	None	Sample concentration greater than four times the spike amount

TABLE 2

**SUMMARY OF NON-CONFORMING QUALITY CONTROL DATA NOT AFFECTING DATA QUALITY
 DEMONSTRATION TESTING AND FULL-SCALE OPERATION OF THE BIOGENESIS SEDIMENT DECONTAMINATION PROCESS, KEASBEY, NEW JERSEY
 (Page 22 of 31)**

Location Identification	Sample Identification/ (QC Sample)	Sample Date	Analysis	Analyte	Sample Result	Sample Units	QC Type	QC Result	QC Units	QC Limit(s)	Bias	Comment
PSS	PSS-170406-1700	04/17/06	SW-846 6010B	Chromium, total	167	mg/kg	MS MSD	196 197	%	75-125	None	Sample concentration greater than four times the spike amount
PSS	PSS-170406-1700	04/17/06	SW-846 7471A	Mercury	7.2	mg/kg	MS MSD	7.03 6.85	%	75-125	None	Sample concentration greater than four times the spike amount
PSS	PSS-170406-1700	04/17/06	SW-846 6010B	Zinc	392	mg/kg	MS MSD	478 471	%	75-125	None	Sample concentration greater than four times the spike amount
TS	TS-170406-1745	04/17/06	SW-846 8082	2,2',3,3',4,4',5,5',6-Nonachlorobiphenyl 2,2',3,3',4,4',5-Heptachlorobiphenyl 2,2',3,4,4',5,5'-Heptachlorobiphenyl 2,2',3,4',5,5',6-Heptachlorobiphenyl 2,2',3,4,5'-Pentachlorobiphenyl 2,2',4,4',5,5'-Hexachlorobiphenyl 2,2',4,5,5'-Pentachlorobiphenyl 2,2',5,5'-Tetrachlorobiphenyl 2,2',5-Trichlorobiphenyl 2,3',4,4'-Tetrachlorobiphenyl	2.8 D <2.4 D 6.2 D 6.4 D 5.5 D <2.4 D 17 D 20 D 25 D 24 D	µg/kg	MS MSD	0 0	%	45-150	None	MS/MSD not recovered due to sample dilution
TS	TS-170406-1745	04/17/06	SW-846 8081A	Aldrin Dieldrin Endrin Gamma BHC (Lindane) Heptachlor p,p'-DDT	<120 D 18 TD 39 TD <120 D <120 D 1100 D	µg/kg	MS MSD	0 0	%	33-122 33-133 33-138 33-130 32-128 23-144	None	MS/MSD not recovered due to sample dilution
PSS	PSS-180406-1700	04/18/06	SW-846 6010B	Chromium, total	141	mg/kg	MS MSD	171 165	%	75-125	None	Sample concentration greater than four times the spike amount
PSS	PSS-180406-1700	04/18/06	SW-846 7471A	Mercury	6.3	mg/kg	MS MSD	6.33 6.35	%	75-125	None	Sample concentration greater than four times the spike amount
PSS	PSS-180406-1700	04/18/06	SW-846 6010B	Zinc	351	mg/kg	MS MSD	427 418	%	75-125	None	Sample concentration greater than four times the spike amount
TS1	TS1-180406-1720	04/18/06	SW-846 8270 SIM	Fluoranthene	5500 D	µg/kg	MS MSD	137 219	%	40-115	None	Sample concentration greater than four times the spike amount
TS1	TS1-180406-1720	04/18/06	SW-846 8270 SIM	Pyrene	6700 D	µg/kg	MS MSD	180 198	%	40-115	None	Sample concentration greater than four times the spike amount
PSS	PSS-190406-0900	04/19/06	SW-846 6010B	Chromium, total	185	mg/kg	MS MSD	226 224	%	75-125	None	Sample concentration greater than four times the spike amount
PSS	PSS-190406-0900	04/19/06	SW-846 7471A	Mercury	7.2	mg/kg	MS MSD	6.86 7.25	%	75-125	None	Sample concentration greater than four times the spike amount

TABLE 2

**SUMMARY OF NON-CONFORMING QUALITY CONTROL DATA NOT AFFECTING DATA QUALITY
DEMONSTRATION TESTING AND FULL-SCALE OPERATION OF THE BIOGENESIS SEDIMENT DECONTAMINATION PROCESS, KEASBEY, NEW JERSEY
(Page 23 of 31)**

Location Identification	Sample Identification/ (QC Sample)	Sample Date	Analysis	Analyte	Sample Result	Sample Units	QC Type	QC Result	QC Units	QC Limit(s)	Bias	Comment
PSS	PSS-190406-0900	04/19/06	SW-846 6010B	Zinc	475	mg/kg	MS MSD	557 584	%	75-125	None	Sample concentration greater than four times the spike amount
PSS	PSS-200406-1600	04/20/06	SW-846 8290	1,2,3,7,8,9-Hexachlorodibenzofuran	<2 I	pg/g	LCS	125	%	74-123	High	LCS recovery acceptance criteria, indicating a possible high bias; analyte not detected in any associated sample
PSS	PSS-200406-1600	04/20/06	SW-846 8082	2,2',3,3',4,4',5,5',6-Nonachlorobiphenyl 2,2',3,3',4,4',5-Heptachlorobiphenyl 2,2',3,4,4',5,5'-Heptachlorobiphenyl 2,2',3,4',5,5',6-Heptachlorobiphenyl 2,2',3,4,5'-Pentachlorobiphenyl 2,2',4,4',5,5'-Hexachlorobiphenyl 2,2',4,5,5'-Pentachlorobiphenyl 2,2',5,5'-Tetrachlorobiphenyl 2,2',5-Trichlorobiphenyl 2,3',4,4'-Tetrachlorobiphenyl	4 I TD 7 D 9 I D 9 4 D 8 2 D 17 D 25 D 29 D 36 D 36 D	µg/kg	MS MSD	0 0	%	45-150	None	MS/MSD not recovered due to sample dilution
PSS	PSS-200406-1600	04/20/06	SW-846 8081A	Aldrin Dieldrin Endrin Gamma BHC (Lindane) Heptachlor p,p'-DDT	<140 D <140 D 34 TD <140 D <140 D 480 D	µg/kg	MS MSD	0 0	%	33-122 33-133 33-138 33-130 32-128 23-144	None	MS/MSD not recovered due to sample dilution
PSS	PSS-200406-1600	04/20/06	SW-846 6010B	Chromium, total	154	mg/kg	MS MSD	193 192	%	75-125	None	Sample concentration greater than four times the spike amount
PSS	PSS-200406-1600	04/20/06	SW-846 8270C	3/4-Methylphenols (Cresols, m & p)	<5500 D	µg/kg	LCS	127	%	49-119	High	LCS recovery acceptance criteria, indicating a possible high bias; analyte not detected in any associated sample
PSS	PSS-200406-1600	04/20/06	SW-846 6010B	Zinc	372	mg/kg	MS MSD	483 462	%	75-125	None	Sample concentration greater than four times the spike amount
RS	RS-200406-1615 (ICV-042406-1728)	04/20/06	SW-846 8082	2,2',3,4,5'-Pentachlorobiphenyl	<7 I	µg/kg	CVS	16 7	%	<15	None	CVS %D outside acceptance criterion, indicating an unknown bias Analyte not detected in associated samples
TS	TS-200406-1635	04/20/06	SW-846 8082	2,2',3,3',4,4',5,5',6-Nonachlorobiphenyl 2,2',3,3',4,4',5-Heptachlorobiphenyl 2,2',3,4,4',5,5'-Heptachlorobiphenyl 2,2',3,4',5,5',6-Heptachlorobiphenyl 2,2',3,4,5'-Pentachlorobiphenyl 2,2',4,4',5,5'-Hexachlorobiphenyl 2,2',4,5,5'-Pentachlorobiphenyl 2,2',5,5'-Tetrachlorobiphenyl 2,2',5-Trichlorobiphenyl 2,3',4,4'-Tetrachlorobiphenyl	2 3 TD 4 8 D 5 7 D 7 2 D <2 4 D 15 D <2 4 D 21 D 30 D 25 D	µg/kg	MS MSD	0 0	%	45-150	None	MS/MSD not recovered due to sample dilution

TABLE 2

**SUMMARY OF NON-CONFORMING QUALITY CONTROL DATA NOT AFFECTING DATA QUALITY
DEMONSTRATION TESTING AND FULL-SCALE OPERATION OF THE BIOGENESIS SEDIMENT DECONTAMINATION PROCESS , KEASBEY, NEW JERSEY
(Page 24 of 31)**

Location Identification	Sample Identification/ (QC Sample)	Sample Date	Analysis	Analyte	Sample Result	Sample Units	QC Type	QC Result	QC Units	QC Limit(s)	Bias	Comment
TS	TS-200406-1635	04/20/06	SW-846 8081A	Aldrin Dieldrin Endrin Gamma BHC (Lindane) Heptachlor p,p'-DDT	<120 D 16 TD 19 TD <120 D <120 D 700 D	µg/kg	MS MSD	0 0	%	33-122 33-133 33-138 33-130 32-128 23-144	None	MS/MSD not recovered due to sample dilution
TS	TS-200406-1635 (ICV-042406-1728)	04/20/06	SW-846 8082	2,2',3,4,5'-Pentachlorobiphenyl	<2.4	µg/kg	CVS	16.7	%	<15	None	CVS %D outside acceptance criterion, indicating an unknown bias. Analyte not detected in associated samples.
WS	WS-200406-1640 (ICV-042406-1728)	04/20/06	SW-846 8082	2,2',3,4,5'-Pentachlorobiphenyl	<6.1	µg/kg	CVS	16.7	%	<15	None	CVS %D outside acceptance criterion, indicating an unknown bias. Analyte not detected in associated samples.
PSS	PSS-210406-1400	04/21/06	SW-846 6010B	Chromium, total	165	mg/kg	MS MSD	197 203	%	75-125	None	Sample concentration greater than four times the spike amount.
PSS	PSS-210406-1400	04/21/06	SW-846 6010B	Lead	260	mg/kg	MS MSD	466 337	%	75-125	None	Sample concentration greater than four times the spike amount.
PSS	PSS-210406-1400	04/21/06	SW-846 6010B	Zinc	393	mg/kg	MS MSD	468 481	%	75-125	None	Sample concentration greater than four times the spike amount.
PSS SS1 SS2 RS TS1 TS2 TS3 TS WS	PSS-210406-1400 SS1-210406-1405 SS2-210406-1410 RS-210406-1415 TS1-210406-1420 TS2-210406-1425 TS3-210406-1430 TS-21406-1435 WS-210406-1440	04/21/06	SW-846 8270C	All SVOC analytes	N/A	µg/kg	TEMP	14	°C	±4		Cooler temperature outside acceptance criterion at time of laboratory receipt. Analytes of concern not volatile at this temperature.
PSS SS1 SS2 RS TS1 TS2 TS3 TS WS	PSS-210406-1400 SS1-210406-1405 SS2-210406-1410 RS-210406-1415 TS1-210406-1420 TS2-210406-1425 TS3-210406-1430 TS-21406-1435 WS-210406-1440	04/21/06	SW-846 6010B	All target analyte metals	N/A	mg/kg	TEMP	14	°C	±4		Cooler temperature outside acceptance criterion at time of laboratory receipt. Analytes of concern not volatile at this temperature.

TABLE 2

**SUMMARY OF NON-CONFORMING QUALITY CONTROL DATA NOT AFFECTING DATA QUALITY
DEMONSTRATION TESTING AND FULL-SCALE OPERATION OF THE BIOGENESIS SEDIMENT DECONTAMINATION PROCESS, KEASBEY, NEW JERSEY
(Page 25 of 31)**

Location Identification	Sample Identification/ (QC Sample)	Sample Date	Analysis	Analyte	Sample Result	Sample Units	QC Type	QC Result	QC Units	QC Limit(s)	Bias	Comment
PSS SS1 SS2 RS TS1 TS2 TS3 TS WS	PSS-210406-1400 SS1-210406-1405 SS2-210406-1410 RS-210406-1415 TS1-210406-1420 TS2-210406-1425 TS3-210406-1430 TS-21406-1435 WS-210406-1440	04/21/06	SW-846 7471A	Mercury	N/A	mg/kg	TEMP	14	°C	±4		Cooler temperature outside acceptance criterion at time of laboratory receipt Analytes of concern not volatile at this temperature
PSS SS1 SS2 RS TS1 TS2 TS3 TS WS	PSS-210406-1400 SS1-210406-1405 SS2-210406-1410 RS-210406-1415 TS1-210406-1420 TS2-210406-1425 TS3-210406-1430 TS-21406-1435 WS-210406-1440	04/21/06	Lloyd Kahn	Total organic carbon	N/A	mg/kg	TEMP	14	°C	±4		Cooler temperature outside acceptance criterion at time of laboratory receipt Analytes of concern not volatile at this temperature
TS1	TS1-210406-1420	04/21/06	SW-846 8270 SIM	Fluoranthene	7700 D	µg/kg	MS MSD	133 157	%	40-115	None	Sample concentration greater than four times the spike amount
TS1	TS1-210406-1420	04/21/06	SW-846 8270 SIM	Pyrene	6500 D	µg/kg	MS MSD	171 158	%	40-115	None	Sample concentration greater than four times the spike amount
PSS	PSS-240406-1600	04/24/06	SW-846 6010B	Chromium, total	206	mg/kg	MS MSD	217 247	%	75-125	None	Sample concentration greater than four times the spike amount
PSS	PSS-240406-1600	04/24/06	SW-846 6010B	Zinc	497	mg/kg	MS MSD	560 606	%	75-125	None	Sample concentration greater than four times the spike amount
RS	RS-240406-1615 (INF1-250406-1845)	04/24/06	SW-846 8270 SIM	Acenaphthylene	270 D	µg/kg	FD	63 0	%	50	None	Field duplicate RPD outside acceptable criterion
RS	RS-240406-1615 (INF1-250406-1845)	04/24/06	SW-846 8270 SIM	Anthracene	490 D	µg/kg	FD	55 1	%	50	None	Field duplicate RPD outside acceptable criterion
RS	RS-240406-1615 (INF1-250406-1845)	04/24/06	SW-846 8270 SIM	Dibenz(a,h)anthracene	160 TD	µg/kg	FD	56 3	%	50	None	Field duplicate RPD outside acceptable criterion
RS	RS-240406-1615 (INF1-250406-1845)	04/24/06	SW-846 8270 SIM	Fluorene	170 TD	µg/kg	FD	52 9	%	50	None	Field duplicate RPD outside acceptable criterion
RS	RS-240406-1615 (INF1-250406-1845)	04/24/06	SW-846 7471A	Mercury	4 7	mg/kg	FD	50 8	%	50	None	Field duplicate RPD outside acceptable criterion
RS	RS-240406-1615 (INF1-250406-1845)	04/24/06	Lloyd Kahn	Total organic carbon	28900	mg/kg	FD	68 6	%	50	None	Field duplicate RPD outside acceptable criterion

TABLE 2

**SUMMARY OF NON-CONFORMING QUALITY CONTROL DATA NOT AFFECTING DATA QUALITY
DEMONSTRATION TESTING AND FULL-SCALE OPERATION OF THE BIOGENESIS SEDIMENT DECONTAMINATION PROCESS, KEASBEY, NEW JERSEY
(Page 26 of 31)**

Location Identification	Sample Identification/ (QC Sample)	Sample Date	Analysis	Analyte	Sample Result	Sample Units	QC Type	QC Result	QC Units	QC Limit(s)	Bias	Comment
RS	RS-240406-1615 (INF1-260406-1345)	04/24/06	Lloyd Kahn	Total organic carbon	28900	mg/kg	FD	56.4	%	50	None	Field duplicate RPD outside acceptable criterion
TS1	TS1-240406-1620	04/24/06	SW-846 8270 SIM	Benzo(a)pyrene	5600 D	µg/kg	MS MSD	136 174	%	40-115	None	Sample concentration greater than four times the spike amount
TS1	TS1-240406-1620	04/24/06	SW-846 8270 SIM	Fluoranthene	9000 D	µg/kg	MS MSD	206 208	%	40-115	None	Sample concentration greater than four times the spike amount
TS1	TS1-240406-1620	04/24/06	SW-846 8270 SIM	Phenanthrene	6100 D	µg/kg	MS MSD	175 207	%	40-115	None	Sample concentration greater than four times the spike amount
TS1	TS1-240406-1620	04/24/06	SW-846 8270 SIM	Pyrene	8900 D	µg/kg	MS MSD	137 145	%	40-115	None	Sample concentration greater than four times the spike amount
PSS	PSS-250406-1800	04/25/06	SW-846 6010B	Chromium, total	158	mg/kg	MS MSD	202 183	%	75-125	None	Sample concentration greater than four times the spike amount
PSS	PSS-250406-1800	04/25/06	SW-846 7471A	Mercury	6.8	mg/kg	MS MSD	7.22 7.23	%	75-125	None	Sample concentration greater than four times the spike amount
PSS	PSS-250406-1800	04/25/06	SW-846 6010B	Zinc	395	mg/kg	MS MSD	540 435	%	75-125	None	Sample concentration greater than four times the spike amount
WS	WS-250406-1840	04/25/06	SW-846 8082	2,2',3,3',4,4',5,5',6-Nonachlorobiphenyl 2,2',3,3',4,4',5-Heptachlorobiphenyl 2,2',3,4,4',5,5'-Heptachlorobiphenyl 2,2',3,4',5,5',6-Heptachlorobiphenyl 2,2',3,4,5'-Pentachlorobiphenyl 2,2',4,4',5,5'-Hexachlorobiphenyl 2,2',4,5,5'-Pentachlorobiphenyl 2,2',5,5'-Tetrachlorobiphenyl 2,2',5-Trichlorobiphenyl 2,3',4,4'-Tetrachlorobiphenyl	15 D 23 D 28 D 28 D 23 D 52 D <5.8 D 89 D 110 D 110 D	µg/kg	MS MSD	0 0	%	45-150	None	MS/MSD not recovered due to sample dilution
WS	WS-250406-1840	04/25/06	SW-846 8081A	Aldrin Dieldrin Endrin Gamma BHC (Lindane) Heptachlor p,p'-DDT	<140 D <140 D 36 TD <140 D <140 D 140 D	µg/kg	MS MSD	0 0	%	33-122 33-133 33-138 33-130 32-128 23-144	None	MS/MSD not recovered due to sample dilution
PSS	PSS-260406-1300	04/26/06	SW-846 6010B	Chromium, total	151	mg/kg	MS MSD	178 204	%	75-125	None	Sample concentration greater than four times the spike amount
PSS	PSS-260406-1300	04/26/06	SW-846 6010B	Zinc	371	mg/kg	MS MSD	431 452	%	75-125	None	Sample concentration greater than four times the spike amount

TABLE 2

**SUMMARY OF NON-CONFORMING QUALITY CONTROL DATA NOT AFFECTING DATA QUALITY
 DEMONSTRATION TESTING AND FULL-SCALE OPERATION OF THE BIOGENESIS SEDIMENT DECONTAMINATION PROCESS, KEASBEY, NEW JERSEY
 (Page 27 of 31)**

Location Identification	Sample Identification/ (QC Sample)	Sample Date	Analysis	Analyte	Sample Result	Sample Units	QC Type	QC Result	QC Units	QC Limit(s)	Bias	Comment
TS1	TS1-260406-1320	04/26/06	SW-846 8270 SIM	Fluoranthene	5300 D	µg/kg	MS MSD	31 35	%	40-115	None	Sample concentration greater than four times the spike amount
TS1	TS1-260406-1320	04/26/06	SW-846 8270 SIM	Pyrene	5500 D	µg/kg	MS MSD	24 21	%	40-115	None	Sample concentration greater than four times the spike amount
PSS	PSS-270406-1700	04/27/06	SW-846 6010B	Chromium, total	199	mg/kg	MS MSD	203 219	%	75-125	None	Sample concentration greater than four times the spike amount
PSS	PSS-270406-1700	04/27/06	SW-846 7471A	Mercury	7.7	mg/kg	MS MSD	8.45 7.75	%	75-125	None	Sample concentration greater than four times the spike amount
PSS	PSS-270406-1700	04/27/06	SW-846 6010B	Zinc	476	mg/kg	MS MSD	469 490	%	75-125	None	Sample concentration greater than four times the spike amount
WS	WS-270406-1740	04/27/06	SW-846 8082	2,2',3,3',4,4',5,5',6-Nonachlorobiphenyl 2,2',3,3',4,4',5-Heptachlorobiphenyl 2,2',3,4,4',5,5'-Heptachlorobiphenyl 2,2',3,4',5,5',6-Heptachlorobiphenyl 2,2',3,4,5,5'-Pentachlorobiphenyl 2,2',4,4',5,5'-Hexachlorobiphenyl 2,2',4,5,5'-Pentachlorobiphenyl 2,2',5,5'-Tetrachlorobiphenyl 2,2',5-Trichlorobiphenyl 2,3',4,4'-Tetrachlorobiphenyl	16 D 27 D 32 D 34 D 30 D 60 D 94 D 110 D 140 D 130 D	µg/kg	MS MSD	0 0	%	45-150	None	MS/MSD not recovered due to sample dilution
WS	WS-270406-1740	04/27/06	SW-846 8081A	Aldrin Dieldrin Endrin Gamma BHC (Lindane) Heptachlor p,p'-DDT	<170 D <170 D 48 TD <170 D <170 D 250 D	µg/kg	MS MSD	0 0	%	33-122 33-133 33-138 33-130 32-128 23-144	None	MS/MSD not recovered due to sample dilution
WS	WS-270406-1740	04/27/06	SW-846 8270C	Fluoranthene	1300 TD	µg/kg	MS	137	%	53-115	None	Sample concentration greater than four times the spike amount
PSS	PSS-280406-1100	04/28/06	SW-846 6010B	Chromium, total	202	mg/kg	MS MSD	240 225	%	75-125	None	Sample concentration greater than four times the spike amount
PSS	PSS-280406-1100	04/28/06	SW-846 7471A	Mercury	8.7	mg/kg	MS MSD	8.22 8.32	%	75-125	None	Sample concentration greater than four times the spike amount
PSS	PSS-280406-1100	04/28/06	SW-846 6010B	Zinc	473	mg/kg	MS MSD	544 555	%	75-125	None	Sample concentration greater than four times the spike amount
TS1	TS1-280406-1120	04/28/06	SW-846 8270 SIM	Fluoranthene	5600 D	µg/kg	MSD	0	%	40-115	None	Sample concentration greater than four times the spike amount
TS1	TS1-280406-1120	04/28/06	SW-846 8270 SIM	Pyrene	5200 D	µg/kg	MS	19	%	40-115	None	Sample concentration greater than four times the spike amount

TABLE 2

**SUMMARY OF NON-CONFORMING QUALITY CONTROL DATA NOT AFFECTING DATA QUALITY
 DEMONSTRATION TESTING AND FULL-SCALE OPERATION OF THE BIOGENESIS SEDIMENT DECONTAMINATION PROCESS, KEASBEY, NEW JERSEY
 (Page 28 of 31)**

Location Identification	Sample Identification/ (QC Sample)	Sample Date	Analysis	Analyte	Sample Result	Sample Units	QC Type	QC Result	QC Units	QC Limit(s)	Bias	Comment
PSS	PSS-010506-1600	05/01/06	SW-846 6010B	Chromium, total	256	mg/kg	MS MSD	275 274	%	75-125	None	Sample concentration greater than four times the spike amount
PSS	PSS-010506-1600	05/01/06	SW-846 6010B	Lead	521	mg/kg	MS MSD	572 588	%	75-125	None	Sample concentration greater than four times the spike amount
PSS	PSS-010506-1600	05/01/06	SW-846 7471A	Mercury	6	mg/kg	MS MSD	6 08 5 76	%	75-125	None	Sample concentration greater than four times the spike amount
PSS	PSS-010506-1600	05/01/06	SW-846 6010B	Zinc	935	mg/kg	MS MSD	916 948	%	75-125	None	Sample concentration greater than four times the spike amount
TS3	TS3-010506-1630	05/01/06	SW-846 8082	2,2',3,3',4,4',5,5',6-Nonachlorobiphenyl 2,2',3,3',4,4',5-Heptachlorobiphenyl 2,2',3,4,4',5,5'-Heptachlorobiphenyl 2,2',3,4',5,5',6-Heptachlorobiphenyl 2,2',3,4,5'-Pentachlorobiphenyl 2,2',4,4',5,5'-Hexachlorobiphenyl 2,2',4,5,5'-Pentachlorobiphenyl 2,2',5,5'-Tetrachlorobiphenyl 2,2',5-Trichlorobiphenyl 2,3',4,4'-Tetrachlorobiphenyl	4 2 D 12 D 19 D 13 D 10 D 24 D 25 D 49 D 52 D 43 D	µg/kg	MS MSD	0 0	%	45-150	None	MS/MSD not recovered due to sample dilution
TS3	TS3-010506-1630	05/01/06	SW-846 8270C	2-Methylphenol (o-Cresol)	<5100 D	µg/kg	MS	116	%	45-115	High	MS recovery above acceptance criteria; indicating a high bias Analyte not detected in parent sample
TS3	TS3-010506-1630	05/01/06	SW-846 8081A	Aldrin Dieldrin Endrin Gamma BHC (Lindane) Heptachlor p,p'-DDT	<66 D 20 TD 36 TD <66 D <66 D 240 D	µg/kg	MS MSD	0 0	%	33-122 33-133 33-138 33-130 32-128 23-144	None	MS/MSD not recovered due to sample dilution
TS3	TS3-010506-1630	05/01/06	SW-846 8270C	3/4-Methylphenols (Cresols, m & p)	<5100 D	µg/kg	MS	121	%	49-119	High	MS recovery above acceptance criteria; indicating a high bias Analyte not detected in parent sample
PSS	PSS-020506-1600	05/02/06	SW-846 6010B	Chromium, total	251	mg/kg	MS MSD	275 265	%	75-125	None	Sample concentration greater than four times the spike amount
PSS	PSS-020506-1600	05/02/06	SW-846 6010B	Lead	505	mg/kg	MS MSD	563 549	%	75-125	None	Sample concentration greater than four times the spike amount
PSS	PSS-020506-1600	05/02/06	SW-846 7471A	Mercury	4 5	mg/kg	MS MSD	4 64 4 68	%	75-125	None	Sample concentration greater than four times the spike amount
PSS	PSS-020506-1600	05/02/06	SW-846 6010B	Zinc	886	mg/kg	MS MSD	922 896	%	75-125	None	Sample concentration greater than four times the spike amount

TABLE 2

**SUMMARY OF NON-CONFORMING QUALITY CONTROL DATA NOT AFFECTING DATA QUALITY
DEMONSTRATION TESTING AND FULL-SCALE OPERATION OF THE BIOGENESIS SEDIMENT DECONTAMINATION PROCESS, KEASBEY, NEW JERSEY
(Page 29 of 31)**

Location Identification	Sample Identification/ (QC Sample)	Sample Date	Analysis	Analyte	Sample Result	Sample Units	QC Type	QC Result	QC Units	QC Limit(s)	Bias	Comment
TS1	TS1-020506-1620	05/02/06	SW-846 9071	Total petroleum hydrocarbons	6720	mg/kg	MS MSD	0 0	%	64-132	None	Sample concentration greater than four times the spike amount
PSS	PSS-030506-1600	05/03/06	SW-846 6010B	Chromium, total	195	mg/kg	MS MSD	208 209	%	75-125	None	Sample concentration greater than four times the spike amount
PSS	PSS-030506-1600	05/03/06	SW-846 6010B	Lead	412	mg/kg	MS MSD	450 443	%	75-125	None	Sample concentration greater than four times the spike amount
PSS	PSS-030506-1600	05/03/06	SW-846 7471A	Mercury	4.3	mg/kg	MS MSD	4.22 4.19	%	75-125	None	Sample concentration greater than four times the spike amount
PSS	PSS-030506-1600	05/03/06	SW-846 6010B	Zinc	677	mg/kg	MS MSD	713 721	%	75-125	None	Sample concentration greater than four times the spike amount
WS	WS-030506-1640	05/03/06	SW-846 8082	2,2',3,3',4,4',5,5',6-Nonachlorobiphenyl 2,2',3,3',4,4',5,5'-Heptachlorobiphenyl 2,2',3,4,4',5,5'-Heptachlorobiphenyl 2,2',3,4',5,5',6-Heptachlorobiphenyl 2,2',3,4,5,5'-Pentachlorobiphenyl 2,2',4,4',5,5'-Hexachlorobiphenyl 2,2',4,5,5'-Pentachlorobiphenyl 2,2',5,5'-Tetrachlorobiphenyl 2,2',5-Trichlorobiphenyl 2,3',4,4'-Tetrachlorobiphenyl	8.7 D 21 D 27 D 26 D 16 D 43 D <6.5 D 79 D 88 D 72 D	µg/kg	MS MSD	0 0	%	45-150	None	MS/MSD not recovered due to sample dilution
WS	WS-030506-1640	05/03/06	SW-846 8081A	Aldrin Dieldrin Endrin Gamma BHC (Lindane) Heptachlor p,p'-DDT	<160 D 40 TD 85 TD <160 D <160 D 160 D	µg/kg	MS MSD	0 0	%	33-122 33-133 33-138 33-130 32-128 23-144	None	MS/MSD not recovered due to sample dilution
PSS	PSS-040506-1600	05/04/06	SW-846 6010B	Chromium, total	178	mg/kg	MS MSD	198 199	%	75-125	None	Sample concentration greater than four times the spike amount
PSS	PSS-040506-1600	05/04/06	SW-846 6010B	Lead	354	mg/kg	MS MSD	405 405	%	75-125	None	Sample concentration greater than four times the spike amount
PSS	PSS-040506-1600	05/04/06	SW-846 6010B	Zinc	620	mg/kg	MS MSD	668 661	%	75-125	None	Sample concentration greater than four times the spike amount

TABLE 2

**SUMMARY OF NON-CONFORMING QUALITY CONTROL DATA NOT AFFECTING DATA QUALITY
 DEMONSTRATION TESTING AND FULL-SCALE OPERATION OF THE BIOGENESIS SEDIMENT DECONTAMINATION PROCESS, KEASBEY, NEW JERSEY
 (Page 30 of 31)**

Location Identification	Sample Identification/ (QC Sample)	Sample Date	Analysis	Analyte	Sample Result	Sample Units	QC Type	QC Result	QC Units	QC Limit(s)	Bias	Comment
TS1	TS1-040506-1620	05/04/06	SW-846 8270 SIM	Acenaphthene	520 D	µg/kg	MS	0	%	40-115	None	MS/MSD not recovered due to sample dilution
				Acenaphthylene	900 D		MSD	0		40-115		
				Anthracene	1700 D					40-115		
				Benzo(a)anthracene	3200 D					40-115		
				Benzo(a)pyrene	2800 D					40-115		
				Benzo(b)fluoranthene	2600 D					36-115		
				Benzo(g,h,i)perylene	1500 D					34-119		
				Benzo(k)fluoranthene	1100 D					36-115		
				Chrysene	3400 D					40-115		
				Dibenz(a,h)anthracene	460 D					40-115		
				Fluoranthene	4800 D					40-115		
				Fluorene	640 D					40-115		
				Indeno(1,2,3-c,d)pyrene	1500 D					40-115		
				Naphthalene	690 D					40-115		
				Phenanthrene	4500 D					40-115		
				Pyrene	4500 D					40-115		
TS1	TS1-040506-1620	05/04/06	SW-846 9071	Total petroleum hydrocarbons	8840	mg/kg	MS MSD	0 0	%	64-132	None	Sample concentration greater than four times the spike amount
TS1	TS1-040506-1620B	05/04/06	SW-846 8270 SIM	Acenaphthene	2750 D	µg/kg	MS	0	%	40-115	None	Sample concentration greater than four times the spike amount
TS1	TS1-040506-1620B	05/04/06	SW-846 8270 SIM	Acenaphthylene	4570 D	µg/kg	MS	197	%	40-115	None	Sample concentration greater than four times the spike amount
TS1	TS1-040506-1620B	05/04/06	SW-846 8270 SIM	Anthracene	8420 D	µg/kg	MS	1051	%	40-115	None	Sample concentration greater than four times the spike amount
TS1	TS1-040506-1620B	05/04/06	SW-846 8270 SIM	Benzo(a)anthracene	16100 D	µg/kg	MS	576	%	40-115	None	Sample concentration greater than four times the spike amount
TS1	TS1-040506-1620B	05/04/06	SW-846 8270 SIM	Benzo(a)pyrene	17200 D	µg/kg	MS	627	%	40-115	None	Sample concentration greater than four times the spike amount
TS1	TS1-040506-1620B	05/04/06	SW-846 8270 SIM	Benzo(b)fluoranthene	12320 D	µg/kg	MS	286	%	36-115	None	Sample concentration greater than four times the spike amount
TS1	TS1-040506-1620B	05/04/06	SW-846 8270 SIM	Benzo(g,h,i)perylene	11500 D	µg/kg	MS	384	%	34-119	None	Sample concentration greater than four times the spike amount
TS1	TS1-040506-1620B	05/04/06	SW-846 8270 SIM	Benzo(k)fluoranthene	13800 D	µg/kg	MS	376	%	36-115	None	Sample concentration greater than four times the spike amount
TS1	TS1-040506-1620B	05/04/06	SW-846 8270 SIM	Chrysene	18300 D	µg/kg	MS	796	%	40-115	None	Sample concentration greater than four times the spike amount
TS1	TS1-040506-1620B	05/04/06	SW-846 8270 SIM	Dibenz(a,h)anthracene	3750 D	µg/kg	MS	181	%	40-115	None	Sample concentration greater than four times the spike amount

TABLE 2

**SUMMARY OF NON-CONFORMING QUALITY CONTROL DATA NOT AFFECTING DATA QUALITY
 DEMONSTRATION TESTING AND FULL-SCALE OPERATION OF THE BIOGENESIS SEDIMENT DECONTAMINATION PROCESS , KEASBEY, NEW JERSEY
 (Page 31 of 31)**

Location Identification	Sample Identification/ (QC Sample)	Sample Date	Analysis	Analyte	Sample Result	Sample Units	QC Type	QC Result	QC Units	QC Limit(s)	Bias	Comment
TS1	TS1-040506-1620B	05/04/06	SW-846 8270 SIM	Fluoranthene	41600 D	µg/kg	MS	695	%	40-115	None	Sample concentration greater than four times the spike amount
TS1	TS1-040506-1620B	05/04/06	SW-846 8270 SIM	Indeno(1,2,3-c,d)pyrene	9540 D	µg/kg	MS	360	%	40-115	None	Sample concentration greater than four times the spike amount
TS1	TS1-040506-1620B	05/04/06	SW-846 8270 SIM	Naphthalene	3370 D	µg/kg	MS	0	%	40-115	None	Sample concentration greater than four times the spike amount
TS1	TS1-040506-1620B	05/04/06	SW-846 8270 SIM	Phenanthrene	19100 D	µg/kg	MS	0	%	40-115	None	Sample concentration greater than four times the spike amount
TS1	TS1-040506-1620B	05/04/06	SW-846 8270 SIM	Pyrene	42900 D	µg/kg	MS	380	%	40-115	None	Sample concentration greater than four times the spike amount

µg/kg	micrograms per kilogram
mg/kg	milligrams per kilogram
pg/g	picograms per gram
CVS	Calibration verification standard
Dup	Duplicate
FD	Field duplicate
ICAL	Initial calibration
LCS	Laboratory control sample
LB	Laboratory blank
MS	Matrix spike sample
MSD	Matrix spike duplicate sample
N/A	Not applicable
%RSD	Percent relative standard deviation
RPD	Relative percent difference
RRF	Relative response factor
TEMP	Temperature
D	Sample dilution required for analysis; reported values reflect the dilution
T	Analyte was positively identified but the reported concentration is estimated; reported concentration is less than the reporting limit, but greater than the method detection limit

APPENDIX D
MIDDLESEX COUNTY UTILITIES AUTHORITY
MONTHLY MONITORING REPORTS

***DEMONSTRATION TESTING AND
FULL-SCALE OPERATION OF THE
BIOGENESISSM SEDIMENT DECONTAMINATION
PROCESS***

MIDDLESEX COUNTY UTILITIES AUTHORITY

Self-Monitoring Report
Transmittal Sheet

MCUA TDA No.: 009-05

Reporting Period: 1/01/06 through 1/31/06

Permitted facility: Name: Biogenesis Sediment Washing LLC
Address: 75 Crows Mill Road
Keasbey, New Jersey 08832
Telephone No.: 732-738-3184

OPERATING EXCEPTIONS

	Yes	No
Dye Testing	_____	<input checked="" type="checkbox"/>
Temporary Bypassing	_____	<input checked="" type="checkbox"/>
Monitoring Malfunctions	_____	<input checked="" type="checkbox"/>
Units Out of Operation	_____	<input checked="" type="checkbox"/>
Other	<input checked="" type="checkbox"/>	_____

(Put any "yes" on a separate sheet of paper.)

AUTHENTICATION

I certify under penalty of law that I have personally examined and am familiar with the information submitted in this document and all attachments and that, based on my inquiry of those individuals immediately responsible for obtaining the information, I believe the submitted information is true, accurate and complete. I am aware that there are significant penalties for submitting false information including the possibility of fine and imprisonment.

John Sontag, Jr.
Signature of Authorized Representative

Feb. 25, 2006
Date

John Sontag, Jr. Sr. Program Mgr.
Type or Print Name and Title of Authorized Representative

Operating Exceptions – January 2006

1. On January 3, 2006, the pH reading in the final effluent samples read 12.2. The pH control system was adjusted and process changes were made.

Samples taken the next day show pH at 8.4, with no pH readings above 9.1 the rest of the month.

2. One sample of wastewater on 1/31 showed nickel content of 0.552, which was above the daily maximum limit of 0.36 mg/l. Samples taken on days previous to the 31st and after the 31st show concentrations below the daily limit. Nickel concentrations are within the monthly 30-day limit.

MIDDLESEX COUNTY UTILITIES AUTHORITY (MCUA)
SELF-MONITORING REPORT (SMR)

PERMITTEE NAME / ADDRESS

NAME: BIOGENESIS SEDIMENT WASHINGTON

ADDRESS: 75 CROWS MILL ROAD

KEASBEY, NEW JERSEY 08832

MCUA TDA NUMBER: 008-05

DISCHARGE POINT: DSN 001

MONITORING PERIOD: FROM 1/01/06 TO 1/31/06

PARAMETER	QUANTITY OR LOADING			QUALITY OR CONCENTRATION			# OF VIOLATIONS	FREQUENCY OF ANALYSIS	SAMPLE TYPE	
	AVERAGE	MAXIMUM	UNITS	MINIMUM	AVERAGE	MAXIMUM				UNITS
Flow	Sample Measurement	0.035	0.107		*****	*****	0	CONT.	N/A	
	Permit Requirement	0.360 30-DAY AVG.	DAILY MAX	MGD	*****	*****		CONTINUOUS	N/A	
Flow (Total)	Sample Measurement	1.07	1.07		*****	*****	0	CONT.	N/A	
	Permit Requirement	REPORT MONTHLY	38,880 TOTAL TO DATE	MG	*****	*****		CONTINUOUS	N/A	
Flow (gpm)	Sample Measurement	24	191		*****	*****	0	CONT.	N/A	
	Permit Requirement	REPORT 30-DAY AVG.	250 DAILY MAX	GPM	*****	*****		CONTINUOUS	N/A	
pH (Grab)	Sample Measurement	*****	*****	7.4	*****	12.1	1	Daily	Grab	
	Permit Requirement	*****	*****	5.0 MINIMUM	*****	10.0 MAXIMUM		DAILY	GRAB	
BOD, 5 DAY	Sample Measurement	2.01	1.98		*****	136	0	Daily	Grab	
	Permit Requirement	REPORT 30-DAY AVG.	REPORT DAILY MAX	KG DAY	*****	REPORT DAILY MAX		WEEKLY	GRAB	
COD	Sample Measurement	17.03	132		*****	666	0	to Daily	COMP.	
	Permit Requirement	REPORT 30-DAY AVG.	REPORT DAILY MAX	KG DAY	*****	REPORT DAILY MAX		WEEKLY	COMP.	
Total Suspended Solids (TSS)	Sample Measurement	0.96	8.67		*****	80	0	Daily	COMP.	
	Permit Requirement	REPORT 30-DAY AVG.	REPORT DAILY MAX	KG DAY	*****	REPORT DAILY MAX		DAILY	COMP.	
<p>I CERTIFY UNDER PENALTY OF LAW THAT I HAVE PERSONALLY EXAMINED AND AM FAMILIAR WITH THE INFORMATION SUBMITTED IN THIS DOCUMENT AND ALL ATTACHMENTS AND THAT, BASED ON MY INQUIRY OF THESE INDIVIDUALS IMMEDIATELY RESPONSIBLE FOR OBTAINING THE INFORMATION, I BELIEVE THE SUBMITTED INFORMATION IS TRUE, ACCURATE AND COMPLETE. I AM AWARE THAT THERE ARE SIGNIFICANT PENALTIES FOR SUBMITTING FALSE INFORMATION, INCLUDING THE POSSIBILITY OF FINE AND IMPRISONMENT.</p>										
NAME / TITLE OF AUTHORIZED REPRESENTATIVE John Santegny, Jr. Sr. Program Mgr.		SIGNATURE OF AUTHORIZED REPRESENTATIVE 			AREA CODE 732		TELEPHONE NUMBER 738-3184		DATE 2006 02 25	

ATTACH COMMENTS AND EXPLANATIONS OF ANY VIOLATIONS

MIDDLESEX COUNTY UTILITIES AUTHORITY (MCUA)
SELF-MONITORING REPORT (SMR)

PERMITTEE NAME / ADDRESS

NAME: BIOGENESIS SEDIMENT WASHING LLC

ADDRESS: 75 CROWS MILL ROAD

KEASBEY, NEW JERSEY 08832

MCUA TDA NUMBER: 009-05

DISCHARGE POINT: DSN.001

MONITORING PERIOD: FROM 10/1/06 TO 1/31/06

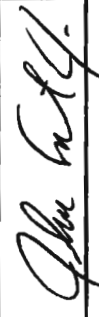
PARAMETER	QUANTITY OR LOADING		QUALITY OR CONCENTRATION			# OF VIOLATIONS	FREQUENCY OF ANALYSIS	SAMPLE TYPE		
	AVERAGE	MAXIMUM	UNITS	MINIMUM	AVERAGE				MAXIMUM	UNITS
Total Petroleum Hydrocarbons	Sample Measurement	< 0.66	< 6.6	*****	< 5	< 50	0	Daily	Grab	
	Permit Requirement	REPORT 30-DAY AVG.	REPORT DAILY MAX	*****	100 30-DAY AVG.	150 DAILY MAX		WEEKLY	GRAB	
Cyanide (Total)	Sample Measurement	< 0.001	< 0.001	*****	< 0.01	< 0.01	0	Daily	Grab	
	Permit Requirement	REPORT 30-DAY AVG.	REPORT DAILY MAX	*****	0.85 30-DAY AVG.	1.20 DAILY MAX		WEEKLY	GRAB	
Arsenic	Sample Measurement	0.003	0.016	*****	0.02	0.14	0	Daily	COMP.	
	Permit Requirement	REPORT 30-DAY AVG.	REPORT DAILY MAX	*****	1.000 30-DAY AVG.	3.000 DAILY MAX		WEEKLY	COMP.	
Cadmium	Sample Measurement	< 0.0007	< 0.0007	*****	< 0.005	< 0.005	0	Daily	COMP.	
	Permit Requirement	REPORT 30-DAY AVG.	REPORT DAILY MAX	*****	0.260 30-DAY AVG.	0.890 DAILY MAX		WEEKLY	COMP.	
Chromium (Total)	Sample Measurement	< 0.0007	< 0.0007	*****	< 0.005	< 0.005	0	Daily	COMP.	
	Permit Requirement	REPORT 30-DAY AVG.	REPORT DAILY MAX	*****	0.360 30-DAY AVG.	0.230 DAILY MAX		WEEKLY	COMP.	
Copper	Sample Measurement	0.0011	0.085	*****	0.009	0.124	0	Daily	COMP.	
	Permit Requirement	REPORT 30-DAY AVG.	REPORT DAILY MAX	*****	0.360 30-DAY AVG.	1.100 DAILY MAX		WEEKLY	COMP.	
Lead	Sample Measurement	< 0.0004	< 0.0004	*****	< 0.003	< 0.003	0	Daily	COMP.	
	Permit Requirement	REPORT 30-DAY AVG.	REPORT DAILY MAX	*****	0.400 30-DAY AVG.	0.600 DAILY MAX		WEEKLY	COMP.	
NAME / TITLE OF AUTHORIZED REPRESENTATIVE John Santag, Jr. Sr. Program Mgr.		I CERTIFY UNDER PENALTY OF LAW THAT I HAVE PERSONALLY EXAMINED AND AM FAMILIAR WITH THE INFORMATION SUBMITTED IN THIS DOCUMENT AND ALL ATTACHMENTS AND THAT, BASED ON MY INQUIRY OF THOSE INDIVIDUALS IMMEDIATELY RESPONSIBLE FOR OBTAINING THE INFORMATION, I BELIEVE THE SUBMITTED INFORMATION IS TRUE, ACCURATE AND COMPLETE. I AM AWARE THAT THERE ARE SIGNIFICANT PENALTIES FOR SUBMITTING FALSE INFORMATION, INCLUDING THE POSSIBILITY OF FINE AND IMPRISONMENT.			SIGNATURE OF AUTHORIZED REPRESENTATIVE 		TELEPHONE NUMBER 732 738 3184		DATE 2006 02 25	
NAME / TITLE OF AUTHORIZED REPRESENTATIVE Sr. Program Mgr.					AREA CODE 732		NUMBER 738 3184		YEAR 2006	
					MO 02		DAY 25			

MIDDLESEX COUNTY UTILITIES AUTHORITY (MCUA)
SELF-MONITORING REPORT (SMR)

PERMITTEE NAME / ADDRESS

NAME: BIOGENESIS SEDIMENT WASHING LLC

ADDRESS: 75 CROWS MILL ROAD

KEASBEY, NEW JERSEY 08832

MCUA TDA NUMBER: 009-05 DISCHARGE POINT: DSN 001

MONITORING PERIOD: FROM 1/01/06 TO 1/31/06

PARAMETER	QUANTITY OR LOADING			QUALITY OR CONCENTRATION			# OF VIOS.	FREQUENCY OF ANALYSIS	SAMPLE TYPE
	AVERAGE	MAXIMUM	UNITS	MINIMUM	AVERAGE	MAXIMUM			
Mercury	Sample Measurement	<0.0003	<0.0003		<0.0002	<0.0002	0	Daily	COMP.
	Permit Requirement	REPORT 30-DAY AVG.	REPORT DAILY MAX	KG DAY	0.048 30-DAY AVG.	0.110 DAILY MAX		WEEKLY	COMP.
Nickel	Sample Measurement	0.005	0.380		0.037	0.552	1	Daily	COMP.
	Permit Requirement	REPORT 30-DAY AVG.	REPORT DAILY MAX	KG DAY	0.170 30-DAY AVG.	0.380 DAILY MAX		WEEKLY	COMP.
Silver	Sample Measurement	<0.0007	<0.0007		<0.005	<0.005	0	Daily	COMP.
	Permit Requirement	REPORT 30-DAY AVG.	REPORT DAILY MAX	KG DAY	0.240 30-DAY AVG.	0.430 DAILY MAX		WEEKLY	COMP.
Zinc	Sample Measurement	0.01	1.10		0.075	1.6	0	Daily	COMP.
	Permit Requirement	REPORT 30-DAY AVG.	REPORT DAILY MAX	KG DAY	0.660 30-DAY AVG.	2.200 DAILY MAX		WEEKLY	COMP.
Total Toxic Organics	Sample Measurement	<0.013	0.011		<0.100	0.093	0	Daily	COMP.
	Permit Requirement	REPORT 30-DAY AVG.	REPORT DAILY MAX	KG DAY	REPORT 30-DAY AVG.	2.13 DAILY MAX		WEEKLY	COMP / AGRAB
Volatile Organics	Sample Measurement	<0.003	0.006		<0.02	0.03	0	Daily	GRAB
	Permit Requirement	REPORT 30-DAY AVG.	REPORT DAILY MAX	KG DAY	REPORT 30-DAY AVG.	REPORT DAILY MAX		WEEKLY	GRAB
Base/Neutrals	Sample Measurement	<0.001	0.011		<0.01	0.093	0	Daily	COMP.
	Permit Requirement	REPORT 30-DAY AVG.	REPORT DAILY MAX	KG DAY	REPORT 30-DAY AVG.	REPORT DAILY MAX		WEEKLY	COMP.
<p>I CERTIFY UNDER PENALTY OF LAW THAT I HAVE PERSONALLY EXAMINED AND AM FAMILIAR WITH THE INFORMATION SUBMITTED IN THIS DOCUMENT AND ALL ATTACHMENTS AND THAT, BASED ON MY INQUIRY OF THOSE INDIVIDUALS IMMEDIATELY RESPONSIBLE FOR OBTAINING THE INFORMATION, I BELIEVE THE SUBMITTED INFORMATION IS TRUE, ACCURATE AND COMPLETE. I AM AWARE THAT THERE ARE SIGNIFICANT PENALTIES FOR SUBMITTING FALSE INFORMATION, INCLUDING THE POSSIBILITY OF FINE AND IMPRISONMENT.</p>									
NAME / TITLE OF AUTHORIZED REPRESENTATIVE		<p>Jene Sonteg, Jr. Sr. Program Mgr.</p>			<p><i>Jene Sonteg</i></p>			SIGNATURE OF AUTHORIZED REPRESENTATIVE	
		<p>732 738 3184</p>			<p>732 738 3184</p>			TELEPHONE NUMBER	
		<p>02 25</p>			<p>2006 02 25</p>			DATE	
		<p>AREA CODE</p>			<p>NUMBER</p>			YEAR MO DAY	

MIDDLESEX COUNTY UTILITIES AUTHORITY (MCUA)
SELF-MONITORING REPORT (SMR)

PERMITTEE NAME / ADDRESS: BIOGENESIS SEDIMENT WASHING LLC
 NAME: BIOGENESIS SEDIMENT WASHING LLC MCUA TDA NUMBER: 008505 DISCHARGE POINT: DSN 001
 ADDRESS: Z5 CROWS MILL ROAD MONITORING PERIOD: FROM 1/21/06 TO 1/31/06
KEASBEY, NEW JERSEY 08832

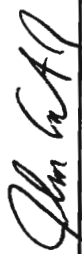
PARAMETER	QUANTITY OR LOADING			QUALITY OR CONCENTRATION			# OF VIOLATIONS	FREQUENCY OF ANALYSIS	SAMPLE TYPE
	AVERAGE	MAXIMUM	UNITS	MINIMUM	AVERAGE	MAXIMUM			
Acid Extractables	<0.00001	<0.00001	KG DAY	*****	<0.0001	<0.0001	0	Daily	COMP.
	REPORT 30-DAY AVG.	REPORT DAILY MAX		*****	REPORT 30-DAY AVG.	REPORT DAILY MAX		WEEKLY	COMP.
Pesticides	<0.001	<0.001	KG DAY	*****	<0.01	<0.01	0	Daily	COMP.
	REPORT 30-DAY AVG.	REPORT DAILY MAX		*****	<0.01 30-DAY AVG.	<0.01 DAILY MAX		WEEKLY	COMP.
PCBs	<0.026	<0.026			<0.2	<0.2	0	Daily	COMP.
I CERTIFY UNDER PENALTY OF LAW THAT I HAVE PERSONALLY EXAMINED AND AM FAMILIAR WITH THE INFORMATION SUBMITTED IN THIS DOCUMENT AND ALL ATTACHMENTS AND THAT, BASED ON MY INQUIRY OF THOSE INDIVIDUALS IMMEDIATELY RESPONSIBLE FOR OBTAINING THE INFORMATION, I BELIEVE THE SUBMITTED INFORMATION IS TRUE, ACCURATE AND COMPLETE. I AM AWARE THAT THERE ARE SIGNIFICANT PENALTIES FOR SUBMITTING FALSE INFORMATION, INCLUDING THE POSSIBILITY OF FINE AND IMPRISONMENT.									
NAME / TITLE OF AUTHORIZED REPRESENTATIVE <u>Jonn Santey, Jr.</u> <u>Sr. Program Mgr.</u>		SIGNATURE OF AUTHORIZED REPRESENTATIVE 			TELEPHONE NUMBER 732 738 3184		DATE 2006 02 25		

MIDDLESEX COUNTY UTILITIES AUTHORITY

Self-Monitoring Report
Transmittal Sheet

MCUA TDA No.: 009-05

Reporting Period: FEBRUARY 2006 through _____

Permitted facility: Name: BIOGENESIS WASHING BGW, LLC

Address: 75 CROWS MILL ROAD

KEASBEY, NEW JERSEY 08832

Telephone No.: 732 738 3284

OPERATING EXCEPTIONS

	Yes	No
Dye Testing	_____	_____X
Temporary Bypassing	_____	_____X
Monitoring Malfunctions	_____	_____X
Units Out of Operation	_____	_____X
Other	_____X	_____

(Detail any "yes" on a separate sheet of paper.)

AUTHENTICATION

I certify under penalty of law that I have personally examined and am familiar with the information submitted in this document and all attachments and that, based on my inquiry of those individuals immediately responsible for obtaining the information, I believe the submitted information is true, accurate and complete. I am aware that there are significant penalties for submitting false information including the possibility of fine and imprisonment.

Signature of Authorized Representative

3/31/2006
Date

JOHN SONTAG, JR. SR. PROG. MGR
Type or Print Name and Title of Authorized Representative

Operating Exceptions – February 1 – February 28, 2006

BGW continued daily monitoring and sampling of the wastewater discharge per the terms of the MCUA agreement. BGW experiences a lag time from the sample collection date to the return of analytical data from the lab. As soon as data are available, adjustments are made to the process to bring it in to compliance. As such, the effluent water quality exceeded daily maximum metals limits for Copper, Lead, Nickel and Zinc during the month of February.

Copper exceeded the limit of 1.1 mg/l on three of the 28 days, which resulted in a 30-day average exceedance. The metals removal chemistry was adjusted and the process brought back into compliance.

Lead exceeded the limit of 0.6 mg/l on two of the 28 days. The metals removal adjustments also worked for Lead.

Nickel exceeded the limit of 0.36 mg/l on one of the 28 days, which resulted in a 30-day average exceedance. Nickel concentrations returned to compliance level after the chemistry adjustments.

Zinc exceeded the limit of 2.2 mg/l on five of the 28 days, which resulted in a 30-day average exceedance for Zinc. Zinc concentrations dropped below the 2.2 mg/l limit following chemical adjustments.

No other parameters were exceeded during the operating month

Change were made the metals removal process by increasing pH into the metals removal clarifier and increasing dosages of coagulant and polymer to enhance precipitation. Adjustments made to the process successfully reduced the effluent metals concentration.

MIDDLESEX COUNTY UTILITIES AUTHORITY (MCUA)
SELF-MONITORING REPORT (SMR)

PERMITTEE NAME / ADDRESS: BIOGENESIS SEDIMENT WASHING LLC
 NAME: MCUA TDA NUMBER: 008-05 DISCHARGE POINT: DSN 001
 ADDRESS: 75 CROWS MILL ROAD MONITORING PERIOD: FROM 2/1/2006 TO 2/28/2006
 KEASBEY, NEW JERSEY 08832

PARAMETER	QUANTITY OR LOADING			QUALITY OR CONCENTRATION			# OF VIOLATIONS	FREQUENCY OF ANALYSIS	SAMPLE TYPE
	AVERAGE	MAXIMUM	UNITS	MINIMUM	AVERAGE	MAXIMUM			
Flow	Sample Measurement	0.051	0.153					CONT.	N/A
	Permit Requirement	0.360 30-DAY AVG.	DAILY MAX	MGD				CONTINUOUS	N/A
Flow (Total)	Sample Measurement	1.438	2.508					CONT.	N/A
	Permit Requirement	REPORT MONTHLY	38.680 TOTAL TO DATE	MG				CONTINUOUS	N/A
Flow (gpm)	Sample Measurement	35	106					CONT.	N/A
	Permit Requirement	REPORT 30-DAY AVG.	250 DAILY MAX	GPM				CONTINUOUS	N/A
pH (Grab)	Sample Measurement				6.7	7.9		DAILY	GRAB
	Permit Requirement				5.0 MINIMUM	10.0 MAXIMUM	S.U.	DAILY	GRAB
BOD, 5 DAY	Sample Measurement	5.95	23.82					WEEKLY	GRAB
	Permit Requirement	REPORT 30-DAY AVG.	REPORT DAILY MAX	KG DAY		REPORT 30-DAY AVG.		WEEKLY	GRAB
COD	Sample Measurement	45.2	217					WEEKLY	COMP.
	Permit Requirement	REPORT 30-DAY AVG.	REPORT DAILY MAX	KG DAY		REPORT 30-DAY AVG.		WEEKLY	COMP.
Total Suspended Solids (TSS)	Sample Measurement	0.74	7.64					DAILY	COMP.
	Permit Requirement	REPORT 30-DAY AVG.	REPORT DAILY MAX	KG DAY		REPORT 30-DAY AVG.		DAILY	COMP.

I CERTIFY UNDER PENALTY OF LAW THAT I HAVE PERSONALLY EXAMINED AND AM FAMILIAR WITH THE INFORMATION SUBMITTED IN THIS DOCUMENT AND ALL ATTACHMENTS AND THAT, BASED ON MY INQUIRY OF THOSE INDIVIDUALS IMMEDIATELY RESPONSIBLE FOR OBTAINING THE INFORMATION, I BELIEVE THE SUBMITTED INFORMATION IS TRUE, ACCURATE AND COMPLETE. I AM AWARE THAT THERE ARE SIGNIFICANT PENALTIES FOR SUBMITTING FALSE INFORMATION, INCLUDING THE POSSIBILITY OF FINE AND IMPRISONMENT.

NAME / TITLE OF AUTHORIZED REPRESENTATIVE: JOHN SANTAS, JR.
SR. Pres. mbr

SIGNATURE OF AUTHORIZED REPRESENTATIVE: *[Signature]*

TELEPHONE NUMBER: 732-738-3284

AREA CODE: 732 YEAR: 2006 MO: 3 DAY: 31

MIDDLESEX COUNTY UTILITIES AUTHORITY (MCUA)
SELF-MONITORING REPORT (SMR)

PERMITTEE NAME / ADDRESS

NAME: BIOGENESIS SEDIMENT WASHING I.L.C.

ADDRESS: 75 CROWS MILL ROAD

KEASBEY, NEW JERSEY 08832

MCUA TDA NUMBER: 008-05

DISCHARGE POINT: DSN.001

MONITORING PERIOD: FROM 2/1/2006 TO 2/28/2006

PARAMETER	QUANTITY OR LOADING			QUALITY OR CONCENTRATION			# OF VIOLATIONS	FREQUENCY OF ANALYSIS	SAMPLE TYPE
	AVERAGE	MAXIMUM	UNITS	MINIMUM	AVERAGE	MAXIMUM			
Total Petroleum Hydrocarbons	Sample Measurement	<0.972	<0.972		*****	<5		DAILY	GRAB
	Permit Requirement	REPORT 30-DAY AVG.	REPORT DAILY MAX	KG DAY	*****	100 30-DAY AVG.	150 DAILY MAX	WEEKLY	GRAB
Cyanide (Total)	Sample Measurement	<0.002	<0.002		*****	<0.01		DAILY	GRAB
	Permit Requirement	REPORT 30-DAY AVG.	REPORT DAILY MAX	KG DAY	*****	0.65 30-DAY AVG.	1.20 DAILY MAX	WEEKLY	GRAB
Arsenic	Sample Measurement	0.002	0.0125		*****	0.010	0.022	DAILY	COMP.
	Permit Requirement	REPORT 30-DAY AVG.	REPORT DAILY MAX	KG DAY	*****	1.000 30-DAY AVG.	3.000 DAILY MAX	WEEKLY	COMP.
Cadmium	Sample Measurement	0.002	0.0122		*****	0.009	0.021	DAILY	COMP.
	Permit Requirement	REPORT 30-DAY AVG.	REPORT DAILY MAX	KG DAY	*****	0.260 30-DAY AVG.	0.680 DAILY MAX	WEEKLY	COMP.
Chromium (Total)	Sample Measurement	0.006	0.0022		*****	0.003	0.005	DAILY	COMP.
	Permit Requirement	REPORT 30-DAY AVG.	REPORT DAILY MAX	KG DAY	*****	0.360 30-DAY AVG.	0.230 DAILY MAX	WEEKLY	COMP.
Copper	Sample Measurement	0.094	0.773		*****	0.483	1.33	DAILY	COMP.
	Permit Requirement	REPORT 30-DAY AVG.	REPORT DAILY MAX	KG DAY	*****	0.360 30-DAY AVG.	1.100 DAILY MAX	WEEKLY	COMP.
Lead	Sample Measurement	0.058	0.427		*****	0.297	0.798	DAILY	COMP.
	Permit Requirement	REPORT 30-DAY AVG.	REPORT DAILY MAX	KG DAY	*****	0.400 30-DAY AVG.	0.600 DAILY MAX	WEEKLY	COMP.
<p>I CERTIFY UNDER PENALTY OF LAW THAT I HAVE PERSONALLY EXAMINED AND AM FAMILIAR WITH THE INFORMATION SUBMITTED IN THIS DOCUMENT AND ALL ATTACHMENTS AND THAT, BASED ON MY INQUIRY OF THOSE INDIVIDUALS IMMEDIATELY RESPONSIBLE FOR OBTAINING THE INFORMATION, I BELIEVE THE SUBMITTED INFORMATION IS TRUE, ACCURATE AND COMPLETE. I AM AWARE THAT THERE ARE SIGNIFICANT PENALTIES FOR SUBMITTING FALSE INFORMATION, INCLUDING THE POSSIBILITY OF FINE AND IMPRISONMENT.</p>									
<p>John Sontag, Jr. Sr. Program Mgr.</p>								<p>732 738-3384</p>	
<p>NAME / TITLE OF AUTHORIZED REPRESENTATIVE</p>								<p>DATE</p>	
<p>SIGNATURE OF AUTHORIZED REPRESENTATIVE</p>								<p>YEAR MO DAY</p>	
<p>AREA CODE NUMBER</p>								<p>2006 3 31</p>	

MIDDLESEX COUNTY UTILITIES AUTHORITY (MCUA)
SELF-MONITORING REPORT (SMR)

PERMITTEE NAME / ADDRESS: BIOGENESIS SEDIMENT WASHING LLC
 NAME: 75 CROWS MILL ROAD
 ADDRESS: KEASBEY, NEW JERSEY 08832
 MCUA TDA NUMBER: 009-05 DISCHARGE POINT: DSN 001
 MONITORING PERIOD: FROM 2/1/2006 TO 2/28/2006

PARAMETER	QUANTITY OR LOADING		QUALITY OR CONCENTRATION			# OF VIOLATIONS	FREQUENCY OF ANALYSIS	SAMPLE TYPE	
	AVERAGE	MAXIMUM	UNITS	MINIMUM	AVERAGE				MAXIMUM
Mercury	Sample Measurement	<0.00001	<0.00002	KG DAY	*****	<0.0001	<0.0002	DAILY	COMP.
	Permit Requirement	REPORT 30-DAY AVG.	REPORT DAILY MAX		*****	0.048 30-DAY AVG.	0.110 DAILY MAX	WEEKLY	COMP.
Nickel	Sample Measurement	0.04	0.10	KG DAY	*****	0.210	0.427	DAILY	COMP.
	Permit Requirement	REPORT 30-DAY AVG.	REPORT DAILY MAX		*****	0.170 30-DAY AVG.	0.360 DAILY MAX	WEEKLY	COMP.
Silver	Sample Measurement	<0.0008	<0.001	KG DAY	*****	<0.004	<0.005	DAILY	COMP.
	Permit Requirement	REPORT 30-DAY AVG.	REPORT DAILY MAX		*****	0.240 30-DAY AVG.	0.430 DAILY MAX	WEEKLY	COMP.
Zinc	Sample Measurement	0.358	1.88	KG DAY	*****	1.84	4.24	DAILY	COMP.
	Permit Requirement	REPORT 30-DAY AVG.	REPORT DAILY MAX		*****	0.660 30-DAY AVG.	2.200 DAILY MAX	WEEKLY	COMP.
Total Toxic Organics	Sample Measurement	<0.002	<0.002	KG DAY	*****	<0.01	<0.01	DAILY	COMP.
	Permit Requirement	REPORT 30-DAY AVG.	REPORT DAILY MAX		*****	REPORT 30-DAY AVG.	2.13 DAILY MAX	WEEKLY	COMP./GRAB
Volatile Organics	Sample Measurement	<0.004	<0.004	KG DAY	*****	<0.02	<0.02	DAILY	GRAB
	Permit Requirement	REPORT 30-DAY AVG.	REPORT DAILY MAX		*****	REPORT 30-DAY AVG.	REPORT DAILY MAX	WEEKLY	GRAB
Base/Neutrals	Sample Measurement	<0.002	<0.002	KG DAY	*****	<0.01	<0.01	DAILY	COMP.
	Permit Requirement	REPORT 30-DAY AVG.	REPORT DAILY MAX		*****	REPORT 30-DAY AVG.	REPORT DAILY MAX	WEEKLY	COMP.

I CERTIFY UNDER PENALTY OF LAW THAT I HAVE PERSONALLY EXAMINED AND AM FAMILIAR WITH THE INFORMATION SUBMITTED IN THIS DOCUMENT AND ALL ATTACHMENTS AND THAT, BASED ON MY INQUIRY OF THOSE INDIVIDUALS IMMEDIATELY RESPONSIBLE FOR OBTAINING THE INFORMATION, I BELIEVE THE SUBMITTED INFORMATION IS TRUE, ACCURATE AND COMPLETE. I AM AWARE THAT THERE ARE SIGNIFICANT PENALTIES FOR SUBMITTING FALSE INFORMATION, INCLUDING THE POSSIBILITY OF FINE AND IMPRISONMENT.

NAME / TITLE OF AUTHORIZED REPRESENTATIVE: Jonn Sontag, Jr.
S.E. Prag, Mgr.
 SIGNATURE OF AUTHORIZED REPRESENTATIVE: *Jonn Sontag*
 TELEPHONE NUMBER: 732-738-3284
 AREA CODE: 732
 DATE: 2006 3 31

MIDDLESEX COUNTY UTILITIES AUTHORITY (MCUA)
SELF-MONITORING REPORT (SMR)

PERMITTEE NAME / ADDRESS
 NAME: BIOGENESIS SEDIMENT WASHINGTON
 ADDRESS: 75 CROWS MILL ROAD
 KEASBEY, NEW JERSEY 08832

MCUA TDA NUMBER: 002-05 DISCHARGE POINT: DSN.001
 MONITORING PERIOD: FROM 2/1/2006 TO 2/28/2006

PARAMETER	QUANTITY OR LOADING		QUALITY OR CONCENTRATION		# OF VIOLATIONS	FREQUENCY OF ANALYSIS	SAMPLE TYPE
	AVERAGE	MAXIMUM	MINIMUM	MAXIMUM			
Acid Extractables	<0.0002	<0.0002	*****	<0.0001		DAILY	Comp.
	REPORT 30-DAY AVG.	REPORT DAILY MAX	*****	REPORT 30-DAY AVG.	MG L	WEEKLY	COMP.
Pesticides/Pods	<0.001	<0.001	*****	<0.01		DAILY	Comp.
	REPORT 30-DAY AVG.	REPORT DAILY MAX	*****	<0.01 DAILY MAX	PPB	WEEKLY	COMP.
-PCBs	<0.026	<0.026	-	<0.2		DAILY	Comp.
	30-DAY AVG	DAILY MAX	-	DAILY MAX	PPB		
<p>I CERTIFY UNDER PENALTY OF LAW THAT I HAVE PERSONALLY EXAMINED AND AM FAMILIAR WITH THE INFORMATION SUBMITTED IN THIS DOCUMENT AND ALL ATTACHMENTS AND THAT, BASED ON MY INQUIRY OF THOSE INDIVIDUALS IMMEDIATELY RESPONSIBLE FOR OBTAINING THE INFORMATION, I BELIEVE THE SUBMITTED INFORMATION IS TRUE, ACCURATE AND COMPLETE. I AM AWARE THAT THERE ARE SIGNIFICANT PENALTIES FOR SUBMITTING FALSE INFORMATION, INCLUDING THE POSSIBILITY OF FINE AND IMPRISONMENT.</p>							
NAME / TITLE OF AUTHORIZED REPRESENTATIVE John Sentes Jr Sr. Proj MGR		SIGNATURE OF AUTHORIZED REPRESENTATIVE 		TELEPHONE NUMBER 732 738-3284		DATE 2006 3 31	
				AREA CODE 732		YEAR 2006	
						MO 3	
						DAY 31	

MIDDLESEX COUNTY UTILITIES AUTHORITY

Self-Monitoring Report
Transmittal Sheet

MCUA TDA No.: 009-05

Reporting Period: March 1, 2006 through March 31, 2006

Permitted facility: Name: BioGenesis Washing BGW, LLC
Address: 75 Crows Mill Road
Keasbey, N.J. 08832
Telephone No.: 732-738-3284

OPERATING EXCEPTIONS

	Yes	No
Dye Testing	_____	_____✓
Temporary Bypassing	_____	_____✓
Monitoring Malfunctions	_____	_____✓
Units Out of Operation	_____	_____✓
Other (Detail any "yes" on a separate sheet of paper.)	_____	_____✓

AUTHENTICATION

I certify under penalty of law that I have personally examined and am familiar with the information submitted in this document and all attachments and that, based on my inquiry of those individuals immediately responsible for obtaining the information, I believe the submitted information is true, accurate and complete. I am aware that there are significant penalties for submitting false information including the possibility of fine and imprisonment.

Signature of Authorized Representative

April 25, 2006
Date

John Sontag, Jr.
Sr. Program Manager
Type or Print Name and Title of Authorized Representative

MIDDLESEX COUNTY UTILITIES AUTHORITY (MCUA)
SELF-MONITORING REPORT (SMR)

PERMITTEE NAME / ADDRESS

NAME: BIOGENESIS SEDIMENT WASHING LLC

ADDRESS: Z5 CROWS MILL ROAD

KEASBEY, NEW JERSEY 08832

MCUA TDA NUMBER: 009-05

DISCHARGE POINT: DSNJ001

MONITORING PERIOD: FROM 3-1-2006 TO 3-31-2006

PARAMETER	QUANTITY OR LOADING			QUALITY OR CONCENTRATION			# OF VIOLATIONS	FREQUENCY OF ANALYSIS	SAMPLE TYPE
	AVERAGE	MAXIMUM	UNITS	MINIMUM	AVERAGE	MAXIMUM			
Flow	Sample Measurement	0.026	0.126		*****	*****	0	CONT.	
	Permit Requirement	0.360 30-DAY AVG.	DAILY MAX	MGD	*****	*****		CONTINUOUS	N/A
Flow (Total)	Sample Measurement	0.794	3.278		*****	*****	0	CONT.	
	Permit Requirement	REPORT MONTHLY	38,880 TOTAL TO DATE	MG	*****	*****		CONTINUOUS	N/A
Flow (gpm)	Sample Measurement	18	88		*****	*****	0	CONT.	
	Permit Requirement	REPORT 30-DAY AVG.	250 DAILY MAX	GPM	*****	*****		CONTINUOUS	N/A
pH (Grab)	Sample Measurement	*****	*****		6.9	8.8	0	DAILY	GRAB
	Permit Requirement	*****	*****	...	5.0 MINIMUM	10.0 MAXIMUM		DAILY	GRAB
BOD, 5 DAY	Sample Measurement	9.32	24.18		*****	24.8	0	Weekly	GRAB
	Permit Requirement	REPORT 30-DAY AVG.	REPORT DAILY MAX	KG DAY	*****	REPORT 30-DAY AVG.		WEEKLY	GRAB
COD	Sample Measurement	11.42	337		*****	118	0	Weekly	Comp.
	Permit Requirement	REPORT 30-DAY AVG.	REPORT DAILY MAX	KG DAY	*****	REPORT 30-DAY AVG.		WEEKLY	COMP.
Total Suspended Solids (TSS)	Sample Measurement	0.08	0.67		*****	0.85	0	Daily	COMP.
	Permit Requirement	REPORT 30-DAY AVG.	REPORT DAILY MAX	KG DAY	*****	REPORT 30-DAY AVG.		DAILY	COMP.
<p>I CERTIFY UNDER PENALTY OF LAW THAT I HAVE PERSONALLY EXAMINED AND AM FAMILIAR WITH THE INFORMATION SUBMITTED IN THIS DOCUMENT AND ALL ATTACHMENTS AND THAT, BASED ON MY INQUIRY OF THOSE INDIVIDUALS IMMEDIATELY RESPONSIBLE FOR OBTAINING THE INFORMATION, I BELIEVE THE SUBMITTED INFORMATION IS TRUE, ACCURATE AND COMPLETE. I AM AWARE THAT THERE ARE SIGNIFICANT PENALTIES FOR SUBMITTING FALSE INFORMATION, INCLUDING THE POSSIBILITY OF FINE AND IMPRISONMENT.</p>									
NAME / TITLE OF AUTHORIZED REPRESENTATIVE John Santeg, Jr. Sr. Program Mgr		SIGNATURE OF AUTHORIZED REPRESENTATIVE 			TELEPHONE 732 738 3284		DATE 2006 04 25		

ATTACH COMMENTS AND EXPLANATIONS OF ANY VIOLATIONS

MIDDLESEX COUNTY UTILITIES AUTHORITY (MCUA)
SELF-MONITORING REPORT (SMR)

PERMITTEE NAME / ADDRESS

NAME: BIOGENESIS SEDIMENT WASHING LLC

ADDRESS: 75 CROWS MILL ROAD

KEASBEY, NEW JERSEY 08832

MCUA TDA NUMBER: 009-05

DISCHARGE POINT: DSN 001

MONITORING PERIOD: FROM 3-1-2006 TO 3-31-2006

PARAMETER	QUANTITY OR LOADING			QUALITY OR CONCENTRATION			# OF VIOLATIONS	FREQUENCY OF ANALYSIS	SAMPLE TYPE		
	AVERAGE	MAXIMUM	UNITS	MINIMUM	AVERAGE	MAXIMUM				UNITS	
Total Petroleum Hydrocarbons	Sample Measurement	<0.193	1.75		<1.666	16.7	0	Weekly	GRAB		
	Permit Requirement	REPORT 30-DAY AVG.	REPORT DAILY MAX	KG DAY	100 30-DAY AVG.	150 DAILY MAX		WEEKLY	GRAB		
Cyanide (Total)	Sample Measurement	<0.002	<0.002		<0.01	<0.01	0	Weekly	GRAB		
	Permit Requirement	REPORT 30-DAY AVG.	REPORT DAILY MAX	KG DAY	0.65 30-DAY AVG.	1.20 DAILY MAX		WEEKLY	GRAB		
Arsenic	Sample Measurement	<0.002	<0.002		<0.01	<0.01	0	Weekly	COMP		
	Permit Requirement	REPORT 30-DAY AVG.	REPORT DAILY MAX	KG DAY	1.000 30-DAY AVG.	3.000 DAILY MAX		WEEKLY	COMP.		
Cadmium	Sample Measurement	<0.0022	<0.0022		<0.005	<0.005	0	Weekly	COMP		
	Permit Requirement	REPORT 30-DAY AVG.	REPORT DAILY MAX	KG DAY	0.260 30-DAY AVG.	0.680 DAILY MAX		WEEKLY	COMP.		
Chromium (Total)	Sample Measurement	<0.0022	<0.0022		<0.005	<0.005	0	Weekly	COMP		
	Permit Requirement	REPORT 30-DAY AVG.	REPORT DAILY MAX	KG DAY	0.360 30-DAY AVG.	0.230 DAILY MAX		WEEKLY	COMP.		
Copper	Sample Measurement	0.0014	0.064		0.012	0.357	0	Weekly	COMP		
	Permit Requirement	REPORT 30-DAY AVG.	REPORT DAILY MAX	KG DAY	0.360 30-DAY AVG.	1.100 DAILY MAX		WEEKLY	COMP.		
Lead	Sample Measurement	0.0007	0.007		0.006	0.039	0	Weekly	COMP		
	Permit Requirement	REPORT 30-DAY AVG.	REPORT DAILY MAX	KG DAY	0.400 30-DAY AVG.	0.600 DAILY MAX		WEEKLY	COMP.		
I CERTIFY UNDER PENALTY OF LAW THAT I HAVE PERSONALLY EXAMINED AND AM FAMILIAR WITH THE INFORMATION SUBMITTED IN THIS DOCUMENT AND ALL ATTACHMENTS AND THAT, BASED ON MY INQUIRY OF THOSE INDIVIDUALS IMMEDIATELY RESPONSIBLE FOR OBTAINING THE INFORMATION, I BELIEVE THE SUBMITTED INFORMATION IS TRUE, ACCURATE AND COMPLETE. I AM AWARE THAT THERE ARE SIGNIFICANT PENALTIES FOR SUBMITTING FALSE INFORMATION, INCLUDING THE POSSIBILITY OF FINE AND IMPRISONMENT.											
NAME / TITLE OF AUTHORIZED REPRESENTATIVE John Sontag, Jr. Sr. Program Mgr.								TELEPHONE 732 738-3284		DATE 2006 04 25	
SIGNATURE OF AUTHORIZED REPRESENTATIVE 								AREA CODE 732		NUMBER 738-3284	

ATTACH COMMENTS AND EXPLANATIONS OF ANY VIOLATIONS

FORM: SMR 2.1 REVISION: 5/02

PAGE 2 OF 4

MIDDLESEX COUNTY UTILITIES AUTHORITY (MCUA)
SELF-MONITORING REPORT (SMR)

PERMITTEE NAME / ADDRESS: KEASBEY, NEW JERSEY_08832
 NAME: BIOGENESIS SEDIMENT WASHING LLC
 ADDRESS: Z5 CROWS MILL ROAD
 MCUA TDA NUMBER: 009-05 DISCHARGE POINT: DSN 001
 MONITORING PERIOD: FROM 3-1-2006 TO 3-31-2006

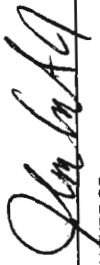
PARAMETER	QUANTITY OR LOADING			QUALITY OR CONCENTRATION			# OF VIOS.	FREQUENCY OF ANALYSIS	SAMPLE TYPE
	AVERAGE	MAXIMUM	UNITS	MINIMUM	AVERAGE	MAXIMUM			
Mercury	Sample Measurement	<0.0001	<0.0002		<0.0002	<0.0002		Weekly	Comp
	Permit Requirement	REPORT 30-DAY AVG.	REPORT DAILY MAX	KG DAY	0.048 30-DAY AVG.	MG L	Weekly	COMP.
Nickel	Sample Measurement	0.0087	0.0418		0.075	0.361		Weekly	Comp
	Permit Requirement	REPORT 30-DAY AVG.	REPORT DAILY MAX	KG DAY	0.170 30-DAY AVG.	MG L	Weekly	COMP.
Silver	Sample Measurement	<0.0008	<0.001		<0.005	<0.005		Weekly	Comp
	Permit Requirement	REPORT 30-DAY AVG.	REPORT DAILY MAX	KG DAY	0.240 30-DAY AVG.	MG L	Weekly	COMP.
Zinc	Sample Measurement	0.0087	0.1830		0.075	1.02		Weekly	Comp
	Permit Requirement	REPORT 30-DAY AVG.	REPORT DAILY MAX	KG DAY	0.660 30-DAY AVG.	MG L	Weekly	COMP.
Total Toxic Organics	Sample Measurement	<0.0087	<0.0087		<0.076	<0.076		Weekly	Comp
	Permit Requirement	REPORT 30-DAY AVG.	REPORT DAILY MAX	KG DAY	2.13 30-DAY AVG.	MG L	Weekly	COMP / GRAB
Volatile Organics	Sample Measurement	<0.004	<0.004		<0.02	<0.03		Weekly	GRAB
	Permit Requirement	REPORT 30-DAY AVG.	REPORT DAILY MAX	KG DAY	REPORT 30-DAY AVG.	MG L	Weekly	GRAB
Base/Neutrals	Sample Measurement	<0.002	<0.002		<0.01	<0.076		Weekly	Comp
	Permit Requirement	REPORT 30-DAY AVG.	REPORT DAILY MAX	KG DAY	REPORT 30-DAY AVG.	MG L	Weekly	COMP.
I CERTIFY UNDER PENALTY OF LAW THAT I HAVE PERSONALLY EXAMINED AND AM FAMILIAR WITH THE INFORMATION SUBMITTED IN THIS DOCUMENT AND ALL ATTACHMENTS AND THAT, BASED ON MY INQUIRY OF THOSE INDIVIDUALS IMMEDIATELY RESPONSIBLE FOR OBTAINING THE INFORMATION, I BELIEVE THE SUBMITTED INFORMATION IS TRUE, ACCURATE AND COMPLETE. I AM AWARE THAT THERE ARE SIGNIFICANT PENALTIES FOR SUBMITTING FALSE INFORMATION, INCLUDING THE POSSIBILITY OF FINE AND IMPRISONMENT.				SIGNATURE OF AUTHORIZED REPRESENTATIVE 		TELEPHONE 732 738 3284		DATE 2006 04 25	
NAME / TITLE OF AUTHORIZED REPRESENTATIVE John Santeg Jr. Sr. Program Mgr				AREA CODE 732		NUMBER 738 3284		YEAR 2006	
								MO 04	
								DAY 25	

MIDDLESEX COUNTY UTILITIES AUTHORITY

Self-Monitoring Report
Transmittal Sheet

MCUA TDA No.: 009-05

Reporting Period: April 1, 2006 through April 30, 2006

Permitted facility: Name: BioGenesis Washing BGW, LLC.
Address: 75 Crows Mill Rd
Kearney, NJ, 08832
Telephone No.: 732 738 3284

OPERATING EXCEPTIONS

	Yes	No
Dye Testing	<u> </u>	<u> X </u>
Temporary Bypassing	<u> </u>	<u> X </u>
Monitoring Malfunctions	<u> </u>	<u> X </u>
Units Out of Operation	<u> </u>	<u> X </u>
Other	<u> </u>	<u> X </u>

(Detail any "yes" on a separate sheet of paper.)

AUTHENTICATION

I certify under penalty of law that I have personally examined and am familiar with the information submitted in this document and all attachments and that, based on my inquiry of those individuals immediately responsible for obtaining the information, I believe the submitted information is true, accurate and complete. I am aware that there are significant penalties for submitting false information including the possibility of fine and imprisonment.

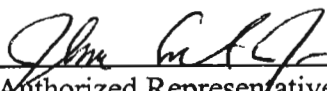
Signature of Authorized Representative

5/30/2006
Date

John Sontag, Jr. Sr. Program Mgr.
Type or Print Name and Title of Authorized Representative

MIDDLESEX COUNTY UTILITIES AUTHORITY (MCUA)
SELF-MONITORING REPORT (SMR)

PERMITTEE NAME / ADDRESS

NAME: BIOGENESIS SEDIMENT WASHING, LLC

ADDRESS: 75 CROWS MILL ROAD
KEASBEY, NEW JERSEY 08832

MCUA TDA NUMBER: 009-05 DISCHARGE POINT: DSN 001

MONITORING PERIOD: FROM 4/1/2006 TO 4/30/2006

PARAMETER	QUANTITY OR LOADING			QUALITY OR CONCENTRATION			# OF VIOLATIONS	FREQUENCY OF ANALYSIS	SAMPLE TYPE
	AVERAGE	MAXIMUM	UNITS	MINIMUM	AVERAGE	MAXIMUM			
Flow	Sample Measurement	0.067	0.177	0	Cont.	
	Permit Requirement	0.360 30-DAY AVG.	DAILY MAX		CONTINUOUS	N/A
Flow (Total)	Sample Measurement	2.0	5.34	0	Cont.	
	Permit Requirement	REPORT MONTHLY	38,880 TOTAL TO DATE		CONTINUOUS	N/A
Flow (gpm)	Sample Measurement	46	123	0	Cont.	
	Permit Requirement	REPORT 30-DAY AVG.	250 DAILY MAX		CONTINUOUS	N/A
pH (Grab)	Sample Measurement	6.8	7.8	0	DAILY	GRAB
	Permit Requirement	5.0 MINIMUM	10.0 MAXIMUM		DAILY	GRAB
BOD, 5 DAY	Sample Measurement	20.01	25.0	79.5	90.0	0	Weekly	GRAB
	Permit Requirement	REPORT 30-DAY AVG.	REPORT DAILY MAX	REPORT 30-DAY AVG.	REPORT DAILY MAX		WEEKLY	GRAB
COD	Sample Measurement	63.0	81.6	250	294	0	Weekly	COMP
	Permit Requirement	REPORT 30-DAY AVG.	REPORT DAILY MAX	REPORT 30-DAY AVG.	REPORT DAILY MAX		WEEKLY	COMP
Total Suspended Solids (TSS)	Sample Measurement	0.96	2.6	3.8	9.2	0	Weekly	COMP
	Permit Requirement	REPORT 30-DAY AVG.	REPORT DAILY MAX	REPORT 30-DAY AVG.	REPORT DAILY MAX		DAILY	COMP
NAME / TITLE OF AUTHORIZED REPRESENTATIVE		SIGNATURE OF AUTHORIZED REPRESENTATIVE			TELEPHONE		DATE		
John Santag, Jr. Sr. Program Manager		<i>John Santag</i>			732 738 3284		05/30/06		
NAME / TITLE OF AUTHORIZED REPRESENTATIVE		AREA CODE		NUMBER		YEAR		DAY	
		732		738 3284		06		30	

I CERTIFY UNDER PENALTY OF LAW THAT I HAVE PERSONALLY EXAMINED AND AM FAMILIAR WITH THE INFORMATION SUBMITTED IN THIS DOCUMENT AND ALL ATTACHMENTS AND THAT, BASED ON MY INQUIRY OF THOSE INDIVIDUALS IMMEDIATELY RESPONSIBLE FOR OBTAINING THE INFORMATION, I BELIEVE THE SUBMITTED INFORMATION IS TRUE, ACCURATE AND COMPLETE. I AM AWARE THAT THERE ARE SIGNIFICANT PENALTIES FOR SUBMITTING FALSE INFORMATION, INCLUDING THE POSSIBILITY OF FINE AND IMPRISONMENT.

MIDDLESEX COUNTY UTILITIES AUTHORITY (MCUA)
SELF-MONITORING REPORT (SMR)

PERMITTEE NAME / ADDRESS

NAME: BIOGENESIS SEDIMENT WASHING LLC

ADDRESS: 75 CROWS MILL ROAD

MCUA TDA NUMBER: 009-05

DISCHARGE POINT: DSN 001

KEASBEY, NEW JERSEY 08832

MONITORING PERIOD: FROM 4/1/2006 TO 4/30/2006

4/30/2006

PARAMETER	QUANTITY OR LOADING			QUALITY OR CONCENTRATION			# OF VIOLATIONS	FREQUENCY OF ANALYSIS	SAMPLE TYPE
	AVERAGE	MAXIMUM	UNITS	MINIMUM	AVERAGE	MAXIMUM			
Total Petroleum Hydrocarbons	Sample Measurement	1.02	2.97		4.05	10.7		Weekly	GRAB
	Permit Requirement	REPORT 30-DAY AVG.	REPORT DAILY MAX	KG DAY	100 30-DAY AVG.	150 DAILY MAX	MG L	WEEKLY	GRAB
Cyanide (Total)	Sample Measurement	0.013	0.13		0.053	0.19		Weekly	GRAB
	Permit Requirement	REPORT 30-DAY AVG.	REPORT DAILY MAX	KG DAY	0.65 30-DAY AVG.	1.20 DAILY MAX	MG L	WEEKLY	GRAB
Arsenic	Sample Measurement	<0.001	<0.002		<0.005	<0.01		Weekly	COMP
	Permit Requirement	REPORT 30-DAY AVG.	REPORT DAILY MAX	KG DAY	1.000 30-DAY AVG.	3.000 DAILY MAX	MG L	WEEKLY	COMP
Cadmium	Sample Measurement	<0.008	<0.001		<0.003	<0.005		Weekly	COMP
	Permit Requirement	REPORT 30-DAY AVG.	REPORT DAILY MAX	KG DAY	0.260 30-DAY AVG.	0.690 DAILY MAX	MG L	WEEKLY	COMP
Chromium (Total)	Sample Measurement	<0.0005	<0.001		<0.002	<0.005		Weekly	COMP
	Permit Requirement	REPORT 30-DAY AVG.	REPORT DAILY MAX	KG DAY	0.360 30-DAY AVG.	0.230 DAILY MAX	MG L	WEEKLY	COMP
Copper	Sample Measurement	<0.003	<0.006		<0.012	<0.025		Weekly	COMP
	Permit Requirement	REPORT 30-DAY AVG.	REPORT DAILY MAX	KG DAY	0.360 30-DAY AVG.	1.100 DAILY MAX	MG L	WEEKLY	COMP
Lead	Sample Measurement	<0.001	<0.001		<0.004	<0.005		Weekly	COMP
	Permit Requirement	REPORT 30-DAY AVG.	REPORT DAILY MAX	KG DAY	0.400 30-DAY AVG.	0.600 DAILY MAX	MG L	WEEKLY	COMP
<p>I CERTIFY UNDER PENALTY OF LAW THAT I HAVE PERSONALLY EXAMINED AND AM FAMILIAR WITH THE INFORMATION SUBMITTED IN THIS DOCUMENT AND ALL ATTACHMENTS AND THAT, BASED ON MY INQUIRY OF THOSE INDIVIDUALS IMMEDIATELY RESPONSIBLE FOR OBTAINING THE INFORMATION, I BELIEVE THE SUBMITTED INFORMATION IS TRUE, ACCURATE AND COMPLETE. I AM AWARE THAT THERE ARE SIGNIFICANT PENALTIES FOR SUBMITTING FALSE INFORMATION, INCLUDING THE POSSIBILITY OF FINE AND IMPRISONMENT.</p>									
<p><i>Jana Sentes, Jr.</i> Sr. Program Manager</p>								<p>TELEPHONE: 732 738-3284</p>	
<p>NAME / TITLE OF AUTHORIZED REPRESENTATIVE</p>								<p>DATE: 2006 05 30</p>	
<p>SIGNATURE OF AUTHORIZED REPRESENTATIVE</p>								<p>AREA CODE: 732 NUMBER: 738-3284</p>	

MIDDLESEX COUNTY UTILITIES AUTHORITY (MCUA)
SELF-MONITORING REPORT (SMR)

PERMITTEE NAME / ADDRESS

NAME: BIOGENESIS SEDIMENT WASHING LLC

MCUA TDA NUMBER: 009-05

DISCHARGE POINT: DSN001

ADDRESS: 75 CROWS MILL ROAD

MONITORING PERIOD: FROM 4/1/2006 TO 4/30/2006

KEASBEY, NEW JERSEY 08832

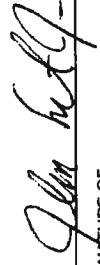
PARAMETER	QUANTITY OR LOADING		QUALITY OR CONCENTRATION				# OF VIOLATIONS	FREQUENCY OF ANALYSIS	SAMPLE TYPE	
	AVERAGE	MAXIMUM	UNITS	MINIMUM	AVERAGE	MAXIMUM				UNITS
Mercury	Sample Measurement	<0.00001	<0.00002	<0.0001	<0.002	MG L	0	Weekly	Comp
	Permit Requirement	REPORT 30-DAY AVG.	REPORT DAILY MAX	0.048 30-DAY AVG.	0.110 DAILY MAX	MG L		WEEKLY	COMP.
Nickel	Sample Measurement	0.009	0.029	0.038	0.093	MG L	0	Weekly	Comp
	Permit Requirement	REPORT 30-DAY AVG.	REPORT DAILY MAX	0.170 30-DAY AVG.	0.360 DAILY MAX	MG L		WEEKLY	COMP.
Silver	Sample Measurement	<0.0008	<0.001	<0.004	<0.005	MG L	0	Weekly	Comp
	Permit Requirement	REPORT 30-DAY AVG.	REPORT DAILY MAX	0.240 30-DAY AVG.	0.430 DAILY MAX	MG L		WEEKLY	COMP.
Zinc	Sample Measurement	<0.005	<0.001	<0.018	<0.040	MG L	0	Weekly	Comp
	Permit Requirement	REPORT 30-DAY AVG.	REPORT DAILY MAX	0.660 30-DAY AVG.	2.200 DAILY MAX	MG L		WEEKLY	COMP.
Total Toxic Organics	Sample Measurement	<0.019	<0.019	<0.076	<0.076	MG L	0	Weekly	Comp
	Permit Requirement	REPORT 30-DAY AVG.	REPORT DAILY MAX	REPORT 30-DAY AVG.	2.13 DAILY MAX	MG L		WEEKLY	COMP / GRAB
Volatile Organics	Sample Measurement	<0.005	<0.007	<0.002	<0.003	MG L	0	Weekly	GRAB
	Permit Requirement	REPORT 30-DAY AVG.	REPORT DAILY MAX	REPORT 30-DAY AVG.	REPORT DAILY MAX	MG L		WEEKLY	GRAB
Base/Neutrals	Sample Measurement	<0.003	<0.019	<0.001	<0.076	MG L	0	Weekly	Comp
	Permit Requirement	REPORT 30-DAY AVG.	REPORT DAILY MAX	REPORT 30-DAY AVG.	REPORT DAILY MAX	MG L		WEEKLY	COMP.
NAME / TITLE OF AUTHORIZED REPRESENTATIVE John Sontag, Jr. Sr. Program Mgr.		SIGNATURE OF AUTHORIZED REPRESENTATIVE 		TELEPHONE 732 738-3284		DATE 2006 05 30				

I CERTIFY UNDER PENALTY OF LAW THAT I HAVE PERSONALLY EXAMINED AND AM FAMILIAR WITH THE INFORMATION SUBMITTED IN THIS DOCUMENT AND ALL ATTACHMENTS AND THAT, BASED ON MY INQUIRY OF THOSE INDIVIDUALS IMMEDIATELY RESPONSIBLE FOR OBTAINING THE INFORMATION, I BELIEVE THE SUBMITTED INFORMATION IS TRUE, ACCURATE AND COMPLETE. I AM AWARE THAT THERE ARE SIGNIFICANT PENALTIES FOR SUBMITTING FALSE INFORMATION, INCLUDING THE POSSIBILITY OF FINE AND IMPRISONMENT.

FINAL - DISCONNECTED
MAY 17, 2006

MIDDLESEX COUNTY UTILITIES AUTHORITY

Self-Monitoring Report
Transmittal Sheet

MCUA TDA No.: 002-05

Reporting Period: MAY 1, 2006 through MAY 31, 2006

Permitted facility: Name: BioGenesis Wastng, BGW LLC
Address: 75 Crows Mill Rd.
Keasbey, NJ
Telephone No.: 732-738-3284

OPERATING EXCEPTIONS

	Yes	No
Dye Testing	<u> </u>	<u>X</u>
Temporary Bypassing	<u> </u>	<u>X</u>
Monitoring Malfunctions	<u> </u>	<u>X</u>
Units Out of Operation	<u> </u>	<u>X</u>
Other (Detail any "yes" on a separate sheet of paper.)	<u>X</u>	<u> </u>

AUTHENTICATION

I certify under penalty of law that I have personally examined and am familiar with the information submitted in this document and all attachments and that, based on my inquiry of those individuals immediately responsible for obtaining the information, I believe the submitted information is true, accurate and complete. I am aware that there are significant penalties for submitting false information including the possibility of fine and imprisonment.

John Santag, Jr.
Signature of Authorized Representative

6/28/2006
Date

John Santag, Jr. Sr. Program Mgr.
Type or Print Name and Title of Authorized Representative

Operating Exceptions – May 1 – May 31, 2006

BGW continued weekly monitoring and sampling of the wastewater discharge per the terms of the MCUA agreement. BGW experiences a lag time from the sample collection date to the return of analytical data from the lab. As soon as data are available, adjustments are made to the process to bring it in to compliance. As such, the effluent water quality exceeded daily maximum metals limits for Lead and Nickel during the month of May.

Lead exceeded the daily maximum limit of 0.6 mg/l the first week of the month that further resulted in a monthly average above the limit. Adjustments were made to the process that brought metals removal into compliance for lead by the second week.

Nickel exceeded the limit of 0.36 mg/l the first week of the month, which resulted in a 30-day average exceedance. After adjustments to the process, nickel concentrations dropped by more than half the second week and were in compliance by the third week.

No other parameters were exceeded during the operating month

Change were made the metals removal process by increasing pH into the metals removal clarifier and increasing dosages of coagulant and polymer to enhance precipitation. Adjustments made to the process successfully reduced the effluent metals concentration.

The demonstration project was successfully completed on May 17th. The wastewater treatment system has been shut off and the equipment dismantled. No wastewater flowed to the MCUA after May 17th.

MIDDLESEX COUNTY UTILITIES AUTHORITY (MUA)
 SELF-MONITORING REPORT (SMR)

PERMITTEE NAME / ADDRESS

NAME: BIOGENESIS SEDIMENT WASHING LLC

ADDRESS: ZALCROW'S MILL ROAD

KEASBEY, NEW JERSEY 08832

MCLA TDA NUMBER: 000006 DISCHARGE POINT: DBN001

MONITORING PERIOD: FROM 5/1/06 TO 5/31/06

PARAMETER	QUANTITY OR LOADING			QUALITY OF CONCENTRATION			UNITS	# OF VIOL.	FREQUENCY OF ANALYSIS	SAMPLE TYPE	
	AVERAGE	MAXIMUM	UNITS	MINIMUM	AVERAGE	MAXIMUM					
Flow	Sample Measurement	0.024	0.231					0	✓		
	Permit Requirement	0.300 30-DAY AVG.	DAILY MAX	MGD					CONTINUOUS	N/A	
Flow (Total)	Sample Measurement	0.757	6.094					0	✓		
	Permit Requirement	REPORT MONTHLY	30-DAY TOTAL TO DATE	MG					CONTINUOUS	N/A	
Flow (gpm)	Sample Measurement	17.0	160					0	✓		
	Permit Requirement	REPORT 30-DAY AVG.	DAILY MAX	GPM					CONTINUOUS	N/A	
pH (Grab)	Sample Measurement			7.6		8.0		0	✓	✓	
	Permit Requirement			5.0 MINIMUM		10.0 MAXIMUM	S.U.		DAILY	GRAB	
BOD, 5 DAY	Sample Measurement	20.56	104.0					0	✓	✓	
	Permit Requirement	REPORT 30-DAY AVG.	REPORT DAILY MAX	MG DAY					WEEKLY	GRAB	
COD	Sample Measurement	52.1	345					0	✓	✓	
	Permit Requirement	REPORT 30-DAY AVG.	REPORT DAILY MAX	MG DAY					WEEKLY	COMP.	
Total Suspended Solids (TSS)	Sample Measurement	0.92	4.95					0	✓	✓	
	Permit Requirement	REPORT 30-DAY AVG.	REPORT DAILY MAX	MG DAY					DAILY	COMP.	
I CERTIFY UNDER PENALTY OF LAW THAT I HAVE PERSONALLY EXAMINED AND AM FAMILIAR WITH THE INFORMATION SUBMITTED IN THIS DOCUMENT AND ALL ATTACHMENTS AND THAT, BASED ON MY KNOWLEDGE OF THESE INDIVIDUALS, I BELIEVE THE INFORMATION IS TRUE, ACCURATE AND COMPLETE. I AM AWARE THAT THERE ARE SIGNIFICANT PENALTIES FOR SUBMITTING FALSE INFORMATION, INCLUDING THE POSSIBILITY OF FINE AND IMPRISONMENT.										TELEPHONE	DATE
NAME / TITLE OF AUTHORIZED REPRESENTATIVE <i>Jana Sontag, Jr.</i> <i>St. Regisenv Muever</i>										732 738-3284	2006 06 28
SIGNATURE OF AUTHORIZED REPRESENTATIVE 										AREA CODE	YEAR
										NUMBER	MO
											DAY

ATTACH COMMENTS AND EXPLANATIONS OF ANY VIOLATIONS

INDIANIA COUNTY UTILITIES AUTHORITY (MCUA)
SELF-MONITORING REPORT (SMR)

PERMITTEE NAME / ADDRESS

NAME: BIOGENESIS SEDIMENT WASHING LLC

MCUA TDA NUMBER: 009.05 DISCHARGE POINT: DSN1001

ADDRESS: 75 CROWS MILL ROAD

MONITORING PERIOD: FROM May 1, 2006 TO May 31, 2006

KEASBEY, NEW JERSEY 08852

PARAMETER	QUANTITY OR LOADING			QUALITY OR CONCENTRATION			# OF VIOL.	FREQUENCY OF ANALYSIS	SAMPLE TYPE
	AVERAGE	MAXIMUM	UNITS	MINIMUM	AVERAGE	MAXIMUM			
Total Petroleum Hydrocarbons	Sample Measurement	1.26	MG DAY	*****	2.5	2.6	0	✓	✓
	Permit Requirement	REPORT DAILY MAX	MG DAY	*****	100 30-DAY AVG.	100 DAILY MAX		WEEKLY	GRAB
Cyanide (Total)	Sample Measurement	<0.004	MG DAY	*****	<0.006	<0.008	0	✓	✓
	Permit Requirement	REPORT DAILY MAX	MG DAY	*****	0.06 30-DAY AVG.	1.20 DAILY MAX		WEEKLY	GRAB
Arsenic	Sample Measurement	0.0009	MG DAY	*****	0.010	0.015	0	✓	✓
	Permit Requirement	REPORT DAILY MAX	MG DAY	*****	1.000 30-DAY AVG.	3.000 DAILY MAX		WEEKLY	COMP.
Cadmium	Sample Measurement	0.0029	MG DAY	*****	0.0059	0.0081	0	✓	✓
	Permit Requirement	REPORT DAILY MAX	MG DAY	*****	0.200 30-DAY AVG.	0.800 DAILY MAX		WEEKLY	COMP.
Chromium (Total)	Sample Measurement	<0.004	MG DAY	*****	0.004	0.005	0	✓	✓
	Permit Requirement	REPORT DAILY MAX	MG DAY	*****	0.300 30-DAY AVG.	0.200 DAILY MAX		WEEKLY	COMP.
Copper	Sample Measurement	<0.001	MG DAY	*****	<0.013	<0.017	0	✓	✓
	Permit Requirement	REPORT DAILY MAX	MG DAY	*****	0.200 30-DAY AVG.	1.100 DAILY MAX		WEEKLY	COMP.
Lead	Sample Measurement	0.061	MG DAY	*****	0.642	1.270	1	✓	✓
	Permit Requirement	REPORT DAILY MAX	MG DAY	*****	0.400 30-DAY AVG.	0.800 DAILY MAX		WEEKLY	COMP.
I CERTIFY UNDER PENALTY OF LAW THAT I HAVE PERSONALLY EXAMINED AND AM FAMILIAR WITH THE INFORMATION SUBMITTED IN THIS DOCUMENT AND ALL ATTACHMENTS AND THAT, BASED ON MY INQUIRY OF THOSE INDIVIDUALS IMMEDIATELY RESPONSIBLE FOR OBTAINING THE INFORMATION, I BELIEVE THE SUBMITTED INFORMATION IS TRUE, ACCURATE AND COMPLETE. I AM AWARE THAT THERE ARE SIGNIFICANT PENALTIES FOR SUBMITTING FALSE INFORMATION, INCLUDING THE POSSIBILITY OF FINE AND IMPRISONMENT.				TELEPHONE: 732 738-3284 AREA CODE: 732		DATE: 2006 06 28			
John Santay, Jr. Senior Program Manager				SIGNATURE OF AUTHORIZED REPRESENTATIVE: <i>John Santay</i>		NUMBER: 732 738-3284 YEAR: 2006 MO: 06 DAY: 28			
NAME / TITLE OF AUTHORIZED REPRESENTATIVE				TELEPHONE NUMBER		DATE			

MIDDLESEX COUNTY UTILITIES AUTHORITY (MUA)
SEWAGE MONITORING REPORT (SMR)

PERMITTEE NAME / ADDRESS

NAME: BIOGENESIS SEDIMENT WASHING LLC

ADDRESS: 75 CROWNS MILL ROAD

KEASBEE, NEW JERSEY 08852

MCUA TDA NUMBER: 00805

DISCHARGE POINT: DSN001

MONITORING PERIOD: FROM May 1, 2006 TO May 31, 2006

PARAMETER	QUANTITY OR LOADING			QUALITY OR CONCENTRATION			# OF VIB.	FREQUENCY OF ANALYSIS	SAMPLE TYPE
	AVERAGE	MAXIMUM	UNITS	MINIMUM	AVERAGE	MAXIMUM			
Mercury	Sample Measurement	<0.0001	<0.0002	*****	<0.0001	<0.002	0	✓	✓
	Permit Requirement	REPORT 30-DAY AVG.	REPORT DAILY MAX	*****	0.048 30-DAY AVG.	0.110 DAILY MAX		WEEKLY	COMP.
Nickel	Sample Measurement	0.033	0.283	*****	0.361	0.571	1	✓	✓
	Permit Requirement	REPORT 30-DAY AVG.	REPORT DAILY MAX	*****	0.170 30-DAY AVG.	0.280 DAILY MAX		WEEKLY	COMP.
Silver	Sample Measurement	<0.0002	<0.002	*****	<0.002	<0.005	0	✓	✓
	Permit Requirement	REPORT 30-DAY AVG.	REPORT DAILY MAX	*****	0.240 30-DAY AVG.	0.408 DAILY MAX		WEEKLY	COMP.
Zinc	Sample Measurement	<0.022	<0.182	*****	<0.240	<0.368	0	✓	✓
	Permit Requirement	REPORT 30-DAY AVG.	REPORT DAILY MAX	*****	0.880 30-DAY AVG.	2.200 DAILY MAX		WEEKLY	COMP.
Total Toxic Organics	Sample Measurement	<0.007	<0.038	*****	<0.076	<0.076	0	✓	✓
	Permit Requirement	REPORT 30-DAY AVG.	REPORT DAILY MAX	*****	REPORT 30-DAY AVG.	2.13 DAILY MAX		WEEKLY	COMP / GRAB
Volatile Organics	Sample Measurement	<0.010	<0.015	*****	<0.02	<0.03	0	✓	✓
	Permit Requirement	REPORT 30-DAY AVG.	REPORT DAILY MAX	*****	REPORT 30-DAY AVG.	REPORT DAILY MAX		WEEKLY	GRAB
Base/Neutrals	Sample Measurement	<0.001	<0.038	*****	<0.01	<0.076	0	✓	✓
	Permit Requirement	REPORT 30-DAY AVG.	REPORT DAILY MAX	*****	REPORT 30-DAY AVG.	REPORT DAILY MAX		WEEKLY	COMP.
I CERTIFY UNDER PENALTY OF LAW THAT I HAVE PERSONALLY EXAMINED AND AM FAMILIAR WITH THE INFORMATION SUBMITTED IN THIS DOCUMENT AND ALL ATTACHMENTS AND THAT, BASED ON MY INQUIRY OF THOSE INDIVIDUALS IMMEDIATELY RESPONSIBLE FOR OBTAINING THE INFORMATION, I BELIEVE THE SUBMITTED INFORMATION IS TRUE, ACCURATE AND COMPLETE. I AM AWARE THAT THERE ARE SIGNIFICANT PENALTIES FOR SUBMITTING FALSE INFORMATION, INCLUDING THE POSSIBILITY OF FINE AND IMPRISONMENT.				SIGNATURE OF AUTHORIZED REPRESENTATIVE 		TELEPHONE NUMBER 732 738-3284		DATE 3006 06 28	
NAME / TITLE OF AUTHORIZED REPRESENTATIVE John Santay, Jr. Senior Program Mgr.				AREA CODE 732		NUMBER 738-3284		YEAR 2006	
				MO 06		DAY 28			

ATTACH COMMENTS AND EXPLANATIONS OF ANY VIOLATIONS

FORM SMR-1.1 REVISION 02

PAGE 3 OF 4

APPENDIX E
RESULTS OF BENCH-SCALE TESTING OF THE
BIOGENESISSM SEDIMENT DECONTAMINATION
TECHNOLOGY FOR POLYAROMATIC HYDROCARBONS
IN SEDIMENT FROM THE LOWER PASSAIC RIVER

DEMONSTRATION TESTING AND
FULL-SCALE OPERATION OF THE
BIOGENESISSM SEDIMENT DECONTAMINATION
PROCESS

TABLE OF CONTENTS

TABLE OF CONTENTS	E-1
TABLE OF TABLES.....	E-2
TABLE OF FIGURES.....	E-3
INTRODUCTION.....	E-5
Run 1	E-7
Run 2	E-8
Run 3	E-9
Run 4	E-11
Run 5	E-12
Run 6	E-12
Run 7	E-13
Run 8	E-14
Run 9	E-15
Run 10.....	E-15
Run 11.....	E-17
Run 12, 13, 14, and 15	E-18
Run 16.....	E-19
Run 17.....	E-19
Run 18.....	E-21
Run 19.....	E-23
CONCLUSIONS	E-24

TABLE OF TABLES

Table E-1	Data Summary Bench-Scale Testing On Lower Passaic River Sediment Biogenesis Sediment Decontamination Process	E-27
Table E-2	Run 1 Total PAH Concentrations	E-8
Table E-3	Run 2 Total PAH Concentrations	E-9
Table E-4	Run 3 Total PAH Concentrations	E-11
Table E-5	Run 10 Total PAH Concentrations.....	E-17
Table E-6	Run 17 Percent Organic Results	E-20
Table E-7	Run 18 Total PAH Concentrations.....	E-21

TABLE OF FIGURES

Figure E-1	Lower Passaic River Bench Testing – Run 1	E-7
Figure E-2	Lower Passaic River Bench Testing – Run 2	E-8
Figure E-3	Lower Passaic River Bench Testing – Run 3	E-10
Figure E-4	Lower Passaic River Bench Testing – Run 4	E-11
Figure E-5	Lower Passaic River Bench Testing – Run 5	E-12
Figure E-6	Lower Passaic River Bench Testing – Run 6	E-12
Figure E-7	Lower Passaic River Bench Testing – Run 7	E-13
Figure E-8	Lower Passaic River Bench Testing – Run 8	E-14
Figure E-9	Lower Passaic River Bench Testing – Run 9	E-15
Figure E-10	Lower Passaic River Bench Testing – Run 10	E-16
Figure E-11	Lower Passaic River Bench Testing – Run 11	E-17
Figure E-12	Lower Passaic River Bench Testing – Run 12	E-18
Figure E-13	Lower Passaic River Bench Testing – Run 13	E-18
Figure E-14	Lower Passaic River Bench Testing – Run 14	E-18
Figure E-15	Lower Passaic River Bench Testing – Run 15	E-18
Figure E-16	Lower Passaic River Bench Testing – Run 16	E-19
Figure E-17	Lower Passaic River Bench Testing – Run 17	E-20
Figure E-18	Lower Passaic River Bench Testing – Run 18	E-22
Figure E-19	Lower Passaic River Bench Testing – Run 19	E-23

INTRODUCTION

The BioGenesisSM Sediment Decontamination Technology is a physical/chemical process that uses impact forces and chemical forces to strip contaminants from the surface of sediment particles and suspend them in a water phase where they can be separated from the sediment. The physical characteristics of the sediment particles (i.e., density, porosity, grain size, chemical structure, etc.) play a large role in the performance of the decontamination process. The nature of the contaminants also plays a role in the performance of the decontamination process. This includes the chemical and physical characteristics of the contaminants as well as the location of the contaminants within the sediment matrix.

During the full-scale demonstration project, it was observed that the concentrations of organic contaminants, specifically PAHs, in the processed sediment from the Lower Passaic River and Arthur Kill *decreased* with decreasing particle sizes. This was an unexpected result. Since sediment contaminants are adsorbed to the surface of inorganic sediment particles, and the surface area per volume increases exponentially as particle sizes get smaller, one would expect the concentrations of contaminants to *increase* with decreasing particle sizes. A second observation from the full-scale demonstration project was that debris removed in the secondary screen, prior to decontamination, showed the sediment contained a significant amount of organic detritus (plant and animal based fibrous material) and chemical analysis of the oversized organic detritus material showed that the fibers were highly saturated with PAHs.

Based on these observations, it was hypothesized that the majority of the organic contaminants in the sediment matrix were absorbed in the organic detritus (fibrous material) and not adsorbed to the sediment surface. When processed through the BioGenesisSM Sediment Decontamination Process, the efficiency of the collision impact forces to remove contaminants is reduced for contaminants absorbed in organic matter, which is porous, spongy, and less dense than sediment particles.

BioGenesis conducted a series of bench tests using dredged material from the Lower Passaic River to investigate the nature of PAHs in the sediment and refine the method for removal of the PAHs. A total of 19 test runs were conducted at the BioGenesis testing facility in Milwaukee, Wisconsin, from January through May 2008. The objectives of the testing were to 1) confirm or disprove the theory of the nature of PAHs in the sediment from the Lower Passaic River, and 2) to develop a separation step that could be added to or complement the BioGenesisSM Sediment Decontamination Technology which would reduce the concentrations of PAHs in the decontaminated sediment.

Iterative testing allowed the use of a variety of chemical formulations and facilitated the operation of various equipment configurations during processing. Samples were collected periodically during the test runs and analyzed for PAHs. The analytical results, summarized in Table E-1 at the end of this Appendix, showed that a micro-floatation technique using fine air bubbles (30 to 40 microns) can be added to the BioGenesisSM Sediment Decontamination Process prior to the Solid/Liquid Separation step to separate the PAH contaminated organic fibers from the decontaminated sediment particles. Samples of the recovered sediment particles showed concentrations of total PAHs ranging from 2 to 8 mg/kg.

The individual test runs are discussed in the following Subsections, and the results are summarized in the Conclusion Subsection.

Run 1

Run 1, illustrated in Figure E-1, was conducted on January 8 and 9, 2008. Hydrocyclones were used to physically separate light organic fibers and detritus from the sediment prior to decontamination. The preprocessor was used to disaggregate the sediment matrix prior to the hydrocyclones. In addition, the solids recovered following decontamination were dried in an oven at 100 degrees Celsius to evaluate if the moisture content has an impact on the PAH concentrations.

The total PAHs detected in the collected samples, summarized in Table E-2 below, indicated similar results as were observed during

the full-scale demonstration project. The fractions of the decontaminated sediment that had larger particle sizes had higher concentrations of PAHs and the fractions of decontaminated sediment with smaller particle sizes had lower concentrations of PAHs. The use of the hydrocyclones to remove organic fibers did not have a large enough impact on the PAH concentrations in the decontaminated sediment. Also,

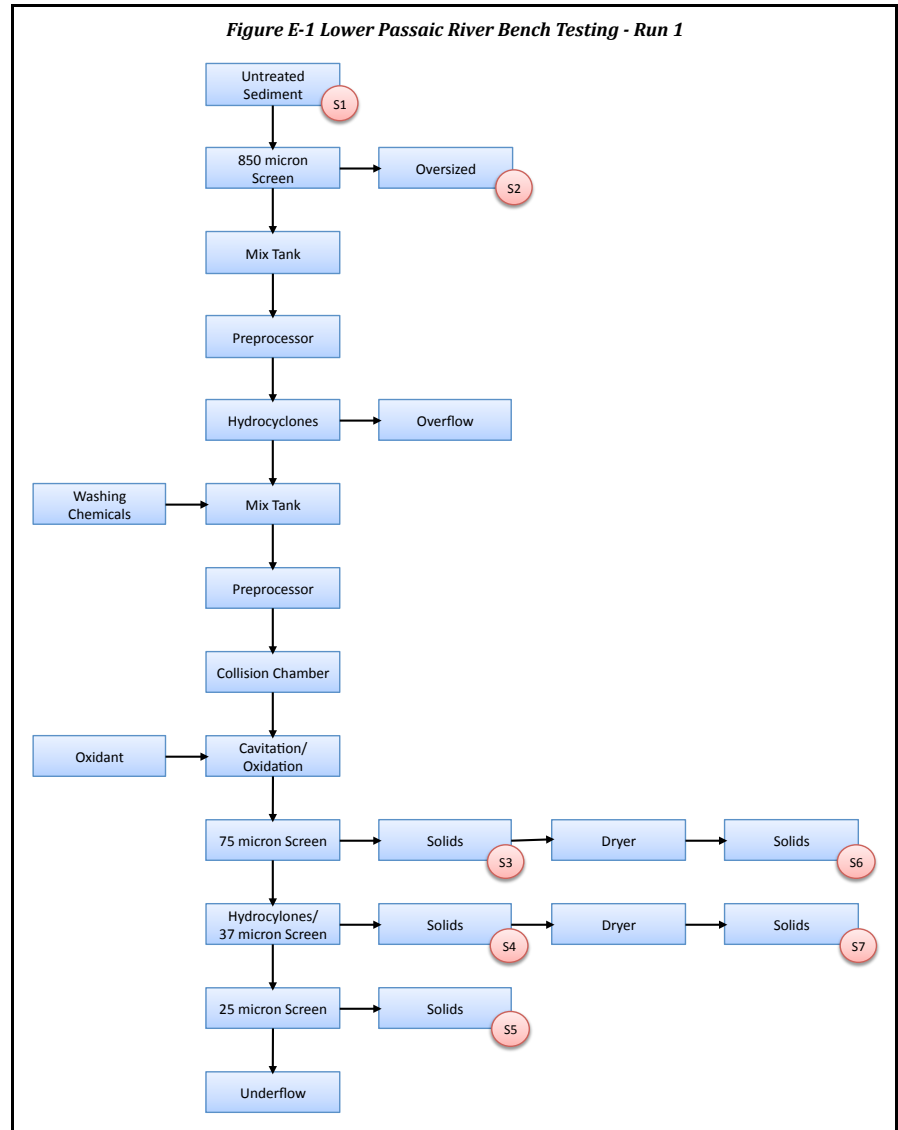

drying the samples prior to analysis reduced the concentrations of PAHs, probably due to volatilization of some of the PAHs.

Table E-2 Run 1 Total PAH Concentrations

Sample Location	Total PAHs (mg/kg)	Total PAHs after drying (mg/kg)
Untreated (S1)	19.610	-
Oversized (S2)	30.180	-
Treated Sediment > 75 microns (S3/S6)	150.080	48.285
Treated Sediment 37 - 75 microns (S4/S7)	37.810	19.130
Treated Sediment 25 - 37 microns (S5)	19.353	-

Run 2

Run 2, illustrated in Figure E-2, was conducted on January 15, 2008 to evaluate the changes in PAH concentrations following each processing step of the BioGenesisSM

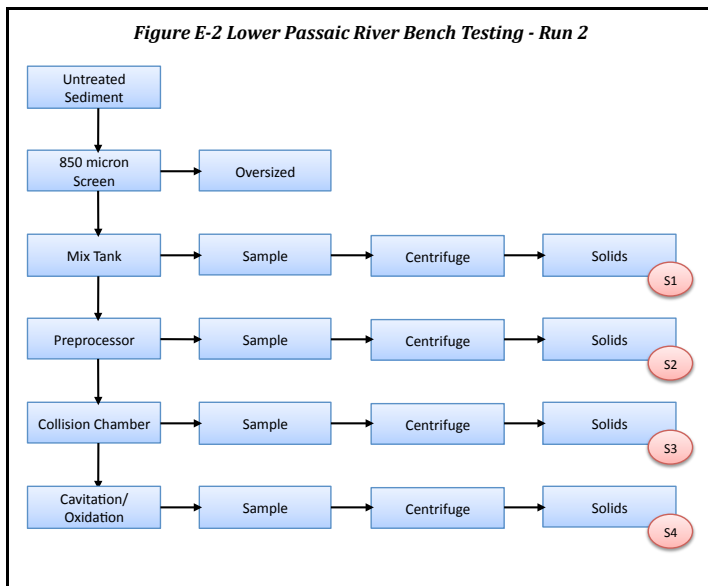

Sediment Decontamination Process. No washing chemicals were added during Run 2. Samples of the sediment slurry were collected following each main processing step and dewatered in a bench top centrifuge.

The concentration of total PAHs in the collected samples, summarized in Table E-3 below, increased following the collision chamber and decreased slightly following the cavitation/

oxidation unit. Since we do not feel PAHs are being generated through the process, these results seem to indicate that the Collision Chamber is liberating PAHs or making them available for extraction during chemical analysis.

Table E-3 Run 2 Total PAH Concentrations

Sample Location	Total PAHs (mg/kg)
Untreated (S1)	37.230
Following the Preprocessor (S2)	36.720
Following the Collision Chamber (S3)	70.190
Following Cavitation/Oxidation (S4)	57.480

Run 3

Run 3, illustrated in Figure E-3, was conducted on January 16, 2008. Several processing variations were tested during Run 3. The BioGenesis™ Preprocessor and hydrocyclones were used to physically separate light organic fibers and detritus from the sediment prior to decontamination. The washing chemicals were adjusted and a wetting agent was added to aid in the extraction of PAHs during processing. Finally, a portion of the sediment slurry was processed through the cavitation/oxidation process several additional times prior to solid/liquid separation to evaluate the effect of increased cavitation/oxidation processing.

The total PAHs detected in the samples collected, summarized in Table E-4 below, indicated similar results as were observed during the full-scale demonstration project and the initial bench test runs. The fractions of decontaminated sediment with larger particle sizes had higher concentrations of PAHs than the fractions with smaller particle sizes. In addition, the additional cavitation/oxidation had a negative impact on the PAH concentrations, i.e., the concentrations increased.

Figure E-3 Lower Passaic River Bench Testing - Run 3

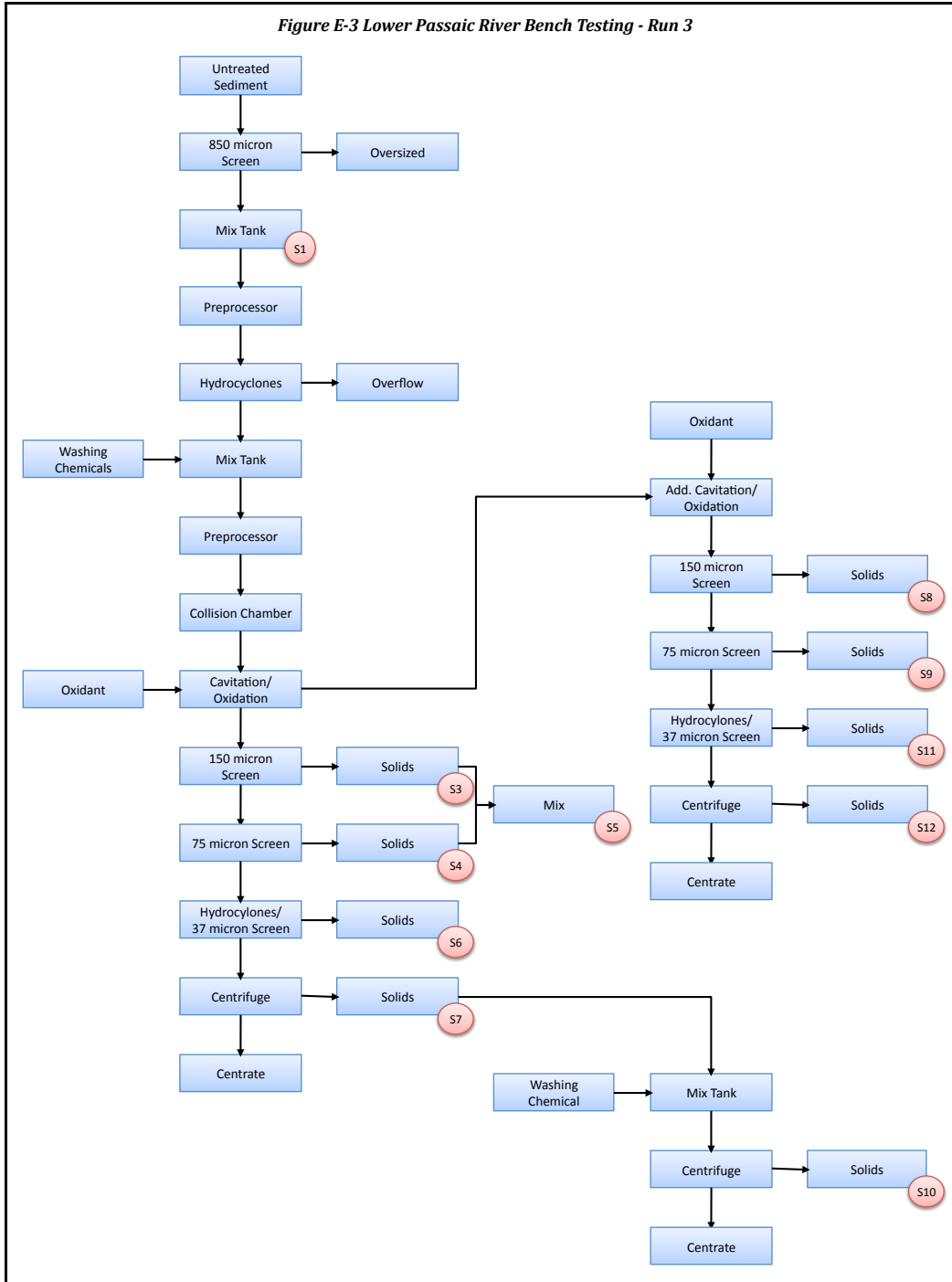

Table E-4 Run 3 Total PAH Concentrations

Sample Location	Total PAHs (mg/kg)	Total PAHs after additional Cavitation/Oxidation (mg/kg)
Untreated (S1)	26.220	-
Treated Sediment > 150 microns (S3/S8)	89.570	185.562
Treated Sediment 75 - 150 microns (S4/S9)	42.980	105.200
Treated Sediment 37 - 75 microns (S6/S11)	24.910	57.360
Treated Sediment Centrifuge Cake (S7/S12)	14.562	57.360

Run 4

Run 4, illustrated in Figure E-4, was conducted on February 5 and 6, 2008. The pH was lowered during Run 4 to evaluate the affect on PAH concentrations. In addition, additional processing of the decontaminated sediment (multiple wash cycles) was tested during Run 4.

There was no improvement in the final treated sediment in Run 4. The concentration of total PAHs in the untreated sediment was 26.21 mg/kg and the concentration of total PAHs in the decontaminated sediment was 38.65 mg/kg.

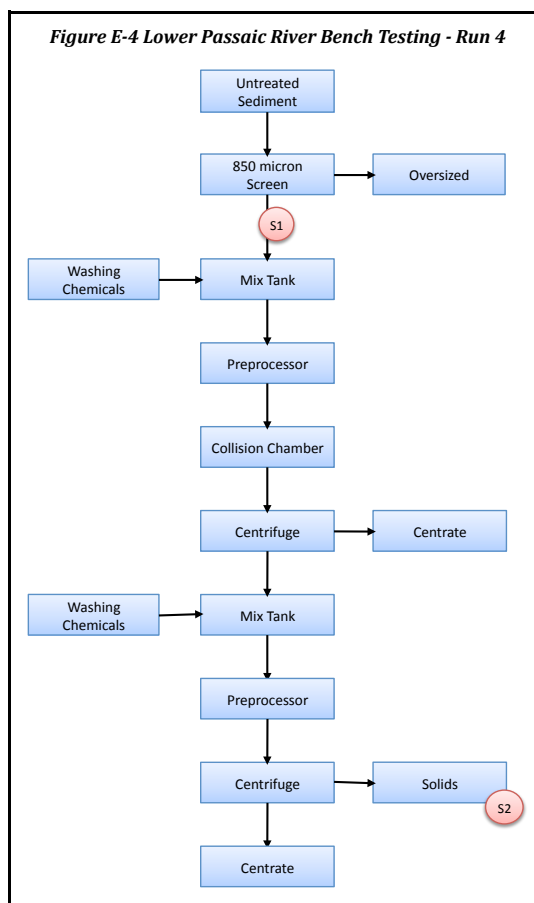

Run 5

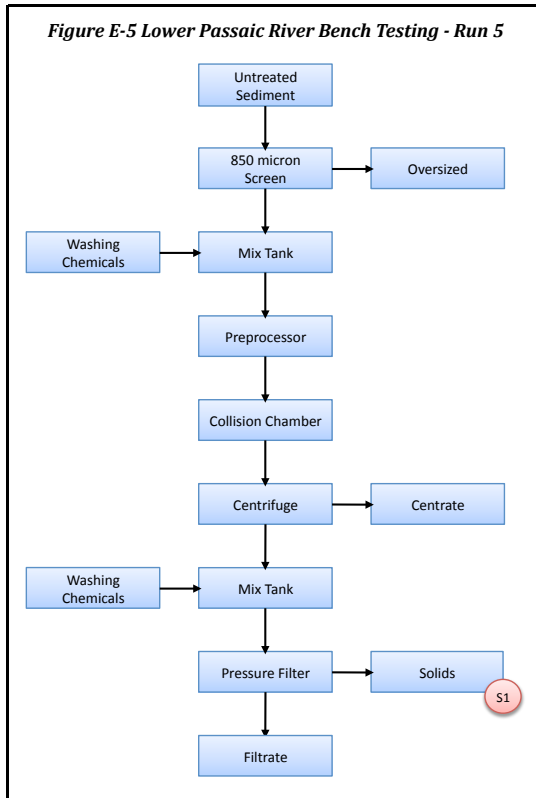

Run 5, illustrated in Figure E-5, was conducted on February 15 and 20, 2008. The pH was lowered and the water temperature was increased during Run 5 to evaluate the affect on PAH concentrations. In addition, additional processing of the decontaminated sediment (multiple wash cycles) was tested during Run 5. Finally, a wetting agent was used to aid in the extraction of PAHs.

There was a minimal improvement in the final treated sediment in Run 5. The concentration of total PAHs in the decontaminated sediment was 10.55 mg/kg.

Run 6

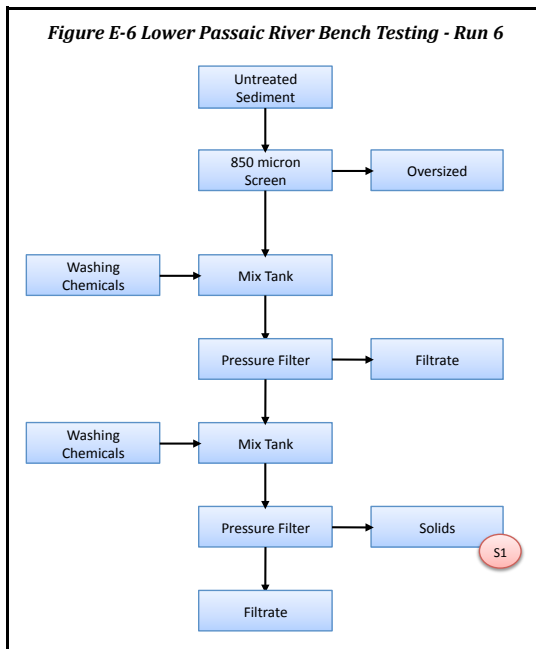

Run 6, illustrated in Figure E-6, was conducted on February 21 and 27, 2008 to further investigate the performance of the wetting agent to aid in the extraction of PAHs. No processing was performed during Run 6.

The concentration of total PAHs in the sediment after mixing and dewatering was 9.507 mg/kg. These results indicate the wetting agent may be effective in aiding in extraction of PAHs.

Run 7

Run 7, illustrated in Figure E-7, was conducted on February 28, 2008 to investigate the performance of the wetting agent to aid in the extraction of PAHs along with the BioGenesisSM Sediment Decontamination Technology. Samples of the decontaminated solids were collected with and without cavitation/oxidation.

The concentration of total PAHs in the sediment without cavitation/oxidation was 21.11 mg/kg and the concentration of total PAHs in the sediment with cavitation/oxidation was 32.38 mg/kg. This agrees with the previous observations where additional processing showed higher levels of PAHs.

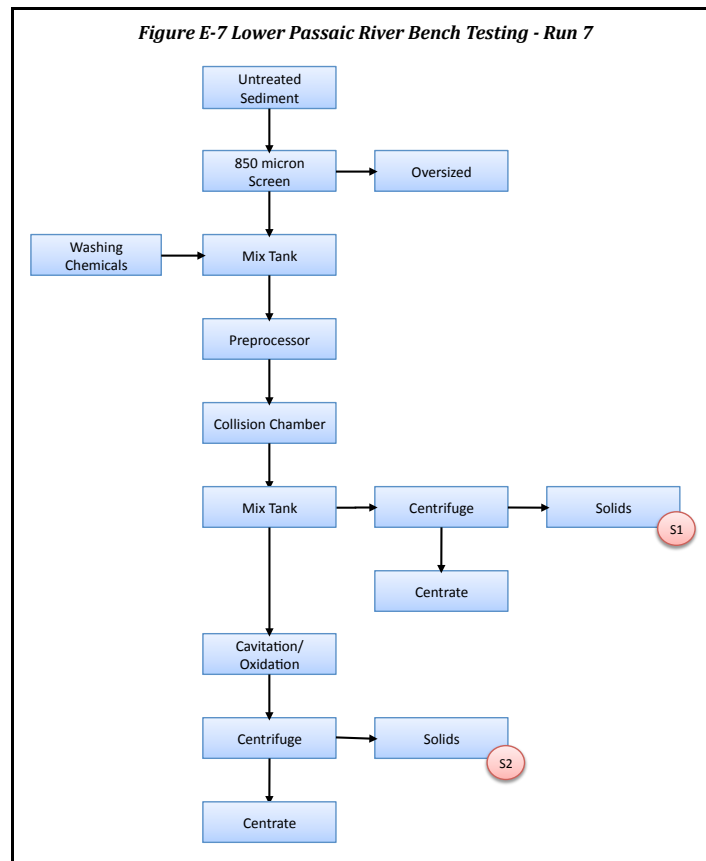

Run 8

Run 8, illustrated in Figure E-8, was conducted on February 28 and 29, 2008. The wetting agent was allowed to sit in the sediment overnight prior to processing. No improvement was observed with the concentration of total PAHs in the decontaminated sediment at 33.33 mg/kg.

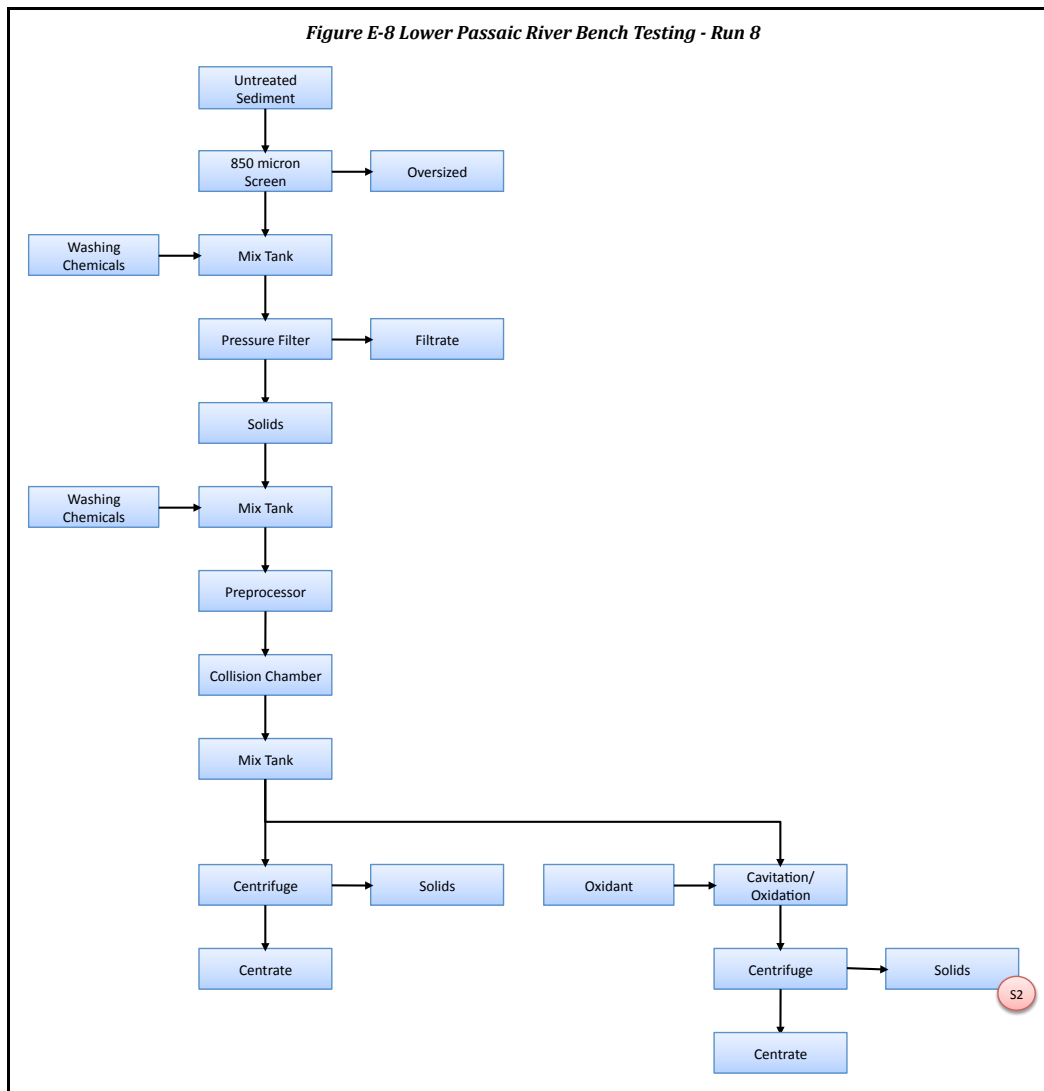

Run 9

Run 9, illustrated in Figure E-9, was conducted on February 26, 2009 to investigate if natural humus would break down into PAHs when processed through the BioGenesisSM Sediment Decontamination Process. Lignite was used as the natural humus material. Samples were collected of the screened, untreated lignite, and the concentration of total PAHs was 2.2 mg/kg. The lignite was dewatered after processing through the BioGenesisTM Pre-processor and the BioGenesisTM Collision Chamber and sampled. The dewatered lignite was then re-slurried and processed through the cavitation/oxidation unit, dewatered and sampled. The concentration of total PAHs in the dewatered sediment prior to and after cavitation/oxidation was 1.9 mg/kg. This indicates that lignite, a natural humus material, will not break down into PAHs when processed through the BioGenesisSM Sediment Decontamination Process.

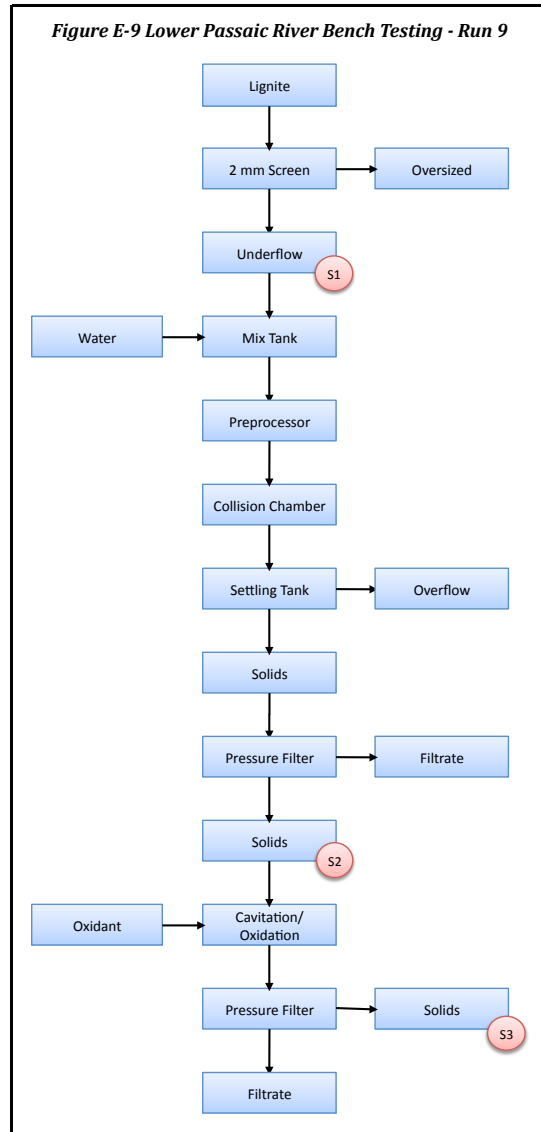

Run 10

Run 10, illustrated in Figure E-10, was conducted on March 17, 2008. A BioGenesis surfactant was added to the screened sediment and allowed to mix for approximately 1 hour. The sediment slurry was then processed through the BioGenesisTM Preprocessor and the solids were separated using a centrifuge. The

solids were treated with a wetting agent and centrifuged twice in an attempt to extract the organics (PAHs). The centrate from each solid/liquid separation step were mixed together and processed through the BioGenesis™ Cavitation/Oxidation unit. Samples of the centrate were collected prior to and after cavitation/oxidation.

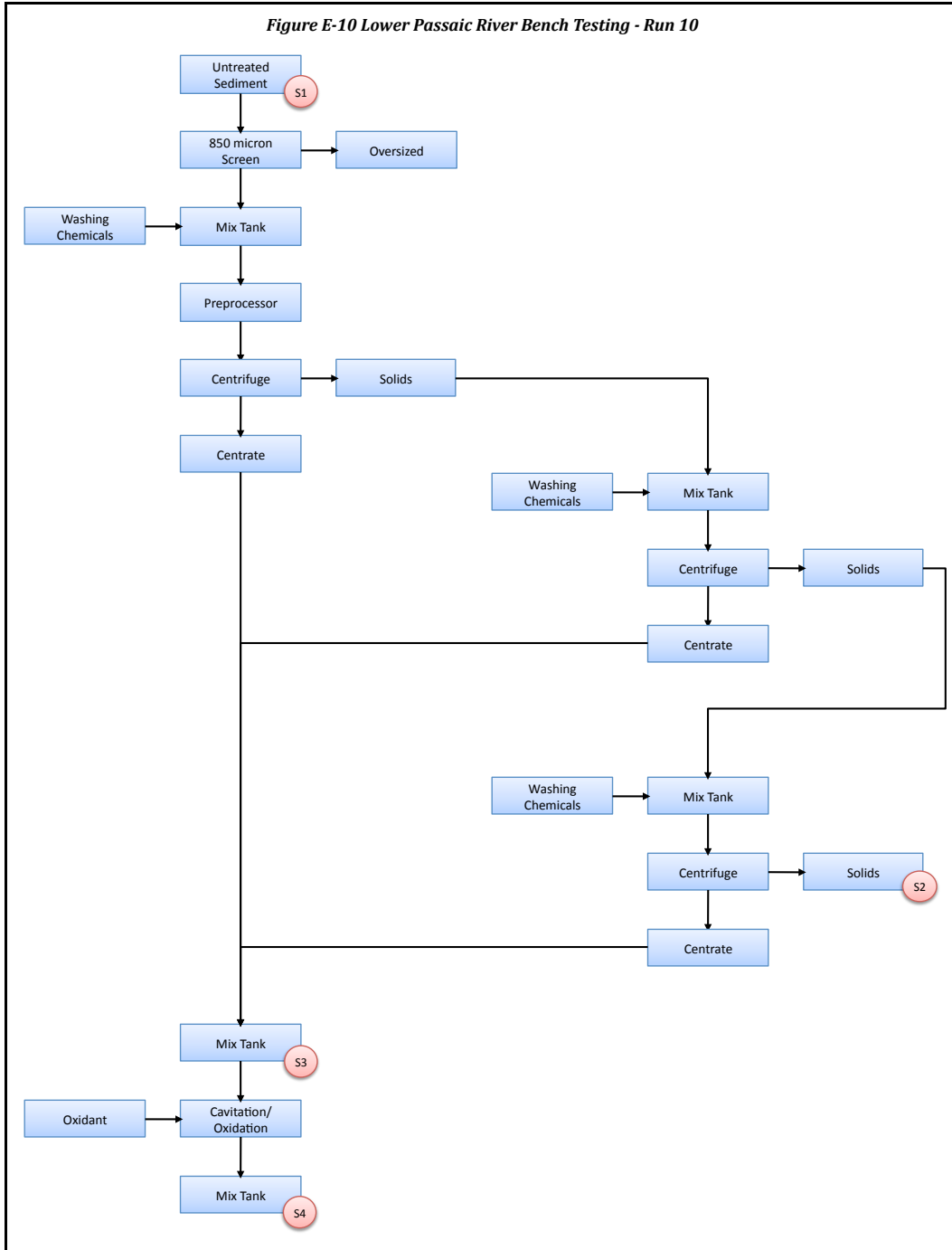

The concentration of total PAHs in the collected samples, summarized in Table E-5 below, did not change in the sediment solids. The concentration of total PAHs in the centrate more than doubled following treatment in cavitation/oxidation unit again pointing toward liberating PAHs through the BioGenesisSM Sediment Decontamination Process.

Table E-5 Run 10 Total PAH Concentrations

Sample Location	Total PAHs
Untreated Solids (S1)	21.51 mg/kg
Solids following treatment (S2)	21.78 mg/kg
Centrate (S3)	3.88 ug/L
Centrate following Cavitation/Oxidation (S4)	8.85 ug/L

Run 11

Run 11, illustrated in Figure E-11, was conducted on March 27, 2008. The untreated sediment was processed using the BioGenesisTM Preprocessor and BioGenesisTM Collision Chamber and the solids were centrifuged. Following solid/liquid separation, the decontaminated solids were rinsed with an organic wetting agent and centrifuged again. Samples were collected of the untreated sediment, the solids following the preprocessor, and the rinsed solids. The analytical results for PAHs for these samples showed a concentration of 24.94 mg/kg of total PAHs in the untreated sediment, 27.59 mg/kg of total

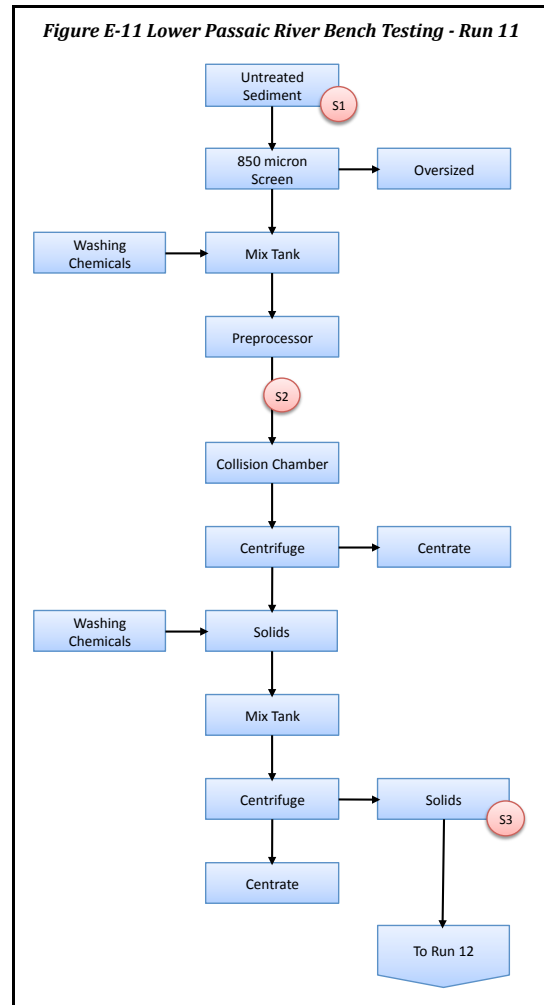

PAHs in the solids following the preprocessor, and 25.51 mg/kg of total PAHs in the rinsed sediment solids following processing. The solids from Run 11 were used in Run 12.

Runs 12, 13, 14, and 15

Runs 12, 13, 14, and 15, illustrated in Figures E-12, E-13, E-14, and E-15, respectively, were conducted from April 2 through 11, 2008 to further evaluate the effect

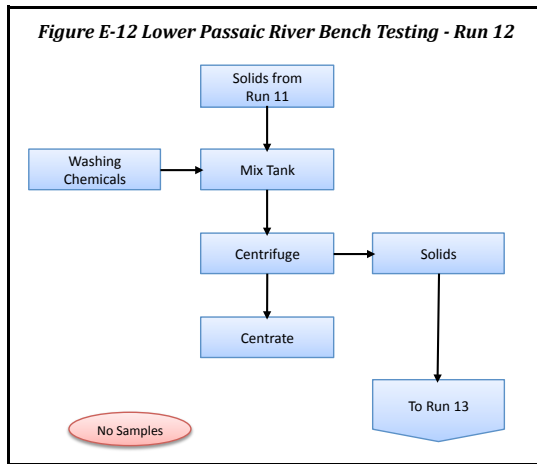

multiple processing steps on the concentrations of PAHs. The processed solids from Run 11 were used in Run 12; the processed solids from Run 12 were used for Run 13; etc. The processing steps were different for each test run and samples were collected of the processed solids. Chemical analysis was performed on the

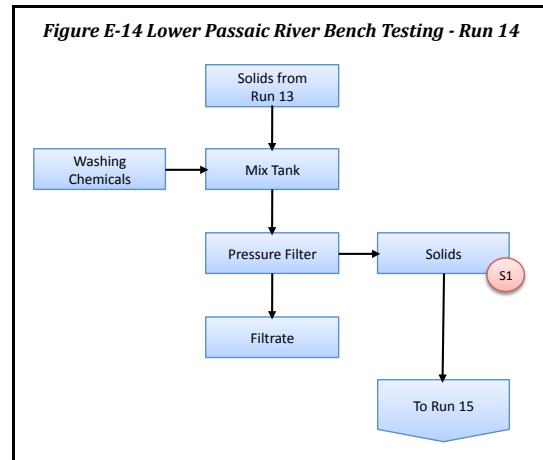
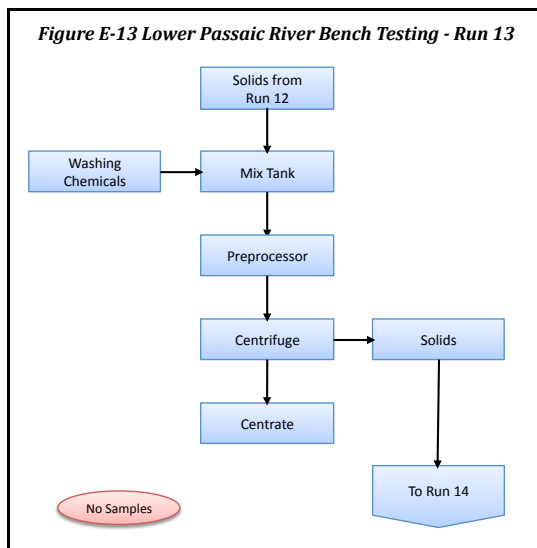

processed solids from Run 14 prior to the processed solids from the other runs, and when it was determined that the total PAH concentrations in the processed solids from Run 14 were 31.34 mg/kg, the re-

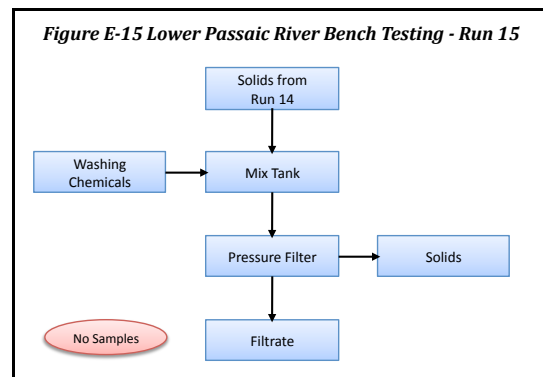

mainder of the samples were not analyzed. The PAH concentrations were not reduced through multiple processing cycles.

Run 16

Run 16, illustrated in Figure E-16, was conducted on April 14, 2008 and consisted of a series of jar tests where the naturally occurring organics were separated from the sediment particles using surfactants,

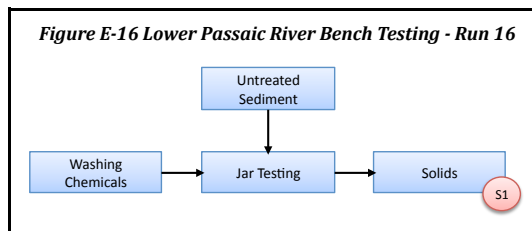

and wetting agents. The organic detritus was separated from the solid particles after rigorous mixing in a test tube. Visual observations during these jar tests indicated that the organic particles were very similar in density to the fine inorganic solid particles. Following a series of separation/floatation steps with the sediment in the jars, the settled solids were analyzed for PAHs. The concentration of total PAHs was 5.787 mg/kg indicating that a significant amount of the PAHs were contained in the light organic matter, and that this material could be separated from the sediment particles.

Run 17

Run 17, illustrated in Figure E-17, was conducted in three steps on April 24, 25, and May 1, 2008 to further investigate the separation of organic detritus from the sediment solids using density separation techniques (hydrocyclones). BioGenesis washing chemicals, wetting agents, and oxidants were added to the sediment, and it was processed using the BioGenesis™ Preprocessor. Solids were separated using hydrocyclones, and the underflow and overflow were dewatered using a bench-scale centrifuge. Samples of the recovered solids were tested for organic content.

The results of organics testing during Run 17 are summarized in Table E-6 below. The heaviest solid fraction (underflow of two hydrocyclone separation steps)

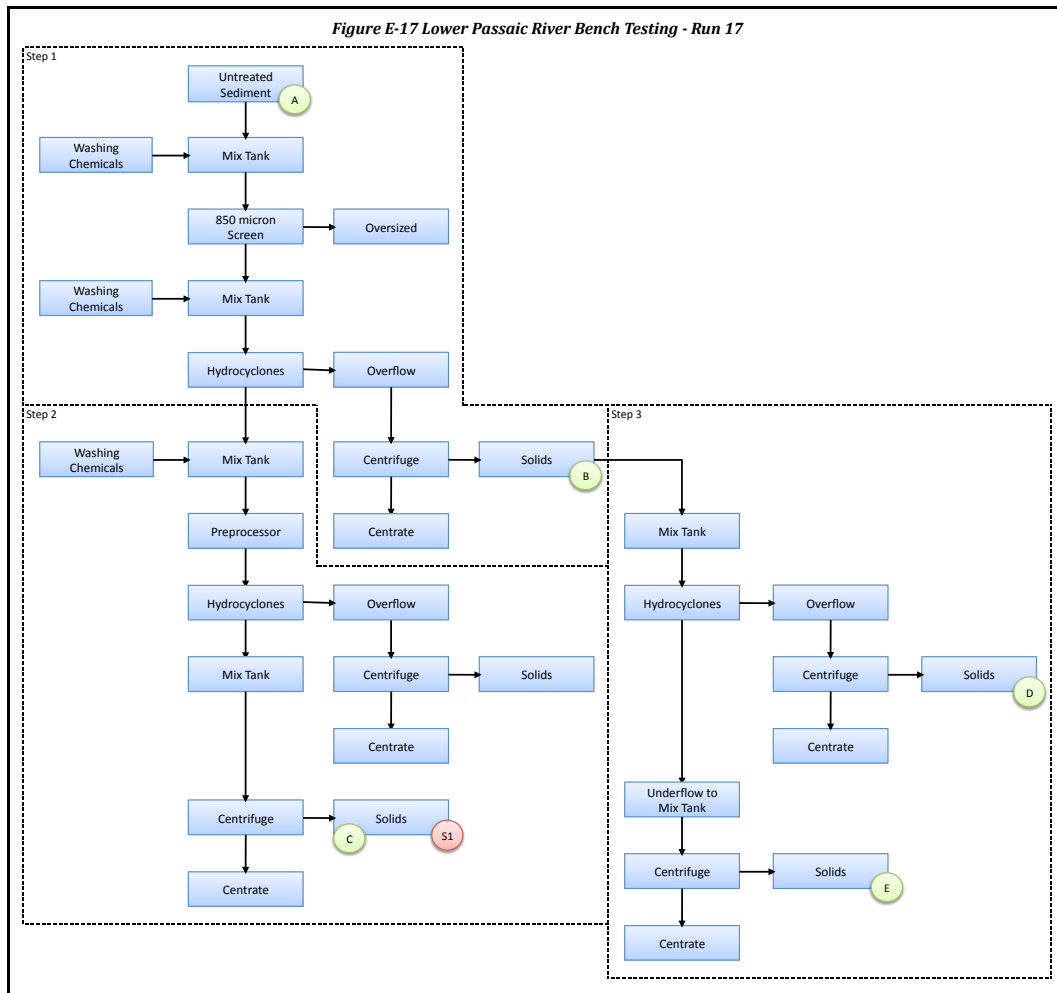

contained the lowest amount of organic material, however it was still above 3%. The concentration of total PAHs in this solid sample was 18.59 mg/kg.

Table E-6 Run 17 Percent Organic Results

Sample Location	Percent Organics
A - Untreated Sediment	11.2 %
B - Step 1 Hydrocyclone Overflow Solids	15.6 %
C - Step 2 Hydrocyclone Solids (S1)	3.1 %
D - Step 3 Hydrocyclone Overflow Solids	11.5 %
E - Step 3 Hydrocyclone Underflow Solids	15.8 %

Run 18

Run 18, illustrated in Figure E-18, was conducted on May 1, 2, and 5, 2008 to further investigate the effect of multiple processing steps on the PAH concentrations and to evaluate the use of micro-floatation as a separation step. The processing consisted of Preprocessing, Application of Collision Impact forces, Cavitation/Oxidation, and Solid/Liquid Separation. Hydrocyclones were not used to separate organic fibers from the sediment particles, as in previous tests; they were only used to concentrate solids on the 37 microns screen during the Solid/Liquid Separation step. Micro-floatation was used following the third processing cycle and a dramatic reduction in PAH concentrations was observed. Summarized in Table E-7 are the analytical results for total PAHs for samples collected during Run 18.

Table E-7 Run 18 Total PAH Concentrations

Sample Location	Total PAHs (mg/kg)
Screened, Untreated Solids (S1)	33.09
Combined Solids After One Treatment Cycle (S2)	23.29
Combined Solids After Two Treatment Cycles (S3)	19.32
Combined Solids After Three Treatment Cycles (S4)	17.067
> 37 micron Solids Following Micro-Floatation (S5)	1.993
Centrifuge Solids Following Micro-Floatation (S6)	8.454
Organic Detritus Following Micro-Floatation (S7)	108.72

Figure E-18 Lower Passaic River Bench Testing - Run 18

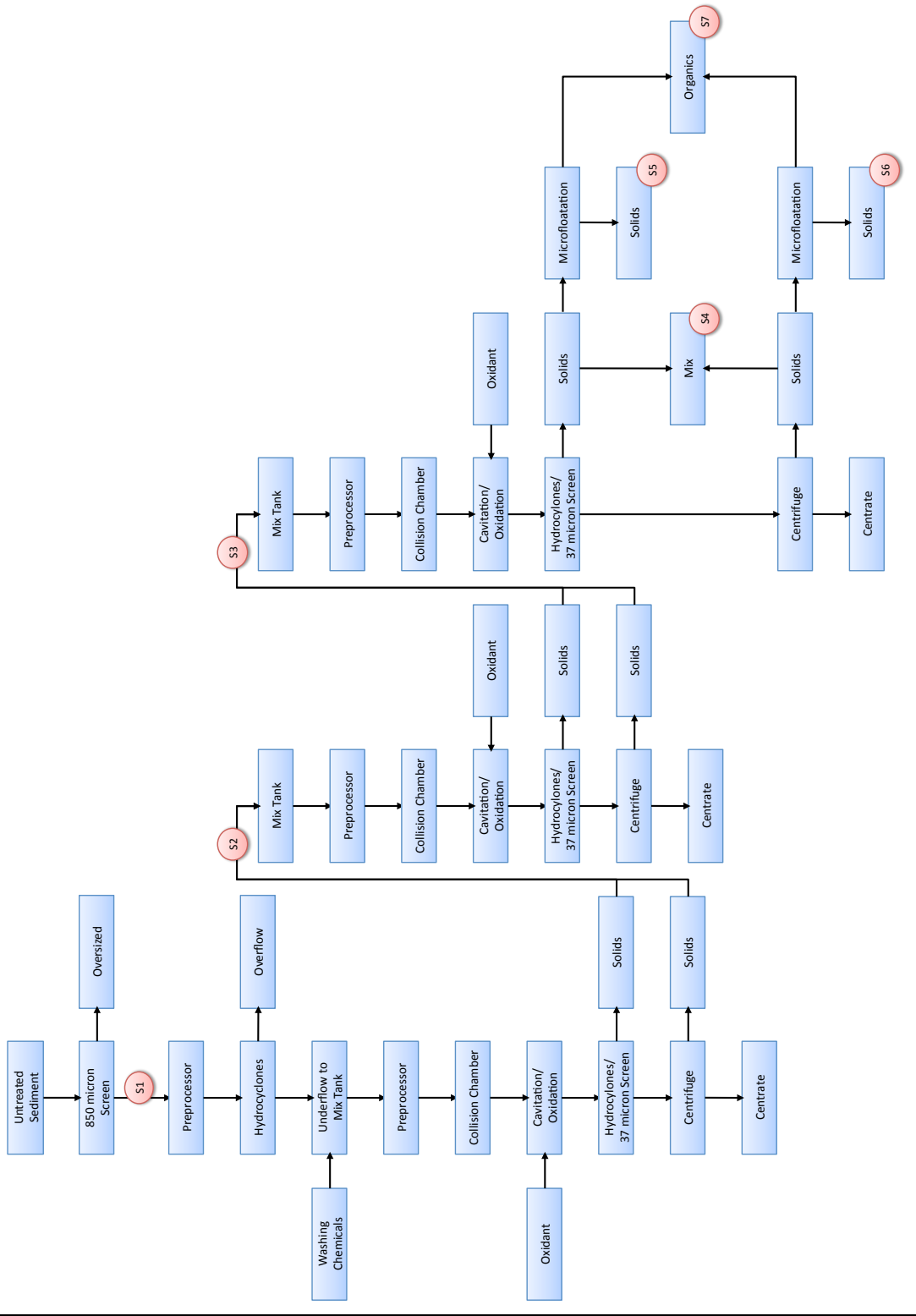

Run 19

Run 19, illustrated in Figure E-19, was conducted on May 5, 2008 to further investigate the use of micro-floatation as a separation step. During Run 19, only one processing step consisting of Separation of Large Organics with Hydrocyclones, Preprocessing, Application of Collision Impact forces, and Solid/Liquid Separation was tested. Oxidation was performed using oxidants in the mix tanks along with the washing chemicals. Hydrocyclones were used to thicken the sediment slurry and the underflow was centrifuged prior to micro-floatation. A sample of the decontaminated solids, following micro-floatation was collected for PAH analysis and the concentration of total PAHs was 4.186 mg/kg. The results indicate micro-floatation can be an effective step in the BioGenesisSM Sediment Decontamination Process for the removal of organic detritus containing organic contaminants.

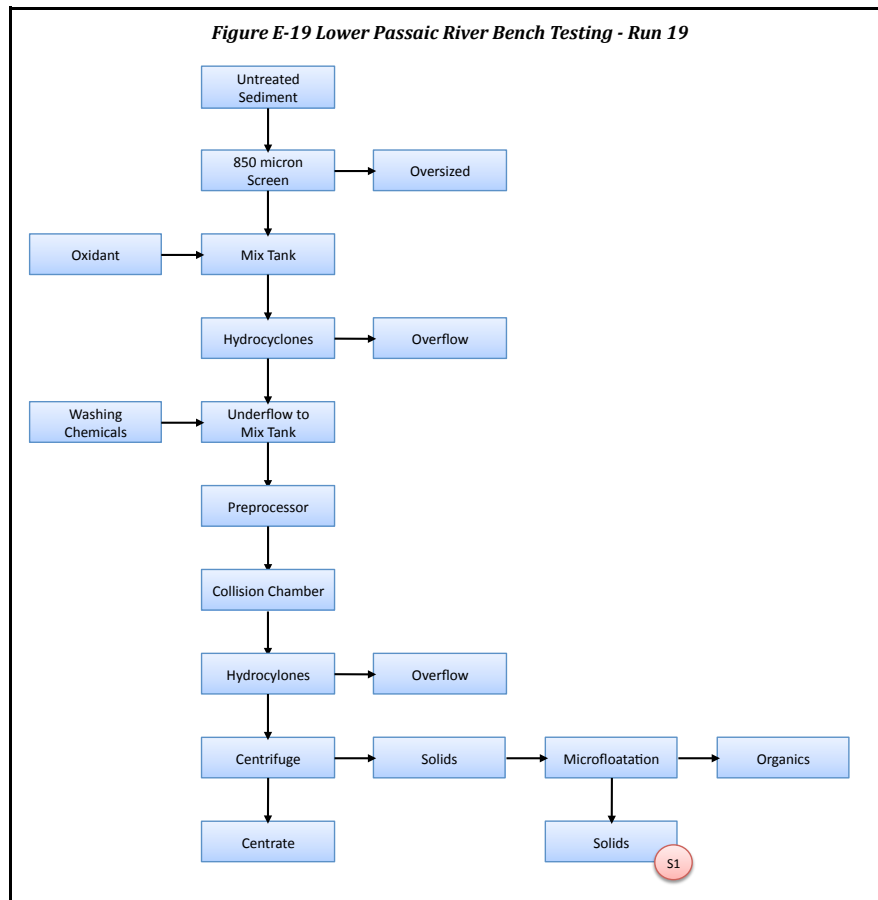

CONCLUSIONS

Based on observations made of the concentrations of organic contaminants in the treated sediment during the full-scale demonstration project, it was hypothesized that a significant portion of organic contaminants in the sediment matrix were absorbed in the organic detritus contained in the sediment matrix and not adsorbed to the surface of the sediment particles. When processed through the BioGenesisSM Sediment Decontamination Process, the ability of the collision impact forces to remove contaminants absorbed in organic material is minimal because organic matter is porous, spongy, and less dense than sediment particles and impact forces are reduced. The effect of processing the organic detritus (fibers) through the BioGenesisSM Sediment Decontamination Process would be that the fibers would be broken into smaller particles. This would have the undesired effect of making the organic contaminants absorbed in the organic detritus more easily extracted during chemical analysis.

During the bench testing in Milwaukee, several different processing steps for the separation of the organic material were evaluated. Separation using hydrocyclones did not provide adequate removal of the organic detritus and jar tests of the treated sediment showed that the organic matter settles at about the same rate as the sediment particles. This implies that the organic detritus has similar densities to the sediment particles and solid/liquid separation through hydrocyclones and centrifuges can't differentiate between the cleaned sediment particles and the PAH-laden organic fiber. The final bench experiments in Milwaukee showed that a micro-floatation technique using fine air bubbles (30 to 40 microns) would allow the PAH contaminated organic fibers to be floated and separated from solid particles with similar densities. Analytical results of the sample of floated organic fibers showed total PAH concentrations as high as 110 mg/kg, while samples of the recovered sediment particles showed concentrations of 2 to 8 mg/kg. Thus for sediment where there is a significant fraction of organic material in the sediment

and PAHs are a compound of concern, micro-floatation will be implemented as part of the solid/liquid separation step

Micro-floatation is routinely used in water and wastewater treatment for the removal of non-aqueous organic material. The BioGenesis™ Gondola utilizes micro-floatation to separate light organic material and non-aqueous organic material from the sediment slurry. The functionality of the BioGenesis™ Gondola was successfully tested during the 1999 Pilot Demonstration Project, but there was no significant amount of free-phase organic material or light organic solids to be removed from the sediment slurry during that project, which had significantly lower concentrations of organic contaminants and no discernable amount of organic detritus.

TABLE E-1

DATA SUMMARY
BENCH-SCALE TESTING ON LOWER PASSAIC RIVER SEDIMENT
 BIOGENESIS SEDIMENT DECONTAMINATION PROCESS
 (Page 1 of 7)

Run Number	Run 1	Run 1	Run 1	Run 1	Run 1	Run 1	Run 1	Run 2
Field Sample Identification	PR-010908-S1	PR-010908-S2	PR-010908-S3	PR-010908-S4	PR-010908-S5	PR-010908-S6	PR-010908-S7	PR-11508-R2-S1
Sample Date	1/9/08	1/9/08	1/9/08	1/9/08	1/9/08	1/9/08	1/9/08	1/15/08
Sample Time	15:00	15:05	15:10	15:15	15:20	15:25	15:30	14:45
Laboratory	TestAmerica	TestAmerica	TestAmerica	TestAmerica	TestAmerica	TestAmerica	TestAmerica	TestAmerica
General Soil Parameters								
Percent Solids (%)	28.9 %	31.3 %	43.9 %	66.9 %	71.3 %	99.0 %	99.9 %	29.4 %
PAHs by SW-846 8270c	ug/kg	ug/kg	ug/kg	ug/kg	ug/kg	ug/kg	ug/kg	ug/kg
Naphthalene	120 J	300 J	980	210 J	100 J	210	91 J	240
Acenaphthylene	260	1,000	2,100	560	240	420	260	700
Acenaphthene	120 J	230 J	1,100	210 J	93 J	ND (<170)	ND (<170)	260
Fluorene	180 J	320 J	1,400	310	150 J	95 J	69 J	360
Phenanthrene	1,000	1,100	11,000	2,100	980	970	510	2,100
Anthracene	430	930	3,800	810	380	790	390	850
Fluoranthene	3,300	4,100	26,000	6,400	3,300	6,100	2,400	7,400
Pyrene	2,700	4,100	21,000	5,000	2,500	4,100	1,300	4,800
Benzo(a)anthracene	1,500	3,200	13,000	3,200	1,400	4,000	1,200	2,700
Chrysene	2,100	3,500	15,000	3,900	2,000	6,300	2,400	3,500
Benzo(b)fluoranthene	2,300	3,100	15,000	4,300	2,400	8,100	3,200	4,400
Benzo(k)fluoranthene	850	1,300	6,300	1,500	840	2,600	1,000	1,500
Benzo(a)pyrene	1,800	3,200	13,000	3,500	1,700	3,000	1,200	3,200
Indeno (1,2,3-c,d)pyrene	1,200	1,500	8,200	2,300	1,300	4,500	2,000	2,500
Dibenzo(a,h)anthracene	350	500 J	2,500	710	370	1,400	610	520
Benzo(ghi)perylene	1,400	1,800	9,700	2,800	1,600	5,700	2,500	2,200
Total PAHs	19,610	30,180	150,080	37,810	19,353	48,285	19,130	37,230

J = Data are estimated due to associated quality control data.

B = Analyte detected in associated blank.

TABLE E-1

DATA SUMMARY
BENCH-SCALE TESTING ON LOWER PASSAIC RIVER SEDIMENT
BIOGENESIS SEDIMENT DECONTAMINATION PROCESS
 (Page 2 of 7)

Run Number	Run 2	Run 2	Run 2	Run 3	Run 3	Run 3	Run 3	Run 3
Field Sample Identification	PR-011508-R2-S2	PR-011508-R2-S3	PR-011508-R2-S4	PR-011608-R3-S1	PR-011608-R3-S3	PR-011608-R3-S4	PR-011608-R3-S5	PR-011608-R3-S6
Sample Date	1/15/08	1/15/08	1/15/08	1/16/08	1/16/08	1/16/08	1/16/08	1/16/08
Sample Time	15:00	15:30	15:55	8:15	11:30	11:40	12:15	13:45
Laboratory	TestAmerica	TestAmerica	TestAmerica	TestAmerica	TestAmerica	TestAmerica	TestAmerica	TestAmerica
General Soil Parameters								
Percent Solids (%)	43.2 %	29.2 %	41.4 %	22.8 %	39.7 %	70.4 %	64.3 %	66.5 %
PAHs by SW-846 8270c	ug/kg	ug/kg	ug/kg	ug/kg	ug/kg	ug/kg	ug/kg	ug/kg
Naphthalene	230	410	380	150	790	210	300	140
Acenaphthylene	730	1,300	1,000	480	1,100	320	440	160
Acenaphthene	260	470	400	190	510	ND (<48)	ND (<52)	ND (<50)
Fluorene	340	580	480	220	640	200	270	100
Phenanthrene	2,200	4,100	3,500	1,600	7,900	3,000	4,100	1,400
Anthracene	840	1,500	1,300	550	2,500	850	1,200	430
Fluoranthene	7,600	14,000	12,000	5,400	10,000	5,100	6,400	5,600
Pyrene	4,700	8,900	6,700	3,300	12,000	5,500	6,800	2,900
Benzo(a)anthracene	3,000	5,800	4,800	2,100	9,200	4,200	5,400	2,000
Chrysene	3,700	7,500	6,100	2,800	11,000	5,200	6,300	2,600
Benzo(b)fluoranthene	4,500	9,600	8,500	3,800	14,000	7,500	10,000	4,000
Benzo(k)fluoranthene	1,600	3,300	3,000	1,200	5,000	2,800	3,700	1,500
Benzo(a)pyrene	3,300	6,900	5,500	2,400	9,600	4,800	6,200	2,300
Indeno (1,2,3-c,d)pyrene	1,800	2,900	1,900	1,000	2,600	1,600	1,800	870
Dibenzo(a,h)anthracene	420	630	420	220	630	400	450	190
Benzo(ghi)perylene	1,500	2,300	1,500	810	2,100	1,300	1,500	720
Total PAHs	36,720	70,190	57,480	26,220	89,570	42,980	54,860	24,910

J = Data are estimated due to associated quality control data.

B = Analyte detected in associated blank.

TABLE E-1

DATA SUMMARY
BENCH-SCALE TESTING ON LOWER PASSAIC RIVER SEDIMENT
BIOGENESIS SEDIMENT DECONTAMINATION PROCESS
 (Page 3 of 7)

Run Number	Run 3	Run 3	Run 3	Run 3	Run 3	Run 3	Run 4	Run 4
Field Sample Identification	PR-011608-R3-S7	PR-011608-R3-S8	PR-011608-R3-S9	PR-011608-R3-S10	PR-011608-R3-S11	PR-011608-R3-S12	PR-020508-R4-S1	PR-020608-R4-S2
Sample Date	1/16/08	1/16/08	1/16/08	1/16/08	1/16/08	1/16/08	2/5/08	2/6/08
Sample Time	14:55	15:15	15:30	15:35	15:40	15:45	11:30	11:00
Laboratory	TestAmerica	TestAmerica	TestAmerica	TestAmerica	TestAmerica	TestAmerica	TestAmerica	TestAmerica
General Soil Parameters								
Percent Solids (%)	61.8 %	28.9 %	36.5 %	65.6 %	62.8 %	51.7 %	36.5 %	36.6 %
PAHs by SW-846 8270c	ug/kg	ug/kg	ug/kg	ug/kg	ug/kg	ug/kg	ug/kg	ug/kg
Naphthalene	89	1,400	640	84	310	200	190	280
Acenaphthylene	200	2,200	550	120	490	280	460	760
Acenaphthene	83	ND (<120)	ND (<92)	ND (<51)	230	ND (<65)	160 J	230
Fluorene	130	1,400	490	74	240	140	240	ND (<230)
Phenanthrene	820	20,000	8,600	750	3,800	1,600	1,500	2,200
Anthracene	290	6,100	2,100	250	1,100	510	620	910
Fluoranthene	3,200	29,000	13,000	3,100	7,000	6,500	4,800	6,900
Pyrene	1,700	23,000	16,000	1,800	8,600	4,700	3,600	4,900
Benzo(a)anthracene	1,100	20,000	10,000	990	5,200	2,200	2,100	3,200
Chrysene	1,500	22,000	12,000	1,400	6,400	2,900	2,600	3,900
Benzo(b)fluoranthene	2,300	14,000	18,000	2,100	10,000	4,600	3,300	4,500
Benzo(k)fluoranthene	810	13,000	7,100	890	3,900	1,700	880	1,600
Benzo(a)pyrene	1,300	22,000	10,000	1,200	6,000	2,500	2,200	3,300
Indeno (1,2,3-c,d)pyrene	520	5,400	3,300	470	2,000	1,000	1,500	2,500
Dibenzo(a,h)anthracene	110	1,400	860	110	490	230	360	670
Benzo(ghi)perylene	410	4,300	2,700	400	1,600	830	1,700	2,800
Total PAHs	14,562	185,200	105,340	13,738	57,360	29,890	26,210	38,650

J = Data are estimated due to associated quality control data.

B = Analyte detected in associated blank.

TABLE E-1

DATA SUMMARY
BENCH-SCALE TESTING ON LOWER PASSAIC RIVER SEDIMENT
BIOGENESIS SEDIMENT DECONTAMINATION PROCESS
 (Page 4 of 7)

Run Number	Run 5	Run 5	Run 6	Run 7	Run 7	Run 8	Run 9	Run 9
Field Sample Identification	PR-021508-R5-S1	PR-021508-R5-S1	PR-022708-R6-S1	PR-022808-R7-S1	PR-022808-R7-S2	PR-022908-R8-S2	PR-022608-R9-S1	PR-022608-R9-S2
Sample Date	2/20/08	2/20/08	2/27/08	2/28/08	2/28/08	2/29/08	2/26/08	2/26/08
Sample Time	13:10	13:10	12:50	12:30	13:30	13:30	9:00	14:00
Laboratory	TestAmerica	Veritech Lab	TestAmerica	TestAmerica	TestAmerica	TestAmerica	TestAmerica	TestAmerica
General Soil Parameters								
Percent Solids (%)	60.0 %	67.0 %	60.6 %	58.9 %	57.5 %	53.4 %	87.0 %	65.3 %
PAHs by SW-846 8270c	ug/kg	ug/kg	ug/kg	ug/kg	ug/kg	ug/kg	ug/kg	ug/kg
Naphthalene	81 J	ND (<1,000)	65 J	170	210	190	28 J	130
Acenaphthylene	150	210 J	130	420	660	600	ND (< 77)	16 J
Acenaphthene	60 J	140 J	57 J	120	170	180	ND (< 77)	13 J
Fluorene	82 J	190 J	75 J	200	220	210	ND (< 77)	21 J
Phenanthrene	610	1,600	550	1,500	1,500	1,800	200	190
Anthracene	250	360 J	210	600	600	650	42 J	34
Fluoranthene	1,800	3,300	1,800	5,300	4,900	5,300	710	640
Pyrene	1,700	3,500	1,300	1,700	7,000	6,000	310	230
Benzo(a)anthracene	920	1,600	750	1,800	2,400	2,700	130	110
Chrysene	1,000	2,100	950	2,100	3,100	3,500	370	280
Benzo(b)fluoranthene	1,200	2,900	1,100	3,000	4,400	4,100	410	270
Benzo(k)fluoranthene	500	900 J	480	ND (< 28)	1,400	2,000	ND (< 77)	(ND <26)
Benzo(a)pyrene	820	2,000	780	1,800	2,900	3,200	ND (< 77)	(ND <26)
Indeno (1,2,3-c,d)pyrene	520	1,200	470	1,300	1,400	1,500	ND (< 77)	(ND <26)
Dibenzo(a,h)anthracene	210	330 J	180	ND (< 28)	220	200	ND (< 77)	(ND <26)
Benzo(ghi)perylene	630	1,300	610	1,100	1,300	1,200	ND (< 77)	(ND <26)
Total PAHs	10,533	21,630	9,507	21,110	32,380	33,330	2,200	1,934

J = Data are estimated due to associated quality control data.

B = Analyte detected in associated blank.

TABLE E-1

DATA SUMMARY
BENCH-SCALE TESTING ON LOWER PASSAIC RIVER SEDIMENT
 BIOGENESIS SEDIMENT DECONTAMINATION PROCESS
 (Page 5 of 7)

Run Number	Run 9	Run 10	Run 10	Run 10	Run 10	Run 11	Run 11	Run 11
Field Sample Identification	PR-030608-R9-S3	PR-031708-R10-S1	PR-031708-R10-S2	PR-031708-R10-S3	PR-031708-R10-S4	PR-032708-R11-S1	PR-032708-R11-S2 (solid fraction)	PR-032708-R11-S3
Sample Date	3/6/08	3/17/08	3/17/08	3/17/08	3/17/08	3/27/08	3/27/08	3/27/08
Sample Time	13:25	9:15	14:50	14:15	14:25	7:45	10:10	13:00
Laboratory	TestAmerica	TestAmerica	TestAmerica	TestAmerica	TestAmerica	TestAmerica	TestAmerica	TestAmerica
General Soil Parameters								
Percent Solids (%)	57.6 %	35.5 %	69.0 %	-	-	40.9 %	45.6 %	63.8 %
PAHs by SW-846 8270c	ug/kg	ug/kg	ug/kg	ug/L	ug/L	ug/kg	ug/kg	ug/L
Naphthalene	120	140	120	0.29 J	0.34 J	110 J	150 J	160 J
Acenaphthylene	14 J	270	310	ND (<0.99)	ND (<1.1)	410	440	340
Acenaphthene	8.1 J	140	120	ND (<0.99)	ND (<1.1)	110 J	170 J	130 J
Fluorene	21 J	150	200	ND (<0.99)	ND (<1.1)	720	690	520
Phenanthrene	190	1,300	1,300	0.47 JB	0.79 JB	1,100	1,300	1,300 J
Anthracene	32	490	470	ND (<0.99)	ND (<1.1)	470	620	460
Fluoranthene	600	3,100	3,000	0.84 J	1.60	3,700	4,300	3,900
Pyrene	290	3,400	3,100	0.69 J	1.40	3,500	5,300	4,200
Benzo(a)anthracene	120	2,300	2,400	0.36 JB	0.76 JB	1,800	2,100	2,000 J
Chrysene	290	2,100	2,200	0.36 JB	0.89 JB	2,100	2,600	2,400 J
Benzo(b)fluoranthene	230	3,200	3,300	0.37 JB	0.95 JB	3,100	3,400	2,800 J
Benzo(k)fluoranthene	ND (< 29)	ND (<94)	ND (<48)	ND (<0.99)	0.38 JB	1,900	ND (<370)	1,500 J
Benzo(a)pyrene	ND (< 29)	1,900	1,900	0.25 J	0.67 J	2,200	2,500	2,300 J
Indeno (1,2,3-c,d)pyrene	ND (< 29)	1,200	1,300	ND (<0.99)	0.43 J	1,500	1,700	1,400 J
Dibenzo(a,h)anthracene	ND (< 29)	320	460	ND (<0.99)	ND (<1.1)	720	720	600
Benzo(ghi)perylene	ND (< 29)	1,500	1,600	0.25 J	0.64 J	1,500	1,600	1,500 J
Total PAHs	1,915	21,510	21,780	3.88	8.85	24,940	27,590	25,510

J = Data are estimated due to associated quality control data.

B = Analyte detected in associated blank.

TABLE E-1

DATA SUMMARY
BENCH-SCALE TESTING ON LOWER PASSAIC RIVER SEDIMENT
BIOGENESIS SEDIMENT DECONTAMINATION PROCESS
 (Page 6 of 7)

Run Number	Run 14	Run 16	Run 17	Run 18	Run 18	Run 18	Run 18	Run 18
Field Sample Identification	PR-041008-R14-S1	PR-041808-R16-S1	PR-042508-R17-S1	PR-50108-R18-S1	PR-50208-R18-S2	PR-50508-R18-S3	PR-50508-R18-S4	PR-50908-R18-S5
Sample Date	4/10/08	4/18/08	4/18/08	5/1/08	5/2/08	5/5/08	5/5/08	5/9/08
Sample Time	15:00	14:15	13:05	8:00	14:00	7:00	10:15	11:30
Laboratory	TestAmerica	TestAmerica	TestAmerica	TestAmerica	TestAmerica	TestAmerica	TestAmerica	TestAmerica
General Soil Parameters								
Percent Solids (%)	82.4 %	79.6 %	77.2 %	42.3 %	69.0 %	76.0 %	78.6 %	80.9 %
PAHs by SW-846 8270c	ug/kg	ug/kg	ug/kg	ug/kg	ug/kg	ug/kg	ug/kg	ug/kg
Naphthalene	480	110	81	220	200	160	140	7.8 J
Acenaphthylene	760	71	100	570	430	360	190	15 J
Acenaphthene	ND (< 410)	48	70	200	140	120	87	7.4 J
Fluorene	ND (< 410)	64	83	270	210	170	120	11 J
Phenanthrene	2,100	480	1,100	2,000	1,500	1,400	1,200	120
Anthracene	820	160	250	740	500	420	320	27
Fluoranthene	5,600	1,500	3,400	7,400	4,800 D	3,800 D	4,100	470
Pyrene	4,000	ND (< 21)	2,400	4,000	2,600	2,100	1,800	250
Benzo(a)anthracene	2,600	520	1,500	3,200	2,200	2,100	1,600	180
Chrysene	3,300	770	2,100	3,200	2,500	2,200	1,900	20
Benzo(b)fluoranthene	3,900	810	3,000	4,600	3,300	2,700	2,600	330
Benzo(k)fluoranthene	1,000	380	ND (< 22)	ND (< 39)	ND (< 24)	ND (< 22)	ND (< 21)	ND (< 21)
Benzo(a)pyrene	2,800	510	1,700	3,200	2,800	2,200	1,600	190
Indeno (1,2,3-c,d)pyrene	1,900	ND (< 21)	1,200	1,500	920	700	630	150
Dibenzo(a,h)anthracene	ND (< 410)	24	210	390	220	170	180	45
Benzo(ghi)perylene	2,100	340	1,400	1,600	970	720	600	170
Total PAHs	31,360	5,787	18,594	33,090	23,290	19,320	17,067	1,993

J = Data are estimated due to associated quality control data.

B = Analyte detected in associated blank.

TABLE E-1

DATA SUMMARY
BENCH-SCALE TESTING ON LOWER PASSAIC RIVER SEDIMENT
BIOGENESIS SEDIMENT DECONTAMINATION PROCESS
 (Page 7 of 7)

Run Number	Run 18	Run 18	Run 19
Field Sample Identification	PR-50908-R18-S6	PR-50908-R18-S7	PR-50908-R19-S1
Sample Date	5/9/08	5/9/08	5/9/08
Sample Time	12:35	12:50	13:15
Laboratory	TestAmerica	TestAmerica	TestAmerica
General Soil Parameters			
Percent Solids (%)	75.8 %	40.2 %	77.8 %
PAHs by SW-846 8270c	ug/kg	ug/kg	ug/kg
Naphthalene	70	1,100	20 J
Acenaphthylene	130	2,300	46
Acenaphthene	36	1,100	13 J
Fluorene	58	1,400	21 J
Phenanthrene	480	12,000	230
Anthracene	150	3,300	58
Fluoranthene	1,900	24,000	1,000
Pyrene	790	13,000	430
Benzo(a)anthracene	680	31,000	380
Chrysene	930	ND (< 83)	420
Benzo(b)fluoranthene	1,600	280	800
Benzo(k)fluoranthene	ND (< 22)	ND (< 83)	ND (< 22)
Benzo(a)pyrene	810	12,000	420
Indeno (1,2,3-c,d)pyrene	370	5,200	160
Dibenzo(a,h)anthracene	110	1,900	48
Benzo(ghi)perylene	340	140	140
Total PAHs	8,454	108,720	4,186

J = Data are estimated due to associated quality control data.

B = Analyte detected in associated blank.