

**BOARD OF EDUCATION OF THE TOWNSHIP OF
DELANCO SCHOOL DISTRICT
DELANCO, NEW JERSEY**



**COMPREHENSIVE ANNUAL FINANCIAL REPORT
FOR THE FISCAL YEAR ENDED
JUNE 30, 2016**

TOWNSHIP OF DELANCO SCHOOL DISTRICT
Table of Contents

INTRODUCTORY SECTION	<u>Page</u>
Letter of Transmittal	2
Organizational Chart	7
Roster of Officials	8
Consultants and Advisors	9
FINANCIAL SECTION	
Independent Auditor's Report	11
Required Supplementary Information – Part I Management's Discussion and Analysis	17
Basic Financial Statements	
A. Government-Wide Financial Statements:	
A-1 Statement of Net Position	26
A-2 Statement of Activities	27
B. Fund Financial Statements:	
Governmental Funds:	
B-1 Balance Sheet	29
B-2 Statement of Revenues, Expenditures and Changes in Fund Balances	30
B-3 Reconciliation of the Statement of Revenues, Expenditures and Changes in Fund Balances of Governmental Funds to the Statement of Activities	31
Proprietary Funds:	
B-4 Statement of Net Position	32
B-5 Statement of Revenues, Expenses and Changes in Fund Net Position	33
B-6 Statement of Cash Flows	34
Fiduciary Funds:	
B-7 Statement of Fiduciary Net Position	35
B-8 Statement of Changes in Fiduciary Net Position	36
Notes to the Financial Statements	37
Required Supplementary Information – Part II	
C. Budgetary Comparison Schedules	
C-1 Budgetary Comparison Schedule – General Fund	71
C-1a Combining Schedule of Revenues, Expenditures and Changes In Fund Balance – Budget and Actual	N/A
C-1b Community Development Block Grant – Budget and Actual	N/A
C-2 Budgetary Comparison Schedule – Special Revenue Fund	82
C-3 Notes to Required Supplementary Information – Part II Budget-to-GAAP Reconciliation	83

TOWNSHIP OF DELANCO SCHOOL DISTRICT
Table of Contents (Cont'd)

	Page
Required Supplementary Information – Part III	
L. Schedules Related to Accounting and Reporting for Pensions (GASB 68)	
L-1 Schedule of the School District’s Proportionate Share of the Net Pension Liability – PERS	85
L-2 Schedule of the School District’s Contributions – PERS	86
L-3 Schedule of the School District’s Proportionate Share of the Net Pension Liability – TPAF	87
L-4 Schedule of the School District’s Contributions – TPAF	88
L-5 Notes to the Required Supplementary Information – Part III GASB 68 Pension Changes	89
Required Supplementary Information – Part IV (if applicable)	
L-6 Schedule of Funding Progress for Health Benefits Plan	91
L-7 Notes to the Required Supplementary Information – Part IV	92
Other Supplementary Information	
D. School Based Budget Schedules:	
D-1 Combining Balance Sheet	N/A
D-2 Blended Resource Fund – Schedule of Expenditures Allocated by Resource Type – Actual	N/A
D-3 Blended Resource Fund – Schedule of Blended Expenditures – Budget and Actual	N/A
E. Special Revenue Fund:	
E-1 Combining Schedule of Program Revenues and Expenditures – Budgetary Basis	95
E-2 Preschool Education Aid Schedule(s) of Expenditures – Budgetary Basis	N/A
F. Capital Projects Fund:	
F-1 Summary Schedule of Project Expenditures	N/A
F-2 Summary Schedule of Revenues, Expenditures, and Changes in Fund Balances – Budgetary Basis	N/A
F-2a Schedule(s) of Project Revenues, Expenditures, Project Balance and Project Status - Budgetary Basis	N/A

TOWNSHIP OF DELANCO SCHOOL DISTRICT
Table of Contents (Cont'd)

	Page
Other Supplementary Information (Cont'd)	
G. Proprietary Funds:	
Enterprise Fund:	
G-1 Combining Statement of Net Position	97
G-2 Combining Statement of Revenues, Expenses and Changes in Fund Net Position	98
G-3 Combining Statement of Cash Flows	99
Internal Service Fund:	
G-4 Statement of Net Position	100
G-5 Statement of Revenues, Expenses and Changes in Fund Net Position	101
G-6 Statement of Cash Flows	102
H. Fiduciary Funds:	
H-1 Combining Statement of Fiduciary Net Position	104
H-2 Statement of Changes in Fiduciary Net Position	105
H-3 Student Activity Agency Fund Schedule of Receipts and Disbursements	106
H-4 Payroll Agency Fund Schedule of Receipts and Disbursements	107
I. Long-Term Debt:	
I-1 Schedule of Serial Bonds	109
I-2 Schedule of Obligations under Capital Leases	N/A
I-3 Debt Service Fund Budgetary Comparison Schedule	110

STATISTICAL SECTION (Unaudited)

Introduction to the Statistical Section

Financial Trends

J-1 Net Position by Component	113
J-2 Changes in Net Position	114
J-3 Fund Balances—Governmental Funds	116
J-4 Changes in Fund Balances—Governmental Funds	117
J-5 General Fund Other Local Revenue by Source	118

Revenue Capacity

J-6 Assessed Value and Estimated Actual Value of Taxable Property	120
J-7 Direct and Overlapping Property Tax Rates	121
J-8 Principal Property Taxpayers	122
J-9 Property Tax Levies and Collections	123

Debt Capacity

J-10 Ratios of Outstanding Debt by Type	125
J-11 Ratios of General Bonded Debt Outstanding	126
J-12 Direct and Overlapping Governmental Activities Debt	127
J-13 Legal Debt Margin Information	128

TOWNSHIP OF DELANCO SCHOOL DISTRICT
Table of Contents (Cont'd)

	Page
Statistical Section (Cont'd)	
Demographic and Economic Information	
J-14 Demographic and Economic Statistics	130
J-15 Principal Employers	131
Operating Information	
J-16 Full-time Equivalent District Employees by Function/Program	133
J-17 Operating Statistics	134
J-18 School Building Information	135
J-19 Schedule of Required Maintenance Expenditures by School Facility	136
J-20 Insurance Schedule	137
 SINGLE AUDIT SECTION 	
K-1 Report on Internal Control Over Financial Reporting and on Compliance And Other Matters Based on an Audit of Financial Statements Performed in Accordance with Government Auditing Standards	14
K-2 Report on Compliance for Each Major Program and Report on Internal Control Over Compliance Required by State of New Jersey Circular 15-08-OMB	139
K-3 Schedule of Expenditures of Federal Awards, Schedule A	141
K-4 Schedule of Expenditures of State Financial Assistance, Schedule B	143
K-5 Notes to Schedules of Expenditures of Federal Awards and State Financial Assistance	145
K-6 Schedule of Findings and Questioned Costs	147
K-7 Summary Schedule of Prior Audit Findings and Questioned Costs as Prepared by Management	152

INTRODUCTORY SECTION

Delanco Township School District

1301 Burlington Avenue, Delanco, New Jersey 08075



November 30, 2016

Honorable President and
Members of the Board of Education
Delanco Township School District
1301 Burlington Avenue
Delanco, New Jersey 08075

Dear Board Members:

The Comprehensive Annual Financial Report of the Delanco School District (School District) for the fiscal year ended June 30, 2016 is hereby submitted. Responsibility for both the accuracy of the data and completeness and fairness of the presentation, including all disclosures, rests with the management of the Board of Education. To the best of our knowledge and belief, the data presented in this report is accurate in all material respects and is reported in a manner designed to present fairly the financial position and results of operations of the governmental activities, the business type activities, each major fund, and the aggregate remaining fund information of the School District. All disclosures necessary to enable the reader to gain an understanding of the School District's financial activities have been included.

The comprehensive annual financial report is presented in four sections: introductory, financial, statistical and single audit. The introductory section includes this transmittal letter, the School District's organizational chart and a list of principal officials. The financial section includes management's discussion and analysis, the basic financial statements and schedules, as well as the independent auditor's report thereon. The statistical section includes selected financial and demographic information, generally presented on a multi-year basis. The School District is required to undergo an annual single audit in conformity with the provisions of Title 2 U.S. Code of Federal Regulations Part 200, *Uniform Administrative Requirements, Cost Principles, and Audit Requirements for Federal Awards* (Uniform Guidance) and the New Jersey State Treasury Circular 15-08-OMB, *Single Audit Policy for Recipients of Federal Grants, State Grants and State Aid*. Information related to this single audit, including the auditor's report on the internal control structure and compliance with applicable laws and regulations and findings and recommendations, are included in the single audit section of this report.

1) REPORTING ENTITY AND ITS SERVICES: Delanco School District is an independent reporting entity within the criteria adopted by the GASB as established by NCGA Statement No. 3. All funds of the School District are included in this report. The Delanco Board of Education, Walnut Street School, and M. Joan Pearson School constitute the School District's reporting entity.

The School District provides a full range of educational services appropriate to grade levels K through 8. These services include regular education, as well as special education for disabled youngsters. The School District completed the 2015-2016 fiscal year with an enrollment of 392 students, which is 5 students above the previous year's enrollment. The following details the changes in the student average daily enrollment of the School District over the last ten years.

Average Daily Enrollment

<u>Fiscal Year</u>	<u>Student Enrollment Average</u>	<u>Percent Change</u>
2015-16	392	1.29%
2014-15	387	(0.73%)
2013-14	390	1.00%
2012-13	386	(1.78%)
2011-12	393	1.94%
2010-11	386	(2.89%)
2009-10	397	1.79%
2008-09	390	(0.36%)
2007-08	391	6.07%
2006-07	369	2.79%

Students in grades kindergarten through fifth are housed in the M. Joan Pearson School and grades sixth through eighth in the Walnut Street School. For grades ninth through twelfth students are sent to Riverside High School on a tuition basis.

2) ECONOMIC CONDITION AND OUTLOOK: The School District had previously seen growth in student population from new housing developments. The School District experienced an enrollment increase between the 2005/2006 and 2006/2007 of 30 students. With the present state of the economy the growth has not continued. Construction projects were completed for both schools in 2006. The project prepared the School District for growth, upgraded facility needs, and added an administration wing to the M. Joan Pearson School.

The School District experienced a negative adjustment of \$650,049.00 in its State aid payments during the 2009/2010 fiscal year as ordered by the State of New Jersey to address its fiscal crisis. To replace these funds the School District dissolved its Maintenance and Emergency Reserves, and froze expenditures except for those that were crucial. The State continues to withhold the month of June's last two State Aid payments for the fiscal year. The payments are released during the month of July. For the 2015-2016 school year budget the amount withheld totaled \$209,013.00.

The Board of Education adopted a resolution on February 8, 2012 eliminating the annual April school election. If the budget adopted by the Board of Education exceeds the State allowable tax cap increase of 2%, a question will then be presented to Delanco voters at the November general election to exceed the cap. Board of Education member candidates will also be on the November general election ballot. Successful candidates are to be sworn in at the annual reorganization meeting which was moved from May to January.

3) MAJOR INITIATIVES: Currently, the School District has no major initiatives.

4) INTERNAL ACCOUNTING CONTROLS: Management of the School District is responsible for establishing and maintaining an internal control structure designed to ensure that the assets of the School District are protected from loss, theft or misuse and to ensure that adequate accounting data are compiled to allow for the preparation of financial statements in conformity with generally accepted accounting principles (GAAP). The internal control structure is designed to provide reasonable, but not absolute, assurance that these objectives are met. The concept of reasonable assurance recognizes that: (1) the cost of a control should not exceed the benefits likely to be derived; and (2) the valuation of costs and benefits requires estimates and judgments by management.

As a recipient of federal awards and state financial assistance, the School District also is responsible for insuring that an adequate internal control structure is in place to ensure compliance with applicable laws and regulations related to those programs. This internal control structure is also subject to periodic evaluation by the School District management. As part of the School District's single audit described earlier, tests are made to determine the adequacy of the internal control structure, including that portion related to federal awards and state financial assistance programs, as well as to determine that the School District has complied with applicable laws and regulations.

5) BUDGETARY CONTROLS: In addition to internal accounting controls, the School District maintains budgetary controls. The objective of these budgetary controls is to ensure compliance with legal provisions embodied in the annual appropriated budget adopted by the Board of Education. Annual appropriated budgets are adopted for the general fund, the special revenue fund, and the debt service fund. The final budget amount as amended for the fiscal year is reflected in the financial section.

An encumbrance accounting system is used to record outstanding purchase order commitments on a line item basis. Open encumbrances at year-end are either cancelled or are included as re-appropriations of fund balance in the subsequent year. Those amounts to be re-appropriated are reported as assignments of fund balance at June 30.

6) ACCOUNTING SYSTEM AND REPORTS: The School District's accounting records reflect generally accepted accounting principles, as promulgated by the Governmental Accounting Standards Board (GASB). The accounting system of the School District is organized on the basis of funds. These funds are explained in "Notes to the Financial Statements", Note 1.

7) CASH MANAGEMENT: The investment policy of the School District is guided in large part by state statute as detailed in "Notes to the Financial Statements", Note 2. The School District has adopted a cash management plan which requires it to deposit public funds in public depositories protected from loss under the provisions of the Governmental Unit Deposit Protection Act ("GUDPA"). GUDPA was enacted in 1970 to protect Governmental Units from a loss of funds on deposit with a failed banking institution in New Jersey. The law requires governmental units to deposit public funds only in public depositories located in New Jersey, where the funds are secured in accordance with the Act.

8) RISK MANAGEMENT: The Board carries various forms of insurance, including but not limited to general liability, automobile liability and comprehensive/collision, hazard and theft insurance on property and contents, and fidelity bonds.

9) DEBT ADMINISTRATION: The board refunded its 2005 bond issue in April of 2013 and realized significant savings. As of June 30, 2016 the School District's outstanding debt issues includes \$5,455,000.00 in general obligation bonds.

10) OTHER INFORMATION: State statutes require an annual audit by independent certified public accountants. The accounting firm of Bowman & Company LLP was selected by the Board. In addition to meeting the requirements set forth in state statutes, the audit also was designed to meet the requirements of Title 2 U.S. Code of Federal Regulations Part 200, *Uniform Administrative Requirements, Cost Principles, and Audit Requirements for Federal Awards* (Uniform Guidance) and the New Jersey State Treasury Circular 15-08-OMB, *Single Audit Policy for Recipients of Federal Grants, State Grants and State Aid*. The auditor's report on the basic financial statements and combining and individual fund statements and schedules is included in the financial section of this report. The auditor's reports related specifically to the single audit are included in the single audit section of this report.

11) ACKNOWLEDGMENTS: A successful Comprehensive Annual Financial Report depends on the support of the staff, parents, and community, and includes a vision of the members Delanco Board of Education to dedicate itself to excellence. The Board of Education's commitment provides fiscal accountability to the citizens and taxpayers of the School District. Their continued support to the development and maintenance of the financial operations of the School District is to be commended. The outstanding efforts and dedication of the Administration and their staff, and especially the staff of the Board of Education Office, are most important to the successful findings in this report.

Respectfully submitted,

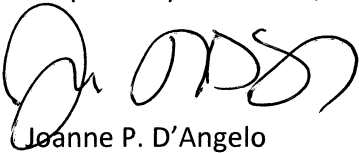

Joanne P. D'Angelo
School Business Administrator/
Board Secretary

DELANCO TOWNSHIP BOARD OF EDUCATION
ORGANIZATIONAL CHART

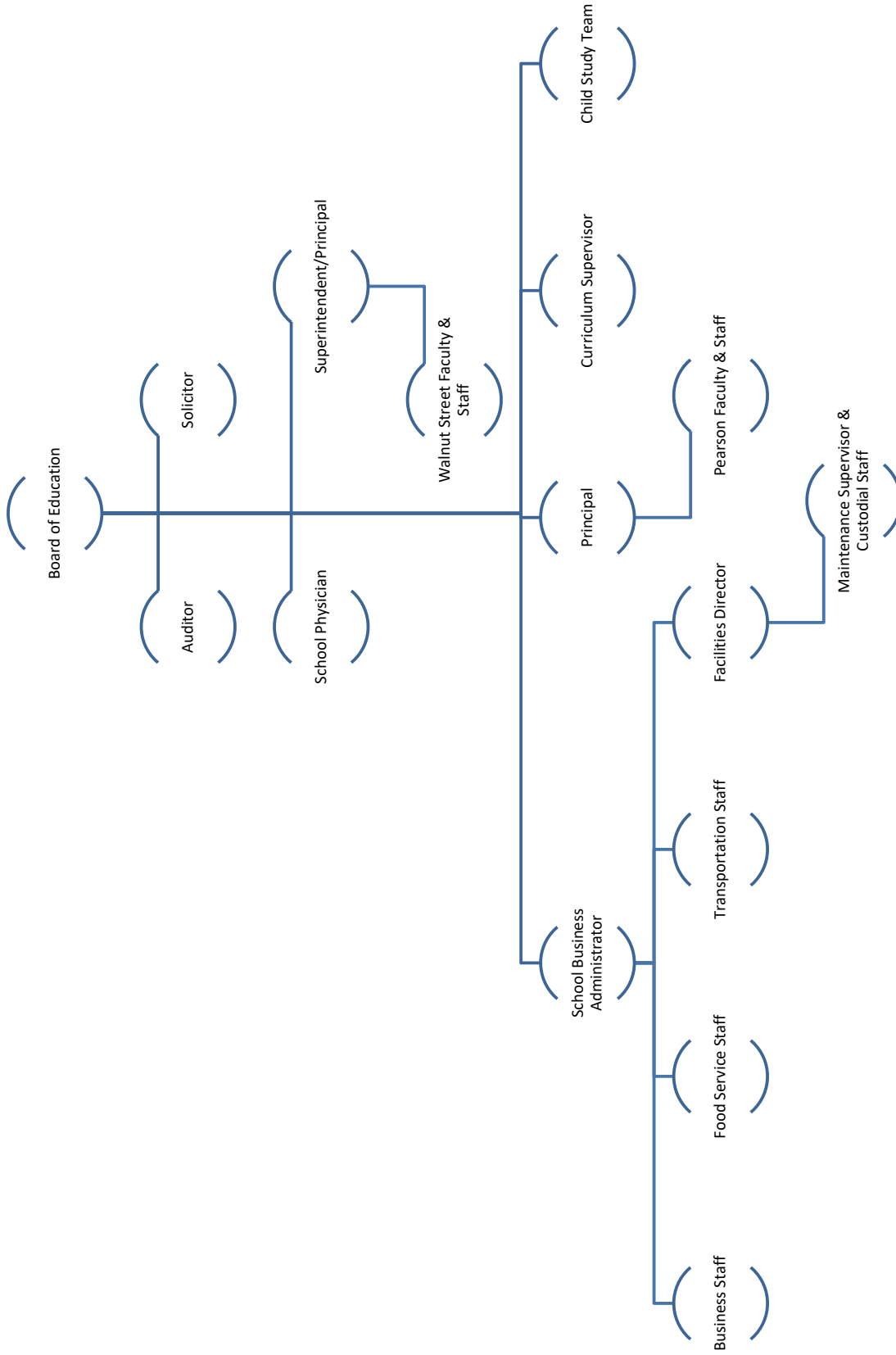

**DELANCO BOARD OF EDUCATION
DELANCO, NEW JERSEY**

ROSTER OF OFFICIALS
JUNE 30, 2016

Members of the Board of Education	<u>Term Expires</u>
Phil Jenkins, President	2018
Kenneth Adams	2017
Paul Hamlin	2016
Marisa Karamanoogian	2016
Rose Gonteski	2017
Eric Hoffman	2018
Harry Litwack	2016
Cynthia Wagstaff	2018
Steven Lohr	2017
Other Officials	
Joseph Mersinger, Superintendent/Principal	
Joanne D'Angelo, School Business Administrator/Board Secretary	
Parker McCay, Solicitor	

DELANCO BOARD OF EDUCATION

CONSULTANTS AND ADVISORS

Audit Firm

Bowman & Company LLP
601 White Horse Road
Voorhees, NJ 08043

Attorney

Parker McCay
9000 Midlantic Drive Suite 300
PO Box 5054
Mount Laurel, NJ 08054

Official Depositories

Investors Bank
80 Hartford Road
Moorestown, NJ 08057

Delanco Federal Savings Bank
615 Burlington Avenue
Delanco, NJ 08075

ABCO Federal Credit Union
690 Beverly Rancocas Road
Willingboro, NJ 08046

FINANCIAL SECTION

INDEPENDENT AUDITOR'S REPORT

The Honorable President and
Members of the Board of Education
Township of Delanco School District
Delanco, New Jersey 08075

Report on the Financial Statements

We have audited the accompanying financial statements of the governmental activities, the business-type activities, each major fund, and the aggregate remaining fund information of the Township of Delanco School District, in the County of Burlington, State of New Jersey, as of and for the fiscal year ended June 30, 2016, and the related notes to the financial statements, which collectively comprise the School District's basic financial statements as listed in the table of contents.

Management's Responsibility for the Financial Statements

Management is responsible for the preparation and fair presentation of these financial statements in accordance with accounting principles generally accepted in the United States of America; this includes the design, implementation, and maintenance of internal control relevant to the preparation and fair presentation of financial statements that are free from material misstatement, whether due to fraud or error.

Auditor's Responsibility

Our responsibility is to express opinions on these financial statements based on our audit. We conducted our audit in accordance with auditing standards generally accepted in the United States of America; the standards applicable to financial audits contained in *Government Auditing Standards*, issued by the Comptroller General of the United States; and in compliance with audit requirements as prescribed by the Division of Administration and Finance, Department of Education, State of New Jersey. Those standards require that we plan and perform the audit to obtain reasonable assurance about whether the financial statements are free from material misstatement.

An audit involves performing procedures to obtain audit evidence about the amounts and disclosures in the financial statements. The procedures selected depend on the auditor's judgment, including the assessment of the risks of material misstatement of the financial statements, whether due to fraud or error. In making those risk assessments, the auditor considers internal control relevant to the School District's preparation and fair presentation of the financial statements in order to design audit procedures that are appropriate in the circumstances, but not for the purpose of expressing an opinion on the effectiveness of the School District's internal control. Accordingly, we express no such opinion. An audit also includes evaluating the appropriateness of accounting principles used and the reasonableness of significant accounting estimates made by management, as well as evaluating the overall presentation of the financial statements.

We believe that the audit evidence we have obtained is sufficient and appropriate to provide a basis for our audit opinions.

Opinions

In our opinion, the financial statements referred to above present fairly, in all material respects, the respective financial position of the governmental activities, the business-type activities, each major fund, and the aggregate remaining fund information of the Township of Delanco School District, in the County of Burlington, State of New Jersey, as of June 30, 2016, and the respective changes in financial position and, where applicable, cash flows thereof for the fiscal year then ended in accordance with accounting principles generally accepted in the United States of America.

Other Matters

Required Supplementary Information

Accounting principles generally accepted in the United States of America require that the management's discussion and analysis, budgetary comparison information, schedule of the School District's proportionate share of the net pension liability, schedule of the School District's contributions, and schedule of funding progress for health benefits plan, as listed in the table of contents, be presented to supplement the basic financial statements. Such information, although not a part of the basic financial statements, is required by the Governmental Accounting Standards Board who considers it to be an essential part of financial reporting for placing the basic financial statements in an appropriate operational, economic, or historical context. We have applied certain limited procedures to the required supplementary information in accordance with auditing standards generally accepted in the United States of America, which consisted of inquiries of management about the methods of preparing the information and comparing the information for consistency with management's responses to our inquiries, the basic financial statements, and other knowledge we obtained during our audit of the basic financial statements. We do not express an opinion or provide any assurance on the information because the limited procedures do not provide us with sufficient evidence to express an opinion or provide any assurance.

Other Information

Our audit was conducted for the purpose of forming opinions on the financial statements that collectively comprise the Township of Delanco School District's basic financial statements. The introductory section, combining statements and related major fund supporting statements and schedules, statistical section, and schedule of expenditures of federal awards are presented for purposes of additional analysis, as required by the Division of Administration and Finance, Department of Education, State of New Jersey, and are not a required part of the basic financial statements. The accompanying schedule of expenditures of state financial assistance, as required by State of New Jersey Circular 15-08-OMB, *Single Audit Policy for Recipients of Federal Grants, State Grants and State Aid*, is also presented for purposes of additional analysis and is not a required part of the basic financial statements.

The accompanying combining statements and related major fund supporting statements and schedules and schedules of expenditures of federal awards and state financial assistance are the responsibility of management and were derived from and relate directly to the underlying accounting and other records used to prepare the basic financial statements. Such information has been subjected to the auditing procedures applied in the audit of the basic financial statements and certain additional procedures, including comparing and reconciling such information directly to the underlying accounting and other records used to prepare the basic financial statements or to the basic financial statements themselves, and other additional procedures in accordance with auditing standards generally accepted in the United States of America. In our opinion, the accompanying combining statements and related major fund supporting statements and schedules and schedules of expenditures of federal awards and state financial assistance are fairly stated, in all material respects, in relation to the basic financial statements as a whole.

The introductory section and statistical section listed in the table of contents have not been subjected to the auditing procedures applied in the audit of the basic financial statements, and accordingly, we do not express an opinion or provide any assurance on them.

21800

Other Reporting Required by Government Auditing Standards

In accordance with *Government Auditing Standards*, we have also issued our report dated November 30, 2016 on our consideration of the Township of Delanco School District's internal control over financial reporting and on our tests of its compliance with certain provisions of laws, regulations, contracts, and grant agreements and other matters. The purpose of that report is to describe the scope of our testing of internal control over financial reporting and compliance and the results of that testing, and not to provide an opinion on internal control over financial reporting or on compliance. That report is an integral part of an audit performed in accordance with *Government Auditing Standards* in considering the Township of Delanco School District's internal control over financial reporting and compliance.

Respectfully submitted,

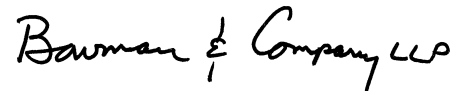

BOWMAN & COMPANY LLP
Certified Public Accountants
& Consultants



Robert P. Nehila Jr.
Certified Public Accountant
Public School Accountant No. CS 002065

Voorhees, New Jersey
November 30, 2016

**REPORT ON INTERNAL CONTROL OVER FINANCIAL REPORTING AND ON COMPLIANCE
AND OTHER MATTERS BASED ON AN AUDIT OF FINANCIAL STATEMENTS PERFORMED IN
ACCORDANCE WITH GOVERNMENT AUDITING STANDARDS**

INDEPENDENT AUDITOR'S REPORT

The Honorable President and
Members of the Board of Education
Township of Delanco School District
Delanco, New Jersey 08075

We have audited, in accordance with the auditing standards generally accepted in the United States of America, the standards applicable to financial statement audits contained in *Government Auditing Standards*, issued by the Comptroller General of the United States, and in compliance with audit requirements as prescribed by the Division of Administration and Finance, Department of Education, State of New Jersey, the financial statements of the governmental activities, the business-type activities, each major fund, and the aggregate remaining fund information of the Township of Delanco School District, in the County of Burlington, State of New Jersey, as of and for the fiscal year ended June 30, 2016, and the related notes to the financial statements, which collectively comprise the School District's basic financial statements, and have issued our report thereon dated November 30, 2016.

Internal Control Over Financial Reporting

In planning and performing our audit of the financial statements, we considered the Township of Delanco School District's internal control over financial reporting (internal control) to determine the audit procedures that are appropriate in the circumstances for the purpose of expressing our opinions on the financial statements, but not for the purpose of expressing an opinion on the effectiveness of the School District's internal control. Accordingly, we do not express an opinion on the effectiveness of the Township of Delanco School District's internal control.

A deficiency in internal control exists when the design or operation of a control does not allow management or employees, in the normal course of performing their assigned functions, to prevent, or detect and correct, misstatements on a timely basis. *A material weakness* is a deficiency, or combination of deficiencies, in internal control, such that there is a reasonable possibility that a material misstatement of the entity's financial statements will not be prevented, or detected and corrected on a timely basis. *A significant deficiency* is a deficiency, or a combination of deficiencies, in internal control that is less severe than a material weakness, yet important enough to merit attention by those charged with governance.

Our consideration of internal control was for the limited purpose described in the first paragraph of this section and was not designed to identify all deficiencies in internal control that might be material weaknesses or significant deficiencies. Given these limitations, during our audit we did not identify any deficiencies in internal control that we consider to be material weaknesses. However, material weaknesses may exist that have not been identified.

Compliance and Other Matters

As part of obtaining reasonable assurance about whether the Township of Delanco School District's financial statements are free from material misstatement, we performed tests of its compliance with certain provisions of laws, regulations, contracts, and grant agreements, noncompliance with which could have a direct and material effect on the determination of financial statement amounts. However, providing an opinion on compliance with those provisions was not an objective of our audit, and accordingly, we do not express such an opinion. The results of our tests disclosed no instances of noncompliance or other matters that are required to be reported under *Government Auditing Standards*, and audit requirements as prescribed by the Division of Administration and Finance, Department of Education, State of New Jersey.

Purpose of this Report

The purpose of this report is solely to describe the scope of our testing of internal control and compliance and the results of that testing, and not to provide an opinion on the effectiveness of the entity's internal control or on compliance. This report is an integral part of an audit performed in accordance with *Government Auditing Standards* and audit requirements as prescribed by the Division of Administration and Finance, Department of Education, State of New Jersey, and federal and state awarding agencies and pass-through entities, in considering the School District's internal control and compliance. Accordingly, this communication is not suitable for any other purpose.

Respectfully submitted,

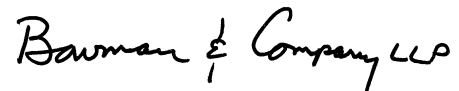

BOWMAN & COMPANY LLP
Certified Public Accountants
& Consultants



Robert P. Nehila Jr.
Certified Public Accountant
Public School Accountant No. CS 002065

Voorhees, New Jersey
November 30, 2016

REQUIRED SUPPLEMENTARY INFORMATION
PART I

TOWNSHIP OF DELANCO SCHOOL DISTRICT
Management's Discussion and Analysis
For the Fiscal Year Ended June 30, 2016
(Unaudited)

The management's discussion and analysis of the Township of Delanco School District (School District) financial performance provides an overall review of the School District's financial activities for the fiscal year ended June 30, 2016 and 2015. The intent of the discussion and analysis is to look at the School District's financial performance and review the notes to the basic financial statements to enhance the understanding of the School District's financial performance. It is recommended that the discussion and analysis be read in conjunction with a transmittal letter at the front of this financial report.

FINANCIAL HIGHLIGHTS

Financial Highlights for fiscal year 2016:

- The total assets and deferred outflows of resources of the School District exceeded its total liabilities and deferred inflows of resources at the close of the most recent fiscal year by \$9,986,795.91 (net position).
- The School District's total net position increased by \$95,734.56, from the prior fiscal year.
- As of the close of the current fiscal year, the School District's governmental funds reported combined ending fund balances of \$3,464,574.68, an increase of \$186,850.80 in comparison with the prior year.

OVERVIEW OF THE FINANCIAL STATEMENTS

This annual report consists of three parts – management's discussion and analysis (this section), the basic financial statements, and required supplementary information. The basic financial statements include two kinds of statements that present different views of the School District:

- The first two statements are *government-wide financial statements* that provide both *short-term* and *long-term* information about the School District's *overall* financial status.
- The remaining statements are *fund financial statements* that focus on *individual parts* of the School District, reporting the School District's operations *in more detail* than the government-wide statements.
- *Governmental funds* statements tell how basic services like regular and special education were financed in the *short term* as well as what remains for future spending.
- *Proprietary funds* statements offer *short* and *long-term* financial information about the activities the School District operates *like businesses*, such as food services and the ex-care program.
- *Fiduciary funds* statements provide information about the financial relationships in which the School District acts solely as a *trustee or agent* for the benefit of others.

The financial statements also include notes that explain some of the information in the statements and provide more detailed data. The statements are followed by a section of required supplementary information that further explains and supports the financial statements with a comparison of the School District's budget for the year.

Government-Wide Statements

The government-wide statements report information about the School District as a whole using accounting methods similar to those used by the private-sector companies. The statement of net position includes all of the School District's assets and liabilities. All of the current year's revenues and expenses are accounted for in the statement of activities regardless of when cash is received or paid.

TOWNSHIP OF DELANCO SCHOOL DISTRICT
Management's Discussion and Analysis
For the Fiscal Year Ended June 30, 2016
(Unaudited) (Cont'd)

OVERVIEW OF THE FINANCIAL STATEMENTS (CONT'D)

Government-Wide Statements (Cont'd)

The two government-wide statements report the School District's net position and how they have changed. Net position – the difference between the School District's assets and deferred outflows of resources and liabilities and deferred inflows of resources – is one way to measure the School District's financial health or position.

- Increase or decrease in the School District's net position is an indicator of whether its financial position is improving or deteriorating, respectively.
- To assess the overall health or position of the School District, you need to consider additional nonfinancial factors such as changes in the School District's property tax base and the condition of school buildings and other facilities.

In the government-wide financial statements, the School District's activities are divided in two categories:

- *Governmental activities* – The basic services, such as instruction for regular and special education, maintenance and operations, transportation and administration are included as government activities. Property taxes, state aid and fund balance appropriated finance most of these activities.
- *Business-type activities* – The School District charges fees to cover the costs of certain services such as the ex-care program and food services.

Fund Financial Statements

The fund financial statements provide more detailed information about the School District's funds, focusing on the significant funds – not the School District as a whole. Funds are used by the School District to keep track of specific sources of funding and spending on particular programs:

- May distinguish state or federal grants.
- Funds for capital projects and long-term debt.

The School District has three kinds of funds:

- *Governmental funds* – The School District's basic services are included in governmental funds, which detail cash and other financial assets and also identify balances that remain at year-end. Governmental funds statements provide a short-term view to determine whether more or less financial resources can be spent in subsequent years.
- *Proprietary funds* – These funds represent charges or fees for such activities as the ex-care program and food services.
- *Fiduciary funds* – The School District is the trustee for assets that belong to others. The student activities funds which include clubs and classes are maintained in this fund. The School District is responsible for ensuring that the assets reported in these funds are used only for their intended purposes. These funds are not included in the government-wide financial statements since the School District is not permitted to use these assets in the School District operation.

TOWNSHIP OF DELANCO SCHOOL DISTRICT
Management's Discussion and Analysis
For the Fiscal Year Ended June 30, 2016
(Unaudited) (Cont'd)

FINANCIAL ANALYSIS OF THE SCHOOL DISTRICT AS A WHOLE

Table 1 provides a summary of the School District's net position for fiscal years 2016 and 2015.

TABLE 1
Net Position

	<u>June 30, 2016</u>	<u>June 30, 2015</u>	<u>Change</u>	<u>% Change</u>
Current and Other Assets	\$ 3,761,994.35	\$ 3,608,088.18	\$ 153,906.17	4.27%
Capital Assets	13,711,614.25	13,996,468.67	(284,854.42)	-2.04%
Total Assets	<u>17,473,608.60</u>	<u>17,604,556.85</u>	<u>(130,948.25)</u>	<u>-0.74%</u>
Deferred Outflow of Resources - Related to Pensions	380,912.00	103,406.00	277,506.00	268.37%
Deferred Outflow of Resources - Loss on Debt	243,200.00	263,466.66	(20,266.66)	-7.69%
	<u>624,112.00</u>	<u>366,872.66</u>	<u>257,239.34</u>	<u>70.12%</u>
Long-Term Liabilities	7,643,323.55	7,526,329.03	116,994.52	1.55%
Other Liabilities	396,542.14	423,940.13	(27,397.99)	-6.46%
Total Liabilities	<u>8,039,865.69</u>	<u>7,950,269.16</u>	<u>89,596.53</u>	<u>1.13%</u>
Deferred Inflow of Resources - Related to Pensions	71,059.00	130,099.00	(59,040.00)	-45.38%
Net Position:				
Net Investment in Capital Assets	8,247,353.74	8,276,436.44	(29,082.70)	-0.35%
Restricted	3,314,780.41	3,170,434.28	144,346.13	4.55%
Unrestricted (Deficit)	(1,575,338.24)	(1,555,809.37)	(19,528.87)	1.26%
Total Net Position	<u>\$ 9,986,795.91</u>	<u>\$ 9,891,061.35</u>	<u>\$ 95,734.56</u>	<u>0.97%</u>

This is the second year of implementation for Governmental Accounting Standards Board (GASB) Statement No. 68, Accounting and Financial Reporting for Pensions - an amendment of GASB Statement No. 27, and GASB Statement No. 71, Pension Transition for Contributions Made Subsequent to the Measurement Date - an amendment of GASB No. 68. Table 2 provides an illustration of the impact that GASBS 68 and 71 had to the School District's Unrestricted Net Position.

TABLE 2
Statement of Net Position - Effect of Pension Related Items

	<u>June 30, 2016</u>	<u>June 30, 2015</u>	<u>Change</u>	<u>% Change</u>
Deferred Outflows Related to Pensions	\$ 380,912.00	\$ 103,406.00	\$ 277,506.00	100.00%
Less: Net Pension Liability	(1,657,257.00)	(1,269,984.00)	(387,273.00)	30.49%
Less: Deferred Inflows Related to Pensions	(71,059.00)	(130,099.00)	59,040.00	-100.00%
	<u>\$ (1,347,404.00)</u>	<u>\$ (1,296,677.00)</u>	<u>\$ (50,727.00)</u>	<u>3.91%</u>

TOWNSHIP OF DELANCO SCHOOL DISTRICT
Management's Discussion and Analysis
For the Fiscal Year Ended June 30, 2016
(Unaudited) (Cont'd)

FINANCIAL ANALYSIS OF THE SCHOOL DISTRICT AS A WHOLE (CONT'D)

Table 3 reflects changes in net position for fiscal years 2016 and 2015.

TABLE 3
Change in Net Position

Revenues:	<u>June 30, 2016</u>	<u>June 30, 2015</u>	<u>Change</u>	<u>% Change</u>
Program Revenues:				
Charges for Services	\$ 232,017.95	\$ 196,588.35	\$ 35,429.60	18.02%
Federal & State Categorical Grants	1,706,993.14	1,473,937.63	233,055.51	15.81%
General Revenues:				
Property Taxes	5,980,640.00	5,980,640.00		0.00%
Federal & State Grants	2,550,213.00	2,537,911.00	12,302.00	0.48%
Other	86,174.29	79,752.27	6,422.02	8.05%
Total Revenues	<u>10,556,038.38</u>	<u>10,268,829.25</u>	<u>287,209.13</u>	<u>2.80%</u>
Expenses:				
Instruction:				
Regular	2,239,306.12	2,126,654.93	112,651.19	5.30%
Special Education	582,599.32	556,872.92	25,726.40	4.62%
Other Special Instruction	57,697.64	56,758.75	938.89	1.65%
Other Instruction	33,820.02	33,145.18	674.84	2.04%
Student Services:				
Tuition	2,088,964.89	2,142,259.49	(53,294.60)	-2.49%
Student and Instruction Related	954,057.61	923,882.82	30,174.79	3.27%
School Administrative Services	184,326.67	184,765.65	(438.98)	-0.24%
General Administrative Services	369,876.30	373,402.68	(3,526.38)	-0.94%
Plant Operations and Maintenance	654,691.89	557,603.18	97,088.71	17.41%
Pupil Transportation	232,961.99	205,793.06	27,168.93	13.20%
Unallocated Benefits	2,578,535.68	2,169,768.16	408,767.52	18.84%
Interest on Long-Term Debt	206,158.97	215,375.95	(9,216.98)	-4.28%
Food Service	167,313.47	164,519.15	2,794.32	1.70%
Ex Care	109,993.25	107,559.11	2,434.14	2.26%
Total Expenses	<u>10,460,303.82</u>	<u>9,818,361.03</u>	<u>641,942.79</u>	<u>6.54%</u>
Increase (Decrease) in Net Position	95,734.56	450,468.22	(354,733.66)	-78.75%
Beginning Net Position	<u>9,891,061.35</u>	<u>9,440,593.13</u>	<u>450,468.22</u>	<u>4.77%</u>
Ending Net Position	<u>\$ 9,986,795.91</u>	<u>\$ 9,891,061.35</u>	<u>\$ 95,734.56</u>	<u>0.97%</u>

TOWNSHIP OF DELANCO SCHOOL DISTRICT
Management's Discussion and Analysis
For the Fiscal Year Ended June 30, 2016
(Unaudited) (Cont'd)

FINANCIAL ANALYSIS OF THE SCHOOL DISTRICT AS A WHOLE (CONT'D)

Governmental Activities

In 2015-2016, Governmental Activities Revenues were \$10,293,591.11 or 97.52% of total revenues.

In 2014-2015, Governmental Activities Revenues were \$9,995,342.59 or 97.34% of total revenues.

In 2015-2016, General Revenues - Property Taxes of \$5,980,640.00 made up 58.10%, and General Revenues - Federal & State Grants of \$4,162,690.44 made up 40.44% of Governmental Activities Revenues.

In 2014-2015, General Revenues - Property Taxes of \$5,980,640.00 made up 59.83%, and General Revenues - Federal & State Grants of \$3,921,743.77 made up 39.24% of Governmental Activities Revenues.

In 2015-2016, the School District's Governmental Activities expenditures increased by \$636,714.33 or 6.67%. \$476,695.44 or 4.99% of this increase was attributable to the effects of GASB 68 in fiscal year 2015-2016.

Business-Type Activities

In 2015-2016 Business-Type Activities Revenues were \$262,184.42 or 2.48% of total revenues. In 2014-2015 Business-Type Activities Revenues were \$273,394.12 or 2.66% of total revenues.

Charges for Services for Business-Type Activities were \$167,668.72 in 2015-2016 compared to \$183,289.26 in 2014-2015, an 8.52% decrease.

Operating Grants and Contributions for Business-Type Activities were \$94,515.70 in 2015-2016 compared to \$90,104.86 in 2014-2015, a 4.90% increase.

Expenses for Business-Type Activities were \$277,306.72 in 2015-2016 compared to \$272,078.26 in 2014-2015, a 1.92% increase.

General Fund Budgeting Highlights

During the fiscal 2016 school year, the Board of Education amended its general fund budget as needed. The net change in the total budget modification primarily resulted from the rollover of the prior year's encumbrances and anticipation of miscellaneous revenues.

The final budgetary basis revenue estimate was \$8,105,046.00, which was equal to the original budget.

The 2015-2016 General Fund Tax Levy was \$5,560,840.00, a decrease of \$36,461.00 or 0.06% from the 2014-2015 General Fund Tax Levy of \$5,597,301.00.

During fiscal year 2016, the School District budgeted \$5,560,840.00 and \$2,485,655.00 for property taxes (local tax levy) and state aid revenues, respectively.

The School District also received \$182,215.44, \$176,281.00, \$220,359.00 and \$8,781.00 in reimbursed T.P.A.F. Social Security Aid, T.P.A.F. Pension Contributions, T.P.A.F. Post-Retirement Medical Contributions and T.P.A.F. Non-contributory Insurance, respectively.

The final budgetary basis expenditure appropriation estimate was \$9,444,176.44, which was equal to the original budget.

TOWNSHIP OF DELANCO SCHOOL DISTRICT
 Management's Discussion and Analysis
 For the Fiscal Year Ended June 30, 2016
 (Unaudited) (Cont'd)

FINANCIAL ANALYSIS OF THE SCHOOL DISTRICT AS A WHOLE (CONT'D)

General Fund Budgeting Highlights (Cont'd)

The School District's expenditures also include reimbursed T.P.A.F. Social Security Aid, T.P.A.F. Pension Contributions, T.P.A.F. Post-Retirement Medical Contributions and T.P.A.F. Non-contributory insurance of \$182,215.44, \$176,281.00, \$220,359.00 and \$8,781.00, respectively, which contributes to an unfavorable expenditure variance for the fiscal year.

Financial Analysis of the Government's Funds

Governmental Funds - As of the end of the current fiscal year, the School District's governmental funds reported combining ending fund balances of \$3,464,574.68, an increase of \$186,850.80 in comparison with the prior year.

Of the combined ending fund balances of \$3,464,574.68, \$110,787.00 constitutes unassigned fund balance. The remainder of fund balance of \$3,353,787.68 is restricted or assigned for various purposes.

Proprietary Funds - As of the end of the current fiscal year, the School District's proprietary funds had \$95,476.59 in unrestricted net position.

CAPITAL ASSETS

At the end of fiscal year 2016 and 2015, the School District had \$13,711,614.25 and \$13,996,468.67, respectively, in capital assets less accumulated depreciation. Table 4 reflects the capital assets.

TABLE 4
 Capital Assets

Capital Assets (Net of Depreciation):	<u>June 30, 2016</u>	<u>June 30, 2015</u>
Equipment	\$ 238,042.84	\$ 247,336.68
Building and Improvements	13,467,410.16	13,740,506.24
Land Improvements	<u>6,161.25</u>	<u>8,625.75</u>
 Total Capital Assets	 <u>\$ 13,711,614.25</u>	 <u>\$ 13,996,468.67</u>

Depreciation expense was \$327,553.42 for fiscal year ended 2016 and \$337,852.15 for fiscal year ended 2015.

DEBT ADMINISTRATION

Long-term Debt - At the end of the current fiscal year, the School District had \$5,455,000.00 in bonded debt outstanding.

TOWNSHIP OF DELANCO SCHOOL DISTRICT
Management's Discussion and Analysis
For the Fiscal Year Ended June 30, 2016
(Unaudited) (Cont'd)

THE FUTURE OUTLOOK

The Delanco Township School District has been operating with a reduced administrative staff since 2012. The position of Superintendent/Principal has resulted in significant savings for the District each year. The shared service agreement with Moorestown Township School District, which allows our District to have a part-time Business Administrator, has also been successful since 2012, and likewise for the shared service agreement for technology services with Burlington Township School District, which began in 2014. Also in regard to technology, the District has recently updated all computers in two computer labs as well as in every classroom at both Walnut Street Middle School and M. Joan Pearson Elementary School. Delanco also has a long-standing shared services agreement for Child Study Team services with Riverside. In addition, Delanco has a sending-receiving relationship with Riverside for students in Grades 9-12, whereby students from Delanco Township attend Riverside Township High School. Students are also given the option to apply to the Burlington County Institute of Technology as well as pursue educational opportunities at local private schools such as Holy Cross Academy and Doane Academy. In recent years, the curricula in Delanco Township have been aligned to the Common Core State Standards to prepare our students for PARCC testing. In addition, the MLP OASYS evaluation system is used to ensure educator effectiveness under the statewide Achieve NJ initiative.

CONTACTING THE SCHOOL DISTRICT'S FINANCIAL MANAGEMENT

This financial report is designed to provide a general overview of the Township of Delanco School District's finances for all those with an interest in the government's finances. Questions concerning any of the information provided in this report or requests for additional financial information should be addressed to Joanne D'Angelo, Business Administrator/Board Secretary at 1301 Burlington Avenue, Delanco, New Jersey 08075.

BASIC FINANCIAL STATEMENTS

GOVERNMENT-WIDE FINANCIAL STATEMENTS

TOWNSHIP OF DELANCO SCHOOL DISTRICT
Statement of Net Position
June 30, 2016

	Governmental <u>Activities</u>	Business-Type <u>Activities</u>	<u>Total</u>
ASSETS:			
Cash and Cash Equivalents	\$ 2,951,834.14	\$ 27,497.63	\$ 2,979,331.77
Receivables, net	253,682.25	6,181.84	259,864.09
Restricted Cash and Cash Equivalents	519,368.14		519,368.14
Inventories		3,430.35	3,430.35
Capital Assets, net (Note 6)	<u>13,650,093.86</u>	<u>61,520.39</u>	<u>13,711,614.25</u>
Total Assets	<u>17,374,978.39</u>	<u>98,630.21</u>	<u>17,473,608.60</u>
DEFERRED OUTFLOWS OF RESOURCES:			
Related to Pensions (Note 9)	380,912.00		380,912.00
Deferred Loss on Defeasance of Debt	<u>243,200.00</u>		<u>243,200.00</u>
	<u>624,112.00</u>	<u>-</u>	<u>624,112.00</u>
LIABILITIES:			
Accounts Payable:			
Related to Pension	68,167.00		68,167.00
Other	259,671.98	526.96	260,198.94
Accrued Interest	64,911.67		64,911.67
Unearned Revenue	637.87	2,626.66	3,264.53
Noncurrent Liabilities (Note 7):			
Due within One Year	275,000.00		275,000.00
Due beyond One Year	<u>7,368,323.55</u>		<u>7,368,323.55</u>
Total Liabilities	<u>8,036,712.07</u>	<u>3,153.62</u>	<u>8,039,865.69</u>
DEFERRED INFLOWS OF RESOURCES:			
Related to Pensions (Note 9)	<u>71,059.00</u>		<u>71,059.00</u>
NET POSITION:			
Net Investment in Capital Assets	8,185,833.35	61,520.39	8,247,353.74
Restricted for:			
Debt Service	5,554.43		5,554.43
Other Purposes	3,309,225.98		3,309,225.98
Unrestricted (Deficit)	<u>(1,609,294.44)</u>	<u>33,956.20</u>	<u>(1,575,338.24)</u>
Total Net Position	<u>\$ 9,891,319.32</u>	<u>\$ 95,476.59</u>	<u>\$ 9,986,795.91</u>

The accompanying Notes to Financial Statements are an integral part of this statement.

TOWNSHIP OF DELANCO SCHOOL DISTRICT
Statement of Activities
For the Fiscal Year Ended June 30, 2016

Functions / Programs	Program Revenues			Net (Expense) Revenue and Changes in Net Position			
	Expenses	Charges for Services	Operating Grants and Contributions	Capital Grants and Contributions	Governmental Activities	Business-Type Activities	Total
Governmental Activities:							
Instruction:							
Regular	\$ 2,239,306.12	\$ 55,264.00	\$ -	\$ -	\$ (2,184,042.12)	\$ -	\$ (2,184,042.12)
Special Education	582,599.32		87,338.00		(495,261.32)		(495,261.32)
Other Special Instruction	57,697.64				(57,697.64)		(57,697.64)
Other Instruction	33,820.02				(33,820.02)		(33,820.02)
Support Services:							
Tuition	2,088,964.89				(2,088,964.89)		(2,088,964.89)
Student and Instruction Related Services	954,057.61		164,571.00		(789,486.61)		(789,486.61)
School Administrative Services	184,326.67	9,085.23			(175,241.44)		(175,241.44)
General and Business Administrative Services	369,876.30				(369,876.30)		(369,876.30)
Plant Operations and Maintenance	654,691.89				(654,691.89)		(654,691.89)
Pupil Transportation	232,961.99				(232,961.99)		(232,961.99)
Unallocated Benefits	2,578,535.68		1,360,568.44		(1,217,967.24)		(1,217,967.24)
Interest on Long-Term Debt	206,158.97				(206,158.97)		(206,158.97)
Total Governmental Activities	10,182,997.10	64,349.23	1,612,477.44	-	(8,506,170.43)	-	(8,506,170.43)
Business-Type Activities:							
Food Service	167,313.47	69,747.75	94,515.70			(3,050.02)	(3,050.02)
Ex Care	109,993.25	97,920.97				(12,072.28)	(12,072.28)
Total Business-Type Activities	277,306.72	167,668.72	94,515.70	-	-	(15,122.30)	(15,122.30)
Total Primary Government	\$ 10,460,303.82	\$ 232,017.95	\$ 1,706,993.14	\$ -	(8,506,170.43)	(15,122.30)	(8,521,292.73)
General Revenues:							
Taxes:							
Property Taxes, Levied for General Purposes, net					5,560,840.00		5,560,840.00
Property Taxes Levied for Debt Service					419,800.00		419,800.00
Federal and State Aid not Restricted					2,550,213.00		2,550,213.00
Miscellaneous Income					85,911.44	262.85	86,174.29
Total General Revenues					8,616,764.44	262.85	8,617,027.29
Change in Net Position					110,594.01	(14,859.45)	95,734.56
Net Position -- July 1					9,780,725.31	110,336.04	9,891,061.35
Net Position -- June 30					\$ 9,891,319.32	\$ 95,476.59	\$ 9,986,795.91

The accompanying Notes to Financial Statements are an integral part of this statement.

FUND FINANCIAL STATEMENTS

TOWNSHIP OF DELANCO SCHOOL DISTRICT
 Governmental Funds
 Balance Sheet
 June 30, 2016

	General Fund	Special Revenue Fund	Capital Projects Fund	Debt Service Fund	Total Governmental Funds
ASSETS:					
Cash and Cash Equivalents	\$ 2,951,834.14	\$ -	\$ -	\$ 5,554.43	\$ 2,957,388.57
Receivables, net:					
Interfunds Receivable:					
Fiduciary Fund - Payroll	49.37				49.37
Special Revenue Fund	31,031.76				31,031.76
Receivables from Other Governments:					
Federal		173,199.00			173,199.00
State of New Jersey - Other	78,844.28				78,844.28
Other Receivables	1,589.60				1,589.60
Cash and Cash Equivalents - Restricted	513,175.84				513,175.84
Total Assets	\$ 3,576,524.99	\$ 173,199.00	\$ -	\$ 5,554.43	\$ 3,755,278.42
LIABILITIES AND FUND BALANCES:					
Liabilities:					
Accounts Payable	\$ 117,504.74	\$ 142,167.24	\$ -	\$ -	\$ 259,671.98
Interfunds Payable:					
General Fund		31,031.76			31,031.76
Total Liabilities	117,504.74	173,199.00	-	-	290,703.74
Fund Balances:					
Restricted:					
Capital Reserve Account	513,175.84				513,175.84
Excess Surplus -- Designated for Subsequent Year's Expenditures	1,344,935.78				1,344,935.78
Excess Surplus -- Current Year	1,451,114.36				1,451,114.36
Debt Service -- Designated for Subsequent Year's Expenditures				5,554.43	5,554.43
Assigned:					
Other Purposes	1,385.05				1,385.05
Designated for Subsequent Year's Expenditures	37,622.22				37,622.22
Unassigned	110,787.00				110,787.00
Total Fund Balances	3,459,020.25	-	-	5,554.43	3,464,574.68
Total Liabilities and Fund Balances	\$ 3,576,524.99	\$ 173,199.00	\$ -	\$ 5,554.43	

Amounts reported for *governmental activities* in the statement of net position (A-1) are different because:

Capital assets used in governmental activities are not financial resources and therefore are not reported in the funds. The cost of the assets is \$17,963,623.55, and the accumulated depreciation is \$4,313,529.69.	13,650,093.86
Deferred loss on defeasance of debt is a consumption of net position that is applicable to a future reporting period and therefore is not reported in the funds.	243,200.00
Interest on long term debt is accrued on the Statement of Net Position regardless when due.	(64,911.67)
Long-term liabilities, including bonds payable, are not due and payable in the current period and therefore are not reported as liabilities in the funds.	(5,986,066.55)
Net Pension Liability	(1,657,257.00)
Accounts Payable related to the April 1, 2017 Required PERS pension contribution that is not to be liquidated with current financial resources.	(68,167.00)
Deferred Outflows of Resources - Related to Pensions	380,912.00
Deferred Inflows of Resources - Related to Pensions	(71,059.00)
Net Position of Governmental Activities	\$ 9,891,319.32

The accompanying Notes to Financial Statements are an integral part of this statement.

TOWNSHIP OF DELANCO SCHOOL DISTRICT
 Governmental Funds
 Statement of Revenues, Expenditures and Changes in Fund Balances
 For the Fiscal Year Ended June 30, 2016

	General Fund	Special Revenue Fund	Capital Projects Fund	Debt Service Fund	Total Governmental Funds
REVENUES:					
Local Tax Levy	\$ 5,560,840.00	\$ -	\$ -	\$ 419,800.00	\$ 5,980,640.00
Miscellaneous	133,139.69	8,000.00		20.10	141,159.79
State Sources	3,145,849.44				3,145,849.44
Federal Sources		243,909.00			243,909.00
Total Revenues	8,839,829.13	251,909.00	-	419,820.10	9,511,558.23
EXPENDITURES:					
Current:					
Regular Instruction	1,943,895.93				1,943,895.93
Special Education Instruction	495,261.32	87,338.00			582,599.32
Other Special Instruction	57,697.64				57,697.64
Other Instruction	33,820.02				33,820.02
Support Services and Undistributed Costs:					
Tuition	2,088,964.89				2,088,964.89
Student and Instruction Related Services	789,486.61	164,571.00			954,057.61
School Administrative Services	179,168.08				179,168.08
Other Administrative Services	369,876.30				369,876.30
Plant Operations and Maintenance	641,524.37				641,524.37
Pupil Transportation	224,239.68				224,239.68
Unallocated Benefits	1,740,478.49				1,740,478.49
Debt Service:					
Principal				255,000.00	255,000.00
Interest and Other Charges	45,886.00			164,800.10	210,686.10
Capital Outlay	42,699.00				42,699.00
Total Expenditures	8,652,998.33	251,909.00	-	419,800.10	9,324,707.43
Net Change in Fund Balances	186,830.80			20.00	186,850.80
Fund Balance -- July 1	3,272,189.45	-	-	5,534.43	3,277,723.88
Fund Balance -- June 30	\$ 3,459,020.25	\$ -	\$ -	\$ 5,554.43	\$ 3,464,574.68

The accompanying Notes to Financial Statements are an integral part of this statement.

TOWNSHIP OF DELANCO SCHOOL DISTRICT
 Reconciliation of the Statement of Revenues, Expenditures
 and Changes in Fund Balances of Governmental Funds
 to the Statement of Activities
 For the Fiscal Year Ended June 30, 2016

Total Net Change in Fund Balances - Governmental Funds	\$ 186,850.80
Amounts reported for governmental activities in the statement of activities (A-2) are different because:	
Capital outlays are reported in governmental funds as expenditures. However, in the statement of activities, the cost of those assets is allocated over their estimated useful lives as depreciation expense. This is the amount by which capital outlays exceeded depreciation in the period.	
Depreciation Expense	\$ (317,300.02)
Capital Outlays	<u>42,699.00</u>
Repayment of bond principal is an expenditure in the governmental funds, but the repayment reduces long-term liabilities in the statement of net position and is not reported in the statement of activities.	(274,601.02)
In the statement of activities, interest on long-term debt in the statement of activities is accrued, regardless of when due. In the governmental funds, interest is reported when due. The decrease in accrued interest is an addition in the reconciliation. (+)	255,000.00
In the statement of activities, certain operating expenses, e.g., other post employment benefits are measured by the change in the amounts due during the year. In the governmental funds, however, expenditures for these items are reported in the amount of financial resources used (paid).	4,527.13
In the statement of activities, certain operating expenses, e.g., compensated absences (vacations) are measured by the amounts earned during the year. In the governmental funds, however, expenditures for these items are reported in the amount of financial resources used (paid). When the earned amount exceeds the paid amount, the difference is reduction in the reconciliation (-); when the paid amount exceeds the earned amount the difference is an addition to the reconciliation (+).	3,942.29
Governmental funds report School District pension contributions as expenditures. However in the statement of activities, the cost of pension benefits earned is reported as pension expense. This is the amount by which pension benefits earned exceeded the School District's pension contributions in the current period.	(9,702.19)
Change in Net Position of Governmental Activities	<u><u>(55,423.00)</u></u>
The accompanying Notes to Financial Statements are an integral part of this statement.	<u><u>\$ 110,594.01</u></u>

TOWNSHIP OF DELANCO SCHOOL DISTRICT
Proprietary Funds
Statement of Net Position
June 30, 2016

	Business-Type Activities Enterprise Funds			Governmental Activities - Internal Service Fund
	Food Service	Ex Care Program	Total	Substitute Calling
ASSETS:				
Current Assets:				
Cash and Cash Equivalents	\$ 5,327.21	\$ 22,170.42	\$ 27,497.63	\$ 637.87
Accounts Receivable:				
State	77.94		77.94	
Federal	3,845.98		3,845.98	
Other	43.10	2,214.82	2,257.92	
Inventories	3,430.35		3,430.35	
Total Current Assets	12,724.58	24,385.24	37,109.82	637.87
Noncurrent Assets:				
Equipment	178,961.00		178,961.00	
Less Accumulated Depreciation	(117,440.61)		(117,440.61)	
Total Capital Assets (Net of Accumulated Depreciation)	61,520.39	-	61,520.39	-
Total Noncurrent Assets	61,520.39	-	61,520.39	-
Total Assets	74,244.97	24,385.24	98,630.21	637.87
LIABILITIES:				
Current Liabilities:				
Accounts Payable	526.96		526.96	
Unearned Revenue	1,552.49	1,074.17	2,626.66	637.87
Total Liabilities	2,079.45	1,074.17	3,153.62	637.87
NET POSITION:				
Net Investment in Capital Assets	61,520.39		61,520.39	
Unrestricted	10,645.13	23,311.07	33,956.20	
Total Net Position	\$ 72,165.52	\$ 23,311.07	\$ 95,476.59	\$ -

The accompanying Notes to Financial Statements are an integral part of this statement.

TOWNSHIP OF DELANCO SCHOOL DISTRICT
Proprietary Funds
Statement of Revenues, Expenses and Changes in Fund Net Position
For the Fiscal Year Ended June 30, 2016

	Business-Type Activities Enterprise Funds			Governmental Activities - Internal Service Fund
	Food Service	Ex Care Program	Total	Substitute Calling
OPERATING REVENUES:				
Charges for Services:				
Daily Sales - Reimbursable Programs:				
School Lunch Program	\$ 46,889.80	\$ -	\$ 46,889.80	\$ -
School Breakfast Program	2,441.60		2,441.60	
Daily Sales - Non-Reimbursable Programs	20,416.35		20,416.35	
Community Service Activities		97,920.97	97,920.97	
Substitute Calling Fees from Other LEAs Within the State				9,085.23
Total Operating Revenues	69,747.75	97,920.97	167,668.72	9,085.23
OPERATING EXPENSES:				
Direct Expenses	4,916.96		4,916.96	
Cost of Sales - Reimbursable Programs	50,360.02		50,360.02	
Cost of Sales - Non-Reimbursable Programs	7,648.00		7,648.00	
Management Fees	13,259.82		13,259.82	
Salaries	77,295.81	46,633.14	123,928.95	7,659.37
Benefits		3,567.47	3,567.47	670.87
Purchased Professional Services		2,500.00	2,500.00	655.40
Supplies and Materials	3,579.46	4,292.64	7,872.10	115.24
Rent		53,000.00	53,000.00	
Depreciation	10,253.40		10,253.40	
Total Operating Expenses	167,313.47	109,993.25	277,306.72	9,100.88
Operating Income (Loss)	(97,565.72)	(12,072.28)	(109,638.00)	(15.65)
NONOPERATING REVENUES (EXPENSES):				
State Sources:				
State School Lunch Program	1,730.25		1,730.25	
Federal Sources:				
National School Lunch Program	65,576.13		65,576.13	
National School PB Lunch Program	2,133.42		2,133.42	
National School Breakfast Program	11,151.64		11,151.64	
Food Distribution Program	13,924.26		13,924.26	
Interest Revenue	105.40	157.45	262.85	15.65
Total Nonoperating Revenues (Expenses)	94,621.10	157.45	94,778.55	15.65
Change in Net Position	(2,944.62)	(11,914.83)	(14,859.45)	-
Net Position -- July 1	75,110.14	35,225.90	110,336.04	-
Net Position -- June 30	\$ 72,165.52	\$ 23,311.07	\$ 95,476.59	\$ -

The accompanying Notes to Financial Statements are an integral part of this statement.

TOWNSHIP OF DELANCO SCHOOL DISTRICT
Proprietary Funds
Statement of Cash Flows
For the Fiscal Year Ended June 30, 2016

	Business-Type Activities Enterprise Funds			Governmental Activities - Internal Service Fund
	Food Service	Ex Care Program	Total	Substitute Calling
CASH FLOWS FROM OPERATING ACTIVITIES:				
Receipts from Customers	\$ 71,257.14	\$ 97,340.57	\$ 168,597.71	\$ 9,170.00
Payments to Management Company	(147,932.40)		(147,932.40)	
Payments to Employees		(46,633.14)	(46,633.14)	(7,659.37)
Payments for Employee Benefits		(3,567.47)	(3,567.47)	(670.87)
Payments for Professional Services		(2,500.00)	(2,500.00)	(655.40)
Payments for Rent		(53,000.00)	(53,000.00)	
Payments to Suppliers	(14,547.80)	(4,292.64)	(18,840.44)	(115.24)
Net Cash Provided by (Used for) Operating Activities	<u>(91,223.06)</u>	<u>(12,652.68)</u>	<u>(103,875.74)</u>	<u>69.12</u>
CASH FLOWS FROM NON-CAPITAL FINANCING ACTIVITIES:				
State Sources	1,749.51		1,749.51	
Federal Sources	93,600.44		93,600.44	
Net Cash Provided by (Used for) Non-Capital Financing Activities	<u>95,349.95</u>	<u>-</u>	<u>95,349.95</u>	<u>-</u>
CASH FLOWS FROM INVESTING ACTIVITIES:				
Interest Revenue	105.40	157.45	262.85	15.65
Net Increase (Decrease) in Cash and Cash Equivalents	4,232.29	(12,495.23)	(8,262.94)	84.77
Cash and Cash Equivalents -- July 1	1,094.92	34,665.65	35,760.57	553.10
Cash and Cash Equivalents -- June 30	<u>\$ 5,327.21</u>	<u>\$ 22,170.42</u>	<u>\$ 27,497.63</u>	<u>\$ 637.87</u>
Reconciliation of Operating Income (Loss) to Net Cash Provided (Used) by Operating Activities:				
Operating Income (Loss)	\$ (97,565.72)	\$ (12,072.28)	\$ (109,638.00)	\$ (15.65)
Adjustments to Reconcile Operating Income (Loss) to Net Cash Provided by (Used for) Operating Activities:				
Depreciation and Net Amortization	10,253.40		10,253.40	
(Increase) Decrease in Accounts Receivable	(43.10)	(1,161.57)	(1,204.67)	
(Increase) Decrease in Inventories	(896.56)		(896.56)	
Increase (Decrease) in Accounts Payable	(4,523.57)		(4,523.57)	
Increase (Decrease) in Unearned Revenue	1,552.49	581.17	2,133.66	84.77
Total Adjustments	<u>6,342.66</u>	<u>(580.40)</u>	<u>5,762.26</u>	<u>84.77</u>
Net Cash Provided by (Used for) Operating Activities	<u>\$ (91,223.06)</u>	<u>\$ (12,652.68)</u>	<u>\$ (103,875.74)</u>	<u>\$ 69.12</u>

The accompanying Notes to Financial Statements are an integral part of this statement.

TOWNSHIP OF DELANCO SCHOOL DISTRICT
 Fiduciary Funds
 Statement of Fiduciary Net Position
 June 30, 2016

	Private-Purpose Trust Fund	Agency Funds	
	Scholarship Fund	Student Activity	Payroll
ASSETS:			
Cash and Cash Equivalents	\$ 2,373.91	\$ 20,164.77	\$ 4,475.16
Total Assets	<u>2,373.91</u>	<u>\$ 20,164.77</u>	<u>\$ 4,475.16</u>
LIABILITIES:			
Interfund Accounts Payable:			
Due General Fund		\$ -	\$ 49.37
Payroll Deductions Payable			4,425.79
Payable to Student Groups		<u>20,164.77</u>	
Total Liabilities	<u>-</u>	<u>\$ 20,164.77</u>	<u>\$ 4,475.16</u>
NET POSITION:			
Held in Trust for Other Purposes	<u>\$ 2,373.91</u>		

The accompanying Notes to Financial Statements are an integral part of this statement.

TOWNSHIP OF DELANCO SCHOOL DISTRICT
 Fiduciary Funds
 Statement of Changes in Fiduciary Net Position
 For the Fiscal Year Ended June 30, 2016

	Private-Purpose Trust Fund	
	Scholarship Fund	
ADDITIONS:		
Investment Earnings:		
Interest	\$	2.39
DEDUCTIONS:		
Scholarship Awards		50.00
Change in Net Position		(47.61)
Net Position -- July 1		2,421.52
Net Position -- June 30	\$	2,373.91

The accompanying Notes to Financial Statements are an integral part of this statement.

TOWNSHIP OF DELANCO SCHOOL DISTRICT
Notes to Financial Statements
For the Fiscal Year Ended June 30, 2016

Note 1: SUMMARY OF SIGNIFICANT ACCOUNTING POLICIES

The financial statements of the Township of Delanco School District (the "School District") have been prepared to conform with accounting principles generally accepted in the United States of America ("GAAP") as applied to governmental units. The Governmental Accounting Standards Board ("GASB") is the accepted standard setting body for establishing governmental accounting and financial reporting principles. The following is a summary of the more significant of these policies.

Description of the Financial Reporting Entity

The School District is a Type II district located in the County of Burlington, State of New Jersey. As a Type II district, the School District functions independently through a Board of Education (the "Board"). The Board is comprised of nine members elected to three-year terms. These terms are staggered so that three member's terms expire each year. The Superintendent is appointed by the Board to act as executive officer of the School District. The purpose of the School District is to educate students in grades K through 8 at its two schools. The School District has an approximate enrollment at June 30, 2016 of 392.

The primary criterion for including activities within the School District's reporting entity, as set forth in Section 2100 of the Governmental Accounting Standards Board *Codification of Governmental Accounting and Financial Reporting Standards*, is the degree of oversight responsibility maintained by the School District. Oversight responsibility includes financial interdependency, selection of governing authority, designation of management, ability to significantly influence operations and accountability for fiscal matters. The combined financial statements include all funds of the School District over which the Board exercises operating control.

Component Units

In evaluating how to define the School District for financial reporting purposes, management has considered all potential component units. The decision to include any potential component units in the financial reporting entity was made by applying the criteria set forth in GASB Statements No. 14, *The Financial Reporting Entity*, as amended by GASB Statement No. 39, *Determining Whether Certain Organizations are Component Units*, and GASB Statement No. 61, *The Financial Reporting Entity: Omnibus - an amendment of GASB Statements No. 14 and No. 34*. Blended component units, although legally separate entities, are in-substance part of the government's operations. Each discretely presented component unit is reported in a separate column in the government-wide financial statements to emphasize that it is legally separate from the government.

The basic-but not the only-criterion for including a potential component unit within the reporting entity is the governing body's ability to exercise oversight responsibility. The most significant manifestation of this ability is financial interdependency. Other manifestations of the ability to exercise oversight responsibility include, but are not limited to, the selection of governing authority, the designation of management, the ability to significantly influence operations, and accountability for fiscal matters. A second criterion used in evaluating potential component units is the scope of public service. Application of this criterion involves considering whether the activity benefits the government and / or its citizens.

A third criterion used to evaluate potential component units for inclusion or exclusion from the reporting entity is the existence of special financing relationships, regardless of whether the government is able to exercise oversight responsibilities. Finally, the nature and significance of a potential component unit to the primary government could warrant its inclusion within the reporting entity.

Based upon the application of these criteria, the School District has no component units, and is not a component unit of another governmental agency.

Note 1: SUMMARY OF SIGNIFICANT ACCOUNTING POLICIES (CONT'D)**Government-wide and Fund Financial Statements**

The School District's basic financial statements consist of government-wide statements, and fund financial statements which provide a more detailed level of financial information.

The government-wide financial statements (i.e., the statement of net position and the statement of activities) report information on all of the nonfiduciary activities of the primary government. For the most part, the effect of interfund activity has been removed from these statements. Governmental activities, which normally are supported by property taxes and intergovernmental revenues, are reported separately from business-type activities, which rely to a significant extent on fees and charges for support.

The statement of activities demonstrates the degree to which the direct expenses of a given function or segment is offset by program revenues. Direct expenses are those that are specifically associated with a service, program, or department and, therefore, clearly identifiable to a particular function. It is the policy of the School District to not allocate indirect expenses to functions in the statement of activities. Program revenues include (1) charges to customers or applicants who purchase, use, or directly benefit from goods, services, or privileges provided by a given function or segment and (2) grants and contributions that are restricted to meeting the operational or capital requirements of a particular function or segment. Property taxes and other items not properly included among program revenues are reported instead as general revenues.

In regards to the fund financial statements, the School District segregates transactions related to certain functions or activities in separate funds in order to aid financial management and to demonstrate legal compliance. A fund is defined as a fiscal and accounting entity with a self-balancing set of accounts. Fund financial statements report detailed information about the School District. The focus of governmental fund financial statements is on major funds rather than reporting funds by type. Each major fund is presented in a single column. Internal service funds are aggregated and presented in a single column on the face of the proprietary fund statements. Fiduciary funds are reported by fund type.

Measurement Focus, Basis of Accounting and Financial Statement Presentation

The government-wide financial statements are reported using the economic resources measurement focus and the accrual basis of accounting, as are the proprietary fund and fiduciary fund financial statements. Revenues are recorded when earned and expenses are recorded when a liability is incurred, regardless of the timing of related cash flows. Grants and similar items are recognized as revenue as soon as all eligibility requirements imposed by the provider have been met. Property taxes are recognized as revenues in the year for which they are levied. The Burlington County Board of Taxation is responsible for the assessment of properties, and the respective municipal tax collector is responsible for the collection of property taxes. Assessments are certified and property taxes are levied on January 1. Property tax payments are due February 1, May 1, August 1 and November 1. Unpaid property taxes are considered delinquent the following January 1 and are then subject to municipal lien. In accordance with New Jersey State Statute, the School District is entitled to receive moneys under an established payment schedule, and any unpaid amount is considered as an accounts receivable. The governing body of each municipality is required to pay over to the School District, within forty (40) days after the beginning of the school year, twenty percent (20%) of the moneys from school tax due. Thereafter, but prior to the last day of the school year, the municipality must pay the balance of moneys from school tax due for school purposes in such amounts as requested, with certain limitations, from time to time by the School District, within thirty days after each request.

Note 1: SUMMARY OF SIGNIFICANT ACCOUNTING POLICIES (CONT'D)**Measurement Focus, Basis of Accounting and Financial Statement Presentation (Cont'd)**

Governmental fund financial statements are reported using the current financial resources measurement focus and the modified accrual basis of accounting. Revenues are recorded when they are deemed both available and measurable. Available means when revenues are collectible within the current period or soon enough thereafter to pay liabilities of the current period. For this purpose, the School District considers revenues to be available if they are collected within sixty (60) days of the end of the current fiscal year. Measurable means that the amount of revenue can be determined. Expenditures generally are recorded when a liability is incurred, as under accrual accounting. However, debt service expenditures, as well as expenditures related to compensated absences and claims and judgments, are recorded only when payment is due.

Property taxes, tuition, reimbursable-type grants, and interest associated with the current fiscal year are all considered to be susceptible to accrual and so have been recognized as revenues of the current fiscal year. All other revenue items are considered to be measurable and available only when cash is received by the School District.

The School District reports the following major governmental funds:

General Fund - The general fund is the primary operating fund of the School District. It is used to account for all financial resources except those required to be accounted for in another fund. Included are certain expenditures for vehicles and movable instructional or non-instructional equipment classified in the capital outlay sub-fund.

As required by the New Jersey State Department of Education, the School District includes budgeted capital outlay in this fund. Accounting principles generally accepted in the United States of America, as they pertain to governmental entities, state that general fund resources may be used to directly finance capital outlays for long-lived improvements as long as the resources in such cases are derived exclusively from unrestricted revenues.

Resources for budgeted capital outlay purposes are normally derived from State of New Jersey aid, ad valorem tax revenues, and appropriated fund balance. Expenditures are those which result in the acquisition of or additions to capital assets for land, existing buildings, improvements of grounds, construction of buildings, additions to, or remodeling of buildings, and the purchase of built-in equipment.

Special Revenue Fund - The special revenue fund is used to account for and report the proceeds of specific revenue sources that are restricted or committed to expenditures for specified purposes other than debt service or capital projects.

Capital Projects Fund - The capital projects fund is used to account for and report financial resources that are restricted, committed, or assigned to expenditures for capital outlays, including the acquisition or construction of capital facilities and other capital assets, other than those financed by proprietary funds.

Debt Service Fund - The debt service fund is used to account for and report financial resources that are restricted, committed, or assigned to expenditures for principal and interest.

Proprietary funds are used to account for the School District's ongoing organizations and activities, which are operated and financed in a manner similar to those found in the private sector. The measurement focus is upon the determination of net income. Proprietary funds distinguish operating revenues and expenses from nonoperating items. Operating revenues and expenses generally result from providing services and producing and delivering goods in connection with a proprietary fund's principal ongoing operations. Operating expenses for internal service funds include salaries, benefits, administrative expenses, and claims paid. All items not meeting this definition are reported as nonoperating revenues and expenses.

Note 1: SUMMARY OF SIGNIFICANT ACCOUNTING POLICIES (CONT'D)**Measurement Focus, Basis of Accounting and Financial Statement Presentation (Cont'd)**

The School District reports the following major proprietary funds:

Food Service Fund - This fund accounts for the financial transactions related to the food service operations of the School District.

Ex Care Fund - This fund accounts for the financial activity related to providing day care services for School District students before and after school.

Additionally, the School District reports the following fund types:

Internal Service Funds

Internal service funds are used to account for the financing of goods and services provided by one department to another on a cost reimbursement basis. The School District maintains one internal service fund for substitute caller services provided by Delanco Township School District for use by various other boards of education as well as by the Delanco Township School District itself.

Fiduciary funds are used to account for assets held by the School District on behalf of outside related organizations or on behalf of other funds within the School District. The fiduciary fund category is split into four classifications: pension trust funds, investment trust funds, private-purpose trust funds, and agency funds.

The School District maintains the following fiduciary funds:

Agency Funds - Agency funds are used to account for assets held by the School District in a trustee capacity or as an agent for individuals, private organizations, other governments, and / or other funds (i.e., payroll and student activities). The School District retains no equity interest in these funds. Agency funds are custodial in nature (assets equal liabilities) and do not involve measurement of results of operations. The School District maintains the following agency funds: student activity fund and payroll fund.

Private-Purpose Trust Funds - Private-purpose trust funds are used to account for the principal and income for all other trust arrangements that benefit individuals, private organizations, or other governments. The School District maintains the following private-purpose trust fund:

Scholarship Fund - Revenues consist of donations and interest income. Expenditures represent scholarships for future teachers, which are awarded in accordance with the trust requirements.

As a general rule the effect of interfund activity has been eliminated from the government-wide financial statements.

Amounts reported as program revenues include (1) charges to customers or applicants for goods, services, or privileges provided, (2) operating grants and contributions, and (3) capital grants and contributions. Internally dedicated resources are reported as general revenues rather than as program revenues. Likewise, general revenues include all property taxes.

Note 1: SUMMARY OF SIGNIFICANT ACCOUNTING POLICIES (CONT'D)**Budgets / Budgetary Control**

Annual appropriated budgets are prepared in the spring of each fiscal year for the general, special revenue, and debt service funds, and are submitted to the county office of education. In accordance with P.L. 2011, c. 202, the School District passed a resolution to move the school board election to the first Tuesday after the first Monday in November, starting in November of 2012, to be held simultaneously with the general election. As a result, a vote is not required on the School District's general fund tax levy for the budget year, other than the general fund tax levy required to support a proposal for additional funds, if any. Budgets are prepared using the modified accrual basis of accounting. The legal level of budgetary control is established at line item accounts within each fund. Line item accounts are defined as the lowest (most specific) level of detail as established pursuant to the minimum chart of accounts referenced in N.J.A.C. 6A:23A-16.2(f)1. Transfers of appropriations may be made by school board resolution at any time during the fiscal year in accordance with N.J.A.C. 6A:23A-13.3.

Formal budgetary integration into the accounting system is employed as a management control device during the year. For governmental funds there are no substantial differences between the budgetary basis of accounting and generally accepted accounting principles, with the exception of the legally mandated revenue recognition of the one or more June state aid payments for budgetary purposes only, and the special revenue fund. N.J.S.A. 18A:22-44.2 provides that in the event a state school aid payment is not made until the following school budget year, school districts must record the delayed one or more June state aid payments as revenue, for budget purposes only, in the current school budget year. The bill provides legal authority for school districts to recognize this revenue in the current budget year. Encumbrance accounting is also employed as an extension of formal budgetary integration in the governmental fund types. Unencumbered appropriations lapse at fiscal year-end.

The accounting records of the special revenue fund are maintained on the budgetary basis. The budgetary basis differs from GAAP in that the budgetary basis recognizes encumbrances as expenditures and also recognizes the related revenues, whereas the GAAP basis does not. Sufficient supplemental records are maintained to allow for the presentation of GAAP basis financial reports.

The budget, as detailed on exhibit C-1, exhibit C-2 and exhibit I-3 includes all amendments to the adopted budget, if any.

Exhibit C-3 presents a reconciliation of the general fund revenues and special revenue fund revenues and expenditures from the budgetary basis of accounting, as presented in the general fund budgetary comparison schedule and the special revenue fund budgetary comparison schedule, to the GAAP basis of accounting as presented in the statement of revenues, expenditures and changes in fund balances - governmental funds. Note that the School District does not report encumbrances outstanding at fiscal year-end as expenditures in the general fund since the general fund budget follows the modified accrual basis of accounting, with the exception of the aforementioned revenue recognition policy for the one or more June state aid payments.

Encumbrances

Encumbrance accounting, under which purchase orders, contracts, and other commitments for the expenditure of funds are recorded to assign a portion of the applicable appropriation, is utilized for budgetary control purposes. Encumbrances are a component of fund balance at fiscal year-end as they do not constitute expenditures or liabilities, but rather commitments related to unperformed contracts for goods and services. Open encumbrances in the governmental funds, other than the special revenue fund, which have not been previously restricted, committed, or assigned, should be included within committed or assigned fund balance, as appropriate.

Open encumbrances in the special revenue fund, however, for which the School District has received advances of grant awards, are reflected on the balance sheet as unearned revenues at fiscal year-end.

Note 1: SUMMARY OF SIGNIFICANT ACCOUNTING POLICIES (CONT'D)**Encumbrances (Cont'd)**

The encumbered appropriation authority carries over into the next fiscal year. An entry will be made at the beginning of the next fiscal year to increase the appropriation reflected in the certified budget by the outstanding encumbrance amount as of the current fiscal year end.

Cash, Cash Equivalents and Investments

Cash and cash equivalents, for all funds, include petty cash, change funds, cash in banks and all highly liquid investments with a maturity of three months or less at the time of purchase and are stated at cost plus accrued interest. Such is the definition of cash and cash equivalents used in the statement of cash flows for the proprietary funds. U.S. treasury and agency obligations and certificates of deposit with maturities of one year or less when purchased are stated at cost. All other investments are stated at fair value.

New Jersey school districts are limited as to the types of investments and types of financial institutions they may invest in. N.J.S.A. 18A:20-37 provides a list of permissible investments that may be purchased by New Jersey school districts.

N.J.S.A. 17:9-41 et seq. establishes the requirements for the security of deposits of governmental units. The statute requires that no governmental unit shall deposit public funds in a public depository unless such funds are secured in accordance with the Governmental Unit Deposit Protection Act ("GUDPA"), a multiple financial institutional collateral pool, which was enacted in 1970 to protect governmental units from a loss of funds on deposit with a failed banking institution in New Jersey. Public depositories include State or federally chartered banks, savings banks or associations located in or having a branch office in the State of New Jersey, the deposits of which are federally insured. All public depositories must pledge collateral, having a market value at least equal to five percent of the average daily balance of collected public funds, to secure the deposits of governmental units. If a public depository fails, the collateral it has pledged, plus the collateral of all other public depositories, is available to pay the amount of their deposits to the governmental units.

Inventories

Inventories are valued at cost, which approximates market. The costs are determined on a first-in, first-out method.

The cost of inventories in the governmental fund financial statements is recorded as expenditures when purchased rather than when consumed.

Inventories recorded on the government-wide financial statements and in the proprietary fund types are recorded as expenses when consumed rather than when purchased.

Tuition Receivable

Tuition charges were established by the School District based on estimated costs. The charges are subject to adjustment when the final costs are determined.

Prepaid Expenses

Prepaid expenses recorded on the government-wide financial statements and in the proprietary fund types represent payments made to vendors for services that will benefit periods beyond June 30, 2016.

Note 1: SUMMARY OF SIGNIFICANT ACCOUNTING POLICIES (CONT'D)**Prepaid Expenses (Cont'd)**

In the governmental fund financial statements, however, payments for prepaid items are fully recognized as expenditures in the fiscal year of payment. No asset for the prepayment is created, and no expenditure allocation to future accounting periods is required (*non-allocation method*). This is consistent with the basic governmental concept that only expendable financial resources are reported by a specific fund.

Short-Term Interfund Receivables / Payables

Short-term interfund receivables / payables (internal balances) represent amounts that are owed, other than charges for goods or services rendered to / from a particular fund within the School District, and that are due within one year. Such balances are eliminated in the statement of net position to minimize the grossing up of internal balances, thus leaving a net amount due between the governmental and business-type activities that are eliminated in the total government column. Balances with fiduciary activities are not considered to be internal balances; therefore, such balances appear on the statement of net position as accounts receivable.

Capital Assets

Capital assets represent the cumulative amount of capital assets owned by the School District. Purchased capital assets are recorded as expenditures in the governmental fund financial statements and are capitalized at cost on the government-wide statement of net position and proprietary fund statement of net position. In the case of gifts or contributions, such capital assets are recorded at acquisition value at the time of the transaction.

The School District's capitalization threshold is \$2,000.00. Other costs incurred for repairs and maintenance is expensed as incurred. All reported capital assets, except land and construction in progress, are depreciated. Depreciation is computed using the straight-line method over the following estimated useful lives:

<u>Description</u>	<u>Estimated Lives</u>
Equipment	3 - 25 Years
Buildings and Improvements	20 - 40 Years
Land Improvements	15 - 20 Years

The School District does not possess any infrastructure assets.

Deferred Outflows and Deferred Inflows of Resources

The statement of net position reports separate sections for deferred outflows of resources and deferred inflows of resources. Deferred outflows of resources, reported after total assets, represents a reduction of net position that applies to a future period(s) and will be recognized as an outflow of resources (expense) at that time. Deferred inflows of resources, reported after total liabilities, represents an acquisition of net position that applies to a future period(s) and will be recognized as an inflow of resources (revenue) at that time.

Transactions are classified as deferred outflows of resources and deferred inflows of resources only when specifically prescribed by the Governmental Accounting Standards Board (GASB) standards. The School District is required to report the following as deferred outflows of resources and deferred inflows of resources:

Note 1: SUMMARY OF SIGNIFICANT ACCOUNTING POLICIES (CONT'D)**Deferred Outflows and Deferred Inflows of Resources (Cont'd)**

Defined Benefit Pension Plans - The difference between expected (actuarial) and actual experience, changes in actuarial assumptions, net difference between projected (actuarial) and actual earnings on pension plan investments, changes in the School District's proportion of expenses and liabilities to the pension as a whole, differences between the School District's pension contribution and its proportionate share of contributions, and the School District's pension contributions subsequent to the pension valuation measurement date.

In addition, the School District reports the following as deferred outflows of resources:

Loss on Refunding of Debt - The loss on refunding arose from the issuance of refunding bonds, which is amortized in a systematic and rational manner over the duration of the related debt as a component of interest expense.

Tuition Payable

Tuition charges for the fiscal years ended June 30, 2016 and 2015 were based on rates established by the receiving district. These rates are subject to change when the actual costs have been determined.

Unearned Revenue

Unearned revenue arises when assets are recognized before revenue recognition criteria have been satisfied and is recorded as a liability until the revenue is both measurable and the School District is eligible to realize the revenue.

Accrued Salaries and Wages

Certain School District employees who provide services to the School District over the ten-month academic year have the option to have their salaries evenly disbursed during the entire twelve-month year. New Jersey statutes require that these earned but undisbursed amounts be retained in a separate bank account.

Compensated Absences

Compensated absences are payments to employees for accumulated time such as paid vacation, paid holidays, sick pay, and sabbatical leave. A liability for compensated absences that is attributable to services already rendered, and that are not contingent on a specific event that is outside the control of the School District and its employees, is accrued as the employees earn the rights to the benefits. Compensated absences that relate to future services, or that are contingent on a specific event that is outside the control of the School District and its employees, are accounted for in the period in which such services are rendered or in which such events take place.

The School District uses the vesting method to calculate the compensated absences amount. The entire compensated absence liability, including the employer's share of applicable taxes, is reported on the government-wide financial statements. The portion related to employees in the proprietary funds is recorded at the fund level. The current portion is the amount estimated to be used in the following fiscal year. Expenditures are recognized in the governmental funds as payments come due each period, for example, as a result of employee resignations and retirements. Compensated absences not recorded at the fund level represent a reconciling item between the fund level and government-wide presentations.

Note 1: SUMMARY OF SIGNIFICANT ACCOUNTING POLICIES (CONT'D)**Accrued Liabilities and Long-Term Obligations**

All payables, accrued liabilities, and long-term obligations are reported in the government-wide financial statements, and all payables, accrued liabilities, and long-term obligations payable from proprietary funds are reported on the proprietary fund financial statements. In general, governmental fund payables and accrued liabilities that, once incurred, are paid in a timely manner, and in full from current financial resources, are reported as obligations of the funds. However, claims and judgments, compensated absences, special termination benefits, and contractually required pension contributions that will be paid from governmental funds, are reported as a liability in the fund financial statements only to the extent that they are normally expected to be paid with expendable available financial resources. Bonds are recognized as a liability on the governmental fund financial statements when due.

Pensions

For purposes of measuring the net pension liability, deferred outflows of resources and deferred inflows of resources related to pensions, and pension expense, information about the fiduciary net position of the Teachers' Pension and Annuity Fund ("TPAF") and the Public Employees' Retirement System ("PERS"), and additions to/deductions from TPAF's and PERS's fiduciary net position have been determined on the same basis as they are reported by the plans. For this purpose, benefit payments (including refunds of employee contributions) are recognized when due and payable in accordance with the benefit terms. Investments are reported at fair value.

Bond Discounts / Premiums

Bond discounts / premiums arising from the issuance of long-term debt (bonds) are amortized over the life of the bonds, in systematic and rational method, as a component of interest expense. Bond discounts / premiums are presented as an adjustment of the face amount of the bonds on the government-wide statement of net position and on the proprietary fund statement of net position.

Net Position

Net position represents the difference between the summation of assets and deferred outflows of resources, and the summation of liabilities and deferred inflows of resources. Net position is classified into the following three components:

Net Investment in Capital Assets - This component represents capital assets, net of accumulated depreciation, net of outstanding balances of borrowings used for the acquisition, construction, or improvement of those assets.

Restricted - Net position is reported as restricted when there are limitations imposed on their use either through the enabling legislation adopted by the School District or through external restrictions imposed by creditors, grantors or laws or regulations of other governments.

Unrestricted - Net position is reported as unrestricted when it does not meet the criteria of the other two components of net position.

The School District applies restricted resources when an expense is incurred for purposes for which both restricted and unrestricted net position is available.

Note 1: SUMMARY OF SIGNIFICANT ACCOUNTING POLICIES (CONT'D)**Fund Balance**

The School District reports fund balance in classifications that comprise a hierarchy based primarily on the extent to which the School District is bound to honor constraints on the specific purposes for which amounts in those funds can be spent. The School District's classifications, and policies for determining such classifications, are as follows:

Nonspendable - The nonspendable fund balance classification includes amounts that cannot be spent because they are either not in spendable form or are legally or contractually required to be maintained intact. The "not in spendable form" criterion includes items that are not expected to be converted to cash, such as inventories and prepaid amounts.

Restricted - The restricted fund balance classification includes amounts that are restricted to specific purposes. Such restrictions, or constraints, are placed on the use of resources either by being (1) externally imposed by creditors, grantors, contributors, or laws or regulations of other governments; or (2) imposed by law through constitutional provisions or enabling legislation.

Committed - The committed fund balance classification includes amounts that can only be used for specific purposes pursuant to constraints imposed by formal action of the School District's highest level of decision-making authority, which, for the School District, is the Board of Education. Such formal action consists of an affirmative vote by the Board of Education, memorialized by the adoption of a resolution. Once committed, amounts cannot be used for any other purpose unless the Board of Education removes, or changes, the specified use by taking the same type of action (resolution) it employed to previously commit those amounts.

Assigned - The assigned fund balance classification includes amounts that are constrained by the School District's *intent* to be used for specific purposes, but are neither restricted nor committed. *Intent* is expressed by either the Board of Education or by the business administrator, to which the Board of Education has delegated the authority to assign amounts to be used for specific purposes. Such authority of the business administrator is established by way of a formal job description for the position and standard operating procedures, approved by the Board of Education.

Unassigned - The unassigned fund balance classification is the residual classification for the general fund. This classification represents fund balance that has not been assigned to other funds and that has not been restricted, committed, or assigned to specific purposes within the general fund. The general fund is the only fund that reports a positive unassigned fund balance amount. In other governmental funds, if expenditures incurred for specific purposes exceed the amounts restricted, committed, or assigned to those purposes, it may be necessary to report a negative unassigned fund balance.

When expenditures are incurred for purposes for which both restricted and unrestricted fund balances are available, it is the policy of the School District to spend restricted fund balances first. Moreover, when expenditures are incurred for purposes for which amounts in any of the unrestricted fund balance classifications can be used, it is the policy of the School District to spend fund balances, if appropriate, in the following order: committed, assigned, then unassigned.

Note 1: SUMMARY OF SIGNIFICANT ACCOUNTING POLICIES (CONT'D)**Interfund Activity**

Transfers between governmental and business-type activities on the government-wide statements are reported in the same manner as general revenues. Exchange transactions between funds are reported as revenues in the seller funds and as expenditures / expenses in the purchaser funds. Flows of cash or goods from one fund to another without a requirement for repayment are reported as interfund transfers. Interfund transfers are reported as other financing sources / uses in governmental funds and after non-operating revenues / expenses in proprietary funds. Reimbursements from funds responsible for particular expenditures / expenses to the funds that initially paid for them are not presented on the financial statements.

Accounting Estimates

The preparation of financial statements in conformity with accounting principles generally accepted in the United States of America requires management to make estimates and assumptions that affect the amounts reported in the financial statements and accompanying notes. Actual results may differ from those estimates.

Impact of Recently Issued Accounting Principles**Recently Issued and Adopted Accounting Pronouncements**

The following GASB Statements became effective for the fiscal year ended June 30, 2016:

Statement No. 72, *Fair Value Measurement and Application*. This Statement addresses accounting and financial reporting issues related to fair value measurements. The definition of fair value is the price that would be received to sell an asset or paid to transfer a liability in an orderly transaction between market participants at the measurement date. This Statement provides guidance for determining a fair value measurement for financial reporting purposes. This Statement also provides guidance for applying fair value to certain investments and disclosures related to all fair value measurements. The adoption of this Statement had no impact on the basic financial statements of the School District.

Statement No. 73, *Accounting and Financial Reporting for Pensions and Related Assets That Are Not within the Scope of GASB Statement 68, and Amendments to Certain Provisions of GASB Statements 67 and 68*. The objective of this Statement is to improve the usefulness of information about pensions included in the general purpose external financial reports of state and local governments for making decisions and assessing accountability. The adoption of this Statement had no impact on the basic financial statements of the School District.

Statement No. 76, *The Hierarchy of Generally Accepted Accounting Principles for State and Local Governments*. The objective of this Statement is to identify, in the context of the current governmental financial reporting environment, the hierarchy of generally accepted accounting principles (GAAP). The "GAAP hierarchy" consists of the sources of accounting principles used to prepare financial statements of state and local governmental entities in conformity with GAAP and the framework for selecting those principles. This Statement reduces the GAAP hierarchy to two categories of authoritative GAAP and addresses the use of authoritative and nonauthoritative literature in the event that the accounting treatment for a transaction or other event is not specified within a source of authoritative GAAP. The adoption of this Statement had no impact on the basic financial statements of the School District.

Statement No. 79, *Certain External Investment Pools and Pool Participants*. This Statement addresses accounting and financial reporting for certain external investment pools and pool participants. The adoption of this Statement had no impact on the basic financial statements of the School District.

Note 1: SUMMARY OF SIGNIFICANT ACCOUNTING POLICIES (CONT'D)**Impact of Recently Issued Accounting Principles (Cont'd)****Recently Issued Accounting Pronouncements**

The GASB has issued the following Statements during the fiscal year ended June 30, 2016 that will become effective in future fiscal years as shown below:

Statement No. 74, *Financial Reporting for Postemployment Benefit Plans Other Than Pension Plans*. The objective of this Statement is to improve the usefulness of information about postemployment benefits other than pensions (other postemployment benefits or OPEB) included in the general purpose external financial reports of state and local governmental OPEB plans for making decisions and assessing accountability. The Statement will become effective for the School District in fiscal year 2017. Management does not expect this Statement will have an impact on the basic financial statements of the School District.

Statement No. 75, *Accounting and Financial Reporting for Postemployment Benefits Other Than Pensions*. The primary objective of this Statement is to improve accounting and financial reporting by state and local governments for postemployment benefits other than pensions (other postemployment benefits or OPEB). It also improves information provided by state and local governmental employers about financial support for OPEB that is provided by other entities. The Statement will become effective for the School District in fiscal year 2018. Management has not yet determined the impact of this Statement on the basic financial statements of the School District.

Statement No. 77, *Tax Abatement Disclosures*. This Statement requires governments that enter into tax abatement agreements to disclose certain information about the agreements. The Statement will become effective for the School District in fiscal year 2017. Management does not expect this Statement will have an impact on the basic financial statements of the School District.

Statement No. 78, *Pensions Provided through Certain Multiple-Employer Defined Benefit Pension Plans*. The objective of this Statement is to address a practice issue regarding the scope and applicability of Statement No. 68, *Accounting and Financial Reporting for Pensions*. This issue is associated with pensions provided through certain multiple-employer defined benefit pension plans and to state or local governmental employers whose employees are provided with such pensions. The Statement will become effective for the School District in fiscal year 2017. Management does not expect this Statement will have an impact on the basic financial statements of the School District.

Statement No. 80, *Blending Requirements for Certain Component Units an amendment of GASB Statement No. 14*. This Statement amends the blending requirements for the financial statement presentation of component units of all state and local governments. The additional criterion requires blending of a component unit incorporated as a not-for-profit corporation in which the primary government is the sole corporate member. The additional criterion does not apply to component units included in the financial reporting entity pursuant to the provisions of Statement No. 39, *Determining Whether Certain Organizations Are Component Units*. The Statement will become effective for the School District in fiscal year 2017. Management does not expect this Statement will have an impact on the basic financial statements of the School District.

Statement No. 81, *Irrevocable Split-Interest Agreements*. The objective of this Statement is to improve accounting and financial reporting for irrevocable split-interest agreements by providing recognition and measurement guidance for situations in which a government is a beneficiary of the agreement. The Statement will become effective for the School District in fiscal year 2018. Management does not expect this Statement will have an impact on the basic financial statements of the School District.

Note 1: SUMMARY OF SIGNIFICANT ACCOUNTING POLICIES (CONT'D)

Impact of Recently Issued Accounting Principles (Cont'd)

Recently Issued Accounting Pronouncements (Cont'd)

Statement No. 82, *Pension Issues and amendment of GASB Statements No. 67, No. 68, and No. 73*. This Statement addresses issues regarding (1) the presentation of payroll-related measures in required supplementary information, (2) the selection of assumptions and the treatment of deviations from the guidance in an Actuarial Standard of Practice for financial reporting purposes, and (3) the classification of payments made by employers to satisfy employee (plan member) contribution requirements. The Statement will become effective for the School District in fiscal year 2017. Management does not expect this Statement will have a material impact on the basic financial statements of the School District.

Note 2: CASH AND CASH EQUIVALENTS

Custodial Credit Risk Related to Deposits - Custodial credit risk is the risk that, in the event of a bank failure, the School District's deposits might not be recovered. Although the School District does not have a formal policy regarding custodial credit risk, N.J.S.A. 17:9-41 et seq. requires that governmental units shall deposit public funds in public depositories protected from loss under the provisions of the Governmental Unit Deposit Protection Act (GUDPA). Under the Act, the first \$250,000.00 of governmental deposits in each insured depository is protected by the Federal Deposit Insurance Corporation (FDIC). Public funds owned by the School District in excess of FDIC insured amounts are protected by GUDPA. However, GUDPA does not protect intermingled agency funds such as salary withholdings, and student activity funds, or funds that may pass to the School District relative to the happening of a future condition. Such funds are classified as uninsured and uncollateralized.

As of June 30, 2016, the School District's bank balances of \$3,688,327.20 were exposed to custodial credit risk as follows:

Insured by FDIC and GUDPA	\$ 3,688,327.20
Uninsured and Uncollateralized	_____ -
Total	<u>\$ 3,688,327.20</u>

New Jersey Cash Management Fund - During the fiscal year, the School District participated in the New Jersey Cash Management Fund. The Fund is governed by regulations of the State Investment Council, who prescribe standards designed to insure the quality of investments in order to minimize risk to the Funds participants. Deposits with the New Jersey Cash Management Fund are not subject to custodial credit risk as defined above. At June 30, 2016, the School District's deposits with the New Jersey Cash Management Fund were \$800.70.

Note 3: CAPITAL RESERVE ACCOUNT

A capital reserve account was established by the School District by inclusion of \$100.00 on September 13, 2000 for the accumulation of funds for use as capital outlay expenditures in subsequent fiscal years. The capital reserve account is maintained in the general fund and its activity is included in the general fund annual budget.

Note 3: CAPITAL RESERVE ACCOUNT (CONT'D)

Funds placed in the capital reserve account are restricted to capital projects in the School District's approved Long Range Facilities Plan ("LRFP"). Upon submission of the LRFP to the Department, a school district may increase the balance in the capital reserve by appropriating funds in the annual general fund budget certified for taxes or by transfer by board resolution at fiscal year-end (June 1 to June 30) of any unanticipated revenue or unexpended line-item appropriation amounts, or both. A school district may also appropriate additional amounts when the express approval of the voters has been obtained by either a separate proposal at budget time or by a special question at one of the four special elections authorized pursuant to N.J.S.A. 19:60-2. Pursuant to N.J.A.C. 6A:23A-14.1(g), the balance in the account cannot at any time exceed the local support costs of uncompleted capital projects in its approved LRFP.

The activity of the capital reserve for the July 1, 2015 to June 30, 2016 fiscal year is as follows:

Beginning Balance, July 1, 2015	\$ 512,272.23
Increased by:	
Interest Earnings	<u>903.61</u>
Ending Balance, June 30, 2016	<u><u>\$ 513,175.84</u></u>

The June 30, 2016 LRFP balance of local support costs of uncompleted projects is \$1,585,000.00.

Note 4: ACCOUNTS RECEIVABLE

Accounts receivable at June 30, 2016 consisted of accounts (fees for services), intergovernmental awards / grants. All receivables are considered collectible in full due to the stable condition of federal and state programs, the current fiscal year guarantee of federal funds, and the regulated budgetary control of governmental entities in New Jersey.

Accounts receivable as of fiscal year end for the School District's individual major and fiduciary funds, in the aggregate, are as follows:

Description	Governmental Funds			Proprietary Funds			Total
	General Fund	Special Revenue Fund	Total Governmental Activities	Food Service Fund	Ex Care Fund	Total Business-Type Activities	
Federal Awards	\$ -	\$ 173,199.00	\$ 173,199.00	\$ 3,845.98	\$ -	\$ 3,845.98	\$ 177,044.98
State Awards	78,844.28		78,844.28	77.94		77.94	78,922.22
Fiduciary Fund	49.37		49.37				49.37
Other	1,589.60		1,589.60	43.10	2,214.82	2,257.92	3,847.52
	<u>\$ 80,483.25</u>	<u>\$ 173,199.00</u>	<u>\$ 253,682.25</u>	<u>\$ 3,967.02</u>	<u>\$ 2,214.82</u>	<u>\$ 6,181.84</u>	<u>\$ 259,864.09</u>

Note 5: INVENTORY

Inventory recorded at June 30, 2016 in business-type activities on the government-wide statement of net position, and on the food service enterprise fund statement of net position, consisted of the following:

Food	\$ 2,408.54
Supplies	<u>1,021.81</u>
	<u><u>\$ 3,430.35</u></u>

Note 6: CAPITAL ASSETS

Capital asset activity for the fiscal year ended June 30, 2016 is as follows:

	<u>Balance July 1, 2015</u>	<u>Increases</u>	<u>Decreases</u>	<u>Balance June 30, 2016</u>
Governmental Activities:				
Capital Assets, being Depreciated:				
Equipment	\$ 615,022.39	\$ 42,699.00	\$ (36,700.00)	\$ 621,021.39
Buildings and Improvements	17,228,266.16			17,228,266.16
Land Improvements	114,336.00			114,336.00
	<u>17,957,624.55</u>	<u>42,699.00</u>	<u>(36,700.00)</u>	<u>17,963,623.55</u>
Total Capital Assets, being Depreciated				
Less Accumulated Depreciation for:				
Equipment	(439,459.50)	(41,739.44)	36,700.00	(444,498.94)
Buildings and Improvements	(3,487,759.92)	(273,096.08)		(3,760,856.00)
Land Improvements	(105,710.25)	(2,464.50)		(108,174.75)
	<u>(4,032,929.67)</u>	<u>(317,300.02)</u>	<u>36,700.00</u>	<u>(4,313,529.69)</u>
Total Accumulated Depreciation				
Governmental Activities Capital Assets, Net	<u>\$ 13,924,694.88</u>	<u>\$ (274,601.02)</u>	<u>\$ -</u>	<u>\$ 13,650,093.86</u>
Business-Type Activities:				
Capital Assets, being Depreciated:				
Equipment	\$ 178,961.00	\$ -	\$ -	\$ 178,961.00
Less Accumulated Depreciation for:				
Equipment	(107,187.21)	(10,253.40)		(117,440.61)
Business-Type Activities Capital Assets, Net	<u>\$ 71,773.79</u>	<u>\$ (10,253.40)</u>	<u>\$ -</u>	<u>\$ 61,520.39</u>

Depreciation expense was charged to functions / programs of the School District as follows:

Governmental Activities:	
Regular Instruction	\$ 295,410.19
Plant Operations and Maintenance	13,167.52
Transportation	8,722.31
	<u>317,300.02</u>
Total Depreciation Expense - Governmental Activities	<u>\$ 317,300.02</u>
Business-Type Activities:	
Food Service	<u>\$ 10,253.40</u>

Note 7: LONG-TERM LIABILITIES

During the fiscal year ended June 30, 2016, the following changes occurred in long-term obligations for governmental activities:

	<u>Balance</u> <u>July 1, 2015</u>	<u>Additions</u>	<u>Deductions</u>	<u>Balance</u> <u>June 30, 2016</u>	<u>Due within</u> <u>One Year</u>
Governmental Activities:					
Bonds Payable:					
General Obligation Bonds	\$ 5,710,000.00	\$ -	\$ (255,000.00)	\$ 5,455,000.00	\$ 275,000.00
Plus Amounts:					
Issuance Premiums	273,498.89		(21,038.38)	252,460.51	
Total Bonds Payable	<u>5,983,498.89</u>	<u>-</u>	<u>(276,038.38)</u>	<u>5,707,460.51</u>	<u>275,000.00</u>
Other Liabilities:					
Compensated Absences (Note 15)	247,021.27	10,236.24	(534.05)	256,723.46	
Net Pension Liability (Note 9)	1,269,984.00	561,738.00	(174,465.00)	1,657,257.00	
Postemployment Benefits (Note 11)	25,824.87		(3,942.29)	21,882.58	
Total Other Liabilities	<u>1,542,830.14</u>	<u>571,974.24</u>	<u>(178,941.34)</u>	<u>1,935,863.04</u>	<u>-</u>
Governmental Activity Long-Term Liabilities	<u>\$ 7,526,329.03</u>	<u>\$ 571,974.24</u>	<u>\$ (454,979.72)</u>	<u>\$ 7,643,323.55</u>	<u>\$ 275,000.00</u>

The bonds payable are generally liquidated by the debt service fund, while the compensated absences, net pension liability, and postemployment benefits are liquidated by the general fund.

Bonds Payable - Bonds and loans are authorized in accordance with State law by the voters of the municipality through referendums. All bonds are retired in serial installments within the statutory period of usefulness. Bonds issued by the School District are general obligation bonds.

On May 1, 2005, the School District issued \$6,761,000.00 general obligation bonds at interest rates varying from 4.00% to 4.40% for various construction and renovation projects. The final maturity of these bonds was originally August 1, 2027, however, the School District issued refunding bonds on April 24, 2013 to advance refund the bonds maturing on August 1, 2016 through August 1, 2027. The final payment was paid on August 1, 2015.

On April 24, 2013, the School District issued \$5,600,000.00 of refunding bonds at interest rates varying from 2.00% to 5.00% to advance refund the callable bonds of the 2005 issue. The final maturity of these is August 1, 2027. The bonds will be paid from property taxes.

Principal and interest due on bonds outstanding is as follows:

<u>Fiscal Year</u> <u>Ending June 30,</u>	<u>Principal</u>	<u>Interest</u>	<u>Total</u>
2017	\$ 275,000.00	\$ 155,788.00	\$ 430,788.00
2018	375,000.00	146,038.00	521,038.00
2019	390,000.00	134,563.00	524,563.00
2020	410,000.00	122,563.00	532,563.00
2021	435,000.00	109,888.00	544,888.00
2022-2026	2,445,000.00	330,132.00	2,775,132.00
2027-2028	<u>1,125,000.00</u>	<u>33,975.00</u>	<u>1,158,975.00</u>
Total	<u>\$ 5,455,000.00</u>	<u>\$ 1,032,947.00</u>	<u>\$ 6,487,947.00</u>

Bonds Authorized but not Issued - As of June 30, 2016, the School District had no authorizations to issue additional bonded debt.

Note 7: LONG-TERM LIABILITIES (CONT'D)

Compensated Absences - As previously stated, compensated absences will be paid from the fund from which the employees' salaries are paid. Refer to note 15 for a description of the School District's policy. The District does not anticipate any retirements during the fiscal year 2017, therefore, no portion is estimated to be due within one year.

Net Pension Liability - For details on the net pension liability, refer to note 9. The School District's annual required contribution to the Public Employees' Retirement System is budgeted and paid from the general fund on an annual basis.

Note 8: OPERATING LEASES

At June 30, 2016, the School District had operating lease agreements in effect for five copy machines. The present value of the future minimum rental payments under the operating lease agreements are as follows:

<u>Fiscal Year</u> <u>Ending June 30,</u>	<u>Amount</u>
2017	\$ 11,004.84
2018	7,098.04
2019	<u>4,509.76</u>
	<u>\$ 22,612.64</u>

Rental payments under operating leases for the fiscal year ended June 30, 2016 were \$13,514.04.

Note 9: PENSION PLANS

A substantial number of the School District's employees participate in one of the following defined benefit pension plans: the Teachers' Pension and Annuity Fund ("TPAF") and the Public Employees' Retirement System ("PERS"), which are administered by the New Jersey Division of Pensions and Benefits (the "Division"). In addition, several School District employees participate in the Defined Contribution Retirement Program, which is a defined contribution pension plan. This plan is administered by Prudential Financial for the Division. Each plan has a Board of Trustees that is primarily responsible for its administration. The Division issues a publicly available financial report that includes financial statements and required supplementary information. That report may be obtained by writing to:

State of New Jersey
Division of Pensions and Benefits
P.O. Box 295
Trenton, New Jersey 08625-0295
<http://www.nj.gov/treasury/pensions>

Note 9: PENSION PLANS (CONT'D)**General Information about the Pension Plans****Plan Descriptions**

Teachers' Pension and Annuity Fund - The Teachers' Pension and Annuity Fund is a cost-sharing multiple-employer defined benefit pension plan, with a special funding situation, which was established as of January 1, 1955, under the provisions of N.J.S.A. 18A:66. The State of New Jersey (the "State") is responsible to fund 100% of the employer contributions, excluding any local employer early retirement incentive (ERI) contributions. The TPAF's designated purpose is to provide retirement benefits, death, disability and medical benefits to certain qualified members. Membership in the TPAF is mandatory for substantially all teachers or members of the professional staff certified by the State Board of Examiners, who have titles that are unclassified, professional and certified. The TPAF's Board of Trustees is primarily responsible for the administration of the TPAF.

Public Employees' Retirement System - The Public Employees' Retirement System is a cost-sharing multiple-employer defined benefit pension plan which was established as of January 1, 1955, under the provisions of N.J.S.A. 43:15A. The PERS's designated purpose is to provide retirement, death, disability and medical benefits to certain qualified members. Membership in the PERS is mandatory for substantially all full-time employees of the School District, provided the employee is not required to be a member of another state-administered retirement system or other state pensions fund or local jurisdiction's pension fund. The PERS's Board of Trustees is primarily responsible for the administration of the PERS.

Defined Contribution Retirement Program - The Defined Contribution Retirement Program is a multiple-employer defined contribution pension fund established on July 1, 2007 under the provisions of Chapter 92, P.L. 2007, and Chapter 103, P.L. 2007 (N.J.S.A. 43:15C-1 et. seq.). The DCRP is a tax-qualified defined contribution money purchase pension plan under Internal Revenue Code (IRC) § 401(a) et seq., and is a "governmental plan" within the meaning of IRC § 414(d). The DCRP provides retirement benefits for eligible employees and their beneficiaries. Individuals covered under DCRP are employees enrolled in TPAF or PERS on or after July 1, 2007, who earn salary in excess of established "maximum compensation" limits; employees enrolled in SPRS or PFRS after May 21, 2010, who earn salary in excess of established "maximum compensation" limits; employees otherwise eligible to enroll in TPAF or PERS on or after November 2, 2008, who do not earn the minimum annual salary for tier 3 enrollment but who earn salary of at least \$5,000.00 annually; and employees otherwise eligible to enroll in TPAF or PERS after May 21, 2010 who do not work the minimum number of hours per week required for tiers 4 or 5 enrollment, but who earn salary of at least \$5,000.00 annually.

Vesting and Benefit Provisions

Teachers' Pension and Annuity Fund - The vesting and benefit provisions are set by N.J.S.A. 18A:66. TPAF provides retirement, death and disability benefits. All benefits vest after ten years of service, except for medical benefits, which vest after 25 years of service or under the disability provisions of TPAF. Members are always fully vested for their own contributions and, after three years of service credit, become vested for 2% of related interest earned on the contributions. In the case of death before retirement, members' beneficiaries are entitled to full interest credited to the members' accounts.

Note 9: PENSION PLANS (CONT'D)**General Information about the Pension Plans (Cont'd)****Vesting and Benefit Provisions (Cont'd)**

Teachers' Pension and Annuity Fund (Cont'd) - The following represents the membership tiers for TPAF:

Tier Definition

- 1 Members who were enrolled prior to July 1, 2007
- 2 Members who were eligible to enroll on or after July 1, 2007 and prior to November 2, 2008
- 3 Members who were eligible to enroll on or after November 2, 2008 and prior to May 21, 2010
- 4 Members who were eligible to enroll after May 21, 2010 and prior to June 28, 2011
- 5 Members who were eligible to enroll on or after June 28, 2011

Service retirement benefits of 1/55th of final average salary for each year of service credit is available to tiers 1 and 2 members upon reaching age 60 and to tier 3 members upon reaching age 62. Service retirement benefits of 1/60th of final average salary for each year of service credit is available to tier 4 members upon reaching age 62 and tier 5 members upon reaching age 65. Early retirement benefits are available to tiers 1 and 2 members before reaching age 60, tiers 3 and 4 before age 62 with 25 or more years of service credit, and tier 5 before age 65 with 30 or more years of service credit. Benefits are reduced by a fraction of a percent for each month that a member retires prior to the retirement age for his/her respective tier.

Deferred retirement is available to members who have at least 10 years of service credit and have not reached the service retirement age for the respective tier.

Public Employees' Retirement System - The vesting and benefit provisions are set by N.J.S.A. 43:15A and 43:3B. The PERS provides retirement, death and disability benefits. All benefits vest after 10 years of service, except for medical benefits, which vest after 25 years of service or under the disability provisions of the PERS.

The membership tiers for PERS are the same as previously noted for TPAF.

Service retirement benefits of 1/55th of final average salary for each year of service credit is available to tiers 1 and 2 members upon reaching age 60 and to tier 3 members upon reaching age 62. Service retirement benefits of 1/60th of final average salary for each year of service credit is available to tier 4 members upon reaching age 62 and tier 5 members upon reaching age 65. Early retirement benefits are available to tiers 1 and 2 members before reaching age 60, tiers 3 and 4 before age 62 with 25 or more years of service credit and tier 5 with 30 or more years of service credit before age 65. Benefits are reduced by a fraction of a percent for each month that a member retires prior to the age at which a member can receive full early retirement benefits in accordance with their respective tier. Tier 1 members can receive an unreduced benefit from age 55 to age 60 if they have at least 25 years of service. Deferred retirement is available to members who have at least 10 years of service credit and have not reached the service retirement age for the respective tier.

Defined Contribution Retirement Program - Eligible members are provided with a defined contribution retirement plan intended to qualify for favorable Federal income tax treatment under IRC Section 401(a), a noncontributory group life insurance plan and a noncontributory group disability benefit plan. A participant's interest in that portion of his or her defined contribution retirement plan account attributable to employee contributions shall immediately become and shall at all times remain fully vested and non-forfeitable. A participant's interest in that portion of his or her defined contribution retirement plan account attributable to employer contributions shall be vested and nonforfeitable on the date the participant commences the second year of employment or upon his or her attainment of age 65, while employed by an employer, whichever occurs first.

Note 9: PENSION PLANS (CONT'D)**General Information about the Pension Plans (Cont'd)****Contributions**

Teachers' Pension and Annuity Fund - The contribution policy is set by N.J.S.A. 18A:66 and requires contributions by active members and contributing employers. Pursuant to the provisions of Chapter 78, P.L. 2011, the active member contribution rate increased from 5.5% of annual compensation to 6.5% plus an additional 1% phased-in over 7 years beginning in July 2012. The member contribution rate was 7.06% in State fiscal year 2016. The phase-in of the additional incremental member contribution rate takes place in July of each subsequent State fiscal year. The State's pension contribution is based on an actuarially determined amount which includes the employer portion of the normal cost and an amortization of the unfunded accrued liability. Funding for noncontributory group insurance benefits is based on actual claims paid. For fiscal year 2015, the State's pension contribution was less than the actuarial determined amount.

Under current statute, all employer contributions are made by the State of New Jersey on-behalf of the School District and all other related non-contributing employers. No normal or accrued liability contribution by the School District has been required over several preceding fiscal years. These on-behalf contributions by the State of New Jersey are considered a special funding situation, under the definition of GASB 68, *Accounting and Financial Reporting for Pensions*.

The School District's contractually required contribution rate for the fiscal year ended June 30, 2016 was 5.25% of the School District's covered payroll, of which 0.00% of payroll was required from the School District and 100.00% of payroll was required from the State of New Jersey. The School District was not required to make any contributions to the pension plan during the fiscal year ended June 30, 2016 because of the 100.00% special funding situation with the State of New Jersey.

Based on the most recent TPAF measurement date of June 30, 2015, the State's contractually required contribution, on-behalf of the School District, to the pension plan for the fiscal year ended June 30, 2016 was \$133,409.00, and was paid by April 1, 2016. School District employee contributions to the pension plan during the fiscal year ended June 30, 2016 were \$182,128.41.

Public Employees' Retirement System - The contribution policy is set by N.J.S.A. 43:15A and requires contributions by active members and contributing employers. Members contribute at a uniform rate. Pursuant to the provisions of Chapter 78, P.L. 2011, the active member contribution rate increased from 5.5% of annual compensation to 6.5% plus an additional 1% phased-in over 7 years beginning in July 2012. The member contribution rate was 7.06% in State fiscal year 2016. The phase-in of the additional incremental member contribution rate takes place in July of each subsequent State fiscal year. The rate for members who are eligible for the Prosecutors Part of PERS (Chapter 366, P.L. 2001) increased from 8.5% of base salary to 10%. Employers' contribution amounts are based on an actuarially determined rate. The School District's contribution amounts are based on an actuarially determined rate which included the normal cost and unfunded accrued liability.

The School District's contractually required contribution rate for the fiscal year ended June 30, 2016 was 12.92% of the School District's covered payroll. This amount was actuarially determined as the amount that, when combined with employee contributions, is expected to finance the costs of benefits earned by employees during the year, including an additional amount to finance any unfunded accrued liability.

Based on the most recent PERS measurement date of June 30, 2015, the School District's contractually required contribution to the pension plan for the fiscal year ended June 30, 2016 was \$63,471.00, and was paid by April 1, 2016. School District employee contributions to the pension plan during the fiscal year ended June 30, 2016 were \$37,243.94

Note 9: PENSION PLANS (CONT'D)**General Information about the Pension Plans (Cont'd)****Contributions (Cont'd)**

Defined Contribution Retirement Program - The contribution policy is set by N.J.S.A. 43:15C-3 and requires contributions by active members and contributing employers. In accordance with Chapter 92, P.L. 2007 and Chapter 103, P.L. 2007, plan members are required to contribute 5.5% of their annual covered salary. In addition to the employee contributions, the School District contributes 3% of the employees' base salary, for each pay period, to Prudential Financial not later than the fifth business day after the date on which the employee is paid for that pay period.

For the fiscal year ended June 30, 2016, employee contributions totaled \$7,799.97, and the School District recognized pension expense of \$5,435.83. There were no forfeitures during the fiscal year.

Pension Liabilities, Pension Expense, and Deferred Outflows of Resources and Deferred Inflows of Resources Related to Pensions

Teachers' Pension and Annuity Fund - At June 30, 2016, the School District was not required to report a liability for its proportionate share of the net pension liability because of a 100% special funding situation by the State of New Jersey.

The State's proportionate share of net pension liability, attributable to the School District is as follows:

School District's Proportionate Share of Net Pension Liability	\$ -
State of New Jersey's Proportionate Share of Net Pension Liability Associated with the School District	15,689,637.00
	<u>\$ 15,689,637.00</u>

The net pension liability was measured as of June 30, 2015, and the total pension liability used to calculate the net pension liability was determined by an actuarial valuation as of July 1, 2014. The total pension liability was calculated through the use of updated procedures to roll forward from the actuarial valuation date to the measurement date of June 30, 2015. For the June 30, 2015 measurement date, the School District's proportion of the net pension liability was based on a projection of the School District's long-term share of contributions to the pension plan relative to the projected contributions of all participating employers and the State of New Jersey, actuarially determined. At June 30, 2015, the School District proportion was 0.00% due to the 100% special funding situation with the State of New Jersey. For the June 30, 2015 measurement date, the State's proportionate share of the TPAF net pension liability associated with the School District was 0.0248236985%, which was a decrease of 0.0007141773% from its proportion measured as of June 30, 2014.

For the fiscal year ended June 30, 2016, the School District recognized \$957,994.00 in pension expense and revenue, in the government-wide financial statements, for the State of New Jersey on-behalf TPAF pension contributions. This pension expense and revenue was based on the pension plans June 30, 2015 measurement date.

Note 9: PENSION PLANS (CONT'D)**Pension Liabilities, Pension Expense, and Deferred Outflows of Resources and Deferred Inflows of Resources Related to Pensions (Cont'd)**

Public Employees' Retirement System - At June 30, 2016, the School District reported a liability of \$1,657,257.00 for its proportionate share of the net pension liability. The net pension liability was measured as of June 30, 2015, and the total pension liability used to calculate the net pension liability was determined by an actuarial valuation as of July 1, 2014. The total pension liability was calculated through the use of updated procedures to roll forward from the actuarial valuation date to the measurement date of June 30, 2015. The School District's proportion of the net pension liability was based on a projection of the School District's long-term share of contributions to the pension plan relative to the projected contributions of all participating employers, actuarially determined. For the June 30, 2015 measurement date, the School District's proportion was 0.0073826512%, which was an increase of 0.0005995388% from its proportion measured as of June 30, 2014.

For the fiscal year ended June 30, 2016, the School District recognized pension expense of \$118,890.00, in the government-wide financial statements. This pension expense was based on the pension plans June 30, 2015 measurement date.

At June 30, 2016, the School District reported deferred outflows of resources and deferred inflows of resources related to PERS from the following sources:

	<u>Deferred Outflows of Resources</u>	<u>Deferred Inflows of Resources</u>
Differences between Expected and Actual Experience	\$ 39,536.00	\$ -
Changes of Assumptions	177,976.00	-
Net Difference between Projected and Actual Earnings on Pension Plan Investments	-	26,646.00
Changes in Proportion and Differences between School District Contributions and Proportionate Share of Contributions	95,233.00	44,413.00
School District Contributions Subsequent to the Measurement Date	68,167.00	-
	<u>\$ 380,912.00</u>	<u>\$ 71,059.00</u>

Note 9: PENSION PLANS (CONT'D)**Pension Liabilities, Pension Expense, and Deferred Outflows of Resources and Deferred Inflows of Resources Related to Pensions (Cont'd)**

Public Employees' Retirement System (Cont'd) - \$68,167.00 included in deferred outflows of resources, will be included as a reduction of the net pension liability in the fiscal year ending June 30, 2017. Other amounts reported as deferred outflows of resources and deferred inflows of resources related to pensions will be recognized in pension expense as follows:

Year Ending June 30,			
2017	\$	44,690.00	
2018		44,690.00	
2019		44,690.00	
2020		63,608.00	
2021		44,008.00	
		<u>44,008.00</u>	
	\$	<u>241,686.00</u>	

The amortization of the above other deferred outflows of resources and deferred inflows of resources related to pensions will be over the following number of years:

	<u>Deferred Outflows of Resources</u>	<u>Deferred Inflows of Resources</u>
Differences between Expected and Actual Experience		
Year of Pension Plan Deferral:		
June 30, 2014	-	-
June 30, 2015	5.72	-
Changes of Assumptions		
Year of Pension Plan Deferral:		
June 30, 2014	6.44	-
June 30, 2015	5.72	-
Net Difference between Projected and Actual Earnings on Pension Plan Investments		
Year of Pension Plan Deferral:		
June 30, 2014	-	5.00
June 30, 2015	-	5.00
Changes in Proportion and Differences between School District Contributions and Proportionate Share of Contributions		
Year of Pension Plan Deferral:		
June 30, 2014	6.44	6.44
June 30, 2015	5.72	5.72

Note 9: PENSION PLANS (CONT'D)**Actuarial Assumptions**

The net pension liability was measured as of June 30, 2015, and the total pension liability used to calculate the net pension liability was determined by an actuarial valuation as of July 1, 2014. The total pension liability was calculated through the use of updated procedures to roll forward from the actuarial valuation date to the measurement date of June 30, 2015. This actuarial valuation used the following actuarial assumptions, applied to all periods included in the measurement:

	<u>TPAF</u>	<u>PERS</u>
Inflation	2.50%	3.04%
Salary Increases:		
2012-2021	Varies Based on Experience	2.15% - 4.40% Based on Age
Thereafter	Varies Based on Experience	3.15% - 5.40% Based on Age
Investment Rate of Return	7.90%	7.90%
Mortality Rate Table	RP-2000	RP-2000
Period of Actuarial Experience		
Study upon which Actuarial		
Assumptions were Based	July 1, 2009 - June 30, 2012	July 1, 2008 - June 30, 2011

For TPAF, mortality rates were based on the RP-2000 Health Annuitant Mortality Table for Males or Females, as appropriate, with adjustments for mortality improvements were based on Scale AA. Pre-retirement mortality improvements for active members are projected using Scale AA from the base year of 2000 until the valuation date plus 15 years to account for future mortality improvement. Post-retirement mortality improvements for non-disabled annuitants are projected using Scale AA from the base year of 2000 for males and 2003 for females until the valuation date plus 7 years to account for future mortality improvement.

For PERS, mortality rates were based on the RP-2000 Combined Healthy Male and Female Mortality Tables (setback 1 year for males and females) for service retirement and beneficiaries of former members with adjustments for mortality improvements from the base year of 2012 based on Projection Scale AA. The RP-2000 Disabled Mortality Tables (setback 3 years for males and setback 1 year for females) are used to value disabled retirees.

For TPAF and PERS, in accordance with State statute, the long-term expected rate of return on plan investments (7.90% at June 30, 2015) is determined by the State Treasurer, after consultation with the Directors of the Division of Investments and Division of Pensions and Benefits, the board of trustees and the actuaries. The long-term expected rate of return was determined using a building block method in which best-estimate ranges of expected future real rates of return (expected returns, net of pension plan investment expense and inflation) are developed for each major asset class. These ranges are combined to produce the long-term expected rate of return by weighting the expected future real rates of return by the target asset allocation percentage and by adding expected inflation. Best estimates of arithmetic rates of return for each major asset class included in TPAF's and PERS's target asset allocation as of June 30, 2015 are summarized in the following tables:

Note 9: PENSION PLANS (CONT'D)**Actuarial Assumptions (Cont'd)**

<u>Asset Class</u>	<u>TPAF</u>		<u>Asset Class</u>	<u>PERS</u>	
	<u>Target Allocation</u>	<u>Long-Term Expected Real Rate of Return</u>		<u>Target Allocation</u>	<u>Long-Term Expected Real Rate of Return</u>
US Cash	5.00%	0.53%	Cash	5.00%	1.04%
US Government Bonds	1.75%	1.39%	U.S. Treasuries	1.75%	1.64%
US Credit Bonds	13.50%	2.72%	Investment Grade Credit	10.00%	1.79%
US Mortgages	2.10%	2.54%	Mortgages	2.10%	1.62%
US Inflation-Indexed Bonds	1.50%	1.47%	High Yield Bonds	2.00%	4.03%
US High Yield Bonds	2.00%	4.57%	Inflation-Indexed Bonds	1.50%	3.25%
US Equity Market	27.25%	5.63%	Broad U.S. Equities	27.25%	8.52%
Foreign-Developed Equity	12.00%	6.22%	Developed Foreign Equities	12.00%	6.88%
Emerging Markets Equity	6.40%	8.46%	Emerging Market Equities	6.40%	10.00%
Private Real Estate Property	4.25%	3.97%	Private Equity	9.25%	12.41%
Timber	1.00%	4.09%	Hedge Funds/Absolute Return	12.00%	4.72%
Farmland	1.00%	4.61%	Real Estate (Property)	2.00%	6.83%
Private Equity	9.25%	9.15%	Commodities	1.00%	5.32%
Commodities	1.00%	3.58%	Global Debt ex U.S.	3.50%	-0.40%
Hedge Funds - MultiStrategy	4.00%	4.59%	REIT	4.25%	5.12%
Hedge Funds - Equity Hedge	4.00%	5.68%			
Hedge Funds - Distressed	4.00%	4.30%			
				<u>100.00%</u>	
	<u>100.00%</u>				

Discount Rate - The discount rates used to measure the total pension liability were 4.13% and 4.68% for TPAF as of June 30, 2015 and 2014, respectively, and 4.90% and 5.39% for PERS as of June 30, 2015 and 2014, respectively. For TPAF and PERS, the respective single blended discount rates were based on the long-term expected rate of return on pension plan investments of 7.90%, and a municipal bond rate of 3.80% as of June 30, 2015, based on the Bond Buyer Go 20-Bond Municipal Bond Index which includes tax-exempt general obligation municipal bonds with an average rating of AA/Aa or higher. The projection of cash flows used to determine the discount rates for TPAF and PERS assumed that contributions from plan members will be made at the current member contribution rates and that contributions from employers will be made based on the average of the last five years actuarially determined contributions. Based on those assumptions, the plan's fiduciary net position was projected to be available to make projected future benefit payments of current plan members through 2027 for TPAF and 2033 for PERS. Therefore, the long-term expected rate of return on plan investments was applied to projected benefit payments through 2027 for TPAF and 2033 for PERS, and the municipal bond rate was applied to projected benefit payments after that date in determining the total pension liability.

Note 9: PENSION PLANS (CONT'D)**Sensitivity of School District's Proportionate Share of Net Pension Liability to Changes in the Discount Rate**

Teachers' Pension and Annuity Fund (TPAF) - As previously mentioned, TPAF, has a special funding situation where the State pays 100% of the School District's annual required contribution. As such, the proportionate share of the net pension liability as of June 30, 2015, the pension plans measurement date, attributable to the School District is \$0, and the State of New Jersey's proportionate share of the net pension liability, attributable to the School District, using a discount rate of 4.13%, as well as using a discount rate that is 1% lower or 1% higher than the current rates used is as follows:

	TPAF		
	1% Decrease (3.13%)	Current Discount Rate (4.13%)	1% Increase (5.13%)
School District's Proportionate Share of the Net Pension Liability	\$ -	\$ -	\$ -
State of New Jersey's Proportionate Share of Net Pension Liability associated with the School District	18,646,547.00	15,689,637.00	13,142,082.00
	<u>\$ 18,646,547.00</u>	<u>\$ 15,689,637.00</u>	<u>\$ 13,142,082.00</u>

Public Employees' Retirement System (PERS) - The following presents the School District's proportionate share of the net pension liability at June 30, 2015, the plans measurement date, calculated using a discount rate of 4.90%, as well as what the School District's proportionate share of the net pension liability would be if it were calculated using a discount rate that is 1% lower or 1% higher than the current rates used:

	PERS		
	1% Decrease (3.90%)	Current Discount Rate (4.90%)	1% Increase (5.90%)
School District's Proportionate Share of the Net Pension Liability	\$ 2,059,768.00	\$ 1,657,257.00	\$ 1,319,795.00

Pension Plan Fiduciary Net Position

For purposes of measuring the net pension liability, deferred outflows of resources and deferred inflows of resources related to pensions, and pension expense, information about the respective fiduciary net position of the TPAF and PERS and additions to/deductions from TPAF and PERS' respective fiduciary net position have been determined on the same basis as they are reported by TPAF and PERS. Accordingly, benefit payments (including refunds of employee contributions) are recognized when due and payable in accordance with the benefit terms. Investments are reported at fair value. For additional information about TPAF and PERS, please refer to the plan's Comprehensive Annual Financial Report (CAFR) which can be found at www.nj.gov/treasury/pensions/annrpts.shtml.

Note 10: STATE POST-RETIREMENT MEDICAL BENEFITS

P.L. 1987, c.384 of P.L. 1990, c.6 required Teachers' Pensions and Annuity Fund ("TPAF") and the Public Employees' Retirement System ("PERS"), respectively, to fund post-retirement medical benefits for those State employees who retire after accumulating 25 years of credited service or on a disability retirement. P.L. 2007, c.103 amended the law to eliminate the funding of postemployment medical benefits through the TPAF and PERS. It created separate funds outside of the pension plans for the funding and payment of postemployment medical benefits for retired State employees and retired educational employees. As of June 30, 2015, there were 107,314 retirees receiving postemployment medical benefits, and the State contributed \$1.25 billion on their behalf. The cost of these benefits is funded through contributions by the State in accordance with P.L. 1994, c.62. Funding of post-retirement medical premiums changed from a pre-funding basis to a pay-as-you-go basis beginning in fiscal year 1994.

The State is also responsible for the cost attributable to P.L. 1992 c.126, which provides free health benefits to members of PERS and the Alternate Benefit Program who retire from a board of education or county college with 25 years of service. The State paid \$214.1 million toward Chapter 126 benefits for 19,056 eligible retired members in fiscal year 2015.

Note 11: POSTEMPLOYMENT BENEFITS OTHER THAN PENSION BENEFITS

Plan Description - The School District provides postretirement health care benefits through a health plan for retirees, which includes medical and dental. The School District's plan covers on retired employee and one retired employee's spouse. The plan is administered by the School District; therefore, premium payments are made directly to the insurance carriers.

Funding Policy - Only these two retirees, who were previous superintendents, were eligible for retirement benefits. The contribution requirements of plan members and the School District are established and may be amended by the School District's Board of Education.

Retirees - The School District presently funds its current retiree postretirement benefit costs on a "pay-as-you-go" basis. The School District's contributions to the plan for the fiscal years ended June 30, 2016, 2015, and 2014 were \$7,019.88, \$6,523.56, and \$6,276.26 respectively.

Annual OPEB Cost - For the fiscal year 2016, the School District's annual OPEB cost (expense) of \$3,077.59 for the plan was equal to the ARC plus certain adjustments because the School District's actual contributions in prior years differed from the ARC.

The School District's annual required contribution (ARC), the interest on the net OPEB obligation, the adjustment to the ARC, the increase or decrease in the net OPEB obligation, the net OPEB obligation and the percentage of annual OPEB cost contributed to the plan for fiscal years 2016, 2015 and 2014 are as follows:

	<u>2016</u>	<u>2015</u>	<u>2014</u>
Annual Required Contribution (ARC)	\$ 1,287.21	\$ 1,434.72	\$ 1,106.49
Interest on the Net OPEB Obligation	-	-	-
Adjustment to the ARC	1,790.38	10,996.82	(21,911.39)
Annual OPEB Cost	3,077.59	12,431.54	(20,804.90)
Pay-as-You Go Cost (Existing Retirees)	(7,019.88)	(6,523.56)	(6,276.26)
Increase (Decrease) in the Net OPEB Obligation	(3,942.29)	5,907.98	(27,081.16)
Net OPEB Obligation, July 1	25,824.87	19,916.89	46,998.05
Net OPEB Obligation, June 30	<u>\$ 21,882.58</u>	<u>\$ 25,824.87</u>	<u>\$ 19,916.89</u>
Percentage of Annual OPEB Cost Contributed	228.1%	52.5%	-30.2%

Note 11: POSTEMPLOYMENT BENEFITS OTHER THAN PENSION BENEFITS (CONT'D)

Funded Status and Funding Progress - The funded status of the plan as of June 30, 2016, was as follows:

Actuarial Accrued Liability (AAL)	\$ 21,882.58
Actuarial Value of Plan Assets	<u>-</u>
Unfunded Actuarial Accrued Liability (UAAL)	<u>\$ 21,882.58</u>
Funded Ratio (Actuarial Value of Plan Assets / AAL)	0.0%
Covered Payroll (Active Plan Members)	N/A
UAAL as a Percentage of Covered Payroll	N/A

Actuarial valuations of an ongoing plan involve estimates of the value of reported amounts and assumptions about the probability of occurrence of events far into the future. Examples include assumptions about future employment, mortality, and the healthcare cost trend. Amounts determined regarding the funded status of the plan and the annual required contributions of the employer are subject to continual revision as actual results are compared with past expectations and new estimates are made about the future. The schedule of funding progress, presented as required supplementary information following the notes to the financial statements, presents multiyear trend information that shows whether the actuarial value of the plan assets is increasing or decreasing over time relative to the actuarial accrued liabilities for benefits.

Actuarial Methods and Assumptions - The projections of benefits for financial reporting purposes are based on the substantive plan (the plan as understood by the employer and plan members) and include the types of benefits provided at the time of each valuation and the historical pattern of sharing benefit costs between the employer and plan members to that point. The actuarial methods and assumptions used include techniques that are designed to reduce short-term volatility in actuarial accrued liabilities and the actuarial value of assets, consistent with the long-term perspective of the calculations.

In the June 30, 2016 actuarial valuation, the projected unit credit actuarial cost method was used. Under this method, an actuarial accrued liability is determined as the actuarial present value of the portion of projected benefits which is allocated to service before the current plan year. In addition, a normal cost is determined as the actuarial present value of the portion of projected benefits which is allocated to service in the current plan year for each active participant under the assumed retirement age. The UAAL is being amortized (straight-line) for thirty (30) years on an open basis. The actuarial assumptions included the following:

- *Mortality.* RP 2000 Combined Healthy Male Mortality Rates set forward three years.
- *Turnover.* Zero.
- *Annual Discount Rate.* Future costs have been discounted at the rate of 3.0% compounded annually for GASB 45 purposes.
- *Medical Trend.* 3% per annum.

Note 12: ON-BEHALF PAYMENTS

For the fiscal year ended June 30, 2016, the School District has recognized as revenues and expenditures on-behalf payments made by the State for normal costs and post-retirement medical costs related to TPAF, in the fund financial statements. The amounts recognized as revenues and expenditures in the fund financial statements for normal costs, post-retirement medical costs, and non-contributory insurance were \$176,281.00, \$220,359.00 and \$8,781.00, respectively.

Note 13: RISK MANAGEMENT

The School District is exposed to various risks of loss related to torts; theft of, damage to, and destruction of assets; errors and omissions; injuries to employees; and natural disasters.

Property and Liability Insurance - The School District maintains commercial insurance coverage for property, liability, student accident, and surety bonds. A complete schedule of insurance coverage can be found in the statistical section of this Comprehensive Annual Financial Report.

Joint Insurance Pool - The School District is a member of the Burlington County Insurance Pool Joint Insurance Fund. The Fund provides its members with the following coverage:

Property, Inland Marine and Auto Physical Damage
Boiler and Machinery
Comprehensive Crime
General and Automobile Liability
Workers Compensation
Educator's Legal Liability
Pollution Legal Liability
Cyber Liability

Annual contributions to the Fund are determined by the Fund's Board of Trustees. The School District is jointly and personally liable for claims insured by the Fund and its members during the period of its membership, including liability for supplemental assessments, if necessary. The Fund's Board of Trustees may authorize refunds to its members in any fund year for which contributions exceed the amount necessary to fund its obligations for that year.

The Fund publishes its own financial report for the fiscal year ended June 30, 2016, which can be obtained from:

Burlington County Insurance Pool Joint Insurance Fund
P.O. Box 449
Marlton, New Jersey 08053

Note 14: DEFERRED COMPENSATION

The School District offers its employees a deferred compensation plan created in accordance with Internal Revenue Code Sections 403(b) and 457. The plans, which are administered by the entities listed below, permit participants to defer a portion of their salary until future years. Amounts deferred under the plans are not available to employees until termination, retirement, death, or unforeseeable emergency. The plan administrator is as follows:

TSA Consulting Group

Note 15: COMPENSATED ABSENCES

The School District accounts for compensated absences (e.g., unused vacation, sick leave) as directed by Governmental Accounting Standards Board Statement No. 16 (GASB 16), *Accounting for Compensated Absences*. A liability for compensated absences attributable to services already rendered and not contingent on a specific event that is outside the control of the employer and employee is accrued as employees earn the rights to the benefits.

Note 15: COMPENSATED ABSENCES (CONT'D)

School District employees who are employed for ten months are entitled to ten paid sick leave days per fiscal school year. School District employees who are employed for twelve months are entitled to twelve paid sick leave days per fiscal school year. Unused sick leave may be accumulated and carried forward to the subsequent years. School District employees are entitled to two personal days which may be carried forward to subsequent years. Employees who retire from the Delanco School System shall receive twenty percent of their daily pay rate for accumulated sick days up to a maximum of \$13,000.00.

Certain twelve month employees are permitted to carry over a maximum of five unused vacation days from one fiscal year to the subsequent year, however, at no time will available vacation days be allowed to accumulate in excess of 25 days in any one fiscal year. Upon retirement from the district, payment is made for any unused vacation time.

The liability for vested compensated absences is recorded within those funds as the benefits accrue to employees. At June 30, 2016, the liability for compensated absences reported on the government-wide statement of net position was \$256,723.46.

Note 16: INTERFUND RECEIVABLES, PAYABLES, AND TRANSFERS

The composition of interfund balances as of June 30, 2016 is as follows:

<u>Fund</u>	<u>Interfunds Receivable</u>	<u>Interfunds Payable</u>
General	\$ 31,081.13	\$ -
Special Revenue		31,031.76
Fiduciary		49.37
	<u>\$ 31,081.13</u>	<u>\$ 31,081.13</u>

The interfund receivables and payables above predominately resulted from payments made by certain funds on behalf of other funds. During the fiscal year 2017, the School District expects to liquidate such interfunds, depending upon the availability of cash flow.

Note 17: DEFEASED DEBT

In prior years, the School District defeased certain general obligation bonds by placing the proceeds of new bonds in a separate irrevocable trust fund. The investments and fixed interest earnings from the investments are sufficient to fully service the defeased debt until the debt is called or matures. For financial reporting purposes, the debt is considered defeased and therefore removed as a liability from the School District's financial statements. As of June 30, 2016, the total amount of defeased debt outstanding, but removed from the School District's financial statements, is \$5,296,000.00.

Note 18: CONTINGENCIES

Grantor Agencies - Amounts received or receivable from grantor agencies could be subject to audit and adjustment by grantor agencies. Any disallowed claims, including amounts already collected, may constitute a liability of the applicable funds. The amount, if any, of expenditures which may be disallowed by the grantor cannot be determined at this time, although the School District expects such amount, if any, to be immaterial.

Note 18: CONTINGENCIES (CONT'D)

Litigation - The School District is a defendant in several legal proceedings that are in various stages of litigation. It is believed that the outcome, or exposure to the School District, from such litigation is either unknown or potential losses, if any, would not be material to the financial statements.

Note 19: CONCENTRATIONS

The School District depends on financial resources flowing from, or associated with, both the federal government and the State of New Jersey. As a result of this dependency, the School District is subject to changes in specific flows of intergovernmental revenues based on modifications to federal and State laws and federal and State appropriations.

Note 20: FUND BALANCES**RESTRICTED**

As stated in note 1, the restricted fund balance classification includes amounts that are restricted to specific purposes. Such restrictions, or constraints, are placed on the use of resources by either of the following: (1) externally imposed by creditors, grantors, contributors, or laws or regulations of other governments; or (2) imposed by law through constitutional provisions or enabling legislation. Specific restrictions of the School District's fund balance are summarized as follows:

General Fund

For Excess Surplus - In accordance with N.J.S.A. 18A:7F-7, as amended, the designation of restricted fund balance - excess surplus is the result of a required calculation pursuant to the New Jersey Comprehensive Educational Improvement and Financing Act of 1996 (CEIFA). New Jersey school districts are required to restrict general fund balance at the fiscal year end of June 30 if they did not appropriate a required minimum amount as budgeted fund balance in their subsequent years' budget. The excess fund balance at June 30, 2016 is \$1,451,114.36. Additionally, \$1,344,935.78 of excess fund balance generated during 2014-2015 has been restricted and designated for utilization in the 2016-2017 budget.

For Capital Reserve Account - As of June 30, 2016, the balance in the capital reserve account is \$513,175.84. These funds are restricted for future capital outlay expenditures for capital projects in the School District's approved Long Range Facilities Plan (LRFP).

Debt Service Fund - In accordance with N.J.A.C. 6A:23A-8.6, a district board of education shall appropriate annually all debt service fund balances in the budget certified for taxes unless expressly authorized and documented by the voters in a bond referendum. As a result, the School District has appropriated and included as an anticipated revenue for the fiscal year ending June 30, 2017 \$5,554.43 of debt service fund balance at June 30, 2016.

ASSIGNED

As stated in note 1, the assigned fund balance classification includes amounts that are constrained by the School District's *intent* to be used for specific purposes, but are neither restricted nor committed. Specific assignments of the School District's fund balance are summarized as follows:

General Fund

For Subsequent Year's Expenditures - The School District has appropriated and included as an anticipated revenue for the fiscal year ending June 30, 2017 \$37,622.22 of general fund balance at June 30, 2016.

Note 20: FUND BALANCES (CONT'D)**ASSIGNED (CONT'D)****General Fund (Cont'd)**

Other Purposes - As of June 30, 2016, the School District had \$1,385.05 of encumbrances outstanding for purchase orders and contracts signed by the School District, but not completed, as of the close of the fiscal year.

UNASSIGNED

As stated in note 1, the unassigned fund balance classification represents fund balance that has not been restricted, committed, or assigned to specific purposes. The School District's unassigned fund balance is summarized as follows:

General Fund - As of June 30, 2016, \$110,787.00 of general fund balance was unassigned.

REQUIRED SUPPLEMENTARY INFORMATION
PART II

BUDGETARY COMPARISON SCHEDULES

TOWNSHIP OF DELANCO SCHOOL DISTRICT

General Fund
 Required Supplementary Information
 Budgetary Comparison Schedule
 For the Fiscal Year Ended June 30, 2016

	Original Budget	Budget Modifications	Final Budget	Actual	Variance Positive (Negative) Final to Actual
REVENUES:					
Local Sources:					
Local Tax Levy	\$ 5,560,840.00	\$ -	\$ 5,560,840.00	\$ 5,560,840.00	\$ -
Tuition	250.00		250.00	55,264.00	55,264.00
Interest Earned on Capital Reserve Funds	58,301.00		58,301.00	903.61	653.61
Unrestricted Miscellaneous Revenues				76,972.08	18,671.08
Total - Local Sources	5,619,391.00	-	5,619,391.00	5,693,979.69	74,588.69
State Sources:					
Categorical Special Education Aid	313,392.00		313,392.00	313,392.00	
Equalization Aid	2,114,805.00		2,114,805.00	2,114,805.00	
Categorical Security Aid	22,608.00		22,608.00	22,608.00	
Categorical Transportation Aid	24,250.00		24,250.00	24,250.00	
PARCC Readiness Aid	5,300.00		5,300.00	5,300.00	
Per Pupil Growth Aid	5,300.00		5,300.00	5,300.00	
Extraordinary Aid				65,798.00	65,798.00
Non Public Transportation Aid				4,002.00	4,002.00
Reimbursed TPAF Social Security Contributions (non-budgeted)				182,215.44	182,215.44
On-behalf TPAF Pension Contributions - Normal Cost (non-budgeted)				176,281.00	176,281.00
On-behalf TPAF Pension Contributions - Insurance (non-budgeted)				8,781.00	8,781.00
On-behalf TPAF Medical Contributions (non-budgeted)				220,359.00	220,359.00
Total - State Sources	2,485,655.00	-	2,485,655.00	3,143,091.44	657,436.44
Total Revenues	8,105,046.00	-	8,105,046.00	8,837,071.13	732,025.13

TOWNSHIP OF DELANCO SCHOOL DISTRICT

General Fund
 Required Supplementary Information
 Budgetary Comparison Schedule
 For the Fiscal Year Ended June 30, 2016

	Original Budget	Budget Modifications	Final Budget	Actual	Variance Positive (Negative) Final to Actual
EXPENDITURES:					
GENERAL CURRENT EXPENSE:					
Regular Programs - Instruction:					
Salaries of Teachers:					
Preschool/Kindergarten	\$ 177,612.00	\$ 7,235.02	\$ 184,847.02	\$ 184,847.02	\$ -
Grades 1 - 5	972,939.00	(76,186.31)	896,752.69	893,277.46	3,475.23
Grades 6 - 8	570,207.00	28,625.44	598,832.44	598,832.44	
Regular Programs - Home Instruction:					
Home Instruction Salaries	8,000.00	7,010.00	15,010.00	13,210.25	1,799.75
Purchased Professional/Educational Services	2,000.00	(1,600.00)	400.00	400.00	
Purchased Professional/Educational Services	78,633.00	1,034.10	79,667.10	74,467.71	5,199.39
Rentals		8,579.20	8,579.20	6,301.76	2,277.44
Other Purchased Services	53,600.00	(47,400.00)	6,200.00	1,005.00	5,195.00
Travel		2,000.00	2,000.00	14.88	1,985.12
Miscellaneous Purchased Services		30,000.00	30,000.00	12,146.48	17,853.52
General Supplies	185,339.74	(8,162.00)	177,177.74	99,392.93	77,784.81
Textbooks	65,000.00		65,000.00	60,000.00	5,000.00
Other Objects	3,000.00		3,000.00		3,000.00
Total Regular Programs	2,116,330.74	(48,864.55)	2,067,466.19	1,943,895.93	123,570.26
Special Education:					
Learning and/or Language Disabilities:					
Salaries of Teachers	119,686.00	(42,692.46)	76,993.54	69,849.94	7,143.60
Other Salaries for Instruction	25,926.00	(11,848.00)	14,078.00	7,781.57	6,296.43
Purchased Professional Educational Services	1,000.00	(1,000.00)			
General Supplies	1,350.00	(850.91)	499.09	449.52	49.57
Textbooks	750.00		750.00		750.00
Total - Learning and/or Language Disabilities	148,712.00	(56,391.37)	92,320.63	78,081.03	14,239.60
Multiple Disabled:					
Other Salaries for Instruction	64,115.00	5,184.34	69,299.34	69,299.34	
Total - Multiply Disabled	64,115.00	5,184.34	69,299.34	69,299.34	-

(Continued)

TOWNSHIP OF DELANCO SCHOOL DISTRICT

General Fund
 Required Supplementary Information
 Budgetary Comparison Schedule
 For the Fiscal Year Ended June 30, 2016

	Original Budget	Budget Modifications	Final Budget	Actual	Variance Positive (Negative) Final to Actual
EXPENDITURES (CONT'D):					
GENERAL CURRENT EXPENSE (CONT'D):					
Special Education (Cont'd):					
Resource Room/Center:					
Salaries of Teachers	\$ 258,087.00	\$ 43,881.97	\$ 301,968.97	\$ 277,102.28	\$ 24,866.69
Other Salaries for Instruction	85,678.00	(4,843.29)	80,834.71	65,318.90	15,515.81
General Supplies	7,000.00		7,000.00	5,459.77	1,540.23
Textbooks	1,100.00		1,100.00		1,100.00
Total - Resource Room/Center	351,865.00	39,038.68	390,903.68	347,880.95	43,022.73
Special Education - Home Instruction:					
Purchased Professional/Educational Services	2,000.00		2,000.00		2,000.00
Total - Special Education - Home Instruction:	2,000.00	-	2,000.00	-	2,000.00
Total - Special Education	566,692.00	(12,168.35)	554,523.65	495,261.32	59,262.33
Basic Skills/Remedial:					
Salaries of Teachers	60,018.00	300.00	60,318.00	57,318.00	3,000.00
General Supplies	1,000.00		1,000.00	379.64	620.36
Total - Basic Skills/Remedial	61,018.00	300.00	61,318.00	57,697.64	3,620.36
School Sponsored Cocurricular Activities - Instruction:					
Salaries	27,996.00		27,996.00	16,872.00	11,124.00
Supplies and Materials	825.00		825.00		825.00
Other Objects	250.00		250.00		250.00
Total - School Sponsored Cocurricular Activities - Instruction	29,071.00	-	29,071.00	16,872.00	12,199.00
School Sponsored Athletics - Instruction:					
Salaries	15,652.00		15,652.00	11,732.00	3,920.00
Purchased Professional and Technical Services	3,370.00		3,370.00	2,157.00	1,213.00
Supplies and Materials	3,575.00		3,575.00	3,059.02	515.98
Total - School Sponsored Athletics - Instruction	22,597.00	-	22,597.00	16,948.02	5,648.98

TOWNSHIP OF DELANCO SCHOOL DISTRICT

General Fund
 Required Supplementary Information
 Budgetary Comparison Schedule
 For the Fiscal Year Ended June 30, 2016

	Original Budget	Budget Modifications	Final Budget	Actual	Variance Positive (Negative) Final to Actual
EXPENDITURES (CONTD):					
GENERAL CURRENT EXPENSE (CONTD):					
Undistributed Expenditures - Instruction:					
Tuition to Other LEAs within State - Regular	\$ 1,277,662.00	\$ (14,136.00)	\$ 1,263,526.00	\$ 1,042,683.45	\$ 220,842.55
Tuition to Other LEAs within State - Special	351,730.00		351,730.00	267,918.20	83,811.80
Tuition to County Voc School District - Regular	73,232.00	12,736.00	85,968.00	85,967.40	0.60
Tuition to County Voc School District - Special	6,368.00		6,368.00	6,368.00	
Tuition to CSSD and Reg. Day Schools	451,155.00		451,155.00	397,687.00	53,468.00
Tuition to Private School for the Handicapped - State	448,325.00		448,325.00	251,263.22	197,061.78
Tuition to Private School for the Handicapped - Out of State	45,725.00		45,725.00	4,771.62	40,953.38
Tuition - State Facilities	32,306.00		32,306.00	32,306.00	
Total Undistributed Expenditures - Instruction	2,686,503.00	(1,400.00)	2,685,103.00	2,088,964.89	596,138.11
Total - Instruction	5,482,211.74	(62,132.90)	5,420,078.84	4,619,639.80	800,439.04
Undistributed Expenditures: Attendance and Social Work:					
Salaries	13,908.00		13,908.00	13,471.44	436.56
Total Attendance and Social Work	13,908.00	-	13,908.00	13,471.44	436.56
Health Services:					
Salaries	176,922.00	600.00	177,522.00	151,491.92	26,030.08
Other Purchased Professional and Technical Services	3,280.00	(2,123.40)	1,156.60	916.50	240.10
Other Purchased Services	1,000.00		1,000.00	339.00	661.00
Supplies and Materials	5,200.00		5,200.00	2,432.36	2,767.64
Other Objects	400.00		400.00	400.00	
Total Health Services	186,802.00	(1,523.40)	185,278.60	155,179.78	30,098.82
Other Support Services-Students-Related Services:					
Salaries	86,086.00		86,086.00	86,086.00	
Purchased Professional-Educational Services	53,600.00	(1,113.80)	52,486.20	25,222.96	27,263.24
Supplies and Materials	1,000.00	(72.00)	928.00	927.65	0.35
Total - Other Support Services-Students-Related Services	140,686.00	(1,185.80)	139,500.20	112,236.61	27,263.59

TOWNSHIP OF DELANCO SCHOOL DISTRICT

General Fund
 Required Supplementary Information
 Budgetary Comparison Schedule
 For the Fiscal Year Ended June 30, 2016

	Original Budget	Budget Modifications	Final Budget	Actual	Variance Positive (Negative) Final to Actual
EXPENDITURES (CONT'D):					
GENERAL CURRENT EXPENSE (CONT'D):					
Undistributed Expenditures (Cont'd):					
Other Support Services - Extra Services:					
Salaries	\$ -	\$ 25,926.00	\$ 25,926.00	\$ 25,926.00	\$ -
Supplies and Materials		72.00	72.00	72.00	
Total - Other Support Services - Students - Extra Services	-	25,998.00	25,998.00	25,998.00	-
Other Support Services - Students - Regular:					
Salaries	50,675.00	37,409.30	88,084.30	88,025.05	59.25
Other Purchased Professional and Technical Services	300.00	(185.50)	114.50	580.60	114.50
Travel	750.00		750.00	169.40	169.40
Supplies and Materials	1,250.00	(291.50)	958.50	804.65	153.85
Total Other Support Services - Students - Regular	52,975.00	36,932.30	89,907.30	89,410.30	497.00
Other Support Services - Students - Special Services:					
Purchased Professional-Educational Services	6,700.00	(3,470.50)	3,229.50	1,522.45	1,707.05
Other Purchased Professional and Technical Services	125,000.00	(1,113.00)	123,887.00	98,209.18	25,677.82
Travel	100.00	(76.90)	23.10		23.10
Supplies and Materials		576.90	576.90	576.90	
Total Other Support Services - Students - Special Services	131,800.00	(4,083.50)	127,716.50	100,308.53	27,407.97
Improvement of Instructional Services:					
Salaries of Supervisors	67,500.00	1,800.00	69,300.00	38,700.00	30,600.00
Salaries of Other Professional Services	72,026.00	1,185.00	73,211.00	72,981.00	230.00
Salaries of Secretarial and Clerical Assist.	50,336.00	(0.40)	50,335.60	50,205.55	130.05
Other Salaries	11,130.00	(9,262.30)	1,867.70	17,878.00	1,867.70
Other Purchased Professional and Technical Services	11,600.00	6,278.00	17,878.00	299.25	500.75
Other Purchased Services	1,100.00	(300.00)	800.00	300.00	300.00
Travel		300.00	300.00	699.61	300.00
Supplies and Materials	2,200.00		2,200.00	75.00	1,500.39
Other Objects	1,100.00		1,100.00		1,025.00
Total Improvement of Instructional Services	216,992.00	0.30	216,992.30	180,838.41	36,153.89

(Continued)

TOWNSHIP OF DELANCO SCHOOL DISTRICT

General Fund

Required Supplementary Information
Budgetary Comparison Schedule

For the Fiscal Year Ended June 30, 2016

	Original Budget	Budget Modifications	Final Budget	Actual	Variance Positive (Negative) Final to Actual
EXPENDITURES (CONT'D):					
GENERAL CURRENT EXPENSE (CONT'D):					
Undistributed Expenditures (Cont'd):					
Educational Media Services/School Library:					
Salaries	\$ 59,381.00	\$ 300.00	\$ 59,681.00	\$ 59,381.00	\$ 300.00
Purchased Professional and Technical Services	37,500.00	364.00	37,864.00	37,864.00	
Supplies and Materials	5,800.00	(971.76)	4,828.24	4,828.24	
Total Educational Media Services/School Library	102,681.00	(307.76)	102,373.24	102,073.24	300.00
Instructional Staff Training Services:					
Salaries of Other Professional Staff	600.00		600.00	600.00	
Purchased Professional-Educational Services	5,000.00	(193.44)	4,806.56	4,806.56	
Other Purchased Professional and Technical Services	5,000.00	(98.80)	4,901.20	2,967.00	1,934.20
Travel	3,435.00		3,435.00	1,569.75	1,865.25
Supplies and Materials	5,000.00		5,000.00	26.99	4,973.01
Total Instructional Staff Training Services	18,435.00	307.76	18,742.76	9,970.30	8,772.46
Support Services General Administration:					
Salaries	85,541.00	24,999.64	110,540.64	86,608.80	23,931.84
Legal Services	16,000.00		16,000.00	5,711.44	10,288.56
Audit Fees	18,500.00		18,500.00	15,150.00	3,350.00
Architectural/Engineering Services	1,500.00		1,500.00		1,500.00
Other Purchased Professional Services	14,900.00		14,900.00	8,516.77	6,383.23
Rentals		1,049.04	1,049.04		1,049.04
Communications/Telephone/Postage	20,370.00	(2,577.78)	17,792.22	12,553.95	5,238.27
Travel		2,500.00	2,500.00	2,172.95	327.05
BOE Other Purchased Services	3,000.00		3,000.00	2,808.69	191.31
Other Purchased Services	27,813.00	(11,245.71)	16,567.29	13,938.07	2,629.22
General Supplies	3,500.00	5,406.98	8,906.98	8,894.74	12.24
Miscellaneous Expenditures	4,300.00	(1,083.49)	3,216.51	2,690.45	526.06
BOE Membership Dues and Fees	5,750.00		5,750.00	4,415.60	1,334.40
Total Support Services General Administration	201,174.00	19,048.68	220,222.68	163,461.46	56,761.22

(Continued)

TOWNSHIP OF DELANCO SCHOOL DISTRICT

General Fund
 Required Supplementary Information
 Budgetary Comparison Schedule
 For the Fiscal Year Ended June 30, 2016

	Original Budget	Budget Modifications	Final Budget	Actual	Variance Positive (Negative) Final to Actual
EXPENDITURES (CONTD):					
GENERAL CURRENT EXPENSE (CONTD):					
Undistributed Expenditures (Cont'd):					
Support Services School Administration:					
Salaries of Principals/Assistant Principals	\$ 126,533.00	\$ 8,578.18	\$ 135,111.18	\$ 125,528.00	\$ 9,583.18
Salaries of Secretarial and Clerical Assistants	39,045.00	3,032.25	42,077.25	41,668.42	408.83
Purchased Professional and Technical Services	500.00	3,518.00	3,518.00	3,518.00	
Other Purchased Services	5,200.00	3,198.57	3,698.57	3,661.82	36.75
Supplies and Materials	1,850.00	(1,863.16)	3,336.84	3,336.84	
Other Objects		(179.08)	1,670.92	1,455.00	215.92
Total Support Services School Administration	173,128.00	16,284.76	189,412.76	179,168.08	10,244.68
Central Services:					
Salaries	32,184.00	26,206.28	58,390.28	33,264.45	25,125.83
Other Purchased Professional Services	80,100.00	(88.88)	80,011.12	79,466.00	545.12
Purchased Technical Services	7,440.00	88.88	7,528.88	7,528.88	
Misc. Purchased Services	3,212.00		3,212.00	1,839.93	1,372.07
Supplies and Materials	10,000.00	(1,500.28)	8,499.72	2,597.52	5,902.20
Miscellaneous Expenditures	1,500.00	(706.00)	794.00		794.00
Total Central Services	134,436.00	24,000.00	158,436.00	124,696.78	33,739.22
Information Technology Services:					
Purchased Technical Services	81,045.00	852.25	81,897.25	78,513.39	3,383.86
Supplies and Materials	19,000.00	(3,352.25)	15,647.75	3,204.67	12,443.08
Other Objects	510.00		510.00		510.00
Total - Information Technology Services	100,555.00	(2,500.00)	98,055.00	81,718.06	16,336.94
Required Maintenance for School Facilities:					
Cleaning, Repair and Maintenance Services	58,320.00	56,677.98	114,997.98	109,947.98	5,050.00
General Supplies	20,000.00	(13,551.48)	6,448.52	5,460.28	988.24
Total - Required Maintenance for School Facilities	78,320.00	43,126.50	121,446.50	115,408.26	6,038.24

TOWNSHIP OF DELANCO SCHOOL DISTRICT

General Fund
 Required Supplementary Information
 Budgetary Comparison Schedule
 For the Fiscal Year Ended June 30, 2016

	Original Budget	Budget Modifications	Final Budget	Actual	Variance Positive (Negative) Final to Actual
EXPENDITURES (CONT'D):					
GENERAL CURRENT EXPENSE (CONT'D):					
Undistributed Expenditures (Cont'd):					
Other Operation and Maintenance of Plant Services:					
Salaries	\$ 293,093.00	\$ (3,425.31)	\$ 289,667.69	\$ 273,042.04	\$ 16,625.65
Salaries of Non-Instructional Aides	14,702.00	(14,702.00)			
Cleaning, Repair and Maintenance Services	35,000.00	(17,024.75)	17,975.25	17,275.25	700.00
Other Purchased Property Services	12,000.00	(725.00)	11,275.00	9,980.50	1,294.50
Insurance	13,500.00		13,500.00	12,618.00	882.00
Miscellaneous Purchased Services	30,000.00	(7,249.88)	22,750.12	18,065.86	4,684.26
General Supplies	56,000.00		56,000.00	33,805.41	22,194.59
Energy (Natural Gas)	86,172.00		86,172.00	35,029.06	51,142.94
Energy (Electricity)	176,407.00	(24,000.00)	152,407.00	110,296.33	42,110.67
Energy (Gasoline)	4,000.00		4,000.00		4,000.00
Other Objects	4,025.00		4,025.00	1,227.50	2,797.50
Total - Other Operation and Maintenance of Plant Services	724,899.00	(67,126.94)	657,772.06	511,339.95	146,432.11
Care and Upkeep of Grounds:					
Salaries	6,000.00		6,000.00		6,000.00
Cleaning, Repair and Maintenance Services	10,000.00		10,000.00	5,671.32	4,328.68
General Supplies	6,000.00		6,000.00	2,529.24	3,470.76
Total - Care and Upkeep of Grounds	22,000.00	-	22,000.00	8,200.56	13,799.44
Security:					
Purchased Professional and Technical Services	7,050.00		7,050.00		7,050.00
Cleaning, Repair and Maintenance Services	2,400.00		2,400.00		2,400.00
General Supplies	14,500.00		14,500.00	6,575.60	7,924.40
Total - Security	23,950.00	-	23,950.00	6,575.60	17,374.40
Total - Operation and Maintenance of Plant Services	849,169.00	(24,000.44)	825,168.56	641,524.37	183,644.19

(Continued)

TOWNSHIP OF DELANCO SCHOOL DISTRICT

General Fund

Required Supplementary Information
Budgetary Comparison Schedule

For the Fiscal Year Ended June 30, 2016

	Original Budget	Budget Modifications	Final Budget	Actual	Variance Positive (Negative) Final to Actual
EXPENDITURES (CONTD):					
GENERAL CURRENT EXPENSE (CONTD):					
Undistributed Expenditures (Cont'd):					
Student Transportation Services:					
Salaries for Pupil Transportation (Between Home & School) - Regular	\$ 45,512.00	\$ 3,302.08	\$ 48,814.08	\$ 48,750.58	\$ 63.50
Salaries for Pupil Transportation (Between Home & School) - Special	2,000.00		2,000.00		2,000.00
Salaries for Pupil Transportation (Other than Between Home & School)	8,000.00	(581.12)	7,418.88	784.37	7,418.88
Other Purchased Professional and Technical Services	2,800.00	(2,015.63)	784.37		
Cleaning, Repair and Maintenance Services	11,000.00	(4,274.12)	6,725.88	6,725.88	
Contracted Services - Aid in Lieu of Payments	20,000.00	1,182.36	21,182.36	18,972.36	2,210.00
Contracted Services (Other than Between Home & School) - Vendors		280.00	280.00	280.00	
Contracted Services (Between Home & School) - Joint Agreements	22,000.00	29,361.15	51,361.15	51,361.15	
Contracted Services (Special Education Students) - Joint Agreements	145,000.00	(47,269.66)	97,730.34	92,573.94	5,156.40
Miscellaneous Purchased Services - Transportation	3,000.00	(0.30)	2,999.70	2,569.00	430.70
General Supplies	1,560.00	(1,000.00)	560.00	182.71	377.29
Transportation Supplies	9,000.00	(2,000.00)	7,000.00	1,634.49	5,365.51
Other Objects	500.00		500.00	405.20	94.80
Total Student Transportation Services	270,372.00	(23,015.24)	247,356.76	224,239.68	23,117.08
Unallocated Benefits - Employee Benefits:					
Social Security Contributions	73,500.00	6,000.00	79,500.00	77,080.32	2,419.68
Other Retirement Contributions - PERS	78,730.00	(9,676.95)	69,053.05	63,471.00	5,582.05
Other Retirement Contributions - Regular	7,500.00		7,500.00	5,435.83	2,064.17
Unemployment Compensation	13,000.00	2,778.43	15,778.43	15,778.43	
Workmen's Compensation	49,888.00	(11,086.24)	38,801.76	25,895.77	12,905.99
Health Benefits	968,365.00		968,365.00	909,481.12	58,883.88
Tuition Reimbursement	17,000.00		17,000.00	9,077.30	7,922.70
Other Employee Benefits	52,554.00		52,554.00	46,622.28	5,931.72
Total Unallocated Benefits - Employee Benefits	1,260,537.00	(11,984.76)	1,248,552.24	1,152,842.05	95,710.19
Undistributed Expenditures - Enterprise Funds:					
Amounts to Cover Deficit	7,500.00		7,500.00		7,500.00
On-behalf TPAF Pension Contributions - Normal Cost (non-budgeted)				176,281.00	(176,281.00)
On-behalf TPAF Pension Contributions - Insurance (non-budgeted)				8,781.00	(8,781.00)
On-behalf TPAF Medical Contributions (non-budgeted)				220,359.00	(220,359.00)
Reimbursed TPAF Social Security Contributions (non-budgeted)				182,215.44	(182,215.44)
Total On-behalf Contributions	-	-	-	587,636.44	(587,636.44)

(Continued)

TOWNSHIP OF DELANCO SCHOOL DISTRICT

General Fund

Required Supplementary Information
Budgetary Comparison Schedule

For the Fiscal Year Ended June 30, 2016

	Original Budget	Budget Modifications	Final Budget	Actual	Variance Positive (Negative) Final to Actual
EXPENDITURES (CONT'D):					
GENERAL CURRENT EXPENSE (CONT'D):					
Undistributed Expenditures (Cont'd):					
Total Undistributed Expenses	\$ 3,861,150.00	\$ 53,970.90	\$ 3,915,120.90	\$ 3,944,773.53	\$ (29,652.63)
Total Expenditures - Current Expense	9,343,361.74	(8,162.00)	9,335,199.74	8,564,413.33	770,786.41
CAPITAL OUTLAY:					
Interest Deposit to Capital Reserve	250.00		250.00		250.00
Total - Interest Deposit to Capital Reserve	250.00	-	250.00	-	250.00
Equipment:					
Administrative Information Technology	2,500.00		2,500.00		2,500.00
Operating and Maintenance	29,000.00		29,000.00	25,550.00	3,450.00
Security	11,178.70		11,178.70	8,987.00	2,191.70
Grades 1-5		4,081.00	4,081.00	4,081.00	
Grades 6-8		4,081.00	4,081.00	4,081.00	
Total Equipment	42,678.70	8,162.00	50,840.70	42,699.00	8,141.70
Facilities Acquisition and Construction Services:					
Construction Services	12,000.00		12,000.00		12,000.00
Assessment for Debt Service on SDA Funding	45,886.00		45,886.00	45,886.00	
Total - Facilities Acquisition and Construction Services	57,886.00	-	57,886.00	45,886.00	12,000.00
Total Capital Outlay	100,814.70	8,162.00	108,976.70	88,585.00	20,391.70
Total Expenditures	9,444,176.44	-	9,444,176.44	8,652,998.33	791,178.11
Calculation of Deficiency of Revenues Under Expenditures:					
Excess (Deficiency) of Revenues and Other Financing Sources Over (Under) Expenditures and Other Financing Uses	(1,339,130.44)		(1,339,130.44)	184,072.80	1,523,203.24
Fund Balances, July 1	3,483,960.45		3,483,960.45	3,483,960.45	
Fund Balances, June 30	\$ 2,144,830.01	\$ -	\$ 2,144,830.01	\$ 3,668,033.25	\$ 1,523,203.24

(Continued)

TOWNSHIP OF DELANCO SCHOOL DISTRICT

General Fund
 Required Supplementary Information
 Budgetary Comparison Schedule
 For the Fiscal Year Ended June 30, 2016

	<u>Original Budget</u>	<u>Budget Modifications</u>	<u>Final Budget</u>	<u>Actual</u>	Variance Positive (Negative) <u>Final to Actual</u>
Recapitulation:					
Restricted Fund Balance:					
Capital Reserve				\$ 513,175.84	
Excess Surplus -- Designated for Subsequent Year's Expenditures				1,344,935.78	
Excess Surplus -- Current Year				1,451,114.36	
Assigned Fund Balance:					
For Encumbrances				1,385.05	
Designated for Subsequent Year's Expenditures				37,622.22	
Unassigned Fund Balance				<u>319,800.00</u>	
				3,668,033.25	
Reconciliation to Governmental Funds Statements (GAAP):					
Last State Aid Payment Not Recognized on GAAP Basis				<u>(209,013.00)</u>	
				<u>\$ 3,459,020.25</u>	

TOWNSHIP OF DELANCO SCHOOL DISTRICT
Special Revenue Fund
Required Supplementary Information
Budgetary Comparison Schedule
For the Fiscal Year Ended June 30, 2016

	<u>Original Budget</u>	<u>Budget Transfers</u>	<u>Final Budget</u>	<u>Actual</u>	<u>Variance Positive (Negative) Final to Actual</u>
REVENUES:					
Federal Sources:					
Title I, Part A	\$ 70,000.00	\$ 24,408.00	\$ 94,408.00	\$ 94,408.00	\$ -
Title II, Part A	12,000.00	4,759.00	16,759.00	16,759.00	
I.D.E.A., Part B, Basic	93,737.00	35,742.00	129,479.00	129,479.00	
I.D.E.A., Part B, Preschool Incentive	3,263.00		3,263.00	3,263.00	
Total - Federal Sources	179,000.00	64,909.00	243,909.00	243,909.00	-
Local Sources:					
Parent Teacher Organization		8,000.00	8,000.00	8,000.00	
Total Revenues	\$ 179,000.00	\$ 72,909.00	\$ 251,909.00	\$ 251,909.00	\$ -
EXPENDITURES:					
Instruction:					
Salaries of Teachers	\$ 51,224.68	\$ 17,861.32	\$ 69,086.00	\$ 69,086.00	\$ -
Other Purchased Services	3,263.00		3,263.00	3,263.00	
General Supplies	5,182.08	9,806.92	14,989.00	14,989.00	
Total Instruction	59,669.76	27,668.24	87,338.00	87,338.00	-
Support Services:					
Salaries of Other Professional Staff	2,609.95	910.05	3,520.00	3,520.00	
Personal Services - Employee Benefits	10,983.29	3,829.71	14,813.00	14,813.00	
Purchased Professional and Technical Services	105,109.75	40,252.25	145,362.00	145,362.00	
Other Purchased Services	627.25	248.75	876.00	876.00	
Total Support Services	119,330.24	45,240.76	164,571.00	164,571.00	-
Total Expenditures	\$ 179,000.00	\$ 72,909.00	\$ 251,909.00	\$ 251,909.00	\$ -

REQUIRED SUPPLEMENTARY INFORMATION
PART III

TOWNSHIP OF DELANCO SCHOOL DISTRICT
 Required Supplementary Information
 Schedule of the School District's Proportionate Share of the Net Pension Liability
 Public Employees' Retirement System (PERS)
 Last Three Fiscal Years

	Measurement Date Ending June 30,		
	<u>2015</u>	<u>2014</u>	<u>2013</u>
School District's Proportion of the Net Pension Liability	0.0073826512%	0.0067831124%	0.0071201665%
School District's Proportionate Share of the Net Pension Liability	\$ 1,657,257.00	\$ 1,269,984.00	\$ 1,360,805.00
School District's Covered Payroll (Plan Measurement Period)	\$ 547,856.00	\$ 501,836.00	\$ 522,652.00
School District's Proportionate Share of the Net Pension Liability as a Percentage of it's Covered Payroll	302.50%	253.07%	260.37%
Plan Fiduciary Net Position as a Percentage of the Total Pension Liability	47.93%	52.08%	48.72%

Note: This schedule is presented to illustrate the requirement to show information for 10 years. However, until a full 10-year trend is compiled, this presentation will only include information for those years for which information is available.

TOWNSHIP OF DELANCO SCHOOL DISTRICT
 Required Supplementary Information
 Schedule of the School District's Contributions
 Public Employees' Retirement System (PERS)
 Last Three Fiscal Years

	Fiscal Year Ended June 30,		
	<u>2016</u>	<u>2015</u>	<u>2014</u>
Contractually Required Contribution	\$ 68,167.00	\$ 63,471.00	\$ 55,919.00
Contributions in Relation to the Contractually Required Contribution	<u>(68,167.00)</u>	<u>(63,471.00)</u>	<u>(55,919.00)</u>
Contribution Deficiency (Excess)	<u>\$ -</u>	<u>\$ -</u>	<u>\$ -</u>
School District's Covered Payroll (Fiscal Year)	\$ 527,535.00	\$ 524,035.00	\$ 497,246.00
Contributions as a Percentage of School District's Covered Payroll	12.92%	12.11%	11.25%

Note: This schedule is presented to illustrate the requirement to show information for 10 years. However, until a full 10-year trend is compiled, this presentation will only include information for those years for which information is available.

TOWNSHIP OF DELANCO SCHOOL DISTRICT
 Required Supplementary Information
 Schedule of the School District's Proportionate Share of the Net Pension Liability
 Teachers' Pension and Annuity Fund (TPAF)
 Last Three Fiscal Years

	<u>Measurement Date Ending June 30,</u>		
	<u>2015</u>	<u>2014</u>	<u>2013</u>
School District's Proportion of the Net Pension Liability	0.00%	0.00%	0.00%
State's Proportion of the Net Pension Liability Associated with the School District	<u>100.00%</u>	<u>100.00%</u>	<u>100.00%</u>
	<u>100.00%</u>	<u>100.00%</u>	<u>100.00%</u>
School District's Proportionate Share of the Net Pension Liability	\$ -	\$ -	\$ -
State's Proportionate Share of the Net Pension Liability Associated with the School District	<u>15,689,637.00</u>	<u>13,649,163.00</u>	<u>13,162,373.00</u>
	<u>\$ 15,689,637.00</u>	<u>\$ 13,649,163.00</u>	<u>\$ 13,162,373.00</u>
School District's Covered Payroll (Plan Measurement Period)	\$ 2,798,824.00	\$ 2,918,284.00	\$ 2,886,180.00
School District's Proportionate Share of the Net Pension Liability as a Percentage of it's Covered Payroll	0.00%	0.00%	0.00%
State's Proportionate Share of the Net Pension Liability as a Percentage of it's Covered Payroll	560.58%	467.71%	456.05%
Plan Fiduciary Net Position as a Percentage of the Total Pension Liability	28.71%	33.64%	33.76%

Note: This schedule is presented to illustrate the requirement to show information for 10 years.
 However, until a full 10-year trend is compiled, this presentation will only include information
 for those years for which information is available.

TOWNSHIP OF DELANCO SCHOOL DISTRICT
Required Supplementary Information
Schedule of School District's Contributions
Teachers' Pension and Annuity Fund (TPAF)
Last 10 Fiscal Years

This schedule is not applicable.

The School District is not required to make any contributions towards TPAF.

There is a special funding situation where the State of New Jersey pays 100% of the required contributions.

TOWNSHIP OF DELANCO SCHOOL DISTRICT
Notes to Required Supplementary Information - Part III
For the Fiscal Year Ended June 30, 2016

Public Employees' Retirement System (PERS)

Changes in Benefit Terms - None

Changes in Assumptions - The discount rate changed from 5.39% as of June 30, 2014, to 4.90% as of June 30, 2015, in accordance with Paragraph 44 of GASB Statement No. 67.

Teachers' Pension and Annuity Fund (TPAF)

Changes in Benefit Terms - None

Changes in Assumptions - The discount rate changed from 4.68% as of June 30, 2014, to 4.13% as of June 30, 2015, in accordance with Paragraph 44 of GASB Statement No. 67.

REQUIRED SUPPLEMENTARY INFORMATION
PART IV

TOWNSHIP OF DELANCO SCHOOL DISTRICT
 Required Supplementary Information
 Schedule of Funding Progress for Health Benefits Plan
 For the Fiscal Year Ended June 30, 2016

Actuarial Valuation Date	Actuarial Value of Assets (a)	Actuarial Accrued Liability (AAL) - Entry Age (b)	Unfunded AAL (UAAL) (b-a)	Funded Ratio (a/b)	Covered Payroll (c)	UAAL as a Percentage of Covered Payroll [(b-a)/c]
06/30/16	\$ -	\$ 21,882.58	\$ 21,882.58	\$ -	N/A	N/A
06/30/15	-	25,824.87	25,824.87	-	N/A	N/A
06/30/14	-	19,916.89	19,916.89	-	N/A	N/A

TOWNSHIP OF DELANCO SCHOOL DISTRICT
Notes to Required Supplementary Information - Part IV
For the Fiscal Year Ended June 30, 2016

Other Postemployment Benefits

The information presented in the required supplementary schedule was determined as part of the actuarial valuation at the date indicated. Additional information as of the latest actuarial valuation is as follows:

Valuation Date	June 30, 2016
Actuarial Cost Method	Projected Unit Credit
Amortization Method	Level Dollar
Remaining Amortization Period	17 Years
Asset Valuation Method	Market Value
Actuarial Assumptions:	
Discount Rate	3.0%
Rate of Salary Increases	N/A
Rate of Medical, Prescription AND Dental Inflation	3.0%

For determining the annual required contribution (ARC), the rate of employer contributions to the Plan is composed of the normal cost plus amortization of the unfunded actuarial accrued liability (UAAL), multiplied by the sum of 1 plus the discount rate, or 1.03. The normal cost is a portion of the actuarial present value of plan benefits and expenses which is allocated to a valuation year by the actuarial cost method. The actuarial accrued liability (AAL) is that portion of the present value of projected benefits that will not be paid by future employer normal costs. The difference between this liability and the funds accumulated as of the same date is the unfunded actuarial liability (UAL).

OTHER SUPPLEMENTARY INFORMATION

SPECIAL REVENUE FUND

TOWNSHIP OF DELANCO SCHOOL DISTRICT
 Special Revenue Fund
 Combining Schedule of Revenues and Expenditures - Budgetary Basis
 For the Fiscal Year Ended June 30, 2016

	N.C.L.B.		I.D.E.A. Part B			Parent Teacher Organization
	Total	Title I, Part A	Title II, Part A	Basic	Preschool	
REVENUES:						
Federal Sources	\$ 243,909.00	\$ 94,408.00	\$ 16,759.00	\$ 129,479.00	\$ 3,263.00	\$ -
Local Sources	8,000.00					8,000.00
Total Revenues	\$ 251,909.00	\$ 94,408.00	\$ 16,759.00	\$ 129,479.00	\$ 3,263.00	\$ 8,000.00
EXPENDITURES:						
Instruction:						
Salaries of Teachers	\$ 69,086.00	\$ 69,086.00	\$ -	\$ -	\$ -	\$ -
Other Purchased Services	3,263.00				3,263.00	
General Supplies	14,989.00	6,989.00				8,000.00
Total Instruction	\$ 87,338.00	\$ 76,075.00	\$ -	\$ -	\$ 3,263.00	\$ 8,000.00
Support Services:						
Salaries of Other Professional Staff	3,520.00	3,520.00				
Personal Services - Employee Benefits	14,813.00	14,813.00				
Purchased Professional and Technical Services	145,362.00		15,883.00	129,479.00		
Other Purchased Services	876.00	876.00				
Total Support Services	\$ 164,571.00	\$ 18,333.00	\$ 16,759.00	\$ 129,479.00	\$ -	\$ -
Total Expenditures	\$ 251,909.00	\$ 94,408.00	\$ 16,759.00	\$ 129,479.00	\$ 3,263.00	\$ 8,000.00

PROPRIETARY FUNDS

TOWNSHIP OF DELANCO SCHOOL DISTRICT
Proprietary Funds
Business-Type Activities - Enterprise Funds
Combining Statement of Net Position
June 30, 2016

	<u>Food Service</u>	<u>Ex Care Program</u>	<u>Total</u>
ASSETS:			
Current Assets:			
Cash and Cash Equivalents	\$ 5,327.21	\$ 22,170.42	\$ 27,497.63
Accounts Receivable:			
State	77.94		77.94
Federal	3,845.98		3,845.98
Other	43.10	2,214.82	2,257.92
Inventories	3,430.35		3,430.35
Total Current Assets	<u>12,724.58</u>	<u>24,385.24</u>	<u>37,109.82</u>
Noncurrent Assets:			
Equipment	178,961.00		178,961.00
Less Accumulated Depreciation	(117,440.61)		(117,440.61)
Total Capital Assets (Net of Accumulated Depreciation)	<u>61,520.39</u>	<u>-</u>	<u>61,520.39</u>
Total Noncurrent Assets	<u>61,520.39</u>	<u>-</u>	<u>61,520.39</u>
Total Assets	<u>74,244.97</u>	<u>24,385.24</u>	<u>98,630.21</u>
LIABILITIES:			
Current Liabilities:			
Accounts Payable	526.96		526.96
Unearned Revenue	1,552.49	1,074.17	2,626.66
Total Liabilities	<u>2,079.45</u>	<u>1,074.17</u>	<u>3,153.62</u>
NET POSITION:			
Net Investment in Capital Assets	61,520.39		61,520.39
Unrestricted	10,645.13	23,311.07	33,956.20
Total Net Position	<u>\$ 72,165.52</u>	<u>\$ 23,311.07</u>	<u>\$ 95,476.59</u>

TOWNSHIP OF DELANCO SCHOOL DISTRICT
 Proprietary Funds
 Business-Type Activities - Enterprise Funds
 Combining Statement of Revenues, Expenses and Changes in Fund Net Position
 For the Fiscal Year Ended June 30, 2016

	<u>Food Service</u>	<u>Ex Care Program</u>	<u>Total</u>
OPERATING REVENUES:			
Charges for Services:			
Daily Sales - Reimbursable Programs:			
School Lunch Program	\$ 46,889.80	\$ -	\$ 46,889.80
School Breakfast Program	2,441.60		2,441.60
Daily Sales - Non-Reimbursable Programs	20,416.35		20,416.35
Community Service Activities		97,920.97	97,920.97
	<hr/>	<hr/>	<hr/>
Total Operating Revenues	69,747.75	97,920.97	167,668.72
OPERATING EXPENSES:			
Direct Expenses	4,916.96		4,916.96
Cost of Sales - Reimbursable Programs	50,360.02		50,360.02
Cost of Sales - Non-Reimbursable Programs	7,648.00		7,648.00
Management Fees	13,259.82		13,259.82
Salaries	77,295.81	46,633.14	123,928.95
Benefits		3,567.47	3,567.47
Purchased Professional Services		2,500.00	2,500.00
Supplies and Materials	3,579.46	4,292.64	7,872.10
Rent		53,000.00	53,000.00
Depreciation	10,253.40		10,253.40
	<hr/>	<hr/>	<hr/>
Total Operating Expenses	167,313.47	109,993.25	277,306.72
Operating Income (Loss)	<hr/> (97,565.72)	<hr/> (12,072.28)	<hr/> (109,638.00)
NONOPERATING REVENUES (EXPENSES):			
State Sources:			
State School Lunch Program	1,730.25		1,730.25
Federal Sources:			
National School Lunch Program	65,576.13		65,576.13
National School PB Lunch Program	2,133.42		2,133.42
National School Breakfast Program	11,151.64		11,151.64
Food Distribution Program	13,924.26		13,924.26
Interest Revenue	105.40	157.45	262.85
	<hr/>	<hr/>	<hr/>
Total Nonoperating Revenues (Expenses)	94,621.10	157.45	94,778.55
Change in Net Position	(2,944.62)	(11,914.83)	(14,859.45)
Net Position -- July 1	75,110.14	35,225.90	110,336.04
Net Position -- June 30	<hr/> <hr/> \$ 72,165.52	<hr/> <hr/> \$ 23,311.07	<hr/> <hr/> \$ 95,476.59

TOWNSHIP OF DELANCO SCHOOL DISTRICT
Proprietary Funds
Business-Type Activities - Enterprise Funds
Combining Statement of Cash Flows
For the Fiscal Year Ended June 30, 2016

	<u>Food Service</u>	<u>Ex Care Program</u>	<u>Total</u>
CASH FLOWS FROM OPERATING ACTIVITIES:			
Receipts from Customers	\$ 71,257.14	\$ 97,340.57	\$ 168,597.71
Payments to Management Company	(147,932.40)		(147,932.40)
Payments to Employees		(46,633.14)	(46,633.14)
Payments for Employee Benefits		(3,567.47)	(3,567.47)
Payments for Professional Services		(2,500.00)	(2,500.00)
Payments for Rent		(53,000.00)	(53,000.00)
Payments to Suppliers	<u>(14,547.80)</u>	<u>(4,292.64)</u>	<u>(18,840.44)</u>
Net Cash Provided by (Used for) Operating Activities	<u>(91,223.06)</u>	<u>(12,652.68)</u>	<u>(103,875.74)</u>
CASH FLOWS FROM NON-CAPITAL FINANCING ACTIVITIES:			
State Sources	1,749.51		1,749.51
Federal Sources	<u>93,600.44</u>		<u>93,600.44</u>
Net Cash Provided by (Used for) Non-Capital Financing Activities	<u>95,349.95</u>	<u>-</u>	<u>95,349.95</u>
CASH FLOWS FROM INVESTING ACTIVITIES:			
Interest Revenue	<u>105.40</u>	<u>157.45</u>	<u>262.85</u>
Net Increase (Decrease) in Cash and Cash Equivalents	4,232.29	(12,495.23)	(8,262.94)
Cash and Cash Equivalents -- July 1	<u>1,094.92</u>	<u>34,665.65</u>	<u>35,760.57</u>
Cash and Cash Equivalents -- June 30	<u>\$ 5,327.21</u>	<u>\$ 22,170.42</u>	<u>\$ 27,497.63</u>
Reconciliation of Operating Income (Loss) to Net Cash Provided (Used) by Operating Activities:			
Operating Income (Loss)	\$ (97,565.72)	\$ (12,072.28)	\$ (109,638.00)
Adjustments to Reconcile Operating Income (Loss) to Net Cash Provided by (Used for) Operating Activities:			
Depreciation and Net Amortization	10,253.40		10,253.40
(Increase) Decrease in Accounts Receivable	(43.10)	(1,161.57)	(1,204.67)
(Increase) Decrease in Inventories	(896.56)		(896.56)
Increase (Decrease) in Unearned Revenue	1,552.49	581.17	2,133.66
Increase (Decrease) in Accounts Payable	<u>(4,523.57)</u>		<u>(4,523.57)</u>
Total Adjustments	<u>6,342.66</u>	<u>(580.40)</u>	<u>5,762.26</u>
Net Cash Provided by (Used for) Operating Activities	<u>\$ (91,223.06)</u>	<u>\$ (12,652.68)</u>	<u>\$ (103,875.74)</u>

TOWNSHIP OF DELANCO SCHOOL DISTRICT
Proprietary Funds
Governmental Activities - Internal Service Fund
Statement of Net Position
June 30, 2016

	Substitute <u>Calling</u>
ASSETS:	
Current Assets:	
Cash and Cash Equivalents	\$ <u>637.87</u>
LIABILITIES:	
Current Liabilities:	
Unearned Revenue	<u>637.87</u>
NET POSITION:	
Unrestricted	<u>-</u>
Total Net Position	<u><u>\$ -</u></u>

TOWNSHIP OF DELANCO SCHOOL DISTRICT
 Proprietary Funds
 Governmental Activities - Internal Service Fund
 Statement of Revenues, Expenses and Changes in Fund Net Position
 For the Fiscal Year Ended June 30, 2016

	<u>Substitute Calling</u>
OPERATING REVENUES:	
Charges for Services:	
Substitute Calling Fees from Other LEA's Within the State	\$ 9,085.23
Total Operating Revenues	<u>9,085.23</u>
OPERATING EXPENSES:	
Salaries	7,659.37
Benefits	670.87
Purchased Professional Services	655.40
Supplies and Materials	<u>115.24</u>
Total Operating Expenses	<u>9,100.88</u>
Operating Income / (Loss)	<u>(15.65)</u>
NONOPERATING REVENUES (EXPENSES):	
Interest Revenue	<u>15.65</u>
Total Nonoperating Revenues (Expenses)	<u>15.65</u>
Change in Net Position	-
Net Position -- July 1	<u>-</u>
Net Position -- June 30	<u><u>\$ -</u></u>

TOWNSHIP OF DELANCO SCHOOL DISTRICT
 Proprietary Funds
 Governmental Activities - Internal Service Fund
 Statement of Cash Flows
 For the Fiscal Year Ended June 30, 2016

	<u>Substitute Calling</u>
CASH FLOWS FROM OPERATING ACTIVITIES:	
Receipts from Customers	\$ 9,170.00
Payments to Employees	(7,659.37)
Payments for Employee Benefits	(670.87)
Payments for Professional Services	(655.40)
Payments to Suppliers	<u>(115.24)</u>
Net Cash Provided by (Used for) Operating Activities	<u>69.12</u>
CASH FLOWS FROM INVESTING ACTIVITIES:	
Interest Revenue	<u>15.65</u>
Net Increase (Decrease) in Cash and Cash Equivalents	84.77
Cash and Cash Equivalents -- July 1	<u>553.10</u>
Cash and Cash Equivalents -- June 30	<u><u>\$ 637.87</u></u>
Reconciliation of Operating Income (Loss) to Net Cash Provided (Used)	
by Operating Activities:	
Operating Income (Loss)	\$ (15.65)
Adjustments to Reconcile Operating Income (Loss) to Net Cash	
Provided by (Used for) Operating Activities:	
Increase (Decrease) in Unearned Revenue	<u>84.77</u>
Net Cash Provided by (Used for) Operating Activities	<u><u>\$ 69.12</u></u>

FIDUCIARY FUNDS

TOWNSHIP OF DELANCO SCHOOL DISTRICT
 Fiduciary Funds
 Combining Statement of Fiduciary Net Position
 June 30, 2016

	Private-Purpose Trust Fund	Agency Funds		Total
	Scholarship Fund	Student Activity	Payroll	
ASSETS:				
Cash and Cash Equivalents	\$ 2,373.91	\$ 20,164.77	\$ 4,475.16	\$ 27,013.84
Total Assets	<u>2,373.91</u>	<u>\$ 20,164.77</u>	<u>\$ 4,475.16</u>	<u>27,013.84</u>
LIABILITIES:				
Interfund Accounts Payable:				
Due General Fund		\$ -	\$ 49.37	49.37
Payroll Deductions Payable			4,425.79	4,425.79
Payable to Student Groups		<u>20,164.77</u>		<u>20,164.77</u>
Total Liabilities	<u>-</u>	<u>\$ 20,164.77</u>	<u>\$ 4,475.16</u>	<u>24,639.93</u>
NET POSITION:				
Held in Trust for Other Purposes	<u>\$ 2,373.91</u>			<u>\$ 2,373.91</u>

TOWNSHIP OF DELANCO SCHOOL DISTRICT
 Fiduciary Funds
 Statement of Changes in Fiduciary Net Position
 For the Fiscal Year Ended June 30, 2016

	<u>Private-Purpose Trust Fund</u>
	<u>Scholarship Fund</u>
ADDITIONS:	
Investment Earnings:	
Interest	\$ 2.39
DEDUCTIONS:	
Scholarship Awards	<u>50.00</u>
Change in Net Position	(47.61)
Net Position -- July 1	<u>2,421.52</u>
Net Position -- June 30	<u><u>\$ 2,373.91</u></u>

TOWNSHIP OF DELANCO SCHOOL DISTRICT
 Fiduciary Funds
 Student Activity Agency Fund Schedule of Receipts and Disbursements
 For the Fiscal Year Ended June 30, 2016

	<u>Balance</u> <u>June 30, 2015</u>	<u>Cash</u> <u>Receipts</u>	<u>Cash</u> <u>Disbursements</u>	<u>Balance</u> <u>June 30, 2016</u>
MIDDLE SCHOOL:				
Walnut Ave School	\$ 17,709.94	\$ 24,144.73	\$ 25,618.19	\$ 16,236.48
ELEMENTARY SCHOOL:				
Pearson School	<u>2,327.04</u>	<u>4,315.50</u>	<u>2,714.25</u>	<u>3,928.29</u>
Total All Schools	<u><u>\$ 20,036.98</u></u>	<u><u>\$ 28,460.23</u></u>	<u><u>\$ 28,332.44</u></u>	<u><u>\$ 20,164.77</u></u>

TOWNSHIP OF DELANCO SCHOOL DISTRICT
 Fiduciary Funds
 Payroll and Agency Fund Schedule of Receipts and Disbursements
 For the Fiscal Year Ended June 30, 2016

	<u>Balance June 30, 2015</u>	<u>Additions</u>	<u>Deletions</u>	<u>Balance June 30, 2016</u>
ASSETS:				
Cash and Cash Equivalents	\$ 1,579.09	\$ 6,285,177.74	\$ 6,282,281.67	\$ 4,475.16
	<u>\$ 1,579.09</u>	<u>\$ 6,285,177.74</u>	<u>\$ 6,282,281.67</u>	<u>\$ 4,475.16</u>
LIABILITIES:				
Payroll Deductions and Withholdings	\$ 1,428.65	\$ 1,679,525.88	\$ 1,676,528.74	\$ 4,425.79
Net Payroll		2,303,551.37	2,303,551.37	
Contra		2,301,820.47	2,301,820.47	
Interfund Accounts Payable:				
Due General Fund	<u>150.44</u>	<u>280.02</u>	<u>381.09</u>	<u>49.37</u>
Total Liabilities	<u>\$ 1,579.09</u>	<u>\$ 6,285,177.74</u>	<u>\$ 6,282,281.67</u>	<u>\$ 4,475.16</u>

LONG-TERM DEBT

TOWNSHIP OF DELANCO SCHOOL DISTRICT
 Schedule of Serial Bonds
 For the Fiscal Year Ended June 30, 2016

Issue	Date of Issue	Amount of Issue	Annual Maturities		Interest Rate	Balance June 30, 2015	Issued	Disbursed	Balance June 30, 2016
			Date	Amount					
School District Bonds -- Series 2005	05/01/05	\$ 6,761,000.00	08/01/15	\$ 220,000.00	4.125%	\$ 220,000.00	\$ -	\$ 220,000.00	\$ -
School District Refunding Bonds -- Series 2013	04/24/13	5,600,000.00	08/01/16	275,000.00	3.000%				
			08/01/17	375,000.00	3.000%				
			08/01/18	390,000.00	3.000%				
			08/01/19	410,000.00	3.000%				
			08/01/20	435,000.00	3.000%				
			08/01/21	455,000.00	5.000%				
			08/01/22	480,000.00	2.000%				
			08/01/23	490,000.00	2.125%				
			08/01/24	500,000.00	2.250%				
			08/01/25	520,000.00	3.000%				
			08/01/26	555,000.00	3.000%				
			08/01/27	570,000.00	3.000%	5,490,000.00		35,000.00	5,455,000.00
						<u>\$ 5,710,000.00</u>	<u>\$ -</u>	<u>\$ 255,000.00</u>	<u>\$ 5,455,000.00</u>

TOWNSHIP OF DELANCO SCHOOL DISTRICT
 Debt Service Fund
 Budgetary Comparison Schedule
 For the Fiscal Year Ended June 30, 2016

	<u>Original Budget</u>	<u>Budget Transfers</u>	<u>Final Budget</u>	<u>Actual</u>	<u>Variance Positive (Negative) Final to Actual</u>
REVENUES:					
Local Sources:					
Local Tax Levy	\$ 419,800.00	-	\$ 419,800.00	\$ 419,800.00	\$ -
Miscellaneous				20.10	(20.10)
Total Revenues	<u>419,800.00</u>	<u>-</u>	<u>419,800.00</u>	<u>419,820.10</u>	<u>(20.10)</u>
EXPENDITURES:					
Regular Debt Service:					
Interest	164,801.00		164,801.00	164,800.10	0.90
Redemption of Principal	255,000.00		255,000.00	255,000.00	
Total Regular Debt Service	<u>419,801.00</u>	<u>-</u>	<u>419,801.00</u>	<u>419,800.10</u>	<u>0.90</u>
Total Expenditures	<u>419,801.00</u>	<u>-</u>	<u>419,801.00</u>	<u>419,800.10</u>	<u>0.90</u>
Excess (Deficiency) of Revenues Over (Under) Expenditures	<u>(1.00)</u>	<u>-</u>	<u>(1.00)</u>	<u>20.00</u>	<u>(21.00)</u>
Fund Balance, July 1	<u>5,534.43</u>	<u>-</u>	<u>5,534.43</u>	<u>5,534.43</u>	<u>-</u>
Fund Balance, June 30	<u>\$ 5,533.43</u>	<u>\$ -</u>	<u>\$ 5,533.43</u>	<u>\$ 5,554.43</u>	<u>\$ (21.00)</u>
Recapitulation:					
Restricted Fund Balance -- Designated for Subsequent Year's Expenditures			<u>\$ 5,554.43</u>	<u>\$ 5,554.43</u>	

STATISTICAL SECTION

Financial Trends Information

Financial trends information is intended to assist the user in understanding and assessing how the School District's financial position has changed over time. Please refer to the following exhibits for a historical view of the School District's financial performance.

TOWNSHIP OF DELANCO SCHOOL DISTRICT
 Net Position by Component
 Last Ten Fiscal Years (Accrual Basis of Accounting)
Unaudited

	Fiscal Year Ended June 30,									
	2016	2015	2014	2013	2012	2011	2010	2009	2008	2007
Governmental Activities:										
Net Investment in Capital Assets	\$ 8,185,833.35	\$ 8,204,662.65	\$ 8,256,506.31	\$ 8,256,626.64	\$ 8,642,216.90	\$ 8,756,189.55	\$ 8,935,363.98	\$ 9,116,732.86	\$ 9,838,124.51	\$ 9,861,899.11
Restricted	3,314,780.41	3,201,872.88	2,762,451.76	1,874,636.69	1,855,645.29	951,358.55	702,688.48	922,047.20	979,109.69	1,135,298.68
Unrestricted (Deficit)	(1,609,294.44)	(1,625,810.22)	(326,487.58)	57,294.37	(11,724.81)	(4,976.16)	12,442.95	406,511.01	(38,616.14)	(24,918.24)
Total Governmental Activities Net Position	\$ 9,891,319.32	\$ 9,780,725.31	\$ 10,692,470.49	\$ 10,188,557.70	\$ 10,486,137.38	\$ 9,702,571.94	\$ 9,650,495.41	\$ 10,445,291.07	\$ 10,778,618.06	\$ 10,972,279.55
Business-type Activities:										
Net Investment in Capital Assets	\$ 61,520.39	\$ 71,773.79	\$ 82,142.55	\$ 92,626.69	\$ 103,110.82	\$ 113,594.95	\$ 125,435.27	\$ 138,631.80	\$ 157,428.32	\$ 11,223.81
Unrestricted	33,956.20	38,562.25	26,785.09	27,577.54	25,268.65	22,559.90	17,004.58	14,851.87	8,588.87	5,749.30
Total Business-type Activities Net Position	\$ 95,476.59	\$ 110,336.04	\$ 108,927.64	\$ 120,204.23	\$ 128,379.47	\$ 136,154.85	\$ 142,439.85	\$ 153,483.67	\$ 166,017.19	\$ 16,973.11
Government-wide:										
Net Investment in Capital Assets	\$ 8,247,353.74	\$ 8,276,436.44	\$ 8,338,648.86	\$ 8,349,253.33	\$ 8,745,327.72	\$ 8,869,784.50	\$ 9,060,799.25	\$ 9,255,364.66	\$ 9,995,552.83	\$ 9,873,122.92
Restricted	3,314,780.41	3,201,872.88	2,762,451.76	1,874,636.69	1,855,645.29	951,358.55	702,688.48	922,047.20	979,109.69	1,135,298.68
Unrestricted (Deficit)	(1,575,338.24)	(1,587,247.97)	(299,702.49)	84,871.91	13,543.84	17,583.74	29,447.53	421,362.88	(30,027.27)	(19,168.94)
Total Government-wide Net Position	\$ 9,986,795.91	\$ 9,891,061.35	\$ 10,801,398.13	\$ 10,308,761.93	\$ 10,614,516.85	\$ 9,838,726.79	\$ 9,792,935.26	\$ 10,598,774.74	\$ 10,944,635.25	\$ 10,989,252.66

Source: Exhibit A-1

For the fiscal year ended June 30, 2015, the School District adopted GASBS No's. 68 and 71, which required the School District to record its proportionate share of the net pension liability and related deferred outflows and inflows of resources in the government-wide financial statements. Balances prior to June 30, 2015 are shown as originally reported and have not been restated for this adoption.

TOWNSHIP OF DELANCO SCHOOL DISTRICT
Changes in Net Position
Last Ten Fiscal Years (Accrual Basis of Accounting)
Unaudited

	2016	2015	2014	2013	2012	2011	2010	2009	2008	2007
Fiscal Year Ended June 30.										
Expenses:										
Governmental Activities:										
Instruction:										
Regular	\$ 2,239,306.12	\$ 2,126,654.93	\$ 2,196,666.52	\$ 2,519,755.41	\$ 2,403,744.01	\$ 2,438,176.51	\$ 2,498,349.20	\$ 2,829,794.23	\$ 2,157,409.12	\$ 2,045,518.93
Special Education	582,599.32	556,872.92	529,678.57	678,056.55	601,499.35	653,469.00	721,804.01	560,948.23	796,520.14	541,284.41
Other Special Education	57,697.64	56,758.75	55,889.25	63,336.37	53,464.74	147,763.41	117,076.39	119,587.46	56,710.77	41,610.73
Other Instruction	33,820.02	33,145.18	29,903.89	34,484.55	34,046.01	37,206.20	76,069.47	97,933.72	93,531.17	99,786.41
Support Services:										
Tuition	2,088,964.89	2,142,259.49	2,272,329.24	2,636,234.48	2,261,169.17	2,562,492.24	2,326,835.16	1,875,992.43	1,802,135.99	1,861,389.68
Student and Instruction Related Services	954,057.61	923,882.82	829,636.78	900,880.19	902,208.78	897,656.94	872,313.01	890,673.06	689,179.84	752,096.60
School Administrative Services	184,326.67	184,765.65	139,118.83	172,702.10	169,325.54	179,778.51	172,750.43	147,044.42	163,496.63	137,113.02
General and Business Administrative Services	369,876.30	373,402.68	335,956.70	324,721.53	314,146.94	343,138.57	454,455.39	414,979.20	461,633.13	417,905.11
Plant Operations and Maintenance	654,691.89	557,603.18	573,507.65	653,238.02	597,542.37	650,754.21	768,245.36	720,984.67	750,491.17	690,155.63
Pupil Transportation	232,961.99	205,793.06	161,467.41	304,423.20	244,161.74	190,287.20	302,590.41	174,497.13	174,497.13	213,411.08
Unallocated Benefits	2,578,535.68	2,169,768.16	1,416,679.88	541,090.14	427,896.10	363,956.25	369,968.48	364,921.58	556,507.23	509,477.64
Interest on Long-term Debt	206,158.97	215,375.95	202,714.05	659,784.89	284,484.02	285,724.04	278,185.77	280,857.52	272,575.83	167,885.65
Transfer to Charter School						3,861.00				
Unallocated Depreciation										29,817.92
Total Governmental Activities Expenses	10,182,997.10	9,546,282.77	8,743,548.77	9,488,707.43	8,293,688.77	8,754,264.08	8,958,643.08	8,478,339.13	7,974,688.15	7,507,452.81
Business-type Activities:										
Food Service	167,313.47	164,519.15	170,830.70	166,948.52	162,660.22	160,124.54	160,164.92	145,909.21	176,601.49	115,416.56
Other	109,993.25	107,559.11	110,169.59	99,599.14	90,662.80	83,770.52				
Total Business-type Activities Expense	277,306.72	272,078.26	281,000.29	266,547.66	253,323.02	243,895.06	160,164.92	145,909.21	176,601.49	115,416.56
Total Government-wide Expenses	\$ 10,460,303.82	\$ 9,818,361.03	\$ 9,024,549.06	\$ 9,755,255.09	\$ 8,547,011.79	\$ 8,998,159.14	\$ 9,118,808.00	\$ 8,624,248.34	\$ 8,151,289.64	\$ 7,622,869.37
Program Revenues:										
Governmental Activities:										
Operating Grants and Contributions	\$ 1,612,477.44	\$ 1,383,832.77	\$ 739,877.32	\$ 779,518.40	\$ 661,527.60	\$ 643,845.40	\$ 678,431.94	\$ 594,189.51	\$ 836,708.16	\$ 650,713.33
Charges for Services	64,349.23	13,299.09	22,177.70	7,121.17	6,856.11	6,294.09	8,997.95	14,064.00		
Total Governmental Activities Program Revenues	1,676,826.67	1,397,131.86	762,055.02	786,639.57	668,383.71	650,139.49	687,429.89	608,253.51	836,708.16	650,713.33
Business-type activities:										
Charges for services										
Food service	69,747.75	63,933.51	68,268.57	68,130.56	69,986.07	74,670.83	81,654.10	81,223.50	83,068.33	69,034.91
Other	97,920.97	119,355.75	109,839.86	104,841.23	99,590.10	92,878.83			191,000.00	15,000.00
Capital Grants and Contributions										
Operating Grants and Contributions	94,515.70	90,104.86	85,981.54	85,342.88	75,940.75	69,669.64	67,312.03	51,914.25	51,232.87	33,398.06
Total Business-type Activities Program Revenues	262,184.42	273,394.12	264,089.97	258,314.67	245,526.92	237,219.30	148,966.13	133,137.75	325,301.20	117,432.97
Total Government-wide Program Revenues	\$ 1,939,011.09	\$ 1,670,525.98	\$ 1,026,144.99	\$ 1,044,954.24	\$ 913,910.63	\$ 887,358.79	\$ 836,396.02	\$ 741,391.26	\$ 1,162,009.36	\$ 768,146.30

TOWNSHIP OF DELANCO SCHOOL DISTRICT
 Changes in Net Position
 Last Ten Fiscal Years (Accrual Basis of Accounting)
Unaudited

	Fiscal Year Ended June 30,									
	2016	2015	2014	2013	2012	2011	2010	2009	2008	2007
Net (Expense)/Revenue:										
Governmental Activities	\$ (8,506,170.43)	\$ (8,149,150.91)	\$ (7,981,493.75)	\$ (8,702,067.86)	\$ (7,625,305.06)	\$ (8,104,124.59)	\$ (8,271,213.19)	\$ (7,870,085.62)	\$ (7,137,979.99)	\$ (6,856,739.48)
Business-type Activities	(15,122.30)	1,315.86	(16,910.32)	(8,232.99)	(7,796.10)	(6,675.76)	(11,198.79)	(12,771.46)	148,699.71	2,016.41
Total Government-wide Net Expense	\$ (8,521,292.73)	\$ (8,147,835.05)	\$ (7,998,404.07)	\$ (8,710,300.85)	\$ (7,633,101.16)	\$ (8,110,800.35)	\$ (8,282,411.98)	\$ (7,882,857.08)	\$ (6,989,280.28)	\$ (6,854,723.07)
General Revenues and Other Changes in Net Position:										
Governmental Activities:										
Property Taxes Levied for General Purposes, Net	\$ 5,560,840.00	\$ 5,597,301.00	\$ 5,487,550.00	\$ 5,434,251.00	\$ 5,529,152.00	\$ 5,420,737.00	\$ 4,999,989.00	\$ 4,796,752.00	\$ 4,688,783.00	\$ 4,493,107.00
Taxes Levied for Debt Service	419,800.00	383,339.00	436,592.00	421,108.00	370,277.00	387,209.00	396,112.00	347,112.00	137,499.00	333,175.00
Unrestricted Grants and Contributions	2,550,213.00	2,537,911.00	2,468,668.00	2,447,834.00	2,428,808.52	2,252,842.48	1,936,458.00	2,326,435.60	2,196,494.00	2,096,696.00
Investment Earnings	6,103.77	3,409.86	3,052.57	2,700.21	1,148.28	20,674.08	32,648.12	40,576.04	110,260.44	87,949.29
Other	79,807.67	76,249.87	97,107.29	98,594.97	79,484.70	74,742.85	21,974.31	25,882.99	7,282.06	80,219.14
Assets Acquired Under Capital Lease							89,236.00			31,578.39
Cancellation of Special Revenue Appropriations						(4.29)	0.10			
Transfers			(5,563.32)						(196,000.00)	(15,000.00)
Total Governmental Activities	8,616,764.44	8,598,210.73	8,485,406.54	8,404,488.18	8,408,870.50	8,156,201.12	7,476,417.53	7,536,758.63	6,944,318.50	7,107,724.82
Business-type Activities:										
Investment Earnings	262.85	92.54	70.41	57.75	20.72	390.76	154.97	237.94	344.37	420.98
Transfers			5,563.32							
Total Business-type Activities	262.85	92.54	5,633.73	57.75	20.72	390.76	154.97	237.94	344.37	420.98
Total Government-wide	\$ 8,617,027.29	\$ 8,598,303.27	\$ 8,491,040.27	\$ 8,404,545.93	\$ 8,408,891.22	\$ 8,156,591.88	\$ 7,476,572.50	\$ 7,536,996.57	\$ 6,944,662.87	\$ 7,108,145.80
Change in Position:										
Governmental Activities	\$ 110,594.01	\$ 449,059.82	\$ 503,912.79	\$ (297,579.68)	\$ 783,565.44	\$ 52,076.53	\$ (794,795.66)	\$ (333,326.99)	\$ (193,661.49)	\$ 250,985.34
Business-type Activities	(14,859.45)	1,408.40	(11,276.59)	(8,175.24)	(7,775.38)	(6,285.00)	(11,043.82)	(12,533.52)	149,044.08	2,437.39
Total Government-wide	\$ 95,734.56	\$ 450,468.22	\$ 492,636.20	\$ (305,754.92)	\$ 775,790.06	\$ 45,791.53	\$ (805,839.48)	\$ (345,860.51)	\$ (44,617.41)	\$ 253,422.73

Source: Exhibit A-2

For the fiscal year ended June 30, 2015, the School District adopted GASBS No's. 68 and 71, which required the School District to record its proportionate share of the net pension liability and related deferred outflows and inflows of resources in the government-wide financial statements. Balances prior to June 30, 2015 are shown as originally reported and have not been restated for this adoption.

TOWNSHIP OF DELANCO SCHOOL DISTRICT
Fund Balances, Governmental Funds
Last Ten Fiscal Years (Modified Accrual Basis of Accounting)
Unaudited

	Fiscal Year Ended June 30,									
	2016	2015	2014	2013	2012	2011	2010	2009	2008	2007
General Fund:										
Reserved	\$ -	\$ -	\$ -	\$ -	\$ -	\$ -	\$ 683,690.65	\$ 1,000,677.89	\$ 878,922.17	\$ 808,737.39
Unreserved	3,309,225.98	3,164,899.85	2,682,673.67	1,934,328.61	1,734,116.27	843,547.37	254,768.12	485,932.21	362,615.58	254,027.90
Restricted	39,007.27	31,438.60	58,834.65	8,070.00	118,921.20	54,189.93				
Assigned	110,787.00	75,851.00	34,245.00	303,954.00	251,044.00	251,392.00				
Unassigned										
Total General Fund	\$ 3,459,020.25	\$ 3,272,189.45	\$ 2,775,753.32	\$ 2,246,352.61	\$ 2,104,081.47	\$ 1,149,129.30	\$ 938,458.77	\$ 1,486,610.10	\$ 1,241,537.75	\$ 1,062,765.29
All Other Governmental Funds:										
Reserved	\$ -	\$ -	\$ -	\$ -	\$ -	\$ -	\$ 32,850.00	\$ 19,592.79	\$ 50,574.99	\$ 412,727.63
Unreserved, Reported in:										
Special Revenue Fund									(3,306.40)	(1,181.40)
Capital Projects Fund							55,377.60	159,349.44	321,170.81	402,114.46
Debt Service Fund							29,917.73	4,588.99	5,488.33	231,649.24
Restricted:										
Capital Projects Fund	5,554.43	5,534.43	25,824.74	1.66	2,805.16	2,771.50				
Debt Service Fund						50,267.57				
Total All Other Governmental Funds	\$ 5,554.43	\$ 5,534.43	\$ 25,824.74	\$ 1.66	\$ 2,805.16	\$ 53,039.07	\$ 118,145.33	\$ 183,531.22	\$ 373,927.73	\$ 1,045,309.93

In accordance with GASB 54, effective for the fiscal year ended June 30, 2011, the description and terminology utilized to identify fund balance was changed. See the notes to the financial statements.

Source: Exhibit B-1

TOWNSHIP OF DELANCO SCHOOL DISTRICT
 Changes in Fund Balances, Governmental Funds
 Last Ten Fiscal Years (Modified Accrual Basis of Accounting)
Unaudited

	Fiscal Year Ended June 30,									
	2016	2015	2014	2013	2012	2011	2010	2009	2008	2007
REVENUES:										
Tax Levy	\$ 5,980,640.00	\$ 5,980,640.00	\$ 5,924,142.00	\$ 5,855,359.00	\$ 5,899,429.00	\$ 5,807,946.00	\$ 5,396,101.00	\$ 5,143,864.00	\$ 4,826,282.00	\$ 4,826,282.00
Other Local Revenue	141,159.79	84,060.38	114,295.51	101,290.44	80,631.43	95,362.72	57,538.85	80,523.03	110,260.44	168,168.43
State Sources	3,145,849.44	3,064,859.77	2,929,594.65	2,988,924.14	2,772,698.10	2,611,812.25	1,920,865.48	2,694,863.58	2,817,004.23	2,630,836.64
Federal Sources	243,909.00	256,637.00	276,950.67	238,428.26	317,638.02	284,875.63	694,024.46	225,961.53	216,197.93	116,572.69
Total Revenues	9,511,558.23	9,386,197.15	9,244,982.83	9,184,001.84	9,070,396.55	8,799,996.60	8,068,529.79	8,145,012.14	7,969,744.60	7,741,859.76
EXPENDITURES:										
Instruction:										
Regular Instruction	1,943,895.93	1,850,056.80	1,831,307.79	2,232,696.46	2,131,637.49	2,135,203.38	2,196,081.35	2,194,866.06	2,096,905.95	2,003,692.30
Special Education Instruction	582,589.32	556,872.82	529,678.57	678,066.55	601,499.35	653,469.00	721,804.01	560,948.23	796,520.14	541,284.41
Other Special Instruction	57,697.64	56,758.75	55,889.25	63,336.37	53,464.74	147,763.41	117,076.39	119,587.46	56,710.77	41,610.73
Other Instruction	33,820.02	33,145.18	29,903.89	34,484.55	34,046.01	37,206.20	76,069.47	97,933.72	93,531.17	99,786.41
Support Services:										
Tuition	2,088,964.89	2,142,259.49	2,272,329.24	2,636,234.48	2,261,169.17	2,562,492.24	2,326,835.16	1,875,992.43	1,802,135.99	1,861,389.68
Student and Instruction Related Services	954,057.61	923,882.82	829,636.78	900,880.19	902,208.78	897,656.94	872,313.01	889,751.73	687,337.20	750,253.95
School Administrative Services	179,168.08	169,959.23	158,157.94	172,702.10	162,467.88	173,430.21	166,668.90	146,254.54	161,910.89	135,533.27
Other Administrative Services	369,876.30	373,402.68	335,956.70	324,721.53	323,598.23	343,138.57	383,931.53	413,385.95	461,610.71	415,827.32
Plant Operations and Maintenance	641,524.37	545,405.96	567,403.05	647,182.19	590,688.54	640,483.96	757,593.04	711,812.49	739,474.89	681,254.21
Pupil Transportation	224,239.68	193,212.82	148,887.17	291,842.96	231,581.50	206,048.28	231,813.64	169,478.71	166,125.11	201,810.92
Unallocated Benefits	1,740,478.49	1,570,178.16	1,416,679.88	541,090.14	427,896.10	363,956.25	369,968.48	364,921.58	556,507.23	509,477.64
Transfer to Charter School						3,861.00				
Debt Service:										
Principal	255,000.00	235,000.00	265,000.00	170,000.00	160,000.00	150,000.00	125,000.00	120,000.00	100,000.00	30,000.00
Interest and Other Charges	210,686.10	174,162.50	145,768.92	253,911.50	260,511.50	266,711.50	272,211.50	277,111.50	281,512.00	497,645.13
Capital Outlay	42,699.00	85,754.02	97,596.54	97,395.18	24,909.00	73,007.10	153,936.63	148,291.90	235,089.40	4,038,463.98
Total Expenditures	9,324,707.43	8,910,051.33	8,684,195.72	9,044,534.20	8,165,678.29	8,654,428.04	8,771,303.11	8,090,336.30	8,235,377.45	11,808,029.95
Excess (Deficiency) of Revenues Over (Under) Expenditures	186,850.80	476,145.82	560,787.11	139,467.64	904,718.26	145,568.56	(702,773.32)	54,675.84	(265,632.85)	(4,066,170.19)
OTHER FINANCING SOURCES (USES):										
Capital Leases (Non-budgeted)							89,236.00			
Cancellation of Special Revenue Appropriations							0.10			
Transfers In					2,772.09	49,814.38	26,428.24	49,100.16	17,852.09	49,011.28
Transfers Out			(5,563.32)		(2,772.09)	(49,814.38)	(26,428.24)	(49,100.16)	(22,852.09)	(64,011.28)
Total Other Financing Sources (Uses)	-	-	(5,563.32)	-	-	(4.29)	89,236.10	-	(5,000.00)	(15,000.00)
Net Change in Fund Balances	\$ 186,850.80	\$ 476,145.82	\$ 555,223.79	\$ 139,467.64	\$ 904,718.26	\$ 145,564.27	\$ (613,537.22)	\$ 54,675.84	\$ (270,632.85)	\$ (4,081,170.19)
Debt Service as a Percentage of Noncapital Expenditures	5.0%	4.6%	4.8%	4.7%	5.2%	4.9%	4.6%	5.0%	4.8%	6.8%

Source: Exhibit B-2

TOWNSHIP OF DELANCO SCHOOL DISTRICT
 General Fund - Other Local Revenue by Source
 Last Ten Fiscal Years (Modified Accrual Basis of Accounting)
Unaudited

	Fiscal Year Ended June 30,									
	2016	2015	2014	2013	2012	2011	2010	2009	2008	2007
Interest on Investments	\$ 6,103.77	\$ 3,409.86	\$ 3,052.57	\$ 2,700.21	\$ 1,148.28	\$ 20,674.08	\$ 32,595.04	\$ 40,576.04	\$ 61,812.63	\$ 87,949.29
Miscellaneous Facility Use	6,452.00	6,662.00	8,282.00	1,590.00	790.00	790.00	3,490.00	815.15	3,413.00	2,004.00
Rental of Library			31,540.47	7,605.00	17,706.00	10,719.95	13,105.52	19,400.00	17,000.00	17,000.00
Refund of Prior Year Expenditures	313.76	798.76			6,197.36			961.99	595.12	
E-Rate					3,506.05					
Tuition			14,142.00	33,283.59				14,064.00	7,972.60	3,532.80
JIF Safety Award	10,000.00	1,000.00	1,000.00	3,000.00						
Sale of Assets	591.65	3,020.35		3,000.00						
Donation						5,871.00				
Cancellation of Prior Year Outstanding Checks						68.67				
Ex Care Facility Use	53,000.00	53,000.00	53,000.00	50,000.00	50,000.00	42,750.00				
Ex Care Services						7,507.00				
Other	510.90	1,909.22	3,165.75		1,283.15	6,864.68	4,964.55	117.36	1,615.00	8,671.06
Total Miscellaneous Revenues	\$ 76,972.08	\$ 69,800.19	\$ 114,182.79	\$ 101,178.80	\$ 80,630.84	\$ 95,245.38	\$ 54,155.11	\$ 75,934.54	\$ 92,408.35	\$ 119,157.15

Source: District Records

Revenue Capacity Information

Revenue capacity information is intended to assist users in understanding and assessing the factors affecting the School District's ability to generate revenues. Please refer to the following exhibits for a historical view of these factors and how they relate to the School District's ability to generate revenues.

TOWNSHIP OF DELANCO SCHOOL DISTRICT
 Assessed Value and Actual Value of Taxable Property
 Last Ten Fiscal Years
Unaudited

Year Ended Dec. 31	Vacant Land	Residential	Farm	Commercial	Industrial	Apartment	Total Assessed Value	Public Utilities (2)	Net Valuation Taxable	Tax-Exempt Property	Estimated Actual (County Equalized) Value	Total Direct School Tax Rate (3)
2016	\$ 4,214,200.00	\$ 335,916,900.00	\$ 900,300.00	\$ 19,469,200.00	\$ 31,794,100.00	\$ 1,374,400.00	\$ 383,669,100.00	\$ 94.00	\$ 383,669,194.00	\$ 47,491,100.00	\$ 417,863,390.00	\$ 1.549
2015	4,381,800.00	334,027,600.00	1,047,300.00	19,578,400.00	31,231,800.00	1,374,400.00	391,641,300.00	94.00	391,641,394.00	46,778,500.00	417,839,959.00	1.527
2014 (1)	4,083,600.00	334,111,100.00	1,047,000.00	19,578,400.00	31,463,700.00	1,399,100.00	391,682,900.00	353,600.00	392,036,500.00	46,273,600.00	410,321,048.00	1.525
2013	6,858,350.00	416,473,860.00	1,022,600.00	23,627,300.00	34,768,800.00	1,365,000.00	484,115,910.00	418,616.00	484,534,526.00	57,336,700.00	419,071,204.00	1.221
2012	6,856,850.00	423,461,460.00	780,500.00	25,002,300.00	35,082,100.00	3,421,300.00	494,604,510.00	459,692.00	495,064,202.00	62,264,400.00	459,729,183.00	1.186
2011	8,499,850.00	425,961,860.00	777,000.00	26,102,300.00	33,519,300.00	2,028,100.00	496,888,410.00	462,497.00	497,350,907.00	41,456,000.00	477,139,790.00	1.186
2010	10,675,800.00	422,944,500.00	777,000.00	26,352,300.00	40,513,500.00	3,235,200.00	504,488,300.00	573,514.00	505,071,814.00	40,195,200.00	495,665,074.00	1.150
2009	12,860,300.00	411,938,800.00	782,000.00	27,602,300.00	40,513,500.00	3,235,200.00	496,932,100.00	547,114.00	497,479,214.00	39,655,200.00	497,479,214.00	1.085
2008	15,622,700.00	382,597,200.00	1,032,000.00	27,602,300.00	40,513,500.00	1,730,000.00	469,097,700.00	488,213.00	469,585,913.00	40,944,400.00	469,585,913.00	1.095
2007 (1)	15,464,700.00	373,804,400.00	1,054,200.00	42,074,500.00	27,120,000.00	1,730,000.00	461,247,800.00	451,248.00	461,699,048.00	28,309,800.00	461,699,048.00	1.046

(1) Revaluation

(2) Taxable Value of Machinery, Implements and Equipment of Telephone, Telegraph and Messenger System Companies

(3) Tax Rates are per \$100.00 of Assessed Valuation

Source: Burlington County Board of Taxation

TOWNSHIP OF DELANCO SCHOOL DISTRICT

Direct and Overlapping Property Tax Rates

Last Ten Fiscal Years

Unaudited

Year Ended <u>Dec. 31</u>	District Direct Rate (1)			Overlapping Rates (1)				Total Direct and Overlapping Tax Rate
	<u>Basic Rate</u>	General Obligation Debt <u>Service</u>	Total Direct School <u>Tax Rate</u>	Township of Delanco <u>Delanco</u>	Township of Delanco <u>Fire District</u>	Burlington <u>County</u>		
2016	\$ 1.440	\$ 0.109	\$ 1.549	\$ 1.000	\$ 0.083	\$ 0.438	\$	3.070
2015	1.429	0.098	1.527	0.961	0.083	0.448		3.019
2014 (2)	1.413	0.112	1.525	0.937	0.083	0.398		2.943
2013	1.133	0.088	1.221	0.724	0.067	0.329		2.341
2012	1.108	0.074	1.182	0.676	0.066	0.358		2.282
2011	1.107	0.079	1.186	0.648	0.064	0.365		2.263
2010	1.066	0.084	1.150	0.638	0.063	0.379		2.230
2009	1.012	0.073	1.085	0.629	0.062	0.379		2.155
2008	1.064	0.031	1.095	0.580	0.064	0.373		2.112
2007 (2)	0.974	0.072	1.046	0.549	0.065	0.375		2.035

Source: Municipal Tax Collector

(1) Rate per \$100 of Assessed Value

(2) Revaluation

TOWNSHIP OF DELANCO SCHOOL DISTRICT

Principal Property Tax Payers
Current Year and Nine Years Ago
Unaudited

	2016			2007		
	Taxable Assessed Value	Rank	% of Total District Net Assessed Value	Taxable Assessed Value (1)	Rank	% of Total District Net Assessed Value
REG Delanco 800, LLC	\$ 5,995,400.00	1	1.52%	\$ 6,100,800.00	3	1.32%
600 Creek Road LLC	5,778,700.00	2	1.47%			
REG Delanco 2700, LLC	5,451,400.00	3	1.38%	8,350,000.00	2	1.81%
John Bruce Investment Company LLC	3,684,400.00	4	0.94%	4,760,000.00	4	1.03%
Recon Investments LLC	2,747,600.00	5	0.70%			
Hovbros Coopertown Road LLC	2,721,500.00	6	0.69%	2,250,000.00	9	0.49%
FEDEX, Burke & Assoc.	2,469,500.00	7	0.63%	3,400,000.00	7	0.74%
Delanco Realty	2,140,500.00	8	0.54%	2,300,000.00	8	0.50%
Costume Gallery, Inc.	2,000,000.00	9	0.51%			
Boise Cascade Building	1,837,500.00	10	0.47%	2,100,000.00	10	0.45%
First Industrial LP				9,860,000.00	1	2.14%
SR 700 Oreek Road LLC				3,800,000.00	5	0.82%
Gres & Kaluzny Land Development LLC				3,785,900.00	6	0.82%
Total	\$ 34,826,500.00		8.85%	\$ 46,706,700.00		10.12%

(1) Revaluation

Source: Municipal Tax Assessor

TOWNSHIP OF DELANCO SCHOOL DISTRICT
Property Tax Levies and Collections
Last Ten Fiscal Years
Unaudited

<u>Fiscal Year Ended June 30,</u>	<u>School District Taxes Levied for the Fiscal Year</u>	<u>Collected within the Fiscal Year of the Levy (1)</u>		<u>Collections in Subsequent Years</u>
		<u>Amount</u>	<u>Percentage of Levy</u>	
2016	\$ 5,980,640.00	\$ 5,980,640.00	100.00%	N/A
2015	5,980,640.00	5,980,640.00	100.00%	N/A
2014	5,924,142.00	5,924,142.00	100.00%	N/A
2013	5,855,359.00	5,855,359.00	100.00%	N/A
2012	5,899,429.00	5,899,429.00	100.00%	N/A
2011	5,807,946.00	5,807,946.00	100.00%	N/A
2010	5,396,101.00	5,396,101.00	100.00%	N/A
2009	5,143,864.00	5,143,864.00	100.00%	N/A
2008	4,826,282.00	4,826,282.00	100.00%	N/A
2007	4,826,282.00	4,826,282.00	100.00%	N/A

Source: District Records

(1) School taxes are collected by the Municipal Tax Collector. Under New Jersey State Statute, a municipality is required to remit to the school district the entire property tax balance, in the amount voted upon or certified prior to the end of the school year.

Debt Capacity Information

Debt capacity information is intended to assist users in understanding and assessing the School District's debt burden and its ability to issue additional debt. Please refer to the following exhibits for a historical view of the School District's outstanding debt and its debt capacity.

TOWNSHIP OF DELANCO SCHOOL DISTRICT
 Ratios of Outstanding Debt by Type
 Last Ten Fiscal Years
Unaudited

Fiscal Year Ended <u>June 30,</u>	Governmental Activities		Business-Type Activities		Percentage of Personal Income (2)	Per Capita (3)
	General Obligation Bonds (1)	Capital Leases	Capital Leases	Total District		
2016	\$ 5,455,000.00	\$ -	\$ -	\$ 5,455,000.00	Unavailable	Unavailable
2015	5,710,000.00			5,710,000.00	Unavailable	\$ 1,257.43
2014	5,945,000.00			5,945,000.00	2.43%	1,304.59
2013	6,210,000.00			6,210,000.00	2.63%	1,362.74
2012	6,076,000.00			6,076,000.00	2.61%	1,342.17
2011	6,236,000.00	29,855.20		6,265,855.20	2.77%	1,382.58
2010	6,386,000.00	58,196.52		6,444,196.52	3.12%	1,499.70
2009	6,511,000.00			6,511,000.00	2.86%	1,362.99
2008	6,631,000.00			6,631,000.00	2.99%	1,430.64
2007	6,731,000.00	7,282.06		6,738,282.06	3.35%	1,545.48

Sources:

- (1) District Records
- (2) Personal income has been estimated based upon Burlington County population and per capita
- (3) Per Capita personal income of Burlington County-estimated based upon the 2000 Census published

TOWNSHIP OF DELANCO SCHOOL DISTRICT
 Ratios of Net General Bonded Debt Outstanding
 Last Ten Fiscal Years
Unaudited

Fiscal Year Ended June 30,	General Bonded Debt Outstanding		Net General Bonded Debt Outstanding (1)	Percentage of Net Assessed Valuation Taxable (2)	Per Capita (3)
	General Obligation Bonds	Deductions			
2016	\$ 5,455,000.00	\$ -	\$ 5,455,000.00	1.39%	Unavailable
2015	5,710,000.00		5,710,000.00	1.46%	\$ 1,257.43
2014	5,945,000.00		5,945,000.00	1.52%	1,304.59
2013	6,210,000.00		6,210,000.00	1.28%	1,362.74
2012	6,076,000.00		6,076,000.00	1.23%	1,342.17
2011	6,236,000.00		6,236,000.00	1.25%	1,375.99
2010	6,386,000.00		6,386,000.00	1.26%	1,486.15
2009	6,511,000.00		6,511,000.00	1.31%	1,362.99
2008	6,631,000.00		6,631,000.00	1.41%	1,430.64
2007	6,731,000.00		6,731,000.00	1.46%	1,543.81

Sources:

- (1) District Records
- (2) Net Assessed Valuation provided by Abstract of Ratables, County Board of Taxation.
- (3) Per Capita calculation based upon population information provided by the NJ Dept of Labor and Workforce Development.

TOWNSHIP OF DELANCO SCHOOL DISTRICT
 Direct and Overlapping Governmental Activities Debt
 As of December 31, 2015
Unaudited

	<u>Gross Debt</u>	<u>Deductions</u>	<u>Statutory Net Debt Outstanding</u>	<u>Net Debt Outstanding Allocated to Delanco Township</u>
Municipal Debt: (1)				
Local School District	\$ 5,455,000.00	\$ 5,455,000.00	\$ -	\$ -
Delanco Township	<u>2,760,491.88</u>	<u>-</u>	<u>2,760,491.88</u>	<u>2,760,491.88</u>
	<u>8,215,491.88</u>	<u>5,455,000.00</u>	<u>2,760,491.88</u>	<u>2,760,491.88</u>
Overlapping Debt Apportioned to the Municipality:				
County of Burlington: (2)				
General:				
Bonds	246,889,847.00		217,095,200.00	1,991,048.68 (5)
Bonds Issued by Other Public Bodies		29,794,647.00 (3)		
Guaranteed by the County	342,954,000.00	342,954,000.00 (4)		
Solid Waste Utility	<u>68,999,492.00</u>	<u>68,999,492.00</u>		
	<u>658,843,339.00</u>	<u>441,748,139.00</u>	<u>217,095,200.00</u>	<u>1,991,048.68</u>
	<u>\$ 667,058,830.88</u>	<u>\$ 447,203,139.00</u>	<u>\$ 219,855,691.88</u>	<u>\$ 4,751,540.56</u>

Sources:

- (1) 2015 Report of Audit
- (2) County's 2015 Audit Report
- (3) Includes cash on hand, accounts receivable and County College Bonds paid with State Aid.
- (4) Deductible in accordance with N.J.S. 40:37A-80.
- (5) Such debt is allocated as a proportion of the Township's share of the total 2015 Equalized Value, which is 0.92%.
 The source for this computation was the 2015 Table of Equalized Valuations, which is supplied by the New Jersey Division of Taxation.

TOWNSHIP OF DELANCO SCHOOL DISTRICT
 Legal Debt Margin Information
 Last Ten Fiscal Years
Unaudited

Legal Debt Margin Calculation for Fiscal Year 2016

Equalized Valuation Basis (1):	
2015	\$ 415,710,965.00
2014	417,884,242.00
2013	414,852,197.00
[A]	\$ 1,248,447,404.00
[A/3]	\$ 416,149,134.67
[B]	\$ 12,484,474.04
[C]	5,455,000.00
[B-C]	\$ 7,029,474.04

Average Equalized Valuation of Taxable Property

Debt Limit (3% of Average Equalization Value) (2)
 Total Net Debt Applicable to Limit (3)

Legal Debt Margin

	Fiscal Year Ended June 30,									
	2016	2015	2014	2013	2012	2011	2010	2009	2008	2007
Debt Limit	\$ 12,484,474.04	\$ 12,601,882.67	\$ 13,035,389.73	\$ 13,726,644.24	\$ 14,328,790.34	\$ 14,330,819.18	\$ 13,849,838.77	\$ 12,775,644.23	\$ 11,311,955.57	\$ 9,452,633.97
Total Net Debt Applicable to Limit (3)	5,455,000.00	5,455,000.00	5,945,000.00	6,210,000.00	6,076,000.00	6,236,000.00	6,386,000.00	6,511,000.00	6,631,000.00	6,731,000.00
Legal Debt Margin	\$ 7,029,474.04	\$ 7,146,882.67	\$ 7,090,389.73	\$ 7,516,644.24	\$ 8,252,790.34	\$ 8,094,819.18	\$ 7,463,838.77	\$ 6,264,644.23	\$ 4,680,955.57	\$ 2,721,633.97
Total net debt applicable to the limit as a percentage of debt limit	43.69%	43.29%	45.61%	45.24%	42.40%	43.51%	46.11%	50.96%	58.62%	71.21%

Sources:

- (1) Equalized valuation bases were provided by the Annual Report of the State of New Jersey, Department of Treasury, Division of Taxation.
- (2) Limit set by NJSA 18A:24-19 for a K through 8 district.
- (3) District Records

Demographic and Economic Information

Demographic and economic information is intended (1) to assist users in understanding the socioeconomic environment within which the School District operates and (2) to provide information that facilitates comparisons of financial statement information over time and among school districts. Please refer to the following exhibits for a historical view of the demographic and economic statistics and factors prevalent in the location in which the School District operates.

TOWNSHIP OF DELANCO SCHOOL DISTRICT
 Demographic and Economic Statistics
 Last Ten Fiscal Years
Unaudited

<u>Year</u>	<u>Population (1)</u>	<u>Personal Income (2)</u>	<u>Per Capita Personal Income (3)</u>	<u>Unemployment Rate (4)</u>
2015	4,541	\$ 244,065,127.00	\$ 53,747.00 (5)	6.5%
2014	4,557	244,925,079.00	53,747.00	8.0%
2013	4,557	235,984,245.00	51,785.00	7.5%
2012	4,527	232,642,530.00	51,390.00	14.0%
2011	4,532	226,396,060.00	49,955.00	13.5%
2010	4,297	206,457,959.00	48,047.00	13.9%
2009	4,777	227,619,273.00	47,649.00	13.1%
2008	4,635	221,627,160.00	47,816.00	7.7%
2007	4,360	201,379,680.00	46,188.00	5.7%
2006	4,184	186,531,088.00	44,582.00	6.3%

Sources:

- (1) Population information provided by the NJ Dept. of Labor and Workforce Development.
- (2) Personal income has been estimated based upon the municipal population and per capita income.
- (3) Per Capita personal income by municipality-estimated based upon mid-year population estimates on a county basis.
- (4) Unemployment data provided by the NJ Dept. of Labor and Workforce Development.
- (5) Estimated

Operating Information

Operating information is intended to provide contextual information about the School District's operations and resources to assist readers in using financial statement information to understand and assess the School District's economic condition. Please refer to the following exhibits for a historical view of the factors and statistics pertinent to the School District's operations.

TOWNSHIP OF DELANCO SCHOOL DISTRICT
 Full-time Equivalent District Employees by Function/Program
 Last Ten Fiscal Years
Unaudited

Function/Program:	Fiscal Year Ended June 30,									
	2016	2015	2014	2013	2012	2011	2010	2009	2008	2007
Instruction:										
Regular	28	27	26	26	23	24	38	34	34	34
Special education	14	12	13	19	12	10	1	-	-	-
Other special education	-	-	-	-	-	-	-	-	-	-
Vocational	-	-	-	-	-	-	-	-	-	-
Other instruction	-	-	-	-	-	-	-	-	-	-
Nonpublic school programs	-	-	-	-	-	-	-	-	-	-
Adult/continuing education programs	-	-	-	-	-	-	-	-	-	-
Support Services:										
Tuition	-	-	-	-	-	-	-	-	-	-
Student & instruction related services	8	7	7	3	7	5	8	11	11	6
General administrative services	1	1	2	2	1	2	1	3	3	3
School administrative services	2	2	2	-	2	2	2	2	2	1
Business administrative services	1	1	1	1	2	2	2	2	1	1
Plant operations and maintenance	6	6	6	9	5	5	7	6	6	6
Pupil transportation	1	1	1	2	1	2	1	1	1	2
Other Support Services	-	-	-	-	-	-	-	-	-	-
Food Service	-	-	-	-	-	-	-	-	-	-
Total	60	56	58	62	53	52	61	59	59	53

Source: District Records

TOWNSHIP OF DELANCO SCHOOL DISTRICT
 Operating Statistics
 Last Ten Fiscal Years
Unaudited

Fiscal Year Ended June 30,	Enrollment	Operating Expenditures	Cost Per Pupil	Percentage Change	Teaching Staff	Pupil/Teacher Ratio		Average Daily Enrollment (ADE)	Average Daily Attendance (ADA)	% Change in Average Daily Enrollment	Student Attendance Percentage
						Elementary	Middle School				
2016	392	\$ 8,816,322.33	\$ 22,502.10	2.44%	34	11.7	11.2	392	374	1.24%	95.46%
2015	387	8,500,888.83	21,966.12	3.81%	36	10.6	11.1	387	368	-0.73%	95.09%
2014	391	8,273,426.80	21,159.66	-3.92%	34	11.9	9.9	390	374	1.00%	96.02%
2013	387	8,523,227.52	22,023.84	10.69%	37	16.0	7.0	386	369	-1.78%	95.60%
2012	388	7,720,257.79	19,897.57	-3.25%	36	12.0	8.8	393	377	1.94%	95.93%
2011	397	8,164,709.44	20,566.02	-1.68%	32	11.1	8.7	386	368	-2.89%	95.37%
2010	393	8,220,154.98	20,916.42	7.56%	40	9.8	9.8	397	379	1.79%	95.47%
2009	388	7,544,932.90	19,445.70	-0.71%	38	10.2	10.2	390	371	-0.36%	95.13%
2008	389	7,618,776.05	19,585.54	0.48%	37	11.8	11.8	391	371	6.07%	94.76%
2007	376	7,328,920.84	19,491.81	10.37%	35	10.5	10.5	369	353	2.79%	95.61%

Sources: District Records

TOWNSHIP OF DELANCO SCHOOL DISTRICT
 School Building Information
 Last Ten Fiscal Years
Unaudited

	Fiscal Year Ended June 30,									
	2016	2015	2014	2013	2012	2011	2010	2009	2008	2007
<u>District Building</u>										
<u>Elementary</u>										
Pearson Elementary (1961)	54,212	54,212	54,212	54,212	54,212	54,212	54,212	54,212	54,212	54,212
Square Feet	432	432	432	432	432	432	432	432	432	432
Capacity (students)	262	266	275	285	265	266	257	257	258	250
Enrollment										
<u>Middle School</u>										
Walnut Street Middle School (1925)	29,475	29,475	29,475	29,475	29,475	29,475	29,475	29,475	29,475	29,475
Square Feet	207	207	207	207	207	207	207	207	207	207
Capacity (students)	130	121	116	102	123	131	136	131	131	126
Enrollment										
<u>Other</u>										
Maintenance Building (1997)	907	907	907	907	907	907	907	907	907	907
Square Feet										

Number of Schools at June 30, 2016
 Elementary = 1
 Middle School = 1

Source: District Records

TOWNSHIP OF DELANCO SCHOOL DISTRICT
 Schedule of Required Maintenance
 Last Ten Fiscal Years
Unaudited

UNDISTRIBUTED EXPENDITURES - REQUIRED MAINTENANCE FOR SCHOOL FACILITIES (11-000-261-XXX)

School Facilities*	Project # (s)	Fiscal Year Ended June 30,									
		2016	2015	2014	2013	2012	2011	2010	2009	2008	2007
Pearson Elementary School	30	\$ 85,104.26	\$ 23,323.57	\$ 31,958.91	\$ 17,603.42	\$ 24,180.32	\$ 14,822.33	\$ 38,323.01	\$ 27,393.36	\$ 26,426.77	\$ 34,227.93
Walnut Street Middle School	60	30,304.00	8,945.84	16,143.90	14,285.02	10,685.25	9,214.56	22,723.37	12,096.32	13,599.45	6,715.12
Total School Facilities		115,408.26	32,269.41	48,102.81	31,888.44	34,865.57	24,036.89	61,046.38	39,489.68	40,026.22	40,943.05
Grand Total		<u>\$ 115,408.26</u>	<u>\$ 32,269.41</u>	<u>\$ 48,102.81</u>	<u>\$ 31,888.44</u>	<u>\$ 34,865.57</u>	<u>\$ 24,036.89</u>	<u>\$ 61,046.38</u>	<u>\$ 39,489.68</u>	<u>\$ 40,026.22</u>	<u>\$ 40,943.05</u>

Source: District Records

* School Facilities as defined under EFCFA. (N.J.A.C. 6A:26-1.2 and N.J.A.C. 6A:26A-1.3)

TOWNSHIP OF DELANCO SCHOOL DISTRICT

Insurance Schedule

June 30, 2016

Unaudited

	<u>Coverage</u>	<u>Deductible</u>
Burlington County Insurance Pool Joint Insurance Fund:		
Property, Inland Marine and Auto Physical Damage	\$ 150,000,000.00	\$ 500.00
Boiler and Machinery	125,000,000.00	1,000.00
General and Auto Liability	20,000,000.00	
Comprehensive Crime	500,000.00	500.00
Educator's Legal Liability	20,000,000.00	
Pollution Legal Liability	3,000,000.00	25,000.00
Cyber Liability	1,000,000.00	25,000.00
Violent Malicious Acts	1,000,000.00	15,000.00
Workers Compensation	Statutory	
National Union Fire Insurance Company:		
Student Accident Liability	1,000,000.00	
Travelers Casualty and Surety Company of America:		
Public Official Bond - School Business Administrator/Board Secretary	190,000.00	

Source: District Records

SINGLE AUDIT SECTION

**REPORT ON COMPLIANCE FOR EACH MAJOR PROGRAM AND REPORT ON INTERNAL CONTROL
OVER COMPLIANCE REQUIRED BY STATE OF NEW JERSEY CIRCULAR 15-08-OMB**

INDEPENDENT AUDITOR'S REPORT

The Honorable President and
Members of the Board of Education
Township of Delanco School District
Delanco, New Jersey 08075

Report on Compliance for Each Major State Program

We have audited the Township of Delanco School District's, in the County of Burlington, State of New Jersey, compliance with the types of compliance requirements described in the *New Jersey State Grant Compliance Supplement* that could have a direct and material effect on the School District's major state program for the fiscal year ended June 30, 2016. The School District's major state program is identified in the *Summary of Auditor's Results* section of the accompanying *Schedule of Findings and Questioned Costs*.

Management's Responsibility

Management is responsible for compliance with state statutes, regulations, and the terms and conditions of its state awards applicable to its state programs.

Auditor's Responsibility

Our responsibility is to express an opinion on compliance for the School District's major state program based on our audit of the types of compliance requirements referred to above. We conducted our audit of compliance in accordance with auditing standards generally accepted in the United States of America; the standards applicable to financial audits contained in *Government Auditing Standards*, issued by the Comptroller General of the United States; audit requirements as prescribed by the Division of Administration and Finance, Department of Education, State of New Jersey; and State of New Jersey Circular 15-08-OMB, *Single Audit Policy for Recipients of Federal Grants, State Grants and State Aid*. Those standards and State of New Jersey Circular 15-08-OMB require that we plan and perform the audit to obtain reasonable assurance about whether noncompliance with the types of compliance requirements referred to above that could have a direct and material effect on a major state program occurred. An audit includes examining, on a test basis, evidence about the Township of Delanco School District's, in the County of Burlington, State of New Jersey, compliance with those requirements and performing such other procedures as we considered necessary in the circumstances.

We believe that our audit provides a reasonable basis for our opinion on compliance for the major state program. However, our audit does not provide a legal determination of the School District's compliance.

Opinion on Each Major State Program

In our opinion, the Township of Delanco School District, in the County of Burlington, State of New Jersey, complied, in all material respects, with the types of compliance requirements referred to above that could have a direct and material effect on each of its major state program for the fiscal year ended June 30, 2016.

Report on Internal Control Over Compliance

Management of the Township of Delanco School District, in the County of Burlington, State of New Jersey, is responsible for establishing and maintaining effective internal control over compliance with the types of compliance requirements referred to above. In planning and performing our audit of compliance, we considered the School District's internal control over compliance with the types of requirements that could have a direct and material effect on the major state program to determine the auditing procedures that are appropriate in the circumstances for the purpose of expressing an opinion on compliance for the major state program and to test and report on internal control over compliance in accordance with State of New Jersey Circular 15-08-OMB, but not for the purpose of expressing an opinion on the effectiveness of internal control over compliance. Accordingly, we do not express an opinion on the effectiveness of the School District's internal control over compliance.

A deficiency in internal control over compliance exists when the design or operation of a control over compliance does not allow management or employees, in the normal course of performing their assigned functions, to prevent, or detect and correct, noncompliance with a type of compliance requirement of a state program on a timely basis. *A material weakness in internal control over compliance* is a deficiency, or combination of deficiencies, in internal control over compliance, such that there is a reasonable possibility that material noncompliance with a type of compliance requirement of a state program will not be prevented, or detected and corrected, on a timely basis. *A significant deficiency in internal control over compliance* is a deficiency, or a combination of deficiencies, in internal control over compliance with a type of compliance requirement of a state program that is less severe than a material weakness in internal control over compliance, yet important enough to merit attention by those charged with governance.

Our consideration of internal control over compliance was for the limited purpose described in the first paragraph of this section and was not designed to identify all deficiencies in internal control over compliance that might be material weaknesses or significant deficiencies. We did not identify any deficiencies in internal control over compliance that we consider to be material weaknesses. However, material weaknesses may exist that have not been identified.

The purpose of this report on internal control over compliance is solely to describe the scope of our testing of internal control over compliance and the results of that testing based on the requirements of State of New Jersey Circular 15-08-OMB. Accordingly, this report is not suitable for any other purpose.

Respectfully submitted,

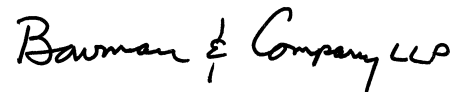

BOWMAN & COMPANY LLP
Certified Public Accountants
& Consultants



Robert P. Nehila Jr.
Certified Public Accountant
Public School Accountant No. CS 002065

Voorhees, New Jersey
November 30, 2016

TOWNSHIP OF DELANCO SCHOOL DISTRICT
 Schedule of Expenditures of Federal Awards, Schedule A
 For the Fiscal Year Ended June 30, 2016

<u>Pass-through</u> Grantor / Program Title	Federal CFDA Number	Federal FAIN Number	Pass Through Entity Identifying Number	Program or Award Amount	Grant Period		Balance June 30, 2015	Carryover / (Walkover) Amount
					From	To		
Special Revenue Fund:								
U.S. Department of Education Passed-through								
State Department of Education:								
N.C.L.B.:								
Title I, Part A	84.010A	S010A150030	NCLB-1030-16	\$ 94,408.00	7-1-15	6-30-16	\$ -	\$ -
Title I, Part A	84.010A	S010A150030	NCLB-1030-15	91,547.00	7-1-14	6-30-15	(16,066.00)	
Total Title I, Part A							(16,066.00)	-
Title II, Part A	84.367A	S367A150029	NCLB-1030-16	16,759.00	7-1-15	6-30-16		
Title II, Part A	84.367A	S367A150029	NCLB-1030-15	16,952.00	7-1-14	6-30-15	(3,781.00)	
Total Title II Part A							(3,781.00)	-
I.D.E.A. Part B:								
Special Education Cluster:								
Basic and Capacity	84.027	H027A150100	IDEA-1030-16	129,479.00	7-1-15	6-30-16		
Basic and Capacity	84.027	H027A150100	IDEA-1030-15	126,230.00	7-1-14	6-30-15	(126,230.00)	
Preschool	84.173	H173A150114	IDEA-1030-16	3,263.00	7-1-15	6-30-16		
Preschool	84.173	H173A150114	IDEA-1030-15	3,161.00	7-1-14	6-30-15		
Total I.D.E.A. Part B, Special Education Cluster							(126,230.00)	-
Total Special Revenue Fund							(146,077.00)	-
Enterprise Fund:								
U.S. Department of Agriculture:								
Passed-through State Department of Education:								
Child Nutrition Cluster:								
Non-Cash Assistance (Food Distribution Program):								
Food Distribution Program	10.555	16161NJ304N1099	Unavailable	13,924.26	7-1-15	6-30-16		
Food Distribution Program	10.555	16161NJ304N1099	Unavailable	12,882.38	7-1-14	6-30-15	642.18	
Cash Assistance:								
National School Lunch Program	10.555	16161NJ304N1099	Unavailable	67,709.55	7-1-15	6-30-16		
National School Lunch Program	10.555	16161NJ304N1099	Unavailable	63,893.96	7-1-14	6-30-15	(3,792.18)	
School Breakfast Program	10.553	16161NJ304N1099	Unavailable	11,151.64	7-1-15	6-30-16		
School Breakfast Program	10.553	16161NJ304N1099	Unavailable	11,669.54	7-1-14	6-30-15	(868.79)	
Total Child Nutrition Cluster							(4,018.79)	-
Total Federal Financial Assistance							\$ (150,095.79)	\$ -

The accompanying Notes to Financial Statements and Notes to the Schedules of Expenditures of Federal Awards and State Financial Assistance are an integral part of this schedule.

These funds were not audited in accordance with the Uniform Guidance since the total of all grant expenditures did not exceed \$750,000.

Cash Received	Budgetary Expenditures			Passed - Through to Subrecipients	Adjustments	Repayment of Prior Years' Balances	Balance June 30, 2016		
	Pass-Through Funds	Direct Funds	Total Budgetary Expenditures				(Accounts Receivable)	Unearned Revenue	Due to Grantor
\$ 56,071.00 16,066.00	\$ 94,408.00	\$ -	\$ 94,408.00	\$ -	\$ -	\$ -	\$ (38,337.00)	\$ -	\$ -
72,137.00	94,408.00	-	94,408.00	-	-	-	(38,337.00)	-	-
11,376.00 3,781.00	16,759.00		16,759.00				(5,383.00)		
15,157.00	16,759.00	-	16,759.00	-	-	-	(5,383.00)	-	-
126,230.00 3,263.00	129,479.00 3,263.00		129,479.00 3,263.00				(129,479.00)		
129,493.00	132,742.00	-	132,742.00	-	-	-	(129,479.00)	-	-
216,787.00	243,909.00	-	243,909.00	-	-	-	(173,199.00)	-	-
13,924.26	12,559.36 642.18		12,559.36 642.18					1,364.90	
64,628.14 3,792.18	67,709.55		67,709.55				(3,081.41)		
10,387.07 868.79	11,151.64		11,151.64				(764.57)		
93,600.44	92,062.73	-	92,062.73	-	-	-	(3,845.98)	1,364.90	
\$ 310,387.44	\$ 335,971.73	\$ -	\$ 335,971.73	\$ -	\$ -	\$ -	\$ (177,044.98)	\$ 1,364.90	\$ -

TOWNSHIP OF DELANCO SCHOOL DISTRICT
 Schedule of Expenditures of State Financial Assistance, Schedule B
 For the Fiscal Year Ended June 30, 2016

State Grantor/ Program Title	Grant or State Project Number	Program or Award Amount	Grant Period		Balance at June 30, 2015		Carryover / Walkover Amount
			From	To	Unearned Revenue/ Accounts Receivable	Due to Grantor	
General Fund:							
New Jersey Department of Education							
Current Expense:							
State Aid - Public Cluster:							
Equalization Aid	16-495-034-5120-078	\$ 2,114,805.00	7-1-15	6-30-16	\$ -	\$ -	\$ -
Equalization Aid	15-495-034-5120-078	2,114,805.00	7-1-14	6-30-15	(180,175.59)		
Special Education Categorical Aid	16-495-034-5120-089	313,392.00	7-1-15	6-30-16			
Special Education Categorical Aid	15-495-034-5120-089	313,392.00	7-1-14	6-30-15	(26,700.14)		
Security Aid	16-495-034-5120-084	22,608.00	7-1-15	6-30-16			
Security Aid	15-495-034-5120-084	22,608.00	7-1-14	6-30-15	(1,926.14)		
Per Pupil Growth Aid	16-495-034-5120-097	5,300.00	7-1-15	6-30-16			
Per Pupil Growth Aid	15-495-034-5120-097	5,300.00	7-1-14	6-30-15	(451.55)		
PARCC Readiness Aid	16-495-034-5120-098	5,300.00	7-1-15	6-30-16			
PARCC Readiness Aid	15-495-034-5120-098	5,300.00	7-1-14	6-30-15	(451.55)		
Total State Aid - Public Cluster					(209,704.97)	-	-
Transportation Aid:							
Transportation Aid	16-495-034-5120-014	24,250.00	7-1-15	6-30-16			
Transportation Aid	15-495-034-5120-014	24,250.00	7-1-14	6-30-15	(2,066.03)		
Nonpublic School Transportation Aid	16-495-034-5120-015	4,002.00	7-1-15	6-30-16			
Nonpublic School Transportation Aid	15-495-034-5120-015	3,480.00	7-1-14	6-30-15	(3,480.00)		
Total Transportation Aid					(5,546.03)	-	-
Extraordinary Aid							
Extraordinary Aid	16-100-034-5120-473	65,798.00	7-1-15	6-30-16			
Extraordinary Aid	15-100-034-5120-473	34,142.00	7-1-14	6-30-15	(34,142.00)		
Total Extraordinary Aid					(34,142.00)	-	-
Reimbursed TPAF Social Security Contributions	16-495-034-5095-003	182,215.44	7-1-15	6-30-16			
Total General Fund					(249,393.00)	-	-
Enterprise Fund:							
State School Lunch Aid	16-100-010-3350-023	1,730.25	7-1-15	6-30-16			
State School Lunch Aid	15-100-010-3350-023	1,658.98	7-1-14	6-30-15	(97.20)		
Total Enterprise Fund					(97.20)	-	-
Total State Financial Assistance Subject to Major Program Determination for State Single Audit					(249,490.20)	-	-
State Financial Assistance not Subject to Calculation for Major Program Determination for State Single Audit:							
General Fund (Non-Cash Assistance):							
New Jersey Department of the Treasury:							
On-behalf T.P.A.F. Pension Contributions - Normal Cost	495-034-5094-002	176,281.00	7-1-15	6-30-16			
On-behalf T.P.A.F. Pension Contributions - Insurance	495-034-5094-004	8,781.00	7-1-15	6-30-16			
On-behalf T.P.A.F. Pension Contributions - Post-Retirement Medical	495-034-5094-001	220,359.00	7-1-15	6-30-16			
Total General Fund (Non-Cash Assistance)					-	-	-
Total State Financial Assistance					\$ (249,490.20)	\$ -	\$ -

The accompanying Notes to Financial Statements and Notes to the Schedules of Expenditures of Federal Awards and State Financial Assistance are an integral part of this schedule.

Cash Received	Total Budgetary Expenditures	Passed-Through to Subrecipients	Adjustments	Repayment of Prior Years' Balances	Balance June 30, 2016			Memo	
					(Accounts Receivable)	Unearned Revenue	Due to Grantor	Budgetary Receivable June 30, 2016	Cumulative Total Expenditures
\$ 1,936,975.91	\$ 2,114,805.00	\$ -	\$ -	\$ -	\$ (177,829.09)	\$ -	\$ -	\$ (177,829.09)	\$ 2,114,805.00
180,175.59									
287,039.59	313,392.00				(26,352.41)			(26,352.41)	313,392.00
26,700.14									
20,706.95	22,608.00				(1,901.05)			(1,901.05)	22,608.00
1,926.14									
4,854.34	5,300.00				(445.66)			(445.66)	5,300.00
451.55									
4,854.34	5,300.00				(445.66)			(445.66)	5,300.00
451.55									
<u>2,464,136.10</u>	<u>2,461,405.00</u>	<u>-</u>	<u>-</u>	<u>-</u>	<u>(206,973.87)</u>	<u>-</u>	<u>-</u>	<u>(206,973.87)</u>	<u>2,461,405.00</u>
22,210.87	24,250.00				(2,039.13)			(2,039.13)	24,250.00
2,066.03									
	4,002.00				(4,002.00)				4,002.00
<u>3,480.00</u>									
<u>27,756.90</u>	<u>28,252.00</u>	<u>-</u>	<u>-</u>	<u>-</u>	<u>(6,041.13)</u>	<u>-</u>	<u>-</u>	<u>(2,039.13)</u>	<u>28,252.00</u>
34,142.00	65,798.00				(65,798.00)				65,798.00
<u>34,142.00</u>	<u>65,798.00</u>	<u>-</u>	<u>-</u>	<u>-</u>	<u>(65,798.00)</u>	<u>-</u>	<u>-</u>	<u>-</u>	<u>65,798.00</u>
173,171.16	182,215.44				(9,044.28)				182,215.44
<u>2,699,206.16</u>	<u>2,737,670.44</u>	<u>-</u>	<u>-</u>	<u>-</u>	<u>(287,857.28)</u>	<u>-</u>	<u>-</u>	<u>(209,013.00)</u>	<u>2,737,670.44</u>
1,652.31	1,730.25				(77.94)				1,730.25
97.20									
<u>1,749.51</u>	<u>1,730.25</u>	<u>-</u>	<u>-</u>	<u>-</u>	<u>(77.94)</u>	<u>-</u>	<u>-</u>	<u>-</u>	<u>1,730.25</u>
<u>2,700,955.67</u>	<u>2,739,400.69</u>	<u>-</u>	<u>-</u>	<u>-</u>	<u>(287,935.22)</u>	<u>-</u>	<u>-</u>	<u>(209,013.00)</u>	<u>2,739,400.69</u>
176,281.00	176,281.00								176,281.00
8,781.00	8,781.00								8,781.00
220,359.00	220,359.00								220,359.00
<u>405,421.00</u>	<u>405,421.00</u>	<u>-</u>	<u>-</u>	<u>-</u>	<u>-</u>	<u>-</u>	<u>-</u>	<u>-</u>	<u>405,421.00</u>
<u>\$ 3,106,376.67</u>	<u>\$ 3,144,821.69</u>	<u>\$ -</u>	<u>\$ -</u>	<u>\$ -</u>	<u>\$ (287,935.22)</u>	<u>\$ -</u>	<u>\$ -</u>	<u>\$ (209,013.00)</u>	<u>\$ 3,144,821.69</u>

TOWNSHIP OF DELANCO SCHOOL DISTRICT
Notes to Schedules of Expenditures of Federal Awards and State Financial Assistance
For the Fiscal Year Ended June 30, 2016

Note 1: BASIS OF PRESENTATION

The accompanying schedules of expenditures of federal awards and state financial assistance include federal and state award activity of the Township of Delanco School District (hereafter referred to as the "School District"). The School District is defined in note 1 to the School District's basic financial statements. The information in these schedules is presented in accordance with the requirements of Title 2 U.S. Code of Federal Regulations (CFR) Part 200, *Uniform Administrative Requirements, Cost Principles, and Audit Requirements for Federal Awards* (Uniform Guidance) and State of New Jersey Circular 15-08-OMB, *Single Audit Policy for Recipients of Federal Grants, State Grants and State Aid*. All federal and state awards received directly from federal and state agencies, as well as federal awards and state financial assistance passed through other government agencies, are included on the schedules of expenditures of federal awards and state financial assistance. Because these schedules present only a selected portion of the operations of the School District, it is not intended to and does not present the financial position and changes in operations of the School District.

Note 2: SUMMARY OF SIGNIFICANT ACCOUNTING POLICIES

The accompanying schedules of expenditures of federal awards and state financial assistance are presented using the budgetary basis of accounting, with the following exceptions: programs recorded in the enterprise fund are presented using the accrual basis of accounting. These bases of accounting are described in note 1 to the School District's basic financial statements. Such expenditures are recognized following the cost principles contained in Title 2 U.S. Code of Federal Regulations (CFR) Part 200, *Uniform Administrative Requirements, Cost Principles, and Audit Requirements for Federal Awards*, and State of New Jersey Circular 15-08-OMB, *Single Audit Policy for Recipients of Federal Grants, State Grants and State Aid*, wherein certain types of expenditures are not allowed or are limited as to reimbursement. The School District has elected not to use the 10-percent de minimis indirect cost rate allowed under Uniform Guidance.

Note 3: RELATIONSHIP TO BASIC FINANCIAL STATEMENTS

The basic financial statements present the general fund and special revenue fund on a GAAP basis. Budgetary comparison statements or schedules (RSI) are presented for the general fund and special revenue fund to demonstrate finance-related legal compliance in which certain revenue is permitted by law or grant agreement to be recognized in the audit year, whereas for GAAP reporting, revenue is not recognized until the subsequent year or when expenditures have been made.

The general fund is presented in the accompanying schedules on the modified accrual basis with the exception of the revenue recognition of the one or more deferred June state aid payments in the current budget year, which is mandated pursuant to N.J.S.A. 18A:22-44.2. For GAAP purposes, payments are not recognized until the subsequent budget year due to the State deferral and recording of the one or more June state aid payments in the subsequent year. The special revenue fund is presented in the accompanying schedules on the budgetary basis which recognizes encumbrances as expenditures and also recognizes the related revenues, whereas the GAAP basis does not. The special revenue fund also recognizes the one or more June state aid payments in the current budget year, consistent with N.J.S.A. 18A:22-44.2.

Note 3: RELATIONSHIP TO BASIC FINANCIAL STATEMENTS (CONT'D)

There is no adjustment to reconcile expenditures from the budgetary basis to the GAAP basis for the general fund or the special revenue fund. See exhibit C-3, notes to required supplementary information, for a reconciliation of the budgetary basis to the modified accrual basis of accounting for the general and special revenue funds.

Awards and financial assistance expenditures reported in the School District's basic financial statements on a GAAP basis are presented as follows:

<u>Fund</u>	<u>Federal</u>	<u>State</u>	<u>Total</u>
General	\$ -	\$ 2,737,730.44	\$ 2,737,730.44
Special Revenue	243,909.00		243,909.00
Food Service	92,062.73	1,730.25	93,792.98
	<u> </u>	<u> </u>	<u> </u>
Total Awards and Financial Assistance	<u>\$ 335,971.73</u>	<u>\$ 2,739,460.69</u>	<u>\$ 3,075,432.42</u>

Note 4: RELATIONSHIP TO FEDERAL AND STATE FINANCIAL REPORTS

Amounts reported in the accompanying schedules agree with the amounts reported in the related federal and state financial reports.

Note 5: REIMBURSED AND ON-BEHALF PAYMENTS

During the fiscal year ended June 30, 2016, the School District was the recipient of federal and state assistance that represented either a reimbursement to the School District or payments made on-behalf of the School District. Revenues and expenditures reported under the federal food distribution program represent the current year value received and the current year distribution, respectively, of American-grown United States Department of Agriculture foods utilized in the School District's food service program. TPAF Social Security Contributions represents the amount reimbursed by the State for the employer's share of social security contributions for TPAF members for the fiscal year. Lastly, the School District has recognized as revenues and expenditures on-behalf payments made by the State for normal costs, non-contributory insurance, and post-retirement medical costs related to TPAF members.

Note 6: MAJOR PROGRAMS

Major programs are identified in the *Summary of Auditor's Results* section of the *Schedule of Findings and Questioned Costs*.

TOWNSHIP OF DELANCO SCHOOL DISTRICT
Schedule of Findings and Questioned Costs
For the Fiscal Year Ended June 30, 2016

Section 1- Summary of Auditor's Results

Financial Statements

Type of auditor's report issued Unmodified
Internal control over financial reporting:
Material weakness(es) identified? yes no
Significant deficiency(ies) identified? yes none reported
Noncompliance material to financial statements noted? yes no

Federal Awards

THIS SECTION IS NOT APPLICABLE

Internal control over major programs:
Material weakness(es) identified? yes no
Significant deficiency(ies) identified? yes none reported
Type of auditor's report issued on compliance for major programs _____
Any audit findings disclosed that are required to be reported in accordance with Section 516 of Title 2 U.S. Code of Federal Regulations Part 200, *Uniform Administrative Requirements, Cost Principles, and Audit Requirements for Federal Awards* (Uniform Guidance)? yes no

Identification of major programs:

<u>CFDA Number(s)</u>	<u>FAIN Number(s)</u>	<u>Name of Federal Program or Cluster</u>
_____	_____	_____
_____	_____	_____
_____	_____	_____
_____	_____	_____
_____	_____	_____
_____	_____	_____

Dollar threshold used to determine Type A programs \$
Auditee qualified as low-risk auditee? yes no

TOWNSHIP OF DELANCO SCHOOL DISTRICT
Schedule of Findings and Questioned Costs
For the Fiscal Year Ended June 30, 2016

Section 1- Summary of Auditor's Results (Cont'd)

State Financial Assistance

Internal control over major programs:

Material weakness(es) identified? yes no

Significant deficiency(ies) identified? yes none reported

Type of auditor's report issued on compliance for major programs Unmodified

Any audit findings disclosed that are required to be reported in accordance with New Jersey Circular 15-08-OMB? yes no

Identification of major programs:

<u>GMIS Number(s)</u>	<u>Name of State Program</u>
<u>495-034-5120-078</u>	<u>State Aid - Public Cluster: Equalization Aid</u>
<u>495-034-5120-089</u>	<u>Special Education Categorical Aid</u>
<u>495-034-5120-084</u>	<u>Security Aid</u>
<u>495-034-5120-097</u>	<u>Per Pupil Growth Aid</u>
<u>495-034-5120-098</u>	<u>PARCC Readiness Aid</u>

Dollar threshold used to determine Type A programs \$750,000.00

Auditee qualified as low-risk auditee? yes no

DELANCO TOWNSHIP SCHOOL DISTRICT
Schedule of Findings and Questioned Costs
For the Fiscal Year Ended June 30, 2016

Section 2- Schedule of Financial Statement Findings

This section identifies the significant deficiencies, material weaknesses, and instances of noncompliance related to the financial statements that are required to be reported in accordance with *Government Auditing Standards* and with audit requirements as prescribed by the Division of Administration and Finance, Department of Education, State of New Jersey.

No Current Year Findings.

DELANCO TOWNSHIP SCHOOL DISTRICT
Schedule of Findings and Questioned Costs
For the Fiscal Year Ended June 30, 2016

Section 3- Schedule of Federal Award Findings and Questioned Costs

This section identifies the significant deficiencies, material weaknesses, and instances of noncompliance, including questioned costs, related to the audit of major Federal programs, as required by Title 2 U.S. Code of Federal Regulations Part 200, *Uniform Administrative Requirements, Cost Principles, and Audit Requirements for Federal Awards* (Uniform Guidance).

This section Not Applicable.

DELANCO TOWNSHIP SCHOOL DISTRICT
Schedule of Findings and Questioned Costs
For the Fiscal Year Ended June 30, 2016

Section 4- Schedule of State Financial Assistance Findings and Questioned Costs

This section identifies the significant deficiencies, material weaknesses, and instances of noncompliance, including questioned costs, related to the audit of major State programs, as required by State of New Jersey Circular 15-08-OMB.

No Current Year Findings.

DELANCO TOWNSHIP SCHOOL DISTRICT
Summary Schedule of Prior Year Audit Findings
and Questioned Costs as Prepared by Management

This section identifies the status of prior year findings related to the financial statements and federal awards and state financial assistance that are required to be reported in accordance with *Government Auditing Standards*, Title 2 U.S. Code of Federal Regulations Part 200, *Uniform Administrative Requirements, Cost Principles, and Audit Requirements for Federal Awards* (Uniform Guidance), and State of New Jersey Circular 15-08-OMB.

FINANCIAL STATEMENT FINDINGS

No Prior Year Findings.

FEDERAL AWARDS

This Section Not Applicable.

STATE FINANCIAL ASSISTANCE PROGRAMS

No Prior Year Findings.

