



State of New Jersey
 THE PINELANDS COMMISSION
 PO Box 359
 NEW LISBON, NJ 08064
 (609) 894-7300
 www.nj.gov/pinelands



MIKIE SHERRILL
 Governor
 DR. DALE G. CALDWELL
 Lt. Governor

General Information: Info@pinelands.nj.gov
 Application Specific Information: AppInfo@pinelands.nj.gov

LAURA E. MATOS
 Chair
 SUSAN R. GROGAN
 Executive Director

NEW JERSEY PINELANDS COMMISSION MEETING AGENDA
 Friday, May 8, 2026 - 9:30 a.m.

This meeting will be held in-person and virtually.

Richard J. Sullivan Center for Environmental Policy and Education
 Terrence D. Moore Conference Room
 15C Springfield Road
 New Lisbon, New Jersey

Watch the meeting on the Pinelands Commission YouTube channel via the following link:

<https://www.youtube.com/live/t71T901B4e4?si=cOBdeezFSSPb0VBJ>

To Provide Public Comment, Please Dial: 1-929-205-6099 Meeting ID: 853 6404 0786

1. Call to Order

- Open Public Meetings Act Statement
- Roll Call
- Pledge Allegiance to the Flag

2. Adoption of Minutes

- April 10, 2026 (open and closed)

3. Committee Chairs' and Executive Director's Reports

4. Matters for Commission Consideration *Where the Record is Closed*

A. Permitting Matters

- Office of Administrative Law
 - None
- Review of Local Approvals
 - None
- Public Development Projects and Waivers of Strict Compliance:

Resolution Approving With Conditions (2) Applications for Public Development:

- Application No. 1986-0122.027 - State of NJ Department of Human Services, New Lisbon Developmental Center
Installation of 142 linear feet of sanitary sewer main at the New Lisbon Developmental Center
Woodland Township
- Application No. 1987-0345.021 - Lenape Regional High School District
Paving of an approximately 30,000 square foot existing gravel parking lot
Medford Township

B. Planning Matters

- Municipal Master Plans and Ordinances
 - Issuing an Order to Certify Monroe Township's 2025 Housing Element and Fair Share Plan and Ordinance O:06-2026, adopting the Hightop Redevelopment Plan
- Other Resolutions
 - None
- CMP Amendments
 - None

5. Public Comment on Public Development Applications and Waivers of Strict Compliance *Where the Record is Not Closed*

A. Public Development Projects

- Application No. 1991-0320.005 – Mullica Township
Construction of a 3,300 square foot addition to the Township Municipal Building
Mullica Township
- Application No. 2001-0430.005 – Burlington County
Construction of a roundabout at the intersection of Stokes Road and Willow Grove Road
Shamong Township
- Application No. 2019-0060.001 – Atlantic County Department of Regional Planning
Replacement of a bridge and dam, both associated with the Egg Harbor City Lake, within the Route 563 right-of-way
Egg Harbor City
- Application No. 2020-0085.002 – Egg Harbor Township MUA
Installation of 960 linear feet of sanitary sewer main within the Delilah Road right-of-way

Egg Harbor Township

B. Waiver of Strict Compliance

- None

6. Master Plans and Ordinances Not Requiring Commission Action

- Barnegat Township Ordinance 2026-5
- Corbin City Ordinance 3-2026
- Evesham Township 2026 Housing Element and Fair Share Plan
- Evesham Township Ordinance 11-3-2026
- Hamilton Township Ordinances 2128-2026 and 2129-2026
- Hammonton Town Ordinance 2-2026
- Manchester Township Ordinances 26-21, 26-22, 26-25, and 26-28
- Monroe Township Ordinances O:20-2026 and O:25-2026
- Ocean Township Ordinances 2026-7 and 2026-8
- Pemberton Township Ordinance 13-2026
- Stafford Township Ordinances 2026-02 and 2026-03
- Upper Township Ordinance 001-2026
- Waterford Township Ordinance 2026-12

7. General Public Comment

8. Resolution to Retire into Closed Session (if needed) – Personnel, Litigation and Acquisition Matters. *(The Commission reserves the right to reconvene into public session to take action on closed session items.)*

9. Adjournment

Upcoming Meetings	
Fri., May 29, 2026	Policy & Implementation Committee Meeting (9:30 a.m.)
Fri., June 12, 2026	Pinelands Commission Meeting (9:30 a.m.)

To ensure adequate time for all members of the public to comment, we will respectfully limit comments to **three minutes**. Questions raised during this period may not be responded to at this time but where feasible, will be followed up by the Commission and its staff.

Pinelands Commission and Committee meeting agendas are posted on the Commission's Website and can be viewed at www.nj.gov/pinelands/ for more information on agenda details, e-mail the [Public Programs Office](mailto:PublicProgramsOffice@pinelands.nj.gov) at Info@pinelands.nj.gov.

PINELANDS COMMISSION MEETING

MINUTES
April 10, 2026

All participants were either in-person or present via Zoom conference and the meeting was livestreamed through YouTube: <https://www.youtube.com/watch?v=6sNmcQ3pJiM>

Commissioners Participating in the Meeting

Nicholas Asselta, Alan W. Avery Jr., Deborah Buzby-Cope, Jerome H. Irick, Mark Lohbauer, Gaetano Matro, Mark Mauriello, Jonathan Meade, William Pikolycky, Jessica Rittler Sanchez, Ryck Signor, and Douglas Wallner. Also participating were Executive Director Susan R. Grogan, Deputy Attorney General (DAG) Jay Stypinski and Governor's Authorities Unit representative Azeem Chaudry.

Commissioners Absent

Theresa Lettman & Laura E. Matos.

Call to Order

Vice Chair Avery called the meeting to order at 9:30 a.m.

DAG Stypinski read the Open Public Meetings Act Statement (OPMA).

Executive Director (ED) Grogan called the roll and announced the presence of a quorum. Twelve Commissioners participated in the meeting. Commissioner Meade joined the meeting late.

The Commission pledged allegiance to the Flag.

Minutes

Vice Chair Avery presented the minutes from the Commission's March 13, 2026 meeting. Commissioner Lohbauer moved the adoption of the minutes. Commissioner Matro seconded the motion.

The minutes from the March 13, 2026 Commission meeting were adopted by a vote of 11 to 0.

Committee Reports

Vice Chair Avery provided an update on three Committee meetings:

- The Personnel & Budget Committee met on March 17, 2026. The Committee adopted the minutes from its August 19, 2025 meeting. Staff reviewed financial updates, including check registers, electronic disbursements, and application fees and provided a summary of recent employee actions. The Committee approved the deletion of fixed assets. Finally, the Committee went into closed session to discuss bids received for the Fenwick Manor Rehabilitation Project and the Executive Director's recommendation. A resolution authorizing the Executive Director to execute a contract with the selected contractor will be on the April 10, 2026 Commission meeting agenda.
- The Audit Committee met on March 20, 2026 and reviewed the FY2022 Audit report issued by the State Auditor. The Committee discussed the two findings in the report. Staff provided details regarding the planned implementation of corrective actions in response to the two findings. Committee members provided several suggestions to prepare for future audits.
- The Policy and Implementation (P&I) February 27, 2026 meeting. The Committee received a presentation on Pinelands Conservation Fund stewardship monitoring. Staff summarized their findings after visiting five PCF funded sites this winter. They noted that these sites are some of the earliest PCF funded sites and that the sites are in good condition. The Committee also heard a presentation on AI Data Center Development and the Pinelands Regulatory Context. The presentation covered background information on AI data centers, emerging trends, and summarized the Commission's regulations that would apply to municipal zoning for data centers and standards for any development application for an AI data center. The Committee discussed other potential strategies or issues related to data center development in the Pinelands Area.

Executive Director's Report

ED Grogan provided information on the following matters:

- On today's agenda is a resolution to award the contract for the Fenwick Manor rehabilitation project so the actual work that we have been discussing for the last few years can finally get underway.

- The Science office recently submitted a grant proposal to the National Fish and Wildlife Foundation, entitled: Research, monitoring and decision tools for reptiles of greatest conservation need. The research will focus on the following species: box turtles, pine snakes and – for the first time – timber rattlesnakes related to their surface area activity during specific time periods. The data will assist the Regulatory Programs office when reviewing applications for enduro events and forestry activities, as well as providing guidance on vegetation management and prescribed burning. The Science Office is also working on another grant proposal to the Environmental Protection Agency related to the 300-foot buffer to wetlands and if the buffer provides enough protection to wetlands species.
- Two new employees, a Business Assistant and an Environmental Specialist, will begin on Monday, April 13th and will be introduced at the May Commission meeting.
- Approximately 10 years ago, the Commission approved a compelling public need waiver for the construction of a stormwater basin in the Pinelands Forest Area of Stafford Township. Grant funding has finally become available and the project will be proceeding. As part of the compelling public need waiver, an offsetting measure is required. The applicant, in this case Stafford Township, had the option of purchasing and redeeming Pinelands Development Credits (PDCs), preserving land in the Pinelands Area or providing a monetary contribution to the Pinelands Conservation Fund (PCF). The Township will be providing the required monetary contribution shortly.

Chuck Horner, Director of Regulatory Programs, provided information on the following regulatory matters:

- On March 16th, staff met with consultants for the Winzinger organization to discuss threatened and endangered species information. The applicant is proposing to mine four areas, totaling 75 acres, of its Woodland Township property.
- On March 25th, staff met with representatives of Maurice River Township, which is proposing to develop a solar energy facility on its closed but uncapped landfill. Staff provided details about the type of cap that would be necessary, either impermeable or permeable, and shared information related to threatened and endangered species. The solar facility developer advised the Commission that land clearing must commence by June 1, 2026.
- Staff recently issued a letter to an applicant who converted a farm market into a restaurant without application to the Commission. A copy of the letter was shared with Commissioners at the beginning of the meeting. The restaurant, Sweet Amalia, is located in Franklin Township, Gloucester County. A stone patio providing expanded outdoor seating, was also constructed without application. In 2023, Commission staff held a pre-application meeting with the applicant. At that meeting, staff advised that having a restaurant on a small lot is challenging due to the Pinelands Comprehensive Management Plan (CMP) septic dilution standard. The CMP requires that all development served by an

on-site septic system meet the groundwater quality standard of two-parts per million nitrogen. The applicant is proposing to gain additional acreage by purchasing an adjacent parcel that contains an ice cream stand that is no longer in use. The Commission has asked for information to determine the wastewater flows that pre-existed adoption of the CMP in order to determine that the current use won't worsen the groundwater quality. The matter is resolvable with the installation of an alternate design wastewater system, which treats the wastewater; however, the system is expensive to install.

Commissioner Avery asked which Pinelands Management Area the restaurant is in.

Director Horner said the parcel is located in a Pinelands Rural Development Area.

Commissioner Mauriello asked about the Township's position on the application and if permits were issued.

Director Horner said the Township is requiring an application and there is a long history dating back to 2015.

April Field, Chief Permit Administrator, providing the following update:

- At the March Commission meeting, staff shared information related to the chemical treatment of three ponds in Waterford Township to eradicate an invasive fish species, the northern snakehead. Since then, the New Jersey Department of Environmental Protection (NJDEP) revised their application to include two additional ponded areas upstream. On March 18, 2026, Commission staff indicated to NJDEP, Pesticide Control Program, that the proposed chemical treatment of the additional 5.44 acres of ponded areas did not raise any issues with regard to Pinelands regulations and the NJDEP could issue the permit.

Ms. Field shared two CMP related regulations that staff sometimes contend with during the application review process:

Ms. Field explained that any building used exclusively for agriculture does not require an application to the Commission. She said staff spend a great deal of time clarifying what type of development requires an application as it relates to agriculture. She said the establishment of any agricultural products processing facility use on the parcel or within existing or proposed buildings requires completion of an application with the Commission. She said this provision of the CMP comes up often when reviewing an application or inquiry related to cannabis.

Ms. Field said the CMP has a provision that provides that the reconstruction of a single family dwelling within five years of demolition does not require application to the Commission. Once that timeframe has passed, any proposed dwelling on a parcel must meet all current land use, zoning and environmental standards. She said in February 2017, an application for the demolition of an existing dwelling, 50 years old or older, was completed with the Commission and a Certificate of Filing was issued. Sometime between 2017-2018, the dwelling was demolished. In January 2026, an application was submitted proposing the development of a single family dwelling served by a septic system on the 0.25-acre (11,000 square feet) lot. Since

the dwelling was not reconstructed within five years of the demolition of the previously existing dwelling, a new application is required.

She said the CMP requires that single family dwellings served by onsite septic systems be located on lots of at least 1.0 acre. Additionally, septic systems must be located at least 300 feet from wetlands. The proposed development of a dwelling on the lot does not meet the minimum environmental standards to qualify for a Waiver. If a Waiver application is filed and approved by the Commission, the relief granted would be an allocation of PDCs.

Gina Berg, Director of Land Use Programs, provided an update on the following:

- The Department of Agriculture has established a Woodland Easement Purchase program similar to its Farmland Easement Purchase program. Commission staff will participate in the stakeholder process as the new formula is developed to preserve woodlands. The current statewide formula for evaluating farmland easements is based on the special formula developed many years ago for farms in the Pinelands Area. It was largely based on the value of PDCs.
- Staff continue to create a work plan for use of the National Park Service funding for the upcoming federal fiscal year, starting October 1st. The plan will include modernization of an application review system and continuation of long-term environmental monitoring.
- The state's Interagency Council on Climate Resilience sent out a survey to its members seeking input on the future direction of the Council.
- The April 24th P&I Committee meeting agenda will include Monroe Township's Hightop Redevelopment Plan and a presentation on NJDEP's Resilient Environments and Landscapes (REAL) rules related to wetlands permitting in the Pinelands Area.

Commissioner Mauriello said that Senator Bob Smith who chairs the Senate Environmental Committee, is holding a hearing on Earth Day, where a panel of experts will provide testimony on the REAL rules. He also noted Senator Scutari's February 2026 resolution seeking a determination that the REAL rules are inconsistent with legislative intent.

Stacey Roth, Chief, Legal and Legislative Affairs reminded Commissioners that it is time to file Financial Disclosure Statements. She said the deadline to file is May 15, 2026.

Brad Lanute, Chief Planner, provided the following update:

- The Land Use Programs office has been reviewing a number of affordable housing ordinances. Approximately 36 ordinances were submitted in the last month. This aligns with the March 15th deadline for New Jersey municipalities to adopt implementing ordinances of their affordable housing plans. Many of these have been reviewed and found to raise no substantial issue, as noted in this month's memo. Staff anticipates that some will require review and approval by the full Commission, such as the Monroe

Township redevelopment plan that will be going before the P&I Committee later this month.

- Commission staff continued to evaluate materials submitted by Jackson Township in response to concerns identified with the affordable housing sites included in the Township's Housing Element and Fair Share Plan that are located in the Pinelands Area. On March 23, 2026, staff issued a letter to the Township addressing the four affordable housing sites within the Pinelands Area. The letter specifically requested additional information be submitted regarding infrastructure capacity and availability for the sites located in the Regional Growth Area.

Paul Leakan, Communications Officer, said staff is working on the Pinelands Summer Short course, which is scheduled for Friday, July 17th at Kramer Hall in downtown Hammonton. There will be approximately 10 classroom programs and around five field trips.

Commissioner Rittler Sanchez suggested a course on tick identification and prevention.

Public Development Projects and Other Permit Matters

Vice Chair Avery introduced a resolution to approve four public development applications.

Commissioner Pikolycky made a motion Approving With Conditions Applications for Public Development (Application Numbers 1989-0466.016, 1990-1174.012, 2001-0236.004 & 2006-0265.003) (See Resolution # PC4-26-06). Commissioner Mauriello seconded the motion.

The resolution was adopted by a vote of 11 to 0.

Director Horner provided a quick overview of the development applications that the Commissioners voted on. He said Monroe Township is expanding a street hockey rink within an existing municipal park. The NJDEP is demolishing a restroom building and constructing a new restroom at a campground within Belleplain State Forest. Stafford Township is constructing a 49-space paved parking lot within an existing municipal park. He said Monroe Township is constructing an amphitheater and paved parking lot in an existing municipal park.

Commissioner Rittler Sanchez requested that all future public development reports include the change in or amount of impervious cover.

Vice Chair Avery introduced a resolution to approve one public development application.

Commissioner Pikolycky made a motion Approving With Conditions an Application for Public Development (Application Number 1985-0202.008) (See Resolution # PC4-26-07). Commissioner Lohbauer seconded the motion.

Director Horner said the Hamilton Township Board of Education is proposing a building addition to an existing school and an after-the-fact application for a playground that was built

without application to the Commission. The application also includes the removal of a playground expansion that was constructed without application to the Commission.

Commissioner Rittler Sanchez asked for confirmation that there is no artificial turf proposed with this application. She said the Public Development report mentions an irrigation well.

Director Horner said no artificial turf is proposed as part of this application. He said a separate application has been filed with the Commission for the irrigation well.

The resolution was adopted by a vote of 11 to 0.

Commissioner Meade joined the meeting.

Public Comment on Development Applications and Items Where the Record is Open

Director Horner described the two applications. He said a sewer extension is proposed at the New Lisbon Development Center. He said the other application is proposing to pave an existing gravel parking lot at Shawnee High School in Medford.

No one from the public provided comment.

Ordinances Not Requiring Commission Action

Chief Planner Lanute said the majority of ordinances that did not raise a substantial issue are related to affordable housing implementing ordinances.

Other Resolutions

Vice Chair Avery introduced a resolution to accept the Fiscal Year 2022 Audit Report.

Commissioner Lohbauer made a motion To Accept the Fiscal Year 2022 Audit Report (See Resolution # PC4-26-08). Commissioner Pikolycky seconded the motion.

ED Grogan said the FY2022 audit took a long time to complete. The report includes two findings. The first finding is related to internal controls over financial reporting. The second finding is lack of formal written policies for security and data risk assessment related to the Commission's accounting software.

She said staff prepared a letter to the State Auditor that outlined the corrective actions. She provided an update on the staff's progress in completing these actions. A Request for Quotation has been posted for a new accounting firm that will produce specific financial records in preparation for the next audit and ensure internal controls are being followed. A new Business Assistant has been hired to help with the Business Office's workload, which should provide the Business Manager with more time to focus on audit matters. In response to the second finding, staff have already prepared and posted the Commission's internal formal written policies for user

access policy, risk assessment, security plan and segregation of duties related to the Edmunds Accounting System.

ED Grogan said the Commission will be in a better place when the State Auditor contacts the Commission about beginning the FY2023 Audit.

The resolution was adopted by a vote of 12 to 0.

Vice Chair Avery introduced a resolution to award a contract for the Fenwick Manor Rehabilitation project.

Commissioner Lohbauer made a motion To Authorize the Executive Director to Enter into a Contract for Construction Services for the Historic Fenwick Manor Rehabilitation Project (See Resolution # PC4-26-09). Commissioner Rittler Sanchez seconded the motion.

Marc Paalvast, Cultural Resource Specialist, said the Fenwick Manor project includes two main components: foundation stabilization and exterior renovations. The two front chimneys are sinking and have caused significant cracks in the surrounding walls. He said in 2004, during the last major renovation of Fenwick Manor, the HVAC system was trenched in the crawl space of the building. Some of those trenches were dug too close to the foundation of the chimneys. Ultimately, this caused slow erosion and no support for the chimneys, which has led to the sinking. In order to stabilize the chimney, the contractor plans to excavate soil from underneath the foundations in sections and then fill those sections with concrete. A helical pile method will be used to provide structural support. He noted that during the excavation, there is a requirement for an archaeological monitor to be present. He said he will be handling this task. During the excavation, the soils from under the chimney will be evaluated using a shaker screen. Any artifacts that may be discovered will be reported to the historic trust. He said the mortar surrounding the brick and stone foundations will also be repaired. He then provided the detail of the exterior improvements, most notably the removal of peeling paint and preparing the building for fresh paint. The drainage plan will feed water away from the building into two newly constructed dry wells.

Mr. Paalvast reviewed the funds allocated to the project. The Hawley Bros. bid came in slightly under budget, which provides contingency funds of approximately \$200,000. Connolly & Hickey submitted our permit application to the Department of Community Affairs in March. The staff expects to execute the contract in early May. The notice to proceed will be provided shortly after that. According to the bid, the contractor has estimated to complete the work within 150 days of the notice to proceed, which brings us to around October when we expect that staff can move back into Fenwick Manor. See attached presentations slides.

ED Grogan noted that although the permit with the DCA has been filed, we don't know when it will be issued and that could cause a delay. The Commission is waiting to find out how much the permit fee will be.

Commissioner Pikolycky asked why the Commission is paying a permit fee. He said we should request a waiver. He said municipalities requests waivers all the time.

ED Grogan noted that the Commission has had to pay permit fees in the past but staff will look into the possibility of a waiver.

Commissioner Irick asked if there will be any regrading around Fenwick Manor.

ED Grogan said we will ask the design consultants.

Vice Chair Avery asked for assurance that any allowances in the bid will be approved by the Executive Director. ED Grogan said that will definitely be made clear in the contract.

The resolution was adopted by a vote of 12 to 0.

General Public Comment

Edward Pappas, owner of Sweet Amalia in Franklin Township, explained the difficulties and challenges that his small business has faced trying to navigate through the Commission's application process. He said he believes he has found both an interim and long-term solution in order for the restaurant to continue business. He would like the opportunity to meet with staff (see attached written comments).

Melissa McGrath, chef and owner of Sweet Amalia Kitchen in Franklin Township, shared the significance of the local South Jersey oyster industry. She said she understands the importance of the rules but the process has been convoluted and has had a negative effect on the restaurant's customers, employees, and finances. She also requested the opportunity to meet with Commission staff and find a path forward (see attached written comments).

Heidi Yeh of the Pinelands Alliance said the issue with Sweet Amalia Kitchen is a miscommunication. She said a number of changes occurred over the last three years and the details have not been available. She said the Commission is understaffed and the Legislature should prioritize the Commission by providing additional funding. She said the Commission should focus on a more egregious violation in Franklin Township in which the property owner clear cut 15 acres.

Resolution to retire in Closed Session

DAG Stypinski read the closed session resolution. Commission Lohbauer made a motion to enter closed session. Commissioner Buzby-Cope seconded the motion. All were in favor. The Commission entered closed session at 10:53 a.m.

Return to Open Session

Ms. Roth said that during closed session, the Commission was briefed on a litigation matter and the costs associated with the litigation. No action was taken during closed session.

Director Horner said April Field spoke with the owners of Sweet Amalia. They will be in contact with their consultants to request that they provide the necessary substantive information and then we will hold a meeting.

Adjournment

Commissioner Pikolycky moved to adjourn the meeting. Commissioner Lohbauer seconded the motion. The Commission agreed to adjourn at 11:40 a.m.

Certified as true and correct:

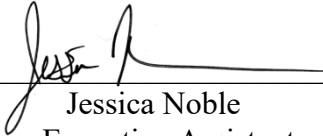

Jessica Noble
Executive Assistant

Date: April 16, 2026

Fenwick Manor Rehabilitation and Stabilization

New Jersey Pinelands Commission Meeting
April 10, 2026



Scope of work

Foundation Stabilization

- Two front chimneys
- Brick piers
- Brick and stone foundations - mortar repair

Exterior Renovations

- Painting
 - paint removal,
 - surface prep/repair, and
 - repainting
- Window/shutter repair
- Improved drainage system
- Roofing

Foundation Stabilization



Trenches dug for HVAC in crawl space caused erosion under foundation



Cracks in wall due to slumping chimney

Inside fireplace showing slumping



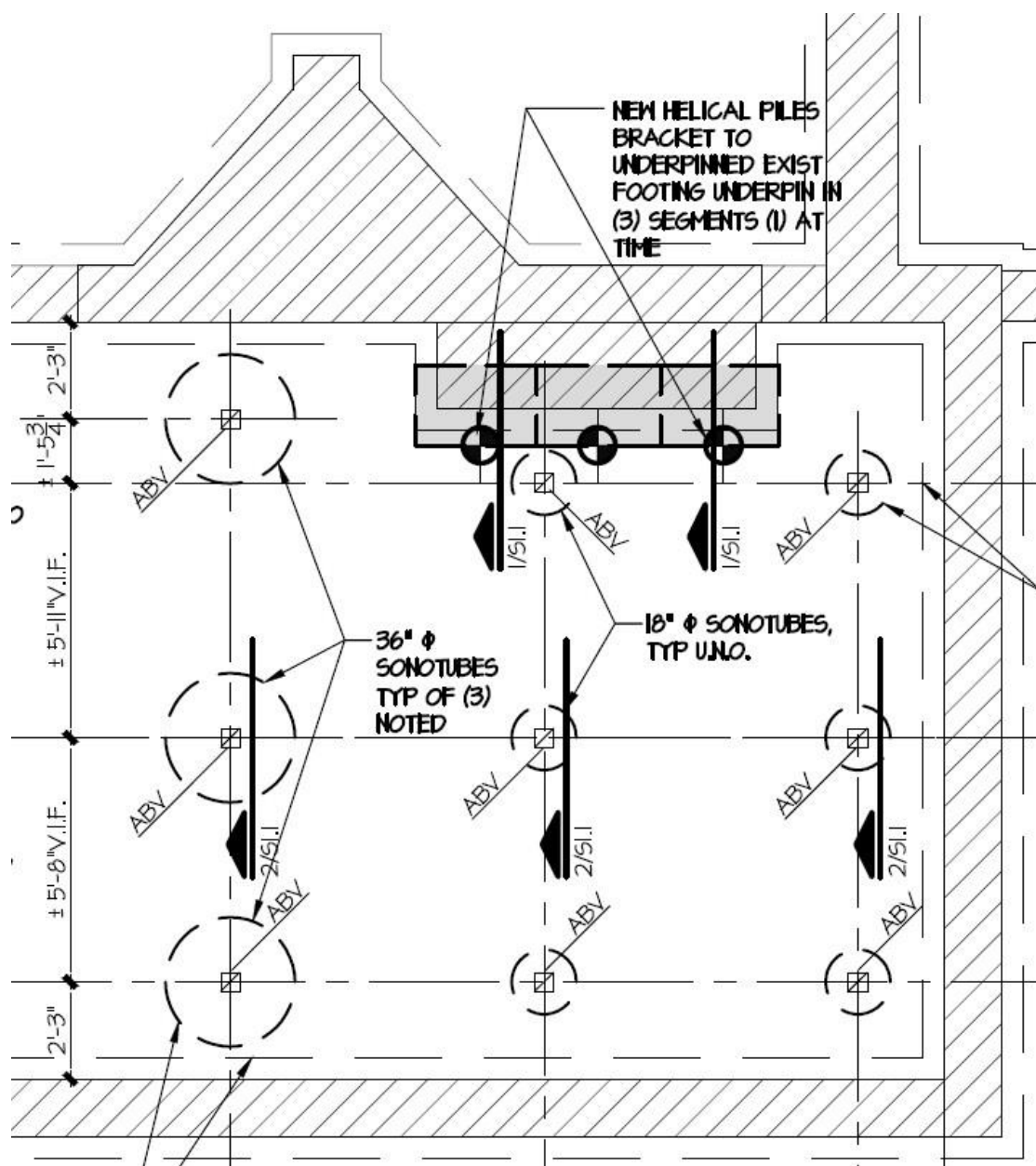

Chimney Foundation Plan

EXIST BRICK CHIMNEY TO REMAIN
 EXIST CONCRETE FOOTING, V.I.F.
 #5 BARS AT 12" O.C. EA WAY. HORIZ BARS SHOULD BE DOWELED INTO ADJACENT SECTIONS W/ 4" HILTI HY 200 EPOXY

HELICAL PIER BRACKET, RE: SCHED ON DETAIL 5 THIS SHEET. PROVIDE (4) 1/2" ϕ EXPANSION BOLTS W/ 4" EMBEDMENT TO FOOTING

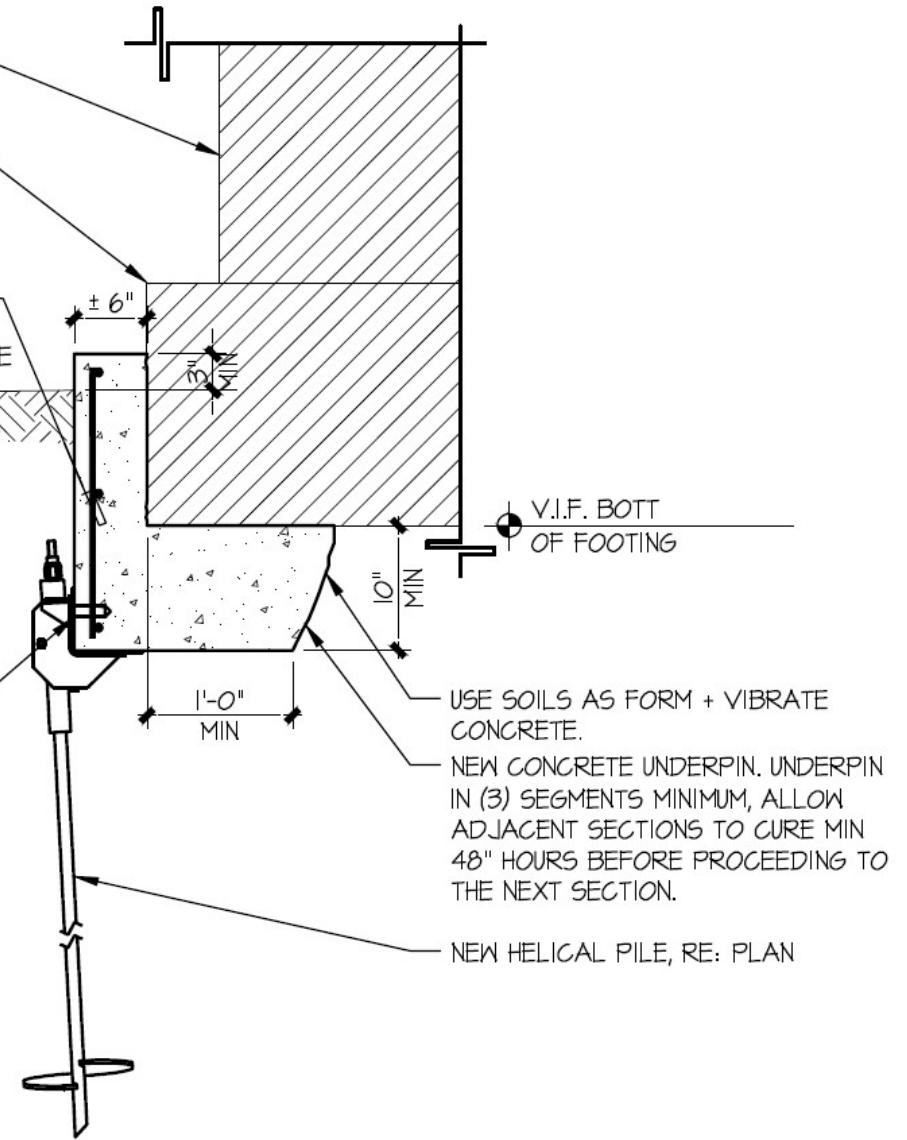

Helical Pile Design



Stone foundation mortar repair

Brick foundation mortar repair



Exterior Renovations



Front street view of Fenwick Manor

Wholesale peeling of paint





Repair and repaint windows/shutters and hardware replacement

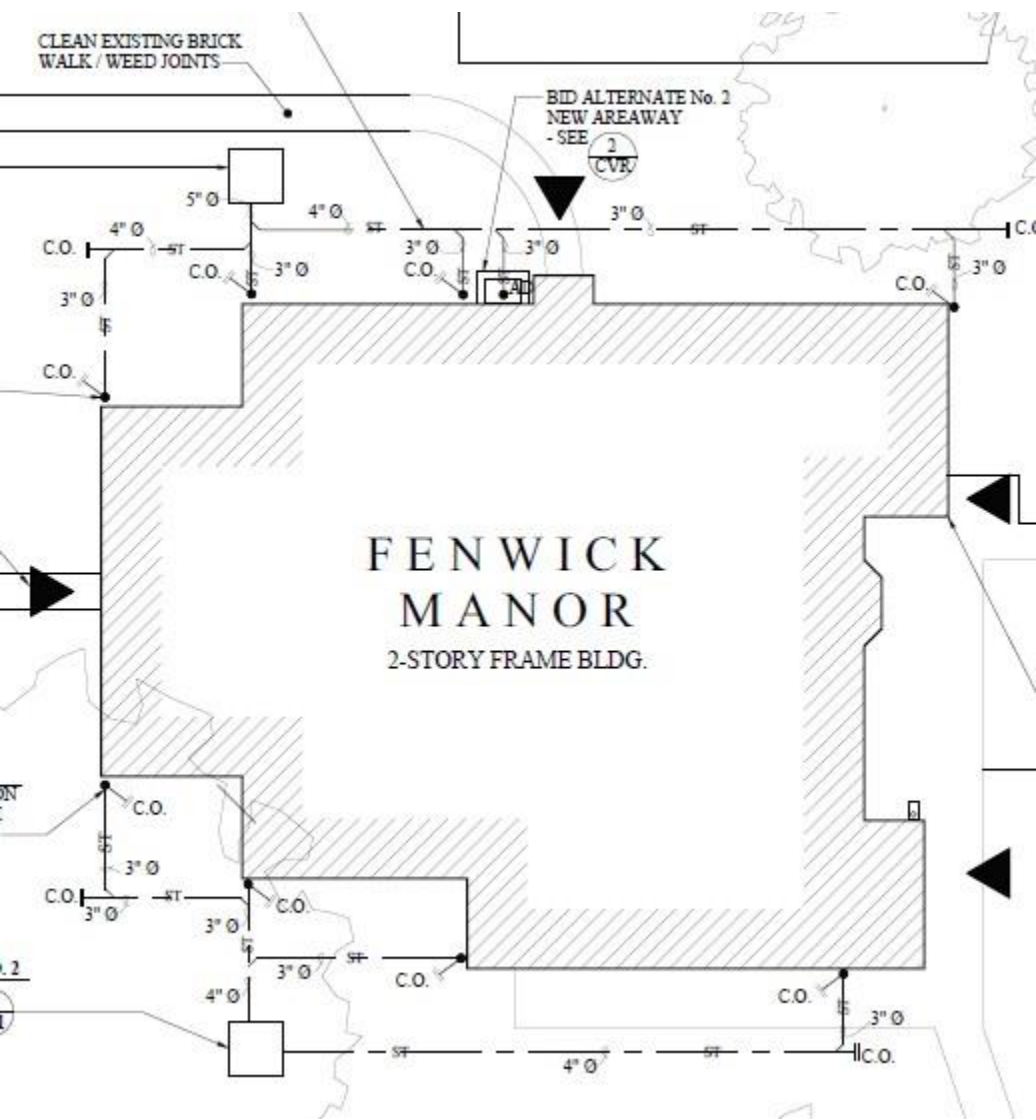

Underground drainage plans

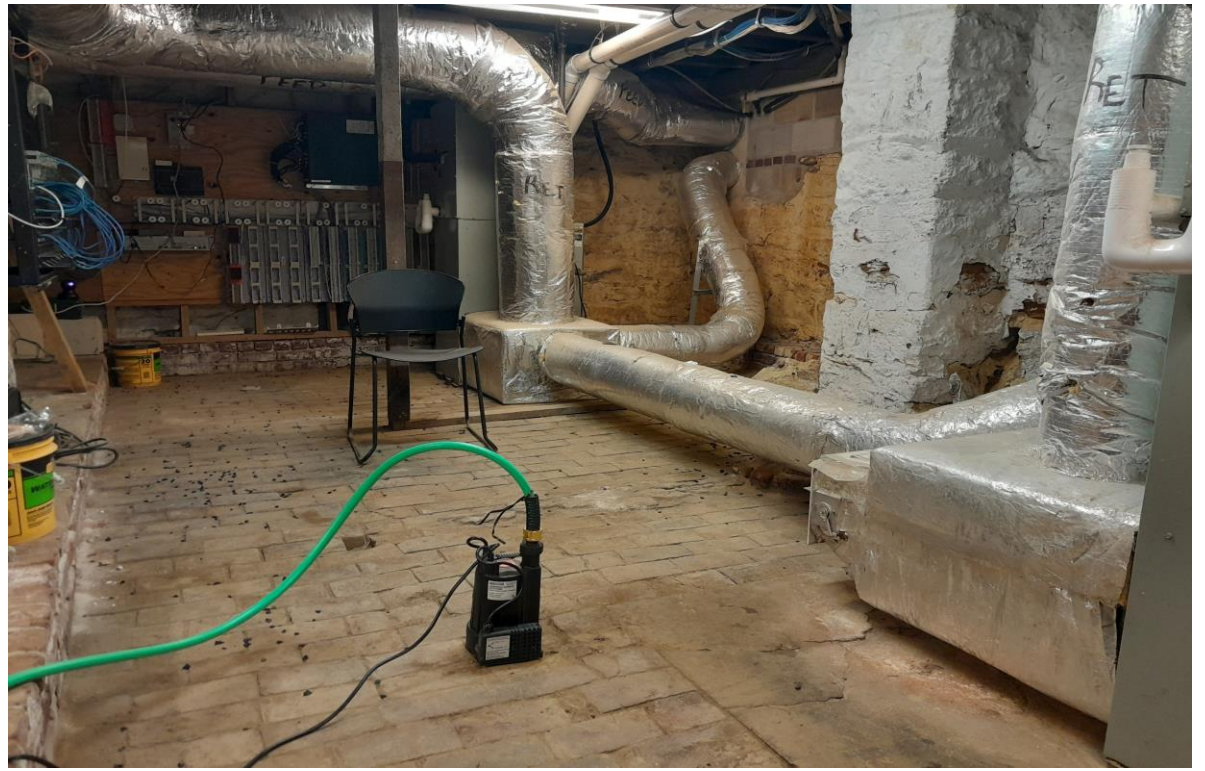

Submersible pump in basement

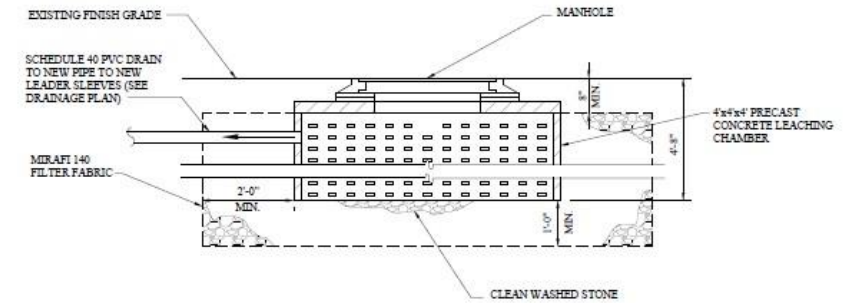
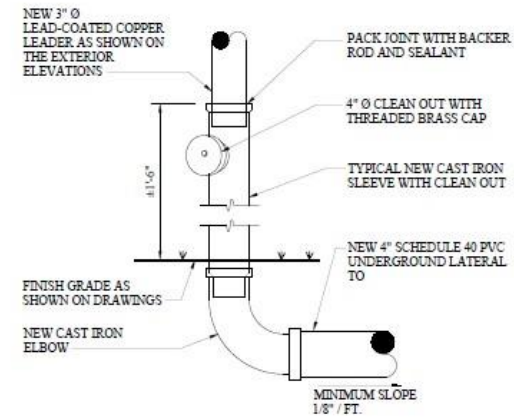

Hawley Bros Bid

Base Bid:	
General Req's	\$69,200.00
Temporary Facilities	\$6,400.00
Division 2 - Existing Conditions	\$16,732.00
Division 3 - Concrete	\$90,902.00
Division 4 - Masonry	\$78,900.00
Division 5 - Metals	\$7,800.00
Division 6 - Woods and Plastics	\$113,806.00
Division 7 - Thermal and Moisture Protection	\$158,650.00
Division 8 - Doors and Windows	\$79,950.00
Division 9 - Finishes	\$213,040.00
Division 10 - Specialties (Signs)	\$3,680.00
Division 23 - Heating, Ventilating, and Air Conditioning (HVAC)	\$33,985.00
Division 32 - Exterior Improvements (Drainage)	\$56,275.00
General Contingency Allowance	\$15,000.00
Allowances Per Drawings	\$10,000.00
Calculated Total:	\$954,320.00

Available Funds

Funding Source	Available Funds	Consultant/Contractor	Cost
NJ Historic Trust Capital Grant	\$575,000	Connolly & Hickey	\$102,100
		Hawley Bros	\$954,320
FY23 State Appropriation	\$500,000	Total Costs	\$1,056,420
FY26 State Appropriation	\$69,000	Totals	
Fenwick Manor Painting Reserve Fund	\$120,000	Total Available Funds	\$1,264,000
		Total Costs	\$1,056,420
Total Available Funds	\$1,264,000	Total Remaining Funds	\$207,580

Project Timeline

- March 17th – Personnel and Budget Committee meeting
- March 18th – Notice of Intent to Award
- April 10th – Pinelands Commission meeting
- Late April – Contract and building preparation
- Early May – Contract execution
- May – Notice to Proceed, upon acquisition of all necessary DCA permits (permit application submitted to DCA in late March)
- October – Construction completion within 150 days of Notice to Proceed

Thank you!

Questions?

Good morning Chair, Commissioners, and staff of the Pinelands Commission,

My name is Ed Pappas and I'm one of the owners of Sweet Amalia in Franklin Township. Thank you for the opportunity to speak today.

We fully understand—and respect—the Commission's mission to protect the New Jersey Pine Barrens and its sensitive groundwater resources. That's why, since 2023, we have worked in good faith with engineers, your staff and invested significant time and resources to bring our project into full compliance.

Over the past three years, we've explored every available option. We attempted to secure additional land for septic dilution, but that agreement ultimately fell through late last year. We evaluated advanced septic technologies, including systems operating at the very edge of their design capabilities, but at costs exceeding \$500,000 for a small, seasonal business, those options are simply not financially viable at this time.

In response, we had revised our application again—this time proposing a more conservative approach that reduces nitrogen impacts compared to historical conditions. By reallocating existing flows and scaling our operation down to approximately 22 seats, we believed we had put forward a practical, environmentally responsible path that allows us to reopen while continuing to gather data and financial support for a longer-term solution.

We believe we have a workable path forward for an interim plan that would lead to a final plan that meets the 2ppm nitrate standard. It would be extremely helpful to have the opportunity to sit down and discuss the project with Pineland's staff to hammer out a path forward.

We have now been in this process for more than three years. During that time, we have spent tens of thousands of dollars on engineering, application fees, and revisions, all while being unable to fully operate. Each delay—whether due to evolving plans,

technical clarifications, or review timelines—has real consequences for our small business, our employees, and our customers.

We are not asking for special treatment. We are simply asking for clarity, consistency, and a path forward.

Sweet Amalia has become a destination for many people traveling through South Jersey. We want to continue serving our community—but we can only do so if we are able to operate within a predictable and timely regulatory process.

We remain committed to meeting the Commission's standards and protecting the Pinelands. We just need a process that allows us to get there.

Thank you for your time and consideration.

Melissa's

Good morning Chair, Commissioners, and staff of the Pinelands Commission,

My name is Melissa McGrath and I'm also an owner of Sweet Amalia. I want to take a moment to share what this place means—to us, and to the broader community.

Sweet Amalia started as something very simple: a small farm market, a few tables, and a passion for oysters and local food. We built it ourselves, step by step, into a place where people could stop, gather, and experience something uniquely South Jersey. Over time, it became more than just a restaurant. It became a destination—somewhere people would drive out of their way to visit on their way to the Shore, a place that celebrated the region's landscape, agriculture, and waters.

We've been proud to be part of the growing food scene in South Jersey, and especially to support local farms and the oyster industry. At the heart of our business is an oyster farm. Oysters are one of the most sustainable forms of aquaculture—they actually improve water quality—and we've worked hard to highlight local growers and connect people to that story. For many of our customers, Sweet Amalia is their first experience with oysters from this region.

This business is deeply personal to us. It represents years of work, risk, and commitment—not just financially, but emotionally. It's also supported a team of employees and contributed to a local economy that depends on small, independent businesses like ours.

That's why this situation is so difficult. We understand the importance of the rules, and we are committed to meeting them. But the length and uncertainty of this process has put everything we've built at risk. Each year we remain closed is not just a pause—it's a loss of momentum, of staff, of customers, and of the role we've been able to play in the community.

It's hard to watch something that has brought so much value—to diners, to local producers, and to the region—become uncertain, not because a solution is out of reach, but because the path to approval has been convoluted and taken so long.

We would like the opportunity to sit down and discuss our project with your staff and collaboratively identify a path that allows us to operate consistent with Pineland's regulations.

We are here because we want to keep doing this work. We want to reopen, even in a reduced capacity, and continue building something that reflects the best of South Jersey.

We just need the opportunity to move forward.

Thank you for listening.

Good morning Chair, Commissioners, and staff of the Pinelands Commission,

My name is Melissa McGrath and I'm also an owner of Sweet Amalia. I want to take a moment to share what this place means—to us, and to the broader community.

Sweet Amalia started as something very simple: a small farm market, a few tables, and a passion for oysters and local food. We built it ourselves, step by step, into a place where people could stop, gather, and experience something uniquely South Jersey. Over time, it became more than just a restaurant. It became a destination—somewhere people would drive out of their way to visit on their way to the Shore, a place that celebrated the region's landscape, agriculture, and waters.

We've been proud to be part of the growing food scene in South Jersey, and especially to support local farms and the oyster industry. At the heart of our business is an oyster farm. Oysters are one of the most sustainable forms of aquaculture—they actually improve water quality—and we've worked hard to highlight local growers and connect people to that story. For many of our customers, Sweet Amalia is their first experience with oysters from this region.

This business is deeply personal to us. It represents years of work, risk, and commitment—not just financially, but emotionally. It's also supported a team of employees and contributed to a local economy that depends on small, independent businesses like ours.

That's why this situation is so difficult. We understand the importance of the rules, and we are committed to meeting them. But the length and uncertainty of this process has put everything we've built at risk. Each year we remain closed is not just a pause—it's a loss of momentum, of staff, of customers, and of the role we've been able to play in the community.

It's hard to watch something that has brought so much value—to diners, to local producers, and to the region—become uncertain, not because a solution is out of reach, but because the path to approval has been convoluted and taken so long.

We would like the opportunity to sit down and discuss our project with your staff and collaboratively identify a path that allows us to operate consistent with Pineland's regulations.

We are here because we want to keep doing this work. We want to reopen, even in a reduced capacity, and continue building something that reflects the best of South Jersey.

We just need the opportunity to move forward.

Thank you for listening.



RESOLUTION OF THE NEW JERSEY PINELANDS COMMISSION

NO. PC4-26-06

TITLE: **Approving With Conditions Applications for Public Development** (Application Numbers 1989-0466.016, 1990-1174.012, 2001-0236.004 & 2006-0265.003)

Commissioner Pikolycky moves and Commissioner Mauriello seconds the motion that:

WHEREAS, the Pinelands Commission has reviewed the Public Development Application Reports and the recommendation of the Executive Director that the following applications for Public Development be approved with conditions:

1989-0466.016

Applicant: NJDEP, Office of Resource Development
Municipality: Dennis Township
Management Area: Pinelands Forest Area
Date of Report: March 17, 2026
Proposed Development: Demolition of a restroom building, 50 years old or older, and the construction of a restroom building;

1990-1174.012

Applicant: Monroe Township
Municipality: Monroe Township
Management Area: Pinelands Regional Growth Area
Date of Report: March 16, 2026
Proposed Development: Expansion of a street hockey rink within an existing Township park;

2001-0236.004

Applicant: Township of Monroe
Municipality: Monroe Township
Management Area: Pinelands Regional Growth Area
Date of Report: March 16, 2026
Proposed Development: Construction of amphitheater and a 148 space paved parking lot within an existing Township park; and

2006-0265.003

Applicant: Stafford Township
Municipality: Stafford Township
Management Area: Pinelands Regional Growth Area
Date of Report: March 16, 2026
Proposed Development: Construction of a 49 space paved parking lot within an existing Township park.

WHEREAS, no request for a hearing before the New Jersey Office of Administrative Law regarding the Executive Director’s recommendation has been received for any of these applications; and

WHEREAS, the Pinelands Commission hereby adopts the Conclusion of the Executive Director for each of the proposed developments; and

WHEREAS, the Pinelands Commission hereby determines that each of the proposed developments conform to the standards for approving an application for public development set forth in N.J.A.C. 7:50-4.57 of the Pinelands Comprehensive Management Plan if the conditions recommended by the Executive Director are imposed; and

WHEREAS, pursuant to N.J.S.A. 13A-5h, no action authorized by the Commission shall have force or effect until ten (10) days, Saturdays, Sundays and public holidays excepted, after a copy of the minutes of the meeting of the Commission has been delivered to the Governor for review, unless prior to expiration of the review period the Governor shall approve same, in which case the action shall become effective upon such approval.

NOW, THEREFORE BE IT RESOLVED that Application Numbers 1989-0466.016, 1990-1174.012, 2001-0236.004 & 2006-0265.003 for public development are hereby **approved** subject to the conditions recommended by the Executive Director.

Record of Commission Votes

	AYE	NAY	NP	A/R*		AYE	NAY	NP	A/R*		AYE	NAY	NP	A/R*
Asselta	X				Lohbauer	X				Rittler Sanchez	X			
Avery	X				Matro	X				Signor	X			
Buzby-Cope	X				Mauriello	X				Wallner	X			
Irick	X				Meade			X		Matos			X	
Lettman			X		Pikolycky	X								

*A = Abstained / R = Recused

Adopted at a meeting of the Pinelands Commission

Date: April 10, 2026

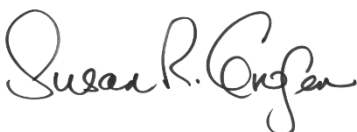

Susan R. Grogan
Executive Director



Alan W. Avery, Jr.
Vice Chair



State of New Jersey

THE PINELANDS COMMISSION

PO Box 359

NEW LISBON, NJ 08064

(609) 894-7300

www.nj.gov/pinelands



MIKIE SHERRILL
Governor

DR. DALE G. CALDWELL
Lt. Governor

General Information: Info@pinelands.nj.gov
Application Specific Information: AppInfo@pinelands.nj.gov

LAURA E. MATOS
Chair

SUSAN R. GROGAN
Executive Director

March 17, 2026

John Cecil, Assistant Commissioner (via email)
New Jersey Department of Environmental Protection, Office of Resource Development
501 East State Street
Trenton NJ 08625-0420

Re: Application # 1989-0466.016
Block 48, Lot 1
Dennis Township

Dear Mr. Cecil:

The Commission staff has completed its review of this application for the demolition of a restroom building, 50 years old or older, and the construction of a restroom building. Enclosed is a copy of a Public Development Application Report. On behalf of the Commission's Executive Director, I am recommending that the Pinelands Commission approve the application with conditions at its April 10, 2026 meeting.

Any interested party may appeal this recommendation in accordance with the appeal procedure attached to this document. If no appeal is received, the Pinelands Commission may either approve the recommendation of the Executive Director or refer the application to the New Jersey Office of Administrative Law for a hearing.

Prior to any development, the applicant shall obtain any other necessary permits and approvals.

Sincerely,

Charles M. Horner, P.P.
Director of Regulatory Programs

Enc: Appeal Procedure

c: Secretary, Dennis Township Planning Board (via email)
Dennis Township Construction Code Official (via email)
Secretary, Cape May County Planning Board (via email)
Cape May County Health Department (via email)
Bahram Farzaneh, PE, PP (via email)



State of New Jersey
THE PINELANDS COMMISSION
PO Box 359
NEW LISBON, NJ 08064
(609) 894-7300
www.nj.gov/pinelands



MIKIE SHERRILL
Governor
DR. DALE G. CALDWELL
Lt. Governor

General Information: Info@pinelands.nj.gov
Application Specific Information: AppInfo@pinelands.nj.gov

LAURA E. MATOS
Chair
SUSAN R. GROGAN
Executive Director

PUBLIC DEVELOPMENT APPLICATION REPORT

March 17, 2026

John Cecil, Assistant Commissioner (via email)
New Jersey Department of Environmental Protection, Office of Resource Development
501 East State Street
Trenton NJ 08625-0420

Application No.: 1989-0466.016
Block 48, Lot 1
Dennis Township

This application proposes the demolition of a 612 square foot restroom building, 50 years old or older, and the construction of a 1,010 square foot restroom building located on the above referenced 170.64 acre parcel in Dennis Township.

The existing restroom building was constructed in the early 1970s. The restroom building services the Civilian Conservation Corps Campground located within Belleplain State Forest. The Belleplain State Forest is comprised of approximately 23,000 acres. The applicant indicates that the existing restroom building requires replacement to provide Americans with Disabilities Act (ADA) accessibility. The application also proposes the installation of a concrete pad over an existing gravel drive to create one concrete ADA parking stall. The proposed restroom building will be located in the same approximate location as the existing restroom building proposed for demolition.

STANDARDS

The Commission staff has reviewed the proposed development for consistency with all standards of the Pinelands Comprehensive Management Plan (CMP). The following reviews the CMP standards that are relevant to this application:

Land Use (N.J.A.C. 7:50-5.23)

The proposed development is located in a Pinelands Forest Area. The proposed development is an accessory use to the existing campground. Campgrounds are a permitted land use in a Pinelands Forest Area.

Wetlands Standards (N.J.A.C. 7:50-6.6)

There are wetlands located on the parcel. The proposed development is located greater than 300 feet from wetlands. The proposed development is consistent with the CMP wetlands protection standards.

Vegetation Management Standards (N.J.A.C. 7:50-6.23 & 6.26)

The proposed development will be located primarily in the footprint of the existing restroom building that is proposed for demolition in this application. The proposed soil disturbance is limited to that which is necessary to accommodate the proposed development.

Cultural Resource Standards (N.J.A.C. 7:50-6.151)

The Commission staff reviewed available information to determine the potential for any significant cultural resources that could be affected by the proposed demolition. Based upon the lack of potential for significant cultural resources, a cultural resource survey was not required for the proposed demolition.

PUBLIC COMMENT

The CMP defines the proposed development as “minor” development. The CMP does not require public notice for minor public development applications. The application was designated as complete on the Commission’s website on February 20, 2026. The Commission’s public comment period closed on March 13, 2026. No public comment was submitted to the Commission regarding this application.

CONDITIONS

1. Except as modified by the below conditions, the proposed development shall adhere to the plan prepared by French & Parrello Associates, dated June 25, 2025 and revised to January 26, 2026.
2. Disposal of any construction debris or excess fill may only occur at an appropriately licensed facility.
3. Any proposed revegetation shall adhere to the "Vegetation" standards of the CMP. Where appropriate, the applicant is encouraged to utilize the following Pinelands native grasses for revegetation: Switch grass, Little bluestem and Broom-sedge.
4. Prior to any development, the applicant shall obtain any other necessary permits and approvals.

CONCLUSION

As the proposed development conforms to the standards set forth in N.J.A.C. 7:50-4.57, it is recommended that the Pinelands Commission **APPROVE** the proposed development subject to the above conditions.



State of New Jersey

THE PINELANDS COMMISSION

PO Box 359

NEW LISBON, NJ 08064

(609) 894-7300

www.nj.gov/pinelands



MIKIE SHERRILL
Governor

DR. DALE G. CALDWELL
Lt. Governor

General Information: Info@pinelands.nj.gov
Application Specific Information: AppInfo@pinelands.nj.gov

LAURA E. MATOS
Chair

SUSAN R. GROGAN
Executive Director

PINELANDS COMMISSION **APPEAL PROCEDURE**

The Pinelands Comprehensive Management Plan (N.J.A.C. 7:50-4.91) provides an interested party the right to appeal any determination made by the Executive Director to the Commission in accordance with N.J.A.C. 7:50-4.91. An interested party is someone who has a specific property interest sufficient to require a hearing on constitutional or statutory grounds. Only appeal requests submitted by someone meeting the definition of an interested party will be transmitted to the New Jersey Office of Administrative Law for a hearing. Any such appeal must be made in writing to the Commission and received by the Commission's office no later than 5:00 PM on April 6, 2026 and include the following information:

1. the name and address of the person requesting the appeal;
2. the application number;
3. the date on which the determination to be appealed was made;
4. a brief statement of the basis for the appeal; and
5. a certificate of service (a notarized statement) indicating that service of the notice has been made, by certified mail, on the clerk of the county, municipal planning board and environmental commission with jurisdiction over the property which is subject of this decision.

Within 15 days following receipt of a notice of valid appeal, the Executive Director shall initiate the procedures for assignment of an Administrative Law Judge to preside at the hearing pursuant to the Administrative Procedures Act, N.J.S.A. 52:14B-1 et seq., and the procedures established by the Office of Administrative Law. The time, date and location of such hearing shall be designated by the Office of Administrative Law.



State of New Jersey

THE PINELANDS COMMISSION

PO Box 359

NEW LISBON, NJ 08064

(609) 894-7300

www.nj.gov/pinelands



MIKIE SHERRILL
Governor

DR. DALE G. CALDWELL
Lt. Governor

General Information: Info@pinelands.nj.gov
Application Specific Information: AppInfo@pinelands.nj.gov

LAURA E. MATOS
Chair
SUSAN R. GROGAN
Executive Director

March 16, 2026

James DeHart, Business Administrator (via email)
Monroe Township
125 Virginia Avenue
Williamstown NJ 08094

Re: Application # 1990-1174.012
Block 13001, Lots 28 & 29
Monroe Township

Dear Mr. DeHart:

The Commission staff has completed its review of this application for expansion of a street hockey rink within an existing Township park. Enclosed is a copy of a Public Development Application Report. On behalf of the Commission's Executive Director, I am recommending that the Pinelands Commission approve the application with conditions at its April 10, 2026 meeting.

Any interested party may appeal this recommendation in accordance with the appeal procedure attached to this document. If no appeal is received, the Pinelands Commission may either approve the recommendation of the Executive Director or refer the application to the New Jersey Office of Administrative Law for a hearing.

Prior to any development, the applicant shall obtain any other necessary permits and approvals.

Sincerely,

Charles M. Horner, P.P.

Director of Regulatory Programs

Enc: Appeal Procedure

c: Secretary, Monroe Township Planning Board (via email)
Monroe Township Construction Code Official (via email)
Secretary, Gloucester County Planning Board (via email)
Theodore Wilkinson, PE (via email)



State of New Jersey

THE PINELANDS COMMISSION

PO Box 359

NEW LISBON, NJ 08064

(609) 894-7300

www.nj.gov/pinelands



MIKIE SHERRILL
Governor

DR. DALE G. CALDWELL
Lt. Governor

General Information: Info@pinelands.nj.gov
Application Specific Information: AppInfo@pinelands.nj.gov

LAURA E. MATOS
Chair

SUSAN R. GROGAN
Executive Director

PUBLIC DEVELOPMENT APPLICATION REPORT

March 16, 2026

James DeHart, Business Administrator (via email)
Monroe Township
125 Virginia Avenue
Williamstown NJ 08094

Application No.: 1990-1174.012
Block 13001, Lots 28 & 29
Monroe Township

This application proposes expansion of a street hockey rink within an existing Township park located on the above referenced 16.21 acre parcel in Monroe Township. The existing Township park, known as Owen's Park, contains walking paths, a basketball court, baseball fields and a street hockey rink.

The existing street hockey rink is approximately 150 feet by 75 feet in size. The new rink will be approximately 180 feet by 80 feet in size. The proposed expansion will result in an increase of 2,300 square feet of impervious surface.

STANDARDS

The Commission staff has reviewed the proposed development for consistency with all standards of the Pinelands Comprehensive Management Plan (CMP). The following reviews the CMP standards that are relevant to this application:

Land Use (N.J.A.C. 7:50-5.28)

The proposed development is located in a Pinelands Regional Growth Area. The proposed development is a permitted use in a Pinelands Regional Growth Area.

Vegetation Management Standards (N.J.A.C. 7:50-6.23 & 6.26)

The proposed development will be located within an existing maintained grass area. The proposed soil disturbance is limited to that which is necessary to accommodate the proposed development.

The Landscaping and Revegetation guidelines of the CMP recommend the use of grasses that are tolerant of droughty, nutrient poor conditions. To stabilize disturbed areas, the applicant proposes to utilize a seed mixture which meets that recommendation.

PUBLIC COMMENT

The CMP defines the proposed development as “minor” development. The CMP does not require public notice for minor public development applications. The application was designated as complete on the Commission’s website on February 13, 2026. The Commission’s public comment period closed on March 13, 2026. No public comment was submitted to the Commission regarding this application.

CONDITIONS

1. Except as modified by the below conditions, the proposed development shall adhere to the plan, consisting of 11 sheets, prepared by Bryson & Yates Consulting Engineers, LLC, all sheets dated February 12, 2026.
2. Disposal of any construction debris or excess fill may only occur at an appropriately licensed facility.
3. Any proposed revegetation shall adhere to the "Vegetation" standards of the CMP. Where appropriate, the applicant is encouraged to utilize the following Pinelands native grasses for revegetation: Switch grass, Little bluestem and Broom-sedge.
4. Prior to any development, the applicant shall obtain any other necessary permits and approvals.

CONCLUSION

As the proposed development conforms to the standards set forth in N.J.A.C. 7:50-4.57, it is recommended that the Pinelands Commission **APPROVE** the proposed development subject to the above conditions.



State of New Jersey

THE PINELANDS COMMISSION

PO Box 359

NEW LISBON, NJ 08064

(609) 894-7300

www.nj.gov/pinelands



MIKIE SHERRILL
Governor

DR. DALE G. CALDWELL
Lt. Governor

General Information: Info@pinelands.nj.gov
Application Specific Information: AppInfo@pinelands.nj.gov

LAURA E. MATOS
Chair

SUSAN R. GROGAN
Executive Director

PINELANDS COMMISSION **APPEAL PROCEDURE**

The Pinelands Comprehensive Management Plan (N.J.A.C. 7:50-4.91) provides an interested party the right to appeal any determination made by the Executive Director to the Commission in accordance with N.J.A.C. 7:50-4.91. An interested party is someone who has a specific property interest sufficient to require a hearing on constitutional or statutory grounds. Only appeal requests submitted by someone meeting the definition of an interested party will be transmitted to the New Jersey Office of Administrative Law for a hearing. Any such appeal must be made in writing to the Commission and received by the Commission's office no later than 5:00 PM on April 3, 2026 and include the following information:

1. the name and address of the person requesting the appeal;
2. the application number;
3. the date on which the determination to be appealed was made;
4. a brief statement of the basis for the appeal; and
5. a certificate of service (a notarized statement) indicating that service of the notice has been made, by certified mail, on the clerk of the county, municipal planning board and environmental commission with jurisdiction over the property which is subject of this decision.

Within 15 days following receipt of a notice of valid appeal, the Executive Director shall initiate the procedures for assignment of an Administrative Law Judge to preside at the hearing pursuant to the Administrative Procedures Act, N.J.S.A. 52:14B-1 et seq., and the procedures established by the Office of Administrative Law. The time, date and location of such hearing shall be designated by the Office of Administrative Law.



State of New Jersey

THE PINELANDS COMMISSION

PO Box 359

NEW LISBON, NJ 08064

(609) 894-7300

www.nj.gov/pinelands



MIKIE SHERRILL
Governor

DR. DALE G. CALDWELL
Lt. Governor

General Information: Info@pinelands.nj.gov
Application Specific Information: AppInfo@pinelands.nj.gov

LAURA E. MATOS
Chair

SUSAN R. GROGAN
Executive Director

March 16, 2026

Jim DeHart (via email)
Monroe Township
125 Virginia Avenue
Monroe Township NJ 08094

Re: Application # 2001-0236.004
Block 13001, Lot 16
Monroe Township

Dear Mr. DeHart:

The Commission staff has completed its review of this application for construction of an amphitheater and a 148 space paved parking lot within an existing Township park. Enclosed is a copy of a Public Development Application Report. On behalf of the Commission's Executive Director, I am recommending that the Pinelands Commission approve the application with conditions at its April 10, 2026 meeting.

Any interested party may appeal this recommendation in accordance with the appeal procedure attached to this document. If no appeal is received, the Pinelands Commission may either approve the recommendation of the Executive Director or refer the application to the New Jersey Office of Administrative Law for a hearing.

Prior to any development, the applicant shall obtain any other necessary permits and approvals.

Sincerely,

Charles M. Horner, P.P.

Director of Regulatory Programs

Enc: Appeal Procedure

c: Secretary, Monroe Township Planning Board (via email)
Monroe Township Construction Code Official (via email)
Secretary, Gloucester County Planning Board (via email)
Jessica Hauber (via email)
Joseph Genova (via email)



State of New Jersey

THE PINELANDS COMMISSION

PO Box 359

NEW LISBON, NJ 08064

(609) 894-7300

www.nj.gov/pinelands



MIKIE SHERRILL
Governor

DR. DALE G. CALDWELL
Lt. Governor

General Information: Info@pinelands.nj.gov
Application Specific Information: AppInfo@pinelands.nj.gov

LAURA E. MATOS
Chair
SUSAN R. GROGAN
Executive Director

PUBLIC DEVELOPMENT APPLICATION REPORT

March 16, 2026

Jim DeHart (via email)
Monroe Township
125 Virginia Avenue
Monroe Township NJ 08094

Application No.: 2001-0236.004
Block 13001, Lot 16
Monroe Township

This application proposes the construction of an amphitheater and a 148 space paved parking lot within an existing Township park located on the above referenced 34.85 acre parcel in Monroe Township. The existing Township park, known as Owen's Park, contains a dog park.

The proposed amphitheater includes a 3,267 square foot stage and an approximately 60,600 square foot grassed seating area. The application also proposes 2,440 linear feet of sidewalk ranging from five feet to ten feet in width.

STANDARDS

The Commission staff has reviewed the proposed development for consistency with all standards of the Pinelands Comprehensive Management Plan (CMP). The following reviews the CMP standards that are relevant to this application:

Land Use (N.J.A.C. 7:50-5.28)

The proposed development is located in a Pinelands Regional Growth Area. The proposed development is a permitted use in a Pinelands Regional Growth Area.

Wetlands Standards (N.J.A.C. 7:50-6.6)

There are wetlands located on the above referenced parcel. The proposed development will be located greater than 300 feet from wetlands. Therefore, the proposed development is consistent with the CMP wetlands protection standards.

Vegetation Management Standards (N.J.A.C. 7:50-6.23 & 6.26)

The proposed development will be located within an existing maintained grassed area. The proposed soil

disturbance is limited to that which is necessary to accommodate the proposed development.

The Landscaping and Revegetation guidelines of the CMP recommend the use of grasses that are tolerant of droughty, nutrient poor conditions. To stabilize disturbed areas, the applicant proposes to utilize a seed mixture which meets that recommendation.

Stormwater Management Standards (N.J.A.C. 7:50-6.84(a)6)

The applicant has demonstrated that the proposed development is consistent with CMP stormwater management standards. To meet the stormwater management standards, the applicant will be constructing three stormwater infiltration basins.

Cultural Resource Standards (N.J.A.C. 7:50-6.151)

The Commission staff reviewed the application for evidence of cultural resources on the parcel. Based upon the lack of potential for significant cultural resources on the parcel, a cultural resource survey was not required.

PUBLIC COMMENT

The applicant has provided the requisite public notices. Notice to required land owners within 200 feet of the above referenced parcel was completed on February 2, 2026. Newspaper public notice was completed on February 6, 2026. The application was designated as complete on the Commission's website on February 27, 2026. The Commission's public comment period closed on March 13, 2026. One public comment was submitted to the Commission regarding this application.

Commenter: Joseph Genova inquired as to the location of the ingress and egress for the proposed development.

Staff Response: The Commission staff provided the commenter with a copy of the plan for the proposed development.

CONDITIONS

1. Except as modified by the below conditions, the proposed development shall adhere to the plan, consisting of 17 sheets, prepared by Remington & Vernick Engineers, all sheets dated August 22, 2025.
2. Disposal of any construction debris or excess fill may only occur at an appropriately licensed facility.
3. Any proposed revegetation shall adhere to the "Vegetation" standards of the CMP. Where appropriate, the applicant is encouraged to utilize the following Pinelands native grasses for revegetation: Switch grass, Little bluestem and Broom-sedge.
4. Prior to any development, the applicant shall obtain any other necessary permits and approvals.

CONCLUSION

As the proposed development conforms to the standards set forth in N.J.A.C. 7:50-4.57, it is recommended that the Pinelands Commission **APPROVE** the proposed development subject to the above conditions.



State of New Jersey

THE PINELANDS COMMISSION

PO Box 359

NEW LISBON, NJ 08064

(609) 894-7300

www.nj.gov/pinelands



MIKIE SHERRILL
Governor

DR. DALE G. CALDWELL
Lt. Governor

General Information: Info@pinelands.nj.gov
Application Specific Information: AppInfo@pinelands.nj.gov

LAURA E. MATOS
Chair

SUSAN R. GROGAN
Executive Director

PINELANDS COMMISSION **APPEAL PROCEDURE**

The Pinelands Comprehensive Management Plan (N.J.A.C. 7:50-4.91) provides an interested party the right to appeal any determination made by the Executive Director to the Commission in accordance with N.J.A.C. 7:50-4.91. An interested party is someone who has a specific property interest sufficient to require a hearing on constitutional or statutory grounds. Only appeal requests submitted by someone meeting the definition of an interested party will be transmitted to the New Jersey Office of Administrative Law for a hearing. Any such appeal must be made in writing to the Commission and received by the Commission's office no later than 5:00 PM on April 3, 2026 and include the following information:

1. the name and address of the person requesting the appeal;
2. the application number;
3. the date on which the determination to be appealed was made;
4. a brief statement of the basis for the appeal; and
5. a certificate of service (a notarized statement) indicating that service of the notice has been made, by certified mail, on the clerk of the county, municipal planning board and environmental commission with jurisdiction over the property which is subject of this decision.

Within 15 days following receipt of a notice of valid appeal, the Executive Director shall initiate the procedures for assignment of an Administrative Law Judge to preside at the hearing pursuant to the Administrative Procedures Act, N.J.S.A. 52:14B-1 et seq., and the procedures established by the Office of Administrative Law. The time, date and location of such hearing shall be designated by the Office of Administrative Law.



State of New Jersey

THE PINELANDS COMMISSION

PO Box 359

NEW LISBON, NJ 08064

(609) 894-7300

www.nj.gov/pinelands



MIKIE SHERRILL
Governor

DR. DALE G. CALDWELL
Lt. Governor

General Information: Info@pinelands.nj.gov
Application Specific Information: AppInfo@pinelands.nj.gov

LAURA E. MATOS
Chair
SUSAN R. GROGAN
Executive Director

March 16, 2026

Matthew von der Hayden (via email)
Stafford Township
260 East Bay Ave.
Manahawkin NJ 08050

Re: Application # 2006-0265.003
Block 44.33, Lot 24.01
Stafford Township

Dear Mr. von der Hayden:

The Commission staff has completed its review of this application for construction of a 49 space paved parking lot within an existing Township park. Enclosed is a copy of a Public Development Application Report. On behalf of the Commission's Executive Director, I am recommending that the Pinelands Commission approve the application with conditions at its April 10, 2026 meeting.

Any interested party may appeal this recommendation in accordance with the appeal procedure attached to this document. If no appeal is received, the Pinelands Commission may either approve the recommendation of the Executive Director or refer the application to the New Jersey Office of Administrative Law for a hearing.

Prior to any development, the applicant shall obtain any other necessary permits and approvals.

Sincerely,

Charles M. Horner, P.P.

Director of Regulatory Programs

Enc: Appeal Procedure

c: Secretary, Stafford Township Planning Board (via email)
Stafford Township Construction Code Official (via email)
Stafford Township Environmental Commission (via email)
Secretary, Ocean County Planning Board (via email)
Frank J. Little, Jr., PE (via email)



State of New Jersey

THE PINELANDS COMMISSION

PO Box 359

NEW LISBON, NJ 08064

(609) 894-7300

www.nj.gov/pinelands



MIKIE SHERRILL
Governor

DR. DALE G. CALDWELL
Lt. Governor

General Information: Info@pinelands.nj.gov
Application Specific Information: AppInfo@pinelands.nj.gov

LAURA E. MATOS
Chair
SUSAN R. GROGAN
Executive Director

PUBLIC DEVELOPMENT APPLICATION REPORT

March 16, 2026

Matthew von der Hayden (via email)
Stafford Township
260 East Bay Ave.
Manahawkin NJ 08050

Application No.: 2006-0265.003
Block 44.33, Lot 24.01
Stafford Township

This application proposes construction of a 49 space paved parking lot within an existing Township park on the above referenced 20.15 acre parcel. The existing Township park, known as Lighthouse Park, contains active recreational facilities including baseball fields, basketball courts and pickle ball courts.

STANDARDS

The Commission staff has reviewed the proposed development for consistency with all standards of the Pinelands Comprehensive Management Plan (CMP). The following reviews the CMP standards that are relevant to this application:

Land Use (N.J.A.C. 7:50-5.28)

The parcel is located in a Pinelands Regional Growth Area. The proposed development is a permitted land use in a Pinelands Regional Growth Area.

Vegetation Management Standards (N.J.A.C. 7:50-6.23 & 6.26)

The proposed development will be located within a maintained grass area and a wooded area. The proposed development will disturb approximately 25,000 square feet (0.57 acres) of wooded lands. The proposed clearing and soil disturbance is limited to that which is necessary to accommodate the proposed development.

The Landscaping and Revegetation guidelines of the CMP recommend the use of grasses that are tolerant of droughty, nutrient poor conditions. To stabilize disturbed areas, the applicant proposes to utilize grass species which meet that recommendation.

Stormwater Management Standards (N.J.A.C. 7:50-6.84(a)6)

The applicant has demonstrated that the proposed development is consistent with the CMP stormwater management standards. To meet the stormwater management standards, the application proposes to construct three stormwater infiltration basins.

Cultural Resource Standards (N.J.A.C. 7:50-6.151)

The Commission staff reviewed available information to determine the potential for any significant cultural resources that could be affected by the proposed development. Based on the lack of potential for significant cultural resources within the area to be developed, a cultural resource survey was not required.

PUBLIC COMMENT

The applicant has provided the requisite public notices. Newspaper public notice was completed on January 7, 2026. Notice to required land owners within 200 feet of the above referenced parcel was completed on February 20, 2026. The application was designated as complete on the Commission's website on February 20, 2026. The Commission's public comment period closed on March 13, 2026. No public comment was submitted to the Commission regarding this application.

CONDITIONS

1. Except as modified by the below conditions, the proposed development shall adhere to the plan, consisting of 12 sheets, prepared by Owen, Little & Associates Inc. and dated as follows:

Sheets 1, 5, 8 & 11 - May 7, 2025; last revised December 1, 2025
Sheets 2-4, 6, 7, 9, 10 & 12 - May 7, 2025
2. Disposal of any construction debris or excess fill may only occur at an appropriately licensed facility.
3. Any proposed revegetation shall adhere to the "Vegetation" standards of the CMP. Where appropriate, the applicant is encouraged to utilize the following Pinelands native grasses for revegetation: Switch grass, Little bluestem and Broom-sedge.
4. Prior to any development, the applicant shall obtain any other necessary permits and approvals.

CONCLUSION

As the proposed development conforms to the standards set forth in N.J.A.C. 7:50-4.57, it is recommended that the Pinelands Commission **APPROVE** the proposed development subject to the above conditions.



State of New Jersey

THE PINELANDS COMMISSION

PO Box 359

NEW LISBON, NJ 08064

(609) 894-7300

www.nj.gov/pinelands



MIKIE SHERRILL
Governor

DR. DALE G. CALDWELL
Lt. Governor

General Information: Info@pinelands.nj.gov
Application Specific Information: AppInfo@pinelands.nj.gov

LAURA E. MATOS
Chair

SUSAN R. GROGAN
Executive Director

PINELANDS COMMISSION **APPEAL PROCEDURE**

The Pinelands Comprehensive Management Plan (N.J.A.C. 7:50-4.91) provides an interested party the right to appeal any determination made by the Executive Director to the Commission in accordance with N.J.A.C. 7:50-4.91. An interested party is someone who has a specific property interest sufficient to require a hearing on constitutional or statutory grounds. Only appeal requests submitted by someone meeting the definition of an interested party will be transmitted to the New Jersey Office of Administrative Law for a hearing. Any such appeal must be made in writing to the Commission and received by the Commission's office no later than 5:00 PM on April 3, 2026 and include the following information:

1. the name and address of the person requesting the appeal;
2. the application number;
3. the date on which the determination to be appealed was made;
4. a brief statement of the basis for the appeal; and
5. a certificate of service (a notarized statement) indicating that service of the notice has been made, by certified mail, on the clerk of the county, municipal planning board and environmental commission with jurisdiction over the property which is subject of this decision.

Within 15 days following receipt of a notice of valid appeal, the Executive Director shall initiate the procedures for assignment of an Administrative Law Judge to preside at the hearing pursuant to the Administrative Procedures Act, N.J.S.A. 52:14B-1 et seq., and the procedures established by the Office of Administrative Law. The time, date and location of such hearing shall be designated by the Office of Administrative Law.



RESOLUTION OF THE NEW JERSEY PINELANDS COMMISSION

NO. PC4-26- 07

TITLE: **Approving** With Conditions an Application for **Public Development** (Application Number 1985-0202.008)

Commissioner Pikolycky moves and Commissioner Mauriello seconds the motion that:

WHEREAS, the Pinelands Commission has reviewed the Public Development Application Report and the recommendation of the Executive Director that the following application for Public Development be approved with conditions:

1985-0202.008

Applicant:	Hamilton Township Board of Education
Municipality:	Hamilton Township
Management Area:	Pinelands Regional Growth Area
Date of Report:	March 16, 2026
Proposed Development:	Construction of an 8,263 square foot school addition and a 3,217 square foot playground at the Shaner School.

WHEREAS, a 3,217 square foot playground and a 1,020 square foot expansion of an existing play area were previously developed on the parcel prior to the completion of an application with the Commission; and

WHEREAS, an irrigation well was also installed on the parcel prior to the completion of an application with the Commission; and

WHEREAS, this development constitutes a violation of the application requirements of the Pinelands Comprehensive Management Plan (CMP); and

WHEREAS, the applicant proposes to address these violations by including the 3,217 square foot playground in this application, proposing to remove the 1,020 square foot play area expansion from the parcel; and the Township Board of Education has submitted an application to the Commission for the irrigation well (App. No. 1985-0202.006); and

WHEREAS, no request for a hearing before the New Jersey Office of Administrative Law regarding the Executive Director's recommendation has been received for this application; and

WHEREAS, the Pinelands Commission hereby adopts the Conclusion of the Executive Director for the proposed development; and

WHEREAS, the Pinelands Commission hereby determines that the proposed development conforms to the standards for approving an application for public development set forth in N.J.A.C. 7:50-4.57 of the CMP if the conditions recommended by the Executive Director are imposed; and

WHEREAS, pursuant to N.J.S.A. 13A-5h, no action authorized by the Commission shall have force or effect until ten (10) days, Saturdays, Sundays and public holidays excepted, after a copy of the minutes of the meeting of the Commission has been delivered to the Governor for review, unless prior to expiration of the review period the Governor shall approve same, in which case the action shall become effective upon such approval.

NOW, THEREFORE BE IT RESOLVED that Application Number 1985-0202.008 for public development is hereby **approved** subject to the conditions recommended by the Executive Director.

Record of Commission Votes

AYE				NAY				NP				A/R*			
AYE	NAY	NP	A/R*	AYE	NAY	NP	A/R*	AYE	NAY	NP	A/R*	AYE	NAY	NP	A/R*
Asselta	X			Lohbauer	X			Rittler Sanchez	X						
Avery	X			Matro	X			Signor	X						
Buzby-Cope	X			Mauriello	X			Wallner	X						
Irick	X			Meade			X	Matos				X			
Lettman			X	Pikolycky	X										

*A = Abstained / R = Recused

Adopted at a meeting of the Pinelands Commission

Date: April 10, 2026



Susan R. Grogan
Executive Director



Alan W. Avery, Jr.
Vice Chair



State of New Jersey

THE PINELANDS COMMISSION

PO Box 359

NEW LISBON, NJ 08064

(609) 894-7300

www.nj.gov/pinelands



MIKIE SHERRILL
Governor

DR. DALE G. CALDWELL
Lt. Governor

General Information: Info@pinelands.nj.gov
Application Specific Information: AppInfo@pinelands.nj.gov

LAURA E. MATOS
Chair
SUSAN R. GROGAN
Executive Director

March 16, 2026

Christopher Veneziani (via email)
Hamilton Township Board of Education
5801 3rd Street
Mays Landing NJ 08330

Re: Application # 1985-0202.008
Block 809, Lots 17 & 18
Hamilton Township

Dear Mr. Veneziani:

The Commission staff has completed its review of this application for the construction of an 8,263 square foot school addition and a 3,217 square foot playground at the Shaner School on the above referenced 8.8 acre parcel. Enclosed is a copy of a Public Development Application Report. On behalf of the Commission's Executive Director, I am recommending that the Pinelands Commission approve the application with conditions at its April 10, 2026 meeting.

A 3,217 square foot playground and a 1,020 square foot expansion of an existing play area were previously developed on the parcel prior to the completion of an application with the Commission. This development constitutes a violation of the application requirements of the Pinelands Comprehensive Management Plan (CMP). To address these violations, this application includes the 3,217 square foot playground and proposes to remove the 1,020 square foot play area expansion.

An irrigation well was installed on the parcel prior to the completion of an application with the Commission. The installation of the irrigation well constitutes a violation of the application requirements of the CMP. The Township Board of Education has submitted an application to the Commission for the irrigation well (App. No. 1985-0202.006). By email dated January 15, 2026, the Commission staff requested information to complete the application.

Any interested party may appeal this recommendation in accordance with the appeal procedure attached to this document. If no appeal is received, the Pinelands Commission may either approve the recommendation of the Executive Director or refer the application to the New Jersey Office of Administrative Law for a hearing.

Prior to any development, the applicant shall obtain any other necessary permits and approvals.

Sincerely,

A handwritten signature in black ink, appearing to read 'C. M. Horner', with a long horizontal flourish extending to the right.

Charles M. Horner, P.P.
Director of Regulatory Programs

Enc: Appeal Procedure

c: Secretary, Hamilton Township Planning Board (via email)
Hamilton Township Construction Code Official (via email)
Atlantic County Department of Regional Planning and Development (via email)
Dave Scheidegg (via email)



State of New Jersey

THE PINELANDS COMMISSION

PO Box 359

NEW LISBON, NJ 08064

(609) 894-7300

www.nj.gov/pinelands



MIKIE SHERRILL
Governor

DR. DALE G. CALDWELL
Lt. Governor

General Information: Info@pinelands.nj.gov
Application Specific Information: AppInfo@pinelands.nj.gov

LAURA E. MATOS
Chair
SUSAN R. GROGAN
Executive Director

PUBLIC DEVELOPMENT APPLICATION REPORT

March 16, 2026

Christopher Veneziani (via email)
Hamilton Township Board of Education
5801 3rd Street
Mays Landing NJ 08330

Application No.: 1985-0202.008
Block 809, Lots 17 & 18
Hamilton Township

This application proposes the construction of an 8,263 square foot addition to the Joseph Shaner School, a 3,217 square foot playground and approximately 2,250 linear feet of sidewalk on the above referenced 8.8 acre parcel in Hamilton Township.

A 3,217 square foot playground and a 1,020 square foot expansion of an existing play area were previously developed on the parcel prior to the completion of an application with the Commission. This development constitutes a violation of the application requirements of the Pinelands Comprehensive Management Plan (CMP). To address these violations, this application includes the 3,217 square foot playground and proposes to remove the 1,020 square foot play area expansion.

An irrigation well was installed on the parcel prior to the completion of an application with the Commission. The installation of the irrigation well constitutes a violation of the application requirements of the CMP. The Township Board of Education has submitted an application to the Commission for the irrigation well (App. No. 1985-0202.006). By email dated January 15, 2026, the Commission staff requested information to complete the application.

STANDARDS

The Commission staff has reviewed the proposed development for consistency with all standards of the CMP. The following reviews the CMP standards that are relevant to this application:

Land Use (N.J.A.C. 7:50-5.28(a))

The proposed development is located within a Pinelands Regional Growth Area. The proposed development is a permitted land use in a Pinelands Regional Growth Area.

Wetlands Standards (N.J.A.C. 7:50-6.14)

There are wetlands located on and adjacent to the parcel. Existing development, including multiple playground areas, is located approximately 29 feet from wetlands. That development was constructed prior to the 1981 effective date of the Commission's regulations. The proposed school addition will be located approximately 265 feet from wetlands. The proposed 3,217 square foot playground will be located approximately 54 feet from wetlands. The proposed development will be no closer to wetlands than existing development. The proposed development is consistent with the CMP wetlands protection standards.

Vegetation Management Standards (N.J.A.C. 7:50-6.23 & 6.26)

The proposed development will be located in an existing developed and maintained grassed area. The proposed soil disturbance is limited to that which is necessary to accommodate the proposed development.

The Landscaping and Revegetation guidelines of the CMP recommend the use of grasses that are tolerant of droughty, nutrient poor conditions. The applicant proposes to utilize a seed mixture which meets that recommendation.

Water Quality Standard (N.J.A.C. 7:50-6.83)

The existing school is serviced by public sanitary sewer. The proposed building addition will be serviced by public sanitary sewer.

Stormwater Management Standards (N.J.A.C. 7:50-6.84(a)6)

The applicant has demonstrated that the proposed development is consistent with the CMP stormwater management standards. To meet the stormwater management standards, the applicant will be constructing an underground stormwater infiltration system.

Cultural Resource Standards (N.J.A.C. 7:50-6.151)

The Commission staff reviewed the application for evidence of cultural resources on the parcel. Based upon the lack of potential for significant cultural resources on the parcel, a cultural resource survey was not required.

PUBLIC COMMENT

The applicant has provided the requisite public notices. Notice to required land owners within 200 feet of the parcel was completed on November 18, 2025. Newspaper public notice was completed on November 20, 2025. The application was designated as complete on the Commission's website on February 25, 2026. The Commission's public comment period closed on March 13, 2026. No public comment was submitted to the Commission regarding this application.

CONDITIONS

1. Except as modified by the below conditions, the proposed development shall adhere to the plan, consisting of seven sheets, prepared by Schaeffer, Nassar, Scheidegg,

Consulting Engineers, LLC, dated August 27, 2025 and last revised January 6, 2026.

2. Disposal of any construction debris or excess fill may only occur at an appropriately licensed facility.
3. Any proposed revegetation shall adhere to the "Vegetation" standards of the CMP. Where appropriate, the applicant is encouraged to utilize the following Pinelands native grasses for revegetation: Switch grass, Little bluestem and Broom-sedge.
4. Prior to any development, the applicant shall obtain any other necessary permits and approvals.
5. Appropriate measures shall be taken during construction to preclude sedimentation from entering wetlands and shall be maintained in place until all development has been completed and the area has been stabilized.
6. The 1,020 square foot playground expansion that occurred on the parcel prior to the completion of an application with the Commission shall be removed and revegetated with grasses by December 31, 2026. The concerned playground expansion is identified on the above referenced plan by a note indicating "Proposed 1,020 s.f. playground area to be removed & replaced with topsoil and grass."
7. By October 1, 2026, the applicant shall either have received a Commission public development approval for the irrigation well that was installed on the parcel without completion of an application with the Commission or the irrigation well shall be decommissioned.

CONCLUSION

As the proposed development conforms to the standards set forth in N.J.A.C. 7:50-4.57, it is recommended that the Pinelands Commission **APPROVE** the proposed development subject to the above conditions.



State of New Jersey

THE PINELANDS COMMISSION

PO Box 359

NEW LISBON, NJ 08064

(609) 894-7300

www.nj.gov/pinelands



MIKIE SHERRILL
Governor

DR. DALE G. CALDWELL
Lt. Governor

General Information: Info@pinelands.nj.gov
Application Specific Information: AppInfo@pinelands.nj.gov

LAURA E. MATOS
Chair

SUSAN R. GROGAN
Executive Director

PINELANDS COMMISSION **APPEAL PROCEDURE**

The Pinelands Comprehensive Management Plan (N.J.A.C. 7:50-4.91) provides an interested party the right to appeal any determination made by the Executive Director to the Commission in accordance with N.J.A.C. 7:50-4.91. An interested party is someone who has a specific property interest sufficient to require a hearing on constitutional or statutory grounds. Only appeal requests submitted by someone meeting the definition of an interested party will be transmitted to the New Jersey Office of Administrative Law for a hearing. Any such appeal must be made in writing to the Commission and received by the Commission's office no later than 5:00 PM on April 3, 2026 and include the following information:

1. the name and address of the person requesting the appeal;
2. the application number;
3. the date on which the determination to be appealed was made;
4. a brief statement of the basis for the appeal; and
5. a certificate of service (a notarized statement) indicating that service of the notice has been made, by certified mail, on the clerk of the county, municipal planning board and environmental commission with jurisdiction over the property which is subject of this decision.

Within 15 days following receipt of a notice of valid appeal, the Executive Director shall initiate the procedures for assignment of an Administrative Law Judge to preside at the hearing pursuant to the Administrative Procedures Act, N.J.S.A. 52:14B-1 et seq., and the procedures established by the Office of Administrative Law. The time, date and location of such hearing shall be designated by the Office of Administrative Law.



RESOLUTION OF THE NEW JERSEY PINELANDS COMMISSION

NO. PC4-26-08 _____

TITLE: To Accept the Fiscal Year 2022 Audit Report

Commissioner Lohbauer **moves and Commissioner** Pikolycky
seconds the motion that:

WHEREAS, the Pinelands Protection Act (N.J.S.A. 13:18A-18) directs the New Jersey State Auditor to conduct an annual audit of the Pinelands Commission’s activities; and

WHEREAS, the New Jersey State Auditor commenced the required audit for FY2022 in March 2024; and

WHEREAS, the New Jersey State Auditor completed the audit of the Pinelands Commission’s Fiscal Year 2022 Financial Statements, Notes to the Financial Statements and Schedules of Federal and State Assistance and provided a confidential draft report to the Commission on February 3, 2026; and

WHEREAS, the Fiscal Year 2022 Audit Report contains two findings, the first dealing with internal controls over Financial Reporting and the second related to a lack of formal written policies and segregation of duties with regard to the Edmunds Accounting System; and

WHEREAS, on February 20 and 25, 2026, the Commission staff responded to the two findings by outlining the corrective actions it had taken and would be taking in the near future; and

WHEREAS, such corrective actions include retention of a new outside accounting firm to address the Financial Reporting internal controls, hiring a new business assistant to perform day-to-day bookkeeping responsibilities, segregation of duties in the Edmunds Accounting System and preparation of a formal written Risk Assessment and Security Plan for the Edmunds Accounting Software as required by the 2024 New Jersey Statewide Information Security Manual; and

WHEREAS, the State Auditor provided a copy of the final FY2022 Audit Report to the Commission on March 3, 2026; and

WHEREAS, the Commission’s Audit Committee met on March 20, 2026 to discuss the FY2022 Audit Report, the findings and proposed corrective actions; and

WHEREAS, the Commission has reviewed the FY2022 Audit Report and determined that the proposed corrective actions are appropriate; and

WHEREAS, pursuant to N.J.S.A. 13:18A-5h, no action authorized by the Commission shall have force or effect until ten (10) days, Saturdays, Sundays and public holidays excepted, after a copy of the minutes of the meeting of the Commission has been delivered to the Governor for review, unless prior to expiration of the review period the Governor shall approve same, in which case the action shall become effective upon such approval.

NOW, THEREFORE BE IT RESOLVED that:

1. The Pinelands Commission hereby directs the Executive Director to complete the corrective actions described above prior to State Auditor’s commencement of the Commission’s FY2023 Audit.

- The Pinelands Commission accepts the Audit Report for Fiscal Year 2022 and directs that it be included as a publication available through the Pinelands Commission’s website.

Record of Commission Votes

	AYE	NAY	NP	A/R*		AYE	NAY	NP	A/R*		AYE	NAY	NP	A/R*
Asselta	X				Lohbauer	X				Rittler Sanchez	X			
Avery	X				Matro	X				Signor	X			
Buzby-Cope	X				Mauriello	X				Wallner	X			
Irick	X				Meade	X				Matos			X	
Lettman			X		Pikolycky	X								

*A = Abstained / R = Recused

Adopted at a meeting of the Pinelands Commission

Date: April 10, 2026

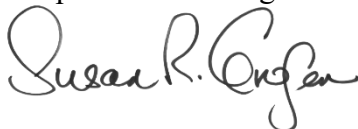

Susan R. Grogan
Executive Director

Alan W. Avery, Jr.
Vice Chair

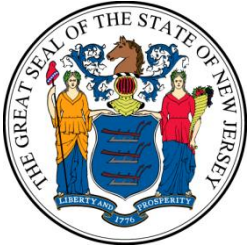

NEW JERSEY LEGISLATURE
OFFICE OF LEGISLATIVE SERVICES
OFFICE OF THE STATE AUDITOR

Pinelands Commission

Fiscal Year 2022

David J. Kaschak
State Auditor

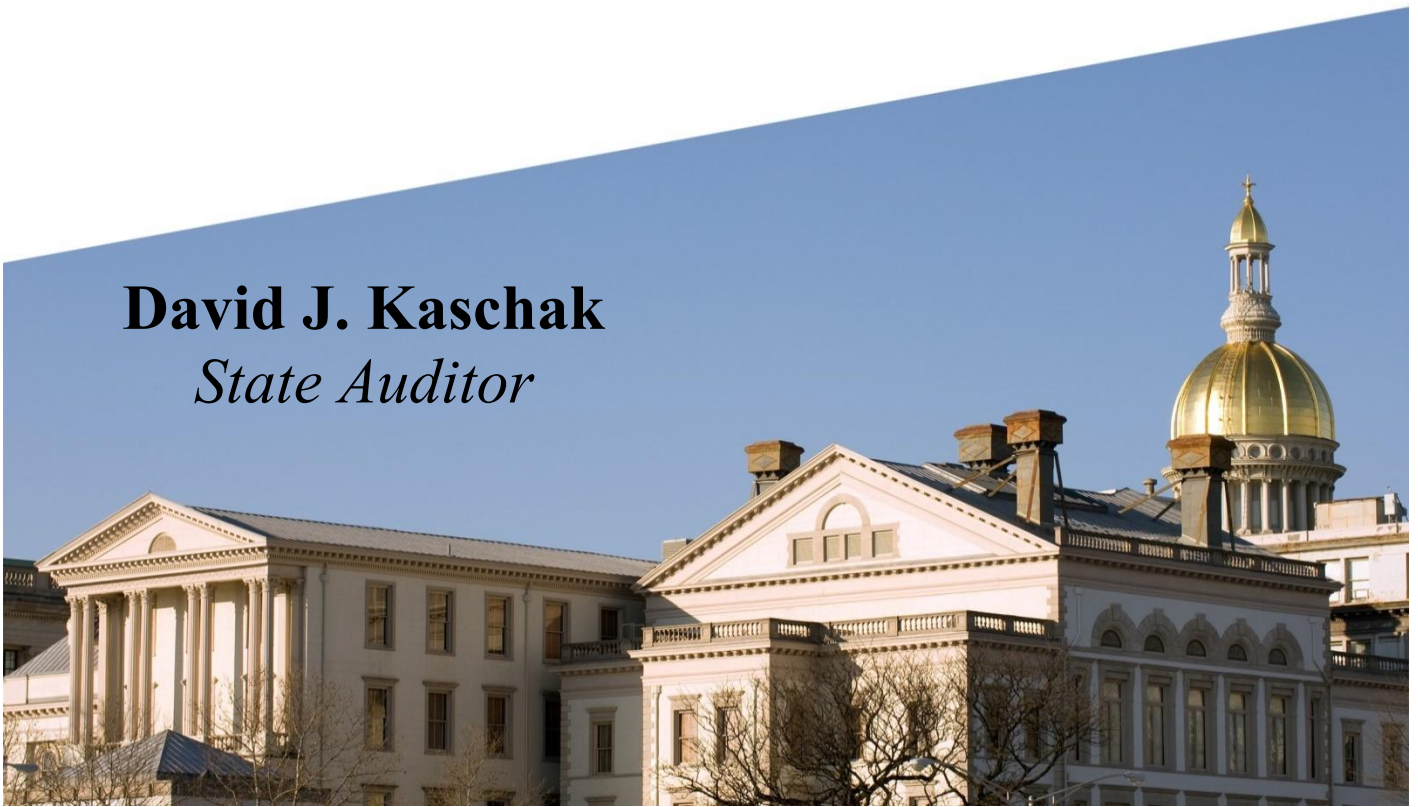

2024-2025
LEGISLATIVE SERVICES COMMISSION

SENATE

Anthony M. Bucco
Kristin M. Corrado
Linda R. Greenstein
Joseph Pennacchio
M. Teresa Ruiz
Nicholas P. Scutari
Robert W. Singer
Shirley K. Turner

GENERAL ASSEMBLY

Craig J. Coughlin
Christopher P. DePhillips
John DiMaio
Louis D. Greenwald
Antwan L. McClellan
Nancy F. Muñoz
Verlina Reynolds-Jackson
Shanique Speight



NEW JERSEY LEGISLATURE
OFFICE OF LEGISLATIVE SERVICES

125 SOUTH WARREN STREET • P.O. BOX 067 • TRENTON, NJ 08625-0067
www.njleg.gov

OFFICE OF THE STATE AUDITOR
609-847-3470

David J. Kaschak
State Auditor

Brian M. Klingele
Assistant State Auditor

Robert F. Gatti
Assistant State Auditor

The Honorable Mikie Sherrill
Governor of New Jersey

The Honorable Nicholas P. Scutari
President of the Senate

The Honorable Craig J. Coughlin
Speaker of the General Assembly

Ms. Maureen McMahan
Executive Director
Office of Legislative Services

Enclosed is our report on the audit of the Pinelands Commission for the fiscal year ended June 30, 2022. If you would like a personal briefing, please call me at (609) 847-3470.

A handwritten signature in black ink that reads "David J. Kaschak".

David J. Kaschak
State Auditor
March 3, 2026

**PINELANDS COMMISSION
TABLE OF CONTENTS**

Independent Auditor’s Report.....	1
Financial Statements	
Combined Balance Sheet – All Fund Types and Account Groups	6
Combined Statement of Revenues, Expenditures, and Changes in Fund Balances – All Governmental and Fiduciary Fund Types	7
Combined Statement of Revenues, Expenditures, and Changes in Fund Balances – General and Special Revenue Fund Types – Budget and Actual – Budgetary Basis	8
Notes to the Financial Statements.....	9
Required Supplementary Information	
Schedule of the Commission’s Proportionate Share of the Net Pension Liability, Public Employees’ Retirement System – Local	37
Schedule of the Commission’s Contributions – Public Employees’ Retirement System – Local.....	38
Schedule of Changes in the Total OPEB Liability and the Commission’s Proportionate Share of the Net OPEB Liability – State Health Benefit Retired Employees’ OPEB Plan.....	39
Schedule of the Commission’s Contributions – State Health Benefit Retired Employees’ OPEB Plan.....	40
Other Information	
Schedule of Expenditures of State Financial Assistance	42
Notes to the Schedule of Expenditures of State Financial Assistance.....	43
Report on Internal Control over Financial Reporting and on Compliance and Other Matters Based on an Audit of Financial Statements Performed in Accordance with <i>Government Auditing Standards</i>	45
Schedule of Audit Findings and Responses.....	48
Report on Compliance for Each Major State Program; Report on Internal Control over Compliance; and Report on the Schedule of Expenditures of State Financial Assistance Required by New Jersey Department of the Treasury Circular No. 15-08-OMB.....	51
Summary Schedule of Audit Findings and Questioned Costs.....	55
Summary Schedule of Prior Audit Findings and Questioned Costs.....	58
Auditee Response.....	59



SENATE

Anthony M. Bucco
Kristin M. Corrado
Linda R. Greenstein
Joseph Pennacchio
M. Teresa Ruiz
Nicholas P. Scutari
Robert W. Singer
Shirley K. Turner

David J. Kaschak
State Auditor

Brian M. Klingele
Assistant State Auditor

Robert F. Gatti
Assistant State Auditor

NEW JERSEY LEGISLATURE
OFFICE OF LEGISLATIVE SERVICES

GENERAL ASSEMBLY

Craig J. Coughlin
Christopher P. DePhillips
John DiMaio
Louis D. Greenwald
Antwan L. McClellan
Nancy F. Muñoz
Verlina Reynolds-Jackson
Shanique Speight

125 SOUTH WARREN STREET • P.O. BOX 067 • TRENTON, NJ 08625-0067
www.njleg.gov

INDEPENDENT AUDITOR'S REPORT

The Honorable Mikie Sherrill
Governor of New Jersey

The Honorable Nicholas P. Scutari
President of the Senate

The Honorable Craig J. Coughlin
Speaker of the General Assembly

Ms. Maureen McMahon
Executive Director
Office of Legislative Services

Report on the Audit of the Financial Statements

Opinions

We have audited the modified accrual basis financial statements of the Pinelands Commission as of and for the year ended June 30, 2022, and the related notes to the financial statements, which collectively comprise the Pinelands Commission's basic financial statements as listed in the table of contents.

In our opinion, the financial statements referred to above present fairly, in all material respects, the respective modified accrual basis financial position of the governmental activities and each major fund of the Pinelands Commission as of June 30, 2022, and the respective changes in financial position, and budgetary comparisons for the General Fund and the Special Revenue Funds for the year then ended in accordance with the modified accrual basis of accounting described in Note 1.

Basis for Opinions

We conducted our audit in accordance with auditing standards generally accepted in the United States of America (GAAS) and the standards applicable to financial audits contained in *Government Auditing Standards*, issued by the Comptroller General of the United States. Our responsibilities under those standards are further described in the Auditor's Responsibilities for the Audit of Financial Statements section of our report. We are required to be independent of the Pinelands Commission, and to meet our other ethical responsibilities, in accordance with the relevant ethical requirements relating to our audit. We believe that the audit evidence we have obtained is sufficient and appropriate to provide a basis for our audit opinions.

Emphasis of Matters

Basis of Accounting

We draw attention to Note 1 of the financial statements, which describes the basis of accounting. The financial statements are prepared on the modified accrual basis of accounting, which is a basis of accounting other than accounting principles generally accepted in the United States of America. Our opinion was not modified with respect to this matter.

Adoption of New Accounting Pronouncements

As discussed in Note 1, the Commission adopted the provisions of Governmental Accounting Standards Board (GASB) Statement No. 87, *Leases*, GASB Statement No. 89, *Accounting for Interest Cost Incurred before the End of a Construction Period*, GASB Statement No. 91 *Conduit Debt Obligations*, GASB Statement No. 92 *Omnibus 2020*, GASB Statement No. 93 *Replacement of Interbank Offered Rates*, GASB Statement No. 97, *Certain Component Unit Criteria*, and *Accounting and Financial Reporting for Internal Revenue Code Section 457 Deferred Compensation Plans*. Our opinion was not modified with respect to these matters.

Responsibilities of Management for the Financial Statements

Management is responsible for the preparation and fair presentation of the financial statements in accordance with the modified accrual basis of accounting described in Note 1; this includes determining that the modified accrual basis of accounting is an acceptable basis for the preparation of the financial statements in the circumstances. Management is also responsible for the design, implementation, and maintenance of internal control relevant to the preparation and fair presentation of financial statements that are free from material misstatements, whether due to fraud or error.

In preparing the financial statements, management is required to evaluate whether there are conditions or events, considered in the aggregate, that raise substantial doubt about the Pinelands Commission's ability to continue as a going concern for twelve months beyond the financial statement date, including any currently known information that may raise substantial doubt shortly thereafter.

Auditor's Responsibilities for the Audit of the Financial Statements

Our objectives are to obtain reasonable assurance about whether the financial statements as a whole are free from material misstatement, whether due to fraud or error, and to issue an auditor's report that includes our opinions. Reasonable assurance is a high level of assurance but is not absolute assurance and therefore is not a guarantee that an audit conducted in accordance with GAAS and *Government Auditing Standards* will always detect a material misstatement when it exists. The risk of not detecting a material misstatement resulting from fraud is higher than for one resulting from error, as fraud may involve collusion, forgery, intentional omissions, misrepresentations, or the override of internal control. Misstatements are considered material if there is a substantial likelihood that, individually or in the aggregate, they would influence the judgement made by a reasonable user based on the financial statements.

In performing an audit in accordance with GAAS and *Government Auditing Standards*, we:

- exercise professional judgment and maintain professional skepticism throughout the audit.
- identify and assess the risks of material misstatement of the financial statements, whether due to fraud or error, and design and perform audit procedures responsive to those risks. Such procedures include examining, on a test basis, evidence regarding the amounts and disclosures in the financial statements.
- obtain an understanding of internal control relevant to the audit in order to design audit procedures that are appropriate in the circumstances, but not for the purpose of expressing an opinion on the effectiveness of the Pinelands Commission's internal control. Accordingly, no such opinion is expressed.
- evaluate the appropriateness of accounting policies used and the reasonableness of significant accounting estimates made by management, as well as evaluate the overall presentation of the financial statements.
- conclude whether, in our judgment, there are conditions or events, considered in the aggregate, that raise substantial doubt about the Pinelands Commission's ability to continue as a going concern for a reasonable period of time.

We are required to communicate with those charged with governance regarding, among other matters, the planned scope and timing of the audit, significant audit findings, and certain internal control-related matters that we identified during the audit.

Required Supplementary Information

Accounting principles generally accepted in the United States of America require that the management's discussion and analysis and the schedules listed under Required Supplementary Information in the accompanying table of contents be presented to supplement the basic financial statements. Such information is the responsibility of management and, although not a part of the basic financial statements, is required by the Governmental Accounting Standards Board who

considers it to be an essential part of financial reporting for placing the basic financial statements in an appropriate operational, economic, or historical context. We have applied certain limited procedures to the required supplementary information in accordance with GAAS, which consisted of inquiries of management about the methods of preparing the information and comparing the information for consistency with management's responses to our inquiries, the basic financial statements, and other knowledge we obtained during our audit of the basic financial statements. We do not express an opinion or provide any assurance on the information because the limited procedures do not provide us with sufficient evidence to express an opinion or provide any assurance.

Management has omitted the management's discussion and analysis that accounting principles generally accepted in the United States of America require to be presented to supplement the basic financial statements. Such missing information, although not a part of the basic financial statements, is required by the Governmental Accounting Standards Board, which considers it to be an essential part of financial reporting for placing the basic financial statements in an appropriate operational, economic, or historical context. Our opinion on the basic financial statements is not affected by this missing information.

Other Information

Management is responsible for the other information included in the annual report. The other information is comprised of the Schedule of Expenditures of State Financial Assistance and the related notes but does not include the basic financial statements and our auditor's report thereon.

Our audit was conducted for the purpose of forming an opinion on the Pinelands Commission's financial statements. The Schedule of Expenditures of State Financial Assistance is presented for the purpose of additional analysis as required by New Jersey Department of the Treasury Circular No. 15-08-OMB and is not a required part of the financial statements. Such information is the responsibility of management and was derived from and relates directly to the underlying accounting and other records used to prepare the basic financial statements. The information has been subjected to the auditing procedures applied in the audit of the basic financial statements and certain additional procedures, including comparing and reconciling such information directly to the underlying accounting and other records used to prepare the basic financial statements or to the basic financial statements themselves, and other additional procedures in accordance with GAAS. In our opinion, the Schedule of Expenditures of State Financial Assistance is fairly stated, in all material respects, in relation to the basic financial statements as a whole.

Other Reporting Required by Government Auditing Standards

In accordance with *Government Auditing Standards*, we have also issued our report dated March 3, 2026 on our consideration of the Pinelands Commission management's internal control over financial reporting and on our tests of its compliance with certain provisions of laws, regulations, contracts, grant agreements, and other matters. The purpose of that report is to describe the scope of our testing of internal control over financial reporting and compliance and the results of that testing, and not to provide an opinion on the effectiveness of the Pinelands Commission's internal control over financial reporting or on compliance. That report is an integral part of an audit

performed in accordance with *Government Auditing Standards* in considering the Pinelands Commission's internal control over financial reporting and compliance.



David J. Kaschak
State Auditor
March 3, 2026

PINELANDS COMMISSION
COMBINED BALANCE SHEET
ALL FUND TYPES AND ACCOUNT GROUPS
JUNE 30, 2022

	GOVERNMENTAL FUND TYPES		FIDUCIARY FUND TYPES	ACCOUNT GROUPS		TOTAL (Memorandum Only)
	GENERAL FUND	SPECIAL REVENUE FUNDS	PRIVATE PURPOSE TRUST FUNDS	GENERAL FIXED ASSETS	GENERAL LONG-TERM DEBT	
ASSETS						
Cash & Cash Equivalents	\$ 3,319,765	\$ 8,469,655	\$ -	\$ -	\$ -	\$ 11,789,420
Receivables:						
Federal	177,613	-	-	-	-	177,613
General Fixed Assets:						
Furniture & Equipment	-	-	-	1,107,675	-	1,107,675
Vehicles	-	-	-	90,371	-	90,371
Amount to be Provided for	-	-	-	-	-	-
Retirement of Long-Term Liabilities	-	-	-	-	611,443	611,443
Due from Other Funds	960,871	21,918	-	-	-	982,789
Restricted Cash & Cash Equivalents	29,760	-	49,037	-	-	78,797
Total Assets	\$ 4,488,009	\$ 8,491,573	\$ 49,037	\$ 1,198,046	\$ 611,443	\$ 14,838,108
LIABILITIES & FUND EQUITY						
Liabilities:						
Accounts Payable	\$ 976,082	\$ 10,200	\$ 1,594	\$ -	\$ -	\$ 987,876
Salaries Payable	123,344	-	-	-	-	123,344
Payroll Deductions Payable	154,337	-	-	-	-	154,337
Compensated Absences	46,368	-	-	-	611,443	657,811
Deferred Revenue	29,600	1,759,200	-	-	-	1,788,800
Due to State of New Jersey	255	-	-	-	-	255
Due to Other Funds	-	950,846	31,943	-	-	982,789
Total Liabilities	\$ 1,329,986	\$ 2,720,246	\$ 33,537	\$ -	\$ 611,443	\$ 4,695,212
Fund Equity:						
Restricted For:						
Unemployment Compensation	\$ -	\$ -	\$ 3,655	\$ -	\$ -	\$ 3,655
Katie Fund	-	-	(3,155)	-	-	(3,155)
Timber Rattlesnake Study	6,690	-	-	-	-	6,690
Rattlesnake Fencing	21,796	-	-	-	-	21,796
Committed To:						
Pinelands Conservation	-	4,808,281	-	-	-	4,808,281
Kirkwood Cohansey Study	-	62,691	-	-	-	62,691
Encumbrances	143,389	2,500	-	-	-	145,889
Retiree's Health Benefits	799,155	-	-	-	-	799,155
Microfilming Project	-	-	-	-	-	-
Building Improvements	-	-	-	-	-	-
Vehicle Replacements	-	-	-	-	-	-
Computer Replacements	-	-	-	-	-	-
Other	-	-	-	-	-	-
Investment in General Fixed Assets	-	-	-	1,198,046	-	1,198,046
Assigned To:						
Subsequent Years Expenditures	688,078	814,397	15,000	-	-	1,517,475
Other	-	83,458	-	-	-	83,458
Unassigned Fund Balance:	1,498,915	-	-	-	-	1,498,915
Total Fund Equity	\$ 3,158,023	\$ 5,771,327	\$ 15,500	\$ 1,198,046	\$ -	\$ 10,142,896
Total Liabilities & Fund Equity	\$ 4,488,009	\$ 8,491,573	\$ 49,037	\$ 1,198,046	\$ 611,443	\$ 14,838,108

The accompanying Notes to the Financial Statements are an integral part of this Statement.

PINELANDS COMMISSION
COMBINED STATEMENT OF REVENUES, EXPENDITURES AND CHANGES IN FUND BALANCES
ALL GOVERNMENTAL AND FIDUCIARY FUND TYPES
FOR THE FISCAL YEAR ENDED JUNE 30, 2022

	GOVERNMENTAL FUND TYPES		FIDUCIARY FUND TYPES	TOTAL (Memorandum Only)
	GENERAL FUND	SPECIAL REVENUE FUNDS	PRIVATE PURPOSE TRUST FUNDS	
REVENUES				
State of New Jersey Appropriations	\$ 3,249,000	\$ -	\$ -	\$ 3,249,000
Fringe Benefits Paid by the State	687,000	-	-	687,000
State of New Jersey Supplemental Appropriations	-	-	-	-
Federal Grants	412,081	-	-	412,081
State Grants	-	500,000	-	500,000
Other Grants	-	-	-	-
Interest Income	25,928	17,594	95	43,617
Unemployment Deductions	-	-	-	-
Application Fees	1,113,182	-	-	1,113,182
Other	6,930	-	80	7,010
Total Revenues	<u>\$ 5,494,121</u>	<u>\$ 517,594</u>	<u>\$ 175</u>	<u>\$ 6,011,890</u>
EXPENDITURES				
Current:				
Personnel	\$ 4,358,982	\$ 620,243	\$ -	\$ 4,979,225
Supplies	112,737	11,489	11,638	135,864
Services	595,031	113,682	-	708,713
Maintenance & Rent	54,873	-	-	54,873
Capital Outlay	52,420	-	-	52,420
State Aid & Grants	-	-	-	-
Land Acquisition	-	-	-	-
Total Expenditures	<u>\$ 5,174,043</u>	<u>\$ 745,414</u>	<u>\$ 11,638</u>	<u>\$ 5,931,095</u>
Excess/(Deficiency) of Revenues Over Expenditures	<u>\$ 320,078</u>	<u>\$ (227,820)</u>	<u>\$ (11,463)</u>	<u>\$ 80,795</u>
OTHER FINANCING SOURCES (USES)				
Uncollectible Receivables	\$ -	\$ -	\$ -	\$ -
Operating Transfers Out	-	(60,000)	-	(60,000)
Operating Transfer In	60,000	-	-	60,000
Total Other Financing Sources (Uses)	<u>\$ 60,000</u>	<u>\$ (60,000)</u>	<u>\$ -</u>	<u>\$ -</u>
Excess/(Deficiency) of Revenues Over Expenditures & Other Financing Sources (Uses)	<u>\$ 380,078</u>	<u>\$ (287,820)</u>	<u>\$ (11,463)</u>	<u>\$ 80,795</u>
Fund Balance - Beginning of the Year	<u>2,777,945</u>	<u>6,025,642</u>	<u>26,963</u>	<u>8,830,550</u>
Fund Balance - End of the Year	<u>\$ 3,158,023</u>	<u>\$ 5,737,822</u>	<u>\$ 15,500</u>	<u>\$ 8,911,345</u>

The accompanying Notes to the Financial Statements are an integral part of this Statement.

PINELANDS COMMISSION
 COMBINED STATEMENT OF REVENUES, EXPENDITURES AND CHANGES IN FUND BALANCES
 GENERAL AND SPECIAL REVENUE FUND TYPES
 BUDGET AND ACTUAL - BUDGETARY BASIS
 FOR THE FISCAL YEAR ENDED JUNE 30, 2022

	GENERAL FUND			VARIANCE FAVORABLE/ (UNFAVORABLE)	SPECIAL REVENUE FUNDS			VARIANCE FAVORABLE/ (UNFAVORABLE)
	ADOPTED BUDGET	FINAL BUDGET	ACTUAL		ADOPTED BUDGET	FINAL BUDGET	ACTUAL	
REVENUES								
State of New Jersey Appropriations	\$ 3,249,000	\$ 3,249,000	\$ 3,249,000	\$ -	\$ -	\$ -	\$ -	\$ -
State Supplemental Appropriations	-	-	-	-	-	-	-	-
Fringe Benefits Paid by the State	687,000	687,000	687,000	-	-	-	-	-
Federal Grants	618,000	618,000	412,081	(205,919)	-	-	-	-
State Grants	-	-	-	-	500,000	500,000	500,000	-
Other Grants	-	-	-	-	-	-	-	-
Interest Income	4,000	4,000	25,928	21,928	4,850	4,850	17,594	12,744
Application Fees	500,000	500,000	1,112,120	612,120	-	-	-	-
Anticipated from Reserves	142,070	142,070	-	(142,070)	-	-	-	-
Fund Balance Anticipated	705,132	705,132	705,132	-	-	-	-	-
Pinelands Conservation Activities Reserve	-	-	-	-	538,782	538,782	-	(538,782)
Other	1,000	1,000	6,930	5,930	-	-	-	-
Total Revenues	<u>\$ 5,906,202</u>	<u>\$ 5,906,202</u>	<u>\$ 6,198,191</u>	<u>\$ 291,989</u>	<u>\$ 1,043,632</u>	<u>\$ 1,043,632</u>	<u>\$ 517,594</u>	<u>\$ (526,038)</u>
EXPENDITURES								
Current:								
Personnel	\$ 4,932,889	\$ 4,932,889	\$ 4,358,982	\$ 573,907	\$ 856,512	\$ 856,512	\$ 620,243	\$ 236,269
Supplies	131,712	131,712	114,523	17,189	17,200	17,200	11,489	5,711
Services	722,351	722,351	540,639	181,712	105,620	105,620	116,182	(10,562)
Maintenance & Rent	132,620	132,620	54,873	77,747	-	-	-	-
Capital Outlay	46,630	46,630	44,177	2,453	4,300	4,300	-	4,300
State Aid and Grants	-	-	-	-	-	-	-	-
Land Acquisition	-	-	-	-	-	-	-	-
Total Expenditures	<u>\$ 5,966,202</u>	<u>\$ 5,966,202</u>	<u>\$ 5,113,194</u>	<u>\$ 853,008</u>	<u>\$ 983,632</u>	<u>\$ 983,632</u>	<u>\$ 747,914</u>	<u>\$ 235,718</u>
OTHER FINANCING SOURCES (USES)								
Uncollectible Receivables	\$ -	\$ -	\$ -	\$ -	\$ -	\$ -	\$ -	\$ -
Operating Transfers Out	-	-	-	-	(60,000)	(60,000)	(60,000)	-
Operating Transfer In	60,000	60,000	60,000	-	-	-	-	-
Total Other Financing Sources (Uses)	<u>\$ 60,000</u>	<u>\$ 60,000</u>	<u>\$ 60,000</u>	<u>\$ -</u>	<u>\$ (60,000)</u>	<u>\$ (60,000)</u>	<u>\$ (60,000)</u>	<u>\$ -</u>
Net Increase/(Decrease) in Fund Balances	<u>\$ -</u>	<u>\$ -</u>	<u>\$ 1,144,997</u>	<u>\$ 1,144,997</u>	<u>\$ -</u>	<u>\$ -</u>	<u>\$ (290,320)</u>	<u>\$ (290,320)</u>

The accompanying Notes to the Financial Statements are an integral part of this Statement.

**PINELANDS COMMISSION
NOTES TO THE FINANCIAL STATEMENTS
FOR THE FISCAL YEAR ENDED JUNE 30, 2022**

Note 1: SUMMARY OF SIGNIFICANT ACCOUNTING POLICIES

Description of the Reporting Entity – The Pinelands Commission (Commission) was formed in 1979 by the Pinelands Protection Act. The Commission is charged with the development and implementation of the Comprehensive Management Plan for the Pinelands. It plays significant roles in monitoring the level and types of development that occur within the Pinelands including, but not limited to, acquisition of land, planning, zoning, permitting, research, and education. The Commission consists of 15 members. Seven are appointed by the Governor of New Jersey. Another seven are appointed by each of the counties within the Pinelands, i.e. Atlantic, Burlington, Camden, Cape May, Cumberland, Gloucester, and Ocean. One member is appointed by the U.S. Secretary of the Interior. The Commission works closely with all levels of government, organizations, and interested citizens to help them understand and implement the Pinelands Comprehensive Management Plan.

The primary criterion for including activities within the Commission's reporting entity, as set forth in Section 2100 of the GASB Codification of Governmental Accounting and Financial Reporting Standards, is the degree of oversight responsibility maintained by the Commission. Oversight responsibility includes financial interdependency, selection of governing authority, designation of management, ability to significantly influence operations, and accountability for fiscal matters. The combined financial statements include all funds and account groups of the Commission over which the board exercises operating control. There were no additional entities required to be included in the reporting entity under the criteria as described above, in the current fiscal year.

Basis of Presentation – The financial statements are prepared on the modified accrual basis of accounting, which is a basis of accounting other than accounting principles generally accepted in the United States of America. The more significant of the Commission's accounting policies are described in this note.

The accounts of the Commission are organized on the basis of funds and account groups, each of which is considered a separate accounting entity. The operations of each fund are accounted for with a separate set of self-balancing accounts that comprise its assets, liabilities, fund equity, revenues, and expenditures or expenses, as appropriate. Government resources are allocated to and accounted for in individual funds based upon the purposes for which they are to be spent and the means by which spending activities are controlled. An account group, on the other hand, is a financial reporting device designed to provide accountability for certain assets and liabilities that are not recorded in the funds because they do

not directly affect net expendable available financial resources.

The various funds and accounts are grouped into three fund types within two broad fund categories and two account groups as follows:

GOVERNMENTAL FUNDS

General Fund – The General Fund is the general operating fund of the Commission. It is used to account for all financial resources except those required to be accounted for in another fund.

Special Revenue Funds – The Special Revenue Funds are used to account for the proceeds of specific revenues, other than trusts, that are legally restricted to expenditures for specified purposes. The Commission utilizes the following three special revenue funds:

Pinelands Development Credit Fund – This fund is used to account for appropriations from the State of New Jersey that are restricted for purchasing Pinelands Development Credits through the Pinelands Development Credit Bank.

Kirkwood-Cohansey Study Fund – This fund is used to account for monies transferred to the Commission from the “Water Supply Fund” by the State of New Jersey to fund the completion of a report on the assessment on how the future and current water supply needs within the Pinelands area may be met while protecting the Kirkwood-Cohansey aquifer system.

Pinelands Conservation Fund – The Commission has reserved a portion of this fund to be used for preservation of land and designated other portions to be used for conservation planning/research and for community planning/design.

FIDUCIARY FUNDS

Private Purpose Trust Funds – The Private Purpose Trust Funds are used to account for assets held by the Commission in a trustee capacity or as an agent on behalf of others. These include two Private Purpose Trust Funds, the Unemployment Compensation Insurance Fund, and the “Katie” Fund. Private Purpose Trust Funds are accounted for in essentially the same manner as governmental funds. Private Purpose Trust Funds account for assets of which both the principal and interest may be spent.

ACCOUNT GROUPS

General Fixed Assets Account Group – Fixed assets used in governmental fund type operations are accounted for in the General Fixed Assets Account Group, rather than in governmental funds.

General Long-Term Debt Account Group – Long-term liabilities expected to be financed from governmental funds are accounted for in the General Long-Term Debt Account Group, not in the governmental funds. This includes the non-current portion of the liability for compensated absences.

Because of their spending measurement focus, expenditure recognition for governmental fund types is limited to exclude amounts represented by non-current liabilities. Since they do not affect net current assets, such long-term amounts are not recognized as governmental fund type expenditures or fund liabilities. They are instead reported as liabilities in the General Long-Term Debt Account Group.

Basis of Accounting and Measurement Focus – The modified accrual basis of accounting is used for measuring financial position and operating results of all governmental and fiduciary fund types. Under the modified accrual basis of accounting, revenues are recognized when they become both measurable and available. Measurable means the amount of the transaction can be determined and available means collectible within the current period or soon enough thereafter to be used to pay liabilities of the current period. Expenditures are recognized in the accounting period in which the fund liability is incurred, except for principal and interest on general long-term debt, which are recorded when due.

Budgets/Budgetary Control – An annual appropriated budget is approved by the Commission each year for the General Fund and Special Revenue Funds. The budgets are prepared using the budgetary basis of accounting. Formal budgetary integration into the accounting system is employed as a management control device during the year. Encumbrance accounting is also employed as an extension of formal budgetary integration in the governmental fund types.

The accounting records of the General Fund and Special Revenue Funds are maintained on the budgetary basis. The budgetary basis differs from modified accrual basis in that the budgetary basis recognizes encumbrances as expenditures and also recognizes increases/decreases in internal designations of fund balance, whereas the modified accrual basis does not. Sufficient supplemental records are maintained to allow for the presentation of modified basis financial reports.

The budget, as detailed on the Combined Statement of Revenues, Expenditures, and Changes in Fund Balances – General and Special Revenue Fund Types – Budget and Actual – Budgetary Basis, include all amendments to the adopted budget.

The following presents a reconciliation of the General Fund from the budgetary basis of accounting as presented in the Combined Statement of Revenues, Expenditures, and Changes in Fund Balances – General and Special Revenue Fund Types – Budget and Actual – Budgetary Basis to the modified accrual basis of accounting as presented in the Combined Statement of Revenues, Expenditures, and Changes in Fund Balances – All Governmental and Fiduciary Fund Types.

Net increase (decrease) in fund balances for the year (budgetary basis)	
adjustments:	\$ 1,144,997
Less: net decrease in revenue recognized in previous years	(705,132)
Less: prior year encumbrances recognized as current year expenditures	(203,176)
Add: current year encumbrances	<u>143,389</u>
Excess (deficiency) of revenues and other financing sources over	
expenditures and other financing uses (modified accrual basis)	<u>\$ 380,078</u>

The following presents a reconciliation of the Special Revenue Funds from the budgetary basis of accounting as presented in the Combined Statement of Revenues, Expenditures, and Changes in Fund Balances – General and Special Revenue Fund Types – Budget and Actual – Budgetary Basis to the modified accrual basis of accounting as presented in the Combined Statement of Revenues, Expenditures, and Changes in Fund Balances – All Governmental and Fiduciary Fund Types.

Net decrease in fund balances for the year (budgetary basis)	
adjustments:	\$ (290,320)
Less: net decreases in revenue recognized in previous years	-
Add: prior year encumbrances recognized as current year expenditures	-
Add: current year encumbrances	<u>2,500</u>
Excess (deficiency) of revenues and other financing sources	
over expenditures and other financing uses (modified accrual basis)	<u>\$ 287,820</u>

Encumbrances – Under encumbrance accounting, purchase orders, contracts and other commitments for the expenditure of resources are recorded to reserve a portion of the applicable appropriation. Open encumbrances are reported as reservations of fund balances at fiscal year-end as they do not constitute expenditures or liabilities but rather commitments related to unperformed contracts for goods and services.

Cash and Cash Equivalents – Cash and cash equivalents include petty cash, change funds, cash in banks, and all highly liquid investments with a maturity of three months or less at the time of purchase and are stated at cost which approximates fair value. The Commission also participates in the State of New Jersey Cash Management Fund administered by the New Jersey Department of the Treasury, Division of Investment, wherein amounts contributed by the state as well as other local government units are combined into a large-scale investment program.

Fixed Assets – General fixed assets are reflected as expenditures in the applicable governmental funds, and the related assets are reported in the General Fixed Assets Account Group. Fixed assets are defined by the Commission as assets which have a cost in excess of \$250 at the date of acquisition and a useful life of one year or more.

Compensated Absences – Compensated absences are those absences for which employees will be paid, such as vacation, sick, administration, and paid leave bank. A liability for compensated absences attributable to services already rendered, and not contingent on a specific event that is outside the control of the Commission and its employees, is accrued as the employees earn the rights to the benefits. Compensated absences that relate to future services, or that are contingent on a specific event that is outside the control of the Commission and its employees, are accounted for in the period in which such services are rendered or in which such events take place.

In governmental funds, compensated absences that are expected to be liquidated with expendable available financial resources are reported as expenditure and fund liability in the fund that will pay for the compensated absences. The remainder of the compensated absences liability is reported in the General Long-Term Debt Account Group.

Due from/to Other Funds – Amounts due from/to other funds represent monies owed from or to other funds. The General Fund disburses all the funds for expenditures incurred by all other funds, and the monies are transferred between funds.

Deferred Revenue – Deferred revenue in the General and Special Revenue funds represents cash that has been received but not yet earned.

Fund Balance – Refer to Note 11 for full description.

Total Columns on Combined Statements – Total columns are captioned "Memorandum Only" to indicate that they are presented only to facilitate financial analysis. Data in these columns do not present financial position, results of operations, or changes in financial position in conformity with accounting principles generally accepted in the United States of America, nor is such data comparable to a consolidation.

Management Estimates – The preparation of financial statements in conformity with accounting principles generally accepted in the United States required management to make estimates and assumptions that affect the reported amounts of revenue and expenditures/expenses during the reporting period. Actual results can differ from those estimates.

CHANGES IN ACCOUNTING POLICY

Recently Issued Accounting Principles

In Fiscal Year 2022, the Commission adopted six new Governmental Accounting Standards Board (GASB) standards as follows:

GASB Statement No. 87, *Leases* was issued to establish standards of accounting and financial reporting for leases by lessees and lessors.

GASB Statement No. 89, *Accounting for Interest Cost Incurred before the End of a Construction Period* requires that interest cost incurred before the end of a construction period be recognized as an expense in the period in which the cost is incurred for financial statements prepared using the economic resources measurement focus. The requirements of this Statement will improve financial reporting by providing users of financial statements with more relevant information about capital assets and the cost of borrowing for a reporting period. The resulting information also will enhance the comparability of information about capital assets and the cost of borrowing for a reporting period for both governmental activities and business-type activities.

GASB Statement No. 91, *Conduit Debt Obligations* will improve financial reporting by providing a single method of reporting conduit debt obligations for government issuers and eliminate diversity in practice. The Statement achieves these objectives by clarifying the existing definition of a conduit debt obligation; establishing that a conduit debt obligation is not a liability of the issuer; establishing standards for accounting and financial reporting of additional commitments and voluntary commitments extended by issuers and arrangements associated with conduit debt obligations; and improving required note disclosures.

GASB Statement No. 92, *Omnibus 2020* was issued in January 2020 to improve the consistency in authoritative literature by addressing practice issues that have been identified during implementation and application of certain GASB Statements. Paragraphs 4, 5, 11, and 13 of this Statement were effective upon issuance, through paragraphs 4 and 5 were later delayed by GASB Statement No. 95.

GASB Statement No. 93 *Replacement of Interbank Offered Rates* applies to governments who enter into agreements that were subject to the Interbank Offered Rate (IBOR).

GASB Statement No. 97, *Certain Component Unit Criteria, and Accounting and Financial Reporting for Internal Revenue Code Section 457 Deferred Compensation Plans* was issued to increase consistency and comparability related to the reporting of fiduciary component units, mitigate costs associated with the reporting of certain defined contribution benefit plans and enhance the relevance, consistency and comparability of the accounting and financial reporting for Internal Revenue Code (IRC) Section 457 deferred compensation plans.

Accounting standards not yet adopted that the Commission is currently reviewing for applicability and potential impact include:

GASB Statement No. 94, *Public-Private and Public-Public Partnerships (PPPs) and Availability Payment Arrangements (APAs)* was issued as guidance stating that a PPP

is an arrangement in which a government contracts with an operator to provide public services by conveying control of the right to operate of use a nonfinancial asset, such as infrastructure or other capital asset, for a period of time in an exchange or exchange-like transaction. The Statement also provides guidance for APAs, which are arrangements in which a government compensates an operator for services that may include designing, construction, financing, maintaining, or operating an underlying nonfinancial asset for a period of time in an exchange or exchange-like transaction. This standard will be effective for fiscal years beginning after June 15, 2022.

GASB No.96, *Subscription-Based Information Technology Arrangements* provides guidance on the accounting and financial reporting for subscription-based information technology arrangements (SBITAs) for government end users. This statement (1) defines a SBITA; (2) establishes that a SBITA results in a right-to-use subscription asset and a corresponding liability; (3) provides the capitalization criteria for outlays other than subscription payments; and (4) requires note disclosures regarding a SBITA. This standard will be effective for fiscal years beginning after June 15, 2022.

Management has not yet determined the impact of these Statements on the financial statements.

Note 2: CASH AND CASH EQUIVALENTS

The Pinelands Commission is governed by the deposit limitations of New Jersey state law. The deposits held at June 30, 2022, and reported at fair value are as follows:

Deposits:	Amount
Demand deposits	\$ 11,867,588
Cash on hand	629
Total Deposits	<u><u>\$ 11,868,217</u></u>

Reconciliation of Statement Comparative Balance Sheets:	
General Fund	\$ 3,349,525
Special Revenue Funds	8,469,655
Private Purpose Trust Funds	49,037
Total Reconciliation of Comparative Balance Sheets	<u><u>\$ 11,868,217</u></u>

GASB Statement No. 40, *Deposit and Investment Risk Disclosure* requires that the Pinelands Commission disclose bank deposits that are subject to custodial credit risk. The custodial credit risk for deposits is the risk that, in the event of a failure of a depository financial institution, the Commission will not be able to recover deposits or will not be able to recover collateral securities that may be in the possession of an outside party. As of June 30, 2022, the Commission's confirmed

bank balances amounted to \$230,154.38, and \$0 was exposed to custodial credit risk as uninsured and uncollateralized.

The balance of the Commission’s cash and cash equivalents are deposited in the New Jersey Cash Management Fund (CMF). The CMF is governed by regulations of the State Investment Council, which prescribe standards designed to ensure the quality of investments in order to minimize risk to the CMF’s participants. An amount totaling \$11,702,611 is deposited with the CMF as of June 30, 2022; the Commission had \$164,977 in the operating account and \$629 in petty cash. The State of New Jersey, Department of the Treasury, Division of Investment, issues publicly available financial reports that include the financial statements of the CMF. The financial reports may be obtained by writing to:

State of New Jersey
 Department of the Treasury
 Division of Investment
 P.O. Box 290
 Trenton, New Jersey 08625-0290

Note 3: FIXED ASSETS

The following schedule is a summarization of general fixed assets by source as of June 30, 2022:

	Balance	Balance	Balance	Balance
	<u>June 30, 2021</u>	<u>Additions</u>	<u>Deletions</u>	<u>June 30, 2022</u>
Furniture/Equipment	\$ 1,129,821	\$ 52,408	\$ 74,554	\$ 1,107,675
Vehicles	<u>110,720</u>	<u>-</u>	<u>20,349</u>	<u>90,371</u>
Total	<u>\$ 1,240,541</u>	<u>\$ 52,408</u>	<u>\$ 94,903</u>	<u>\$ 1,198,046</u>

Note 4: LEASES

Lease Obligations – At June 30, 2022, the Commission had two operating lease agreements in effect. The Commission is paying monthly rental charges for a copy machine and scanner under separate agreements. Payments under the month-to-month rentals for the fiscal year ended June 30, 2022 were \$4,488.

Note 5: RETIREMENT SYSTEM

All required employees of the Commission are covered by the Public Employees' Retirement System (PERS), which has been established by state statute and is administered by the New Jersey Division of Pensions and Benefits (division). According to the State of New Jersey Administrative Code, all obligations of the systems will be assumed by the State of New Jersey should the system terminate. The division issues a publicly available financial report that includes financial

statements and required supplementary information. That report may be obtained by writing to:

State of New Jersey Division of Pensions and Benefits
P.O. Box 295
Trenton, New Jersey 08625-0295

<http://www.nj.gov/treasury/pensions/gasb-notices.shtml>

General Information about the Pension Plan

Description of Retirement Plan

PERS – PERS is a cost-sharing multiple-employer defined benefit pension plan which was established as of January 1, 1955, under the provisions of N.J.S.A. 43:15A. The designated purpose of the PERS is to provide retirement, death, disability, and medical benefits to certain qualified members. Membership in the PERS is mandatory for substantially all full-time employees of the State of New Jersey or any county, municipality, school district, or public agency, provided the employee is not required to be a member of another state-administered retirement system or other state pension fund or local jurisdiction's pension fund.

Vesting and Benefit Provisions

PERS – The vesting and benefit provisions are set by N.J.S.A. 43:15A and 43:3B. The PERS provides retirement, death and disability benefits. All benefits vest after ten years of service, except for medical benefits, which vest after 25 years of service or under the disability provisions of the PERS.

The following represents the membership tiers for PERS:

Tier	Definition
1	Members who were enrolled prior to July 1, 2007
2	Members who were eligible to enroll on or after July 1, 2007 and prior to November 2, 2008
3	Members who were eligible to enroll on or after November 2, 2008 and prior to May 22, 2010
4	Members who were eligible to enroll on or after May 22, 2010 and prior to June 28, 2011
5	Members who were eligible to enroll on or after June 28, 2011

Service retirement benefits of 1/55th of final average salary for each year of service credit is available to tiers 1 and 2 members upon reaching age 60 and to tier 3 members upon reaching age 62. Service retirement benefits of 1/60th of final average salary for each year of service credit is available to tier 4 members upon reaching age 62 and tier 5 members upon reaching age 65. Early retirement benefits

are available to tiers 1 and 2 members before reaching age 60, tiers 3 and 4 before age 62 with 25 or more years of service credit and tier 5 with 30 or more years of service credit before age 65. Benefits are reduced by a fraction of a percent for each month that a member retires prior to the age at which a member can receive full early retirement benefits in accordance with their respective tier. Tier 1 members can receive an unreduced benefit from age 55 to age 60 if they have at least 25 years of service. Deferred retirement is available to members who have at least 10 years of service credit and have not reached the service retirement age for the respective tier.

Contributions

PERS – The contribution policy is set by N.J.S.A. 43:15A and requires contributions by active members and contributing employers. Members contribute at a uniform rate. Pursuant to the provisions of Chapter 78, P.L. 2011, the active member contribution rate increased from 5.5% of annual compensation to 6.5% plus an additional 1% phased-in over seven years beginning in July 2012.

The member contribution rate was 7.50% in state fiscal year 2021. The phase-in of the additional incremental member contribution rate takes place in July of each subsequent state fiscal year. The rate for members who are eligible for the Prosecutors Part of PERS (Chapter 366, P.L. 2001) was 10%. Employers' contribution amounts are based on an actuarially determined rate. The Commission's contribution amounts are based on an actuarially determined amount, which includes the normal cost and unfunded accrued liability.

The Commission's contractually required contribution rate for the fiscal year ended June 30, 2022 was 17.23% of the Commission's covered payroll. This amount was actuarially determined as the amount that, when combined with employee contributions, is expected to finance the costs of benefits earned by employees during the year, including an additional amount to finance any unfunded accrued liability.

Based on the most recent PERS measurement date of June 30, 2021, the Commission's contractually required contribution to the pension plan for the fiscal year ended June 30, 2022 was \$555,312, and was paid on April 5, 2023. The Commission's contractually required contribution to the pension plan for the fiscal year ended June 30, 2021 was \$486,504 and was paid by April 7, 2022. Commission employee contributions to the pension plan during the fiscal year ended June 30, 2022 were \$266,381.

Pension Liabilities, Pension Expense, and Deferred Outflows of Resources and Deferred Inflows of Resources Related to Pensions

PERS – At June 30, 2022, the Commission's proportionate share of the net pension liability was \$4,921,262. The net pension liability was measured as of June

30, 2021, and the total pension liability used to calculate the net pension liability was determined by an actuarial valuation as of July 1, 2020. The total pension liability was calculated through the use of updated procedures to roll forward from the actuarial valuation date to the measurement date of June 30, 2021. The Commission's proportion of the net pension liability was based on a projection of the Commission's long-term share of contributions to the pension plan relative to the projected contributions of all participating employers, actuarially determined. For the June 30, 2021 measurement date, the Commission's proportion was .0415419059%, which was a decrease of .0043558226% from its proportion measured as of June 30, 2020.

For the fiscal year ended June 30, 2022, the Commission proportionate share of the pension benefit was \$556,083. This pension benefit was based on the pension plan's June 30, 2021 measurement date. This benefit is not recognized by the Commission because of the basis of accounting as described in Note 1; however, as previously mentioned for the fiscal year ended June 30, 2022 the Commission's contribution to PERS was \$486,504 and was paid by April 7, 2022.

At June 30, 2021, the Commission reported deferred outflows of resources and deferred inflows of resources related to PERS from the following sources:

	Deferred Outflows of Resources	Deferred Inflows of Resources
Differences between expected and actual experience	\$ 77,615	\$ 35,230
Changes of assumptions	22,630	1,752,001
Net difference between projected and actual earnings on pension plan investments	-	1,296,390
Changes in proportion	804,249	776,162
Commission contributions subsequent to the measurement date	555,312	
	<u>\$ 1,459,806</u>	<u>\$ 3,859,783</u>

The amount of \$555,312, included in deferred outflows of resources, will be included as a reduction of the net pension liability in the fiscal year ending June 30, 2023. Other amounts reported as deferred outflows of resources and deferred inflows of resources related to pensions will be recognized in pension expense as follows:

Fiscal Year	
Ending June 30	Amount
2023	\$ (1,049,696)
2024	(719,880)
2025	(573,106)
2026	(585,742)
2027	<u>(23,865)</u>
	<u>\$ (2,952,289)</u>

The amortization of the above other deferred outflows of resources and deferred inflows of resources related to pensions will be over the following number of years:

	Deferred Outflows of Resources (in years)	Deferred Inflows of Resources (in years)
Differences between expected and actual experience		
Year of pension plan deferral:		
June 30, 2015	5.72	-
June 30, 2016	5.57	-
June 30, 2017	5.48	-
June 30, 2018	-	5.63
June 30, 2019	5.21	-
June 30, 2020	5.16	-
June 30, 2021	-	5.13
Changes of assumptions		
Year of pension plan deferral:		
June 30, 2015	5.72	-
June 30, 2016	5.57	-
June 30, 2017	-	5.48
June 30, 2018	-	5.63
June 30, 2019	-	5.21
June 30, 2020	-	5.16
June 30, 2021	5.13	-
Net difference between projected and actual earnings on pension plan investments		
Year of pension plan deferral:		
June 30, 2015	5.00	-
June 30, 2016	5.00	-
June 30, 2017	-	5.00
June 30, 2018	-	5.00
June 30, 2019	5.00	-
June 30, 2020	5.00	-
June 30, 2021	-	5.00
Changes in proportion		
Year of pension plan deferral:		
June 30, 2015	5.72	5.72
June 30, 2016	5.57	5.57
June 30, 2017	5.48	5.48
June 30, 2018	5.63	5.63
June 30, 2019	5.21	5.21
June 30, 2020	5.16	5.16
June 30, 2021	5.13	5.13

Actuarial Assumptions

The net pension liability was measured as of June 30, 2021, and the total pension liability used to calculate the net pension liability was determined by an actuarial valuation as of July 1, 2020. The total pension liability was calculated through the use of updated procedures to roll forward from the actuarial valuation date to the measurement date of June 30, 2021. This actuarial valuation used the following actuarial assumptions, applied to all periods included in the measurement:

	<u>PERS</u>
Inflation - Price	2.75%
Inflation - Wage	3.25%
Salary increases	
FY 2017 to 2026	2.00% - 6.00% Based on Years of Service
FY 2026 and thereafter	3.00% - 7.00% Based on Years of Service
Investment rate of return	7.00%
Mortality rate table	Pub-2010
Period of actuarial experience	
study upon which actuarial	
assumptions were based	July 1, 2014 - June 30, 2018

For PERS, pre-retirement mortality rates were based on the Pub-2010 General Below-Median Income Employee mortality table with an 82.2% adjustment for males and 101.4% adjustment for females, and with future improvement from the base year of 2010 on a generational basis. Post-retirement mortality rates were based on the Pub-2010 General Below-Median Income Healthy Retiree mortality table with a 91.4% adjustment for males and 99.7% adjustment for females, and with future improvement from the base year of 2010 on a generational basis. Disability retirement rates used to value disabled retirees were based on the Pub-2010 Non-Safety Disabled Retiree mortality table with a 127.7% adjustment for males and 117.2% adjustment for females, and with future improvement from the base year of 2010 on a generational basis. Mortality improvement is based on Scale MP-2021.

In accordance with state statute, the long-term expected rate of return on plan investments (7.00% at June 30, 2021) is determined by the State Treasurer, after consultation with the Directors of the Division of Investment and Division of Pensions and Benefits, the board of trustees and the actuaries.

The long-term expected rate of return was determined using a building block

method in which best-estimate ranges of expected future real rates of return (expected returns, net of pension plan investment expense and inflation) are developed for each major asset class.

These ranges are combined to produce the long-term expected rate of return by weighting the expected future real rates of return by the target asset allocation percentage and by adding expected inflation. Best estimates of arithmetic rates of return for each major asset class included in PERS’s target asset allocation as of June 30, 2021, are summarized in the following table:

<u>Asset Class</u>	<u>PERS</u>	
	<u>Target Allocation</u>	<u>Long-Term Expected Real Rate of Return</u>
Absolute Return/Risk Mitigation	3.00%	3.35%
Cash Equivalents	4.00%	0.50%
U.S. Treasuries	5.00%	0.95%
Investment Grade Credit	8.00%	1.68%
Public High Yield	2.00%	3.75%
Private Credit	8.00%	7.60%
Real Assets	3.00%	7.40%
Real Estate	8.00%	9.15%
U.S. Equity	27.00%	8.09%
Non-U.S. Developed Markets Equity	13.50%	8.71%
Emerging Market Equity	5.50%	10.96%
Private Equity	<u>13.00%</u>	11.30%
	<u>100.00%</u>	

Discount Rate – The discount rates used to measure the total pension liability at June 30, 2021 was 7.00%. The projection of cash flows used to determine the discount rate assumed that contributions from plan members will be made at the current member contribution rates and that contributions from employers and the non-employer contributing entity will be based on 100% of the actuarially determined contributions for the state employer and 100% of actuarially determined contributions for the local employers. Based on those assumptions, the plan’s fiduciary net position was projected to be available to make all projected future benefit payments of current plan members. Therefore, the long-term expected rate of return on plan investments was applied to all projected benefit payments to determine the total pension liability.

Sensitivity of Commission’s Proportionate Share of Net Pension Liability to Changes in the Discount Rate

PERS – The following presents the Commission’s proportionate share of the net pension liability at June 30, 2021, the plans measurement date, calculated using a discount rate of 7.00%, as well as what the Commission’s proportionate share of the net pension liability would be if it were calculated using a discount rate

that is 1% lower or 1% higher than the current rates used:

	PERS		
	1%	Current	1%
	Decrease	Discount Rate	Increase
	(6.00%)	(7.00%)	(8.00%)
Commission's proportionate share of the net pension liability	\$ 6,773,201	\$ 4,973,722	\$ 3,446,609

Pension Plan Fiduciary Net Position

For purposes of measuring the net pension liability, deferred outflows of resources and deferred inflows of resources related to pensions, and pension expense, information about the respective fiduciary net position of the PERS and additions to/deductions from PERS’s fiduciary net position have been determined on the same basis as they are reported by PERS. Accordingly, benefit payments (including refunds of employee contributions) are recognized when due and payable in accordance with the benefit terms. Investments are reported at fair value. For additional information about PERS, please refer to the plan’s Annual Comprehensive Financial Report (ACFR) which can be found at: <https://www.nj.gov/treasury/pensions/financial-reports.shtml>.

Note 6: HEALTH CARE BENEFITS

The Commission provides health care benefits, through the New Jersey State Health Benefits Program, to all continuing employees who are scheduled to work 25 or more hours per week, along with their spouses and eligible dependents. Expenditures for health care benefits are recognized on a pay-as-you-go basis.

In accordance with P. L. 2011, Chapter 78, employees enrolled in the New Jersey State Health Benefits Program are required to contribute a portion of their bi-weekly salary. The balance of the monthly health care benefits premium is paid by the Commission, which receives a credit from the state. Employees covered by other health insurance can elect to waive coverage and receive \$1,000 annually.

The Commission’s health care benefits premiums, including employees’ contributions, are as follows:

Health Care Costs				
Fiscal Year	Premium	Costs to Commission	Employee Contributions	Credit from State
2022	\$ 772,733	\$ (92,019)	\$ 177,753	\$ 687,000
2021	725,594	(14,786)	174,373	566,007
2020	789,947	37,872	168,970	583,105
2019	817,394	105,692	174,699	537,003
2018	806,293	135,627	154,447	516,219
2017	798,708	152,158	134,323	512,227
2016	797,988	152,839	134,285	510,864

Note 7: POSTEMPLOYMENT BENEFITS OTHER THAN PENSION BENEFITS (OPEB)

General Information about the OPEB Plan

Plan Description and Benefits Provided – The Commission contributes to the State Health Benefits Local Government Retired Employees Plan (plan), which is a cost-sharing multiple-employer defined benefit other postemployment benefit plan. It covers employees of local government employers that have adopted a resolution to participate in the plan. The plan meets the definition of an equivalent arrangement as defined in GASB Statement No. 75, *Accounting and Financial Reporting for the Postemployment Benefits Other Than Pensions*; therefore, assets are accumulated to pay associated benefits. For additional information about the plan, please refer to the State of New Jersey, Division of Pensions and Benefits’ Annual Comprehensive Financial Report, which can be found at:

<https://www.state.nj.us/treasury/pensions/financial-reports.shtml>.

The plan provides medical and prescription drug benefits to retirees and their covered dependents of the employers. Under the provisions of P.L. 1974, c.88 and Chapter 48, P.L. 1999, local government employers electing to provide post-retirement medical coverage to their employees must file a resolution with the division. Under Chapter 88, local employers elect to provide benefit coverage based on the eligibility rules and regulations promulgated by the State Health Benefits Commission. Chapter 48 allows local employers to establish their own age and service eligibility for employer-paid health benefits coverage for retired employees. Under Chapter 48, the employer may assume the cost of post-retirement medical coverage for employees and their dependents who: 1) retired on a disability pension; or 2) retired with 25 or more years of service credit in a state or locally administered retirement system and a period of service of up to 25 years with the employer at the time of retirement as established by the employer; or 3) retired and reached the age of 65 with 25 or more years of service credit in a state or locally administered retirement system and a period of service of up to 25 years with the employer at the time of retirement as established by the employer; or 4) retired and reached age 62 with at least 15 years of service with the employer. Further, the law provides that the employer paid

obligations for retiree coverage may be determined by means of a collective negotiations agreement.

Pursuant to Chapter 78, P.L. 2011, future retirees eligible for post-retirement medical coverage who have less than 20 years of creditable service on June 28, 2011 will be required to pay a percentage of the cost of their pension service credit. The percentage of the premium for which the retiree will be responsible will be determined based on the retiree's annual retirement benefit and level of coverage.

Contributions – The funding policy for the OPEB plan is pay-as-you-go; therefore, there is no prefunding of the liability. However, due to premium rates being set prior to each calendar year, there is a minimal amount of net position available to cover benefits in future years. Contributions to pay for the health benefit premiums of participating employees in the OPEB plan are collected from participating local employers and retired members.

The Commission was billed monthly by the plan and has expended \$181,838 for the fiscal year ended June 30, 2022, representing 5.64% of the Commission's covered payroll. The Commission has recognized revenue in the amount of \$136,690 for a credit from the State of New Jersey to cover retiree health benefits; however, this credit has no effect on the calculations in the plan. At June 30, 2022, there were no retirees required to pay a percentage of the cost of their health care coverage.

OPEB Liability, OPEB Expense, and Deferred Outflows of Resources and Deferred Inflows of Resources

OPEB Liability – At June 30, 2022, the Commission's proportionate share of the net OPEB liability was \$9,549,964. The net OPEB liability was measured as of June 30, 2021, and the total OPEB liability used to calculate the net OPEB liability was determined by an actuarial valuation as of June 30, 2020, which was rolled forward to June 30, 2021.

The Commission's proportion of the net OPEB liability was based on the ratio of the plan members of an individual employer to the total members of the plan's nonspecial funding situation during the measurement period July 1, 2020 through June 30, 2021. For the June 30, 2021 measurement date, the Commission's proportion was .053056%, which was a decrease of .000687% from its proportion measured as of the June 30, 2020 measurement date.

OPEB Expense – At June 30, 2022, the Commission's proportionate share of the OPEB expense, calculated by the plan as of June 30, 2021 measurement date, is \$28,202. This expense is not recognized by the Commission because of the basis of the accounting as described in Note 1; however, as previously mentioned, for the fiscal year ended June 30, 2022, the Commission made contributions to the plan totaling \$181,838.

Deferred Outflows of Resources and Deferred Inflows of Resources – At June 30, 2022, the Commission had deferred outflows of resources and deferred inflows of resources related to the OPEB liability from the following sources:

	Deferred Outflows of Resources	Deferred Inflows of Resources
Differences between expected and actual experience	\$ 214,290	\$ 1,997,993
Changes of assumptions	1,373,791	1,688,068
Net difference between projected and actual earnings on OPEB plan investments	4,566	-
Changes in proportion	163,811	473,048
Commission contributions subsequent to the measurement date	181,838	-
	<u>\$ 1,938,296</u>	<u>\$ 4,159,109</u>

The amount of \$181,838, included in deferred outflows of resources, resulting from the Commission's contributions subsequent to the measurement date, will be included as a reduction of the Commission's net OPEB liability in the fiscal year ending June 30, 2023.

The Commission will amortize the other deferred outflows of resources and deferred inflows of resources related to the OPEB liability over the following number of years:

	Deferred Outflows of Resources (in years)	Deferred Inflows of Resources (in years)
Changes of assumptions		
June 30, 2018	-	8.14
June 30, 2019	-	8.05
June 30, 2020	7.87	-
June 30, 2021	7.82	-
Net difference between projected and actual earnings on OPEB plan investments		
June 30, 2018	5.00	-
June 30, 2019	5.00	-
June 30, 2020	5.00	-
June 30, 2021	5.00	-
Net difference between expected and actual experience		
June 30, 2018	-	8.14
June 30, 2019	-	8.05
June 30, 2020	7.87	-
June 30, 2021	-	7.82
Changes in proportion		
June 30, 2018	8.14	8.14
June 30, 2019	8.05	8.05
June 30, 2020	7.87	7.87
June 30, 2021	7.82	7.82

Other amounts included as deferred outflows of resources and deferred inflows of resources related to the OPEB liability will be recognized in future periods as follows:

Fiscal Year	Amount
<u>Ending June 30,</u>	<u>Amount</u>
2023	\$ (615,564)
2024	(616,314)
2025	(617,000)
2026	(453,565)
2027	(113,968)
Thereafter	<u>13,760</u>
Total	<u>\$ (2,402,651)</u>

Actuarial Assumptions

The actuarial assumptions vary for each plan member depending on the pension plan in which the member is enrolled. The total OPEB liability as of June 30, 2022 was determined by an actuarial valuation as of July 1, 2021, which was rolled forward to June 30, 2022.

The actuarial valuation at June 30, 2021 used the following actuarial assumptions, applied to all periods in the measurement:

	<u>Actuarial Assumptions</u>
Inflation	2.50%
*Salary increases:	
Through 2026	2.00% - 6.00%
Thereafter	<u>3.00% - 7.00%</u>

*Salary increases are based on the years of service within the respective plan.

Pre-retirement mortality rates were based on the Pub-2010 Headcount-Weighted Healthy Employee Male/Female mortality table with fully generational mortality improvement projections from the central year using the MP-2021 scale. Post-retirement mortality rates were based on the Pub-2010 Headcount-Weighted Healthy Annuitant Male/Female mortality table with fully generational improvement projections from the central year using the MP-2021 scale. Disability mortality was based on the Pub-2010 Headcount-Weighted Disabled Male/Female mortality table with fully generational improvement projections from the central year using the MP-2021 scale.

Certain actuarial assumptions used in the July 1, 2021 valuation were based on the results of the pension plan’s experience study for which the members are eligible for coverage under this plan, the Public Employees’ Retirement System (PERS). The PERS experience study was prepared for the period July 1, 2018 to June 30, 2021.

Discount Rate – The discount rate used to measure the OPEB Liability at June 30, 2021 was 2.16%. This represents the municipal bond return rate as chosen by the state. The source is the Bond Buyer Go 20-Bond Municipal Bond Index, which includes tax-exempt general obligation municipal bonds with an average rating of AA/Aa or higher. As the long-term rate of return is less than the municipal bond rate, it is not considered in the calculation of the discount rate, rather the discount rate is set at the municipal bond rate.

Health Care Trend Assumptions – The trend rate for pre-Medicare medical benefits is initially 5.65 percent and decreases to a 4.50 percent long-term trend rate after seven years. For post-65 medical benefits, the actual fully-insured Medicare Advantage trend rates for fiscal year 2022 and 2023 are reflected. Future years preferred provider organization (PPO) and health maintenance organization (HMO) medical benefits trend rates differ for each retirement plan. The preferred provider organization (PPO) trend is initially 7.56% in fiscal year 2024, increasing to 14.43% in fiscal year 2025 and decreasing to 4.50% after 11 years. The HMO trend is initially 7.79% in fiscal year 2024, increasing to 15.23% in fiscal year 2025 and decreasing to 4.50% after 11 years. For prescription drug benefits, the initial trend rate is 6.75% and decreases to 4.50% long-term after 7 years.

Sensitivity of the Net OPEB Liability to Changes in the Discount Rate – The Commission’s net OPEB liability as of the plan’s June 30, 2021 measurement date calculated using a discount rate of 2.16%, as well as using a discount rate that is 1% lower or 1% higher than the current rates used, is as follows:

	1% Decrease (1.16%)	Current Discount Rate (2.16%)	1% Increase (3.16%)
Commission's proportionate share of Net OPEB liability	\$ 11,238,476	\$ 9,549,964	\$ 8,211,782

Sensitivity of the Net OPEB Liability to Changes in the Healthcare Cost Trend Rates – The Commission’s proportionate share of the net OPEB Liability as of June 30, 2021, using a healthcare cost trend rates that are 1% lower or 1% higher than the current healthcare cost trend rate used is as follows:

	1%	Healthcare Cost Trend	1%
	Decrease	Rate	Increase
Commission's proportionate share of the net OPEB liability	\$ 7,967,886	\$ 9,549,964	\$ 11,614,379

OPEB Plan Fiduciary Net Position

For purposes of measuring the net OPEB liability, deferred outflows of resources and deferred inflows of resources related to OPEB, and OPEB expense, information about the respective fiduciary net position of the State Health Benefits Local Government Retired Employees' Plan and additions to / deductions from the plan's respective fiduciary net position have been determined on the same basis as they are reported by the plan. Accordingly, contributions (including refunds of employee contributions) are recognized when due and payable in accordance with the benefit terms. Investments are reported at fair value. For additional information about the plan, please refer to the plan's Annual Comprehensive Financial Report which can be found at: <https://www.state.nj.us/treasury/pensions/financial-reports.shtml>.

Note 8: RISK MANAGEMENT

The Commission is exposed to various risks of loss related to torts; theft of, damage to, and destruction of assets; errors and omissions; injuries to employees; and natural disasters.

Property and Liability Insurance – The Commission maintains an umbrella policy and commercial insurance coverage for property, general liability, commercial auto, and worker's compensation.

New Jersey Unemployment Compensation Insurance – In 1979, the Commission elected to fund its New Jersey Unemployment Compensation Insurance under the "Benefit Reimbursement Method". Under this plan, the Commission is required to reimburse the New Jersey Unemployment Compensation Fund for benefits paid to its former employees and charged to its account with the state. The Commission is billed quarterly for amounts due to the state. The following is a summary of employee contributions, reimbursements to the state for benefits paid, and the ending balance of the Commission's trust fund for the current and previous four years:

Fiscal Year	Employee Contribution	Annual Reimbursement	Funding Balance *
2022	\$ -	\$ -	\$ 3,655
2021	-	-	3,602
2020	419	-	3,586
2019	4,454	16,614	2,724
2018	6,334	872	14,302

* Includes annual interest income

Note 9: LONG-TERM DEBT

Compensated Absences – The Commission’s policy states that employees are entitled, upon termination, to the current year’s earned but unused vacation time in addition to any unused vacation time previously earned. In addition, employees are eligible, at retirement, to receive payment for one-half of their accumulated sick leave up to a maximum of \$15,000. Unused vacation time expected to be taken in the succeeding fiscal year in the amount of \$46,368 has been recorded as a liability in the General Fund on the accompanying balance sheet.

A liability for vested compensated absences has also been established in the General Long-Term Debt Account Group as the benefits accrue to employees. As of June 30, 2022, the estimated long-term liability for compensated absences was \$611,443. Net long-term debt as of June 30, 2022 is as follows:

	Balance 6/30/2021	Additions	Deductions	Balance 6/30/2022	Due Within One Year
Compensated absences payable	\$ 77,844	\$ -	\$ 31,476	\$ 46,368	\$ 46,368
Estimated compensated absences payable	620,102	13,696	22,355	611,443	-
Total	\$ 697,946	\$ 13,696	\$ 53,831	\$ 657,811	\$ 46,368

Note 10: INTERFUND RECEIVABLES AND PAYABLES

The following interfund balances remained on the balance sheet at June 30, 2022:

Fund	Interfund Receivable	Interfund Payable
General Fund	\$ 960,871	\$ -
Special Revenue Funds	\$ 21,918	\$ 950,846
Private Purpose Trust Funds	\$ -	\$ 31,943
Total	\$ 982,789	\$ 982,789

The interfund receivables and payables above predominately resulted from collections and payments made by certain funds on behalf of the other funds. During

the fiscal year 2022, the Commission expects to liquidate such interfund balances, depending on the availability of cash flow.

Note 11: GASB 54 - FUND BALANCE DISCLOSURES

In accordance with GASB No. 54, *Fund Balance Reporting and Governmental Fund Type Definitions*, the Commission classifies governmental fund balances as follows:

- Non-spendable – includes fund balance amounts that cannot be spent either because it is not in spendable form or because of legal or contractual constraints.
- Restricted – includes fund balance amounts that are constrained for specific purposes which are externally imposed by external parties, constitutional provision, or enabling legislation.
- Committed – includes fund balance amounts that are constrained for specific purposes that are internally imposed by the government through formal action of the highest level of decision-making authority and does not lapse at year-end.
- Assigned – includes fund balance amounts that are intended to be used for specific purposes that are neither considered restricted nor committed. Fund Balance may be assigned by the Executive Director or the Board of Commissioners.
- Unassigned – includes balance within the General Fund that has not been classified within the above-mentioned categories and negative fund balances in other governmental funds.

Specific reservations of fund balances are described below:

RESTRICTED FOR:

Unemployment Compensation – This reserve was established with funds contributed by employees and used to reimburse the state for benefits paid, \$3,655.

Katie Fund – The Kathleen M. Lynch-van de Sande Fund consists of contributions from the public which are dedicated to the support of reforestation and vegetation activities in the Pinelands and to further educational programs and projects that enhance the understanding of the Pinelands National Reserve, \$(3,155).

Timber Rattlesnake Study – This reserve was created as a result of a settlement in order to fund an escrow for the study and monitoring of the timber rattlesnakes in and near a particular development site, \$6,690.

Rattlesnake Fencing – This reserve was created to account for funds restricted for possible future fencing necessitated by the above rattlesnake study, \$21,796.

COMMITTED TO:

Pinelands Conservation Fund – This reserve was established with funds provided

by the Atlantic Electric Co. as a result of the proposed electric transmission line project to further the Pinelands protection program and ensure a greater level of protection for the unique resources of the Pinelands area, \$4,808,281.

Kirkwood-Cohansey Study – This reserve was created from funds from the Water Supply Fund to assess and prepare a report on the key hydrological and ecological information needed to determine how the current and future water supply needs of the Pinelands may be met while protecting the Kirkwood-Cohansey aquifer system and avoiding any adverse ecological impact, \$62,691.

Encumbrances – The reserve for encumbrances was created to represent encumbrances outstanding at the end of the year based on purchase orders and contracts signed by the Commission but not completed as of the close of the fiscal year, \$145,889.

Retirees' Health Benefits – This is a designation of fund balance that the Commission intends to use to fund future retirees' health benefits, \$799,155.

Investment in General Fixed Assets – This represents the amount invested in fixed assets, \$1,198,046.

ASSIGNED TO:

Subsequent Year's Expenditures – This designation of fund balance has been appropriated and included as anticipated revenue for the year ending June 30, 2023, \$1,517,475.

Other – This represents designations of fund balance that the Commission intends to use for various projects, such as Pinelands poster reprinting and service awards, \$83,458.

UNASSIGNED FUND BALANCE:

Unassigned – This represents the portion of fund balance resources available for appropriation, \$1,498,915.

Note 12: ECONOMIC DEPENDENCY

The Commission receives a significant portion of its total revenues from the State of New Jersey. Because these revenues are subject to annual appropriation, any reduction in the amount appropriated in the state's budget will have a material impact on the operations of the Commission. A comparison of annual operating revenues is shown in the following chart:

Fiscal Year	Total State Aid Revenues	General Fund Revenues*	Percentage
2022	\$ 3,936,000	\$ 5,553,547	71%
2021	3,786,000	5,249,677	72%
2020	3,636,000	4,659,249	78%
2019	3,486,000	5,335,483	65%
2018	3,336,000	4,342,259	77%

* Includes transfers from other funds

Required Supplementary Information

NEW JERSEY PINELANDS COMMISSION
SCHEDULE OF THE COMMISSION'S PROPORTIONATE SHARE OF THE NET PENSION LIABILITY
PUBLIC EMPLOYEES' RETIREMENT SYSTEMS (PERS) - LOCAL
REQUIRED SUPPLEMENTARY INFORMATION

	Measurement date ending June 30			
	2021	2020	2019	2018
Commission's Proportion of the Net Pension Liability	0.0415419059%	0.0458977285%	0.0424035874%	0.0396726809%
Commission's Proportionate Share of the Net Pension Liability	\$ 4,921,262	\$ 7,484,719	\$ 7,640,483	\$ 7,811,353
Commission's Covered Payroll (Plan Measurement Period)	\$ 3,044,356	\$ 3,255,936	\$ 2,964,972	\$ 2,664,084
Commission's Proportionate Share of the Net Pension Liability as a Percentage of Covered Payroll	161.65%	229.88%	257.69%	293.21%
Plan Fiduciary Net Position as a Percentage of the Total Pension Liability (local)	70.33%	58.32%	56.27%	53.60%

NEW JERSEY PINELANDS COMMISSION
SCHEDULE OF THE COMMISSION'S PROPORTIONATE SHARE OF THE NET PENSION LIABILITY
PUBLIC EMPLOYEES' RETIREMENT SYSTEMS (PERS) - LOCAL
REQUIRED SUPPLEMENTARY INFORMATION

	Measurement date ending June 30				
	2017	2016	2015	2014	2013
Commission's Proportion of the Net Pension Liability	0.0387524433%	0.0393468730%	0.0385232928%	0.0406718663%	0.0394699485%
Commission's Proportionate Share of the Net Pension Liability	\$ 9,020,949	\$ 11,653,415	\$ 8,647,707	\$ 7,614,886	\$ 7,543,491
Commission's Covered Payroll (Plan Measurement Period)	\$ 2,713,988	\$ 2,706,800	\$ 2,739,132	\$ 2,796,096	\$ 2,698,088
Commission's Proportionate Share of the Net Pension Liability as a Percentage of Covered Payroll	332.39%	430.52%	315.71%	272.34%	279.59%
Plan Fiduciary Net Position as a Percentage of the Total Pension Liability (local)	48.10%	40.14%	47.93%	52.08%	48.72%

Note: Until a full ten-year trend is completed, information will be presented for years for which information is available.

NEW JERSEY PINELANDS COMMISSION
SCHEDULE OF THE COMMISSION'S CONTRIBUTIONS
PUBLIC EMPLOYEES' RETIREMENT SYSTEM (PERS) - LOCAL
REQUIRED SUPPLEMENTARY INFORMATION

	Fiscal Year Ended June 30									
	2022	2021	2020	2019	2018	2017	2016	2015	2014	2013
Contractually Required Contribution	\$ 555,312	\$ 486,504	\$ 502,099	\$ 412,464	\$ 394,615	\$ 359,000	\$ 349,552	\$ 331,197	\$ 335,293	\$ 297,398
Contributions in Relation to the Contractually Required Contribution	<u>(555,312)</u>	<u>(486,504)</u>	<u>(502,099)</u>	<u>(412,464)</u>	<u>(394,615)</u>	<u>(359,000)</u>	<u>(349,552)</u>	<u>(331,197)</u>	<u>(335,293)</u>	<u>(297,398)</u>
Contribution Deficiency (Excess)	<u>\$ -</u>	<u>\$ -</u>	<u>\$ -</u>	<u>\$ -</u>	<u>\$ -</u>	<u>\$ -</u>	<u>\$ -</u>	<u>\$ -</u>	<u>\$ -</u>	<u>\$ -</u>
Commission's Covered Payroll (Fiscal Year)	<u>\$ 3,222,574</u>	<u>\$ 3,060,315</u>	<u>\$ 3,170,017</u>	<u>\$ 3,140,268</u>	<u>\$ 2,915,910</u>	<u>\$ 2,692,751</u>	<u>\$ 2,707,759</u>	<u>\$ 2,697,688</u>	<u>\$ 2,697,688</u>	<u>\$ 2,725,516</u>
Contributions as a Percentage of Commission's Covered Payroll	17.23%	15.90%	15.84%	13.13%	13.53%	13.33%	12.91%	12.28%	12.43%	10.91%

Changes in Benefit Terms

None

Changes in Assumptions

The discount rate remained at 7.00% as of June 30, 2020.

In the July 1, 2019 actuarial valuation the mortality improvement was based on Scale MP-2020 while in the July 1, 2020 actuarial valuation the mortality improvements was based on Scale MP-2021.

NEW JERSEY PINELANDS COMMISSION
SCHEDULE OF CHANGES IN THE TOTAL OPEB LIABILITY AND THE COMMISSION'S PROPORTIONATE SHARE OF THE NET OPEB LIABILITY
STATE HEALTH BENEFIT RETIRED EMPLOYEES' OPEB PLAN
REQUIRED SUPPLEMENTARY INFORMATION

	Measurement date ending June 30					
	2021	2020	2019	2018	2017	2016
Total Net OPEB Liability:						
Service cost	\$ 846,075,674	\$ 605,949,339	\$ 666,574,660	\$ 896,235,148	\$ 1,064,525,862	\$ 793,330,866
Interest	413,837,061	497,444,533	636,082,461	764,082,232	648,423,508	693,228,312
Changes of Benefit Terms	2,029,119	1,034,142	(1,903,958)	-	-	-
Differences between expected and actual experience	(1,196,197,410)	541,506,395	(1,399,921,930)	(3,626,384,047)	-	-
Changes in assumptions or other inputs	339,165,715	3,074,968,821	(1,635,760,217)	(2,314,240,675)	(2,587,850,974)	3,126,488,338
Net investment income	(201,343)	(2,858,334)	(4,826,936)	(2,320,422)	(791,049)	(310,043)
Contributions from employers and non- employers	(362,874,910)	(327,416,317)	(390,269,556)	(474,742,947)	(434,877,635)	(397,482,072)
Administrative expense	11,334,383	9,913,267	9,478,435	8,200,113	8,894,576	528,244
Net Change in Total Net OPEB Liability	\$ 53,168,289.00	\$ 4,400,541,846.00	\$(2,120,547,041.00)	\$(4,749,170,598.00)	\$(1,301,675,712.00)	\$ 4,215,783,645.00
Total OPEB Liability, beginning	17,946,612,946	13,546,071,100	15,666,618,141	20,415,788,739	21,717,464,451	17,501,680,806
Total OPEB Liability, ending	<u>\$17,999,781,235</u>	<u>\$ 17,946,612,946</u>	<u>\$ 13,546,071,100</u>	<u>\$ 15,666,618,141</u>	<u>\$ 20,415,788,739</u>	<u>\$ 21,717,464,451</u>
Commission's Proportion of the Net OPEB Liability	0.053056%	0.053743%	0.052758%	0.054073%	0.054329%	0.055825%
Commission's Proportionate Share of the Net OPEB Liability	<u>\$ 9,549,964</u>	<u>\$ 9,645,048</u>	<u>\$ 7,146,636</u>	<u>\$ 8,471,410</u>	<u>\$ 11,091,694</u>	<u>\$ 12,123,775</u>
Commission's Covered Payroll (Plan Measurement Period)	<u>\$ 3,060,315</u>	<u>\$ 3,170,017</u>	<u>\$ 3,140,268</u>	<u>\$ 2,915,910</u>	<u>\$ 2,692,751</u>	<u>\$ 2,707,759</u>
Commission's Proportionate Share of the Net OPEB Liability as a Percentage of Covered Payroll	312.06%	304.26%	227.58%	290.52%	411.91%	447.74%
Plan Fiduciary Net Position as a Percentage of the Total Pension Liability	0.2800%	0.9100%	1.9800%	1.9700%	1.0300%	0.6900%

Notes to Schedule:

No assets are accumulated in a trust that meets the criteria in Paragraph 45 of GASB 75

Note: In accordance with GASB 75, the above information is also presented for the State Health Benefits Local Government Retired Employees' Plan. These schedules are presented to illustrate the requirements to show information for 10 years; however, until a full 10-year trend is compiled, this presentation will only include information for those years for which information is available.

**NEW JERSEY PINELANDS COMMISSION
SCHEDULE OF THE COMMISSION'S CONTRIBUTIONS
STATE HEALTH BENEFIT RETIRED EMPLOYEES' OPEB PLAN
REQUIRED SUPPLEMENTARY INFORMATION**

	Fiscal Year Ending June 30					
	2022	2021	2020	2019	2018	2017
Commission's Required Contribution	\$ 181,838	\$ 163,364	\$ 159,893	\$ 218,955	\$ 284,092	\$ 305,161
Contributions in Relation to the Required Contribution	(181,838)	(163,364)	(159,893)	(218,955)	(284,092)	(305,161)
Contribution Deficiency (Excess)	<u>\$ -</u>	<u>\$ -</u>	<u>\$ -</u>	<u>\$ -</u>	<u>\$ -</u>	<u>\$ -</u>
Commission's Covered Payroll (Fiscal Year)	<u>\$ 3,222,574</u>	<u>\$ 3,060,315</u>	<u>\$ 3,170,017</u>	<u>\$ 3,140,268</u>	<u>\$ 2,915,910</u>	<u>\$ 2,692,751</u>
Contributions as a Percentage of Commission's Covered Payroll	5.64%	5.34%	5.04%	6.97%	9.74%	11.33%

Note: In accordance with GASB 75, the above information is also presented for the State Health Benefits Local Government Retired Employees' Plan. These schedules are presented to illustrate the requirements to show information for 10 years; however, until a full 10-year trend is compiled, this presentation will only include information for those years for which information is available.

Changes in Benefit Terms

None

Differences between Expected and Actual Experience

The increase in liability from June 30, 2020 to June 30, 2021 is due to changes in the census, claims and premium experience.

Changes in Assumptions

The increase in the liability from June 30, 2021 to June 30, 2022 is due to the decrease in the assumed discount rate from 2.21% as of June 30, 2020 to 2.16% as of June 30, 2021, as well as changes in the trend, repealment of the excise tax and updated mortality improvement assumptions.

Other Information

PINELANDS COMMISSION
 SCHEDULE OF EXPENDITURES OF STATE FINANCIAL ASSISTANCE
 FOR THE FISCAL YEAR ENDED JUNE 30, 2022

Grantor/Pass Through Grantor/Program Title	STATE GRANT or GMIS NUMBER	PROGRAM or AWARD AMOUNT	GRANT PERIOD		ACCOUNTS	DEFERRED	CASH/CREDIT		ACCOUNTS	DEFERRED
			FROM	TO	RECEIVABLE 6/30/2021	REVENUE 6/30/2021	RECEIVED	EXPENDITURES	RECEIVABLE 6/30/2022	REVENUE 6/30/2022
Department of Environmental Protection										
State Aid	100-042-4800-082	\$ 3,249,000	07/01/2021	06/30/2022	\$ -	\$ -	\$ 3,249,000	\$ 3,249,000	\$ -	\$ -
Pinelands Development Credit Purchases	100-042-4800-324	13,000,000	07/01/1999	Completion	\$ -	\$ 1,759,200	\$ -	\$ -	\$ -	\$ 1,759,200
Credit from State - Fringe Benefits	not applicable	687,000	07/01/2021	06/30/2022	\$ -	\$ -	\$ 687,000	\$ 687,000	\$ -	\$ -
Total State Financial Assistance					\$ -	\$ 1,759,200	\$ 3,936,000	\$ 3,936,000	\$ -	\$ 1,759,200

See Report and Notes to Schedules of Expenditures of State Financial Assistance.

**PINELANDS COMMISSION
NOTES TO THE SCHEDULE OF EXPENDITURES OF
STATE FINANCIAL ASSISTANCE
FOR THE FISCAL YEAR ENDED JUNE 30, 2022**

Note 1: GENERAL

The accompanying Schedule of Expenditures of State Financial Assistance presents the activity of all state financial assistance programs of the New Jersey Pinelands Commission. The Commission is defined in Note 1 to the financial statements. All state financial assistance received directly from state agencies is included on the Schedule of Expenditures of State Financial Assistance.

Note 2: BASIS OF ACCOUNTING

The accompanying Schedule of Expenditures of State Financial Assistance is presented using the modified accrual basis of accounting. This basis of accounting is described in Note 1 to the Commission's general purpose financial statements.

Note 3: RELATIONSHIP TO FINANCIAL STATEMENTS

Amounts reported in the accompanying schedule agree with amounts reported in the Commission's financial statements.

Note 4: RELATIONSHIP TO STATE FINANCIAL REPORTS

Amounts reported in the accompanying schedule agree with the amounts reported in the related state financial reports.

Note 5: MAJOR PROGRAMS

Major programs are identified in the *Summary of Auditor's Results* section of the Schedule of Audit Findings and Questioned Costs.

Pinelands Commission

**Report on Internal Control over Financial Reporting and on Compliance
and Other Matters Based on an Audit of Financial Statements Performed
in Accordance with *Government Auditing Standards***

For Fiscal Year Ended June 30, 2022

SENATE

Anthony M. Bucco
Kristin M. Corrado
Linda R. Greenstein
Joseph Pennacchio
M. Teresa Ruiz
Nicholas P. Scutari
Robert W. Singer
Shirley K. Turner



NEW JERSEY LEGISLATURE
OFFICE OF LEGISLATIVE SERVICES

David J. Kaschak
State Auditor

Brian M. Klingele
Assistant State Auditor

Robert F. Gatti
Assistant State Auditor

GENERAL ASSEMBLY

Craig J. Coughlin
Christopher P. DePhillips
John DiMaio
Louis D. Greenwald
Antwan L. McClellan
Nancy F. Muñoz
Verlina Reynolds-Jackson
Shanique Speight

125 SOUTH WARREN STREET • P.O. BOX 067 • TRENTON, NJ 08625-0067
www.njleg.gov

**REPORT ON INTERNAL CONTROL OVER FINANCIAL REPORTING AND ON
COMPLIANCE AND OTHER MATTERS BASED ON AN AUDIT OF
FINANCIAL STATEMENTS PERFORMED IN ACCORDANCE
WITH GOVERNMENT AUDITING STANDARDS**

INDEPENDENT AUDITOR'S REPORT

The Honorable Mikie Sherrill
Governor of New Jersey

The Honorable Nicholas P. Scutari
President of the Senate

The Honorable Craig J. Coughlin
Speaker of the General Assembly

Ms. Maureen McMahon
Executive Director
Office of Legislative Services

We have audited, in accordance with auditing standards generally accepted in the United States of America and the standards applicable to financial audits contained in *Government Auditing Standards* issued by the Comptroller General of the United States, the financial statements of the Pinelands Commission, as of and for the year ended June 30, 2022, and the related notes to the financial statements, and have issued our report thereon dated March 3, 2026.

Report on Internal Control over Financial Reporting

In planning and performing our audit of the financial statements, we considered the Pinelands Commission's internal control over financial reporting (internal control) as a basis for designing audit procedures that are appropriate in the circumstances for the purpose of expressing our opinions on the financial statements, but not for the purpose of expressing an opinion on the

effectiveness of the Pinelands Commission’s internal control. Accordingly, we do not express an opinion on the effectiveness of the Pinelands Commission’s internal control.

Our consideration of internal control was for the limited purpose described in the preceding paragraph and was not designed to identify all deficiencies in internal control that might be material weaknesses or significant deficiencies and therefore, material weaknesses or significant deficiencies may exist that were not identified. However, as described in the accompanying schedule of findings and responses, we identified certain deficiencies in internal control that we consider to be material weaknesses and significant deficiencies. Refer to Findings 2022-01 and 2202-02.

A deficiency in internal control exists when the design or operation of a control does not allow management or employees, in the normal course of performing their assigned functions, to prevent, or detect and correct, misstatements on a timely basis. A *material weakness* is a deficiency, or a combination of deficiencies, in internal control, such that there is a reasonable possibility that a material misstatement of the entity’s financial statements will not be prevented, or detected and corrected on a timely basis. We consider the deficiencies described in the accompanying schedule of findings and responses, Finding 2022-001, to be a material weakness.

A significant deficiency is a deficiency, or a combination of deficiencies, in internal control that is less severe than a material weakness, yet important enough to merit attention by those charged with governance. We consider the deficiencies described in the accompanying schedule of findings and responses, Finding 2022-002, to be a significant deficiency.

Report on Compliance and Other Matters

As part of obtaining reasonable assurance about whether the Pinelands Commission’s financial statements are free of material misstatement, we performed tests of its compliance with certain provisions of laws, regulations, contracts, and grant agreements, noncompliance with which could have a direct and material effect on the determination of financial statement amounts. However, providing an opinion on compliance with those provisions was not an objective of our audit, and accordingly, we do not express such an opinion. The results of our tests disclosed no instances of noncompliance or other matters that are required to be reported under *Government Auditing Standards*.

Pinelands Commission’s Response to Findings

Government Auditing Standards requires the auditor to perform limited procedures on the Pinelands Commission’s response to the findings identified in our audit and described in the accompanying schedule of findings and responses. The Pinelands Commission’s response to the findings identified in our audit are described in the accompanying schedule of findings and responses. The Pinelands Commission’s response was not subjected to the auditing procedures applied in the audit of the financial statements and, accordingly, we express no opinion on the response.

Purpose of this Report

The purpose of this report is solely to describe the scope of our testing of internal control and compliance and the results of that testing, and not to provide an opinion on the effectiveness of the entity's internal control or on compliance. This report is an integral part of an audit performed in accordance with *Government Auditing Standards* in considering the entity's internal control and compliance. Accordingly, this communication is not suitable for any other purpose.



David J. Kaschak
State Auditor
March 3, 2026

**PINELANDS COMMISSION
SCHEDULE OF AUDIT FINDINGS AND RESPONSES
FOR THE YEAR ENDED JUNE 30, 2022**

Finding 2022-001

Material Weakness – Internal Controls over Financial Reporting

The Pinelands Commission’s financial statement preparation process failed to provide reliable financial statements presented for audit. The Pinelands Protection Act of 1979 section 13:18A-19 requires the Commission to provide annual audited financial statements to the Governor, the Legislature, and to the Secretary of the United States Department of the Interior. The Pinelands Commission Accounting/Financial Control Procedure Manual details the internal control processes that should be followed to produce complete and accurate annual financial statements. The Commission retains an accounting firm to assist in the financial statement preparation process.

We found the Commission did not accurately record all transactions to the financial statements, and the trial balance provided to us was out of balance by \$15,353. Additionally, there were 15 audit adjustments totaling \$2.7 million, and the financial statements were revised to reflect these entries.

We recommend the Commission implement internal controls to ensure all transactions are recorded properly in accordance with the established policy.

Response: 2022-001

Please see page 60

Finding 2022-002

Significant Deficiency – Information Technology (IT) – Lack of Formal Policies and Segregation of Duties

The New Jersey *Statewide Information Security Manual (SISM)* requires agencies to maintain effective controls over user access to information assets and implement a formal process to review user access at least every six months. Generally, the review should specifically identify and revoke access for those User IDs no longer needed. The Commission has procedures in place but does not currently have a formal policy to document new employees or revoke access for terminated users or for users who no longer require system access. The lack of formal policy weakens the internal control environment and may lead to unauthorized access to systems, data leaks, system breaches, and possible business interruptions.

The *SISM* states accounts that have been inactive for over 90 days shall be disabled. We tested all 20 active user accounts in the accounting system as October 22, 2024. Of these, two users had not accessed the system for over a year. Therefore, their access should have been disabled.

The Commission does not have a formal risk assessment. While the IT department is aware of potential risks and validates those risks during periodic disaster recovery tests, this process is

not formally documented. The *SISM* requires agencies to implement continuous risk management processes that account for the identification, assessment, treatment, and monitoring of risks that can adversely impact their operations, information systems, and information. Without a documented risk assessment, systems are more vulnerable to unidentified or unmitigated threats.

The Commission has not implemented a formal security plan for its application systems. The *SISM* defines a security plan as a formal document that provides an overview of the security and privacy requirements for an information system and describes the controls in place or planned for meeting those requirements. Although security controls are present, they are undocumented, and the absence of a formal plan limits preparedness and risks unauthorized access to its system.

The *SISM* states system access authorizations need to be defined to support segregation of duties and prevent malevolent activity without collusion. Segregation of duties need to be in place to ensure one employee does not have the ability to provide full access to the accounting system. We found the Commission's business manager has the ability to assign all users' access and privileges while also having the ability to perform all functions of the accounting system. This "super user" functionality creates a risk of transactions being processed without proper segregation of duties.

We recommend the Commission implement a formal policy on user access and removal that includes the periodic review and removal of inactive employees. A formal risk assessment and a formal security plan should be created. To ensure proper segregation of duties, the "super user" function should be removed from the Business Manager and reassigned to the IT department, where the IT manager already has equivalent access.

Response: 2022-002

Please see page 60

Pinelands Commission

**Report on Compliance for Each Major State Program; Report on
Internal Control over Compliance; and Report on the Schedule of
Expenditures of State Financial Assistance Required by New Jersey Department of the
Treasury Circular No. 15-08-OMB**

For the Fiscal Year Ended June 30, 2022

SENATE

Anthony M. Bucco
Kristin M. Corrado
Linda R. Greenstein
Joseph Pennacchio
M. Teresa Ruiz
Nicholas P. Scutari
Robert W. Singer
Shirley K. Turner

GENERAL ASSEMBLY

Craig J. Coughlin
Christopher P. DePhillips
John DiMaio
Louis D. Greenwald
Antwan L. McClellan
Nancy F. Muñoz
Verlina Reynolds-Jackson
Shanique Speight



NEW JERSEY LEGISLATURE
OFFICE OF LEGISLATIVE SERVICES

125 SOUTH WARREN STREET • P.O. BOX 067 • TRENTON, NJ 08625-0067
www.njleg.gov

David J. Kaschak
State Auditor

Brian M. Klingele
Assistant State Auditor

Robert F. Gatti
Assistant State Auditor

**REPORT ON COMPLIANCE FOR EACH MAJOR STATE PROGRAM; REPORT ON
INTERNAL CONTROL OVER COMPLIANCE; AND REPORT ON THE SCHEDULE
OF EXPENDITURES OF STATE FINANCIAL ASSISTANCE REQUIRED BY NEW
JERSEY DEPARTMENT OF THE TREASURY CIRCULAR No. 15-08-OMB**

INDEPENDENT AUDITOR'S REPORT

The Honorable Mikie Sherrill
Governor of New Jersey

The Honorable Nicholas P. Scutari
President of the Senate

The Honorable Craig J. Coughlin
Speaker of the General Assembly

Ms. Maureen McMahon
Executive Director
Office of Legislative Services

Report on Compliance for Each Major State Program

Opinion on Each Major State Program

We have audited the Pinelands Commission's compliance with the types of compliance requirements described in the New Jersey Grant Compliance Supplement that could have a direct and material effect on each of its major state programs for the year ended June 30, 2022. The Pinelands Commission's major state programs are identified in the summary of auditor's results section of the accompanying schedule of audit findings and questioned costs.

In our opinion, the Pinelands Commission complied, in all material respects, with the types of compliance requirements referred to above that could have a direct and material effect on each of its major state programs for the year ended June 30, 2022.

Basis for Opinion

We conducted our audit of compliance in accordance with auditing standards generally accepted in the United States of America; the standards applicable to financial audits contained in *Government Auditing Standards*, issued by the Comptroller General of the United States (*Government Auditing Standards*); and New Jersey Department of the Treasury Circular No. 15-08-OMB. Our responsibilities under those standards are further described in the Auditor's Responsibilities for the Audit of Compliance section of our report.

We are required to be independent of the Pinelands Commission and to meet our other ethical responsibilities, in accordance with relevant ethical requirements relating to our audit. We believe that the audit evidence we have obtained is sufficient and appropriate to provide a basis for our opinion on compliance for each major state program. Our audit does not provide a legal determination of the Pinelands Commission's compliance with compliance requirements referred to above.

Responsibilities of Management for Compliance

Management is responsible for compliance with the requirements referred to above and for the design, implementation, and maintenance of effective internal control over compliance with the requirements of laws, statutes, regulations, rules, and provisions of contracts or grant agreements applicable to the state programs.

Auditor's Responsibility for the Audit of Compliance

Our objectives are to obtain reasonable assurance about whether material noncompliance with the compliance requirements referred to above occurred, whether due to fraud or error, and to express an opinion on the Pinelands Commission's compliance based on our audit. Reasonable assurance is a high level of assurance but is not absolute assurance and therefore is not a guarantee that an audit conducted in accordance with generally accepted auditing standards, *Government Auditing Standards*, and the New Jersey Department of the Treasury Circular No. 15-08-OMB will always detect material noncompliance when it exists. The risk of not detecting material noncompliance resulting from fraud is higher than for that resulting from error, as fraud may involve collusion, forgery, intentional omissions, misrepresentations, or the override of internal control. Noncompliance with the compliance requirements referred to above is considered material, if there is a substantial likelihood that, individually or in the aggregate, it would influence the judgment made by a reasonable user of the report on compliance about the Pinelands Commission's compliance with the requirements of each major state program as a whole.

In performing an audit in accordance with generally accepted auditing standards, *Government Auditing Standards*, and Treasury Circular No. 15-08-OMB, we:

- exercise professional judgment and maintain professional skepticism throughout the audit.
- identify and assess the risks of material noncompliance, whether due to fraud or error, and design and perform audit procedures responsive to those risks. Such procedures include examining, on a test basis, evidence regarding the Pinelands Commission's compliance with the compliance requirements referred to above and performing such other procedures as we considered necessary in the circumstances.
- obtain an understanding of the Pinelands Commission's internal control over compliance relevant to the audit in order to design audit procedures that are appropriate in the circumstances and to test and report on internal control over compliance in accordance with requirements, but not for the purpose of expressing an opinion on the effectiveness of the Pinelands Commission's internal control over compliance. Accordingly, no such opinion is expressed.

We are required to communicate with those charged with governance regarding, among other matters, the planned scope and timing of the audit and any significant deficiencies and material weaknesses in internal control over compliance that we identified during the audit.

Report on Internal Control over Compliance

A deficiency in internal control over compliance exists when the design or operation of a control over compliance does not allow management or employees, in the normal course of performing their assigned functions, to prevent, or to detect and correct, noncompliance with a type of compliance requirement of a state program on a timely basis. *A material weakness in internal control over compliance* is a deficiency, or a combination of deficiencies, in internal control over compliance, such that there is a reasonable possibility that material noncompliance with a type of compliance requirement of a state program will not be prevented, or detected and corrected, on a timely basis. *A significant deficiency in internal control over compliance* is a deficiency, or a combination of deficiencies, in internal control over compliance with a type of compliance requirement of a state program that is less severe than a material weakness in internal control over compliance, yet important enough to merit attention by those charged with governance.

Our consideration of internal control over compliance was for the limited purpose described in the Auditor's Responsibilities for the Audit of Compliance section above and was not designed to identify all deficiencies in internal control over compliance that might be material weaknesses or significant deficiencies in internal control over compliance. Given these limitations, during our audit we did not identify any deficiencies in internal control over compliance that we consider to be material weaknesses, as defined above. However, material weaknesses or significant deficiencies in internal control over compliance may exist that were not identified.

Our audit was not designed for the purpose of expressing an opinion on the effectiveness of internal control over compliance. Accordingly, no such opinion is expressed.

The purpose of this report on internal control over compliance is solely to describe the scope of our testing of internal control over compliance and the results of that testing based on the requirements of the New Jersey Department of the Treasury Circular No. 15-08-OMB. Accordingly, this report is not suitable for any other purpose.

Report on the Schedule of Expenditures of State Financial Assistance Required by New Jersey Department of the Treasury Circular No. 15-08-OMB

We have audited the financial statements of the Pinelands Commission as of and for the year ended June 30, 2022, and have issued our report thereon dated March 3, 2026, which contained an unmodified opinion on those financial statements. Our audit was conducted for the purpose of forming an opinion on the financial statements as a whole. The accompanying Schedule of Expenditures of State Financial Assistance is presented for purposes of additional analysis as required by New Jersey Department of the Treasury Circular No. 15-08-OMB and is not a required part of the financial statements. Such information is the responsibility of management and was derived from and relates directly to the underlying accounting and other records used to prepare the financial statements. The information has been subjected to the auditing procedures applied in the audit of the financial statements and certain additional procedures, including comparing and reconciling such information directly to the underlying accounting and other records used to prepare the financial statements or to the financial statements themselves, and other additional procedures in accordance with auditing standards generally accepted in the United States of America. In our opinion, the Schedule of Expenditures of State Financial Assistance is fairly stated in all material respects in relation to the financial statements as a whole.



David J. Kaschak
State Auditor
March 3, 2026

**PINELANDS COMMISSION
SUMMARY SCHEDULE OF AUDIT FINDINGS AND QUESTIONED COSTS
FISCAL YEAR ENDED JUNE 30, 2022**

Section I - Summary of Auditor's Results

Financial Statements

Type of auditor's report issued: Unmodified

Internal control over financial reporting:

Material weakness(es) identified? Yes No

Significant deficiency(ies) identified? Yes None Reported

Noncompliance material to financial statements noted? Yes No

Federal Awards Section

Federal Awards Section is not applicable; The Pinelands Commission did not meet the \$750,000 threshold for federal single audit.

State Awards Section

Internal control over major programs:

Material weakness(es) identified? Yes No

Significant deficiency(ies) identified? Yes None Reported

Type of auditor's report on compliance for major programs: Unmodified

Any audit findings disclosed that are required to be reported in accordance with New Jersey Department of the Treasury Circular No. 15-08-OMB Yes No

**PINELANDS COMMISSION
SUMMARY SCHEDULE OF FINDINGS AND QUESTIONED COSTS
FISCAL YEAR ENDED JUNE 30, 2022**

Section I - Summary of Auditor's Results (continued):

Identification of major programs:

<u>State Program Number</u>	<u>Name of State Program</u>
100-042-4800-082	State of New Jersey Appropriation
Not applicable	Credit from State - Fringe Benefits

Section II – Schedule of Financial Statement Findings

Finding 2022-001

Material Weakness – Internal Controls over Financial Reporting

The Pinelands Commission's financial statement preparation process failed to provide reliable financial statements presented for audit. The Pinelands Protection Act of 1979 section 13:18A-19 requires the Commission to provide annual audited financial statements to the Governor, the Legislature, and to the Secretary of the United States Department of the Interior. The Pinelands Commission Accounting/Financial Control Procedure Manual details the internal control processes that should be followed to produce complete and accurate annual financial statements. The Commission retains an accounting firm to assist in the financial statement preparation process.

We found the Commission did not accurately record all transactions to the financial statements, and the trial balance provided to us was out of balance by \$15,353. Additionally, there were 15 audit adjustments totaling \$2.7 million, and the financial statements were revised to reflect these entries.

We recommend the Commission implement internal controls to ensure all transactions are recorded properly in accordance with the established policy.

Response: 2022-001

Please see page 60

Finding 2022-002

Significant Deficiency – Information Technology (IT) – Lack of Formal Policies and Segregation of Duties

The New Jersey *Statewide Information Security Manual (SISM)* requires agencies to maintain effective controls over user access to information assets and implement a formal process to review user access at least every six months. Generally, the review should specifically identify

and revoke access for those User IDs no longer needed. The Commission has procedures in place but does not currently have a formal policy to document new employees or revoke access for terminated users or for users who no longer require system access. The lack of formal policy weakens the internal control environment and may lead to unauthorized access to systems, data leaks, system breaches, and possible business interruptions.

The *SISM* states accounts that have been inactive for over 90 days shall be disabled. We tested all 20 active user accounts in the accounting system as October 22, 2024. Of these, two users had not accessed the system for over a year. Therefore, their access should have been disabled.

The Commission does not have a formal risk assessment. While the IT department is aware of potential risks and validates those risks during periodic disaster recovery tests, this process is not formally documented. The *SISM* requires agencies to implement continuous risk management processes that account for the identification, assessment, treatment, and monitoring of risks that can adversely impact their operations, information systems, and information. Without a documented risk assessment, systems are more vulnerable to unidentified or unmitigated threats.

The Commission has not implemented a formal security plan for its application systems. The *SISM* defines a security plan as a formal document that provides an overview of the security and privacy requirements for an information system and describes the controls in place or planned for meeting those requirements. Although security controls are present, they are undocumented, and the absence of a formal plan limits preparedness and risks unauthorized access to its system.

The *SISM* states system access authorizations need to be defined to support segregation of duties and prevent malevolent activity without collusion. Segregation of duties need to be in place to ensure one employee does not have the ability to provide full access to the accounting system. We found the Commission's business manager has the ability to assign all users' access and privileges while also having the ability to perform all functions of the accounting system. This "super user" functionality creates a risk of transactions being processed without proper segregation of duties.

We recommend the Commission implement a formal policy on user access and removal that includes the periodic review and removal of inactive employees. A formal risk assessment and a formal security plan should be created. To ensure proper segregation of duties, the "super user" function should be removed from the Business Manager and reassigned to the IT department, where the IT manager already has equivalent access.

Response: 2022-002

Please see page 60

Section III – Schedule of State Awards Findings and Questioned Costs

The audit disclosed no findings or questioned costs for the current period.

PINELANDS COMMISSION
SUMMARY SCHEDULE OF PRIOR AUDIT FINDINGS AND QUESTIONED COSTS
FISCAL YEAR ENDED JUNE 30, 2022

<u>Finding No.</u>	<u>Condition</u>	<u>Status</u>
None.		



State of New Jersey
 THE PINELANDS COMMISSION
 PO Box 359
 NEW LISBON, NJ 08064
 (609) 894-7300
 www.nj.gov/pinelands



MIKIE SHERRILL
 Governor
 DR. DALE G. CALDWELL
 Lt. Governor

General Information: Info@pinelands.nj.gov
 Application Specific Information: AppInfo@pinelands.nj.gov

LAURA E. MATOS
 Chair
 SUSAN R. GROGAN
 Executive Director

February 25, 2026

Robert F. Gatti
 Assistant State Auditor
 125 South Warren St.
 P.O. Box 067
 Trenton, NJ 08625-0067

Dear Mr. Gatti:

Thank you for providing us with a confidential draft copy of the Pinelands Commission's FY2022 audit report. As directed, we transmitted our written comments to your office via email on February 20, 2026. We are now resubmitting them in the requested format.

The FY2022 draft audit report includes two findings, one dealing with internal controls over Financial Reporting and the second related to a lack of formal Commission policies and segregation of duties with regard to the Edmunds Accounting System. Please see our attached response. The Commission will be seeking a new Accounting Firm to address the Financial Reporting internal controls. Our Management Information Systems (MIS) staff have already begun the segregation of duties in the Edmunds Accounting System mentioned in finding 2022-002. The MIS Manager will prepare a formal written Risk Assessment and Security Plan for the Edmunds Accounting Software.

These issues will be resolved prior to commencement of the Commission's FY 2023 Audit.

Sincerely,

Susan R. Grogan, P.P., AICP
 Executive Director

Enclosure

c: Jessica Lynch, Business Manager
 Alan Avery, Vice-Chair, Pinelands Commission
 Laura E. Matos, Chair, Pinelands Commission

Pinelands Commission
Corrective Actions for the FY 2022 Audit Findings

Finding 2022-001

Material Weakness – Internal Controls over Financial Reporting

Commission Response 2022-001

The Pinelands Commission will seek a new Accounting Firm to prepare the Financial Statements and companion documentation for the FY 2023 Audit. The new Accountant will also review the Commission’s transactions regarding General Ledger, Accounts Payable, Payroll, Fixed Assets and Compensated Absences for audit readiness. All parties will need to gain a working knowledge of the Revenue and Expense controls and how they affect the Accounts Payable module and Financial Statements. An RFP is expected to be posted by March 31, 2026.

The Pinelands Commission is currently recruiting for a new Business Services Assistant. This individual will be assigned a variety of tasks, including day-to-day bookkeeping responsibilities. This will allow the Business Manager to devote more time to significant financial matters, including future audits, and will facilitate additional segregation of duties in the Business Office. The hiring process is expected to be completed by May.

Finding 2022-002

Significant Deficiency – Information Technology (IT) – Lack of Formal Policies and Segregation of Duties

Commission Response 2022-002

The Commission has reviewed the New Jersey Statewide Information Security Manual (SISM), effective February 6, 2024.

The Commission has identified and disabled all inactive user accounts in the Edmunds Accounting System as of February 17, 2026. Formal written policies for the regular review of user access, including documentation of new employees and revocation of access for terminated or inactive users, will be prepared prior to commencement of the FY23 audit.

The Commission will prepare a formal written Risk Assessment and formal written Security Plan for the Edmunds Accounting Software prior to commencement of the FY23 audit. The Business Manager’s “super user” function was removed on February 17, 2026, and reassigned to the Manager of Information Systems, thereby ensuring appropriate segregation of duties for purposes of the Edmunds Accounting System.



RESOLUTION OF THE NEW JERSEY PINELANDS COMMISSION

NO. PC4-26- 09

TITLE: To Authorize the Executive Director to Enter into a Contract for Construction Services for the Historic Fenwick Manor Rehabilitation Project

Commissioner Lohbauer moves and Commissioner Rittler Sanchez seconds the motion that:

WHEREAS, in 1990, the Pinelands Commission adopted Resolution PC4-90-05, designating Fenwick Manor as a Cultural Resource of Significance to the History of the Pinelands; and

WHEREAS, on October 25, 1990, Fenwick Manor was entered into the National Register of Historic Places; and

WHEREAS, on March 11, 2022, the Pinelands Commission adopted Resolution PC4-22-13, authorizing the Acting Executive Director to submit an application to the New Jersey Historic Trust for a 2022 Preserve New Jersey Historic Preservation Fund Historic Sites Management Grant to fund the preparation of a Preservation Plan for historic Fenwick Manor; and

WHEREAS, on September 28, 2022, the New Jersey Historic Trust announced that grant funding in the amount of \$31,387 had been awarded to the Pinelands Commission for preparation of a Preservation Plan for Fenwick Manor; and

WHEREAS, on October 14, 2022, the Pinelands Commission adopted Resolution PC4-22-41, accepting the \$31,387 grant from the New Jersey Historic Trust and authorizing the Acting Executive Director to enter into a contract with the firm of Connolly & Hickey Historical Architects to complete the Preservation Plan; and

WHEREAS, the completed Preservation Plan details the interior and exterior rehabilitation work that is necessary to ensure the long-term preservation of Fenwick Manor and the safety of the Commission's employees; and

WHEREAS, on April 14, 2023, the Pinelands Commission adopted Resolution PC4-23-15, authorizing the Executive Director to submit an application to the New Jersey Historic Trust for a 2023 Preserve New Jersey Historic Preservation Fund Capital Level II Grant to fund the rehabilitation efforts outlined in the Preservation Plan for historic Fenwick Manor; and

WHEREAS, on September 28, 2023, the New Jersey Historic Trust announced that Capital II grant funding in the amount of \$575,000 had been awarded to the Pinelands Commission for rehabilitation of historic Fenwick Manor; and

WHEREAS, on February 9, 2024, the Pinelands Commission adopted Resolution PC4-24-03, accepting the \$575,000 grant and authorizing the Executive Director to execute a grant agreement with the New Jersey Historic Trust; and

WHEREAS, as authorized by Resolution PC4-25-10, the Pinelands Commission entered into a contract with Connolly & Hickey Historical Architects, LLC in May 2025 to provide professional design and project management services for the rehabilitation of Fenwick Manor; and

WHEREAS, on September 15, 2025, the New Jersey Historic Trust pre-qualified four historic restoration general contractors with the necessary experience to complete the Fenwick Manor rehabilitation project; and

WHEREAS, a Request for Proposals (RFP) to procure construction services to complete the rehabilitation of historic Fenwick Manor was distributed to all pre-qualified contractors on February 12, 2026; and

WHEREAS, on February 19 and 24, 2026, the Commission hosted site visits for prospective contractors to tour historic Fenwick Manor; and

WHEREAS, the Commission received two proposals prior to the deadline of 2:00 p.m. on March 10, 2026; and

WHEREAS, a three-member Evaluation Committee composed of Pinelands Commission staff and Connolly & Hickey Historical Architects individually scored each proposal based on the criteria established in the RFP; and

WHEREAS, based on the Evaluation Committee’s individual scores of each proposal, the Committee recommended that the contract be awarded to Hawley Bros Inc. of Chesterfield, NJ, in the amount of \$954,320; and

WHEREAS, the Executive Director and the Commission’s Personnel & Budget Committee concurred with the Evaluation Committee’s recommendation; and

WHEREAS, the Pinelands Commission’s adopted FY2026 Fenwick Manor Preservation Budget contains sufficient funding for the project, including the \$575,000 Capital Grant, special state appropriations of \$500,000 in FY2023 and \$69,000 in FY2026, and \$120,000 from the Commission’s own Fenwick Manor reserve account; and

WHEREAS, pursuant to N.J.S.A. 13:18A-5h, no action authorized by the Commission shall have force or effect until ten (10) days, Saturdays, Sundays and public holidays excepted, after a copy of the minutes of the meeting of the Commission has been delivered to the Governor for review, unless prior to expiration of the review period the Governor shall approve same, in which case the action shall become effective upon such approval.

NOW, THEREFORE BE IT RESOLVED that the Executive Director is authorized to enter into a contract with Hawley Bros Inc. of Chesterfield, NJ in the amount of \$954,320 to complete all the necessary work to rehabilitate historic Fenwick Manor.

Record of Commission Votes

	AYE	NAY	NP	A/R*		AYE	NAY	NP	A/R*		AYE	NAY	NP	A/R*
Asselta	X				Lohbauer	X				Rittler Sanchez	X			
Avery	X				Matro	X				Signor	X			
Buzby-Cope	X				Mauriello	X				Wallner	X			
Irick	X				Meade	X				Matos			X	
Lettman			X		Pikolycky	X								

*A = Abstained / R = Recused

Adopted at a meeting of the Pinelands Commission

Date: April 10, 2026



Susan R. Grogan
Executive Director



Alan W. Avery, Jr.
Vice Chair

BID FORM - STIPULATED SUM (SINGLE-PRIME CONTRACT)

Restoration

Fenwick Manor
New Lisbon (Pemberton Twp.), Burlington County, NJ
Architect's Project No.: 2435C

DOCUMENT 004113 - BID FORM - STIPULATED SUM (SINGLE-PRIME CONTRACT) (REVISED JULY 7, 2025)

1.1 BID INFORMATION

Bidder: Hawley Bros Inc

Project Name: Restoration and Structural Upgrades at the Fenwick Manor

Project Location: 15 Springfield Road, New Lisbon, Burlington County, NJ 08064

Project Manager: New Jersey Pinelands Commission

Architect: Connolly & Hickey Historical Architects, LLC

Architect Project Number: 2435C

1.2 CERTIFICATIONS AND BASE BID

Base Bid, Single-Prime (All Trades) Contract: The undersigned Bidder, having carefully examined the Procurement and Contracting Requirements, Conditions of the Contract, Drawings, Specifications, and all subsequent Addenda, as prepared by Connolly & Hickey Historical Architects, LLC and Architect's consultants, having visited the site, and being familiar with all conditions and requirements of the Work, hereby agrees to furnish all material, labor, equipment and services, including all scheduled allowances, necessary to complete the construction of the above-named project, according to the requirements of the Procurement and Contracting Documents, for the stipulated sum of:

Bidder: Hawley Bros Inc

A. BASE BID		
1.	GENERAL REQUIREMENTS	\$ 69,200.00
2.	TEMPORARY FACILITIES	\$ 6,400.00
3.	DIVISION 2 – EXISTING CONDITIONS	\$ 16,732.00
4.	DIVISION 3 - CONCRETE	\$ 90,902.00
5.	DIVISION 4 - MASONRY	\$ 78,900.00
6.	DIVISION 5 - METALS	\$ 7,800.00
7.	DIVISION 6 – WOODS AND PLASTICS	\$ 113,806.00
8.	DIVISION 7 - THERMAL AND MOISTURE PROTECTION	\$ 158,650.00

BID FORM - STIPULATED SUM (SINGLE-PRIME CONTRACT)

Restoration

Fenwick Manor
 New Lisbon (Pemberton Twp.), Burlington County, NJ
 Architect's Project No.: 2435C

9.	DIVISION 8 – DOORS AND WINDOWS	\$ 79,950.00
10.	DIVISION 9 – FINISHES	\$ 213,040.00
11.	DIVISION 10 – SPECIALTIES (Signs)	\$ 3,680.00
12.	DIVISION 23 – HEATING, VENTILATING, AND AIR CONDITIONING (HVAC) (Ductwork Adjustments)	\$ 33,985.00
15.	DIVISION 32 – EXTERIOR IMPROVEMENTS (Drainage)	\$ 56,275.00
16.	GENERAL CONTINGENCY ALLOWANCE	\$ 15,000.00
18.	ALLOWANCES PER DRAWINGS	\$ 10,000.00
BASE BID:		\$ 954,320.00
<i>(In writing)</i>		<i>(In Dollars)</i>

B. BID ALTERNATES		
1.	DEDUCT THE INSTALLATION OF A NEW ASPHALT SHINGLE ROOFING INCLUDING HUNG GUTTERS. BASE WORK SHALL INCLUDE THE INSTALLATION OF NEW FLASHINGS AT THE CHIMNEYS INCLUDING REPOINTING.	DEDUCT \$ <u>126,500.00</u>
2.	DEDUCT THE INSTALLATION OF UNDERGROUND DRAINAGE INCLUDING CAST IRON LEADER SLEEVES, PVC UNDERGROUND PIPING, AND NEW DRY WELLS. WORK SHALL INCLUDE INSTALLATION OF NEW BLUESTONE SPLASH BLOCKS AT EACH EXISTING LEADER OUTLET.	DEDUCT \$ <u>56,275.00</u>
C. ALLOWANCE		
1.	Contingency Allowance for Unforeseen Conditions	\$ 15,000.00
2.	ALLOW FOR 15% MORE PLASTER REPAIRS AT WALLS (NEW PLASTER ON EXISTING WOOD LATH AT WALLS) THAN SHOWN ON DRAWINGS.	
		\$ 3,500.00

BID FORM - STIPULATED SUM (SINGLE-PRIME CONTRACT)

Restoration

Fenwick Manor
 New Lisbon (Pemberton Twp.), Burlington County, NJ
 Architect's Project No.: 2435C

3.	ALLOW FOR 25 LF OF ADDITIONAL CRACK REPAIRS AT INTERIOR WALL FINISHES.	
		\$ 1,850.00
4.	ALLOW FOR 50 SF OF ADDITIONAL WOOD FLOORING REPLACEMENT (MAPLE, 3" X 1" THICK) INCLUDING STAIN TO MATCH EXISTING AND 3-COAT ALKYD-BASED POLYURETHANE).	
		\$ 1,500.00
5.	ALLOW FOR 15 L.F. OF MOLDED DUTCHMAN REPAIRS (CORNICE COMPONENTS) PER EACH ELEVATION.	
		\$ 6,000.00
6.	ALLOW FOR 25 LF MORE REPLACEMENT IN-KIND OF CLAPBOARD SIDING. CONDITIONS VARY - FOR BIDDING USE - 7 1/2" EXPOSURE, 5/4-INCH THICK WITH 10" TALL (WIDTH) CLAPBOARD SIDING, WITH MOLDED EDGE.	
		\$ 1,250.00
7.	ALLOW FOR 50 LF OF CRACK REPAIR AT FLAT-STOCK WOOD OR CLAPBOARD SIDING PER EACH ELEVATION.	
		\$ 6,300.00

D. UNIT PRICES		
A.	INTERIOR: APPLICATION OF 3-COAT REPLICATION PLASTER TO ALIGN WITH EXISTING PLASTER (+/- 1 INCH THICK)	
	(FOR ADD ALLOWANCE)	\$ 55.00 / SQ. FEET
B.	INTERIOR: REPAIR OF CRACKED PLASTER WITH REPLICATION PLASTER. CUT OUT EXISTING CRACK, APPLY BONDING AGENT, AND APPLY REPLICATION PLASTER.	
	(FOR ADD ALLOWANCE)	\$ 38.50 /LIN. FEET
C.	INTERIOR: 1" THICK MAPLE STRIP FLOOR (+/-3" WIDE) WITH APPLICATION OF STAIN AND 3-COAT ALKYD BASED POLYURETHANE.	
	(FOR ADD ALLOWANCE)	\$ 30.00 / SQ. FEET
D.	EXTERIOR: MOLDED CORNICE REPAIRS TO MATCH EXISTING OF SPANISH CEDAR (OR EQUAL)/6" DEEP/5/4 THICK AND LINEAR FOOT.	
		\$ 50.00 /LIN. FEET
E.	EXTERIOR: REPLACEMENT OF CLAPBOARD SIDING - 7 1/2" EXPOSURE, 5/4-INCH THICK WITH 10" TALL (WIDTH) CLAPBOARD SIDING, WITH MOLDED EDGE	

BID FORM - STIPULATED SUM (SINGLE-PRIME CONTRACT)

Restoration

Fenwick Manor
New Lisbon (Pemberton Twp.), Burlington County, NJ
Architect's Project No.: 2435C

	\$ 50.00	/Sq. Ft.
F.	EXTERIOR: WOOD CRACK REPAIR AT 5/4 INCH FLAT-STOCK WOOD OR CLAPBOARD SIDING.	
	\$ 31.50	/Lin. Feet.

1.3 SUBCONTRACTORS AND SUPPLIERS

The following companies shall execute subcontracts for the portions of the Work indicated:

- 1.4 TIME OF COMPLETION
- Aetna Roofing Corporation : Roofing ,Gutters Flashing
 - Fresh Look Painting : Painting
 - JW Poole Inc : HVAC

The undersigned Bidder proposes and agrees hereby to commence the Work of the Contract Documents on a date specified in a written Notice to Proceed to be issued by Architect and shall fully complete the Work within **150 days of the Notice to Proceed.**

1.5 ACKNOWLEDGEMENT OF ADDENDA

The undersigned Bidder acknowledges receipt of and use of the following Addenda in the preparation of this Bid:

1. Addendum No. 1, dated February 20.
2. Addendum No. 2, dated _____.
3. Addendum No. 3, dated _____.
4. Addendum No. 4, dated _____.

1.6 CONTRACTOR'S LICENSE

The undersigned further states that it is a duly licensed contractor, for the type of work proposed, in State of New Jersey, and that all fees, permits, etc., pursuant to submitting this proposal have been paid in full.

1.7 SUBMISSION OF BID

Respectfully submitted this 10 day of March, 2025. 2026

Submitted By: Hawley Bros Inc (Name of bidding firm or corporation).

Authorized Signature: Barry W Hawley (Handwritten signature).

Signed By: Barry W Hawley (Type or print name).

Title: President (Project Manager/Partner/President/Vice President).

Witness By: Elmer W Hawley (Handwritten signature).

Attest: Donna L Hawley (Handwritten signature).

By: Donna L Hawley (Type or print name).

BID FORM - STIPULATED SUM (SINGLE-PRIME CONTRACT)

Restoration

Fenwick Manor
New Lisbon (Pemberton Twp.), Burlington County, NJ
Architect's Project No.: 2435C

Title: Corporate Secretary (Corporate Secretary or Assistant Secretary).

Street Address: 192 Harrison Rd.

City, State, Zip: Chesterfield N J 08515.

Phone: 609-291-0045.

License No.: 13VH00404300.

Federal ID No.: 22-2285462 (Affix Corporate Seal Here).

END OF DOCUMENT 004113



RESOLUTION OF THE NEW JERSEY PINELANDS COMMISSION

NO. PC4-26-_____

TITLE: **Approving** With Conditions Applications for **Public Development** (Application Numbers 1986-0122.027 & 1987-0345.021)

Commissioner _____ moves and Commissioner _____
seconds the motion that:

WHEREAS, the Pinelands Commission has reviewed the Public Development Application Reports and the recommendation of the Executive Director that the following applications for Public Development be approved with conditions:

1986-0122.027

Applicant: **State of NJ Department of Human Services, New Lisbon Developmental Center**

Municipality: Woodland Township

Management Area: Pinelands Preservation Area District

Date of Report: April 14, 2026

Proposed Development: Installation of 142 linear feet of sanitary sewer main at the New Lisbon Developmental Center; and

1987-0345.021

Applicant: **Lenape Regional High School District**

Municipality: Medford Township

Management Area: Pinelands Regional Growth Area

Date of Report: April 15, 2026

Proposed Development: Paving of an approximately 30,000 square foot existing gravel parking lot .

WHEREAS, no request for a hearing before the New Jersey Office of Administrative Law regarding the Executive Director's recommendation has been received for any of these applications; and

WHEREAS, the Pinelands Commission hereby adopts the Conclusion of the Executive Director for each of the proposed developments; and

WHEREAS, the Pinelands Commission hereby determines that each of the proposed public developments conform to the standards for approving an application for public development set forth in N.J.A.C. 7:50-4.57 if the conditions recommended by the Executive Director are imposed; and

WHEREAS, pursuant to N.J.S.A. 13A-5h, no action authorized by the Commission shall have force or effect until ten (10) days, Saturdays, Sundays and public holidays excepted, after a copy of the minutes of the meeting of the Commission has been delivered to the Governor for review, unless prior to expiration of the review period the Governor shall approve same, in which case the action shall become effective upon such approval.

NOW, THEREFORE BE IT RESOLVED that Application Numbers 1986-0122.027 & 1987-0345.021 for public development are hereby **approved** subject to the conditions recommended by the Executive Director.

Record of Commission Votes

AYE NAY NP A/R*				AYE NAY NP A/R*				AYE NAY NP A/R*			
Asselta				Lohbauer				Rittler Sanchez			
Avery				Matro				Signor			
Buzby-Cope				Mauriello				Wallner			
Irick				Meade				Matos			
Lettman				Pikolycky							

*A = Abstained / R = Recused

Adopted at a meeting of the Pinelands Commission

Date: _____

Susan R. Grogan
Executive Director

Laura E. Matos
Chair



State of New Jersey

THE PINELANDS COMMISSION

PO Box 359

NEW LISBON, NJ 08064

(609) 894-7300

www.nj.gov/pinelands



MIKIE SHERRILL
Governor

DR. DALE G. CALDWELL
Lt. Governor

General Information: Info@pinelands.nj.gov
Application Specific Information: AppInfo@pinelands.nj.gov

LAURA E. MATOS
Chair

SUSAN R. GROGAN
Executive Director

April 14, 2026

Patrick Littleford
New Jersey Department of Human Services (via email)
222 South Warren Street
Trenton NJ 08625

Re: Application # 1986-0122.027
Block 601, Lot 4
Woodland Township

Dear Mr. Littleford:

The Commission staff has completed its review of this application for the installation of 142 linear feet of sanitary sewer main at the New Lisbon Developmental Center. Enclosed is a copy of a Public Development Application Report. On behalf of the Commission's Executive Director, I am recommending that the Pinelands Commission approve the application with conditions at its May 8, 2026 meeting.

Any interested party may appeal this recommendation in accordance with the appeal procedure attached to this document. If no appeal is received, the Pinelands Commission may either approve the recommendation of the Executive Director or refer the application to the New Jersey Office of Administrative Law for a hearing.

Prior to any development, the applicant shall obtain any other necessary permits and approvals.

Sincerely,

Charles M. Horner, P.P.

Director of Regulatory Programs

Enc: Appeal Procedure

c: Secretary, Woodland Township Planning Board (via email)
Woodland Township Construction Code Official (via email)
Secretary, Burlington County Planning Board (via email)
Joseph Gray, PE, CME (via email)



State of New Jersey

THE PINELANDS COMMISSION

PO Box 359

NEW LISBON, NJ 08064

(609) 894-7300

www.nj.gov/pinelands



MIKIE SHERRILL
Governor

DR. DALE G. CALDWELL
Lt. Governor

General Information: Info@pinelands.nj.gov
Application Specific Information: AppInfo@pinelands.nj.gov

LAURA E. MATOS
Chair

SUSAN R. GROGAN
Executive Director

PUBLIC DEVELOPMENT APPLICATION REPORT

April 14, 2026

Patrick Littleford
New Jersey Department of Human Services (via email)
222 South Warren Street
Trenton NJ 08625

Application No.: 1986-0122.027
Block 601, Lot 4
Woodland Township

This application proposes the installation of 142 linear feet of sanitary sewer main at the New Lisbon Developmental Center located on the above referenced 44.81 acre parcel in Woodland Township.

The proposed sanitary sewer main will connect two existing potable water backwash tanks to an existing sanitary sewer main. The two existing potable water backwash tanks are located at the New Lisbon Developmental Center potable water treatment plant. The proposed sanitary sewer main will allow the applicant to drain the two existing potable water backwash tanks for maintenance purposes.

STANDARDS

The Commission staff has reviewed the proposed development for consistency with all standards of the Pinelands Comprehensive Management Plan (CMP). The following reviews the CMP standards that are relevant to this application:

Land Use (N.J.A.C. 7:50-5.2(b))

The above referenced parcel is located in the Pinelands Preservation Area District. The New Lisbon Developmental Center is a nonconforming use that existed prior to the 1981 adoption of the Pinelands Comprehensive Management Plan. The proposed 142 linear feet of sanitary sewer main is permitted as accessory development to the existing potable water treatment plant.

Vegetation Management Standards (N.J.A.C. 7:50-6.23 & 6.26)

The proposed development will be located within existing maintained lawn areas. The proposed soil disturbance is limited to that which is necessary to accommodate the proposed development.

The Landscaping and Revegetation guidelines of the CMP recommend the use of grasses that are tolerant of droughty, nutrient poor conditions. To stabilize disturbed areas, the applicant proposes to

utilize grasses that meet that recommendation.

PUBLIC COMMENT

The CMP defines the proposed development as “minor” development. The CMP does not require public notice for minor public development applications. The application was designated as complete on the Commission’s website on March 17, 2026. The Commission’s public comment period closed on April 10, 2026. No public comment was submitted to the Commission regarding this application.

CONDITIONS

1. Except as modified by the below conditions, the proposed development shall adhere to the plan prepared by CME Associates and dated February 27, 2026.
2. Disposal of any construction debris or excess fill may only occur at an appropriately licensed facility.
3. Any proposed revegetation shall adhere to the "Vegetation" standards of the CMP. Where appropriate, the applicant is encouraged to utilize the following Pinelands native grasses for revegetation: Switch grass, Little bluestem and Broom-sedge.
4. Prior to any development, the applicant shall obtain any other necessary permits and approvals.

CONCLUSION

As the proposed development conforms to the standards set forth in N.J.A.C. 7:50-4.57, it is recommended that the Pinelands Commission **APPROVE** the proposed development subject to the above conditions.



State of New Jersey

THE PINELANDS COMMISSION

PO Box 359

NEW LISBON, NJ 08064

(609) 894-7300

www.nj.gov/pinelands



MIKIE SHERRILL
Governor

DR. DALE G. CALDWELL
Lt. Governor

General Information: Info@pinelands.nj.gov
Application Specific Information: AppInfo@pinelands.nj.gov

LAURA E. MATOS
Chair

SUSAN R. GROGAN
Executive Director

PINELANDS COMMISSION **APPEAL PROCEDURE**

The Pinelands Comprehensive Management Plan (N.J.A.C. 7:50-4.91) provides an interested party the right to appeal any determination made by the Executive Director to the Commission in accordance with N.J.A.C. 7:50-4.91. An interested party is someone who has a specific property interest sufficient to require a hearing on constitutional or statutory grounds. Only appeal requests submitted by someone meeting the definition of an interested party will be transmitted to the New Jersey Office of Administrative Law for a hearing. Any such appeal must be made in writing to the Commission and received by the Commission's office no later than 5:00 PM on May 4, 2026 and include the following information:

1. the name and address of the person requesting the appeal;
2. the application number;
3. the date on which the determination to be appealed was made;
4. a brief statement of the basis for the appeal; and
5. a certificate of service (a notarized statement) indicating that service of the notice has been made, by certified mail, on the clerk of the county, municipal planning board and environmental commission with jurisdiction over the property which is subject of this decision.

Within 15 days following receipt of a notice of valid appeal, the Executive Director shall initiate the procedures for assignment of an Administrative Law Judge to preside at the hearing pursuant to the Administrative Procedures Act, N.J.S.A. 52:14B-1 et seq., and the procedures established by the Office of Administrative Law. The time, date and location of such hearing shall be designated by the Office of Administrative Law.



State of New Jersey
THE PINELANDS COMMISSION
PO Box 359
NEW LISBON, NJ 08064
(609) 894-7300
www.nj.gov/pinelands



MIKIE SHERRILL
Governor
DR. DALE G. CALDWELL
Lt. Governor

General Information: Info@pinelands.nj.gov
Application Specific Information: AppInfo@pinelands.nj.gov

LAURA E. MATOS
Chair
SUSAN R. GROGAN
Executive Director

April 15, 2026

Kara Huber, Business Administrator (via email)
Lenape Regional High School District
93 Willow Grove Road
Shamong NJ 08088

Re: Application # 1987-0345.021
Block 4704, Lot 3
Medford Township

Dear Ms. Huber:

The Commission staff has completed its review of this application for the paving of an approximately 30,000 square foot existing gravel parking lot. Enclosed is a copy of a Public Development Application Report. On behalf of the Commission's Executive Director, I am recommending that the Pinelands Commission approve the application with conditions at its May 8, 2026 meeting.

Any interested party may appeal this recommendation in accordance with the appeal procedure attached to this document. If no appeal is received, the Pinelands Commission may either approve the recommendation of the Executive Director or refer the application to the New Jersey Office of Administrative Law for a hearing.

Prior to any development, the applicant shall obtain any other necessary permits and approvals.

Sincerely,

Charles M. Horner, P.P.
Director of Regulatory Programs

Enc: Appeal Procedure

c: Secretary, Medford Township Planning Board (via email)
Medford Township Construction Code Official (via email)
Medford Township Environmental Commission (via email)
Secretary, Burlington County Planning Board (via email)
Joseph Gray, PE (via email)



State of New Jersey

THE PINELANDS COMMISSION

PO Box 359

NEW LISBON, NJ 08064

(609) 894-7300

www.nj.gov/pinelands



MIKIE SHERRILL
Governor

DR. DALE G. CALDWELL
Lt. Governor

General Information: Info@pinelands.nj.gov
Application Specific Information: AppInfo@pinelands.nj.gov

LAURA E. MATOS
Chair

SUSAN R. GROGAN
Executive Director

PUBLIC DEVELOPMENT APPLICATION REPORT

April 15, 2026

Kara Huber, Business Administrator (via email)
Lenape Regional High School District
93 Willow Grove Road
Shamong NJ 08088

Application No.: 1987-0345.021
Block 4704, Lot 3
Medford Township

This application proposes the paving of an approximately 30,000 square foot existing gravel parking lot at Shawnee High School located on the above referenced 100.6 acre parcel in Medford Township.

The application also includes the removal of existing asphalt and concrete surfaces adjacent to an entrance to the school building and the stadium. The application proposes the installation of new concrete surfaces and sidewalks in these two areas. The proposed development will result in a decrease of impervious surfaces on the parcel of 17,990 square feet.

STANDARDS

The Commission staff has reviewed the proposed development for consistency with all standards of the Pinelands Comprehensive Management Plan (CMP). The following reviews the CMP standards that are relevant to this application:

Land Use (N.J.A.C. 7:50-5.28)

The parcel is located in a Pinelands Regional Growth Area. The proposed development is permitted in a Pinelands Regional Growth Area.

Wetlands Standards (N.J.A.C. 7:50-6.6)

There are wetlands located on the above referenced parcel. All development, including land disturbance, will be located at least 300 feet from wetlands. The proposed development is consistent with CMP wetland protection standards.

Vegetation Management Standards (N.J.A.C. 7:50-6.23 & 6.26)

The proposed development will be located within the limits of the existing impervious surfaces,

graveled areas and maintained grass areas. The proposed soil disturbance is limited to that which is necessary to accommodate the proposed development. The proposed development is consistent with CMP vegetation management standards.

Stormwater Management Standards (N.J.A.C. 7:50-6.84(a)6)

The proposed development will result in a decrease of impervious surfaces by 17,990 square feet. There will be no increase in the volume and rate of stormwater runoff after the proposed development than that which occurred prior to the proposed development. The proposed development is consistent with CMP stormwater management standards.

Cultural Resource Standards (N.J.A.C. 7:50-6.151)

The Commission staff reviewed available information to determine the potential for any significant cultural resources that could be affected by the proposed development. Based upon the lack of potential for significant cultural resources within the area to be developed, a cultural resource survey was not required.

PUBLIC COMMENT

The applicant has provided the requisite public notices. Notice to required land owners within 200 feet of the above referenced parcel was completed on February 4, 2026. Newspaper public notice was completed on February 9, 2026. The application was designated as complete on the Commission's website on March 18, 2026. The Commission's public comment period closed on April 10, 2026. No public comment was submitted to the Commission regarding this application.

CONDITIONS

1. Except as modified by the below conditions, the proposed development shall adhere to the plan, consisting of nine sheets, prepared by CME Associates, all sheets dated November 17, 2025 and last revised February 2, 2026.
2. Disposal of any construction debris or excess fill may only occur at an appropriately licensed facility.
3. Any proposed revegetation shall adhere to the "Vegetation" standards of the CMP. Where appropriate, the applicant is encouraged to utilize the following Pinelands native grasses for revegetation: Switch grass, Little bluestem and Broom-sedge.
4. Prior to any development, the applicant shall obtain any other necessary permits and approvals.
5. All development, including clearing and land disturbance, shall be located at least 300 feet from wetlands.

CONCLUSION

As the proposed development conforms to the standards set forth in N.J.A.C. 7:50-4.57, it is recommended that the Pinelands Commission **APPROVE** the proposed development subject to the above conditions.



State of New Jersey

THE PINELANDS COMMISSION

PO Box 359

NEW LISBON, NJ 08064

(609) 894-7300

www.nj.gov/pinelands



MIKIE SHERRILL
Governor

DR. DALE G. CALDWELL
Lt. Governor

General Information: Info@pinelands.nj.gov
Application Specific Information: AppInfo@pinelands.nj.gov

LAURA E. MATOS
Chair

SUSAN R. GROGAN
Executive Director

PINELANDS COMMISSION **APPEAL PROCEDURE**

The Pinelands Comprehensive Management Plan (N.J.A.C. 7:50-4.91) provides an interested party the right to appeal any determination made by the Executive Director to the Commission in accordance with N.J.A.C. 7:50-4.91. An interested party is someone who has a specific property interest sufficient to require a hearing on constitutional or statutory grounds. Only appeal requests submitted by someone meeting the definition of an interested party will be transmitted to the New Jersey Office of Administrative Law for a hearing. Any such appeal must be made in writing to the Commission and received by the Commission's office no later than 5:00 PM on May 4, 2026 and include the following information:

1. the name and address of the person requesting the appeal;
2. the application number;
3. the date on which the determination to be appealed was made;
4. a brief statement of the basis for the appeal; and
5. a certificate of service (a notarized statement) indicating that service of the notice has been made, by certified mail, on the clerk of the county, municipal planning board and environmental commission with jurisdiction over the property which is subject of this decision.

Within 15 days following receipt of a notice of valid appeal, the Executive Director shall initiate the procedures for assignment of an Administrative Law Judge to preside at the hearing pursuant to the Administrative Procedures Act, N.J.S.A. 52:14B-1 et seq., and the procedures established by the Office of Administrative Law. The time, date and location of such hearing shall be designated by the Office of Administrative Law.



RESOLUTION OF THE NEW JERSEY PINELANDS COMMISSION

NO. PC4-26-_____

TITLE: Issuing an Order to Certify Monroe Township's 2025 Housing Element and Fair Share Plan and Ordinance O:06-2026, adopting the Hightop Redevelopment Plan

Commissioner _____ moves and Commissioner _____ seconds the motion that:

WHEREAS, on September 9, 1983, the Pinelands Commission fully certified the Master Plan and Land Use Ordinances of Monroe Township; and

WHEREAS, Resolution #PC4-83-76 of the Pinelands Commission specified that any amendment to the Township's certified Master Plan and Land Use Ordinances be submitted to the Executive Director in accordance with N.J.A.C. 7:50-3.45 (Submission and Review of Amendments to Certified Master Plans and Land Use Ordinances) of the Comprehensive Management Plan to determine if said amendment raises a substantial issue with respect to conformance with the Pinelands Comprehensive Management Plan; and

WHEREAS, Resolution #PC4-83-76 further specified that any such amendment shall only become effective as provided in N.J.A.C. 7:50-3.45 of the Comprehensive Management Plan; and

WHEREAS, on June 25, 2025, the Monroe Township Planning Board adopted Resolution PB-22-25, approving the Township's 2025 Housing Element and Fair Share Plan, dated June 12, 2025; and

WHEREAS, the Pinelands Commission received a certified copy of Planning Board Resolution PB-22-25 and the 2025 Housing Element and Fair Share Plan on July 7, 2025; and

WHEREAS, by letter dated August 1, 2025, the Executive Director notified Monroe Township that, in accordance with N.J.A.C. 7:50-3.32, the 2025 Housing Element and Fair Share Plan was deemed incomplete until the necessary implementing ordinances were adopted and submitted to the Commission for certification; and

WHEREAS, on February 11, 2026, Monroe Township adopted Ordinance O:06-2026, approving a redevelopment plan for the Hightop Redevelopment Area, for the purpose of implementing the 2025 Housing Element and Fair Share Plan; and

WHEREAS, the Pinelands Commission received a certified copy of Ordinance O:06-2026 on March 5, 2026; and

WHEREAS, by letter dated March 23, 2026, the Executive Director notified the Township that the 2025 Housing Element and Fair Share Plan and Ordinance O:06-2026 require formal review and approval by the Pinelands Commission; and

WHEREAS, a public hearing to receive testimony on the 2025 Housing Element and Fair Share Plan and Ordinance O:06-2026 was duly advertised, noticed, and held remotely on April 8, 2026 at 9:30 a.m., with live broadcasting on the Pinelands Commission's public YouTube channel and an opportunity for the public to call-in during the broadcast; and

WHEREAS, the Executive Director has found that the 2025 Housing Element and Fair Share Plan and Ordinance O:06-2026 are consistent with the standards and provisions of the Pinelands Comprehensive Management Plan; and

WHEREAS, the Executive Director has submitted a report to the Commission recommending issuance of an order to certify that Monroe Township's 2025 Housing Element and Fair Share Plan and Ordinance O:06-2026 are in conformance with the Pinelands Comprehensive Management Plan; and

WHEREAS, the Commission’s CMP Policy and Implementation Committee has reviewed the Executive Director’s report and has recommended that the 2025 Housing Element and Fair Share Plan and Ordinance O:06-2026 be certified; and

WHEREAS, the Pinelands Commission has duly considered all public testimony submitted to the Commission concerning the 2025 Housing Element and Fair Share Plan and Ordinance O:06-2026 and has reviewed the Executive Director’s report; and

WHEREAS, the Pinelands Commission accepts the recommendation of the Executive Director; and

WHEREAS, pursuant to N.J.S.A. 13:18A-5h, no action authorized by the Commission shall have force or effect until ten (10) days, Saturdays, Sundays and public holidays excepted, after a copy of the minutes of the meeting of the Commission has been delivered to the Governor for review, unless prior to expiration of the review period the Governor shall approve same, in which case the action shall become effective upon such approval.

NOW, THEREFORE BE IT RESOLVED that

1. An Order is hereby issued to certify that Monroe Township’s 2025 Housing Element and Fair Share Plan and Ordinance O:06-2026 are in conformance with the Pinelands Comprehensive Management Plan.
2. Any additional amendments to Monroe Township’s certified Master Plan and Land Use Ordinances shall be submitted to the Executive Director in accordance with N.J.A.C. 7:50-3.45 to determine if said amendments raise a substantial issue with respect to the Comprehensive Management Plan. Any such amendment shall become effective only as provided in N.J.A.C. 7:50-3.45.

Record of Commission Votes

AYE NAY NP A/R*					AYE NAY NP A/R*					AYE NAY NP A/R*				
Asselta					Lohbauer					Rittler Sanchez				
Avery					Matro					Signor				
Buzby-Cope					Mauriello					Wallner				
Irick					Meade					Matos				
Lettman					Pikolycky									

*A = Abstained / R = Recused

Adopted at a meeting of the Pinelands Commission

Date: _____

Susan R. Grogan
Executive Director

Laura E. Matos
Chair



State of New Jersey
THE PINELANDS COMMISSION
PO Box 359
NEW LISBON, NJ 08064
(609) 894-7300
www.nj.gov/pinelands



MIKIE SHERRILL
Governor
DR. DALE G. CALDWELL
Lt. Governor

General Information: Info@pinelands.nj.gov
Application Specific Information: AppInfo@pinelands.nj.gov

LAURA E. MATOS
Chair
SUSAN R. GROGAN
Executive Director

Report on Monroe Township's 2025 Housing Element and Fair Share Plan and Ordinance O:06-2026, adopting the Hightop Redevelopment Plan

April 24, 2026

Monroe Township
125 Virginia Avenue
Williamstown, NJ 08094

Findings of Fact

I. Background

The Township of Monroe is located in the western section of the Pinelands Area in Gloucester County. Pinelands municipalities that abut Monroe Township's Pinelands Area include Franklin Township in Gloucester County, Winslow Township in Camden County and the Borough of Folsom and the Township of Buena Vista in Atlantic County.

On September 9, 1983, the Pinelands Commission fully certified the Master Plan and Comprehensive Land Management Ordinance of Monroe Township, now codified as Chapter 175 (Land Management) of the Township's Code.

On June 25, 2025, the Monroe Township Planning Board adopted Resolution PB-22-25, approving the Township's 2025 Housing Element and Fair Share Plan, dated June 12, 2025. The Pinelands Commission received a certified copy of Planning Board Resolution PB-22-25 and the Housing Element and Fair Share Plan on July 7, 2025.

By letter dated August 1, 2025, the Executive Director notified Monroe Township that, in accordance with N.J.A.C. 7:50-3.32, the 2025 Housing Element and Fair Share Plan was deemed incomplete until the necessary implementing ordinances were adopted and submitted to the Commission for certification.

On February 11, 2026, the Monroe Township Council adopted Ordinance O:06-2026, approving the Hightop Redevelopment Plan, for the purpose of implementing the 2025 Housing Element and Fair Share Plan. The Pinelands Commission received a certified copy of Ordinance O:06-2026 on March 5, 2026.

By letter dated March 23, 2026, the Executive Director notified the Township that the 2025 Housing Element and Fair Share Plan and Ordinance O:06-2026 would require formal review and approval by the Pinelands Commission.

II. Master Plans and Land Use Ordinances

The following master plan amendment and ordinance have been submitted to the Pinelands Commission for certification:

- * 2025 Housing Element and Fair Share Plan, dated June 12, 2025, adopted by the Planning Board on June 25, 2025
- * Ordinance O:06-2026, adopting the Hightop Redevelopment Plan, introduced on January 28, 2026, and adopted on February 11, 2026

These documents have been reviewed to determine whether they conform with the standards for certification of municipal master plans and land use ordinances as set out in N.J.A.C. 7:50-3.39 of the Pinelands Comprehensive Management Plan. The findings from this review are presented below. The numbers used to designate the respective items correspond to the numbers used to identify the standards in N.J.A.C. 7:50-3.39.

1. Natural Resource Inventory

Not applicable.

2. Required Provisions of Master Plans and Land Use Ordinances Relating to Development Standards

2025 Housing Element and Fair Share Plan

The 2025 Housing Element and Fair Share Plan addresses the Township's fourth-round affordable housing obligation. The Plan includes updated data and analysis on the Township's current and projected demographic, housing stock, and employment characteristics, as well as updated information on completed and proposed mechanisms to address the Township's affordable housing obligation. The Plan indicates a present need of 50 units and a fourth-round prospective need of 303 units.

The Township's affordable housing obligation is partially addressed through a combination of existing, under-construction, and approved affordable housing sites, as well as several proposed sites. Within the Pinelands Area portion of the Township, these include the Williamstown Square Redevelopment Area and the Acme Redevelopment Area, both located in a Pinelands Regional Growth Area. The Commission previously certified redevelopment plans for both areas, most recently through Ordinance O:27-2020 for the Williamstown Square Redevelopment Area and Ordinance O:16-2019 for the Acme Redevelopment Area. The projects described in the 2025 Plan are consistent with these previously certified redevelopment plans.

The 2025 Housing Element and Fair Share Plan also identifies a new affordable housing site, the Hightop Redevelopment Area, within the Pinelands Area (Block 12503, Lots 16, 17, 18, and 19), where the Township intends to establish inclusionary zoning through a redevelopment plan.

Ordinance O:06-2026

Ordinance O:06-2026 adopts the Hightop Redevelopment Plan, dated January 27, 2026. The redevelopment area consists of four lots (Block 12503, Lots 16, 17, 18, and 19), totaling approximately 26 acres and fronting Clayton Road (County Route 610) and Tuckahoe Road (County Route 555) (see Exhibit #1). The redevelopment area is undeveloped and forested and contains limited wetland transition areas. It is located within the Township's Regional Growth Community Commercial (RG-C) District and entirely within a Pinelands Regional Growth Area.

The RG-C District permits a variety of nonresidential uses on lots of at least 20,000 square feet, including community and neighborhood commercial uses, planned commercial developments, large-scale anchor store developments, business and professional offices, institutional uses, recreational uses, agriculture, and public service infrastructure. Residential uses are not permitted in the RG-C District.

The redevelopment plan is intended to permit a mix of commercial and high-density residential development. Accordingly, it supersedes the underlying RG-C District while incorporating all of the district's applicable land development regulations, except where specifically modified. The plan expressly requires that all development comply with the minimum environmental standards of the Pinelands CMP.

The redevelopment plan permits single-family attached dwellings (townhouses), multi-family stacked townhouse units, and age-targeted townhouse units at a density of 11 units per acre. Townhouses are permitted on lots of at least 2,000 square feet, with up to eight units attached in a single structure. At least 20% of all units must be set aside as affordable to low- and moderate-income households. In total, the redevelopment plan permits up to 286 residential units within the redevelopment area, representing an increase in the Township's residential zoning capacity within the Regional Growth Area.

The redevelopment plan also permits a variety of commercial uses on lots of at least 25,000 square feet, including retail establishments, fast-food restaurants, car washes, and other uses permitted in the underlying RG-C District. In addition, the redevelopment plan establishes various building design, parking, signage, and landscaping standards applicable to both residential and commercial development.

Within a Regional Growth Area, the CMP permits municipalities to allow any use, except certain waste management facilities, provided that appropriate residential densities and opportunities for the use of Pinelands Development Credits (PDCs) are established (N.J.A.C. 7:50-5.28). The Township has determined that the redevelopment area is appropriate for residential development and is therefore required to provide appropriate residential density and PDC opportunities.

The CMP assigns Monroe Township's Regional Growth Area a base density of 2.0 units per privately owned upland acre and requires an additional bonus density of 1.0 unit per privately owned upland acre through the use of PDCs (N.J.A.C. 7:50-5.28(a)1). Based on these standards,

the Township must zone for at least 78 units on the 26-acre redevelopment area. As noted above, the redevelopment plan permits up to 286 units, exceeding this requirement.

Pursuant to N.J.A.C. 7:50-5.28(a)7ii, a municipality may increase residential density within a Regional Growth Area to achieve identified municipal objectives, provided that infrastructure is available or can be provided to serve the areas zoned for increased density, such areas do not include significant environmental limitations, and the use of PDCs is required for a percentage of the permitted dwelling units.

In this case, the Township is increasing density to provide an opportunity for the development of affordable housing, as outlined in its 2025 Housing Element and Fair Share Plan. As discussed further in Section 8, PDCs are required for a percentage of the permitted dwelling units. Although the area contains some wetland transition areas, these do not pose a significant environmental limitation to the overall developability of the redevelopment area. Lastly, adequate water and sewer infrastructure is available to serve the redevelopment area, as described below.

In March 1990, the Pinelands Commission entered into a memorandum of agreement with the Monroe Township Municipal Utilities Authority (MTMUA) establishing a hydrologic monitoring program. This agreement was a condition of the Commission's approval of an MTMUA sanitary sewer interceptor to serve the Township's Regional Growth Area. The approval permitted up to 3.0 million gallons per day (MGD) of wastewater to be transferred from the Atlantic Basin to the Delaware Basin, including the export of water from the Kirkwood-Cohansey aquifer out of the Pinelands, as the treated wastewater is discharged to the Delaware River.

Under the monitoring agreement, the MTMUA provides monthly average data on water use and sewer discharge for both the entire system and the Atlantic Basin portion. If wastewater discharges consistently exceed 2.4 to 2.7 MGD, the agreement requires the MTMUA to conduct additional stream monitoring. In the most recent five-year period, the average monthly wastewater discharge from the entire system was 2.18 MGD. This five-year monthly average is below the stream monitoring trigger and well below the 3.0 MGD cap.

The New Jersey Residential Site Improvement Standards (RSIS) provide design water demand estimates for single-family dwellings based on bedroom count. A full residential build-out of the redevelopment plan (286 units with no non-residential) with three-bedroom townhouses (225 gallons per day per unit) would generate approximately 64,350 gallons per day (0.06435 MGD) of water demand. This estimate is conservative, as the proposal may include two-bedroom townhouses and is also expected to include commercial development, which typically have lower water demands and would reduce the total number of residential units. The additional wastewater discharge from development permitted under the redevelopment plan is not anticipated to trigger additional monitoring under the agreement or exceed the 3.0 MGD cap.

Monroe Township's 2025 Housing Element and Fair Share Plan and Ordinance O:06-2026 are consistent with the land use and development standards of the CMP. Therefore, this standard for certification is met.

3. Requirement for Certificate of Filing and Content of Development Applications

Not applicable.

4. Requirement for Municipal Review and Action on All Development

Not applicable.

5. Review and Action on Forestry Applications

Not applicable.

6. Review of Local Permits

Not applicable.

7. Requirement for Capital Improvement Program

Not applicable.

8. Accommodation of Pinelands Development Credits

N.J.A.C. 7:50-3.39(a)8 specifies that, in order to be certified by the Commission, municipal land use ordinances must provide for sufficient residentially zoned property, in the Regional Growth Area, to be eligible for an increase in density through the use of Pinelands Development Credits (PDCs) as set forth in N.J.A.C. 7:50-5.28(a)3.

As described in Section 2 above, the Hightop Redevelopment Plan increases the residential zoning capacity of the Township's Regional Growth Area by 286 units. This increase triggers the requirement to accommodate the use of PDCs within the redevelopment area. Since the permitted densities in the redevelopment area exceed the 3.0 dwelling units per private upland acre required by the CMP, PDCs must be required for a percentage of the permitted dwelling units. The CMP further requires that this percentage be established in consideration of the type of dwelling units permitted, maximum permitted density, and the rate at which PDCs have been used in the municipality's Regional Growth Area as a whole.

The Hightop Redevelopment Plan requires the use of PDCs for 25% of all market-rate units in the redevelopment area, including age targeted units. Units required to be set aside for low- and moderate-income households are excluded from the PDC calculation, up to a maximum of 48 units or 20% of the total number of units, whichever is less. Under the redevelopment plan, this would allow for the use of up to 60 PDC rights (15 PDCs) if the redevelopment area were developed for residential use only and 48 affordable units were exempted from the PDC requirement.

Under the CMP's traditional base density/bonus density framework, the maximum *potential* rate of PDC use had an upward bound of about 33% of units. However, under that framework the use of PDCs to achieve bonus density was at the discretion of the developer. If the proposed development met the base density for the zone, there was no requirement that the developer use PDCs to achieve bonus densities. Over the past twenty years, the Commission has certified numerous zoning ordinances and redevelopment plans that include mandatory PDC requirements, typically where municipalities sought flexibility to increase density beyond CMP standards or to exempt affordable units from PDC requirements. In such cases, and given the greater certainty of PDC redemption if development occurs, the Commission has certified mandatory PDC rates generally ranging from 25% to 30%. Higher percentages have typically been required where PDC utilization has been limited within a municipality's Regional Growth Area or where PDC obligations have been shifted between zoning districts. In this case, the 25% mandatory PDC rate is appropriate given the maximum permitted density and that rate at which PDCs have been used in Monroe Township, which is third most among Regional Growth Area municipalities.

Recent amendments to the CMP expressly allow municipalities to identify housing types for which PDC use is not required, including units made affordable to low- and moderate-income households, provided that the ordinance includes provisions to guarantee the use of PDCs for other housing types or within other zoning districts in the municipality's Regional Growth Area (N.J.A.C. 7:50-5.28(a)3v). In this case, the Township has elected to exempt affordable units from PDC requirements, up to a maximum of 48 units or 20% of the total number of units, whichever is less, while requiring that 25% of the remaining units to be developed in the redevelopment area redeem PDCs. This sufficiently guarantees the use of PDCs for other housing types in the redevelopment if residential development occurs.

This standard for certification is met.

9. Referral of Development Applications to Environmental Commission

Not applicable.

10. General Conformance Requirements

Ordinance O:06-2026 is consistent with the standards and provisions of the Pinelands Comprehensive Management Plan. Therefore, this standard for certification is met.

11. Conformance with Energy Conservation

Not applicable.

12. Conformance with the Federal Act

Ordinance O:06-2026 is consistent with the standards and provisions of the Pinelands Comprehensive Management Plan. No special issues exist relative to the Federal Act. Therefore, this standard for certification is met.

13. Procedure to Resolve Intermunicipal Conflicts

The redevelopment plan related to Ordinance O:06-2026 does not affect lands that are adjacent to any other municipalities. Therefore, intermunicipal conflicts are not anticipated and this standard for certification is met.

Public Hearing

A public hearing to receive testimony concerning Monroe Township's application for certification of its 2025 Housing Element and Fair Share Plan and Ordinance O:06-2026 was duly advertised, noticed and held on April 8, 2026 at 9:30 a.m. Ms. Amber Mallm conducted the hearing, which was held remotely and broadcasted live on the Pinelands Commission's public YouTube channel. The public was provided the opportunity to call in during the public hearing to provide testimony. No testimony was provided.

Written comments on the 2025 Housing Element and Fair Share Plan and Ordinance O:06-2026 were accepted through April 10, 2026. No written comments were received.

Conclusion

Based on the Findings of Fact cited above, the Executive Director has concluded that Monroe Township's 2025 Housing Element and Fair Share Plan and Ordinance O:06-2026, adopting the Hightop Redevelopment Plan, complies with the Comprehensive Management Plan standards for the certification of municipal master plans and land use ordinances. Accordingly, the Executive Director recommends that the Commission issue an order to certify the 2025 Housing Element and Fair Share Plan and Ordinance O:06-2026 of Monroe Township.

SRG/DBL/ATM/CMO
Attachments



State of New Jersey
 THE PINELANDS COMMISSION
 PO Box 359
 NEW LISBON, NJ 08064
 (609) 894-7300
 www.nj.gov/pinelands



MIKIE SHERRILL
 Governor
 DR. DALE G. CALDWELL
 Lt. Governor

General Information: Info@pinelands.nj.gov
 Application Specific Information: AppInfo@pinelands.nj.gov

LAURA E. MATOS
 Chair
 SUSAN R. GROGAN
 Executive Director

MEMORANDUM

To: Members of the Pinelands Commission

From: Katie Elliott *KE*
 Planning Specialist

Date: April 28, 2026

Subject: No Substantial Issue Findings

During the past month, the Land Use Programs Office reviewed 19 ordinances and one Housing Element and Fair Share Plan that were found to raise no substantial issues with respect to the standards of the Pinelands Comprehensive Management Plan (CMP). They included the following:

Barnegat Township Ordinance 2026-5 – amends Chapter 55, Article XXII, Affordable Housing Requirements, of the Code of Barnegat Township. The ordinance repeals and replaces provisions addressing affordability controls, construction standards, affirmative marketing, and administrative procedures. It also revises standards for the collection, maintenance, and expenditure of affordable housing development fees.

Corbin City Ordinance 3-2026 – establishes Chapter 30, Affordable Housing Ordinance, of the Code of Corbin City. The new chapter includes provisions addressing affordability controls, mandatory set-aside requirements, construction standards, affirmative marketing, and administrative procedures. It requires that any development providing a minimum of five new housing units resulting from a municipal rezoning, Zoning Board action, use or density variance, redevelopment plan, or rehabilitation plan, and providing for densities at or above six units per acre include an affordable housing set-aside of 20 percent. The ordinance also revises standards governing the collection, maintenance, and expenditure of affordable housing development fees.

Evesham Township Revised 2025 Housing Element and Fair Share Plan – includes amendments responding to comments received from the Affordable Housing Dispute Resolution Program and the Fair Share Housing Center, as well as changes to certain compliance mechanisms. These amendments include revisions to affordable housing credits applicable to the Third and Fourth Rounds across various projects. Within the Pinelands Area portion of the Township, the only proposed affordable housing site (the VFW site) has been revised to include three duplex or twin-style buildings, all of which are to be made affordable. The site is located in the Township’s Regional Growth (RG-1) Zone within a Regional Growth Area.

Evesham Township Ordinance 11-3-2026 – amends Chapter 161, Zoning Modifications and Additional Requirements, of the Code of Evesham Township by repealing and replacing Section 2 pertaining to affordable housing requirements. These new provisions address affordability controls, mandatory set-aside requirements, construction standards, affirmative marketing, and administrative procedures. The ordinance also revises standards for the collection, maintenance, and expenditure of affordable housing development fees.

Hamilton Township Ordinance 2128-2026 – amends Chapter 203, Land Use and Development, of the Code of Hamilton Township by repealing and replacing Section 187, Affordable Housing. The ordinance includes provisions addressing affordability controls, construction standards, mandatory set-aside requirements, affirmative marketing, and administrative procedures.

Hamilton Township Ordinance 2129-2026 – amends Chapter 167, Fees, of the Code of Hamilton Township by repealing and replacing Article XI, Affordable Housing Development Fees. The ordinance also revises standards for the collection, maintenance, and expenditure of affordable housing development fees.

Hammonton Town Ordinance 2-2026 – amends Chapter 175, Land Development, of the Code of the Town of Hammonton. The ordinance repeals and replaces Section 175-162, Affordable Housing, with updated provisions addressing affordability controls, construction standards, affirmative marketing, and administrative procedures. It also repeals and replaces Section 170-50.1, Affordable Housing Development Fees, with updated standards regarding the collection, maintenance, and expenditure of affordable housing development fees. In addition, the ordinance establishes a new Section 175-163, which provides mandatory affordable housing set-aside requirements. These requirements apply to all new multifamily development (including mixed-use development) within the Downtown Zoning Districts (DT-1, DT-2, DT-3, and DT-4), as well as to any new multifamily development of five or more dwelling units or any new development of ten or more single-family attached units in any other zoning district within the Town. The ordinance requires a 20% set-aside for for-sale units and a 15% set-aside for rental units.

Manchester Township Ordinance 26-21 – amends Chapter 245, Land Use and Development, of the Code of Manchester Township. The ordinance revises Section 245-70, Cluster Development, to clarify that proposals for cluster development shall not be considered requests for variance relief unless such relief is specifically sought. Within the Pinelands Area, cluster development under this section is permitted in the Pinelands Single Family Residential (PR-40), Pinelands Rural Agriculture (PR-A), Whiting Town Residential – 40,000 square feet (WTR-40), and Whiting Town Rural Agricultural (WTR-A) districts. The PR-40 and PR-A districts are located in a Regional Growth Area, while the WTR-40 and WTR-A districts are located in a Pinelands Town.

Manchester Township Ordinance 26-22 – amends Chapter 245, Land Use and Development, of the Code of Manchester Township. The ordinance revises Article XI, Affordable Housing, by repealing and replacing provisions addressing affordability controls, construction standards, affirmative marketing, and administrative procedures. It also updates standards regarding the collection, maintenance, and expenditure of affordable housing development fees. In addition, the ordinance establishes a mandatory set-aside requirement for any development of five or more new residential units resulting from an increase in density through a use variance, zoning change, or conditional use approval for residential development.

Manchester Township Ordinance 26-25 – amends Chapter 245, Land Use and Development, of the Code of Manchester Township. The ordinance rezones an approximately 1.44-acre lot (Block 111, Lot 7) from the Whiting Town Retirement Community (WTRC) District to the adjacent Whiting Town Highway District (WTHD). The lot contains an existing single-family dwelling and is located entirely within a Pinelands Town management area. The ordinance also eliminates the Residential 20,000 Square Feet (R-20) and Multifamily (MF) overlay districts from properties located outside the Pinelands Area and repeals all references to the Multifamily (MF-6) Overlay District, which is also located outside the Pinelands Area.

Manchester Township Ordinance 26-28 – amends Chapter 245, Land Use and Development, of the Code of Manchester Township. The ordinance rezones an approximately 12-acre lot (Block 46, Lot 4) from the Residential 40,000 Square Feet (R-40) District to the adjacent Town Center (TC) District. The lot is vacant and wooded and is located outside the State-designated Pinelands Area but within a Regional Growth Area of the Pinelands National Reserve (PNR). In 2019, the Pinelands Commission certified the Township’s land development regulations and zoning plan for the PNR portion of the Township.

Monroe Township Ordinance O:20-2026 – amends the Hexa Builders Redevelopment Plan, which is located in a Regional Growth Area and was previously certified by the Pinelands Commission. The ordinance repeals Ordinance O:02-2025, which had amended the redevelopment plan to permit data centers, office space specific to data center operations, and associated accessory uses. These uses are no longer permitted within the redevelopment area.

Monroe Township Ordinance O:25-2026 – amends Chapter 175, Land Management, of the Code of Monroe Township by establishing a new Section 175-163.5, “Data Centers”. The purpose of this section is to regulate and prohibit the establishment and operation of data centers within the Township. It defines the term “data center” and expressly prohibits all data centers and related uses within Monroe Township.

Ocean Township Ordinance 2026-7 – amends Chapter 410, Zoning, of the Code of Ocean Township. The ordinance repeals and replaces Article XXIII, Affordable Housing. It establishes provisions addressing affordability controls, construction standards, mandatory set-aside requirements, affirmative marketing, and administrative procedures. It requires that any development providing a minimum of five new housing units resulting from a municipal rezoning, Zoning Board action, use or density variance, redevelopment plan, or rehabilitation plan, and providing for densities at or above six units per acre include an affordable housing set-aside of 20 percent. The ordinance also revises standards for the collection, maintenance, and expenditure of affordable housing development fees.

Ocean Township Ordinance 2026-8 – repeals Chapter 83, Affordable Housing, and Chapter 410, Article XXI, Affordable Housing Development Fees, of the Code of Ocean Township. Revised standards for the collection, maintenance, and expenditure of affordable housing development fees are established and recodified in Ordinance 2026-7 above.

Pemberton Township Ordinance 13-2026 – amends Chapter 190, Zoning, of the Code of Pemberton Township. The ordinance revises the definition of the term “data center” and expressly prohibits data centers in the General Commercial/Light Industrial-2 (GCLI-2) District, which is located within a Pinelands Agricultural Production Area.

Stafford Township Ordinance 2026-02 – amends Chapter 130, Land Use and Development, of the Code of Stafford Township. The ordinance amends Article XV, Affordable Housing, by repealing and replacing provisions addressing affordability controls, construction standards, affirmative marketing, and administrative procedures. It requires that any development providing a minimum of five new housing units resulting from a municipal rezoning, Zoning Board action, use or density variance, redevelopment plan, or rehabilitation plan, and providing for densities at or above six units per acre include an affordable housing set-aside of 20 percent.

Stafford Township Ordinance 2026-03 – amends Chapter 130, Land Use and Development, of the Code of Stafford Township. The ordinance amends Section 130-88.1, Mandatory Development Fees, by repealing and replacing standards for the collection, maintenance, and expenditure of affordable housing development fees.

Upper Township Ordinance 001-2026 – amends Chapter 20, Zoning, of the Code of Upper Township by establishing a cannabis overlay zone within the Commercial District (CM2). The overlay zone permits Class 5 cannabis retail businesses on specific lots within the CM2 District. The CM2 District is located outside of the State-designated Pinelands Area but within a Regional Growth Area of the Pinelands National Reserve (PNR). In 2008, the Pinelands Commission certified the Township’s land development regulations and zoning plan for the PNR portion of the Township.

Waterford Township Ordinance 2026-12 – amends Chapter 176, Land Use, Development and Zoning, of the Code of Waterford Township. The ordinance amends Section 176-116 (Use Restrictions in All Zones) to expressly prohibit data centers in all zoning districts within the Township.