

THE USE OF THE COLOR PURPLE
FOR
VARIABLE MESSAGE SIGNS

BY

T. D. DAVIS

OF

BUREAU OF OPERATIONS RESEARCH
DIVISION OF RESEARCH AND DEVELOPMENT
NEW JERSEY DEPARTMENT OF TRANSPORTATION

APRIL 1978

TABLE OF CONTENTS

	<u>Page</u>
LIST OF FIGURES	i
LIST OF TABLES	ii
BACKGROUND	1
OBJECTIVES	2
Explanation of Terms	2
Materials Limitations	2
PROCEDURE	3
RESULTS	4
Panel Attention Attracting Characteristics	4
Effect of Panel Color on Matrix Legibility	7
Matrix Attention Attracting Characteristics	9
CONCLUSIONS AND RECOMMENDATIONS	14
APPENDIX	15

LIST OF FIGURES

<u>FIGURE</u>		<u>PAGE</u>
1	Demonstration I	5
2	Demonstration II	11
3	Magnetic Disk Matrix Module	11
4	Inadequacy of Matrix Characters to Stand Out in Comparison with 16" High Button Copy	13

LIST OF TABLES

<u>TABLE</u>		<u>PAGE</u>
1	Panel Color Identification	6
2	Panel Color Brightness	6
3	Effect of Panel Color on Matrix Legibility	7
4	Effect of Panel Color on Legibility Inadequacy	8
5	Legibility of Matrix Characters	10
6	Legibility Inadequacy of Matrix Characters	10
7	Matrix Characters Ranked According to Their Capacity to Stand Out in Comparison with 16" High Button Copy	12

BACKGROUND

To better optimize the flow of traffic through the Newark Airport Interchange, New Jersey is developing a Motorist Advisory System through the cooperation of the New Jersey Department of Transportation, the National Advisory Committee on Urban Traffic Control Devices of the Federal Highway Administration, and the consultant, Edwards and Kelcey, Inc.

The system will utilize variable message and fixed message signs to divert large volumes of interchanging and through traffic to alternate routes. The signing used should be highly visible and distinct from normal guidance signing indicating the desirability of the use of a new color. The New Jersey Department of Transportation advised the consultant to use a color unassigned by the Manual on Uniform Traffic Control Devices, and the consultant recommended purple since it seemed to provide:

1. A high degree of contrast with the green background of existing route guidance signs.
2. A high degree of contrast with white lettering or clear bulbs or yellow disks which will be used in constructing the sign message.
3. A distinctly different sign which will have good attention attracting abilities.

OBJECTIVES

The original purpose of the demonstration was to evaluate how well purple attracted the attention of the motorist. An alternative to using color for attracting attention is to use the message itself. Therefore, the message was included in the demonstration as a basis for determining if either the message or the color or both should be used to attract the attention of the motorist.

The demonstration was held under the following expected environmental and driver conditions:

1. Three ambient light situations -- sun on sign face, sun in back of sign, night with lights.
2. Viewing distances of 600 or more feet.
3. With and without color blindness.
4. With and without use of sunglasses.

Explanation of Terms

Character - The arrangement of bulbs or disks into a particular symbol, i.e. "2," "E," etc.

Font - The distinct bulb or disk arrangement used in a matrix to display a particular character.

Matrix - The grid that produces a character composed of small discrete bulbs or disks.

Matrix Background - The immediate background of the matrix within the module.

Module - The unit containing the matrix.

Panel - The background on which the matrix modules are mounted.

Material Limitations

Unlike conventional characters which are composed of continuous lines

and line segments, the matrix characters are composed of small discrete dots. The way these dot matrix characters are arranged can effect their legibility.

Under ideal conditions each matrix would have the same character arrangement or font. Unfortunately, the matrices furnished by the manufacturer did not have the same font. The displays used only one or two matrix characters, but the real setup would use several words, thus extending the panel well beyond the eight foot length used in the demonstration. Also, the panels used to support the matrices showed much more background than would actually be shown in the field.

PROCEDURE

During the demonstration questionnaires were filled out by key people from Traffic Engineering, Operations Research, and the consultant. Following is the number of participants for each condition:

	NORMAL VISION	SUNGLASSES	COLOR BLIND
Night	9	0	1
Sun in Back of Sign	11	2	1
Sun in Front of Sign	11	2	1

First, each participant answered questions regarding color blindness, visual acuity, and use of sunglasses. Also, each participant was to answer his questionnaire independently. Sample questionnaires may be found in the Appendix.

For the first demonstration (I), the participants evaluated three 4' x 8' colored panels with three kinds of matrix modules mounted on each (Figure 1). The three colors were black, green, and purple. Two colors were set up side by side, and the participants filled in a questionnaire regarding the color of each panel and the brightest of the two. Also,

each matrix character was evaluated for legibility. To cover all possible combinations, a total of three side by side displays were set up, and questionnaires were filled in for each display.

The first demonstration (I) was conducted under each of the following ambient light conditions: night, sun in back of sign, and sun in front of sign. Also, the displays were viewed from a distance of 600 feet or more.

A second demonstration (II) was designed to answer the following questions: How would the various types of matrix characters compare with a standard 16" high button copy? How would the matrix characters compare with each other?

The demonstration was set up as in Figure 2, and the participants evaluated the attention attracting characteristics of each type of matrix. Next, the display was shown again with 1.5" disk on black cardboard matrix replaced with a 2.2" disk on black cardboard matrix, and the participants filled out another questionnaire. Demonstration II was conducted from a distance of 600 feet and the sun was in back of the sign.

RESULTS

Panel Attention Attracting Characteristics

The attention getting characteristics of a panel are measured by how well it is identified and how bright it is. From Table 1 under all ambient light conditions, the majority of the participants correctly identified both the purple and the green panels, and from Table 2 under the same conditions both the purple and the green panels were chosen as being equally bright.

FIGURE 1

FIRST DEMONSTRATION

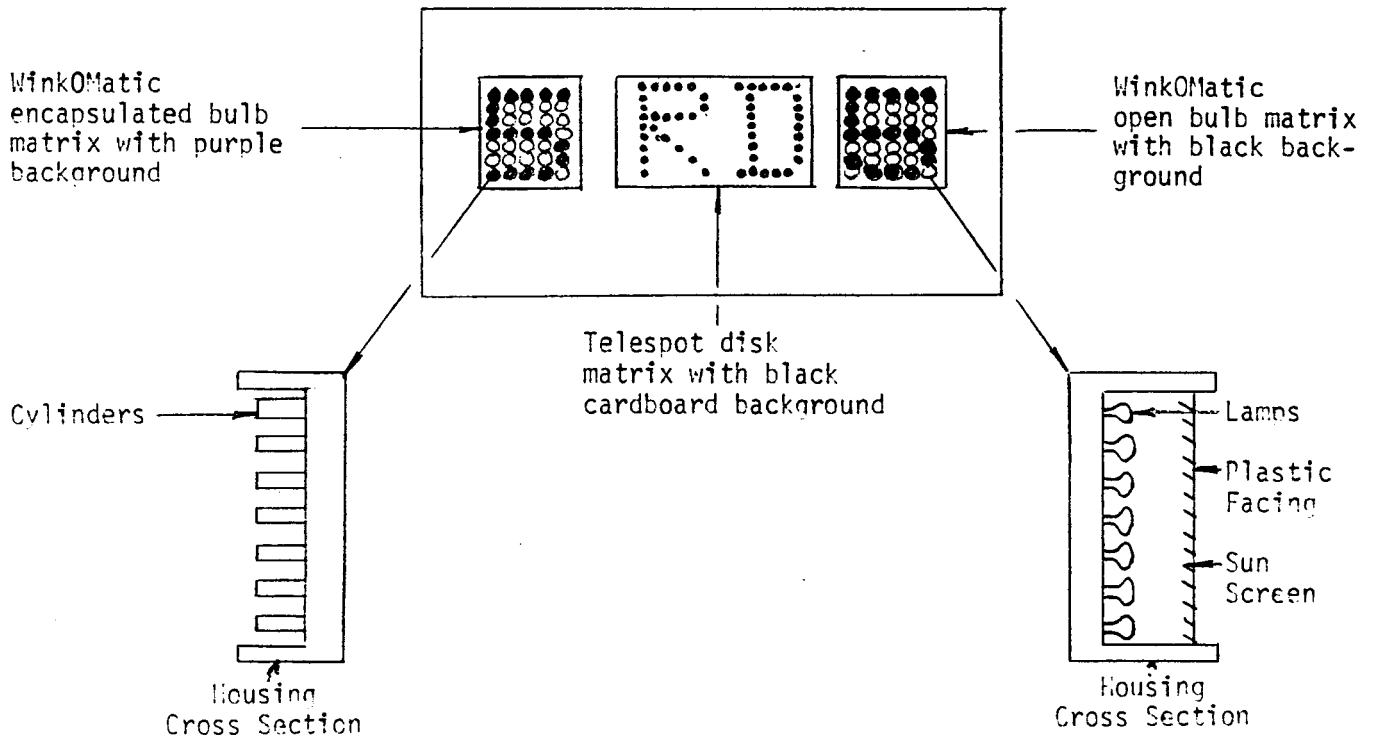

TABLE 1

	<u>PANEL COLOR IDENTIFICATION</u>					
	<u>NIGHT</u>		<u>SUN IN BACK OF SIGN</u>		<u>SUN IN FRONT OF SIGN</u>	
	NO. ^a	%	NO. ^b	%	NO. ^b	%
Black	4	22	21	95	22	100
Purple	17	94	22	100	22	100
Green	18	100	21	95	22	100

^aNumber of times out of a possible 18 times a color was identified correctly.

^bNumber of times out of a possible 22 times a color was identified correctly.

TABLE 2

	<u>PANEL COLOR BRIGHTNESS</u>					
	<u>NIGHT</u>		<u>SUN IN BACK OF SIGN</u>		<u>SUN IN FRONT OF SIGN</u>	
	NO. ^a	%	NO. ^b	%	NO. ^b	%
Black	1.5	8	0.5	2	0.0	0
Purple	16.0	89	15.5	70	16.5	75
Green	9.5	3	17.0	77	16.5	75

^aNumber of times out of a possible 18 times each color was chosen as the brightest over the other two. Figures adjusted to account for the respondents who said the colors were equally bright.

^bNumber of times out of a possible 22 times each color was chosen as the brightest over the other two.

Effects of Panel Color on Matrix Legibility

Referring to Table 3, under all ambient light conditions the majority of the participants felt that the legibility of the encapsulated bulb matrix was most improved when a purple panel was used rather than either a black or a green panel. Under the same conditions, the legibility of the disk on cardboard matrix was improved when a black panel was used rather than a purple panel, and the legibility of the open bulb matrix was improved when a purple panel was used rather than a black panel.

TABLE 3

EFFECT OF PANEL COLOR ON MATRIX LEGIBILITY

	<u>Encapsulated Bulb</u>			<u>Disk on Cardboard</u>			<u>Open Bulb</u>		
	Black	Purple	Green	Black	Purple	Green	Black	Purple	Green
Night ^a	42	58	46	39	22	46	19	20	8
Sun in Back ^b of sign	86	91	90	14	9	0	0	0	10
Sun in Front ^b of sign	0	4	0	100	91	100	0	5	0

^aPercentage of times out of a possible 18 times that a matrix was chosen as the most legible of the three.

^bPercentage of times out of a possible 22 times that a matrix was chosen as the most legible of the three.

Referring to the far right hand column of Table 4, it is interesting to note that under all ambient light conditions the legibility of all three matrices as a whole was believed to be least inadequate when a purple rather than either a black or a green panel was used.

TABLE 4

EFFECT OF PANEL COLOR ON LEGIBILITY INADEQUACY*

	ENCAPSULATED			DISK			OPEN			NO MATRICES CHOSEN AS INADEQUATE		
	Black	Purple	Green	Black	Purple	Green	Black	Purple	Green	Black	Purple	Green
Flight	4	6	4	28	31	28	32	19	32	36	44	36
Sun in Back of Sign	0	5	0	80	74	100	20	10	0	0	11	0
Sun in Front of Sign	60	40	64	0	0	0	40	13	29	0	47	7

*Percentage of times the legibility of a matrix was chosen as inadequate.

Matrix Attention Attracting Characteristics

The attention attracting characteristics of matrix characters are measured by how legible they are and by how well they stand out in comparison with the standard button copy used on guide signs.

In Demonstration I three types of matrix characters were evaluated for legibility and legibility inadequacy: the encapsulated bulb matrix, the 1.5" disk on cardboard matrix, and the open bulb matrix. From Table 5 under all ambient light conditions, the majority of the participants chose the open bulb matrix as the least legible of the three matrices and from Table 6 the participants had mixed feelings as to the legibility inadequacy of the three matrices.

Demonstration II (Figure 2) was held to help determine how well the different types of matrix characters stood out in comparison with the standard button copy used on guide signs. In addition to the three matrix characters used in Demonstration I, another type of matrix character was introduced -- a 2.2" magnetic disk module (Figure 3). This module was added for the following reasons: it was more realistic looking than the disk on cardboard matrix, it was lighted internally, and it was unavailable for use in Demonstration I.

TABLE 5
LEGIBILITY OF MATRIX CHARACTERS

	<u>NIGHT</u>		<u>SUN IN BACK OF SIGN</u>		<u>SUN IN FRONT OF SIGN</u>	
	NO. ^a	%	NO. ^b	%	NO. ^c	%
Encapsulated	26.3	49	57.0	89	1.0	2
Disk	19.3	36	5.0	8	64.0	97
Open	8.3	15	2.0	3	1.0	1

^aNumber of times out of a possible 54 times each matrix was chosen as the most legible, Figures adjusted to account for the respondents who chose more than one matrix as the most legible.

^bNumber of times out of a possible 64 times each matrix was chosen as the most legible.

^cNumber of times out of a possible 66 times each matrix was chosen as the most legible.

TABLE 6
LEGIBILITY INADEQUACY OF MATRIX CHARACTERS

	<u>NIGHT</u>		<u>SUN IN BACK OF SIGN</u>		<u>SUN IN FRONT OF SIGN</u>	
	NO. ^a	%	NO. ^b	%	NO. ^c	%
Encapsulated	2.0	4	1.0	1	25.0	56
Disk	13.0	29	51.5	83	3.0	6
Open	12.0	27	7.5	12	8.5	18
None Inadequate	17.0	38	2.0	3	8.0	17

^aNumber of times out of a possible 44 times the legibility of each matrix was chosen as inadequate. Figures adjusted to account for the respondents who chose more than one matrix as inadequate. Some of the respondents felt that none of the matrices were inadequate.

^bNumber of times out of a possible 62 times the legibility of each matrix was chosen as inadequate.

^cNumber of times out of a possible 45 times the legibility of each matrix was chosen as inadequate.

FIGURE 2

DEMONSTRATION II

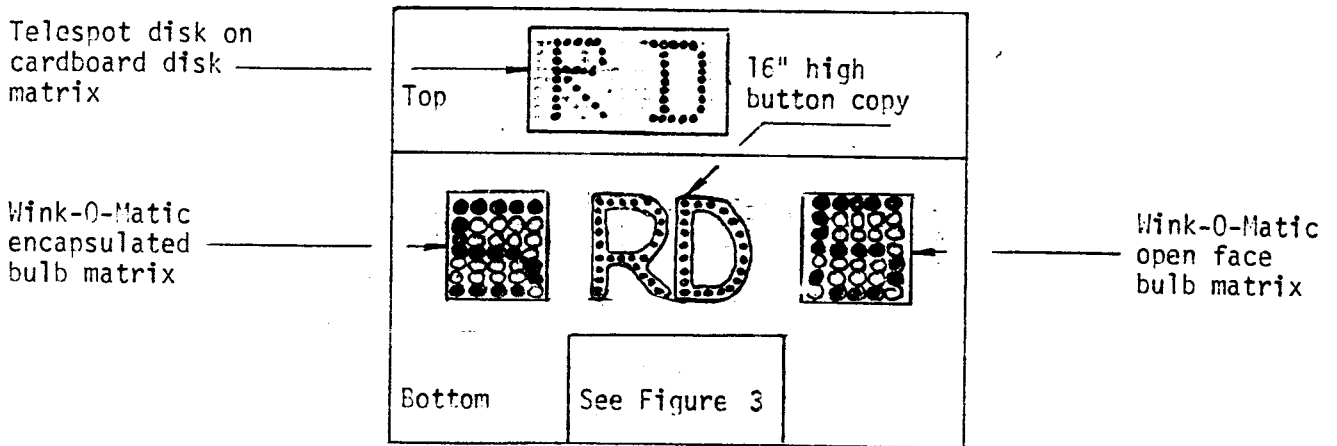
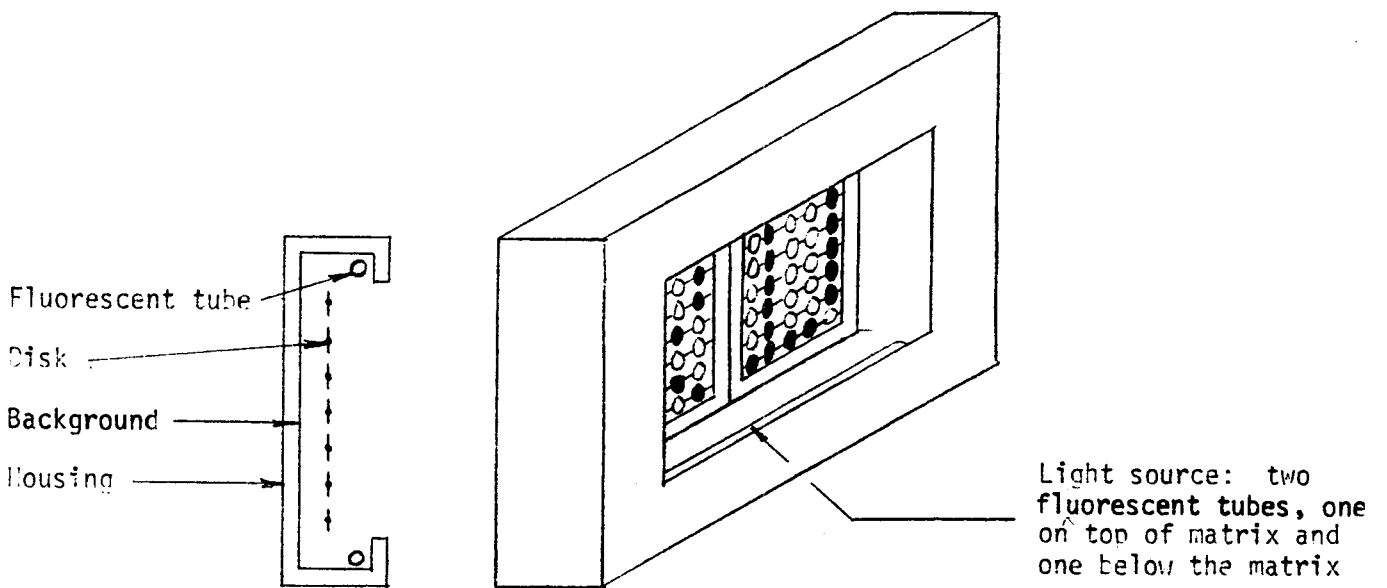

FIGURE 3

MAGNETIC DISK MATRIX MODULE



In Demonstration II the twelve participants viewed the sign from a distance of six hundred feet, and only one ambient light condition was used -- sun behind the sign. Although two displays were shown, the only difference between the first and the second was that the 1.5" disk on cardboard matrix was replaced by a 2.2" disk on cardboard matrix.

In Table 7 the matrix characters were ranked according to their capacity to stand out in comparison with a standard 16" high button copy. The participants felt that the 2.2" magnetic disk matrix stood out more than both the 1.5" and the 2.2" disk on cardboard matrices, and from Figure 4 they felt that the 2.2" magnetic disk matrix was less inadequate in standing out in comparison to the disk on cardboard matrices.

TABLE 7

MATRIX CHARACTERS RANKED ACCORDING TO THEIR CAPACITY TO STAND OUT IN COMPARISON WITH 16" HIGH BUTTON COPY^a

<u>CHARACTER</u>	<u>DISPLAY 1^b</u>	<u>DISPLAY 2^c</u>
16" high button copy	1	2
Encapsulated bulb matrix	2	1
Open bulb matrix	3	3
2.2" magnetic disk matrix	4	4
1.5" disk on cardboard matrix	5	-
2.2" disk on cardboard matrix	-	5

^aEach character was ranked on a scale of one to five, one being the highest rank and five being the lowest rank.

^b1.5" disk on cardboard used.

^c2.2" disk on cardboard used.

NOTE: Sun was behind panel.

FIGURE 4

INADEQUACY OF MATRIX CHARACTERS TO STAND OUT
IN COMPARISON WITH 16" HIGH BUTTON COPY^a

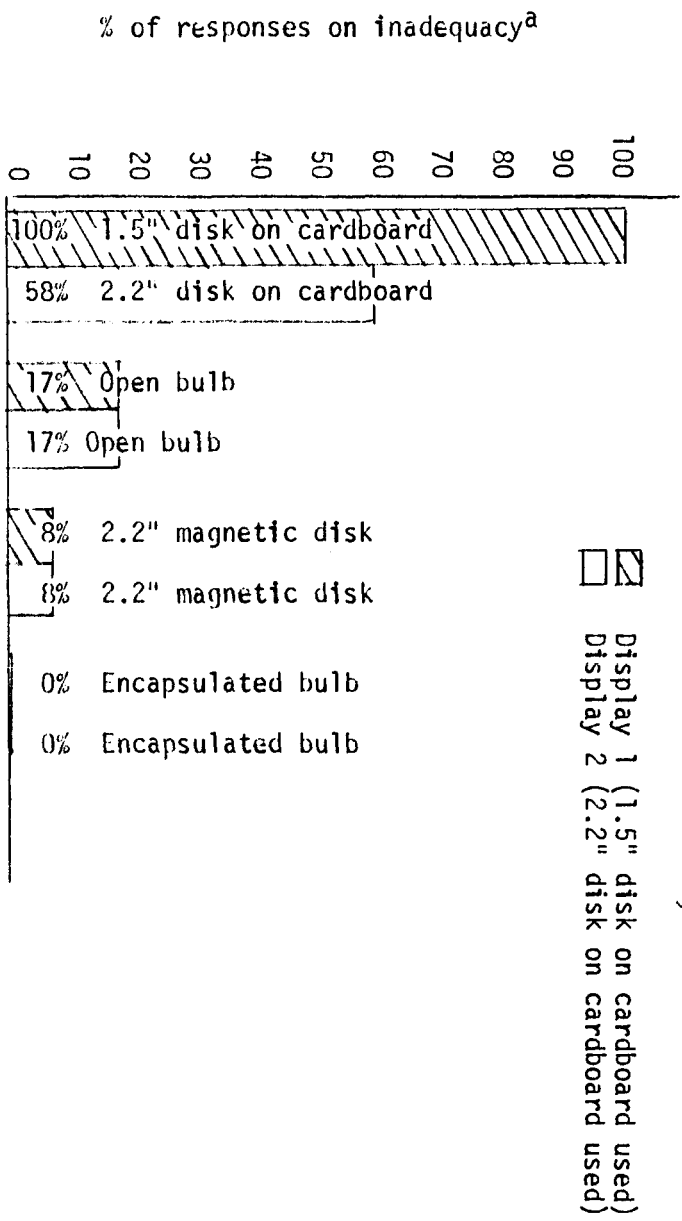

^aPercentage of times a matrix was chosen as inadequate using 16" high button copy as a reference.

NOTE: Sun was behind panel.

CONCLUSIONS AND RECOMMENDATIONS

The first choice would be to use a purple panel mounted with encapsulated bulb matrix modules. The purple panel not only offers a high degree of contrast with existing green guide signs, but it also enhances the legibility of the encapsulated bulb matrix characters.

The second choice would be to use a black panel mounted with magnetic disk modules. The black panel improves the legibility of the magnetic disk characters. The magnetic disk module may also be desirable in view of its easier maintenance and lower energy consumption, though consideration should be given to lighting the matrix at all times except when the sun is on the face of the sign.

The responses to different panel colors varied less than the responses to different matrix types, indicating that matrix legibility seems to be a more important factor in determining sign perception than panel color and brightness. It should be noted that in the field less panel color would be showing than was displayed in the demonstration.

For those who used sunglasses, the results were the same except that purple was identified correctly less often than both black and green, and the results were unchanged for the one participant who was red/green color blind.

As a result of observations made by several engineers at night from an automobile with headlights on, it was noticed that the button copy was the brightest of all the characters used. Since it is expected that the button copy will be used at times with VMS matrices, a sufficient amount of light should be reflected or emit from the matrices to match the bright buttons.

APPENDIX

SPECIFICATIONS OF VARIABLE MESSAGE MATRICES USED

Encapsulated System

Bulbs: 1.5" diameter G.E. #1385 low voltage (17 to 22 v.) spotlight design.

Bulb protection: Individual metal cylinders the face of which was blue filtered glass. The blue filtered glass tended to make the bulbs appear white rather than yellowish.

Matrix Background Color: Purple

Module Size: 22" high by 15" wide

Matrix Size: five by seven

Open System

Bulbs: 1.5" diameter G.E. 25W., 120V. spotlight design

Bulb protection: A plastic face covering the front of the module. A sun screen, to help keep out direct sunlight, was behind the plastic face.

Matrix Background Color: Black

Module Size: 22.5" high by 16" wide

Matrix Size: five by seven

Magnetic Disk

The 2.2" disks were colored a fluorescent yellow/green (not retroreflective).

Matrix Background Color: Black

Module Size: 38.5" high by 49.5" wide

Matrix Size: five by seven

SPECIFICATIONS OF BACKGROUNDS USED

Flat Black

Standard Interstate Green

Purple paint with Munsell Notation - hue 10P, value 4, chroma 8

CHANGEABLE MESSAGE BACKGROUND
COLOR DEMONSTRATION

Name _____

Telephone Number _____

Do you mind answering the below questions regarding your vision? yes no

1. Have you ever been tested for color blindness?

 yes no

If tested, are you color blind?

- no
- red/green
- blue/yellow
- all colors
- other, explain _____

- don't know

If not tested, do you have any problems with color vision that you are aware of?

- no
- yes, explain _____

2. Do you need to wear glasses for nearsightedness?

yes no

If yes, do you plan to wear them?

yes no

Do you have a problem seeing distances (with glasses, if needed)?

yes no

This information will be held in confidence and your name will not be associated with any reported results.

CHANGEABLE MESSAGE BACKGROUND
COLOR DEMONSTRATION

Initials _____

Condition:

SIDE BY SIDE DISPLAY

Ambient Light

- Sun in back of sign
- Sun in face of sign
- Cloudy - no sun
- Night

Please enter your observations independent of discussion
with other observers.

1. What is the apparent color of the LEFT SIGN? _____
 Can't tell
2. What is the apparent color of the RIGHT SIGN? _____
 Can't tell
3. In comparing background brightnesses which statement
seems best?
 They are equally bright
 Left sign is brighter
 Right sign is brighter
4. In comparing the color differences, which statement
seems best?
 They are very different
 Not very different
 Not different at all.

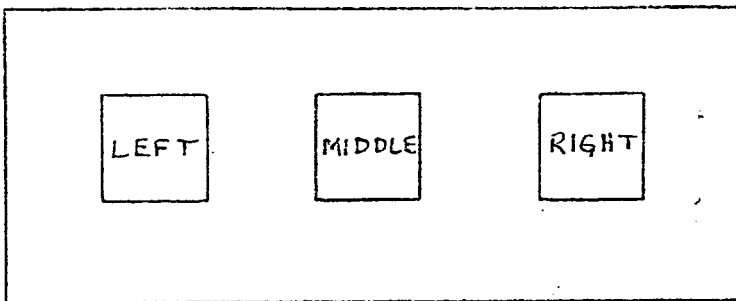

5. Which of the figures on the LEFT SIGN is the most legible?

left middle right

Which is least legible?

left middle right

Why? Explain _____

Which, if any, are inadequate?

left middle right

6. When the figures were moved to the RIGHT SIGN, did the legibility seem to change?

left same worse better

middle same worse better

right same worse better

Which, if any, seem inadequate?

left middle right

Which of the figures on the RIGHT SIGN is most legible?

left middle right

Which is least legible?

left middle right

Why? Explain _____

Condition:

BOTTOM AND TOP DISPLAY

7. What is the apparent color of the sign on the bottom?

_____ Can't tell

What is the apparent color of the sign on top?

_____ Can't tell

8. There are four elementary requirements which every traffic control device should meet: 1) it should compel the attention; 2) it should convey a simple, clear meaning at a glance; 3) it should allow adequate time for easy response; and 4) it should command the respect of the road users for whom it is intended. The second and third requirements do not relate to a background color as strongly as do the first and fourth.

In your opinion, how does this display rate, given these two requirements?

Compels attention Adequately

Inadequately

Commands respect Adequately

Inadequately

Any comments? _____

9. After having seen all the displays, which background color for changeable messages did you prefer? _____

10. Which matrix figures did you prefer?

LEFT _____

MIDDLE _____

RIGHT _____

Do you have any further comments or observations.

CHANGEABLE MESSAGE BACKGROUND
COLOR DEMONSTRATION II

In a sign display, letters and figures of different types - button copy, bulb, and disc - are in competition with each other for the attention of the motorist. At the same time, the contrast between the background and the figure must be adjusted to produce adequate legibility. Since the shape of the figure is a controlling factor in legibility and differently shaped figures are being displayed, the clarity of the figure is a more appropriate measure of its readability.

Please enter your observations independent of discussion with other observers.

Ambient Light

- Sun in back of sign
- Cloudy -- no sun
- Night

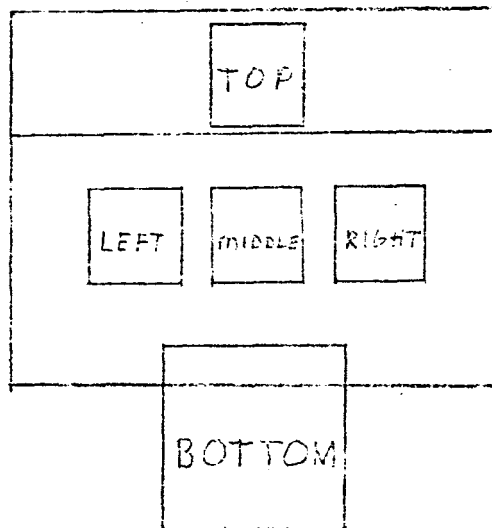

One of the figures on the top, bottom, left, and right will be in competition with the center figure for the motorist's attention when actually used in the field.

1. How do these figures compete with the center figure for your attention?

	Adequately	Inadequately
Top	<input type="checkbox"/>	<input type="checkbox"/>
Right	<input type="checkbox"/>	<input type="checkbox"/>
Bottom	<input type="checkbox"/>	<input type="checkbox"/>
Left	<input type="checkbox"/>	<input type="checkbox"/>

2. Rank the figures according to how well you feel they "stand out" in competing for your attention. Enter the figure that "stands out" the most next to "#1" and the figure that stands out the least next to #5. Do not enter more than one figure next to a rank.

- #1 _____
- #2 _____
- #3 _____
- #4 _____
- #5 _____