

Section 4

Basic Geometric Design Elements

4.1 General

Geometric highway design pertains to the visible features of the highway. It may be considered as the tailoring of the highway to the terrain, to the controls of the land usage, and to the type of traffic anticipated.

Design parameters covering highway types, design vehicles, and traffic data are included in Section 2, "General Design Criteria."

This section covers design criteria and guidelines on the geometric design elements that must be considered in the location and the design of the various types of highways. Included are criteria and guidelines on sight distances, horizontal and vertical alignment, and other features common to the several types of roadways and highways.

In applying these criteria and guidelines, it is important to follow the basic principle that consistency in design standards is of major importance on any section of road. The highway should offer no surprises to the driver, bicyclist or pedestrian in terms of geometrics. Problem locations are generally at the point where minimum design standards are introduced on a section of highway where otherwise higher standards should have been applied. The ideal highway design is one with uniformly high standards applied consistently along a section of highway, particularly on major highways designed to serve large volumes of traffic at high operating speeds.

4.2 Sight Distances

4.2.1 General

Sight distance is the continuous length of highway ahead visible to the driver. In design, two sight distances are considered: passing sight distance and stopping sight distance. Stopping sight distance is the minimum sight distance to be provided at all points on multi-lane highways and on two-lane roads when passing sight distance is not economically obtainable.

Stopping sight distance also is to be provided for all elements of interchanges and intersections at grade, including driveways.

Table 4-1 shows the standards for passing and stopping sight distance related to design speed.

4.2.2 Passing Sight Distance

Passing sight distance is the minimum sight distance that must be available to enable the driver of one vehicle to pass another vehicle, safely and comfortably, without interfering with the speed of an oncoming vehicle traveling at the design speed, should it come into view after the overtaking maneuver is started. The sight distance available for passing at any place is the longest distance at which a driver whose eyes are 3.5 feet above the pavement surface can see the top of an object 3.5 feet high on the road.

Passing sight distance is considered only on two-lane roads. At critical locations, a stretch of four-lane construction with stopping sight distance is sometimes more economical than two lanes with passing sight distance.

**Table 4-1
Sight Distances for Design**

Design Speed Mph	Sight Distance in feet	
	Stopping Minimum	Passing* Minimum
25	155	900
30	200	1090
35	250	1280
40	305	1470
45	360	1625
50	425	1835
55	495	1985
60	570	2135
65	645	2285
70	730	2480

* Not applicable to multi-lane highways.

4.2.3 Stopping Sight Distance

The minimum stopping sight distance is the distance required by the driver of a vehicle, traveling at a given speed, to bring his vehicle to a stop after an object on the road becomes visible. Stopping sight distance is measured from the driver's eyes, which is 3.5 feet above the pavement surface, to an object 2 feet high on the road.

The stopping sight distances shown in Table 4-1 should be increased when sustained downgrades are steeper than 3 percent. Increases in the stopping sight distances on downgrades are indicated in AASHTO, *"A Policy on Geometric Design of Highways and Streets."*

4.2.4 Stopping Sight Distance on Vertical Curves

See Section 4.4.4 "Standards for Grade" for discussion on vertical curves.

4.2.5 Stopping Sight Distance on Horizontal Curves

Where an object off the pavement such as a longitudinal barrier, bridge pier, bridge rail, building, cut slope, or natural growth restricts sight distance, the minimum radius of curvature is determined by the stopping sight distance.

Stopping sight distance for passenger vehicles on horizontal curves is obtained from Figure 4-A. For sight distance calculations, the driver's eyes are 3.5 feet above the center of the inside lane (inside with respect to curve) and the object is 2 feet high. The line of sight is assumed to intercept the view obstruction at the midpoint of the sight line and 2.75 feet above the center of the inside lane. Of course, the midpoint elevation will be higher or lower than 2.75 feet, if it is located on a sag or crest vertical curve respectively. The horizontal sightline offset (HSO) is measured from the center of the inside lane to the obstruction.

The general problem is to determine the clear distance from the centerline of inside lane to a median barrier, retaining wall, bridge pier, abutment, cut slope, or other obstruction for a given design speed. Using radius of curvature and sight distance for the design speed, Figure 4-A illustrates the HSO, which is the clear distance from centerline of inside lane to the obstruction. When the design speed and the clear distance to a fixed obstruction are known, this figure also gives the required minimum radius which satisfies these conditions.

When the required stopping sight distance would not be available because of an obstruction such as a railing or a longitudinal barrier, the following alternatives shall be considered: increase the offset to the obstruction, increase the horizontal radius, or do a combination of both. However, any alternative selected should not require the width of the shoulder on the inside of the curve to exceed 12 feet because the potential exists that motorists will use the shoulder in excess of that width as a passing or travel lane. This is especially pertinent where bicyclists can be expected to operate.

When determining the required HSO distance on ramps, the location of the driver's eye is assumed to be positioned 6 feet from the inside edge of pavement on horizontal curves.

The designer is cautioned in using the values from Figure 4-A since the stopping sight distances and HSO are based upon passenger vehicles. The average driver's eye height in large trucks is approximately 120 percent higher than a driver's eye height in a passenger vehicle. However, the required minimum stopping sight distance can be as much as 50 percent greater than the distance required for passenger vehicles. On routes with high percentages (10 percent or more) of truck traffic, the designer should consider providing greater horizontal clearances to vertical sight obstructions to accommodate the greater stopping distances required by large trucks. The approximate HSO required for trucks is 2.5 times the value obtained from Figure 4-A for passenger vehicles.

In designing the roadway to provide a particular stopping sight distance the designer is advised to consider alternatives. A wider sidewalk, shoulder or bike lane increases the sight triangle, see Section 6-03. Curb extensions and parking restrictions allow the driver to see pedestrians and cross traffic more easily.

MINIMUM STOPPING SIGHT DISTANCE ON HORIZONTAL CURVES

FIGURE: 4-A

BDC07MR-01

D = Degree of Curve

$$D = \frac{5730}{R}$$

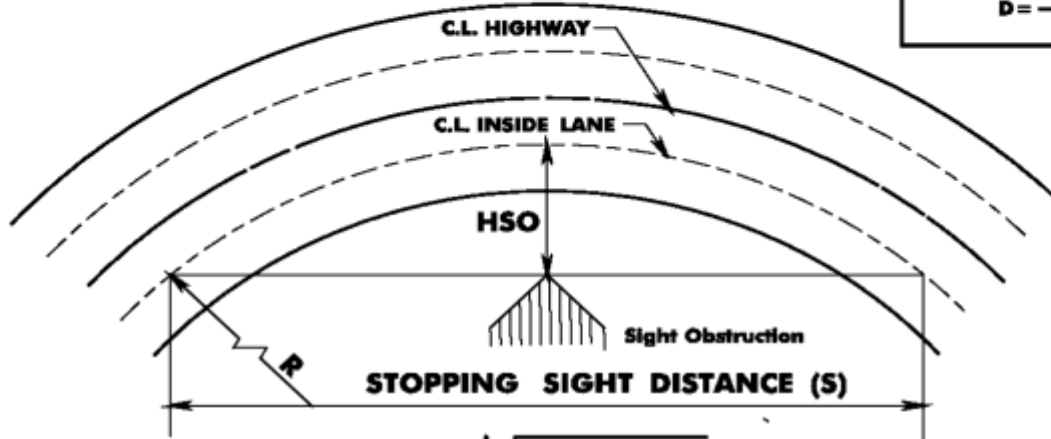

$$HSO = R - \sqrt{R^2 - \left(\frac{S}{2}\right)^2}$$

R = Radius

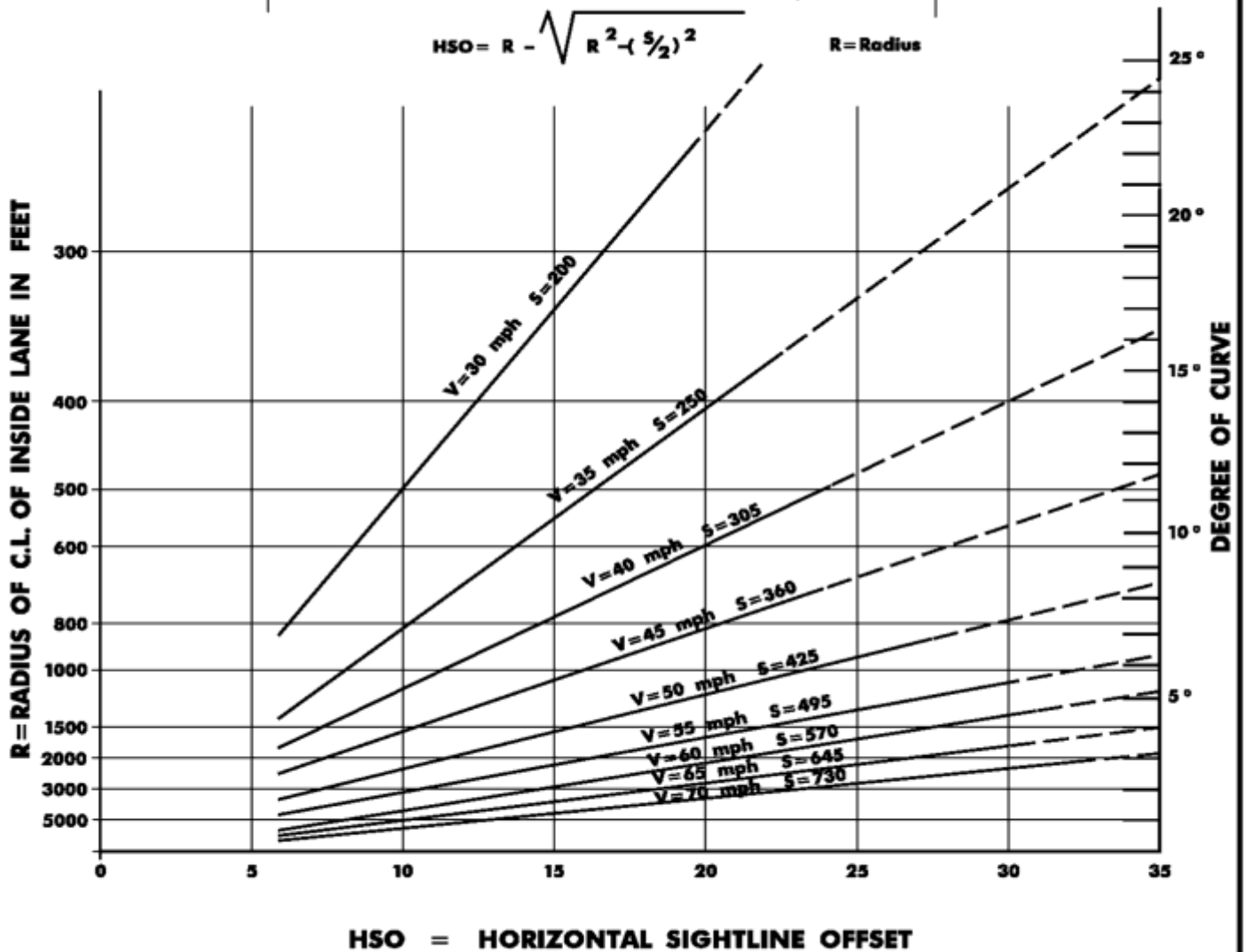

4.3 Horizontal Alignment

4.3.1 General

In the design of horizontal curves, it is necessary to establish the proper relationship between design speed, curvature and superelevation. Horizontal alignment must afford at least the minimum stopping sight distance for the design speed at all points on the roadway.

The major considerations in horizontal alignment design are: safety, grade, type of facility, design speed, topography and construction cost. In design, safety is always considered, either directly or indirectly. Topography controls both curve radius and design speed to a large extent. The design speed, in turn, controls sight distance, but sight distance must be considered concurrently with topography because it often demands a larger radius than the design speed. All these factors must be balanced to produce an alignment that is safe, economical, in harmony with the natural contour of the land and, at the same time, adequate for the design classification of the roadway or highway.

4.3.2 Superelevation

When a vehicle travels on a horizontal curve, it is forced radially outward by centrifugal force. This effect becomes more pronounced as the radius of the curve is shortened. This is counterbalanced by providing roadway superelevation and by the side friction between the vehicle tires and the surfacing. Safe travel at different speeds depends upon the radius of curvature, the side friction, and the rate of superelevation.

When the standard superelevation for a horizontal curve cannot be met, a design exception will be required. However, the highest practical superelevation should be selected for the horizontal curve design.

A 6 percent maximum superelevation rate shall be used on rural highways and rural or urban freeways (see Figure 4-B). A 4 percent maximum superelevation rate may be used on high speed urban highways to minimize conflicts with adjacent development and intersecting streets (see Figure 4-C). Low speed urban streets can use a 4 percent or 6 percent maximum superelevation rate (see Figure 4-C). The 6 percent maximum superelevation rate for low speed urban streets allows for:

1. a higher threshold of driver discomfort than the 6 percent superelevation rate in Figure 4-B, and
2. application with sharper curvature than the 4 percent maximum superelevation rate in Figure 4-C.

The minimum superelevation to be used is 1.5 percent on flat radius curves requiring superelevation ranging from 1.5 percent to 2.0 percent, the superelevation should be increased by 0.5 percent in each successive pair of lanes on the low side of the superelevation when more than two lanes are superelevated in the same direction.

Values of Superelevation for Rural Highways and Rural or Urban Freeways

FIGURE 4B

2004 AASHTO

BDC07MR-01

<i>e</i> (%)	<i>V_d</i> = 25 mph R(ft)	<i>V_d</i> = 30 mph R(ft)	<i>V_d</i> = 35 mph R(ft)	<i>V_d</i> = 40 mph R(ft)	<i>V_d</i> = 45 mph R(ft)	<i>V_d</i> = 50 mph R(ft)	<i>V_d</i> = 55 mph R(ft)	<i>V_d</i> = 60 mph R(ft)	<i>V_d</i> = 65 mph R(ft)	<i>V_d</i> = 70 mph R(ft)	<i>V_d</i> = 75 mph R(ft)
1.5	2290	3130	4100	5230	6480	7870	9410	11100	12600	14100	15700
2.0	1630	2240	2950	3770	4680	5700	6820	8060	9130	10300	11500
2.2	1450	2000	2630	3370	4190	5100	6110	7230	8200	9240	10400
2.4	1300	1790	2360	3030	3770	4600	5520	6540	7430	8380	9420
2.6	1170	1610	2130	2740	3420	4170	5020	5950	6770	7660	8620
2.8	1050	1460	1930	2490	3110	3800	4580	5440	6200	7030	7630
3.0	944	1320	1760	2270	2840	3480	4200	4990	5710	6490	7330
3.2	850	1200	1600	2080	2600	3200	3860	4600	5280	6010	6810
3.4	761	1080	1460	1900	2390	2940	3560	4250	4890	5580	6340
3.6	673	972	1320	1740	2190	2710	3290	3940	4540	5210	5930
3.8	583	864	1190	1590	2010	2490	3040	3650	4230	4860	5560
4.0	511	766	1070	1440	1840	2300	2810	3390	3950	4550	5220
4.2	452	684	960	1310	1680	2110	2590	3140	3630	4270	4910
4.4	402	615	868	1190	1540	1940	2400	2920	3440	4010	4630
4.6	360	555	788	1090	1410	1780	2210	2710	3220	3770	4380
4.8	324	502	718	995	1300	1640	2050	2510	3000	3550	4140
5.0	292	456	654	911	1190	1510	1890	2330	2800	3330	3910
5.2	264	413	595	833	1090	1390	1750	2160	2610	3120	3690
5.4	237	373	540	759	995	1280	1610	1990	2420	2910	3460
5.6	212	335	487	687	903	1160	1470	1830	2230	2700	3230
5.8	186	296	431	611	806	1040	1320	1650	2020	2460	2970
6.0	144	231	340	485	643	833	1060	1330	1660	2040	2500

Values of Superelevation for Urban Highways								FIGURE 4C
Note: Use of $e_{max} = 4\%$ should be limited to urban conditions. 2004 AASHTO								BDC07MR-01
e (%)	$V_{d=}$ 25mph <i>R (ft)</i>	$V_{d=}$ 30mph <i>R (ft)</i>	$V_{d=}$ 35mph <i>R (ft)</i>	$V_{d=}$ 40mph <i>R (ft)</i>	$V_{d=}$ 45mph <i>R (ft)</i>	$V_{d=}$ 50mph <i>R (ft)</i>	$V_{d=}$ 55mph <i>R (ft)</i>	$V_{d=}$ 60mph <i>R (ft)</i>
1.5	2050	2830	3730	4770	5930	7220	8650	10300
2.0	1340	1880	2490	3220	4040	4940	5950	7080
2.2	1110	1580	2120	2760	3480	4280	5180	6190
2.4	838	1270	1760	2340	2980	3690	4500	5410
2.6	650	1000	1420	1930	2490	3130	3870	4700
2.8	524	817	1170	1620	2100	2660	3310	4060
3.0	433	681	983	1370	1800	2290	2860	3530
3.2	363	576	835	1180	1550	1980	2490	3090
3.4	307	490	714	1010	1340	1720	2170	2700
3.6	259	416	610	865	1150	1480	1880	2350
3.8	215	348	512	730	970	1260	1600	2010
4.0	154	250	371	533	711	926	1190	1500

Values of Superelevation for Low-Speed Urban Streets				FIGURE 4C1	
<i>AASHTO 2004</i>				BDC07MR-01	
<i>e</i> (%)	<i>V_d</i> = 25mph <i>R</i> (ft)	<i>V_d</i> = 30mph <i>R</i> (ft)	<i>V_d</i> = 35mph <i>R</i> (ft)	<i>V_d</i> = 40mph <i>R</i> (ft)	<i>V_d</i> = 45mph <i>R</i> (ft)
-2.6	204	345	530	796	1089
-2.4	202	341	524	784	1071
-2.2	200	337	517	773	1055
-2.0	198	333	510	762	1039
-1.5	194	324	495	736	1000
0	181	300	454	667	900
1.5	170	279	419	610	818
2.0	167	273	408	593	794
2.2	165	270	404	586	785
2.4	164	268	400	580	776
2.6	163	265	396	573	767
2.8	161	263	393	567	758
3.0	160	261	389	561	750
3.2	159	259	385	556	742
3.4	158	256	382	550	734
3.6	157	254	378	544	726
3.8	155	252	375	539	718
4.0	154	250	371	533	711
4.2	153	248	368	528	703
4.4	152	246	365	523	696
4.6	151	244	361	518	689
4.8	150	242	358	513	682
5.0	149	240	355	508	675
5.2	148	238	352	503	668
5.4	147	236	349	498	662
5.6	146	234	346	494	655
5.8	145	233	343	489	649
6.0	144	231	340	485	643

- Notes: 1. Computed using Superelevation Distribution Method 2.
2. Superelevation may be optional on low-speed urban streets.
3. Negative superelevation values beyond -2.0% should be used for low type surfaces such as gravel, crushed stone, and earth. However, areas with intense rainfall may use normal cross slopes on high type surfaces of -2.5%.

It may be appropriate to provide adverse crown on flat radius curves (less than 2 percent superelevation) to avoid water buildup on the low side of the superelevation when there are more than three lanes draining across the pavement (This design treatment would require a design exception). Another option is to construct a permeable surface course or a high macrotexture surface course since these surfaces appear to have the highest potential for reducing hydroplaning accidents. Also, grooving the pavement perpendicular to the traveled way may be considered as a corrective measure for severe localized hydroplaning problems.

Figures 4-B and 4-C give the design values for each rate of superelevation to be used for various design speeds and radii on mainline curves.

A. Axis of Rotation

1. Undivided Highways

For undivided highways, the axis of rotation for superelevation is usually the centerline of the traveled way. However, in special cases where curves are preceded by long, relatively level tangents, the plane of superelevation may be rotated about the inside edge of the pavement to improve perception of the curve. In flat terrain, drainage pockets caused by superelevation may be avoided by changing the axis of rotation from the centerline to the inside edge of the pavement.

2. Ramps and Freeway to Freeway Connections

The axis of rotation may be about either edge of pavement or centerline if multi-lane. Appearance and drainage considerations should always be taken into account in selection of the axis rotation.

3. Divided Highways

a. Freeways

Where the initial median width is 30 feet or less, the axis of rotation should be at the median centerline.

Where the initial median width is greater than 30 feet and the ultimate median width is 30 feet or less, the axis of rotation should be at the median centerline, except where the resulting initial median slope would be steeper than 10H:1V. In the latter case, the axis of rotation should be at the ultimate median edges of pavement.

Where the ultimate median width is greater than 30 feet, the axis of rotation should be at the proposed median edges of pavement.

Where the initial median width is 30 feet or less, the axis of rotation should be at the median centerline.

Where the initial median width is greater than 30 feet and the ultimate median width is 30 feet or less, the axis of rotation should be at the median centerline, except where the resulting initial median slope would be steeper than 10H:1V. In the latter case, the axis of rotation should be at the ultimate median edges of pavement.

Where the ultimate median width is greater than 30 feet, the axis of rotation should be at the proposed median edges of pavement.

To avoid a sawtooth on bridges with decked medians, the axis of rotation, if not already on the median centerline, should be shifted to the median centerline.

b. Other Divided Highways

The axis of rotation should be considered on an individual project basis and the most appropriate case for the conditions should be selected.

The selection of the axis of rotation should always be considered in conjunction with the design of the profile and superelevation transition.

B. Superelevation Transition

The superelevation transition consists of the superelevation runoff (length of roadway needed to accomplish the change in outside-lane cross slope from zero to full superelevation or vice versa) and tangent runout (length of roadway needed to accomplish the change in outside-lane cross slope from the normal cross slope to zero or vice versa). The definition of and method of deriving superelevation runoff and runout in this manual is the same as described in AASHTO, "A Policy on Geometric Design of Highways and Streets."

The superelevation transition should be designed to satisfy the requirements of safety and comfort and be pleasing in appearance. The minimum length of superelevation runoff and runout should be based on the following formula:

Superelevation Runoff

$$L_r = (w)(n)(e)(b)/\Delta$$

Where:

- L_r = minimum length of superelevation runoff, ft;
- Δ = maximum relative gradient, percent (Table 4-2);
- n = number of lanes rotated
- b = adjustment factor for number of lanes rotated (Table 4-3)
- w = width of one traffic lane, ft.
- e = design superelevation rate, percent

Tangent Runout

$$L_t = (L_r)(e_{NC})/e$$

Where

- L_t = minimum length of tangent runout, ft.
- e_{NC} = normal cross slope rate, percent
- e = design superelevation rate
- L_r = minimum length of superelevation runoff, ft.

Table 4-2
Maximum Relative Gradient

Design Speed (mph)	25	30	35	40	45	50	55	60	65	70
Maximum Relative Gradient	0.70	0.66	0.62	0.58	0.54	0.50	0.47	0.45	0.43	0.40

**Table 4-3
Adjustment Factor for Number of Lanes Rotated**

Number of Lanes Rotated (n)	Adjustment Factor (b)
1	1.00
1.5	0.83
2	0.75
2.5	0.70
3	0.67
3.5	0.64

On 3R projects where the existing runoff and runout lengths are shorter than calculated from the formula, the existing runoff and runout lengths may be maintained.

With respect to the beginning or ending of a curve, the amount of runoff on the tangent should desirably be based on Table 4-4. However, runoff lengths on the tangent ranging from 60 to 90 percent are acceptable.

**Table 4-4
Percent of Runoff on Tangent**

Design Speed Mph	Portion of runoff located prior to the curve			
	Number of lanes rotated			
	1.0	1.5	2.0-2.5	3.0-3.5
25-45	0.80	0.85	0.90	0.90
50-80	0.70	0.75	0.80	0.85

After a superelevation transition is designed, profiles of the edges of pavement and shoulder should be plotted and irregularities removed by introducing smooth curves by the means of a graphic profile. Flat areas which are undesirable from a drainage standpoint should be avoided.

Pronounced and unsightly sags may develop on the low side of the superelevation. These can be corrected by adjusting the grades on the two edges of pavement throughout the curve.

C. Transition Curves and Superelevation

The use of transition curves on arterial highways designed for 50 mph or greater is encouraged. Figures 4D through 4H inclusive indicate the desirable treatment on highway curves including the method of distributing superelevation.

TRANSITION CURVES

FIGURE: 4-D

BDC07MR-01

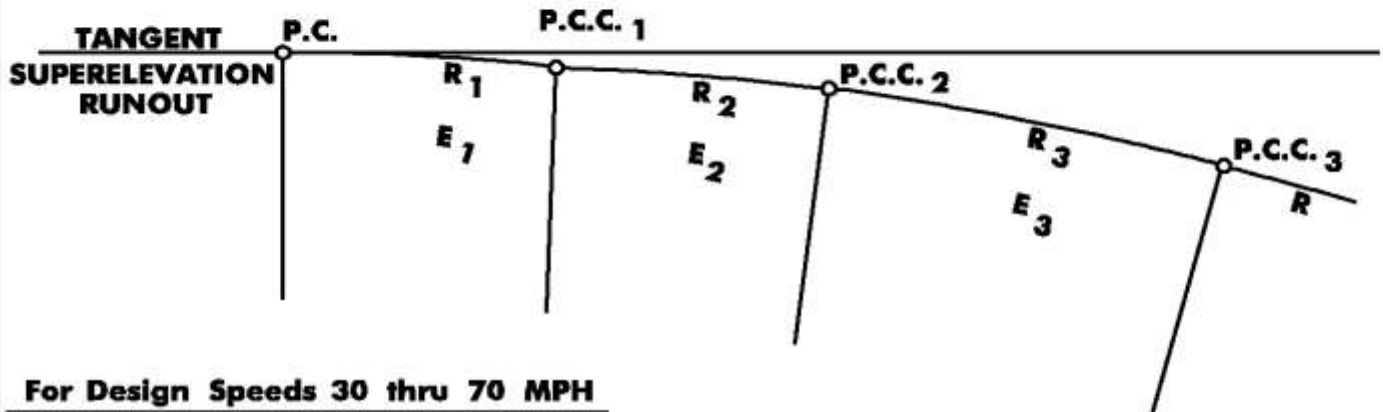

For Design Speeds 30 thru 70 MPH

1. Determine if radii transition is needed for radius R using chart below. Transition curves not essential when radius is greater than:

Superelevation	30 MPH	35 MPH	40 MPH	45 MPH	50 MPH	55 MPH	60 MPH	70 MPH
6% Superelevation for rural hways & rural or urban fwys	1400	2100	2900	3300	3800	4800	5700	7600
4% Superelevation for urban highways	1000	1300	1600	2300	2900	3300	3800	NA

2. If required, use standard Transition Curves.
3. At P.C.C.₃ hold maximum E for radius R.
4. Using superelevation chart, determine if superelevation is needed for R₁.
5. If superelevation is needed for R₁, use 2/3 maximum superelevation for R₁ at P.C.
6. Distribute superelevation evenly between P.C.C.₃ and P.C.
7. Distribute superelevation at the same rate as in step 6 on tangent up to normal section. However, this superelevation transition may be reduced to 2%/sec. in certain locations, such as on short tangents between reverse curves or on a crest or sag vertical curve.

On Existing Roadways Or Where Radii Transitions Can Not Be Provided

1. Determine maximum superelevation needed for radius (R).
2. Use 2/3 maximum superelevation at P.C. and P.T. of curve.
3. Distribute superelevation at a maximum rate of 2%/sec.

TRANSITION CURVES

FIGURE: 4-E

BDC07MR-01

1,000' TO 1,600' RADIUS

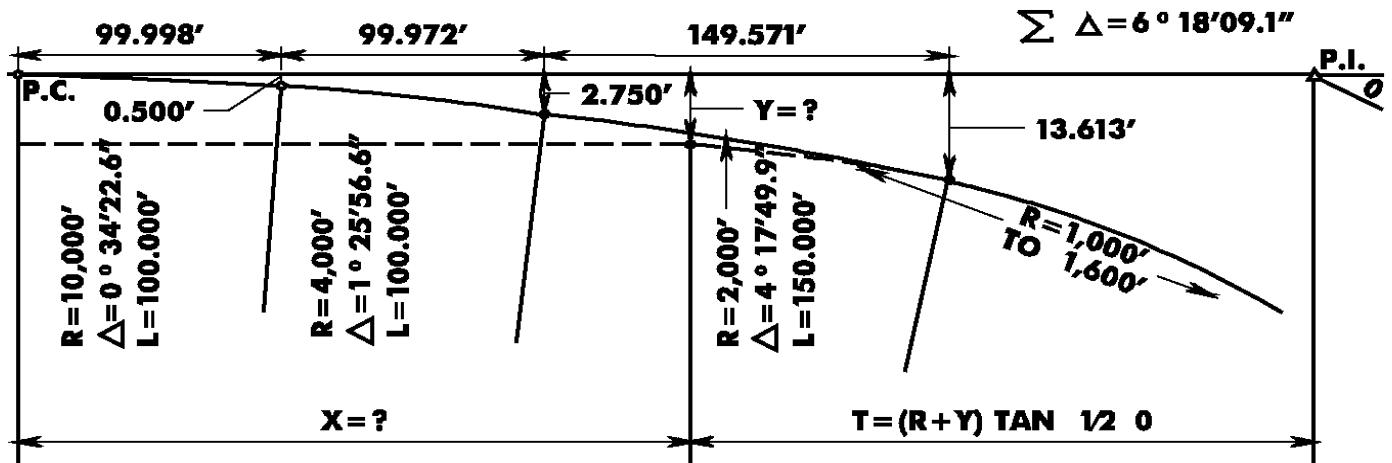

$$X = 349.5413 - 0.1097783008 R$$

$$Y = 13.6127 - 0.0060439020 R$$

1,600' TO 1,800' RADIUS

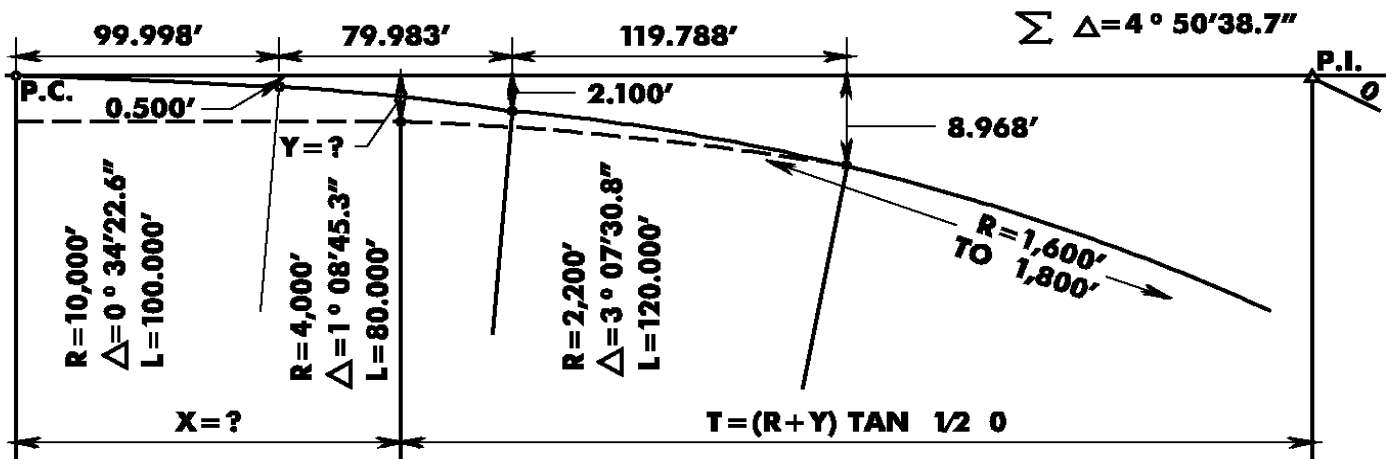

$$X = 299.7694 - 0.0844447697 R$$

$$Y = 8.9680 - 0.0035718386 R$$

NOTE: To Locate Transition P.C.:

- (1) Find X and Y for desired radius
- (2) Add radius R to Y distance
- (3) Find T for R and Y
- (4) Add T to X for distance P.C. to P.I.

TRANSITION CURVES

FIGURE: 4-F

BDC07MR-01

1,800' TO 2,200' RADIUS

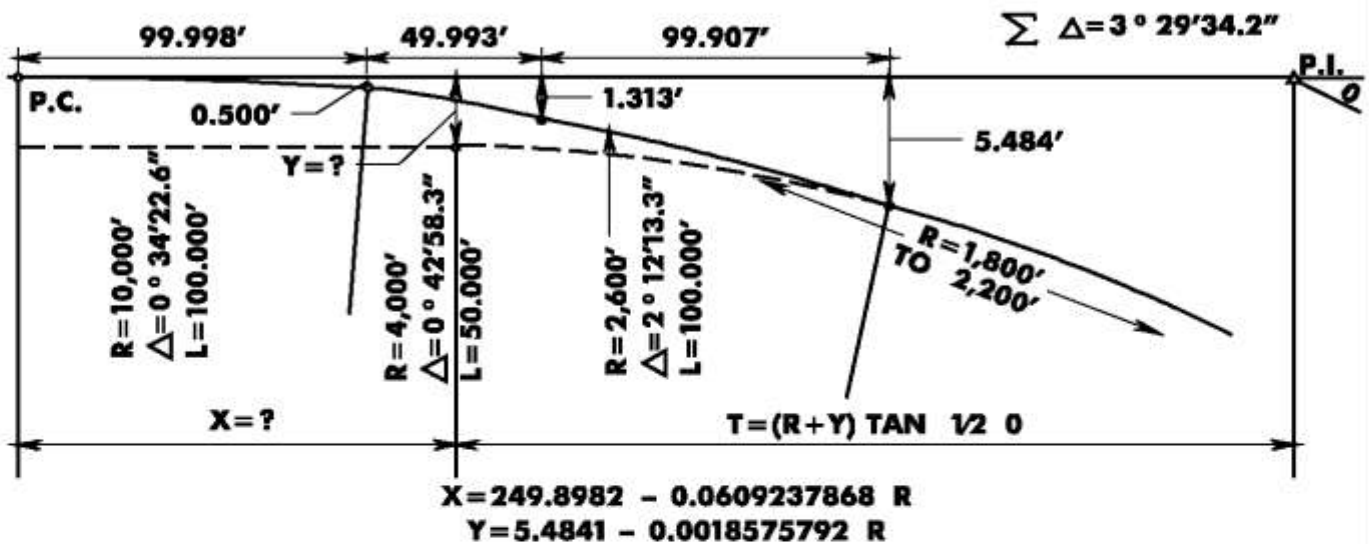

2,200' TO 3,000' RADIUS

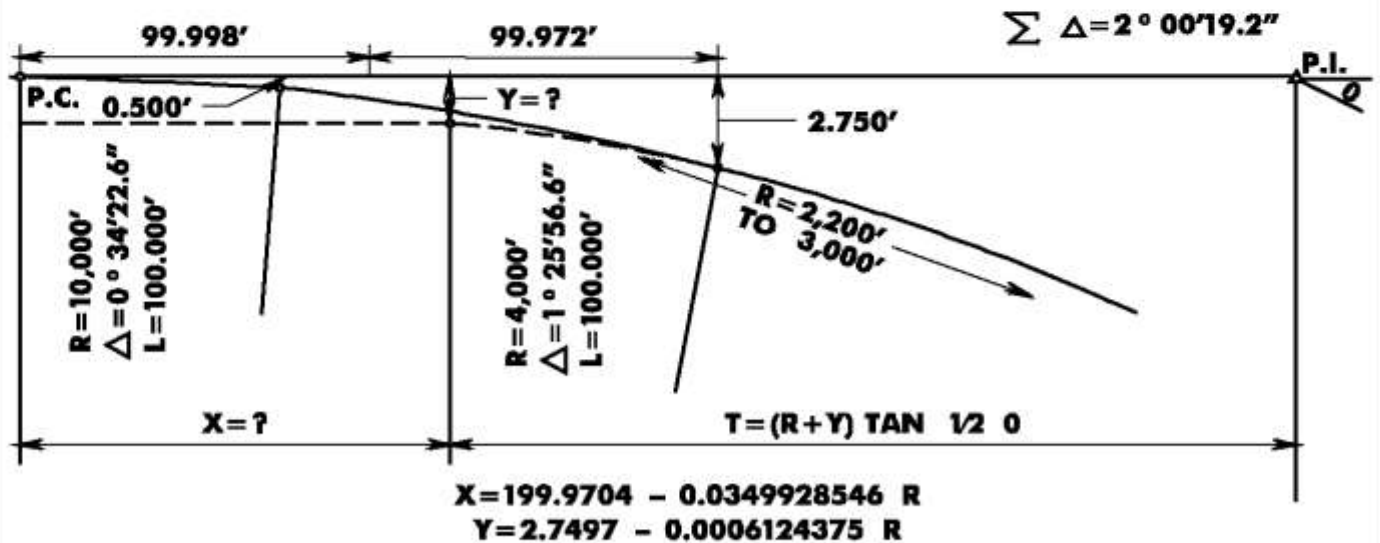

NOTE: To Locate Transition P.C.:

- (1) Find X and Y for desired radius
- (2) Add radius R to Y distance
- (3) Find T for R and Y
- (4) Add T to X for distance P.C. to P.I.

TRANSITION CURVES

FIGURE: 4-G

BDC07MR-01

3,500' TO 4,500' RADIUS

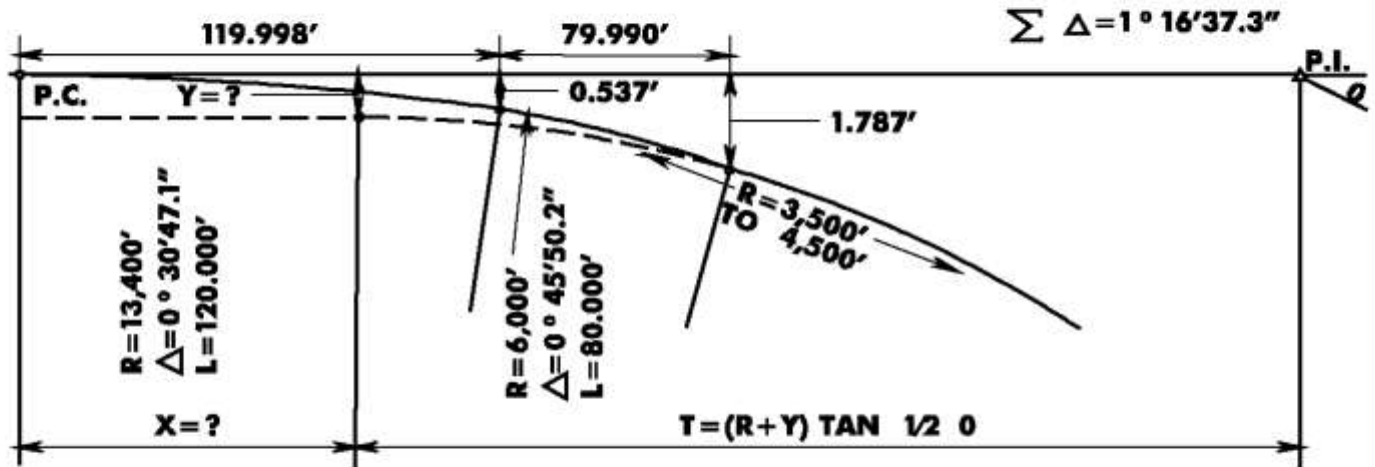

$$X = 199.9880 - 0.0222867118 R$$

$$Y = 1.7870 - 0.0002483796 R$$

3,000' TO 3,500' RADIUS

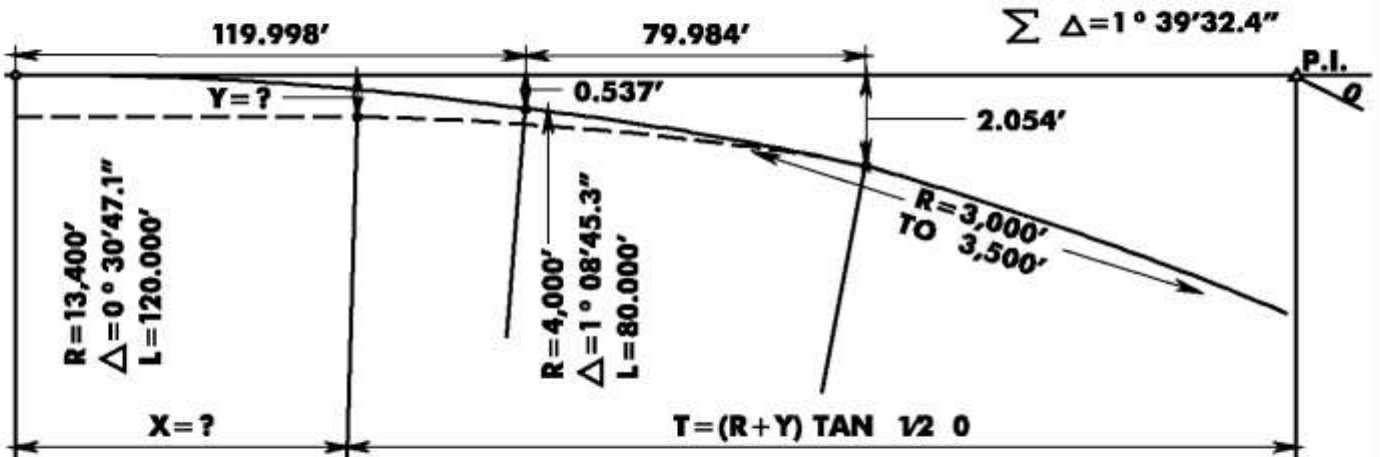

$$X = 199.9827 - 0.0289511780 R$$

$$Y = 2.0536 - 0.0004191732 R$$

NOTE: To Locate Transition P.C.:

- (1) Find X and Y for desired radius
- (2) Add radius R to Y distance
- (3) Find T for R and Y
- (4) Add T to X for distance P.C. to P.I.

TRANSITION CURVES

FIGURE: 4-H

BDC07MR-01

4,500' TO 6,000' RADIUS

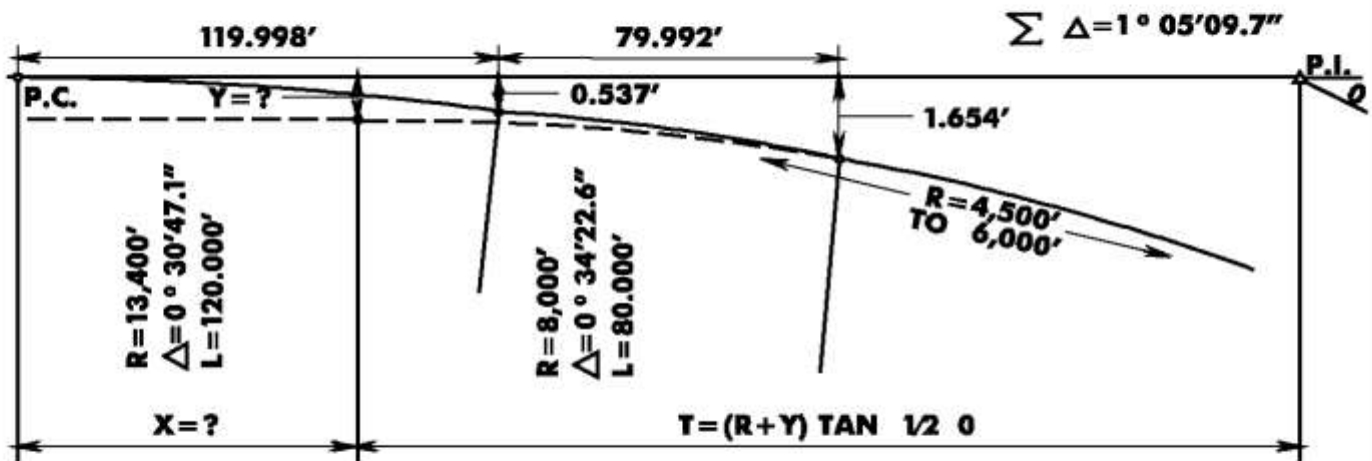

$$X = 199.9903 - 0.0189540888 R$$

$$Y = 1.6537 - 0.0001796449 R$$

6,000' TO 8,000' RADIUS

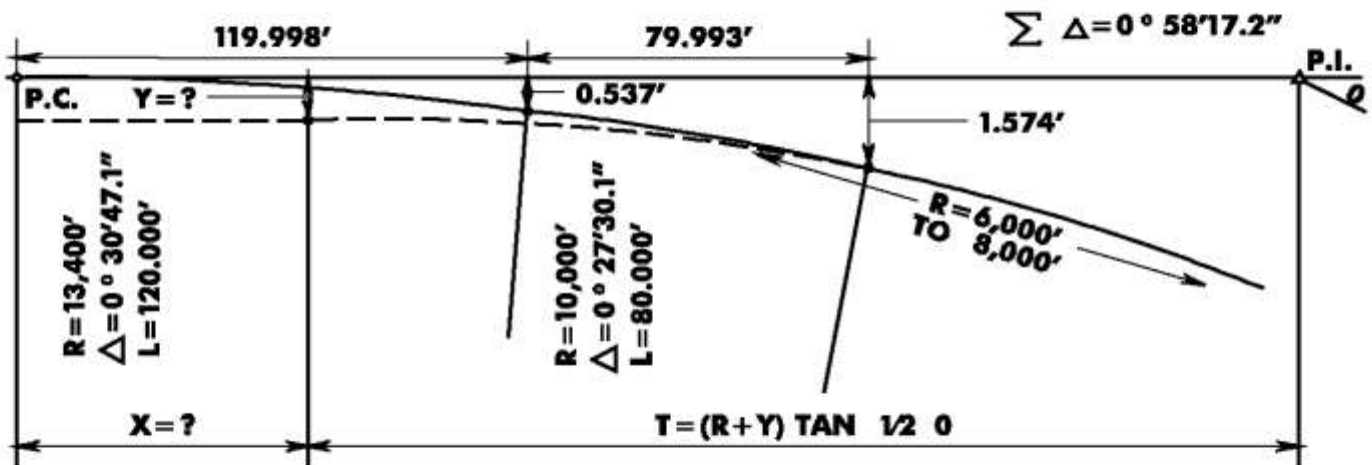

$$X = 199.9915 - 0.0169544115 R$$

$$Y = 1.5737 - 0.0001437364 R$$

NOTE: To Locate Transition P.C.:

- (1) Find X and Y for desired radius
- (2) Add radius R to Y distance
- (3) Find T for R and Y
- (4) Add T to X for distance P.C. to P.I.

4.3.3 Curvature

A General

The changes in direction along a highway are basically accounted for by simple curves or compound curves. Excessive curvature or poor combinations of curvature generate accidents, limit capacity, cause economic losses in time and operating costs, and detract from a pleasing appearance. To avoid these poor design practices, the following general controls should be used.

B. Curve Radii for Horizontal Curves

Table 4-5 gives the minimum radius of open highway curves for specific design speeds. This table is based upon a 6 percent and 4 percent maximum superelevation; it ignores the horizontal stopping sight distance factor.

**Table 4-5
Standards for Curve Radius**

Design Speed (mph)	Minimum Radius of Curve for Rural Highways and Rural or Urban Freeways Based on 6% e_{max}	Minimum Radius of Curve for Urban Highways Based on 4% e_{max}	Minimum Radius of Curve for Low Speed Urban Highways Based on 6% e_{max}
	(ft)	(ft)	(ft)
25	144	154	144
30	231	250	231
35	340	371	340
40	485	533	485
45	643	711	---
50	833	926	---
55	1060	1190	---
60	1330	1500	---
65	1660	---	---
70	2040	---	---

Every effort should be made to exceed the minimum values. Minimum radii should be used only when the cost or other adverse effects of realizing a higher standard are inconsistent with the benefits. Where a longitudinal barrier is provided in the median, the above minimum radii may need to be increased or the adjacent shoulder widened to provide adequate horizontal stopping sight distance.

The suggested minimum radius for a freeway is 3000 feet in rural areas and 1600 feet in urban areas. For a land service highway, the preferred minimum radius is 1600 feet and 1000 feet for design speeds of 60 mph and 50 mph respectively.

Due to the higher center of gravity on large trucks, sharp curves on open highways may contribute to truck overturning. Overturning becomes critical on radii below approximately 700 feet. Where new or reconstructed curves on open highways with radii less than 700

feet must be provided, the design of these radii shall be based upon a design speed of at least 10 mph greater than the anticipated posted speed.

C. Alignment Consistency

Sudden reductions in standards introduce the element of surprise to the driver and should be avoided. Where physical restrictions on curve radius cannot be overcome and it becomes necessary to introduce curvature of a lower standard than the design speed for the project, the design speed between successive curves shall change not more than 10 mph. Introduction of a curve for a design speed lower than the design speed of the project shall be avoided at the end of a long tangent or at other locations where high approach speeds may be anticipated.

D. Stopping Sight Distance

Horizontal alignment should afford at least the desirable stopping sight distance for the design speed at all points of the highway. Where social, environmental or economic impacts do not permit the use of desirable values, lesser stopping sight distances may be used, but shall not be less than the minimum values.

E. Curve Length and Central Angle

The following is applicable for freeways and rural arterial highways. Desirably, the minimum curve length for central angles less than 5 degrees should be 500 feet long, and the minimum length should be increased 100 feet for each 1 degree decrease in the central angle to avoid the appearance of a kink. For central angles smaller than 30 minutes, no curve is required. In no event shall sight distance or other safety considerations be sacrificed to meet the above requirement.

F. Compound Curves

On compound curves for arterial highways, the curve treatment shown in Figures 4D through 4H should be used. For compound curves at intersections and ramps, the ratio of the flatter radius to the sharper radius should not exceed 2.0.

G. Reversing Curves

The intervening tangent distance between reverse curves should, as a minimum, be sufficient to accommodate the superelevation transition as specified in Section 4.3.2, "Superelevation." For design speeds of 50 mph and greater, longer tangent lengths are desirable. A range of desirable tangent lengths are shown in Table 4-6 for high design speeds.

**Table 4-6
Desirable Tangent Length
Between Reversing Curves**

Design Speed (mph)	Desirable Tangent (ft)
50	500-600
60	600-800
70	800-1000

H. Broken Back Curves

A broken back curve consists of two curves in the same direction joined by a short tangent. Broken back curves are unsightly and violate driver expectancy. A reasonable additional expenditure may be warranted to avoid such curvature.

The intervening tangent distance between broken back curves should, as a minimum, be sufficient to accommodate the superelevation transition as specified in Section 4.3.2. For design speeds of 50 mph and greater, longer tangent lengths are desirable. Table 4-7 indicates the desirable tangent length between same direction curves. The desirable tangent distance should be exceeded when both curves are visible for some distance ahead.

**Table 4-7
Desirable Tangent Length
Between Same Direction Curves**

Design Speed (mph)	Desirable Tangent (ft)
50	1000
60	1500
70	2500

I. Alignment at Bridges

Superelevation transitions on bridges almost always result in an unsightly appearance of the bridge and the bridge railing. Therefore, if at all possible, horizontal curves should begin and end a sufficient distance from the bridge so that no part of the superelevation transition extends onto the bridge. Alignment and safety considerations, however, are paramount and shall not be sacrificed to meet the above criteria.

4.4 Vertical Alignment

4.4.1 General

The profile line is a reference line by which the elevation of the pavement and other features of the highway are established. It is controlled mainly by topography, type of highway, horizontal alignment, safety, sight distance, construction costs, cultural development, drainage and pleasing appearance. The performance of heavy vehicles on a grade must also be considered.

All portions of the profile line must meet sight distance requirements for the design speed of the road.

In flat terrain, the elevation of the profile line is often controlled by drainage considerations. In rolling terrain, some undulation in the profile line is often advantageous, both from the standpoint of truck operation and construction economy. But, this should be done with appearance in mind; for example, a profile on tangent alignment exhibiting a series of humps visible for some distance ahead should be avoided whenever possible. In rolling terrain, however, the profile usually is closely dependent upon physical controls.

In considering alternative profiles, economic comparisons should be made. For further details, see AASHTO, *"A Policy on Geometric Design of Highways and Streets."*

4.4.2 Position with Respect to Cross Section

The profile line should generally coincide with the axis of rotation for superelevation. The relation to the cross section should be as follows:

A. Undivided Highways

The profile line should coincide with the highway centerline.

B. Ramps and Freeway to Freeway Connections

The profile line may be positioned at either edge of pavement, or centerline of ramp if multi-lane.

C. Divided Highways

The profile line may be positioned at either the centerline of the median or at the median edge of pavement. The former case is appropriate for paved medians 30 feet wide or less. The latter case is appropriate when:

1. The median edges of pavement of the two roadways are at equal elevation.
2. The two roadways are at different elevations.

4.4.3 Separate Grade Lines

Separate or independent profile lines are appropriate in some cases for freeways and divided arterial highways.

They are not normally considered appropriate where medians are less than 30 feet. Exceptions to this may be minor differences between opposing grade lines in special situations.

In addition, appreciable grade differentials between roadbeds should be avoided in the vicinity of at-grade intersections. For traffic entering from the crossroad, confusion and wrong-way movements could result if the pavement of the far roadway is obscured due to an excessive differential.

4.4.4 Standards for Grade

The minimum grade rate for freeways and land service highways with a curbed or bermed section is 0.3 percent. On highways with an umbrella section, grades flatter than 0.3 percent may be used where the shoulder width is 8 feet or greater and the shoulder cross slope is 4 percent or greater. For maximum grades for urban and rural land service highways and freeways, see Table 4-8.

**Table 4-8
Maximum Grades (%)**

Rural Land Service Highways

Type of Terrain	Design Speed (mph)						
	30	40	45	50	55	60	65
Level	---	5	5	4	4	3	3
Rolling	---	6	6	5	5	4	4
Mountainous	---	8	7	7	6	6	5

Urban Land Service Highways

Type of Terrain	Design Speed (mph)						
	30	40	45	50	55	60	65
Level	8	7	6	6	5	5	---
Rolling	9	8	7	7	6	6	---
Mountainous	11	10	9	9	8	8	---

Freeways *

Type of Terrain	Design Speed (mph)						
	40	45	50	55	60	65	70
Level	---	---	4	4	3	3	3
Rolling	---	---	5	5	4	4	4
Mountainous	---	---	6	6	6	5	5

* Grades 1% steeper than the value shown may be provided in mountainous terrain or in urban areas with crucial right-of-way controls.

4.4.5 Vertical Curves

Properly designed vertical curves should provide adequate sight distance, safety, comfortable driving, good drainage, and pleasing appearance. On new alignments or major reconstruction projects on existing highways, the designer should, where practical, provide the desirable vertical curve lengths. The use of minimum vertical curve lengths should be limited to existing highways and those locations where the desirable values or values greater than the minimum would involve significant social, environmental or economic impacts.

A parabolic vertical curve is used to provide a smooth transition between different tangent grades. Figures 4-I and 4-J give the length of crest and sag vertical curves for various design speeds and algebraic differences in grade. The stopping sight distance for these curves are based upon a height of eye of 3.5 feet, and a height of object of 2 feet. The minimum length of vertical curve may also be obtained by multiplying the K value (Fig. 4-I or 4-J) by the algebraic difference in grade. The vertical lines in Figure 4-I and 4-J are equivalent to 3 times the design speed. To determine the length of crest vertical curves on highways designed with two-way left-turn lanes (see Section 6.7.1).

Flat vertical curves may develop poor drainage at level sections. Highway drainage must be given more careful consideration when the design speed exceeds 60 and 65 mph for crest vertical curves and sag vertical curves respectively. The length of sag vertical curves for riding comfort should desirably be approximately equal to:

$$L = AV^2/46.5.$$

L = Length of sag vertical curve, ft.

A = Algebraic difference in grades, percent.

V = Design speed, mph.

When the difference between the P.V.I. elevation and the vertical curve elevation at the P.V.I. station (E) is 0.0625 feet (3/4 inch), a vertical curve is not required. The use of a profile angle point is permitted. The maximum algebraic difference in tangent grades (A) that an angle point is permitted for various design speeds is shown in Table 4-9. This table is based on a length of vertical curve of 3 times the design speed.

**Table 4-9
Use of a Profile Angle Point**

Design Speed (mph)	A_{MAX} %
25	.70
30	.55
35	.50
40	.40
45	.40
50	.35
55	.30
60	.30
65	.25
70	.25

All umbrella section low points in cut and fill sections on freeways and Interstate highways shall be provided with slope protection at each low point in the mainline or ramp vertical geometry as shown in the "*Standard Roadway Construction Details*." The purpose of this treatment is to minimize maintenance requirements in addressing the gradual build up of a berm which may eventually contribute to water ponding on the roadway surface and/or erosion of the side slope. The following are some recommended low point treatments:

A. Low Point at Edge of Ramp or Outside Edge of Mainline Pavement

Where practical, an "E" inlet should be provided in the outside edge of pavement at the low point to catch and divert the surface runoff. Provide outlet protection where needed at the pipe outfall.

As an alternative, provide slope protection which shall consist of the following:

1. Fill Section

Slope protection shall consist of a 20 feet long bituminous concrete paved area between the edge of pavement and the hinge point (PVI) together with a riprap stone flume on the fill slope and a riprap stone apron at the bottom of the slope. The riprap shall only be provided where the fill slope is steeper than 4H:1V. Where there is an inlet in a swale at the low point, center the riprap stone apron around the inlet. Where guide rail exists at the low point, the 10 foot long paved area shall be constructed instead of the non-vegetative surface treatment under the guide rail.

2. Cut Section

Slope protection shall consist of a 20 foot long bituminous concrete paved area between the edge of pavement and the toe of slope.

3. Low Point at Median Edge of Mainline Pavement

Provide slope protection which shall consist of a 20 foot long by 5 foot wide strip of bituminous concrete pavement adjacent to the inside edge of shoulder. If the fill slope is steeper than 4H:1V, provide riprap stone slope protection as described in "Low Point at Edge of Ramp or Outside Edge of Mainline Pavement".

On two-lane roads, extremely long crest vertical curves over one half mile should be avoided, since many drivers refuse to pass on such curves, despite adequate sight distance. It is sometimes more economical to use four-lane construction, than to obtain passing sight distance by the use of a long vertical curve.

Vertical curves affect intersection sight distance, therefore, utilizing the distances in Figure 6-A, an eye height of 3.5 feet and an object height of 3.5 feet; check for vertical sight distance at the intersection.

Broken back vertical curves consist of two vertical curves in the same direction, separated by a short grade tangent. A profile with such curvature normally should be avoided.

4.4.6 Heavy Grades

Except on level terrain, often it is not economically feasible to design a profile that will allow uniform operating speeds for all classes of vehicles. Sometimes, a long sustained gradient is unavoidable.

From a truck operation standpoint, a profile with sections of maximum gradient broken by length of flatter grade is preferable to a long sustained grade only slightly below the maximum allowable. It is considered good practice to use the steeper rates at the bottom of the grade, thus developing slack for lighter gradient at the top or elsewhere on the grade.

4.4.7 Coordination with Horizontal Alignment

A proper balance between curvature and grades should be sought. When possible, vertical curves should be superimposed on horizontal curves. This reduces the number of sight distance restrictions on the project, makes changes in profile less apparent, particularly in rolling terrain, and results in a pleasing appearance. For safety reasons, the horizontal curve should lead the vertical curve. On the other hand, where the change in horizontal alignment at a grade summit is slight, it safely may be concealed by making the vertical curve overlay the horizontal curve.

When vertical and horizontal curves are thus superimposed, the superelevation may cause distortion in the outer pavement edges. Profiles of the pavement edge should be plotted and smooth curves introduced to remove any irregularities.

A sharp horizontal curve should not be introduced at or near a pronounced summit or grade sag. This presents a distorted appearance and is particularly hazardous at night.

DESIGN CONTROLS FOR CREST VERTICAL CURVES

FIGURE: 4-1
BDC07MR-01

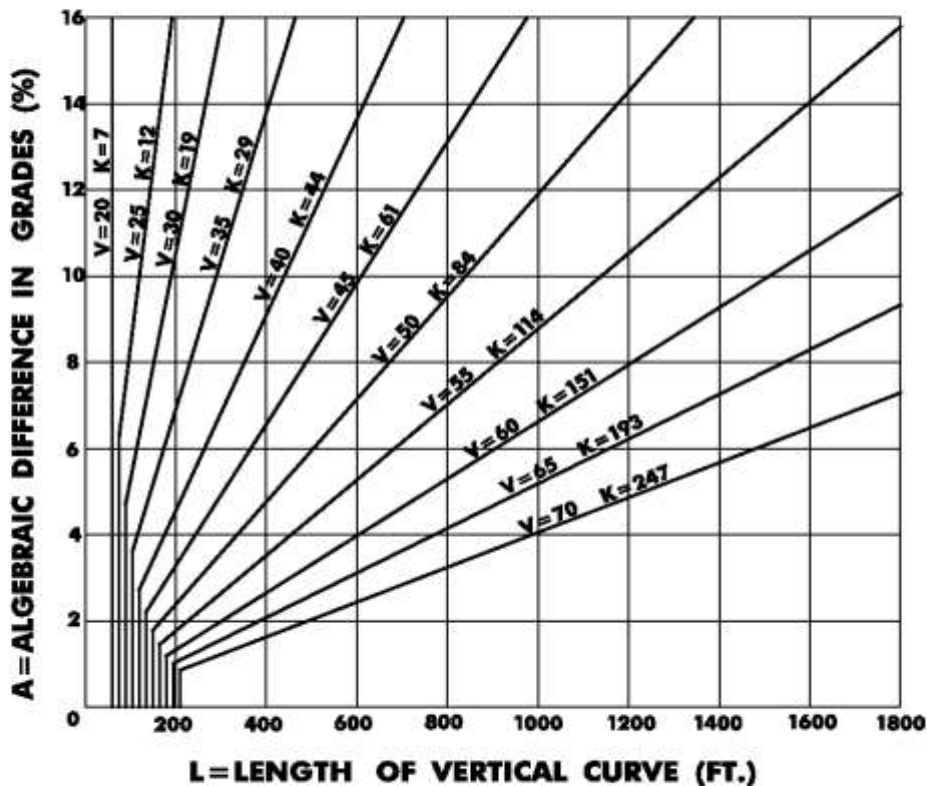

NOTE: Drainage of the Roadway on CREST Vertical Curves must be more carefully designed when the Design Speed exceeds 60 MPH.

When S is greater than L, $L = 2S - \frac{2158}{A}$

When S is less than L, $L = \frac{AS^2}{2158}$

V = Design Speed

S = Stopping Sight Distance, Feet

A = Algebraic Difference In Tangent Grades, Percent

K = Horizontal Distance Required To Effect A Percent Change In Gradient, Feet

L = KA

DESIGN CONTROLS FOR SAG VERTICAL CURVES

FIGURE: 4-J

BDC07MR-01

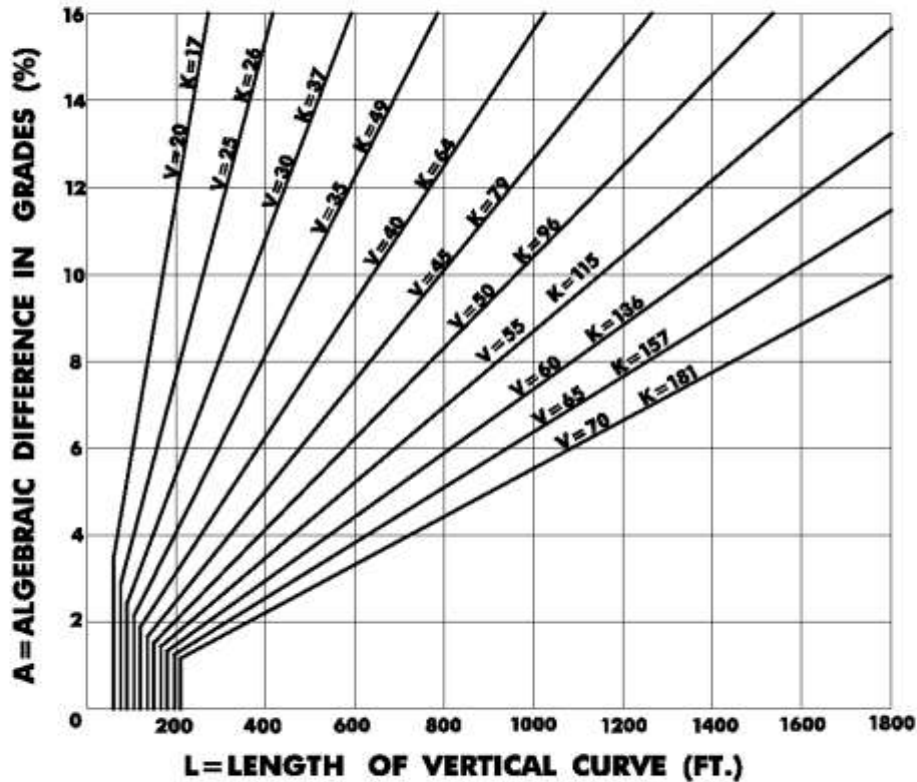

NOTE: Drainage of the Roadway on SAG Vertical Curves must be more carefully designed when the Design Speed exceeds 65 MPH.

When S is greater than L, $L = 2S - \frac{400 + 3.5S}{A}$

When S is less than L, $L = \frac{AS^2}{400 + 3.5S}$

V = Design Speed

S = Light Beam Distance, Feet

A = Algebraic Difference In Tangent Grades, Percent

K = Horizontal Distance Required To Effect A Percent Change In Gradient, Feet

L = KA

4.5 Climbing Lane

A climbing lane, as shown in Figure 4-K, is an auxiliary lane introduced at the beginning of a sustained positive grade for the diversion of slow traffic.

Generally, climbing lanes will be provided when the following conditions are satisfied. These conditions could be waived if slower moving truck traffic was the major contributing factor causing a high accident rate and could be corrected by addition of a climbing lane.

A. Two-Lane Highways

The following three conditions should be satisfied to justify a climbing lane:

1. Upgrade traffic flow rate in excess of 200 vehicles per hour.
2. Upgrade truck flow rate in excess of 20 vehicles per hour.
3. **One** of the following conditions exists:
 - a. A 10 mph or greater speed reduction is expected for a typical heavy truck.
 - b. Level of Service E or F exists on the grade.
 - c. A reduction of two or more levels of service is experienced when moving from the approach segment of the grade.

A complete explanation and a sample calculation on how to check for these conditions are shown in the section on "Climbing Lanes" contained in Chapter 3, "Elements of Design", of the AASHTO, *"A Policy on Geometric Design of Highways and Streets."*

B. Freeways and Multi-lane Highways

Both of the following conditions should be satisfied to justify a climbing lane:

1. A 10 mph or greater speed reduction is expected for a typical heavy truck.
2. The service volume on an individual grade should not exceed that attained by using the next poorer level of service from that used for the basic design. The one exception is that the service volume derived from employing Level of Service D should not be exceeded.

If the analysis indicates that a climbing lane is required, an additional check must be made to determine if the number of lanes required on the grade are sufficient even with a climbing lane.

A complete explanation and a sample calculation on how to check for these conditions are shown in the section on "Climbing Lanes" contained in Chapter 3, "Elements of Design", of the AASHTO, *"A Policy on Geometric Design of Highways and Streets."*

The beginning warrant for a truck climbing lane shall be that point where truck operating speed is reduced by 10 mph. To locate this point, use Exhibit 3-59 or Exhibit 3-60 of the aforementioned AASHTO Policy, depending on the weight/horsepower ratio of the appropriate truck. The beginning of the climbing lane should be preceded by a tapered section, desirably 300 feet, however, a 150 feet minimum taper may be used.

Desirably, the point of ending of a climbing lane would be to a point beyond the crest, where a typical truck could attain a speed that is about 10 mph below the operating speed of the highway. This point can be determined from Exhibit 3-60 of the aforementioned AASHTO Policy. If it is not practical to end the climbing lane as per Exhibit 3-60, end the climbing lane at a point where the truck has proper sight distance to safely merge into the normal lane, or preferably, 200 feet beyond this point. For two lane highways, passing sight distance should be available. For freeways and multi-lane highways, passing sight

distance need not be considered. For all highways, as a minimum, stopping sight distance shall be available. The ending taper beyond this point shall be according to Figure 4-L.

A distance-speed profile should be developed for the area of a climbing lane. The profile should start at the bottom of the first long downgrade prior to the upgrade being considered for a climbing lane, speeds through long vertical curves can be approximated by considering 25 percent of the vertical curve length (chord) as part of the grade under question.

CLIMBING LANE

FIGURE: 4-K

BDC07MR-01

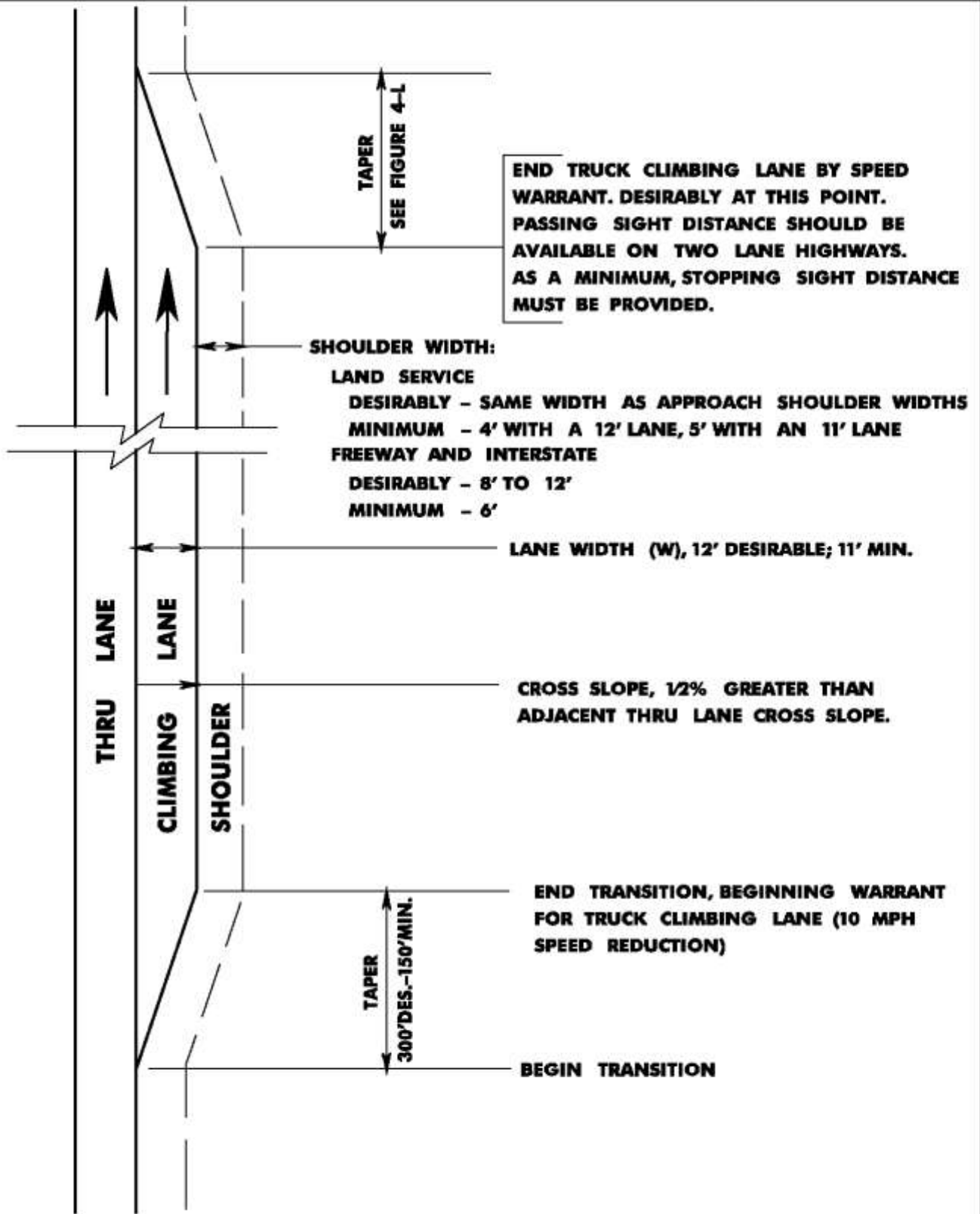

4.6 Through Lane Transition

Design standards of the various features of the transition between roadways of different widths should be consistent with the design standards of the superior roadway. The transition for a lane drop or lane width reduction should be made on a tangent section whenever possible and should avoid locations with horizontal and vertical sight distance restrictions. Whenever feasible, the entire transition should be visible to the driver of a vehicle approaching the narrower section.

The design should be such that at grade intersections within the transition are avoided.

Figure 4-L shows the minimum required taper length based upon the design speed of the roadway. In all cases, a taper length longer than the minimum should be provided where possible. In general, when a lane is dropped by tapering, the transition should be on the right so that traffic merges to the left.

THROUGH LANE TRANSITION

FIGURE: 4-L

BDC12MR-01

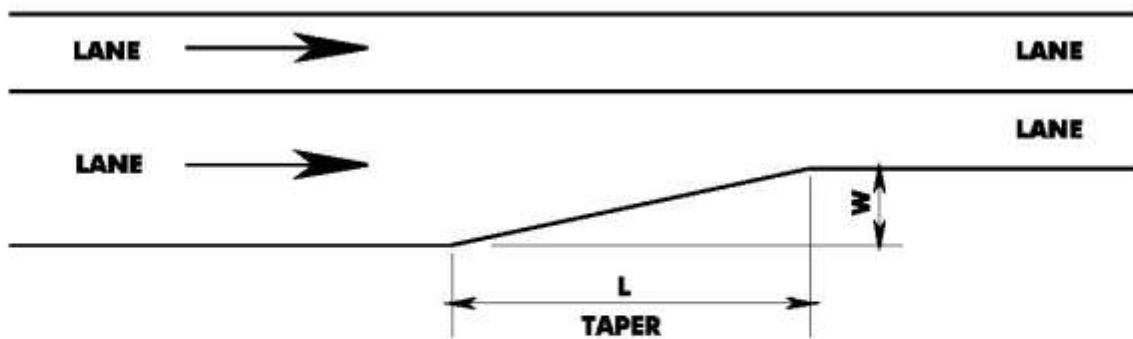

FOR DESIGN SPEEDS GREATER THAN
45 MPH, $L = VW$.

$V =$ DESIGN SPEED (MPH)
 $W =$ LANE WIDTH REDUCTION (FT.)
 $L =$ TAPER LENGTH (FT.)

FOR DESIGN SPEEDS EQUAL TO OR LESS

THAN 45 MPH, $L = \frac{V^2 W}{60}$